

FCC Test Report

On Model Name : Bluetooth Headset
Model Numbers : S06/S06D
Trade Marks : Original
FCC ID : TEW0509

Prepared for
Guangzhou Wink Communication Technology Co.Ltd

According to FCC Section 15.247
Hopping Frequency Spread Spectrum Device

Test Report #: PSZ-0612-0302-FCC
Prepared by: Ravin Su
Reviewed by: Ivan Wen
QC Manager: Paul Chen

Test Report Released by:

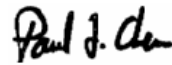

Paul Chen

2007, Feb 09

Date

List of Attached Files

<i>Exhibit Type</i>	<i>File Description</i>	<i>File Name</i>
<i>Test Report</i>	<i>Test Report</i>	<i>TEW0509 _Test report.pdf</i>
<i>Operation Description</i>	<i>Technical Description</i>	<i>TEW0509 _operation description.pdf</i>
<i>BT Modual Specification</i>	<i>BT Modual Specification</i>	<i>TEW0508 _BT Modual Spec.pdf</i>
<i>External Photos</i>	<i>External Photos</i>	<i>TEW0509 External Photos.pdf</i>
<i>Internal Photos</i>	<i>Internal Photos</i>	<i>TEW0509 _Internal Photos.pdf</i>
<i>Block Diagram</i>	<i>Block Diagram</i>	<i>TEW0509 _Block Diagram.pdf</i>
<i>Schematics</i>	<i>Circuit Diagram</i>	<i>TEW0509 _Schematics.pdf</i>
<i>ID Label/Location</i>	<i>Label Artwork and Location</i>	<i>TEW0509 _Label & Location.pdf</i>
<i>User Manual</i>	<i>User Manual</i>	<i>TEW0509 _User Manual.pdf</i>
<i>Test setup photos</i>	<i>Test setup photos</i>	<i>TEW0509_Test Setup Photos.pdf</i>
<i>RF Exposure Letter</i>	<i>RF Exposure Letter</i>	<i>RF Exposure Letter</i>

Test Location

Tests performed at Shenzhen Academy of Metrology and quality Inspection in a Certified ANSI Semi-Anechoic Chamber and Shielded Room.

Test Site Location: Bldg. of Metrology & Quality
Inspection, Longzhu Road, Nanshan
District, Shenzhen, Guangdong, China.

Tel: 86-755-26941617

Fax: 86-755-26941615

FCC Registration Number: 274801

Accreditation Bodies

EMC Compliance Management Group is a fully accredited Test Laboratory for ITE, ISM and Telecommunications Products.



In compliance with the site registration requirements of Section 2.948 of the FCC Rules to perform EMI measurements for the general public.



Accredited by the National Voluntary Laboratory Accreditation Program for the specific scope of accreditation under Lab Code # 200068-0.

Table of Contents

<i>GOVERNMENT DISCLAIMER NOTICE</i>	1
<i>REPRODUCTION CLAUSE</i>	1
<i>ADMINISTRATIVE DATA</i>	2
<i>EUT DESCRIPTION</i>	2
<i>EUT MODEL DIFFERENCES</i>	3
<i>TEST SUMMARY</i>	3
<i>TEST MODE JUSTIFICATION</i>	4
<i>EQUIPMENT MODIFICATION</i>	4
<i>EUT SAMPLE PHOTOS FOR MODEL S06D</i>	5
<i>TEST METHODOLOGY</i>	8
<i>1. FCC 15.207 CONDUCTED EMISSION</i>	9
<i>1. FCC 15.247 (B) (1) MAXIMUM PEAK OUTPUT POWER</i>	12
<i>2. FCC 15.247 (A) (1) HOPPING CHANNEL 20 DB BANDWIDTH</i>	13
<i>3. FCC 15.247 (A) (1) (III) HOPPING CHANNEL CARRIER FREQUENCY SEPARATION</i>	16
<i>4. FCC 15.247 (A) (1) (III) NUMBER OF HOPPING FREQUENCIES</i>	18
<i>5. FCC 15.247 (A) (1) (III) AVERAGE CHANNEL OCCUPANCY TIME</i>	20
<i>6. 100 KHZ BANDWIDTH OF THE BAND EDGES</i>	23
<i>7. RADIATED EMISSION MEASUREMENT</i>	26

Government Disclaimer Notice

When government drawing, specification, or other data are used for any purpose other than in connection with a definitely related government procurement operation, the United States Government thereby incurs no responsibility nor any obligation whatsoever; and the fact that the Government may have formulated, furnished, or in any way supplied the said drawing, specifications, or other data, is not to be regarded by implication or otherwise in any manner licensing the holder or any other person or corporation, or conveying any rights or permission to manufacture, use, or sell patented invention that may in any way be related thereto. This report must not be used to claim product endorsement by NVLAP or any agency of the U.S. Government.

Reproduction Clause

Any reproduction of this document must be done in full. No single part of this document may be reproduced without permission from EMC Compliance Management Group, 670 National Ave., Mountain View, CA 94043.

ADMINISTRATIVE DATA

Test Sample : *Bluetooth Headset*

Model Number : *S06/S06D*

Trade Mark : *Wink*

Serial Number : *Engineering Sample*

Date Tested : *2007, Jan 5st to Jan 20th*

Applicant : *Guangzhou Wink Communication Technology Co., Ltd.
Mengyong Village, Dashi Town
Panyu District, Guangzhou, China*

Telephone : *86-20-34780518*

Fax : *86-20-34785276*

Manufacture : *Guangzhou Wink Communication Technology Co., Ltd.
Mengyong Village, Dashi Town
Panyu District, Guangzhou, China*

EUT Description

Guangzhou Wink Communication Technology Co., Ltd., model S06/S06D (referred to as the EUT in this report) are Battery Operator Hand-portable Bluetooth Headset.

The EUT is a kind of Bluetooth™ technology device, operating in 2.4GHz ISM band, using Frequency Hopping Spread Spectrum(FHSS) Modulation.

The EUT is a stand-alone radio equipment and hand-portable station

The EUT has a DC input port for charger use. The headset doesn't work when charging. In this application, no charger was provided as accessory, so the headset was tested alone.

*Charge Information : Mode I- S004CU50020 Manufacture-Ten pao
Output - DC5V/200mA*

EUT Model Differences

The difference between model S06/S06D is the appearance only, everything else is the same.

Test Summary

The Electromagnetic Compatibility requirements on tested model tested S06D for this test are stated below. All results listed in this report relate exclusively to this above-mentioned model as the Equipment Under Test. This report confers no approval or endorsement upon any other component, host or subsystem used in the test set-up.

The S06D has been found to conform to the following parts of the 47 CFR FCC as detailed below:

Part 15	Requirement	Result Pass/Fail	Comments
15.15(b)	General technical requirements	Pass	The product contains no user accessible controls that increase transmission power above allowable levels.
15.19	Labeling requirement	Pass	The label is shown in the label exhibit.
15.21	Information to user	Pass	Information to the user is shown in the instruction manual exhibit.
15.27	Special accessories	Pass	No special accessories are required for compliance.
15.203	Antenna requirement	Pass	The antenna is soldered to the transmitter board, which is not used accessible, and there is no external antenna connection
15.207	Conducted emission	Pass	The unit complies with the conducted emission limit of 15.207
15.205(a)	Radiated Emissions in Restricted Bands	Pass	The fundamental is not in a Restricted band and the spurious and harmonic emissions in the Restricted bands comply with the general emission limits of 15.209.
15.209(a)	Radiated Emissions limits, general requirements	Pass	The fundamental is not in a Restricted band and the spurious and harmonic emissions in the Restricted bands comply with the general emission limits of 15.209.
15.247 (c)	Out of band & Band Edge measurements	Pass	The unit complies with the band edge emissions limits of 15.247.

Continue on to next page...

15.247(a)(1)	20 dB Bandwidth	Pass	The unit complies with the 20dB bandwidth limits
15.247(b)	Maximum peak Output Power	Pass	The unit complies with the peak power limits of 15.247.
15.247(a)(1)	Hopping Channel Carrier Frequency Separation (>25 KHz)	Pass	The unit complies with Hopping Frequency Separation the limits of 15.247.
15.247(a)(1)(iii)	Number of the Hopping Frequency (channels)	Pass	The unit complies with the Number of the Hopping Frequency limits of 15.247.
15.247(a)(1)(ii)	Average Channel Occupancy Time (<0.4s)	Pass	The unit complies with Average Channel Occupancy Time (<0.4s) limits of 15.247.
15.247(e)	RF exposure	Pass	The unit complies with the limits of 1.1307.

This report an application for Certification of Transmitter operation pursuant to FCC part 15.247, code of federal regulations 47. The product covered by this report is the S06D. This report is designed to demonstrate the compliance of this device with the requirements outlined in 47 CFR Part 15 using the methods in CFR 47 Part 2.

Test Mode Justification

This device complies with Part 15 of the FCC rules. Operations is subject to the following two conditions: (1) This device may not cause harmful interference, and (2) This device must accept any interference received, including interference that may cause undesired operation.

Equipment Modification

Any modifications installed previous to testing by Guangzhou Wink Communication Technology Co., Ltd.. will be incorporated in each production model sold or leased.

There were no modifications installed by EMC Compliance Management Group (China) test personnel.

EUT Sample Photos for Model S06D

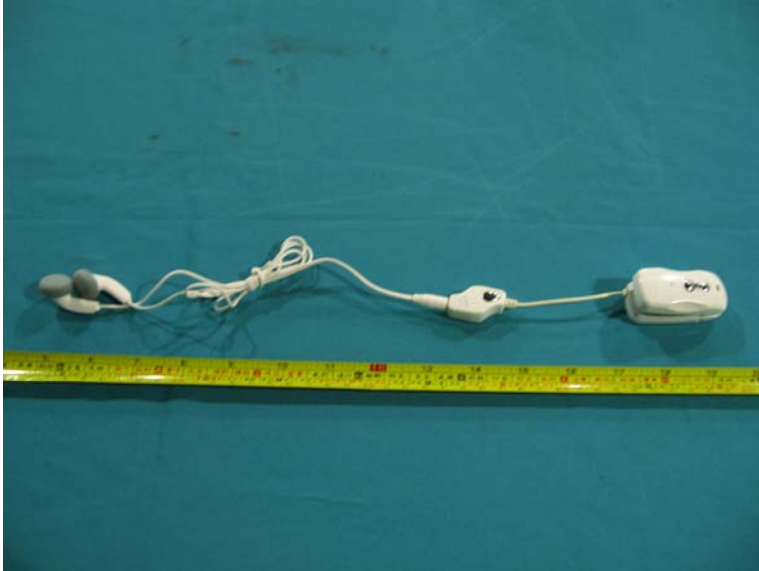

EUT View



Front View



Back View

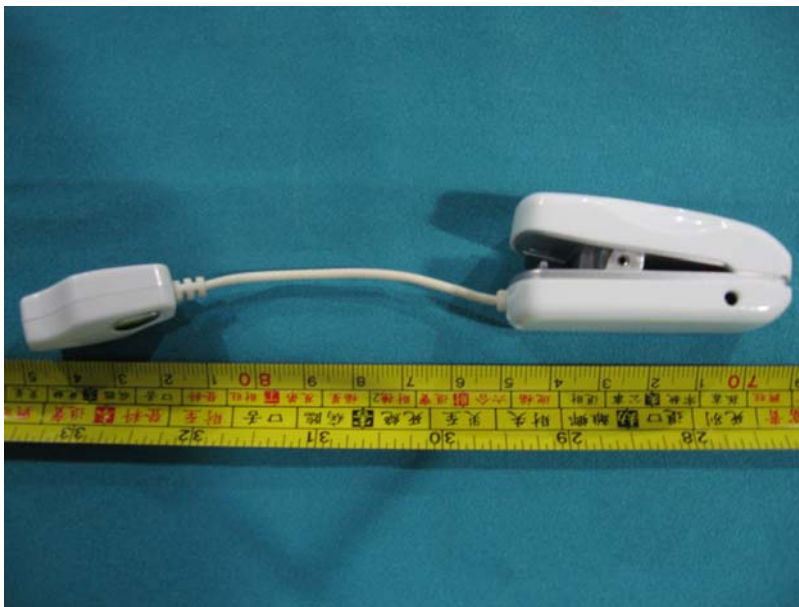

Side View

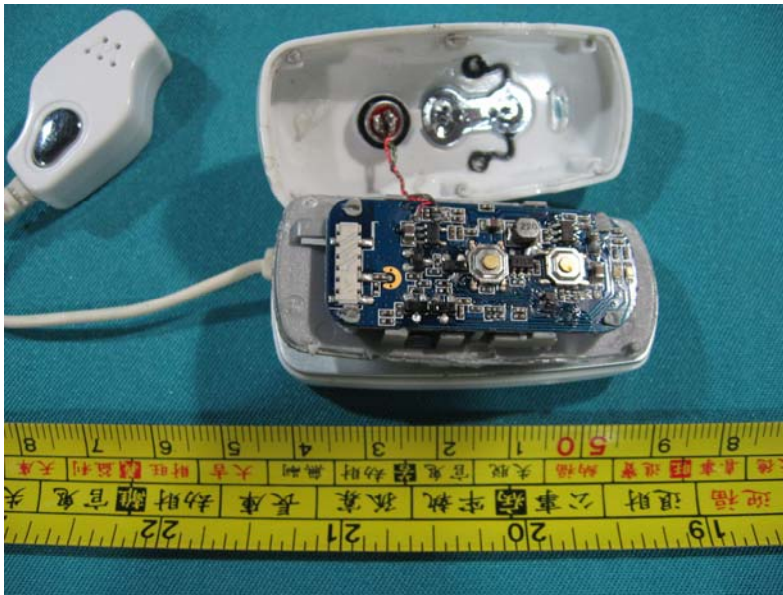

Inside View #1



Inside View #2

Test Methodology

Testing was performed according to the measurement guidelines specified in FCC Public Notice DA00-705.

Radiated emissions testing are performed according to the procedures specified in ANSI C63.4-2003.

Frequency Range investigated: 30 MHz to 25 GHz

Measurement Distance: 3 meter

EUT Power Source: Battery

*Emission Maximization: Antenna (1m to 4m) height and Horizontal/Vertical polarization
360-degree turntable rotated
and EUT rotated three orthogonal axes.*

Temperature: 25°C

Humidity: 45%

Air Pressure: 1010 hpa

1. FCC 15.207 Conducted emission

Conducted limits:

According to FCC §15.207, the radio frequency voltage that is conducted back onto the AC power line on any frequency within the band 150 kHz to 30 MHz shall not exceed the limits in the following table, as measured using a 50H/50 ohms line impedance stabilization network (LISN).

Frequency of Emission (MHz)	Conducted Limit (dBuV)	
	Quasi-peak	Average
0.15-0.5	66 to 56*	56 to 46*
0.5-5	56	46
5-30	60	50

Test procedure :

According to description of ANSI C63.4-2003 sec.13.1.3 , the AC power line conducted emission measurements were carried out. The conducted measurements were performed using the EMI test receiver to observe the emission characteristics of the EUT.

The EUT configuration , cable configuration and mode of operation were determined for producing the maximum level of emission , These configurations were used for final AC power line conducted emissions measurements .

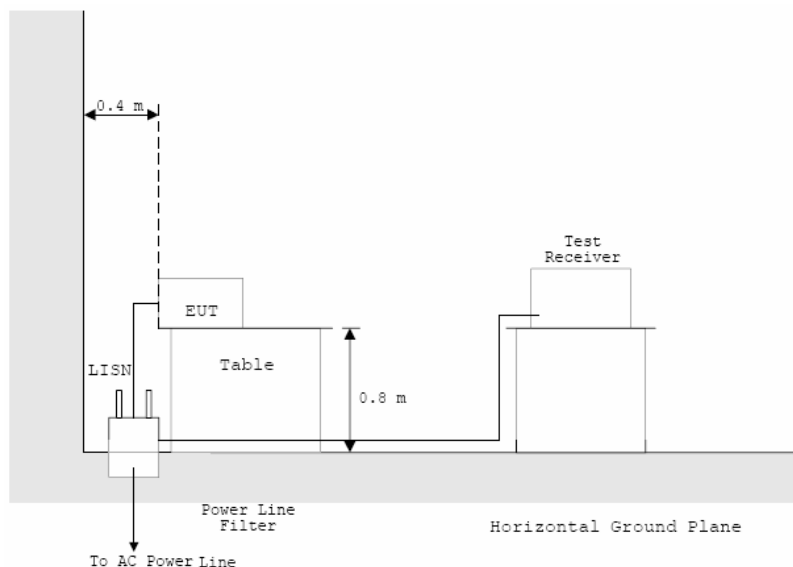

Test result :

Phase	Freq. (MHz)	Limit Value (dB μ V)		Emission Level (dB μ V)	
		QP	AV	QP	AV
L	0.198	63.6	53.6	45.4	29.3
L	0.720	56	46	32.6	17.6
L	1.170	56	46	29.1	15.3
N	0.190	64	54	43.9	23.0
N	0.330	59.4	49.4	35.3	19.0
N	0.638	56	46	33.6	14.5

NOTE:

1. QP and AV are abbreviations of the quasi-peak and average individually.
2. The emission levels recorded above is the larger ones of both L phase and N phase.

Test Equipment List:

Test Equipment	Manufacturer/ Model	Serial No.	Last Cal.	Cal. Due
EMI Test Receiver	Rohde & Schwarz/ ESCS30	SB3319	01/25/2007	01/25/2008
AMN	Rohde & Schwarz/ ESH3-Z5	SB3996	01/25/2007	01/25/2008

Note: All testing were performed using internationally recognized standards. All test instruments were calibrated and traceable to the National Institute of Standards and Technology (NIST).

Plot of Conducted Emission Measurement :

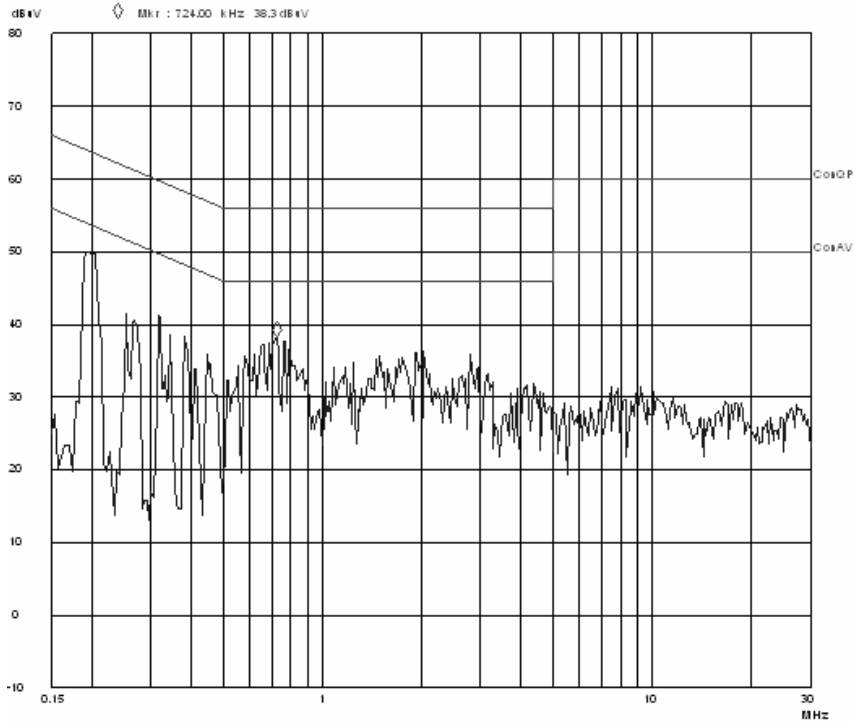

L phase

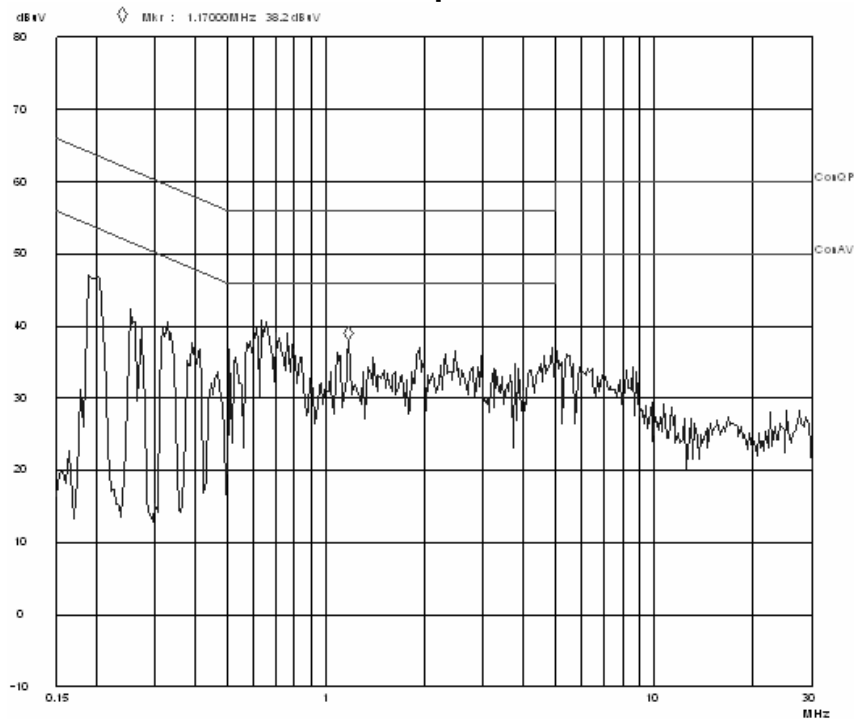

N phase

1. FCC 15.247 (b) (1) Maximum Peak Output Power

Peak Output Power Limit:

For frequency systems operating in the 2400-2483.5MHz band employing at least 75 hopping channels, and all frequency hopping systems in the 5725-5850MHz band: 1Watt. For all other frequency hopping systems in the 2400-2483.5MHz band : 0.125Watts.

Test Procedure:

1. Place the EUT on the table and set it in transmitting mode .
2. Remove the antenna from the EUT and then connect the transmitter output to the power meter via a suitable attenuator.
3. Record the max. reading
4. repeat above procedures until all frequency measured were complete.

Test Data:

Channel	Frequency (MHz)	Reading (dBm)	Attenuator (dB)	Corrected Reading (dBm)	Limit	Result
Low	2402	-31.6	30.0	-1.6	1W (30dBm)	Pass
Middle	2441	-31.8	30.0	-1.8	1W (30dBm)	Pass
High	2480	-32.5	30.0	-2.5	1W (30dBm)	Pass

Note: 1W= 10log1000=30dBm

Test Equipment List:

Test Equipment	Manufacturer	Model	Serial No.	Last Cal.	Cal. Due
Power Meter	HP	436A	SB4842	25/01/06	25/01/07
Power Sensor	HP	8484A	N/A	N/A	N/A
Attenuator	MFR	M3933/10-5	N/A	N/A	N/A

2. FCC 15.247 (a) (1) Hopping Channel 20 dB Bandwidth

Test Procedure:

1. Place the EUT on the table and set it in transmitting mode .
2. Remove the antenna from the EUT and then connect a low loss RF cable from the antenna port to to the test receiver
3. Set the test receiver as RBW=300KHz VBW=1MHz
4. Mark the peak frequency and -20dB (upper and lower) frequency
5. Repeat above procedures until all frequency measured were complete

Test Results:

Channel	Frequency (MHz)	20 dB Bandwidth
Low	2402	1.27 MHz
Mid	2441	1.29 MHz
High	2480	1.29MHz

Test Equipment List:

Test Equipment	Manufacturer	Model	Serial No.	Last Cal.	Cal. Due
EMI Test Receiver	Rohde & Schwarz	ES126	SB3436	25/01/06	25/01/07
Cable	Huber+Suhner	SUCOFLEX 104PEA	N/A	N/A	N/A
Attenuator	MFR	M3933/10-5	N/A	N/A	N/A

Plots of 20dB Bandwidth :

Low Channel:

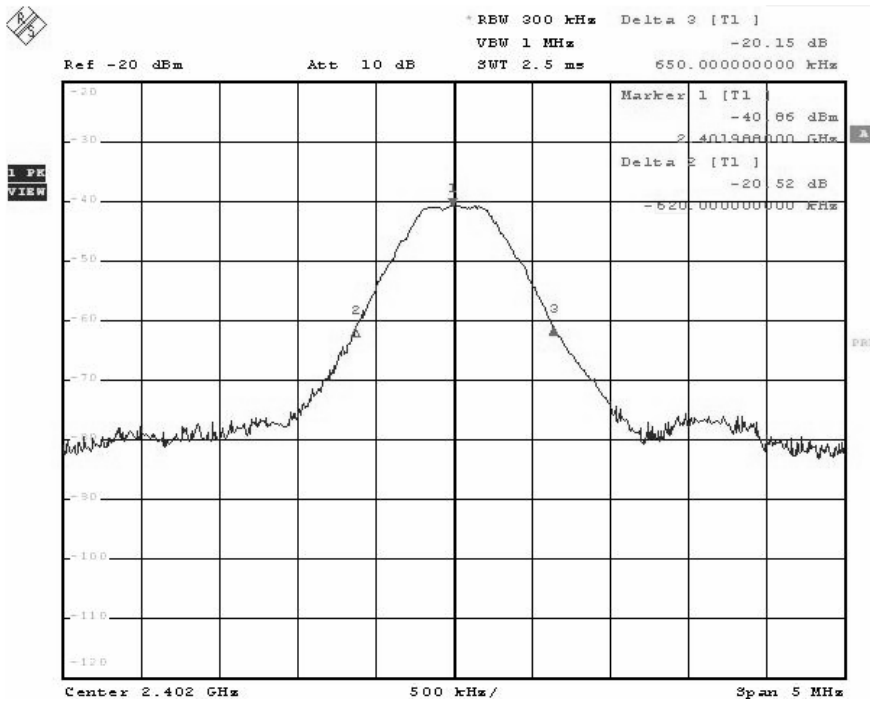

Mid Channel:

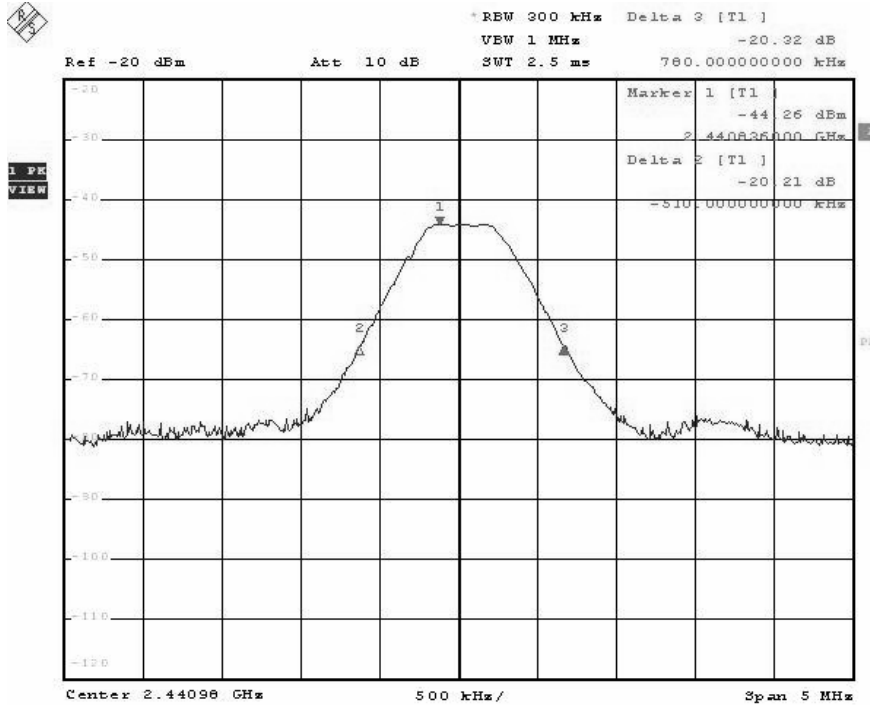

High Channel:

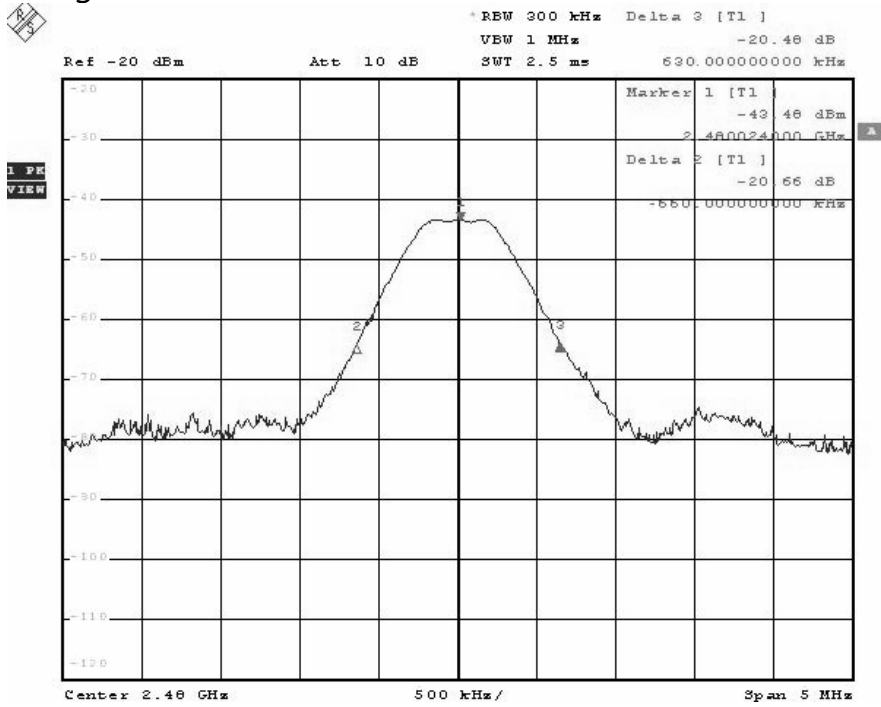

3. FCC 15.247 (a) (1) (iii) Hopping Channel Carrier Frequency Separation

Carrier Frequency Separation Limit:

According to 15.247(a)(1), frequency hopping systems operating in the 2400 - 2483.5 MHz band may have hopping channel carrier frequencies that are separated by 25 KHz or 2/3 of the 20dB bandwidth, whichever is greater, provided the systems operate with an output power no greater than 125mW (21 dBm).

Test Procedures:

1. Enable the hopping function for the EUT.
2. Set analyzer's span wide enough to capture the peaks of two adjacent channels.
3. Set RBW > 1% of the span, VBW = RBW, Max peak hold.
4. Using the Delta Marker function to determine the separation between the peaks of the adjacent channels.

Test Results:

Channel	Hopping Frequency Separation (MHz)	2/3 20 dB Bandwidth (MHz)	Result
Mid.	1.008	0.86	Pass

Note: The EUT's output power is 1.3 dBm.

Test Equipment List:

Test Equipment	Manufacturer	Model	Serial No.	Last Cal.	Cal. Due
EMI Test Receiver	Rohde & Schwarz	ES126	SB3436	25/01/06	25/01/07
Cable	Huber+Suhner	SUCOFLEX 104PEA	N/A	N/A	N/A
Attenuator	MFR	M3933/10-5	N/A	N/A	N/A

Plots of Channel Separation:

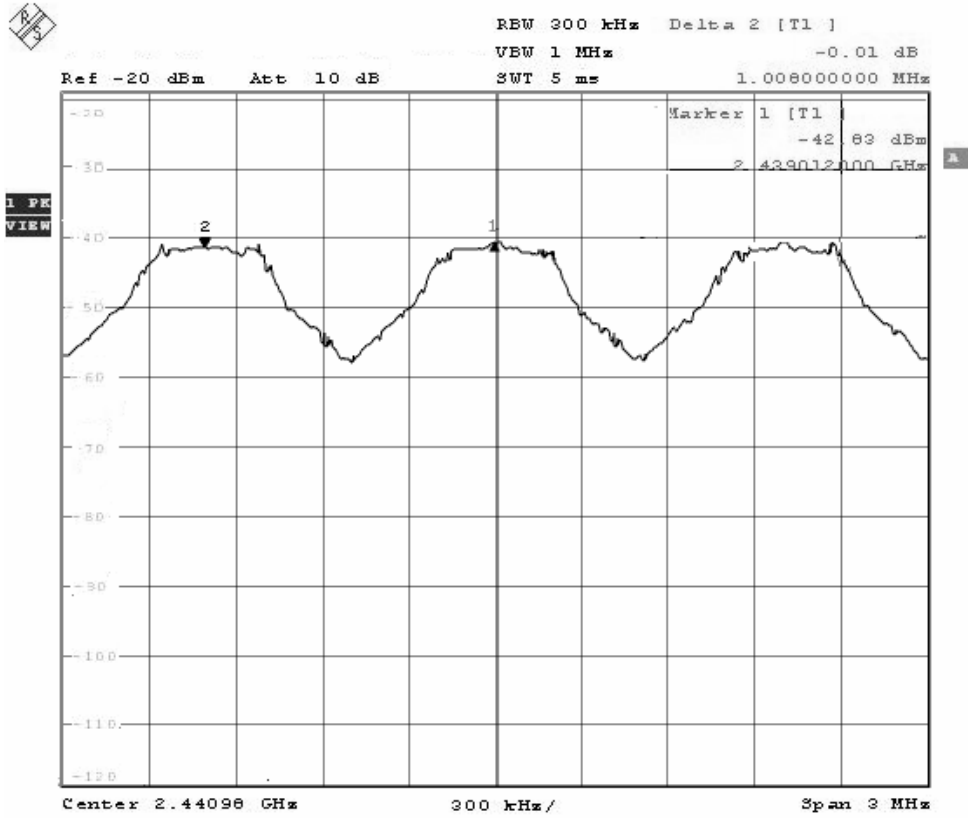

4. FCC 15.247 (a) (1) (iii) Number of Hopping Frequencies

Limit for Number of Hopping Frequencies:

According 15.247(a)(1)(iii), frequency hopping systems in 2400 - 2483.5 MHz shall use at least 15 channels.

Test Procedures:

1. Enable hopping function for the EUT.
2. Set the analyzer's span = the half band of operation (2400 - 2441 MHz)
3. Set RBW > 1% of the span, VBW = RBW, Max. peak hold.
4. Repeat the above for the 2nd half band (2441 - 2483.5 MHz)

Test Data:

<i>Frequency (MHz)</i>	<i>Number of hopping channels</i>	<i>Result</i>
2402 -2480	79	pass

Test Equipment List:

<i>Test Equipment</i>	<i>Manufacturer</i>	<i>Model</i>	<i>Serial No.</i>	<i>Last Cal.</i>	<i>Cal. Due</i>
EMI Test Receiver	Rohde & Schwarz	ES126	SB3436	25/01/06	25/01/07
Cable	Huber+Suhner	SUCOFLEX 104PEA	N/A	N/A	N/A
Attenuator	MFR	M3933/10-5	N/A	N/A	N/A

Plots of Number of Hopping Frequencies:

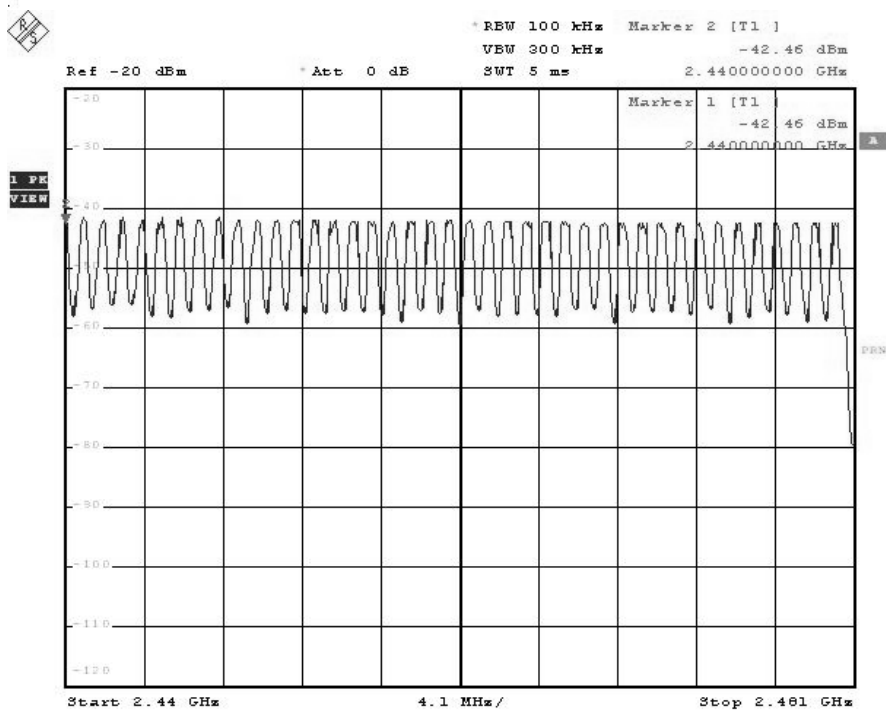
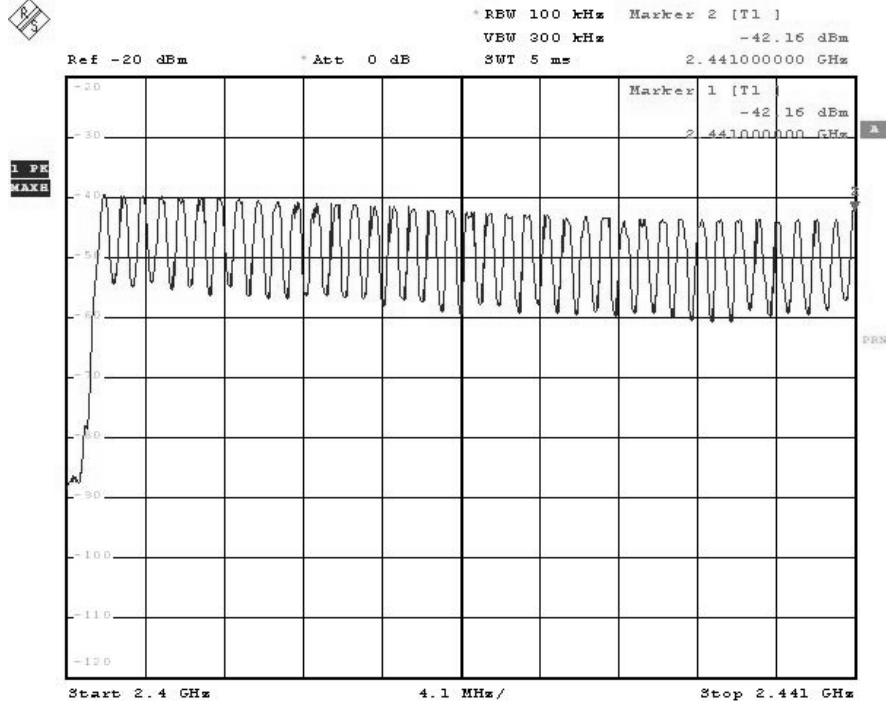

5. FCC 15.247 (a) (1) (iii) Average Channel Occupancy Time

Limit of Average Channel Occupancy Time:

According to 15.247(a)(1)(iii), for frequency hopping systems in the 2400 - 2483.5 MHz band, the average time of occupancy on any channel shall not be greater than 0.4 S within a period of 0.4 S multiplied by the number of hopping channels employed.

Test Procedures:

1. Check the calibration of the measuring instrument using either an internal calibrator or a known signal from an external generator.
2. Position the EUT without connection to measurement instrument. Turn on the EUT and connect it to measurement instrument. The EUT must have its hopping function enabled.
3. Use the following settings:
Span = zero span, centered on a hopping channel
RBW = 1 MHz
VBW \geq RBW
Sweep = as necessary to capture the entire dwell time per hopping channel
Detector function = peak
Trace = max hold
4. Use the marker-delta function to determine the dwell time. Plot the result on the screen of spectrum analyzer.
5. Repeat above procedures until all frequencies measured were complete.

Test Result : PASS

Test Data:

Period=0.4 sec x 79 channel= 31.6 sec

DH1 Mode:

The Bluetooth system hops at a rate of 1600 times per second. This means there are 1600 timeslots in one second. The DH1 data rate operates on a one-slot transmission and one-slotreceiving basis. Thus there are $1600/(1+1) = 800$ transmissions per second. In one period for each particular channel there are $800 \times 31.6 / 79 = 320$ times of transmissions.

CH Mid(2441MHz) : the dwell time is $0.408ms \times 320 = 130.56ms$

The maximum time of occupancy for a particular channel is 130.56ms in any 31.6 second period,which is less than the 400ms allowed by therules; therefore, it meets the requirements of this section.

Note:

- 1. Please see the Plotted Data as follows*
- 2. The expanded uncertainty of dwell time on each channel tests is 2dB.*

Test Equipment List:

Test Equipment	Manufacturer	Model	Serial No.	Last Cal.	Cal. Due
<i>EMI Test Receiver</i>	<i>Rohde & Schwarz</i>	<i>ES126</i>	<i>SB3436</i>	<i>25/01/06</i>	<i>25/01/07</i>
<i>Cable</i>	<i>Huber+Suhner</i>	<i>SUCOFLEX 104PEA</i>	<i>N/A</i>	<i>N/A</i>	<i>N/A</i>
<i>Attenuator</i>	<i>MFR</i>	<i>M3933/10-5</i>	<i>N/A</i>	<i>N/A</i>	<i>N/A</i>

Plotted Data for Channel Dwell Time:

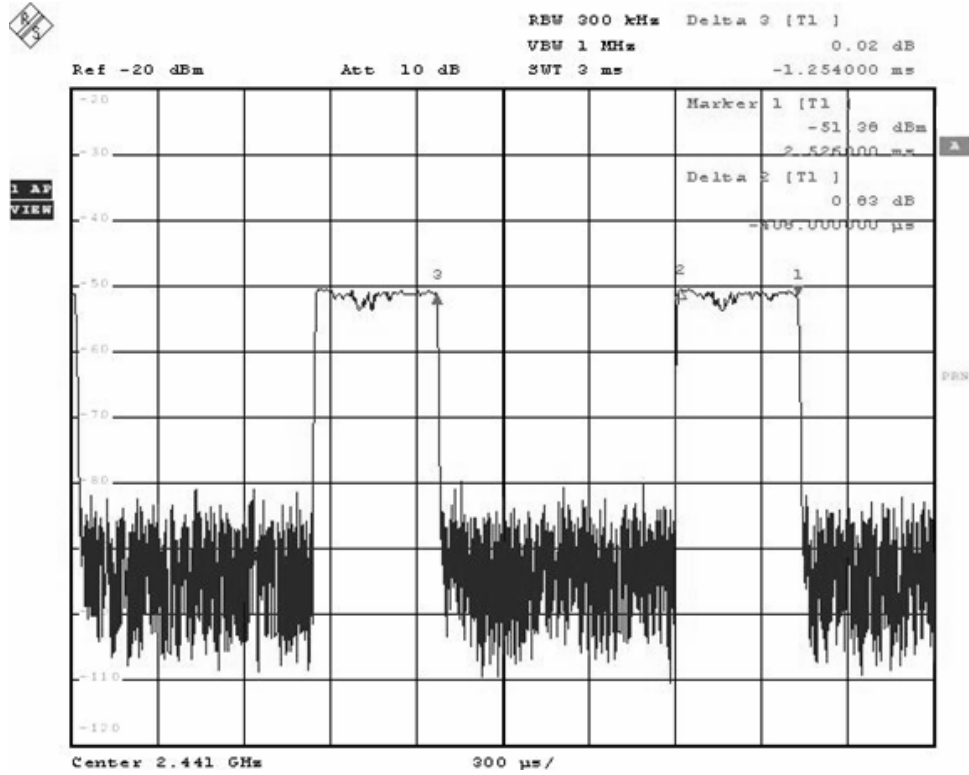

6. 100 kHz bandwidth of the band edges

Limit:

According to 15.247(c), in any 100 kHz bandwidth outside the frequency band in which the spread spectrum or digitally modulated intentional radiator is operating, the radio frequency power that is produced by the intentional radiator shall be at least 20 dB below that in the 100 kHz bandwidth within the band that contains the highest level of the desired power, based on either an RF conducted or a radiated measurement. Attenuation below the general limits specified in Section 15.209(a) is not required.

Test Procedures:

1. Check the calibration of the measuring instrument using either an internal calibrator or a known signal from an external generator.
2. Position the EUT without connection to measurement instrument. Turn on the EUT and connect its antenna terminal to measurement instrument via a low loss cable. Then set it to any one measured frequency within its operating range and make sure the instrument is operated in its linear range.
3. Use the following settings:
Span = wide enough to capture the peak level of the in-band emission and all spurious emissions (e.g., harmonics) from the lowest frequency generated in the EUT up through the 10th harmonic. Typically, several plots are required to cover this entire span.
RBW = 100 kHz
VBW = 300 kHz
Sweep = Auto
Detector function = peak
Trace = max hold.
4. Allow the trace to stabilize. Set the marker on the peak of any spurious emission recorded. Plot the result on the screen of spectrum analyzer.
5. Repeat above procedures until all measured frequencies were complete.

Test Result : PASS

Test Equipment List:

Test Equipment	Manufacturer	Model	Serial No.	Last Cal.	Cal. Due
EMI Test Receiver	Rohde & Schwarz	ES126	SB3436	25/01/06	25/01/07
Cable	Huber+Suhner	SUCOFLEX 104PEA	N/A	N/A	N/A
Attenuator	MFR	M3933/10-5	N/A	N/A	N/A

Plot of Band Edges Test :

Low Channel:

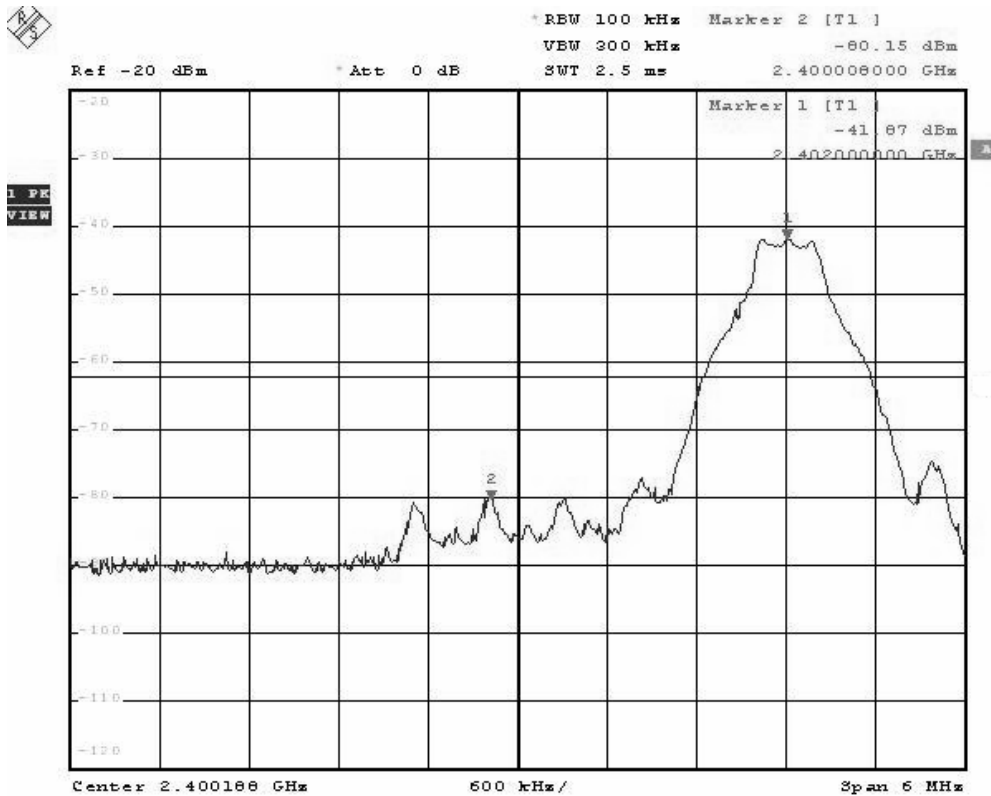



*RBW 100 kHz
 *VBW 300 kHz
 SWT 10 ms

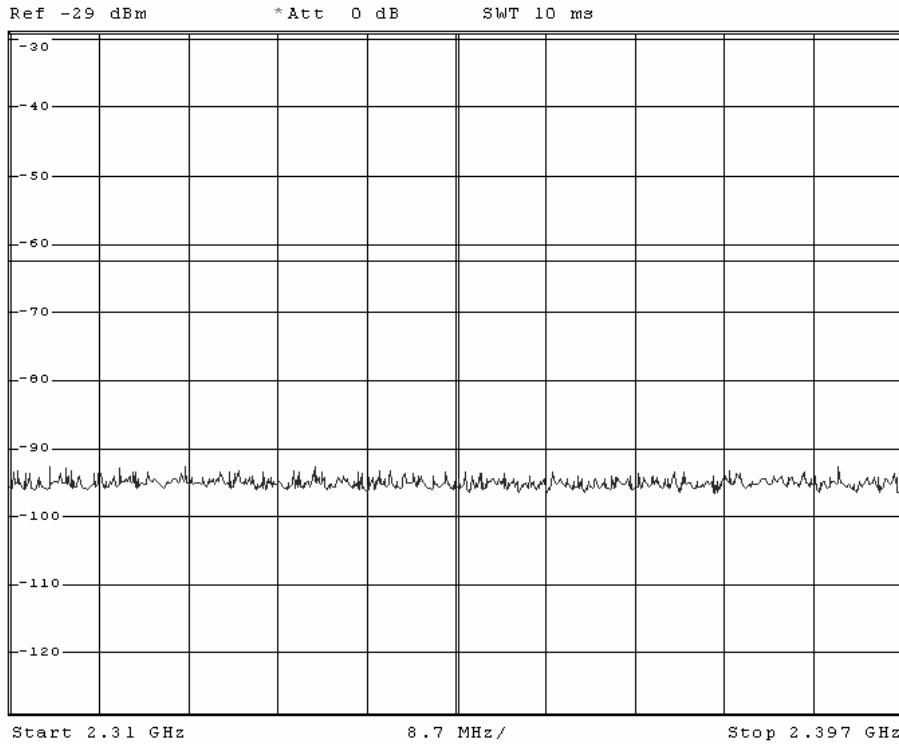

High Channel :



*RBW 100 kHz Delta 2 [T1]
 *VBW 300 kHz -65.67 dB
 SWT 2.5 ms 13.950000000 MHz

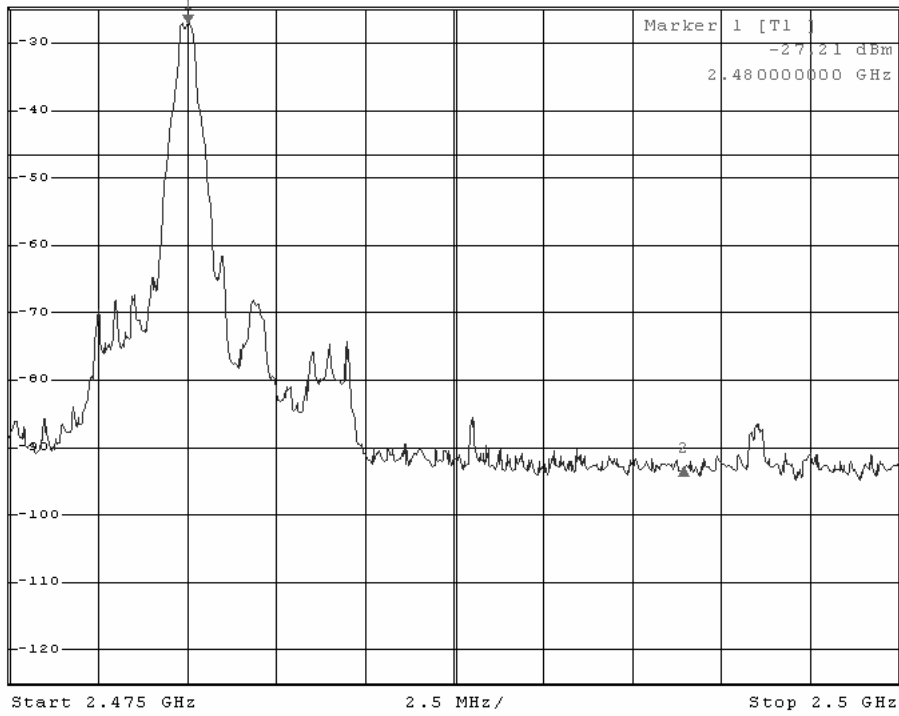

7. Radiated Emission Measurement

Limit:

According to §15.247 (a), operation under this provision is limited to frequency hopping and direct sequence spread spectrum, and the out band emission shall be comply with §15.247 (c)

.And according to 15.33(a)(1),for an intentional radiator operates below 10GHz,the frequency range of measurements to the tenth harmonic of the highest fundamental frequency or to 40GHz,whichever is lower.

Radiated emissions, which fall in the restricted band, as defined in Section 15.205(a), must comply with the radiated emission limits specified in §15.209(a)

Frequency (MHz)	Field strength (micro volts/meter)	Measure distance (meters)
0.009-0.490	2400 /F (KHz)	300
0.490-1.705	24000 /F (KHz)	30
1.705-30.0	30	30
30-88	100	3
88-216	150	3
216-960	200	3
Above 960	500	3

Test Procedures:

1. *Setup the configuration per figure 1 and 2 for frequencies measured below and above 1 GHz respectively.*
2. *For emission frequencies measured below 1 GHz, a pre-scan is performed in a shielded chamber to determine the accurate frequencies of higher emissions will be checked on a open test site. As the same purpose, for emission frequencies measured above 1 GHz, a pre-scan also be performed with a 3 meter measuring distance before final test.*
3. *For emission frequencies measured below and above 1 GHz, set the spectrum analyzer on a 100 kHz and 1 MHz resolution bandwidth respectively for each frequency measured in step 2.*
4. *The search antenna is to be raised and lowered over a range from 1 to 4 meters in horizontally polarized orientation. Position the highness when the highest value is indicated on spectrum analyzer, then change the orientation of EUT on test table over a range from 0 degree to 360 degree With a speed as slow as possible, and keep the azimuth that highest emission is indicated on the spectrum analyzer. Vary the antenna position again and record the highest value as a final reading. A RF test receiver is also used to confirm emissions measured.*
5. *Repeat step 4 until all frequencies need to be measured were complete.*
6. *Repeat step 5 with search antenna in vertical polarized orientations.*
7. *Check the three frequencies of highest emission with varying the placement of cables associated with EUT to obtain the worse case and record the result.*

Test Result : PASS

Set-up/Configuration:

Figure 1 : Frequencies measured below 1 GHz configuration

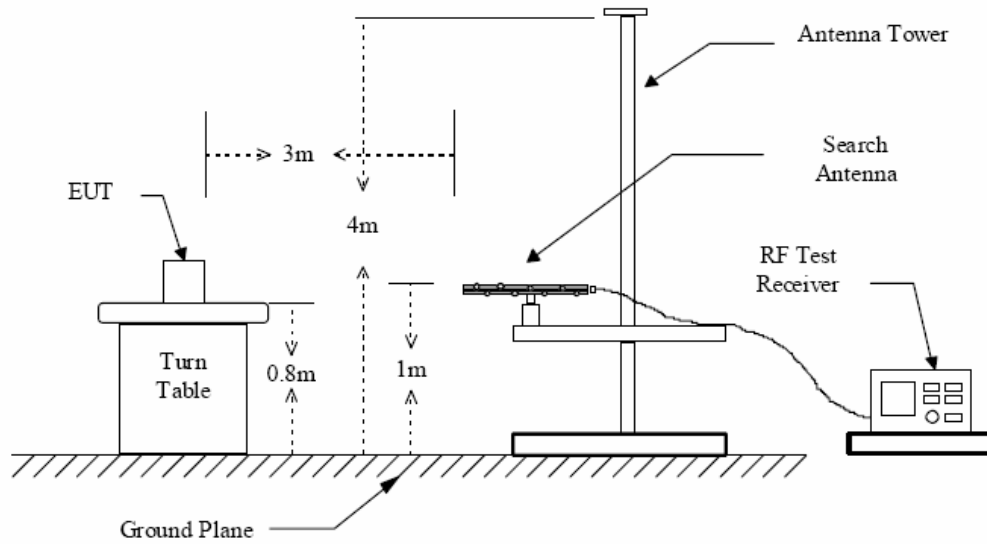
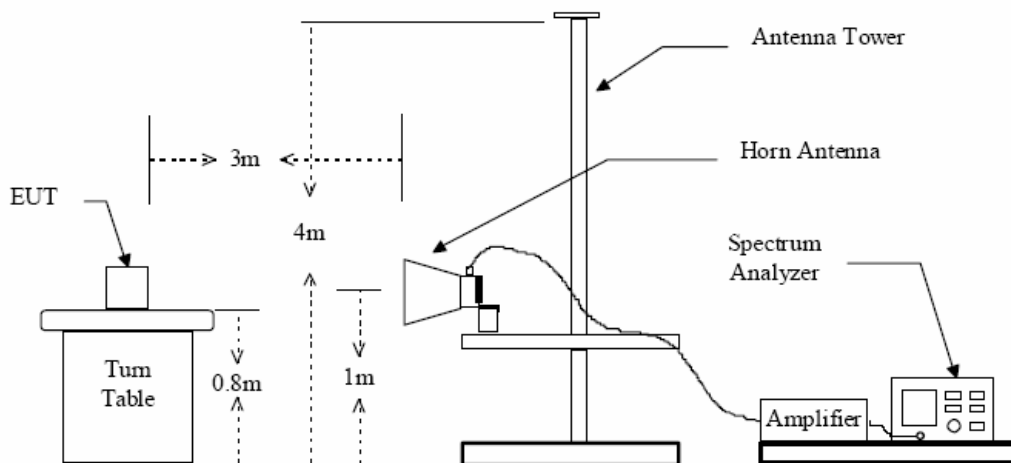

Figure 2 : Frequencies measured above 1 GHz configuration



Test Equipment List:

<i>Test Equipment</i>	<i>Manufacturer</i>	<i>Model</i>	<i>Serial No.</i>	<i>Last Cal.</i>	<i>Cal. Due</i>
<i>EMI Test Receiver</i>	<i>Rohde & Schwarz</i>	<i>ES126</i>	<i>SB3436</i>	<i>25/01/06</i>	<i>25/01/07</i>
<i>Bilog Antenna</i>	<i>Chase</i>	<i>CBL6112B</i>	<i>SB3440</i>	<i>25/01/06</i>	<i>25/01/07</i>
<i>Horn Antenna</i>	<i>Rohde & Schwarz</i>	<i>HF906</i>	<i>SB3434</i>	<i>25/01/06</i>	<i>25/01/07</i>
<i>Horn Antenna</i>	<i>Rohde & Schwarz</i>	<i>HF906</i>	<i>SB3435</i>	<i>25/01/06</i>	<i>25/01/07</i>
<i>Antenna</i>	<i>Schwarzbeck</i>	<i>VUBA9117</i>	<i>SB3174</i>	<i>25/01/06</i>	<i>25/01/07</i>
<i>Signal Generator</i>	<i>Rohde & Schwarz</i>	<i>SMR20</i>	<i>SB3438</i>	<i>25/01/06</i>	<i>25/01/07</i>
<i>Cable</i>	<i>Huber+Suhner</i>	<i>SUCOFLEX 104PEA</i>	<i>N/A</i>	<i>N/A</i>	<i>N/A</i>
<i>Attenuator</i>	<i>MFR</i>	<i>M3933/10-5</i>	<i>N/A</i>	<i>N/A</i>	<i>N/A</i>

Instrument Setup:

<i>Frequency</i>	<i>Resolution bandwidth</i>	<i>Video bandwidth</i>	<i>Function</i>
<i>< 1 GHz</i>	<i>120 KHz</i>	<i>300 KHz</i>	<i>QP</i>
<i>> 1 GHz</i>	<i>1 MHZ</i>	<i>3 MHZ</i>	<i>Peak</i>
<i>> 1 GHz</i>	<i>1 MHZ</i>	<i>10 Hz</i>	<i>Ave.</i>

Radiated Spurious Emission Data(Above 1GHz) :

Low Channel (2402MHz)

Frequency GHz	Emission (dBuV/m)		Read Value (dBuV)		Correction Factor (dB/m)	Polarization	Limits (dBuV/m)		Note
	AV	PK	AV	PK			AV	PK	
1.600	40.26	48.60	35.26	43.60	-5.0	Horizontal	54.0	74.0	Spurious
1.600	38.13	42.40	33.13	37.40	-5.0	Vertical	54.0	74.0	Spurious
2.402	42.31	85.86	38.31	81.86	-4.0	Horizontal			Fundamental
2.402	41.08	90.84	37.08	86.84	-4.0	Vertical			Fundamental
4.804	38.54	50.92	36.54	48.92	-2.0	Horizontal	54.0	74.0	Harmonic
4.804	38.13	50.48	36.13	48.48	-2.0	Vertical	54.0	74.0	Harmonic
7.206	32.52	42.63	31.52	41.63	-1.0	Horizontal	54.0	74.0	Harmonic
7.206	32.43	41.86	31.43	40.86	-1.0	Vertical	54.0	74.0	Harmonic

Mid Channel (2441MHz)

Frequency GHz	Emission (dBuV/m)		Read Value (dBuV)		Correction Factor (dB/m)	Polarization	Limits (dBuV/m)		Note
	AV	PK	AV	PK			AV	PK	
1.621	39.84	45.80	34.84	40.80	-5.0	Horizontal	54.0	74.0	Spurious
1.621	38.08	43.40	33.08	38.40	-5.0	Vertical	54.0	74.0	Spurious
2.441	41.66	83.62	37.66	79.62	-4.0	Horizontal			Fundamental
2.441	40.41	85.56	36.41	81.56	-4.0	Vertical			Fundamental
4.882	36.65	48.28	34.65	46.28	-2.0	Horizontal	54.0	74.0	Harmonic
4.882	36.40	47.48	34.40	45.48	-2.0	Vertical	54.0	74.0	Harmonic
7.323	31.61	40.04	30.61	39.04	-1.0	Horizontal	54.0	74.0	Harmonic
7.323	31.48	41.35	30.48	40.35	-1.0	Vertical	54.0	74.0	Harmonic

High Channel (2480M)

Frequency GHz	Emission (dBuV/m)		Read Value (dBuV)		Correction Factor (dB/m)	Polarization	Limits (dBuV/m)		Note
	AV	PK	AV	PK			AV	PK	
1.653	39.65	44.70	34.65	39.7	-5.0	Horizontal	54.0	74.0	Spurious
1.653	40.36	47.30	35.36	42.30	-5.0	Vertical	54.0	74.0	Spurious
2.480	39.20	77.82	35.20	73.82	-4.0	Horizontal			Fundamental
2.480	38.97	83.60	34.97	79.60	-4.0	Vertical			Fundamental
4.960	35.42	47.82	33.42	45.82	-2.0	Horizontal	54.0	74.0	Harmonic
4.960	35.10	47.18	33.10	45.18	-2.0	Vertical	54.0	74.0	Harmonic
7.440	30.40	41.93	29.40	40.40	-1.0	Horizontal	54.0	74.0	Harmonic
7.440	30.32	41.62	29.32	40.62	-1.0	Vertical	54.0	74.0	Harmonic

Restricted Frequency band : 2310MHz-2390MHz

Frequency GHz	Emission (dBuV/m)		Read Value (dBuV)		Correction Factor (dB/m)	Polarization	Limits (dBuV/m)		Note
	AV	PK	AV	PK			AV	PK	
2.321	36.42	60.20	32.42	56.20	-4.0	Horizontal	54.0	74.0	Spurious
2.321	35.18	56.20	31.18	52.20	-4.0	Vertical	54.0	74.0	Spurious
2.377	35.64	58.10	31.64	54.10	-4.0	Horizontal	54.0	74.0	Fundamental
2.377	35.36	57.10	31.36	53.10	-4.0	Vertical	54.0	74.0	Fundamental

Restricted Frequency band : 2483.5MHz-2500MHz

Frequency GHz	Emission (dBuV/m)		Read Value (dBuV)		Correction Factor (dB/m)	Polarization	Limits (dBuV/m)		Note
	AV	PK	AV	PK			AV	PK	
2.488	36.28	59.20	32.28	55.20	-4.0	Horizontal	54.0	74.0	Spurious
2.488	35.62	58.10	31.62	54.10	-4.0	Vertical	54.0	74.0	Spurious
2.493	35.84	59.10	31.84	55.10	-4.0	Horizontal	54.0	74.0	Fundamental
2.493	35.59	58.00	31.59	54.00	-4.0	Vertical	54.0	74.0	Fundamental

Note :

1. Emission level(dBuV/m)=Read Value(dBuV) + Correction Factor(dB/m)
2. Correction Factor(dB/m) = Antenna Factor (dB/m) + Cable Factor (dB)
3. The other emission levels were very low against the limit(>20dB to limit).
4. Remark "--" means that the emissions level is too low to be measured.

Radiated Spurious Emission Data below 1G (worst case):

Frequency MHz	Emission (dBuV/m)	Read Value (dBuV)	Correction Factor (dB/m)	Polarization	Limits (dBuV/m)
	QP	QP			QP
145.56	33.0	22.6	-10.4	Vertical	43.5
216.57	33.6	27.6	-6.0	Vertical	46.0
264.09	32.0	28.2	-3.8	Vertical	46.0
431.60	31.5	26.0	-5.5	Horizontal	46.0
521.90	29.7	24.8	-4.9	Horizontal	46.0
566.70	31.7	26.4	-5.3	Horizontal	46.0