



A D T

RF TEST REPORT

REPORT NO.: RF120302C25-1

MODEL NO.: TL-WDN4800

FCC ID: TE7WDN4800

IC: 8853A-WDN4800

RECEIVED: Mar. 02, 2012

TESTED: Mar. 10 to 29, 2012

ISSUED: Apr. 13, 2012

APPLICANT: TP-LINK TECHNOLOGIES CO., LTD.

ADDRESS: Building 24 (floors 1,3,4,5) and 28
(floors1-4) Central Science and Technology
Park,Shennan Rd, Nanshan,
Shenzhen,China

ISSUED BY: Bureau Veritas Consumer Products Services
(H.K.) Ltd., Taoyuan Branch Hsin Chu Laboratory

LAB ADDRESS : No. 81-1, Lu Liao Keng, 9th Ling, Wu Lung Tsuen,
Chiung Lin Hsiang, Hsin Chu Hsien 307, Taiwan,
R.O.C.

TEST LOCATION (1): No. 81-1, Lu Liao Keng, 9th Ling, Wu Lung Tsuen,
Chiung Lin Hsiang, Hsin Chu Hsien 307, Taiwan,
R.O.C.

TEST LOCATION (2): No. 49, Ln. 206, Wende Rd., Shangshan Tsuen,
Chiung Lin Hsiang, Hsin Chu Hsien 307, Taiwan,
R.O.C.

This test report consists of 62 pages in total. It may be duplicated completely for legal use with the approval of the applicant. It should not be reproduced except in full, without the written approval of our laboratory. The client should not use it to claim product certification, approval, or endorsement by TAF or any government agencies. The test results in the report only apply to the tested sample.





A D T

Table of Contents

RELEASE CONTROL RECORD	4
1. CERTIFICATION	5
2. SUMMARY OF TEST RESULTS	6
2.1 MEASUREMENT UNCERTAINTY	7
3. GENERAL INFORMATION	8
3.1 GENERAL DESCRIPTION OF EUT	8
3.2 DESCRIPTION OF TEST MODES	11
3.2.1 TEST MODE APPLICABILITY AND TESTED CHANNEL DETAIL	12
3.3 GENERAL DESCRIPTION OF APPLIED STANDARDS	14
3.4 DUTY CYCLE OF TEST SIGNAL	14
3.5 DESCRIPTION OF SUPPORT UNITS	15
3.6 CONFIGURATION OF SYSTEM UNDER TEST	16
4. TEST TYPES AND RESULTS	18
4.1 CONDUCTED EMISSION MEASUREMENT	18
4.1.1 LIMITS OF CONDUCTED EMISSION MEASUREMENT	18
4.1.2 TEST INSTRUMENTS	18
4.1.3 TEST PROCEDURES	19
4.1.4 DEVIATION FROM TEST STANDARD	19
4.1.5 TEST SETUP	20
4.1.6 EUT OPERATING CONDITIONS	20
4.1.7 TEST RESULTS	21
4.2 RADIATED EMISSION MEASUREMENT	23
4.2.1 LIMITS OF RADIATED EMISSION MEASUREMENT	23
4.2.2 LIMITS OF UNWANTED EMISSION OUT OF THE RESTRICTED BANDS	24
4.2.3 TEST INSTRUMENTS	25
4.2.4 TEST PROCEDURES	26
4.2.5 DEVIATION FROM TEST STANDARD	26
4.2.6 TEST SETUP	27
4.2.7 EUT OPERATING CONDITION	27
4.2.8 TEST RESULTS	28
4.3 TRANSMIT POWER MEASUREMENT	38
4.3.1 LIMITS OF TRANSMIT POWER MEASUREMENT	38
4.3.2 TEST INSTRUMENTS	38
4.3.3 TEST PROCEDURE	39
4.3.4 DEVIATION FROM TEST STANDARD	39
4.3.5 TEST SETUP	40
4.3.6 EUT OPERATING CONDITIONS	40
4.3.7 TEST RESULTS	41



A D T

4.4	OCCUPIED BANDWIDTH MEASUREMENT	43
4.4.1	TEST INSTRUMENTS.....	43
4.4.2	TEST PROCEDURE.....	43
4.4.3	DEVIATION FROM TEST STANDARD	43
4.4.4	TEST SETUP	43
4.4.5	EUT OPERATING CONDITIONS	43
4.4.6	TEST RESULTS	44
4.5	PEAK POWER SPECTRAL DENSITY MEASUREMENT	45
4.5.1	LIMITS OF PEAK POWER SPECTRAL DENSITY MEASUREMENT	45
4.5.2	TEST INSTRUMENTS.....	45
4.5.3	TEST PROCEDURES	45
4.5.4	DEVIATION FROM TEST STANDARD	45
4.5.5	TEST SETUP	45
4.5.6	EUT OPERATING CONDITIONS	45
4.5.7	TEST RESULTS	46
4.6	PEAK POWER EXCURSION MEASUREMENT	47
4.6.1	LIMITS OF PEAK POWER EXCURSION MEASUREMENT	47
4.6.2	TEST INSTRUMENTS.....	47
4.6.3	TEST PROCEDURE.....	47
4.6.4	DEVIATION FROM TEST STANDARD	47
4.6.5	TEST SETUP	47
4.6.6	EUT OPERATING CONDITIONS	47
4.6.7	TEST RESULTS	48
4.7	FREQUENCY STABILITY.....	57
4.7.1	LIMITS OF FREQUENCY STABILITY MEASUREMENT	57
4.7.2	TEST INSTRUMENTS.....	57
4.7.3	TEST PROCEDURE.....	57
4.7.4	DEVIATION FROM TEST STANDARD	58
4.7.5	TEST SETUP	58
4.7.6	EUT OPERATING CONDITION.....	58
4.7.7	TEST RESULTS	59
5.	PHOTOGRAPHS OF THE TEST CONFIGURATION.....	60
6.	INFORMATION ON THE TESTING LABORATORIES	61
7.	APPENDIX A - MODIFICATIONS RECORDERS FOR ENGINEERING CHANGES TO THE EUT BY THE LAB.....	62



A D T

RELEASE CONTROL RECORD

ISSUE NO.	REASON FOR CHANGE	DATE ISSUED
RF120302C25-1	Original release	Apr. 13, 2012



A D T

1. CERTIFICATION

PRODUCT: 450Mbps Wireless N Dual Band PCI Express Adapter
BRAND NAME: TP-LINK
MODEL NO.: TL-WDN4800
TEST SAMPLE: PROTOTYPE
APPLICANT: TP-LINK TECHNOLOGIES CO., LTD.
TESTED: Mar. 10 to 29, 2012
STANDARDS: FCC Part 15, Subpart E (Section 15.407)
ANSI C63.10-2009
Canada RSS-210 Issue 8 (2010-12)
Canada RSS-Gen Issue 3 (2010-12)

The above equipment (Model: TL-WDN4800) has been tested by **Bureau Veritas Consumer Products Services (H.K.) Ltd., Taoyuan Branch**, and found compliance with the requirement of the above standards. The test record, data evaluation & Equipment Under Test (EUT) configurations represented herein are true and accurate accounts of the measurements of the sample's EMC characteristics under the conditions specified in this report.

PREPARED BY :  , **DATE:** Apr. 13, 2012
(Lori Chung, Specialist)

APPROVED BY :  , **DATE:** Apr. 13, 2012
(May Chen, Deputy Manager)



A D T

2. SUMMARY OF TEST RESULTS

The EUT has been tested according to the following specifications:

For 5GHz, 5150~5250MHz

APPLIED STANDARD: FCC PART 15, SUBPART E (SECTION 15.407); RSS-210; RSS-Gen				
STANDARD SECTION		TEST TYPE	RESULT	REMARK
FCC PART 15	CANADA STANDARD			
15.407(b)(6)	RSS-Gen 7.2.4	AC Power Conducted Emission	PASS	Meet the requirement of limit. Minimum passing margin is -8.26dB at 0.20859MHz
-	RSS-Gen 4.6	Occupied Bandwidth Measurement	PASS	Meet the requirement of limit.
15.407(b/1/2/3) (b)(6)	RSS-210 A9.2	Spurious Emissions	PASS	Meet the requirement of limit. Minimum passing margin is -0.9dB at 5250.00MHz
15.407(a/1/2)	RSS-210 A9.2	Transmit Power	PASS	Meet the requirement of limit.
15.407(a)(6)	RSS-210 A9.2	Peak Power Excursion	PASS	Meet the requirement of limit.
15.407(a/1/2)	RSS-210 A9.2 A9.4 (2)	Peak Power Spectral Density	PASS	Meet the requirement of limit.
15.407(g)	RSS-Gen 4.7	Frequency Stability	PASS	Meet the requirement of limit.
15.203	-	Antenna Requirement	PASS	Antenna connector is SMA Reverse not a standard connector.

NOTE:

1. The EUT was operating in 2400 ~ 2483.5MHz, 5.15~5.25GHz and 5.725~5.850GHz frequencies band. This report was recorded the RF parameters including 5.15~5.25GHz. For the 2400 ~ 2483.5MHz and 5.725~5.850GHz RF parameters was recorded in another test report.



A D T

2.1 MEASUREMENT UNCERTAINTY

Where relevant, the following measurement uncertainty levels have been estimated for tests performed on the EUT as specified in CISPR 16-4-2:

This uncertainty represents an expanded uncertainty expressed at approximately the 95% confidence level using a coverage factor of $k=2$.

Measurement	Value
Conducted emissions	2.45 dB
Radiated emissions (30MHz-1GHz)	3.89 dB
Radiated emissions (1GHz -18GHz)	2.19 dB
Radiated emissions (18GHz -40GHz)	2.56 dB



A D T

3. GENERAL INFORMATION

3.1 GENERAL DESCRIPTION OF EUT

PRODUCT	450Mbps Wireless N Dual Band PCI Express Adapter
MODEL NO.	TL-WDN4800
POWER SUPPLY	DC 3.3V from host equipment
MODULATION TYPE	CCK, DQPSK, DBPSK for DSSS 64QAM, 16QAM, QPSK, BPSK for OFDM
MODULATION TECHNOLOGY	DSSS, OFDM
TRANSFER RATE	802.11b: up to 11Mbps 802.11a / g: up to 54Mbps 802.11n: up to 450Mbps
OPERATING FREQUENCY	For 15.407 / Annex 9 802.11a: 5.18 ~ 5.24GHz
	For 15.247 / Annex 8 802.11b/g: 2.412 ~ 2.462GHz 802.11a: 5.745 ~ 5.825GHz
NUMBER OF CHANNEL	For 15.407 / Annex 9 4 for 802.11a, 802.11n (20MHz) 2 for 802.11n (40MHz)
	For 15.247 (2.4GHz) / Annex 8 11 for 802.11b, 802.11g, 802.11n (20MHz) 7 for 802.11n (40MHz)
	For 15.247 (5GHz) / Annex 8 5 for 802.11a, 802.11n (20MHz) 2 for 802.11n (40MHz)



A D T

MAXIMUM OUTPUT POWER	For 15.407 / Annex 9 802.11a: 13.87mW 802.11n (20MHz): 13.241mW 802.11n (40MHz): 15.303mW For 15.247 (2.4GHz) / Annex 8 802.11b: 231.149mW 802.11g: 688.102mW 802.11n (20MHz): 527.839mW 802.11n (40MHz): 219.005mW For 15.247 (5GHz) / Annex 8 802.11a: 155.431mW 802.11n (20MHz): 156.926mW 802.11n (40MHz): 169.013mW
ANTENNA TYPE	Please see NOTE
DATA CABLE	NA
I/O PORTS	Refer to user's manual
ASSOCIATED DEVICES	NA

NOTE:

1. The antennas provided to the EUT, please refer to the following table:

Transmitter Circuit	Antenna Type	Peak Gain (dBi)	Connector Type
Chain (0)	Omni	2	SMA Reverse
Chain (1)	Omni	2	SMA Reverse
Chain (2)	Omni	2	SMA Reverse

2. The EUT incorporates a MIMO function. Physically, the EUT provides three completed transmitters and three receivers.

MODULATION MODE	TX/RX FUNCTION
802.11b	3Tx/3Rx
802.11g	3Tx/3Rx
802.11a	3Tx/3Rx
802.11n (20MHz)	3Tx/3Rx
802.11n (40MHz)	3Tx/3Rx

3. The EUT is 3 * 3 spatial MIMO (3Tx & 3Rx) without beam forming function.
4. The EUT incorporates CDD function with 802.11a, 802.11b, 802.11g.
5. When the EUT operating in 802.11n, the software operation, which is defined by manufacturer, MCS (Modulation and Coding Schemes) from 0 to 23.

The above EUT information was declared by the manufacturer and for more detailed features description, please refer to the manufacturer's specifications or User's Manual.



A D T

3.2 DESCRIPTION OF TEST MODES

Operated in 5150MHz ~ 5250MHz bands:

Four channels are provided for 802.11a and 802.11n (20MHz):

CHANNEL	FREQUENCY
36	5180 MHz
40	5200 MHz
44	5220 MHz
48	5240 MHz

Two channels are provided for 802.11n (40MHz):

CHANNEL	FREQUENCY
38	5190 MHz
46	5230 MHz

3.2.1 TEST MODE APPLICABILITY AND TESTED CHANNEL DETAIL

EUT CONFIGURE MODE	APPLICABLE TO					DESCRIPTION
	PLC	RE < 1G	RE ≥ 1G	APCM	OB	
-	√	√	√	√	√	-

Where **PLC**: Power Line Conducted Emission **RE < 1G**: Radiated Emission below 1GHz
RE ≥ 1G: Radiated Emission above 1GHz **APCM**: Antenna Port Conducted Measurement
OB: Conducted Out-Band Emission Measurement

POWER LINE CONDUCTED EMISSION TEST:

- Pre-Scan has been conducted to determine the worst-case mode from all possible combinations between available modulations, data rates and antenna ports (if EUT with antenna diversity architecture).
- Following channel(s) was (were) selected for the final test as listed below.

MODE	AVAILABLE CHANNEL	TESTED CHANNEL	MODULATION TECHNOLOGY	MODULATION TYPE	DATA RATE (MBPS)
802.11a	36 to 48	36	OFDM	BPSK	6

RADIATED EMISSION TEST (BELOW 1 GHz):

- Pre-Scan has been conducted to determine the worst-case mode from all possible combinations between available modulations, data rates and antenna ports (if EUT with antenna diversity architecture).
- Following channel(s) was (were) selected for the final test as listed below.

MODE	AVAILABLE CHANNEL	TESTED CHANNEL	MODULATION TECHNOLOGY	MODULATION TYPE	DATA RATE (Mbps)
802.11a	36 to 48	36	OFDM	BPSK	6

RADIATED EMISSION TEST (ABOVE 1 GHz):

- Pre-Scan has been conducted to determine the worst-case mode from all possible combinations between available modulations, data rates and antenna ports (if EUT with antenna diversity architecture).
- Following channel(s) was (were) selected for the final test as listed below.

MODE	AVAILABLE CHANNEL	TESTED CHANNEL	MODULATION TECHNOLOGY	MODULATION TYPE	DATA RATE (Mbps)
802.11a	36 to 48	36, 40, 48	OFDM	BPSK	6
For 5 GHz 802.11n (20MHz)	36 to 48	36, 40, 48	OFDM	BPSK	6.5
For 5 GHz 802.11n (40MHz)	38 to 46	38, 46	OFDM	BPSK	13.5

ANTENNA PORT CONDUCTED MEASUREMENT:

- Pre-Scan has been conducted to determine the worst-case mode from all possible combinations between available modulations, data rates and antenna ports (if EUT with antenna diversity architecture).
- Following channel(s) was (were) selected for the final test as listed below.

MODE	AVAILABLE CHANNEL	TESTED CHANNEL	MODULATION TECHNOLOGY	MODULATION TYPE	DATA RATE (Mbps)
802.11a	36 to 48	36, 40, 48	OFDM	BPSK	6
For 5 GHz 802.11n (20MHz)	36 to 48	36, 40, 48	OFDM	BPSK	6.5
For 5 GHz 802.11n (40MHz)	38 to 46	38, 46	OFDM	BPSK	13.5

TEST CONDITION:

APPLICABLE TO	ENVIRONMENTAL CONDITIONS	INPUT POWER	TESTED BY
PLC	22deg. C, 64%RH	120Vac, 60Hz	Kyle Huang
RE<1G	23deg. C, 70%RH	120Vac, 60Hz	Amos Chuang
RE ³ 1G	23deg. C, 71%RH	120Vac, 60Hz	Amos Chuang
APCM	25deg. C, 60%RH	120Vac, 60Hz	Rex Huang
OB	25deg. C, 60%RH	120Vac, 60Hz	Rex Huang

3.3 GENERAL DESCRIPTION OF APPLIED STANDARDS

The EUT is a RF product. According to the specifications of the manufacturer, it must comply with the requirements of the following standards:

FCC Part 15, Subpart C (Section 15.247)

ANSI C63.10-2009

Canada RSS-210 Issue 8 (2010-12)

Canada RSS-Gen Issue 3 (2010-12)

All test items have been performed and recorded as per the above standards.

NOTE:

1. This device support multiple outputs in the same band, therefore test methodology will be following FCC KDB 662911 requirements.
2. The EUT is also considered as a kind of computer peripheral, because the connection to computer is necessary for typical use. It has been verified to comply with the requirements of FCC Part 15, Subpart B, Class B (DoC). The test report has been issued separately.

3.4 DUTY CYCLE OF TEST SIGNAL

Test tool can set the EUT to transmit at > 98 % duty cycle.



A D T

3.5 DESCRIPTION OF SUPPORT UNITS

The EUT has been tested as an independent unit together with other necessary accessories or support units. The following support units or accessories were used to form a representative test configuration during the tests.

NO.	PRODUCT	BRAND	MODEL NO.	SERIAL NO.	FCC ID
1	PERSONAL COMPUTER (For conducted emission test)	DELL	DCSCMF	9KKB32S	FCC DoC
	PERSONAL COMPUTER (For other test items)	DELL	DCNE	HRJB32S	FCC DoC
2	MONITOR	DELL	E2210Hc	CN-OG337R-6418 0-97S-OQDS	FCC DoC
3	PRINTER (For conducted emission test)	EPSON	LQ-300+II	G88Y074083	FCC DoC
	PRINTER (For other test items)	EPSON	LQ-300+II	G88Y074015	FCC DoC
4	MODEM	ACEEX	1414	0206026778	IFAXDM1414
5	KEYBOARD	DELL	SK-8115	MY-0DJ325-71619 -99B-0476	FCC DoC
6	MOUSE (For conducted emission test)	DELL	MOC5UO	I1401LVG	FCC DoC
	MOUSE (For other test items)	DELL	MOC5UO	I14066PS	FCC DoC
7	WIRELESS AP	Linksys	WRT160N V3	NA	NA

NO.	SIGNAL CABLE DESCRIPTION OF THE ABOVE SUPPORT UNITS
1	NA
2	VGA cable (1.4m), with 2 cores
3	USB cable (1.8m)
4	RS232 cable (1m) / RS232 cable (1.1m)
5	USB cable (1.8m), with 1 core
6	USB cable (1.5m) / USB cable (1.8m)
7	NA

NOTE: All power cords of the above support units are non shielded (1.8m).

3.6 CONFIGURATION OF SYSTEM UNDER TEST

For conducted emission test:

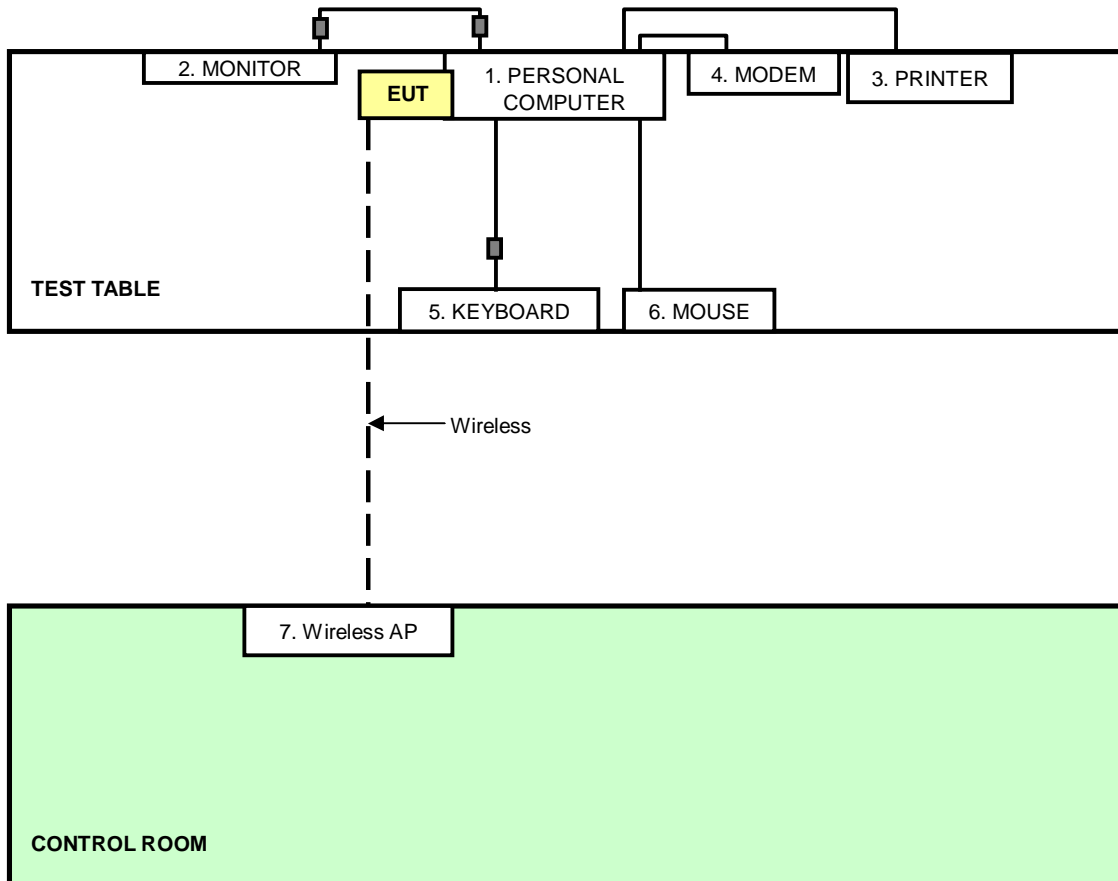

For other test items:

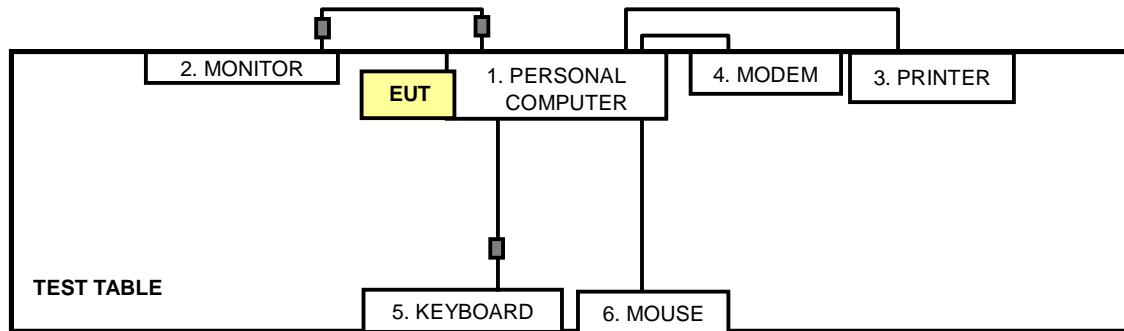



A D T

4. TEST TYPES AND RESULTS

4.1 CONDUCTED EMISSION MEASUREMENT

4.1.1 LIMITS OF CONDUCTED EMISSION MEASUREMENT

FREQUENCY OF EMISSION (MHz)	CONDUCTED LIMIT (dB μ V)	
	Quasi-peak	Average
0.15-0.5	66 to 56	56 to 46
0.5-5	56	46
5-30	60	50

- NOTE:** 1. The lower limit shall apply at the transition frequencies.
2. The limit decreases in line with the logarithm of the frequency in the range of 0.15 to 0.50 MHz.

4.1.2 TEST INSTRUMENTS

DESCRIPTION & MANUFACTURER	MODEL NO.	SERIAL NO.	CALIBRATED DATE	CALIBRATED UNTIL
ROHDE & SCHWARZ Test Receiver	ESCS 30	100287	Feb. 29, 2012	Feb. 28, 2013
Line-Impedance Stabilization Network (for EUT)	NSLK 8127	8127-523	Sep. 20, 2011	Sep. 19, 2012
Line-Impedance Stabilization Network (for Peripheral)	ENV-216	100072	June 10, 2011	June 09, 2012
RF Cable (JYEBAO)	5DFB	COACAB-002	Aug. 06, 2011	Aug. 05, 2012
50 ohms Terminator	50	3	Nov. 02, 2011	Nov. 01, 2012
Software	BV ADT_Cond_V7.3.7	NA	NA	NA

Note:

1. The calibration interval of the above test instruments is 12 months and the calibrations are traceable to NML/ROC and NIST/USA.
2. The test was performed in Shielded Room No. A.
3. The VCCI Con A Registration No. is C-817.
4. Tested Date: Mar. 29, 2012.



A D T

4.1.3 TEST PROCEDURES

- a. The EUT was placed 0.4 meters from the conducting wall of the shielded room with EUT being connected to the power mains through a line impedance stabilization network (LISN). Other support units were connected to the power mains through another LISN.
- b. The two LISNs provide 50 ohm/ 50uH of coupling impedance for the measuring instrument.
- c. Both lines of the power mains connected to the EUT were checked for maximum conducted interference.
- d. The frequency range from 150kHz to 30MHz was searched. Emission level under (Limit – 20dB) was not recorded.

4.1.4 DEVIATION FROM TEST STANDARD

No deviation

4.1.5 TEST SETUP

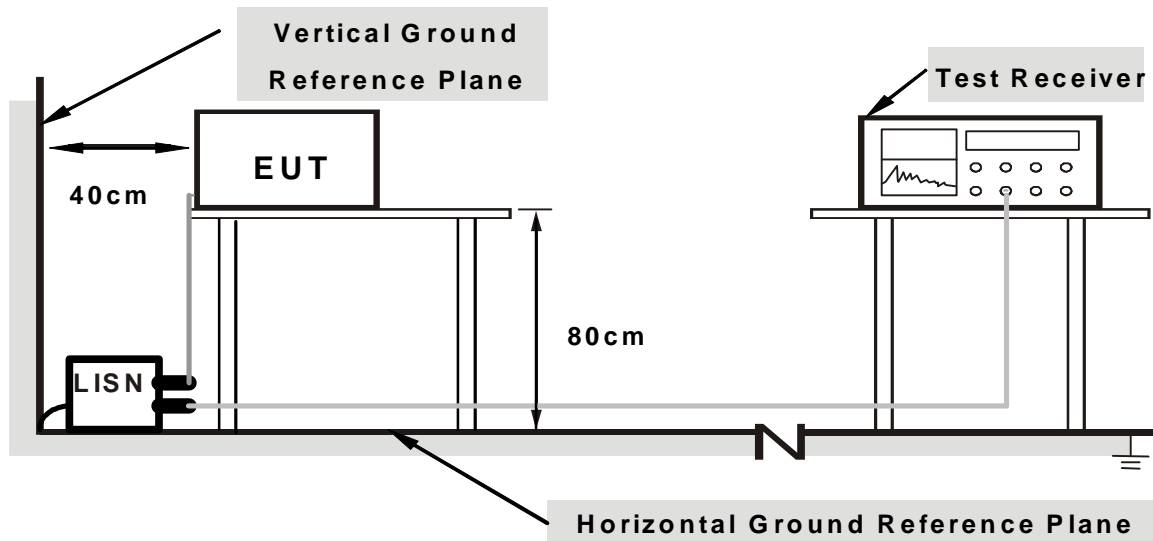

Note: 1. Support units were connected to second LISN.

2. Both of LISNs (AMN) are 80 cm from EUT and at least 80 from other units and other metal planes

For the actual test configuration, please refer to the related item – Photographs of the Test Configuration.

4.1.6 EUT OPERATING CONDITIONS

1. Connect the EUT with the support unit 1 (PC) which is placed on a testing table.
2. The support unit 1 (PC) runs a test program “Ping. exe” to enable EUT under transmission/receiving condition continuously with support unit 7 (Wireless AP) via wireless.

4.1.7 TEST RESULTS

PHASE	Line (L)	6dB BANDWIDTH	9 kHz
--------------	----------	----------------------	-------

No	Freq. [MHz]	Corr. Factor (dB)	Reading Value		Emission Level		Limit		Margin	
			[dB (uV)]		[dB (uV)]		[dB (uV)]		(dB)	
			Q.P.	AV.	Q.P.	AV.	Q.P.	AV.	Q.P.	AV.
1	0.16497	0.06	39.88	39.35	39.94	39.41	65.21	55.21	-25.27	-15.80
2	0.20859	0.06	39.58	38.22	39.64	38.28	63.26	53.26	-23.62	-14.98
3	0.27500	0.06	31.66	27.11	31.72	27.17	60.97	50.97	-29.24	-23.79
4	0.46250	0.08	32.05	28.94	32.13	29.02	56.65	46.65	-24.52	-17.63
5	0.90000	0.11	33.17	32.99	33.28	33.10	56.00	46.00	-22.72	-12.90
6	18.03125	0.58	33.12	32.17	33.70	32.75	60.00	50.00	-26.30	-17.25

- REMARKS:**
1. Q.P. and AV. are abbreviations of quasi-peak and average individually.
 2. The emission levels of other frequencies were very low against the limit.
 3. Margin value = Emission level - Limit value
 4. Correction factor = Insertion loss + Cable loss
 5. Emission Level = Correction Factor + Reading Value.

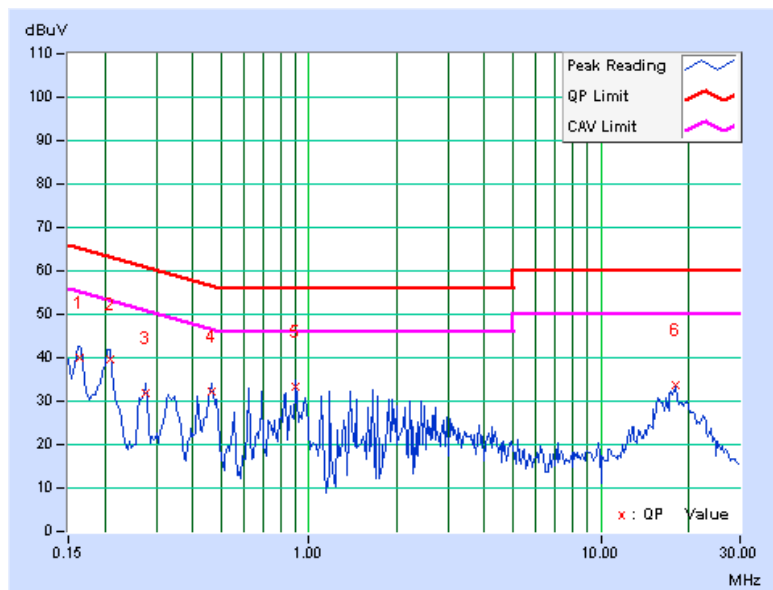

PHASE	Neutral (N)	6dB BANDWIDTH	9 kHz
--------------	-------------	----------------------	-------

No	Freq. [MHz]	Corr. Factor (dB)	Reading Value [dB (uV)]		Emission Level [dB (uV)]		Limit [dB (uV)]		Margin (dB)	
			Q.P.	AV.	Q.P.	AV.	Q.P.	AV.	Q.P.	AV.
			1	0.16172	0.07	40.39	39.80	40.46	39.87	65.38
2	0.20859	0.07	45.23	44.93	45.30	45.00	63.26	53.26	-17.96	-8.26
3	0.27500	0.07	36.50	33.27	36.57	33.34	60.97	50.97	-24.39	-17.62
4	0.34531	0.08	36.64	35.68	36.72	35.76	59.07	49.07	-22.36	-13.32
5	1.44922	0.15	26.62	21.49	26.77	21.64	56.00	46.00	-29.23	-24.36
6	18.03125	0.56	32.88	32.09	33.44	32.65	60.00	50.00	-26.56	-17.35

- REMARKS:**
1. Q.P. and AV. are abbreviations of quasi-peak and average individually.
 2. The emission levels of other frequencies were very low against the limit.
 3. Margin value = Emission level - Limit value
 4. Correction factor = Insertion loss + Cable loss
 5. Emission Level = Correction Factor + Reading Value.

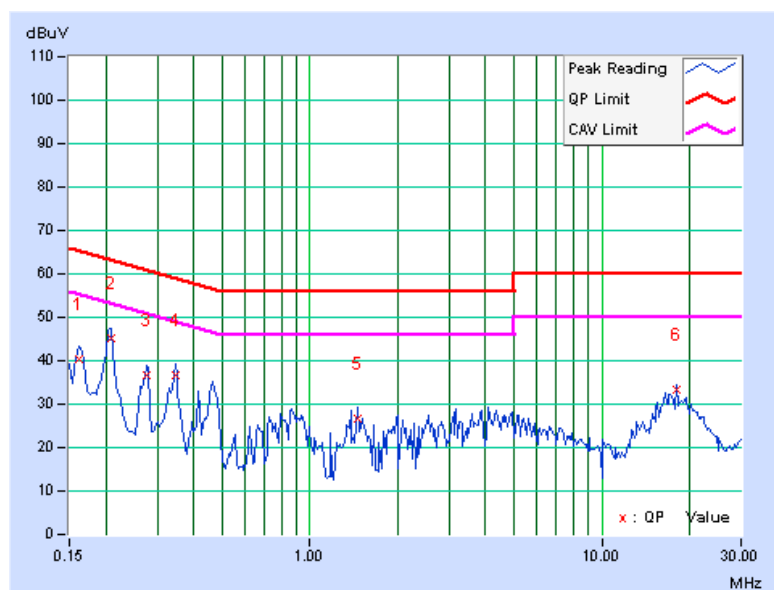

4.2 RADIATED EMISSION MEASUREMENT

4.2.1 LIMITS OF RADIATED EMISSION MEASUREMENT

Radiated emissions which fall in the restricted bands must comply with the radiated emission limits specified as below table:

Frequencies (MHz)	Field strength (microvolts/meter)	Measurement distance (meters)
0.009-0.490	2400/F(kHz)	300
0.490-1.705	24000/F(kHz)	30
1.705-30.0	30	30
30-88	100	3
88-216	150	3
216-960	200	3
Above 960	500	3

NOTE:

1. The lower limit shall apply at the transition frequencies.
2. Emission level (dBuV/m) = 20 log Emission level (uV/m).
3. For frequencies above 1000MHz, the field strength limits are based on average detector, however, the peak field strength of any emission shall not exceed the maximum permitted average limits, specified above by more than 20dB under any condition of modulation.



A D T

4.2.2 LIMITS OF UNWANTED EMISSION OUT OF THE RESTRICTED BANDS

Frequencies (MHz)	EIRP Limit (dBm)	Equivalent Field Strength at 3m (dBµV/m) *note 3
5150~5250	-27	68.3
5250~5350	-27	68.3
5470~5725	-27	68.3
5725~5825	-27 *note 1	68.3
	-17 *note 2	78.3

NOTE:

1. For frequencies 10MHz or greater above or below the band edge.
2. All emissions within the frequency range from the band edge to 10MHz above or below the band edge.
3. The following formula is used to convert the equipment isotropic radiated power (eirp) to field strength

$$E = \frac{1000000\sqrt{30P}}{3} \text{ } \mu\text{V/m, where P is the eirp (Watts)}$$



A D T

4.2.3 TEST INSTRUMENTS

DESCRIPTION & MANUFACTURER	MODEL NO.	SERIAL NO.	CALIBRATED DATE	CALIBRATED UNTIL
Agilent Spectrum Analyzer	E4446A	MY48250253	Aug. 29, 2011	Aug. 28, 2012
Agilent Pre-Selector	N9039A	MY46520310	Aug. 29, 2011	Aug. 28, 2012
Agilent Signal Generator	N5181A	MY49060347	July 25, 2011	July 24, 2012
Mini-Circuits Pre-Amplifier	ZFL-1000VH2B	AMP-ZFL-04	Nov. 15, 2011	Nov. 14, 2012
Agilent Pre-Amplifier	8449B	3008A02465	Feb. 27, 2012	Feb. 26, 2013
SPACEK LABS	SLKKa-48-6	9K16	Nov. 15, 2011	Nov. 14, 2012
SCHWARZBECK Trilog Broadband Antenna	VULB 9168	9168-361	Apr. 14, 2011	Apr. 13, 2012
AISI Horn_Antenna	AIH.8018	0000220091110	Nov. 23, 2011	Nov. 22, 2012
SCHWARZBECK Horn_Antenna	BBHA 9170	9170-424	Oct. 07, 2011	Oct. 06, 2012
RF CABLE	NA	RF104-205 RF104-207 RF104-202	Dec. 27, 2011	Dec. 26, 2012
RF Cable	NA	CHHCAB_001	Oct. 08, 2011	Oct. 07, 2012
Software	ADT_Radiated_V8.7.05	NA	NA	NA
CT Antenna Tower & Turn Table	NA	NA	NA	NA

- Note: 1. The calibration interval of the above test instruments is 12 months and the calibrations are traceable to NML/ROC and NIST/USA.
2. The horn antenna, preamplifier (model: 8449B) are used only for the measurement of emission frequency above 1GHz if tested.
3. The test was performed in 966 Chamber No. H.
4. The FCC Site Registration No. is 797305.
5. The CANADA Site Registration No. is IC 7450H-3.
6. Tested Date: Mar. 10, 2012.

4.2.4 TEST PROCEDURES

- a. The EUT was placed on the top of a rotating table 0.8 meters above the ground at a 3 meter chamber room. The table was rotated 360 degrees to determine the position of the highest radiation.
- b. The EUT was set 3 meters away from the interference-receiving antenna, which was mounted on the top of a variable-height antenna tower.
- c. The height of antenna is varied from one meter to four meters above the ground to determine the maximum value of the field strength. Both horizontal and vertical polarizations of the antenna are set to make the measurement.
- d. For each suspected emission, the EUT was arranged to its worst case and then the antenna was tuned to heights from 1 meter to 4 meters and the rotatable table was turned from 0 degrees to 360 degrees to find the maximum reading.
- e. The test-receiver system was set to quasi-peak detect function and specified bandwidth with maximum hold mode when the test frequency is below 1 GHz.
- f. The test-receiver system was set to peak and average detect function and specified bandwidth with maximum hold mode when the test frequency is above 1 GHz. If the peak reading value also meets average limit, measurement with the average detector is unnecessary.

NOTE:

1. The resolution bandwidth and video bandwidth of test receiver/spectrum analyzer is 120kHz for Quasi-peak detection (QP) at frequency below 1GHz.
2. The resolution bandwidth of test receiver/spectrum analyzer is 1 MHz and the video bandwidth is 3 MHz for Peak detection (PK) at frequency above 1GHz.
3. The resolution bandwidth of test receiver/spectrum analyzer is 1 MHz and the video bandwidth is 10 Hz for Average detection (AV) at frequency above 1GHz.
4. All modes of operation were investigated and the worst-case emissions are reported.

4.2.5 DEVIATION FROM TEST STANDARD

No deviation

4.2.6 TEST SETUP

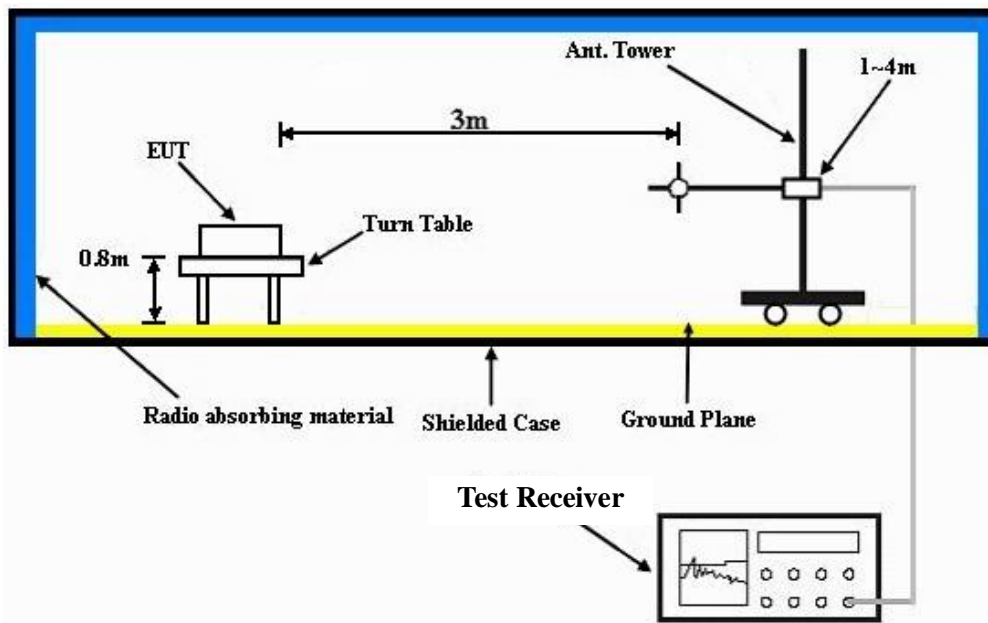

For the actual test configuration, please refer to the related item – Photographs of the Test Configuration.

4.2.7 EUT OPERATING CONDITION

1. Placed the EUT on testing table.
2. Prepared other computer system (support unit 1) to act as communication partners.
3. The communication partners ran test program “artgui.exe” to enable EUT under transmission/receiving condition continuously.

4.2.8 TEST RESULTS

BELOW 1GHz WORST-CASE DATA

802.11a

CHANNEL	TX Channel 36	DETECTOR FUNCTION	Quasi-Peak (QP)
FREQUENCY RANGE	Below 1GHz		

ANTENNA POLARITY & TEST DISTANCE: HORIZONTAL AT 3 M								
NO.	FREQ. (MHz)	EMISSION LEVEL (dBuV/m)	LIMIT (dBuV/m)	MARGIN (dB)	ANTENNA HEIGHT (m)	TABLE ANGLE (Degree)	RAW VALUE (dBuV)	CORRECTION FACTOR (dB/m)
1	101.17	26.4 QP	43.5	-17.1	2.00 H	99	16.71	9.65
2	329.96	23.2 QP	46.0	-22.8	1.00 H	227	7.13	16.07
3	375.08	23.2 QP	46.0	-22.8	2.00 H	240	6.06	17.11
4	566.34	25.9 QP	46.0	-20.1	1.50 H	53	4.34	21.52
5	696.96	29.1 QP	46.0	-17.0	1.50 H	41	5.98	23.07
6	763.27	32.1 QP	46.0	-13.9	1.00 H	234	7.47	24.60

REMARKS:

1. Emission level (dBuV/m) = Raw Value (dBuV) + Correction Factor (dB/m).
2. Correction Factor (dB/m) = Antenna Factor (dB/m) + Cable Factor (dB).
3. The other emission levels were very low against the limit.
4. Margin value = Emission level – Limit value.

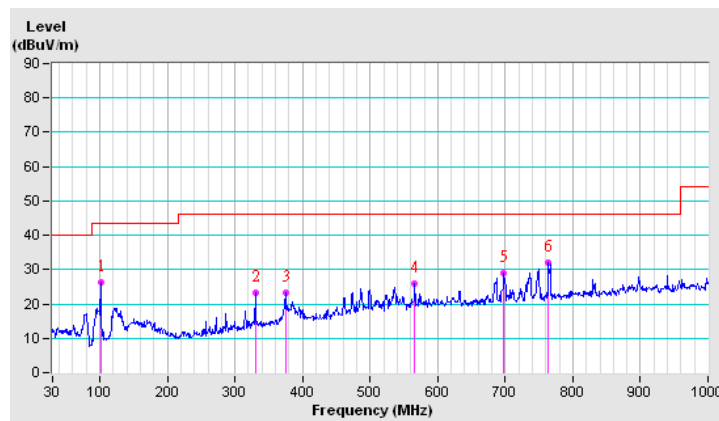



A D T

CHANNEL	TX Channel 36	DETECTOR FUNCTION	Quasi-Peak (QP)
FREQUENCY RANGE	Below 1GHz		

ANTENNA POLARITY & TEST DISTANCE: VERTICAL AT 3 M								
NO.	FREQ. (MHz)	EMISSION LEVEL (dBuV/m)	LIMIT (dBuV/m)	MARGIN (dB)	ANTENNA HEIGHT (m)	TABLE ANGLE (Degree)	RAW VALUE (dBuV)	CORRECTION FACTOR (dB/m)
1	30.12	24.8 QP	40.0	-15.2	1.00 V	203	11.72	13.09
2	329.96	25.1 QP	46.0	-20.9	1.50 V	176	9.06	16.07
3	374.97	33.5 QP	46.0	-12.5	1.50 V	192	16.38	17.10
4	486.40	28.3 QP	46.0	-17.7	1.00 V	129	8.58	19.73
5	698.61	36.8 QP	46.0	-9.2	1.50 V	146	13.71	23.09
6	940.67	33.2 QP	46.0	-12.8	1.00 V	360	5.62	27.54

REMARKS:

1. Emission level (dBuV/m) = Raw Value (dBuV) + Correction Factor (dB/m).
2. Correction Factor (dB/m) = Antenna Factor (dB/m) + Cable Factor (dB).
3. The other emission levels were very low against the limit.
4. Margin value = Emission level – Limit value.

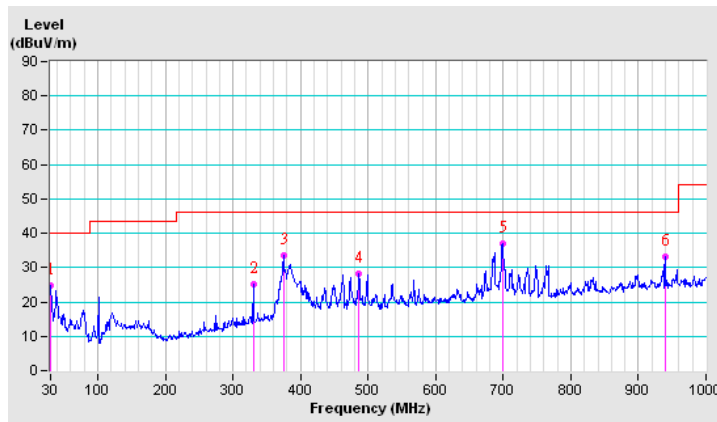



ABOVE 1GHz DATA

802.11a

CHANNEL	TX Channel 36	DETECTOR FUNCTION	Peak (PK)
FREQUENCY RANGE	1GHz ~ 40GHz		Average (AV)

ANTENNA POLARITY & TEST DISTANCE: HORIZONTAL AT 3 M

NO.	FREQ. (MHz)	EMISSION LEVEL (dBuV/m)	LIMIT (dBuV/m)	MARGIN (dB)	ANTENNA HEIGHT (m)	TABLE ANGLE (Degree)	RAW VALUE (dBuV)	CORRECTION FACTOR (dB/m)
1	5040.00	59.5 PK	74.0	-14.5	1.10 H	42	22.92	36.58
2	5040.00	47.6 AV	54.0	-6.4	1.10 H	42	11.02	36.58
3	*5180.00	102.1 PK			1.09 H	43	65.34	36.76
4	*5180.00	92.8 AV			1.09 H	43	56.04	36.76
5	#10360.00	56.6 PK	68.3	-11.7	1.00 H	30	10.24	46.36
6	15540.00	63.5 PK	74.0	-10.5	1.27 H	183	15.35	48.15
7	15540.00	51.0 AV	54.0	-3.0	1.27 H	183	2.85	48.15

ANTENNA POLARITY & TEST DISTANCE: VERTICAL AT 3 M

NO.	FREQ. (MHz)	EMISSION LEVEL (dBuV/m)	LIMIT (dBuV/m)	MARGIN (dB)	ANTENNA HEIGHT (m)	TABLE ANGLE (Degree)	RAW VALUE (dBuV)	CORRECTION FACTOR (dB/m)
1	5040.00	59.5 PK	74.0	-14.5	1.27 V	44	22.92	36.58
2	5040.00	48.9 AV	54.0	-5.1	1.27 V	44	12.32	36.58
3	*5180.00	112.6 PK			1.24 V	44	75.84	36.76
4	*5180.00	102.1 AV			1.24 V	44	65.34	36.76
5	5400.00	61.3 PK	74.0	-12.7	1.30 V	43	24.28	37.02
6	5400.00	51.3 AV	54.0	-2.7	1.30 V	43	14.28	37.02
7	#10360.00	56.4 PK	68.3	-11.9	1.00 V	156	10.04	46.36
8	15540.00	63.7 PK	74.0	-10.3	1.00 V	234	15.55	48.15
9	15540.00	51.3 AV	54.0	-2.7	1.00 V	234	3.15	48.15

REMARKS:

1. Emission level (dBuV/m) = Raw Value (dBuV) + Correction Factor (dB/m).
2. Correction Factor (dB/m) = Antenna Factor (dB/m) + Cable Factor (dB).
3. The other emission levels were very low against the limit.
4. Margin value = Emission level – Limit value.
5. " * ": Fundamental frequency.
6. " # ": The radiated frequency is out of the restricted band.



A D T

CHANNEL	TX Channel 40	DETECTOR FUNCTION	Peak (PK)
FREQUENCY RANGE	1GHz ~ 40GHz		Average (AV)

ANTENNA POLARITY & TEST DISTANCE: HORIZONTAL AT 3 M

NO.	FREQ. (MHz)	EMISSION LEVEL (dBuV/m)	LIMIT (dBuV/m)	MARGIN (dB)	ANTENNA HEIGHT (m)	TABLE ANGLE (Degree)	RAW VALUE (dBuV)	CORRECTION FACTOR (dB/m)
1	*5200.00	102.5 PK			1.07 H	41	65.71	36.79
2	*5200.00	92.7 AV			1.07 H	41	55.91	36.79
3	#10400.00	56.4 PK	68.3	-11.9	1.00 H	33	9.91	46.49
4	15600.00	63.5 PK	74.0	-10.5	1.27 H	194	15.65	47.85
5	15600.00	51.2 AV	54.0	-2.8	1.27 H	194	3.35	47.85

ANTENNA POLARITY & TEST DISTANCE: VERTICAL AT 3 M

NO.	FREQ. (MHz)	EMISSION LEVEL (dBuV/m)	LIMIT (dBuV/m)	MARGIN (dB)	ANTENNA HEIGHT (m)	TABLE ANGLE (Degree)	RAW VALUE (dBuV)	CORRECTION FACTOR (dB/m)
1	*5200.00	111.5 PK			1.22 V	50	74.71	36.79
2	*5200.00	102.0 AV			1.22 V	50	65.21	36.79
3	5400.00	61.5 PK	74.0	-12.5	1.30 V	45	24.48	37.02
4	5400.00	51.6 AV	54.0	-2.4	1.30 V	45	14.58	37.02
5	#10400.00	56.3 PK	68.3	-12.0	1.00 V	151	9.81	46.49
6	15600.00	63.9 PK	74.0	-10.1	1.02 V	225	16.05	47.85
7	15600.00	51.5 AV	54.0	-2.5	1.02 V	225	3.65	47.85

REMARKS:

1. Emission level (dBuV/m) = Raw Value (dBuV) + Correction Factor (dB/m).
2. Correction Factor (dB/m) = Antenna Factor (dB/m) + Cable Factor (dB).
3. The other emission levels were very low against the limit.
4. Margin value = Emission level – Limit value.
5. " * ": Fundamental frequency.
6. " # ": The radiated frequency is out of the restricted band.



A D T

CHANNEL	TX Channel 48	DETECTOR FUNCTION	Peak (PK)
FREQUENCY RANGE	1GHz ~ 40GHz		Average (AV)

ANTENNA POLARITY & TEST DISTANCE: HORIZONTAL AT 3 M

NO.	FREQ. (MHz)	EMISSION LEVEL (dBuV/m)	LIMIT (dBuV/m)	MARGIN (dB)	ANTENNA HEIGHT (m)	TABLE ANGLE (Degree)	RAW VALUE (dBuV)	CORRECTION FACTOR (dB/m)
1	*5240.00	102.3 PK			1.06 H	42	65.43	36.87
2	*5240.00	91.7 AV			1.06 H	42	54.83	36.87
3	#5250.00	67.0 PK	68.3	-1.3	1.06 H	77	30.12	36.88
4	5350.00	58.9 PK	74.0	-15.1	1.05 H	43	21.90	37.00
5	5350.00	46.6 AV	54.0	-7.4	1.05 H	43	9.60	37.00
6	#10480.00	56.5 PK	68.3	-11.8	1.01 H	35	10.06	46.44
7	15720.00	63.8 PK	74.0	-10.2	1.26 H	177	15.74	48.06
8	15720.00	51.5 AV	54.0	-2.5	1.26 H	177	3.44	48.06

ANTENNA POLARITY & TEST DISTANCE: VERTICAL AT 3 M

NO.	FREQ. (MHz)	EMISSION LEVEL (dBuV/m)	LIMIT (dBuV/m)	MARGIN (dB)	ANTENNA HEIGHT (m)	TABLE ANGLE (Degree)	RAW VALUE (dBuV)	CORRECTION FACTOR (dB/m)
1	*5240.00	110.3 PK			1.24 V	46	73.43	36.87
2	*5240.00	101.4 AV			1.24 V	46	64.53	36.87
3	#5250.00	66.9 PK	68.3	-1.4	1.24 V	50	30.02	36.88
4	5400.00	60.9 PK	74.0	-13.1	1.30 V	45	23.88	37.02
5	5400.00	51.9 AV	54.0	-2.1	1.30 V	45	14.88	37.02
6	#10480.00	56.3 PK	68.3	-12.0	1.00 V	153	9.86	46.44
7	15720.00	64.2 PK	74.0	-9.8	1.02 V	243	16.14	48.06
8	15720.00	51.6 AV	54.0	-2.4	1.02 V	243	3.54	48.06

REMARKS:

1. Emission level (dBuV/m) = Raw Value (dBuV) + Correction Factor (dB/m).
2. Correction Factor (dB/m) = Antenna Factor (dB/m) + Cable Factor (dB).
3. The other emission levels were very low against the limit.
4. Margin value = Emission level – Limit value.
5. " * ": Fundamental frequency.
6. " # ": The radiated frequency is out of the restricted band.



A D T

802.11n (20MHz)

CHANNEL	TX Channel 36	DETECTOR FUNCTION	Peak (PK)
FREQUENCY RANGE	1GHz ~ 40GHz		Average (AV)

ANTENNA POLARITY & TEST DISTANCE: HORIZONTAL AT 3 M								
NO.	FREQ. (MHz)	EMISSION LEVEL (dBuV/m)	LIMIT (dBuV/m)	MARGIN (dB)	ANTENNA HEIGHT (m)	TABLE ANGLE (Degree)	RAW VALUE (dBuV)	CORRECTION FACTOR (dB/m)
1	5040.00	58.3 PK	74.0	-15.7	1.05 H	50	21.72	36.58
2	5040.00	46.8 AV	54.0	-7.2	1.05 H	50	10.22	36.58
3	*5180.00	102.3 PK			1.07 H	41	65.54	36.76
4	*5180.00	92.9 AV			1.07 H	41	56.14	36.76
5	#10360.00	56.6 PK	68.3	-11.7	1.00 H	32	10.24	46.36
6	15540.00	63.6 PK	74.0	-10.4	1.25 H	179	15.45	48.15
7	15540.00	51.3 AV	54.0	-2.7	1.25 H	179	3.15	48.15
ANTENNA POLARITY & TEST DISTANCE: VERTICAL AT 3 M								
NO.	FREQ. (MHz)	EMISSION LEVEL (dBuV/m)	LIMIT (dBuV/m)	MARGIN (dB)	ANTENNA HEIGHT (m)	TABLE ANGLE (Degree)	RAW VALUE (dBuV)	CORRECTION FACTOR (dB/m)
1	5120.00	59.9 PK	74.0	-14.1	1.27 V	46	23.24	36.66
2	5120.00	49.1 AV	54.0	-4.9	1.27 V	46	12.44	36.66
3	*5180.00	110.4 PK			1.26 V	45	73.64	36.76
4	*5180.00	101.1 AV			1.26 V	45	64.34	36.76
5	5400.00	60.3 PK	74.0	-13.7	1.26 V	59	23.28	37.02
6	5400.00	51.6 AV	54.0	-2.4	1.26 V	59	14.58	37.02
7	#10360.00	56.4 PK	68.3	-11.9	1.00 V	155	10.04	46.36
8	15540.00	63.7 PK	74.0	-10.3	1.00 V	230	15.55	48.15
9	15540.00	51.3 AV	54.0	-2.7	1.00 V	230	3.15	48.15

REMARKS:

1. Emission level (dBuV/m) = Raw Value (dBuV) + Correction Factor (dB/m).
2. Correction Factor (dB/m) = Antenna Factor (dB/m) + Cable Factor (dB).
3. The other emission levels were very low against the limit.
4. Margin value = Emission level – Limit value.
5. " * ": Fundamental frequency.
6. " # ": The radiated frequency is out of the restricted band.



A D T

CHANNEL	TX Channel 40	DETECTOR FUNCTION	Peak (PK)
FREQUENCY RANGE	1GHz ~ 40GHz		Average (AV)

ANTENNA POLARITY & TEST DISTANCE: HORIZONTAL AT 3 M

NO.	FREQ. (MHz)	EMISSION LEVEL (dBuV/m)	LIMIT (dBuV/m)	MARGIN (dB)	ANTENNA HEIGHT (m)	TABLE ANGLE (Degree)	RAW VALUE (dBuV)	CORRECTION FACTOR (dB/m)
1	*5200.00	101.4 PK			1.05 H	40	64.61	36.79
2	*5200.00	92.7 AV			1.05 H	40	55.91	36.79
3	#10400.00	56.4 PK	68.3	-11.9	1.00 H	31	9.91	46.49
4	15600.00	63.4 PK	74.0	-10.6	1.23 H	180	15.55	47.85
5	15600.00	51.0 AV	54.0	-3.0	1.23 H	180	3.15	47.85

ANTENNA POLARITY & TEST DISTANCE: VERTICAL AT 3 M

NO.	FREQ. (MHz)	EMISSION LEVEL (dBuV/m)	LIMIT (dBuV/m)	MARGIN (dB)	ANTENNA HEIGHT (m)	TABLE ANGLE (Degree)	RAW VALUE (dBuV)	CORRECTION FACTOR (dB/m)
1	*5200.00	110.1 PK			1.25 V	44	73.31	36.79
2	*5200.00	100.8 AV			1.25 V	44	64.01	36.79
3	5400.00	62.3 PK	74.0	-11.7	1.29 V	44	25.28	37.02
4	5400.00	51.4 AV	54.0	-2.6	1.29 V	44	14.38	37.02
5	#10400.00	56.7 PK	68.3	-11.6	1.00 V	153	10.21	46.49
6	15600.00	63.5 PK	74.0	-10.5	1.00 V	232	15.65	47.85
7	15600.00	51.4 AV	54.0	-2.6	1.00 V	232	3.55	47.85

REMARKS:

1. Emission level (dBuV/m) = Raw Value (dBuV) + Correction Factor (dB/m).
2. Correction Factor (dB/m) = Antenna Factor (dB/m) + Cable Factor (dB).
3. The other emission levels were very low against the limit.
4. Margin value = Emission level – Limit value.
5. " * ": Fundamental frequency.
6. " # ": The radiated frequency is out of the restricted band.



A D T

CHANNEL	TX Channel 48	DETECTOR FUNCTION	Peak (PK)
FREQUENCY RANGE	1GHz ~ 40GHz		Average (AV)

ANTENNA POLARITY & TEST DISTANCE: HORIZONTAL AT 3 M

NO.	FREQ. (MHz)	EMISSION LEVEL (dBuV/m)	LIMIT (dBuV/m)	MARGIN (dB)	ANTENNA HEIGHT (m)	TABLE ANGLE (Degree)	RAW VALUE (dBuV)	CORRECTION FACTOR (dB/m)
1	*5240.00	101.5 PK			1.07 H	43	64.63	36.87
2	*5240.00	91.9 AV			1.07 H	43	55.03	36.87
3	#5250.00	67.2 PK	68.3	-1.1	1.07 H	31	30.32	36.88
4	5350.00	59.7 PK	74.0	-14.3	1.10 H	50	22.70	37.00
5	5350.00	47.3 AV	54.0	-6.7	1.10 H	50	10.30	37.00
6	#10480.00	56.7 PK	68.3	-11.6	1.01 H	33	10.26	46.44
7	15720.00	63.6 PK	74.0	-10.4	1.23 H	177	15.54	48.06
8	15720.00	51.2 AV	54.0	-2.8	1.23 H	177	3.14	48.06

ANTENNA POLARITY & TEST DISTANCE: VERTICAL AT 3 M

NO.	FREQ. (MHz)	EMISSION LEVEL (dBuV/m)	LIMIT (dBuV/m)	MARGIN (dB)	ANTENNA HEIGHT (m)	TABLE ANGLE (Degree)	RAW VALUE (dBuV)	CORRECTION FACTOR (dB/m)
1	*5240.00	109.3 PK			1.23 V	49	72.43	36.87
2	*5240.00	99.9 AV			1.23 V	49	63.03	36.87
3	#5250.00	67.3 PK	68.3	-1.0	1.24 V	60	30.42	36.88
4	5400.00	61.3 PK	74.0	-12.7	1.30 V	45	24.28	37.02
5	5400.00	51.6 AV	54.0	-2.4	1.30 V	45	14.58	37.02
6	#10480.00	56.6 PK	68.3	-11.7	1.00 V	151	10.16	46.44
7	15720.00	63.4 PK	74.0	-10.6	1.00 V	231	15.34	48.06
8	15720.00	51.3 AV	54.0	-2.7	1.00 V	231	3.24	48.06

REMARKS:

1. Emission level (dBuV/m) = Raw Value (dBuV) + Correction Factor (dB/m).
2. Correction Factor (dB/m) = Antenna Factor (dB/m) + Cable Factor (dB).
3. The other emission levels were very low against the limit.
4. Margin value = Emission level – Limit value.
5. " * ": Fundamental frequency.
6. " # ": The radiated frequency is out of the restricted band.



802.11n (40MHz)

CHANNEL	TX Channel 38	DETECTOR FUNCTION	Peak (PK)
FREQUENCY RANGE	1GHz ~ 40GHz		Average (AV)

ANTENNA POLARITY & TEST DISTANCE: HORIZONTAL AT 3 M

NO.	FREQ. (MHz)	EMISSION LEVEL (dBuV/m)	LIMIT (dBuV/m)	MARGIN (dB)	ANTENNA HEIGHT (m)	TABLE ANGLE (Degree)	RAW VALUE (dBuV)	CORRECTION FACTOR (dB/m)
1	5040.00	59.5 PK	74.0	-14.5	1.05 H	51	22.92	36.58
2	5040.00	49.1 AV	54.0	-4.9	1.05 H	51	12.52	36.58
3	*5190.00	100.3 PK			1.05 H	50	63.53	36.77
4	*5190.00	91.1 AV			1.05 H	50	54.33	36.77
5	#10380.00	56.5 PK	68.3	-11.8	1.00 H	41	10.07	46.43
6	15570.00	62.8 PK	74.0	-11.2	1.22 H	169	14.80	48.00
7	15570.00	50.3 AV	54.0	-3.7	1.22 H	169	2.30	48.00

ANTENNA POLARITY & TEST DISTANCE: VERTICAL AT 3 M

NO.	FREQ. (MHz)	EMISSION LEVEL (dBuV/m)	LIMIT (dBuV/m)	MARGIN (dB)	ANTENNA HEIGHT (m)	TABLE ANGLE (Degree)	RAW VALUE (dBuV)	CORRECTION FACTOR (dB/m)
1	5150.00	62.7 PK	74.0	-11.3	1.26 V	45	25.99	36.71
2	5150.00	51.9 AV	54.0	-2.1	1.26 V	45	15.19	36.71
3	*5190.00	108.7 PK			1.25 V	46	71.93	36.77
4	*5190.00	99.3 AV			1.25 V	46	62.53	36.77
5	5400.00	61.4 PK	74.0	-12.6	1.30 V	46	24.38	37.02
6	5400.00	51.9 AV	54.0	-2.1	1.30 V	46	14.88	37.02
7	#10380.00	56.3 PK	68.3	-12.0	1.00 V	153	9.87	46.43
8	15570.00	62.2 PK	74.0	-11.8	1.00 V	230	14.20	48.00
9	15570.00	50.1 AV	54.0	-3.9	1.00 V	230	2.10	48.00

REMARKS:

1. Emission level (dBuV/m) = Raw Value (dBuV) + Correction Factor (dB/m).
2. Correction Factor (dB/m) = Antenna Factor (dB/m) + Cable Factor (dB).
3. The other emission levels were very low against the limit.
4. Margin value = Emission level – Limit value.
5. " * ": Fundamental frequency.
6. " # ": The radiated frequency is out of the restricted band.



A D T

CHANNEL	TX Channel 46	DETECTOR FUNCTION	Peak (PK)
FREQUENCY RANGE	1GHz ~ 40GHz		Average (AV)

ANTENNA POLARITY & TEST DISTANCE: HORIZONTAL AT 3 M

NO.	FREQ. (MHz)	EMISSION LEVEL (dBuV/m)	LIMIT (dBuV/m)	MARGIN (dB)	ANTENNA HEIGHT (m)	TABLE ANGLE (Degree)	RAW VALUE (dBuV)	CORRECTION FACTOR (dB/m)
1	*5230.00	100.9 PK			1.08 H	41	64.05	36.85
2	*5230.00	90.7 AV			1.08 H	41	53.85	36.85
3	#5250.00	67.4 PK	68.3	-0.9	1.08 H	44	30.52	36.88
4	5350.00	59.1 PK	74.0	-14.9	1.08 H	44	22.10	37.00
5	5350.00	47.3 AV	54.0	-6.7	1.08 H	44	10.30	37.00
6	#10460.00	56.1 PK	68.3	-12.2	1.00 H	39	9.65	46.45
7	15690.00	62.5 PK	74.0	-11.5	1.20 H	164	14.46	48.04
8	15690.00	50.1 AV	54.0	-3.9	1.20 H	164	2.06	48.04

ANTENNA POLARITY & TEST DISTANCE: VERTICAL AT 3 M

NO.	FREQ. (MHz)	EMISSION LEVEL (dBuV/m)	LIMIT (dBuV/m)	MARGIN (dB)	ANTENNA HEIGHT (m)	TABLE ANGLE (Degree)	RAW VALUE (dBuV)	CORRECTION FACTOR (dB/m)
1	5120.00	59.0 PK	74.0	-15.0	1.26 V	45	22.34	36.66
2	5120.00	51.4 AV	54.0	-2.6	1.26 V	45	14.74	36.66
3	*5230.00	108.5 PK			1.23 V	43	71.65	36.85
4	*5230.00	99.6 AV			1.23 V	43	62.75	36.85
5	#5250.00	66.9 PK	68.3	-1.4	1.22 V	41	30.02	36.88
6	5400.00	61.6 PK	74.0	-12.4	1.17 V	45	24.58	37.02
7	5400.00	51.9 AV	54.0	-2.1	1.17 V	45	14.88	37.02
8	5440.00	60.4 PK	74.0	-13.6	1.26 V	60	23.32	37.08
9	5440.00	51.6 AV	54.0	-2.4	1.26 V	60	14.52	37.08
10	#10460.00	56.2 PK	68.3	-12.1	1.00 V	150	9.75	46.45
11	15690.00	63.1 PK	74.0	-10.9	1.00 V	231	15.06	48.04
12	15690.00	50.2 AV	54.0	-3.8	1.00 V	231	2.16	48.04

REMARKS:

1. Emission level (dBuV/m) = Raw Value (dBuV) + Correction Factor (dB/m).
2. Correction Factor (dB/m) = Antenna Factor (dB/m) + Cable Factor (dB).
3. The other emission levels were very low against the limit.
4. Margin value = Emission level – Limit value.
5. " * ": Fundamental frequency.
6. " # ": The radiated frequency is out of the restricted band.



A D T

4.3 TRANSMIT POWER MEASUREMENT

4.3.1 LIMITS OF TRANSMIT POWER MEASUREMENT

Frequency Band	Limit
5.15 – 5.25GHz	The lesser of 50mW (17dBm) or 4dBm + 10logB
5.25 – 5.35GHz	The lesser of 250mW (24dBm) or 11dBm + 10logB
5.47 – 5.725GHz	The lesser of 250mW (24dBm) or 11dBm + 10logB
5.725 – 5.825GHz	The lesser of 1W (30dBm) or 17dBm + 10logB

NOTE: Where B is the 26dB emission bandwidth in MHz.

4.3.2 TEST INSTRUMENTS

FOR POWER OUTPUT MEASUREMENT

DESCRIPTION & MANUFACTURER	MODEL NO.	SERIAL NO.	CALIBRATED DATE	CALIBRATED UNTIL
Peak Power Meter	ML2495A	0824006	May 04, 2011	May 03, 2012
Power Sensor	MA2411B	0738172	May 03, 2011	May 02, 2012

Note:

1. The calibration interval of the above test instruments is 12 months and the calibrations are traceable to NML/ROC and NIST/USA.
2. Tested date : Mar. 20, 2012

FOR 26dB OCCUPIED BANDWIDTH

DESCRIPTION & MANUFACTURER	MODEL NO.	SERIAL NO.	CALIBRATED DATE	CALIBRATED UNTIL
Spectrum Analyzer	E4446A	MY48250254	July 12, 2011	July 11, 2012

Note:

1. The calibration interval of the above test instruments is 12 months and the calibrations are traceable to NML/ROC and NIST/USA.
2. Tested date : Mar. 20, 2012

4.3.3 TEST PROCEDURE

FOR POWER OUTPUT MEASUREMENT

An average power sensor was used on the output port of the EUT. A power meter was used to read the response of the average power sensor. Record the power level.

FOR 26dB OCCUPIED BANDWIDTH

- 1) Set RBW = approximately 1% of the emission bandwidth.
- 2) Set the VBW > RBW.
- 3) Detector = Peak.
- 4) Trace mode = max hold.
- 5) Measure the maximum width of the emission that is 26 dB down from the peak of the emission. Compare this with the RBW setting of the analyzer. Readjust RBW and repeat measurement as needed until the RBW/EBW ratio is approximately 1%.

4.3.4 DEVIATION FROM TEST STANDARD

No deviation

4.3.5 TEST SETUP

FOR POWER OUTPUT MEASUREMENT

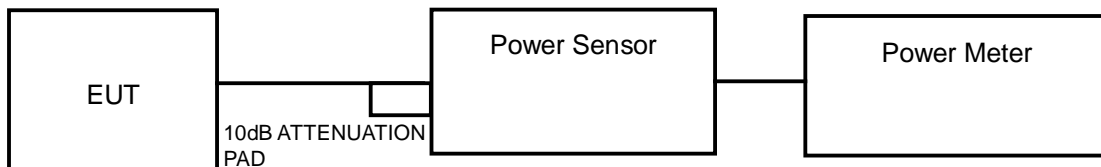

FOR 26dB OCCUPIED BANDWIDTH

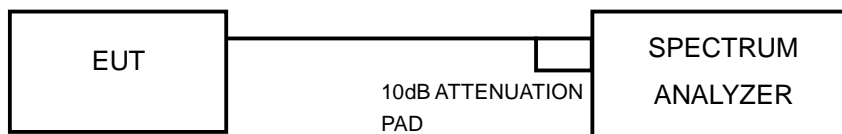

4.3.6 EUT OPERATING CONDITIONS

The software provided by client to enable the EUT under transmission condition continuously at specific channel frequencies individually.

4.3.7 TEST RESULTS

POWER OUTPUT:

802.11a

CHAN.	CHAN. FREQ. (MHz)	AVERAGE POWER (dBm)			TOTAL POWER (mW)	TOTAL POWER (dBm)	POWER LIMIT (dBm)	PASS / FAIL
		CHAIN 0	CHAIN 1	CHAIN 2				
36	5180	6.30	6.00	7.50	13.87	11.42	16.23	PASS
40	5200	6.10	6.20	7.10	13.372	11.26	16.23	PASS
48	5240	5.80	6.50	6.30	12.535	10.98	16.23	PASS

Note: Directional gain = gain of antenna element + 10 log (# of TX antenna elements)

Effective Legacy Gain (dBi) = 6.77

The effective legacy gain is 6.77dBi, therefore the limit needs to reduce.

802.11n (20MHz)

CHAN.	CHAN. FREQ. (MHz)	AVERAGE POWER (dBm)			TOTAL POWER (mW)	TOTAL POWER (dBm)	POWER LIMIT (dBm)	PASS / FAIL
		CHAIN 0	CHAIN 1	CHAIN 2				
36	5180	6.00	5.90	7.30	13.241	11.22	17.00	PASS
40	5200	6.20	6.00	6.80	12.936	11.12	17.00	PASS
48	5240	5.60	6.10	6.10	11.779	10.71	17.00	PASS

802.11n (40MHz)

CHAN.	CHAN. FREQ. (MHz)	AVERAGE POWER (dBm)			TOTAL POWER (mW)	TOTAL POWER (dBm)	POWER LIMIT (dBm)	PASS / FAIL
		CHAIN 0	CHAIN 1	CHAIN 2				
38	5190	6.70	6.20	8.10	15.303	11.85	17.00	PASS
46	5230	6.50	6.80	7.60	15.007	11.76	17.00	PASS



A D T

26dB BANDWIDTH:

802.11a

CHANNEL	CHANNEL FREQUENCY (MHz)	26dBc BANDWIDTH (MHz)		
		CHAIN 0	CHAIN 1	CHAIN 2
36	5180	22.82	22.51	22.46
40	5200	22.76	22.45	22.44
48	5240	22.83	22.67	22.43

802.11n (20MHz)

CHANNEL	CHANNEL FREQUENCY (MHz)	26dBc BANDWIDTH (MHz)		
		CHAIN 0	CHAIN 1	CHAIN 2
36	5180	23.17	23.18	23.09
40	5200	23.21	23.91	24.23
48	5240	23.79	23.24	24.56

802.11n (40MHz)

CHANNEL	CHANNEL FREQUENCY (MHz)	26dBc BANDWIDTH (MHz)		
		CHAIN 0	CHAIN 1	CHAIN 2
38	5190	49.25	47.50	47.98
46	5230	49.24	50.01	47.30

4.4 OCCUPIED BANDWIDTH MEASUREMENT

4.4.1 TEST INSTRUMENTS

DESCRIPTION & MANUFACTURER	MODEL NO.	SERIAL NO.	CALIBRATED DATE	CALIBRATED UNTIL
R&S Spectrum Analyzer	FSP 40	100060	May 11, 2011	May 10, 2012

Note:

1. The calibration interval of the above test instruments is 12 months and the calibrations are traceable to NML/ROC and NIST/USA.
2. Tested date : Mar. 20, 2012

4.4.2 TEST PROCEDURE

- 1) Set RBW \geq 1% of the emission bandwidth.
- 2) Set the VBW \geq 3 x RBW.
- 3) Detector = Peak.
- 4) Trace mode = max hold.
- 5) Record the 99% emission bandwidth.

4.4.3 DEVIATION FROM TEST STANDARD

No deviation

4.4.4 TEST SETUP

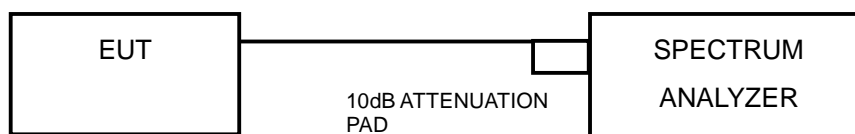

4.4.5 EUT OPERATING CONDITIONS

The software provided by client to enable the EUT under transmission condition continuously at lowest, middle and highest channel frequencies individually.



A D T

4.4.6 TEST RESULTS

802.11a

CHANNEL	CHANNEL FREQUENCY (MHz)	OCCUPIED BANDWIDTH (MHz)			PASS / FAIL
		CHAIN 0	CHAIN 1	CHAIN 2	
36	5180	16.80	16.80	16.70	PASS
40	5200	16.70	16.70	16.70	PASS
48	5240	16.80	16.70	16.80	PASS

802.11n (20MHz)

CHANNEL	CHANNEL FREQUENCY (MHz)	OCCUPIED BANDWIDTH (MHz)			PASS / FAIL
		CHAIN 0	CHAIN 1	CHAIN 2	
36	5180	17.80	17.90	17.90	PASS
40	5200	17.80	17.80	17.90	PASS
48	5240	18.00	17.80	18.00	PASS

802.11n (40MHz)

CHANNEL	CHANNEL FREQUENCY (MHz)	OCCUPIED BANDWIDTH (MHz)			PASS / FAIL
		CHAIN 0	CHAIN 1	CHAIN 2	
38	5190	36.80	36.60	36.80	PASS
46	5230	37.00	36.80	36.60	PASS

4.5 PEAK POWER SPECTRAL DENSITY MEASUREMENT

4.5.1 LIMITS OF PEAK POWER SPECTRAL DENSITY MEASUREMENT

Frequency Band	Limit
5.15 ~ 5.25GHz	4dBm
5.25 ~ 5.35GHz	11dBm
5.47 – 5.725GHz	11dBm
5.725 ~ 5.825GHz	17dBm

4.5.2 TEST INSTRUMENTS

DESCRIPTION & MANUFACTURER	MODEL NO.	SERIAL NO.	CALIBRATED DATE	CALIBRATED UNTIL
Spectrum Analyzer	E4446A	MY48250254	July 12, 2011	July 11, 2012

Note:

1. The calibration interval of the above test instruments is 12 months and the calibrations are traceable to NML/ROC and NIST/USA.
2. Tested date : Mar. 20, 2012

4.5.3 TEST PROCEDURES

- 1) Set span to encompass the entire emission bandwidth (EBW) of the signal.
- 2) Set RBW = 1 MHz, Set VBW \geq 3 MHz, Detector = RMS
- 3) Sweep time = auto, trigger set to “free run”.
- 4) Trace average at least 100 traces in power averaging mode.
- 5) Record the max value

4.5.4 DEVIATION FROM TEST STANDARD

No deviation

4.5.5 TEST SETUP

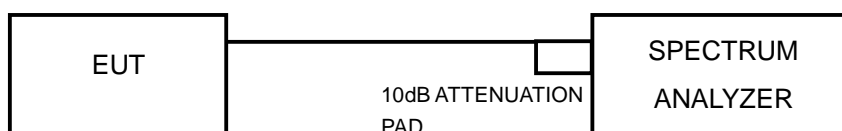

4.5.6 EUT OPERATING CONDITIONS

Same as 4.3.6

4.5.7 TEST RESULTS

802.11a

CHAN.	CHAN. FREQ. (MHz)	PSD (dBm)			TOTAL POWER DENSITY (dBm)	MAX. LIMIT (dBm)	PASS / FAIL
		CHAIN 0	CHAIN 1	CHAIN 2			
36	5180	-4.09	-5.15	-3.22	0.21	3.23	PASS
40	5200	-4.33	-5.40	-3.80	-0.11	3.23	PASS
48	5240	-4.49	-4.70	-4.74	-0.27	3.23	PASS

- NOTE:** 1. Method 1 of power density measurement of KDB 662911 is using for calculating total power density. Total power density is summing entire spectra across corresponding frequency bins on the various outputs by computer.
2. Directional gain = gain of antenna element + 10 log (# of TX antenna elements)
 Effective Legacy Gain (dBi) = 6.77
 The effective legacy gain is 6.77dBi, therefore the limit needs to reduce.

802.11n (20MHz)

CHAN.	CHAN. FREQ. (MHz)	PSD (dBm)			TOTAL POWER DENSITY (dBm)	MAX. LIMIT (dBm)	PASS / FAIL
		CHAIN 0	CHAIN 1	CHAIN 2			
36	5180	-4.41	-4.61	-3.81	-0.13	4	PASS
40	5200	-4.45	-4.77	-4.37	-0.34	4	PASS
48	5240	-5.08	-5.42	-5.38	-0.77	4	PASS

- NOTE:** Method 1 of power density measurement of KDB 662911 is using for calculating total power density. Total power density is summing entire spectra across corresponding frequency bins on the various outputs by computer.

802.11n (40MHz)

CHAN.	CHAN. FREQ. (MHz)	PSD (dBm)			TOTAL POWER DENSITY (dBm)	MAX. LIMIT (dBm)	PASS / FAIL
		CHAIN 0	CHAIN 1	CHAIN 2			
38	5190	-6.31	-7.54	-6.13	-2.01	4	PASS
46	5230	-7.20	-7.95	-6.28	-2.87	4	PASS

- NOTE:** Method 1 of power density measurement of KDB 662911 is using for calculating total power density. Total power density is summing entire spectra across corresponding frequency bins on the various outputs by computer.

4.6 PEAK POWER EXCURSION MEASUREMENT

4.6.1 LIMITS OF PEAK POWER EXCURSION MEASUREMENT

Shall not exceed 13 dB

4.6.2 TEST INSTRUMENTS

DESCRIPTION & MANUFACTURER	MODEL NO.	SERIAL NO.	CALIBRATED DATE	CALIBRATED UNTIL
Spectrum Analyzer	E4446A	MY48250254	July 12, 2011	July 11, 2012

Note:

1. The calibration interval of the above test instruments is 12 months and the calibrations are traceable to NML/ROC and NIST/USA.
2. Tested date : Mar. 20, 2012

4.6.3 TEST PROCEDURE

- 1) Set RBW = 1 MHz, VBW \leq 3 MHz, Detector = peak.
- 2) Trace mode = max-hold. Allow the sweeps to continue until the trace stabilizes.
- 3) Use the peak search function to find the peak of the spectrum.
- 4) Measure the PPSD.
- 5) Compute the ratio of the maximum of the peak-max-hold spectrum to the PPSD.

4.6.4 DEVIATION FROM TEST STANDARD

No deviation

4.6.5 TEST SETUP

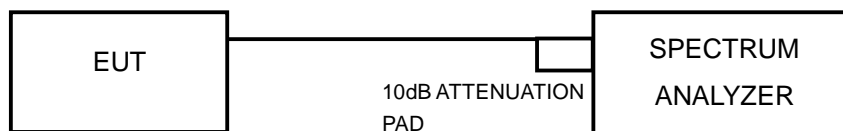

4.6.6 EUT OPERATING CONDITIONS

The software provided by client to enable the EUT under transmission condition continuously at specific channel frequencies individually.



A D T

4.6.7 TEST RESULTS

802.11a

TX chain	CHAN.	CHANNEL FREQUENCY (MHz)	PEAK VALUE (dBm)	PPSD (dBm)	PEAK EXCURSION (dB)	LIMIT (dB)	PASS /FAIL
0	36	5180	4.34	-4.09	8.43	13	PASS
	40	5200	4.40	-4.33	8.73	13	PASS
	48	5240	4.23	-4.49	8.72	13	PASS
1	36	5180	4.67	-5.15	9.82	13	PASS
	40	5200	4.60	-5.40	10.00	13	PASS
	48	5240	4.94	-4.70	9.64	13	PASS
2	36	5180	6.90	-3.22	10.12	13	PASS
	40	5200	6.46	-3.80	10.26	13	PASS
	48	5240	5.46	-4.74	10.20	13	PASS



A D T

Chain 0: CH 40

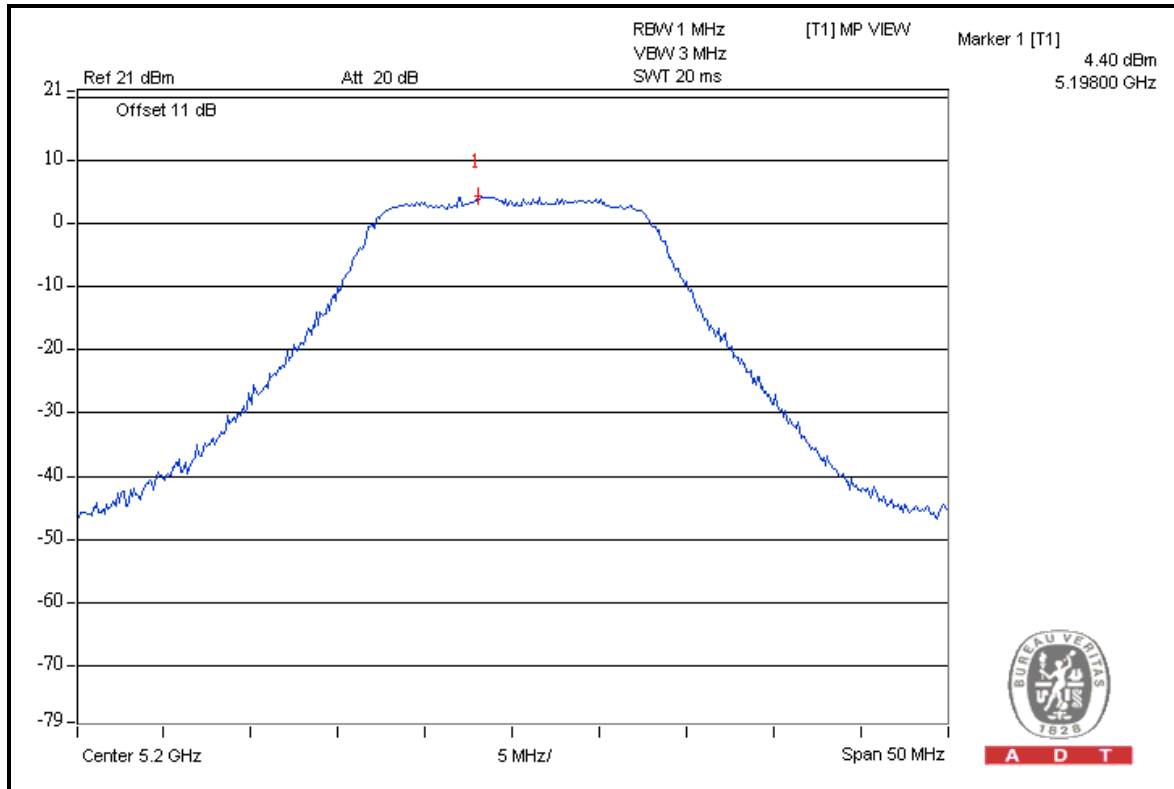

Chain 1: CH 48

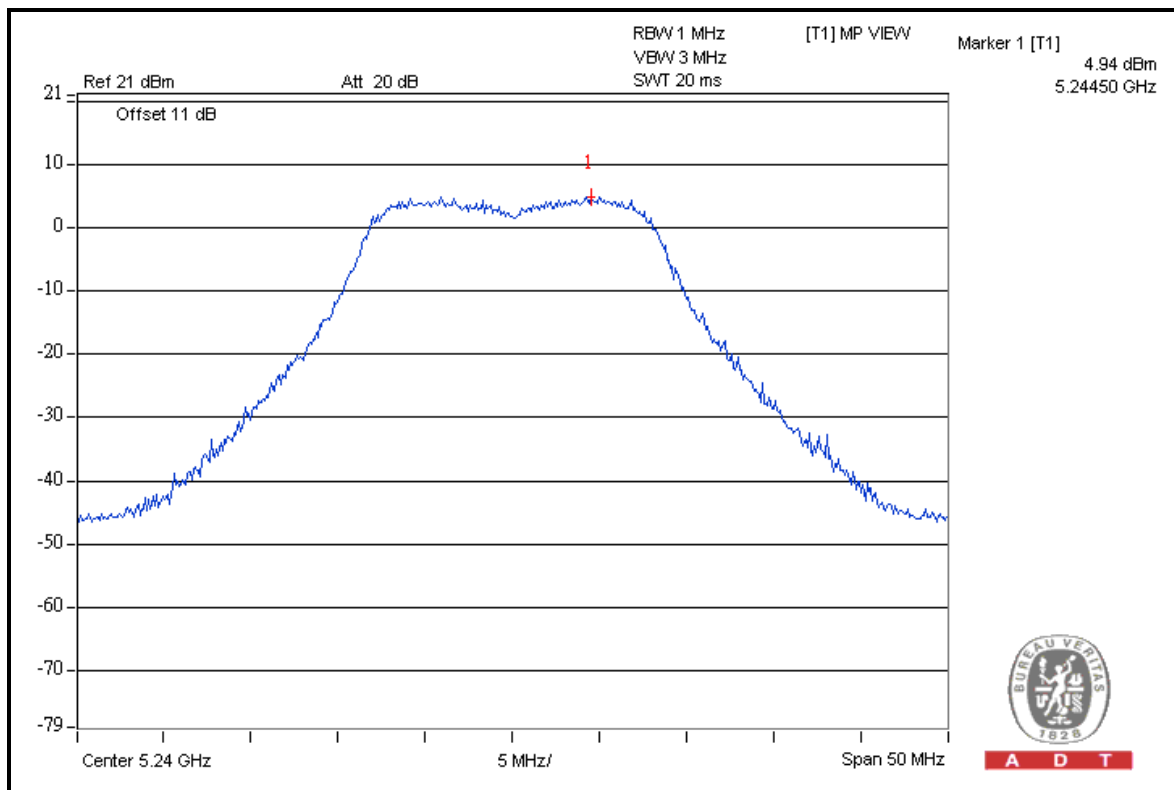



A D T

Chain 2: CH 36

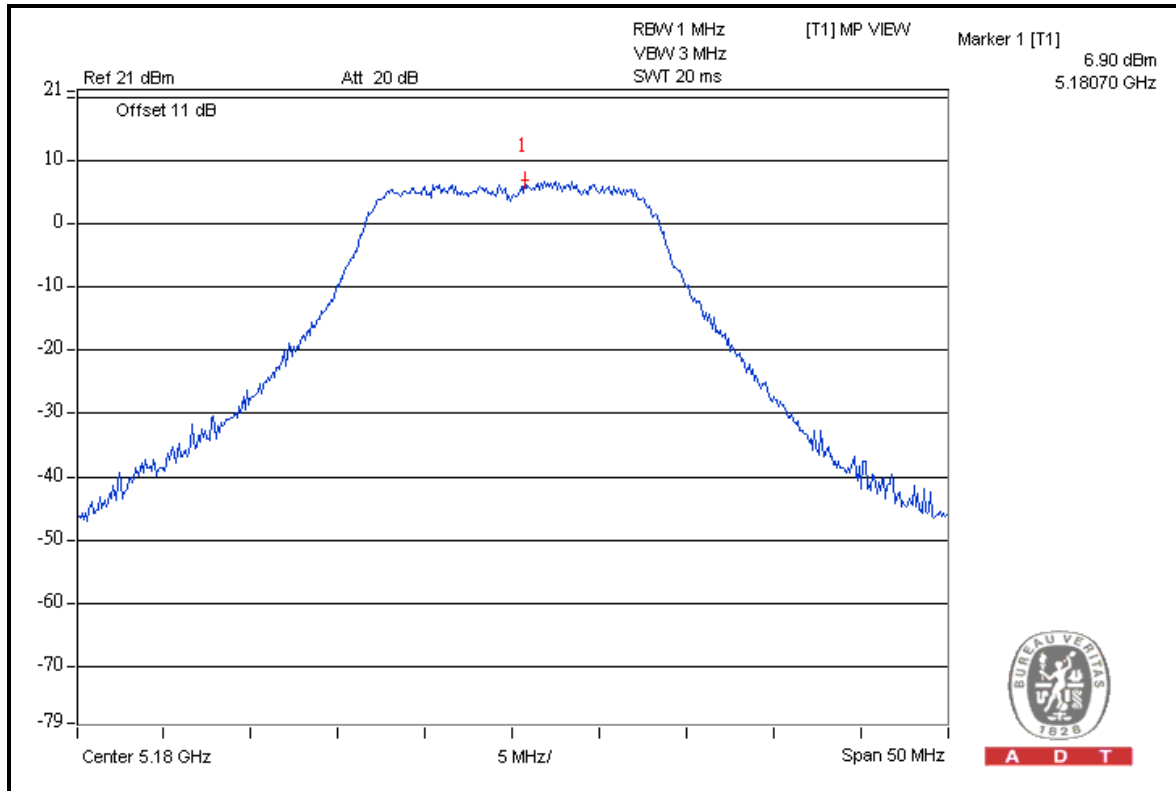



A D T

802.11n (20MHz)

TX chain	CHAN.	CHANNEL FREQUENCY (MHz)	PEAK VALUE (dBm)	PPSD (dBm)	PEAK EXCURSION (dB)	LIMIT (dB)	PASS /FAIL
0	36	5180	4.80	-4.41	9.21	13	PASS
	40	5200	4.65	-4.45	9.10	13	PASS
	48	5240	4.52	-5.08	9.60	13	PASS
1	36	5180	4.89	-4.61	9.50	13	PASS
	40	5200	4.78	-4.77	9.55	13	PASS
	48	5240	4.15	-5.42	9.57	13	PASS
2	36	5180	6.73	-3.81	10.54	13	PASS
	40	5200	5.64	-4.37	10.01	13	PASS
	48	5240	4.97	-5.38	10.35	13	PASS



A D T

Chain 0: CH 36

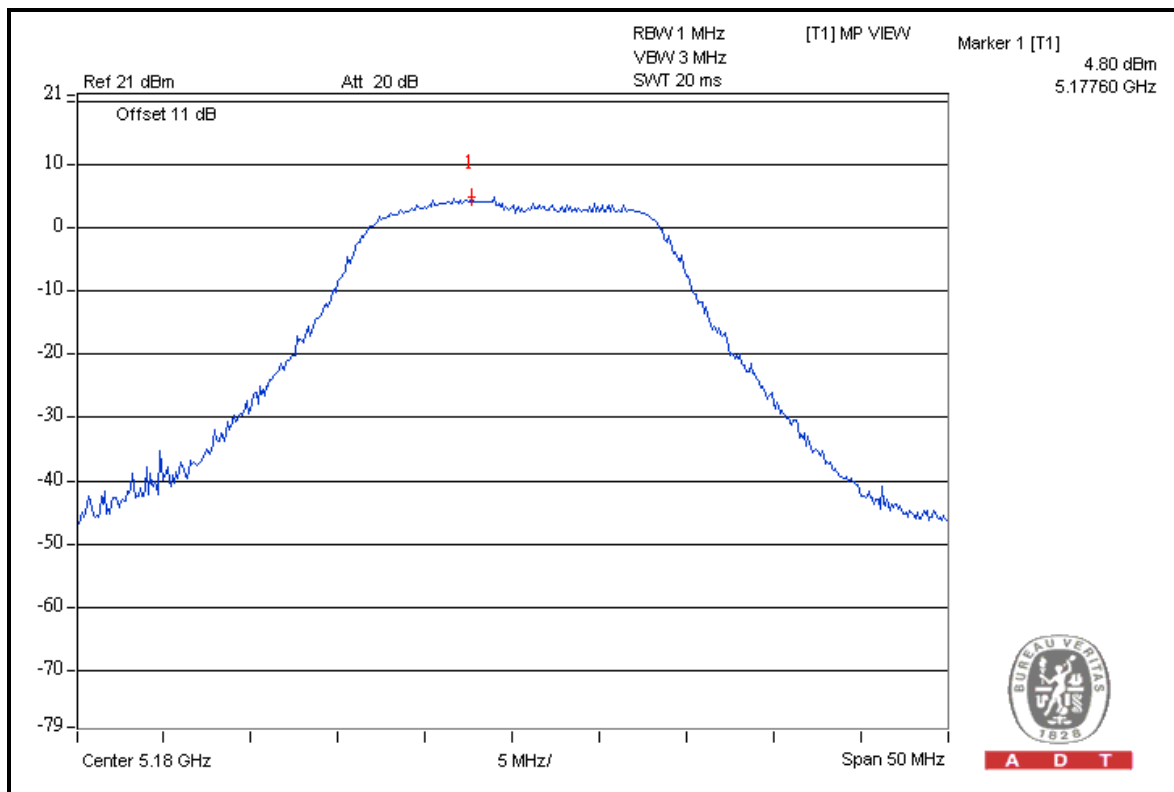

Chain 1: CH 36

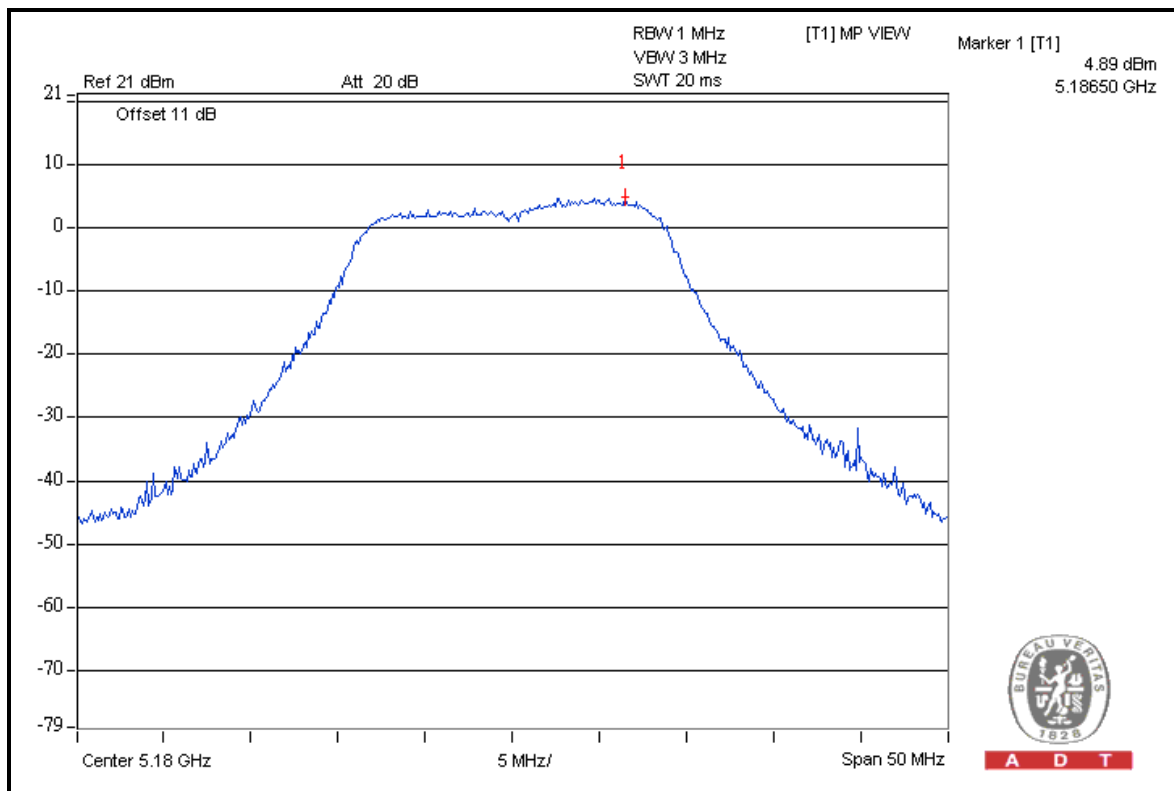



A D T

Chain 2 CH 36

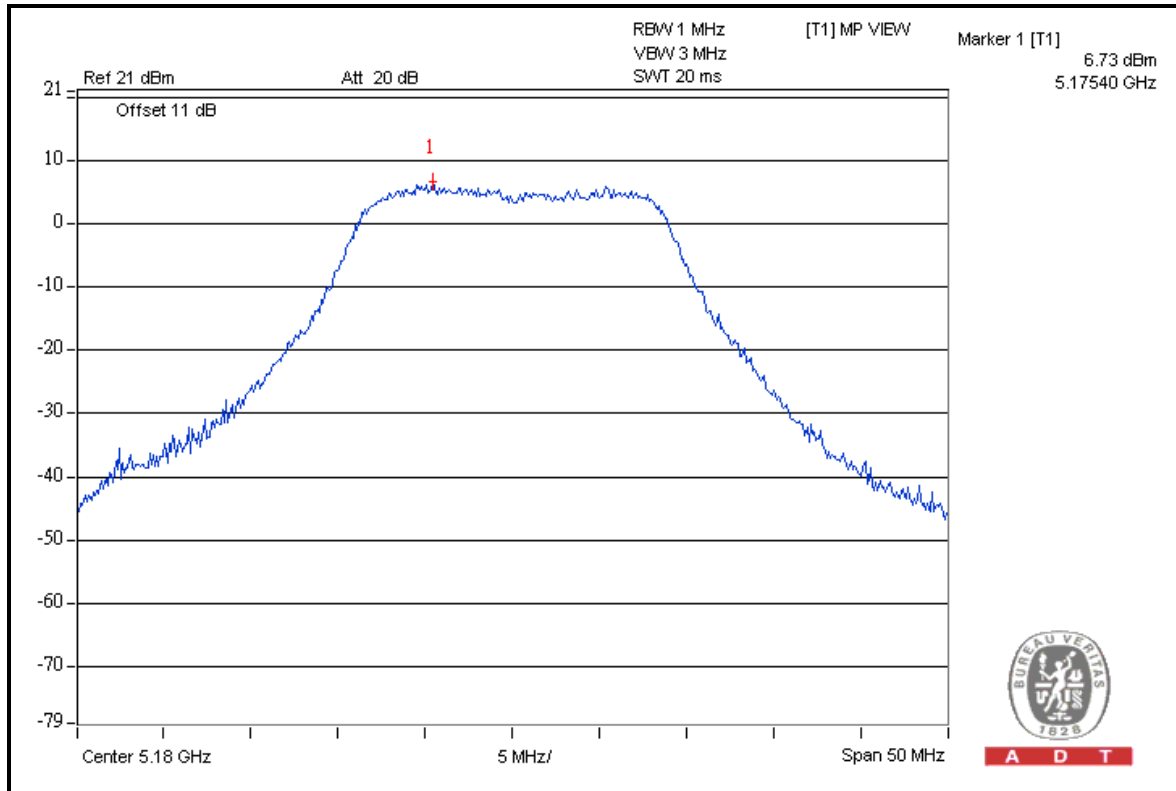



A D T

802.11n (40MHz)

TX chain	CHAN.	CHANNEL FREQUENCY (MHz)	PEAK VALUE (dBm)	PPSD (dBm)	PEAK EXCURSION (dB)	LIMIT (dB)	PASS /FAIL
0	38	5190	3.35	-6.31	9.66	13	PASS
	46	5230	1.99	-7.20	9.19	13	PASS
1	38	5190	1.94	-7.54	9.48	13	PASS
	46	5230	2.49	-7.95	10.44	13	PASS
2	38	5190	4.16	-6.13	10.29	13	PASS
	46	5230	3.85	-6.28	10.13	13	PASS



A D T

Chain 0: CH 38

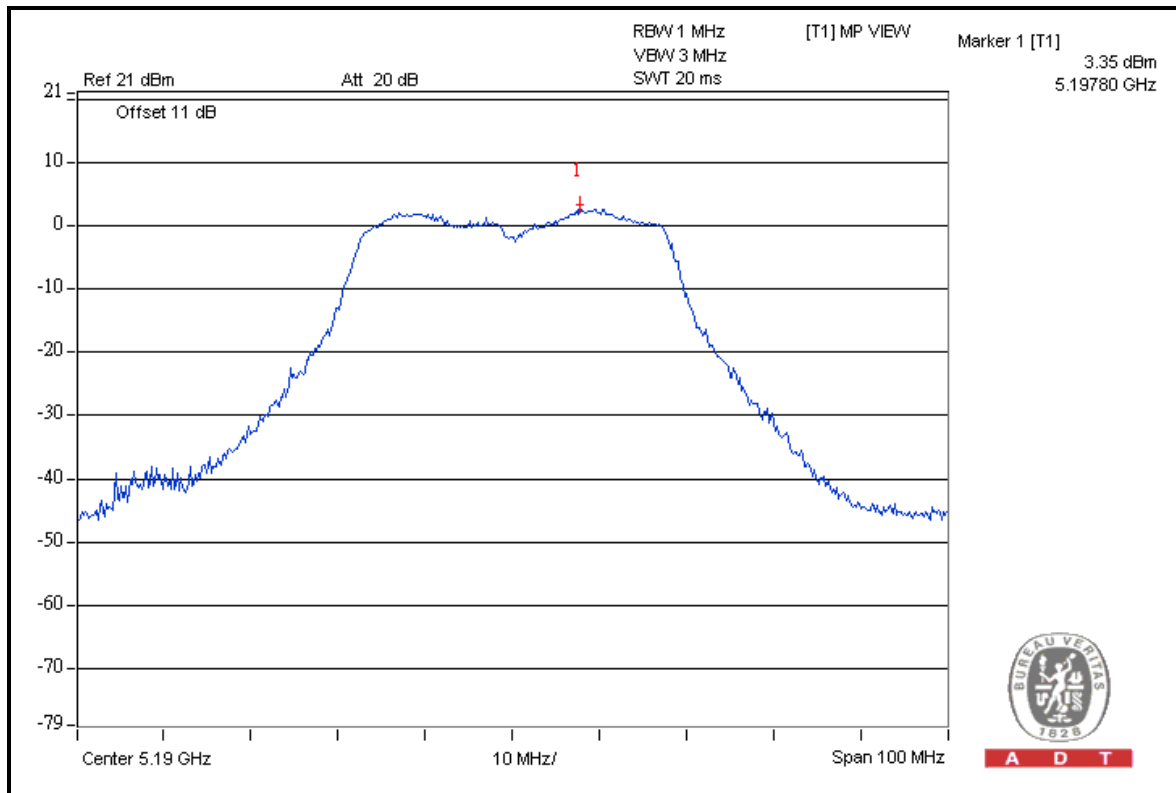

Chain 1: CH 46

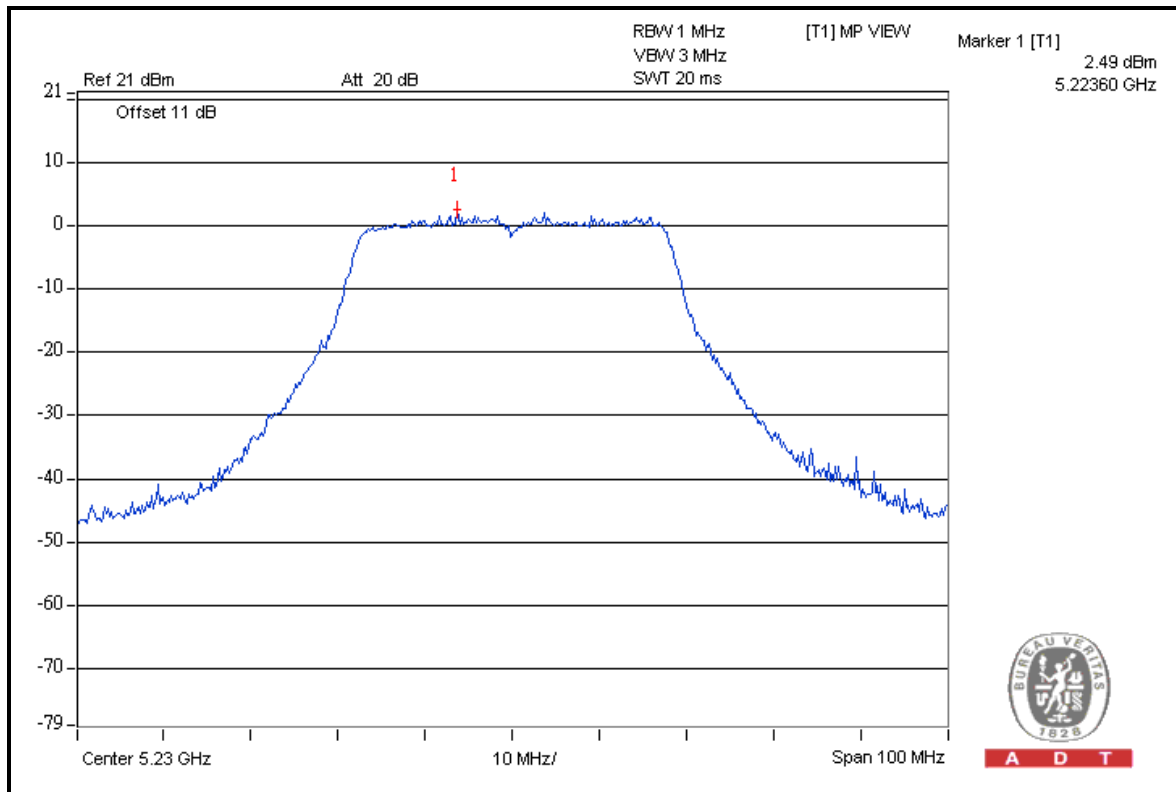



A D T

Chain 2 CH 38

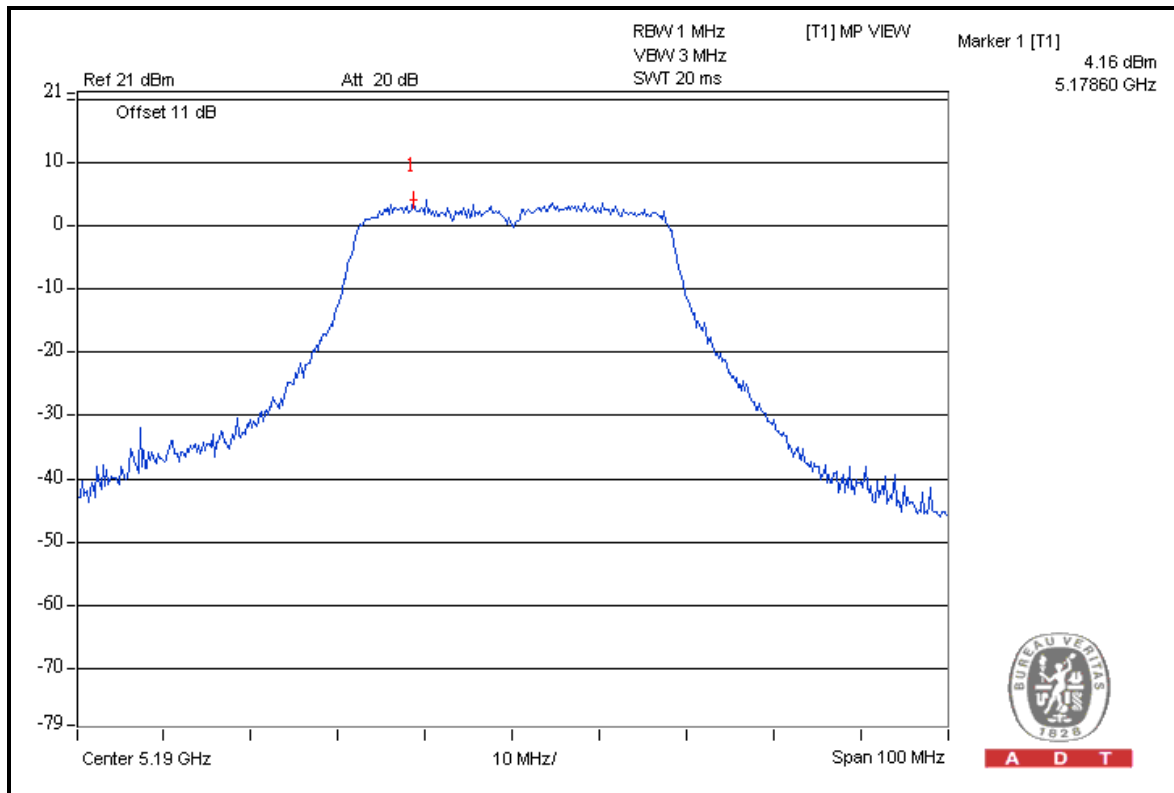

4.7 FREQUENCY STABILITY

4.7.1 LIMITS OF FREQUENCY STABILITY MEASUREMENT

The frequency of the carrier signal shall be maintained within band of operation

4.7.2 TEST INSTRUMENTS

DESCRIPTION & MANUFACTURER	MODEL NO.	SERIAL NO.	CALIBRATED DATE	CALIBRATED UNTIL
R&S Spectrum Analyzer	FSP 40	100060	May 11, 2011	May 10, 2012

Note:

1. The calibration interval of the above test instruments is 12 months and the calibrations are traceable to NML/ROC and NIST/USA.
2. Tested date : Mar. 20, 2012

4.7.3 TEST PROCEDURE

1. The EUT was placed inside the environmental test chamber and powered by nominal AC voltage.
2. Turn the EUT on and couple its output to a spectrum analyzer.
3. Turn the EUT off and set the chamber to the highest temperature specified.
4. Allow sufficient time (approximately 30 min) for the temperature of the chamber to stabilize, turn the EUT on and measure the operating frequency after 2, 5, and 10 minutes.
5. Repeat step 2 and 3 with the temperature chamber set to the lowest temperature.
6. The test chamber was allowed to stabilize at +20 degree C for a minimum of 30 minutes. The supply voltage was then adjusted on the EUT from 85% to 115% and the frequency record.

4.7.4 DEVIATION FROM TEST STANDARD

No deviation

4.7.5 TEST SETUP

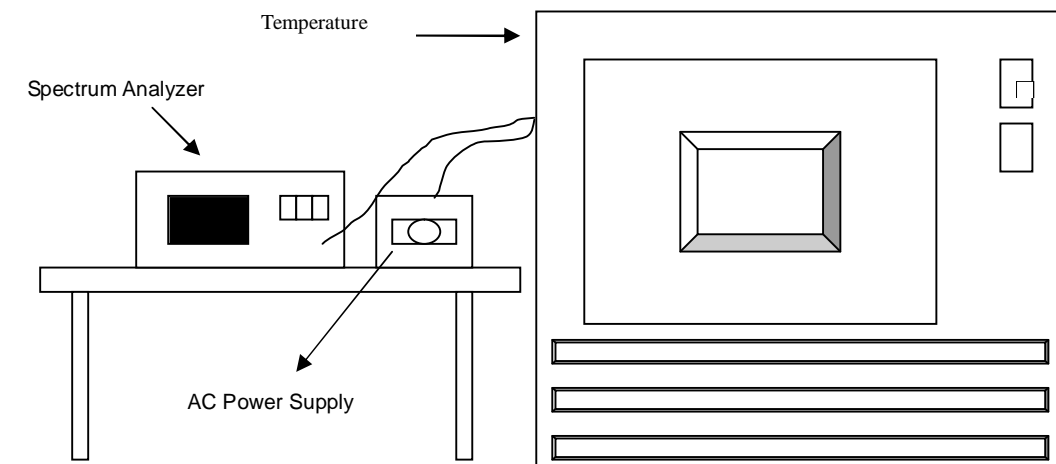

4.7.6 EUT OPERATING CONDITION

Set the EUT transmit at un-modulation mode to test frequency stability.



A D T

4.7.7 TEST RESULTS

FREQUENCY STABILITY VERSUS TEMP.									
OPERATING FREQUENCY: 5240MHz									
TEMP. (°C)	POWER SUPPLY (Vac)	0 MINUTE		2 MINUTE		5 MINUTE		10 MINUTE	
		Measured Frequency	Frequency Drift	Measured Frequency	Frequency Drift	Measured Frequency	Frequency Drift	Measured Frequency	Frequency Drift
		(MHz)	ppm	(MHz)	ppm	(MHz)	ppm	(MHz)	ppm
50	120	5239.9886	-2.1756	5239.9928	-1.3740	5239.9913	-1.6603	5239.996	-0.7634
40	120	5240.0136	2.5954	5240.0123	2.3473	5240.0115	2.1947	5240.0094	1.7939
30	120	5239.9884	-2.2137	5239.9833	-3.1870	5239.9874	-2.4046	5239.9872	-2.4427
20	120	5239.9827	-3.3015	5239.9873	-2.4237	5239.9889	-2.1183	5239.9891	-2.0802
10	120	5239.985	-2.8626	5239.9855	-2.7672	5239.98	-3.8168	5239.9771	-4.3702
0	120	5239.9881	-2.2710	5239.9874	-2.4046	5239.9938	-1.1832	5239.9938	-1.1832
-10	120	5239.9986	-0.2672	5240.003	0.5725	5239.9999	-0.0191	5240.0027	0.5153
-20	120	5240.0113	2.1565	5240.0068	1.2977	5240.0119	2.2710	5240.0098	1.8702
-30	120	5240.0027	0.5153	5239.9983	-0.3244	5239.9989	-0.2099	5239.9973	-0.5153

FREQUENCY STABILITY VERSUS VOLTAGE									
OPERATING FREQUENCY: 5240MHz									
TEMP. (°C)	POWER SUPPLY (Vac)	0 MINUTE		2 MINUTE		5 MINUTE		10 MINUTE	
		Measured Frequency	Frequency Drift	Measured Frequency	Frequency Drift	Measured Frequency	Frequency Drift	Measured Frequency	Frequency Drift
		(MHz)	ppm	(MHz)	ppm	(MHz)	ppm	(MHz)	ppm
20	138	5239.983	-3.2443	5239.9865	-2.5763	5239.9884	-2.2137	5239.9878	-2.3282
	120	5239.9827	-3.3015	5239.9873	-2.4237	5239.9889	-2.1183	5239.9891	-2.0802
	102	5239.9833	-3.1870	5239.9865	-2.5763	5239.9891	-2.0802	5239.9884	-2.2137



A D T

5. PHOTOGRAPHS OF THE TEST CONFIGURATION

Please refer to the attached file (Test Setup Photo).





6. INFORMATION ON THE TESTING LABORATORIES

We, Bureau Veritas Consumer Products Services (H.K.) Ltd., Taoyuan Branch, were founded in 1988 to provide our best service in EMC, Radio, Telecom and Safety consultation. Our laboratories are accredited and approved according to ISO/IEC 17025.

Copies of accreditation and authorization certificates of our laboratories obtained from approval agencies can be downloaded from our web site:

www.adt.com.tw/index.5.phtml.

If you have any comments, please feel free to contact us at the following:

Linko EMC/RF Lab:

Tel: 886-2-26052180

Fax: 886-2-26052943

Hsin Chu EMC/RF Lab:

Tel: 886-3-5935343

Fax: 886-3-5935342

Hwa Ya EMC/RF/Safety/Telecom Lab:

Tel: 886-3-3183232

Fax: 886-3-3185050

Email: service.adt@tw.bureauveritas.com

Web Site: www.adt.com.tw

The address and road map of all our labs can be found in our web site also.



A D T

7.APPENDIX A - MODIFICATIONS RECORDERS FOR ENGINEERING CHANGES TO THE EUT BY THE LAB

No modifications were made to the EUT by the lab during the test.

--- END ---