

APPLICATION FOR CERTIFICATION
On Behalf of

TP-LINK Technologies Co., Ltd

108M Wireless ADSL2 + Router

Model Number: TD-W8920G

Prepared for : TP-LINK Technologies Co., Ltd
Building 7, Second Part, Honghualing Industrial Zone,
Xili town, Nanshan District, Shenzhen, China

Prepared By : Audix Technology (Shenzhen) Co., Ltd.
No. 6, Ke Feng Rd., 52 Block,
Shenzhen Science & Industrial Park,
Nantou, Shenzhen, Guangdong, China

Tel: (0755) 26639496

Report Number : ACS-F07354
Date of Test : Jul. 07 ~ 17, 2007
Date of Report : Aug. 20, 2007

TABLE OF CONTENTS

Description	Page
FCC Test Report for Declaration of Conformity	
1. SUMMARY OF STANDARDS AND RESULTS.....	1-1
1.1. Description of Standards and Results	1-1
2. GENERAL INFORMATION	2-1
2.1. Description of Device (EUT).....	2-1
2.2. Tested Supporting System Details	2-2
2.3. Test Facility	2-5
2.4. Measurement Uncertainty	2-5
3. POWER LINE CONDUCTED EMISSION TEST	3-1
3.1. Test Equipments.....	3-1
3.2. Block Diagram of Test Setup.....	3-1
3.3. Power Line Conducted Emission Test Limits.....	3-1
3.4. Configuration of EUT on Test	3-2
3.5. Operating Condition of EUT.....	3-2
3.6. Test Procedure.....	3-2
3.7. Power Line Conducted Emission Test Results	3-2
4. RADIATED EMISSION TEST	4-1
4.1. Test Equipment	4-1
4.2. Block Diagram of Test Setup.....	4-1
4.3. Radiated Emission Limit.....	4-2
4.4. EUT Configuration on Test.....	4-2
4.5. Operating Condition of EUT.....	4-3
4.6. Test Procedure.....	4-3
4.7. Radiated Emission Test Results	4-3
5. 6dB Bandwidth Test.....	5-1
5.1. Test Equipment	5-1
5.2. Test Information	5-1
5.3. Test Procedure.....	5-1
5.4. Test Results	5-2
6. OUTPUT POWER TEST.....	6-1
6.1. Test Equipment	6-1
6.2. Test Information	6-1
6.3. Test Procedure.....	6-1
6.4. Test Results	6-2
7. BAND EDGE COMPLIANCE TEST	7-3
7.1. Test Equipment	7-3
7.2. Test Information	7-3
7.3. Test Results	7-3
8. POWER SPECTRAL DENSITY TEST	8-1
8.1. Test Equipment	8-1
8.2. Test Information	8-1
8.3. Test Procedure.....	8-1
8.4. Test Results	8-2
9. MPE ESTIMATION.....	9-1
9.1. Limit for General Population / Uncontrolled Exposures	9-1
9.2. Estimation Result	9-1

- 10. ANTENNA REQUIREMENT 10-1**
- 11. DEVIATION TO TEST SPECIFICATIONS..... 11-1**
- 12. PHOTOGRAPH..... 12-1**
 - 12.1. Photos of Power Line Conducted Emission Test..... 12-1
 - 12.2. Photos of Radiated Emission Test..... 12-2

TEST REPORT CERTIFICATION

Applicant : TP-LINK Technologies Co., Ltd
Manufacturer : TP-LINK Technologies Co., Ltd
EUT Description : 108M Wireless ADSL2 + Router
(A) MODEL NO. : TD-W8920G
(B) SERIAL NO. : N/A
(C) POWER SUPPLY : DC 12V From Adapter AC 120V/60Hz

Test Procedure Used:

FCC Rules and Regulations Part 15 Subpart C 2006

The device described above is tested by AUDIX TECHNOLOGY (SHENZHEN) CO., LTD. to determine the maximum emission levels emanating from the device. The maximum emission levels are compared to the FCC Part 15 Subpart C limits both radiated and conducted emissions.

The test results are contained in this test report and AUDIX TECHNOLOGY (SHENZHEN) CO., LTD. is assumed full responsibility for the accuracy and completeness of these tests. Also, this report shows that the Equipment Under Test (EUT) is to be technically compliant with the FCC requirements.

This report applies to above tested sample only. This report shall not be reproduced in part without written approval of AUDIX TECHNOLOGY (SHENZHEN) CO., LTD.

Date of Test : Jul. 07 ~ 17, 2007

Prepared by : YoYo Wang / Assistant

Reviewer : Iceman Hu / Supervisor

Approved & Authorized Signer : Ken Lu / Deputy Manager

1. SUMMARY OF STANDARDS AND RESULTS

1.1. Description of Standards and Results

The EUT have been tested according to the applicable standards as referenced below.

EMISSION		
Description of Test Item	Standard	Results
Conducted Emission Test	FCC Part 15: 15.207 ANSI C63.4: 2003	PASS
Radiated Emission Test	FCC Part 15: 15.209 ANSI C63.4: 2003	PASS
6dB Bandwidth Test	FCC Part 15: 15.247	PASS
Output Power Test	FCC Part 15: 15.247	PASS
Band Edge Compliance Test	FCC Part 15: 15.247	PASS
Power Spectral Density Test	FCC Part 15: 15.247	PASS
MPE ESTIMATION	FCC Part 2: 2.1093	PASS
Antenna requirement	FCC Part 15: 15.203	PASS

2. GENERAL INFORMATION

2.1. Description of Device (EUT)

Product name	:	108M Wireless ADSL2 + Router
Model Number	:	TD-W8920G
Operation frequency	:	2.412GHz-----2.462GHz ISM Band
Channel Number	:	11
Channel frequency	:	$F = 2412 + 5(K-1)$ K=1,2,.....11
Radio Technology	:	IEEE 802.11b/g
Modulation Technology	:	DSSS for IEEE 802.11b and OFDM for IEEE802.11g
Output power	:	23.66dBm(measured)
Power	:	DC 12V from adapter 120V/60Hz
Antenna Assembly Gain	:	3dBi (maximum)
Applicant	:	TP-LINK Technologies Co., Ltd Building 7, Second Part, Honghualing Industrial Zone, Xili town, Nanshan District, Shenzhen, China
Manufacturer	:	TP-LINK Technologies Co., Ltd Building 7, Second Part, Honghualing Industrial Zone, Xili town, Nanshan District, Shenzhen, China
Power Adapter	:	Manufacture: LEADER ELECTRONICS INC. M/N: MT12-4120100-A1 Cable: Unshielded, Detachable, 1.5m
Date of Test	:	Jul.07~17, 2007

2.2. Tested Supporting System Details

2.2.1. PC 1#

EMC CODE : Test PC G
M/N : AG017PA#AB2
S/N : CN5470G18
Manufacturer : HP
Power cord : Unshielded, detachabled , 1.8m
FCC ID : By DoC
BSMI ID : R33001

2.2.2. PC 2#

EMC CODE : Test PC F
M/N : HP Pavilion W1000
S/N : THT442106N
Manufacturer : HP
Power Cord : Unshielded, Detachabled, 1.8m
FCC ID : By DoC
BSMI ID : R33001

2.2.3. MONITOR 1#

EMC CODE : Test Monitor B
M/N : E772F
S/N : CN-02W486-64180-3CE-00LA
Manufacturer : Dell
Data Cable : Shielded, Undetachabled, 1.8m
Power cord : Unshielded, detachabled , 1.8m
FCC ID : By DoC
BSMI ID : N/A

2.2.4. MONITOR 2#

EMC CODE : ACS-EMC-LM02R
M/N : 1907FPt
S/N : CN-009759-71618-6AP-ACPP
Manufacturer : DELL
Data Cable (VGA) : Shielded, Detachabled, 2.0m
Data Cable (DVI) : Shielded, Detachabled, 2.0m
Power Cord : Unshielded, Detachabled, 1.8m
FCC ID : By DoC

2.2.5.MOUSE 1#

EMC CODE : ACS-EMC-M05R
M/N : N3+ Optical
S/N : K043240960
Manufacturer : HP
Data Cable : Shielded, Undetachabled, 1.8m
FCC ID : By DoC
BSMI ID : R31258

2.2.6.MOUSE 2#

EMC CODE : ACS-EMC-M08R
M/N : M056UOA
S/N : F1800P4E
Manufacturer : DELL
Data Cable : Shielded, Undetachabled, 2.0m
FCC ID : By DoC
BSMI ID : R41108

2.2.7.KEYBOARD 1#

EMC CODE : ACS-EMC-K05R
M/N : HP3310
Manufacturer : HP
Data Cable : Shielded, Undetachabled, 2.7m
FCC ID : By DoC
BSMI ID : N/A

2.2.8.KEYBOARD 2#

EMC CODE : ACS-EMC-K04R
M/N : SK-3210
Manufacturer : Dell
Data Cable : Shielded, Undetachabled, 3.1m
FCC ID : By DoC
BSMI ID : 3902B761

2.2.9.MODEM

EMC CODE : ACS-EMC-MD01
M/N : 1414
S/N : 980013578
Manufacturer : ACEEX
Data Cable : Shielded, Detachabled, 1.5m
Power Adaptor : Unshielded, Detachabled, 1.6
Adaptor Manufacturer : TGL
Adaptor Model No : MDE130100TH
FCC ID : IFAXDM1414
BSMI ID : N/A

2.2.10.PRINTER

EMC CODE : ACS-EMC-PT01
M/N : 2225C
Manufacturer : HP
Data Cable : Shielded, Detachabled, 1.5m
Power Cord : Unshielded, Detachabled, 1.8m
FCC ID : BS46XU2225C
BSMI ID : N/A

2.3. Test Facility

Site Description

- 3m Anechoic Chamber : Certificated by FCC, USA
Registration Number: 90454
Jun. 13, 2006
- 3m & 10m Anechoic Chamber : Certificated by FCC, USA
Registration Number: 794232
Jan. 31, 2007
- EMC Lab. : Certificated by DATech, German
Registration Number: DAT-P-091/99-01
Feb. 02, 2004
- Certificated by NVLAP, USA
NVLAP Code: 200372-0
Apr.01, 2006
- Certificated by Nemko, Norway
Aut. No.: ELA135
April. 22, 2004
- Certificated by Industry Canada
Registration Number: IC 5183A-1
Jul. 28, 2004
- Name of Firm : Audix Technology (Shenzhen) Co., Ltd.
- Site Location : No. 6, Ke Feng Rd., 52 Block,
Shenzhen Science & Industrial Park,
Nantou, Shenzhen, Guangdong, China

2.4. Measurement Uncertainty

No.	Item	Uncertainty
1.	Uncertainty for Conducted Emission Test	1.22dB
2.	Uncertainty for Radiated Emission Test<1GHz	4.62dB
3.	Uncertainty for Radiated Emission Test>1GHz	4.79dB
4.	Uncertainty for Frequency measure	0.42×10^{-6}
5.	Uncertainty for conducted power measure	0.112

3. POWER LINE CONDUCTED EMISSION TEST

3.1. Test Equipments

Item	Equipment	Manufacturer	Model No.	Serial No.	Last Cal.	Cal. Interval
1.	Test Receiver	Rohde & Schwarz	ESHS10	838693/001	May 11, 07	1 Year
2.	L.I.S.N.#1	Rohde & Schwarz	ESH2-Z5	834066/011	May 11, 07	1 Year
3.	L.I.S.N.#2	Kyoritsu	KNW-407	8-1636-1	May 11, 07	1 Year
4.	Terminator	Hubersuhner	50Ω	No. 1	May 11, 07	1 Year
5.	RF Cable	MIYAZAKI	5D-2W	LISN Cable 1#	Feb.16, 07	1/2 Year
6.	Coaxial Switch	Anritsu	MP59B	M55367	Feb.16, 07	1/2 Year
7.	Pulse Limiter	Rohde & Schwarz	ESH3-Z2	100340	Feb.16, 07	1/2 Year

3.2. Block Diagram of Test Setup

3.2.1. Block diagram of connection between the EUT and simulators

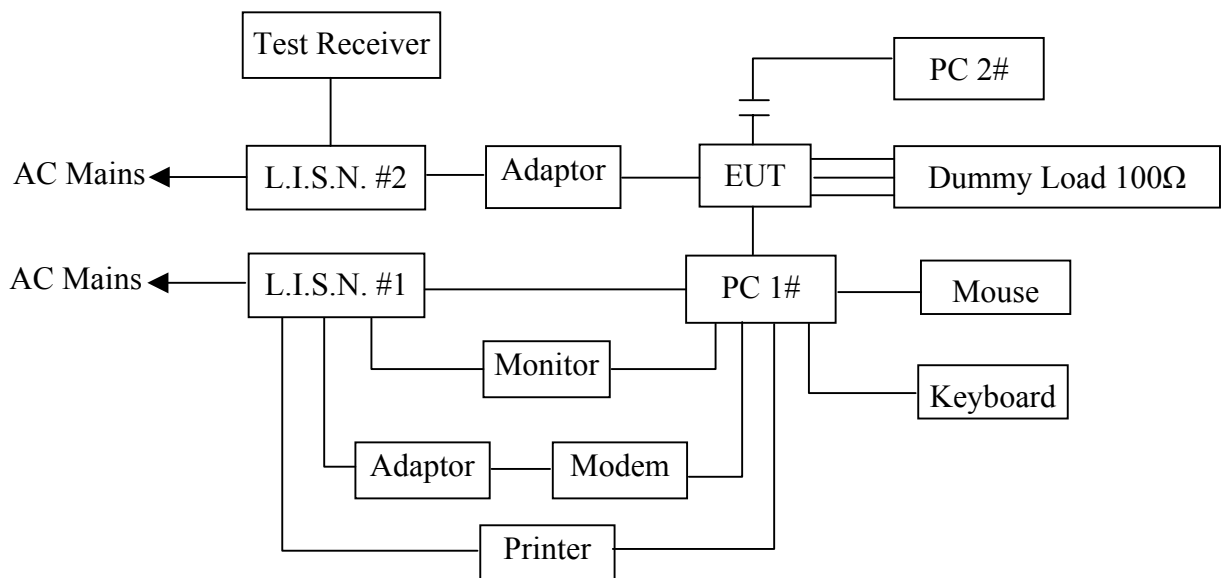

(EUT: 108M Wireless ADSL2 + Router)

3.3. Power Line Conducted Emission Test Limits

Frequency	Maximum RF Line Voltage	
	Quasi-Peak Level dB(μV)	Average Level dB(μV)
150kHz ~ 500kHz	66 ~ 56*	56 ~ 46*
500kHz ~ 5MHz	56	46
5MHz ~ 30MHz	60	50

Notes: 1. * Decreasing linearly with logarithm of frequency.

2. The lower limit shall apply at the transition frequencies.

3.4. Configuration of EUT on Test

The following equipment are installed on Power Line Conducted Emission Test to meet the commission requirement and operating regulations in a manner which tends to maximize its emission characteristics in a normal application.

3.4.1. 108M Wireless ADSL2 + Router (EUT)

Model Number : TD-W8920G
Serial Number : N/A
Manufacturer : TP-LINK Technologies Co., Ltd

3.4.2. Support Equipment : As Tested Supporting System Detail, in Section 2.2..

3.5. Operating Condition of EUT

3.5.1. Setup the EUT and simulator as shown as Section 3.2.

3.5.2. Turn on the power of all equipment.

3.5.3. PC 2# running Ping program with one LAN port of the EUT

3.5.4. PC 1# running Ping program with the other one LAN port of the EUT

3.5.5. PC 2# also running the Control program which can make the EUT work in test mode (TX mode)

3.5.6. The other ports of the EUT was connected to a 100Ω Dummy Load.

3.6. Test Procedure

The EUT is connected to the power mains through a line impedance stabilization network (L.I.S.N.#2). This provides a 50 ohm coupling impedance for the EUT. Please refer the block diagram of the test setup and photographs. The other peripheral devices power cord connected to the power mains through a line impedance stabilization network (L.I.S.N.#1). Power on the PC and let it work normally, we use a keyboard test soft ware, let EUT working in test mode, then test it. Both sides of AC line are checked to find out the maximum conducted emission. In order to find the maximum emission levels, the relative positions of equipment and all of the interface cables shall be changed according to ANSI C63.4: 2003 on Conducted Emission Test.

The bandwidth of test receiver (R & S ESHS10) is set at 10kHz.

The frequency range from 150kHz to 30MHz is checked.

The test result are reported on Section 3.7.,

3.7. Power Line Conducted Emission Test Results

PASS.



No.6 ke Feng Road ,Block 52,
Shenzhen Science & Industry Park
Nantou, Shenzhen, Guangdong, China
Tel:+86-755-26639495-7
Fax:+86-755-26632877
Postcode:518057

Data: 14

File: D:\DATA\2007 Report\TTP-LINK\ACS7Q666.EMI (18)

Date: 2007-07-07

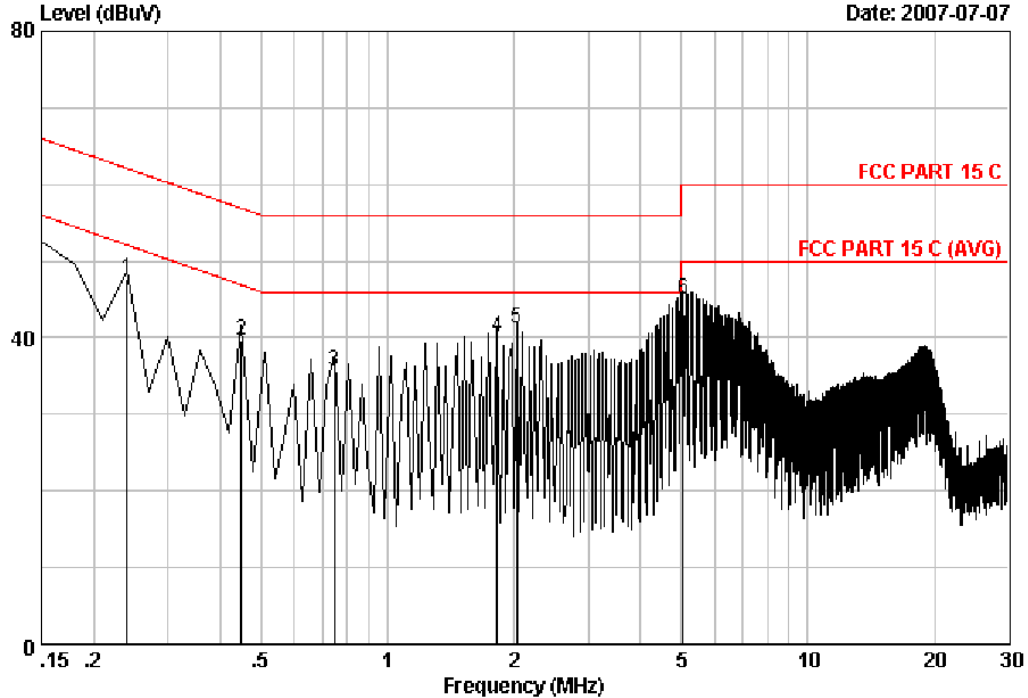

Site no. : Audix 1# Conduction Data no. : 14
 Dis. / Ant. : -- KNW407 VA (1#) LISN Phase :
 Limit : FCC PART 15 C
 Env. / Ins. : Temp:23° Humi:54% ESHS10 Engineer : Jany
 EUT : 108M Wireless ADSL2+Router M/N:TD-W8920G
 Power Rating : DC 12V Adapter input 120V/60Hz
 Test Mode : Tx Mode

Freq. (MHz)	LISN.		Cable		Emission			Remark
	Factor (dB)	Loss (dB)	Reading (dBUV)	Level (dBUV)	Limits (dBUV)	Margin (dB)		
1	0.24	0.14	10.15	37.42	47.71	62.11	14.40	QP
2	0.45	0.07	10.14	29.39	39.60	56.90	17.30	QP
3	0.75	0.05	10.14	25.48	35.67	56.00	20.33	QP
4	1.82	0.05	10.15	29.97	40.17	56.00	15.83	QP
5	2.03	0.05	10.15	30.98	41.18	56.00	14.82	QP
6	5.05	0.10	10.19	34.73	45.02	60.00	14.98	QP

Remarks: 1. Emission Level= LISN Factor + Cable Loss + Reading.
 2. If the average limit is met when using a quasi-peak detector,
 the EUT shall be deemed to meet both limits and measurement
 with average detector is unnecessary.



No.6 ke Feng Road ,Block 52,
Shenzhen Science & Industry Park
Nantou, Shenzhen, Guangdong, China
Tel:+86-755-26639495-7
Fax:+86-755-26632877
Postcode:518057

Data: 13

File: D:\DATA\2007 Report\TTP-LINK\ACS7Q666.EMI (18)

Date: 2007-07-07

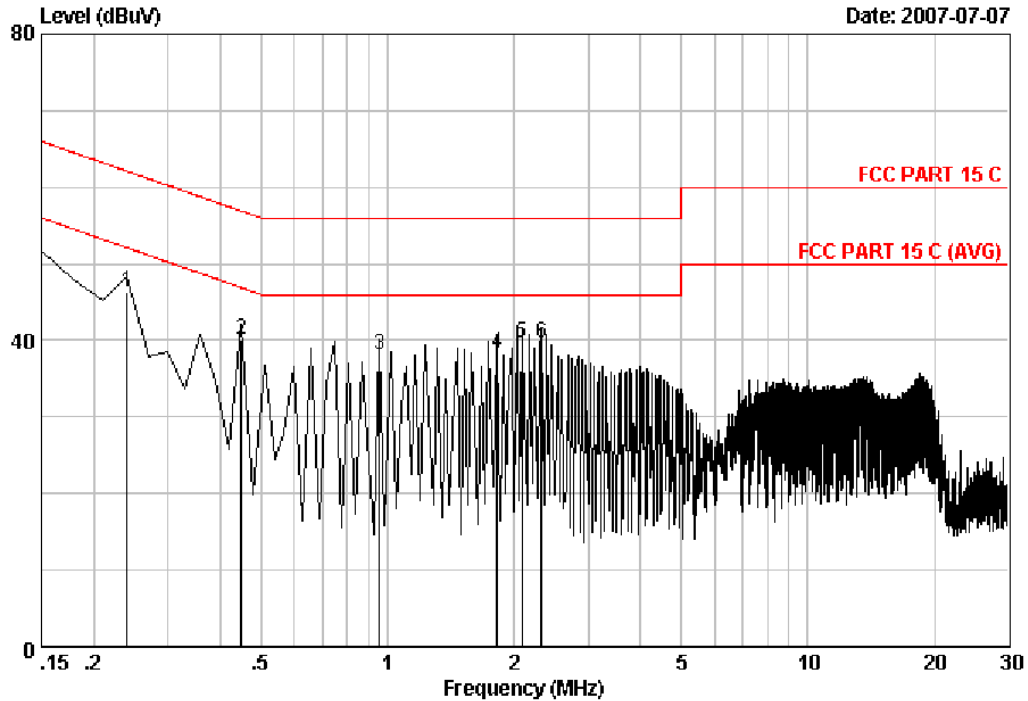

Site no. : Audix 1# Conduction Data no. : 13
 Dis. / Ant. : -- KNW407 VB (1#) LISN Phase :
 Limit : FCC PART 15 C
 Env. / Ins. : Temp:23° Humi:54% ESHS10 Engineer : Jamy
 EUT : 108M Wireless ADSL2+Router M/N:TD-W8920G
 Power Rating : DC 12V Adapter input 120V/60Hz
 Test Mode : Tx Mode

Freq. (MHz)	LISN.		Cable		Emission			Remark
	Factor (dB)	Loss (dB)	Reading (dBuV)	Level (dBuV)	Limits (dBuV)	Margin (dB)		
1	0.24	0.14	10.15	35.96	46.25	62.11	15.86	QP
2	0.45	0.07	10.14	29.95	40.16	56.90	16.74	QP
3	0.96	0.04	10.15	27.93	38.12	56.00	17.88	QP
4	1.82	0.05	10.15	28.22	38.42	56.00	17.58	QP
5	2.09	0.05	10.15	29.53	39.73	56.00	16.27	QP
6	2.33	0.06	10.16	29.47	39.69	56.00	16.31	QP

Remarks: 1. Emission Level= LISN Factor + Cable Loss + Reading.
 2. If the average limit is met when using a quasi-peak detector,
 the EUT shall be deemed to meet both limits and measurement
 with average detector is unnecessary.

4. RADIATED EMISSION TEST

4.1. Test Equipment

The following test equipments are used during the radiated emission test:

4.1.1. For Anechoic Chamber

Frequency rang: 30~1000MHz

Item	Equipment	Manufacturer	Model No.	Serial No.	Last Cal.	Cal. Interval
1.	EMI Spectrum	HP	85422E	3625A00181	May 11, 07	1 Year
2.	Test Receiver	Rohde & Schwarz	ESVS20	830350/005	May 11, 07	1 Year
3.	Amplifier	HP	8447D	2944A07794	Mar.12, 07	1/2 Year
4.	Bilog Antenna	Schaffner	CBL6111C	2598	Feb.22, 07	1 Year
5.	RF Cable	MIYAZAKI	5D-2W	3# Chamber No.1	Jan. 18, 07	1/2 Year
6.	RF Cable	MIYAZAKI	5D-2W	3# Chamber No.2	Jan. 18,07	1/2 Year
7.	RF Cable	FUJIKURAw	RG-55/U	3# Chamber No.3	Jan. 18,07	1/2 Year
8.	RF Cable	FUJIKURA	RG-55/U	3# Chamber No.4	Jan. 18,07	1/2 Year
9.	Coaxial Switch	Anritsu	MP59B	M73989	Jan. 18,07	1/2 Year

Frequency rang: above 1000MHz

Item	Equipment	Manufacturer	Model No.	Serial No.	Last Cal.	Cal. Interval
1.	Spectrum	Agilent	E4407B	MY41440292	May 11, 07	1 Year
2.	Amp	HP	8449B	3008A00863	May 11, 07	1 Year
3.	Antenna	EMCO	3115	9607-4877	Jan. 23, 07	1.5 Year
4.	HF Cable	Hubersuhne	Sucoflex104	-	May 11, 07	1 Year

4.2. Block Diagram of Test Setup

4.2.1. Block diagram of connection between the EUT and simulators

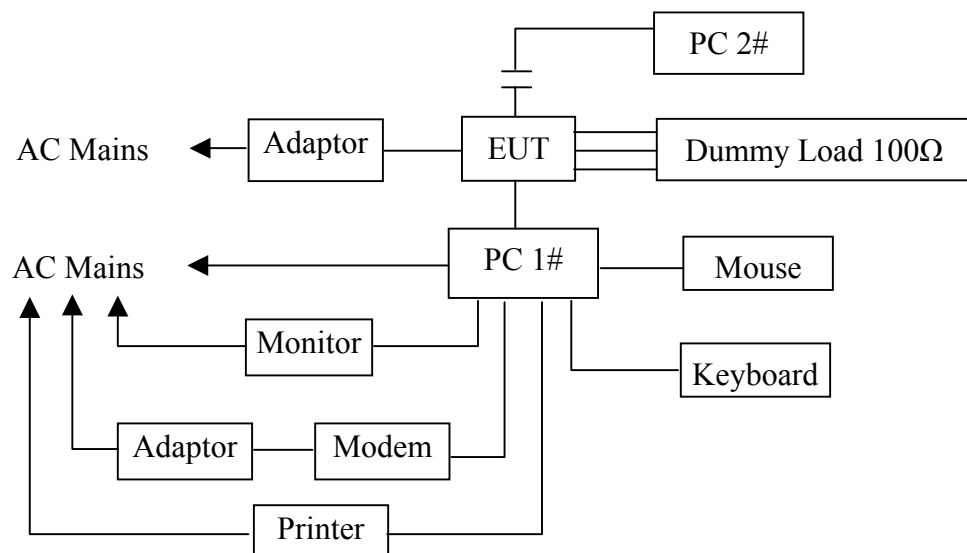

(EUT: 108M Wireless ADSL2 + Router)

4.2.2.In Anechoic Chamber

ANTENNA TOWER

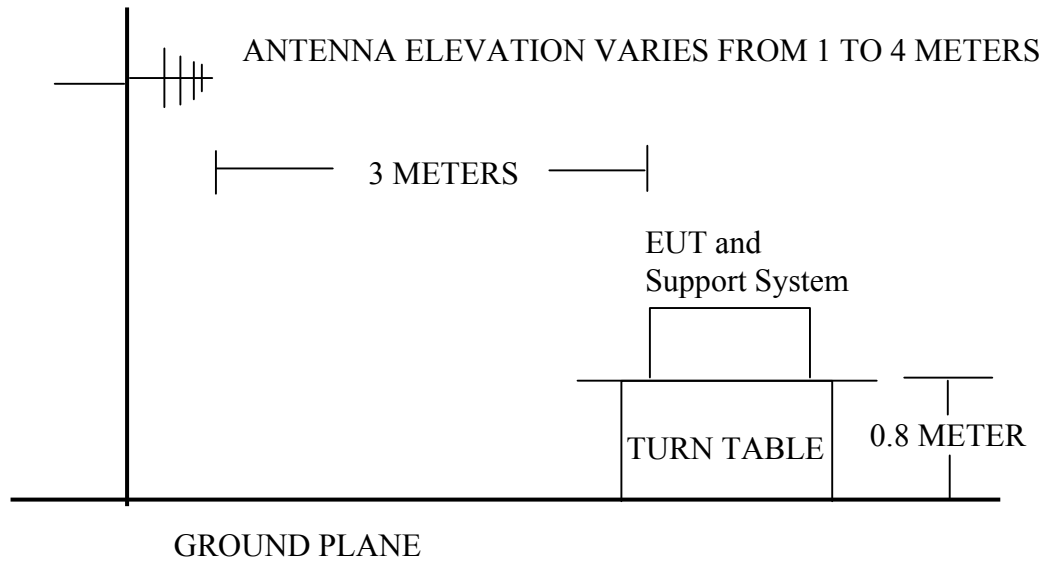

4.3.Radiated Emission Limit

FREQUENCY MHz	DISTANCE Meters	FIELD STRENGTHS LIMIT	
		$\mu\text{V}/\text{m}$	$\text{dB}(\mu\text{V})/\text{m}$
30 ~ 88	3	100	40.0
88 ~ 216	3	150	43.5
216 ~ 960	3	200	46.0
960 ~ 1000	3	500	54.0
Above 1000	3	74.0 $\text{dB}(\mu\text{V})/\text{m}$ (Peak) 54.0 $\text{dB}(\mu\text{V})/\text{m}$ (Average)	

- Remark :
- (1) Emission level $\text{dB}\mu\text{V} = 20 \log$ Emission level $\mu\text{V}/\text{m}$
 - (2) The smaller limit shall apply at the cross point between two frequency bands.
 - (3) Distance is the distance in meters between the measuring instrument, antenna and the closest point of any part of the device or system.

4.4.EUT Configuration on Test

The following equipment are installed on Radiated Emission Test to meet the commission requirements and operating regulations in a manner which tends to maximize its emission characteristics in normal application.

4.4.1.108M Wireless ADSL2 + Router (EUT)

Model Number : TD-W8920G
 Serial Number : N/A
 Manufacturer : TP-LINK Technologies Co., Ltd

4.4.2.Support Equipment : As Tested Supporting System Detail, in Section 2.2.

4.5. Operating Condition of EUT

- 4.5.1. Setup the EUT and simulator as shown as Section 4.2.
- 4.5.2. Turn on the power of all equipment.
- 4.5.3. PC 2# running Ping program with one LAN port of the EUT
- 4.5.4. PC 1# running Ping program with the other one LAN port of the EUT
- 4.5.5. PC 2# also running the Control program which can make the EUT work in test mode (TX mode)
- 4.5.6. The other ports of the EUT was connected to a 100Ω Dummy Load

4.6. Test Procedure

EUT and its simulators are placed on a turn table, which is 0.8 meter high above ground. The turn table can rotate 360 degrees to determine the position of the maximum emission level. Power on the EUT and let it work normally, we use a keyboard test soft ware, let EUT working in test mode, then test it. EUT is set 3 meters away from the receiving antenna, which is mounted on a antenna tower. The antenna can be moved up and down between 1 meter and 4 meters to find out the maximum emission level. Broadband antenna (calibrated bilog antenna) is used as receiving antenna. Both horizontal and vertical polarization of the antenna are set on test.

The bandwidth of the EMI test receiver (R&S ESVS20) is set at 120kHz.

frequency range from 30MHz to 1000 MHz.

The bandwidth of the VBW is set at 1MHz and RBW is set at 1MHz for peak emissions measurement above 1GHz and 1MHz RBW 10Hz VBW for average emission above 1GHz

The frequency range from 30MHz to 10th harmonic are checked.

The test modes (IEEE 802.11b TX/ IEEE 802.11g TX) is tested in Anechoic Chamber and all the scanning waveforms are reported with antenna in horizontal and vertical polarization on Section 4.7.

4.7. Radiated Emission Test Results

PASS.

The frequency range from 30MHz to 1000MHz and above 1GHz. is investigated. Please see the following pages.

All the emissions except fundamental from 18GHz~24GHz are at least 20dB below the limit, and do not record.



No.6 Ke Feng Road,B1;ck 52,
ShenZhen Science & Industry Park
Noutou, ShenZhen, GuangDong, China
Tel:+86-755-26639495-7
Fax:+86-755-26632877
Postcode:518057

Data: 19 File: D:\2007 Report\T\TP-Link\W8920G\LRE\ACS7Q666.EMI (19)

Date: 2007-07-14

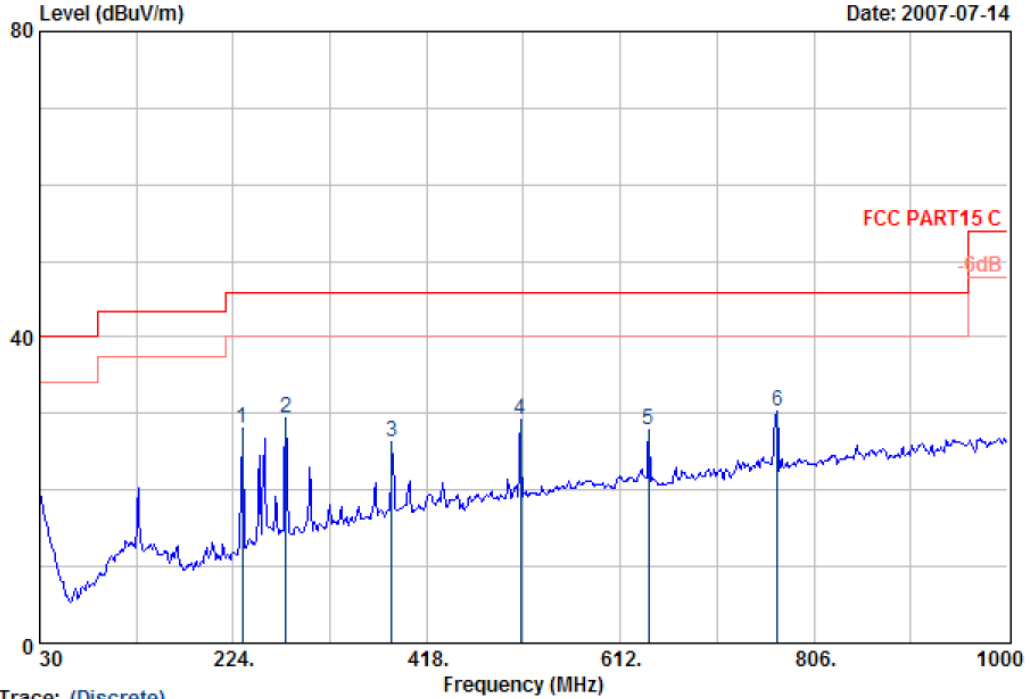

Trace: (Discrete)

Site no. : 3# Chamber Radiation Data no. : 19
 Dis. / Ant. : 3m 2598 Ant. pol. : HORIZONTAL
 Limit : FCC PART15 C
 Env. / Ins. : 24°C/56% ESVS20 Engineer : Jamy
 EUT : 108M Wireless ADSL2+Router M/N:TD-W8920G
 Power Rating : DC 12V From adapter 120V/60Hz
 Test Mode : Tx mode

	Freq. (MHz)	Ant. Factor (dB/m)	Cable Loss (dB)	Reading (dBuV)	Emission Level (dBuV/m)	Limits (dBuV/m)	Margin (dB)	Remark
1	232.73	11.24	1.46	15.43	28.13	46.00	17.87	QP
2	276.38	13.30	1.50	14.55	29.35	46.00	16.65	QP
3	383.08	15.96	1.78	8.65	26.39	46.00	19.61	QP
4	512.09	18.24	2.18	8.83	29.25	46.00	16.75	QP
5	640.13	20.30	2.32	5.15	27.77	46.00	18.23	QP
6	769.14	21.80	2.23	6.22	30.25	46.00	15.75	QP

Remarks: 1. Emission Level= Antenna Factor + Cable Loss + Reading.
 2. The emission levels that are 20dB below the official limit are not reported.



No.6 Ke Feng Road,B1:ck 52,
 ShenZhen Science & Industry Park
 Noutou, ShenZhen, GuangDong, China
 Tel:+86-755-26639495-7
 Fax:+86-755-26632877
 Postcode:518057

Data: 18 File: D:\2007 Report\TTP-Link\W8920G\LRE\ACS7Q666.EMI (19)

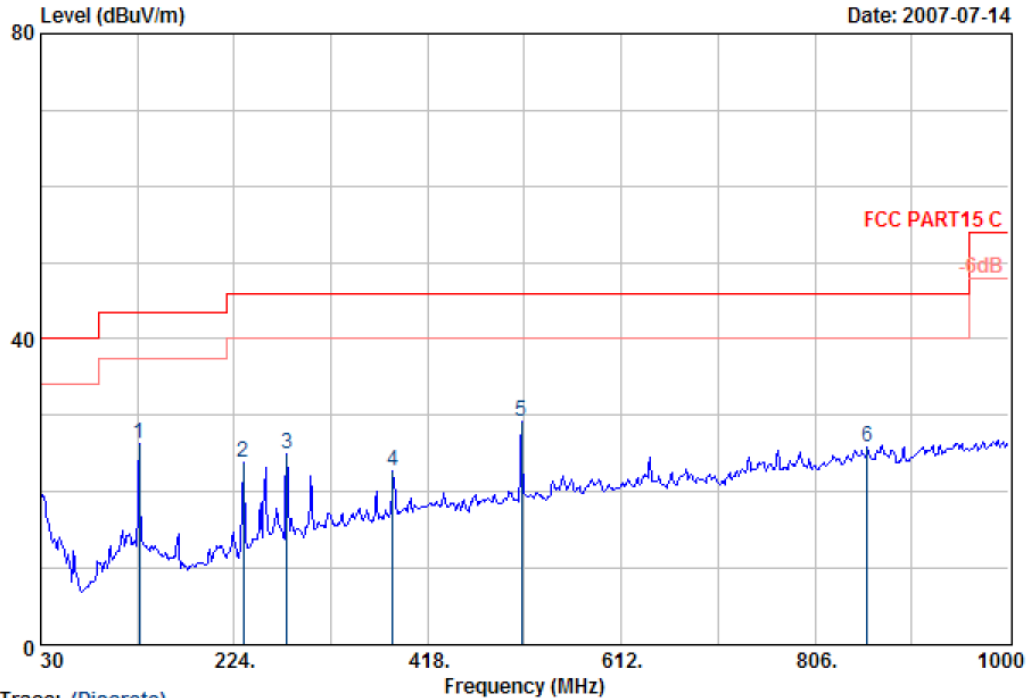

Trace: (Discrete)
 Site no. : 3# Chamber Radiation Data no. : 18
 Dis. / Ant. : 3m 2598 Ant. pol. : VERTICAL
 Limit : FCC PART15 C
 Env. / Ins. : 24°C/56% ESVS20 Engineer : Jamy
 EUT : 108M Wireless ADSL2+Router M/N:TD-W8920G
 Power Rating : DC 12V From adapter 120V/60Hz
 Test Mode : Tx mode

	Freq. (MHz)	Ant. Factor (dB/m)	Cable Loss (dB)	Reading (dBuV)	Emission Level (dBuV/m)	Limits (dBuV/m)	Margin (dB)	Remark
1	128.94	12.04	1.11	13.24	26.39	43.50	17.11	QP
2	232.73	11.24	1.46	11.12	23.82	46.00	22.18	QP
3	276.38	13.30	1.50	10.11	24.91	46.00	21.09	QP
4	383.08	15.96	1.78	4.94	22.68	46.00	23.32	QP
5	512.09	18.24	2.18	8.78	29.20	46.00	16.80	QP
6	858.38	22.76	2.75	0.36	25.87	46.00	20.13	QP

Remarks: 1. Emission Level= Antenna Factor + Cable Loss + Reading.
 2. The emission levels that are 20dB below the official limit are not reported.



No.6 Ke Feng Road,B1:ck 52,
 ShenZhen Science & Industry Park
 Noutou, ShenZhen, GuangDong, China
 Tel:+86-755-26639495-7
 Fax:+86-755-26632877
 Postcode:518057

Data: 3 File: D:\2007 Report\TTP-Link\W8920G\HRE\ACS7Q666.EMI (42)

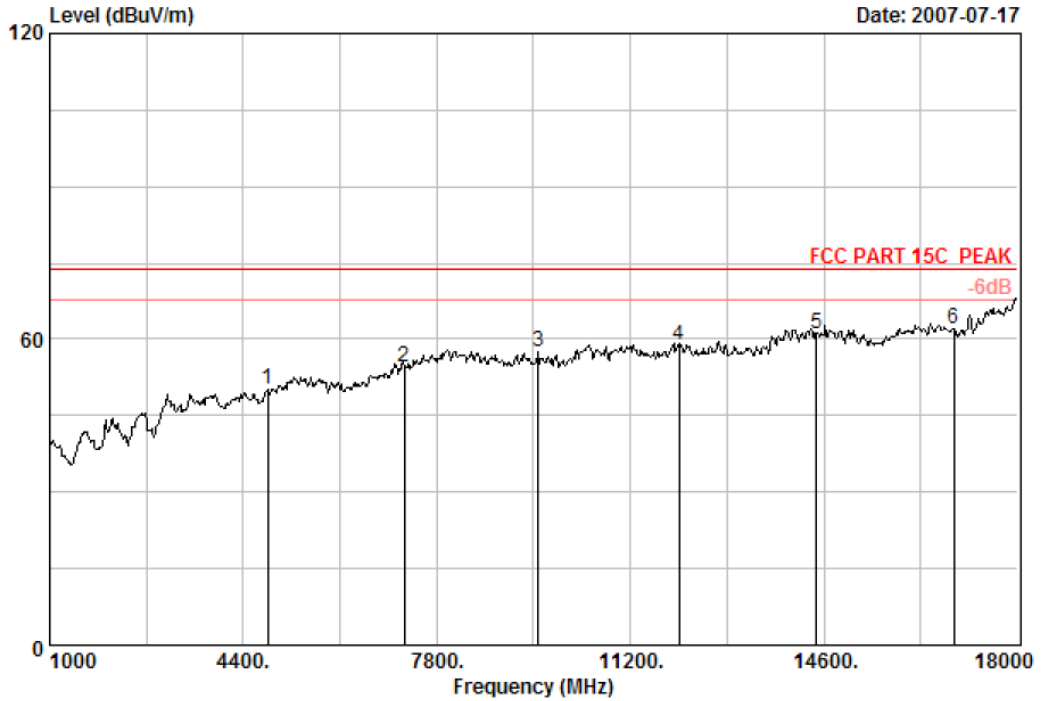

Site no. : Audix No.1 Chamber Data no. : 3
 Dis. / Ant. : 3m 3115 FACTOR Ant. pol. : HORIZONTAL
 Limit : FCC PART 15C PEAK
 Env. / Ins. : 23°C/54% Engineer : Jamy
 EUT : 108M Wireless ADSL2+Router M/N:TD-W8920G
 Power Rating : DC 12V From Adapter 120V/60Hz
 Test Mode : IEEE 802.11b TX in CH1 2412MHz

	Freq. (MHz)	Ant. Factor (dB/m)	Cable Loss (dB)	Amp Factor (dB)	Emission				Remark
					Reading (dBuV)	Level (dBuV/m)	Limits (dBuV/m)	Margin (dB)	
1	4824.00	34.02	9.05	34.49	41.60	50.18	74.00	23.82	Peak
2	7236.00	37.39	10.94	34.44	40.60	54.49	74.00	19.51	Peak
3	9585.00	38.16	11.87	35.86	43.37	57.54	74.00	16.46	Peak
4	12060.00	39.54	13.59	36.38	42.20	58.95	74.00	15.05	Peak
5	14472.00	42.27	13.85	35.46	40.64	61.30	74.00	12.70	Peak
6	16884.00	39.68	15.48	34.83	41.70	62.03	74.00	11.97	Peak

Remarks: 1. Emission Level= Antenna Factor + Cable Loss - Amp Factor + Reading.
 2. The emission levels that are 20dB below the official limit are not reported.



No.6 Ke Feng Road,B1:ck 52,
 ShenZhen Science & Industry Park
 Noutou, ShenZhen, GuangDong, China
 Tel:+86-755-26639495-7
 Fax:+86-755-26632877
 Postcode:518057

Data: 4 File: D:\2007 Report\TTP-Link\W8920G\HRE\ACS7Q666.EMI (42)

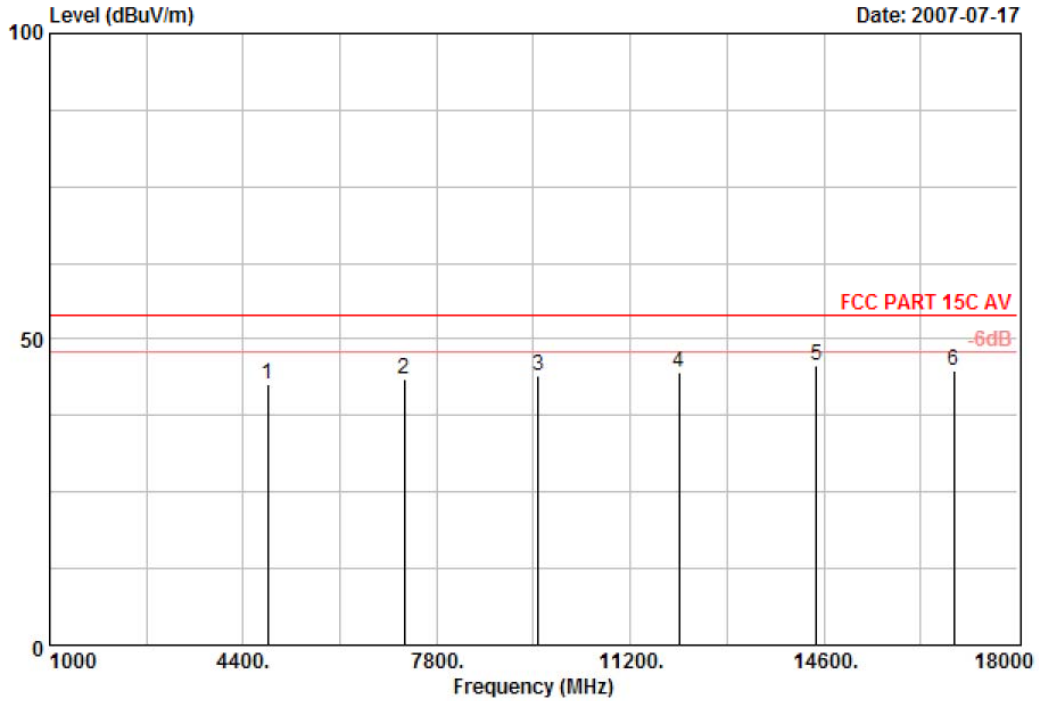

Site no. : Audix No.1 Chamber Data no. : 4
 Dis. / Ant. : 3m 3115 FACTOR Ant. pol. : HORIZONTAL
 Limit : FCC PART 15C AV
 Env. / Ins. : 23°C/54% Engineer : Jamy
 EUT : 108M Wireless ADSL2+Router M/N:TD-W8920G
 Power Rating : DC 12V From Adapter 120V/60Hz
 Test Mode : IEEE 802.11b TX in CH1 2412MHz

	Freq. (MHz)	Ant. Factor (dB/m)	Cable Loss (dB)	Amp Factor (dB)	Reading (dBuV)	Emission		Margin (dB)	Remark
						Level (dBuV/m)	Limits (dBuV/m)		
1	4824.00	34.02	9.05	34.49	34.09	42.67	54.00	11.33	Average
2	7236.00	37.39	10.94	34.44	29.47	43.36	54.00	10.64	Average
3	9585.00	38.16	11.87	35.86	29.77	43.94	54.00	10.06	Average
4	12060.00	39.54	13.59	36.38	27.76	44.51	54.00	9.49	Average
5	14472.00	42.27	13.85	35.46	24.95	45.61	54.00	8.39	Average
6	16884.00	39.68	15.48	34.83	24.40	44.73	54.00	9.27	Average

Remarks: 1. Emission Level= Antenna Factor + Cable Loss - Amp Factor + Reading.
 2. The emission levels that are 20dB below the official limit are not reported.



No.6 Ke Feng Road,B1:ck 52,
 ShenZhen Science & Industry Park
 Noutou, ShenZhen, GuangDong, China
 Tel:+86-755-26639495-7
 Fax:+86-755-26632877
 Postcode:518057

Data: 1 File: D:\2007 Report\T\TP-Link\W8920G\HRE\ACS7Q666.EMI (42)

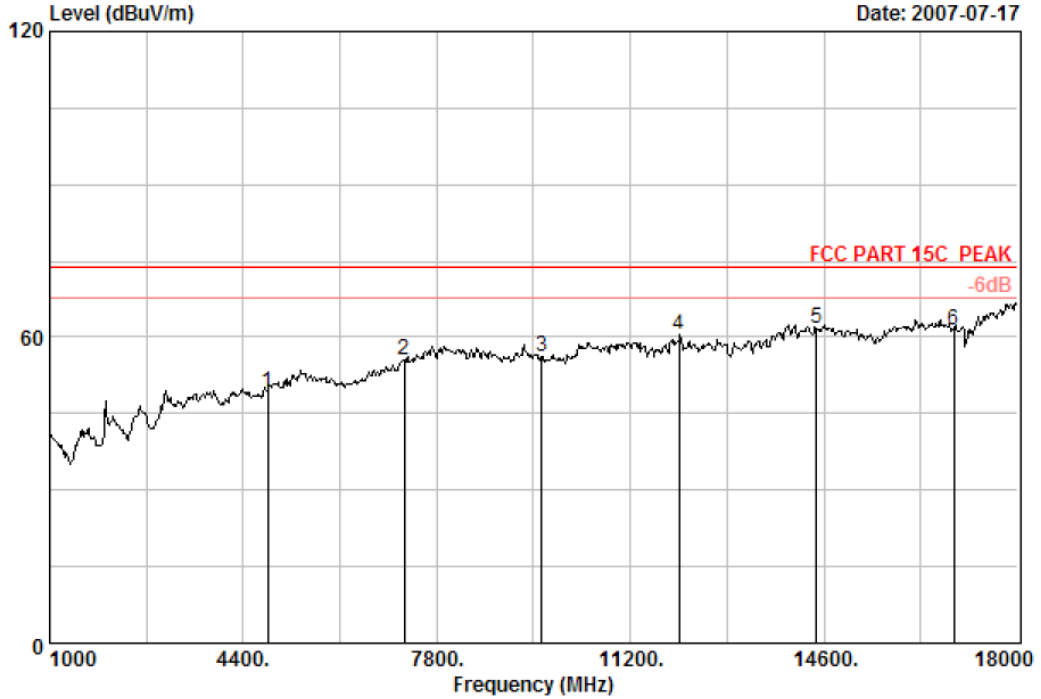

Site no. : Audix No.1 Chamber Data no. : 1
 Dis. / Ant. : 3m 3115 FACTOR Ant. pol. : VERTICAL
 Limit : FCC PART 15C PEAK
 Env. / Ins. : 23°C/54% Engineer : Jamy
 EUT : 108M Wireless ADSL2+Router M/N:TD-W8920G
 Power Rating : DC 12V From Adapter 120V/60Hz
 Test Mode : IEEE 802.11b TX in CH1 2412MHz

	Freq. (MHz)	Ant. Factor (dB/m)	Cable Loss (dB)	Amp Factor (dB)	Emission				Remark
					Reading (dBuV)	Level (dBuV/m)	Limits (dBuV/m)	Margin (dB)	
1	4824.00	34.02	9.05	34.49	40.55	49.13	74.00	24.87	Peak
2	7236.00	37.39	10.94	34.44	41.47	55.36	74.00	18.64	Peak
3	9648.00	38.11	11.86	35.92	42.07	56.12	74.00	17.88	Peak
4	12060.00	39.54	13.59	36.38	43.92	60.67	74.00	13.33	Peak
5	14472.00	42.27	13.85	35.46	41.33	61.99	74.00	12.01	Peak
6	16884.00	39.68	15.48	34.83	41.31	61.64	74.00	12.36	Peak

Remarks: 1. Emission Level= Antenna Factor + Cable Loss - Amp Factor + Reading.
 2. The emission levels that are 20dB below the official limit are not reported.



No.6 Ke Feng Road,B1:ck 52,
ShenZhen Science & Industry Park
Noutou, ShenZhen, GuangDong, China
Tel:+86-755-26639495-7
Fax:+86-755-26632877
Postcode:518057

Data: 2 File: D:\2007 Report\T\TP-Link\W8920G\HRE\ACS7Q666.EMI (42)

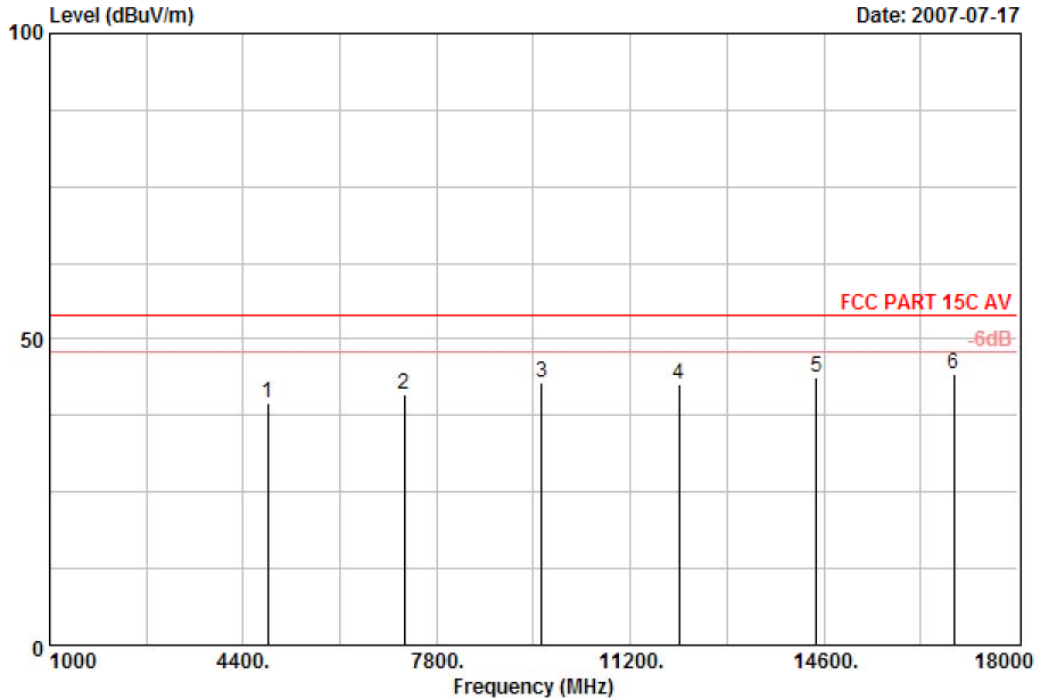

Site no. : Audix No.1 Chamber Data no. : 2
 Dis. / Ant. : 3m 3115 FACTOR Ant. pol. : VERTICAL
 Limit : FCC PART 15C AV
 Env. / Ins. : 23°C/54% Engineer : Jamy
 EUT : 108M Wireless ADSL2+Router M/N:TD-W8920G
 Power Rating : DC 12V From Adapter 120V/60Hz
 Test Mode : IEEE 802.11b TX in CH1 2412MHz

	Freq. (MHz)	Ant. Factor (dB/m)	Cable Loss (dB)	Amp Factor (dB)	Emission		Limits (dBuV/m)	Margin (dB)	Remark
					Reading (dBuV)	Level (dBuV/m)			
1	4824.00	34.02	9.05	34.49	31.09	39.67	54.00	14.33	Average
2	7236.00	37.39	10.94	34.44	26.97	40.86	54.00	13.14	Average
3	9648.00	38.11	11.86	35.92	28.96	43.01	54.00	10.99	Average
4	12060.00	39.54	13.59	36.38	25.76	42.51	54.00	11.49	Average
5	14472.00	42.27	13.85	35.46	23.10	43.76	54.00	10.24	Average
6	16884.00	39.68	15.48	34.83	23.89	44.22	54.00	9.78	Average

Remarks: 1. Emission Level= Antenna Factor + Cable Loss - Amp Factor + Reading.
 2. The emission levels that are 20dB below the official limit are not reported.



No.6 Ke Feng Road,B1:ck 52,
 ShenZhen Science & Industry Park
 Noutou, ShenZhen, GuangDong, China
 Tel:+86-755-26639495-7
 Fax:+86-755-26632877
 Postcode:518057

Data: 5 File: D:\2007 Report\TTP-Link\W8920G\HRE\ACS7Q666.EMI (42)

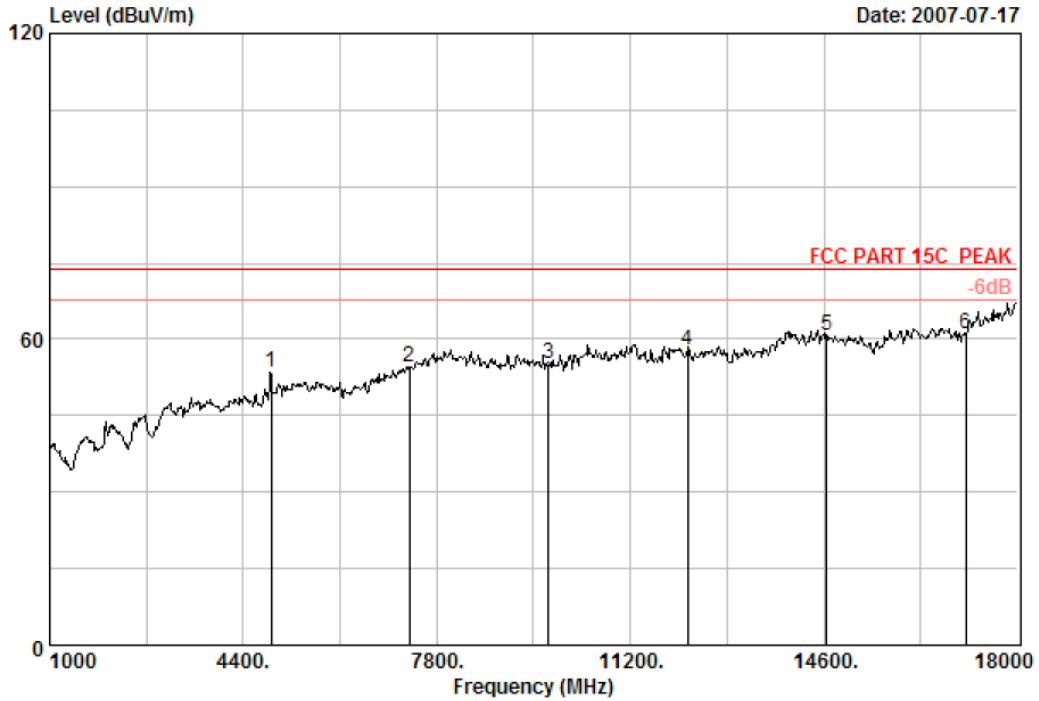

Site no. : Audix No.1 Chamber Data no. : 5
 Dis. / Ant. : 3m 3115 FACTOR Ant. pol. : HORIZONTAL
 Limit : FCC PART 15C PEAK
 Env. / Ins. : 23°C/54% Engineer : Jamy
 EUT : 108M Wireless ADSL2+Router M/N:TD-W8920G
 Power Rating : DC 12V From Adapter 120V/60Hz
 Test Mode : IEEE 802.11b TX in CH7 2442MHz

	Freq. (MHz)	Ant. Factor (dB/m)	Cable Loss (dB)	Amp Factor (dB)	Emission				Remark
					Reading (dBuV)	Level (dBuV/m)	Limits (dBuV/m)	Margin (dB)	
1	4884.00	34.16	9.17	34.48	44.57	53.42	74.00	20.58	Peak
2	7326.00	37.52	11.05	34.47	40.30	54.40	74.00	19.60	Peak
3	9768.00	38.01	11.88	36.02	41.43	55.30	74.00	18.70	Peak
4	12210.00	39.47	13.75	36.33	41.04	57.93	74.00	16.07	Peak
5	14652.00	41.83	14.14	35.38	40.16	60.75	74.00	13.25	Peak
6	17094.00	40.55	15.58	34.87	40.01	61.27	74.00	12.73	Peak

Remarks: 1. Emission Level= Antenna Factor + Cable Loss - Amp Factor + Reading.
 2. The emission levels that are 20dB below the official limit are not reported.



No.6 Ke Feng Road,B1:ck 52,
ShenZhen Science & Industry Park
Noutou, ShenZhen, GuangDong, China
Tel:+86-755-26639495-7
Fax:+86-755-26632877
Postcode:518057

Data: 6 File: D:\2007 Report\T\TP-Link\W8920G\HRE\ACS7Q666.EMI (42)

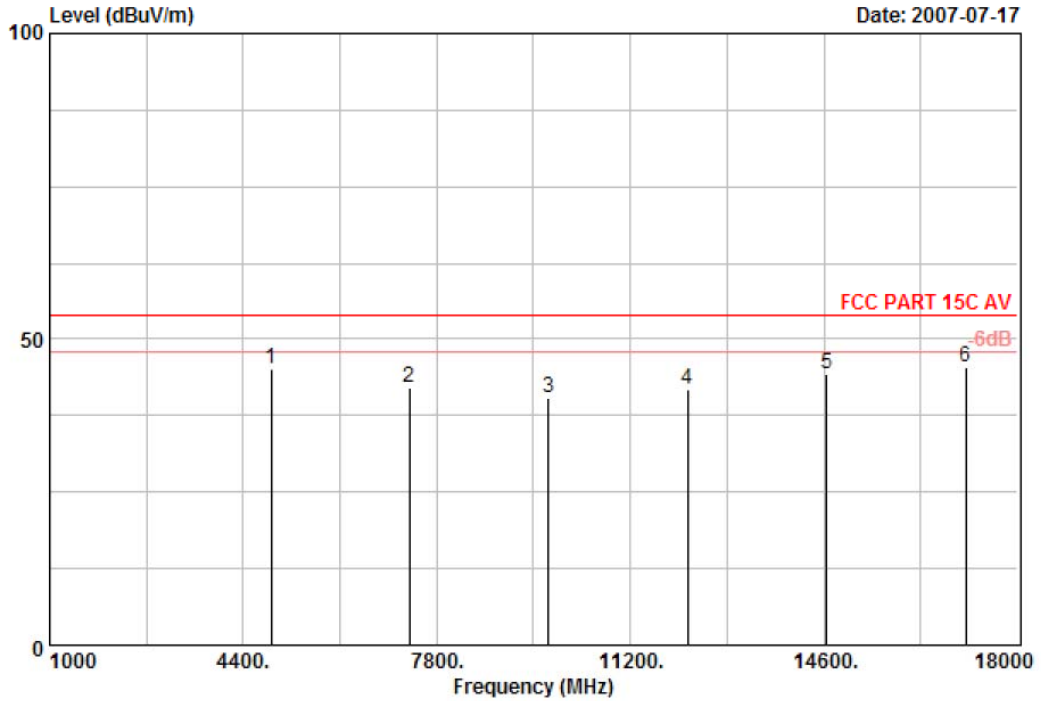

Site no. : Audix No.1 Chamber Data no. : 6
 Dis. / Ant. : 3m 3115 FACTOR Ant. pol. : HORIZONTAL
 Limit : FCC PART 15C AV
 Env. / Ins. : 23°C/54% Engineer : Jamy
 EUT : 108M Wireless ADSL2+Router M/N:TD-W8920G
 Power Rating : DC 12V From Adapter 120V/60Hz
 Test Mode : IEEE 802.11b TX in CH7 2442MHz

	Freq. (MHz)	Ant. Factor (dB/m)	Cable Loss (dB)	Amp Factor (dB)	Emission		Limits (dBuV/m)	Margin (dB)	Remark
					Reading (dBuV)	Level (dBuV/m)			
1	4884.00	34.16	9.17	34.48	36.31	45.16	54.00	8.84	Average
2	7326.00	37.52	11.05	34.47	27.83	41.93	54.00	12.07	Average
3	9768.00	38.01	11.88	36.02	26.50	40.37	54.00	13.63	Average
4	12210.00	39.47	13.75	36.33	24.92	41.81	54.00	12.19	Average
5	14652.00	41.83	14.14	35.38	23.75	44.34	54.00	9.66	Average
6	17094.00	40.55	15.58	34.87	24.09	45.35	54.00	8.65	Average

Remarks: 1. Emission Level= Antenna Factor + Cable Loss - Amp Factor + Reading.
 2. The emission levels that are 20dB below the official limit are not reported.



No.6 Ke Feng Road,B1:ck 52,
 ShenZhen Science & Industry Park
 Noutou, ShenZhen, GuangDong, China
 Tel:+86-755-26639495-7
 Fax:+86-755-26632877
 Postcode:518057

Data: 7 File: D:\2007 Report\T\TP-Link\W8920G\HRE\ACS7Q666.EMI (42)

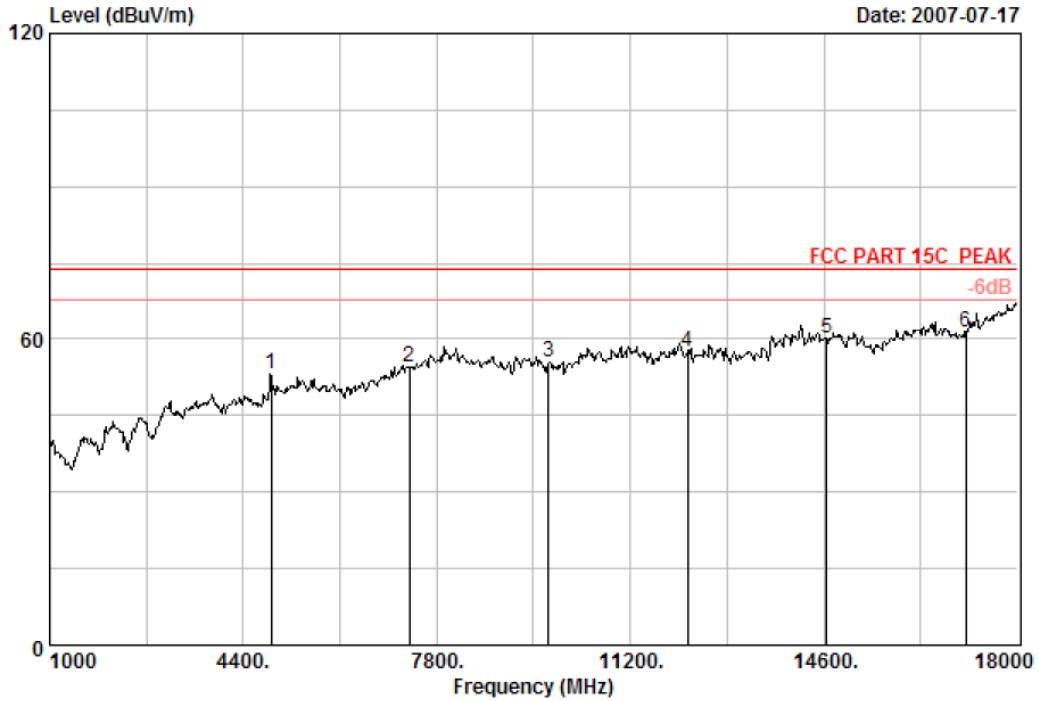

Site no. : Audix No.1 Chamber Data no. : 7
 Dis. / Ant. : 3m 3115 FACTOR Ant. pol. : VERTICAL
 Limit : FCC PART 15C PEAK
 Env. / Ins. : 23°C/54% Engineer : Jamy
 EUT : 108M Wireless ADSL2+Router M/N:TD-W8920G
 Power Rating : DC 12V From Adapter 120V/60Hz
 Test Mode : IEEE 802.11b TX in CH7 2442MHz

	Freq. (MHz)	Ant. Factor (dB/m)	Cable Amp		Emission			Margin (dB)	Remark
			Loss (dB)	Factor (dB)	Reading (dBuV)	Level (dBuV/m)	Limits (dBuV/m)		
1	4884.00	34.16	9.17	34.48	44.35	53.20	74.00	20.80	Peak
2	7326.00	37.52	11.05	34.47	40.30	54.40	74.00	19.60	Peak
3	9768.00	38.01	11.88	36.02	41.73	55.60	74.00	18.40	Peak
4	12210.00	39.47	13.75	36.33	40.60	57.49	74.00	16.51	Peak
5	14652.00	41.83	14.14	35.38	39.66	60.25	74.00	13.75	Peak
6	17094.00	40.55	15.58	34.87	40.16	61.42	74.00	12.58	Peak

Remarks: 1. Emission Level= Antenna Factor + Cable Loss - Amp Factor + Reading.
 2. The emission levels that are 20dB below the official limit are not reported.



No.6 Ke Feng Road,B1:ck 52,
 ShenZhen Science & Industry Park
 Noutou, ShenZhen, GuangDong, China
 Tel:+86-755-26639495-7
 Fax:+86-755-26632877
 Postcode:518057

Data: 8 File: D:\2007 Report\T\TP-Link\W8920G\HRE\ACS7Q666.EMI (42)

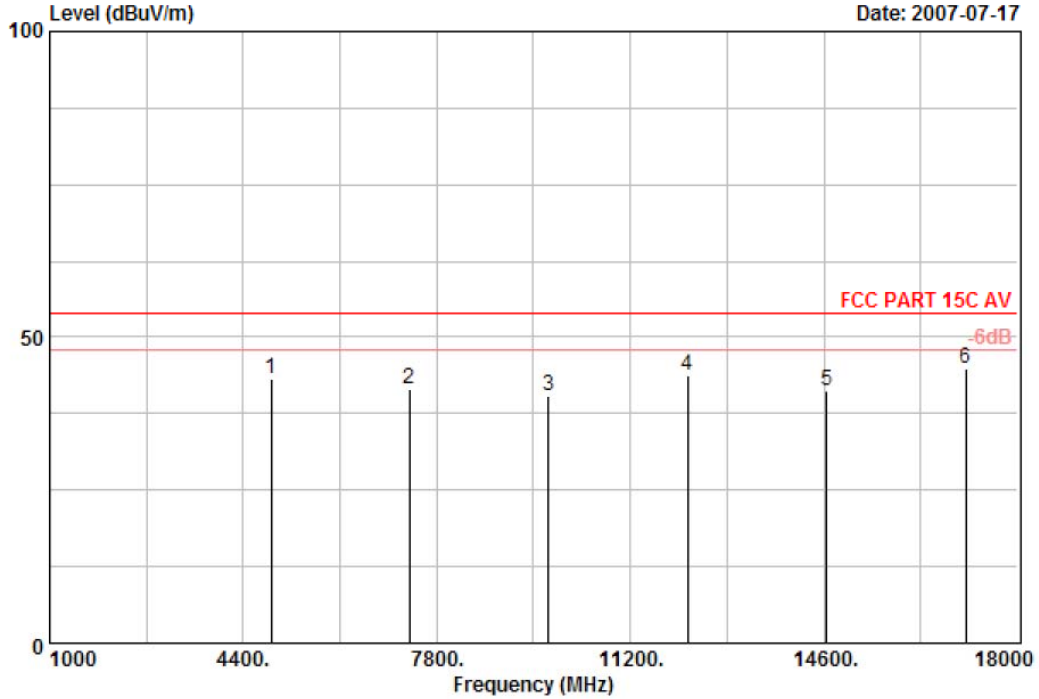

Site no. : Audix No.1 Chamber Data no. : 8
 Dis. / Ant. : 3m 3115 FACTOR Ant. pol. : VERTICAL
 Limit : FCC PART 15C AV
 Env. / Ins. : 23°C/54% Engineer : Jamy
 EUT : 108M Wireless ADSL2+Router M/N:TD-W8920G
 Power Rating : DC 12V From Adapter 120V/60Hz
 Test Mode : IEEE 802.11b TX in CH7 2442MHz

	Freq. (MHz)	Ant. Factor (dB/m)	Cable Loss (dB)	Amp Factor (dB)	Emission				Remark
					Reading (dBuV)	Level (dBuV/m)	Limits (dBuV/m)	Margin (dB)	
1	4884.00	34.16	9.17	34.48	34.31	43.16	54.00	10.84	Average
2	7326.00	37.52	11.05	34.47	27.33	41.43	54.00	12.57	Average
3	9768.00	38.01	11.88	36.02	26.50	40.37	54.00	13.63	Average
4	12210.00	39.47	13.75	36.33	26.92	43.81	54.00	10.19	Average
5	14652.00	41.83	14.14	35.38	20.75	41.34	54.00	12.66	Average
6	17094.00	40.55	15.58	34.87	23.58	44.84	54.00	9.16	Average

Remarks: 1. Emission Level= Antenna Factor + Cable Loss - Amp Factor + Reading.
 2. The emission levels that are 20dB below the official limit are not reported.



No.6 Ke Feng Road,B1:ck 52,
 ShenZhen Science & Industry Park
 Noutou, ShenZhen, GuangDong, China
 Tel:+86-755-26639495-7
 Fax:+86-755-26632877
 Postcode:518057

Data: 11 File: D:\2007 Report\T\TP-Link\W8920G\HRE\ACS7Q666.EMI (42)

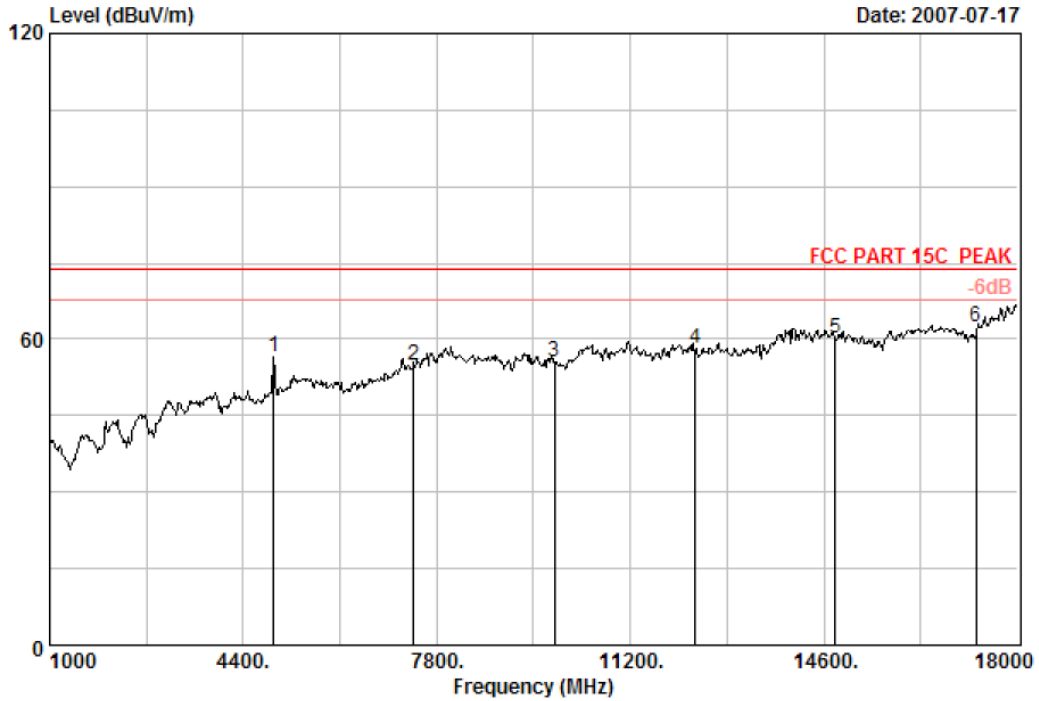

Site no. : Audix No.1 Chamber Data no. : 11
 Dis. / Ant. : 3m 3115 FACTOR Ant. pol. : HORIZONTAL
 Limit : FCC PART 15C PEAK
 Env. / Ins. : 23°C/54% Engineer : Jamy
 EUT : 108M Wireless ADSL2+Router M/N:TD-W8920G
 Power Rating : DC 12V From Adapter 120V/60Hz
 Test Mode : IEEE 802.11b TX in CH11 2462MHz

	Freq. (MHz)	Ant. Factor (dB/m)	Cable Amp		Emission			Margin (dB)	Remark
			Loss (dB)	Factor (dB)	Reading (dBuV)	Level (dBuV/m)	Limits (dBuV/m)		
1	4934.00	34.29	0.00	34.47	56.72	56.54	74.00	17.46	Peak
2	7401.00	37.66	0.00	34.48	51.74	54.92	74.00	19.08	Peak
3	9868.00	37.93	0.00	36.10	53.54	55.37	74.00	18.63	Peak
4	12335.00	39.41	0.00	36.29	54.89	58.01	74.00	15.99	Peak
5	14802.00	41.36	0.00	35.30	54.13	60.19	74.00	13.81	Peak
6	17269.00	41.96	0.00	34.89	55.56	62.63	74.00	11.37	Peak

Remarks: 1. Emission Level= Antenna Factor + Cable Loss - Amp Factor + Reading.
 2. The emission levels that are 20dB below the official limit are not reported.



No.6 Ke Feng Road,B1:ck 52,
 ShenZhen Science & Industry Park
 Noutou, ShenZhen, GuangDong, China
 Tel:+86-755-26639495-7
 Fax:+86-755-26632877
 Postcode:518057

Data: 12 File: D:\2007 Report\TTP-Link\W8920G\HRE\ACS7Q666.EMI (42)

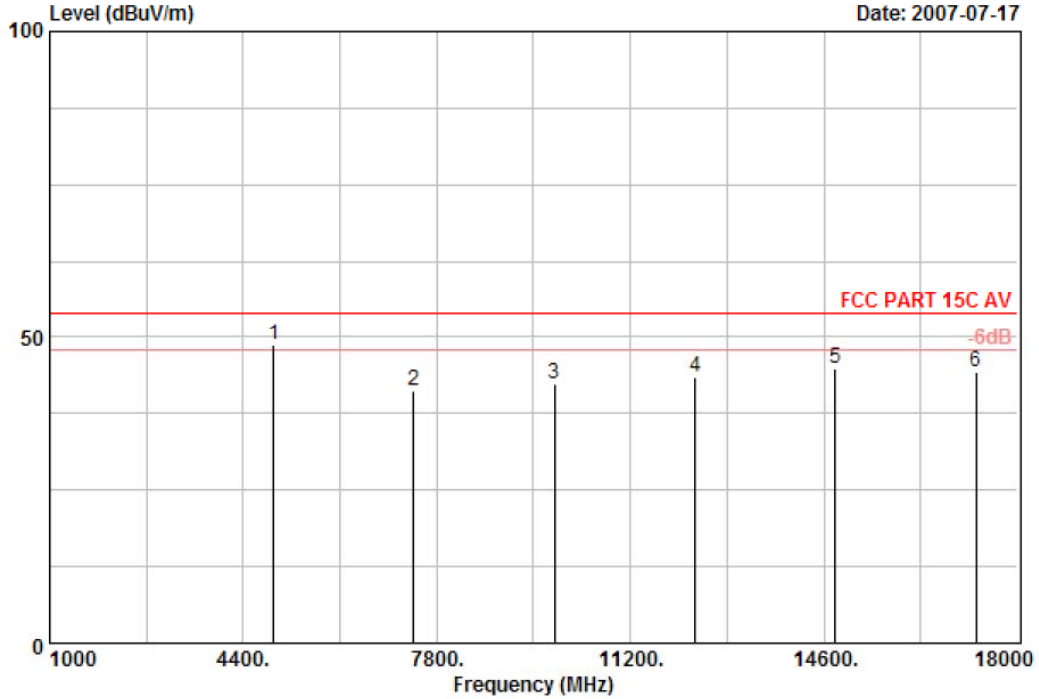

Site no. : Audix No.1 Chamber Data no. : 12
 Dis. / Ant. : 3m 3115 FACTOR Ant. pol. : HORIZONTAL
 Limit : FCC PART 15C AV
 Env. / Ins. : 23°C/54% Engineer : Jamy
 EUT : 108M Wireless ADSL2+Router M/N:TD-W8920G
 Power Rating : DC 12V From Adapter 120V/60Hz
 Test Mode : IEEE 802.11b TX in CH11 2462MHz

	Freq. (MHz)	Ant. Factor (dB/m)	Cable Loss (dB)	Amp Factor (dB)	Emission		Limits (dBuV/m)	Margin (dB)	Remark
					Reading (dBuV)	Level (dBuV/m)			
1	4934.00	34.29	0.00	34.47	48.82	48.64	54.00	5.36	Average
2	7401.00	37.66	0.00	34.48	38.18	41.36	54.00	12.64	Average
3	9868.00	37.93	0.00	36.10	40.63	42.46	54.00	11.54	Average
4	12335.00	39.41	0.00	36.29	40.33	43.45	54.00	10.55	Average
5	14802.00	41.36	0.00	35.30	38.83	44.89	54.00	9.11	Average
6	17269.00	41.96	0.00	34.89	37.20	44.27	54.00	9.73	Average

Remarks: 1. Emission Level= Antenna Factor + Cable Loss - Amp Factor + Reading.
 2. The emission levels that are 20dB below the official limit are not reported.



No.6 Ke Feng Road,B1:ck 52,
ShenZhen Science & Industry Park
Noutou, ShenZhen, GuangDong, China
Tel:+86-755-26639495-7
Fax:+86-755-26632877
Postcode:518057

Data: 9 File: D:\2007 Report\T\TP-Link\W8920G\HRE\ACS7Q666.EMI (42)

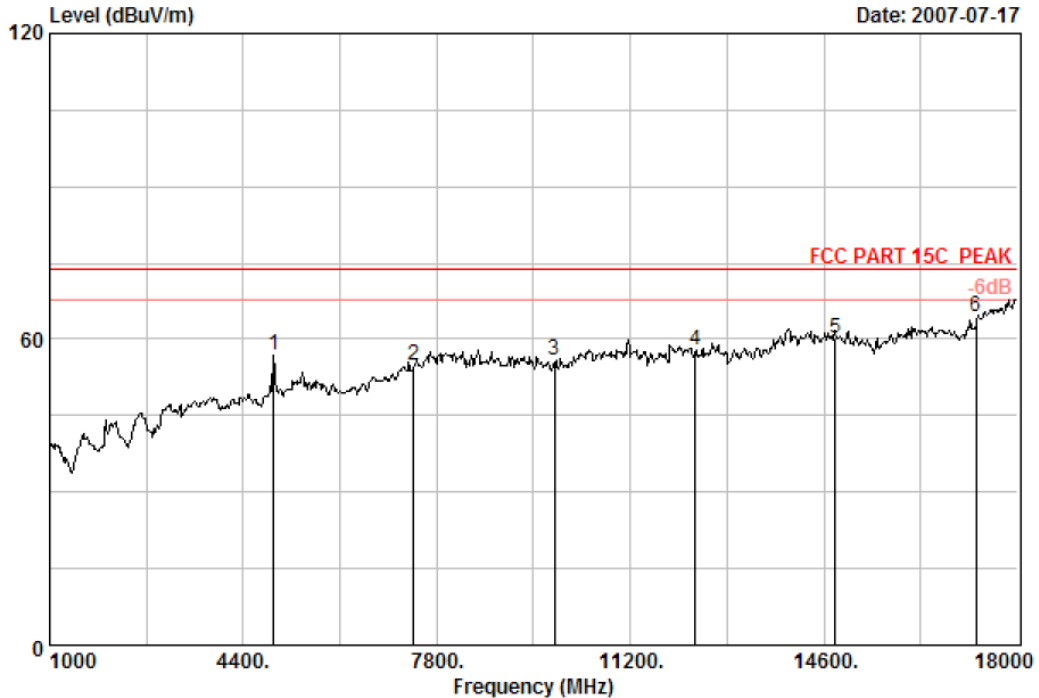

Site no. : Audix No.1 Chamber Data no. : 9
 Dis. / Ant. : 3m 3115 FACTOR Ant. pol. : VERTICAL
 Limit : FCC PART 15C PEAK
 Env. / Ins. : 23°C/54% Engineer : Jamy
 EUT : 108M Wireless ADSL2+Router M/N:TD-W8920G
 Power Rating : DC 12V From Adapter 120V/60Hz
 Test Mode : IEEE 802.11b TX in CH11 2462MHz

	Freq. (MHz)	Ant. Factor (dB/m)	Cable Amp		Emission		Limits (dBuV/m)	Margin (dB)	Remark
			Loss (dB)	Factor (dB)	Reading (dBuV)	Level (dBuV/m)			
1	4934.00	34.29	0.00	34.47	56.98	56.80	74.00	17.20	Peak
2	7401.00	37.66	0.00	34.48	51.48	54.66	74.00	19.34	Peak
3	9868.00	37.93	0.00	36.10	53.86	55.69	74.00	18.31	Peak
4	12335.00	39.41	0.00	36.29	54.80	57.92	74.00	16.08	Peak
5	14802.00	41.36	0.00	35.30	54.09	60.15	74.00	13.85	Peak
6	17269.00	41.96	0.00	34.89	57.49	64.56	74.00	9.44	Peak

Remarks: 1. Emission Level= Antenna Factor + Cable Loss - Amp Factor + Reading.
 2. The emission levels that are 20dB below the official limit are not reported.