

802.11ac-VHT40 Power Spectral Density – Ant 0

Channel 38 (5190MHz)

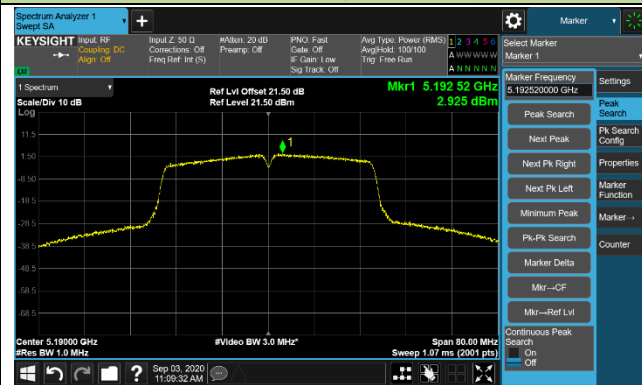

Channel 46 (5230MHz)

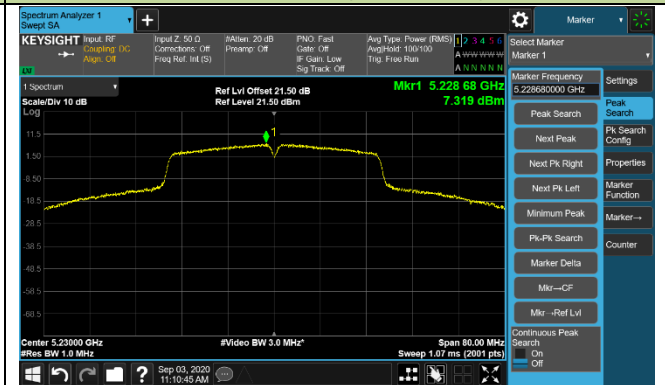

Channel 54 (5270MHz)

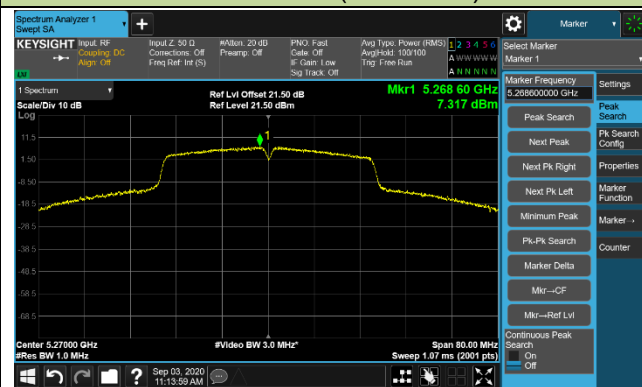

Channel 62 (5310MHz)

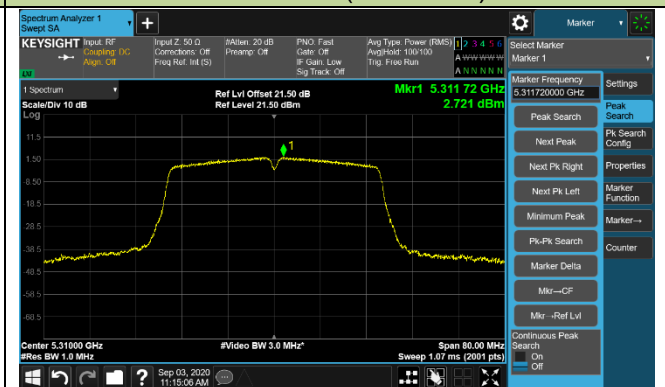

Channel 102 (5510MHz)

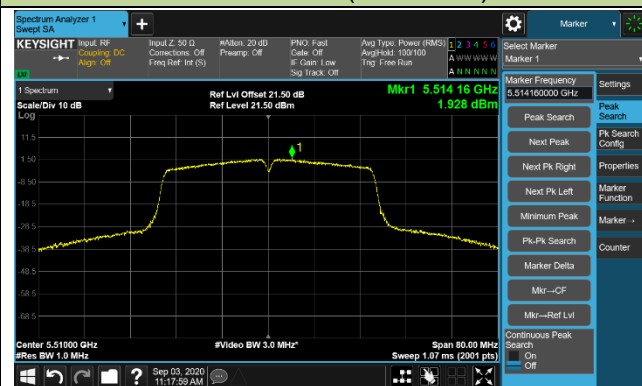

Channel 110 (5550MHz)

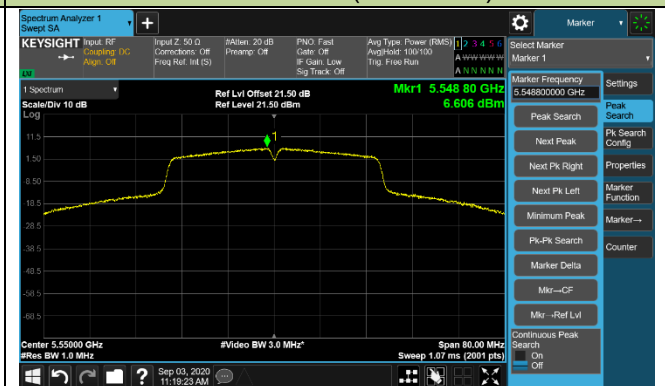

Channel 134 (5670MHz)



Channel 151 (5755MHz)

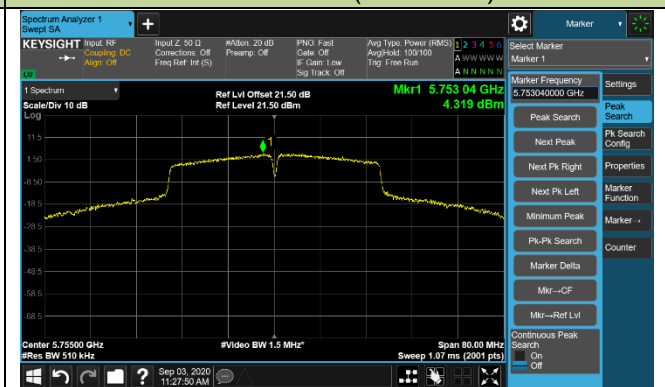

802.11ac-VHT40 Power Spectral Density – Ant 0

Channel 159 (5795MHz)

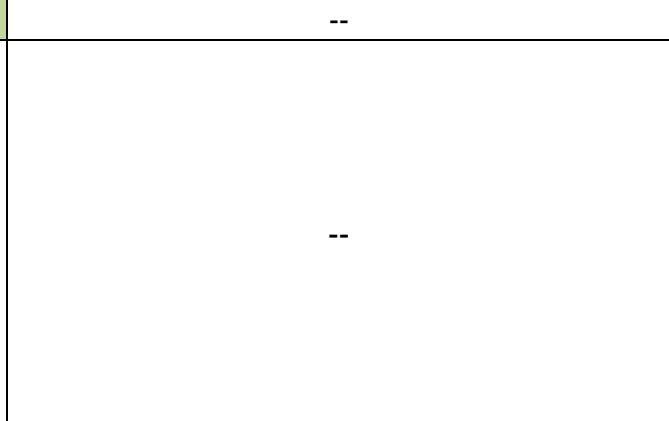
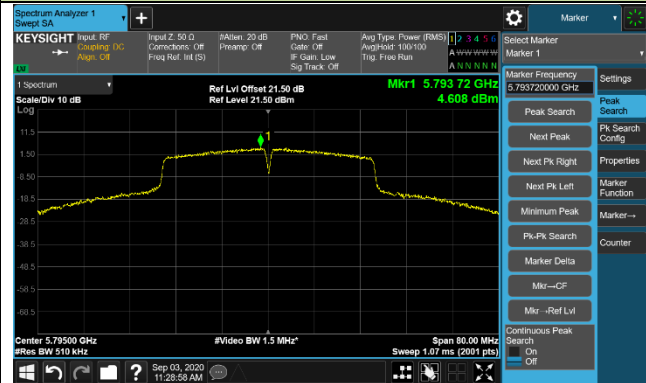

802.11ac-VHT80 Power Spectral Density – Ant 0

Channel 42 (5210MHz)

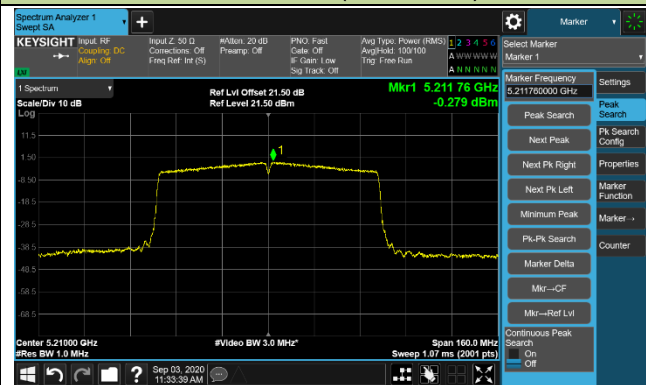

Channel 58 (5290MHz)

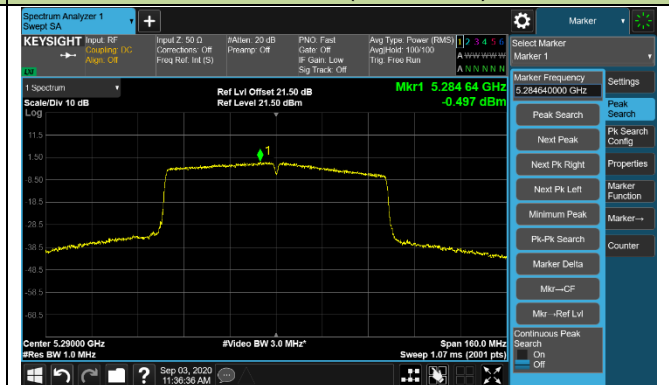

Channel 106 (5530MHz)

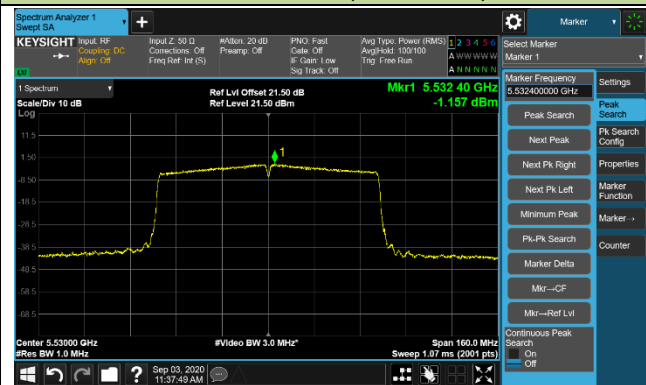

Channel 122 (5610MHz)

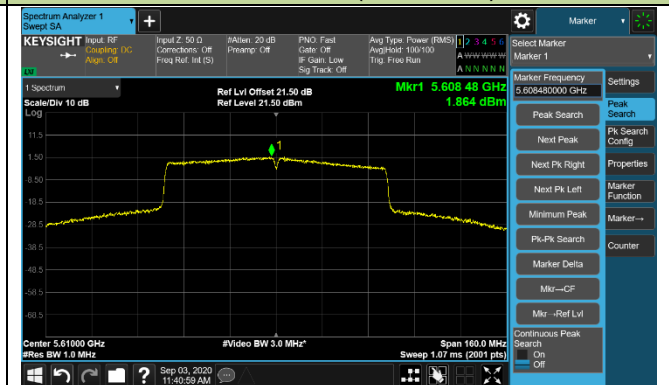

Channel 155 (5775MHz)

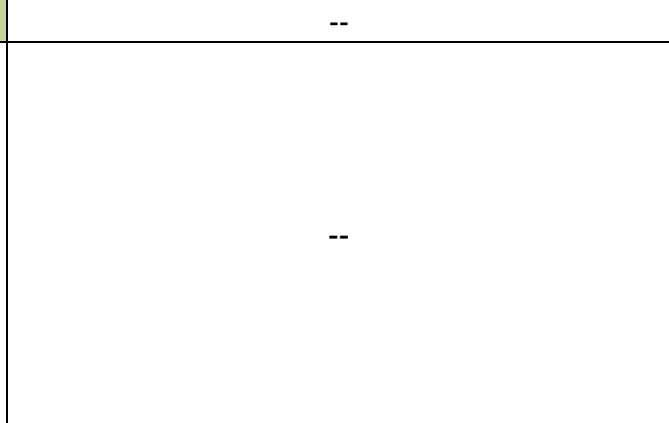
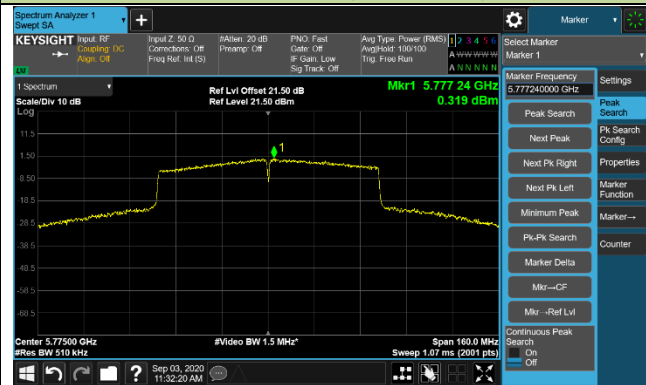

802.11a Power Spectral Density – Ant 1

Channel 36 (5180MHz)

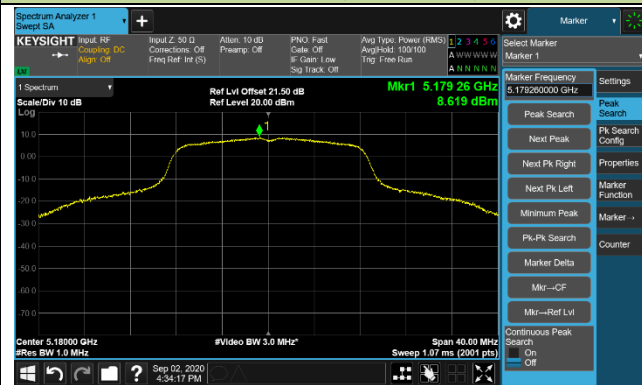

Channel 44 (5220MHz)

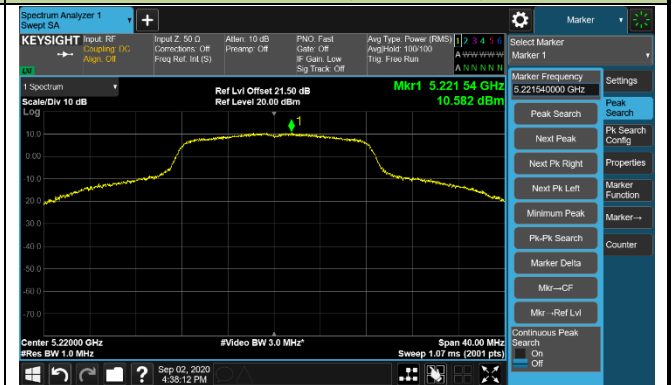

Channel 48 (5240MHz)

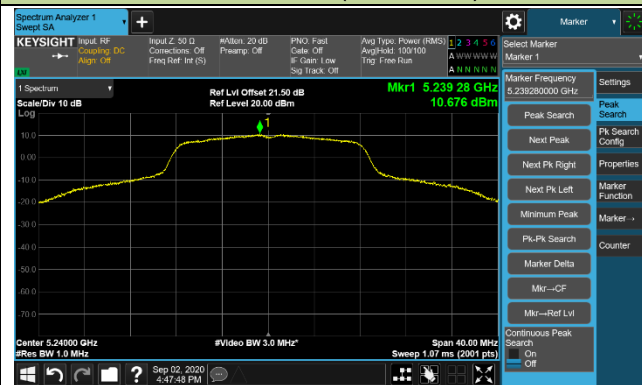

Channel 52 (5260MHz)

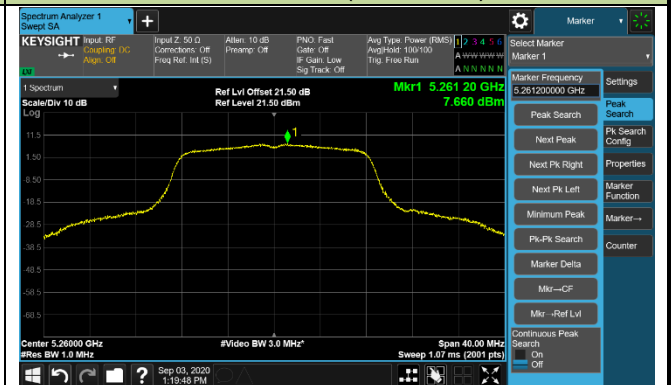

Channel 60 (5300MHz)



Channel 64 (5320MHz)



Channel 100 (5500MHz)



Channel 116 (5580MHz)



802.11a Power Spectral Density – Ant 1

Channel 140 (5700MHz)

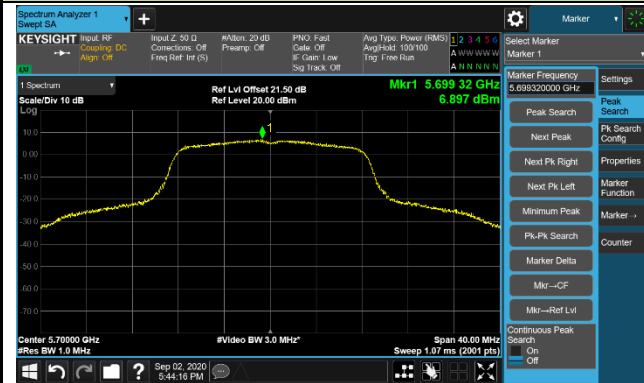

Channel 149 (5745MHz)

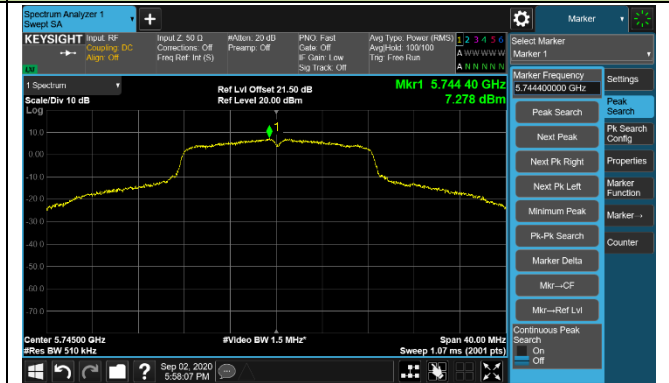

Channel 157 (5785MHz)



Channel 165 (5825MHz)



802.11ac-VHT20 Power Spectral Density – Ant 1

Channel 36 (5180MHz)

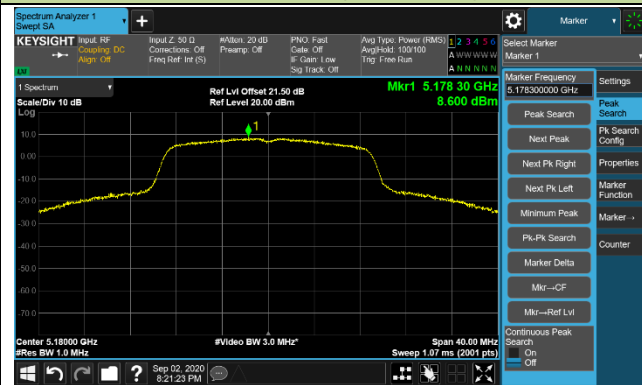

Channel 44 (5220MHz)

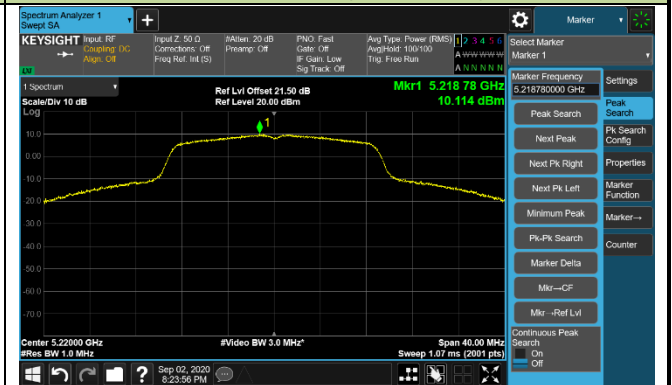

Channel 48 (5240MHz)

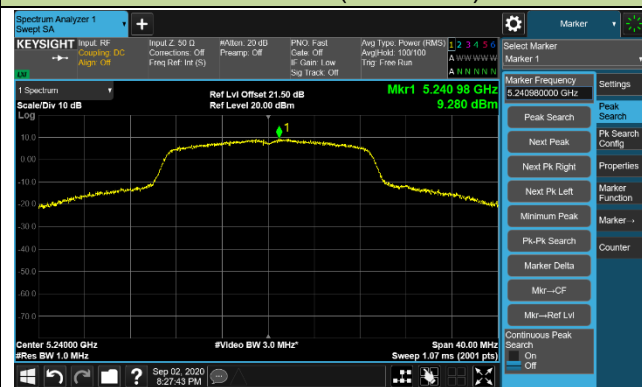

Channel 52 (5260MHz)

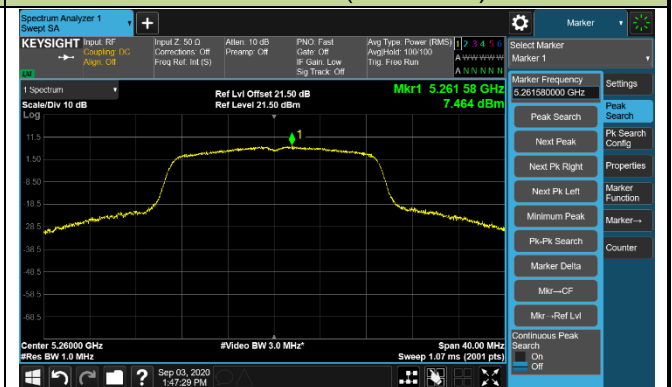

Channel 60 (5300MHz)

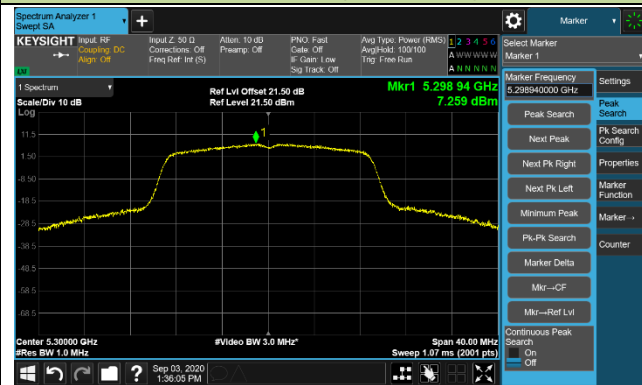

Channel 64 (5320MHz)

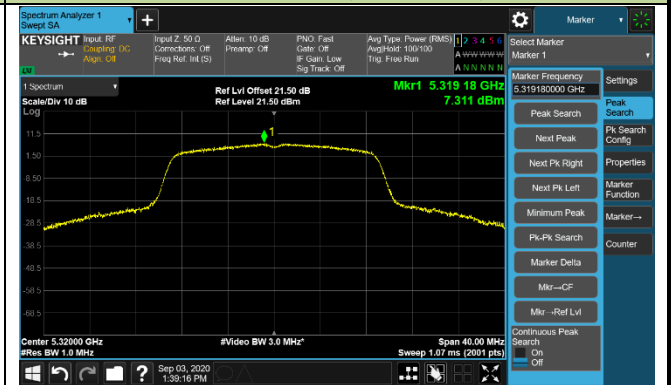

Channel 100 (5500MHz)

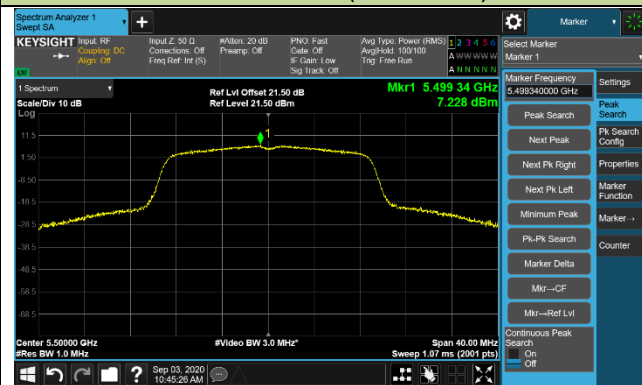

Channel 116 (5580MHz)

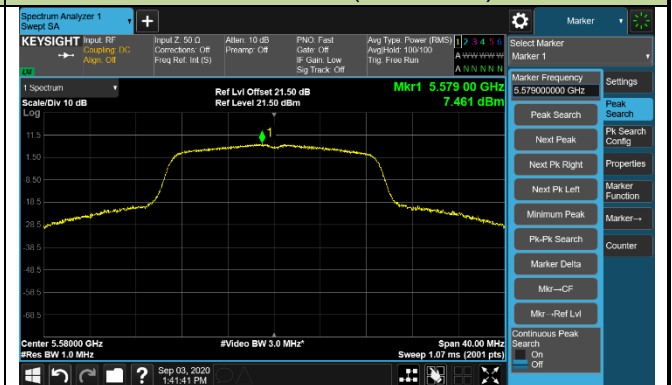

802.11ac-VHT20 Power Spectral Density – Ant 1

Channel 140 (5700MHz)



Channel 149 (5745MHz)

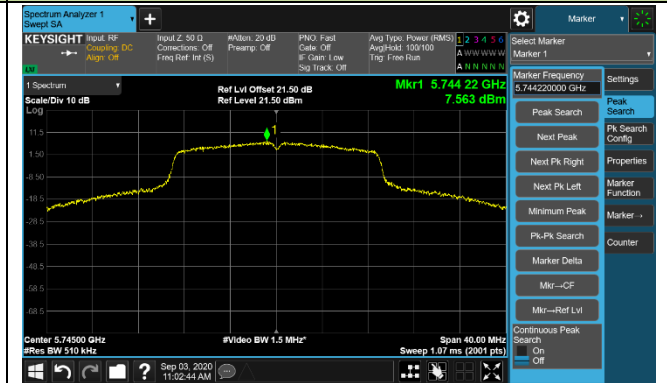

Channel 157 (5785MHz)

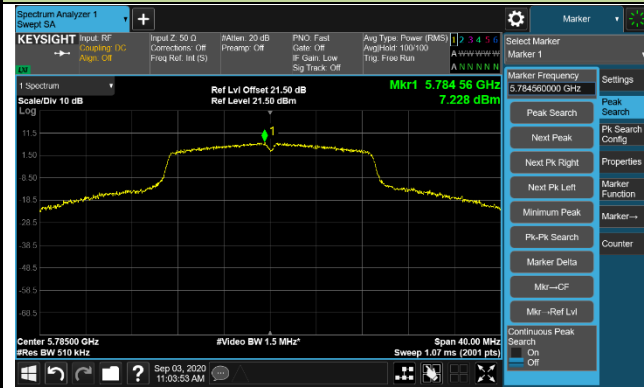

Channel 165 (5825MHz)

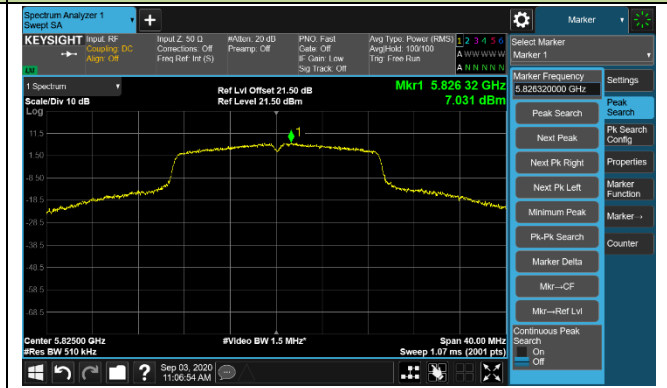

802.11ac-VHT40 Power Spectral Density – Ant 1

Channel 38 (5190MHz)

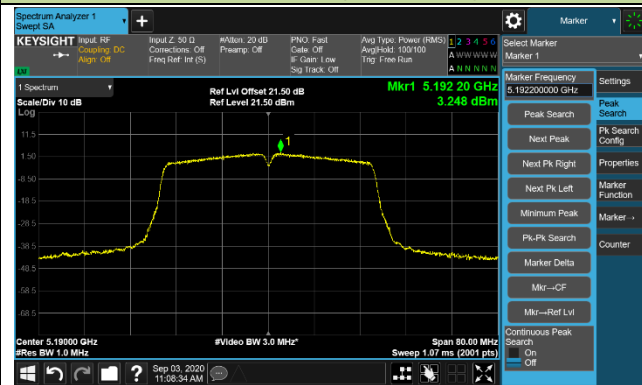

Channel 46 (5230MHz)

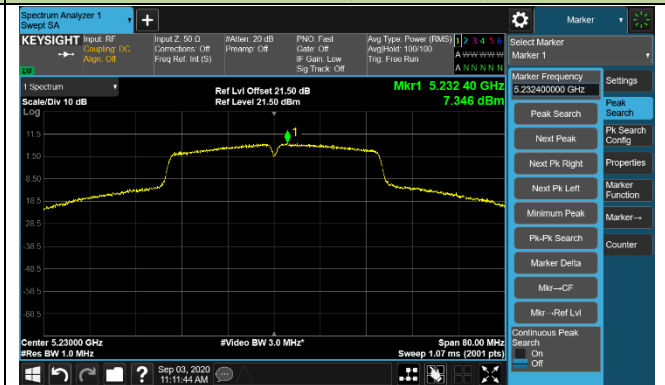

Channel 54 (5270MHz)

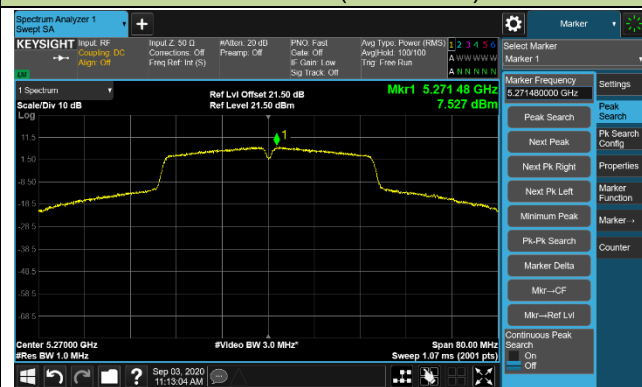

Channel 62 (5310MHz)

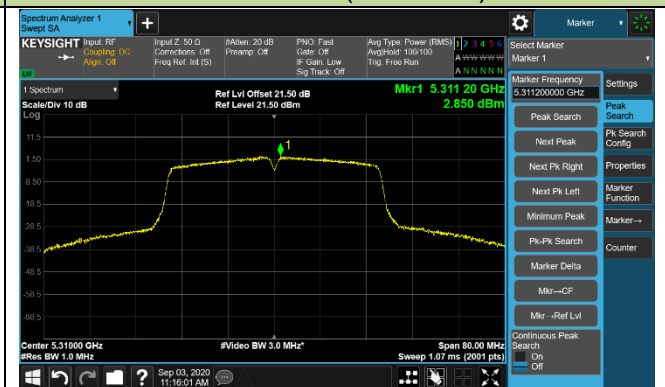

Channel 102 (5510MHz)

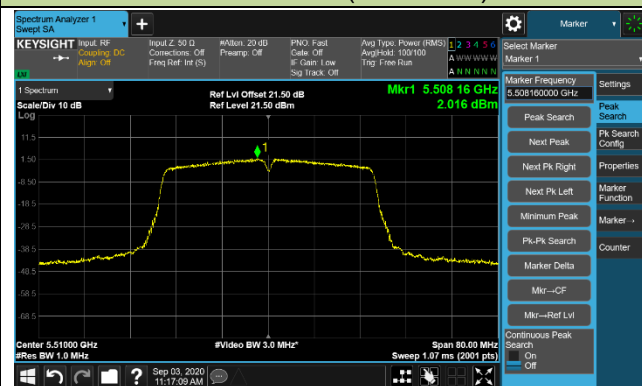

Channel 110 (5550MHz)

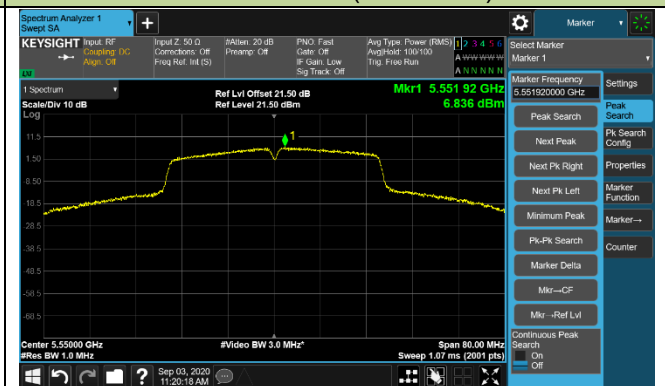

Channel 134 (5670MHz)



Channel 151 (5755MHz)

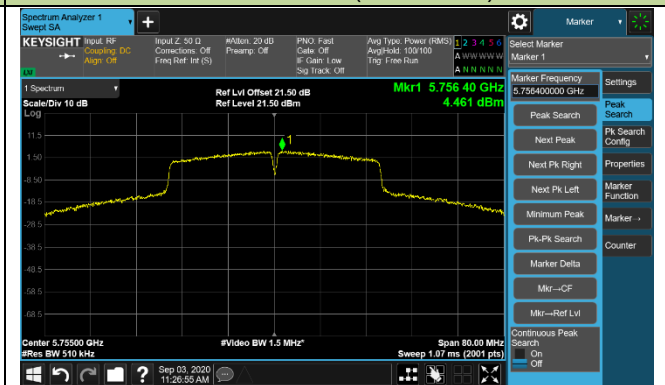

802.11ac-VHT40 Power Spectral Density – Ant 1

Channel 159 (5795MHz)

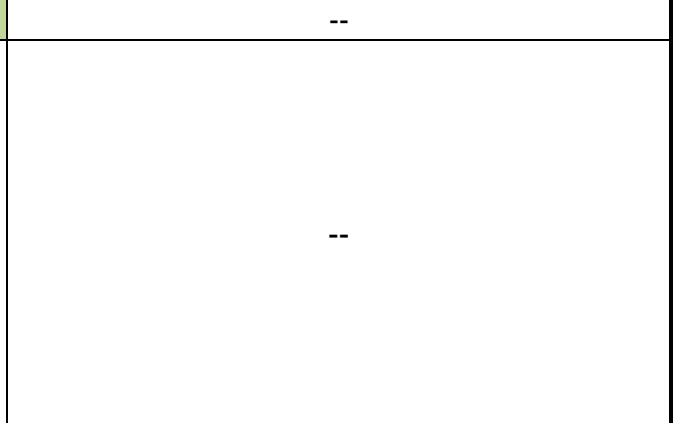
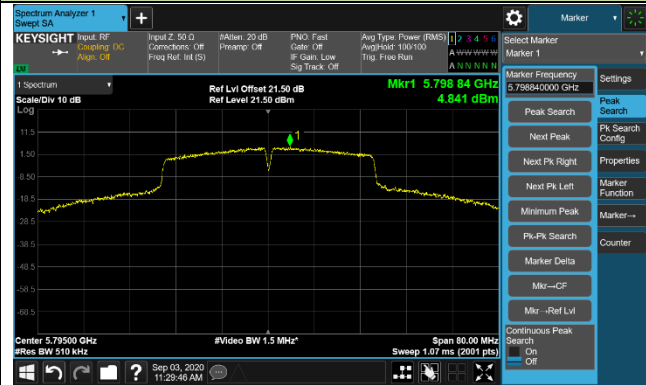

802.11ac-VHT80 Power Spectral Density – Ant 1

Channel 42 (5210MHz)

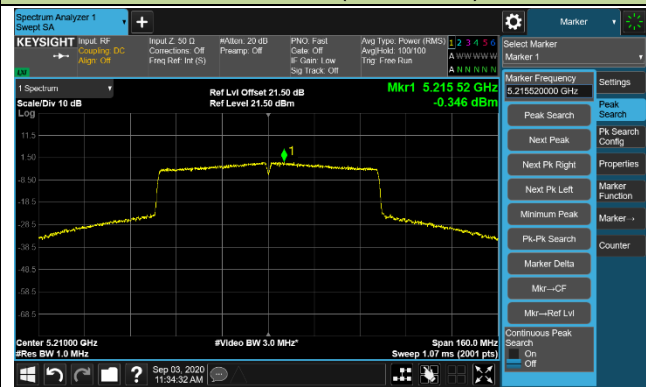

Channel 58 (5290MHz)

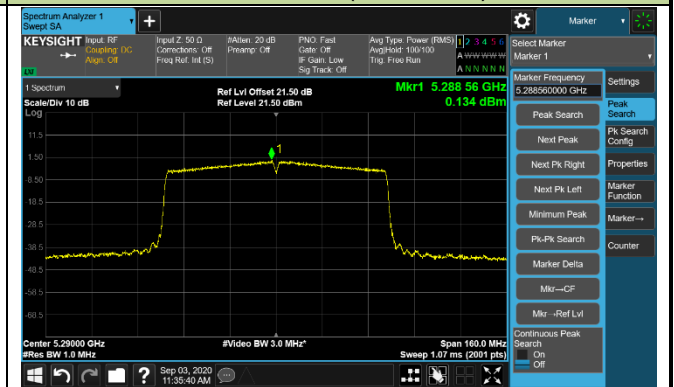

Channel 106 (5530MHz)



Channel 122 (5610MHz)

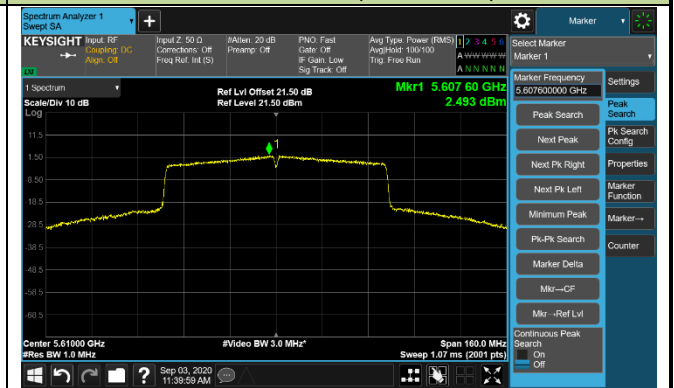

Channel 155 (5775MHz)

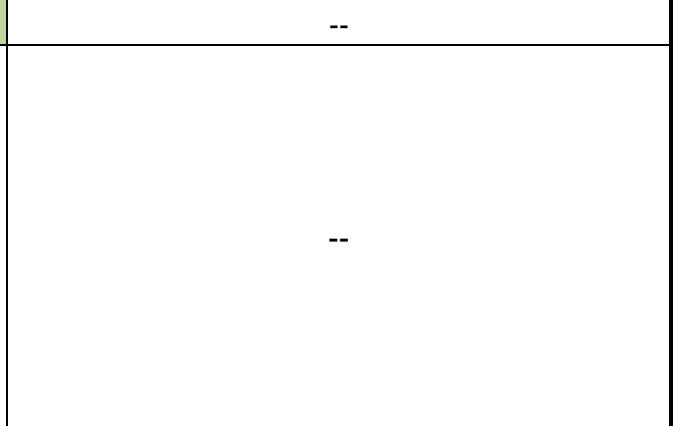
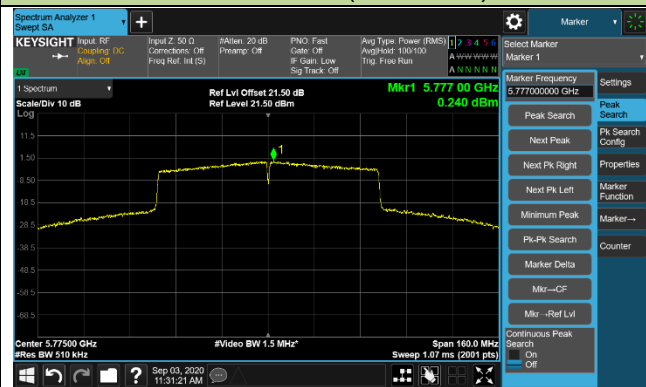

6.7. Frequency Stability Measurement

6.7.1. Test Limit

Manufacturers of U-NII devices are responsible for ensuring frequency stability such that an emission is maintained within the band of operation under all conditions of normal operation as specified in the user's manual.

6.7.2. Test Procedure Used

Frequency Stability Under Temperature Variations:

The equipment under test was connected to an external AC or DC power supply and input rated voltage. RF output was connected to a frequency counter or spectrum analyzer via feed through attenuators. The EUT was placed inside the temperature chamber. Set the spectrum analyzer RBW low enough to obtain the desired frequency resolution and measure EUT 20°C operating frequency as reference frequency. Turn EUT off and set the chamber temperature to highest. After the temperature stabilized for approximately 30 minutes recorded the frequency. Repeat step measure with 10°C decreased per stage until the lowest temperature reached.

Frequency Stability Under Voltage Variations:

Set chamber temperature to 20°C. Use a variable AC power supply / DC power source to power the EUT and set the voltage to rated voltage. Set the spectrum analyzer RBW low enough to obtain the desired frequency resolution and recorded the frequency.

Reduce the input voltage to specify extreme voltage variation ($\pm 15\%$) and endpoint, record the maximum frequency change. For hand-carried battery-powered equipment, primary supply voltage is reduced to the battery operating end point which shall be specified by the manufacturer.

6.7.3. Test Setup

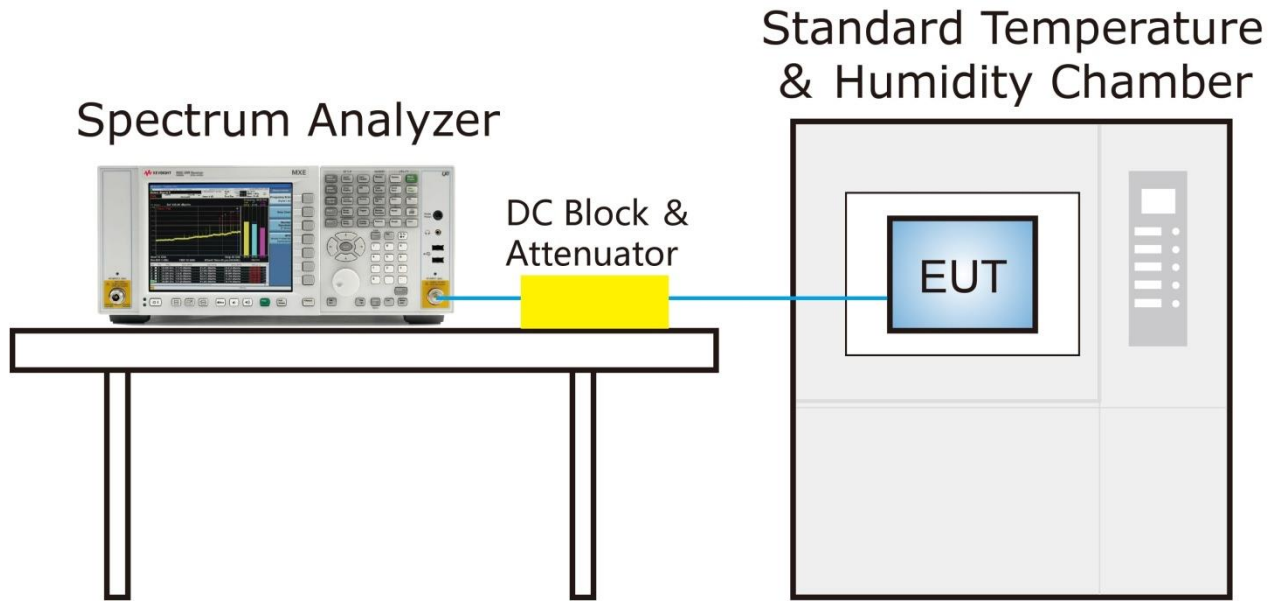

6.7.4. Test Result

Product	AC750 Wi-Fi Range Extender	Test Engineer	Amy Zhang
Test Site	TR3	Test Time	2020/09/11
Test Mode	5180MHz (Carrier Mode)		

Voltage (%)	Power (V _{DC})	Temp (°C)	Frequency Tolerance (ppm)			
			0 minutes	2 minutes	5 minutes	10 minutes
100%	120	0	0.00	0.26	-0.11	0.12
		+ 10	15.44	15.25	15.15	15.28
		+ 20 (Ref)	11.58	11.49	11.54	11.69
		+ 30	15.44	15.32	15.26	15.11
		+ 40	1.93	1.84	1.74	1.68
115%	138	+ 20	19.31	19.22	18.99	19.05
85%	102	+ 20	11.58	11.59	11.49	11.58

Note: Frequency Tolerance (ppm) = $\{[\text{Measured Frequency (MHz)} - \text{Declared Frequency (MHz)}] / \text{Declared Frequency (MHz)}\} * 10^6$.

6.8. Radiated Spurious Emission Measurement

6.8.1. Test Limit

All out of band emissions appearing in a restricted band as specified in Section 15.205 of the Title 47 CFR must not exceed the limits shown in Table per Section 15.209.

FCC Part 15 Subpart C Paragraph 15.209		
Frequency (MHz)	Field Strength ($\mu\text{V}/\text{m}$)	Measured Distance (m)
0.009 - 0.490	2400/F (kHz)	300
0.490 - 1.705	24000/F (kHz)	30
1.705 - 30	30	30
30 - 88	100	3
88 - 216	150	3
216 - 960	200	3
Above 960	500	3

6.8.2. Test Procedure Used

KDB 789033 D02v02r01- Section G

6.8.3. Test Setting

Table 1 - RBW as a function of frequency

Frequency	RBW
9 ~ 150 kHz	200 ~ 300 Hz
0.15 ~ 30 MHz	9 ~ 10 kHz
30 ~ 1000 MHz	100 ~ 120 kHz
> 1000 MHz	1 MHz

Quasi-Peak Measurements below 1GHz

1. Analyzer center frequency was set to the frequency of the radiated spurious emission of interest
2. Span was set greater than 1MHz
3. RBW = as specified in Table 1
4. Detector = CISPR quasi-peak
5. Sweep time = auto couple
6. Trace was allowed to stabilize

Peak Measurements above 1GHz

1. Analyzer center frequency was set to the frequency of the radiated spurious emission of interest
2. RBW = 1MHz
3. VBW = 3MHz
4. Detector = peak
5. Sweep time = auto couple
6. Trace mode = max hold
7. Trace was allowed to stabilize

Average Measurements above 1GHz (Method VB)

1. Analyzer center frequency was set to the frequency of the radiated spurious emission of interest
2. RBW = 1MHz
3. VBW; If the EUT is configured to transmit with duty cycle $\geq 98\%$, set VBW = 10Hz
If the EUT duty cycle is $< 98\%$, set VBW $\geq 1/T$. T is the minimum transmission duration
4. Detector = Peak
5. Sweep time = auto
6. Trace mode = max hold
7. Trace was allowed to stabilize

6.8.4. Test Setup

Below 1GHz Test Setup:

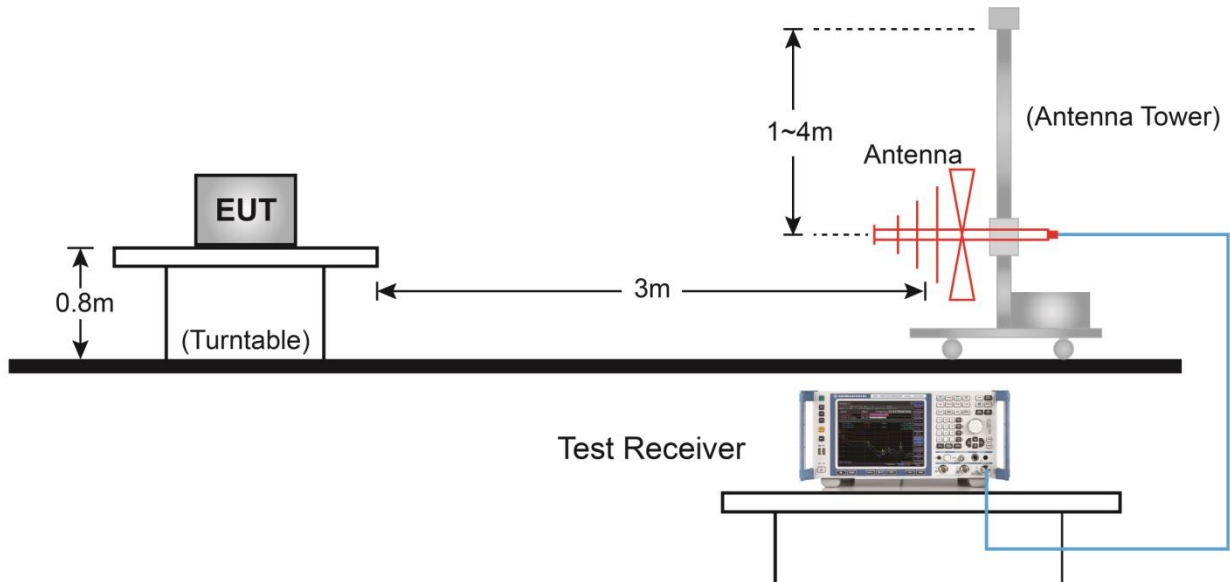

Above 1GHz Test Setup:

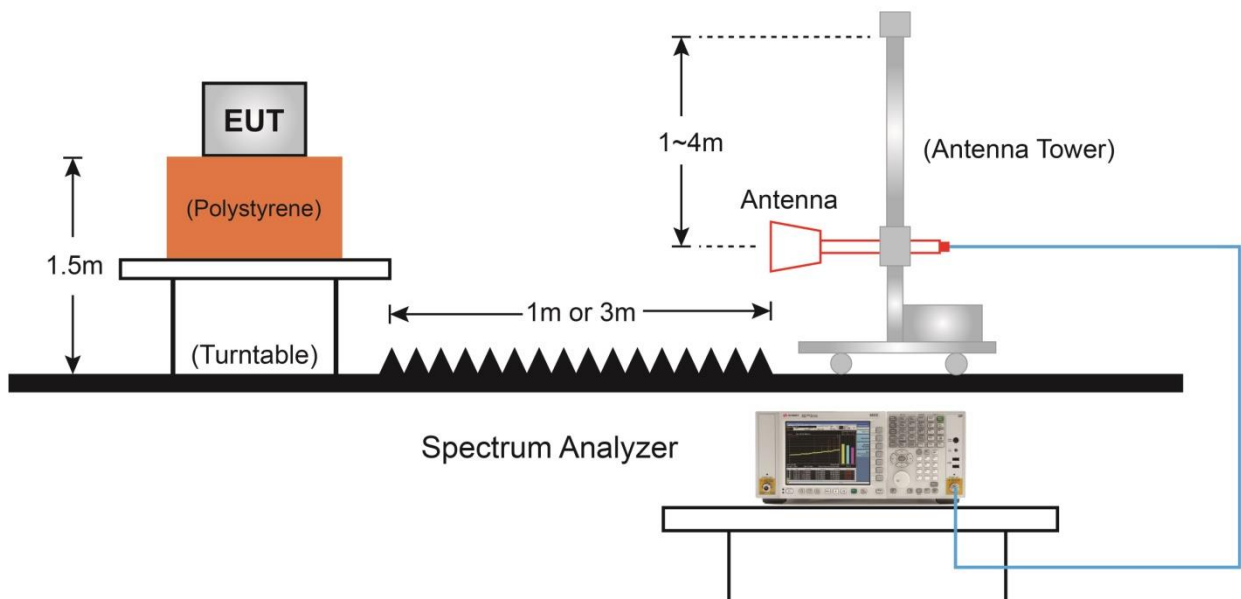

6.8.5. Test Result

Product	AC1200 Wi-Fi Range Extender	Test Engineer	Edgar Ma
Test Site	WZ-AC2	Test Date	2020/09/01
Test Mode	802.11a	Test Channel	36
Remark	1. Average measurement was not performed if peak level lower than average limit. 2. Other frequency was 20dB below limit line within 1-18GHz, there is not show in the report.		

Mark	Frequency (MHz)	Reading Level (dBμV)	Factor (dB)	Measure Level (dBμV/m)	Limit (dBμV/m)	Margin (dB)	Detector	Polarization
	7553.5	34.8	8.2	43.0	74.0	-31.0	Peak	Horizontal
	8259.0	32.2	8.2	40.4	74.0	-33.6	Peak	Horizontal
*	8811.5	31.4	9.9	41.3	68.2	-26.9	Peak	Horizontal
*	10358.5	36.4	12.6	49.0	68.2	-19.2	Peak	Horizontal
	7536.5	34.7	8.1	42.8	74.0	-31.2	Peak	Vertical
	8182.5	34.1	8.6	42.7	74.0	-31.3	Peak	Vertical
*	8726.5	34.0	9.6	43.5	68.2	-24.7	Peak	Vertical
*	10358.5	41.5	12.6	54.1	68.2	-14.1	Peak	Vertical

Note 1: "*" is not in restricted band, its limit is -27dBm/MHz. At a distance of 3 meters, the field strength limit in dBμV/m can be determined by adding a "conversion" factor of 95.2dB to the EIRP limit of -27dBm/MHz to obtain the limit for out of band spurious emissions.

Note 2: Measure Level (dBμV/m) = Reading Level (dBμV) + Factor (dB)

Factor (dB) = Cable Loss (dB) + Antenna Factor (dB/m) - Pre_Amplifier Gain (dB)

Product	AC1200 Wi-Fi Range Extender	Test Engineer	Edgar Ma
Test Site	WZ-AC2	Test Date	2020/09/01
Test Mode	802.11a	Test Channel	44
Remark	1. Average measurement was not performed if peak level lower than average limit. 2. Other frequency was 20dB below limit line within 1-18GHz, there is not show in the report.		

Mark	Frequency (MHz)	Reading Level (dBμV)	Factor (dB)	Measure Level (dBμV/m)	Limit (dBμV/m)	Margin (dB)	Detector	Polarization
	7562.0	34.3	8.1	42.4	74.0	-31.6	Peak	Horizontal
	8310.0	34.0	8.4	42.4	74.0	-31.6	Peak	Horizontal
*	8735.0	32.7	9.8	42.5	68.2	-25.7	Peak	Horizontal
*	10443.5	42.7	12.5	55.2	68.2	-13.0	Peak	Horizontal
	7485.5	34.0	8.3	42.3	74.0	-31.7	Peak	Vertical
	8259.0	33.6	8.2	41.8	74.0	-32.2	Peak	Vertical
*	8769.0	32.1	10.1	42.2	68.2	-26.0	Peak	Vertical
*	10443.5	46.5	12.5	59.0	68.2	-9.2	Peak	Vertical

Note 1: "*" is not in restricted band, its limit is -27dBm/MHz. At a distance of 3 meters, the field strength limit in dBμV/m can be determined by adding a "conversion" factor of 95.2dB to the EIRP limit of -27dBm/MHz to obtain the limit for out of band spurious emissions.

Note 2: Measure Level (dBμV/m) = Reading Level (dBμV) + Factor (dB)

Factor (dB) = Cable Loss (dB) + Antenna Factor (dB/m) - Pre_Amplifier Gain (dB)

Product	AC1200 Wi-Fi Range Extender	Test Engineer	Edgar Ma
Test Site	WZ-AC2	Test Date	2020/09/01
Test Mode	802.11a	Test Channel	48
Remark	1. Average measurement was not performed if peak level lower than average limit. 2. Other frequency was 20dB below limit line within 1-18GHz, there is not show in the report.		

Mark	Frequency (MHz)	Reading Level (dBμV)	Factor (dB)	Measure Level (dBμV/m)	Limit (dBμV/m)	Margin (dB)	Detector	Polarization
	7502.5	33.6	8.0	41.6	74.0	-32.4	Peak	Horizontal
	8225.0	33.7	8.1	41.9	74.0	-32.1	Peak	Horizontal
*	8769.0	31.9	10.1	42.0	68.2	-26.2	Peak	Horizontal
*	10469.0	39.9	12.7	52.6	68.2	-15.6	Peak	Horizontal
	7596.0	33.6	8.2	41.8	74.0	-32.2	Peak	Vertical
	8386.5	33.8	8.6	42.5	74.0	-31.5	Peak	Vertical
*	8769.0	32.5	10.1	42.6	68.2	-25.6	Peak	Vertical
*	10477.5	45.3	12.6	57.8	68.2	-10.4	Peak	Vertical

Note 1: "*" is not in restricted band, its limit is -27dBm/MHz. At a distance of 3 meters, the field strength limit in dBμV/m can be determined by adding a "conversion" factor of 95.2dB to the EIRP limit of -27dBm/MHz to obtain the limit for out of band spurious emissions.

Note 2: Measure Level (dBμV/m) = Reading Level (dBμV) + Factor (dB)

Factor (dB) = Cable Loss (dB) + Antenna Factor (dB/m) - Pre_Amplifier Gain (dB)

Product	AC1200 Wi-Fi Range Extender	Test Engineer	Edgar Ma
Test Site	WZ-AC2	Test Date	2020/09/01
Test Mode	802.11a	Test Channel	52
Remark	1. Average measurement was not performed if peak level lower than average limit. 2. Other frequency was 20dB below limit line within 1-18GHz, there is not show in the report.		

Mark	Frequency (MHz)	Reading Level (dB μ V)	Factor (dB)	Measure Level (dB μ V/m)	Limit (dB μ V/m)	Margin (dB)	Detector	Polarization
	7545.0	34.2	8.2	42.4	74.0	-31.6	Peak	Horizontal
	8165.5	34.8	8.5	43.3	74.0	-30.7	Peak	Horizontal
*	8769.0	33.5	10.1	43.6	68.2	-24.6	Peak	Horizontal
*	10520.0	42.7	12.7	55.4	68.2	-12.8	Peak	Horizontal
	7562.0	33.9	8.1	42.0	74.0	-32.0	Peak	Vertical
	8114.5	34.5	9.0	43.5	74.0	-30.5	Peak	Vertical
*	8837.0	34.0	9.8	43.8	68.2	-24.4	Peak	Vertical
*	10520.0	44.9	12.7	57.7	68.2	-10.5	Peak	Vertical

Note 1: "*" is not in restricted band, its limit is -27dBm/MHz. At a distance of 3 meters, the field strength limit in dB μ V/m can be determined by adding a "conversion" factor of 95.2dB to the EIRP limit of -27dBm/MHz to obtain the limit for out of band spurious emissions.

Note 2: Measure Level (dB μ V/m) = Reading Level (dB μ V) + Factor (dB)

Factor (dB) = Cable Loss (dB) + Antenna Factor (dB/m) - Pre_Amplifier Gain (dB)

Product	AC1200 Wi-Fi Range Extender	Test Engineer	Edgar Ma
Test Site	WZ-AC2	Test Date	2020/09/01
Test Mode	802.11a	Test Channel	60
Remark	1. Average measurement was not performed if peak level lower than average limit. 2. Other frequency was 20dB below limit line within 1-18GHz, there is not show in the report.		

Mark	Frequency (MHz)	Reading Level (dB μ V)	Factor (dB)	Measure Level (dB μ V/m)	Limit (dB μ V/m)	Margin (dB)	Detector	Polarization
	7409.0	31.6	8.2	39.8	74.0	-34.2	Peak	Horizontal
	8199.5	33.9	8.4	42.3	74.0	-31.7	Peak	Horizontal
*	8777.5	33.1	10.0	43.1	68.2	-25.1	Peak	Horizontal
*	10596.5	40.1	12.8	52.9	68.2	-15.3	Peak	Horizontal
	7434.5	32.2	8.2	40.5	74.0	-33.5	Peak	Vertical
	8233.5	34.6	8.3	42.9	74.0	-31.1	Peak	Vertical
*	8531.0	35.4	8.9	44.4	68.2	-23.8	Peak	Vertical
*	10596.5	44.2	12.8	57.0	68.2	-11.2	Peak	Vertical

Note 1: "*" is not in restricted band, its limit is -27dBm/MHz. At a distance of 3 meters, the field strength limit in dB μ V/m can be determined by adding a "conversion" factor of 95.2dB to the EIRP limit of -27dBm/MHz to obtain the limit for out of band spurious emissions.

Note 2: Measure Level (dB μ V/m) = Reading Level (dB μ V) + Factor (dB)

Factor (dB) = Cable Loss (dB) + Antenna Factor (dB/m) - Pre_Amplifier Gain (dB)

Product	AC1200 Wi-Fi Range Extender	Test Engineer	Edgar Ma
Test Site	WZ-AC2	Test Date	2020/09/01
Test Mode	802.11a	Test Channel	64
Remark	1. Average measurement was not performed if peak level lower than average limit. 2. Other frequency was 20dB below limit line within 1-18GHz, there is not show in the report.		

Mark	Frequency (MHz)	Reading Level (dB μ V)	Factor (dB)	Measure Level (dB μ V/m)	Limit (dB μ V/m)	Margin (dB)	Detector	Polarization
	7307.0	34.0	8.1	42.1	74.0	-31.9	Peak	Horizontal
	8233.5	34.9	8.3	43.2	74.0	-30.8	Peak	Horizontal
*	9253.5	33.8	11.0	44.9	68.2	-23.3	Peak	Horizontal
*	9857.0	33.7	10.9	44.6	68.2	-23.6	Peak	Horizontal
	8123.0	34.1	8.9	43.0	74.0	-31.0	Peak	Vertical
	10639.0	37.4	13.4	50.8	74.0	-23.2	Peak	Vertical
*	12917.0	32.3	15.9	48.1	68.2	-20.1	Peak	Vertical
*	15178.0	36.1	18.2	54.3	68.2	-13.9	Peak	Vertical

Note 1: "*" is not in restricted band, its limit is -27dBm/MHz. At a distance of 3 meters, the field strength limit in dB μ V/m can be determined by adding a "conversion" factor of 95.2dB to the EIRP limit of -27dBm/MHz to obtain the limit for out of band spurious emissions.

Note 2: Measure Level (dB μ V/m) = Reading Level (dB μ V) + Factor (dB)

Factor (dB) = Cable Loss (dB) + Antenna Factor (dB/m) - Pre_Amplifier Gain (dB)

Product	AC1200 Wi-Fi Range Extender	Test Engineer	Edgar Ma
Test Site	WZ-AC2	Test Date	2020/09/01
Test Mode	802.11a	Test Channel	100
Remark	1. Average measurement was not performed if peak level lower than average limit. 2. Other frequency was 20dB below limit line within 1-18GHz, there is not show in the report.		

Mark	Frequency (MHz)	Reading Level (dB μ V)	Factor (dB)	Measure Level (dB μ V/m)	Limit (dB μ V/m)	Margin (dB)	Detector	Polarization
	7443.0	33.7	8.3	42.0	74.0	-32.0	Peak	Horizontal
	8242.0	33.4	8.5	41.9	74.0	-32.1	Peak	Horizontal
*	8803.0	35.7	10.0	45.8	68.2	-22.4	Peak	Horizontal
*	10469.0	33.8	12.7	46.5	68.2	-21.7	Peak	Horizontal
	7443.0	32.6	8.3	40.9	74.0	-33.1	Peak	Vertical
	8199.5	32.8	8.4	41.2	74.0	-32.8	Peak	Vertical
*	8803.0	33.8	10.0	43.8	68.2	-24.4	Peak	Vertical
*	9976.0	34.3	11.4	45.7	68.2	-22.5	Peak	Vertical

Note 1: "*" is not in restricted band, its limit is -27dBm/MHz. At a distance of 3 meters, the field strength limit in dB μ V/m can be determined by adding a "conversion" factor of 95.2dB to the EIRP limit of -27dBm/MHz to obtain the limit for out of band spurious emissions.

Note 2: Measure Level (dB μ V/m) = Reading Level (dB μ V) + Factor (dB)

Factor (dB) = Cable Loss (dB) + Antenna Factor (dB/m) - Pre_Amplifier Gain (dB)

Product	AC1200 Wi-Fi Range Extender	Test Engineer	Edgar Ma
Test Site	WZ-AC2	Test Date	2020/09/01
Test Mode	802.11a	Test Channel	116
Remark	1. Average measurement was not performed if peak level lower than average limit. 2. Other frequency was 20dB below limit line within 1-18GHz, there is not show in the report.		

Mark	Frequency (MHz)	Reading Level (dBμV)	Factor (dB)	Measure Level (dBμV/m)	Limit (dBμV/m)	Margin (dB)	Detector	Polarization
	7460.0	33.4	8.3	41.6	74.0	-32.4	Peak	Horizontal
	8174.0	34.7	8.6	43.3	74.0	-30.7	Peak	Horizontal
*	8956.0	36.9	9.9	46.8	68.2	-21.4	Peak	Horizontal
*	10528.5	34.1	12.8	46.8	68.2	-21.4	Peak	Horizontal
	7553.5	33.8	8.2	42.0	74.0	-32.0	Peak	Vertical
*	7970.0	33.9	8.4	42.3	68.2	-25.9	Peak	Vertical
*	8777.5	33.6	10.0	43.6	68.2	-24.6	Peak	Vertical
	11200.9	38.2	15.1	53.3	74.0	-20.7	Peak	Vertical
	11200.9	33.4	14.9	48.3	54.0	-5.7	Average	Vertical

Note 1: "*" is not in restricted band, its limit is -27dBm/MHz. At a distance of 3 meters, the field strength limit in dBμV/m can be determined by adding a "conversion" factor of 95.2dB to the EIRP limit of -27dBm/MHz to obtain the limit for out of band spurious emissions.

Note 2: Measure Level (dBμV/m) = Reading Level (dBμV) + Factor (dB)

Factor (dB) = Cable Loss (dB) + Antenna Factor (dB/m) - Pre_Amplifier Gain (dB)

Product	AC1200 Wi-Fi Range Extender	Test Engineer	Edgar Ma
Test Site	WZ-AC2	Test Date	2020/09/01
Test Mode	802.11a	Test Channel	140
Remark	1. Average measurement was not performed if peak level lower than average limit. 2. Other frequency was 20dB below limit line within 1-18GHz, there is not show in the report.		

Mark	Frequency (MHz)	Reading Level (dB μ V)	Factor (dB)	Measure Level (dB μ V/m)	Limit (dB μ V/m)	Margin (dB)	Detector	Polarization
	7587.5	33.4	8.3	41.7	74.0	-32.3	Peak	Horizontal
	8140.0	33.9	8.7	42.5	74.0	-31.5	Peak	Horizontal
*	8888.0	34.2	10.0	44.3	68.2	-23.9	Peak	Horizontal
*	10571.0	33.9	13.1	47.0	68.2	-21.2	Peak	Horizontal
	7664.0	33.5	7.9	41.4	74.0	-32.6	Peak	Vertical
	8412.0	33.3	8.8	42.1	74.0	-31.9	Peak	Vertical
*	8752.0	33.3	10.1	43.3	68.2	-24.9	Peak	Vertical
*	10511.5	32.9	12.7	45.6	68.2	-22.6	Peak	Vertical

Note 1: "*" is not in restricted band, its limit is -27dBm/MHz. At a distance of 3 meters, the field strength limit in dB μ V/m can be determined by adding a "conversion" factor of 95.2dB to the EIRP limit of -27dBm/MHz to obtain the limit for out of band spurious emissions.

Note 2: Measure Level (dB μ V/m) = Reading Level (dB μ V) + Factor (dB)

Factor (dB) = Cable Loss (dB) + Antenna Factor (dB/m) - Pre_Amplifier Gain (dB)

Product	AC1200 Wi-Fi Range Extender	Test Engineer	Edgar Ma
Test Site	WZ-AC2	Test Date	2020/09/01
Test Mode	802.11a	Test Channel	149
Remark	1. Average measurement was not performed if peak level lower than average limit. 2. Other frequency was 20dB below limit line within 1-18GHz, there is not show in the report.		

Mark	Frequency (MHz)	Reading Level (dB μ V)	Factor (dB)	Measure Level (dB μ V/m)	Limit (dB μ V/m)	Margin (dB)	Detector	Polarization
	7596.0	34.4	8.2	42.6	74.0	-31.4	Peak	Horizontal
	11489.0	36.7	15.7	52.5	74.0	-21.5	Peak	Horizontal
*	12976.5	32.1	16.2	48.3	68.2	-19.9	Peak	Horizontal
*	15127.0	33.7	17.3	51.0	68.2	-17.2	Peak	Horizontal
	7485.5	33.9	8.3	42.2	74.0	-31.8	Peak	Vertical
	11488.1	34.4	15.7	50.1	54.0	-3.9	Average	Vertical
	11488.1	37.7	15.7	53.4	74.0	-20.6	Peak	Vertical
*	13053.0	32.4	16.7	49.2	68.2	-19.0	Peak	Vertical
*	14761.5	32.6	19.8	52.4	68.2	-15.8	Peak	Vertical

Note 1: "*" is not in restricted band, its limit is -27dBm/MHz. At a distance of 3 meters, the field strength limit in dB μ V/m can be determined by adding a "conversion" factor of 95.2dB to the EIRP limit of -27dBm/MHz to obtain the limit for out of band spurious emissions.

Note 2: Measure Level (dB μ V/m) = Reading Level (dB μ V) + Factor (dB)

Factor (dB) = Cable Loss (dB) + Antenna Factor (dB/m) - Pre_Amplifier Gain (dB)

Product	AC1200 Wi-Fi Range Extender	Test Engineer	Edgar Ma
Test Site	WZ-AC2	Test Date	2020/09/01
Test Mode	802.11a	Test Channel	157
Remark	1. Average measurement was not performed if peak level lower than average limit. 2. Other frequency was 20dB below limit line within 1-18GHz, there is not show in the report.		

Mark	Frequency (MHz)	Reading Level (dBμV)	Factor (dB)	Measure Level (dBμV/m)	Limit (dBμV/m)	Margin (dB)	Detector	Polarization
	8106.0	33.6	9.1	42.7	74.0	-31.3	Peak	Horizontal
	11574.0	35.9	16.1	51.9	74.0	-22.1	Peak	Horizontal
*	12968.0	31.9	16.5	48.3	68.2	-19.9	Peak	Horizontal
*	15178.0	33.1	18.2	51.3	68.2	-16.9	Peak	Horizontal
	7494.0	33.7	8.2	41.9	74.0	-32.1	Peak	Vertical
	11582.0	31.7	16.4	48.1	54.0	-5.9	Average	Vertical
	11582.0	38.6	16.4	55.0	74.0	-19.0	Peak	Vertical
*	12891.5	30.7	15.4	46.1	68.2	-22.1	Peak	Vertical
*	14965.5	30.5	17.7	48.2	68.2	-20.0	Peak	Vertical

Note 1: "*" is not in restricted band, its limit is -27dBm/MHz. At a distance of 3 meters, the field strength limit in dBμV/m can be determined by adding a "conversion" factor of 95.2dB to the EIRP limit of -27dBm/MHz to obtain the limit for out of band spurious emissions.

Note 2: Measure Level (dBμV/m) = Reading Level (dBμV) + Factor (dB)

Factor (dB) = Cable Loss (dB) + Antenna Factor (dB/m) - Pre_Amplifier Gain (dB)

Product	AC1200 Wi-Fi Range Extender	Test Engineer	Edgar Ma
Test Site	WZ-AC2	Test Date	2020/09/01
Test Mode	802.11a	Test Channel	165
Remark	1. Average measurement was not performed if peak level lower than average limit. 2. Other frequency was 20dB below limit line within 1-18GHz, there is not show in the report.		

Mark	Frequency (MHz)	Reading Level (dB μ V)	Factor (dB)	Measure Level (dB μ V/m)	Limit (dB μ V/m)	Margin (dB)	Detector	Polarization
	8293.0	32.4	8.4	40.8	74.0	-33.2	Peak	Horizontal
	11642.5	37.5	16.5	53.9	74.0	-20.1	Peak	Horizontal
	11642.5	31.8	16.4	48.3	54.0	-5.8	Average	Horizontal
*	12959.5	30.6	16.5	47.1	68.2	-21.1	Peak	Horizontal
*	15280.0	32.3	18.2	50.5	68.2	-17.7	Peak	Horizontal
	8191.0	34.0	8.5	42.6	74.0	-31.4	Peak	Vertical
	11650.5	42.5	15.9	58.3	74.0	-15.7	Peak	Vertical
	11650.5	32.7	15.9	48.6	54.0	-5.4	Average	Vertical
*	13512.0	31.5	19.5	51.0	68.2	-17.2	Peak	Vertical
*	15161.0	33.4	17.1	50.5	68.2	-17.7	Peak	Vertical

Note 1: "*" is not in restricted band, its limit is -27dBm/MHz. At a distance of 3 meters, the field strength limit in dB μ V/m can be determined by adding a "conversion" factor of 95.2dB to the EIRP limit of -27dBm/MHz to obtain the limit for out of band spurious emissions.

Note 2: Measure Level (dB μ V/m) = Reading Level (dB μ V) + Factor (dB)

Factor (dB) = Cable Loss (dB) + Antenna Factor (dB/m) - Pre_Amplifier Gain (dB)

Product	AC1200 Wi-Fi Range Extender	Test Engineer	Edgar Ma
Test Site	WZ-AC2	Test Date	2020/09/01
Test Mode	802.11ac-VHT20	Test Channel	36
Remark	1. Average measurement was not performed if peak level lower than average limit. 2. Other frequency was 20dB below limit line within 1-18GHz, there is not show in the report.		

Mark	Frequency (MHz)	Reading Level (dBμV)	Factor (dB)	Measure Level (dBμV/m)	Limit (dBμV/m)	Margin (dB)	Detector	Polarization
	7630.0	33.9	8.1	42.1	74.0	-31.9	Peak	Horizontal
	8174.0	33.2	8.6	41.8	74.0	-32.2	Peak	Horizontal
*	8684.0	33.0	9.6	42.6	68.2	-25.6	Peak	Horizontal
*	10358.5	38.5	12.6	51.2	68.2	-17.0	Peak	Horizontal
	7460.0	33.7	8.3	42.0	74.0	-32.0	Peak	Vertical
	8216.5	33.5	8.2	41.7	74.0	-32.3	Peak	Vertical
*	8769.0	31.5	10.1	41.6	68.2	-26.6	Peak	Vertical
*	10358.5	41.1	12.6	53.7	68.2	-14.5	Peak	Vertical

Note 1: "*" is not in restricted band, its limit is -27dBm/MHz. At a distance of 3 meters, the field strength limit in dBμV/m can be determined by adding a "conversion" factor of 95.2dB to the EIRP limit of -27dBm/MHz to obtain the limit for out of band spurious emissions.

Note 2: Measure Level (dBμV/m) = Reading Level (dBμV) + Factor (dB)

Factor (dB) = Cable Loss (dB) + Antenna Factor (dB/m) - Pre_Amplifier Gain (dB)

Product	AC1200 Wi-Fi Range Extender	Test Engineer	Edgar Ma
Test Site	WZ-AC2	Test Date	2020/09/01
Test Mode	802.11ac-VHT20	Test Channel	44
Remark	1. Average measurement was not performed if peak level lower than average limit. 2. Other frequency was 20dB below limit line within 1-18GHz, there is not show in the report.		

Mark	Frequency (MHz)	Reading Level (dB μ V)	Factor (dB)	Measure Level (dB μ V/m)	Limit (dB μ V/m)	Margin (dB)	Detector	Polarization
	7443.0	33.2	8.3	41.6	74.0	-32.4	Peak	Horizontal
	8284.5	32.3	8.4	40.7	74.0	-33.3	Peak	Horizontal
*	8658.5	33.4	9.6	43.0	68.2	-25.2	Peak	Horizontal
*	10435.0	39.7	12.5	52.3	68.2	-15.9	Peak	Horizontal
	7596.0	34.1	8.2	42.4	74.0	-31.6	Peak	Vertical
	8352.5	34.0	8.6	42.7	74.0	-31.4	Peak	Vertical
*	8786.0	31.5	10.0	41.5	68.2	-26.7	Peak	Vertical
*	10435.0	44.3	12.5	56.8	68.2	-11.4	Peak	Vertical

Note 1: "*" is not in restricted band, its limit is -27dBm/MHz. At a distance of 3 meters, the field strength limit in dB μ V/m can be determined by adding a "conversion" factor of 95.2dB to the EIRP limit of -27dBm/MHz to obtain the limit for out of band spurious emissions.

Note 2: Measure Level (dB μ V/m) = Reading Level (dB μ V) + Factor (dB)

Factor (dB) = Cable Loss (dB) + Antenna Factor (dB/m) - Pre_Amplifier Gain (dB)

Product	AC1200 Wi-Fi Range Extender	Test Engineer	Edgar Ma
Test Site	WZ-AC2	Test Date	2020/09/01
Test Mode	802.11ac-VHT20	Test Channel	48
Remark	1. Average measurement was not performed if peak level lower than average limit. 2. Other frequency was 20dB below limit line within 1-18GHz, there is not show in the report.		

Mark	Frequency (MHz)	Reading Level (dB μ V)	Factor (dB)	Measure Level (dB μ V/m)	Limit (dB μ V/m)	Margin (dB)	Detector	Polarization
	7477.0	32.1	8.2	40.3	74.0	-33.7	Peak	Horizontal
	8284.5	32.5	8.4	40.9	74.0	-33.1	Peak	Horizontal
*	8735.0	32.8	9.8	42.5	68.2	-25.7	Peak	Horizontal
*	10477.5	39.5	12.6	52.1	68.2	-16.1	Peak	Horizontal
	7451.5	34.1	8.3	42.4	74.0	-31.6	Peak	Vertical
	8174.0	33.6	8.6	42.2	74.0	-31.8	Peak	Vertical
*	8692.5	33.1	9.6	42.8	68.2	-25.5	Peak	Vertical
*	10477.5	44.3	12.6	56.9	68.2	-11.3	Peak	Vertical

Note 1: "*" is not in restricted band, its limit is -27dBm/MHz. At a distance of 3 meters, the field strength limit in dB μ V/m can be determined by adding a "conversion" factor of 95.2dB to the EIRP limit of -27dBm/MHz to obtain the limit for out of band spurious emissions.

Note 2: Measure Level (dB μ V/m) = Reading Level (dB μ V) + Factor (dB)

Factor (dB) = Cable Loss (dB) + Antenna Factor (dB/m) - Pre_Amplifier Gain (dB)

Product	AC1200 Wi-Fi Range Extender	Test Engineer	Edgar Ma
Test Site	WZ-AC2	Test Date	2020/09/01
Test Mode	802.11ac-VHT20	Test Channel	52
Remark	1. Average measurement was not performed if peak level lower than average limit. 2. Other frequency was 20dB below limit line within 1-18GHz, there is not show in the report.		

Mark	Frequency (MHz)	Reading Level (dB μ V)	Factor (dB)	Measure Level (dB μ V/m)	Limit (dB μ V/m)	Margin (dB)	Detector	Polarization
	7553.5	31.9	8.2	40.1	74.0	-33.9	Peak	Horizontal
	8191.0	34.2	8.5	42.7	74.0	-31.3	Peak	Horizontal
*	8743.5	33.2	9.9	43.1	68.2	-25.1	Peak	Horizontal
*	10520.0	40.0	12.7	52.7	68.2	-15.5	Peak	Horizontal
	7553.5	34.0	8.2	42.2	74.0	-31.8	Peak	Vertical
	8097.5	34.1	9.0	43.1	74.0	-30.9	Peak	Vertical
*	8752.0	33.3	10.1	43.4	68.2	-24.8	Peak	Vertical
*	10520.0	43.4	12.7	56.1	68.2	-12.1	Peak	Vertical

Note 1: "*" is not in restricted band, its limit is -27dBm/MHz. At a distance of 3 meters, the field strength limit in dB μ V/m can be determined by adding a "conversion" factor of 95.2dB to the EIRP limit of -27dBm/MHz to obtain the limit for out of band spurious emissions.

Note 2: Measure Level (dB μ V/m) = Reading Level (dB μ V) + Factor (dB)

Factor (dB) = Cable Loss (dB) + Antenna Factor (dB/m) - Pre_Amplifier Gain (dB)

Product	AC1200 Wi-Fi Range Extender	Test Engineer	Edgar Ma
Test Site	WZ-AC2	Test Date	2020/09/01
Test Mode	802.11ac-VHT20	Test Channel	60
Remark	1. Average measurement was not performed if peak level lower than average limit. 2. Other frequency was 20dB below limit line within 1-18GHz, there is not show in the report.		

Mark	Frequency (MHz)	Reading Level (dB μ V)	Factor (dB)	Measure Level (dB μ V/m)	Limit (dB μ V/m)	Margin (dB)	Detector	Polarization
	7621.5	33.3	8.1	41.4	74.0	-32.6	Peak	Horizontal
	8199.5	34.0	8.4	42.3	74.0	-31.7	Peak	Horizontal
*	8786.0	33.2	10.0	43.2	68.2	-25.0	Peak	Horizontal
*	10596.5	40.2	12.8	53.0	68.2	-15.2	Peak	Horizontal
	8174.0	33.9	8.6	42.5	74.0	-31.5	Peak	Vertical
*	8743.5	33.9	9.9	43.8	68.2	-24.4	Peak	Vertical
*	9704.0	34.0	10.8	44.9	68.2	-23.3	Peak	Vertical
	10598.6	38.3	12.8	51.2	54.0	-2.8	Average	Vertical
	10598.6	42.0	13.0	55.0	74.0	-19.0	Peak	Vertical

Note 1: "*" is not in restricted band, its limit is -27dBm/MHz. At a distance of 3 meters, the field strength limit in dB μ V/m can be determined by adding a "conversion" factor of 95.2dB to the EIRP limit of -27dBm/MHz to obtain the limit for out of band spurious emissions.

Note 2: Measure Level (dB μ V/m) = Reading Level (dB μ V) + Factor (dB)

Factor (dB) = Cable Loss (dB) + Antenna Factor (dB/m) - Pre_Amplifier Gain (dB)

Product	AC1200 Wi-Fi Range Extender	Test Engineer	Edgar Ma
Test Site	WZ-AC2	Test Date	2020/09/01
Test Mode	802.11ac-VHT20	Test Channel	64
Remark	1. Average measurement was not performed if peak level lower than average limit. 2. Other frequency was 20dB below limit line within 1-18GHz, there is not show in the report.		

Mark	Frequency (MHz)	Reading Level (dB μ V)	Factor (dB)	Measure Level (dB μ V/m)	Limit (dB μ V/m)	Margin (dB)	Detector	Polarization
	7485.5	33.4	8.3	41.7	74.0	-32.3	Peak	Horizontal
	8165.5	34.8	8.5	43.3	74.0	-30.7	Peak	Horizontal
*	8760.5	32.3	10.1	42.4	68.2	-25.8	Peak	Horizontal
*	9755.0	33.6	10.8	44.4	68.2	-23.8	Peak	Horizontal
	7570.5	32.6	8.2	40.8	74.0	-33.2	Peak	Vertical
	8199.5	34.0	8.4	42.4	74.0	-31.6	Peak	Vertical
*	8888.0	33.1	10.0	43.2	68.2	-25.0	Peak	Vertical
*	9899.5	32.8	11.1	43.9	68.2	-24.3	Peak	Vertical

Note 1: "*" is not in restricted band, its limit is -27dBm/MHz. At a distance of 3 meters, the field strength limit in dB μ V/m can be determined by adding a "conversion" factor of 95.2dB to the EIRP limit of -27dBm/MHz to obtain the limit for out of band spurious emissions.

Note 2: Measure Level (dB μ V/m) = Reading Level (dB μ V) + Factor (dB)

Factor (dB) = Cable Loss (dB) + Antenna Factor (dB/m) - Pre_Amplifier Gain (dB)

Product	AC1200 Wi-Fi Range Extender	Test Engineer	Edgar Ma
Test Site	WZ-AC2	Test Date	2020/09/04
Test Mode	802.11ac-VHT20	Test Channel	100
Remark	1. Average measurement was not performed if peak level lower than average limit. 2. Other frequency was 20dB below limit line within 1-18GHz, there is not show in the report.		

Mark	Frequency (MHz)	Reading Level (dB μ V)	Factor (dB)	Measure Level (dB μ V/m)	Limit (dB μ V/m)	Margin (dB)	Detector	Polarization
	7698.0	34.0	8.0	42.0	74.0	-32.0	Peak	Horizontal
	8174.0	34.1	8.6	42.7	74.0	-31.3	Peak	Horizontal
*	8803.0	35.0	10.0	45.0	68.2	-23.2	Peak	Horizontal
*	10137.5	34.2	11.1	45.3	68.2	-22.9	Peak	Horizontal
	7485.5	33.3	8.3	41.6	74.0	-32.4	Peak	Vertical
	8182.5	33.6	8.6	42.2	74.0	-31.8	Peak	Vertical
*	8803.0	33.2	10.0	43.2	68.2	-25.0	Peak	Vertical
*	9925.0	33.6	10.9	44.5	68.2	-23.7	Peak	Vertical

Note 1: "*" is not in restricted band, its limit is -27dBm/MHz. At a distance of 3 meters, the field strength limit in dB μ V/m can be determined by adding a "conversion" factor of 95.2dB to the EIRP limit of -27dBm/MHz to obtain the limit for out of band spurious emissions.

Note 2: Measure Level (dB μ V/m) = Reading Level (dB μ V) + Factor (dB)

Factor (dB) = Cable Loss (dB) + Antenna Factor (dB/m) - Pre_Amplifier Gain (dB)

Product	AC1200 Wi-Fi Range Extender	Test Engineer	Edgar Ma
Test Site	WZ-AC2	Test Date	2020/09/04
Test Mode	802.11ac-VHT20	Test Channel	116
Remark	1. Average measurement was not performed if peak level lower than average limit. 2. Other frequency was 20dB below limit line within 1-18GHz, there is not show in the report.		

Mark	Frequency (MHz)	Reading Level (dB μ V)	Factor (dB)	Measure Level (dB μ V/m)	Limit (dB μ V/m)	Margin (dB)	Detector	Polarization
	7426.0	33.4	8.1	41.5	74.0	-32.5	Peak	Horizontal
	8191.0	34.2	8.5	42.8	74.0	-31.2	Peak	Horizontal
*	8956.0	37.4	9.9	47.3	68.2	-20.9	Peak	Horizontal
*	10579.5	34.8	13.1	47.9	68.2	-20.3	Peak	Horizontal
	7443.0	32.6	8.3	41.0	74.0	-33.0	Peak	Vertical
	8131.5	33.5	8.8	42.3	74.0	-31.7	Peak	Vertical
*	8769.0	32.3	10.1	42.4	68.2	-25.8	Peak	Vertical
*	9908.0	32.7	11.1	43.8	68.2	-24.4	Peak	Vertical

Note 1: "*" is not in restricted band, its limit is -27dBm/MHz. At a distance of 3 meters, the field strength limit in dB μ V/m can be determined by adding a "conversion" factor of 95.2dB to the EIRP limit of -27dBm/MHz to obtain the limit for out of band spurious emissions.

Note 2: Measure Level (dB μ V/m) = Reading Level (dB μ V) + Factor (dB)

Factor (dB) = Cable Loss (dB) + Antenna Factor (dB/m) - Pre_Amplifier Gain (dB)

Product	AC1200 Wi-Fi Range Extender	Test Engineer	Edgar Ma
Test Site	WZ-AC2	Test Date	2020/09/04
Test Mode	802.11ac-VHT20	Test Channel	140
Remark	1. Average measurement was not performed if peak level lower than average limit. 2. Other frequency was 20dB below limit line within 1-18GHz, there is not show in the report.		

Mark	Frequency (MHz)	Reading Level (dB μ V)	Factor (dB)	Measure Level (dB μ V/m)	Limit (dB μ V/m)	Margin (dB)	Detector	Polarization
	7468.5	32.2	8.2	40.4	74.0	-33.6	Peak	Horizontal
	8182.5	34.2	8.6	42.8	74.0	-31.2	Peak	Horizontal
*	8777.5	33.7	10.0	43.7	68.2	-24.5	Peak	Horizontal
*	9568.0	34.6	10.6	45.2	68.2	-23.0	Peak	Horizontal
	7349.5	34.0	8.1	42.0	74.0	-32.0	Peak	Vertical
	8301.5	34.3	8.4	42.7	74.0	-31.3	Peak	Vertical
*	8854.0	32.1	9.9	42.0	68.2	-26.2	Peak	Vertical
*	9559.5	34.5	10.7	45.2	68.2	-23.0	Peak	Vertical

Note 1: "*" is not in restricted band, its limit is -27dBm/MHz. At a distance of 3 meters, the field strength limit in dB μ V/m can be determined by adding a "conversion" factor of 95.2dB to the EIRP limit of -27dBm/MHz to obtain the limit for out of band spurious emissions.

Note 2: Measure Level (dB μ V/m) = Reading Level (dB μ V) + Factor (dB)

Factor (dB) = Cable Loss (dB) + Antenna Factor (dB/m) - Pre_Amplifier Gain (dB)

Product	AC1200 Wi-Fi Range Extender	Test Engineer	Edgar Ma
Test Site	WZ-AC2	Test Date	2020/09/04
Test Mode	802.11ac-VHT20	Test Channel	149
Remark	1. Average measurement was not performed if peak level lower than average limit. 2. Other frequency was 20dB below limit line within 1-18GHz, there is not show in the report.		

Mark	Frequency (MHz)	Reading Level (dBμV)	Factor (dB)	Measure Level (dBμV/m)	Limit (dBμV/m)	Margin (dB)	Detector	Polarization
	7400.5	34.4	8.2	42.6	74.0	-31.4	Peak	Horizontal
	11489.0	35.1	15.7	50.8	74.0	-23.2	Peak	Horizontal
*	12976.5	31.0	16.2	47.1	68.2	-21.1	Peak	Horizontal
*	15016.5	30.5	17.1	47.6	68.2	-20.6	Peak	Horizontal
	8242.0	33.0	8.5	41.5	74.0	-32.5	Peak	Vertical
	11491.8	39.6	15.7	55.3	74.0	-18.7	Peak	Vertical
	11491.8	30.4	15.7	46.0	54.0	-8.0	Average	Vertical
*	12951.0	30.6	16.5	47.1	68.2	-21.1	Peak	Vertical
*	15178.0	32.1	18.2	50.4	68.2	-17.8	Peak	Vertical

Note 1: "*" is not in restricted band, its limit is -27dBm/MHz. At a distance of 3 meters, the field strength limit in dBμV/m can be determined by adding a "conversion" factor of 95.2dB to the EIRP limit of -27dBm/MHz to obtain the limit for out of band spurious emissions.

Note 2: Measure Level (dBμV/m) = Reading Level (dBμV) + Factor (dB)

Factor (dB) = Cable Loss (dB) + Antenna Factor (dB/m) - Pre_Amplifier Gain (dB)

Product	AC1200 Wi-Fi Range Extender	Test Engineer	Edgar Ma
Test Site	WZ-AC2	Test Date	2020/09/04
Test Mode	802.11ac-VHT20	Test Channel	157
Remark	1. Average measurement was not performed if peak level lower than average limit. 2. Other frequency was 20dB below limit line within 1-18GHz, there is not show in the report.		

Mark	Frequency (MHz)	Reading Level (dBμV)	Factor (dB)	Measure Level (dBμV/m)	Limit (dBμV/m)	Margin (dB)	Detector	Polarization
	8208.0	34.1	8.3	42.4	74.0	-31.6	Peak	Horizontal
	11565.5	36.5	15.8	52.3	74.0	-21.7	Peak	Horizontal
*	13078.5	32.0	16.5	48.5	68.2	-19.7	Peak	Horizontal
*	15169.5	32.1	17.7	49.8	68.2	-18.4	Peak	Horizontal
	8114.5	33.9	9.0	42.9	74.0	-31.1	Peak	Vertical
	11565.0	30.4	15.8	46.2	54.0	-7.8	Average	Vertical
	11565.0	40.4	15.8	56.2	74.0	-17.8	Peak	Vertical
*	13172.0	31.8	17.0	48.8	68.2	-19.4	Peak	Vertical
*	15280.0	31.7	18.2	49.9	68.2	-18.3	Peak	Vertical

Note 1: "*" is not in restricted band, its limit is -27dBm/MHz. At a distance of 3 meters, the field strength limit in dBμV/m can be determined by adding a "conversion" factor of 95.2dB to the EIRP limit of -27dBm/MHz to obtain the limit for out of band spurious emissions.

Note 2: Measure Level (dBμV/m) = Reading Level (dBμV) + Factor (dB)

Factor (dB) = Cable Loss (dB) + Antenna Factor (dB/m) - Pre_Amplifier Gain (dB)

Product	AC1200 Wi-Fi Range Extender	Test Engineer	Edgar Ma
Test Site	WZ-AC2	Test Date	2020/09/04
Test Mode	802.11ac-VHT20	Test Channel	165
Remark	1. Average measurement was not performed if peak level lower than average limit. 2. Other frequency was 20dB below limit line within 1-18GHz, there is not show in the report.		

Mark	Frequency (MHz)	Reading Level (dB μ V)	Factor (dB)	Measure Level (dB μ V/m)	Limit (dB μ V/m)	Margin (dB)	Detector	Polarization
	8131.5	33.4	8.8	42.2	74.0	-31.8	Peak	Horizontal
	11642.2	37.9	16.5	54.3	74.0	-19.7	Peak	Horizontal
	11642.2	28.7	16.4	45.1	54.0	-8.9	Average	Horizontal
*	13027.5	29.8	16.4	46.3	68.2	-21.9	Peak	Horizontal
*	15152.5	32.0	17.2	49.2	68.2	-19.0	Peak	Horizontal
	8310.0	32.0	8.4	40.4	74.0	-33.6	Peak	Vertical
	11650.0	30.3	15.9	46.2	54.0	-7.8	Average	Vertical
	11650.0	43.2	15.9	59.1	74.0	-14.9	Peak	Vertical
*	13095.5	32.3	16.6	48.9	68.2	-19.3	Peak	Vertical
*	14906.0	30.7	19.0	49.7	68.2	-18.5	Peak	Vertical

Note 1: "*" is not in restricted band, its limit is -27dBm/MHz. At a distance of 3 meters, the field strength limit in dB μ V/m can be determined by adding a "conversion" factor of 95.2dB to the EIRP limit of -27dBm/MHz to obtain the limit for out of band spurious emissions.

Note 2: Measure Level (dB μ V/m) = Reading Level (dB μ V) + Factor (dB)

Factor (dB) = Cable Loss (dB) + Antenna Factor (dB/m) - Pre_Amplifier Gain (dB)

Product	AC1200 Wi-Fi Range Extender	Test Engineer	Edgar Ma
Test Site	WZ-AC2	Test Date	2020/09/04
Test Mode	802.11ac-VHT40	Test Channel	38
Remark	1. Average measurement was not performed if peak level lower than average limit. 2. Other frequency was 20dB below limit line within 1-18GHz, there is not show in the report.		

Mark	Frequency (MHz)	Reading Level (dBμV)	Factor (dB)	Measure Level (dBμV/m)	Limit (dBμV/m)	Margin (dB)	Detector	Polarization
	7553.5	33.9	8.2	42.1	74.0	-31.9	Peak	Horizontal
	8293.0	31.7	8.4	40.1	74.0	-33.9	Peak	Horizontal
*	8777.5	30.8	10.0	40.8	68.2	-27.4	Peak	Horizontal
*	10384.0	34.3	12.5	46.7	68.2	-21.5	Peak	Horizontal
	7638.5	34.9	8.1	43.0	74.0	-31.0	Peak	Vertical
	8208.0	32.4	8.3	40.7	74.0	-33.3	Peak	Vertical
*	8658.5	33.7	9.6	43.3	68.2	-24.9	Peak	Vertical
*	10375.5	34.6	12.5	47.1	68.2	-21.1	Peak	Vertical

Note 1: "*" is not in restricted band, its limit is -27dBm/MHz. At a distance of 3 meters, the field strength limit in dBμV/m can be determined by adding a "conversion" factor of 95.2dB to the EIRP limit of -27dBm/MHz to obtain the limit for out of band spurious emissions.

Note 2: Measure Level (dBμV/m) = Reading Level (dBμV) + Factor (dB)

Factor (dB) = Cable Loss (dB) + Antenna Factor (dB/m) - Pre_Amplifier Gain (dB)

Product	AC1200 Wi-Fi Range Extender	Test Engineer	Edgar Ma
Test Site	WZ-AC2	Test Date	2020/09/04
Test Mode	802.11ac-VHT40	Test Channel	46
Remark	1. Average measurement was not performed if peak level lower than average limit. 2. Other frequency was 20dB below limit line within 1-18GHz, there is not show in the report.		

Mark	Frequency (MHz)	Reading Level (dB μ V)	Factor (dB)	Measure Level (dB μ V/m)	Limit (dB μ V/m)	Margin (dB)	Detector	Polarization
	7468.5	33.1	8.2	41.3	74.0	-32.7	Peak	Horizontal
	8276.0	32.3	8.3	40.7	74.0	-33.3	Peak	Horizontal
*	8752.0	33.1	10.1	43.2	68.2	-25.0	Peak	Horizontal
*	10460.5	38.3	12.6	50.9	68.2	-17.3	Peak	Horizontal
	7434.5	32.7	8.2	40.9	74.0	-33.1	Peak	Vertical
	8216.5	34.2	8.2	42.4	74.0	-31.6	Peak	Vertical
*	8735.0	32.3	9.8	42.0	68.2	-26.2	Peak	Vertical
*	10460.5	41.5	12.6	54.1	68.2	-14.1	Peak	Vertical

Note 1: "*" is not in restricted band, its limit is -27dBm/MHz. At a distance of 3 meters, the field strength limit in dB μ V/m can be determined by adding a "conversion" factor of 95.2dB to the EIRP limit of -27dBm/MHz to obtain the limit for out of band spurious emissions.

Note 2: Measure Level (dB μ V/m) = Reading Level (dB μ V) + Factor (dB)

Factor (dB) = Cable Loss (dB) + Antenna Factor (dB/m) - Pre_Amplifier Gain (dB)

Product	AC1200 Wi-Fi Range Extender	Test Engineer	Edgar Ma
Test Site	WZ-AC2	Test Date	2020/09/04
Test Mode	802.11ac-VHT40	Test Channel	54
Remark	1. Average measurement was not performed if peak level lower than average limit. 2. Other frequency was 20dB below limit line within 1-18GHz, there is not show in the report.		

Mark	Frequency (MHz)	Reading Level (dBμV)	Factor (dB)	Measure Level (dBμV/m)	Limit (dBμV/m)	Margin (dB)	Detector	Polarization
	7468.5	32.8	8.2	41.0	74.0	-33.0	Peak	Horizontal
	8318.5	31.4	8.4	39.9	74.0	-34.1	Peak	Horizontal
*	9211.0	33.6	11.0	44.5	68.2	-23.7	Peak	Horizontal
*	10537.0	38.2	12.8	51.0	68.2	-17.2	Peak	Horizontal
	7307.0	33.7	8.1	41.8	74.0	-32.2	Peak	Vertical
	8276.0	32.7	8.3	41.0	74.0	-33.0	Peak	Vertical
*	8675.5	34.1	9.5	43.6	68.2	-24.6	Peak	Vertical
*	10545.5	41.0	12.7	53.7	68.2	-14.5	Peak	Vertical

Note 1: "*" is not in restricted band, its limit is -27dBm/MHz. At a distance of 3 meters, the field strength limit in dBμV/m can be determined by adding a "conversion" factor of 95.2dB to the EIRP limit of -27dBm/MHz to obtain the limit for out of band spurious emissions.

Note 2: Measure Level (dBμV/m) = Reading Level (dBμV) + Factor (dB)

Factor (dB) = Cable Loss (dB) + Antenna Factor (dB/m) - Pre_Amplifier Gain (dB)

Product	AC1200 Wi-Fi Range Extender	Test Engineer	Edgar Ma
Test Site	WZ-AC2	Test Date	2020/09/04
Test Mode	802.11ac-VHT40	Test Channel	62
Remark	1. Average measurement was not performed if peak level lower than average limit. 2. Other frequency was 20dB below limit line within 1-18GHz, there is not show in the report.		

Mark	Frequency (MHz)	Reading Level (dB μ V)	Factor (dB)	Measure Level (dB μ V/m)	Limit (dB μ V/m)	Margin (dB)	Detector	Polarization
	7545.0	33.6	8.2	41.8	74.0	-32.2	Peak	Horizontal
	8174.0	34.2	8.6	42.8	74.0	-31.2	Peak	Horizontal
*	8871.0	33.9	9.9	43.8	68.2	-24.4	Peak	Horizontal
*	9755.0	33.8	10.8	44.5	68.2	-23.7	Peak	Horizontal
	7596.0	32.9	8.2	41.1	74.0	-32.9	Peak	Vertical
	8174.0	34.2	8.6	42.8	74.0	-31.2	Peak	Vertical
*	8845.5	34.0	9.9	43.8	68.2	-24.4	Peak	Vertical
*	9848.5	33.4	10.9	44.2	68.2	-24.0	Peak	Vertical

Note 1: "*" is not in restricted band, its limit is -27dBm/MHz. At a distance of 3 meters, the field strength limit in dB μ V/m can be determined by adding a "conversion" factor of 95.2dB to the EIRP limit of -27dBm/MHz to obtain the limit for out of band spurious emissions.

Note 2: Measure Level (dB μ V/m) = Reading Level (dB μ V) + Factor (dB)

Factor (dB) = Cable Loss (dB) + Antenna Factor (dB/m) - Pre_Amplifier Gain (dB)

Product	AC1200 Wi-Fi Range Extender	Test Engineer	Edgar Ma
Test Site	WZ-AC2	Test Date	2020/09/04
Test Mode	802.11ac-VHT40	Test Channel	102
Remark	1. Average measurement was not performed if peak level lower than average limit. 2. Other frequency was 20dB below limit line within 1-18GHz, there is not show in the report.		

Mark	Frequency (MHz)	Reading Level (dB μ V)	Factor (dB)	Measure Level (dB μ V/m)	Limit (dB μ V/m)	Margin (dB)	Detector	Polarization
	7553.5	33.7	8.2	41.8	74.0	-32.2	Peak	Horizontal
	8191.0	34.2	8.5	42.8	74.0	-31.2	Peak	Horizontal
*	8820.0	35.9	9.8	45.6	68.2	-22.6	Peak	Horizontal
*	10392.5	33.2	12.5	45.6	68.2	-22.6	Peak	Horizontal
	7485.5	33.7	8.3	42.0	74.0	-32.0	Peak	Vertical
	8454.5	34.3	8.9	43.1	74.0	-30.9	Peak	Vertical
*	8760.5	33.2	10.1	43.3	68.2	-24.9	Peak	Vertical
*	9729.5	33.7	10.8	44.5	68.2	-23.7	Peak	Vertical

Note 1: "*" is not in restricted band, its limit is -27dBm/MHz. At a distance of 3 meters, the field strength limit in dB μ V/m can be determined by adding a "conversion" factor of 95.2dB to the EIRP limit of -27dBm/MHz to obtain the limit for out of band spurious emissions.

Note 2: Measure Level (dB μ V/m) = Reading Level (dB μ V) + Factor (dB)

Factor (dB) = Cable Loss (dB) + Antenna Factor (dB/m) - Pre_Amplifier Gain (dB)

Product	AC1200 Wi-Fi Range Extender	Test Engineer	Edgar Ma
Test Site	WZ-AC2	Test Date	2020/09/04
Test Mode	802.11ac-VHT40	Test Channel	110
Remark	1. Average measurement was not performed if peak level lower than average limit. 2. Other frequency was 20dB below limit line within 1-18GHz, there is not show in the report.		

Mark	Frequency (MHz)	Reading Level (dBμV)	Factor (dB)	Measure Level (dBμV/m)	Limit (dBμV/m)	Margin (dB)	Detector	Polarization
	7613.0	33.7	8.0	41.7	74.0	-32.3	Peak	Horizontal
	8242.0	33.6	8.5	42.1	74.0	-31.9	Peak	Horizontal
*	8947.5	35.8	9.8	45.7	68.2	-22.5	Peak	Horizontal
*	9874.0	33.7	10.9	44.5	68.2	-23.7	Peak	Horizontal
	8148.5	33.5	8.5	42.0	74.0	-32.0	Peak	Vertical
	11183.0	35.4	15.2	50.6	74.0	-23.4	Peak	Vertical
*	13087.0	29.8	16.6	46.4	68.2	-21.8	Peak	Vertical
*	15178.0	35.3	18.2	53.5	68.2	-14.7	Peak	Vertical

Note 1: "*" is not in restricted band, its limit is -27dBm/MHz. At a distance of 3 meters, the field strength limit in dBμV/m can be determined by adding a "conversion" factor of 95.2dB to the EIRP limit of -27dBm/MHz to obtain the limit for out of band spurious emissions.

Note 2: Measure Level (dBμV/m) = Reading Level (dBμV) + Factor (dB)

Factor (dB) = Cable Loss (dB) + Antenna Factor (dB/m) - Pre_Amplifier Gain (dB)

Product	AC1200 Wi-Fi Range Extender	Test Engineer	Edgar Ma
Test Site	WZ-AC2	Test Date	2020/09/04
Test Mode	802.11ac-VHT40	Test Channel	134
Remark	1. Average measurement was not performed if peak level lower than average limit. 2. Other frequency was 20dB below limit line within 1-18GHz, there is not show in the report.		

Mark	Frequency (MHz)	Reading Level (dB μ V)	Factor (dB)	Measure Level (dB μ V/m)	Limit (dB μ V/m)	Margin (dB)	Detector	Polarization
	7647.0	33.6	8.1	41.7	74.0	-32.3	Peak	Horizontal
	8182.5	35.1	8.6	43.7	74.0	-30.3	Peak	Horizontal
*	9253.5	34.2	11.0	45.3	68.2	-22.9	Peak	Horizontal
*	10443.5	33.8	12.5	46.3	68.2	-21.9	Peak	Horizontal
	7519.5	35.1	7.9	43.0	74.0	-31.0	Peak	Vertical
	8199.5	33.5	8.4	41.9	74.0	-32.1	Peak	Vertical
*	8760.5	32.2	10.1	42.3	68.2	-25.9	Peak	Vertical
*	9576.5	34.1	10.5	44.7	68.2	-23.5	Peak	Vertical

Note 1: "*" is not in restricted band, its limit is -27dBm/MHz. At a distance of 3 meters, the field strength limit in dB μ V/m can be determined by adding a "conversion" factor of 95.2dB to the EIRP limit of -27dBm/MHz to obtain the limit for out of band spurious emissions.

Note 2: Measure Level (dB μ V/m) = Reading Level (dB μ V) + Factor (dB)

Factor (dB) = Cable Loss (dB) + Antenna Factor (dB/m) - Pre_Amplifier Gain (dB)

Product	AC1200 Wi-Fi Range Extender	Test Engineer	Edgar Ma
Test Site	WZ-AC2	Test Date	2020/09/04
Test Mode	802.11ac-VHT40	Test Channel	151
Remark	1. Average measurement was not performed if peak level lower than average limit. 2. Other frequency was 20dB below limit line within 1-18GHz, there is not show in the report.		

Mark	Frequency (MHz)	Reading Level (dB μ V)	Factor (dB)	Measure Level (dB μ V/m)	Limit (dB μ V/m)	Margin (dB)	Detector	Polarization
	8199.5	33.7	8.4	42.1	74.0	-31.9	Peak	Horizontal
	11506.0	33.5	15.4	48.9	74.0	-25.1	Peak	Horizontal
*	13078.5	32.4	16.5	48.9	68.2	-19.3	Peak	Horizontal
*	15033.5	32.0	17.9	50.0	68.2	-18.2	Peak	Horizontal
	8259.0	34.0	8.2	42.2	74.0	-31.8	Peak	Vertical
	11523.0	35.0	15.4	50.4	74.0	-23.6	Peak	Vertical
*	13095.5	31.9	16.6	48.5	68.2	-19.7	Peak	Vertical
*	15016.5	31.2	17.1	48.3	68.2	-19.9	Peak	Vertical

Note 1: "*" is not in restricted band, its limit is -27dBm/MHz. At a distance of 3 meters, the field strength limit in dB μ V/m can be determined by adding a "conversion" factor of 95.2dB to the EIRP limit of -27dBm/MHz to obtain the limit for out of band spurious emissions.

Note 2: Measure Level (dB μ V/m) = Reading Level (dB μ V) + Factor (dB)

Factor (dB) = Cable Loss (dB) + Antenna Factor (dB/m) - Pre_Amplifier Gain (dB)

Product	AC1200 Wi-Fi Range Extender	Test Engineer	Edgar Ma
Test Site	WZ-AC2	Test Date	2020/09/04
Test Mode	802.11ac-VHT40	Test Channel	159
Remark	1. Average measurement was not performed if peak level lower than average limit. 2. Other frequency was 20dB below limit line within 1-18GHz, there is not show in the report.		

Mark	Frequency (MHz)	Reading Level (dB μ V)	Factor (dB)	Measure Level (dB μ V/m)	Limit (dB μ V/m)	Margin (dB)	Detector	Polarization
	8301.5	34.2	8.4	42.6	74.0	-31.4	Peak	Horizontal
	11591.0	34.9	16.4	51.4	74.0	-22.6	Peak	Horizontal
*	13027.5	31.4	16.4	47.8	68.2	-20.4	Peak	Horizontal
*	15203.5	33.3	17.3	50.6	68.2	-17.6	Peak	Horizontal
	8276.0	32.8	8.3	41.2	74.0	-32.8	Peak	Vertical
	11592.2	37.4	16.4	53.9	74.0	-20.1	Peak	Vertical
	11592.2	29.5	16.4	45.9	54.0	-8.1	Average	Vertical
*	13146.5	32.2	16.8	48.9	68.2	-19.3	Peak	Vertical
*	16487.0	32.6	17.4	50.0	68.2	-18.2	Peak	Vertical

Note 1: "*" is not in restricted band, its limit is -27dBm/MHz. At a distance of 3 meters, the field strength limit in dB μ V/m can be determined by adding a "conversion" factor of 95.2dB to the EIRP limit of -27dBm/MHz to obtain the limit for out of band spurious emissions.

Note 2: Measure Level (dB μ V/m) = Reading Level (dB μ V) + Factor (dB)

Factor (dB) = Cable Loss (dB) + Antenna Factor (dB/m) - Pre_Amplifier Gain (dB)

Product	AC1200 Wi-Fi Range Extender	Test Engineer	Edgar Ma
Test Site	WZ-AC2	Test Date	2020/09/04
Test Mode	802.11ac-VHT80	Test Channel	42
Remark	1. Average measurement was not performed if peak level lower than average limit. 2. Other frequency was 20dB below limit line within 1-18GHz, there is not show in the report.		

Mark	Frequency (MHz)	Reading Level (dB μ V)	Factor (dB)	Measure Level (dB μ V/m)	Limit (dB μ V/m)	Margin (dB)	Detector	Polarization
	7460.0	32.6	8.3	40.9	74.0	-33.1	Peak	Horizontal
	8174.0	34.7	8.6	43.3	74.0	-30.7	Peak	Horizontal
*	8820.0	32.5	9.8	42.3	68.2	-25.9	Peak	Horizontal
*	9857.0	32.9	10.9	43.8	68.2	-24.4	Peak	Horizontal
	7434.5	33.0	8.2	41.2	74.0	-32.8	Peak	Vertical
	8259.0	34.1	8.2	42.3	74.0	-31.7	Peak	Vertical
*	8888.0	33.3	10.0	43.3	68.2	-24.9	Peak	Vertical
*	10528.5	33.4	12.8	46.2	68.2	-22.0	Peak	Vertical

Note 1: "*" is not in restricted band, its limit is -27dBm/MHz. At a distance of 3 meters, the field strength limit in dB μ V/m can be determined by adding a "conversion" factor of 95.2dB to the EIRP limit of -27dBm/MHz to obtain the limit for out of band spurious emissions.

Note 2: Measure Level (dB μ V/m) = Reading Level (dB μ V) + Factor (dB)

Factor (dB) = Cable Loss (dB) + Antenna Factor (dB/m) - Pre_Amplifier Gain (dB)

Product	AC1200 Wi-Fi Range Extender	Test Engineer	Edgar Ma
Test Site	WZ-AC2	Test Date	2020/09/04
Test Mode	802.11ac-VHT80	Test Channel	58
Remark	1. Average measurement was not performed if peak level lower than average limit. 2. Other frequency was 20dB below limit line within 1-18GHz, there is not show in the report.		

Mark	Frequency (MHz)	Reading Level (dB μ V)	Factor (dB)	Measure Level (dB μ V/m)	Limit (dB μ V/m)	Margin (dB)	Detector	Polarization
	7468.5	32.4	8.2	40.5	74.0	-33.5	Peak	Horizontal
	8242.0	33.2	8.5	41.7	74.0	-32.3	Peak	Horizontal
*	8718.0	32.7	9.4	42.2	68.2	-26.0	Peak	Horizontal
*	9908.0	33.1	11.1	44.3	68.2	-23.9	Peak	Horizontal
	7443.0	34.4	8.3	42.7	74.0	-31.3	Peak	Vertical
	8191.0	34.0	8.5	42.6	74.0	-31.4	Peak	Vertical
*	8913.5	33.6	9.9	43.5	68.2	-24.7	Peak	Vertical
*	9908.0	32.9	11.1	44.1	68.2	-24.2	Peak	Vertical

Note 1: "*" is not in restricted band, its limit is -27dBm/MHz. At a distance of 3 meters, the field strength limit in dB μ V/m can be determined by adding a "conversion" factor of 95.2dB to the EIRP limit of -27dBm/MHz to obtain the limit for out of band spurious emissions.

Note 2: Measure Level (dB μ V/m) = Reading Level (dB μ V) + Factor (dB)

Factor (dB) = Cable Loss (dB) + Antenna Factor (dB/m) - Pre_Amplifier Gain (dB)

Product	AC1200 Wi-Fi Range Extender	Test Engineer	Edgar Ma
Test Site	WZ-AC2	Test Date	2020/09/04
Test Mode	802.11ac-VHT80	Test Channel	106
Remark	1. Average measurement was not performed if peak level lower than average limit. 2. Other frequency was 20dB below limit line within 1-18GHz, there is not show in the report.		

Mark	Frequency (MHz)	Reading Level (dBμV)	Factor (dB)	Measure Level (dBμV/m)	Limit (dBμV/m)	Margin (dB)	Detector	Polarization
	7536.5	34.1	8.1	42.1	74.0	-31.9	Peak	Horizontal
	8165.5	33.1	8.5	41.6	74.0	-32.4	Peak	Horizontal
*	8845.5	35.3	9.9	45.1	68.2	-23.1	Peak	Horizontal
*	9874.0	34.3	10.9	45.2	68.2	-23.0	Peak	Horizontal
	7400.5	31.9	8.2	40.0	74.0	-34.0	Peak	Vertical
	8191.0	34.3	8.5	42.9	74.0	-31.1	Peak	Vertical
*	8828.5	33.4	9.8	43.2	68.2	-25.0	Peak	Vertical
*	9772.0	34.3	10.6	44.8	68.2	-23.4	Peak	Vertical

Note 1: "*" is not in restricted band, its limit is -27dBm/MHz. At a distance of 3 meters, the field strength limit in dBμV/m can be determined by adding a "conversion" factor of 95.2dB to the EIRP limit of -27dBm/MHz to obtain the limit for out of band spurious emissions.

Note 2: Measure Level (dBμV/m) = Reading Level (dBμV) + Factor (dB)

Factor (dB) = Cable Loss (dB) + Antenna Factor (dB/m) - Pre_Amplifier Gain (dB)

Product	AC1200 Wi-Fi Range Extender	Test Engineer	Edgar Ma
Test Site	WZ-AC2	Test Date	2020/09/04
Test Mode	802.11ac-VHT80	Test Channel	122
Remark	1. Average measurement was not performed if peak level lower than average limit. 2. Other frequency was 20dB below limit line within 1-18GHz, there is not show in the report.		

Mark	Frequency (MHz)	Reading Level (dB μ V)	Factor (dB)	Measure Level (dB μ V/m)	Limit (dB μ V/m)	Margin (dB)	Detector	Polarization
	7434.5	32.8	8.2	41.0	74.0	-33.0	Peak	Horizontal
	8182.5	33.8	8.6	42.4	74.0	-31.6	Peak	Horizontal
*	8973.0	36.5	9.9	46.4	68.2	-21.8	Peak	Horizontal
*	10401.0	32.8	12.6	45.5	68.2	-22.7	Peak	Horizontal
	7434.5	34.0	8.2	42.3	74.0	-31.8	Peak	Vertical
	8242.0	33.2	8.5	41.7	74.0	-32.3	Peak	Vertical
*	8973.0	34.3	9.9	44.2	68.2	-24.0	Peak	Vertical
*	9984.5	33.3	11.2	44.5	68.2	-23.7	Peak	Vertical

Note 1: "*" is not in restricted band, its limit is -27dBm/MHz. At a distance of 3 meters, the field strength limit in dB μ V/m can be determined by adding a "conversion" factor of 95.2dB to the EIRP limit of -27dBm/MHz to obtain the limit for out of band spurious emissions.

Note 2: Measure Level (dB μ V/m) = Reading Level (dB μ V) + Factor (dB)

Factor (dB) = Cable Loss (dB) + Antenna Factor (dB/m) - Pre_Amplifier Gain (dB)

Product	AC1200 Wi-Fi Range Extender	Test Engineer	Edgar Ma
Test Site	WZ-AC2	Test Date	2020/09/04
Test Mode	802.11ac-VHT80	Test Channel	155
Remark	1. Average measurement was not performed if peak level lower than average limit. 2. Other frequency was 20dB below limit line within 1-18GHz, there is not show in the report.		

Mark	Frequency (MHz)	Reading Level (dB μ V)	Factor (dB)	Measure Level (dB μ V/m)	Limit (dB μ V/m)	Margin (dB)	Detector	Polarization
	7468.5	32.8	8.2	41.0	74.0	-33.0	Peak	Horizontal
	8191.0	34.8	8.5	43.3	74.0	-30.7	Peak	Horizontal
*	9236.5	34.6	10.9	45.5	68.2	-22.7	Peak	Horizontal
*	10469.0	32.8	12.7	45.5	68.2	-22.7	Peak	Horizontal
	7485.5	32.7	8.3	41.0	74.0	-33.0	Peak	Vertical
	8148.5	34.2	8.5	42.7	74.0	-31.3	Peak	Vertical
*	9236.5	34.7	10.9	45.5	68.2	-22.7	Peak	Vertical
*	9984.5	32.9	11.2	44.1	68.2	-24.1	Peak	Vertical

Note 1: "*" is not in restricted band, its limit is -27dBm/MHz. At a distance of 3 meters, the field strength limit in dB μ V/m can be determined by adding a "conversion" factor of 95.2dB to the EIRP limit of -27dBm/MHz to obtain the limit for out of band spurious emissions.

Note 2: Measure Level (dB μ V/m) = Reading Level (dB μ V) + Factor (dB)

Factor (dB) = Cable Loss (dB) + Antenna Factor (dB/m) - Pre_Amplifier Gain (dB)

The Result of Radiated Emission below 1GHz:

Site: WZ-AC2	Time: 2020/11/05 - 19:40
Limit: FCC_Part15.209_RE(3m)	Engineer: Hyde Yu
Probe: WZ-AC2_VULB9162_0.03-7GHz	Polarity: Horizontal
EUT: AC1200 Wi-Fi Range Extender	Power: AC 120V/60Hz
Test Mode: Transmit by 802.11a at Channel 5180MHz	

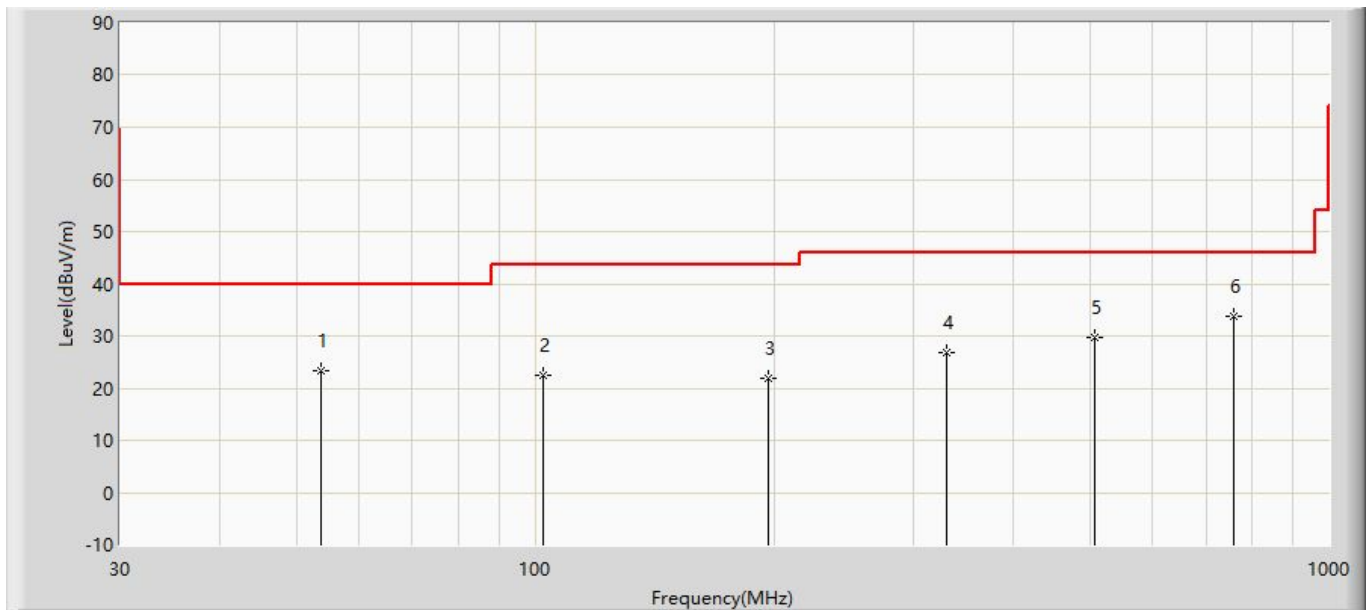

No	Flag	Mark	Frequency (MHz)	Measure Level (dBuV/m)	Reading Level (dBuV)	Margin (dB)	Limit (dBuV/m)	Factor	Type
1			53.765	23.469	3.098	-16.531	40.000	20.371	PK
2			102.265	22.481	3.880	-21.019	43.500	18.601	PK
3			196.355	21.958	2.929	-21.542	43.500	19.028	PK
4			329.730	26.926	4.904	-19.074	46.000	22.022	PK
5			507.725	29.787	4.442	-16.213	46.000	25.345	PK
6		*	757.985	33.635	3.892	-12.365	46.000	29.743	PK

Note 1: Measure Level (dB μ V/m) = Reading Level (dB μ V) + Factor (dB)

Factor (dB) = Cable Loss (dB) + Antenna Factor (dB/m)

Note 2: The amplitude of radiated emissions (frequency range from 9kHz to 30MHz and 18GHz to 40GHz) is that proximity to ambient noise, which also are attenuated more than 20 dB below the permissible value.

Therefore, the data is not presented in the report.

Site: WZ-AC2	Time: 2020/11/05 - 19:40
Limit: FCC_Part15.209_RE(3m)	Engineer: Hyde Yu
Probe: WZ- AC2_VULB9162_0.03-7GHz	Polarity: Vertical
EUT: AC1200 Wi-Fi Range Extender	Power: AC 120V/60Hz
Test Mode: Transmit by 802.11a at Channel 5180MHz	

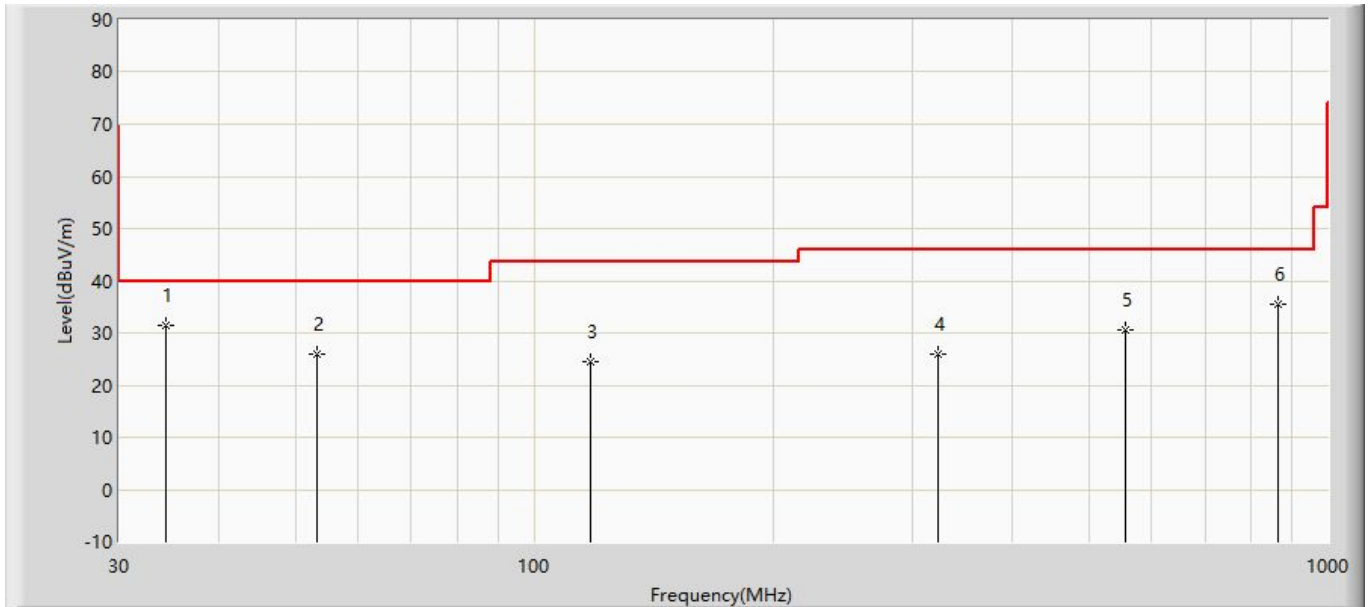

No	Flag	Mark	Frequency (MHz)	Measure Level (dBuV/m)	Reading Level (dBuV)	Margin (dB)	Limit (dBuV/m)	Factor	Type
1		*	34.365	31.329	13.402	-8.671	40.000	17.927	PK
2			53.280	25.954	5.521	-14.046	40.000	20.433	PK
3			117.785	24.410	7.313	-19.090	43.500	17.097	PK
4			323.425	26.065	4.318	-19.935	46.000	21.747	PK
5			556.225	30.563	4.316	-15.437	46.000	26.247	PK
6			866.625	35.476	4.202	-10.524	46.000	31.273	PK

Note 1: Measure Level (dBuV/m) = Reading Level (dBuV) + Factor (dB)

Factor (dB) = Cable Loss (dB) + Antenna Factor (dB/m)

Note 2: The amplitude of radiated emissions (frequency range from 9kHz to 30MHz and 18GHz to 40GHz) is that proximity to ambient noise, which also are attenuated more than 20 dB below the permissible value.

Therefore, the data is not presented in the report.

6.9. Radiated Restricted Band Edge Measurement

6.9.1. Test Limit

For 15.205 Requirement:

Radiated emissions which fall in the restricted bands, as defined in Section 15.205(a) of FCC part 15, must also comply with the radiated emission limits specified in Section 15.209(a).

Frequency (MHz)	Frequency (MHz)	Frequency (MHz)	Frequency (GHz)
0.090 - 0.110	16.42-16.423	399.9 - 410	4.5-5.15
¹ 0.495 - 0.505	16.69475-16.69525	608 - 614	5.35-5.46
2.1735-2.1905	16.80425-16.80475	960 - 1240	7.25-7.75
4.125-4.128	25.5 -25.67	1300 - 1427	8.025 - 8.5
4.17725-4.17775	37.5-38.25	1435-1626.5	9.0-9.2
4.20725-4.20775	73-74.6	1645.5-1646.5	9.3-9.5
6.215-6.218	74.8-75.2	1660 - 1710	10.6-12.7
6.26775-6.26825	108-121.94	1718.8-1722.2	13.25-13.4
6.31175-6.31225	123 - 138	2200 - 2300	14.47-14.5
8.291-8.294	149.9-150.05	2310–2390	15.35-16.2
8.362-8.366	156.52475-156.52525	2483.5 - 2500	17.7-21.4
8.37625-8.38675	156.7-156.9	2690 - 2900	22.01-23.12
8.41425-8.41475	162.0125-167.17	3260 - 3267	23.6-24.0
12.29-12.293	167.72-173.2	3332 - 3339	31.2-31.8
12.51975-12.52025	240 - 285	3345.8 - 3358	36.43-36.5
12.57675-12.57725	322-335.4	3600 - 4400	(²)
13.36-13.41	--	--	--

For 15.407(b) Requirement:

For transmitters operating in the 5.15-5.25 GHz band: All emissions outside of the 5.15-5.35 GHz band shall not exceed an e.i.r.p. of -27 dBm/MHz.

For transmitters operating in the 5.25-5.35 GHz band: All emissions outside of the 5.15-5.35 GHz band shall not exceed an e.i.r.p. of -27 dBm/MHz.

For transmitters operating in the 5.47-5.725 GHz band: All emissions outside of the 5.47-5.725 GHz band shall not exceed an e.i.r.p. of -27 dBm/MHz.

For transmitters operating in the 5.725-5.85 GHz band: All emissions within the frequency range

from the band edge to 10 MHz above or below the band edge shall not exceed an e.i.r.p. of -17 dBm/MHz; for frequencies 10 MHz or greater above or below the band edge, emissions shall not exceed an e.i.r.p. of -27 dBm/MHz.

Refer to KDB 789033 D02v02r01 G)2)c), as specified in § 15.407(b), emissions above 1000 MHz that are outside of the restricted bands are subject to a maximum emission limit of -27 dBm/MHz (or -17 dBm/MHz as specified in § 15.407(b)(4)). However, an out-of-band emission that complies with both the peak and average limits of § 15.209 is not required to satisfy the -27 dBm/MHz or -17 dBm/MHz maximum emission limit.

All out of band emissions appearing in a restricted band as specified in Section 15.205 of the Title 47CFR must not exceed the limits shown in Table per Section 15.209.

FCC Part 15 Subpart C Paragraph 15.209		
Frequency (MHz)	Field Strength (µV/m)	Measured Distance (m)
0.009 - 0.490	2400/F (kHz)	300
0.490 - 1.705	24000/F (kHz)	30
1.705 - 30	30	30
30 - 88	100	3
88 - 216	150	3
216 - 960	200	3
Above 960	500	3

6.9.2. Test Procedure Used

KDB 789033 D02v02r01- Section G

6.9.3. Test Setting

Peak Measurements above 1GHz

1. Analyzer center frequency was set to the frequency of the radiated spurious emission of interest
2. RBW = 1MHz
3. VBW = 3MHz
4. Detector = Peak
5. Sweep time = Auto couple
6. Trace mode = Max hold
7. Trace was allowed to stabilize

Average Measurements above 1GHz (Method VB)

1. Analyzer center frequency was set to the frequency of the radiated spurious emission of interest
2. RBW = 1MHz
3. VBW; if the EUT is configured to transmit with duty cycle $\geq 98\%$, set VBW = 10Hz
4. If the EUT duty cycle is $< 98\%$, set VBW $\geq 1/T$. T is the minimum transmission duration
5. Detector = Peak
6. Sweep time = Auto
7. Trace mode = Max hold
8. Trace was allowed to stabilize

6.9.4. Test Setup

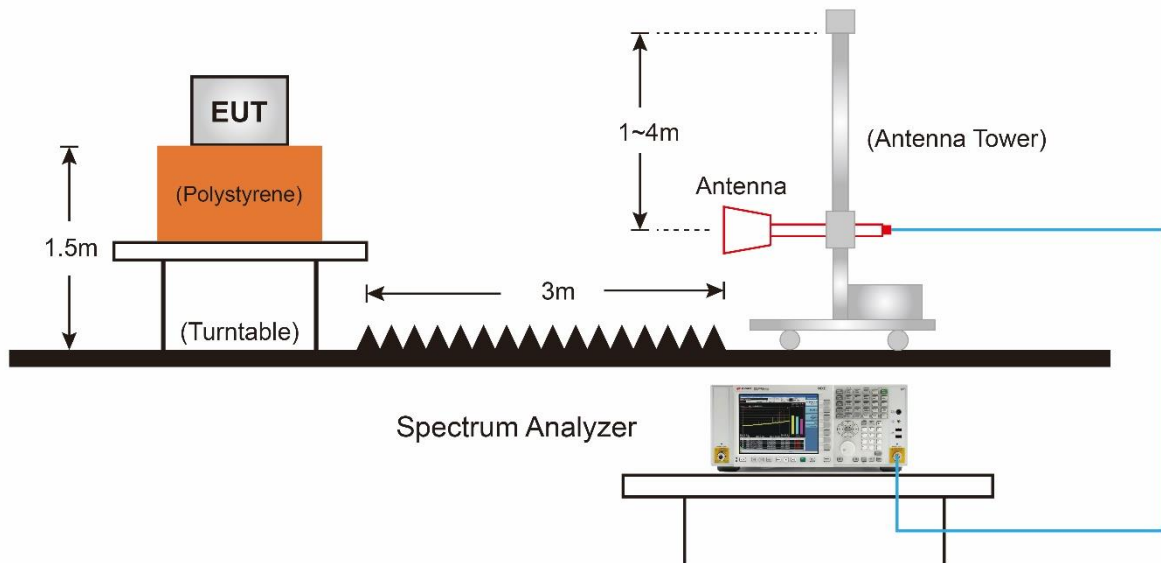

6.9.5. Test Result

Site: WZ-AC2	Time: 2020/08/30 - 11:21
Limit: FCC_Part15.209_RE(3m)	Engineer: Hyde Yu
Probe: WZ-AC2_BBHA9120D_1-18GHz	Polarity: Horizontal
EUT: AC1200 Wi-Fi Range Extender	Power: AC 120V/60Hz
Test Mode: Transmit by 802.11a at Channel 5180MHz	

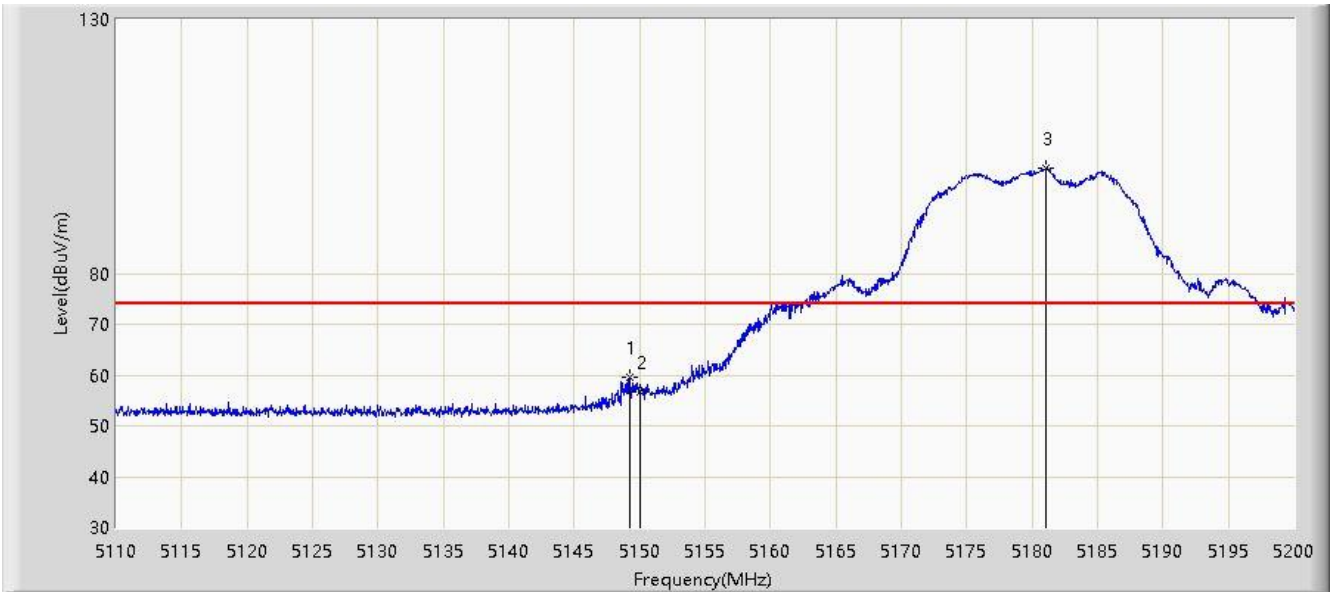

No	Flag	Mark	Frequency (MHz)	Measure Level (dBuV/m)	Reading Level (dBuV)	Margin (dB)	Limit (dBuV/m)	Factor (dB)	Type
1			5149.195	59.517	59.122	-14.483	74.000	0.395	PK
2			5150.000	56.522	56.120	-17.478	74.000	0.402	PK
3		*	5181.055	100.743	100.403	N/A	N/A	0.341	PK

Note: Measure Level (dB μ V/m) = Reading Level (dB μ V) + Factor (dB)

Factor (dB) = Cable Loss (dB) + Antenna Factor (dB/m) - Pre_Amplifier Gain (dB)

Site: WZ-AC2	Time: 2020/08/30 - 11:20
Limit: FCC_Part15.209_RE(3m)	Engineer: Hyde Yu
Probe: WZ-AC2_BBHA9120D_1-18GHz	Polarity: Horizontal
EUT: AC1200 Wi-Fi Range Extender	Power: AC 120V/60Hz
Test Mode: Transmit by 802.11a at Channel 5180MHz	

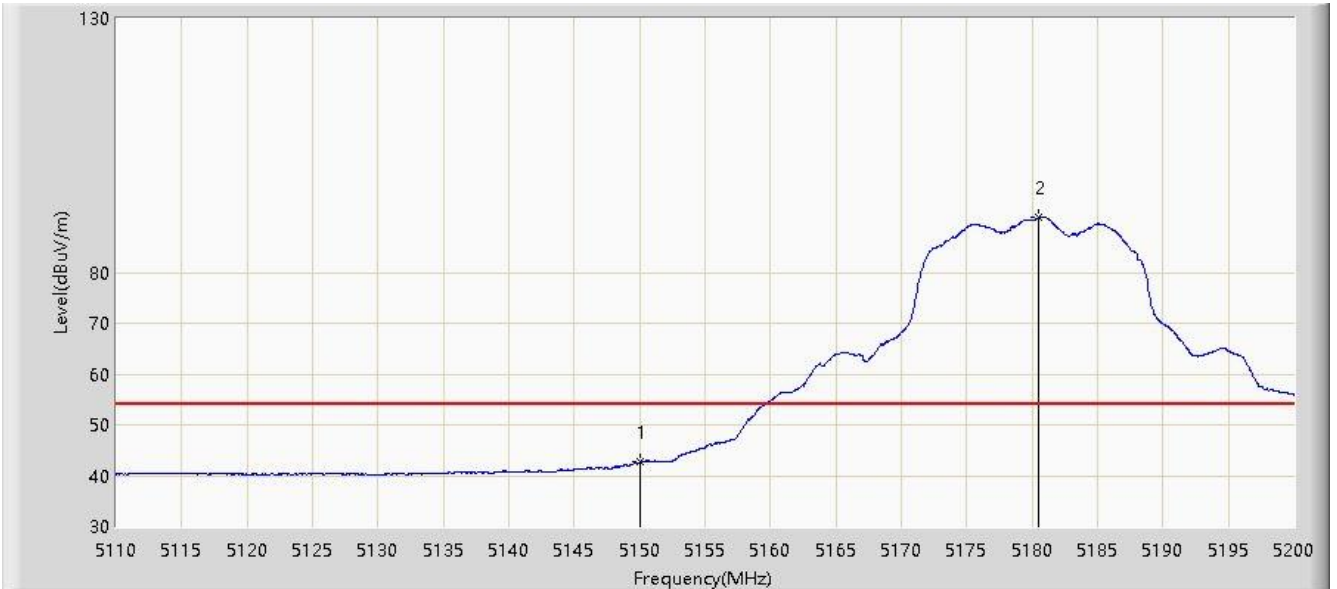

No	Flag	Mark	Frequency (MHz)	Measure Level (dBuV/m)	Reading Level (dBuV)	Margin (dB)	Limit (dBuV/m)	Factor (dB)	Type
1			5150.000	42.695	42.293	-11.305	54.000	0.402	AV
2		*	5180.515	90.774	90.428	N/A	N/A	0.347	AV

Note: Measure Level (dB μ V/m) = Reading Level (dB μ V) + Factor (dB)

Factor (dB) = Cable Loss (dB) + Antenna Factor (dB/m) - Pre_Amplifier Gain (dB)

Site: WZ-AC2	Time: 2020/08/30 - 11:22
Limit: FCC_Part15.209_RE(3m)	Engineer: Hyde Yu
Probe: WZ-AC2_BBHA9120D_1-18GHz	Polarity: Vertical
EUT: AC1200 Wi-Fi Range Extender	Power: AC 120V/60Hz
Test Mode: Transmit by 802.11a at Channel 5180MHz	



No	Flag	Mark	Frequency (MHz)	Measure Level (dBuV/m)	Reading Level (dBuV)	Margin (dB)	Limit (dBuV/m)	Factor (dB)	Type
1			5149.465	73.033	72.636	-0.967	74.000	0.397	PK
2			5150.000	71.751	71.349	-2.249	74.000	0.402	PK
3		*	5180.920	114.786	114.444	N/A	N/A	0.342	PK

Note: Measure Level (dB μ V/m) = Reading Level (dB μ V) + Factor (dB)

Factor (dB) = Cable Loss (dB) + Antenna Factor (dB/m) - Pre_Amplifier Gain (dB)

Site: WZ-AC2	Time: 2020/08/30 - 11:17
Limit: FCC_Part15.209_RE(3m)	Engineer: Hyde Yu
Probe: WZ-AC2_BBHA9120D_1-18GHz	Polarity: Vertical
EUT: AC1200 Wi-Fi Range Extender	Power: AC 120V/60Hz
Test Mode: Transmit by 802.11a at Channel 5180MHz	

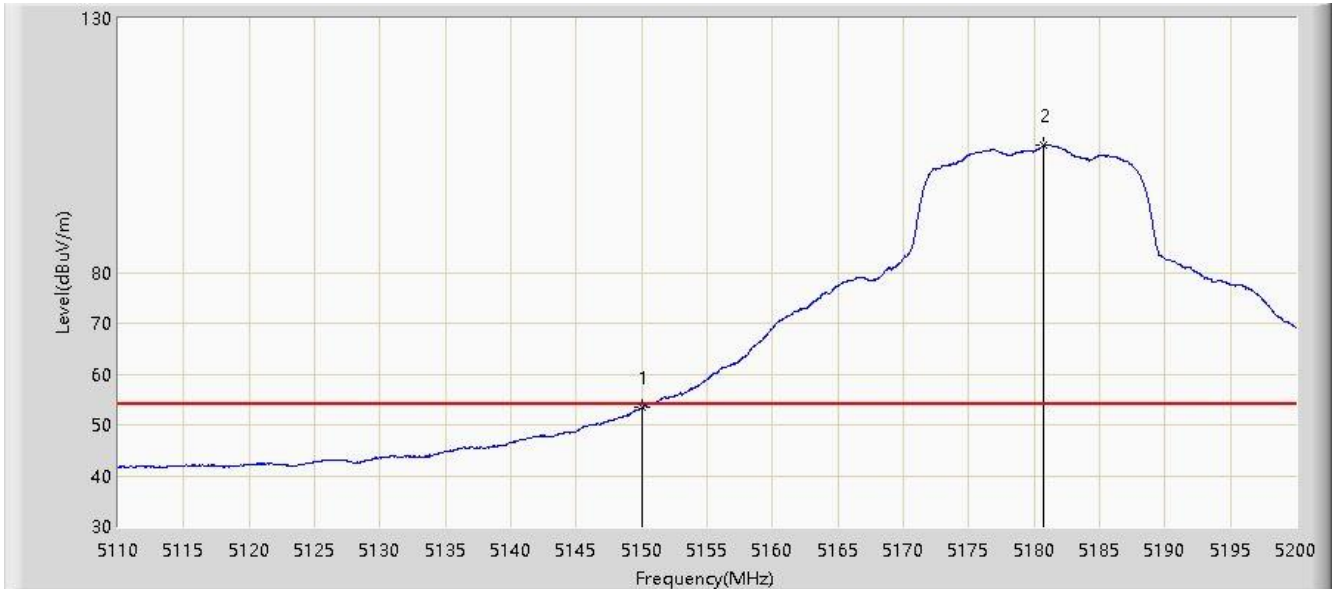

No	Flag	Mark	Frequency (MHz)	Measure Level (dBuV/m)	Reading Level (dBuV)	Margin (dB)	Limit (dBuV/m)	Factor (dB)	Type
1			5150.000	53.373	52.971	-0.627	54.000	0.402	AV
2		*	5180.740	105.086	104.742	N/A	N/A	0.344	AV

Note: Measure Level (dB μ V/m) = Reading Level (dB μ V) + Factor (dB)

Factor (dB) = Cable Loss (dB) + Antenna Factor (dB/m) - Pre_Amplifier Gain (dB)

Site: WZ-AC2	Time: 2020/08/22 - 12:00
Limit: FCC_Part15.209_RE(3m)	Engineer: Hyde Yu
Probe: WZ-AC2_BBHA9120D_1-18GHz	Polarity: Horizontal
EUT: AC1200 Wi-Fi Range Extender	Power: AC 120V/60Hz
Test Mode: Transmit by 802.11a at Channel 5240MHz	

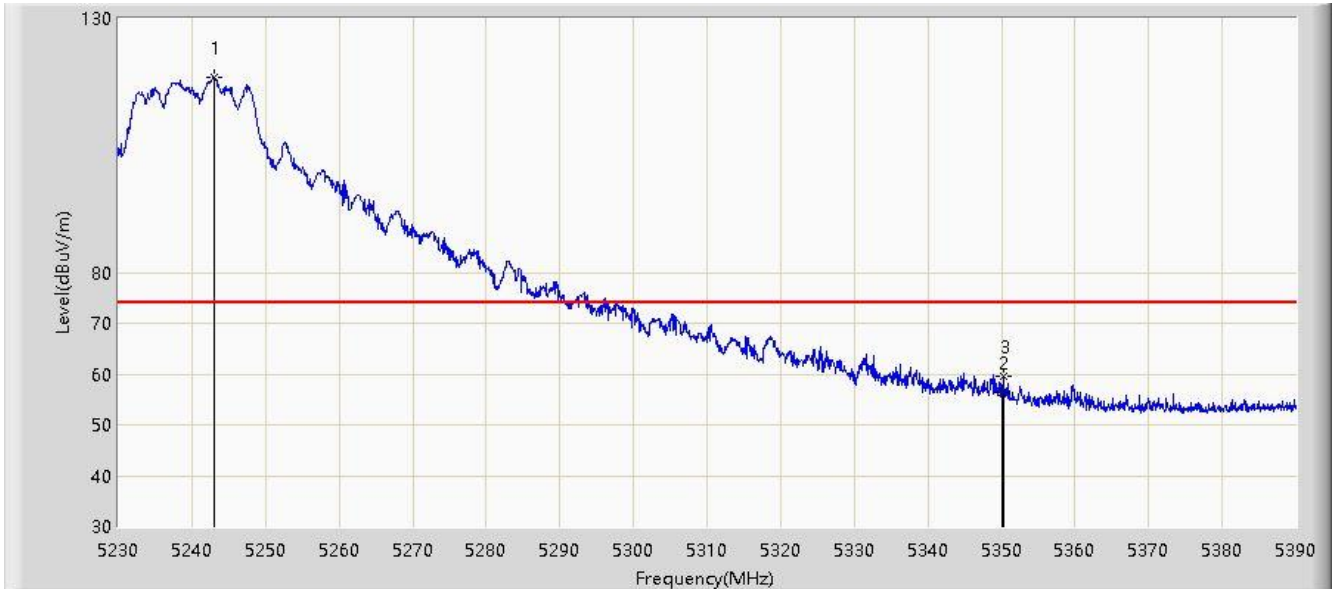

No	Flag	Mark	Frequency (MHz)	Measure Level (dBuV/m)	Reading Level (dBuV)	Margin (dB)	Limit (dBuV/m)	Factor (dB)	Type
1		*	5242.960	118.377	118.354	N/A	N/A	0.022	PK
2			5350.000	56.364	56.283	-17.636	74.000	0.081	PK
3			5350.320	59.508	59.425	-14.492	74.000	0.083	PK

Note: Measure Level (dB μ V/m) = Reading Level (dB μ V) + Factor (dB)

Factor (dB) = Cable Loss (dB) + Antenna Factor (dB/m) - Pre_Amplifier Gain (dB)

Site: WZ-AC2	Time: 2020/08/22 - 11:38
Limit: FCC_Part15.209_RE(3m)	Engineer: Hyde Yu
Probe: WZ-AC2_BBHA9120D_1-18GHz	Polarity: Horizontal
EUT: AC1200 Wi-Fi Range Extender	Power: AC 120V/60Hz
Test Mode: Transmit by 802.11a at Channel 5240MHz	

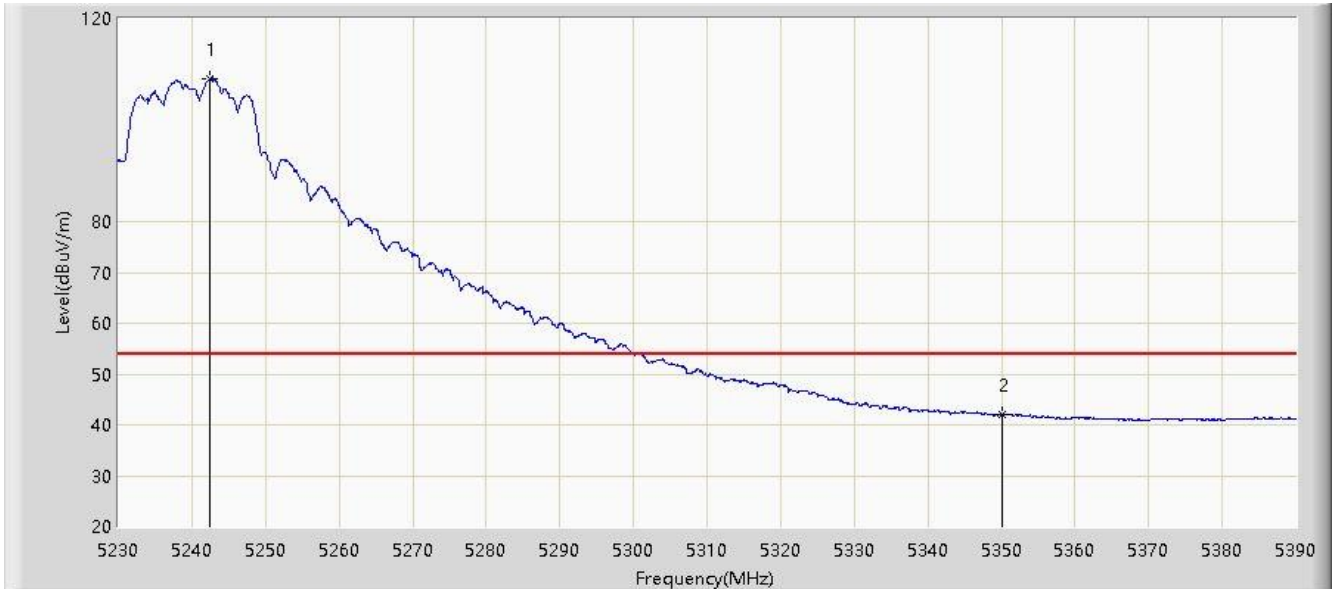

No	Flag	Mark	Frequency (MHz)	Measure Level (dBuV/m)	Reading Level (dBuV)	Margin (dB)	Limit (dBuV/m)	Factor (dB)	Type
1	X	*	5242.400	108.083	108.073	N/A	N/A	0.010	AV
2			5350.000	42.122	42.041	-11.878	54.000	0.081	AV

Note: Measure Level (dB μ V/m) = Reading Level (dB μ V) + Factor (dB)

Factor (dB) = Cable Loss (dB) + Antenna Factor (dB/m) - Pre_Amplifier Gain (dB)

Site: WZ-AC2	Time: 2020/08/22 - 11:58
Limit: FCC_Part15.209_RE(3m)	Engineer: Hyde Yu
Probe: WZ-AC2_BBHA9120D_1-18GHz	Polarity: Vertical
EUT: AC1200 Wi-Fi Range Extender	Power: AC 120V/60Hz
Test Mode: Transmit by 802.11a at Channel 5240MHz	

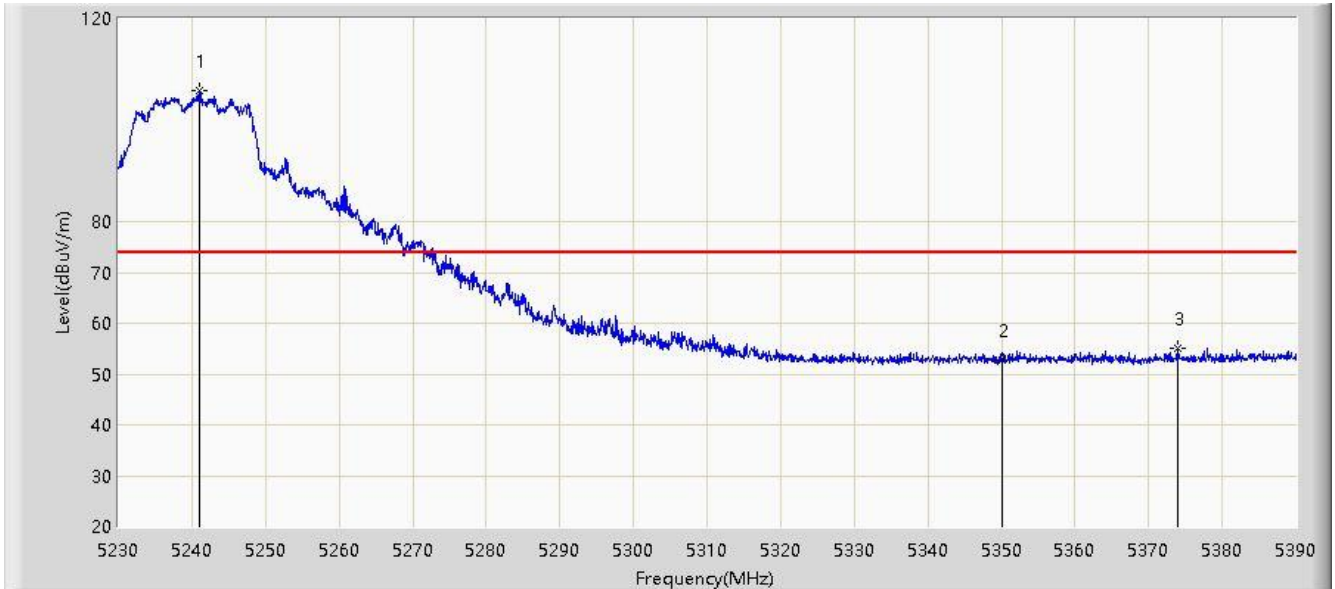

No	Flag	Mark	Frequency (MHz)	Measure Level (dBuV/m)	Reading Level (dBuV)	Margin (dB)	Limit (dBuV/m)	Factor (dB)	Type
1		*	5240.960	105.807	105.831	N/A	N/A	-0.023	PK
2			5350.000	52.762	52.681	-21.238	74.000	0.081	PK
3			5373.920	55.210	55.082	-18.790	74.000	0.129	PK

Note: Measure Level (dBuV/m) = Reading Level (dBuV) + Factor (dB)

Factor (dB) = Cable Loss (dB) + Antenna Factor (dB/m) - Pre_Amplifier Gain (dB)

Site: WZ-AC2	Time: 2020/08/22 - 11:57
Limit: FCC_Part15.209_RE(3m)	Engineer: Hyde Yu
Probe: WZ-AC2_BBHA9120D_1-18GHz	Polarity: Vertical
EUT: AC1200 Wi-Fi Range Extender	Power: AC 120V/60Hz
Test Mode: Transmit by 802.11a at Channel 5240MHz	

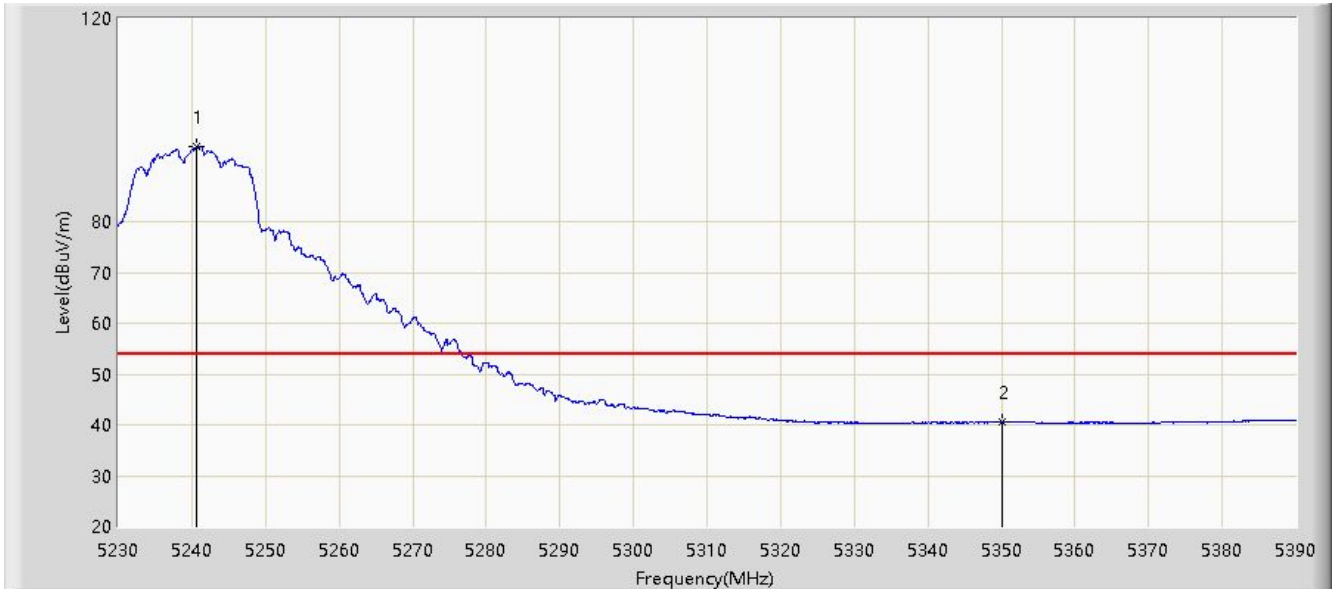

No	Flag	Mark	Frequency (MHz)	Measure Level (dBuV/m)	Reading Level (dBuV)	Margin (dB)	Limit (dBuV/m)	Factor (dB)	Type
1		*	5240.560	94.713	94.746	N/A	N/A	-0.033	AV
2			5350.000	40.528	40.447	-13.472	54.000	0.081	AV

Note: Measure Level (dB μ V/m) = Reading Level (dB μ V) + Factor (dB)

Factor (dB) = Cable Loss (dB) + Antenna Factor (dB/m) - Pre_Amplifier Gain (dB)

Site: WZ-AC2	Time: 2020/08/27 - 11:51
Limit: FCC_Part15.209_RE(3m)	Engineer: Hyde Yu
Probe: WZ-AC2_BBHA9120D_1-18GHz	Polarity: Horizontal
EUT: AC1200 Wi-Fi Range Extender	Power: AC 120V/60Hz
Test Mode: Transmit by 802.11a at Channel 5320MHz	

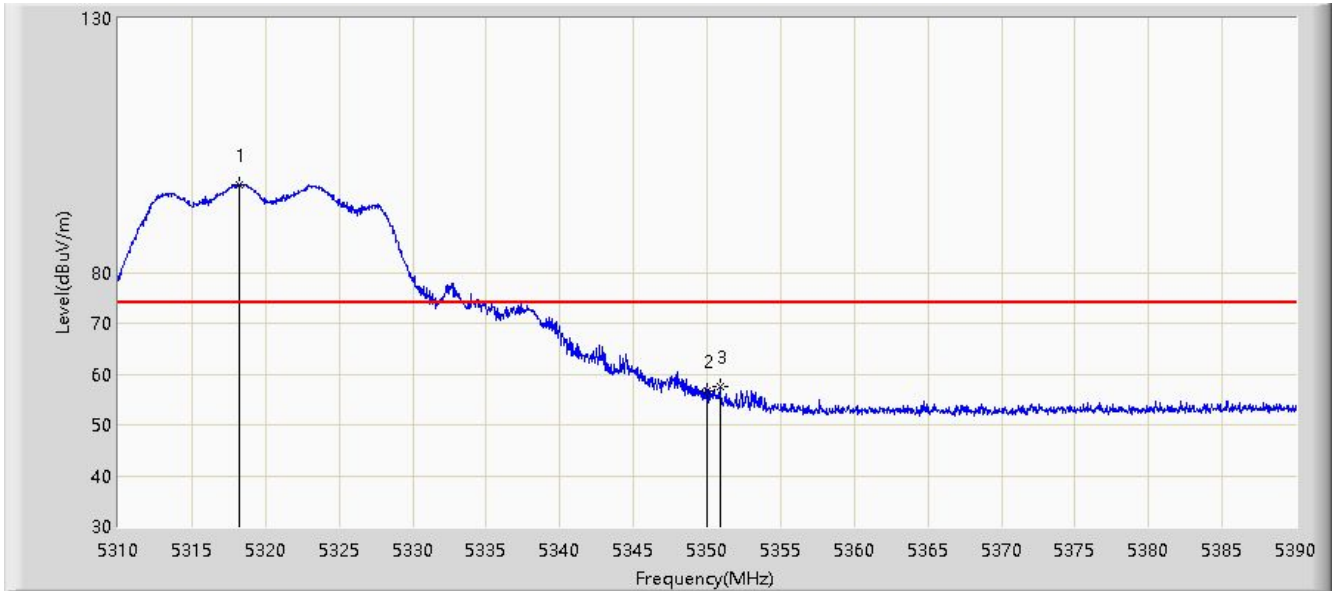

No	Flag	Mark	Frequency (MHz)	Measure Level (dBuV/m)	Reading Level (dBuV)	Margin (dB)	Limit (dBuV/m)	Factor (dB)	Type
1		*	5318.240	97.251	97.319	N/A	N/A	-0.068	PK
2			5350.000	56.597	56.516	-17.403	74.000	0.081	PK
3			5350.880	57.546	57.459	-16.454	74.000	0.087	PK

Note: Measure Level (dBuV/m) = Reading Level (dBuV) + Factor (dB)

Factor (dB) = Cable Loss (dB) + Antenna Factor (dB/m) - Pre_Amplifier Gain (dB)

Site: WZ-AC2	Time: 2020/08/27 - 11:50
Limit: FCC_Part15.209_RE(3m)	Engineer: Hyde Yu
Probe: WZ-AC2_BBHA9120D_1-18GHz	Polarity: Horizontal
EUT: AC1200 Wi-Fi Range Extender	Power: AC 120V/60Hz
Test Mode: Transmit by 802.11a at Channel 5320MHz	



No	Flag	Mark	Frequency (MHz)	Measure Level (dBuV/m)	Reading Level (dBuV)	Margin (dB)	Limit (dBuV/m)	Factor (dB)	Type
1		*	5318.360	87.301	87.371	N/A	N/A	-0.069	AV
2			5350.000	42.622	42.541	-11.378	54.000	0.081	AV

Note: Measure Level (dB μ V/m) = Reading Level (dB μ V) + Factor (dB)

Factor (dB) = Cable Loss (dB) + Antenna Factor (dB/m) - Pre_Amplifier Gain (dB)

Site: WZ-AC2	Time: 2020/08/27 - 11:52
Limit: FCC_Part15.209_RE(3m)	Engineer: Hyde Yu
Probe: WZ-AC2_BBHA9120D_1-18GHz	Polarity: Vertical
EUT: AC1200 Wi-Fi Range Extender	Power: AC 120V/60Hz
Test Mode: Transmit by 802.11a at Channel 5320MHz	



No	Flag	Mark	Frequency (MHz)	Measure Level (dBuV/m)	Reading Level (dBuV)	Margin (dB)	Limit (dBuV/m)	Factor (dB)	Type
1		*	5320.920	114.998	115.113	N/A	N/A	-0.115	PK
2			5350.000	70.932	70.851	-3.068	74.000	0.081	PK
3			5353.160	71.491	71.400	-2.509	74.000	0.092	PK

Note: Measure Level (dB μ V/m) = Reading Level (dB μ V) + Factor (dB)

Factor (dB) = Cable Loss (dB) + Antenna Factor (dB/m) - Pre_Amplifier Gain (dB)

Site: WZ-AC2	Time: 2020/08/27 - 11:41
Limit: FCC_Part15.209_RE(3m)	Engineer: Hyde Yu
Probe: WZ-AC2_BBHA9120D_1-18GHz	Polarity: Vertical
EUT: AC1200 Wi-Fi Range Extender	Power: AC 120V/60Hz
Test Mode: Transmit by 802.11a at Channel 5320MHz	

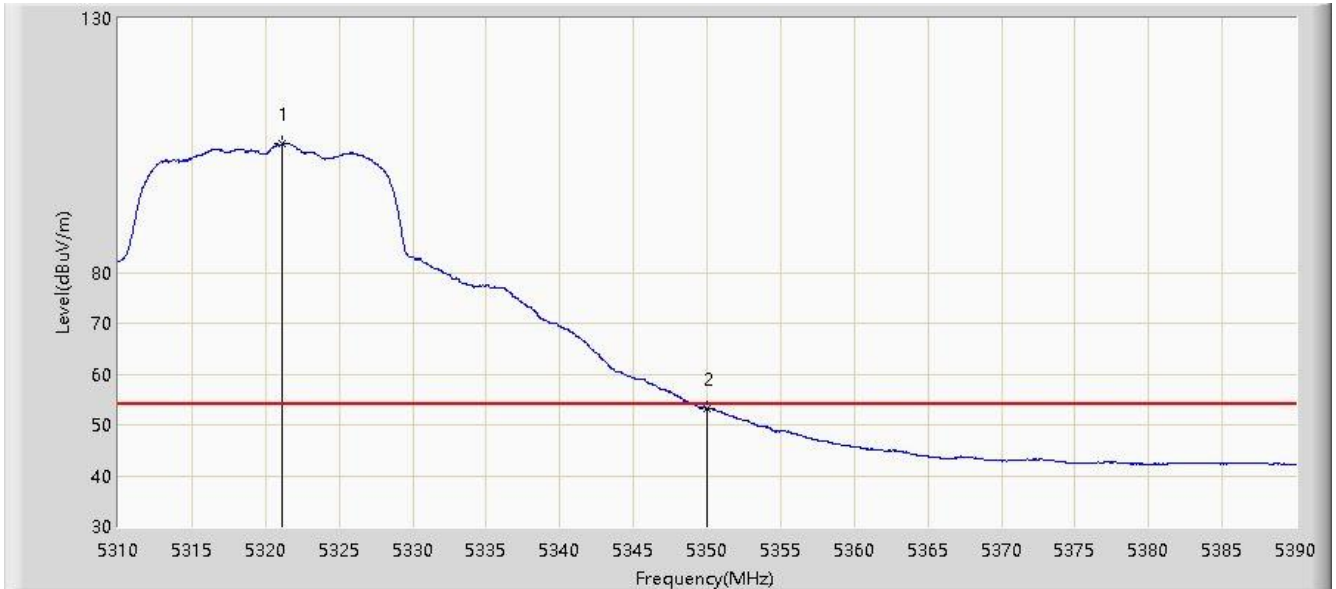

No	Flag	Mark	Frequency (MHz)	Measure Level (dBuV/m)	Reading Level (dBuV)	Margin (dB)	Limit (dBuV/m)	Factor (dB)	Type
1		*	5321.160	105.343	105.462	N/A	N/A	-0.119	AV
2			5350.000	53.174	53.093	-0.826	54.000	0.081	AV

Note: Measure Level (dB μ V/m) = Reading Level (dB μ V) + Factor (dB)

Factor (dB) = Cable Loss (dB) + Antenna Factor (dB/m) - Pre_Amplifier Gain (dB)

Site: WZ-AC2	Time: 2020/08/30 - 11:56
Limit: FCC_Part15.209_RE(3m)	Engineer: Hyde Yu
Probe: WZ-AC2_BBHA9120D_1-18GHz	Polarity: Horizontal
EUT: AC1200 Wi-Fi Range Extender	Power: AC 120V/60Hz
Test Mode: Transmit by 802.11a at Channel 5500MHz	

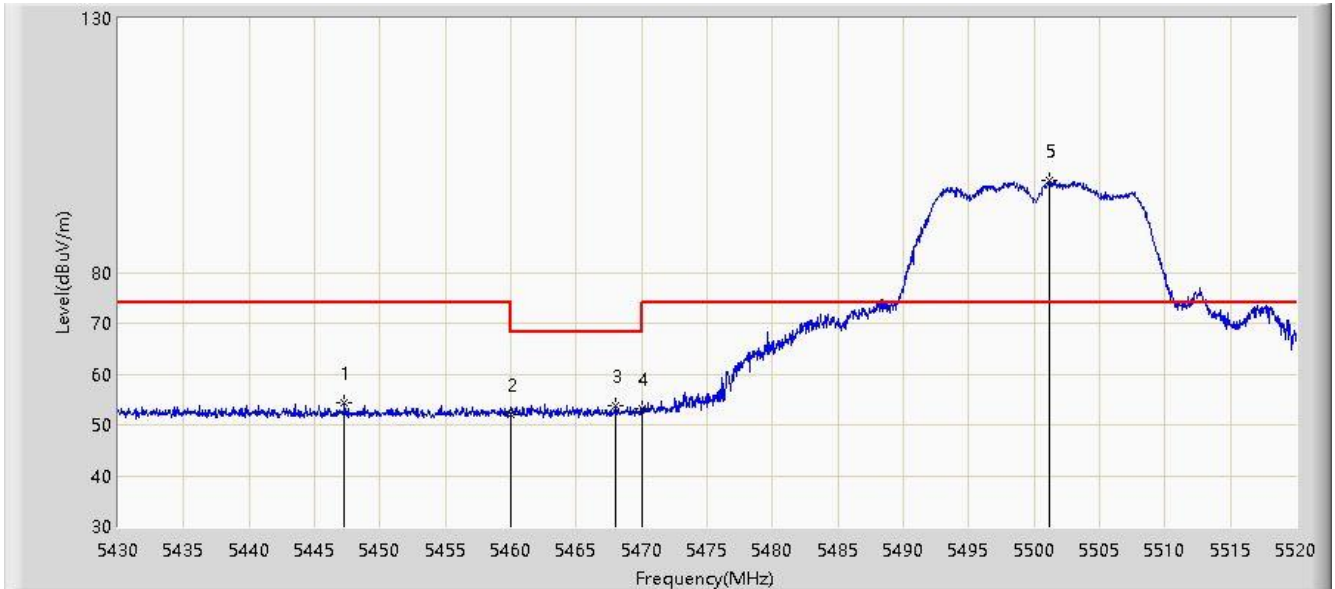

No	Flag	Mark	Frequency (MHz)	Measure Level (dBuV/m)	Reading Level (dBuV)	Margin (dB)	Limit (dBuV/m)	Factor (dB)	Type
1			5447.280	54.331	53.954	-19.669	74.000	0.377	PK
2			5460.000	52.037	51.758	-21.963	74.000	0.279	PK
3			5468.025	53.793	53.532	-14.407	68.200	0.261	PK
4			5470.000	53.071	52.814	-15.129	68.200	0.257	PK
5		*	5501.190	98.012	97.761	N/A	N/A	0.251	PK

Note: Measure Level (dB μ V/m) = Reading Level (dB μ V) + Factor (dB)

Factor (dB) = Cable Loss (dB) + Antenna Factor (dB/m) - Pre_Amplifier Gain (dB)

Site: WZ-AC2	Time: 2020/08/30 - 11:55
Limit: FCC_Part15.209_RE(3m)	Engineer: Hyde Yu
Probe: WZ-AC2_BBHA9120D_1-18GHz	Polarity: Horizontal
EUT: AC1200 Wi-Fi Range Extender	Power: AC 120V/60Hz
Test Mode: Transmit by 802.11a at Channel 5500MHz	

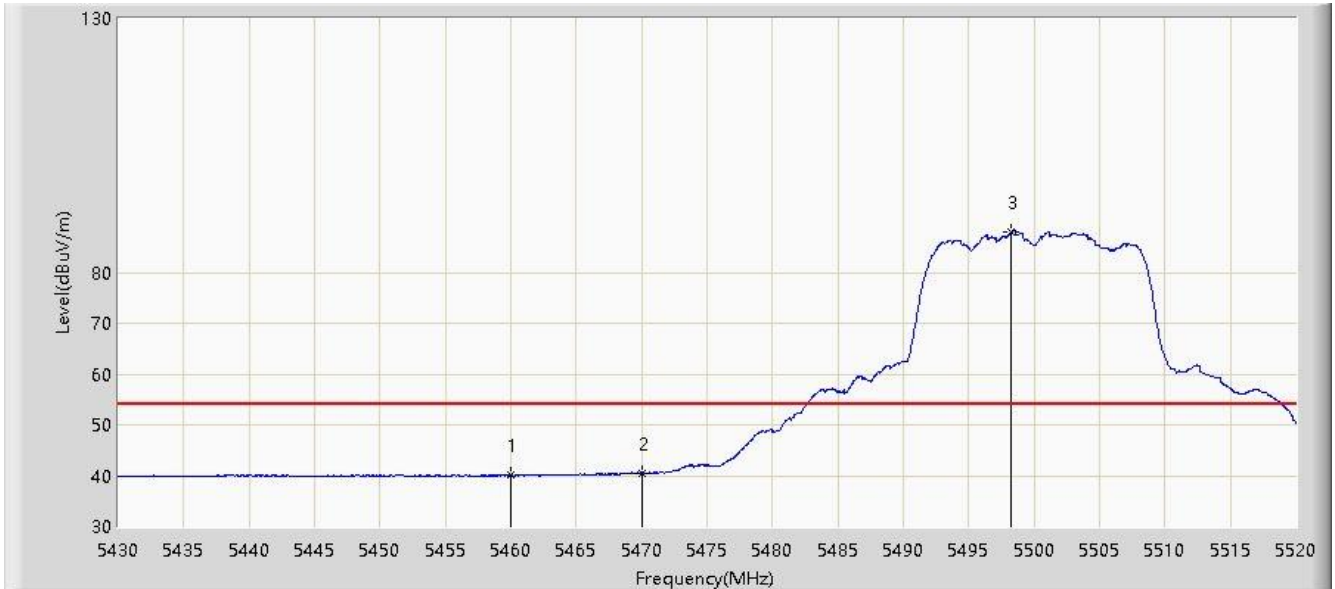

No	Flag	Mark	Frequency (MHz)	Measure Level (dBuV/m)	Reading Level (dBuV)	Margin (dB)	Limit (dBuV/m)	Factor (dB)	Type
1			5460.000	40.065	39.786	-13.935	54.000	0.279	AV
2			5470.000	40.554	40.297	-13.446	54.000	0.257	AV
3		*	5498.265	87.962	87.704	N/A	N/A	0.258	AV

Note: Measure Level (dBuV/m) = Reading Level (dBuV) + Factor (dB)

Factor (dB) = Cable Loss (dB) + Antenna Factor (dB/m) - Pre_Amplifier Gain (dB)

Site: WZ-AC2	Time: 2020/08/30 - 11:50
Limit: FCC_Part15.209_RE(3m)	Engineer: Hyde Yu
Probe: WZ-AC2_BBHA9120D_1-18GHz	Polarity: Vertical
EUT: AC1200 Wi-Fi Range Extender	Power: AC 120V/60Hz
Test Mode: Transmit by 802.11a at Channel 5500MHz	



No	Flag	Mark	Frequency (MHz)	Measure Level (dBuV/m)	Reading Level (dBuV)	Margin (dB)	Limit (dBuV/m)	Factor (dB)	Type
1			5459.745	60.945	60.666	-13.055	74.000	0.280	PK
2			5460.000	59.535	59.256	-14.465	74.000	0.279	PK
3			5469.240	66.959	66.700	-1.241	68.200	0.258	PK
4			5470.000	65.801	65.544	-2.399	68.200	0.257	PK
5		*	5501.145	114.363	114.112	N/A	N/A	0.250	PK

Note: Measure Level (dB μ V/m) = Reading Level (dB μ V) + Factor (dB)

Factor (dB) = Cable Loss (dB) + Antenna Factor (dB/m) - Pre_Amplifier Gain (dB)

Site: WZ-AC2	Time: 2020/08/30 - 11:53
Limit: FCC_Part15.209_RE(3m)	Engineer: Hyde Yu
Probe: WZ-AC2_BBHA9120D_1-18GHz	Polarity: Vertical
EUT: AC1200 Wi-Fi Range Extender	Power: AC 120V/60Hz
Test Mode: Transmit by 802.11a at Channel 5500MHz	

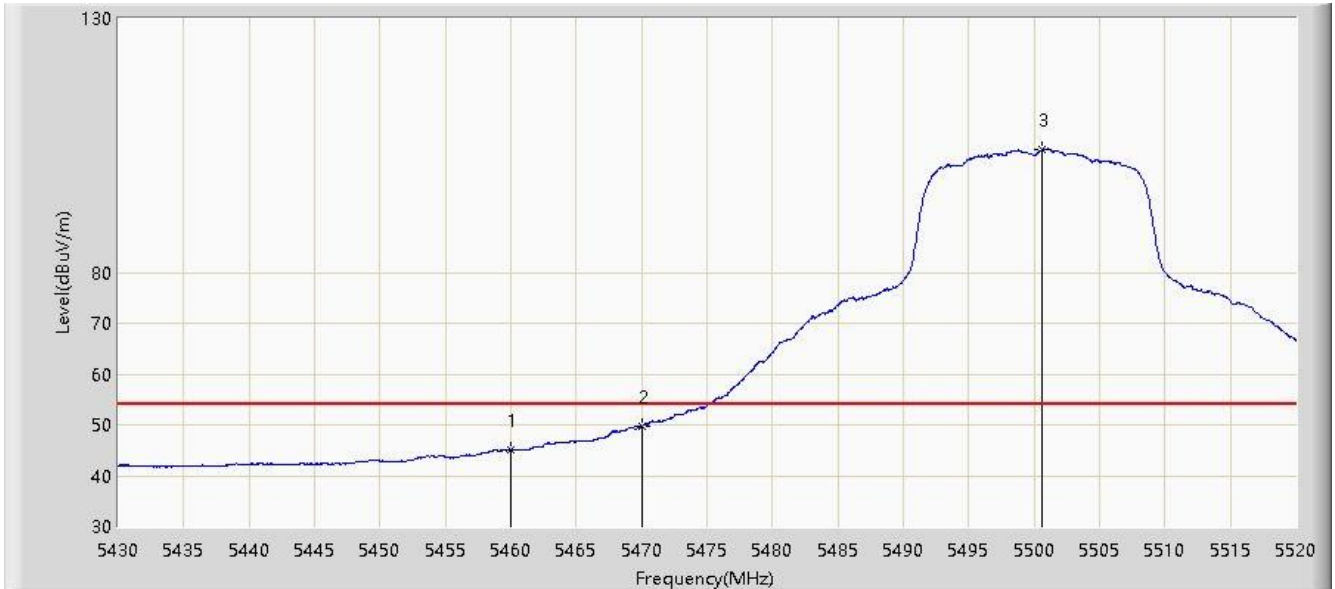

No	Flag	Mark	Frequency (MHz)	Measure Level (dBuV/m)	Reading Level (dBuV)	Margin (dB)	Limit (dBuV/m)	Factor (dB)	Type
1			5460.000	45.079	44.800	-8.921	54.000	0.279	AV
2			5470.000	49.775	49.518	-4.225	54.000	0.257	AV
3		*	5500.605	104.142	103.890	N/A	N/A	0.252	AV

Note: Measure Level (dBuV/m) = Reading Level (dBuV) + Factor (dB)

Factor (dB) = Cable Loss (dB) + Antenna Factor (dB/m) - Pre_Amplifier Gain (dB)

Site: WZ-AC2	Time: 2020/08/30 - 12:14
Limit: FCC_Part15.209_RE(3m)	Engineer: Hyde Yu
Probe: WZ-AC2_BBHA9120D_1-18GHz	Polarity: Horizontal
EUT: AC1200 Wi-Fi Range Extender	Power: AC 120V/60Hz
Test Mode: Transmit by 802.11a at Channel 5700MHz	

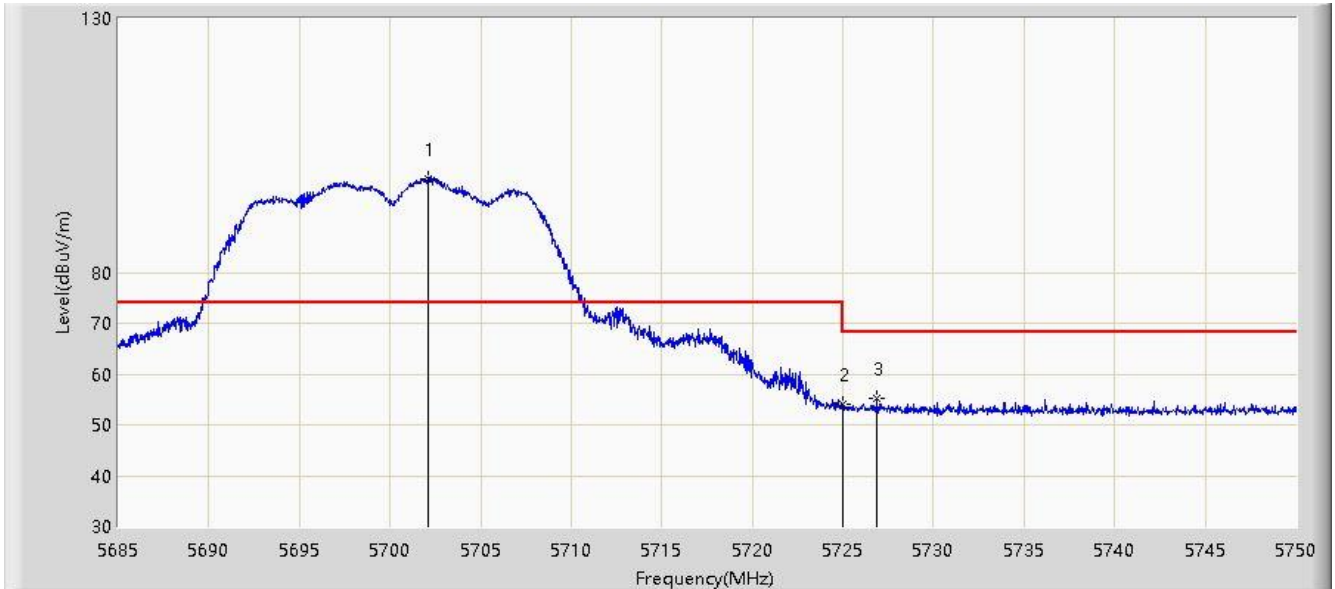

No	Flag	Mark	Frequency (MHz)	Measure Level (dBuV/m)	Reading Level (dBuV)	Margin (dB)	Limit (dBuV/m)	Factor (dB)	Type
1		*	5702.095	98.510	97.186	N/A	N/A	1.325	PK
2			5725.000	53.968	52.535	-14.232	68.200	1.433	PK
3			5726.893	55.291	53.873	-12.909	68.200	1.418	PK

Note: Measure Level (dB μ V/m) = Reading Level (dB μ V) + Factor (dB)

Factor (dB) = Cable Loss (dB) + Antenna Factor (dB/m) - Pre_Amplifier Gain (dB)

Site: WZ-AC2	Time: 2020/08/30 - 12:11
Limit: FCC_Part15.209_RE(3m)	Engineer: Hyde Yu
Probe: WZ-AC2_BBHA9120D_1-18GHz	Polarity: Vertical
EUT: AC1200 Wi-Fi Range Extender	Power: AC 120V/60Hz
Test Mode: Transmit by 802.11a at Channel 5700MHz	



No	Flag	Mark	Frequency (MHz)	Measure Level (dBuV/m)	Reading Level (dBuV)	Margin (dB)	Limit (dBuV/m)	Factor (dB)	Type
1		*	5703.005	111.243	109.892	N/A	N/A	1.351	PK
2			5725.000	62.786	61.353	-5.414	68.200	1.433	PK
3			5726.015	65.569	64.148	-2.631	68.200	1.421	PK

Note: Measure Level (dB μ V/m) = Reading Level (dB μ V) + Factor (dB)

Factor (dB) = Cable Loss (dB) + Antenna Factor (dB/m) - Pre_Amplifier Gain (dB)

Site: WZ-AC2	Time: 2020/08/22 - 12:06
Limit: FCC_Part15.407_RE(3m)	Engineer: Hyde Yu
Probe: WZ-AC2_BBHA9120D_1-18GHz	Polarity: Horizontal
EUT: AC1200 Wi-Fi Range Extender	Power: AC 120V/60Hz
Test Mode: Transmit by 802.11a at Channel 5745MHz	

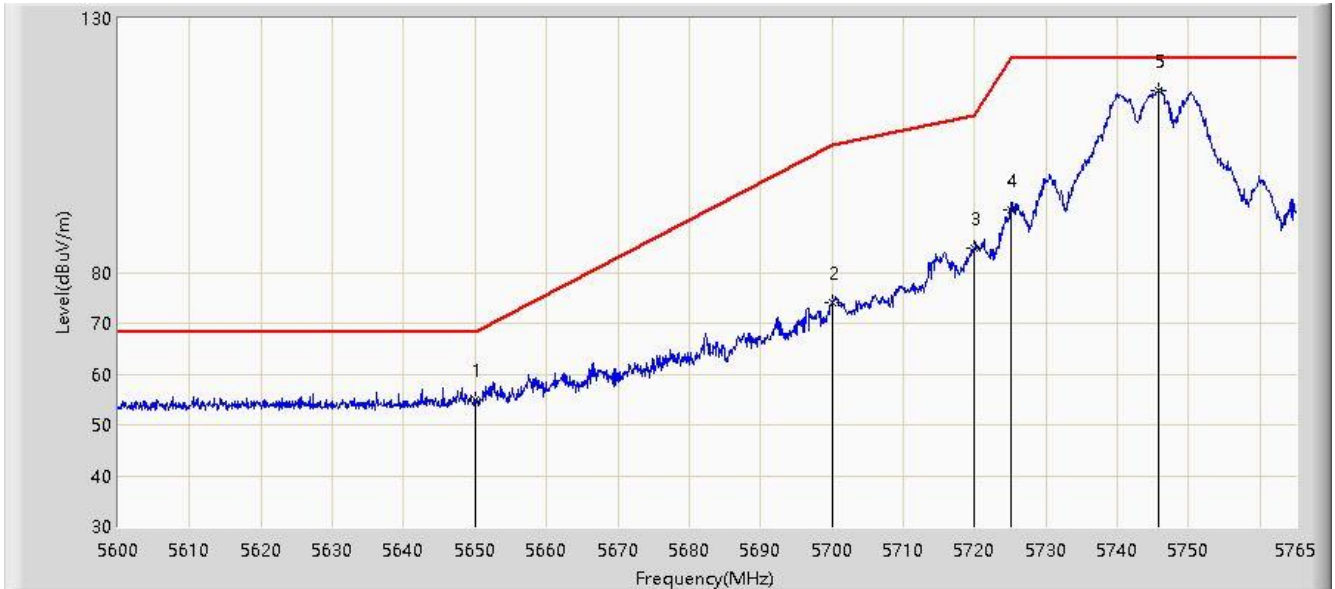

No	Flag	Mark	Frequency (MHz)	Measure Level (dBuV/m)	Reading Level (dBuV)	Margin (dB)	Limit (dBuV/m)	Factor (dB)	Type
1			5650.000	54.824	53.451	-13.376	68.200	1.373	PK
2			5700.000	73.921	72.657	-31.279	105.200	1.264	PK
3			5720.000	84.886	83.424	-25.914	110.800	1.462	PK
4			5725.000	92.343	90.910	-29.857	122.200	1.433	PK
5		*	5745.695	115.919	114.478	N/A	N/A	1.441	PK

Note: Measure Level (dB μ V/m) = Reading Level (dB μ V) + Factor (dB)

Factor (dB) = Cable Loss (dB) + Antenna Factor (dB/m) - Pre_Amplifier Gain (dB)

Site: WZ-AC2	Time: 2020/08/22 - 12:09
Limit: FCC_Part15.407_RE(3m)	Engineer: Hyde Yu
Probe: WZ-AC2_BBHA9120D_1-18GHz	Polarity: Vertical
EUT: AC1200 Wi-Fi Range Extender	Power: AC 120V/60Hz
Test Mode: Transmit by 802.11a at Channel 5745MHz	

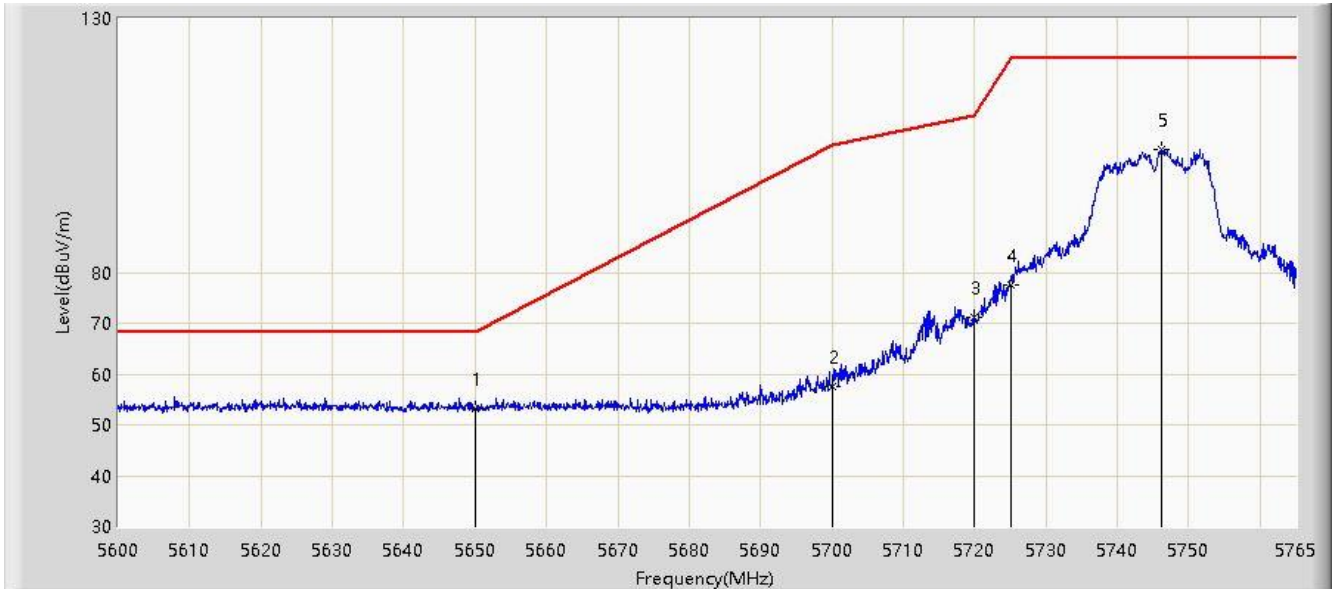

No	Flag	Mark	Frequency (MHz)	Measure Level (dBuV/m)	Reading Level (dBuV)	Margin (dB)	Limit (dBuV/m)	Factor (dB)	Type
1		*	5650.000	53.136	51.763	-15.064	68.200	1.373	PK
2			5700.000	57.577	56.313	-47.623	105.200	1.264	PK
3			5720.000	71.179	69.717	-39.621	110.800	1.462	PK
4			5725.000	77.530	76.097	-44.670	122.200	1.433	PK
5			5746.107	104.103	102.652	N/A	N/A	1.451	PK

Note: Measure Level (dB μ V/m) = Reading Level (dB μ V) + Factor (dB)

Factor (dB) = Cable Loss (dB) + Antenna Factor (dB/m) - Pre_Amplifier Gain (dB)

Site: WZ-AC2	Time: 2020/08/22 - 12:11
Limit: FCC_Part15.407_RE(3m)	Engineer: Hyde Yu
Probe: WZ-AC2_BBHA9120D_1-18GHz	Polarity: Horizontal
EUT: AC1200 Wi-Fi Range Extender	Power: AC 120V/60Hz
Test Mode: Transmit by 802.11a at Channel 5825MHz	

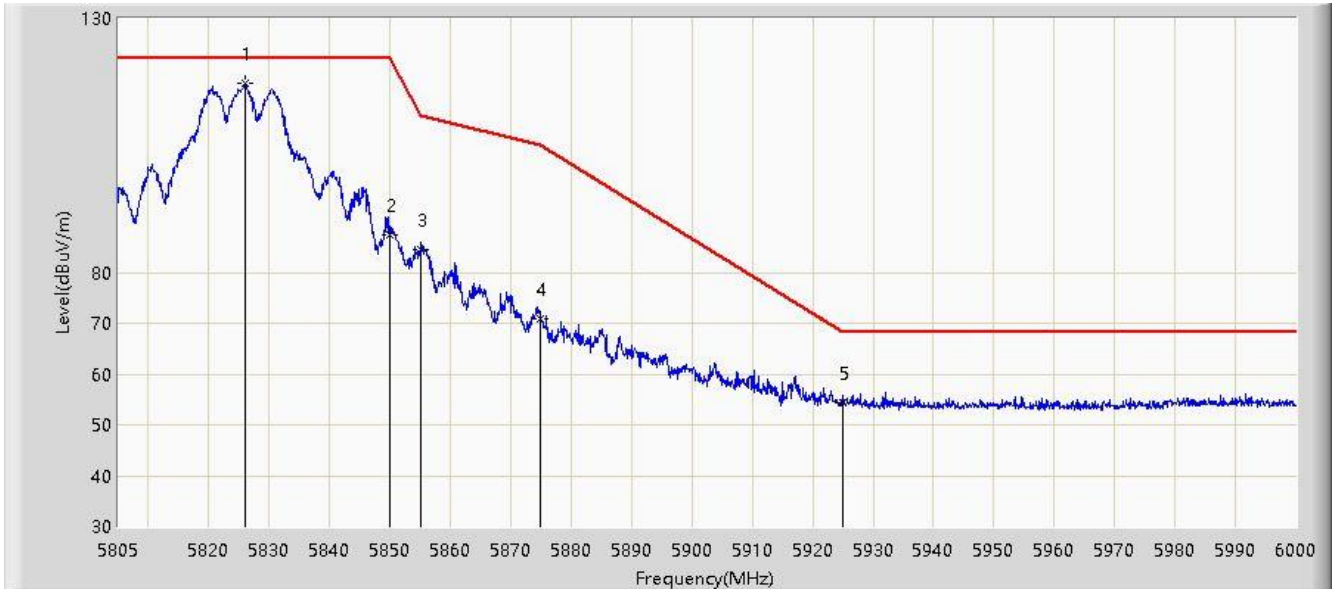

No	Flag	Mark	Frequency (MHz)	Measure Level (dBuV/m)	Reading Level (dBuV)	Margin (dB)	Limit (dBuV/m)	Factor (dB)	Type
1		*	5825.962	117.126	115.556	N/A	N/A	1.570	PK
2			5850.000	87.518	85.725	-34.682	122.200	1.792	PK
3			5855.000	84.398	82.596	-26.402	110.800	1.802	PK
4			5875.000	70.852	68.981	-34.348	105.200	1.872	PK
5			5925.000	54.439	52.370	-13.761	68.200	2.069	PK

Note: Measure Level (dB μ V/m) = Reading Level (dB μ V) + Factor (dB)

Factor (dB) = Cable Loss (dB) + Antenna Factor (dB/m) - Pre_Amplifier Gain (dB)

Site: WZ-AC2	Time: 2020/08/22 - 12:12
Limit: FCC_Part15.407_RE(3m)	Engineer: Hyde Yu
Probe: WZ-AC2_BBHA9120D_1-18GHz	Polarity: Vertical
EUT: AC1200 Wi-Fi Range Extender	Power: AC 120V/60Hz
Test Mode: Transmit by 802.11a at Channel 5825MHz	

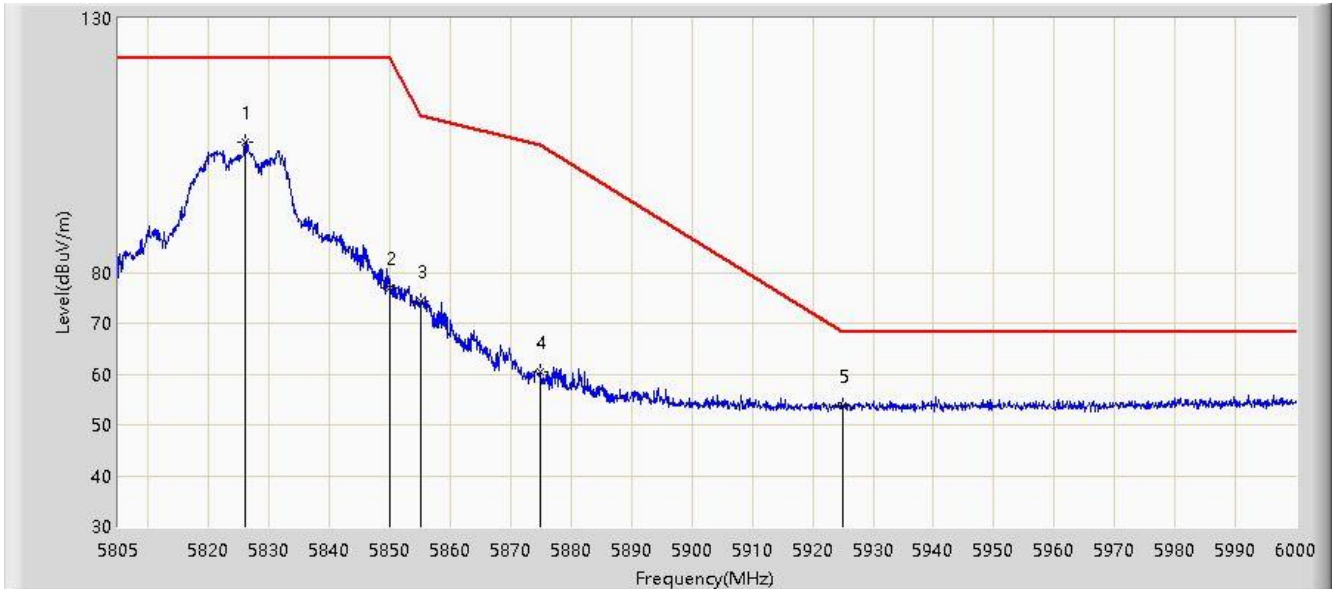

No	Flag	Mark	Frequency (MHz)	Measure Level (dBuV/m)	Reading Level (dBuV)	Margin (dB)	Limit (dBuV/m)	Factor (dB)	Type
1			5825.962	105.602	104.032	N/A	N/A	1.570	PK
2			5850.000	77.062	75.269	-45.138	122.200	1.792	PK
3			5855.000	74.309	72.507	-36.491	110.800	1.802	PK
4			5875.000	60.519	58.648	-44.681	105.200	1.872	PK
5		*	5925.000	53.831	51.762	-14.369	68.200	2.069	PK

Note: Measure Level (dB μ V/m) = Reading Level (dB μ V) + Factor (dB)

Factor (dB) = Cable Loss (dB) + Antenna Factor (dB/m) - Pre_Amplifier Gain (dB)

Site: WZ-AC2	Time: 2020/08/22 - 03:48
Limit: FCC_Part15.209_RE(3m)	Engineer: Hyde Yu
Probe: WZ-AC2_BBHA9120D_1-18GHz	Polarity: Horizontal
EUT: AC1200 Wi-Fi Range Extender	Power: AC 120V/60Hz
Test Mode: Transmit by 802.11ac-VHT20 at channel 5180MHz	

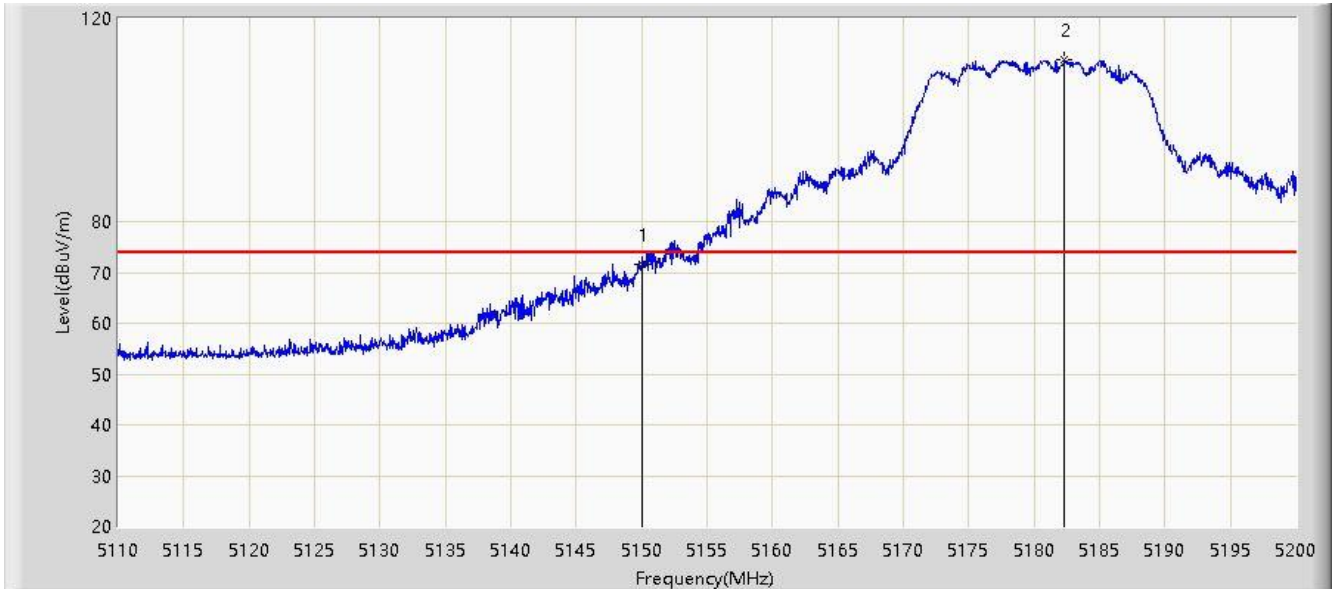

No	Flag	Mark	Frequency (MHz)	Measure Level (dBuV/m)	Reading Level (dBuV)	Margin (dB)	Limit (dBuV/m)	Factor (dB)	Type
1			5150.000	71.683	71.281	-2.317	74.000	0.402	PK
2		*	5182.315	111.879	111.551	N/A	N/A	0.327	PK

Note: Measure Level (dB μ V/m) = Reading Level (dB μ V) + Factor (dB)

Factor (dB) = Cable Loss (dB) + Antenna Factor (dB/m) - Pre_Amplifier Gain (dB)