



FCC RF Test Report

APPLICANT : TP-LINK TECHNOLOGIES CO., LTD.
EQUIPMENT : AC750 Wi-Fi Range Extender with Smart Plug
BRAND NAME : TP-LINK
MODEL NAME : RE270K
FCC ID : TE7RE270K
STANDARD : FCC Part 15 Subpart C §15.247
CLASSIFICATION : (DTS) Digital Transmission System

The product was received on Aug. 30, 2016 and testing was completed on Sep. 18, 2016. We, SPORTON INTERNATIONAL (SHENZHEN) INC., would like to declare that the tested sample has been evaluated in accordance with the test procedures and has been in compliance with the applicable technical standards.

The test results in this report apply exclusively to the tested model / sample. Without written approval of SPORTON INTERNATIONAL (SHENZHEN) INC., the test report shall not be reproduced except in full.

Prepared by: Ken Chen / Manager

Approved by: Jones Tsai / Manager



SPORTON INTERNATIONAL (SHENZHEN) INC.

**1F & 2F, Building A, Morning Business Center, No. 4003 ShiGu Rd., Xili Town,
Nanshan District, Shenzhen, Guangdong, P. R. China**



TABLE OF CONTENTS

REVISION HISTORY 3

SUMMARY OF TEST RESULT 4

1. GENERAL DESCRIPTION 5

 1.1 Applicant 5

 1.2 Manufacturer 5

 1.3 Product Feature of Equipment Under Test 5

 1.4 Product Specification of Equipment Under Test 6

 1.5 Modification of EUT 6

 1.6 Testing Location 7

 1.7 Applicable Standards 8

2. TEST CONFIGURATION OF EQUIPMENT UNDER TEST 9

 2.1 Carrier Frequency and Channel 9

 2.2 Test Mode 10

 2.3 Connection Diagram of Test System 11

 2.4 Support Unit used in test configuration and system 12

 2.5 EUT Operation Test Setup 12

 2.6 Measurement Results Explanation Example 13

3. TEST RESULT 14

 3.1 6dB and 99% Bandwidth Measurement 14

 3.2 Output Power Measurement 16

 3.3 Power Spectral Density Measurement 18

 3.4 Conducted Band Edges and Spurious Emission Measurement 20

 3.5 Radiated Band Edges and Spurious Emission Measurement 45

 3.6 AC Conducted Emission Measurement 49

 3.7 Antenna Requirements 53

4. LIST OF MEASURING EQUIPMENT 54

5. UNCERTAINTY OF EVALUATION 55

APPENDIX A. CONDUCTED TEST RESULTS

APPENDIX B. RADIATED TEST RESULTS

APPENDIX C. DUTY CYCLE PLOTS

APPENDIX D. SETUP PHOTOGRAPHS



Revision History

REPORT NO.	VERSION	DESCRIPTION	ISSUED DATE
FR683003A	Rev. 01	Initial issue of report	Oct. 26, 2016



Summary of Test RESULT

Report Section	FCC Rule	IC Rule	Description	Limit	Result	Remark
3.1	15.247(a)(2)	RSS-247 5.2(1)	6dB Bandwidth	≥ 0.5MHz	Pass	-
3.1	-	RSS-Gen 6.6	99% Bandwidth	-	Pass	-
3.2	15.247(b)	RSS-247 A5.4(4)	Power Output Measurement	≤ 30dBm	Pass	-
3.3	15.247(e)	RSS-247 5.2(2)	Power Spectral Density	≤ 8dBm/3kHz	Pass	-
3.4	15.247(d)	RSS-247 5.5	Conducted Band Edges	≤ 30dBc	Pass	-
			Conducted Spurious Emission		Pass	-
3.5	15.247(d)	RSS-247 5.5	Radiated Band Edges and Radiated Spurious Emission	15.209(a) & 15.247(d)	Pass	Under limit 0.24 dB at 2390.000 MHz
3.6	15.207	RSS-GEN 8.8	AC Conducted Emission	15.207(a)	Pass	Under limit 16.41 dB at 0.620 MHz
3.7	15.203 & 15.247(b)	N/A	Antenna Requirement	N/A	Pass	-



1. General Description

1.1 Applicant

TP-LINK TECHNOLOGIES CO., LTD.

Building 24 (floors 1,3,4,5) and 28 (floors1-4) Central Science and Technology Park, Shennan Rd, Nanshan, Shenzhen, China

1.2 Manufacturer

TP-LINK TECHNOLOGIES CO., LTD.

Building 24 (floors 1,3,4,5) and 28 (floors1-4) Central Science and Technology Park, Shennan Rd, Nanshan, Shenzhen, China

1.3 Product Feature of Equipment Under Test

Product Feature	
Equipment	AC750 Wi-Fi Range Extender with Smart Plug
Brand Name	TP-LINK
Model Name	RE270K
FCC ID	TE7RE270K
EUT supports Radios application	WLAN2.4GHz 802.11b/g/n HT20/HT40 WLAN5GHz 802.11a/n HT20/HT40 WLAN5GHz 80211ac VHT20/VHT40/VHT80
EUT Stage	Production Unit

Remark: The above EUT's information was declared by manufacturer. Please refer to the specifications or user's manual for more detailed description.



1.4 Product Specification of Equipment Under Test

Standards-related Product Specification										
Tx/Rx Channel Frequency Range	2412 MHz ~ 2462 MHz									
Maximum (Average) Output Power to antenna	802.11b : 23.52 dBm (0.2249 W) 802.11g : 22.53 dBm (0.1791 W) 802.11n HT20 : 22.57 dBm (0.1807 W) 802.11n HT40 : 20.19 dBm (0.1045 W)									
99% Occupied Bandwidth	802.11b : 13.89 MHz 802.11g : 25.32 MHz 802.11n HT20 : 28.42 MHz 802.11n HT40 : 37.76 MHz									
Antenna Type / Gain	<Chain Port 1> Dipole Antenna with gain 1.91 dBi <Chain Port 2> Dipole Antenna with gain 1.94 dBi									
Type of Modulation	802.11b : DSSS (DBPSK / DQPSK / CCK) 802.11g/n : OFDM (BPSK / QPSK / 16QAM / 64QAM)									
Antenna Function for Transmitter	<table border="1"> <thead> <tr> <th></th> <th>Chain Port 1</th> <th>Chain Port 2</th> </tr> </thead> <tbody> <tr> <td>802.11 b/g/n SISO</td> <td>V</td> <td>V</td> </tr> <tr> <td>802.11 b/g/n MIMO</td> <td>V</td> <td>V</td> </tr> </tbody> </table>		Chain Port 1	Chain Port 2	802.11 b/g/n SISO	V	V	802.11 b/g/n MIMO	V	V
		Chain Port 1	Chain Port 2							
	802.11 b/g/n SISO	V	V							
802.11 b/g/n MIMO	V	V								

Note: MIMO Chain Port 1+2 is a calculated result from sum of the power MIMO Chain Port 1 and MIMO Chain Port 2.

1.5 Modification of EUT

No modifications are made to the EUT during all test items.



1.6 Testing Location

Test Site	SPORTON INTERNATIONAL (SHENZHEN) INC.	
Test Site Location	1F & 2F, Building A, Morning Business Center, No. 4003 ShiGu Rd., Xili Town, Nanshan District, Shenzhen, Guangdong, P. R. China TEL: +86-755-8637-9589 FAX: +86-755-8637-9595	
Test Site No.	Sporton Site No.	
	TH01-SZ	CO01-SZ

Test Site	SPORTON INTERNATIONAL (SHENZHEN) INC.	
Test Site Location	No. 3 Building, the third floor of south, Shahe River west, Fengzeyuan warehouse, Nanshan District, Shenzhen, Guangdong, P. R. China TEL: +86-755- 3320-2398	
Test Site No.	Sporton Site No.	FCC Registration No.
	03CH03-SZ	565805

Note: The test site complies with ANSI C63.4 2014 requirement.



1.7 Applicable Standards

According to the specifications of the manufacturer, the EUT must comply with the requirements of the following standards:

- ♦ FCC Part 15 Subpart C §15.247
- ♦ FCC KDB Publication No. 558074 D01 DTS Meas. Guidance v03r05
- ♦ FCC KDB 662911 D01 Multiple Transmitter Output v02r01.
- ♦ ANSI C63.10-2013

Remark:

1. All test items were verified and recorded according to the standards and without any deviation during the test.
2. This EUT has also been tested and complied with the requirements of FCC Part 15, Subpart B, recorded in a separate test report.



2. Test Configuration of Equipment Under Test

The EUT has been associated with peripherals and configuration operated in a manner tended to maximize its emission characteristics in a typical application. Frequency range investigated: conducted emission (150 kHz to 30 MHz) and radiated emission (9 kHz to the 10th harmonic of the highest fundamental frequency or to 40 GHz, whichever is lower). For radiated measurement, pre-scanned in three orthogonal panels, X, Y, Z. The worst cases (Y plane) were recorded in this report.

2.1 Carrier Frequency and Channel

Frequency Band	Channel	Freq. (MHz)	Channel	Freq. (MHz)
2400-2483.5 MHz	1	2412	7	2442
	2	2417	8	2447
	3	2422	9	2452
	4	2427	10	2457
	5	2432	11	2462
	6	2437		



2.2 Test Mode

Final test mode of conducted test items and radiated spurious emissions are considering the modulation and worse data rates as below table.

Single Antenna

Modulation	Data Rate
802.11b	1 Mbps
802.11g	6 Mbps
802.11n HT20	MCS0
802.11n HT40	MCS0

MIMO Antenna

Modulation	Data Rate
802.11b	1 Mbps
802.11g	6 Mbps
802.11n HT20	MCS0
802.11n HT40	MCS0

Test Cases	
AC Conducted Emission	Mode 1 : WLAN 2.4G Link (Client) + WLAN 2.4G Link (Master) + AC Load + RJ45 Link

2.3 Connection Diagram of Test System

<WLAN Tx Mode>

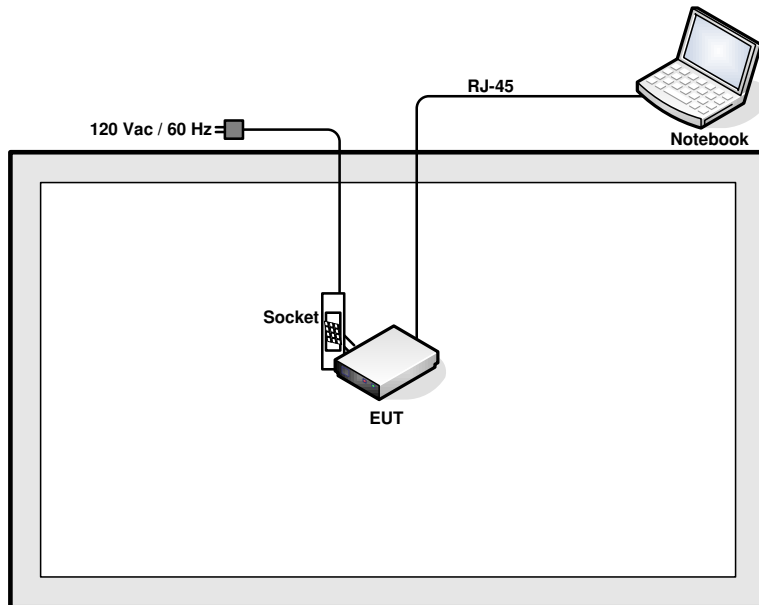

<AC Conducted Emission Mode>

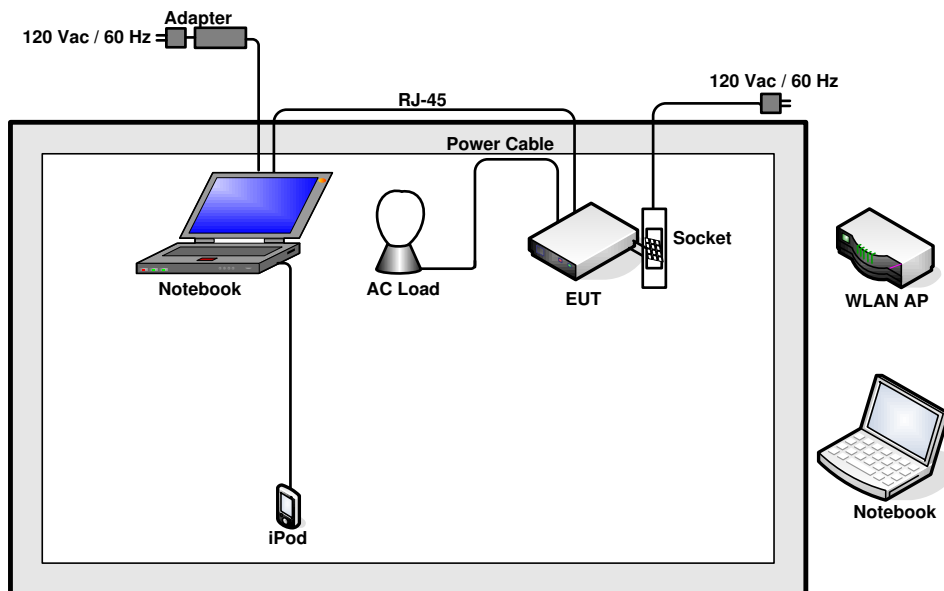



2.4 Support Unit used in test configuration and system

Item	Equipment	Trade Name	Model Name	FCC ID	Data Cable	Power Cord
1.	WLAN AP	D-Link	DIR-820L	KA2IR820LA1	N/A	Unshielded, 1.8 m
2.	Notebook	Lenovo	E450	FCC DoC	N/A	AC I/P: Unshielded, 1.2 m DC O/P: Shielded, 1.8 m
3.	Notebook	Lenovo	G480	FCC DoC	N/A	AC I/P: Unshielded, 1.2 m DC O/P: Shielded, 1.8 m
4.	iPod nano 8GB	Apple	MC690ZP/A	FCC DoC	Shielded, 1.2m	N/A
5.	AC Load	N/A	N/A	N/A	N/A	N/A
6.	Socket	N/A	N/A	N/A	N/A	N/A
7.	Power Cable	N/A	N/A	N/A	N/A	N/A

2.5 EUT Operation Test Setup

For WLAN function, the engineering test program was provided and enabled to make EUT continuous transmit/receive.

For AC power line conducted emissions, the EUT was set to connect with the notebook under large package sizes transmission.



2.6 Measurement Results Explanation Example

For all conducted test items:

The offset level is set in the spectrum analyzer to compensate the RF cable loss and attenuator factor between EUT conducted output port and spectrum analyzer. With the offset compensation, the spectrum analyzer reading level is exactly the EUT RF output level.

Example:

The spectrum analyzer offset is derived from RF cable loss and attenuator factor.

Offset = RF cable loss + attenuator factor.

Following shows an offset computation example with cable loss 5 dB and 10dB attenuator.

$$\begin{aligned} \text{Offset(dB)} &= \text{RF cable loss(dB)} + \text{attenuator factor(dB)}. \\ &= 5 + 10 = 15 \text{ (dB)} \end{aligned}$$

3. Test Result

3.1 6dB and 99% Bandwidth Measurement

3.1.1 Limit of 6dB and 99% Bandwidth

The minimum 6 dB bandwidth shall be at least 500 kHz.

3.1.2 Measuring Instruments

The measuring equipment is listed in the section 4 of this test report.

3.1.3 Test Procedures

1. The testing follows FCC KDB Publication No. 558074 DTS D01 Meas. Guidance v03r05.
2. The RF output of EUT was connected to the spectrum analyzer by RF cable and attenuator. The path loss was compensated to the results for each measurement.
3. Set to the maximum power setting and enable the EUT transmit continuously.
4. Make the measurement with the spectrum analyzer's resolution bandwidth (RBW) = 100 kHz. Set the Video bandwidth (VBW) = 300 kHz. In order to make an accurate measurement. The 6 dB bandwidth must be greater than 500 kHz.
5. For 99% Bandwidth Measurement, the spectrum analyzer's resolution bandwidth (RBW) = 1MHz and set the Video bandwidth (VBW) = 3MHz.
6. Measure and record the results in the test report.

3.1.4 Test Setup





3.1.5 Test Result of 6dB and 99% Occupied Bandwidth

Please refer to Appendix A.

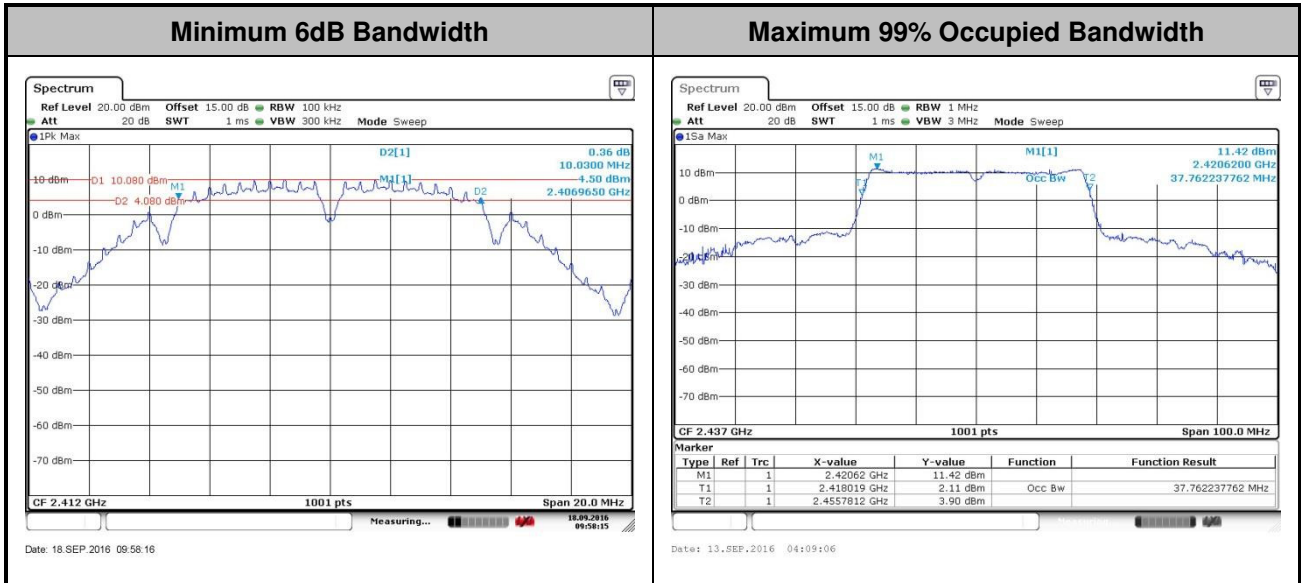

Note: The occupied channel bandwidth is maintained within the band of operation for all of the modulations.

3.2 Output Power Measurement

3.2.1 Limit of Output Power

For systems using digital modulation in the 2400-2483.5MHz, the limit for output power is 30dBm. If transmitting antenna with directional gain greater than 6dBi is used, the output power from the intentional radiator shall be reduced below the above stated value by the amount in dB that the directional gain of the antenna exceeds 6 dBi. In case of point-to-point operation, the limit has to be reduced by 1dB for every 3dB that the directional gain of the antenna exceeds 6dBi.

3.2.2 Measuring Instruments

The measuring equipment is listed in the section 4 of this test report.

3.2.3 Test Procedures

1. The testing follows the Measurement Procedure of FCC KDB No. 558074 DTS D01 Meas. Guidance v03r05 section 9.2.3.1 Method AVGPM.
2. The RF output of EUT was connected to the power meter by RF cable and attenuator. The path loss was compensated to the results for each measurement.
3. Set to the maximum power setting and enable the EUT transmit continuously.
4. Measure the conducted output power and record the results in the test report.
5. For MIMO mode, calculation method follows FCC KDB 662911 D01 Multiple Transmitter Output v02r01.

3.2.4 Test Setup

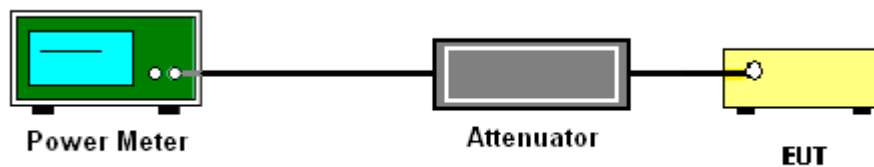



3.2.5 Test Result of Peak Output Power (Reporting Only)

Please refer to Appendix A.

3.2.6 Test Result of Average output Power

Please refer to Appendix A



3.3 Power Spectral Density Measurement

3.3.1 Limit of Power Spectral Density

The average power spectral density shall not be greater than 8dBm in any 3kHz band at any time interval of continuous transmission.

3.3.2 Measuring Instruments

The measuring equipment is listed in the section 4 of this test report.

3.3.3 Test Procedures

1. The testing follows Measurement Procedure 10.5 Method AVGPSD-2 of FCC KDB Publication No. 558074 D01 DTS Meas. Guidance v03r05.
2. The RF output of EUT was connected to the spectrum analyzer by RF cable and attenuator. The path loss was compensated to the results for each measurement.
3. Set to the maximum power setting and enable the EUT transmit continuously.
4. Make the measurement with the spectrum analyzer's resolution bandwidth (RBW) = 10 kHz. Video bandwidth VBW = 30 kHz In order to make an accurate measurement, set the span to 1.5 times DTS Channel Bandwidth. (6dB BW).
5. Number of points in sweep ≥ 2 Span / RBW. (This ensures that bin-to-bin spacing is \leq RBW/2, so that narrowband signals are not lost between frequency bins).
6. Detector = RMS, Sweep time = auto couple.
7. Trace average at least 100 traces in power averaging mode.
8. Add $10 \log(1/x)$, where x is the duty cycle, to the measured power in order to compute the average power during the actual transmission times. For example, add $10 \log(1/0.25) = 6$ dB if the duty cycle is 25 percent.
9. Measure and record the results in the test report. For MIMO mode, calculation method follows FCC KDB 662911 D01 Multiple Transmitter Output v02r01.
Method (c): Measure and add $10 \log(N_{ANT})$ dB.

With this technique, spectrum measurements are performed at each output of the device, but rather than summing the spectra or the spectral peaks across the outputs, the quantity $10 \log(N_{ANT})$ dB is added to each spectrum value before comparing to the emission limit. The addition of $10 \log(N_{ANT})$ dB serves to apportion the emission limit among the N_{ANT} outputs so that each output is permitted to contribute no more than $1/N_{ANT}^{th}$ of the PSD limit .

3.3.4 Test Setup

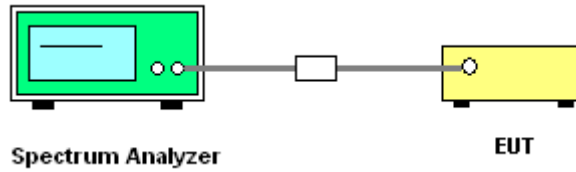

3.3.5 Test Result of Power Spectral Density

Please refer to Appendix A.

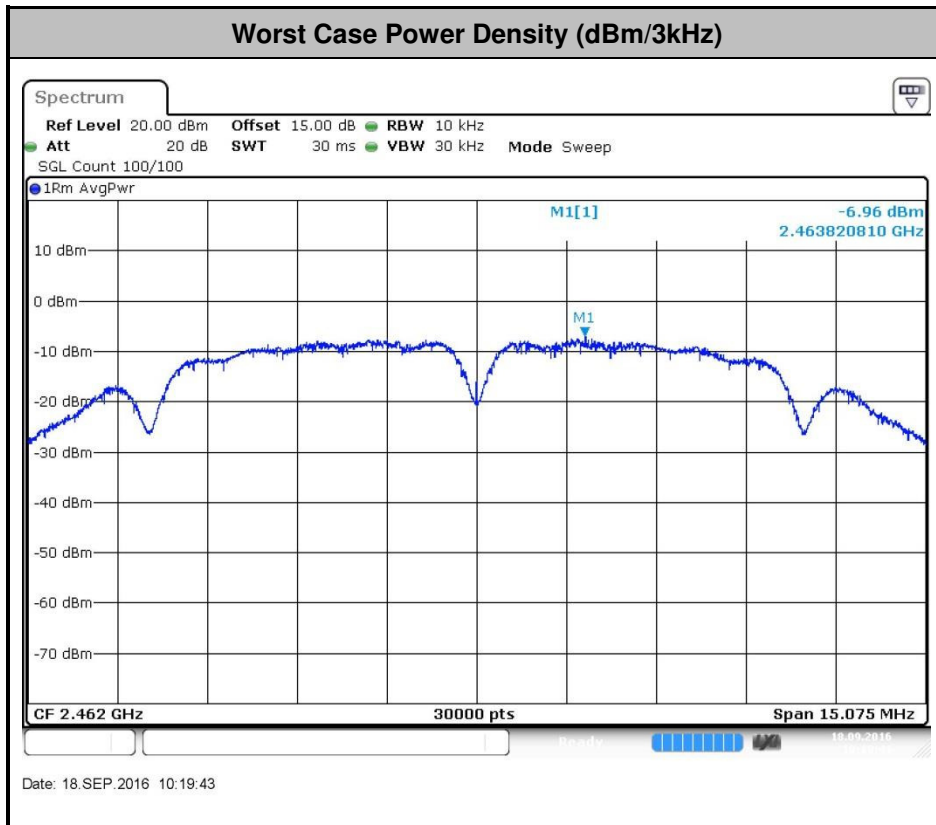

3.4 Conducted Band Edges and Spurious Emission Measurement

3.4.1 Limit of Conducted Band Edges and Spurious Emission Measurement

In any 100 kHz bandwidth outside of the authorized frequency band, the emissions which fall in the non-restricted bands shall be attenuated at least 20 dB / 30dB relative to the maximum PSD level in 100 kHz by RF conducted measurement and radiated emissions which fall in the restricted bands, as defined in Section 15.205(a), must also comply with the radiated emission limits specified in Section 15.209(a).

3.4.2 Measuring Instruments

The measuring equipment is listed in the section 4 of this test report.

3.4.3 Test Procedures

1. The testing follows FCC KDB Publication No. 558074 D01 DTS Meas. Guidance v03r05.
2. The RF output of EUT was connected to the spectrum analyzer by RF cable and attenuator. The path loss was compensated to the results for each measurement.
3. Set to the maximum power setting and enable the EUT transmit continuously.
4. Set RBW = 100 kHz, VBW=300 kHz, Peak Detector. Unwanted Emissions measured in any 100 kHz bandwidth outside of the authorized frequency band shall be attenuated by at least 20 dB relative to the maximum in-band peak PSD level in 100 kHz when maximum peak conducted output power procedure is used. If the transmitter complies with the conducted power limits based on the use of RMS averaging over a time interval, the attenuation required under this paragraph shall be 30 dB instead of 20 dB per 15.247(d).
5. Measure and record the results in the test report.
6. The RF fundamental frequency should be excluded against the limit line in the operating frequency band.

3.4.4 Test Setup

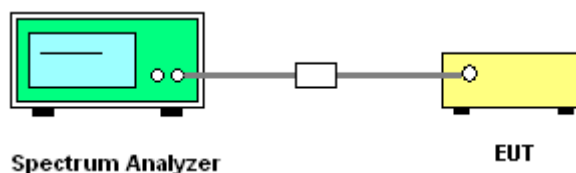



3.4.5 Test Result of Conducted Band Edges and Spurious Emission

Number of TX = 2, Chain Port 1 (Measured)

Number of TX :	2	Chain Port :	1
Test Mode :	802.11b	Temperature :	24~26°C
Test Band :	2.4GHz Low	Relative Humidity :	50~53%
Test Channel :	01	Test Engineer :	Sam Zheng

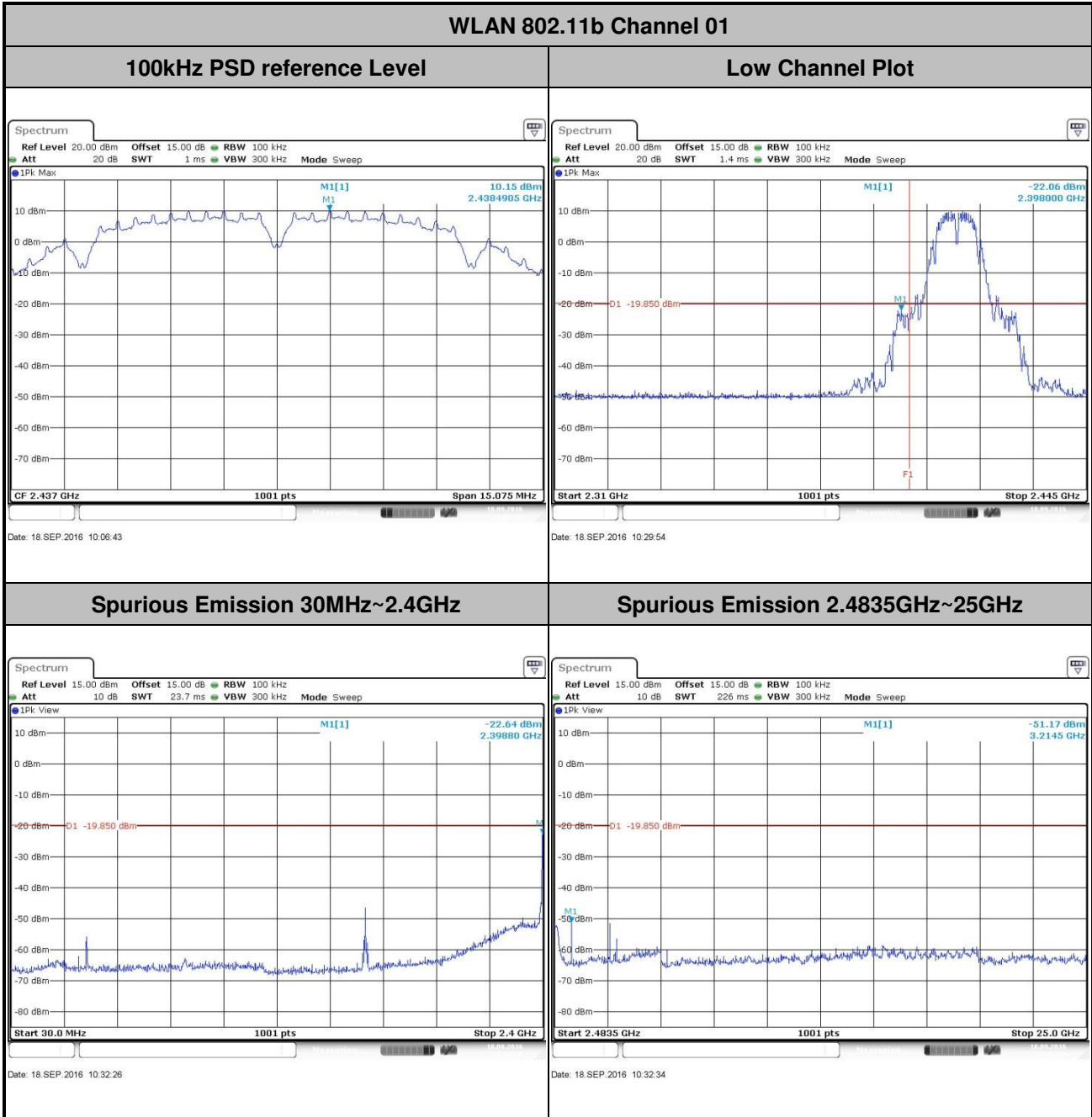



Number of TX :	2	Chain Port :	1
Test Mode :	802.11b	Temperature :	24~26°C
Test Band :	2.4GHz Mid	Relative Humidity :	50~53%
Test Channel :	06	Test Engineer :	Sam Zheng

WLAN 802.11b Channel 06

100kHz PSD reference Level

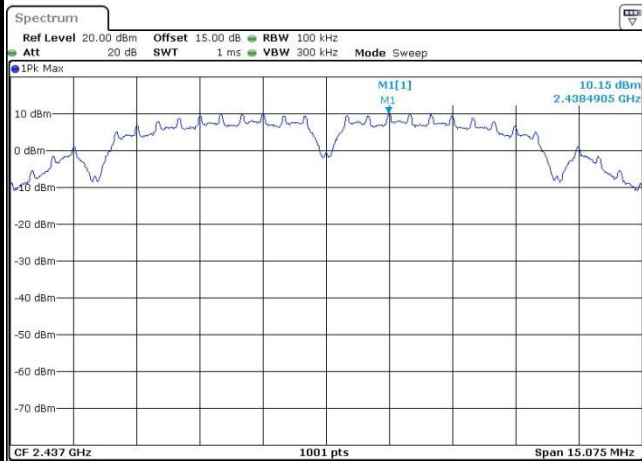

Date: 18.SEP.2016 10:06:43

Spurious Emission 30MHz~2.4GHz

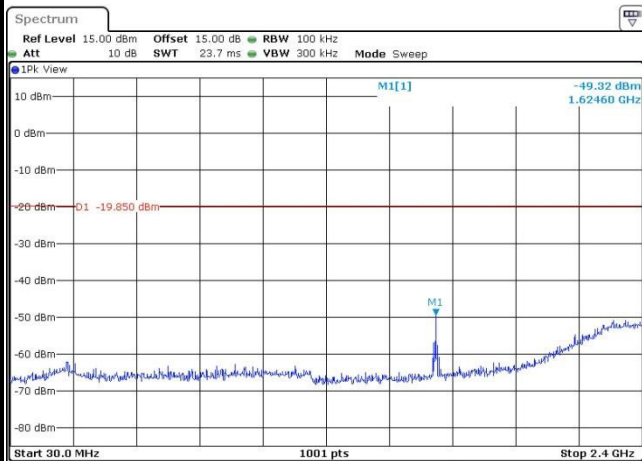

Date: 18.SEP.2016 10:14:53

Spurious Emission 2.4835GHz~25GHz

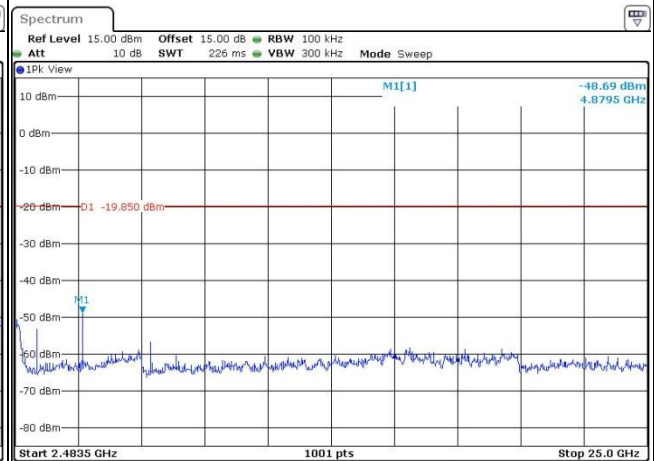

Date: 18.SEP.2016 10:15:01



Number of TX :	2	Chain Port :	1
Test Mode :	802.11b	Temperature :	24~26°C
Test Band :	2.4GHz High	Relative Humidity :	50~53%
Test Channel :	11	Test Engineer :	Sam Zheng

WLAN 802.11b Channel 11

100kHz PSD reference Level

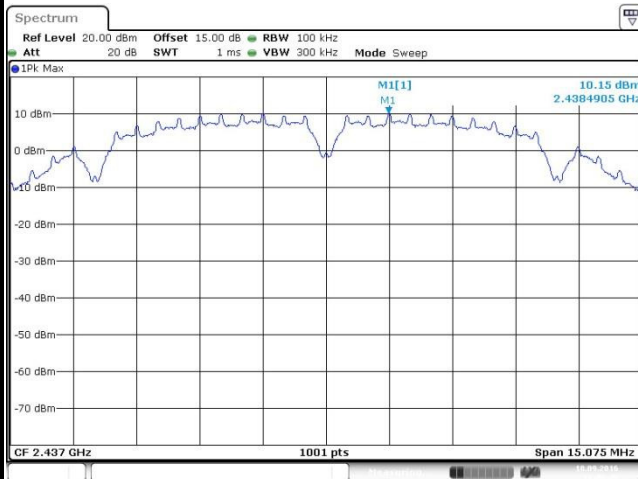

Date: 18.SEP.2016 10:06:43

High Channel Plot

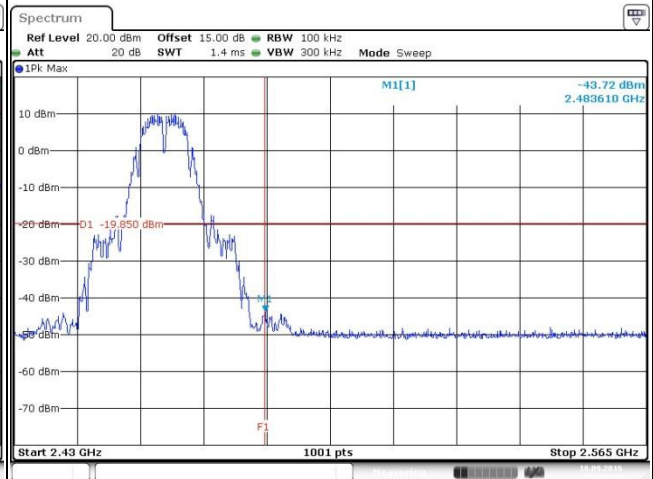

Date: 18.SEP.2016 10:22:41

Spurious Emission 30MHz~2.4GHz

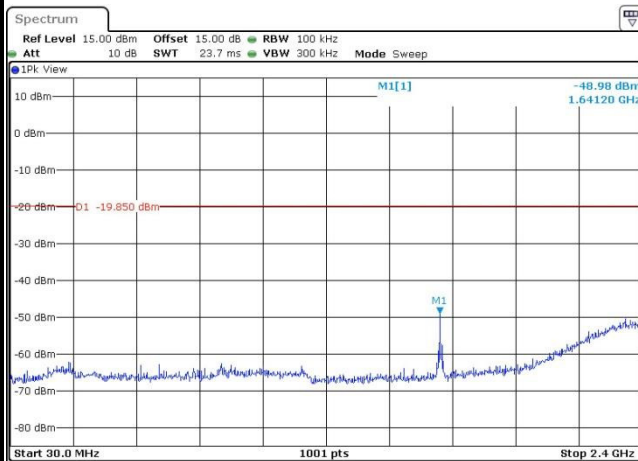

Date: 18.SEP.2016 10:24:07

Spurious Emission 2.4835GHz~25GHz

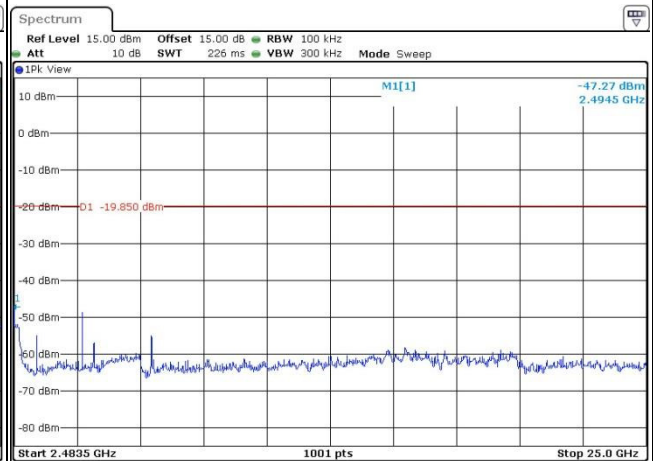

Date: 18.SEP.2016 10:24:15



Number of TX :	2	Chain Port :	1
Test Mode :	802.11g	Temperature :	24~26°C
Test Band :	2.4GHz Low	Relative Humidity :	50~53%
Test Channel :	01	Test Engineer :	Sam Zheng

WLAN 802.11g Channel 01

100kHz PSD reference Level

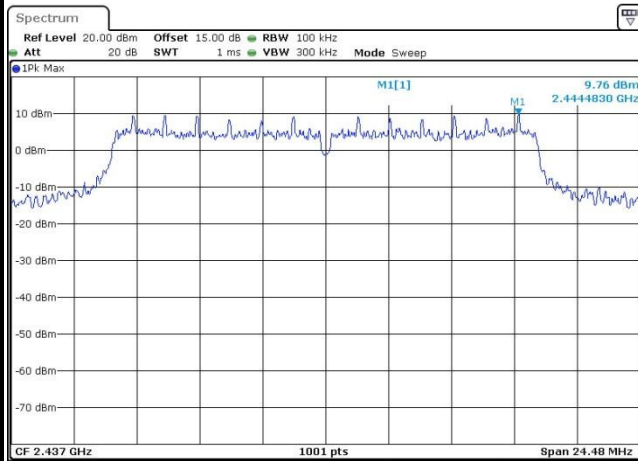

Date: 12.SEP.2016 02:04:22

Low Channel Plot

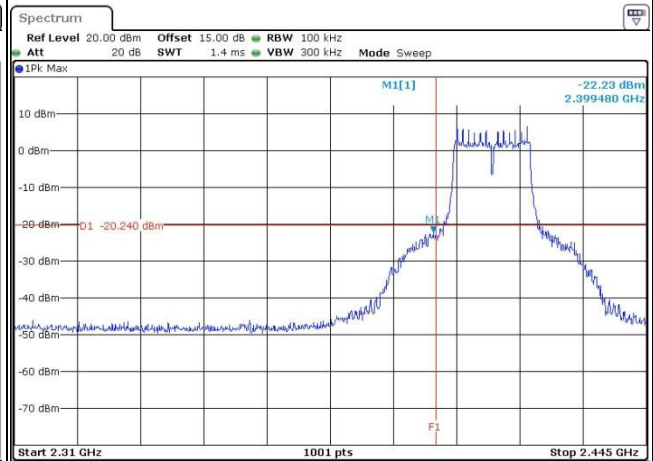

Date: 13.SEP.2016 04:55:11

Spurious Emission 30MHz~2.4GHz

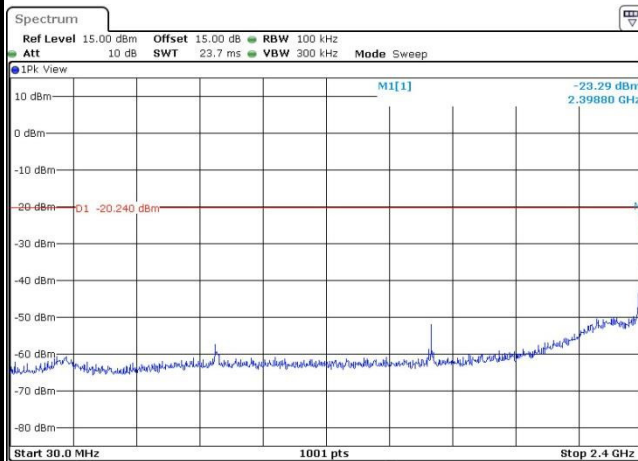

Date: 13.SEP.2016 04:56:54

Spurious Emission 2.4835GHz~25GHz

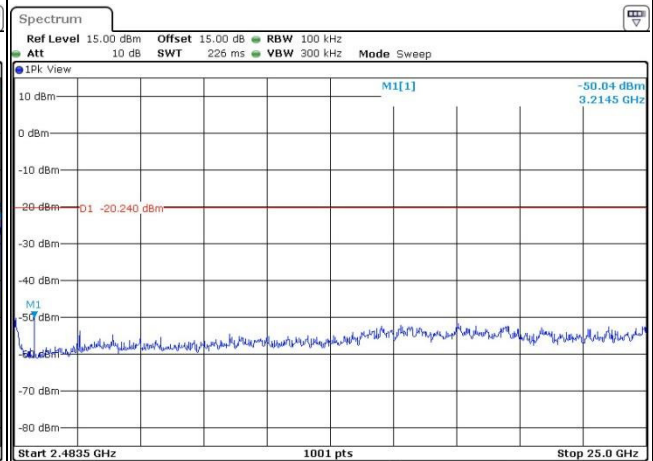

Date: 13.SEP.2016 04:57:03



Number of TX :	2	Chain Port :	1
Test Mode :	802.11g	Temperature :	24~26°C
Test Band :	2.4GHz Mid	Relative Humidity :	50~53%
Test Channel :	06	Test Engineer :	Sam Zheng

WLAN 802.11g Channel 06

100kHz PSD reference Level

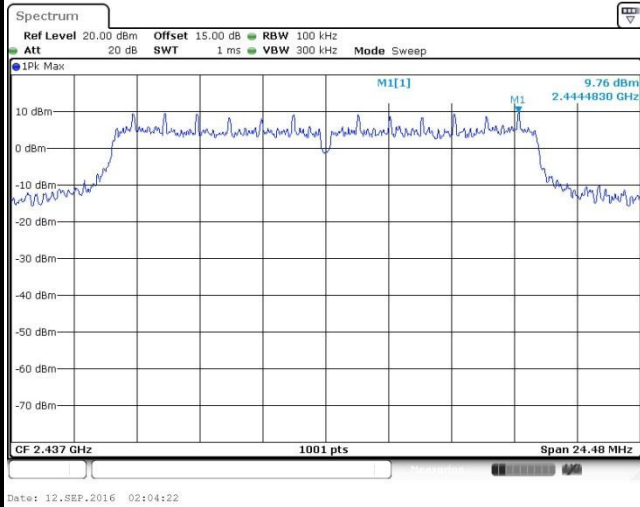

Spurious Emission 30MHz~2.4GHz

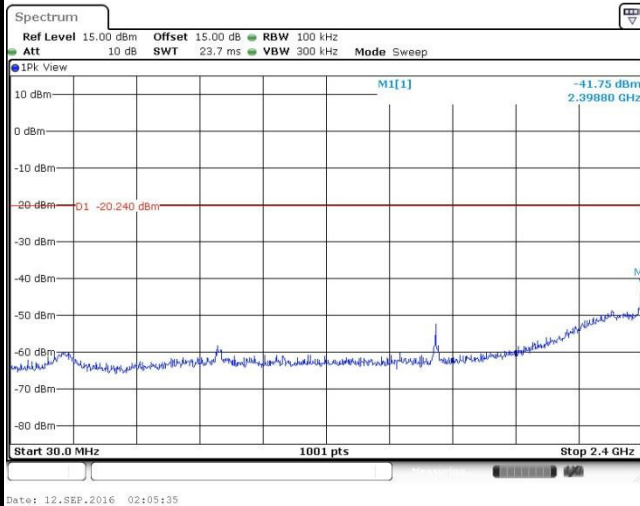

Spurious Emission 2.4835GHz~25GHz

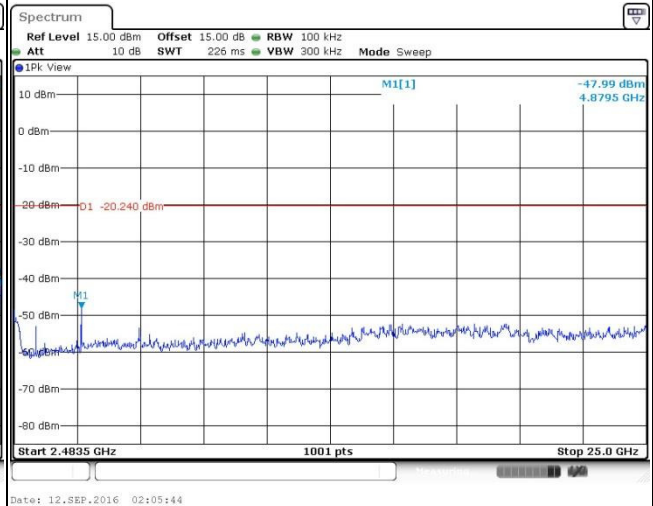



Number of TX :	2	Chain Port :	1
Test Mode :	802.11g	Temperature :	24~26°C
Test Band :	2.4GHz High	Relative Humidity :	50~53%
Test Channel :	11	Test Engineer :	Sam Zheng

WLAN 802.11g Channel 11

100kHz PSD reference Level

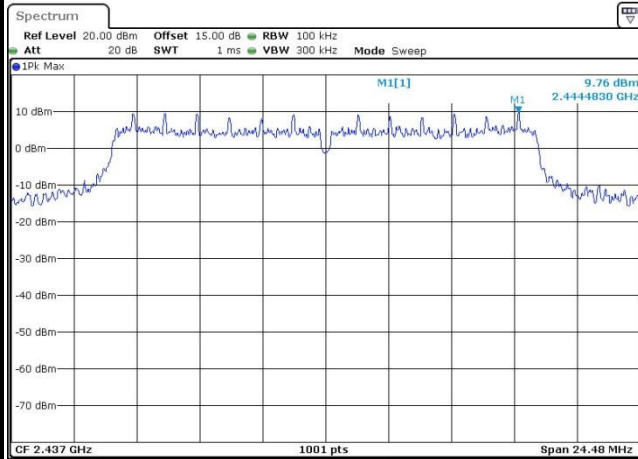

High Channel Plot

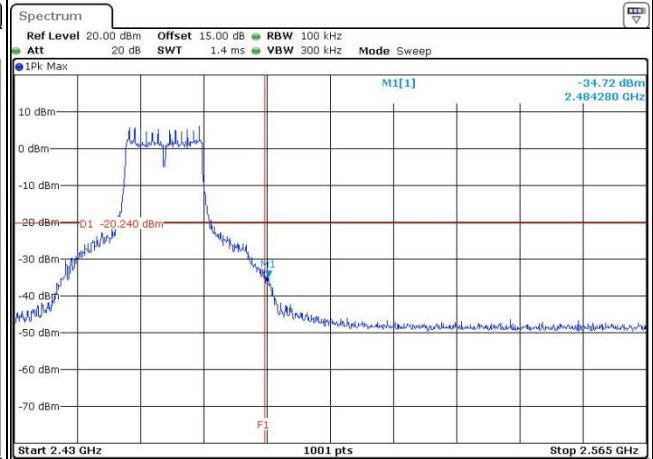

Spurious Emission 30MHz~2.4GHz

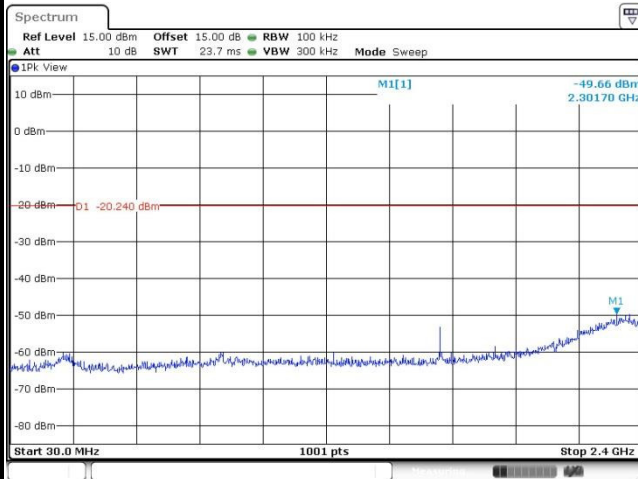

Spurious Emission 2.4835GHz~25GHz

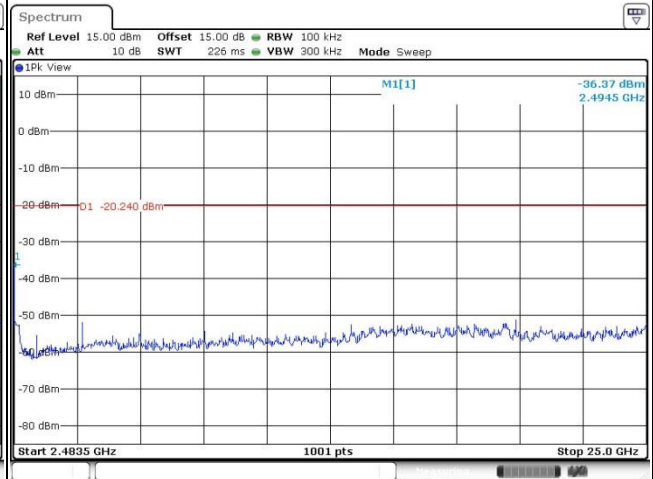



Number of TX :	2	Chain Port :	1
Test Mode :	802.11n HT20	Temperature :	24~26°C
Test Band :	2.4GHz Low	Relative Humidity :	50~53%
Test Channel :	01	Test Engineer :	Sam Zheng

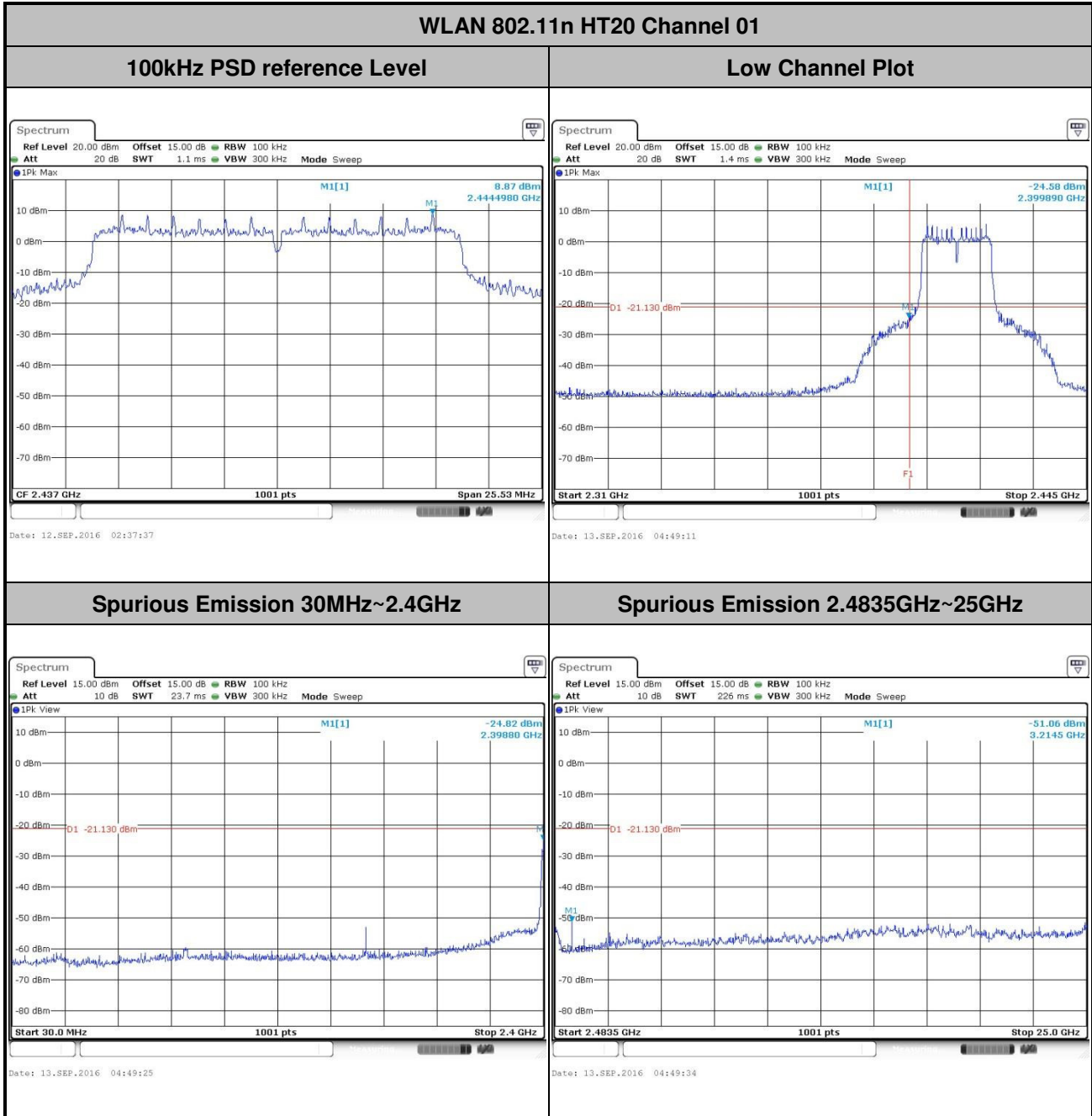



Number of TX :	2	Chain Port :	1
Test Mode :	802.11n HT20	Temperature :	24~26°C
Test Band :	2.4GHz Mid	Relative Humidity :	50~53%
Test Channel :	06	Test Engineer :	Sam Zheng

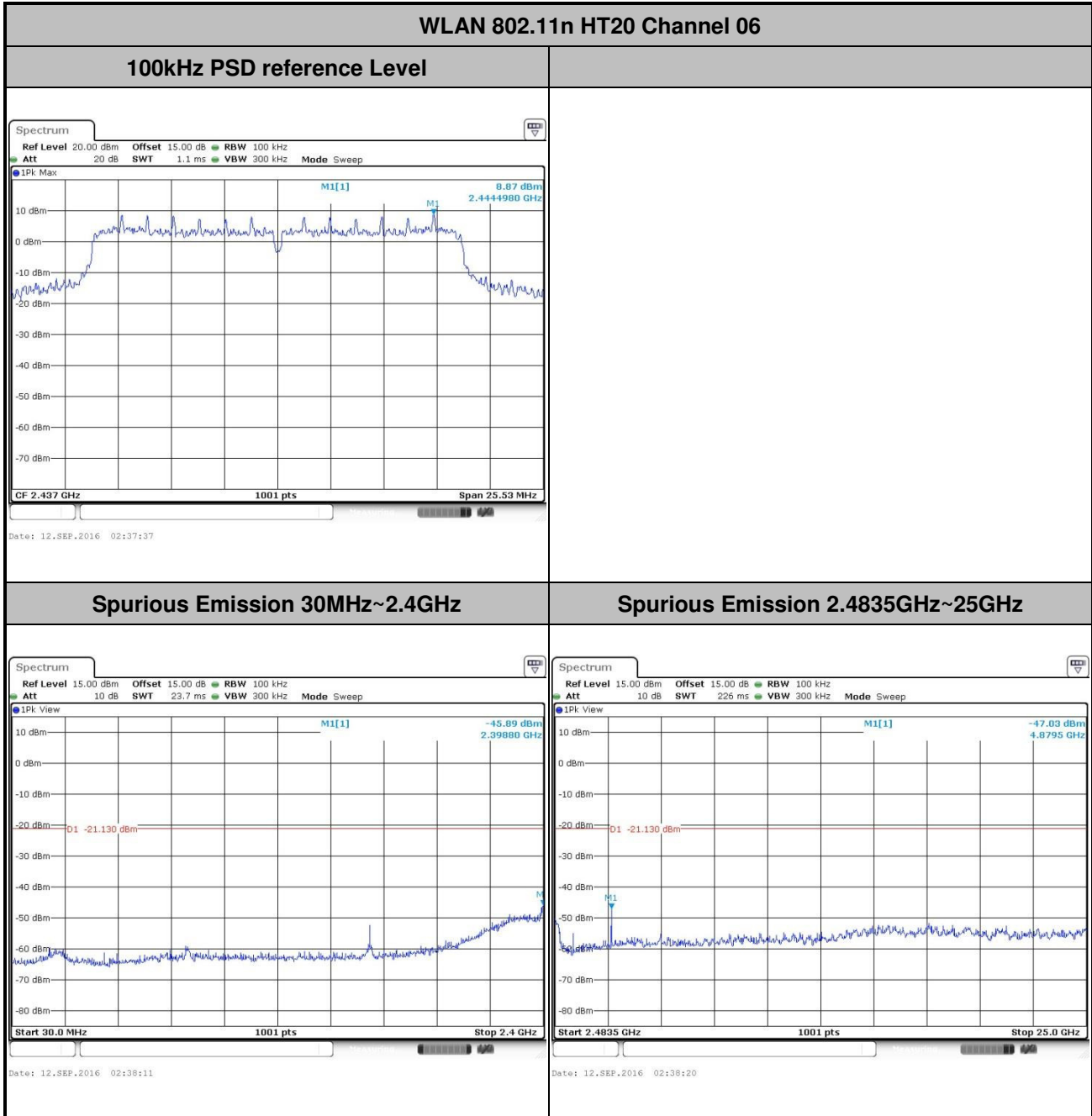



Number of TX :	2	Chain Port :	1
Test Mode :	802.11n HT20	Temperature :	24~26°C
Test Band :	2.4GHz High	Relative Humidity :	50~53%
Test Channel :	11	Test Engineer :	Sam Zheng

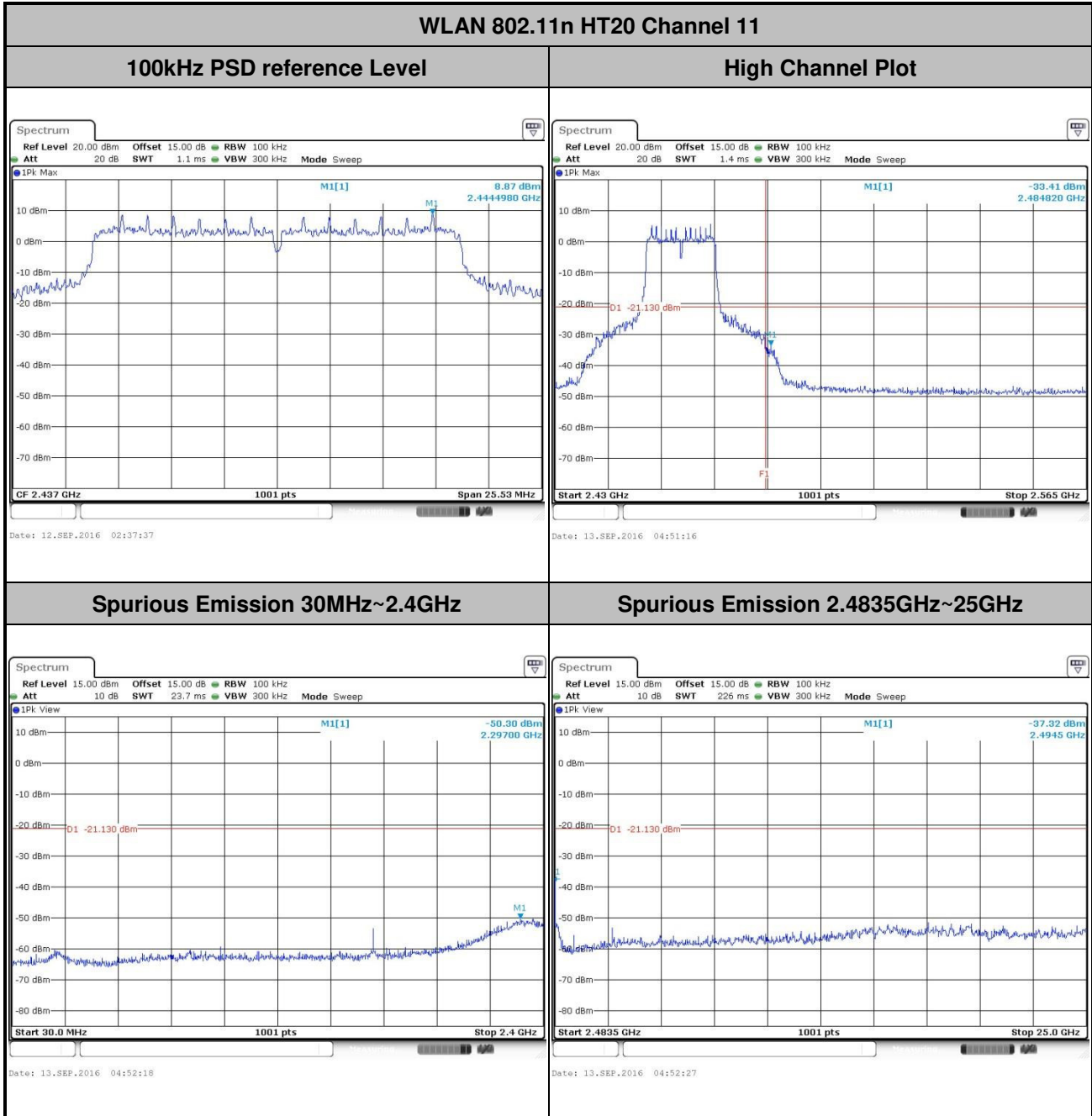



Number of TX :	2	Chain Port :	1
Test Mode :	802.11n HT40	Temperature :	24~26°C
Test Band :	2.4GHz Low	Relative Humidity :	50~53%
Test Channel :	03	Test Engineer :	Sam Zheng

WLAN 802.11n HT40 Channel 03

100kHz PSD reference Level

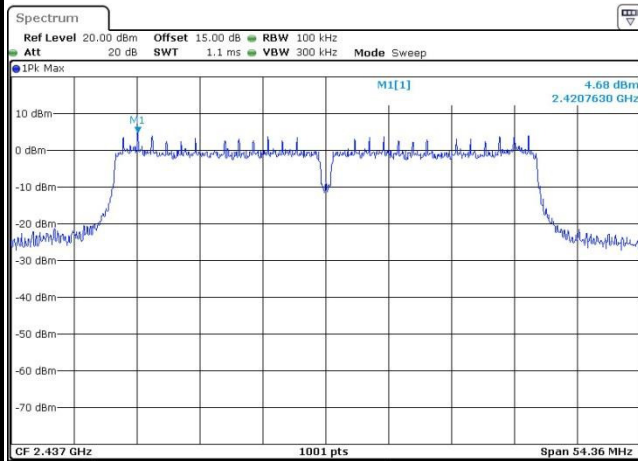

Date: 13.SEP.2016 03:55:17

Low Channel Plot

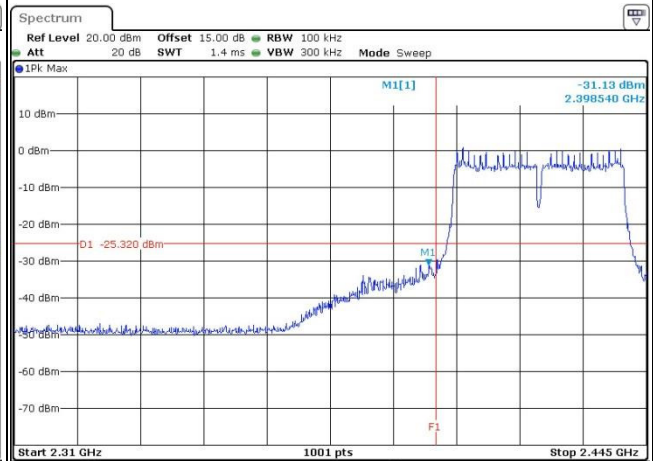

Date: 13.SEP.2016 04:41:04

Spurious Emission 30MHz~2.4GHz

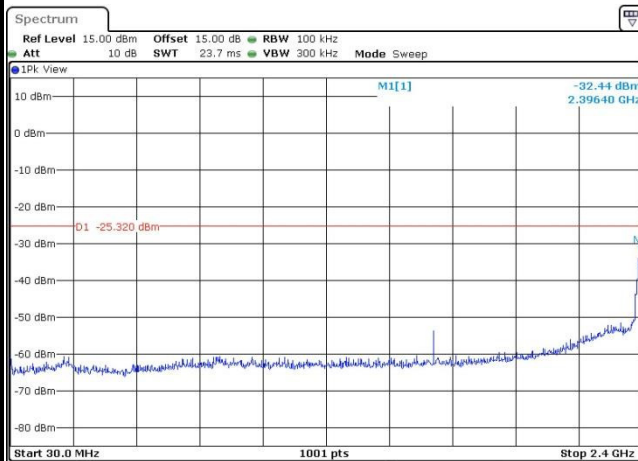

Date: 13.SEP.2016 07:02:45

Spurious Emission 2.4835GHz~25GHz

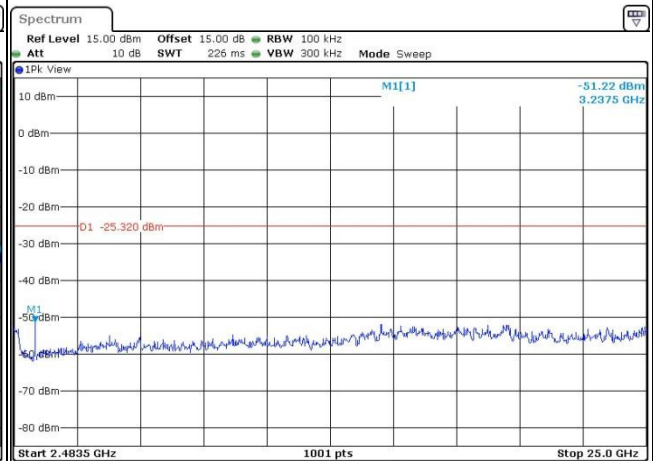

Date: 13.SEP.2016 07:02:54



Number of TX :	2	Chain Port :	1
Test Mode :	802.11n HT40	Temperature :	24~26°C
Test Band :	2.4GHz Mid	Relative Humidity :	50~53%
Test Channel :	06	Test Engineer :	Sam Zheng

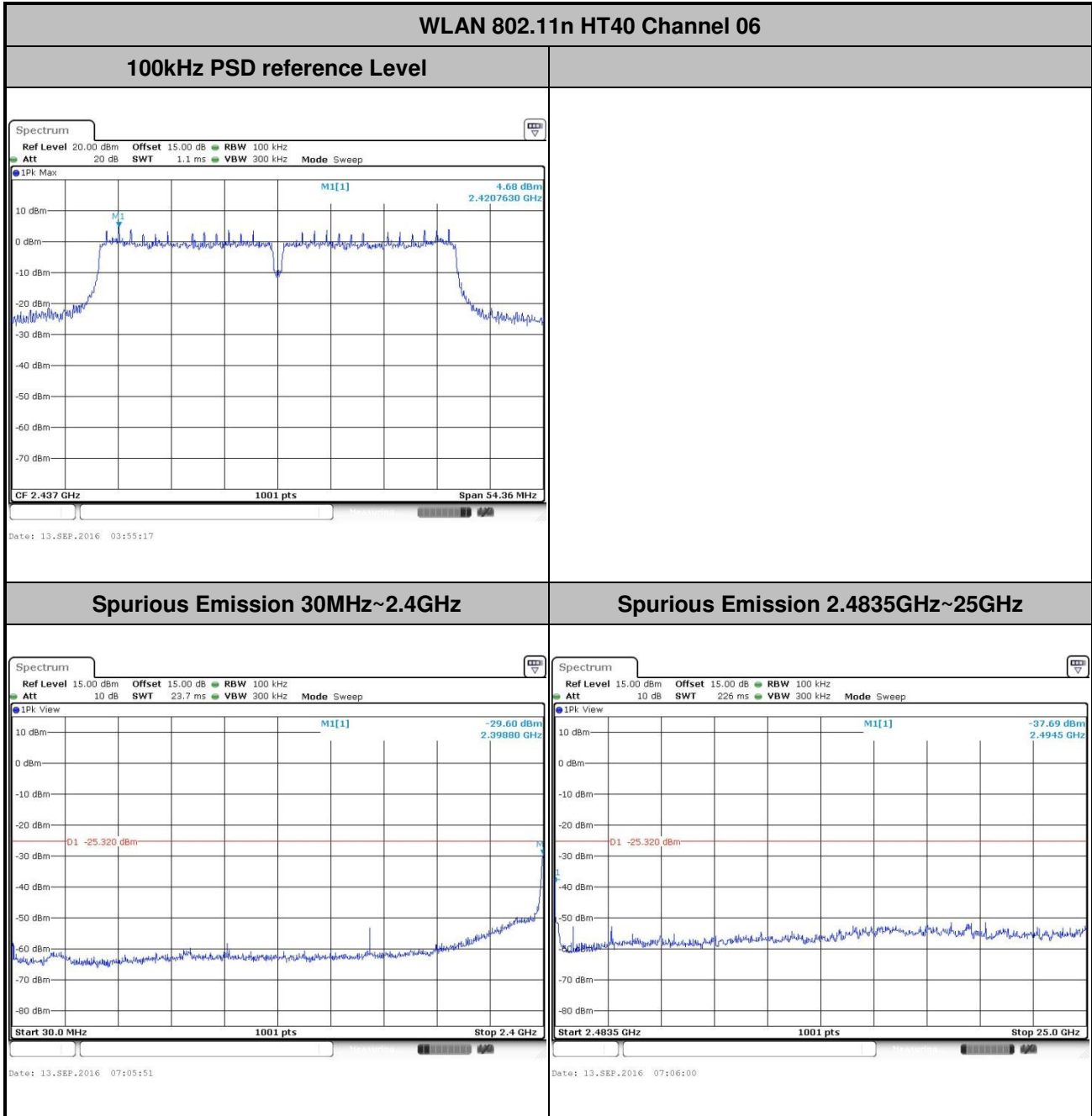



Number of TX :	2	Chain Port :	1
Test Mode :	802.11n HT40	Temperature :	24~26°C
Test Band :	2.4GHz High	Relative Humidity :	50~53%
Test Channel :	09	Test Engineer :	Sam Zheng

WLAN 802.11n HT40 Channel 09

100kHz PSD reference Level

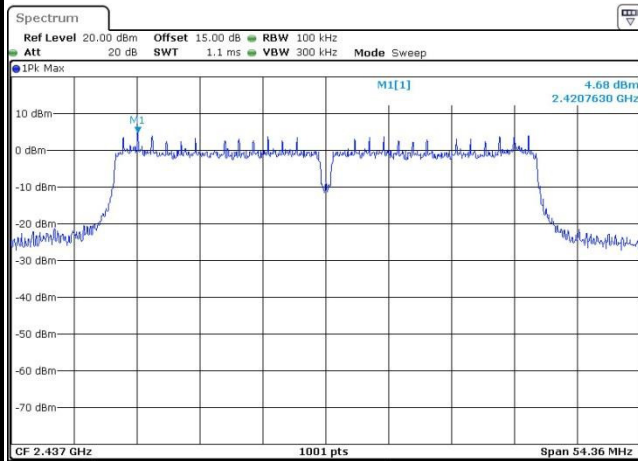

Date: 13.SEP.2016 03:55:17

High Channel Plot

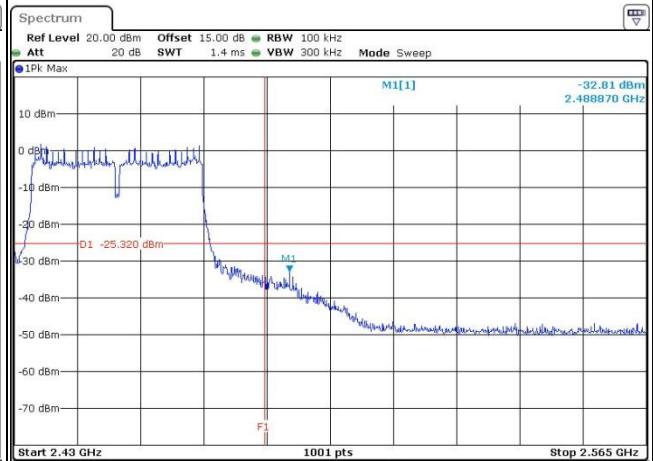

Date: 13.SEP.2016 04:26:29

Spurious Emission 30MHz~2.4GHz

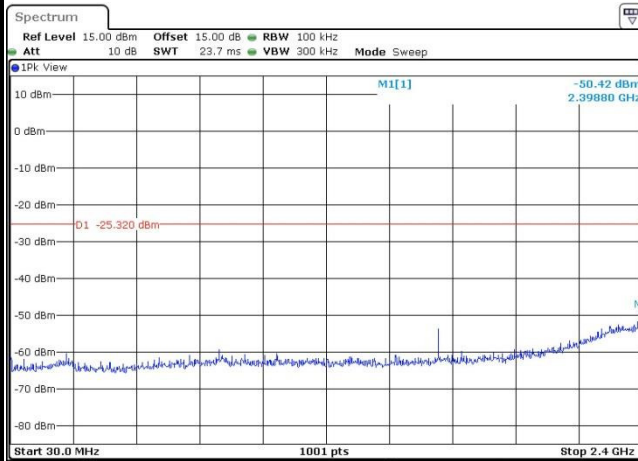

Date: 13.SEP.2016 04:34:36

Spurious Emission 2.4835GHz~25GHz

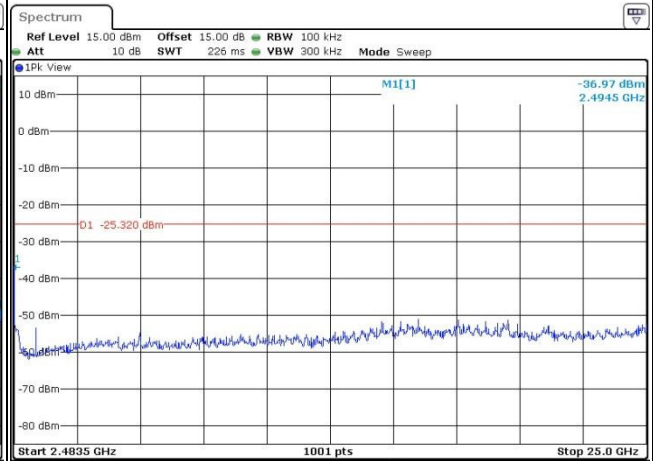

Date: 13.SEP.2016 04:34:45



Number of TX = 2, Chain Port 2 (Measured)

Number of TX :	2	Chain Port :	2
Test Mode :	802.11b	Temperature :	24~26°C
Test Band :	2.4GHz Low	Relative Humidity :	50~53%
Test Channel :	01	Test Engineer :	Sam Zheng

WLAN 802.11b Channel 01

100kHz PSD reference Level

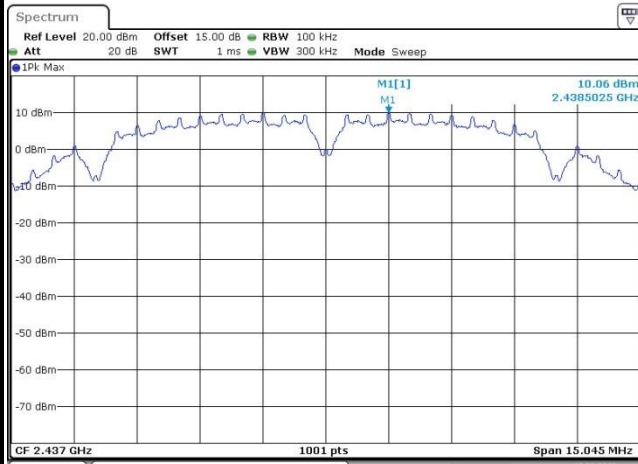

Date: 18.SEP.2016 10:48:20

Low Channel Plot

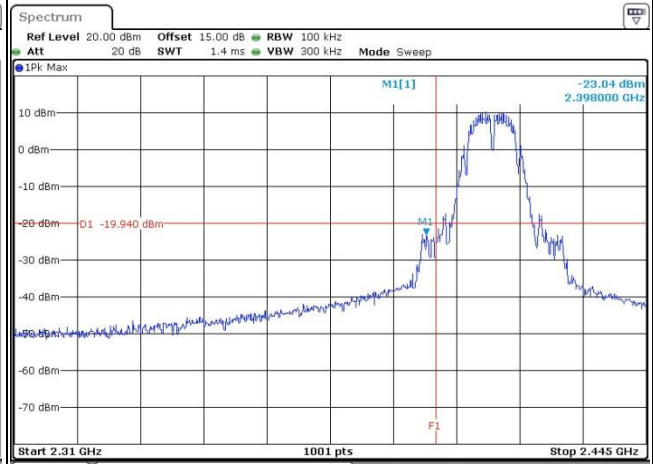

Date: 18.SEP.2016 11:07:19

Spurious Emission 30MHz~2.4GHz

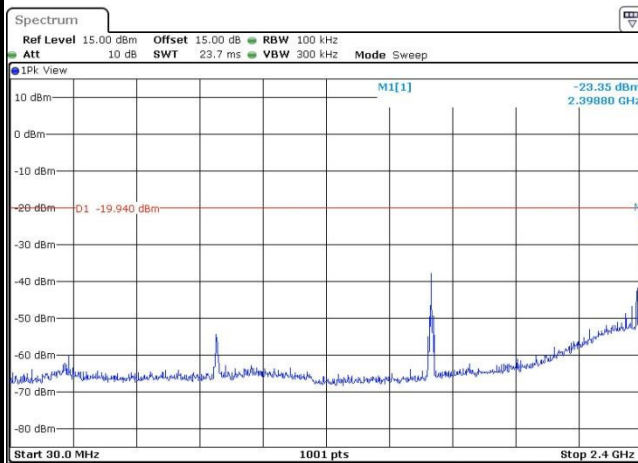

Date: 18.SEP.2016 11:08:19

Spurious Emission 2.4835GHz~25GHz

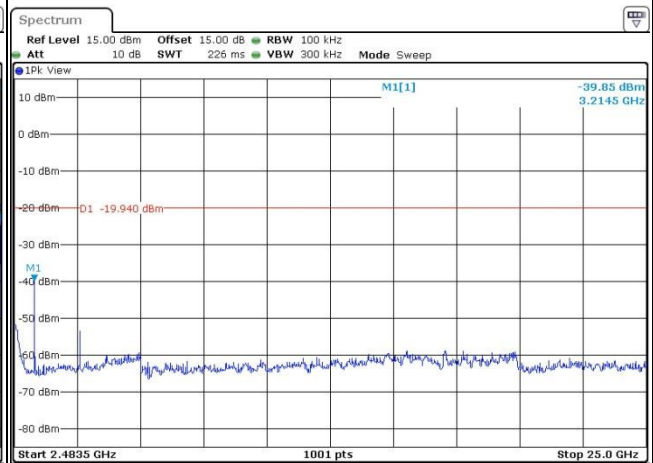

Date: 18.SEP.2016 11:08:27



Number of TX :	2	Chain Port :	2
Test Mode :	802.11b	Temperature :	24~26°C
Test Band :	2.4GHz Mid	Relative Humidity :	50~53%
Test Channel :	06	Test Engineer :	Sam Zheng

WLAN 802.11b Channel 06

100kHz PSD reference Level

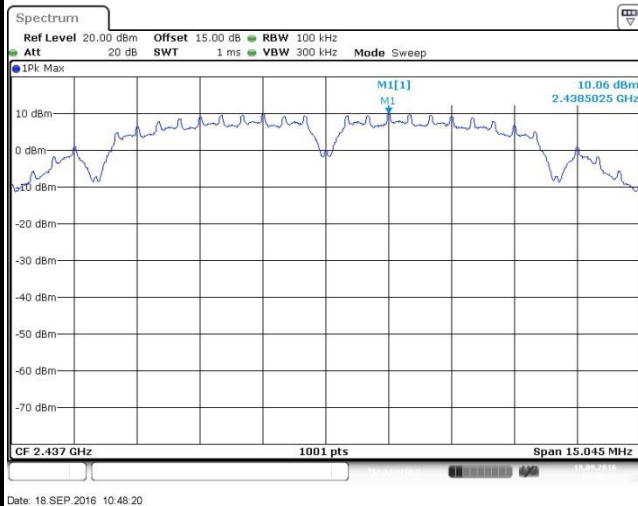

Spurious Emission 30MHz~2.4GHz

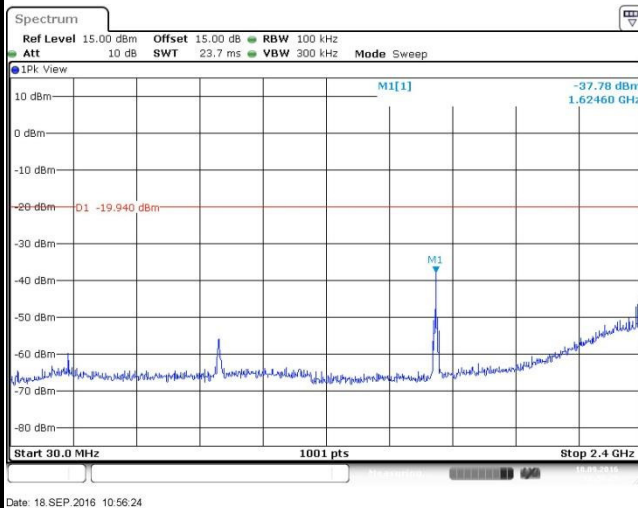

Spurious Emission 2.4835GHz~25GHz

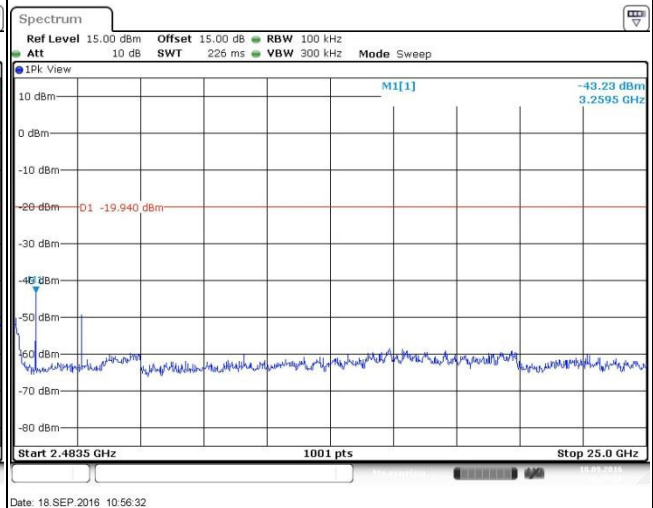



Number of TX :	2	Chain Port :	2
Test Mode :	802.11b	Temperature :	24~26°C
Test Band :	2.4GHz High	Relative Humidity :	50~53%
Test Channel :	11	Test Engineer :	Sam Zheng

WLAN 802.11b Channel 11

100kHz PSD reference Level

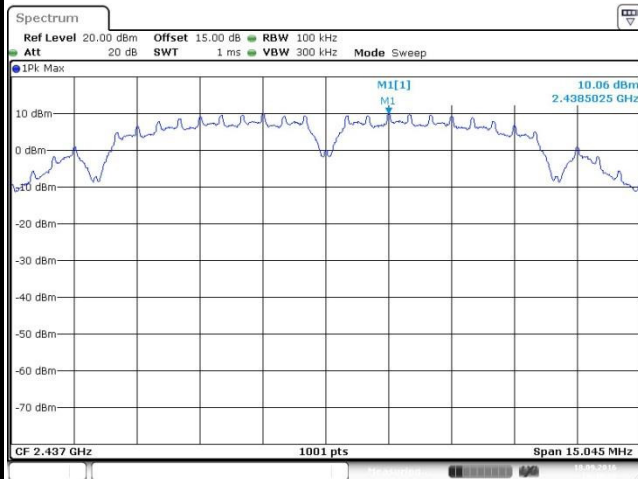

Date: 18.SEP.2016 10:48:20

High Channel Plot

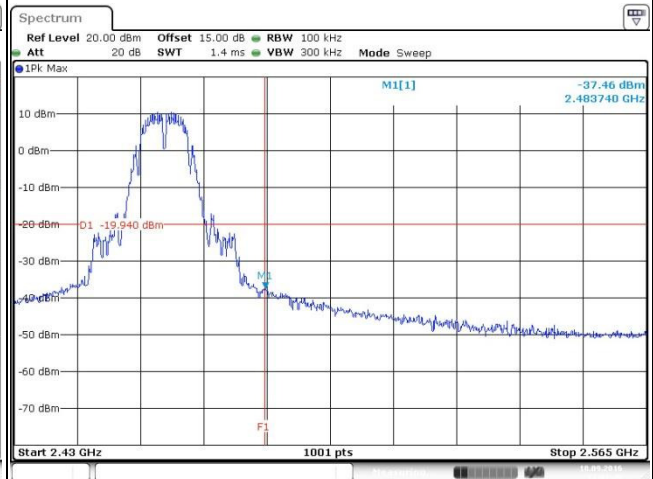

Date: 18.SEP.2016 11:01:42

Spurious Emission 30MHz~2.4GHz

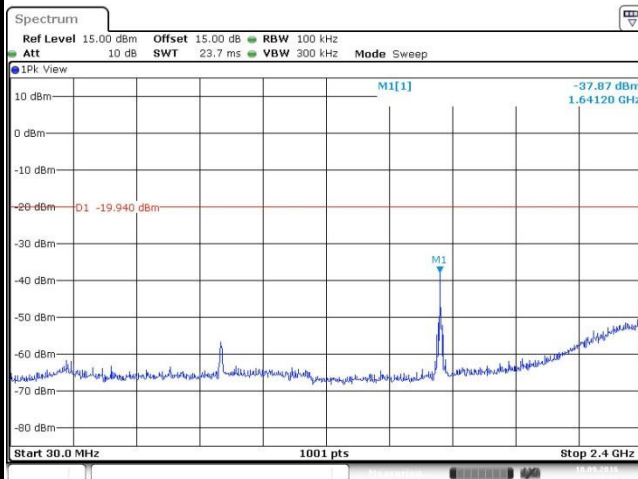

Date: 18.SEP.2016 11:01:58

Spurious Emission 2.4835GHz~25GHz

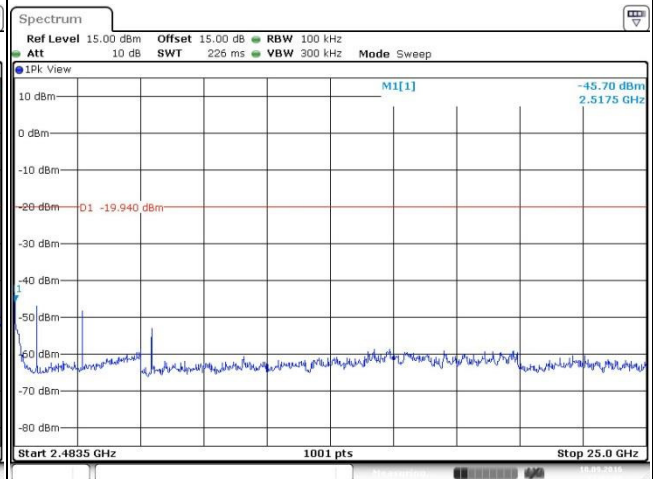

Date: 18.SEP.2016 11:02:06



Number of TX :	2	Chain Port :	2
Test Mode :	802.11g	Temperature :	24~26°C
Test Band :	2.4GHz Low	Relative Humidity :	50~53%
Test Channel :	01	Test Engineer :	Sam Zheng

WLAN 802.11g Channel 01

100kHz PSD reference Level

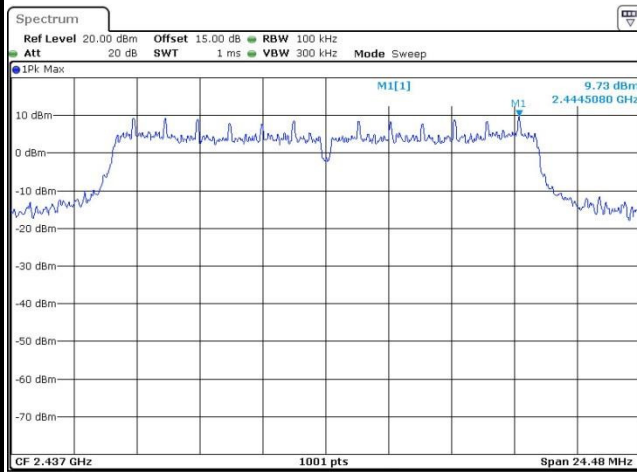

Date: 13.SEP.2016 08:05:50

Low Channel Plot

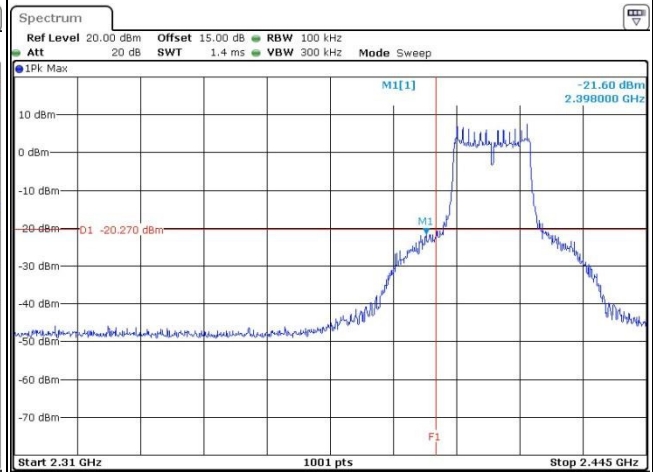

Date: 13.SEP.2016 08:20:24

Spurious Emission 30MHz~2.4GHz

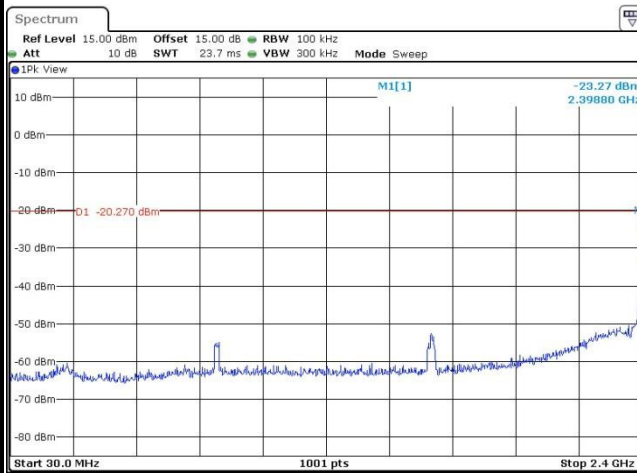

Date: 13.SEP.2016 08:21:17

Spurious Emission 2.4835GHz~25GHz

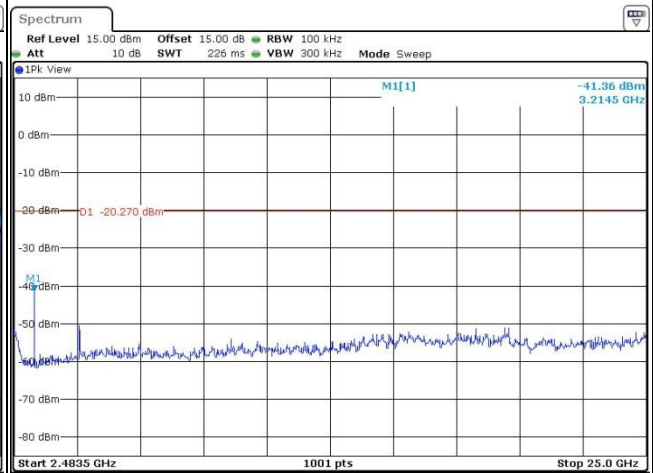

Date: 13.SEP.2016 08:21:25



Number of TX :	2	Chain Port :	2
Test Mode :	802.11g	Temperature :	24~26°C
Test Band :	2.4GHz Mid	Relative Humidity :	50~53%
Test Channel :	06	Test Engineer :	Sam Zheng

WLAN 802.11g Channel 06

100kHz PSD reference Level

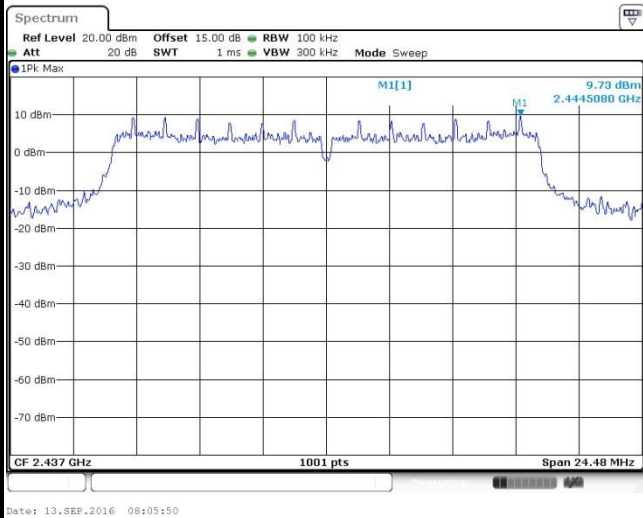

Spurious Emission 30MHz~2.4GHz

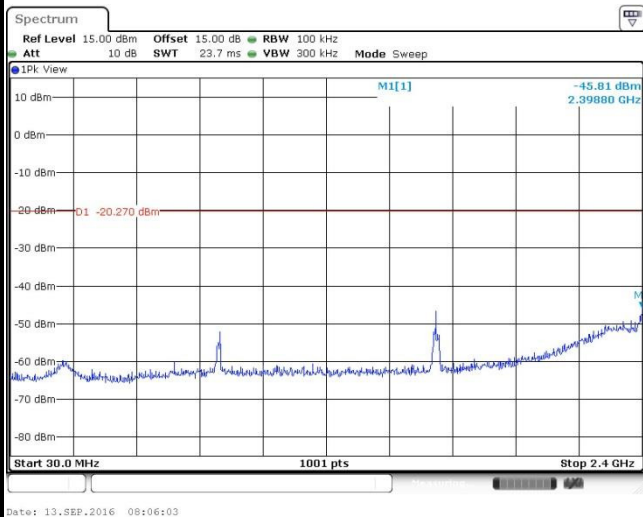

Spurious Emission 2.4835GHz~25GHz

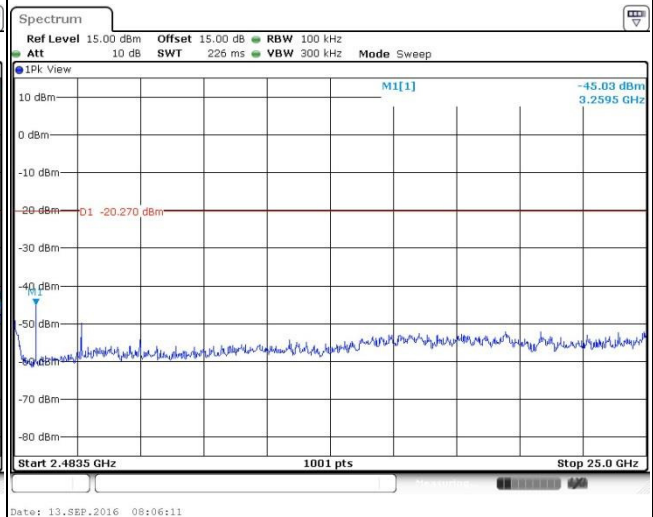



Number of TX :	2	Chain Port :	2
Test Mode :	802.11g	Temperature :	24~26°C
Test Band :	2.4GHz High	Relative Humidity :	50~53%
Test Channel :	11	Test Engineer :	Sam Zheng

WLAN 802.11g Channel 11

100kHz PSD reference Level

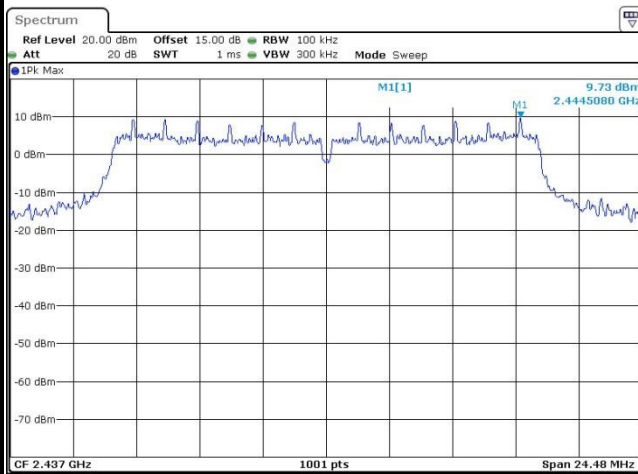

Date: 13.SEP.2016 08:05:50

High Channel Plot

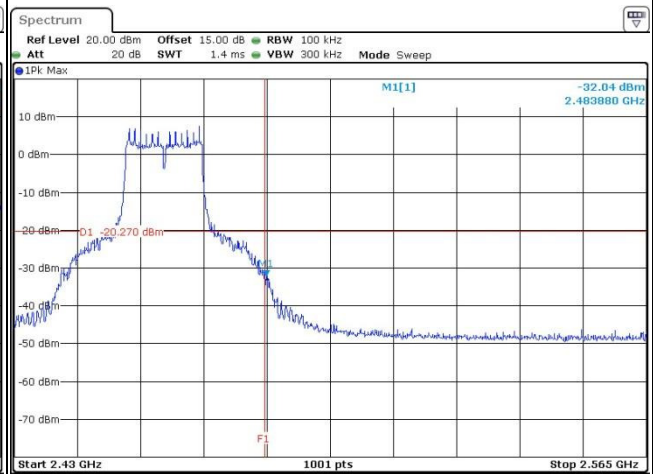

Date: 13.SEP.2016 08:11:31

Spurious Emission 30MHz~2.4GHz

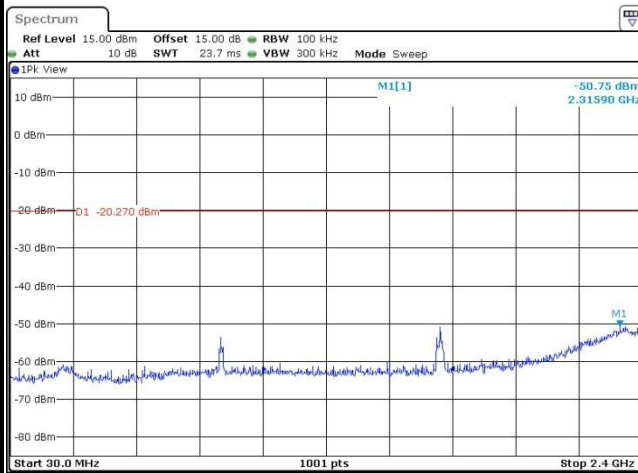

Date: 13.SEP.2016 08:14:49

Spurious Emission 2.4835GHz~25GHz

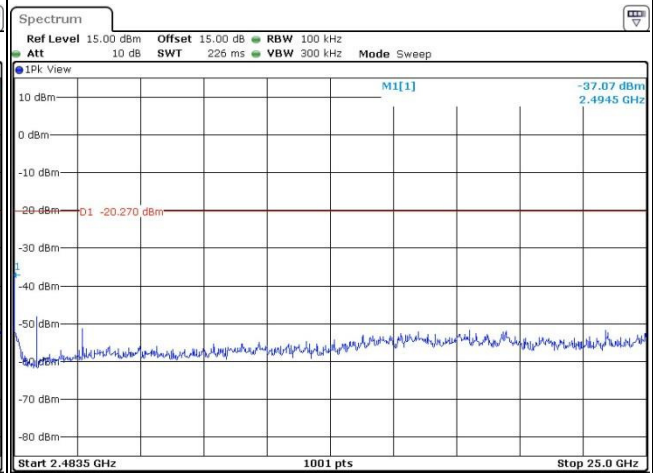

Date: 13.SEP.2016 08:14:58



Number of TX :	2	Chain Port :	2
Test Mode :	802.11n HT20	Temperature :	24~26°C
Test Band :	2.4GHz Low	Relative Humidity :	50~53%
Test Channel :	01	Test Engineer :	Sam Zheng

