



**CFR 47 FCC PART 15 SUBPART C
ISED RSS-247 ISSUE 2**

TEST REPORT

For

Kasa Smart Wi-Fi Light Switch, Single Pole

MODEL NUMBER: HS200

HVIN: HS200V5

FCC ID: TE7HS200V5

IC: 8853A-HS200V5

REPORT NUMBER: 4789574919-1

ISSUE DATE: August 11, 2020

Prepared for

**TP-Link Technologies Co., Ltd.
Building 24(floors1,3,4,5) and 28(floors1-4) Central Science and Technology Park,
Shennan Rd, Nanshan, Shenzhen, China**

Prepared by

**UL Verification Services (Guangzhou) Co., Ltd, Song Shan Lake Branch
Building 10, Innovation Technology Park, No. 1, Li Bin Road, Song Shan Lake
Hi-Tech Development Zone Dongguan, People's Republic of China
Tel: +86 769 22038881
Fax: +86 769 33244054
Website: www.ul.com**



Revision History

<u>Rev.</u>	<u>Issue Date</u>	<u>Revisions</u>	<u>Revised By</u>
V0	08/11/2020	Initial Issue	



Summary of Test Results			
Clause	Test Items	FCC/ISED Rules	Test Results
1	6dB Bandwidth and 99% Occupied Bandwidth	FCC Part 15.247 (a) (2) RSS-247 Clause 5.2 (a) ISED RSS-Gen Clause 6.7	Pass
2	Peak Conducted Output Power	FCC Part 15.247 (b) (3) RSS-247 Clause 5.4 (d)	Pass
3	Power Spectral Density	FCC Part 15.247 (e) RSS-247 Clause 5.2 (b)	Pass
4	Conducted Bandedge and Spurious Emission	FCC Part 15.247 (d) RSS-247 Clause 5.5	Pass
5	Radiated Bandedge and Spurious Emission	FCC Part 15.247 (d) FCC Part 15.209 FCC Part 15.205 RSS-247 Clause 5.5 RSS-GEN Clause 8.9	Pass
6	Conducted Emission Test For AC Power Port	FCC Part 15.207 RSS-GEN Clause 8.8	Pass
7	Antenna Requirement	FCC Part 15.203 RSS-GEN Clause 6.8	Pass

Note:
1. This test report is only published to and used by the applicant, and it is not for evidence purpose in China.
2. The measurement result for the sample received is <Pass> according to < CFR 47 FCC PART 15 SUBPART C >> ISED RSS-247 > when <Accuracy Method> decision rule is applied.



TABLE OF CONTENTS

1. ATTESTATION OF TEST RESULTS	6
2. TEST METHODOLOGY	8
3. FACILITIES AND ACCREDITATION	8
4. CALIBRATION AND UNCERTAINTY	9
4.1. <i>MEASURING INSTRUMENT CALIBRATION</i>	9
4.2. <i>MEASUREMENT UNCERTAINTY</i>	9
5. EQUIPMENT UNDER TEST	10
5.1. <i>DESCRIPTION OF EUT</i>	10
5.2. <i>MAXIMUM OUTPUT POWER</i>	10
5.3. <i>CHANNEL LIST</i>	10
5.4. <i>TEST CHANNEL CONFIGURATION</i>	10
5.5. <i>THE WORSE CASE POWER SETTING PARAMETER</i>	11
5.6. <i>THE WORSE CASE CONFIGURATIONS</i>	11
5.7. <i>DESCRIPTION OF AVAILABLE ANTENNAS</i>	11
5.8. <i>DESCRIPTION OF TEST SETUP</i>	12
6. MEASURING INSTRUMENT AND SOFTWARE USED	13
7. ANTENNA PORT TEST RESULTS	15
7.1. <i>ON TIME AND DUTY CYCLE</i>	15
7.2. <i>6 dB DTS BANDWIDTH AND 99% OCCUPIED BANDWIDTH</i>	16
7.3. <i>CONDUCTED OUTPUT POWER</i>	18
7.4. <i>POWER SPECTRAL DENSITY</i>	19
7.5. <i>CONDUCTED BANDEDGE AND SPURIOUS EMISSIONS</i>	20
8. RADIATED TEST RESULTS	22
8.1. <i>RESTRICTED BANDEDGE</i>	28
8.1.1. 802.11b MODE.....	28
8.1.2. 802.11g MODE.....	36
8.1.3. 802.11n HT20 MODE	52
8.2. <i>SPURIOUS EMISSIONS (3~18GHz)</i>	68
8.2.1. 802.11b MODE.....	68
8.2.2. 802.11g MODE.....	78
8.2.3. 802.11n HT20 MODE	88
8.3. <i>SPURIOUS EMISSIONS (1~3GHz)</i>	98
8.3.1. 802.11b MODE.....	98
8.3.2. 802.11g MODE.....	108



8.3.3.	802.11n HT20 MODE	118
8.4.	<i>SPURIOUS EMISSIONS (18~26GHz)</i>	128
8.4.1.	802.11g MODE.....	128
8.5.	<i>SPURIOUS EMISSIONS (0.03 ~ 1 GHz)</i>	130
8.5.1.	802.11g MODE.....	130
8.6.	<i>SPURIOUS EMISSIONS BELOW 30M</i>	132
8.6.1.	802.11g MODE.....	132
9.	AC POWER LINE CONDUCTED EMISSIONS	135
9.1.	802.11b MODE.....	136
10.	ANTENNA REQUIREMENTS.....	138
11.	11.Appendix.....	139
11.1.	<i>Appendix A: DTS Bandwidth</i>	139
11.1.1.	Test Result.....	139
11.1.2.	Test Graphs	140
11.2.	<i>Appendix B: Occupied Channel Bandwidth</i>	148
11.2.1.	Test Result.....	148
11.2.2.	Test Graphs	149
11.3.	<i>Appendix C: Maximum AVG conducted output power</i>	157
11.3.1.	Test Result.....	157
11.4.	<i>Appendix D: Maximum power spectral density</i>	158
11.4.1.	Test Result.....	158
11.4.2.	Test Graphs	159
11.5.	<i>Appendix E: Band edge measurements</i>	167
11.5.1.	Test Result.....	167
11.5.2.	Test Graphs	168
11.6.	<i>Appendix F: Conducted Spurious Emission</i>	174
11.6.1.	Test Result.....	174
11.6.2.	Test Graphs	175
11.7.	<i>Appendix G: Duty Cycle</i>	198
11.7.1.	Test Result.....	198
11.7.2.	Test Graphs	199



1. ATTESTATION OF TEST RESULTS

Applicant Information

Company Name: TP-Link Technologies Co., Ltd.
Address: Building 24(floors1,3,4,5) and 28(floors1-4) Central Science and Technology Park, Shennan Rd, Nanshan, Shenzhen, China

Manufacturer Information

Company Name: TP-Link Technologies Co., Ltd.
Address: Building 24(floors1,3,4,5) and 28(floors1-4) Central Science and Technology Park, Shennan Rd, Nanshan, Shenzhen, China

EUT Information

EUT Name: Kasa Smart Wi-Fi Light Switch, Single Pole
Model: HS200
HVIN: HS200V5
Brand Name: tp-link
Sample Status: Normal
Sample ID: 3222302
Sample Received Date: July 29, 2020
Date of Tested: July 30~August 6, 2020

APPLICABLE STANDARDS	
STANDARD	TEST RESULTS
CFR 47 FCC PART 15 SUBPART C	PASS
ISED RSS-247 Issue 2	PASS
ISED RSS-GEN Issue 5	PASS

Prepared By:

Kebo Zhang
Project Engineer

Checked By:

Shawn Wen
Laboratory Leader

Approved By:

Stephen Guo



Laboratory Manager



2. TEST METHODOLOGY

The tests documented in this report were performed in accordance with KDB 558074 D01 15.247 Meas Guidance v05r02, 414788 D01 Radiated Test Site v01r01, KDB 662911 D01 Multiple Transmitter Output v02r01, CFR 47 FCC Part 2, CFR 47 FCC Part 15, ANSI C63.10-2013, ISED RSS-247 Issue 2 and ISED RSS-GEN Issue 5.

3. FACILITIES AND ACCREDITATION

Accreditation Certificate	<p>A2LA (Certificate No.: 4102.01) UL Verification Services (Guangzhou) Co., Ltd. Song Shan Lake Branch. has been assessed and proved to be in compliance with A2LA.</p> <p>FCC (FCC Designation No.: CN1187) UL Verification Services (Guangzhou) Co., Ltd. Song Shan Lake Branch. Has been recognized to perform compliance testing on equipment subject to the Commission's Declaration of Conformity (DoC) and Certification rules</p> <p>ISED(Company No.: 21320) UL Verification Services (Guangzhou) Co., Ltd. Song Shan Lake Branch. has been registered and fully described in a report filed with ISED. The Company Number is 21320.</p> <p>VCCI (Registration No.: G-20019, R-20004, C-20012 and T-20011) UL Verification Services (Guangzhou) Co., Ltd. Song Shan Lake Branch. has been assessed and proved to be in compliance with VCCI, the Membership No. is 3793. Facility Name: Chamber D, the VCCI registration No. is G-20019 and R-20004 Shielding Room B , the VCCI registration No. is C-20012 and T-20011</p>
---------------------------	---

Note 1: All tests measurement facilities use to collect the measurement data are located at Building 10, Innovation Technology Park, Song Shan Lake Hi tech Development Zone, Dongguan, 523808, China

Note 2: The test anechoic chamber in UL Verification Services (Guangzhou) Co., Ltd. Song Shan Lake Branch had been calibrated and compared to the open field sites and the test anechoic chamber is shown to be equivalent to or worst case from the open field site.

Note 3: For below 30MHz, lab had performed measurements at test anechoic chamber and comparing to measurements obtained on an open field site. And these measurements below 30MHz had been correlated to measurements performed on an OFS.



4. CALIBRATION AND UNCERTAINTY

4.1. MEASURING INSTRUMENT CALIBRATION

The measuring equipment utilized to perform the tests documented in this report has been calibrated in accordance with the manufacturer's recommendations, and is traceable to recognize national standards.

4.2. MEASUREMENT UNCERTAINTY

Where relevant, the following measurement uncertainty levels have been estimated for tests performed on the apparatus:

Test Item	Uncertainty
AC Power Port Conduction emission	3.62 dB
Radiated Emission (Included Fundamental Emission) (9 kHz ~ 30 MHz)	2.2 dB
Radiated Emission (Included Fundamental Emission) (30 MHz ~ 1 GHz)	4.00 dB
Radiated Emission (Included Fundamental Emission) (1 GHz to 26 GHz)	5.78 dB (1 GHz ~ 18 GHz)
	5.23 dB (18 GHz ~ 26 GHz)
DTS Bandwidth and 99% Occupied Bandwidth	± 0.0196 %
Conducted Output Power	± 0.686 dB
Conducted Power Spectral Density	± 0.743 dB
Conducted Band Edge Measurements	± 1.328 dB
Conducted Spurious Emissions	± 0.746 dB (9 kHz ~ 1 GHz)
	± 1.328 dB (1 GHz ~ 26 GHz)

Note: This uncertainty represents an expanded uncertainty expressed at approximately the 95% confidence level using a coverage factor of k=2.



5. EQUIPMENT UNDER TEST

5.1. DESCRIPTION OF EUT

Equipment	Kasa Smart Wi-Fi Light Switch, Single Pole
Model Name	HS200
Radio Technology	IEEE802.11b/g/n HT20
Operation frequency	IEEE 802.11b: 2412MHz ~ 2462MHz IEEE 802.11g: 2412MHz ~ 2462MHz IEEE 802.11n HT20: 2412MHz ~ 2462MHz
Modulation	IEEE 802.11b: DSSS (CCK, DQPSK, DBPSK) IEEE 802.11g: OFDM (64QAM, 16QAM, QPSK, BPSK) IEEE 802.11n HT20: OFDM (64QAM, 16QAM, QPSK, BPSK)
Software version	HS200_FCC_1.0.0_Build_200528_Rel.111008_flash.bin
Firmware version	1.0
Rated Input	AC120V,60Hz

5.2. MAXIMUM OUTPUT POWER

Number of Transmit Chains (NTX)	IEE Std. 802.11	Frequency (MHz)	Channel Number	Max AV Conducted Power (dBm)
1	IEEE 802.11b	2412-2462	1-11[11]	19.19
1	IEEE 802.11g	2412-2462	1-11[11]	19.20
1	IEEE 802.11nHT20	2412-2462	1-11[11]	18.19

5.3. CHANNEL LIST

Channel List for IEEE 802.11b/g/n (20 MHz)							
Channel	Frequency (MHz)	Channel	Frequency (MHz)	Channel	Frequency (MHz)	Channel	Frequency (MHz)
1	2412	4	2427	7	2442	10	2457
2	2417	5	2432	8	2447	11	2462
3	2422	6	2437	9	2452	/	/

5.4. TEST CHANNEL CONFIGURATION

Test Mode	Test Channel	Frequency (MHz)
802.11b	CH 1, CH2, CH 6, CH10, CH 11	2412, 2417, 2437, 2457, 2462
802.11g	CH 1, CH2, CH 6, CH10, CH 11	2412, 2417, 2437, 2457, 2462
802.11n HT20	CH 1, CH2, CH 6, CH10, CH 11	2412, 2417, 2437, 2457, 2462



5.5. THE WORSE CASE POWER SETTING PARAMETER

The Worst Case Power Setting Parameter under 2400 ~ 2483.5MHz Band											
Test Software		QATool_Dbg									
Modulation Mode	Transmit Antenna Number	Test Software Setting Value									
		NCB: 20MHz					NCB: 40MHz				
		CH1	CH2	CH6	CH10	CH11	CH3	CH4	CH7	CH8	CH11
802.11b	1	93	93	92	92	92	NA				
802.11g	1	107	107	106	106	106					
802.11n HT20	1	103	103	102	102	102					

5.6. THE WORSE CASE CONFIGURATIONS

Worst-case data rates as provided by the client were:

- 802.11b mode: 1 Mbps
- 802.11b mode: 6 Mbps
- 802.11n HT20 mode: MCS0

5.7. DESCRIPTION OF AVAILABLE ANTENNAS

Antenna	Frequency (MHz)	Antenna Type	MAX Antenna Gain (dBi)
1	2412-2462	PCB Antenna	2.5

Test Mode	Transmit and Receive Mode	Description
IEEE 802.11b	<input checked="" type="checkbox"/> 1TX, 1RX	Antenna 1 can be used as transmitting/receiving antenna.
IEEE 802.11g	<input checked="" type="checkbox"/> 1TX, 1RX	Antenna 1 can be used as transmitting/receiving antenna.
IEEE 802.11n HT20	<input checked="" type="checkbox"/> 1TX, 1RX	Antenna 1 can be used as transmitting/receiving antenna.

Note: The value of the antenna gain was declared by customer.

5.8. DESCRIPTION OF TEST SETUP

SUPPORT EQUIPMENT

Item	Equipment	Brand Name	Model Name	Remarks
1	Laptop	ThinkPad	X230i	/
2	USB TO UART	/	/	/

I/O CABLES

Item	Port	Connector Type	Cable Type	Cable Length(m)	Remarks
1	USB	NA	NA	1	/

ACCESSORIES

Item	Accessory	Brand Name	Model Name	Description
1	/	/	/	/

TEST SETUP

The EUT can work in engineering mode with a software through a Laptop.

SETUP DIAGRAM FOR TESTS

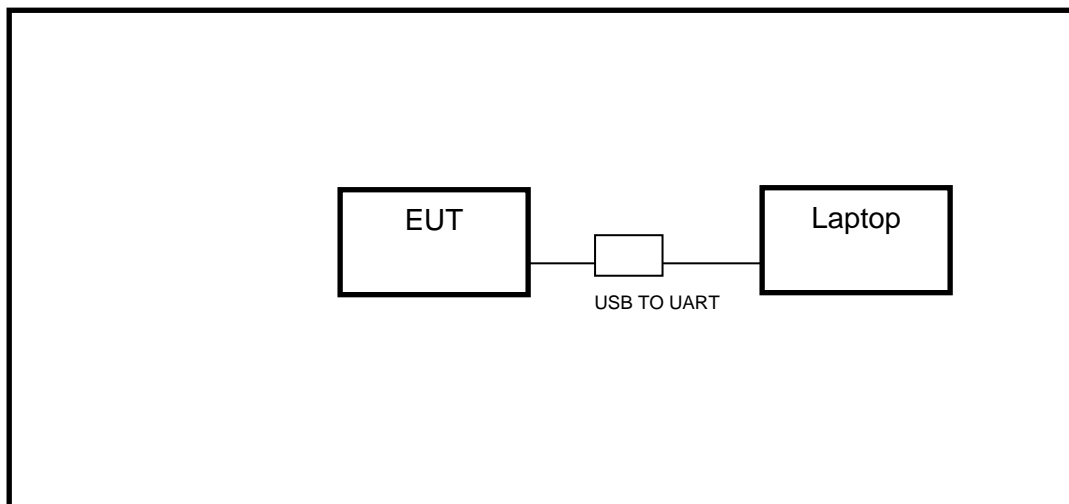



6. MEASURING INSTRUMENT AND SOFTWARE USED

AC Power Line Conducted Emissions (Shielding Room B)						
Instrument						
Used	Equipment	Manufacturer	Model No.	Serial No.	Last Cal.	Next Cal.
<input checked="" type="checkbox"/>	EMI Test Receiver	R&S	ESR3	101961	Dec.05,2019	Dec.05,2020
<input checked="" type="checkbox"/>	Two-Line V- Network	R&S	ENV216	101983	Dec.05,2019	Dec.05,2020
<input checked="" type="checkbox"/>	Artificial Mains Networks	Schwarzbeck	NSLK 8126	8126465	Dec.05,2019	Dec.05,2020
Software						
Used	Description			Manufacturer	Name	Version
<input checked="" type="checkbox"/>	Test Software for Conducted disturbance			Farad	EZ-EMC	Ver. UL-3A1
Radiated Emissions (Chamber C)						
Instrument						
Used	Equipment	Manufacturer	Model No.	Serial No.	Last Cal.	Next Cal.
<input checked="" type="checkbox"/>	MXE EMI Receiver	KESIGHT	N9038A	MY56400036	Dec.06,2019	Dec.05,2020
<input checked="" type="checkbox"/>	Hybrid Log Periodic Antenna	TDK	HLP-3003C	130960	Sep.17,2018	Sep.17,2021
<input checked="" type="checkbox"/>	Preamplifier	HP	8447D	2944A09099	Dec.05,2019	Dec.05,2020
<input checked="" type="checkbox"/>	EMI Measurement Receiver	R&S	ESR26	101377	Dec.05,2019	Dec.05,2020
<input checked="" type="checkbox"/>	Horn Antenna	TDK	HRN-0118	130939	Sep.17,2018	Sep.17,2021
<input checked="" type="checkbox"/>	High Gain Horn Antenna	Schwarzbeck	BBHA-9170	691	Aug.11,2018	Aug.11,2021
<input checked="" type="checkbox"/>	Preamplifier	TDK	PA-02-0118	TRS-305- 00067	Dec.05,2019	Dec.05,2020
<input checked="" type="checkbox"/>	Preamplifier	TDK	PA-02-2	TRS-307- 00003	Dec.05,2019	Dec.05,2020
<input checked="" type="checkbox"/>	Loop antenna	Schwarzbeck	1519B	00008	Jan.07,2019	Jan.07,2022
<input checked="" type="checkbox"/>	Band Reject Filter	Wainwright	WRCJV8-2350-2400- 2483.5-2533.5-40SS	4	Dec.05,2019	Dec.05,2020
<input checked="" type="checkbox"/>	High Pass Filter	Wi	WHKX10-2700-3000- 18000-40SS	23	Dec.05,2019	Dec.05,2020
Software						
Used	Description			Manufacturer	Name	Version
<input checked="" type="checkbox"/>	Test Software for Radiated disturbance			Farad	EZ-EMC	Ver. UL-3A1



RF Conducted (Shielding Room D)						
Used	Equipment	Manufacturer	Model No.	Serial No.	Last Cal.	Next Cal.
<input checked="" type="checkbox"/>	Spectrum Analyzer	Keysight	N9030A	MY55410512	Dec.06,2019	Dec.05,2020
<input checked="" type="checkbox"/>	Power sensor, Power Meter	R&S	OSP120	100921	Dec.06,2019	Dec.06,2020
<input checked="" type="checkbox"/>	Attenuator	Agilent	8496B	US00431137	Dec.05,2019	Dec.05,2020



7. ANTENNA PORT TEST RESULTS

7.1. ON TIME AND DUTY CYCLE

LIMITS

None; for reporting purposes only

PROCEDURE

KDB 558074 Zero-Span Spectrum Analyzer Method

TEST SETUP

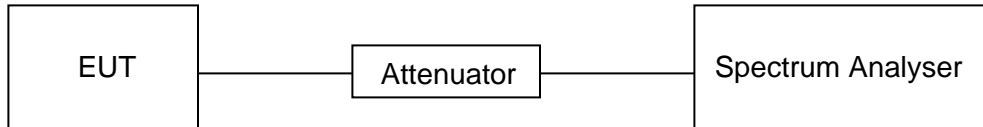

TEST ENVIRONMENT

Temperature	24.6°C	Relative Humidity	60.8%
Atmosphere Pressure	101kPa	Test Voltage	AC 120V, 60Hz

RESULTS

Please refer to appendix G.

7.2. 6 dB DTS BANDWIDTH AND 99% OCCUPIED BANDWIDTH

LIMITS

CFR 47 FCC Part15 (15.247) Subpart C ISED RSS-247 ISSUE 2			
Section	Test Item	Limit	Frequency Range (MHz)
CFR 47 FCC 15.247(a)(2) ISED RSS-247 5.2 (a)	6 dB Bandwidth	≥ 500KHz	2400-2483.5
ISED RSS-Gen Clause 6.7	99% Occupied Bandwidth	For reporting purposes only.	2400-2483.5

TEST PROCEDURE

Connect the UUT to the spectrum analyser and use the following settings:

Center Frequency	The centre frequency of the channel under test
Detector	Peak
RBW	For 6dB Bandwidth :100kHz For 99% Occupied Bandwidth :1% to 5% of the occupied bandwidth
VBW	For 6dB Bandwidth : ≥3 × RBW For 99% Occupied Bandwidth : ≥3×RBW
Trace	Max hold
Sweep	Auto couple

Allow the trace to stabilize and measure the maximum width of the emission that is constrained by the frequencies associated with the two outermost amplitude points (upper and lower frequencies) that are attenuated by 6 dB and 99% relative to the maximum level measured in the fundamental emission.

TEST SETUP

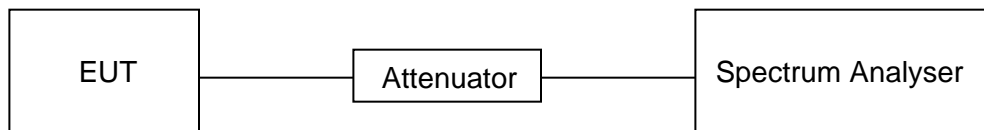



TEST ENVIRONMENT

Temperature	24.6°C	Relative Humidity	60.8%
Atmosphere Pressure	101kPa	Test Voltage	AC 120V, 60Hz

RESULTS

Please refer to appendix A and B.



7.3. CONDUCTED OUTPUT POWER

LIMITS

CFR 47 FCC Part15 (15.247) Subpart C ISED RSS-247 ISSUE 2			
Section	Test Item	Limit	Frequency Range (MHz)
CFR 47 FCC 15.247(b)(3) ISED RSS-247 5.4 (d)	Peak Output Power	1 watt or 30dBm	2400-2483.5

TEST PROCEDURE

Place the EUT on the table and set it in the transmitting mode.
Remove the antenna from the EUT and then connect a low loss RF cable from the antenna port to the Power sensor.
Measure peak power each channel.
Peak Detector use for Peak result.
AVG Detector use for AVG result.

TEST SETUP

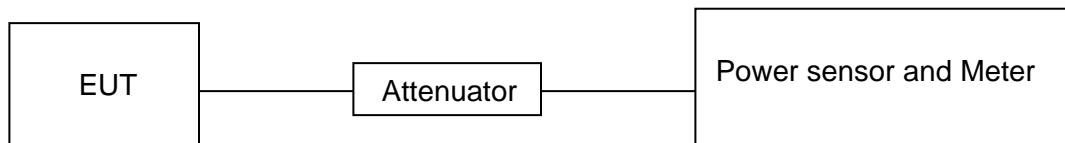

TEST ENVIRONMENT

Temperature	25.6°C	Relative Humidity	62.2%
Atmosphere Pressure	101kPa	Test Voltage	AC 120V, 60Hz

RESULTS

Please refer to appendix C.



7.4. POWER SPECTRAL DENSITY

LIMITS

CFR 47 FCC Part15 (15.247) Subpart C ISED RSS-247 ISSUE 2			
Section	Test Item	Limit	Frequency Range (MHz)
CFR 47 FCC §15.247 (e) ISED RSS-247 5.2 (b)	Power Spectral Density	8 dBm/3 kHz	2400-2483.5

TEST PROCEDURE

Connect the UUT to the spectrum analyser and use the following settings:

Center Frequency	The centre frequency of the channel under test
Detector	Peak
RBW	$3 \text{ kHz} \leq \text{RBW} \leq 100 \text{ kHz}$
VBW	$\geq 3 \times \text{RBW}$
Span	1.5 x DTS bandwidth
Trace	Max hold
Sweep time	Auto couple.

Allow trace to fully stabilize and use the peak marker function to determine the maximum amplitude level within the RBW.

If measured value exceeds limit, reduce RBW (no less than 3 kHz) and repeat.

TEST SETUP

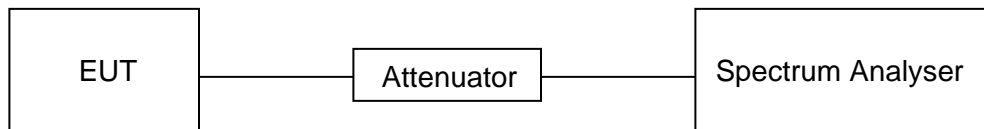

TEST ENVIRONMENT

Temperature	24.6°C	Relative Humidity	60.8%
Atmosphere Pressure	101kPa	Test Voltage	AC 120V, 60Hz

RESULTS

Please refer to appendix C.



7.5. CONDUCTED BANDEGE AND SPURIOUS EMISSIONS

LIMITS

CFR 47 FCC Part15 (15.247) Subpart C ISED RSS-247 ISSUE 2		
Section	Test Item	Limit
CFR 47 FCC §15.247 (d) ISED RSS-247 5.5	Conducted Bandedge and Spurious Emissions	at least 20 dB below that in the 100 kHz bandwidth within the band that contains the highest level of the desired power

TEST PROCEDURE

Connect the UUT to the spectrum analyser and use the following settings:

Center Frequency	The centre frequency of the channel under test
Detector	Peak
RBW	100kHz
VBW	$\geq 3 \times \text{RBW}$
Span	1.5 x DTS bandwidth
Trace	Max hold
Sweep time	Auto couple.

Use the peak marker function to determine the maximum PSD level.

Span	Set the center frequency and span to encompass frequency range to be measured
Detector	Peak
RBW	100kHz
VBW	$\geq 3 \times \text{RBW}$
measurement points	$\geq \text{span}/\text{RBW}$
Trace	Max hold
Sweep time	Auto couple.

Use the peak marker function to determine the maximum amplitude level.



TEST SETUP

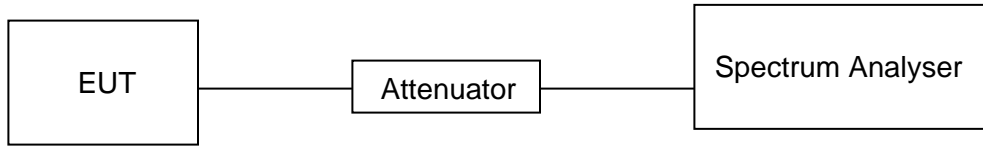

TEST ENVIRONMENT

Temperature	24.6°C	Relative Humidity	60.8%
Atmosphere Pressure	101kPa	Test Voltage	AC 120V, 60Hz

RESULTS

Please refer to appendix E and F.



8. RADIATED TEST RESULTS

LIMITS

Please refer to CFR 47 FCC §15.205 and §15.209

Please refer to ISED RSS-GEN Clause 8.9 (Transmitter)

Radiation Disturbance Test Limit for FCC (Class B)(9kHz-1GHz)

Emissions radiated outside of the specified frequency bands above 30MHz			
Frequency Range (MHz)	Field Strength Limit (uV/m) at 3 m	Field Strength Limit (dBuV/m) at 3 m	
		Quasi-Peak	
30 - 88	100	40	
88 - 216	150	43.5	
216 - 960	200	46	
Above 960	500	54	
Above 1000	500	Peak	Average
		74	54

FCC Emissions radiated outside of the specified frequency bands below 30MHz		
Frequency (MHz)	Field strength (microvolts/meter)	Measurement distance (meters)
0.009-0.490	2400/F(kHz)	300
0.490-1.705	24000/F(kHz)	30
1.705-30.0	30	30

ISED General field strength limits at frequencies below 30 MHz

Table 6 – General field strength limits at frequencies below 30 MHz		
Frequency	Magnetic field strength (H-Field) (µA/m)	Measurement distance (m)
9 - 490 kHz ^{Note 1}	6.37/F (F in kHz)	300
490 - 1705 kHz	63.7/F (F in kHz)	30
1.705 - 30 MHz	0.08	30

Note 1: The emission limits for the ranges 9-90 kHz and 110-490 kHz are based on measurements employing a linear average detector.



ISED Restricted bands please refer to ISED RSS-GEN Clause 8.10

Table 7 – Restricted frequency bands ^{Note 1}		
MHz	MHz	GHz
0.090 - 0.110	149.9 - 150.05	9.0 - 9.2
0.495 - 0.505	156.52475 - 156.52525	9.3 - 9.5
2.1735 - 2.1905	156.7 - 156.9	10.6 - 12.7
3.020 - 3.026	162.0125 - 167.17	13.25 - 13.4
4.125 - 4.128	167.72 - 173.2	14.47 - 14.5
4.17725 - 4.17775	240 - 285	15.35 - 16.2
4.20725 - 4.20775	322 - 335.4	17.7 - 21.4
5.677 - 5.683	399.9 - 410	22.01 - 23.12
6.215 - 6.218	608 - 614	23.6 - 24.0
6.26775 - 6.26825	960 - 1427	31.2 - 31.8
6.31175 - 6.31225	1435 - 1626.5	36.43 - 36.5
8.291 - 8.294	1645.5 - 1646.5	Above 38.6
8.362 - 8.366	1680 - 1710	
8.37625 - 8.38675	1718.8 - 1722.2	
8.41425 - 8.41475	2200 - 2300	
12.29 - 12.293	2310 - 2390	
12.51975 - 12.52025	2483.5 - 2500	
12.57675 - 12.57725	2655 - 2900	
13.36 - 13.41	3260 - 3267	
16.42 - 16.423	3332 - 3339	
16.69475 - 16.69525	3345.8 - 3358	
16.80425 - 16.80475	3500 - 4400	
25.5 - 25.67	4500 - 5150	
37.5 - 38.25	5350 - 5460	
73 - 74.6	7250 - 7750	
74.8 - 75.2	8025 - 8500	
108 - 138		

Note 1: Certain frequency bands listed in table 7 and in bands above 38.6 GHz are designated for licence-exempt applications. These frequency bands and the requirements that apply to related devices are set out in the 200 and 300 series of RSSs.

FCC Restricted bands of operation refer to FCC §15.205 (a):

MHz	MHz	MHz	GHz
0.090-0.110	16.42-16.423	399.9-410	4.5-5.15
0.495-0.505	16.69475-16.69525	608-614	5.35-5.46
2.1735-2.1905	16.80425-16.80475	960-1240	7.25-7.75
4.125-4.128	25.5-25.67	1300-1427	8.025-8.5
4.17725-4.17775	37.5-38.25	1435-1626.5	9.0-9.2
4.20725-4.20775	73-74.6	1645.5-1646.5	9.3-9.5
6.215-6.218	74.8-75.2	1680-1710	10.6-12.7
6.26775-6.26825	108-121.94	1718.8-1722.2	13.25-13.4
6.31175-6.31225	123-138	2200-2300	14.47-14.5
8.291-8.294	149.9-150.05	2310-2390	15.35-16.2
8.362-8.366	156.52475-156.52525	2483.5-2500	17.7-21.4
8.37625-8.38675	156.7-156.9	2690-2900	22.01-23.12
8.41425-8.41475	162.0125-167.17	3260-3267	23.6-24.0
12.29-12.293	167.72-173.2	3332-3339	31.2-31.8
12.51975-12.52025	240-285	3345.8-3358	36.43-36.5
12.57675-12.57725	322-335.4	3600-4400	(²)
13.36-13.41			

Note: ¹Until February 1, 1999, this restricted band shall be 0.490-0.510 MHz.
²Above 38.6c

TEST SETUP AND PROCEDURE

Below 30MHz

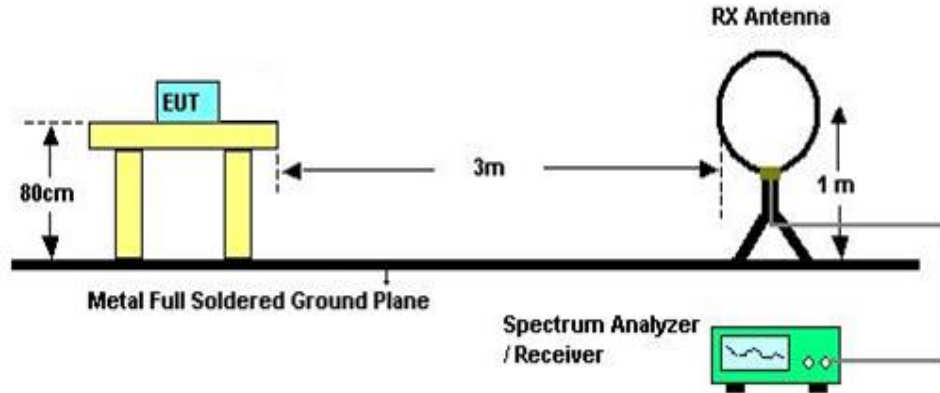

The setting of the spectrum analyser

RBW	200Hz (From 9kHz to 0.15MHz)/ 9kHz (From 0.15MHz to 30MHz)
VBW	200Hz (From 9kHz to 0.15MHz)/ 9kHz (From 0.15MHz to 30MHz)
Sweep	Auto
Detector	Peak/QP/ Average
Trace	Max hold

1. The testing follows the guidelines in ANSI C63.10-2013
2. The EUT was arranged to its worst case and then turntable (from 0 degree to 360 degrees) to find the maximum reading. A pre-amp and a high pass filter are used for the test in order to get better signal level. Both Horizontal, Face-on and Face-off polarizations of the antenna are set to make the measurement.
3. The EUT was placed on a turntable with 0.8 meter above ground.
4. The EUT was set 3 meters from the interference receiving antenna, which was mounted on the top of 1 m height antenna tower.
5. For measurement below 1GHz, the initial step in collecting conducted emission data is a spectrum analyzer peak detector mode pre-scanning the measurement frequency range. Significant peaks are then marked and then Quasi Peak detector mode re-measured. If the emission level of the EUT measured by the peak detector is 3 dB lower than the applicable limit, the peak emission level will be reported. Otherwise, the emission measurement will be repeated using the quasi-peak detector and reported.
6. Although these tests were performed other than open field site, adequate comparison measurements were confirmed against 30m open field site. Therefore sufficient tests were made to demonstrate that the alternative site produces results that correlate with the ones of tests made in an open field site based on KDB 414788.

Below 1GHz and Above 30MHz

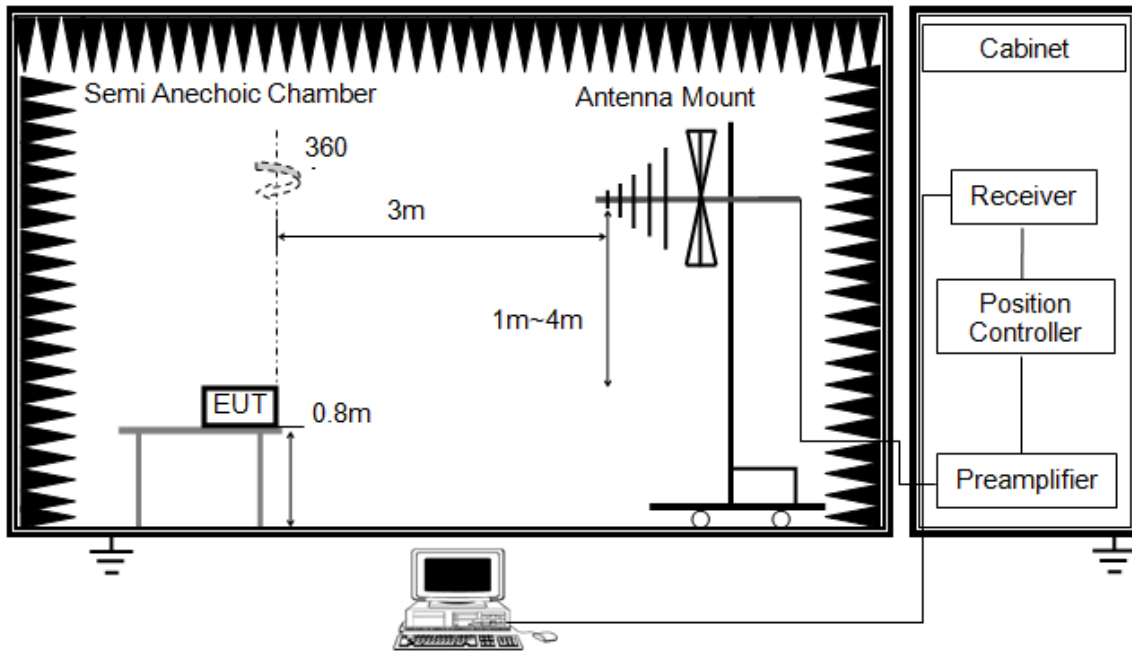

The setting of the spectrum analyser

RBW	120kHz
VBW	300kHz
Sweep	Auto
Detector	Peak/QP
Trace	Max hold

1. The testing follows the guidelines in ANSI C63.10-2013.
2. The EUT was arranged to its worst case and then tune the antenna tower (from 1 m to 4 m) and turntable (from 0 degree to 360 degrees) to find the maximum reading. A pre-amp and a high pass filter are used for the test in order to get better signal level. Both horizontal and vertical polarizations of the antenna are set to make the measurement.
3. The EUT was placed on a turntable with 0.8 meter above ground.
4. The EUT was set 3 meters from the interference receiving antenna, which was mounted on the top of a variable height antenna tower.
5. For measurement below 1GHz, the initial step in collecting conducted emission data is a spectrum analyzer peak detector mode pre-scanning the measurement frequency range. Significant peaks are then marked and then Quasi Peak detector mode re-measured. If the emission level of the EUT measured by the peak detector is 3 dB lower than the applicable limit, the peak emission level will be reported. Otherwise, the emission measurement will be repeated using the quasi-peak detector and reported.

ABOVE 1GHz

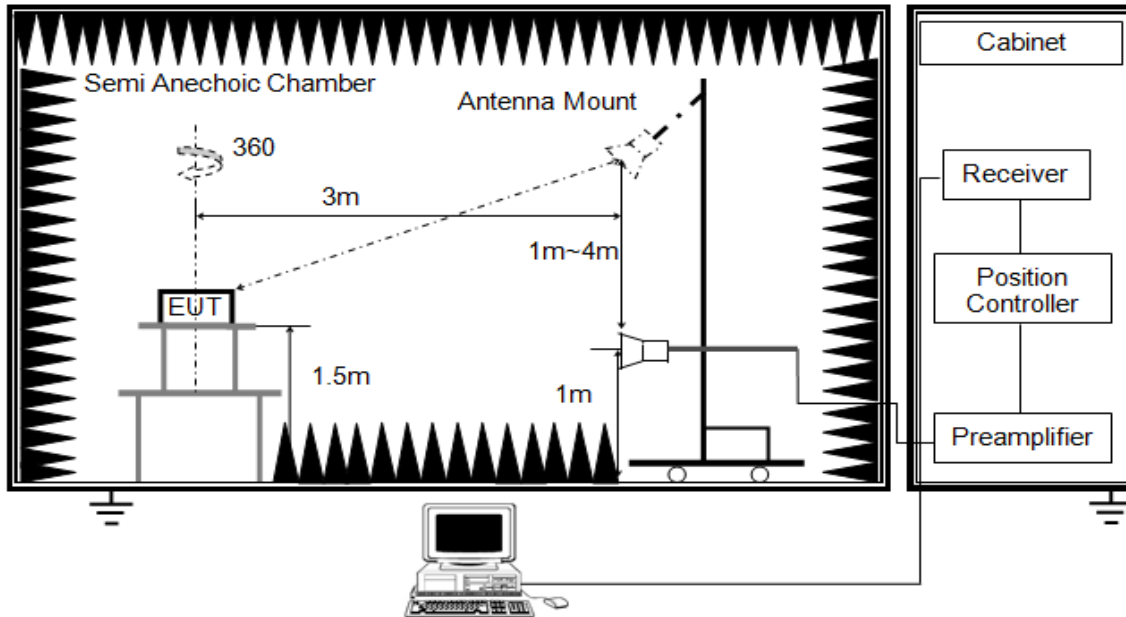

The setting of the spectrum analyser

RBW	1MHz
VBW	PEAK: 3MHz AVG: see note 6
Sweep	Auto
Detector	Peak
Trace	Max hold

1. The testing follows the guidelines in ANSI C63.10-2013.
2. The EUT was arranged to its worst case and then tune the antenna tower (from 1 m to 4 m) and turntable (from 0 degree to 360 degrees) to find the maximum reading. A pre-amp and a high pass filter are used for the test in order to get better signal level. Both horizontal and vertical polarizations of the antenna are set to make the measurement.
3. The EUT was placed on a turntable with 1.5m above ground.
4. The EUT was set 3 meters from the interference receiving antenna, which was mounted on the top of a variable height antenna tower.
5. For measurement above 1GHz, the emission measurement will be measured by the peak detector. This peak level, once corrected, must comply with the limit specified in Section 15.209.
6. For measurements above 1 GHz the resolution bandwidth is set to 1 MHz, then the video bandwidth is set to 3 MHz for peak measurements and 1 MHz resolution bandwidth with 1/T video bandwidth with peak detector for average measurements. For the Duty Cycle please refer to clause 7.1.ON TIME AND DUTY CYCLE.

X axis, Y axis, Z axis positions:

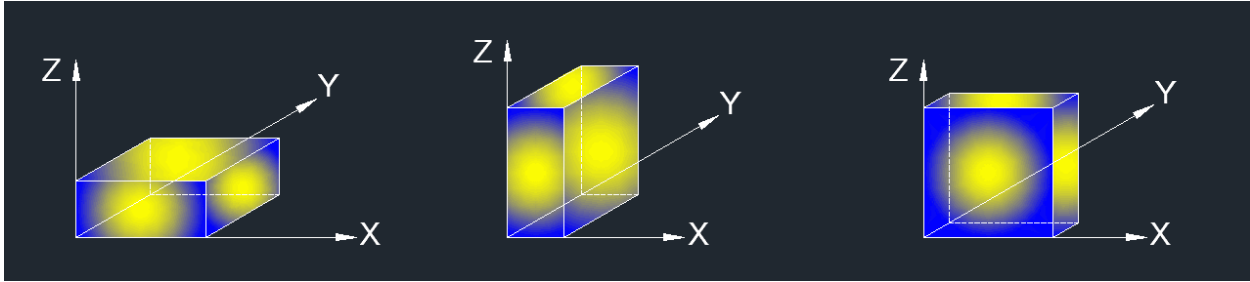

Note: For all radiated test, EUT in each of three orthogonal axis emissions had been tested, but only the worst case (X axis) data recorded in the report.

TEST ENVIRONMENT

Temperature	23.2°C	Relative Humidity	58%
Atmosphere Pressure	101kPa	Test Voltage	AC 120V, 60Hz



8.1. RESTRICTED BANDEDGE

8.1.1. 802.11b MODE

RESTRICTED BANDEDGE (CHANNEL 1, HORIZONTAL)

PEAK

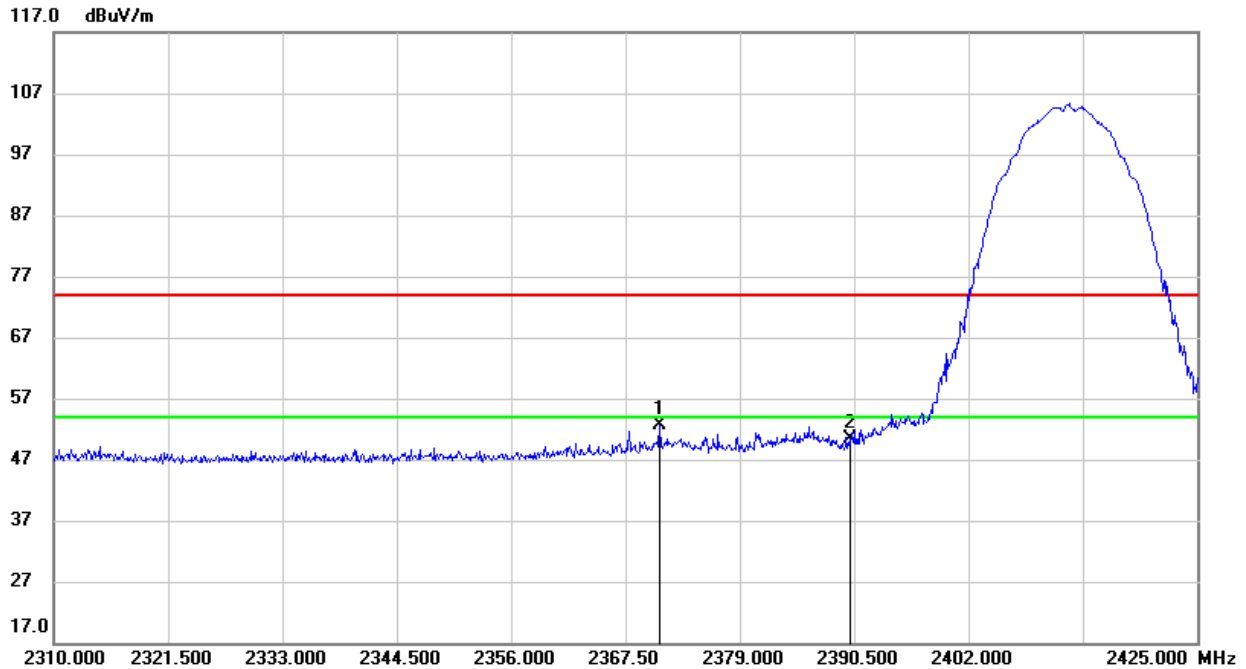

No.	Frequency (MHz)	Reading (dBuV)	Correct (dB/m)	Result (dBuV/m)	Limit (dBuV/m)	Margin (dB)	Remark
1	2370.950	20.64	32.06	52.70	74.00	-21.30	peak
2	2390.000	18.37	32.10	50.47	74.00	-23.53	peak

- Note: 1. Measurement = Reading Level + Correct Factor.
 2. If Peak Result complies with AV limit, AV Result is deemed to comply with AV limit.
 3. Peak: Peak detector.
 4. Only the worst case emission was recorded, if it complies with the limit, the other emissions deemed to comply with the limit.



RESTRICTED BANDEDGE (CHANNEL 1, VERTICAL)

PEAK

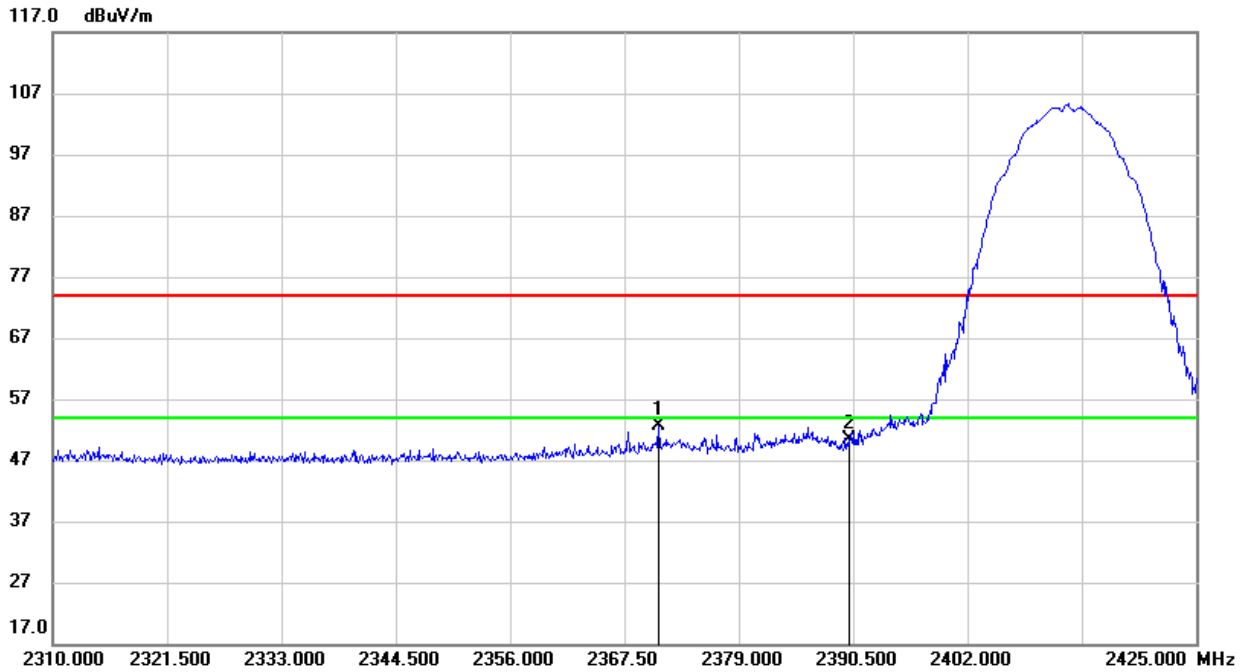

No.	Frequency (MHz)	Reading (dBuV)	Correct (dB/m)	Result (dBuV/m)	Limit (dBuV/m)	Margin (dB)	Remark
1	2370.950	20.64	32.06	52.70	74.00	-21.30	peak
2	2390.000	18.37	32.10	50.47	74.00	-23.53	peak

- Note:
1. Measurement = Reading Level + Correct Factor.
 2. If Peak Result complies with AV limit, AV Result is deemed to comply with AV limit.
 3. Peak: Peak detector.
 4. Only the worst case emission was recorded, if it complies with the limit, the other emissions deemed to comply with the limit.



RESTRICTED BANDEDGE (CHANNEL 2, HORIZONTAL)

PEAK

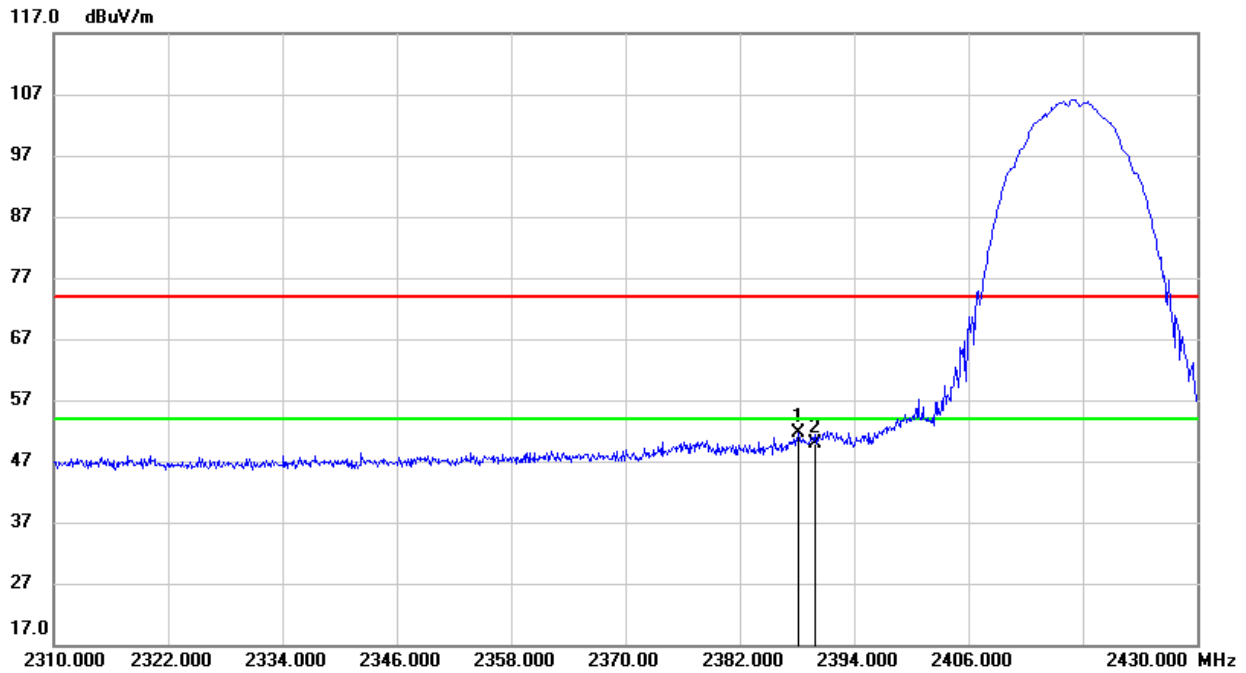

No.	Frequency (MHz)	Reading (dBuV)	Correct (dB/m)	Result (dBuV/m)	Limit (dBuV/m)	Margin (dB)	Remark
1	2388.120	19.49	32.10	51.59	74.00	-22.41	peak
2	2390.000	17.87	32.10	49.97	74.00	-24.03	peak

- Note: 1. Measurement = Reading Level + Correct Factor.
 2. If Peak Result complies with AV limit, AV Result is deemed to comply with AV limit.
 3. Peak: Peak detector.
 4. Only the worst case emission was recorded, if it complies with the limit, the other emissions deemed to comply with the limit.



RESTRICTED BANDEDGE (CHANNEL 2, VERTICAL)

PEAK

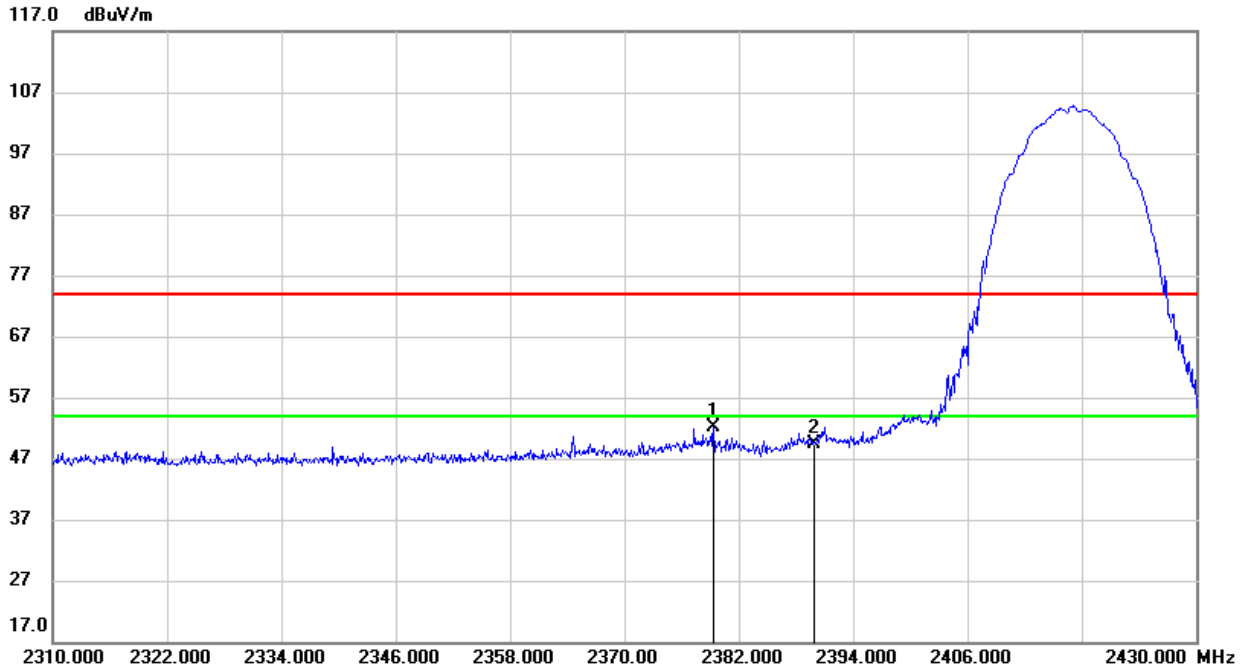

No.	Frequency (MHz)	Reading (dBuV)	Correct (dB/m)	Result (dBuV/m)	Limit (dBuV/m)	Margin (dB)	Remark
1	2379.360	19.96	32.08	52.04	74.00	-21.96	peak
2	2390.000	17.32	32.10	49.42	74.00	-24.58	peak

- Note: 1. Measurement = Reading Level + Correct Factor.
 2. If Peak Result complies with AV limit, AV Result is deemed to comply with AV limit.
 3. Peak: Peak detector.
 4. Only the worst case emission was recorded, if it complies with the limit, the other emissions deemed to comply with the limit.



RESTRICTED BANDEDGE (CHANNEL 10, HORIZONTAL)

PEAK

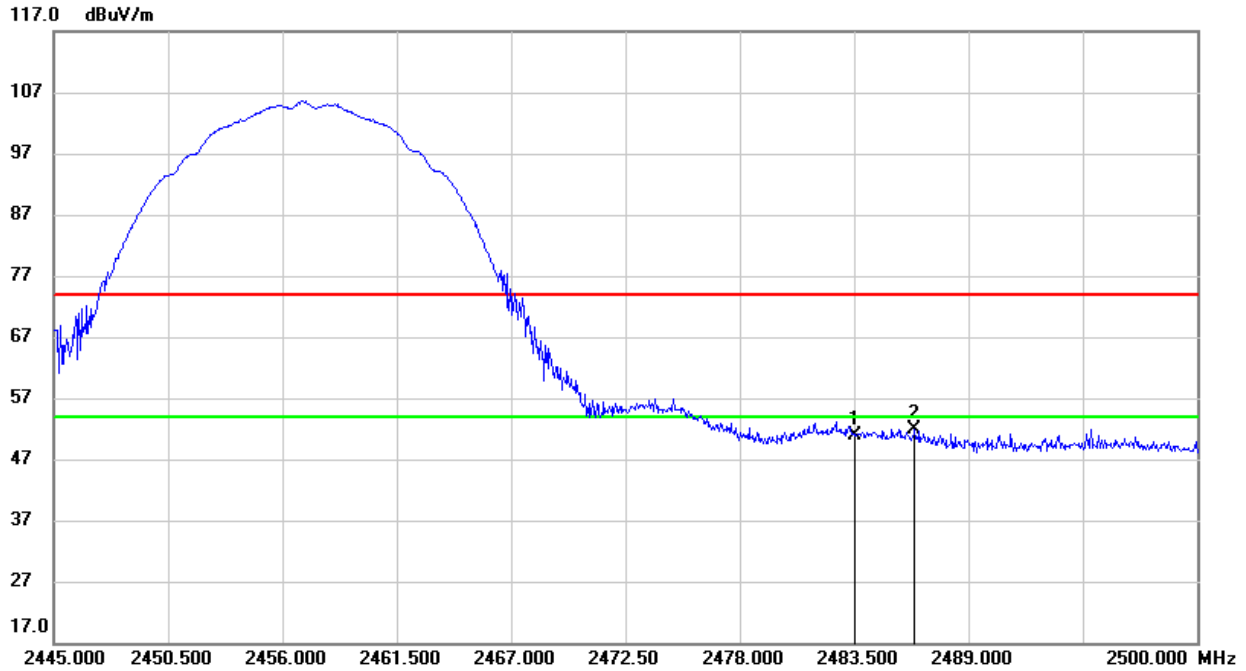

No.	Frequency (MHz)	Reading (dBuV)	Correct (dB/m)	Result (dBuV/m)	Limit (dBuV/m)	Margin (dB)	Remark
1	2483.500	18.57	32.31	50.88	74.00	-23.12	peak
2	2486.415	19.65	32.32	51.97	74.00	-22.03	peak

- Note: 1. Measurement = Reading Level + Correct Factor.
 2. If Peak Result complies with AV limit, AV Result is deemed to comply with AV limit.
 3. Peak: Peak detector.
 4. Only the worst case emission was recorded, if it complies with the limit, the other emissions deemed to comply with the limit.



RESTRICTED BANDEDGE (CHANNEL 10, VERTICAL)

PEAK

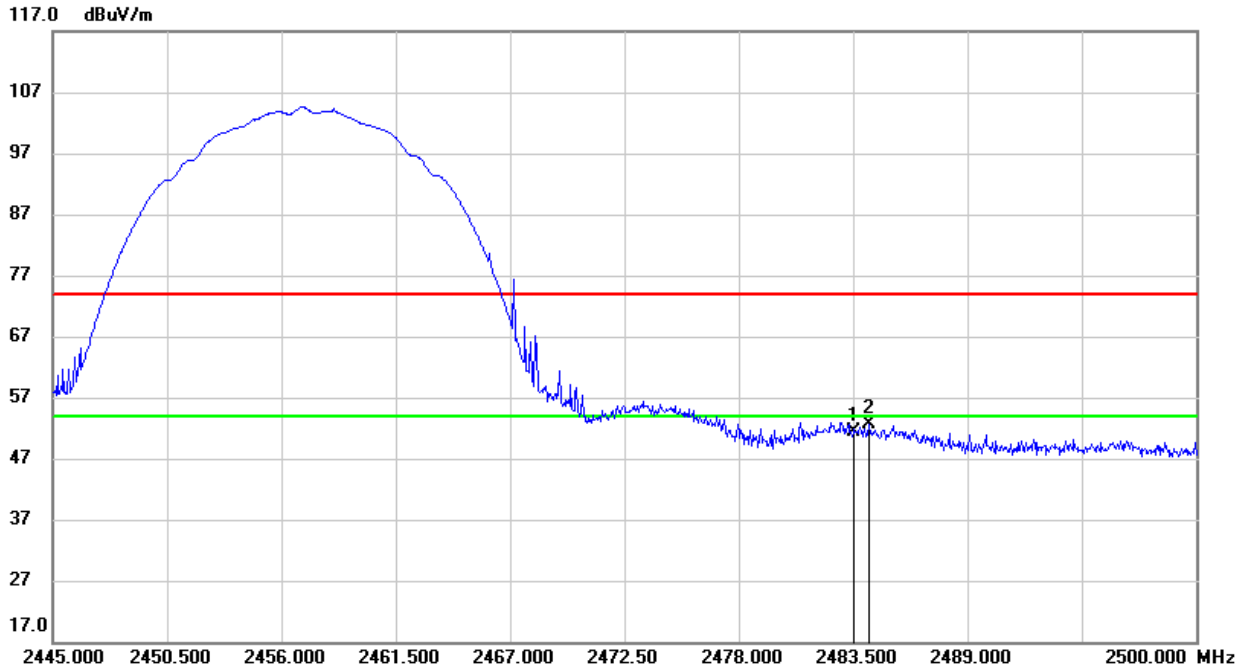

No.	Frequency (MHz)	Reading (dBuV)	Correct (dB/m)	Result (dBuV/m)	Limit (dBuV/m)	Margin (dB)	Remark
1	2483.500	18.96	32.31	51.27	74.00	-22.73	peak
2	2484.270	20.32	32.31	52.63	74.00	-21.37	peak

- Note: 1. Measurement = Reading Level + Correct Factor.
 2. If Peak Result complies with AV limit, AV Result is deemed to comply with AV limit.
 3. Peak: Peak detector.
 4. Only the worst case emission was recorded, if it complies with the limit, the other emissions deemed to comply with the limit.



RESTRICTED BANDEDGE (CHANNEL 11, HORIZONTAL)

PEAK

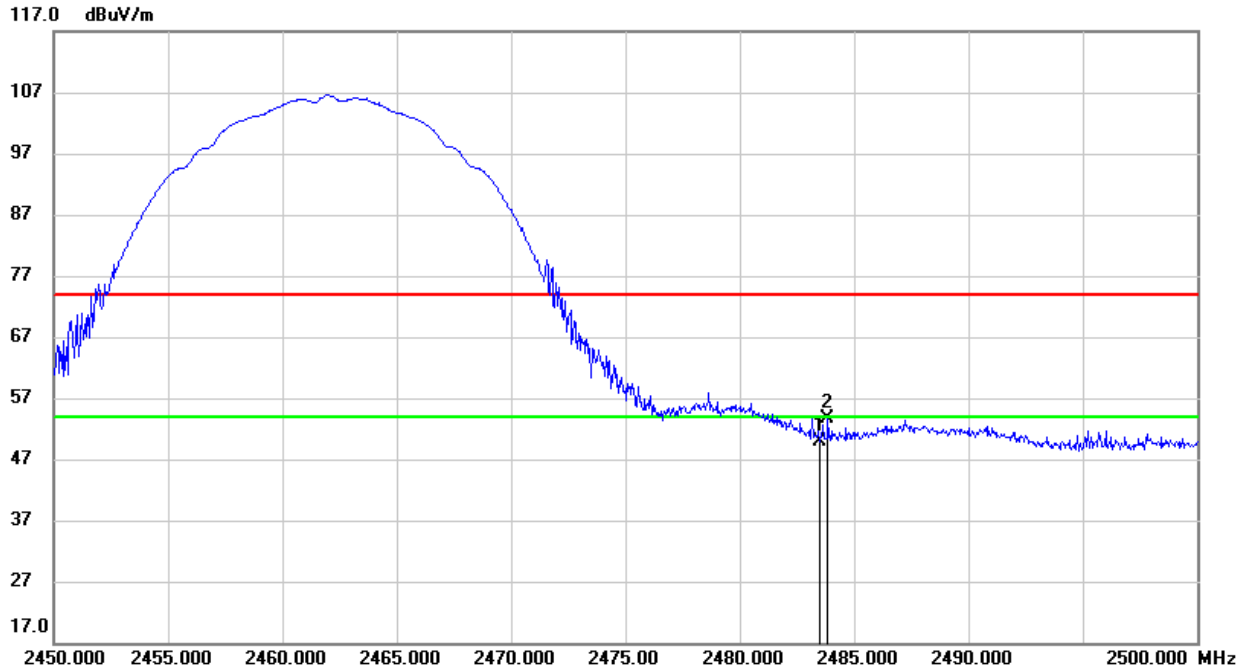

No.	Frequency (MHz)	Reading (dBuV)	Correct (dB/m)	Result (dBuV/m)	Limit (dBuV/m)	Margin (dB)	Remark
1	2483.500	17.62	32.31	49.93	74.00	-24.07	peak
2	2483.850	21.31	32.31	53.62	74.00	-20.38	peak

- Note: 1. Measurement = Reading Level + Correct Factor.
 2. If Peak Result complies with AV limit, AV Result is deemed to comply with AV limit.
 3. Peak: Peak detector.
 4. Only the worst case emission was recorded, if it complies with the limit, the other emissions deemed to comply with the limit.



RESTRICTED BANDEDGE (CHANNEL 11, VERTICAL)

PEAK

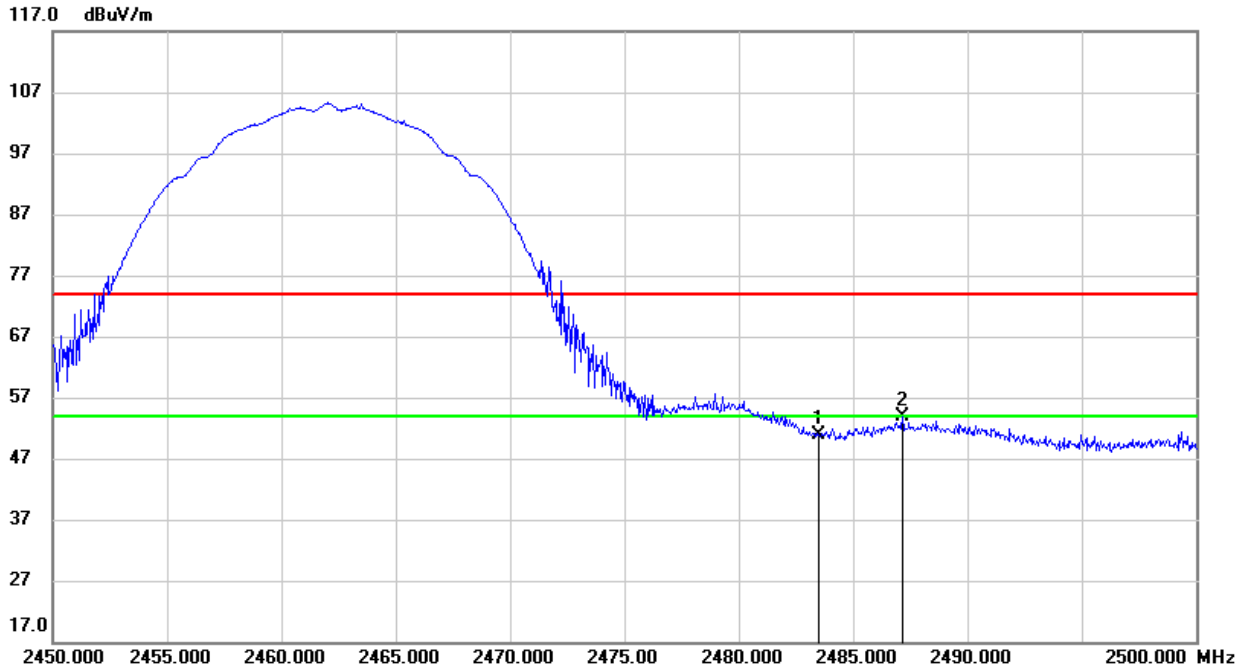

No.	Frequency (MHz)	Reading (dBuV)	Correct (dB/m)	Result (dBuV/m)	Limit (dBuV/m)	Margin (dB)	Remark
1	2483.500	18.64	32.31	50.95	74.00	-23.05	peak
2	2487.150	21.45	32.32	53.77	74.00	-20.23	peak

- Note: 1. Measurement = Reading Level + Correct Factor.
 2. If Peak Result complies with AV limit, AV Result is deemed to comply with AV limit.
 3. Peak: Peak detector.
 4. Only the worst case emission was recorded, if it complies with the limit, the other emissions deemed to comply with the limit.



8.1.2. 802.11g MODE

RESTRICTED BANDEDGE (CHANNEL 1, HORIZONTAL)

PEAK

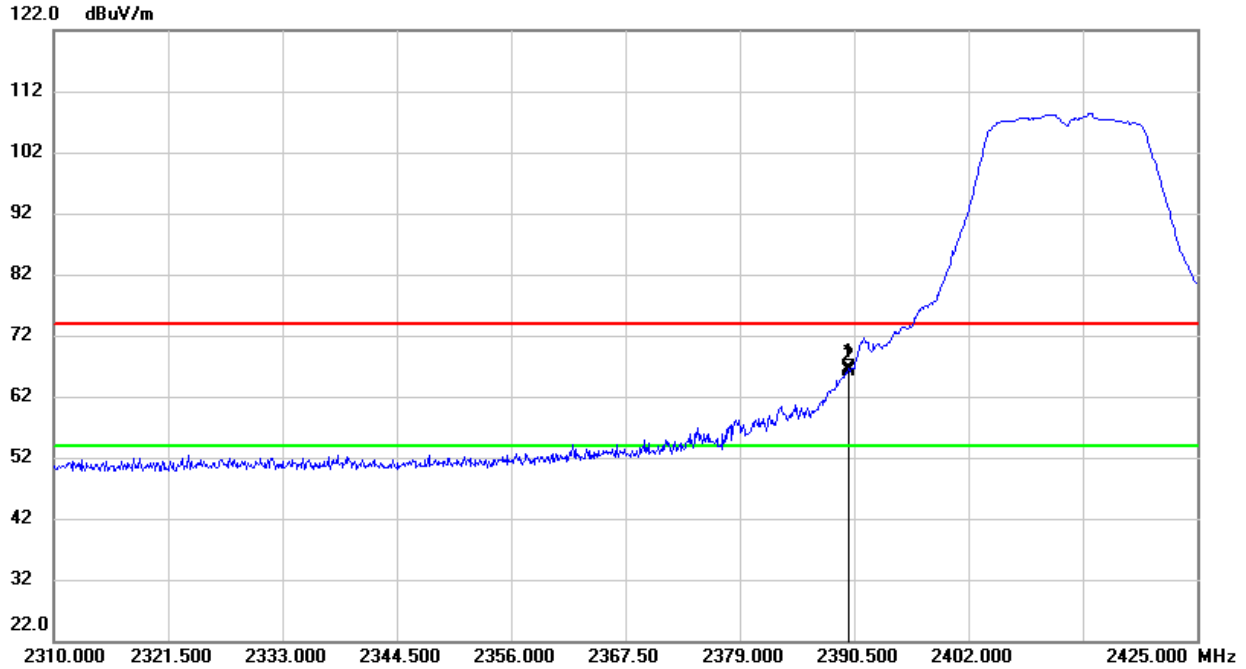

No.	Frequency (MHz)	Reading (dBuV)	Correct (dB/m)	Result (dBuV/m)	Limit (dBuV/m)	Margin (dB)	Remark
1	2389.925	34.56	32.10	66.66	74.00	-7.34	peak
2	2390.000	34.01	32.10	66.11	74.00	-7.89	peak

- Note: 1. Measurement = Reading Level + Correct Factor.
 2. If Peak Result complies with AV limit, AV Result is deemed to comply with AV limit.
 3. Peak: Peak detector.
 4. Only the worst case emission was recorded, if it complies with the limit, the other emissions deemed to comply with the limit.



AVG

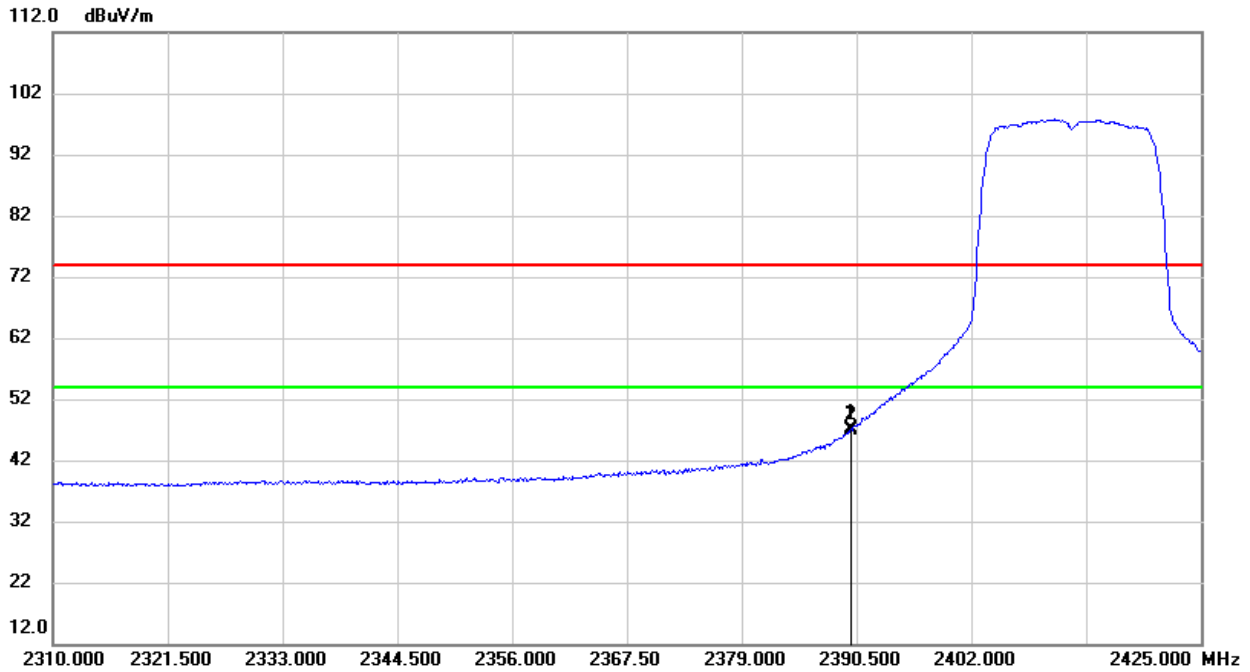

No.	Frequency (MHz)	Reading (dBuV)	Correct (dB/m)	Result (dBuV/m)	Limit (dBuV/m)	Margin (dB)	Remark
1	2389.925	15.00	32.10	47.10	54.00	-6.90	AVG
2	2390.000	14.87	32.10	46.97	54.00	-7.03	AVG

- Note:
1. Measurement = Reading Level + Correct Factor.
 2. If Peak Result complies with AV limit, AV Result is deemed to comply with AV limit.
 3. Peak: Peak detector.
 4. AVG: $VBW=1/Ton$, where: Ton is the transmitting duration.
 5. For the transmitting duration, please refer to clause 7.1.
 6. Only the worst case emission was recorded, if it complies with the limit, the other emissions deemed to comply with the limit.



RESTRICTED BANDEDGE (CHANNEL 1, VERTICAL)

PEAK

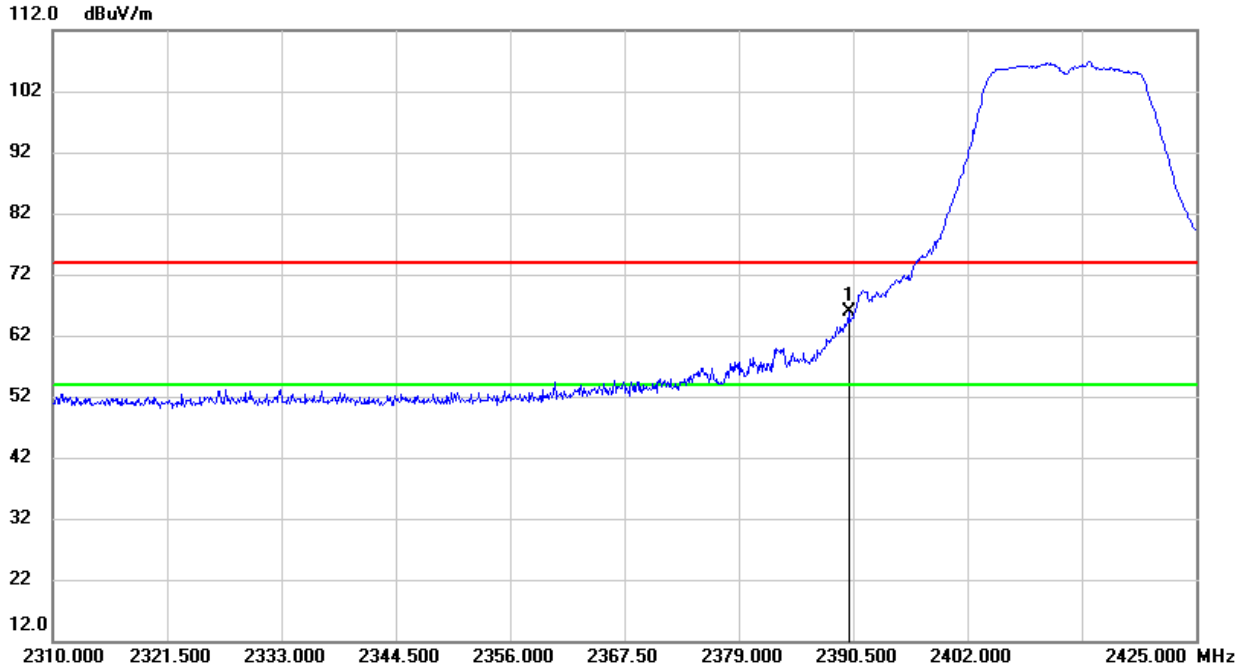

No.	Frequency (MHz)	Reading (dBuV)	Correct (dB/m)	Result (dBuV/m)	Limit (dBuV/m)	Margin (dB)	Remark
1	2390.000	33.86	32.10	65.96	74.00	-8.04	peak

- Note:
1. Measurement = Reading Level + Correct Factor.
 2. If Peak Result complies with AV limit, AV Result is deemed to comply with AV limit.
 3. Peak: Peak detector.
 4. Only the worst case emission was recorded, if it complies with the limit, the other emissions deemed to comply with the limit.



AVG

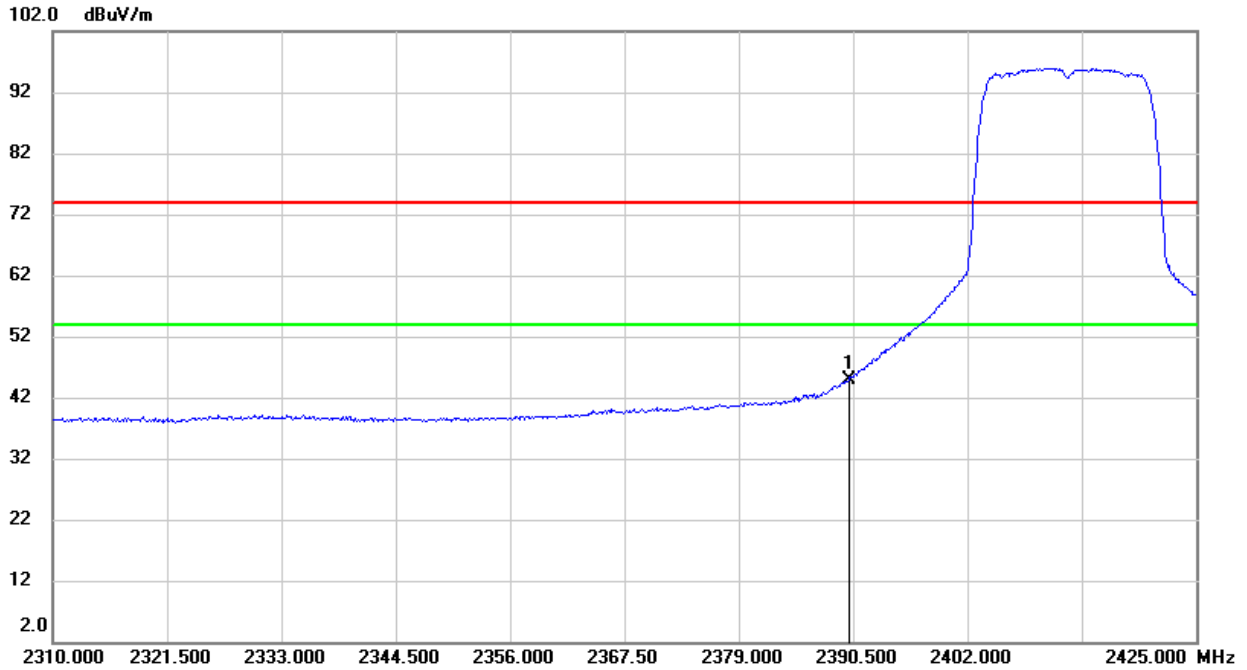

No.	Frequency (MHz)	Reading (dBuV)	Correct (dB/m)	Result (dBuV/m)	Limit (dBuV/m)	Margin (dB)	Remark
1	2390.000	12.67	32.10	44.77	54.00	-9.23	AVG

- Note:
1. Measurement = Reading Level + Correct Factor.
 2. If Peak Result complies with AV limit, AV Result is deemed to comply with AV limit.
 3. Peak: Peak detector.
 4. AVG: $VBW=1/Ton$, where: Ton is the transmitting duration.
 5. For the transmitting duration, please refer to clause 7.1.
 6. Only the worst case emission was recorded, if it complies with the limit, the other emissions deemed to comply with the limit.



RESTRICTED BANDEDGE (CHANNEL 2, HORIZONTAL)

PEAK

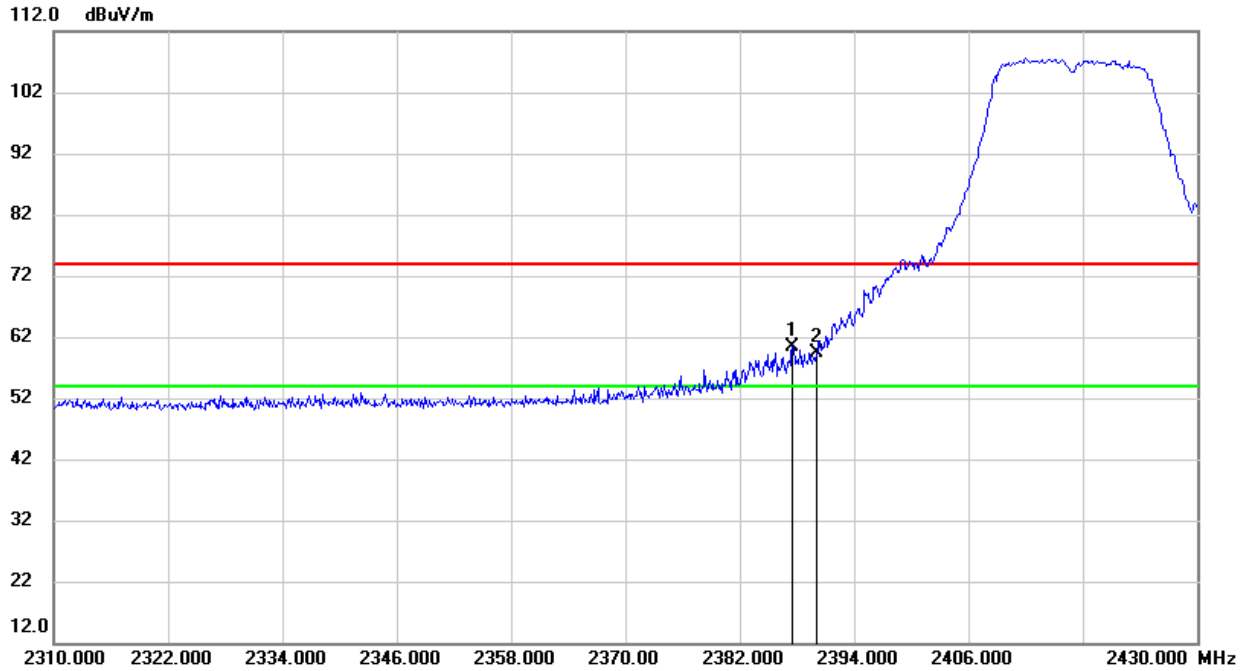

No.	Frequency (MHz)	Reading (dBuV)	Correct (dB/m)	Result (dBuV/m)	Limit (dBuV/m)	Margin (dB)	Remark
1	2387.520	28.33	32.10	60.43	74.00	-13.57	peak
2	2390.000	27.21	32.10	59.31	74.00	-14.69	peak

- Note: 1. Measurement = Reading Level + Correct Factor.
 2. If Peak Result complies with AV limit, AV Result is deemed to comply with AV limit.
 3. Peak: Peak detector.
 4. Only the worst case emission was recorded, if it complies with the limit, the other emissions deemed to comply with the limit.



AVG

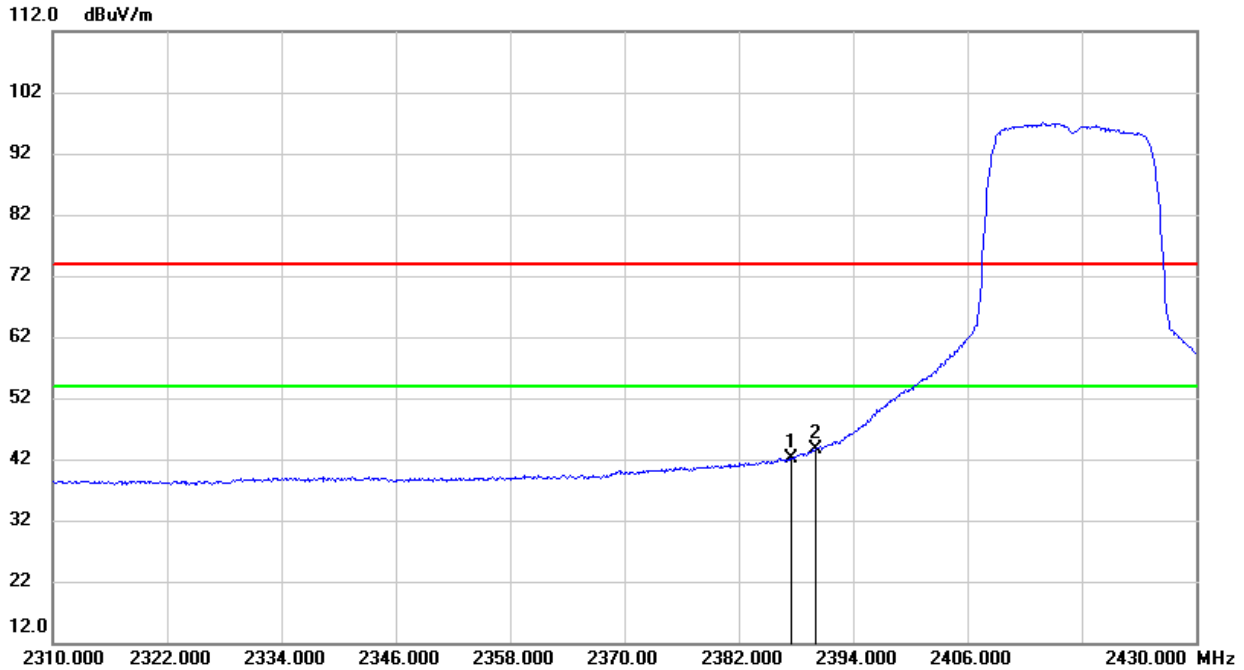

No.	Frequency (MHz)	Reading (dBuV)	Correct (dB/m)	Result (dBuV/m)	Limit (dBuV/m)	Margin (dB)	Remark
1	2387.520	10.08	32.10	42.18	54.00	-11.82	AVG
2	2390.000	11.49	32.10	43.59	54.00	-10.41	AVG

- Note:
1. Measurement = Reading Level + Correct Factor.
 2. If Peak Result complies with AV limit, AV Result is deemed to comply with AV limit.
 3. Peak: Peak detector.
 4. AVG: $VBW=1/T_{on}$, where: T_{on} is the transmitting duration.
 5. For the transmitting duration, please refer to clause 7.1.
 6. Only the worst case emission was recorded, if it complies with the limit, the other emissions deemed to comply with the limit.



RESTRICTED BANDEDGE (CHANNEL 2, VERTICAL)

PEAK

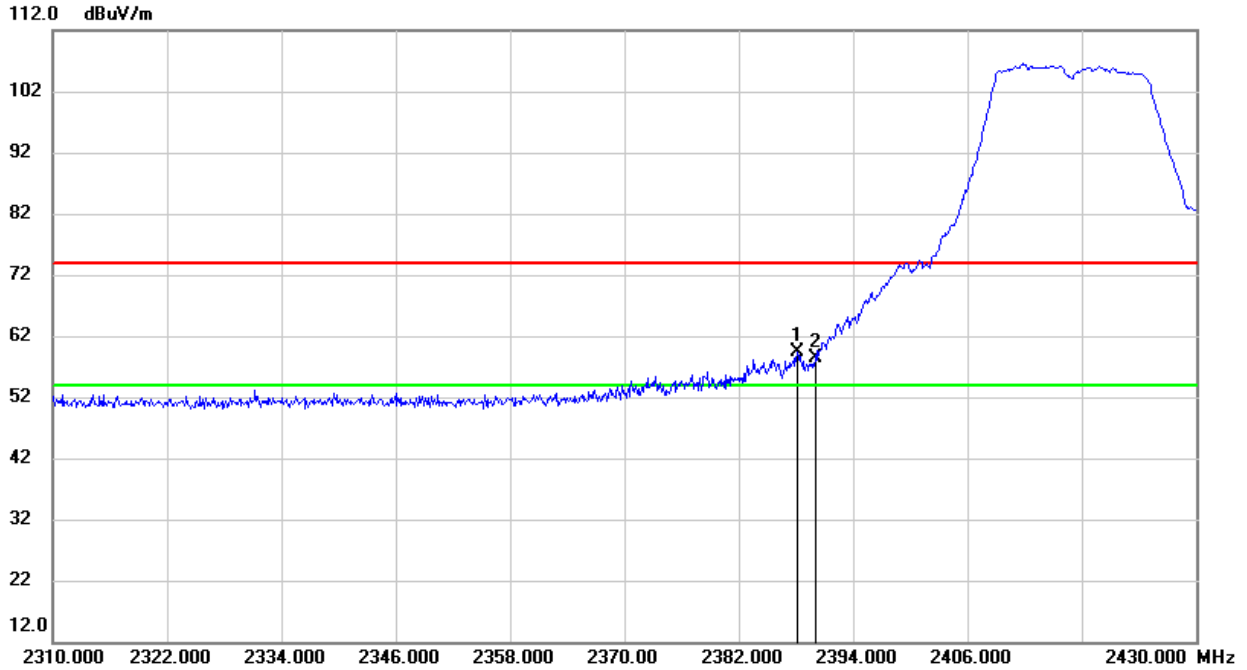

No.	Frequency (MHz)	Reading (dBuV)	Correct (dB/m)	Result (dBuV/m)	Limit (dBuV/m)	Margin (dB)	Remark
1	2388.120	27.35	32.10	59.45	74.00	-14.55	peak
2	2390.000	26.38	32.10	58.48	74.00	-15.52	peak

- Note: 1. Measurement = Reading Level + Correct Factor.
 2. If Peak Result complies with AV limit, AV Result is deemed to comply with AV limit.
 3. Peak: Peak detector.
 4. Only the worst case emission was recorded, if it complies with the limit, the other emissions deemed to comply with the limit.



AVG

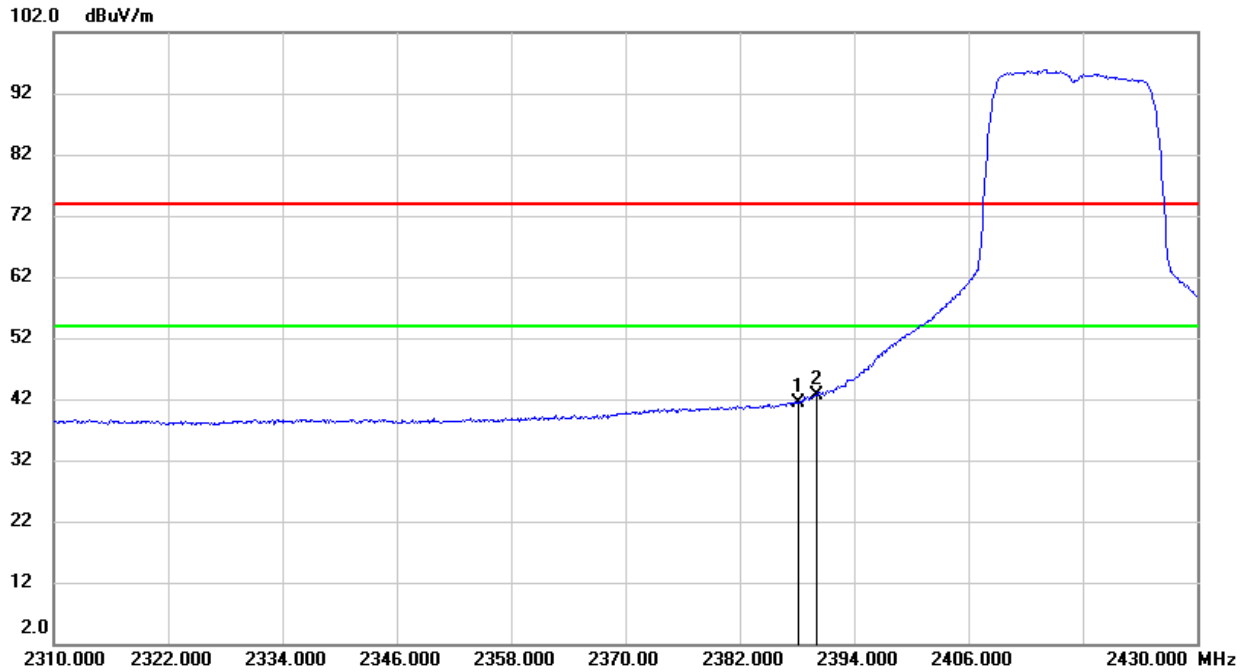

No.	Frequency (MHz)	Reading (dBuV)	Correct (dB/m)	Result (dBuV/m)	Limit (dBuV/m)	Margin (dB)	Remark
1	2388.120	9.39	32.10	41.49	54.00	-12.51	AVG
2	2390.000	10.48	32.10	42.58	54.00	-11.42	AVG

- Note:
1. Measurement = Reading Level + Correct Factor.
 2. If Peak Result complies with AV limit, AV Result is deemed to comply with AV limit.
 3. Peak: Peak detector.
 4. AVG: $VBW=1/T_{on}$, where: T_{on} is the transmitting duration.
 5. For the transmitting duration, please refer to clause 7.1.
 6. Only the worst case emission was recorded, if it complies with the limit, the other emissions deemed to comply with the limit.



RESTRICTED BANDEDGE (CHANNEL 10, HORIZONTAL)

PEAK

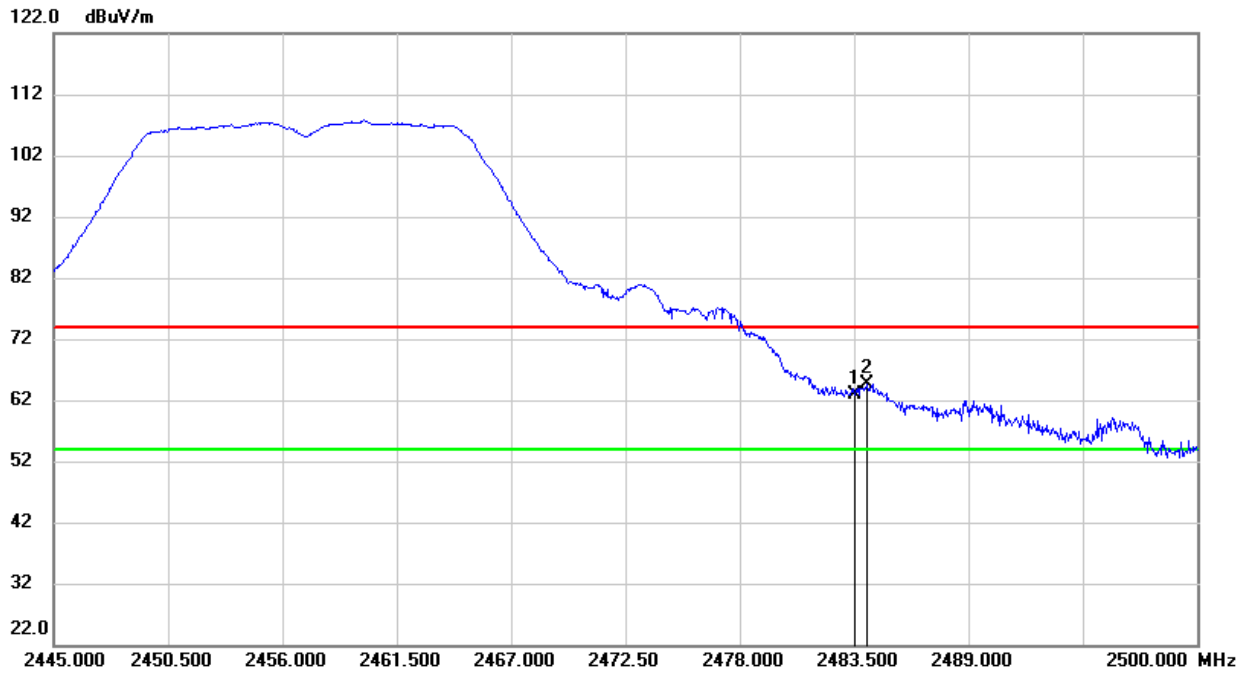

No.	Frequency (MHz)	Reading (dBuV)	Correct (dB/m)	Result (dBuV/m)	Limit (dBuV/m)	Margin (dB)	Remark
1	2483.500	30.53	32.31	62.84	74.00	-11.16	peak
2	2484.105	32.25	32.31	64.56	74.00	-9.44	peak

- Note: 1. Measurement = Reading Level + Correct Factor.
2. If Peak Result complies with AV limit, AV Result is deemed to comply with AV limit.
3. Peak: Peak detector.
4. Only the worst case emission was recorded, if it complies with the limit, the other emissions deemed to comply with the limit.



AVG

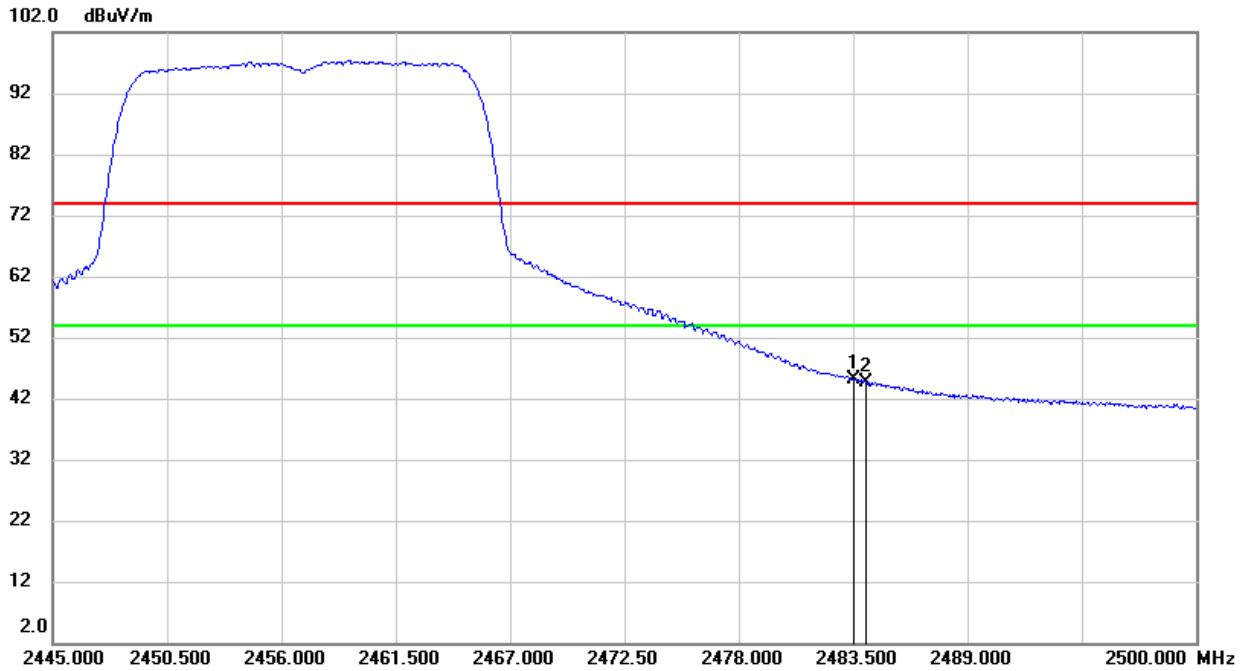

No.	Frequency (MHz)	Reading (dBuV)	Correct (dB/m)	Result (dBuV/m)	Limit (dBuV/m)	Margin (dB)	Remark
1	2483.500	12.87	32.31	45.18	54.00	-8.82	AVG
2	2484.105	12.29	32.31	44.60	54.00	-9.40	AVG

- Note: 1. Measurement = Reading Level + Correct Factor.
 2. If Peak Result complies with AV limit, AV Result is deemed to comply with AV limit.
 3. Peak: Peak detector.
 4. AVG: $VBW=1/Ton$, where: Ton is the transmitting duration.
 5. For the transmitting duration, please refer to clause 7.1.
 6. Only the worst case emission was recorded, if it complies with the limit, the other emissions deemed to comply with the limit.



RESTRICTED BANDEDGE (CHANNEL 10, VERTICAL)

PEAK

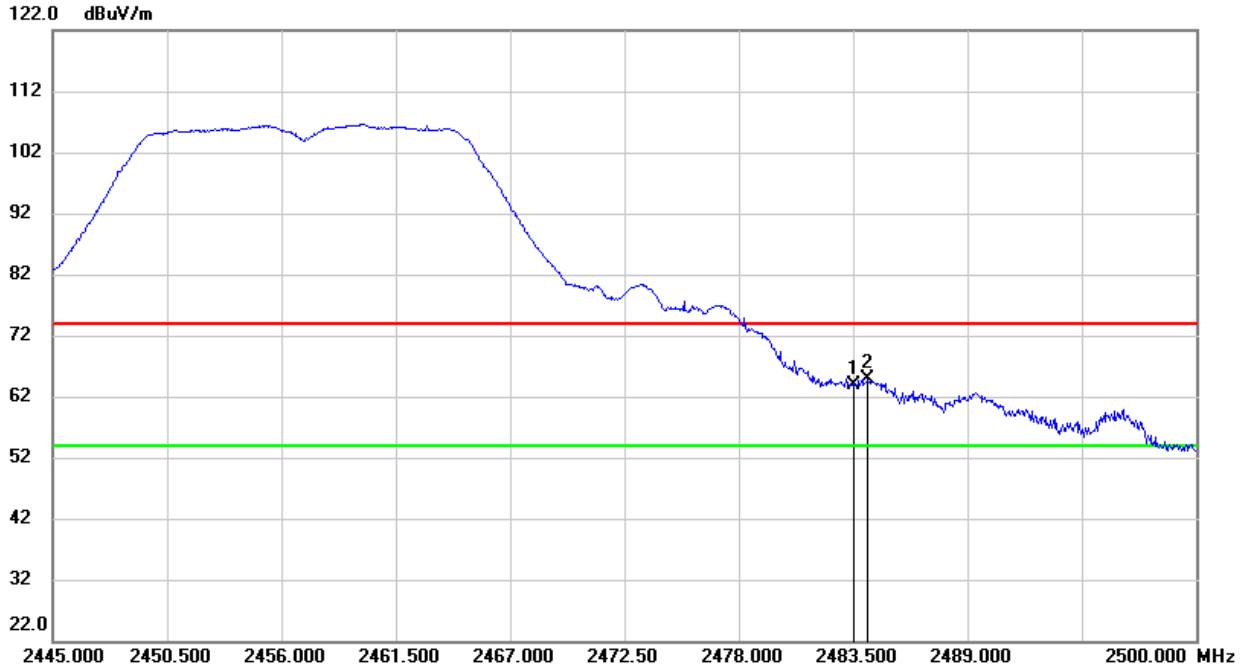

No.	Frequency (MHz)	Reading (dBuV)	Correct (dB/m)	Result (dBuV/m)	Limit (dBuV/m)	Margin (dB)	Remark
1	2483.500	31.48	32.31	63.79	74.00	-10.21	peak
2	2484.215	32.54	32.31	64.85	74.00	-9.15	peak

- Note: 1. Measurement = Reading Level + Correct Factor.
 2. If Peak Result complies with AV limit, AV Result is deemed to comply with AV limit.
 3. Peak: Peak detector.
 4. Only the worst case emission was recorded, if it complies with the limit, the other emissions deemed to comply with the limit.



AVG

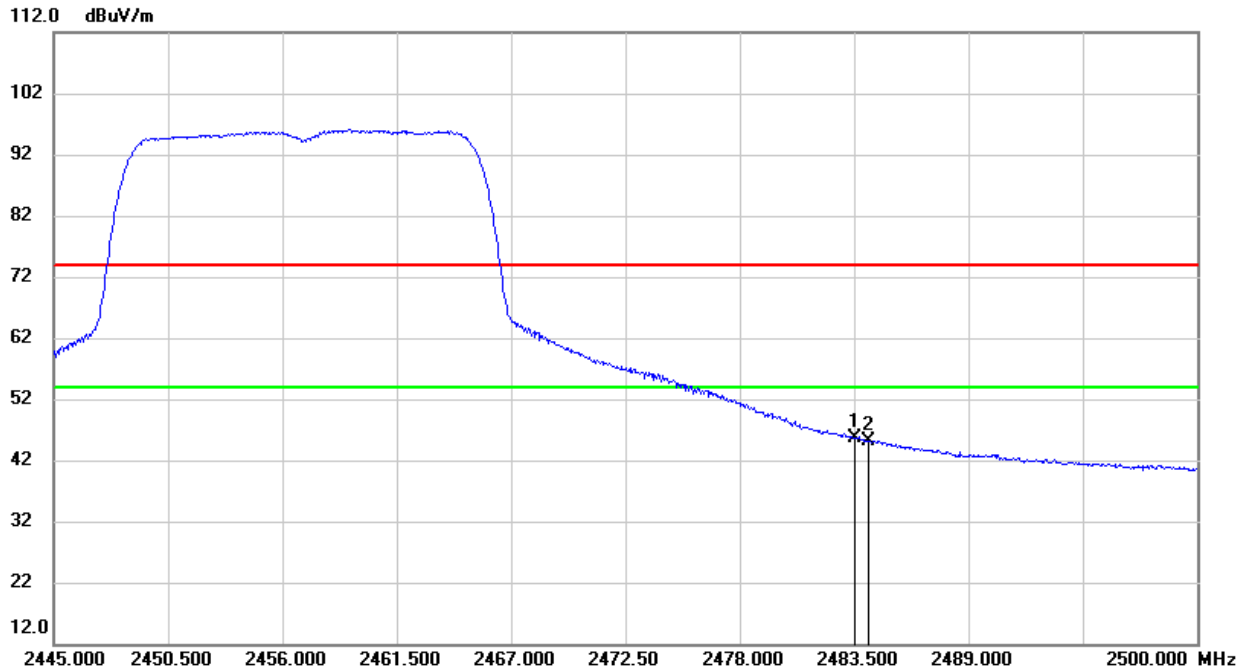

No.	Frequency (MHz)	Reading (dBuV)	Correct (dB/m)	Result (dBuV/m)	Limit (dBuV/m)	Margin (dB)	Remark
1	2483.500	13.22	32.31	45.53	54.00	-8.47	AVG
2	2484.215	12.83	32.31	45.14	54.00	-8.86	AVG

- Note:
1. Measurement = Reading Level + Correct Factor.
 2. If Peak Result complies with AV limit, AV Result is deemed to comply with AV limit.
 3. Peak: Peak detector.
 4. AVG: $VBW=1/T_{on}$, where: T_{on} is the transmitting duration.
 5. For the transmitting duration, please refer to clause 7.1.
 6. Only the worst case emission was recorded, if it complies with the limit, the other emissions deemed to comply with the limit.



RESTRICTED BANDEDGE (CHANNEL 11, HORIZONTAL)

PEAK

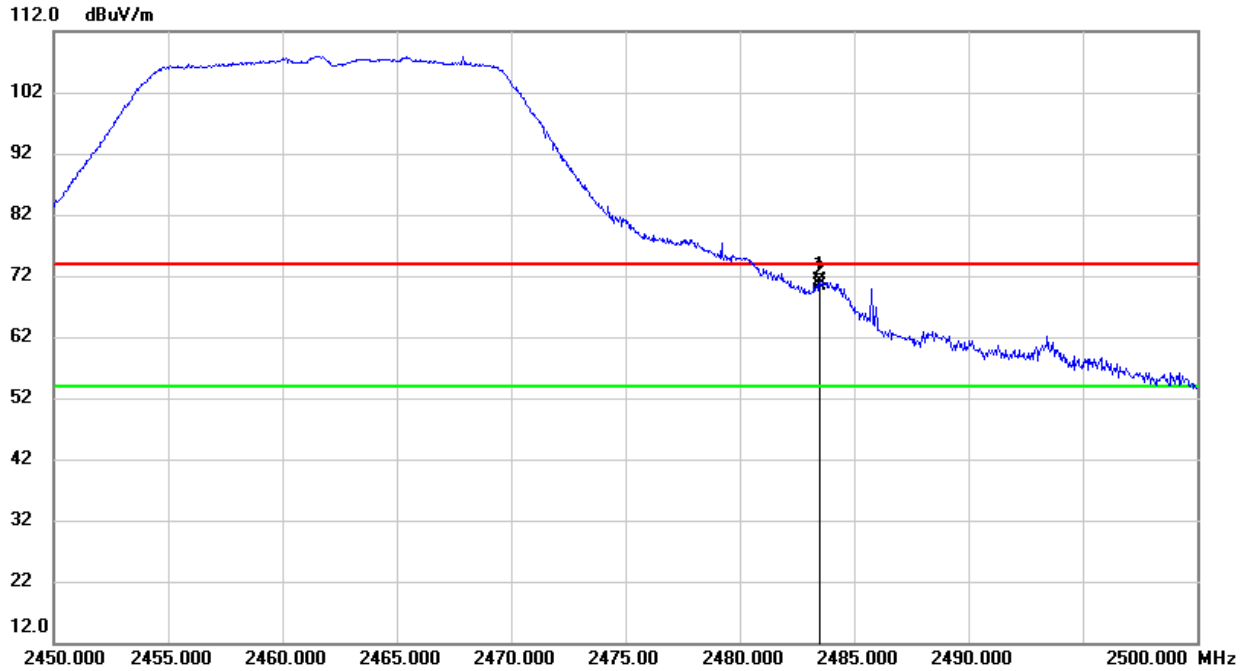

No.	Frequency (MHz)	Reading (dBuV)	Correct (dB/m)	Result (dBuV/m)	Limit (dBuV/m)	Margin (dB)	Remark
1	2483.500	38.71	32.31	71.02	74.00	-2.98	peak
2	2483.530	38.12	32.31	70.43	74.00	-3.57	peak

- Note: 1. Measurement = Reading Level + Correct Factor.
 2. If Peak Result complies with AV limit, AV Result is deemed to comply with AV limit.
 3. Peak: Peak detector.
 4. Only the worst case emission was recorded, if it complies with the limit, the other emissions deemed to comply with the limit.



AVG

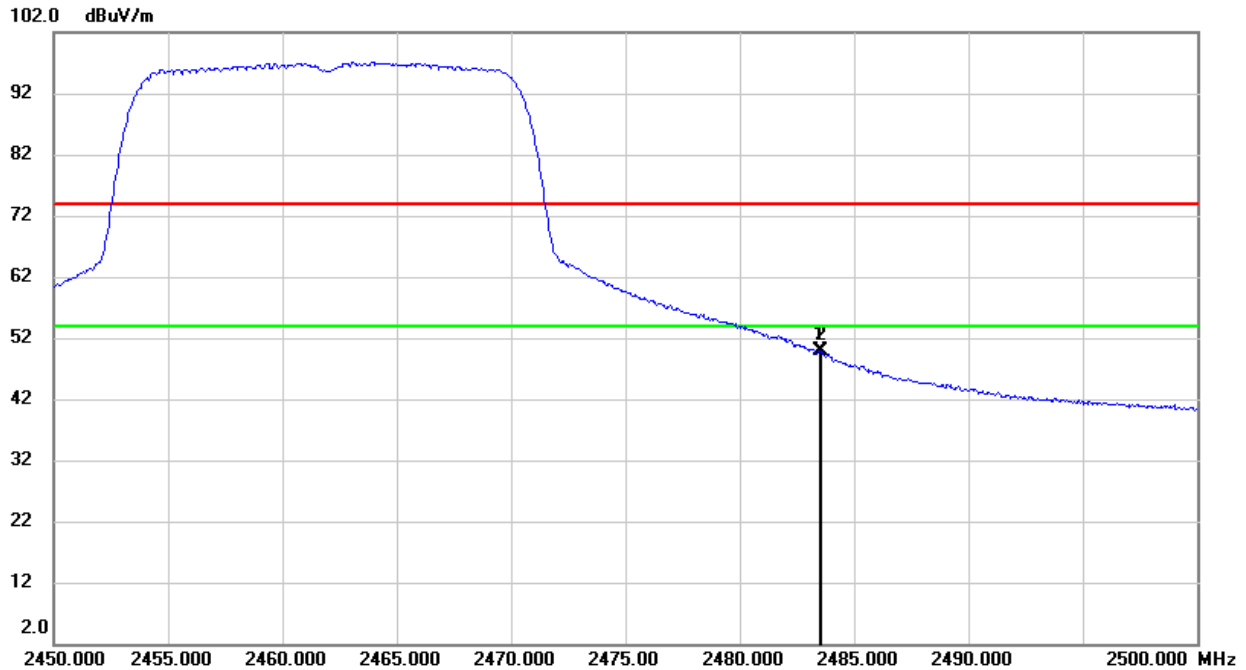

No.	Frequency (MHz)	Reading (dBuV)	Correct (dB/m)	Result (dBuV/m)	Limit (dBuV/m)	Margin (dB)	Remark
1	2483.500	17.46	32.31	49.77	54.00	-4.23	AVG
2	2483.530	17.48	32.31	49.79	54.00	-4.21	AVG

- Note: 1. Measurement = Reading Level + Correct Factor.
 2. If Peak Result complies with AV limit, AV Result is deemed to comply with AV limit.
 3. Peak: Peak detector.
 4. AVG: $VBW=1/Ton$, where: Ton is the transmitting duration.
 5. For the transmitting duration, please refer to clause 7.1.
 6. Only the worst case emission was recorded, if it complies with the limit, the other emissions deemed to comply with the limit.



RESTRICTED BANDEDGE (CHANNEL 11, VERTICAL)

PEAK

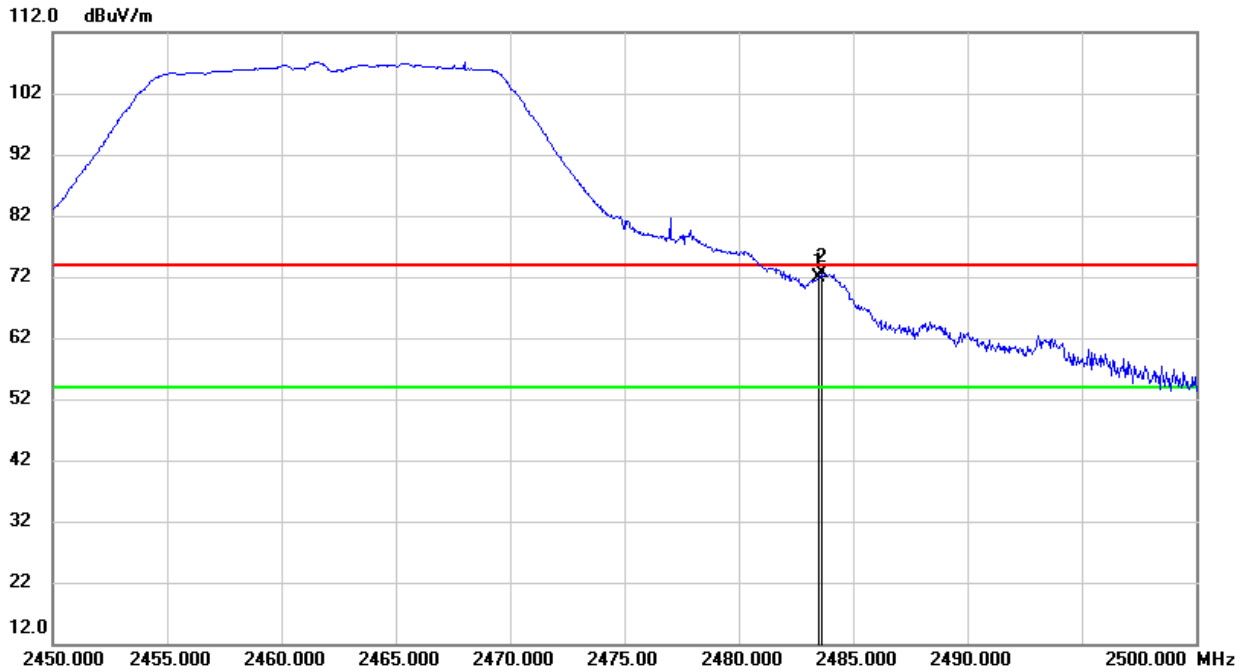

No.	Frequency (MHz)	Reading (dBuV)	Correct (dB/m)	Result (dBuV/m)	Limit (dBuV/m)	Margin (dB)	Remark
1	2483.500	39.60	32.31	71.91	74.00	-2.09	peak
2	2483.650	40.26	32.31	72.57	74.00	-1.43	peak

- Note: 1. Measurement = Reading Level + Correct Factor.
 2. If Peak Result complies with AV limit, AV Result is deemed to comply with AV limit.
 3. Peak: Peak detector.
 4. Only the worst case emission was recorded, if it complies with the limit, the other emissions deemed to comply with the limit.



AVG

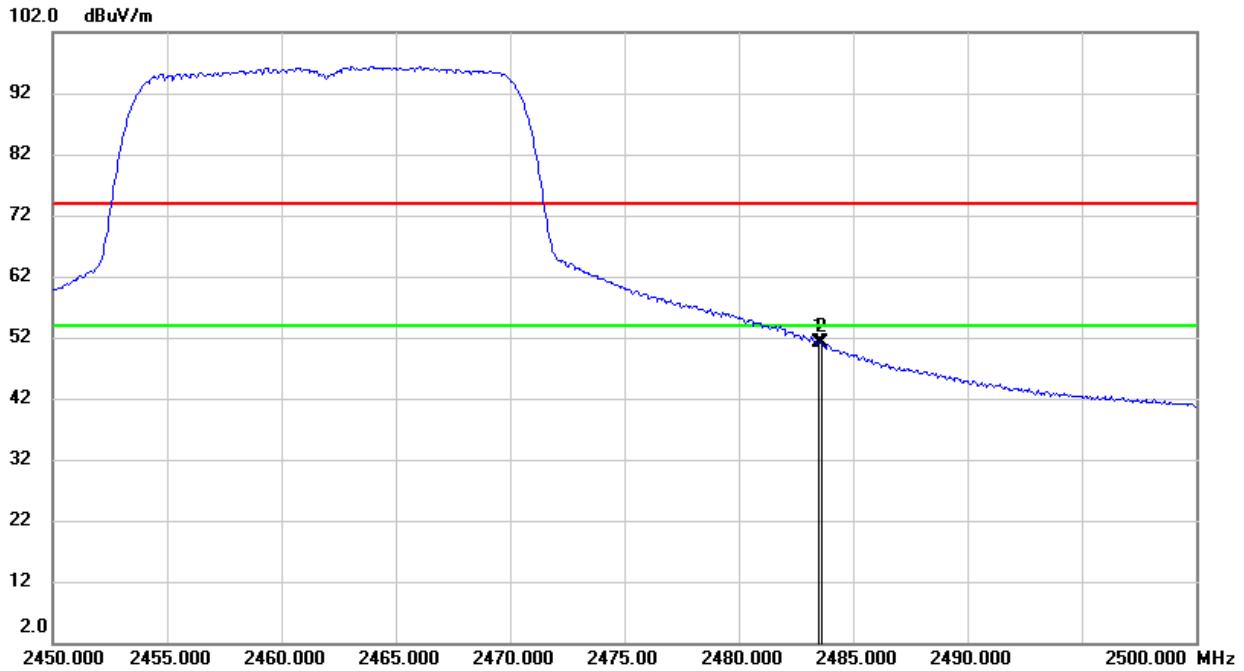

No.	Frequency (MHz)	Reading (dBuV)	Correct (dB/m)	Result (dBuV/m)	Limit (dBuV/m)	Margin (dB)	Remark
1	2483.500	18.94	32.31	51.25	54.00	-2.75	AVG
2	2483.650	18.90	32.31	51.21	54.00	-2.79	AVG

- Note: 1. Measurement = Reading Level + Correct Factor.
 2. If Peak Result complies with AV limit, AV Result is deemed to comply with AV limit.
 3. Peak: Peak detector.
 4. AVG: $VBW=1/Ton$, where: Ton is the transmitting duration.
 5. For the transmitting duration, please refer to clause 7.1.
 6. Only the worst case emission was recorded, if it complies with the limit, the other emissions deemed to comply with the limit.



8.1.3. 802.11n HT20 MODE

RESTRICTED BANDEDGE (CHANNEL 1, HORIZONTAL)

PEAK

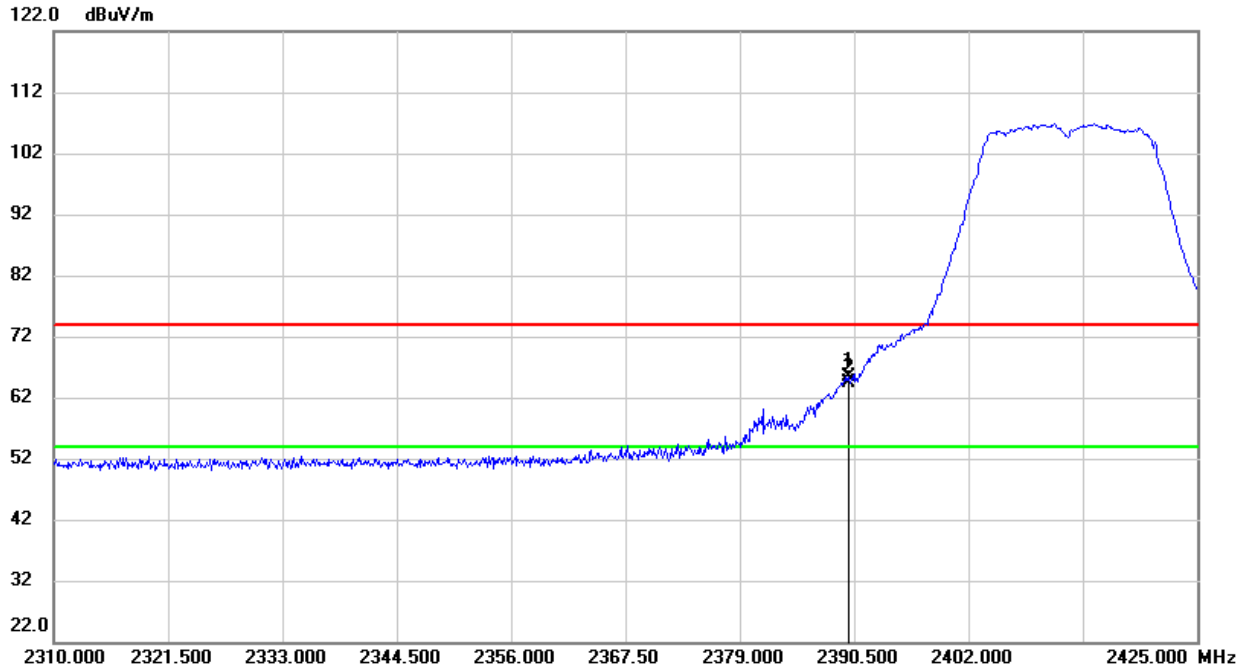

No.	Frequency (MHz)	Reading (dBuV)	Correct (dB/m)	Result (dBuV/m)	Limit (dBuV/m)	Margin (dB)	Remark
1	2389.925	33.34	32.10	65.44	74.00	-8.56	peak
2	2390.000	32.19	32.10	64.29	74.00	-9.71	peak

Note: 1. Measurement = Reading Level + Correct Factor.
 2. If Peak Result complies with AV limit, AV Result is deemed to comply with AV limit.
 3. Peak: Peak detector.
 4. Only the worst case emission was recorded, if it complies with the limit, the other emissions deemed to comply with the limit.



AVG

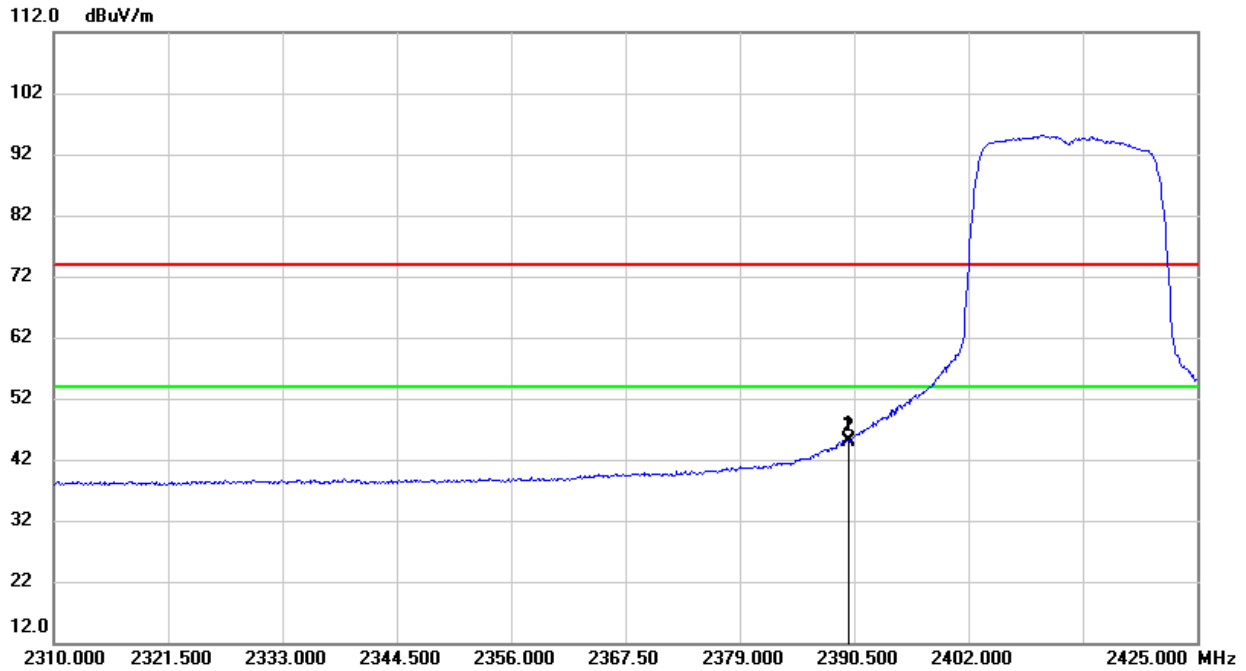

No.	Frequency (MHz)	Reading (dBuV)	Correct (dB/m)	Result (dBuV/m)	Limit (dBuV/m)	Margin (dB)	Remark
1	2389.925	12.92	32.10	45.02	54.00	-8.98	AVG
2	2390.000	12.72	32.10	44.82	54.00	-9.18	AVG

- Note:
1. Measurement = Reading Level + Correct Factor.
 2. If Peak Result complies with AV limit, AV Result is deemed to comply with AV limit.
 3. Peak: Peak detector.
 4. AVG: $VBW=1/Ton$, where: Ton is the transmitting duration.
 5. For the transmitting duration, please refer to clause 7.1.
 6. Only the worst case emission was recorded, if it complies with the limit, the other emissions deemed to comply with the limit.



RESTRICTED BANDEDGE (CHANNEL 1, VERTICAL)

PEAK

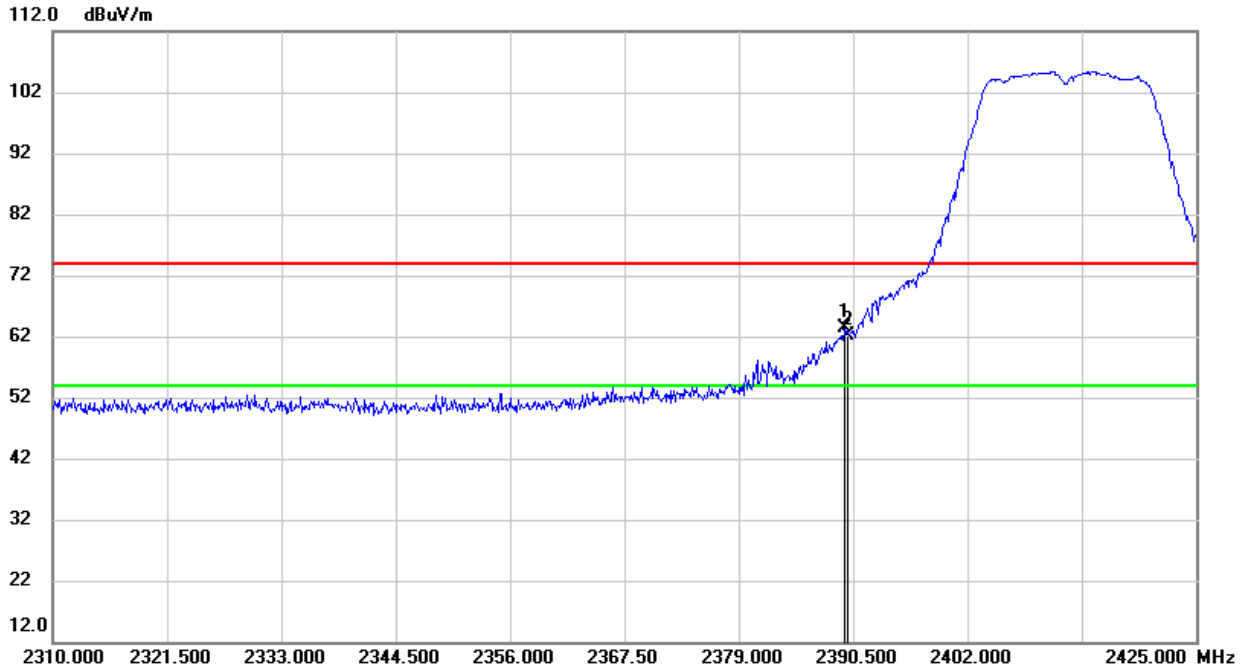

No.	Frequency (MHz)	Reading (dBuV)	Correct (dB/m)	Result (dBuV/m)	Limit (dBuV/m)	Margin (dB)	Remark
1	2389.695	31.33	32.10	63.43	74.00	-10.57	peak
2	2390.000	30.08	32.10	62.18	74.00	-11.82	peak

- Note: 1. Measurement = Reading Level + Correct Factor.
 2. If Peak Result complies with AV limit, AV Result is deemed to comply with AV limit.
 3. Peak: Peak detector.
 4. Only the worst case emission was recorded, if it complies with the limit, the other emissions deemed to comply with the limit.



AVG

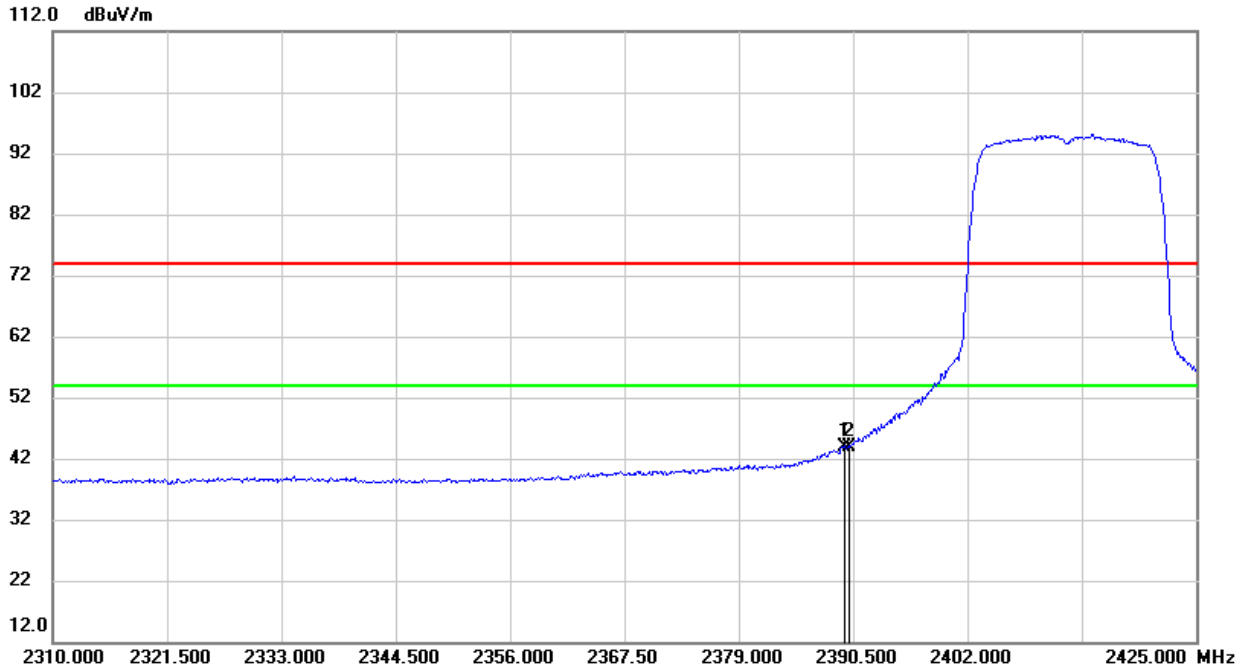

No.	Frequency (MHz)	Reading (dBuV)	Correct (dB/m)	Result (dBuV/m)	Limit (dBuV/m)	Margin (dB)	Remark
1	2389.695	11.84	32.10	43.94	54.00	-10.06	AVG
2	2390.000	11.76	32.10	43.86	54.00	-10.14	AVG

- Note:
1. Measurement = Reading Level + Correct Factor.
 2. If Peak Result complies with AV limit, AV Result is deemed to comply with AV limit.
 3. Peak: Peak detector.
 4. AVG: $VBW=1/T_{on}$, where: T_{on} is the transmitting duration.
 5. For the transmitting duration, please refer to clause 7.1.
 6. Only the worst case emission was recorded, if it complies with the limit, the other emissions deemed to comply with the limit.



RESTRICTED BANDEDGE (CHANNEL 2, HORIZONTAL)

PEAK

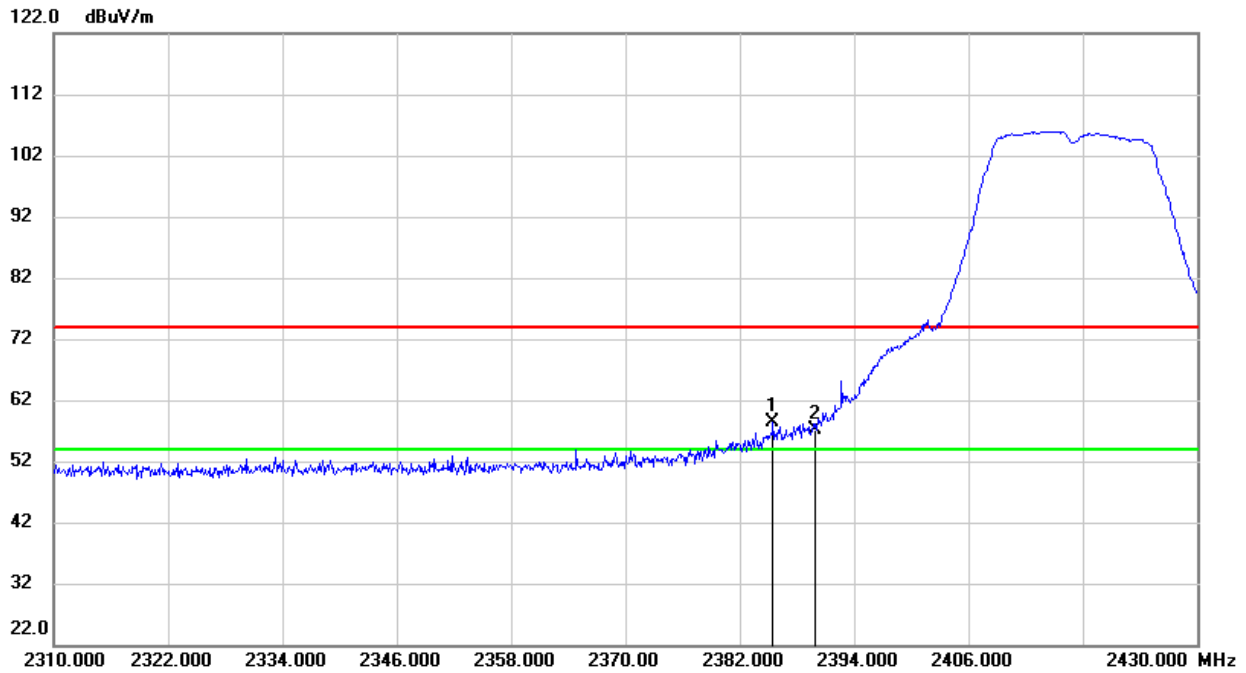

No.	Frequency (MHz)	Reading (dBuV)	Correct (dB/m)	Result (dBuV/m)	Limit (dBuV/m)	Margin (dB)	Remark
1	2385.480	26.36	32.09	58.45	74.00	-15.55	peak
2	2390.000	25.06	32.10	57.16	74.00	-16.84	peak

- Note: 1. Measurement = Reading Level + Correct Factor.
 2. If Peak Result complies with AV limit, AV Result is deemed to comply with AV limit.
 3. Peak: Peak detector.
 4. Only the worst case emission was recorded, if it complies with the limit, the other emissions deemed to comply with the limit.



AVG

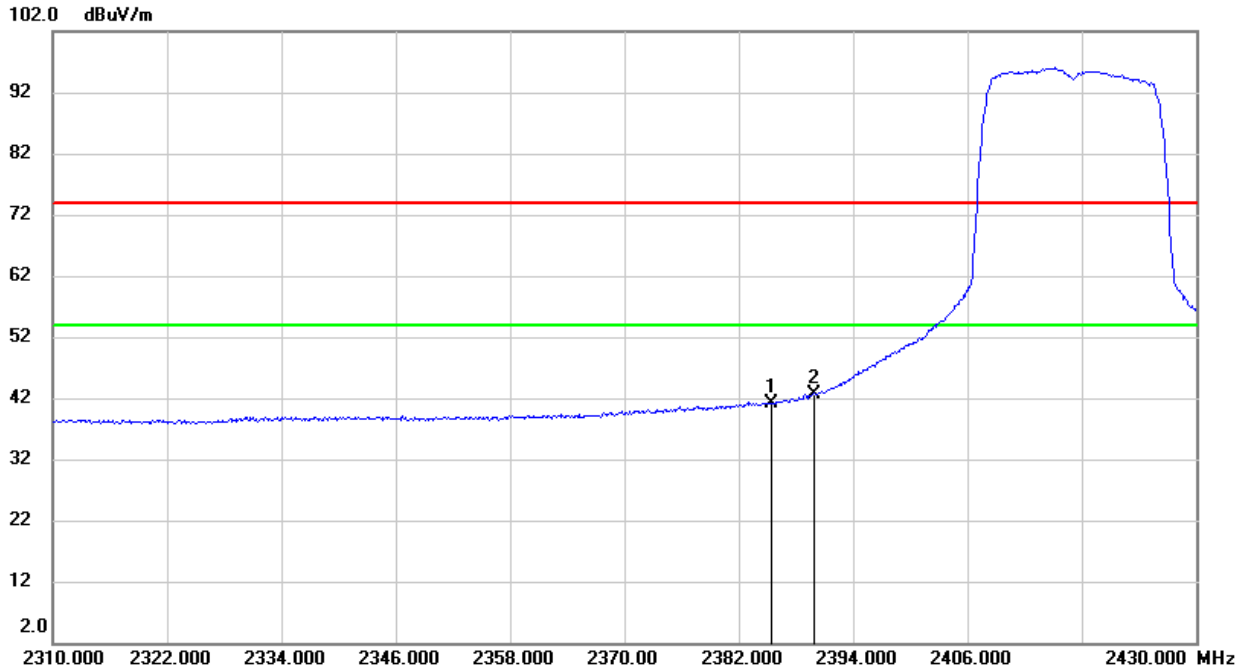

No.	Frequency (MHz)	Reading (dBuV)	Correct (dB/m)	Result (dBuV/m)	Limit (dBuV/m)	Margin (dB)	Remark
1	2385.480	9.01	32.09	41.10	54.00	-12.90	AVG
2	2390.000	10.44	32.10	42.54	54.00	-11.46	AVG

- Note:
1. Measurement = Reading Level + Correct Factor.
 2. If Peak Result complies with AV limit, AV Result is deemed to comply with AV limit.
 3. Peak: Peak detector.
 4. AVG: $VBW=1/T_{on}$, where: T_{on} is the transmitting duration.
 5. For the transmitting duration, please refer to clause 7.1.
 6. Only the worst case emission was recorded, if it complies with the limit, the other emissions deemed to comply with the limit.



RESTRICTED BANDEDGE (CHANNEL 2, VERTICAL)

PEAK

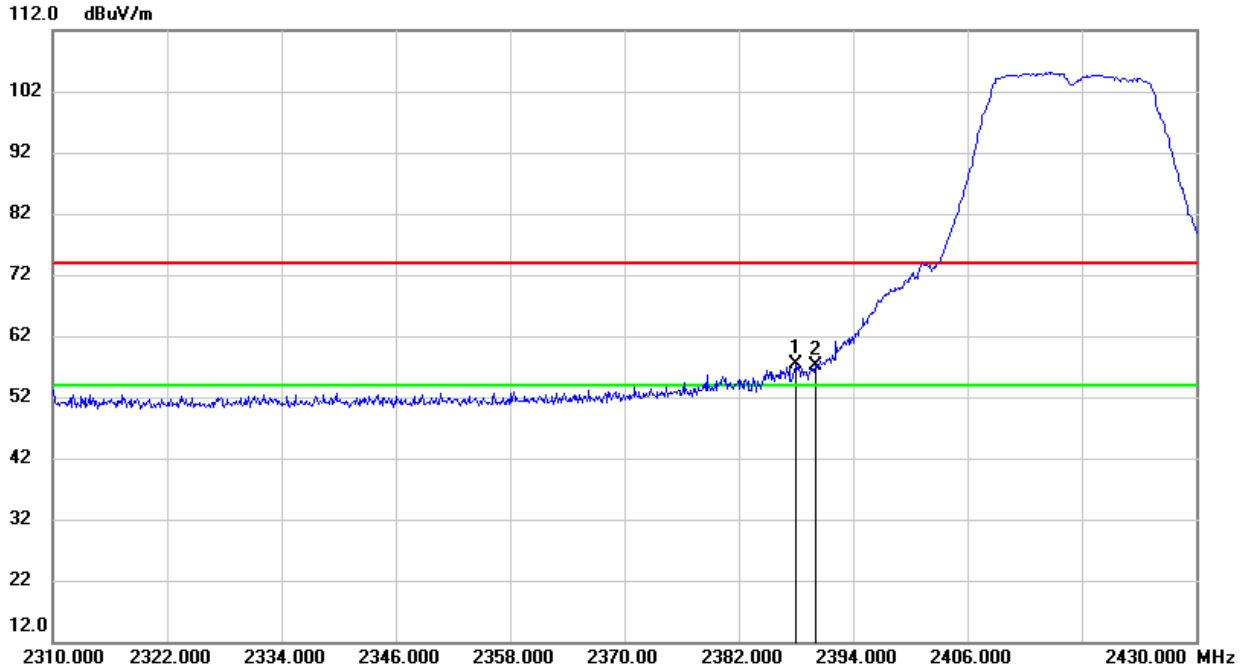

No.	Frequency (MHz)	Reading (dBuV)	Correct (dB/m)	Result (dBuV/m)	Limit (dBuV/m)	Margin (dB)	Remark
1	2388.000	25.19	32.10	57.29	74.00	-16.71	peak
2	2390.000	24.98	32.10	57.08	74.00	-16.92	peak

- Note:
1. Measurement = Reading Level + Correct Factor.
 2. If Peak Result complies with AV limit, AV Result is deemed to comply with AV limit.
 3. Peak: Peak detector.
 4. Only the worst case emission was recorded, if it complies with the limit, the other emissions deemed to comply with the limit.



AVG

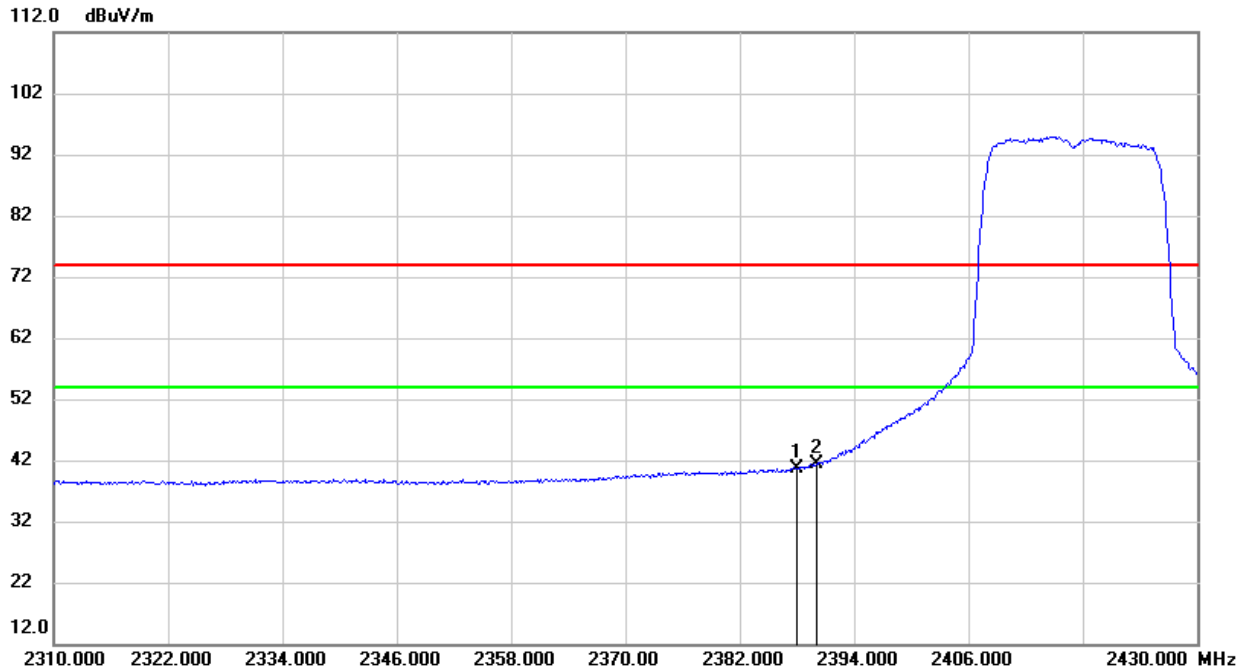

No.	Frequency (MHz)	Reading (dBuV)	Correct (dB/m)	Result (dBuV/m)	Limit (dBuV/m)	Margin (dB)	Remark
1	2388.000	8.62	32.10	40.72	54.00	-13.28	AVG
2	2390.000	9.21	32.10	41.31	54.00	-12.69	AVG

- Note:
1. Measurement = Reading Level + Correct Factor.
 2. If Peak Result complies with AV limit, AV Result is deemed to comply with AV limit.
 3. Peak: Peak detector.
 4. AVG: $VBW=1/T_{on}$, where: T_{on} is the transmitting duration.
 5. For the transmitting duration, please refer to clause 7.1.
 6. Only the worst case emission was recorded, if it complies with the limit, the other emissions deemed to comply with the limit.



RESTRICTED BANDEDGE (CHANNEL 10, HORIZONTAL)

PEAK

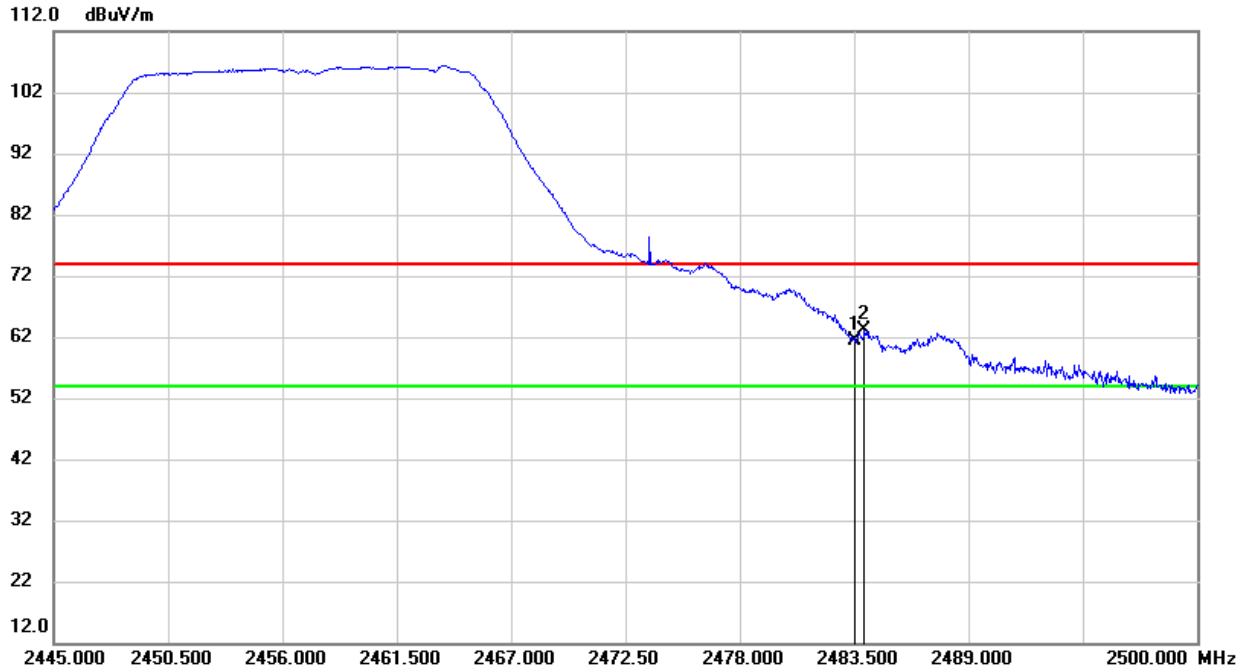

No.	Frequency (MHz)	Reading (dBuV)	Correct (dB/m)	Result (dBuV/m)	Limit (dBuV/m)	Margin (dB)	Remark
1	2483.500	29.15	32.31	61.46	74.00	-12.54	peak
2	2483.995	30.92	32.31	63.23	74.00	-10.77	peak

- Note: 1. Measurement = Reading Level + Correct Factor.
2. If Peak Result complies with AV limit, AV Result is deemed to comply with AV limit.
3. Peak: Peak detector.
4. Only the worst case emission was recorded, if it complies with the limit, the other emissions deemed to comply with the limit.



AVG

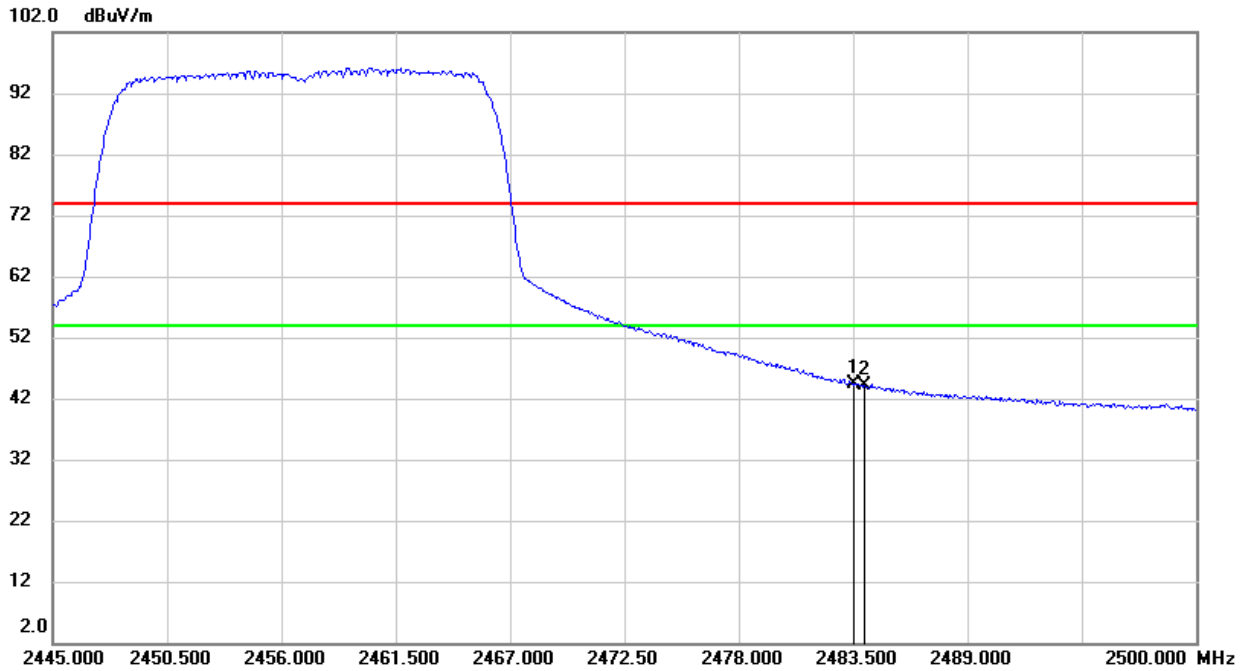

No.	Frequency (MHz)	Reading (dBuV)	Correct (dB/m)	Result (dBuV/m)	Limit (dBuV/m)	Margin (dB)	Remark
1	2483.500	11.99	32.31	44.30	54.00	-9.70	AVG
2	2483.995	11.91	32.31	44.22	54.00	-9.78	AVG

- Note: 1. Measurement = Reading Level + Correct Factor.
 2. If Peak Result complies with AV limit, AV Result is deemed to comply with AV limit.
 3. Peak: Peak detector.
 4. AVG: $VBW=1/T_{on}$, where: T_{on} is the transmitting duration.
 5. For the transmitting duration, please refer to clause 7.1.
 6. Only the worst case emission was recorded, if it complies with the limit, the other emissions deemed to comply with the limit.



RESTRICTED BANDEDGE (CHANNEL 10, VERTICAL)

PEAK

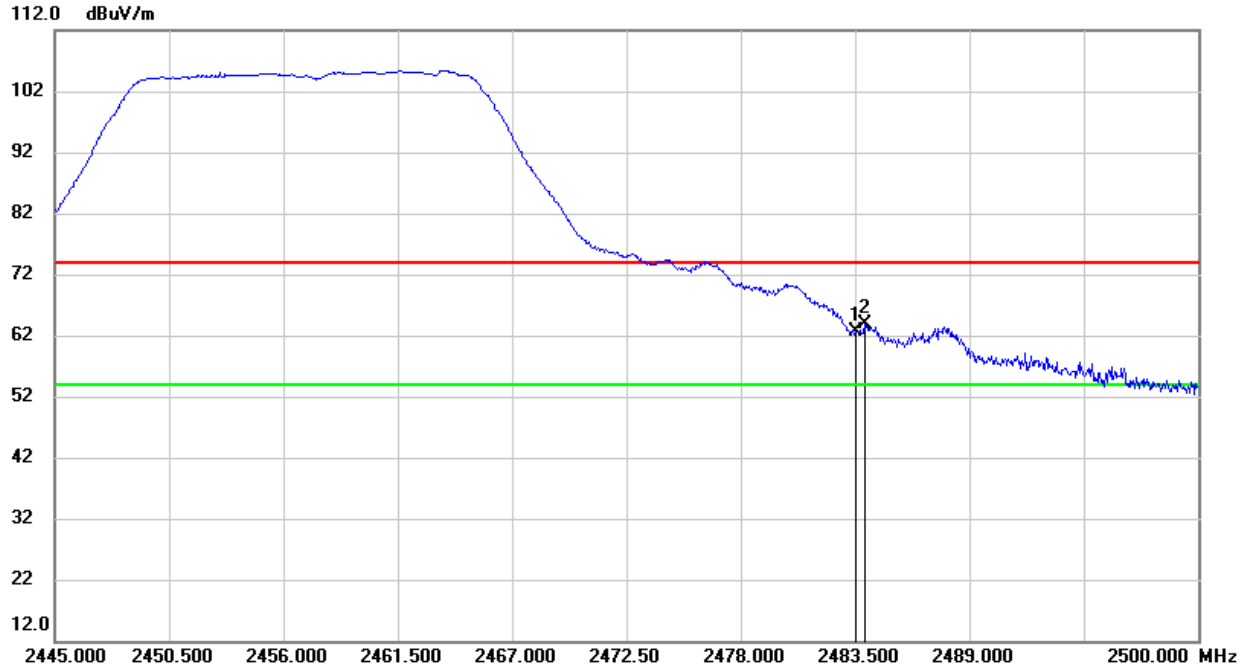

No.	Frequency (MHz)	Reading (dBuV)	Correct (dB/m)	Result (dBuV/m)	Limit (dBuV/m)	Margin (dB)	Remark
1	2483.500	30.35	32.31	62.66	74.00	-11.34	peak
2	2483.940	31.49	32.31	63.80	74.00	-10.20	peak

- Note: 1. Measurement = Reading Level + Correct Factor.
 2. If Peak Result complies with AV limit, AV Result is deemed to comply with AV limit.
 3. Peak: Peak detector.
 4. Only the worst case emission was recorded, if it complies with the limit, the other emissions deemed to comply with the limit.



AVG

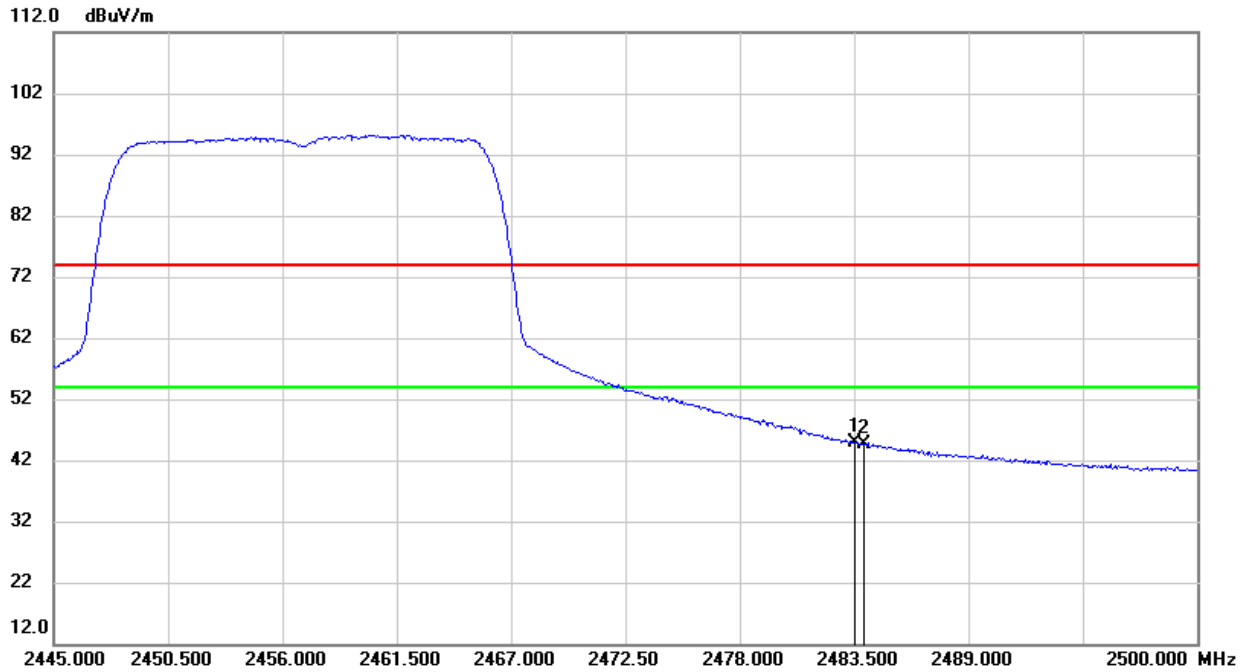

No.	Frequency (MHz)	Reading (dBuV)	Correct (dB/m)	Result (dBuV/m)	Limit (dBuV/m)	Margin (dB)	Remark
1	2483.500	12.57	32.31	44.88	54.00	-9.12	AVG
2	2483.940	12.35	32.31	44.66	54.00	-9.34	AVG

- Note:
1. Measurement = Reading Level + Correct Factor.
 2. If Peak Result complies with AV limit, AV Result is deemed to comply with AV limit.
 3. Peak: Peak detector.
 4. AVG: $VBW=1/T_{on}$, where: T_{on} is the transmitting duration.
 5. For the transmitting duration, please refer to clause 7.1.
 6. Only the worst case emission was recorded, if it complies with the limit, the other emissions deemed to comply with the limit.



RESTRICTED BANDEDGE (CHANNEL 11, HORIZONTAL)

PEAK

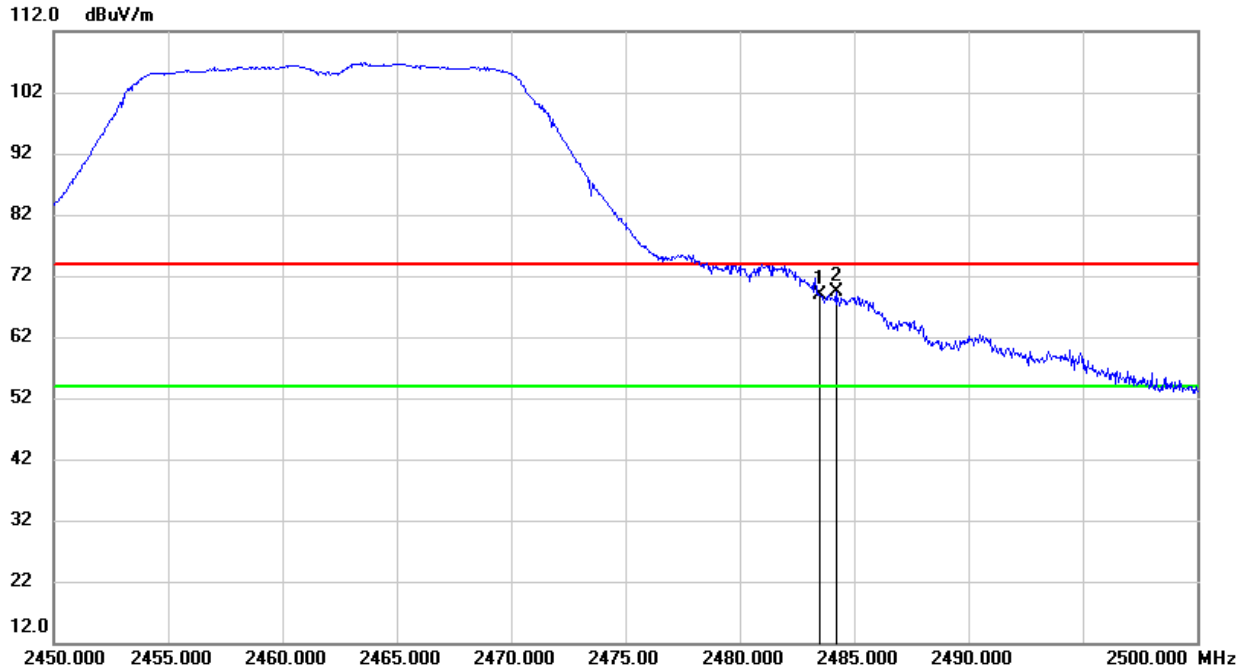

No.	Frequency (MHz)	Reading (dBuV)	Correct (dB/m)	Result (dBuV/m)	Limit (dBuV/m)	Margin (dB)	Remark
1	2483.500	36.45	32.31	68.76	74.00	-5.24	peak
2	2484.200	37.06	32.31	69.37	74.00	-4.63	peak

- Note: 1. Measurement = Reading Level + Correct Factor.
 2. If Peak Result complies with AV limit, AV Result is deemed to comply with AV limit.
 3. Peak: Peak detector.
 4. Only the worst case emission was recorded, if it complies with the limit, the other emissions deemed to comply with the limit.



AVG

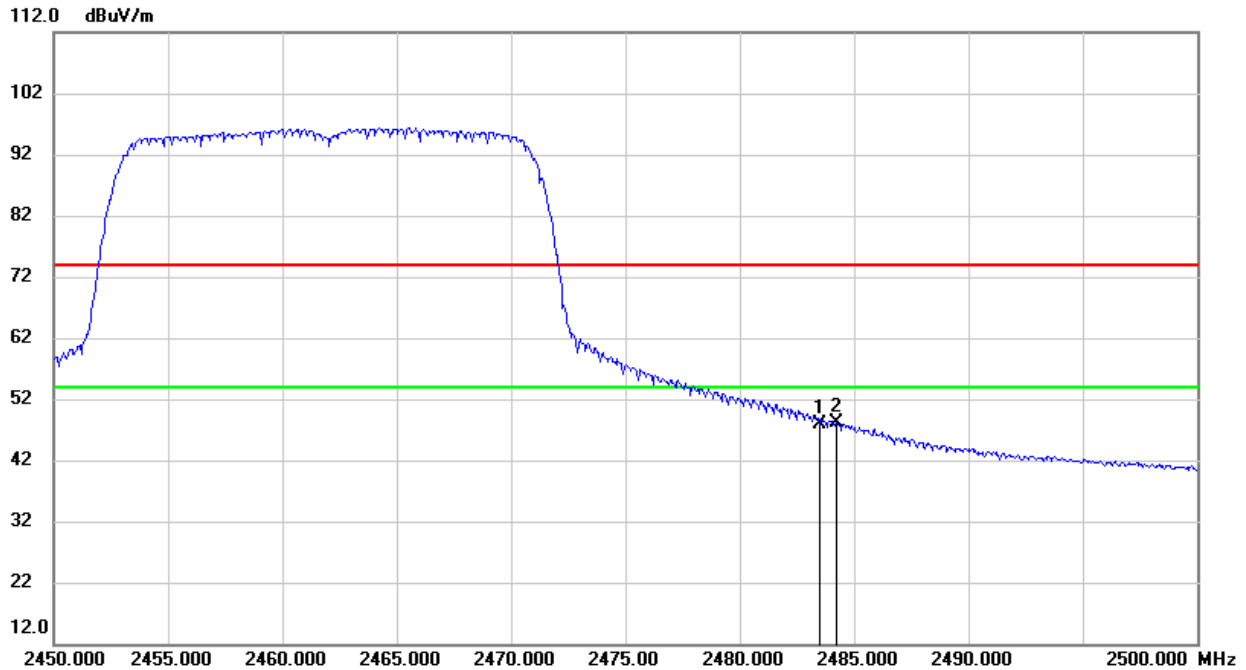

No.	Frequency (MHz)	Reading (dBuV)	Correct (dB/m)	Result (dBuV/m)	Limit (dBuV/m)	Margin (dB)	Remark
1	2483.500	15.57	32.31	47.88	54.00	-6.12	AVG
2	2484.200	15.85	32.31	48.16	54.00	-5.84	AVG

- Note: 1. Measurement = Reading Level + Correct Factor.
 2. If Peak Result complies with AV limit, AV Result is deemed to comply with AV limit.
 3. Peak: Peak detector.
 4. AVG: $VBW=1/Ton$, where: Ton is the transmitting duration.
 5. For the transmitting duration, please refer to clause 7.1.
 6. Only the worst case emission was recorded, if it complies with the limit, the other emissions deemed to comply with the limit.



RESTRICTED BANDEDGE (CHANNEL 11, VERTICAL)

PEAK

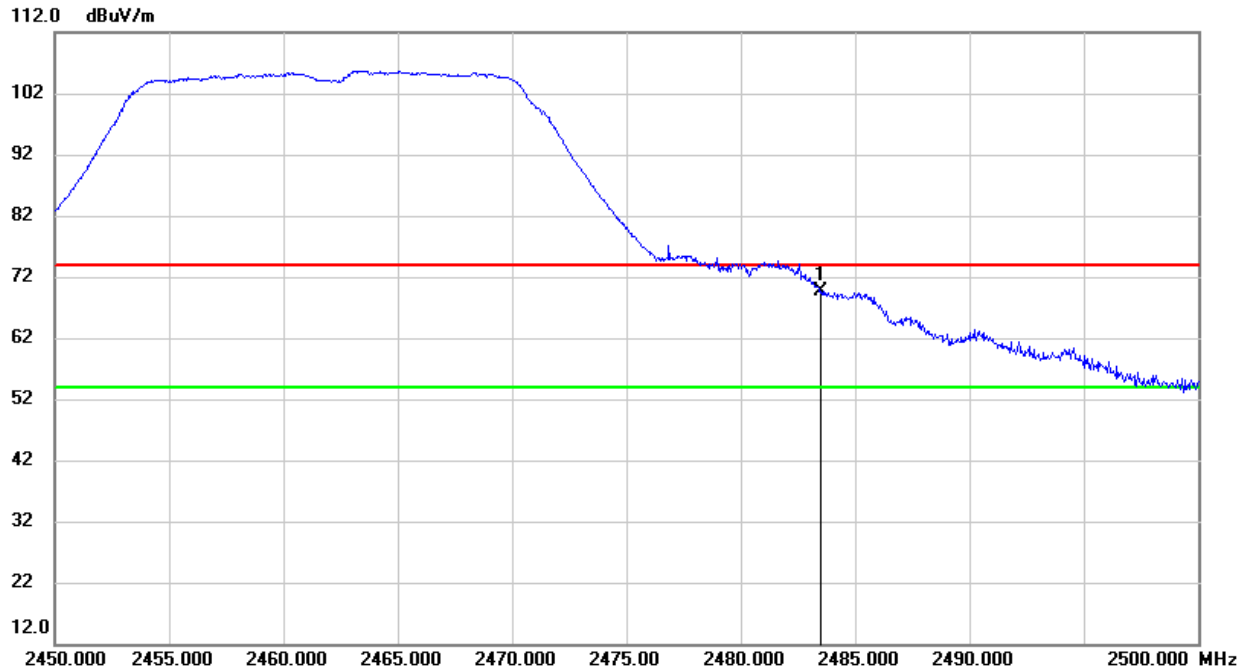

No.	Frequency (MHz)	Reading (dBuV)	Correct (dB/m)	Result (dBuV/m)	Limit (dBuV/m)	Margin (dB)	Remark
1	2483.500	37.29	32.31	69.60	74.00	-4.40	peak

- Note:
1. Measurement = Reading Level + Correct Factor.
 2. If Peak Result complies with AV limit, AV Result is deemed to comply with AV limit.
 3. Peak: Peak detector.
 4. Only the worst case emission was recorded, if it complies with the limit, the other emissions deemed to comply with the limit.



AVG

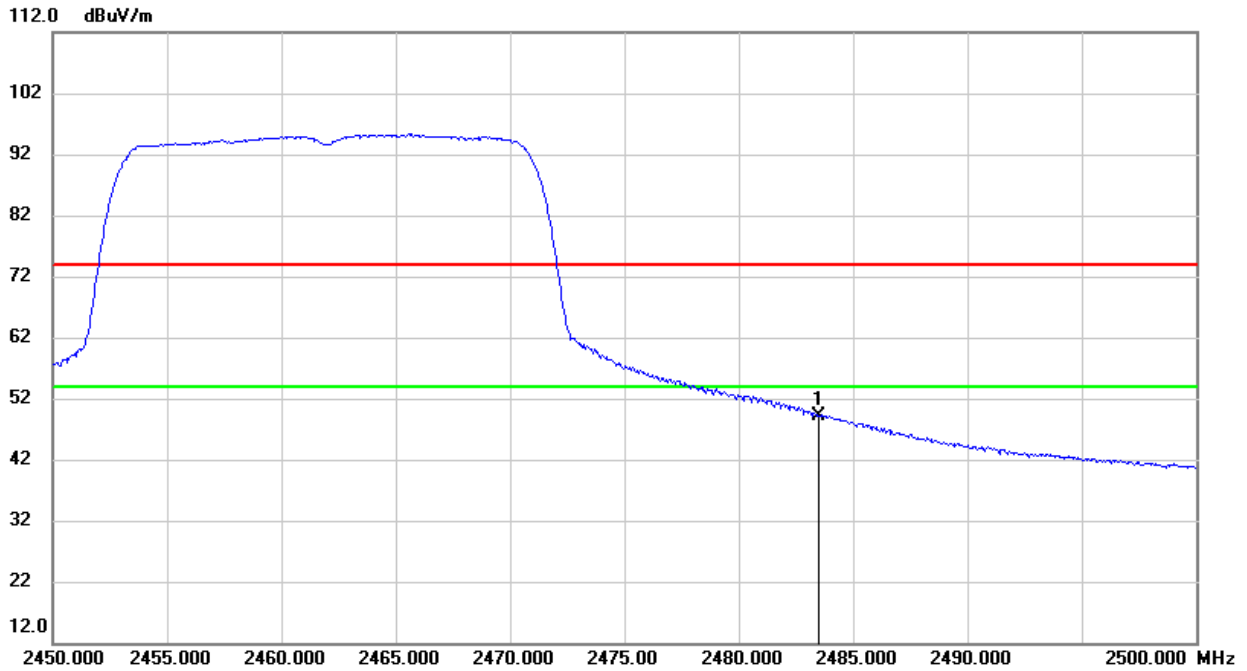

No.	Frequency (MHz)	Reading (dBuV)	Correct (dB/m)	Result (dBuV/m)	Limit (dBuV/m)	Margin (dB)	Remark
1	2483.500	16.74	32.31	49.05	54.00	-4.95	AVG

- Note:
1. Measurement = Reading Level + Correct Factor.
 2. If Peak Result complies with AV limit, AV Result is deemed to comply with AV limit.
 3. Peak: Peak detector.
 4. AVG: $VBW=1/Ton$, where: Ton is the transmitting duration.
 5. For the transmitting duration, please refer to clause 7.1.
 6. Only the worst case emission was recorded, if it complies with the limit, the other emissions deemed to comply with the limit.



8.2. SPURIOUS EMISSIONS (3~18GHz)

8.2.1. 802.11b MODE

HARMONICS AND SPURIOUS EMISSIONS (CHANNEL 1, HORIZONTAL)

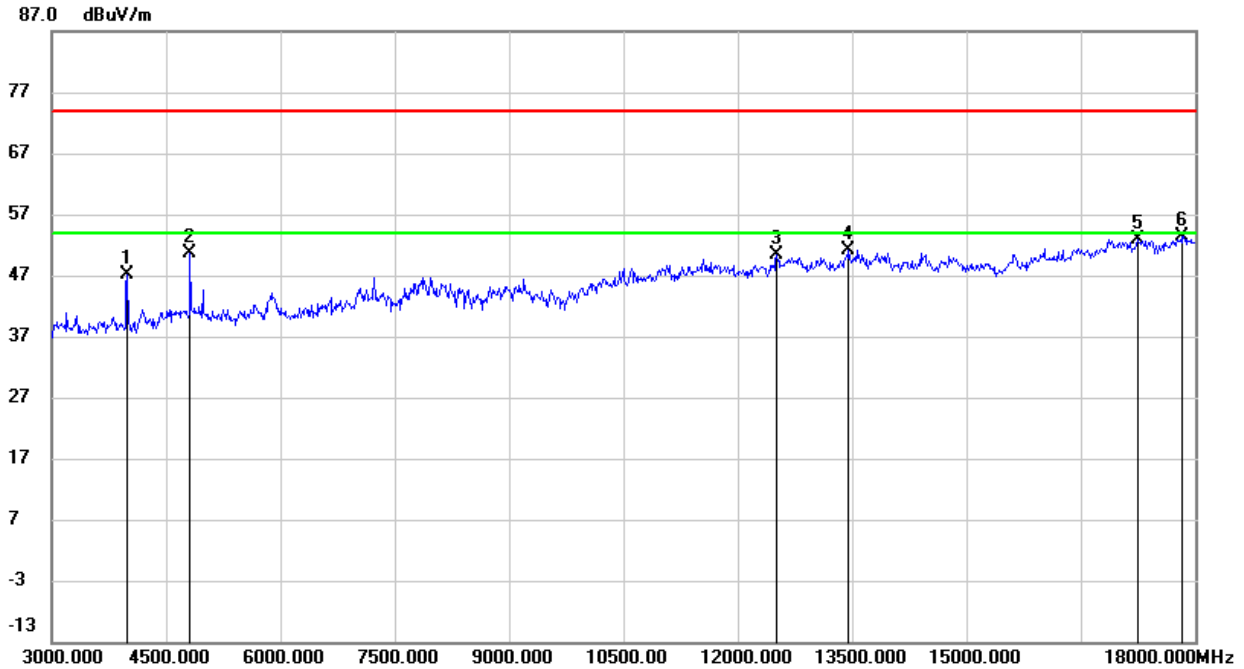

No.	Frequency (MHz)	Reading (dBuV)	Correct (dB/m)	Result (dBuV/m)	Limit (dBuV/m)	Margin (dB)	Remark
1	3990.000	49.94	-2.89	47.05	74.00	-26.95	peak
2	4815.000	50.02	0.51	50.53	74.00	-23.47	peak
3	12510.000	35.91	14.51	50.42	74.00	-23.58	peak
4	13455.000	35.30	15.93	51.23	74.00	-22.77	peak
5	17250.000	31.64	21.33	52.97	74.00	-21.03	peak
6	17820.000	30.19	23.30	53.49	74.00	-20.51	peak

- Note: 1. Measurement = Reading Level + Correct Factor.
 2. If Peak Result complies with AV limit, AV Result is deemed to comply with AV limit.
 3. Peak: Peak detector.
 4. Filter losses were only considered in the spurious frequency bands and the authorized band was not corrected for High Pass Filter losses.
 5. Proper operation of the transmitter prior to adding the filter to the measurement chain.



HARMONICS AND SPURIOUS EMISSIONS (CHANNEL 1, VERTICAL)

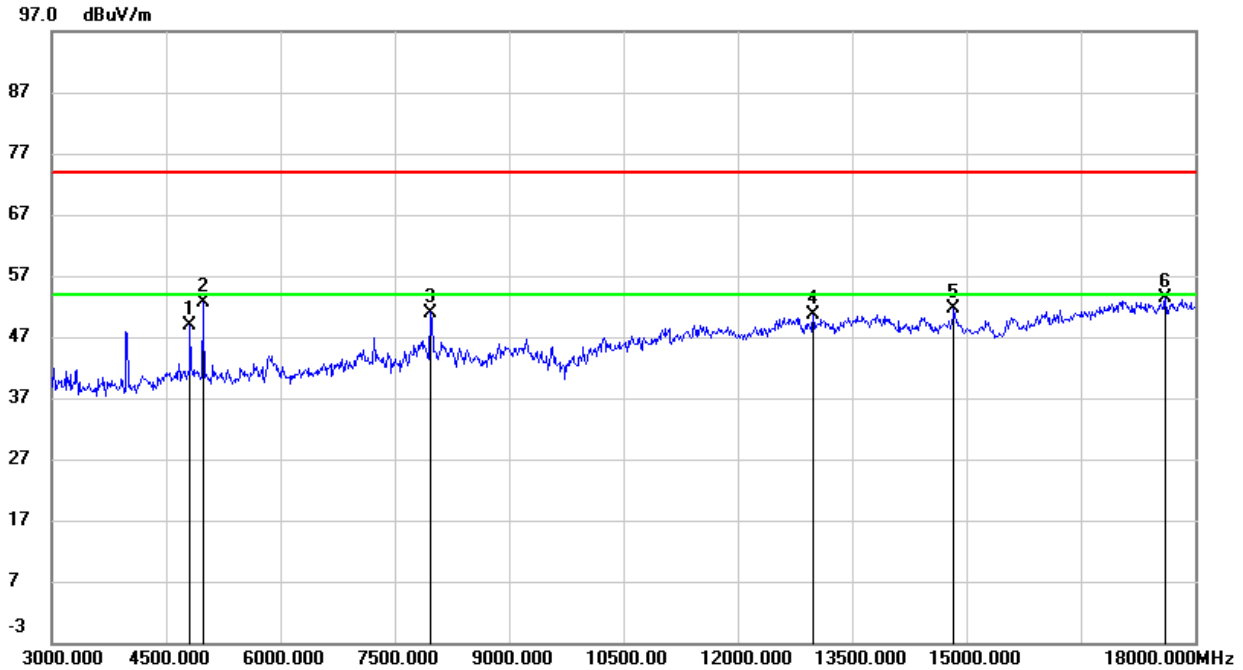

No.	Frequency (MHz)	Reading (dBuV)	Correct (dB/m)	Result (dBuV/m)	Limit (dBuV/m)	Margin (dB)	Remark
1	4815.000	48.27	0.51	48.78	74.00	-25.22	peak
2	4980.000	51.25	1.29	52.54	74.00	-21.46	peak
3	7965.000	44.00	7.00	51.00	74.00	-23.00	peak
4	12990.000	35.59	14.92	50.51	74.00	-23.49	peak
5	14835.000	35.72	15.95	51.67	74.00	-22.33	peak
6	17610.000	31.62	21.86	53.48	74.00	-20.52	peak

- Note: 1. Measurement = Reading Level + Correct Factor.
 2. If Peak Result complies with AV limit, AV Result is deemed to comply with AV limit.
 3. Peak: Peak detector.
 4. Filter losses were only considered in the spurious frequency bands and the authorized band was not corrected for High Pass Filter losses.
 5. Proper operation of the transmitter prior to adding the filter to the measurement chain.



HARMONICS AND SPURIOUS EMISSIONS (CHANNEL 2, HORIZONTAL)

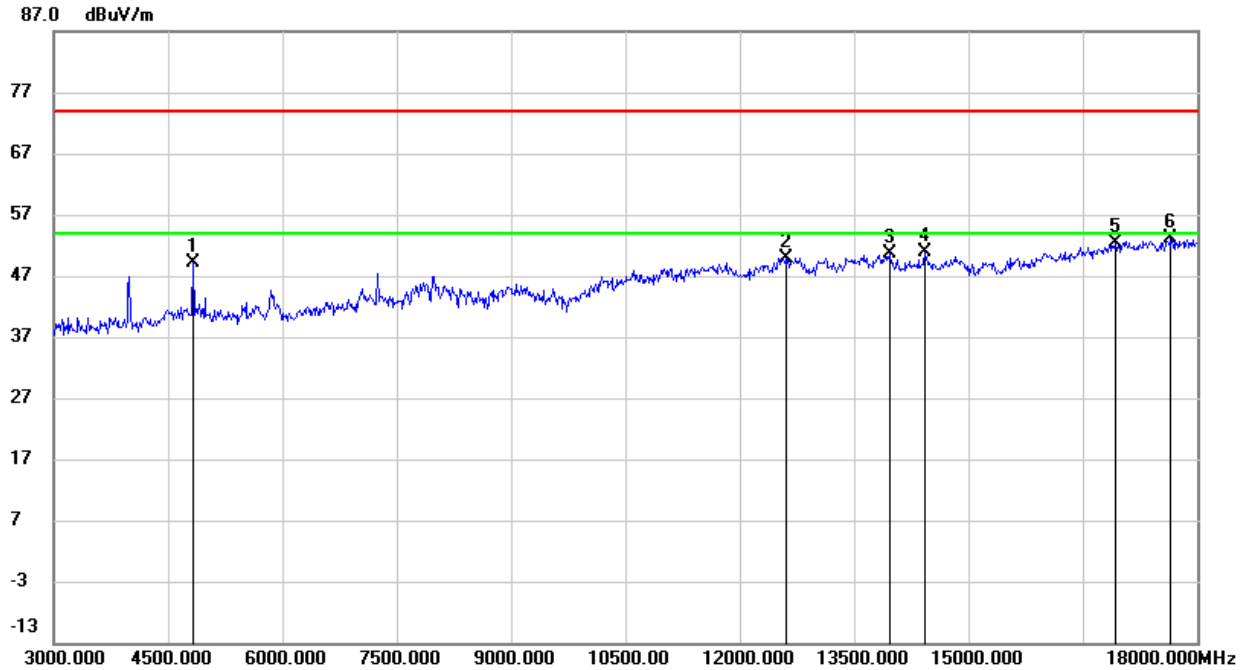

No.	Frequency (MHz)	Reading (dBuV)	Correct (dB/m)	Result (dBuV/m)	Limit (dBuV/m)	Margin (dB)	Remark
1	4830.000	48.59	0.59	49.18	74.00	-24.82	peak
2	12600.000	35.95	13.99	49.94	74.00	-24.06	peak
3	13965.000	34.43	16.09	50.52	74.00	-23.48	peak
4	14430.000	34.60	16.35	50.95	74.00	-23.05	peak
5	16935.000	32.21	20.12	52.33	74.00	-21.67	peak
6	17655.000	30.96	22.15	53.11	74.00	-20.89	peak

- Note: 1. Measurement = Reading Level + Correct Factor.
 2. If Peak Result complies with AV limit, AV Result is deemed to comply with AV limit.
 3. Peak: Peak detector.
 4. Filter losses were only considered in the spurious frequency bands and the authorized band was not corrected for High Pass Filter losses.
 5. Proper operation of the transmitter prior to adding the filter to the measurement chain.



HARMONICS AND SPURIOUS EMISSIONS (CHANNEL 2, VERTICAL)

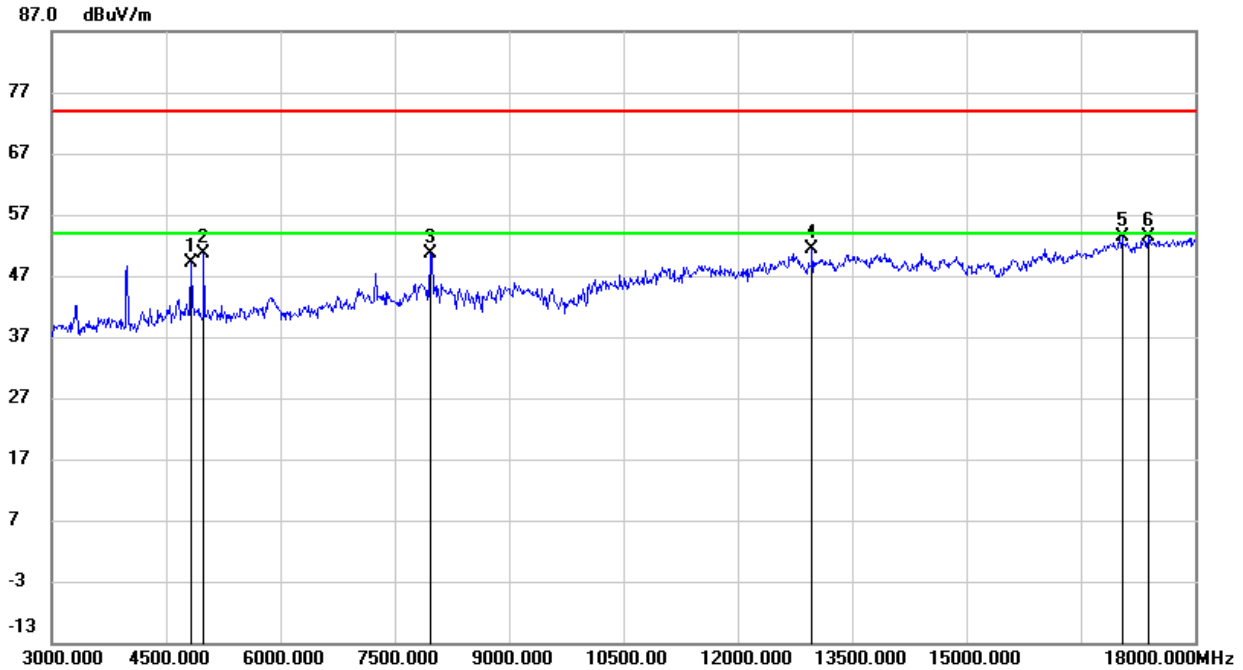

No.	Frequency (MHz)	Reading (dBuV)	Correct (dB/m)	Result (dBuV/m)	Limit (dBuV/m)	Margin (dB)	Remark
1	4830.000	48.49	0.59	49.08	74.00	-24.92	peak
2	4995.000	49.30	1.37	50.67	74.00	-23.33	peak
3	7965.000	43.58	7.00	50.58	74.00	-23.42	peak
4	12975.000	36.42	14.93	51.35	74.00	-22.65	peak
5	17040.000	32.93	20.49	53.42	74.00	-20.58	peak
6	17385.000	31.83	21.46	53.29	74.00	-20.71	peak

- Note: 1. Measurement = Reading Level + Correct Factor.
 2. If Peak Result complies with AV limit, AV Result is deemed to comply with AV limit.
 3. Peak: Peak detector.
 4. Filter losses were only considered in the spurious frequency bands and the authorized band was not corrected for High Pass Filter losses.
 5. Proper operation of the transmitter prior to adding the filter to the measurement chain.



HARMONICS AND SPURIOUS EMISSIONS (CHANNEL 6, HORIZONTAL)

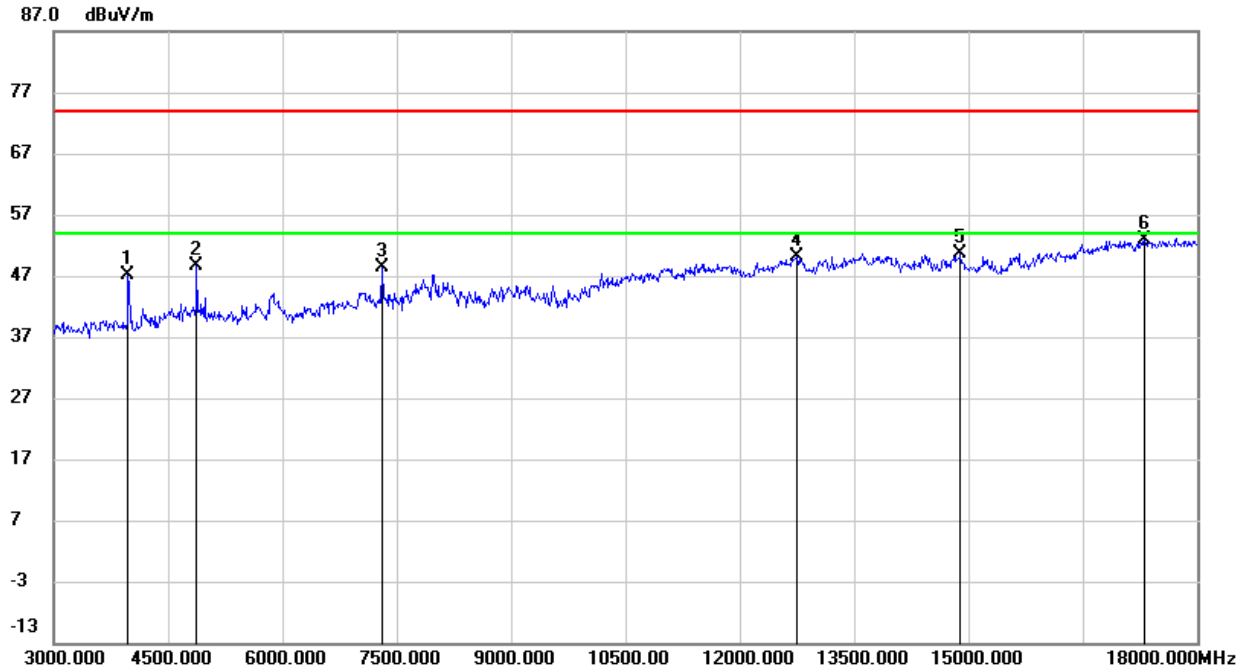

No.	Frequency (MHz)	Reading (dBuV)	Correct (dB/m)	Result (dBuV/m)	Limit (dBuV/m)	Margin (dB)	Remark
1	3975.000	49.92	-2.90	47.02	74.00	-26.98	peak
2	4875.000	47.75	0.76	48.51	74.00	-25.49	peak
3	7305.000	42.19	6.08	48.27	74.00	-25.73	peak
4	12750.000	35.21	14.98	50.19	74.00	-23.81	peak
5	14895.000	34.59	16.01	50.60	74.00	-23.40	peak
6	17310.000	31.24	21.72	52.96	74.00	-21.04	peak

- Note: 1. Measurement = Reading Level + Correct Factor.
 2. If Peak Result complies with AV limit, AV Result is deemed to comply with AV limit.
 3. Peak: Peak detector.
 4. Filter losses were only considered in the spurious frequency bands and the authorized band was not corrected for High Pass Filter losses.
 5. Proper operation of the transmitter prior to adding the filter to the measurement chain.



HARMONICS AND SPURIOUS EMISSIONS (CHANNEL 6, VERTICAL)

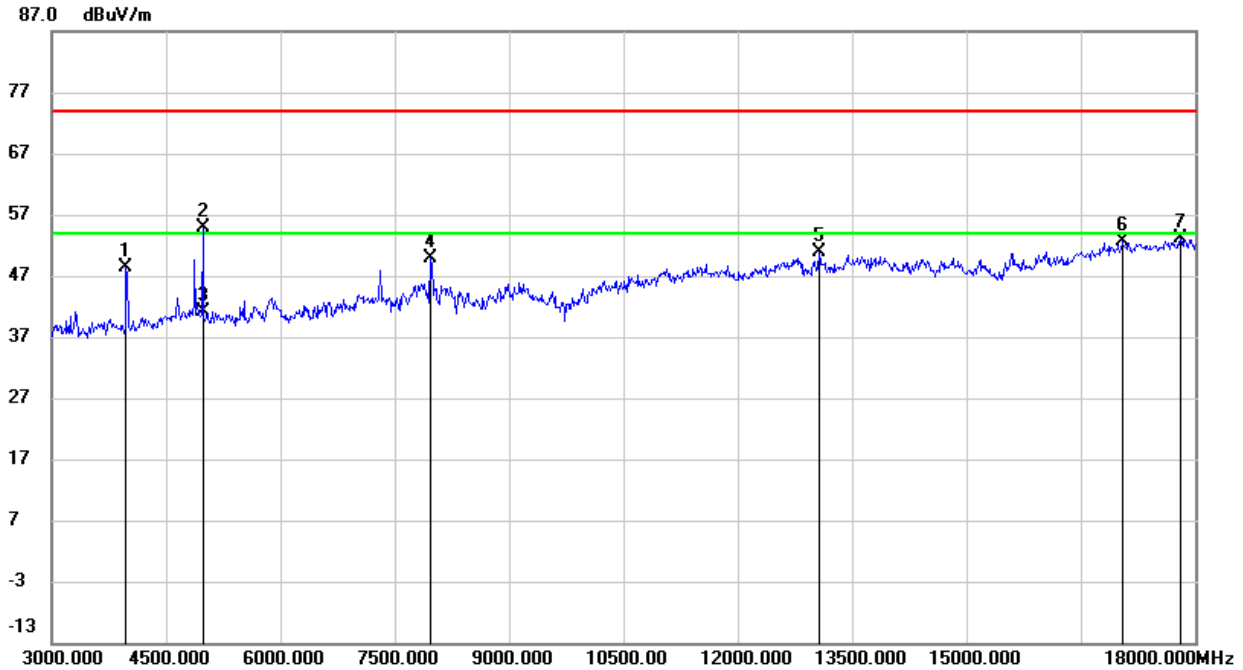

No.	Frequency (MHz)	Reading (dBuV)	Correct (dB/m)	Result (dBuV/m)	Limit (dBuV/m)	Margin (dB)	Remark
1	3975.000	51.17	-2.90	48.27	74.00	-25.73	peak
2	4980.000	53.70	1.29	54.99	74.00	-19.01	peak
3	4980.000	39.82	1.29	41.11	54.00	-12.89	AVG
4	7965.000	42.79	7.00	49.79	74.00	-24.21	peak
5	13065.000	35.88	15.11	50.99	74.00	-23.01	peak
6	17040.000	32.04	20.49	52.53	74.00	-21.47	peak
7	17805.000	29.78	23.31	53.09	74.00	-20.91	peak

- Note: 1. Measurement = Reading Level + Correct Factor.
 2. If Peak Result complies with AV limit, AV Result is deemed to comply with AV limit.
 3. Peak: Peak detector.
 4. Filter losses were only considered in the spurious frequency bands and the authorized band was not corrected for High Pass Filter losses.
 5. Proper operation of the transmitter prior to adding the filter to the measurement chain.



HARMONICS AND SPURIOUS EMISSIONS (CHANNEL 10, HORIZONTAL)

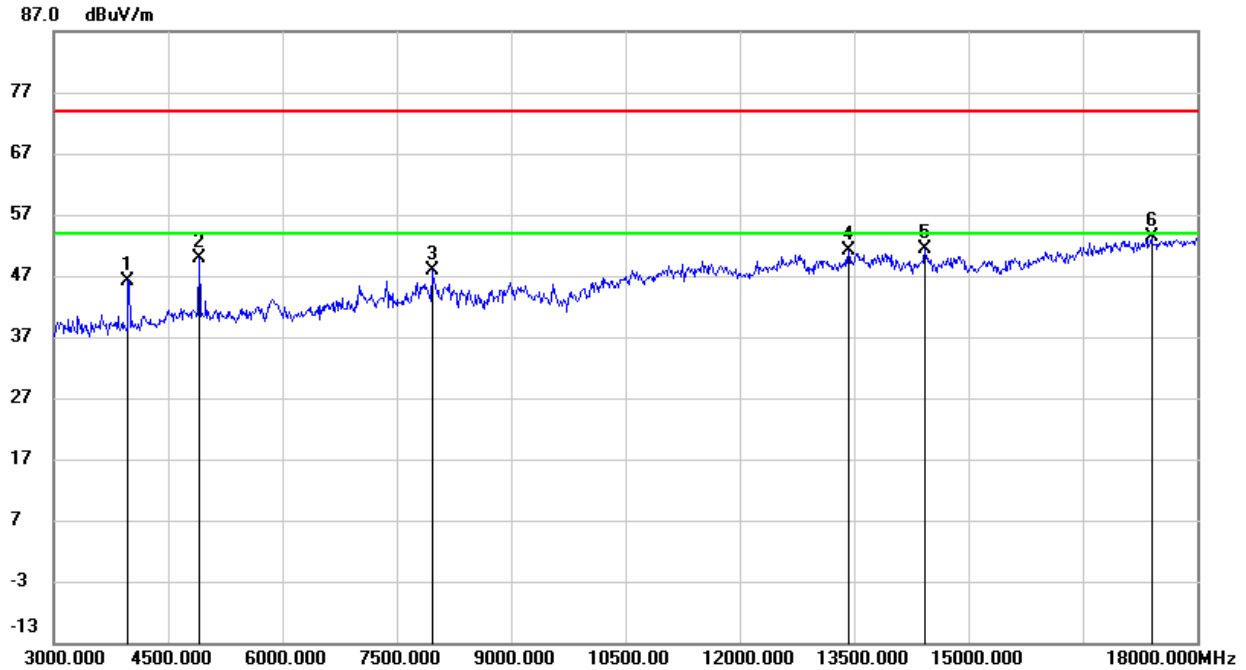

No.	Frequency (MHz)	Reading (dBuV)	Correct (dB/m)	Result (dBuV/m)	Limit (dBuV/m)	Margin (dB)	Remark
1	3975.000	49.12	-2.90	46.22	74.00	-27.78	peak
2	4905.000	49.01	0.88	49.89	74.00	-24.11	peak
3	7965.000	40.95	7.00	47.95	74.00	-26.05	peak
4	13425.000	35.09	16.02	51.11	74.00	-22.89	peak
5	14430.000	34.99	16.35	51.34	74.00	-22.66	peak
6	17400.000	32.07	21.41	53.48	74.00	-20.52	peak

- Note: 1. Measurement = Reading Level + Correct Factor.
 2. If Peak Result complies with AV limit, AV Result is deemed to comply with AV limit.
 3. Peak: Peak detector.
 4. Filter losses were only considered in the spurious frequency bands and the authorized band was not corrected for High Pass Filter losses.
 5. Proper operation of the transmitter prior to adding the filter to the measurement chain.



HARMONICS AND SPURIOUS EMISSIONS (CHANNEL 10, VERTICAL)

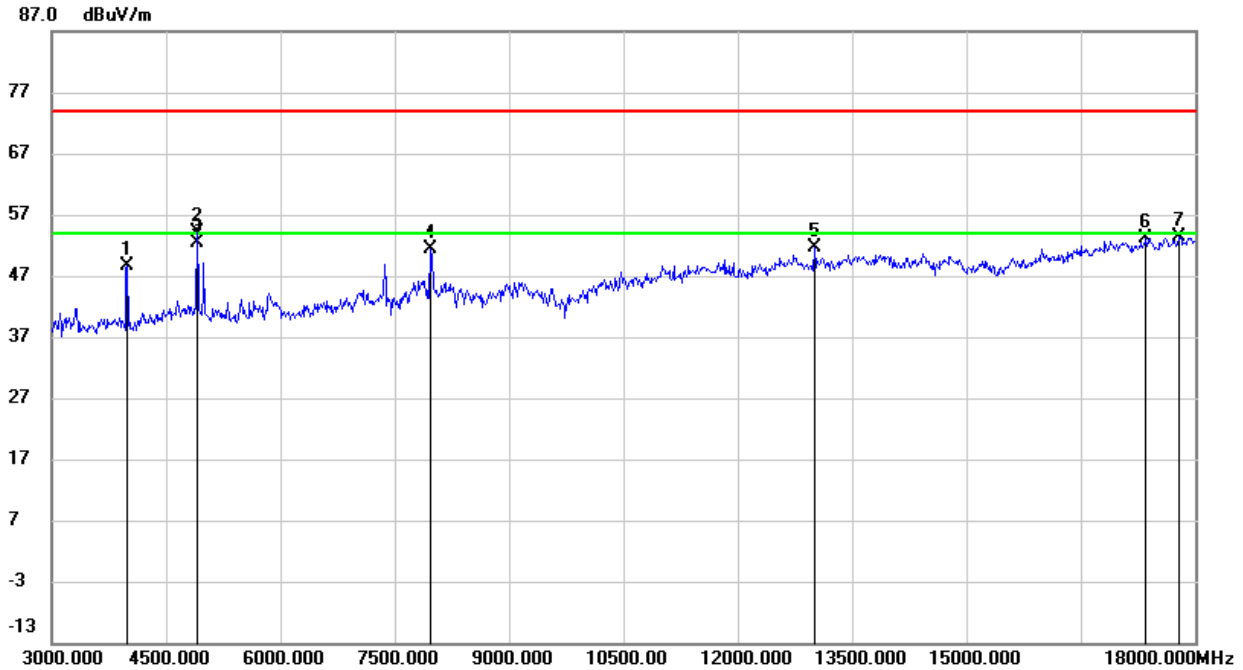

No.	Frequency (MHz)	Reading (dBuV)	Correct (dB/m)	Result (dBuV/m)	Limit (dBuV/m)	Margin (dB)	Remark
1	3990.000	51.41	-2.89	48.52	74.00	-25.48	peak
2	4905.000	53.22	0.88	54.10	74.00	-19.90	peak
3	4905.000	51.45	0.88	52.33	54.00	-1.67	AVG
4	7965.000	44.34	7.00	51.34	74.00	-22.66	peak
5	13005.000	36.59	14.95	51.54	74.00	-22.46	peak
6	17355.000	31.56	21.56	53.12	74.00	-20.88	peak
7	17790.000	30.06	23.22	53.28	74.00	-20.72	peak

- Note: 1. Measurement = Reading Level + Correct Factor.
 2. If Peak Result complies with AV limit, AV Result is deemed to comply with AV limit.
 3. Peak: Peak detector.
 4. Filter losses were only considered in the spurious frequency bands and the authorized band was not corrected for High Pass Filter losses.
 5. Proper operation of the transmitter prior to adding the filter to the measurement chain.



HARMONICS AND SPURIOUS EMISSIONS (CHANNEL 11, HORIZONTAL)

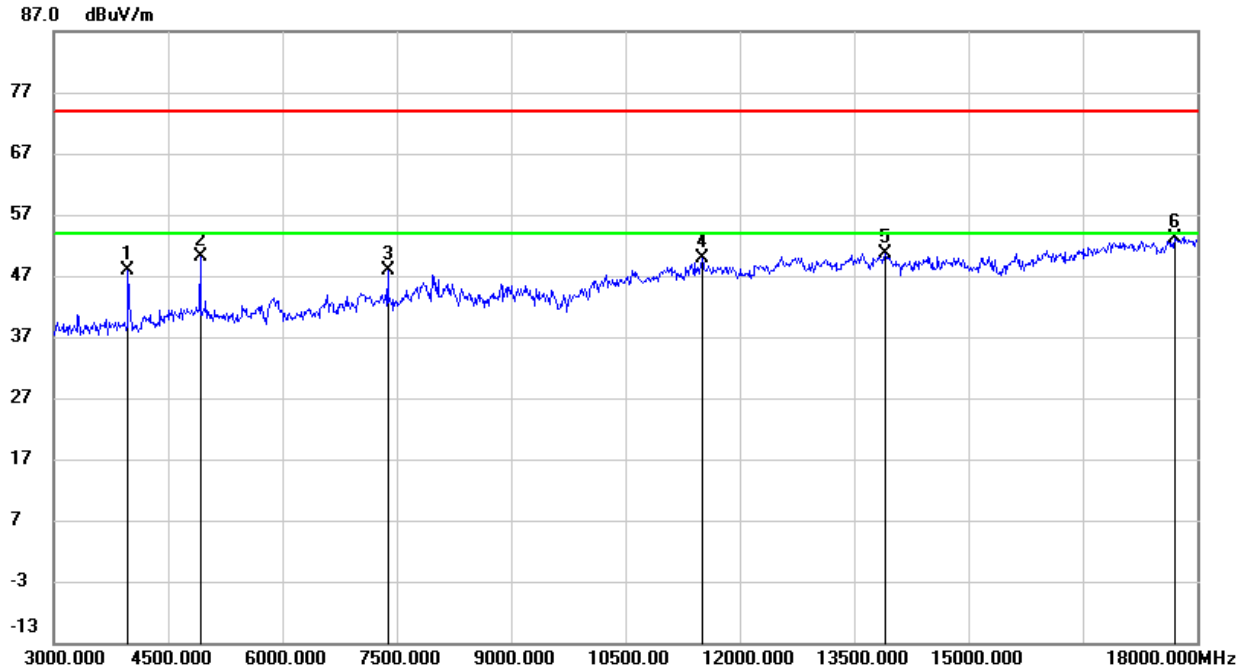

No.	Frequency (MHz)	Reading (dBuV)	Correct (dB/m)	Result (dBuV/m)	Limit (dBuV/m)	Margin (dB)	Remark
1	3975.000	50.76	-2.90	47.86	74.00	-26.14	peak
2	4920.000	49.15	0.96	50.11	74.00	-23.89	peak
3	7380.000	41.53	6.41	47.94	74.00	-26.06	peak
4	11505.000	36.42	13.42	49.84	74.00	-24.16	peak
5	13905.000	34.42	16.20	50.62	74.00	-23.38	peak
6	17700.000	30.62	22.43	53.05	74.00	-20.95	peak

- Note: 1. Measurement = Reading Level + Correct Factor.
2. If Peak Result complies with AV limit, AV Result is deemed to comply with AV limit.
3. Peak: Peak detector.
4. Filter losses were only considered in the spurious frequency bands and the authorized band was not corrected for High Pass Filter losses.
5. Proper operation of the transmitter prior to adding the filter to the measurement chain.



HARMONICS AND SPURIOUS EMISSIONS (CHANNEL 11, VERTICAL)

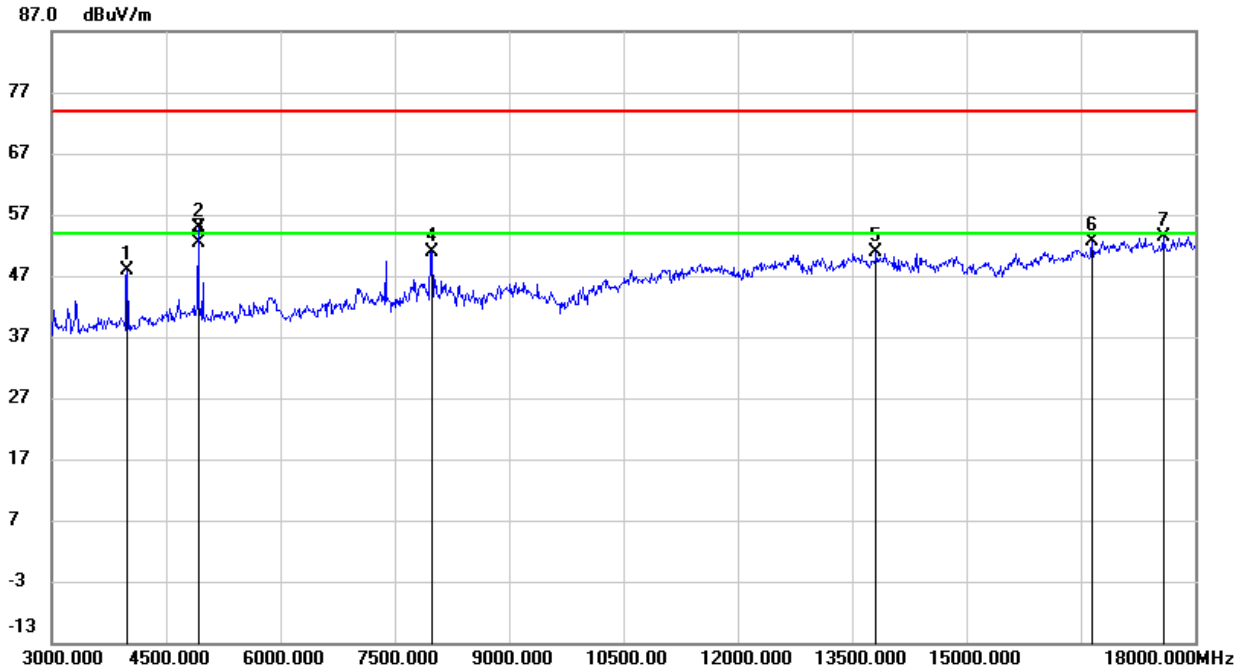

No.	Frequency (MHz)	Reading (dBuV)	Correct (dB/m)	Result (dBuV/m)	Limit (dBuV/m)	Margin (dB)	Remark
1	3990.000	50.81	-2.89	47.92	74.00	-26.08	peak
2	4920.000	53.97	0.96	54.93	74.00	-19.07	peak
3	4920.000	51.31	0.96	52.27	54.00	-1.73	AVG
4	7995.000	44.09	6.89	50.98	74.00	-23.02	peak
5	13815.000	33.96	16.97	50.93	74.00	-23.07	peak
6	16650.000	33.04	19.70	52.74	74.00	-21.26	peak
7	17580.000	31.73	21.71	53.44	74.00	-20.56	peak

- Note: 1. Measurement = Reading Level + Correct Factor.
 2. If Peak Result complies with AV limit, AV Result is deemed to comply with AV limit.
 3. Peak: Peak detector.
 4. Filter losses were only considered in the spurious frequency bands and the authorized band was not corrected for High Pass Filter losses.
 5. Proper operation of the transmitter prior to adding the filter to the measurement chain.



8.2.2. 802.11g MODE

HARMONICS AND SPURIOUS EMISSIONS (CHANNEL 1, HORIZONTAL)

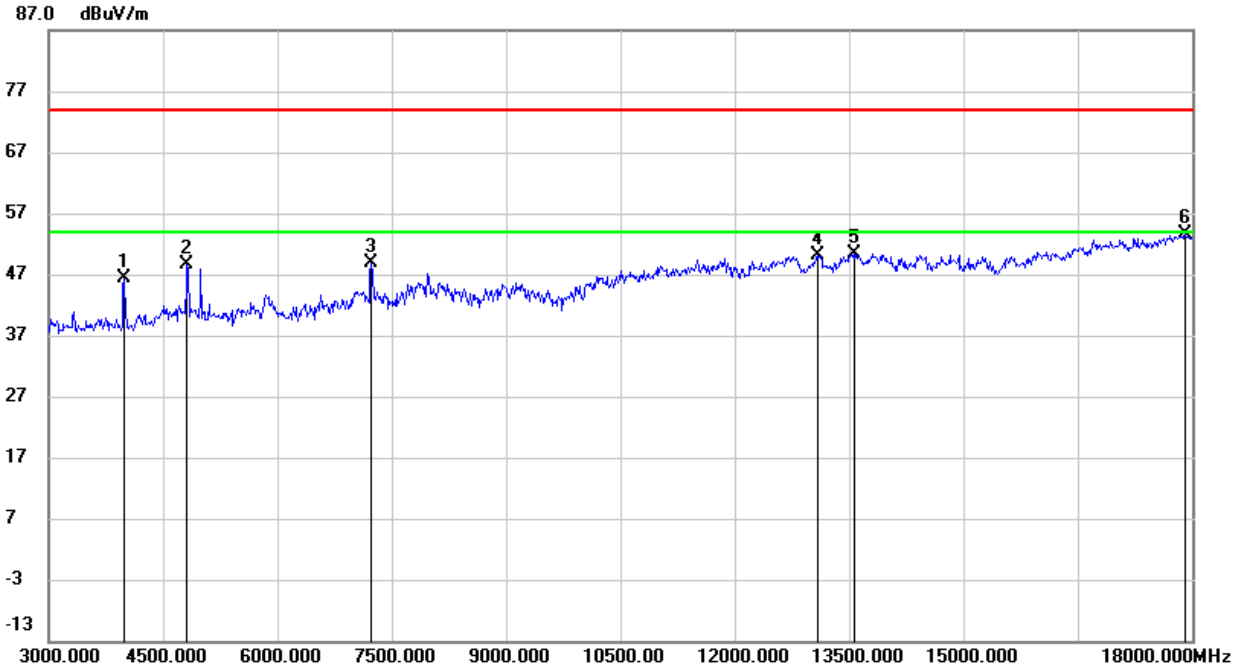

No.	Frequency (MHz)	Reading (dBuV)	Correct (dB/m)	Result (dBuV/m)	Limit (dBuV/m)	Margin (dB)	Remark
1	3990.000	49.31	-2.89	46.42	74.00	-27.58	peak
2	4815.000	48.08	0.51	48.59	74.00	-25.41	peak
3	7230.000	42.99	5.89	48.88	74.00	-25.12	peak
4	13080.000	34.94	15.16	50.10	74.00	-23.90	peak
5	13560.000	34.53	15.93	50.46	74.00	-23.54	peak
6	17910.000	30.22	23.35	53.57	74.00	-20.43	peak

- Note: 1. Measurement = Reading Level + Correct Factor.
 2. If Peak Result complies with AV limit, AV Result is deemed to comply with AV limit.
 3. Peak: Peak detector.
 4. Filter losses were only considered in the spurious frequency bands and the authorized band was not corrected for High Pass Filter losses.
 5. Proper operation of the transmitter prior to adding the filter to the measurement chain.



HARMONICS AND SPURIOUS EMISSIONS (CHANNEL 1, VERTICAL)

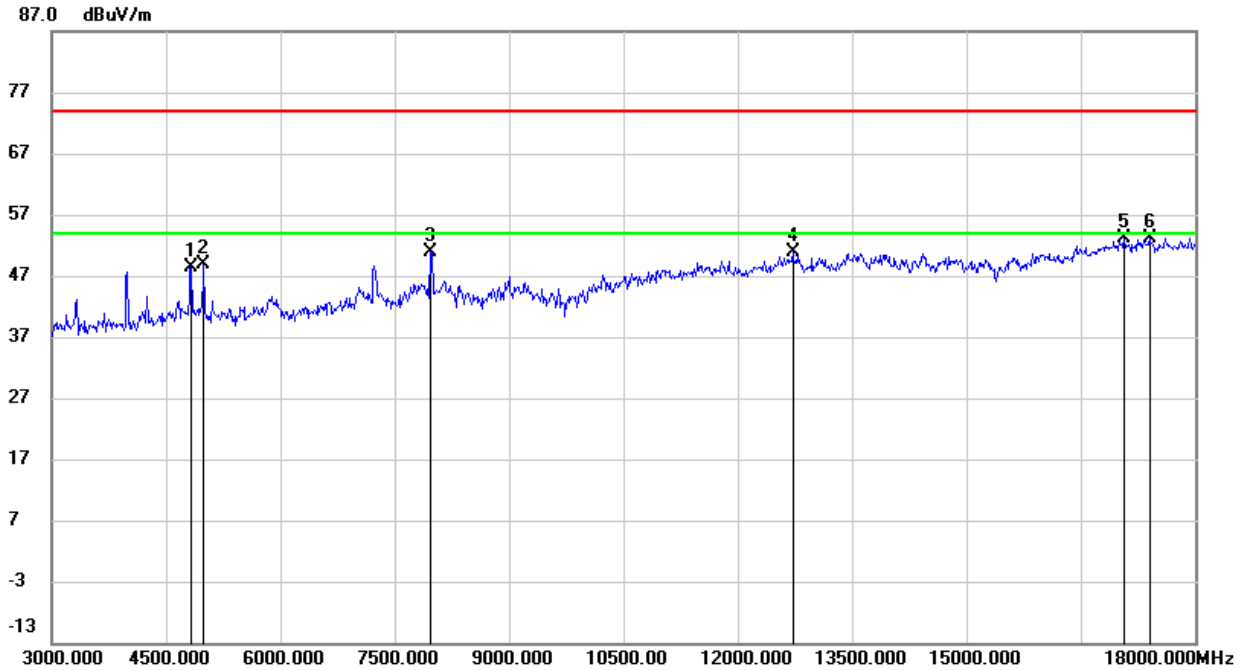

No.	Frequency (MHz)	Reading (dBuV)	Correct (dB/m)	Result (dBuV/m)	Limit (dBuV/m)	Margin (dB)	Remark
1	4830.000	47.78	0.59	48.37	74.00	-25.63	peak
2	4995.000	47.63	1.37	49.00	74.00	-25.00	peak
3	7965.000	43.92	7.00	50.92	74.00	-23.08	peak
4	12720.000	36.29	14.57	50.86	74.00	-23.14	peak
5	17070.000	32.54	20.57	53.11	74.00	-20.89	peak
6	17400.000	31.77	21.41	53.18	74.00	-20.82	peak

- Note: 1. Measurement = Reading Level + Correct Factor.
 2. If Peak Result complies with AV limit, AV Result is deemed to comply with AV limit.
 3. Peak: Peak detector.
 4. Filter losses were only considered in the spurious frequency bands and the authorized band was not corrected for High Pass Filter losses.
 5. Proper operation of the transmitter prior to adding the filter to the measurement chain.



HARMONICS AND SPURIOUS EMISSIONS (CHANNEL 2, HORIZONTAL)

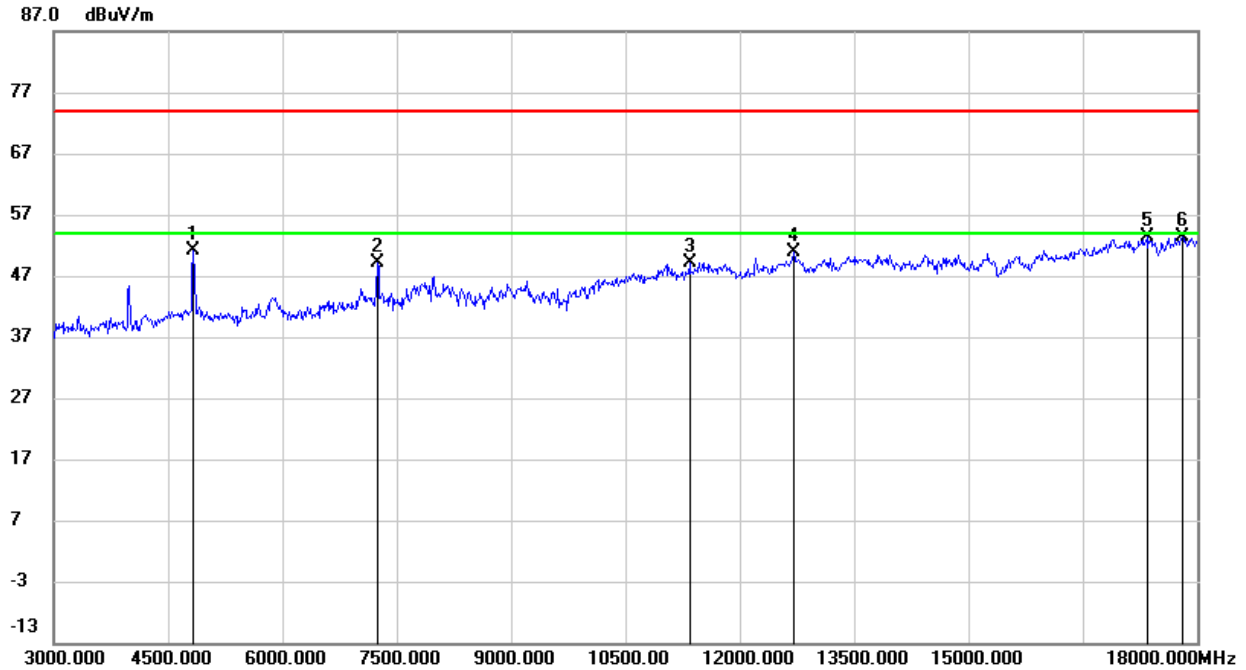

No.	Frequency (MHz)	Reading (dBuV)	Correct (dB/m)	Result (dBuV/m)	Limit (dBuV/m)	Margin (dB)	Remark
1	4830.000	50.65	0.59	51.24	74.00	-22.76	peak
2	7245.000	43.24	5.92	49.16	74.00	-24.84	peak
3	11340.000	36.79	12.45	49.24	74.00	-24.76	peak
4	12705.000	36.49	14.35	50.84	74.00	-23.16	peak
5	17340.000	31.65	21.61	53.26	74.00	-20.74	peak
6	17805.000	30.07	23.31	53.38	74.00	-20.62	peak

- Note: 1. Measurement = Reading Level + Correct Factor.
 2. If Peak Result complies with AV limit, AV Result is deemed to comply with AV limit.
 3. Peak: Peak detector.
 4. Filter losses were only considered in the spurious frequency bands and the authorized band was not corrected for High Pass Filter losses.
 5. Proper operation of the transmitter prior to adding the filter to the measurement chain.



HARMONICS AND SPURIOUS EMISSIONS (CHANNEL 2, VERTICAL)

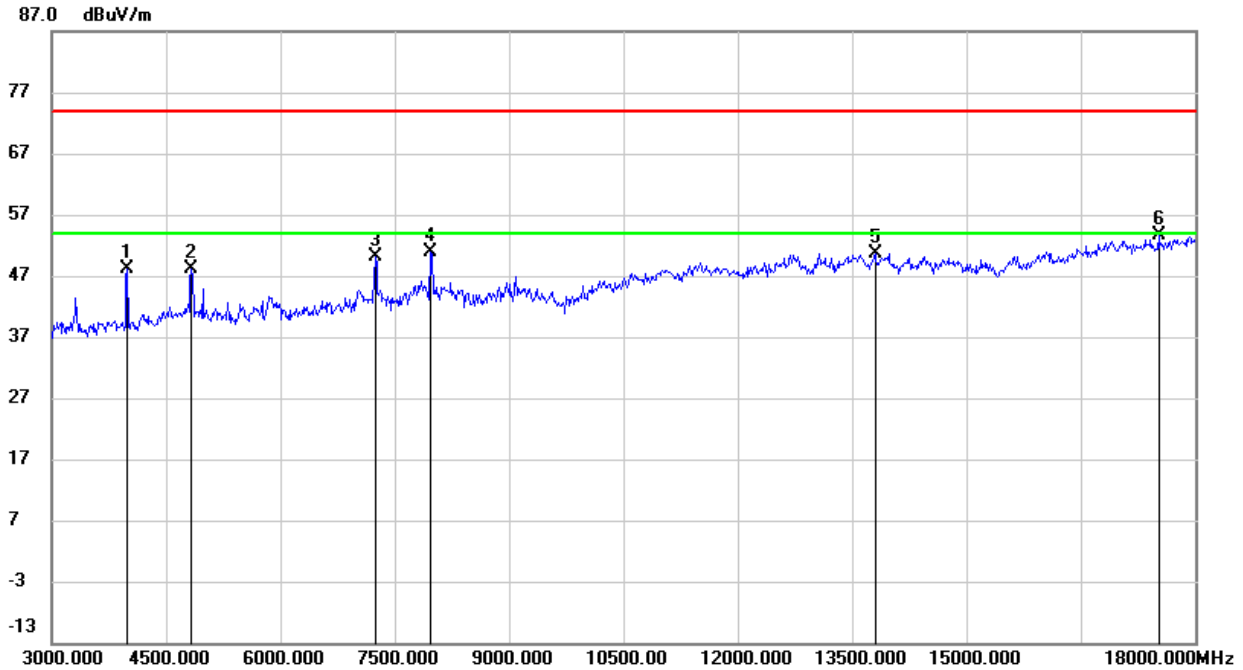

No.	Frequency (MHz)	Reading (dBuV)	Correct (dB/m)	Result (dBuV/m)	Limit (dBuV/m)	Margin (dB)	Remark
1	3990.000	51.12	-2.89	48.23	74.00	-25.77	peak
2	4830.000	47.50	0.59	48.09	74.00	-25.91	peak
3	7245.000	44.23	5.92	50.15	74.00	-23.85	peak
4	7965.000	43.87	7.00	50.87	74.00	-23.13	peak
5	13800.000	33.61	17.10	50.71	74.00	-23.29	peak
6	17520.000	32.19	21.44	53.63	74.00	-20.37	peak

- Note: 1. Measurement = Reading Level + Correct Factor.
 2. If Peak Result complies with AV limit, AV Result is deemed to comply with AV limit.
 3. Peak: Peak detector.
 4. Filter losses were only considered in the spurious frequency bands and the authorized band was not corrected for High Pass Filter losses.
 5. Proper operation of the transmitter prior to adding the filter to the measurement chain.



HARMONICS AND SPURIOUS EMISSIONS (CHANNEL 6, HORIZONTAL)

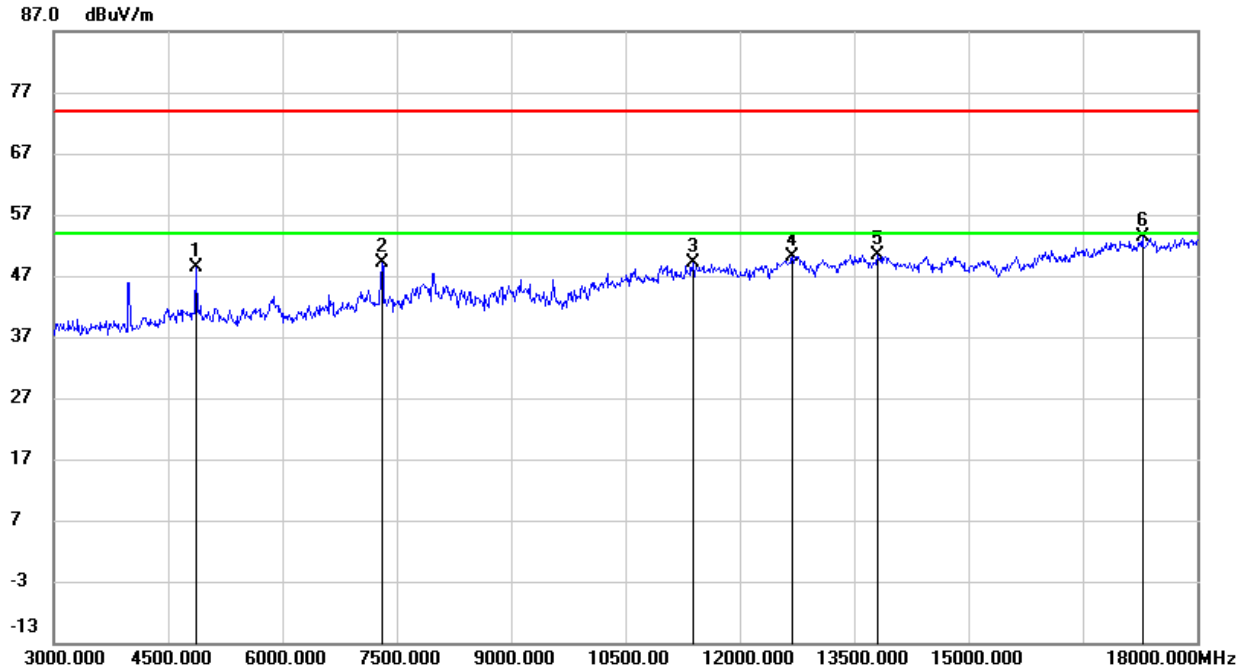

No.	Frequency (MHz)	Reading (dBuV)	Correct (dB/m)	Result (dBuV/m)	Limit (dBuV/m)	Margin (dB)	Remark
1	4860.000	47.56	0.70	48.26	74.00	-25.74	peak
2	7305.000	43.10	6.08	49.18	74.00	-24.82	peak
3	11385.000	36.61	12.58	49.19	74.00	-24.81	peak
4	12690.000	36.00	14.25	50.25	74.00	-23.75	peak
5	13800.000	33.37	17.10	50.47	74.00	-23.53	peak
6	17280.000	31.83	21.59	53.42	74.00	-20.58	peak

- Note: 1. Measurement = Reading Level + Correct Factor.
 2. If Peak Result complies with AV limit, AV Result is deemed to comply with AV limit.
 3. Peak: Peak detector.
 4. Filter losses were only considered in the spurious frequency bands and the authorized band was not corrected for High Pass Filter losses.
 5. Proper operation of the transmitter prior to adding the filter to the measurement chain.



HARMONICS AND SPURIOUS EMISSIONS (CHANNEL 6, VERTICAL)

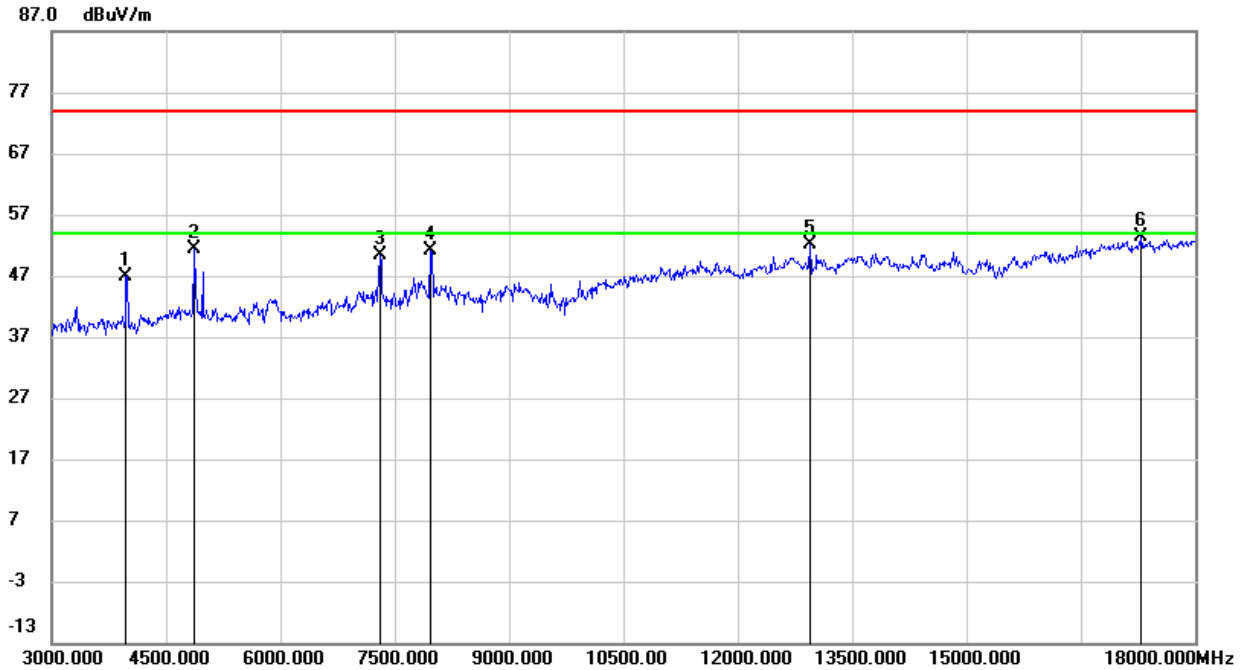

No.	Frequency (MHz)	Reading (dBuV)	Correct (dB/m)	Result (dBuV/m)	Limit (dBuV/m)	Margin (dB)	Remark
1	3975.000	49.78	-2.90	46.88	74.00	-27.12	peak
2	4875.000	50.57	0.76	51.33	74.00	-22.67	peak
3	7305.000	44.41	6.08	50.49	74.00	-23.51	peak
4	7965.000	44.24	7.00	51.24	74.00	-22.76	peak
5	12945.000	37.12	14.92	52.04	74.00	-21.96	QP
6	17295.000	31.61	21.71	53.32	74.00	-20.68	peak

- Note: 1. Measurement = Reading Level + Correct Factor.
 2. If Peak Result complies with AV limit, AV Result is deemed to comply with AV limit.
 3. Peak: Peak detector.
 4. Filter losses were only considered in the spurious frequency bands and the authorized band was not corrected for High Pass Filter losses.
 5. Proper operation of the transmitter prior to adding the filter to the measurement chain.



HARMONICS AND SPURIOUS EMISSIONS (CHANNEL 10, HORIZONTAL)

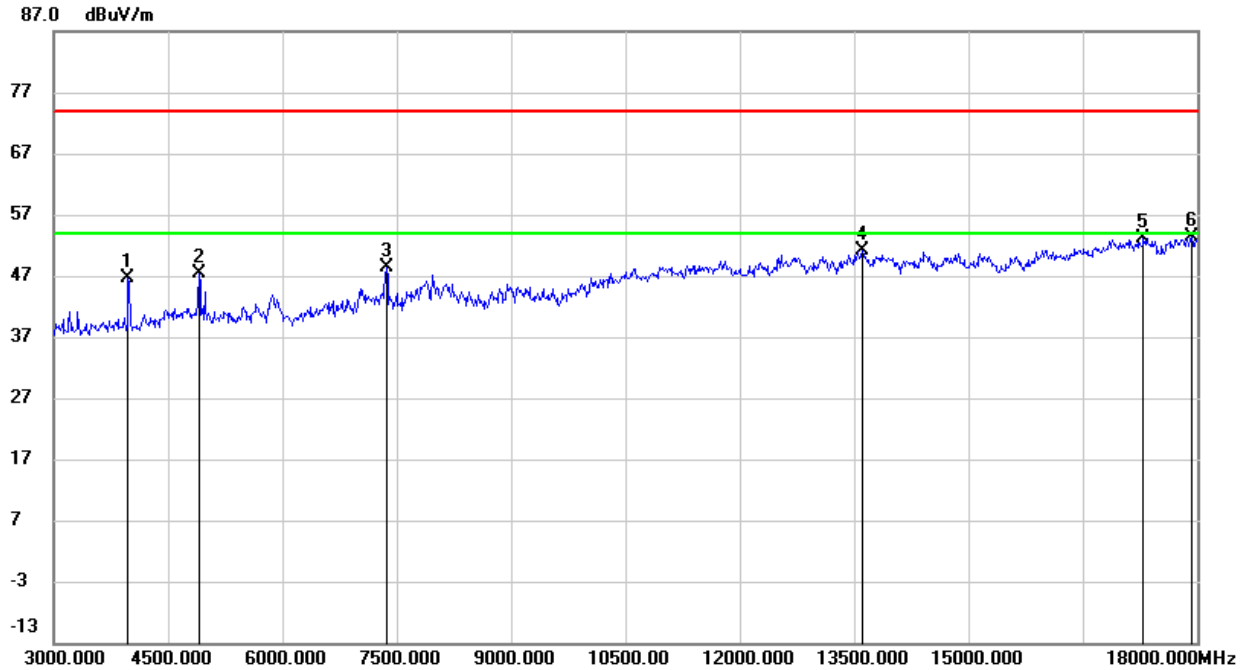

No.	Frequency (MHz)	Reading (dBuV)	Correct (dB/m)	Result (dBuV/m)	Limit (dBuV/m)	Margin (dB)	Remark
1	3975.000	49.65	-2.90	46.75	74.00	-27.25	peak
2	4905.000	46.48	0.88	47.36	74.00	-26.64	peak
3	7365.000	41.93	6.34	48.27	74.00	-25.73	peak
4	13605.000	35.17	16.02	51.19	74.00	-22.81	peak
5	17295.000	31.51	21.71	53.22	74.00	-20.78	peak
6	17925.000	30.06	23.37	53.43	74.00	-20.57	peak

- Note: 1. Measurement = Reading Level + Correct Factor.
 2. If Peak Result complies with AV limit, AV Result is deemed to comply with AV limit.
 3. Peak: Peak detector.
 4. Filter losses were only considered in the spurious frequency bands and the authorized band was not corrected for High Pass Filter losses.
 5. Proper operation of the transmitter prior to adding the filter to the measurement chain.



HARMONICS AND SPURIOUS EMISSIONS (CHANNEL 10, VERTICAL)

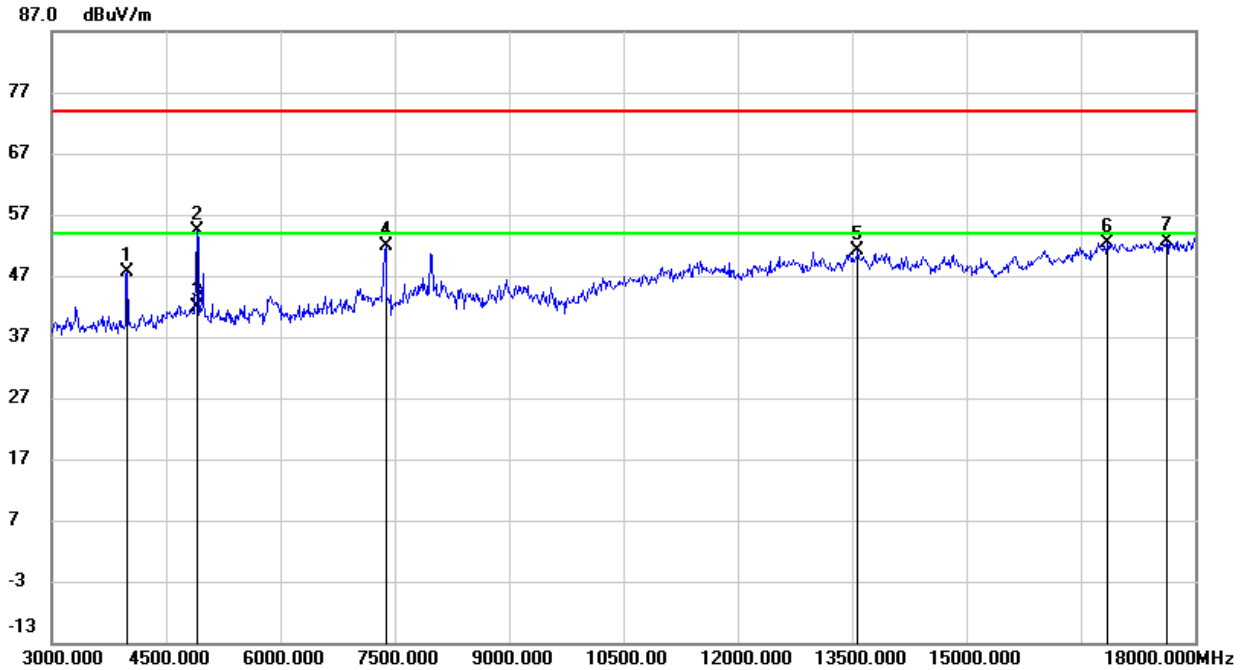

No.	Frequency (MHz)	Reading (dBuV)	Correct (dB/m)	Result (dBuV/m)	Limit (dBuV/m)	Margin (dB)	Remark
1	3990.000	50.45	-2.89	47.56	74.00	-26.44	peak
2	4905.000	53.51	0.88	54.39	74.00	-19.61	peak
3	4905.000	41.00	0.88	41.88	54.00	-12.12	AVG
4	7380.000	45.53	6.41	51.94	74.00	-22.06	peak
5	13575.000	35.13	15.97	51.10	74.00	-22.90	peak
6	16845.000	32.44	19.96	52.40	74.00	-21.60	peak
7	17625.000	30.74	21.95	52.69	74.00	-21.31	peak

- Note: 1. Measurement = Reading Level + Correct Factor.
 2. If Peak Result complies with AV limit, AV Result is deemed to comply with AV limit.
 3. Peak: Peak detector.
 4. Filter losses were only considered in the spurious frequency bands and the authorized band was not corrected for High Pass Filter losses.
 5. Proper operation of the transmitter prior to adding the filter to the measurement chain.



HARMONICS AND SPURIOUS EMISSIONS (CHANNEL 11, HORIZONTAL)

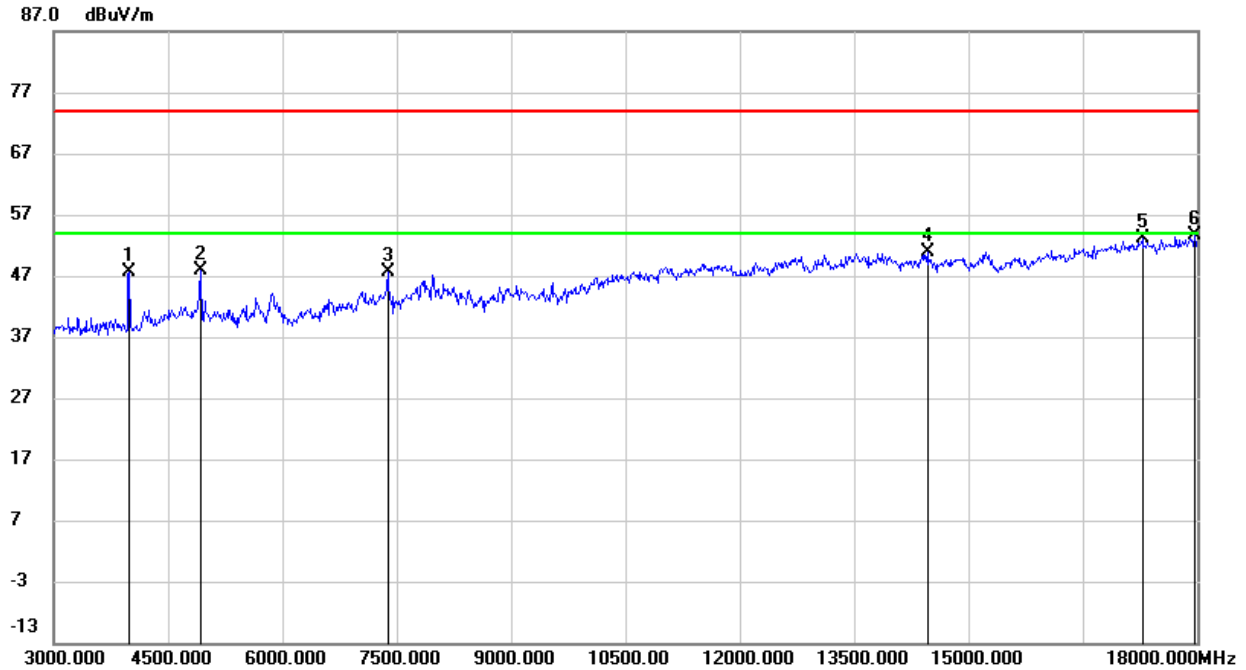

No.	Frequency (MHz)	Reading (dBuV)	Correct (dB/m)	Result (dBuV/m)	Limit (dBuV/m)	Margin (dB)	Remark
1	3990.000	50.48	-2.89	47.59	74.00	-26.41	peak
2	4920.000	46.93	0.96	47.89	74.00	-26.11	peak
3	7380.000	41.22	6.41	47.63	74.00	-26.37	peak
4	14460.000	34.45	16.36	50.81	74.00	-23.19	peak
5	17280.000	31.58	21.59	53.17	74.00	-20.83	peak
6	17970.000	30.24	23.42	53.66	74.00	-20.34	peak

- Note: 1. Measurement = Reading Level + Correct Factor.
 2. If Peak Result complies with AV limit, AV Result is deemed to comply with AV limit.
 3. Peak: Peak detector.
 4. Filter losses were only considered in the spurious frequency bands and the authorized band was not corrected for High Pass Filter losses.
 5. Proper operation of the transmitter prior to adding the filter to the measurement chain.



HARMONICS AND SPURIOUS EMISSIONS (CHANNEL 11, VERTICAL)

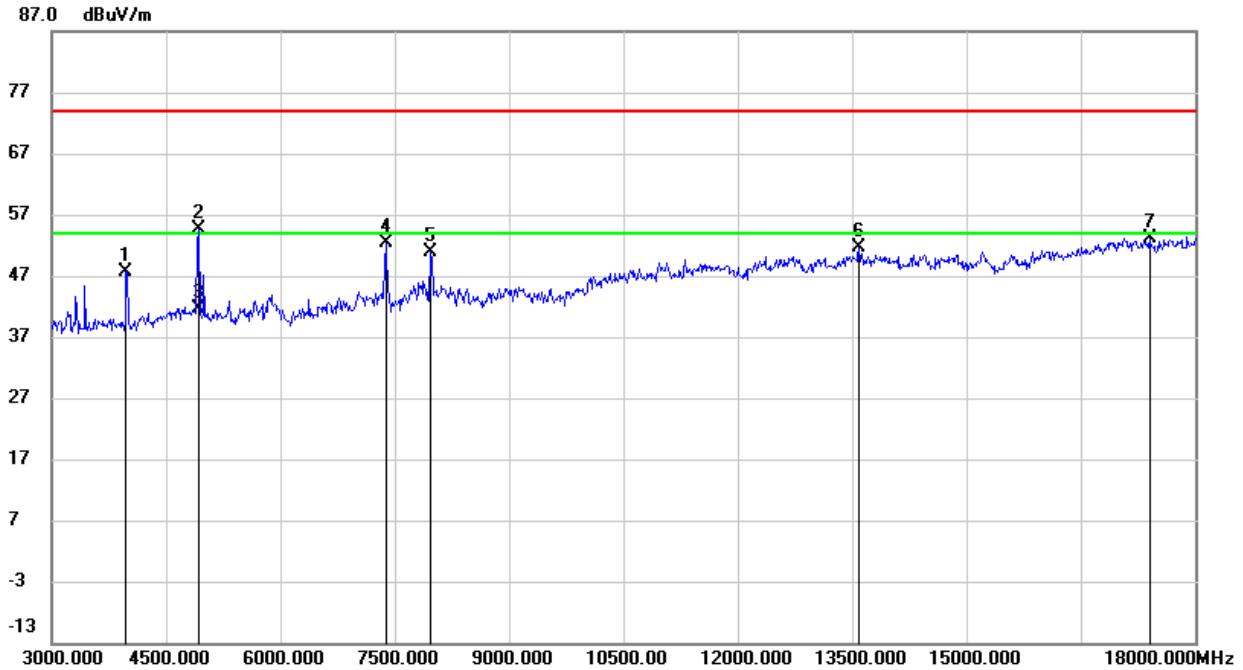

No.	Frequency (MHz)	Reading (dBuV)	Correct (dB/m)	Result (dBuV/m)	Limit (dBuV/m)	Margin (dB)	Remark
1	3975.000	50.57	-2.90	47.67	74.00	-26.33	peak
2	4920.000	53.64	0.96	54.60	74.00	-19.40	peak
3	4920.000	40.68	0.96	41.64	54.00	-12.36	AVG
4	7380.000	46.01	6.41	52.42	74.00	-21.58	peak
5	7965.000	43.78	7.00	50.78	74.00	-23.22	peak
6	13590.000	35.52	16.00	51.52	74.00	-22.48	peak
7	17400.000	31.82	21.41	53.23	74.00	-20.77	peak

- Note: 1. Measurement = Reading Level + Correct Factor.
 2. If Peak Result complies with AV limit, AV Result is deemed to comply with AV limit.
 3. Peak: Peak detector.
 4. Filter losses were only considered in the spurious frequency bands and the authorized band was not corrected for High Pass Filter losses.
 5. Proper operation of the transmitter prior to adding the filter to the measurement chain.



8.2.3. 802.11n HT20 MODE

HARMONICS AND SPURIOUS EMISSIONS (CHANNEL 1, HORIZONTAL)

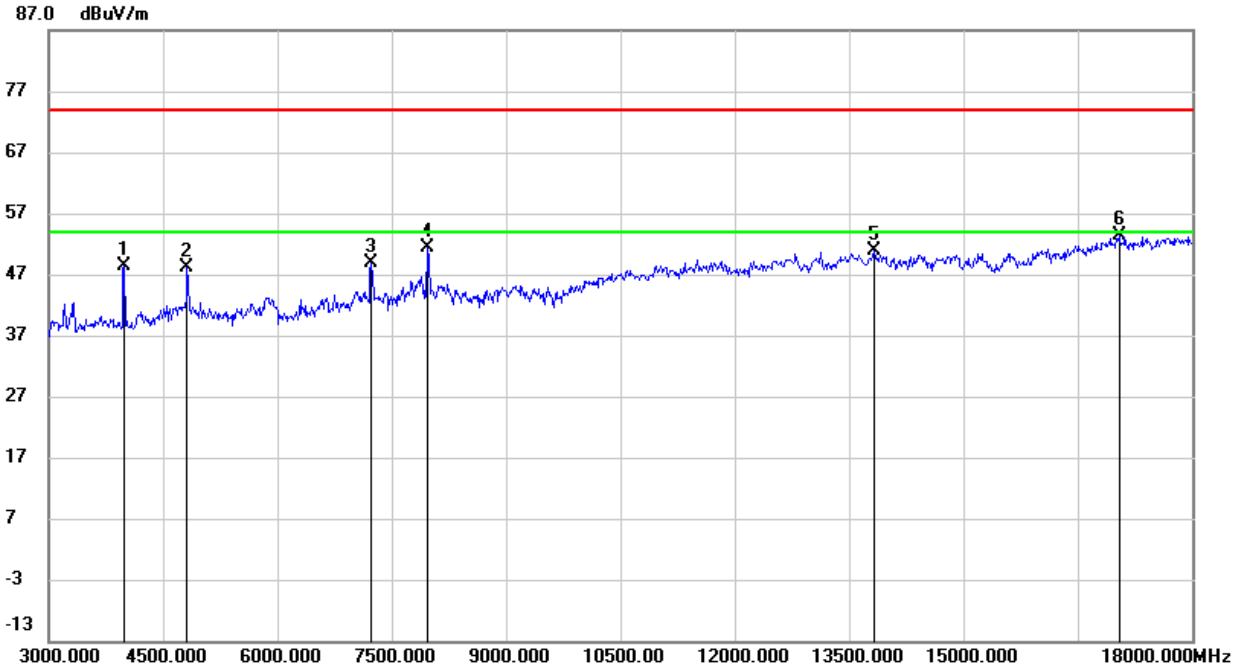

No.	Frequency (MHz)	Reading (dBuV)	Correct (dB/m)	Result (dBuV/m)	Limit (dBuV/m)	Margin (dB)	Remark
1	3990.000	51.35	-2.89	48.46	74.00	-25.54	peak
2	4815.000	47.58	0.51	48.09	74.00	-25.91	peak
3	7230.000	43.00	5.89	48.89	74.00	-25.11	peak
4	7965.000	44.30	7.00	51.30	74.00	-22.70	peak
5	13830.000	33.97	16.84	50.81	74.00	-23.19	peak
6	17040.000	32.96	20.49	53.45	74.00	-20.55	peak

- Note: 1. Measurement = Reading Level + Correct Factor.
 2. If Peak Result complies with AV limit, AV Result is deemed to comply with AV limit.
 3. Peak: Peak detector.
 4. Filter losses were only considered in the spurious frequency bands and the authorized band was not corrected for High Pass Filter losses.
 5. Proper operation of the transmitter prior to adding the filter to the measurement chain.



HARMONICS AND SPURIOUS EMISSIONS (CHANNEL 1, VERTICAL)

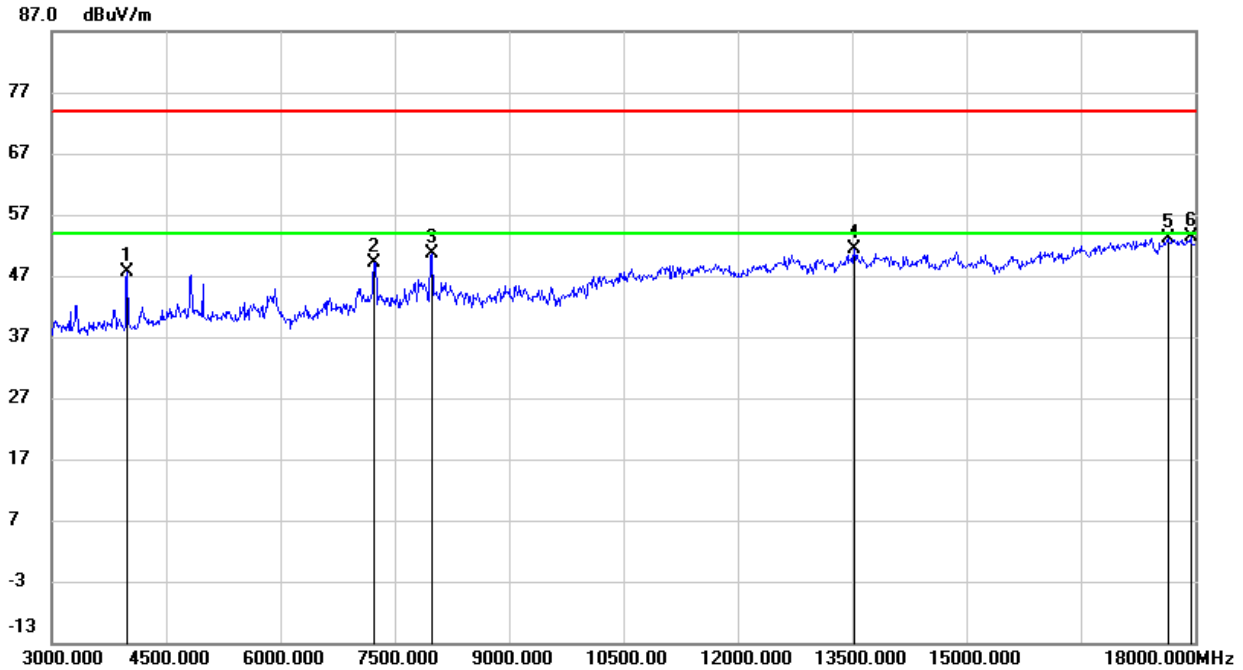

No.	Frequency (MHz)	Reading (dBuV)	Correct (dB/m)	Result (dBuV/m)	Limit (dBuV/m)	Margin (dB)	Remark
1	3990.000	50.41	-2.89	47.52	74.00	-26.48	peak
2	7230.000	43.25	5.89	49.14	74.00	-24.86	peak
3	7995.000	43.81	6.89	50.70	74.00	-23.30	peak
4	13530.000	35.44	15.86	51.30	74.00	-22.70	peak
5	17640.000	31.15	22.05	53.20	74.00	-20.80	peak
6	17940.000	29.90	23.39	53.29	74.00	-20.71	peak

- Note: 1. Measurement = Reading Level + Correct Factor.
 2. If Peak Result complies with AV limit, AV Result is deemed to comply with AV limit.
 3. Peak: Peak detector.
 4. Filter losses were only considered in the spurious frequency bands and the authorized band was not corrected for High Pass Filter losses.
 5. Proper operation of the transmitter prior to adding the filter to the measurement chain.



HARMONICS AND SPURIOUS EMISSIONS (CHANNEL 2, HORIZONTAL)

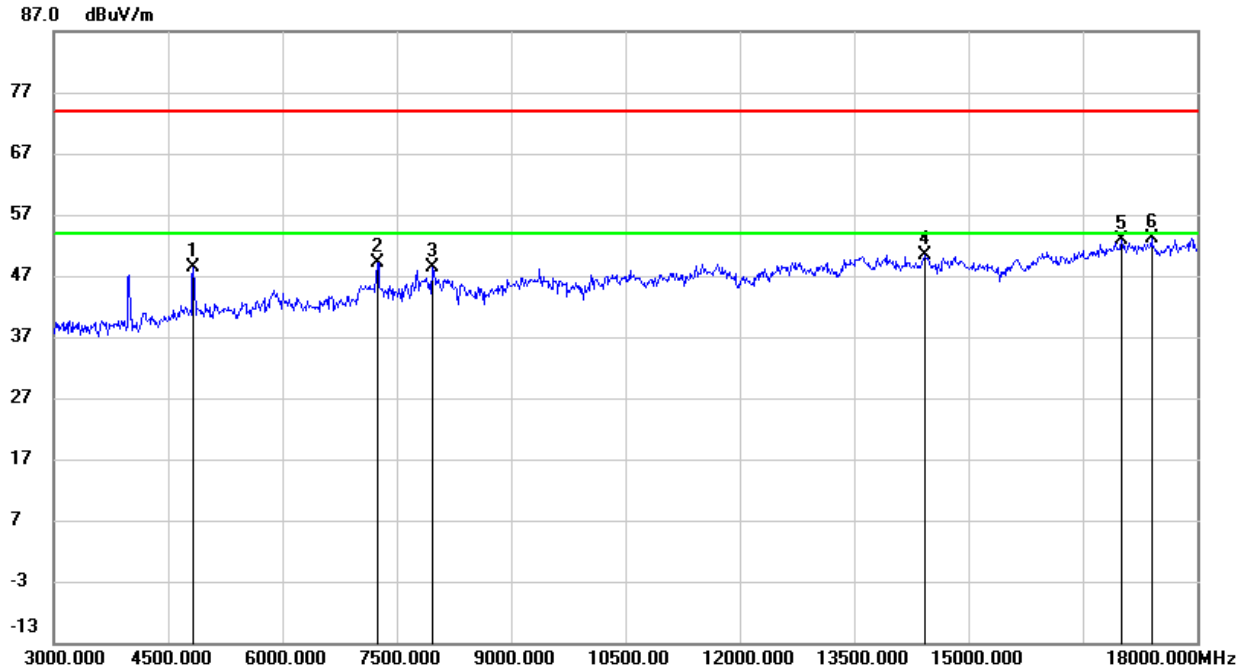

No.	Frequency (MHz)	Reading (dBuV)	Correct (dB/m)	Result (dBuV/m)	Limit (dBuV/m)	Margin (dB)	Remark
1	4830.000	47.72	0.59	48.31	74.00	-25.69	peak
2	7245.000	43.31	5.92	49.23	74.00	-24.77	peak
3	7965.000	41.27	7.00	48.27	74.00	-25.73	peak
4	14430.000	34.06	16.35	50.41	74.00	-23.59	peak
5	17010.000	32.56	20.43	52.99	74.00	-21.01	peak
6	17400.000	31.77	21.41	53.18	74.00	-20.82	peak

- Note: 1. Measurement = Reading Level + Correct Factor.
 2. If Peak Result complies with AV limit, AV Result is deemed to comply with AV limit.
 3. Peak: Peak detector.
 4. Filter losses were only considered in the spurious frequency bands and the authorized band was not corrected for High Pass Filter losses.
 5. Proper operation of the transmitter prior to adding the filter to the measurement chain.



HARMONICS AND SPURIOUS EMISSIONS (CHANNEL 2, VERTICAL)

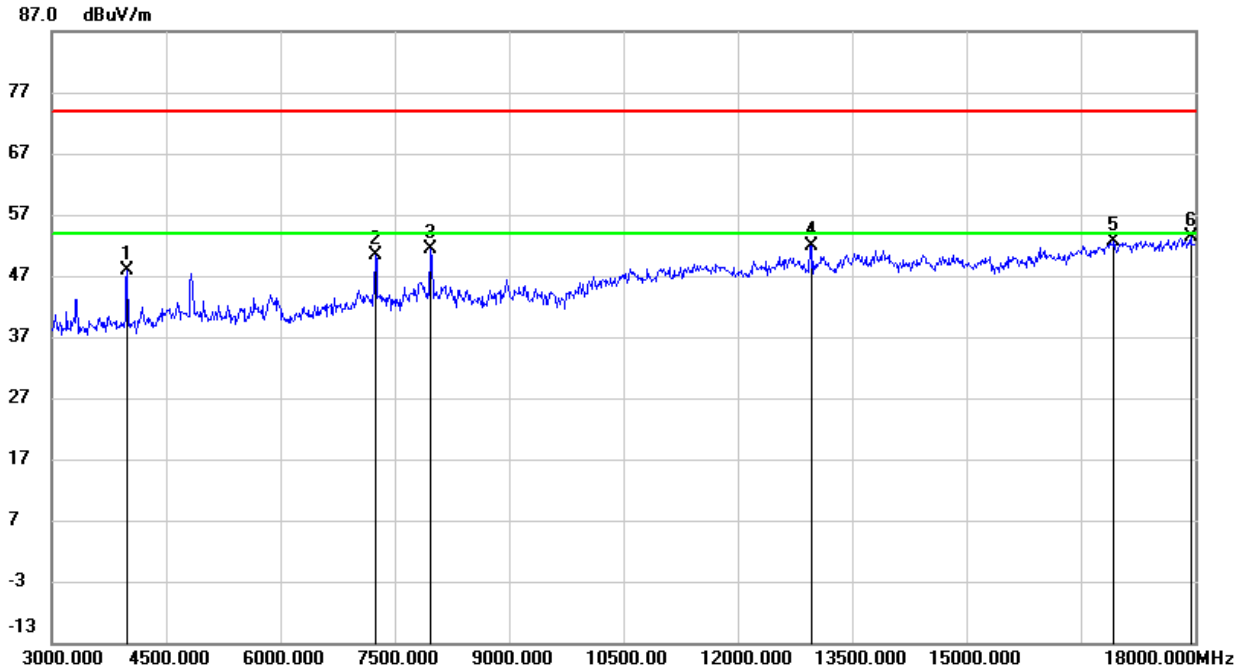

No.	Frequency (MHz)	Reading (dBuV)	Correct (dB/m)	Result (dBuV/m)	Limit (dBuV/m)	Margin (dB)	Remark
1	3990.000	50.82	-2.89	47.93	74.00	-26.07	peak
2	7245.000	44.43	5.92	50.35	74.00	-23.65	peak
3	7965.000	44.41	7.00	51.41	74.00	-22.59	peak
4	12975.000	37.01	14.93	51.94	74.00	-22.06	peak
5	16935.000	32.62	20.12	52.74	74.00	-21.26	peak
6	17940.000	30.08	23.39	53.47	74.00	-20.53	peak

- Note: 1. Measurement = Reading Level + Correct Factor.
 2. If Peak Result complies with AV limit, AV Result is deemed to comply with AV limit.
 3. Peak: Peak detector.
 4. Filter losses were only considered in the spurious frequency bands and the authorized band was not corrected for High Pass Filter losses.
 5. Proper operation of the transmitter prior to adding the filter to the measurement chain.



HARMONICS AND SPURIOUS EMISSIONS (CHANNEL 6, HORIZONTAL)

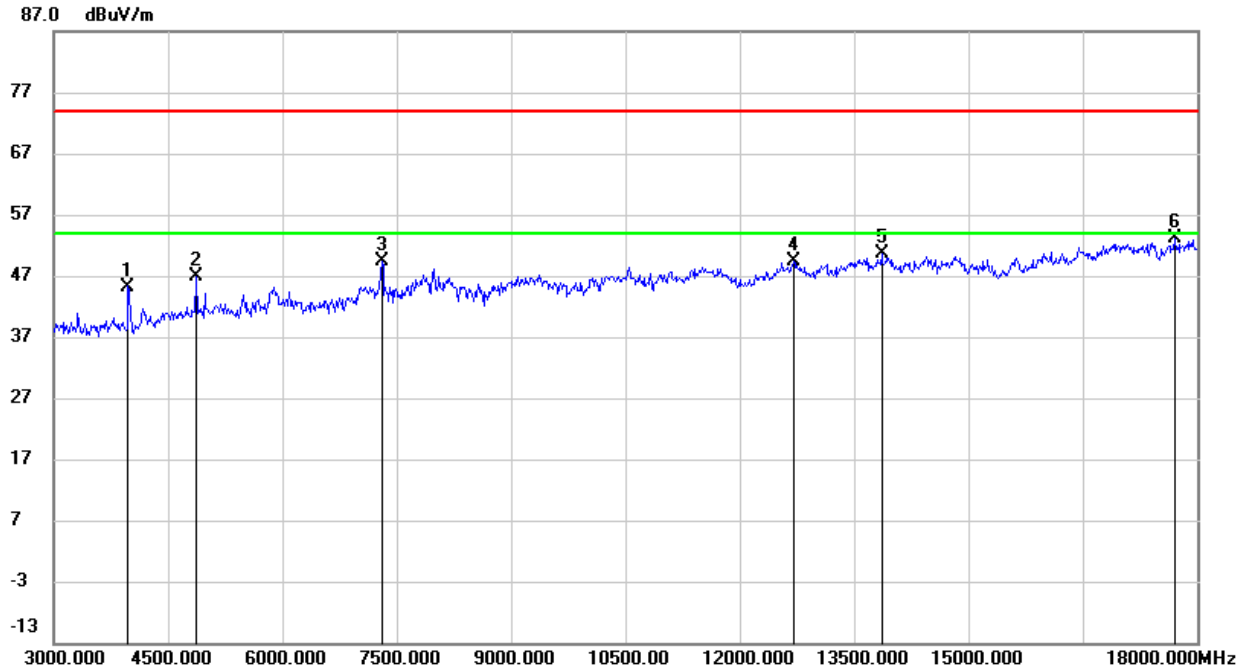

No.	Frequency (MHz)	Reading (dBuV)	Correct (dB/m)	Result (dBuV/m)	Limit (dBuV/m)	Margin (dB)	Remark
1	3975.000	48.15	-2.90	45.25	74.00	-28.75	peak
2	4875.000	46.17	0.76	46.93	74.00	-27.07	peak
3	7305.000	43.29	6.08	49.37	74.00	-24.63	peak
4	12705.000	35.14	14.35	49.49	74.00	-24.51	peak
5	13860.000	34.17	16.56	50.73	74.00	-23.27	peak
6	17700.000	30.63	22.43	53.06	74.00	-20.94	peak

- Note: 1. Measurement = Reading Level + Correct Factor.
 2. If Peak Result complies with AV limit, AV Result is deemed to comply with AV limit.
 3. Peak: Peak detector.
 4. Filter losses were only considered in the spurious frequency bands and the authorized band was not corrected for High Pass Filter losses.
 5. Proper operation of the transmitter prior to adding the filter to the measurement chain.



HARMONICS AND SPURIOUS EMISSIONS (CHANNEL 6, VERTICAL)

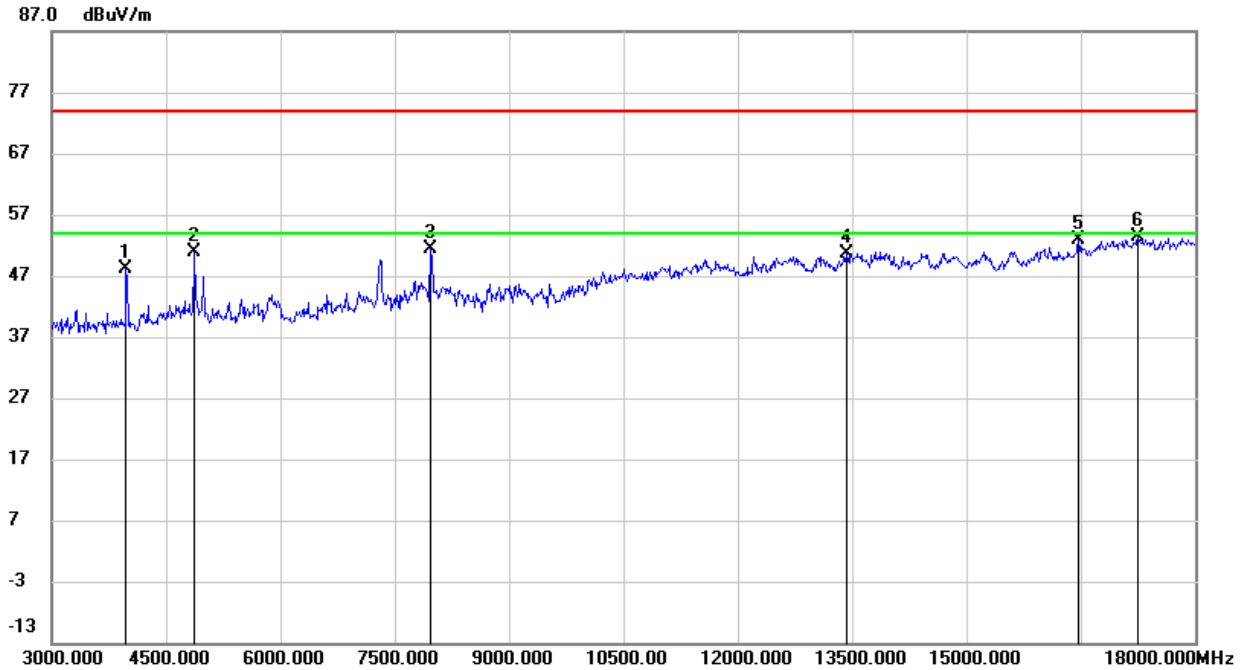

No.	Frequency (MHz)	Reading (dBuV)	Correct (dB/m)	Result (dBuV/m)	Limit (dBuV/m)	Margin (dB)	Remark
1	3975.000	51.11	-2.90	48.21	74.00	-25.79	peak
2	4875.000	50.15	0.76	50.91	74.00	-23.09	peak
3	7965.000	44.26	7.00	51.26	74.00	-22.74	peak
4	13425.000	34.69	16.02	50.71	74.00	-23.29	peak
5	16470.000	33.87	19.06	52.93	74.00	-21.07	peak
6	17250.000	32.07	21.33	53.40	74.00	-20.60	peak

- Note: 1. Measurement = Reading Level + Correct Factor.
 2. If Peak Result complies with AV limit, AV Result is deemed to comply with AV limit.
 3. Peak: Peak detector.
 4. Filter losses were only considered in the spurious frequency bands and the authorized band was not corrected for High Pass Filter losses.
 5. Proper operation of the transmitter prior to adding the filter to the measurement chain.



HARMONICS AND SPURIOUS EMISSIONS (CHANNEL 10, HORIZONTAL)

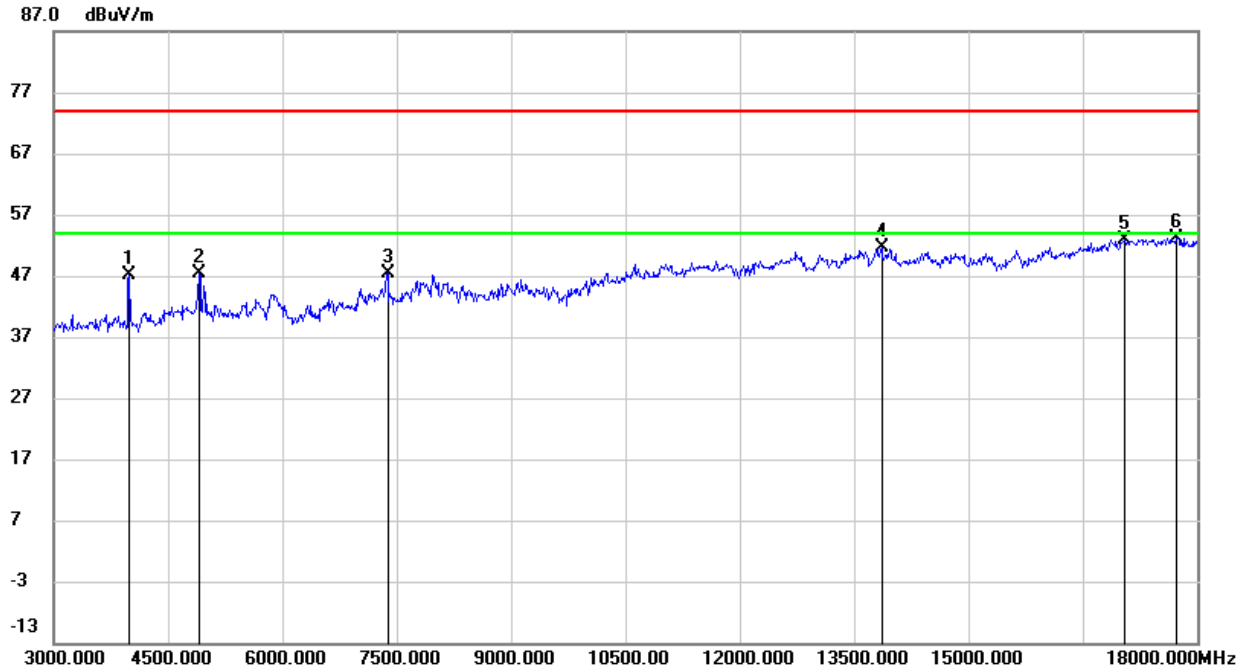

No.	Frequency (MHz)	Reading (dBuV)	Correct (dB/m)	Result (dBuV/m)	Limit (dBuV/m)	Margin (dB)	Remark
1	3990.000	50.08	-2.89	47.19	74.00	-26.81	peak
2	4905.000	46.59	0.88	47.47	74.00	-26.53	peak
3	7380.000	40.99	6.41	47.40	74.00	-26.60	peak
4	13860.000	34.96	16.56	51.52	74.00	-22.48	peak
5	17055.000	32.29	20.53	52.82	74.00	-21.18	peak
6	17730.000	30.49	22.70	53.19	74.00	-20.81	peak

- Note: 1. Measurement = Reading Level + Correct Factor.
 2. If Peak Result complies with AV limit, AV Result is deemed to comply with AV limit.
 3. Peak: Peak detector.
 4. Filter losses were only considered in the spurious frequency bands and the authorized band was not corrected for High Pass Filter losses.
 5. Proper operation of the transmitter prior to adding the filter to the measurement chain.



HARMONICS AND SPURIOUS EMISSIONS (CHANNEL 10, VERTICAL)

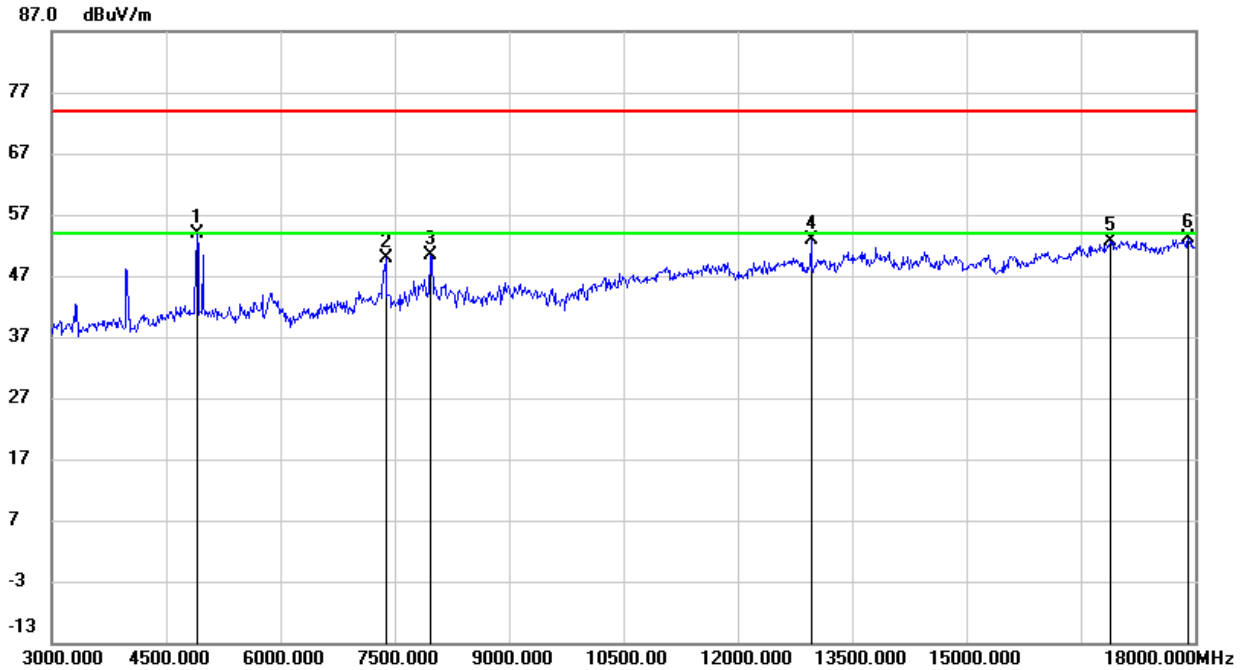

No.	Frequency (MHz)	Reading (dBuV)	Correct (dB/m)	Result (dBuV/m)	Limit (dBuV/m)	Margin (dB)	Remark
1	4905.000	52.94	0.88	53.82	74.00	-20.18	peak
2	7380.000	43.40	6.41	49.81	74.00	-24.19	peak
3	7965.000	43.29	7.00	50.29	74.00	-23.71	peak
4	12960.000	37.95	14.92	52.87	74.00	-21.13	peak
5	16890.000	32.72	19.97	52.69	74.00	-21.31	peak
6	17910.000	29.88	23.35	53.23	74.00	-20.77	peak

- Note: 1. Measurement = Reading Level + Correct Factor.
 2. If Peak Result complies with AV limit, AV Result is deemed to comply with AV limit.
 3. Peak: Peak detector.
 4. Filter losses were only considered in the spurious frequency bands and the authorized band was not corrected for High Pass Filter losses.
 5. Proper operation of the transmitter prior to adding the filter to the measurement chain.



HARMONICS AND SPURIOUS EMISSIONS (CHANNEL 11, HORIZONTAL)

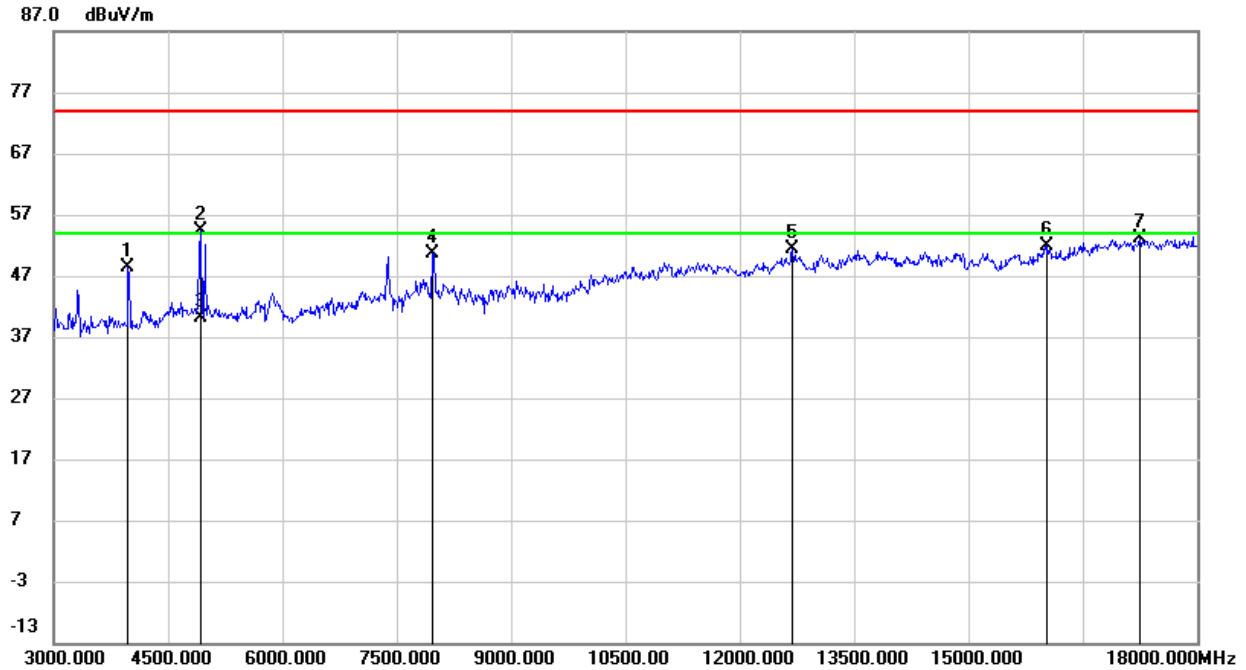

No.	Frequency (MHz)	Reading (dBuV)	Correct (dB/m)	Result (dBuV/m)	Limit (dBuV/m)	Margin (dB)	Remark
1	3975.000	51.17	-2.90	48.27	74.00	-25.73	peak
2	4920.000	53.44	0.96	54.40	74.00	-19.60	peak
3	4920.000	39.15	0.96	40.11	54.00	-13.89	AVG
4	7965.000	43.56	7.00	50.56	74.00	-23.44	peak
5	12690.000	37.09	14.25	51.34	74.00	-22.66	peak
6	16035.000	34.08	17.85	51.93	74.00	-22.07	peak
7	17250.000	31.69	21.33	53.02	74.00	-20.98	peak

- Note: 1. Measurement = Reading Level + Correct Factor.
 2. If Peak Result complies with AV limit, AV Result is deemed to comply with AV limit.
 3. Peak: Peak detector.
 4. Filter losses were only considered in the spurious frequency bands and the authorized band was not corrected for High Pass Filter losses.
 5. Proper operation of the transmitter prior to adding the filter to the measurement chain.



HARMONICS AND SPURIOUS EMISSIONS (CHANNEL 11, VERTICAL)

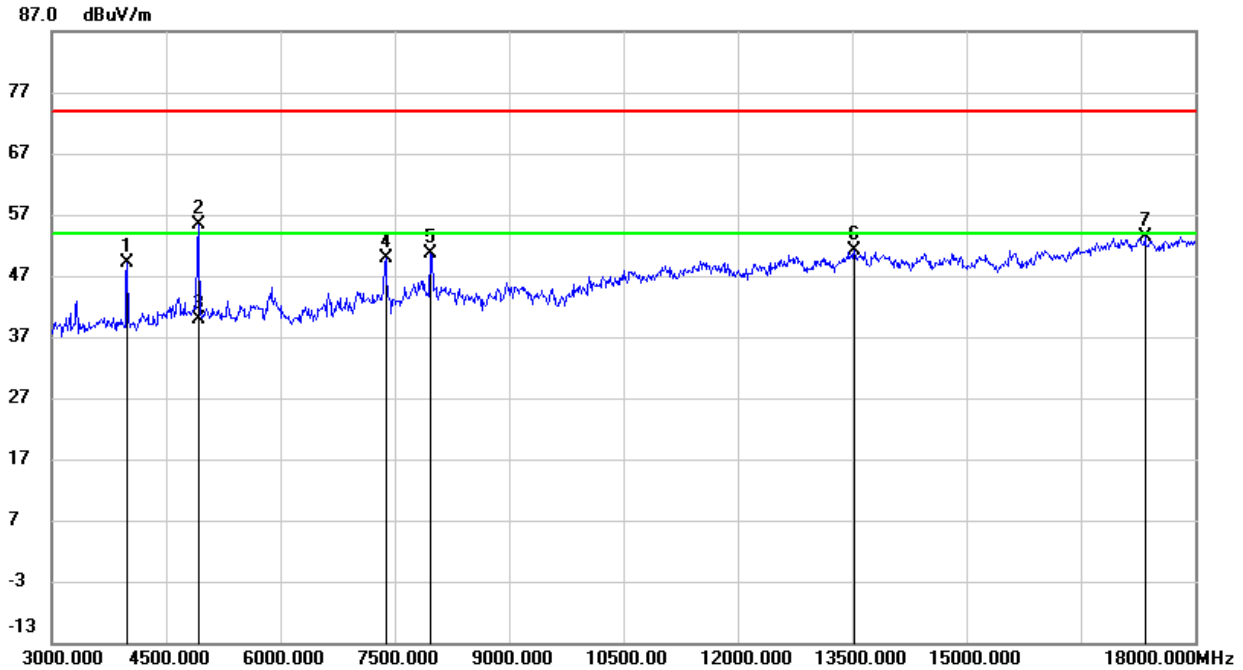

No.	Frequency (MHz)	Reading (dBuV)	Correct (dB/m)	Result (dBuV/m)	Limit (dBuV/m)	Margin (dB)	Remark
1	3990.000	52.12	-2.89	49.23	74.00	-24.77	peak
2	4920.000	54.30	0.96	55.26	74.00	-18.74	peak
3	4920.000	38.86	0.96	39.82	54.00	-14.18	AVG
4	7380.000	43.39	6.41	49.80	74.00	-24.20	peak
5	7965.000	43.70	7.00	50.70	74.00	-23.30	peak
6	13530.000	35.27	15.86	51.13	74.00	-22.87	peak
7	17340.000	31.72	21.61	53.33	74.00	-20.67	peak

- Note: 1. Measurement = Reading Level + Correct Factor.
 2. If Peak Result complies with AV limit, AV Result is deemed to comply with AV limit.
 3. Peak: Peak detector.
 4. Filter losses were only considered in the spurious frequency bands and the authorized band was not corrected for High Pass Filter losses.
 5. Proper operation of the transmitter prior to adding the filter to the measurement chain.



8.3. SPURIOUS EMISSIONS (1~3GHz)

8.3.1. 802.11b MODE

HARMONICS AND SPURIOUS EMISSIONS (CHANNEL 1, HORIZONTAL)

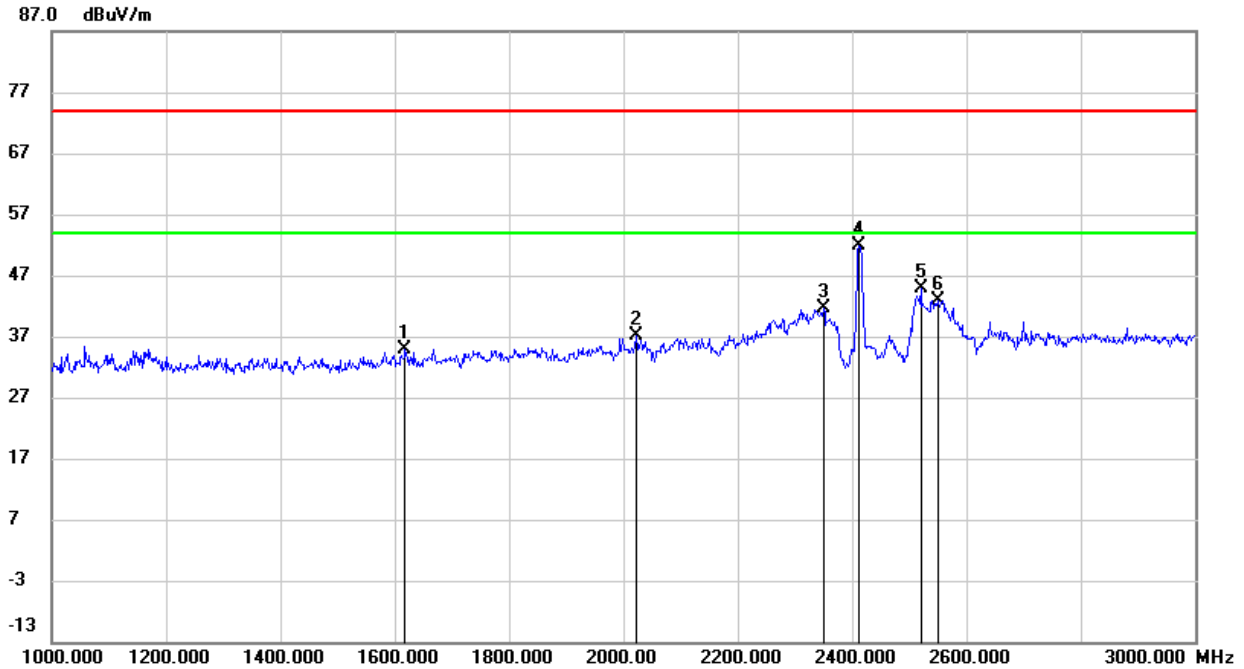

No.	Frequency (MHz)	Reading (dBuV)	Correct (dB/m)	Result (dBuV/m)	Limit (dBuV/m)	Margin (dB)	Remark
1	1618.000	46.20	-11.31	34.89	74.00	-39.11	peak
2	2022.000	46.70	-9.68	37.02	74.00	-36.98	peak
3	2350.000	49.65	-8.02	41.63	74.00	-32.37	peak
4	2412.000	59.68	-7.77	51.91	/	/	fundamental
5	2520.000	52.09	-7.27	44.82	74.00	-29.18	peak
6	2550.000	50.32	-7.44	42.88	74.00	-31.12	peak

- Note: 1. Measurement = Reading Level + Correct Factor.
 2. If Peak Result complies with AV limit, AV Result is deemed to comply with AV limit.
 3. Peak: Peak detector.
 4. Filter losses were only considered in the spurious frequency bands and the authorized band was not corrected for Band Reject Filter losses.
 5. Proper operation of the transmitter prior to adding the filter to the measurement chain.



HARMONICS AND SPURIOUS EMISSIONS (CHANNEL 1, VERTICAL)

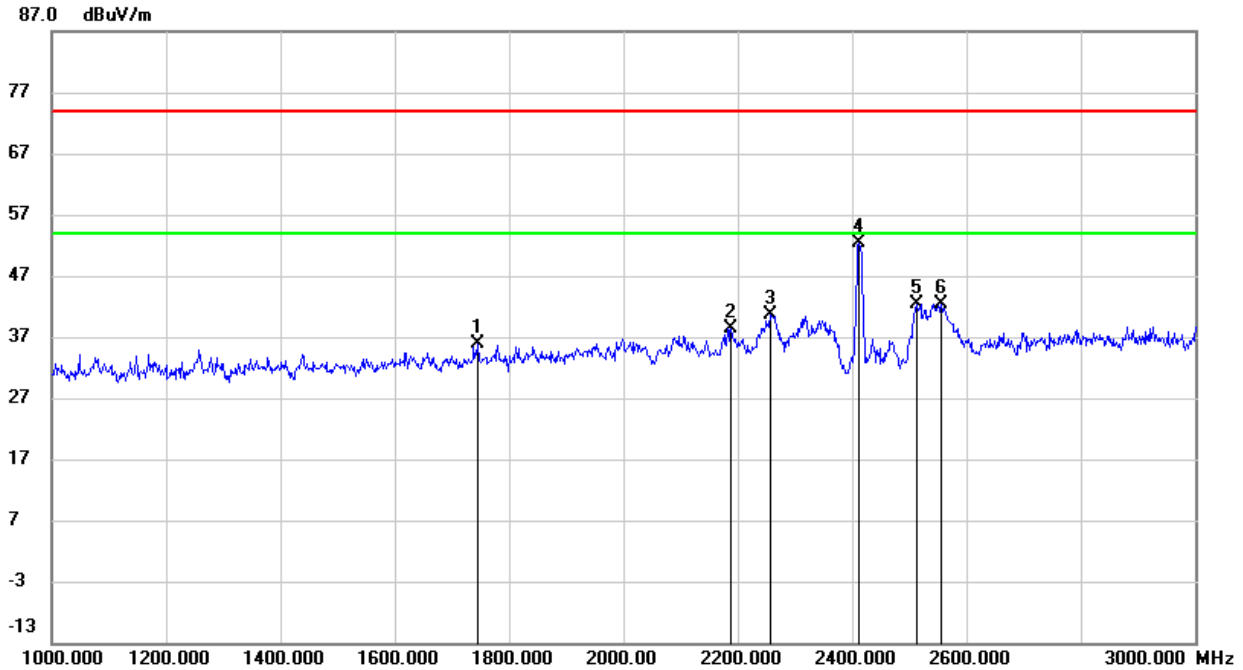

No.	Frequency (MHz)	Reading (dBuV)	Correct (dB/m)	Result (dBuV/m)	Limit (dBuV/m)	Margin (dB)	Remark
1	1746.000	46.21	-10.45	35.76	74.00	-38.24	peak
2	2188.000	47.07	-8.72	38.35	74.00	-35.65	peak
3	2256.000	49.14	-8.40	40.74	74.00	-33.26	peak
4	2412.000	60.09	-7.77	52.32	/	/	fundamental
5	2514.000	49.67	-7.24	42.43	74.00	-31.57	peak
6	2556.000	49.83	-7.47	42.36	74.00	-31.64	peak

- Note: 1. Measurement = Reading Level + Correct Factor.
 2. If Peak Result complies with AV limit, AV Result is deemed to comply with AV limit.
 3. Peak: Peak detector.
 4. Filter losses were only considered in the spurious frequency bands and the authorized band was not corrected for Band Reject Filter losses.
 5. Proper operation of the transmitter prior to adding the filter to the measurement chain.



HARMONICS AND SPURIOUS EMISSIONS (CHANNEL 2, HORIZONTAL)

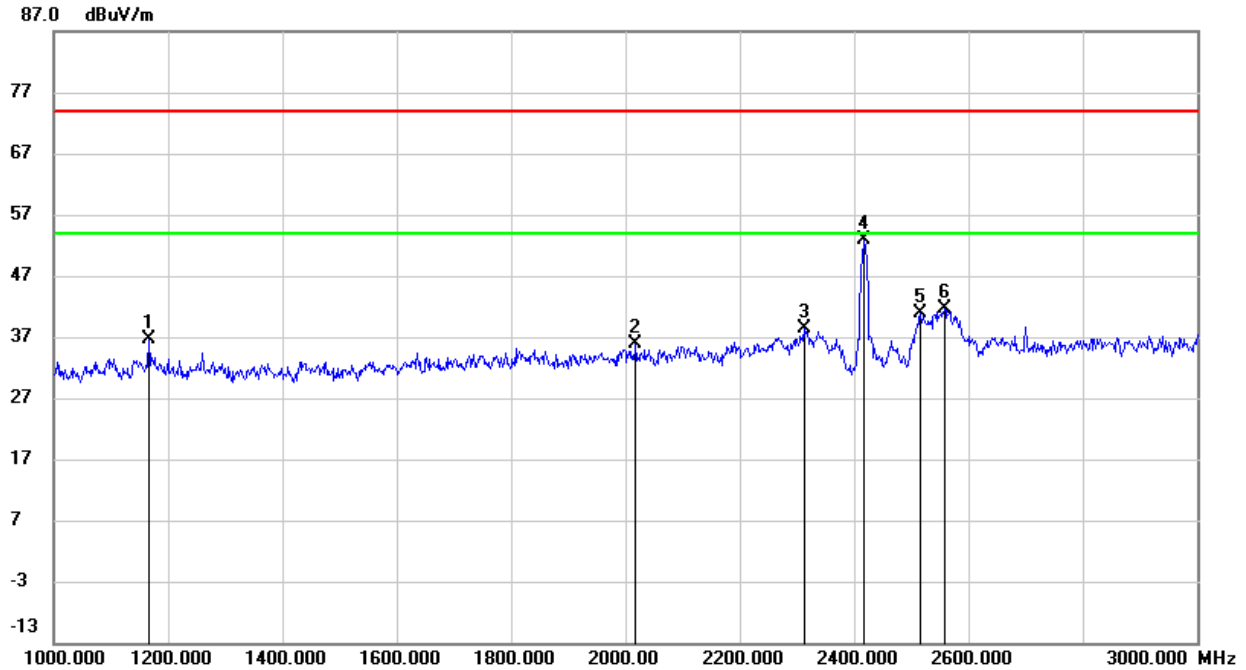

No.	Frequency (MHz)	Reading (dBuV)	Correct (dB/m)	Result (dBuV/m)	Limit (dBuV/m)	Margin (dB)	Remark
1	1166.000	49.55	-12.96	36.59	74.00	-37.41	peak
2	2018.000	45.52	-9.70	35.82	74.00	-38.18	peak
3	2312.000	46.56	-8.15	38.41	74.00	-35.59	peak
4	2417.000	60.66	-7.74	52.92	/	/	fundamental
5	2516.000	48.17	-7.25	40.92	74.00	-33.08	peak
6	2558.000	48.98	-7.47	41.51	74.00	-32.49	peak

- Note: 1. Measurement = Reading Level + Correct Factor.
 2. If Peak Result complies with AV limit, AV Result is deemed to comply with AV limit.
 3. Peak: Peak detector.
 4. Filter losses were only considered in the spurious frequency bands and the authorized band was not corrected for Band Reject Filter losses.
 5. Proper operation of the transmitter prior to adding the filter to the measurement chain.



HARMONICS AND SPURIOUS EMISSIONS (CHANNEL 2, VERTICAL)

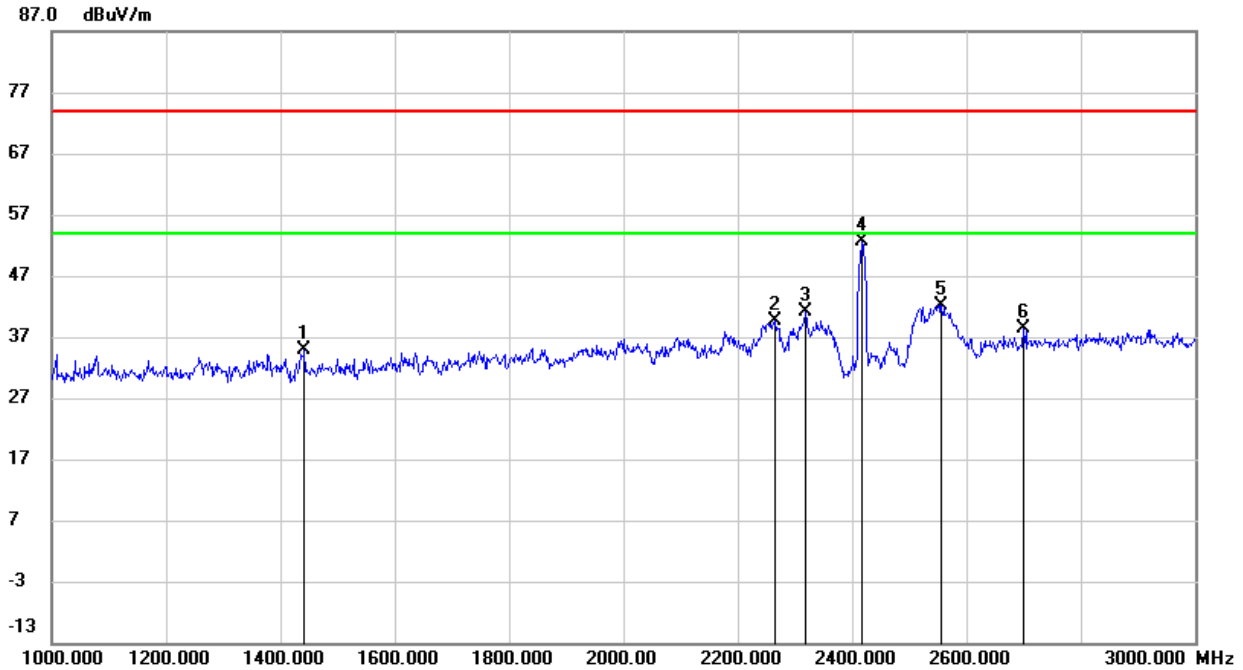

No.	Frequency (MHz)	Reading (dBuV)	Correct (dB/m)	Result (dBuV/m)	Limit (dBuV/m)	Margin (dB)	Remark
1	1442.000	47.08	-12.31	34.77	74.00	-39.23	peak
2	2266.000	48.02	-8.35	39.67	74.00	-34.33	peak
3	2318.000	49.23	-8.13	41.10	74.00	-32.90	peak
4	2417.000	60.40	-7.74	52.66	/	/	fundamental
5	2556.000	49.66	-7.47	42.19	74.00	-31.81	peak
6	2700.000	45.42	-7.13	38.29	74.00	-35.71	peak

- Note: 1. Measurement = Reading Level + Correct Factor.
 2. If Peak Result complies with AV limit, AV Result is deemed to comply with AV limit.
 3. Peak: Peak detector.
 4. Filter losses were only considered in the spurious frequency bands and the authorized band was not corrected for Band Reject Filter losses.
 5. Proper operation of the transmitter prior to adding the filter to the measurement chain.



HARMONICS AND SPURIOUS EMISSIONS (CHANNEL 6, HORIZONTAL)

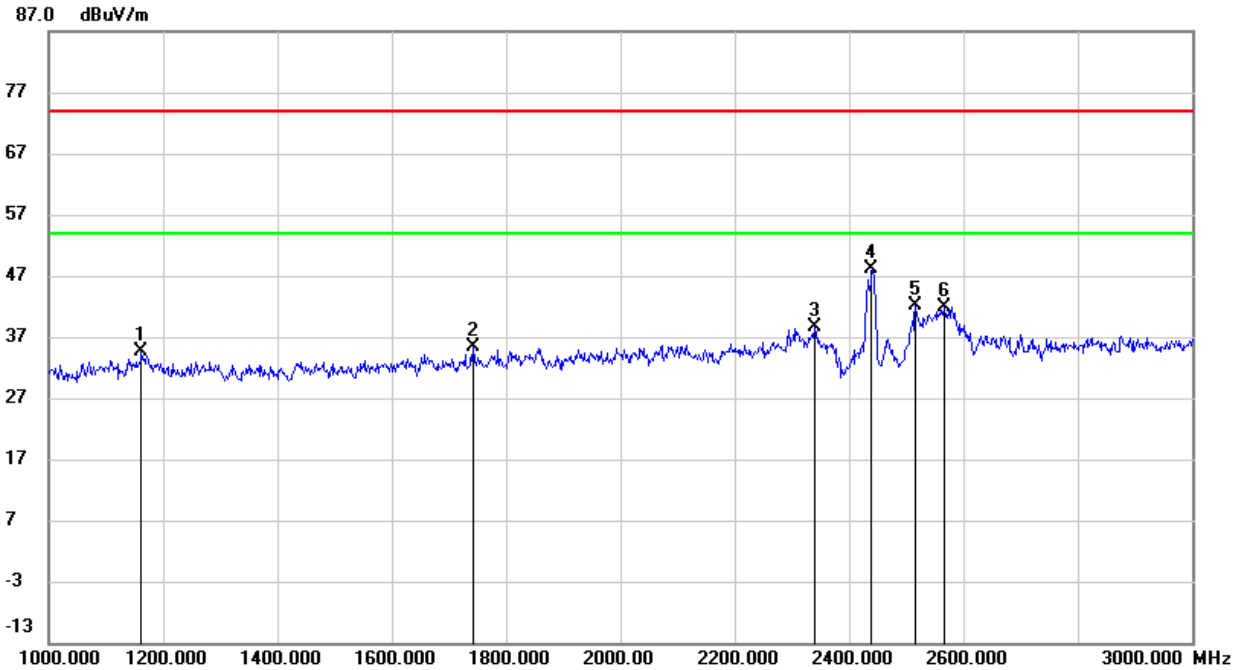

No.	Frequency (MHz)	Reading (dBuV)	Correct (dB/m)	Result (dBuV/m)	Limit (dBuV/m)	Margin (dB)	Remark
1	1162.000	47.63	-13.00	34.63	74.00	-39.37	peak
2	1742.000	45.98	-10.49	35.49	74.00	-38.51	peak
3	2340.000	46.61	-8.06	38.55	74.00	-35.45	peak
4	2437.000	55.84	-7.60	48.24	/	/	fundamental
5	2516.000	49.26	-7.25	42.01	74.00	-31.99	peak
6	2566.000	49.51	-7.52	41.99	74.00	-32.01	peak

- Note: 1. Measurement = Reading Level + Correct Factor.
 2. If Peak Result complies with AV limit, AV Result is deemed to comply with AV limit.
 3. Peak: Peak detector.
 4. Filter losses were only considered in the spurious frequency bands and the authorized band was not corrected for Band Reject Filter losses.
 5. Proper operation of the transmitter prior to adding the filter to the measurement chain.



HARMONICS AND SPURIOUS EMISSIONS (CHANNEL 6, VERTICAL)

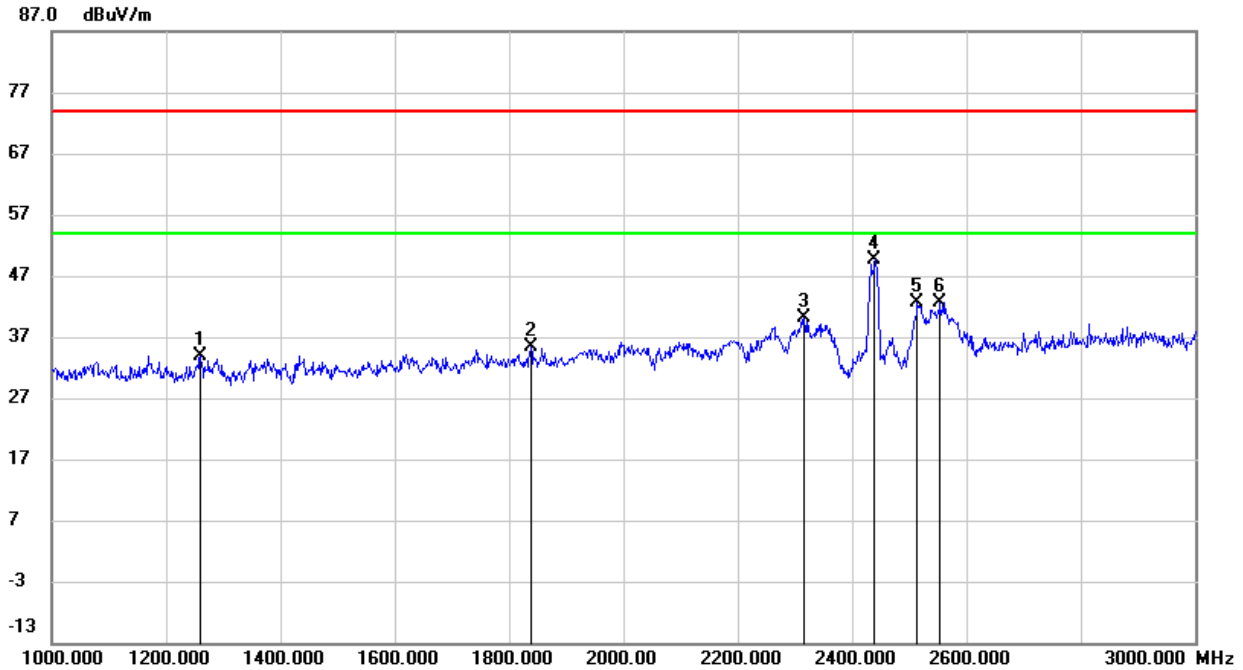

No.	Frequency (MHz)	Reading (dBuV)	Correct (dB/m)	Result (dBuV/m)	Limit (dBuV/m)	Margin (dB)	Remark
1	1260.000	46.34	-12.48	33.86	74.00	-40.14	peak
2	1838.000	45.25	-9.93	35.32	74.00	-38.68	peak
3	2316.000	48.16	-8.13	40.03	74.00	-33.97	peak
4	2437.000	57.22	-7.60	49.62	/	/	fundamental
5	2514.000	49.95	-7.24	42.71	74.00	-31.29	peak
6	2554.000	50.20	-7.46	42.74	74.00	-31.26	peak

- Note: 1. Measurement = Reading Level + Correct Factor.
 2. If Peak Result complies with AV limit, AV Result is deemed to comply with AV limit.
 3. Peak: Peak detector.
 4. Filter losses were only considered in the spurious frequency bands and the authorized band was not corrected for Band Reject Filter losses.
 5. Proper operation of the transmitter prior to adding the filter to the measurement chain.



HARMONICS AND SPURIOUS EMISSIONS (CHANNEL 10, HORIZONTAL)

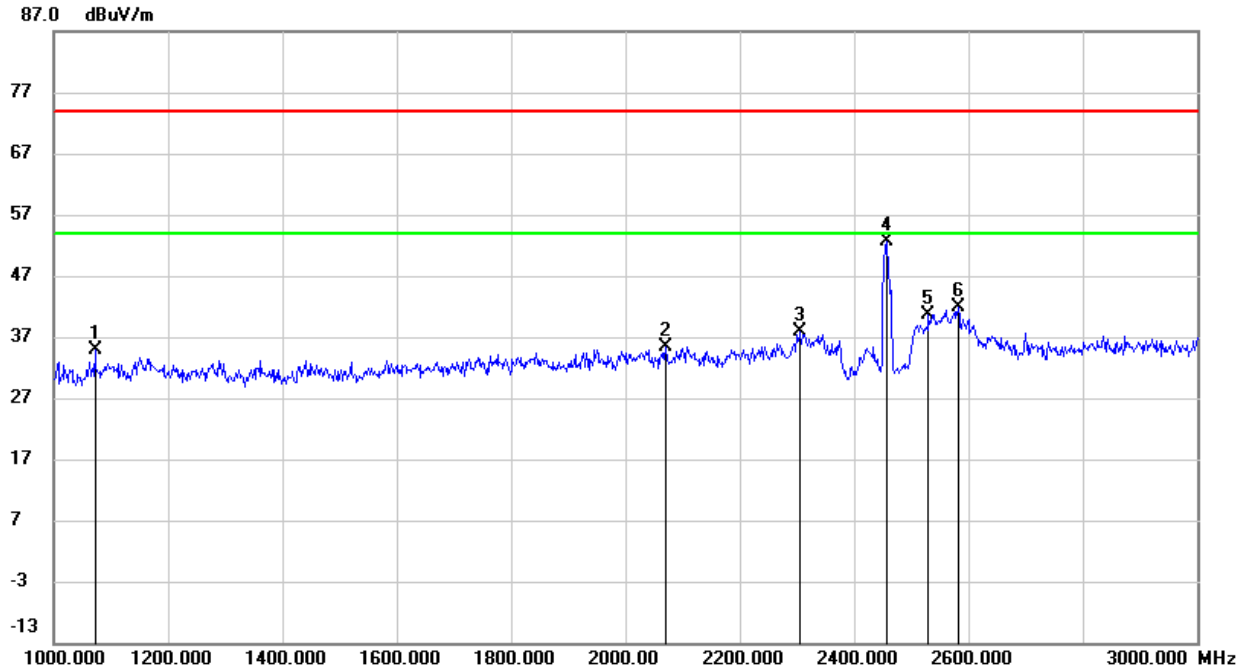

No.	Frequency (MHz)	Reading (dBuV)	Correct (dB/m)	Result (dBuV/m)	Limit (dBuV/m)	Margin (dB)	Remark
1	1072.000	48.32	-13.53	34.79	74.00	-39.21	peak
2	2070.000	44.79	-9.35	35.44	74.00	-38.56	peak
3	2306.000	45.99	-8.17	37.82	74.00	-36.18	peak
4	2457.000	60.17	-7.47	52.70	/	/	fundamental
5	2530.000	48.06	-7.32	40.74	74.00	-33.26	peak
6	2582.000	49.48	-7.60	41.88	74.00	-32.12	peak

- Note: 1. Measurement = Reading Level + Correct Factor.
 2. If Peak Result complies with AV limit, AV Result is deemed to comply with AV limit.
 3. Peak: Peak detector.
 4. Filter losses were only considered in the spurious frequency bands and the authorized band was not corrected for Band Reject Filter losses.
 5. Proper operation of the transmitter prior to adding the filter to the measurement chain.



HARMONICS AND SPURIOUS EMISSIONS (CHANNEL 10, VERTICAL)

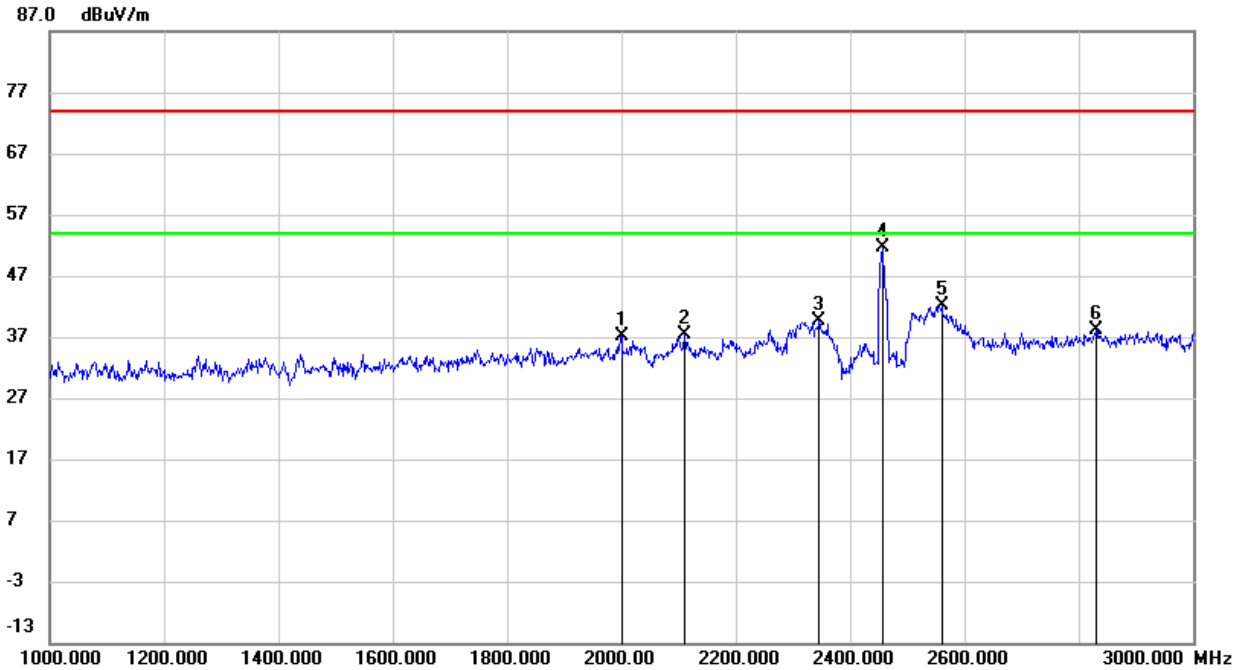

No.	Frequency (MHz)	Reading (dBuV)	Correct (dB/m)	Result (dBuV/m)	Limit (dBuV/m)	Margin (dB)	Remark
1	2000.000	47.02	-9.82	37.20	74.00	-36.80	peak
2	2110.000	46.39	-9.10	37.29	74.00	-36.71	peak
3	2346.000	47.57	-8.04	39.53	74.00	-34.47	peak
4	2457.000	59.01	-7.47	51.54	/	/	fundamental
5	2560.000	49.72	-7.48	42.24	74.00	-31.76	peak
6	2830.000	43.95	-5.89	38.06	74.00	-35.94	peak

- Note: 1. Measurement = Reading Level + Correct Factor.
 2. If Peak Result complies with AV limit, AV Result is deemed to comply with AV limit.
 3. Peak: Peak detector.
 4. Filter losses were only considered in the spurious frequency bands and the authorized band was not corrected for Band Reject Filter losses.
 5. Proper operation of the transmitter prior to adding the filter to the measurement chain.



HARMONICS AND SPURIOUS EMISSIONS (CHANNEL 11, HORIZONTAL)

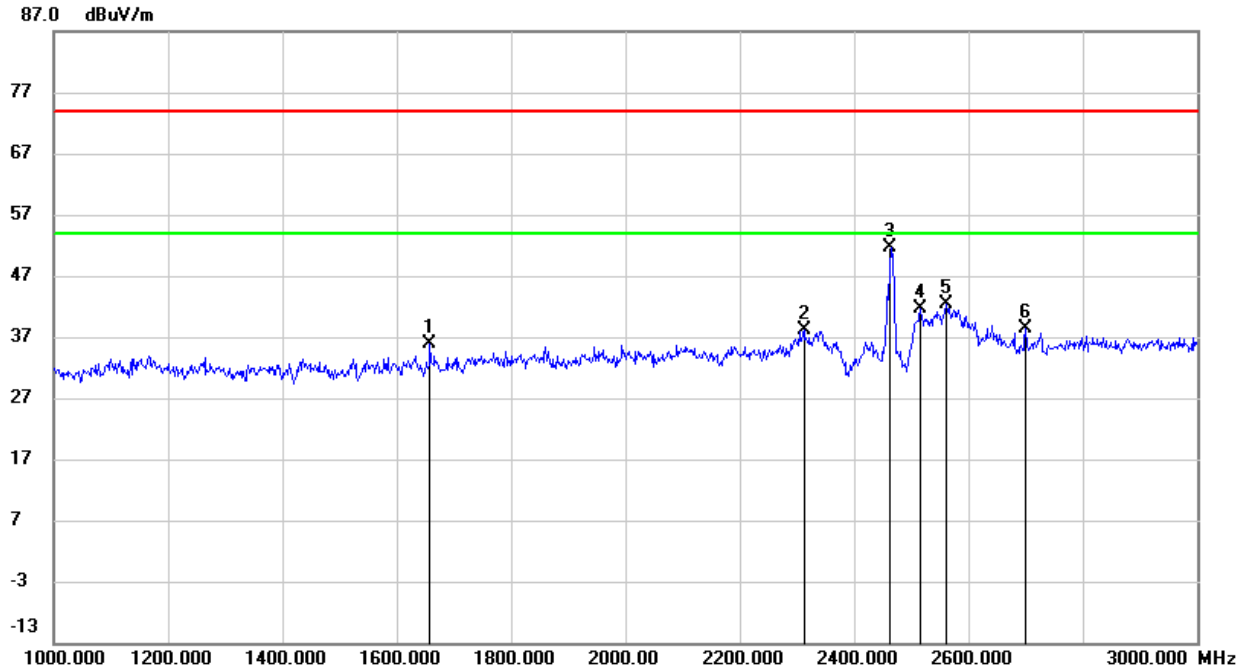

No.	Frequency (MHz)	Reading (dBuV)	Correct (dB/m)	Result (dBuV/m)	Limit (dBuV/m)	Margin (dB)	Remark
1	1658.000	46.96	-11.11	35.85	74.00	-38.15	peak
2	2312.000	46.28	-8.15	38.13	74.00	-35.87	peak
3	2462.000	58.98	-7.43	51.55	/	/	fundamental
4	2516.000	48.82	-7.25	41.57	74.00	-32.43	peak
5	2562.000	49.90	-7.50	42.40	74.00	-31.60	peak
6	2700.000	45.52	-7.13	38.39	74.00	-35.61	peak

- Note: 1. Measurement = Reading Level + Correct Factor.
 2. If Peak Result complies with AV limit, AV Result is deemed to comply with AV limit.
 3. Peak: Peak detector.
 4. Filter losses were only considered in the spurious frequency bands and the authorized band was not corrected for Band Reject Filter losses.
 5. Proper operation of the transmitter prior to adding the filter to the measurement chain.



HARMONICS AND SPURIOUS EMISSIONS (CHANNEL 11, VERTICAL)

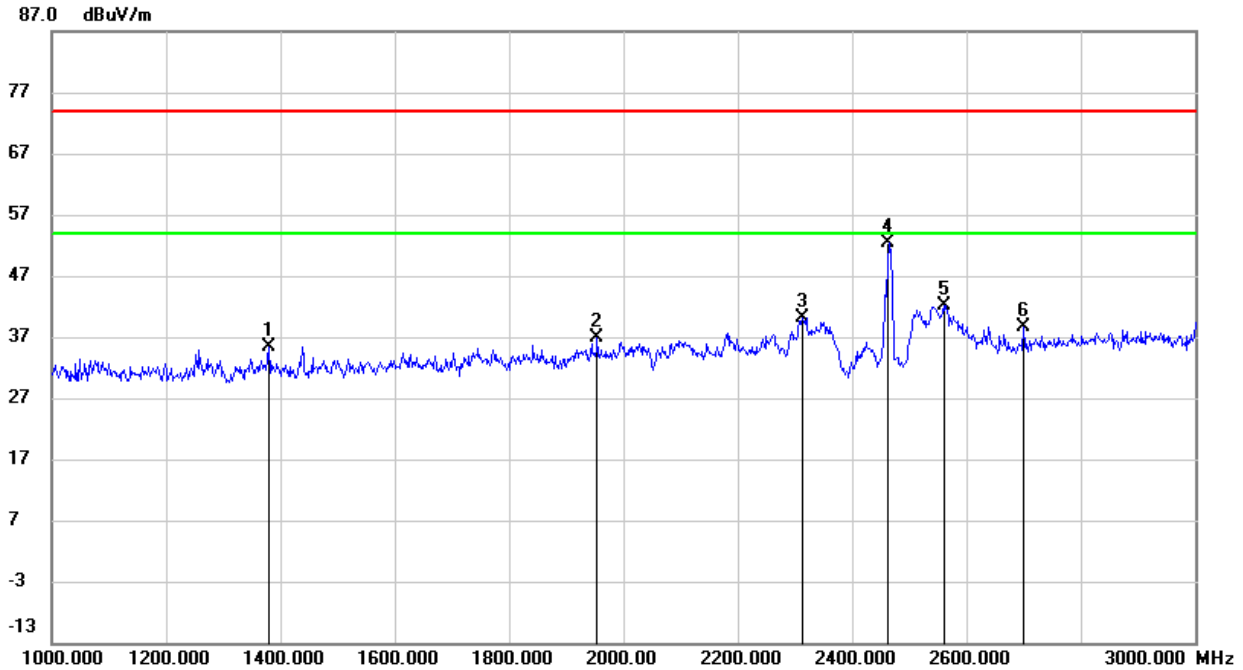

No.	Frequency (MHz)	Reading (dBuV)	Correct (dB/m)	Result (dBuV/m)	Limit (dBuV/m)	Margin (dB)	Remark
1	1380.000	47.77	-12.38	35.39	74.00	-38.61	peak
2	1954.000	46.84	-9.87	36.97	74.00	-37.03	peak
3	2314.000	48.39	-8.14	40.25	74.00	-33.75	peak
4	2462.000	59.77	-7.43	52.34	/	/	fundamental
5	2560.000	49.64	-7.48	42.16	74.00	-31.84	peak
6	2700.000	45.77	-7.13	38.64	74.00	-35.36	peak

- Note: 1. Measurement = Reading Level + Correct Factor.
 2. If Peak Result complies with AV limit, AV Result is deemed to comply with AV limit.
 3. Peak: Peak detector.
 4. Filter losses were only considered in the spurious frequency bands and the authorized band was not corrected for Band Reject Filter losses.
 5. Proper operation of the transmitter prior to adding the filter to the measurement chain.



8.3.2. 802.11g MODE

HARMONICS AND SPURIOUS EMISSIONS (CHANNEL 1, HORIZONTAL)

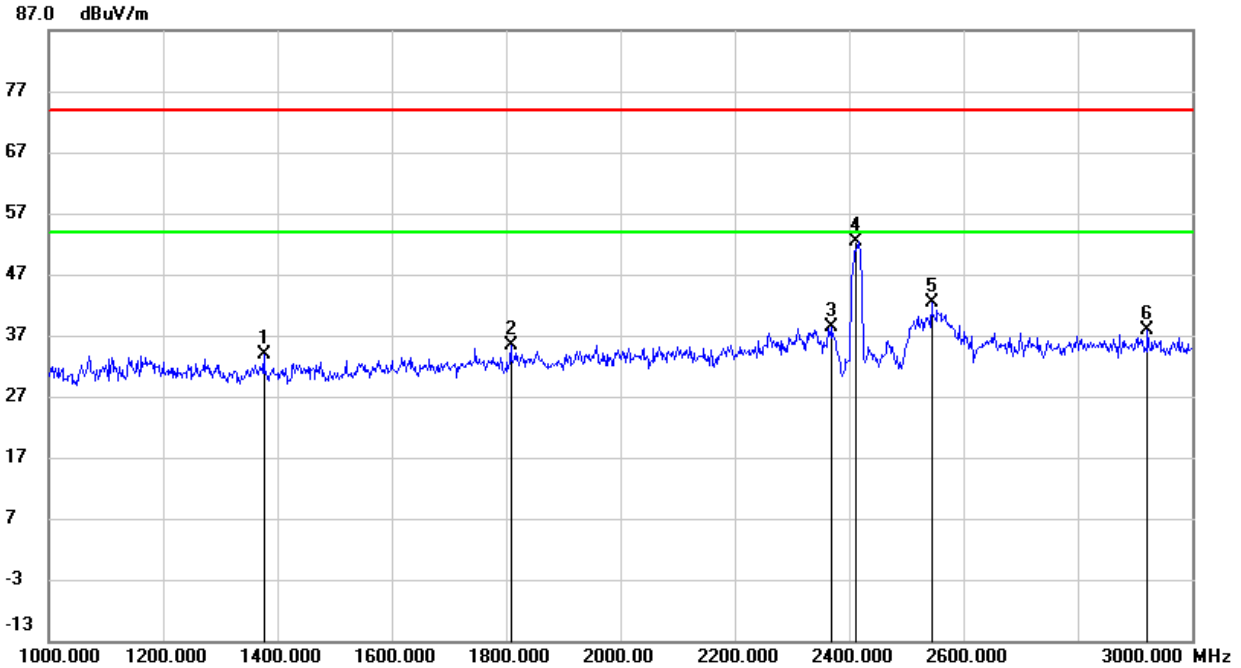

No.	Frequency (MHz)	Reading (dBuV)	Correct (dB/m)	Result (dBuV/m)	Limit (dBuV/m)	Margin (dB)	Remark
1	1376.000	46.26	-12.37	33.89	74.00	-40.11	peak
2	1808.000	45.34	-9.92	35.42	74.00	-38.58	peak
3	2370.000	46.36	-7.95	38.41	74.00	-35.59	peak
4	2412.000	60.25	-7.77	52.48	/	/	fundamental
5	2544.000	49.70	-7.40	42.30	74.00	-31.70	peak
6	2922.000	43.41	-5.47	37.94	74.00	-36.06	peak

- Note: 1. Measurement = Reading Level + Correct Factor.
 2. If Peak Result complies with AV limit, AV Result is deemed to comply with AV limit.
 3. Peak: Peak detector.
 4. Filter losses were only considered in the spurious frequency bands and the authorized band was not corrected for Band Reject Filter losses.
 5. Proper operation of the transmitter prior to adding the filter to the measurement chain.



HARMONICS AND SPURIOUS EMISSIONS (CHANNEL 1, VERTICAL)

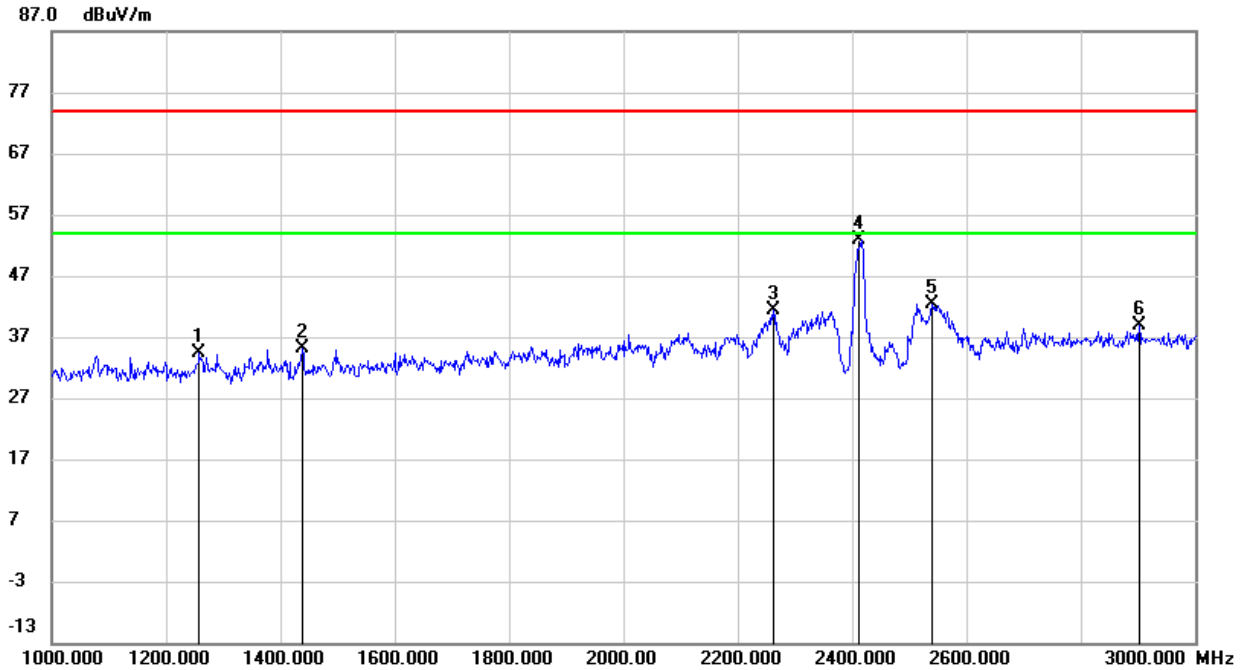

No.	Frequency (MHz)	Reading (dBuV)	Correct (dB/m)	Result (dBuV/m)	Limit (dBuV/m)	Margin (dB)	Remark
1	1258.000	46.78	-12.49	34.29	74.00	-39.71	peak
2	1438.000	47.33	-12.32	35.01	74.00	-38.99	peak
3	2262.000	49.75	-8.37	41.38	74.00	-32.62	peak
4	2412.000	60.75	-7.77	52.98	/	/	fundamental
5	2540.000	49.84	-7.38	42.46	74.00	-31.54	peak
6	2902.000	44.41	-5.51	38.90	74.00	-35.10	peak

- Note: 1. Measurement = Reading Level + Correct Factor.
 2. If Peak Result complies with AV limit, AV Result is deemed to comply with AV limit.
 3. Peak: Peak detector.
 4. Filter losses were only considered in the spurious frequency bands and the authorized band was not corrected for Band Reject Filter losses.
 5. Proper operation of the transmitter prior to adding the filter to the measurement chain.



HARMONICS AND SPURIOUS EMISSIONS (CHANNEL 2, HORIZONTAL)

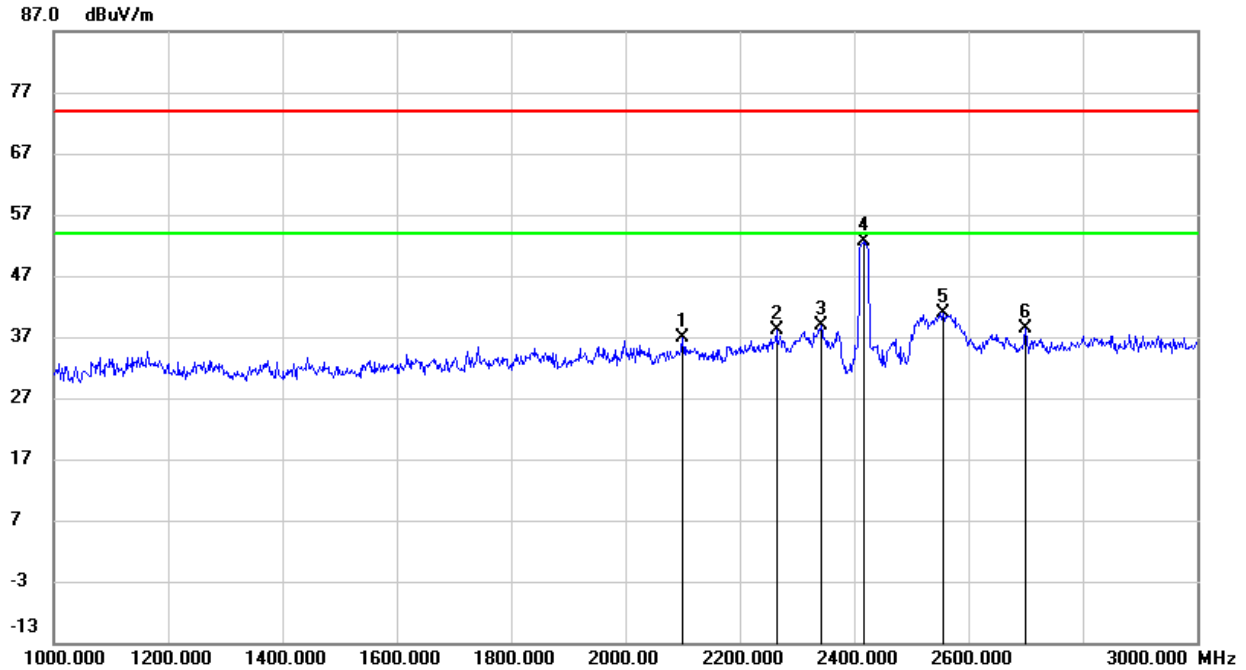

No.	Frequency (MHz)	Reading (dBuV)	Correct (dB/m)	Result (dBuV/m)	Limit (dBuV/m)	Margin (dB)	Remark
1	2100.000	46.02	-9.16	36.86	74.00	-37.14	peak
2	2264.000	46.48	-8.36	38.12	74.00	-35.88	peak
3	2342.000	47.04	-8.05	38.99	74.00	-35.01	peak
4	2417.000	60.30	-7.74	52.56	/	/	fundamental
5	2556.000	48.47	-7.47	41.00	74.00	-33.00	peak
6	2700.000	45.52	-7.13	38.39	74.00	-35.61	peak

- Note: 1. Measurement = Reading Level + Correct Factor.
 2. If Peak Result complies with AV limit, AV Result is deemed to comply with AV limit.
 3. Peak: Peak detector.
 4. Filter losses were only considered in the spurious frequency bands and the authorized band was not corrected for Band Reject Filter losses.
 5. Proper operation of the transmitter prior to adding the filter to the measurement chain.



HARMONICS AND SPURIOUS EMISSIONS (CHANNEL 2, VERTICAL)

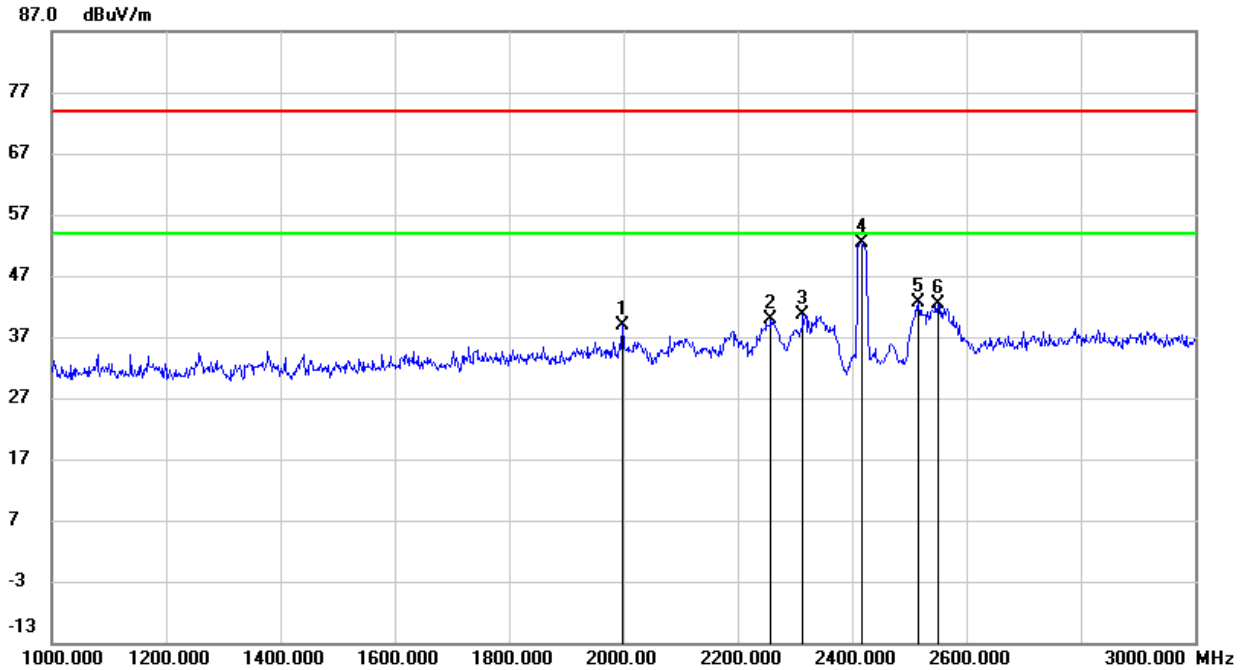

No.	Frequency (MHz)	Reading (dBuV)	Correct (dB/m)	Result (dBuV/m)	Limit (dBuV/m)	Margin (dB)	Remark
1	1998.000	48.83	-9.83	39.00	74.00	-35.00	peak
2	2258.000	48.22	-8.39	39.83	74.00	-34.17	peak
3	2314.000	48.72	-8.14	40.58	74.00	-33.42	peak
4	2417.000	60.06	-7.74	52.32	/	/	fundamental
5	2516.000	49.87	-7.25	42.62	74.00	-31.38	peak
6	2550.000	49.86	-7.44	42.42	74.00	-31.58	peak

- Note: 1. Measurement = Reading Level + Correct Factor.
 2. If Peak Result complies with AV limit, AV Result is deemed to comply with AV limit.
 3. Peak: Peak detector.
 4. Filter losses were only considered in the spurious frequency bands and the authorized band was not corrected for Band Reject Filter losses.
 5. Proper operation of the transmitter prior to adding the filter to the measurement chain.



HARMONICS AND SPURIOUS EMISSIONS (CHANNEL 6 ,HORIZONTAL)

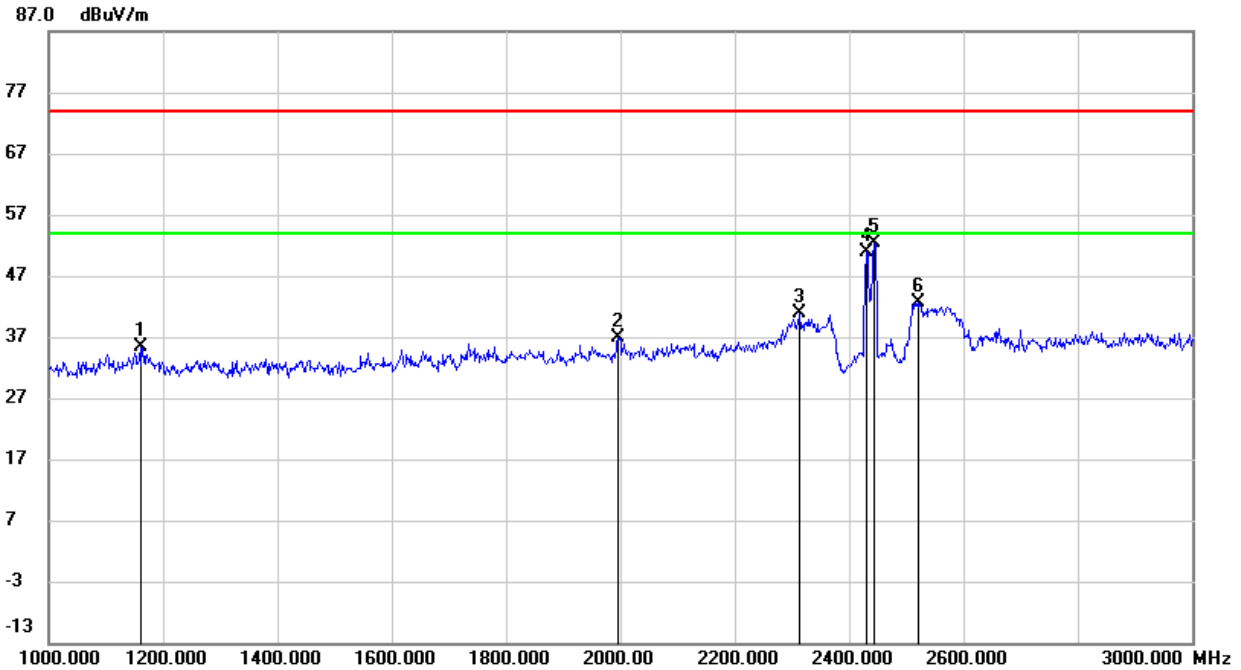

No.	Frequency (MHz)	Reading (dBuV)	Correct (dB/m)	Result (dBuV/m)	Limit (dBuV/m)	Margin (dB)	Remark
1	1160.000	48.49	-13.01	35.48	74.00	-38.52	peak
2	1996.000	46.77	-9.83	36.94	74.00	-37.06	peak
3	2314.000	49.12	-8.14	40.98	74.00	-33.02	peak
4	2437.000	58.59	-7.65	50.94	/	/	fundamental
5	2444.000	59.99	-7.55	52.44	74.00	-21.56	peak
6	2520.000	50.01	-7.27	42.74	74.00	-31.26	peak

- Note: 1. Measurement = Reading Level + Correct Factor.
2. If Peak Result complies with AV limit, AV Result is deemed to comply with AV limit.
3. Peak: Peak detector.
4. Filter losses were only considered in the spurious frequency bands and the authorized band was not corrected for Band Reject Filter losses.
5. Proper operation of the transmitter prior to adding the filter to the measurement chain.



HARMONICS AND SPURIOUS EMISSIONS (CH6 CHANNEL, VERTICAL)

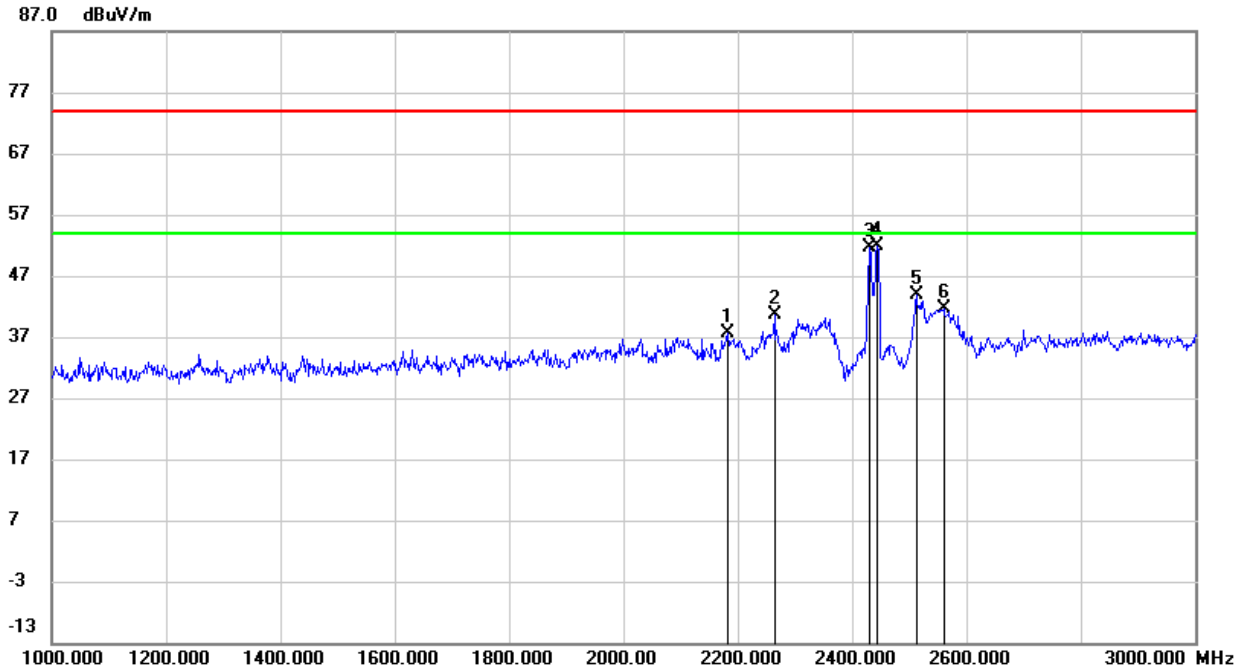

No.	Frequency (MHz)	Reading (dBuV)	Correct (dB/m)	Result (dBuV/m)	Limit (dBuV/m)	Margin (dB)	Remark
1	2182.000	46.36	-8.75	37.61	74.00	-36.39	peak
2	2264.000	48.94	-8.36	40.58	74.00	-33.42	peak
3	2437.000	59.16	-7.65	51.51	/	/	fundamental
4	2444.000	59.51	-7.55	51.96	74.00	-22.04	peak
5	2512.000	51.12	-7.23	43.89	74.00	-30.11	peak
6	2560.000	49.11	-7.48	41.63	74.00	-32.37	peak

- Note: 1. Measurement = Reading Level + Correct Factor.
 2. If Peak Result complies with AV limit, AV Result is deemed to comply with AV limit.
 3. Peak: Peak detector.
 4. Filter losses were only considered in the spurious frequency bands and the authorized band was not corrected for Band Reject Filter losses.
 5. Proper operation of the transmitter prior to adding the filter to the measurement chain.



HARMONICS AND SPURIOUS EMISSIONS (CHANNEL 10, HORIZONTAL)

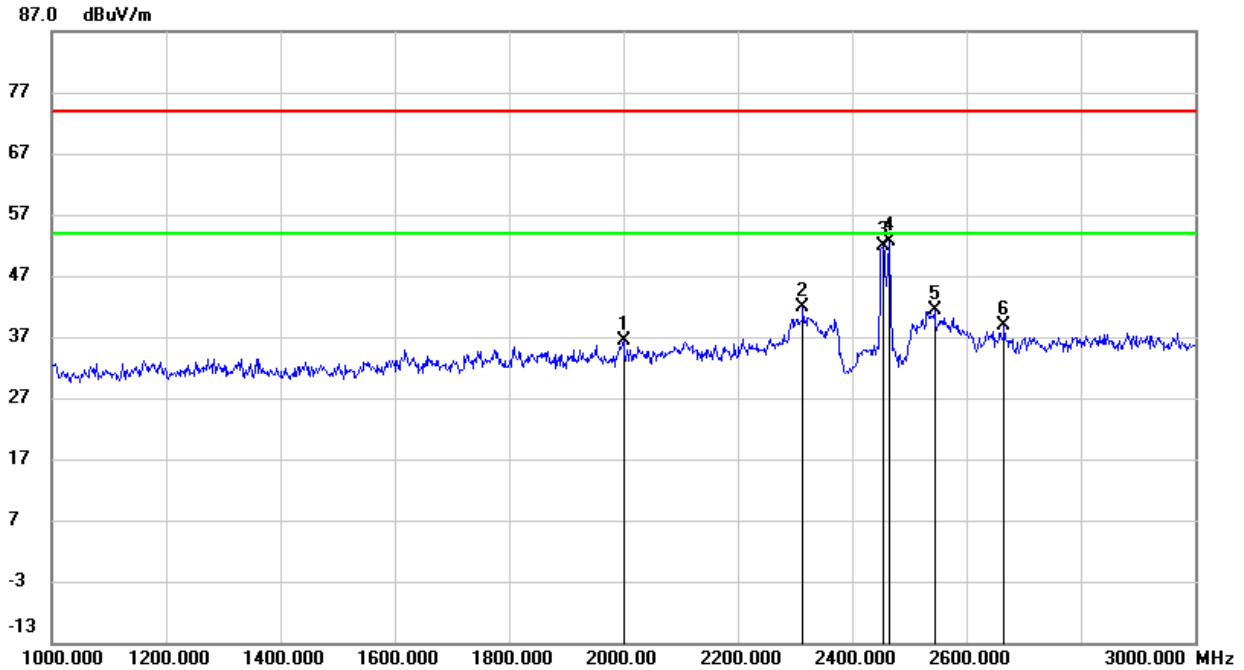

No.	Frequency (MHz)	Reading (dBuV)	Correct (dB/m)	Result (dBuV/m)	Limit (dBuV/m)	Margin (dB)	Remark
1	2000.000	46.16	-9.82	36.34	74.00	-37.66	peak
2	2314.000	49.95	-8.14	41.81	74.00	-32.19	peak
3	2457.000	59.38	-7.48	51.90	/	/	fundamental
4	2464.000	60.15	-7.41	52.74	74.00	-21.26	peak
5	2544.000	48.85	-7.40	41.45	74.00	-32.55	peak
6	2666.000	46.18	-7.32	38.86	74.00	-35.14	peak

- Note: 1. Measurement = Reading Level + Correct Factor.
 2. If Peak Result complies with AV limit, AV Result is deemed to comply with AV limit.
 3. Peak: Peak detector.
 4. Filter losses were only considered in the spurious frequency bands and the authorized band was not corrected for Band Reject Filter losses.
 5. Proper operation of the transmitter prior to adding the filter to the measurement chain.



HARMONICS AND SPURIOUS EMISSIONS (CHANNEL 10, VERTICAL)

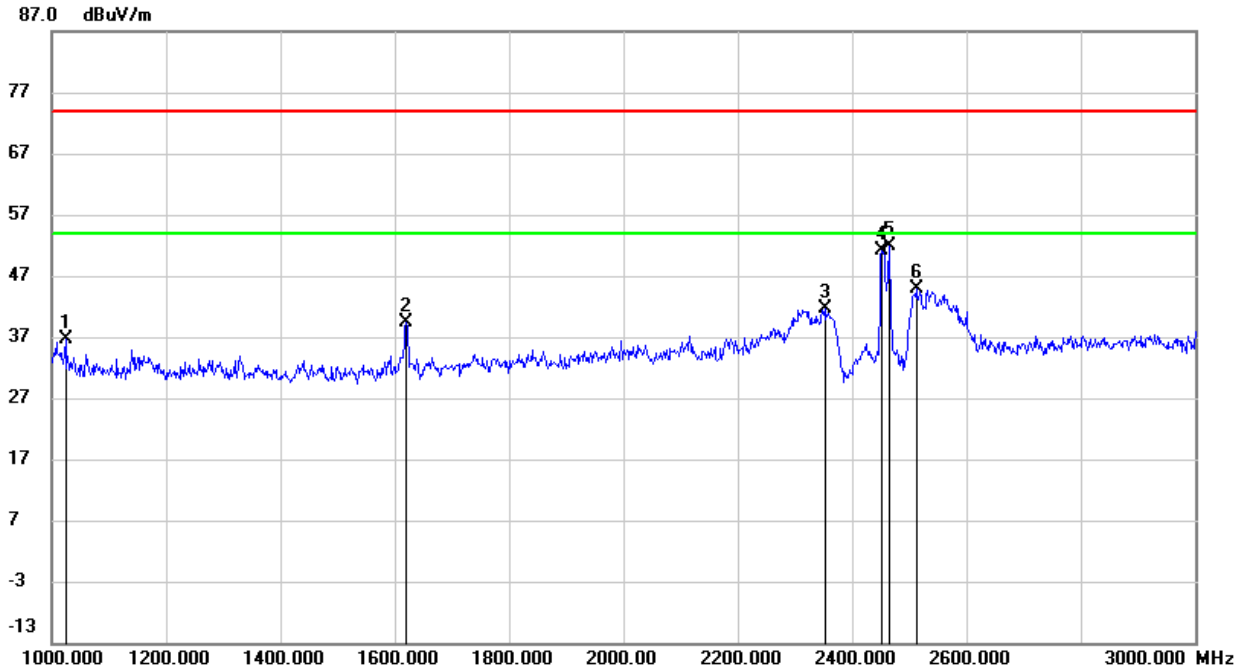

No.	Frequency (MHz)	Reading (dBuV)	Correct (dB/m)	Result (dBuV/m)	Limit (dBuV/m)	Margin (dB)	Remark
1	1024.000	50.09	-13.57	36.52	74.00	-37.48	peak
2	1620.000	50.69	-11.29	39.40	74.00	-34.60	peak
3	2352.000	49.77	-8.02	41.75	74.00	-32.25	peak
4	2457.000	58.54	-7.50	51.04	/	/	fundamental
5	2464.000	59.20	-7.41	51.79	74.00	-22.21	peak
6	2512.000	52.22	-7.23	44.99	74.00	-29.01	peak

- Note: 1. Measurement = Reading Level + Correct Factor.
 2. If Peak Result complies with AV limit, AV Result is deemed to comply with AV limit.
 3. Peak: Peak detector.
 4. Filter losses were only considered in the spurious frequency bands and the authorized band was not corrected for Band Reject Filter losses.
 5. Proper operation of the transmitter prior to adding the filter to the measurement chain.



HARMONICS AND SPURIOUS EMISSIONS (CHANNEL 11, HORIZONTAL)

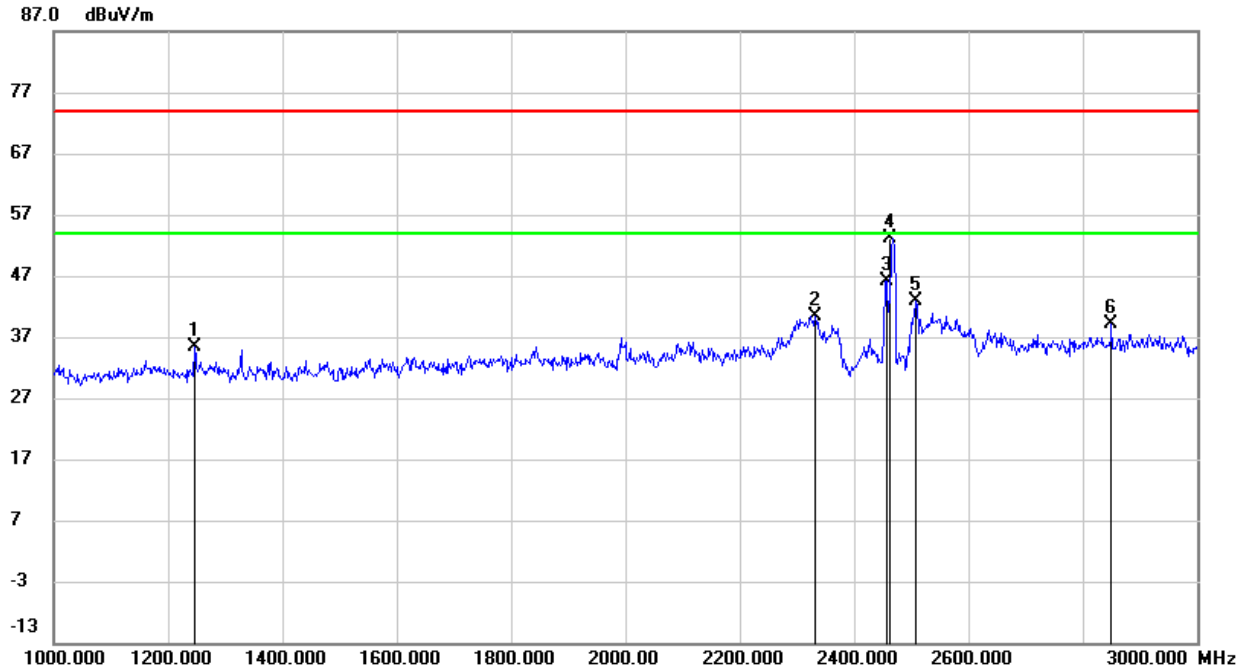

No.	Frequency (MHz)	Reading (dBuV)	Correct (dB/m)	Result (dBuV/m)	Limit (dBuV/m)	Margin (dB)	Remark
1	1246.000	47.81	-12.52	35.29	74.00	-38.71	peak
2	2332.000	48.37	-8.08	40.29	74.00	-33.71	peak
3	2456.000	53.72	-7.47	46.25	74.00	-27.75	peak
4	2462.000	60.59	-7.43	53.16	/	/	fundamental
5	2508.000	50.09	-7.21	42.88	74.00	-31.12	peak
6	2850.000	44.80	-5.79	39.01	74.00	-34.99	peak

- Note: 1. Measurement = Reading Level + Correct Factor.
 2. If Peak Result complies with AV limit, AV Result is deemed to comply with AV limit.
 3. Peak: Peak detector.
 4. Filter losses were only considered in the spurious frequency bands and the authorized band was not corrected for Band Reject Filter losses.
 5. Proper operation of the transmitter prior to adding the filter to the measurement chain.



HARMONICS AND SPURIOUS EMISSIONS (CHANNEL 11, VERTICAL)

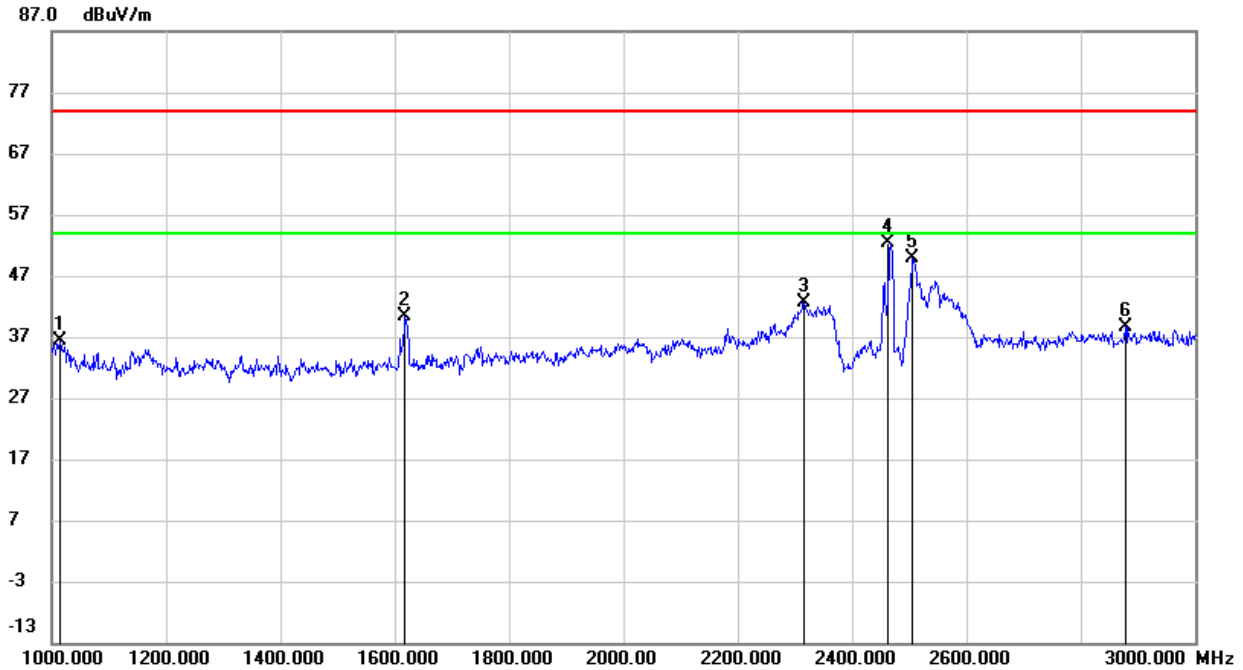

No.	Frequency (MHz)	Reading (dBuV)	Correct (dB/m)	Result (dBuV/m)	Limit (dBuV/m)	Margin (dB)	Remark
1	1014.000	49.85	-13.57	36.28	74.00	-37.72	peak
2	1618.000	51.72	-11.31	40.41	74.00	-33.59	peak
3	2316.000	50.78	-8.13	42.65	74.00	-31.35	peak
4	2462.000	59.71	-7.43	52.28	/	/	fundamental
5	2506.000	57.08	-7.20	49.88	74.00	-24.12	peak
6	2878.000	44.27	-5.64	38.63	74.00	-35.37	peak

- Note: 1. Measurement = Reading Level + Correct Factor.
 2. If Peak Result complies with AV limit, AV Result is deemed to comply with AV limit.
 3. Peak: Peak detector.
 4. Filter losses were only considered in the spurious frequency bands and the authorized band was not corrected for Band Reject Filter losses.
 5. Proper operation of the transmitter prior to adding the filter to the measurement chain.



8.3.3. 802.11n HT20 MODE

HARMONICS AND SPURIOUS EMISSIONS (CHANNEL 1, HORIZONTAL)

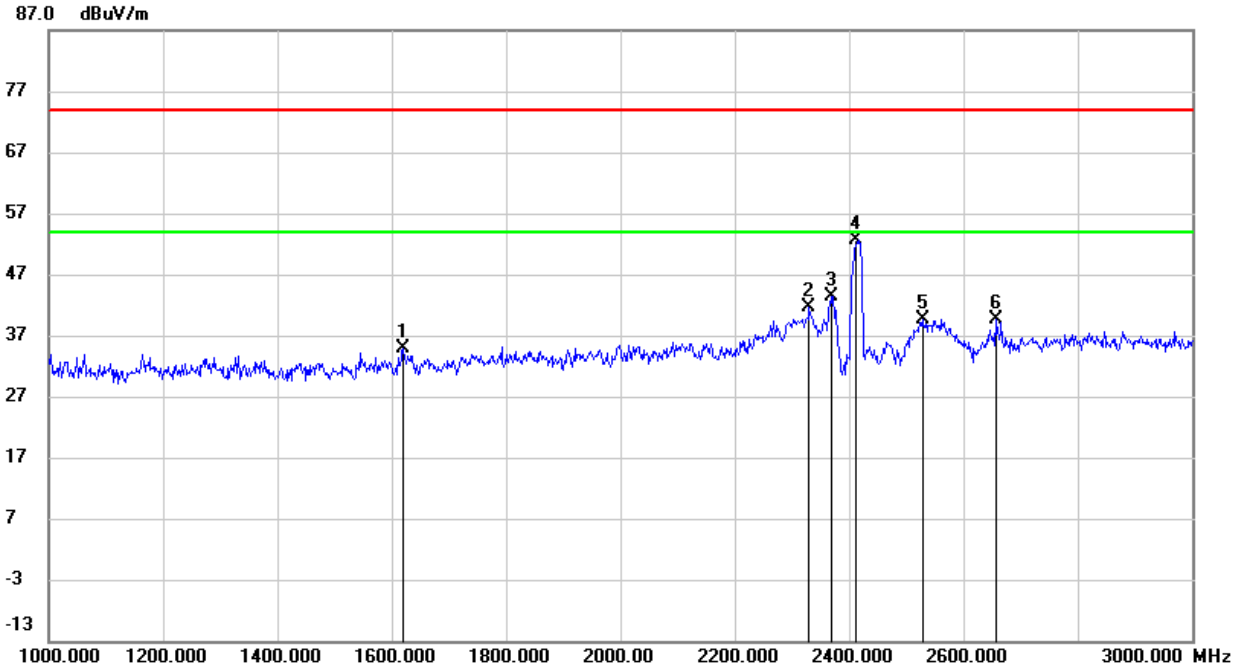

No.	Frequency (MHz)	Reading (dBuV)	Correct (dB/m)	Result (dBuV/m)	Limit (dBuV/m)	Margin (dB)	Remark
1	1620.000	46.16	-11.29	34.87	74.00	-39.13	peak
2	2330.000	49.67	-8.10	41.57	74.00	-32.43	peak
3	2370.000	51.41	-7.95	43.46	74.00	-30.54	peak
4	2412.000	60.32	-7.77	52.55	/	/	fundamental
5	2528.000	47.06	-7.32	39.74	74.00	-34.26	peak
6	2656.000	47.00	-7.38	39.62	74.00	-34.38	peak

- Note:
1. Measurement = Reading Level + Correct Factor.
 2. If Peak Result complies with AV limit, AV Result is deemed to comply with AV limit.
 3. Peak: Peak detector.
 4. Filter losses were only considered in the spurious frequency bands and the authorized band was not corrected for Band Reject Filter losses.
 5. Proper operation of the transmitter prior to adding the filter to the measurement chain.



HARMONICS AND SPURIOUS EMISSIONS (CHANNEL 1, VERTICAL)

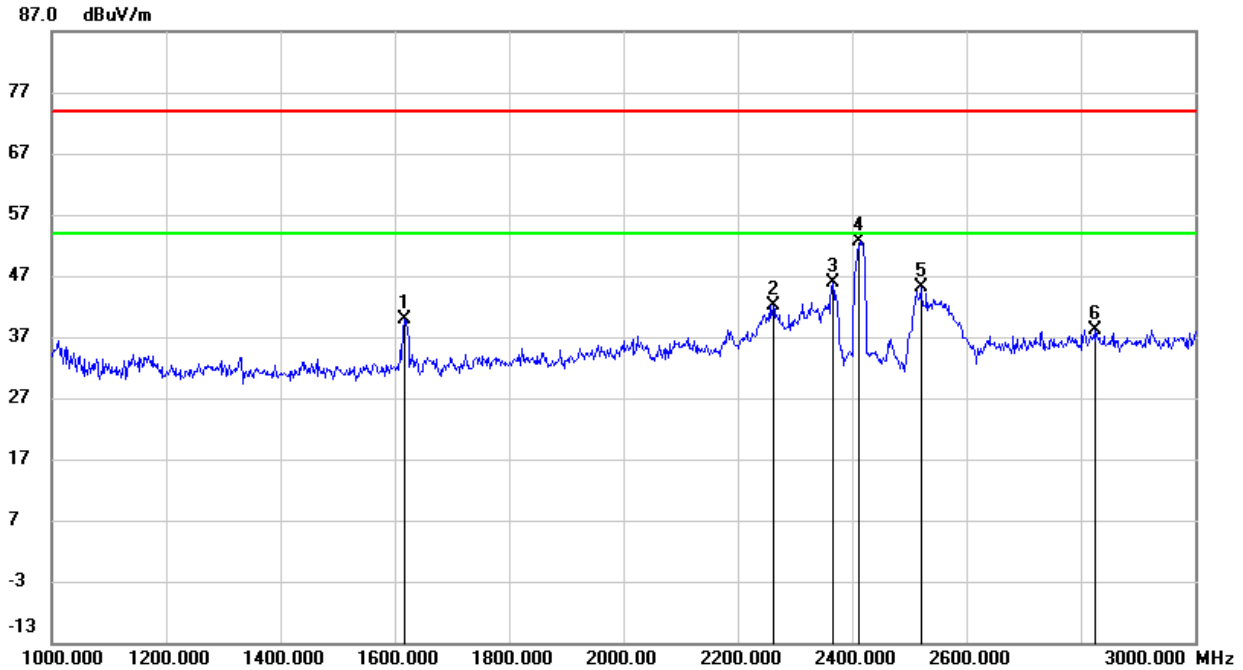

No.	Frequency (MHz)	Reading (dBuV)	Correct (dB/m)	Result (dBuV/m)	Limit (dBuV/m)	Margin (dB)	Remark
1	1618.000	51.25	-11.31	39.94	74.00	-34.06	peak
2	2262.000	50.62	-8.37	42.25	74.00	-31.75	peak
3	2366.000	53.96	-7.97	45.99	74.00	-28.01	peak
4	2412.000	60.45	-7.77	52.68	/	/	fundamental
5	2520.000	52.29	-7.27	45.02	74.00	-28.98	peak
6	2826.000	44.13	-5.92	38.21	74.00	-35.79	peak

- Note: 1. Measurement = Reading Level + Correct Factor.
 2. If Peak Result complies with AV limit, AV Result is deemed to comply with AV limit.
 3. Peak: Peak detector.
 4. Filter losses were only considered in the spurious frequency bands and the authorized band was not corrected for Band Reject Filter losses.
 5. Proper operation of the transmitter prior to adding the filter to the measurement chain.



HARMONICS AND SPURIOUS EMISSIONS (CHANNEL 2, HORIZONTAL)

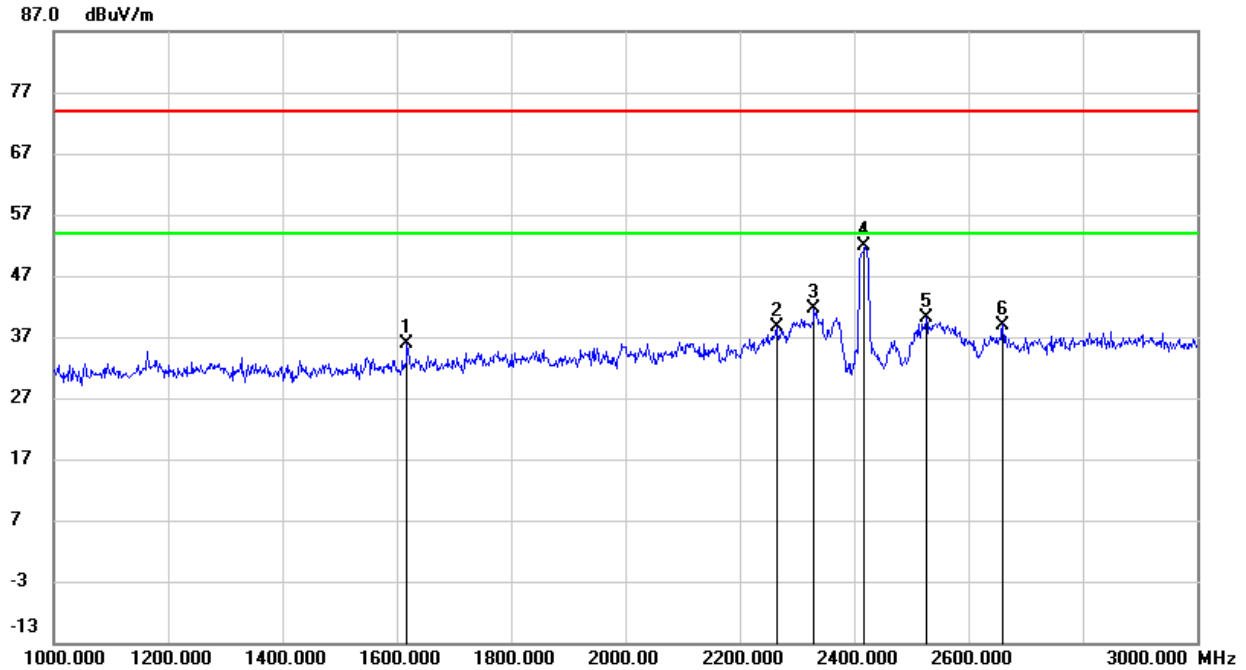

No.	Frequency (MHz)	Reading (dBuV)	Correct (dB/m)	Result (dBuV/m)	Limit (dBuV/m)	Margin (dB)	Remark
1	1618.000	47.19	-11.31	35.88	74.00	-38.12	peak
2	2264.000	47.10	-8.36	38.74	74.00	-35.26	peak
3	2330.000	49.69	-8.10	41.59	74.00	-32.41	peak
4	2417.000	59.69	-7.74	51.95	/	/	fundamental
5	2526.000	47.45	-7.31	40.14	74.00	-33.86	peak
6	2660.000	46.35	-7.35	39.00	74.00	-35.00	peak

- Note: 1. Measurement = Reading Level + Correct Factor.
 2. If Peak Result complies with AV limit, AV Result is deemed to comply with AV limit.
 3. Peak: Peak detector.
 4. Filter losses were only considered in the spurious frequency bands and the authorized band was not corrected for Band Reject Filter losses.
 5. Proper operation of the transmitter prior to adding the filter to the measurement chain.



HARMONICS AND SPURIOUS EMISSIONS (CHANNEL 2, VERTICAL)

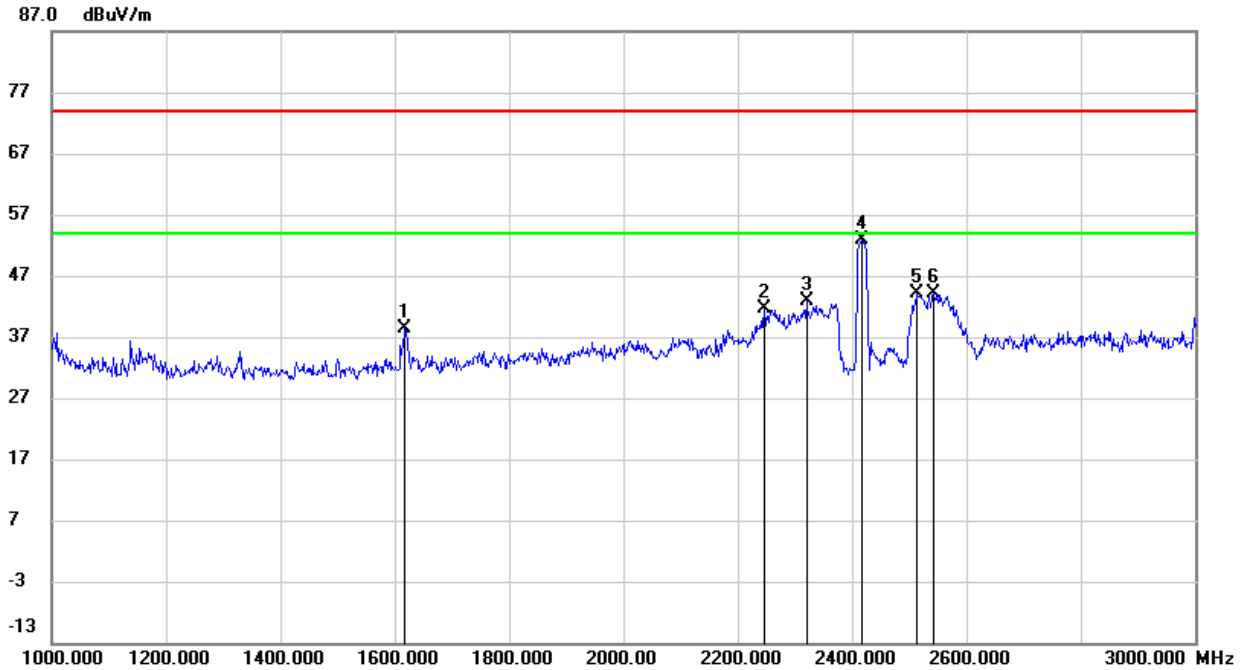

No.	Frequency (MHz)	Reading (dBuV)	Correct (dB/m)	Result (dBuV/m)	Limit (dBuV/m)	Margin (dB)	Remark
1	1618.000	49.65	-11.31	38.34	74.00	-35.66	peak
2	2246.000	50.15	-8.45	41.70	74.00	-32.30	peak
3	2320.000	50.94	-8.12	42.82	74.00	-31.18	peak
4	2417.000	60.61	-7.74	52.87	/	/	fundamental
5	2514.000	51.41	-7.24	44.17	74.00	-29.83	peak
6	2542.000	51.52	-7.39	44.13	74.00	-29.87	peak

- Note: 1. Measurement = Reading Level + Correct Factor.
 2. If Peak Result complies with AV limit, AV Result is deemed to comply with AV limit.
 3. Peak: Peak detector.
 4. Filter losses were only considered in the spurious frequency bands and the authorized band was not corrected for Band Reject Filter losses.
 5. Proper operation of the transmitter prior to adding the filter to the measurement chain.



HARMONICS AND SPURIOUS EMISSIONS (CHANNEL 6, HORIZONTAL)

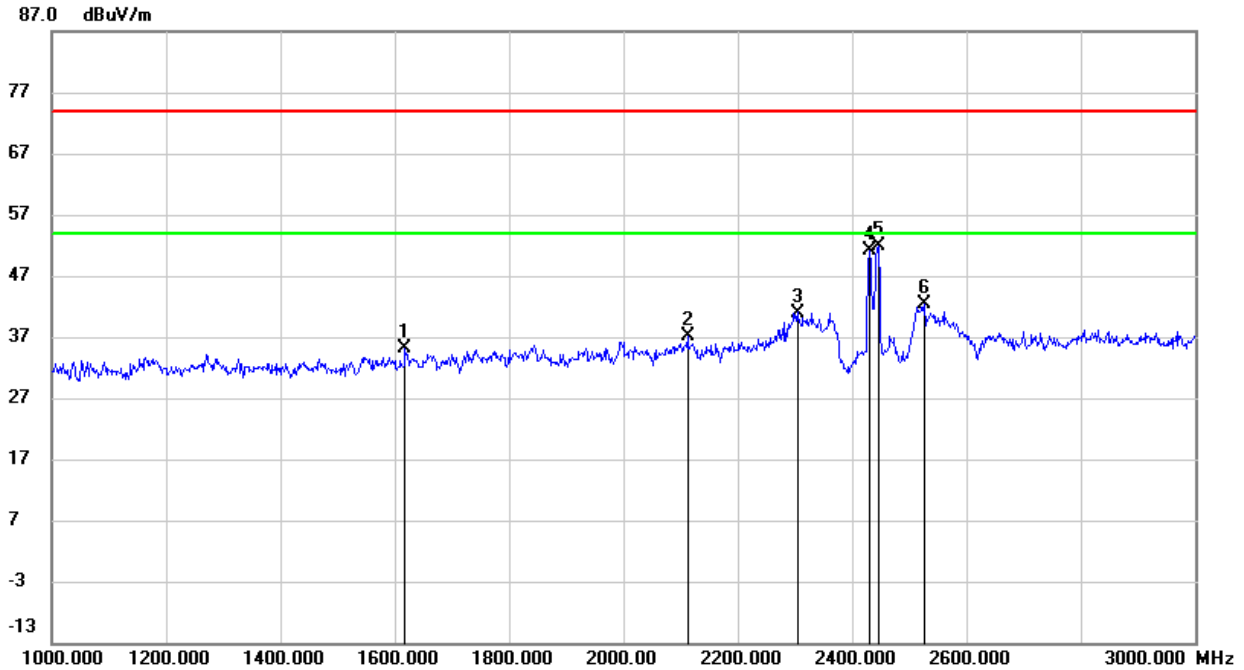

No.	Frequency (MHz)	Reading (dBuV)	Correct (dB/m)	Result (dBuV/m)	Limit (dBuV/m)	Margin (dB)	Remark
1	1618.000	46.55	-11.31	35.24	74.00	-38.76	peak
2	2112.000	46.18	-9.10	37.08	74.00	-36.92	peak
3	2304.000	49.18	-8.18	41.00	74.00	-33.00	peak
4	2437.000	58.72	-7.65	51.07	/	/	fundamental
5	2446.000	59.41	-7.54	51.87	74.00	-22.13	peak
6	2526.000	49.63	-7.31	42.32	74.00	-31.68	peak

- Note: 1. Measurement = Reading Level + Correct Factor.
 2. If Peak Result complies with AV limit, AV Result is deemed to comply with AV limit.
 3. Peak: Peak detector.
 4. Filter losses were only considered in the spurious frequency bands and the authorized band was not corrected for Band Reject Filter losses.
 5. Proper operation of the transmitter prior to adding the filter to the measurement chain.



HARMONICS AND SPURIOUS EMISSIONS (CHANNEL 6, VERTICAL)

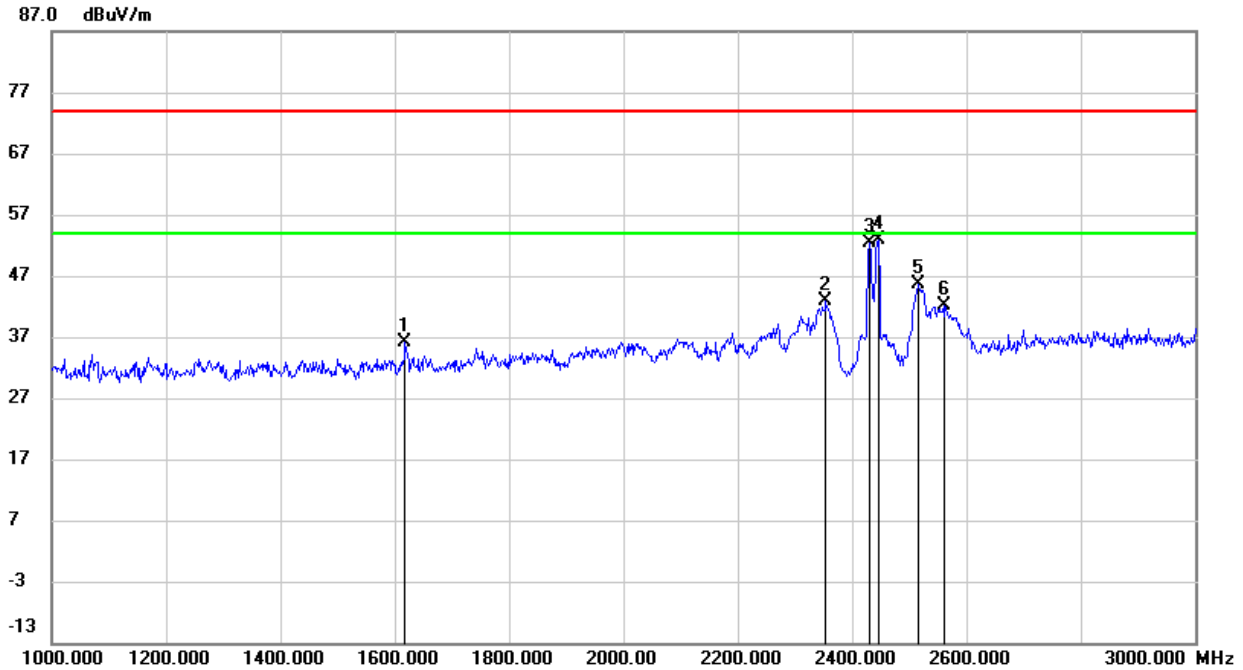

No.	Frequency (MHz)	Reading (dBuV)	Correct (dB/m)	Result (dBuV/m)	Limit (dBuV/m)	Margin (dB)	Remark
1	1618.000	47.38	-11.31	36.07	74.00	-37.93	peak
2	2354.000	50.82	-8.01	42.81	74.00	-31.19	peak
3	2437.000	59.92	-7.65	52.27	/	/	fundamental
4	2446.000	60.38	-7.54	52.84	74.00	-21.16	peak
5	2516.000	52.87	-7.25	45.62	74.00	-28.38	peak
6	2560.000	49.54	-7.48	42.06	74.00	-31.94	peak

- Note: 1. Measurement = Reading Level + Correct Factor.
 2. If Peak Result complies with AV limit, AV Result is deemed to comply with AV limit.
 3. Peak: Peak detector.
 4. Filter losses were only considered in the spurious frequency bands and the authorized band was not corrected for Band Reject Filter losses.
 5. Proper operation of the transmitter prior to adding the filter to the measurement chain.



HARMONICS AND SPURIOUS EMISSIONS (CHANNEL 10, HORIZONTAL)

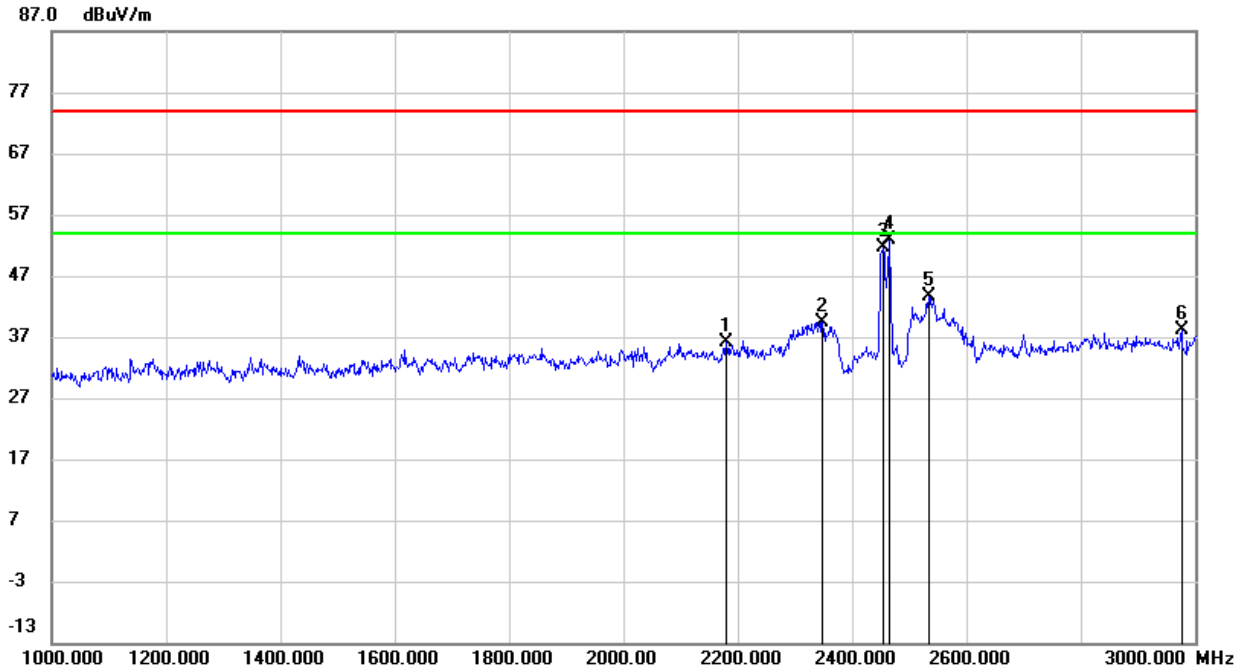

No.	Frequency (MHz)	Reading (dBuV)	Correct (dB/m)	Result (dBuV/m)	Limit (dBuV/m)	Margin (dB)	Remark
1	2180.000	44.78	-8.76	36.02	74.00	-37.98	peak
2	2348.000	47.37	-8.03	39.34	74.00	-34.66	peak
3	2452.000	59.01	-7.48	51.53	/	/	fundamental
4	2466.000	60.36	-7.40	52.96	74.00	-21.04	peak
5	2534.000	50.96	-7.35	43.61	74.00	-30.39	peak
6	2976.000	43.56	-5.35	38.21	74.00	-35.79	peak

- Note: 1. Measurement = Reading Level + Correct Factor.
 2. If Peak Result complies with AV limit, AV Result is deemed to comply with AV limit.
 3. Peak: Peak detector.
 4. Filter losses were only considered in the spurious frequency bands and the authorized band was not corrected for Band Reject Filter losses.
 5. Proper operation of the transmitter prior to adding the filter to the measurement chain.



HARMONICS AND SPURIOUS EMISSIONS (CHANNEL 10, VERTICAL)

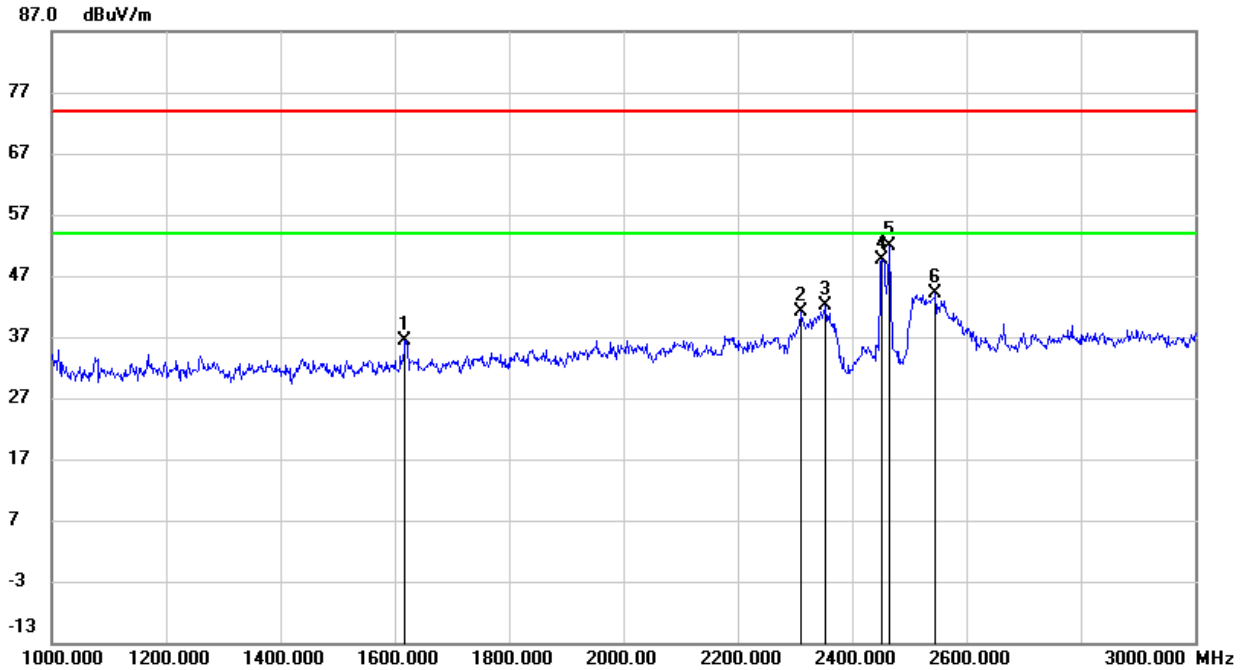

No.	Frequency (MHz)	Reading (dBuV)	Correct (dB/m)	Result (dBuV/m)	Limit (dBuV/m)	Margin (dB)	Remark
1	1618.000	47.72	-11.31	36.41	74.00	-37.59	peak
2	2310.000	49.19	-8.16	41.03	74.00	-32.97	peak
3	2354.000	50.16	-8.01	42.15	74.00	-31.85	peak
4	2452.000	57.23	-7.50	49.73	/	/	fundamental
5	2466.000	59.24	-7.40	51.84	74.00	-22.16	peak
6	2546.000	51.49	-7.41	44.08	74.00	-29.92	peak

- Note: 1. Measurement = Reading Level + Correct Factor.
 2. If Peak Result complies with AV limit, AV Result is deemed to comply with AV limit.
 3. Peak: Peak detector.
 4. Filter losses were only considered in the spurious frequency bands and the authorized band was not corrected for Band Reject Filter losses.
 5. Proper operation of the transmitter prior to adding the filter to the measurement chain.



HARMONICS AND SPURIOUS EMISSIONS (CHANNEL 11, HORIZONTAL)

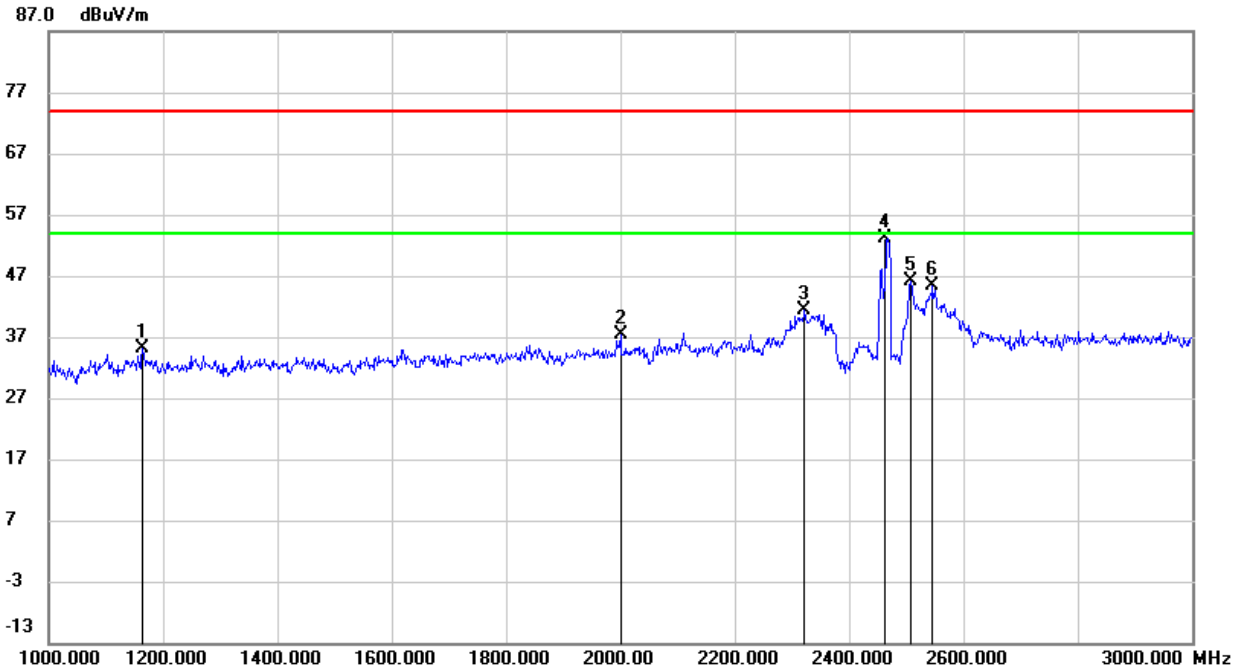

No.	Frequency (MHz)	Reading (dBuV)	Correct (dB/m)	Result (dBuV/m)	Limit (dBuV/m)	Margin (dB)	Remark
1	1164.000	48.12	-12.97	35.15	74.00	-38.85	peak
2	2000.000	47.24	-9.82	37.42	74.00	-36.58	peak
3	2322.000	49.54	-8.12	41.42	74.00	-32.58	peak
4	2462.000	60.46	-7.43	53.03	/	/	fundamental
5	2508.000	53.23	-7.21	46.02	74.00	-27.98	peak
6	2546.000	52.77	-7.41	45.36	74.00	-28.64	peak

- Note: 1. Measurement = Reading Level + Correct Factor.
 2. If Peak Result complies with AV limit, AV Result is deemed to comply with AV limit.
 3. Peak: Peak detector.
 4. Filter losses were only considered in the spurious frequency bands and the authorized band was not corrected for Band Reject Filter losses.
 5. Proper operation of the transmitter prior to adding the filter to the measurement chain.



HARMONICS AND SPURIOUS EMISSIONS (CHANNEL 11, VERTICAL)

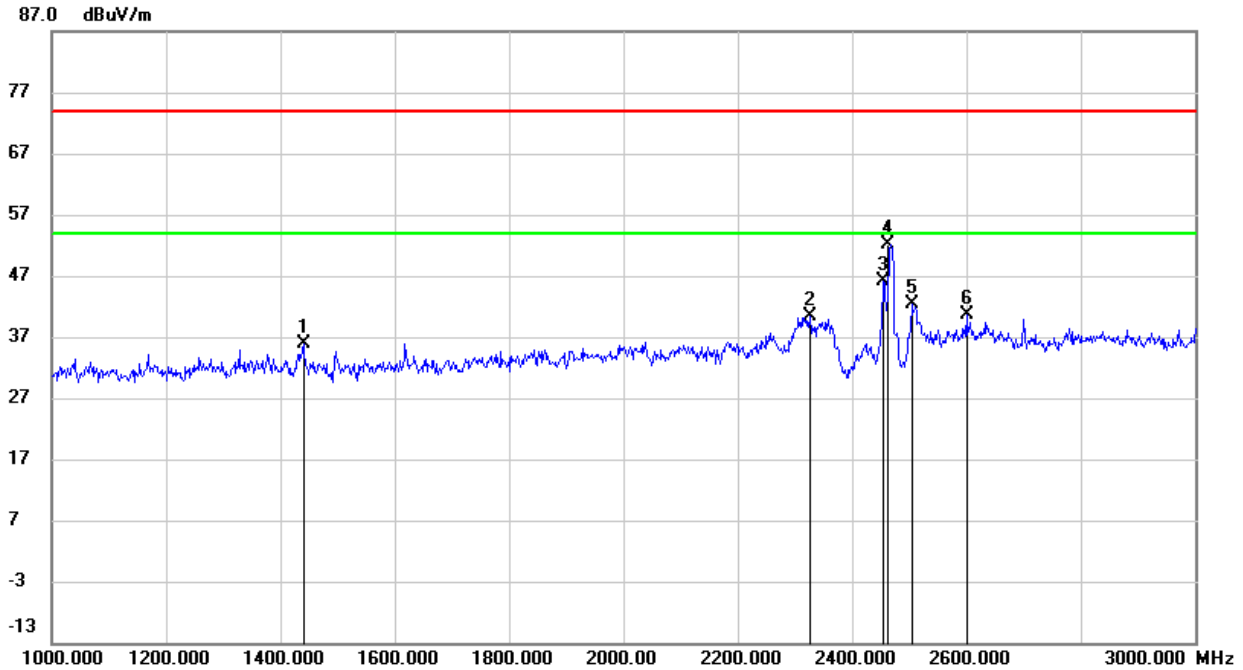

No.	Frequency (MHz)	Reading (dBuV)	Correct (dB/m)	Result (dBuV/m)	Limit (dBuV/m)	Margin (dB)	Remark
1	1440.000	48.10	-12.32	35.78	74.00	-38.22	peak
2	2326.000	48.51	-8.10	40.41	74.00	-33.59	peak
3	2454.000	53.59	-7.48	46.11	74.00	-27.89	peak
4	2462.000	59.44	-7.43	52.01	/	/	fundamental
5	2504.000	49.48	-7.19	42.29	74.00	-31.71	peak
6	2600.000	48.26	-7.70	40.56	74.00	-33.44	peak

- Note: 1. Measurement = Reading Level + Correct Factor.
 2. If Peak Result complies with AV limit, AV Result is deemed to comply with AV limit.
 3. Peak: Peak detector.
 4. Filter losses were only considered in the spurious frequency bands and the authorized band was not corrected for Band Reject Filter losses.
 5. Proper operation of the transmitter prior to adding the filter to the measurement chain.



8.4. SPURIOUS EMISSIONS (18~26GHz)

8.4.1. 802.11g MODE

SPURIOUS EMISSIONS (CHANNEL 11, WORST-CASE CONFIGURATION, HORIZONTAL)

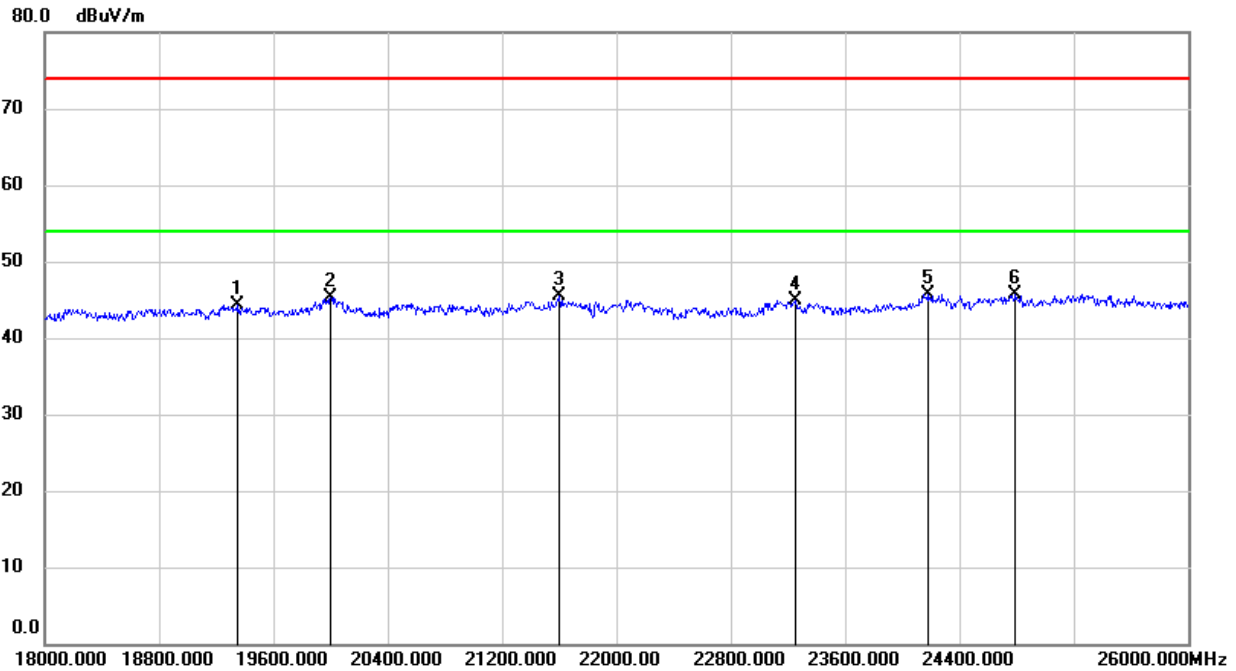

No.	Frequency (MHz)	Reading (dBuV)	Correct (dB/m)	Result (dBuV/m)	Limit (dBuV/m)	Margin (dB)	Remark
1	19352.000	49.86	-5.57	44.29	74.00	-29.71	peak
2	20000.000	50.81	-5.45	45.36	74.00	-28.64	peak
3	21600.000	50.02	-4.54	45.48	74.00	-28.52	peak
4	23256.000	48.22	-3.35	44.87	74.00	-29.13	peak
5	24184.000	48.43	-2.80	45.63	74.00	-28.37	peak
6	24792.000	47.98	-2.28	45.70	74.00	-28.30	peak

- Note: 1. Measurement = Reading Level + Correct Factor.
 2. If Peak Result complies with AV limit, AV Result is deemed to comply with AV limit.
 3. Peak: Peak detector.
 4. The preamplifier only effect to the above 18GHz signal and no filter added to the measurement chain.



SPURIOUS EMISSIONS (CHANNEL 11, WORST-CASE CONFIGURATION, VERTICAL)

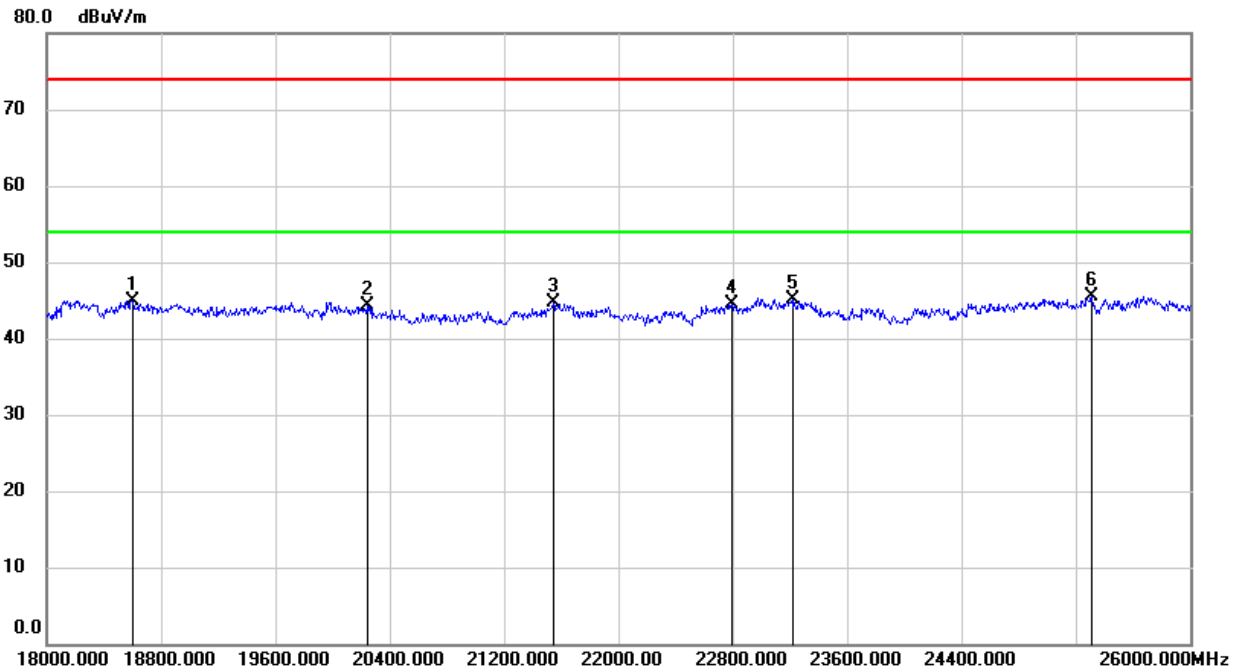

No.	Frequency (MHz)	Reading (dBuV)	Correct (dB/m)	Result (dBuV/m)	Limit (dBuV/m)	Margin (dB)	Remark
1	18600.000	50.20	-5.32	44.88	74.00	-29.12	peak
2	20240.000	49.82	-5.61	44.21	74.00	-29.79	peak
3	21544.000	49.26	-4.63	44.63	74.00	-29.37	peak
4	22792.000	48.11	-3.65	44.46	74.00	-29.54	peak
5	23216.000	48.51	-3.38	45.13	74.00	-28.87	peak
6	25312.000	47.20	-1.70	45.50	74.00	-28.50	peak

- Note: 1. Measurement = Reading Level + Correct Factor.
 2. If Peak Result complies with AV limit, AV Result is deemed to comply with AV limit.
 3. Peak: Peak detector.
 4. The preamplifier only effect to the above 18GHz signal and no filter added to the measurement chain.

Note: All the test modes have been tested, only the worst data record in the report.



8.5. SPURIOUS EMISSIONS (0.03 ~ 1 GHz)

8.5.1. 802.11g MODE

SPURIOUS EMISSIONS (CHANNEL 11, WORST-CASE CONFIGURATION, HORIZONTAL)

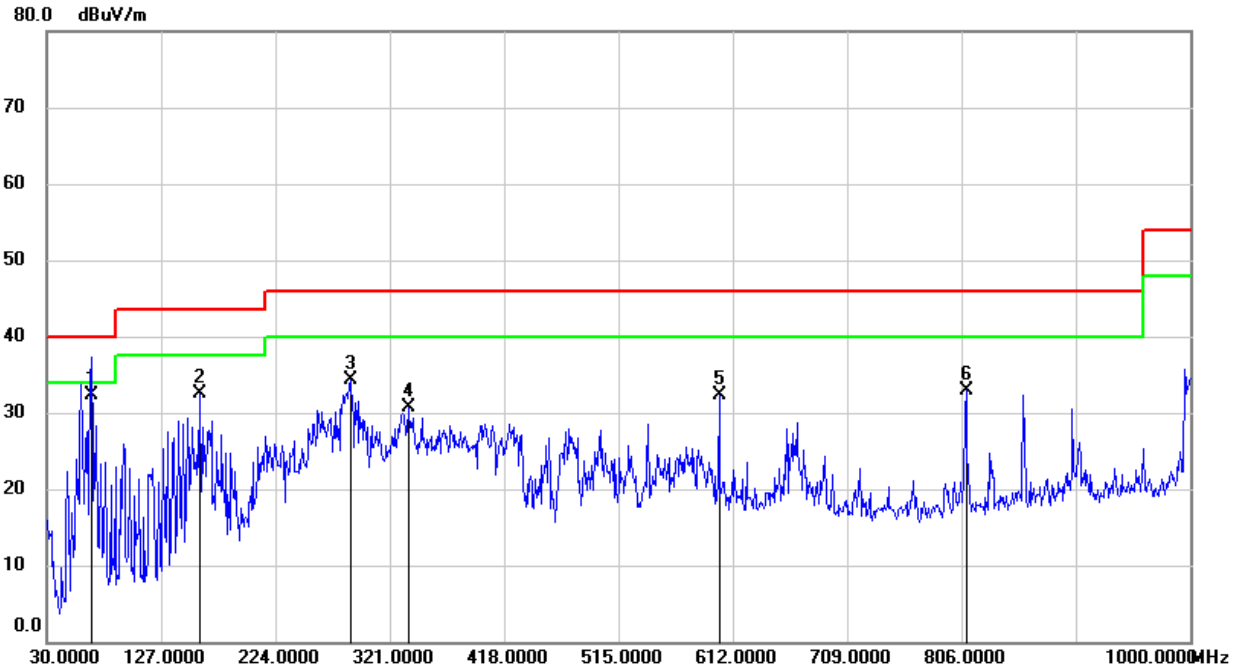

No.	Frequency (MHz)	Reading (dBuV)	Correct (dB/m)	Result (dBuV/m)	Limit (dBuV/m)	Margin (dB)	Remark
1	67.8300	52.86	-20.61	32.25	40.00	-7.75	QP
2	159.9800	50.59	-18.01	32.58	43.50	-10.92	QP
3	288.0200	50.72	-16.51	34.21	46.00	-11.79	QP
4	336.5200	45.39	-14.78	30.61	46.00	-15.39	QP
5	600.3600	42.30	-9.91	32.39	46.00	-13.61	QP
6	809.8800	40.53	-7.66	32.87	46.00	-13.13	QP

Note: 1. Result Level = Read Level + Correct Factor.
2. Test setup: RBW: 120 kHz, VBW: 300 kHz, Sweep time: auto.



SPURIOUS EMISSIONS (CHANNEL 11, WORST-CASE CONFIGURATION, VERTICAL)

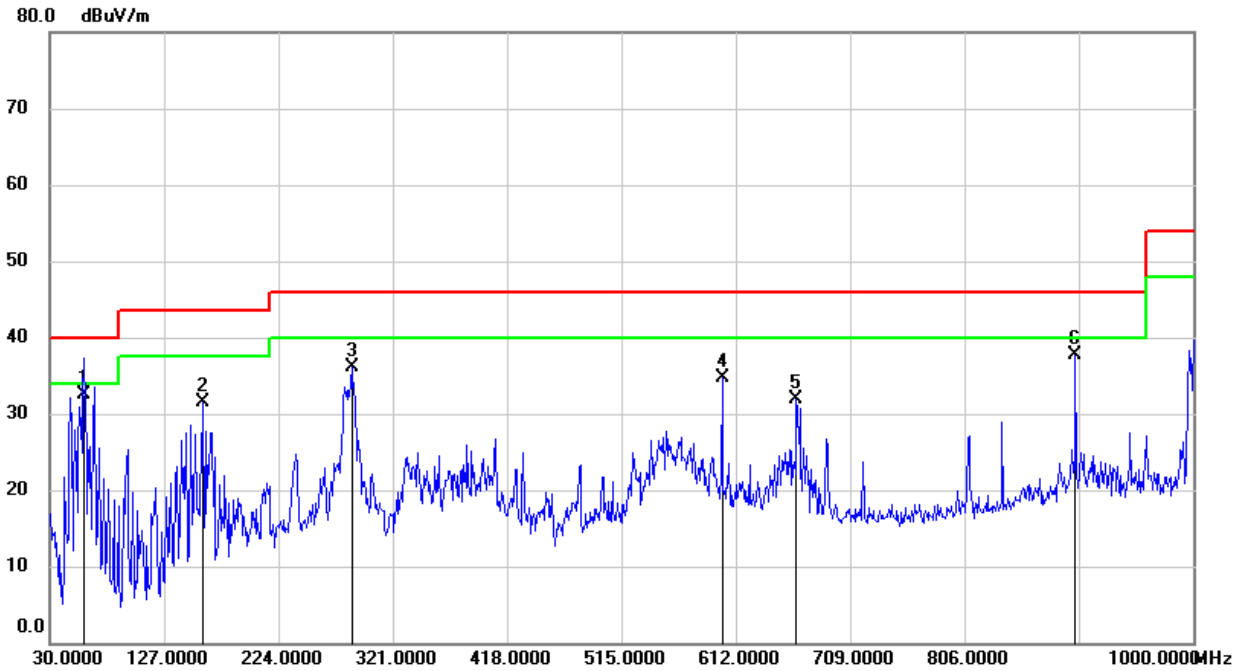

No.	Frequency (MHz)	Reading (dBuV)	Correct (dB/m)	Result (dBuV/m)	Limit (dBuV/m)	Margin (dB)	Remark
1	59.1000	53.22	-20.63	32.59	40.00	-7.41	QP
2	159.9800	49.51	-18.01	31.50	43.50	-12.00	QP
3	286.0799	52.66	-16.64	36.02	46.00	-9.98	QP
4	600.3600	44.53	-9.91	34.62	46.00	-11.38	QP
5	663.4099	41.04	-9.18	31.86	46.00	-14.14	QP
6	900.0900	43.41	-5.65	37.76	46.00	-8.24	QP

Note: 1. Result Level = Read Level + Correct Factor.
2. Test setup: RBW: 120 kHz, VBW: 300 kHz, Sweep time: auto.

Note: All the test modes have been tested, only the worst data record in the report.



8.6. SPURIOUS EMISSIONS BELOW 30M

8.6.1. 802.11g MODE

SPURIOUS EMISSIONS (CHANNEL 11, LOOP ANTENNA FACE ON TO THE EUT, WORST-CASE CONFIGURATION)

9kHz~ 150kHz

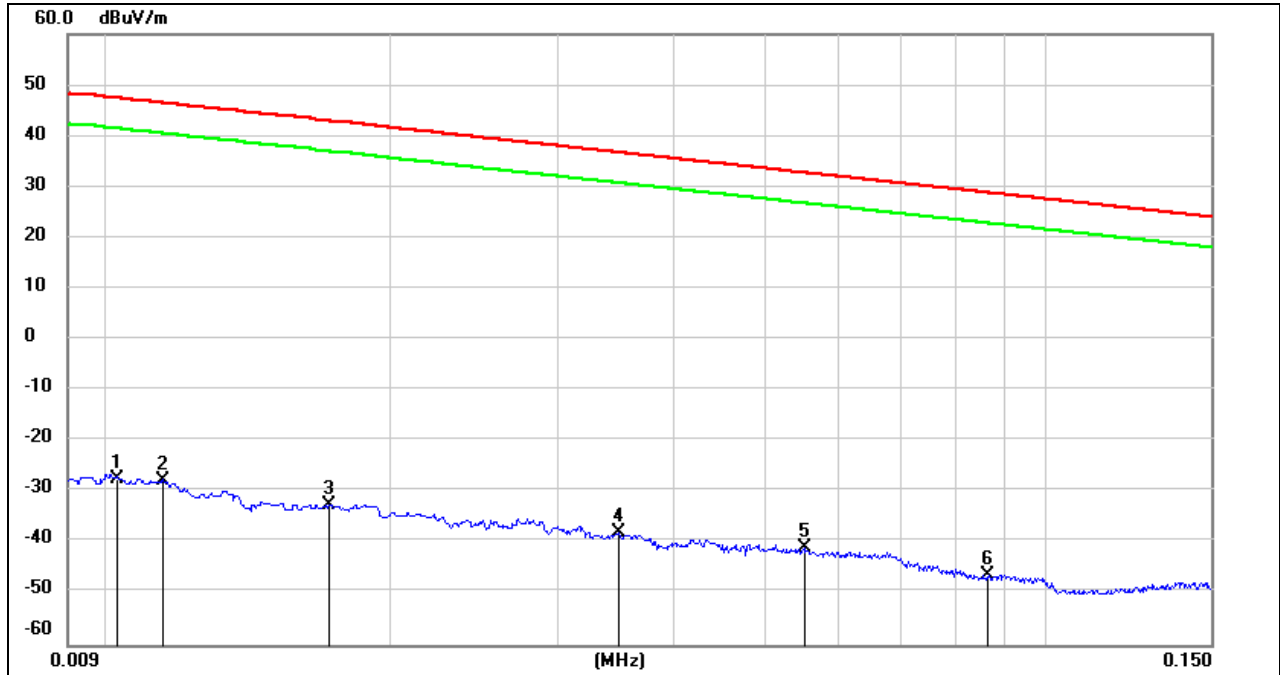

No.	Frequency (MHz)	Reading (dBuV)	Correct (dB/m)	FCC Result (dBuV/m)	FCC Limit (dBuV/m)	ISED Result (dBuA/m)	ISED Limit (dBuA/m)	Margin (dB)	Remark
1	0.0102	74.05	-101.40	-27.35	47.43	-78.85	-4.07	-74.78	peak
2	0.0114	73.50	-101.40	-27.90	46.46	-79.40	-5.04	-74.36	peak
3	0.0171	68.88	-101.36	-32.48	42.94	-83.98	-8.56	-75.42	peak
4	0.0349	63.53	-101.41	-37.88	36.75	-89.38	-14.75	-74.63	peak
5	0.0551	60.45	-101.50	-41.05	32.78	-92.55	-18.72	-73.83	peak
6	0.0868	55.39	-101.69	-46.30	28.83	-97.80	-22.67	-75.13	peak

Note: 1. Measurement = Reading Level + Correct Factor (dBuA/m= dBuV/m- 20Log10[120π] = dBuV/m- 51.5).

2. If Peak Result complies with AV and QP limit, AV and QP Result are deemed to comply with AV limit.

3. All 3 polarizations(Horizontal, Face-on and Face-off) of the loop antenna had been tested, but only the worst data recorded in the report.



150kHz ~ 490kHz

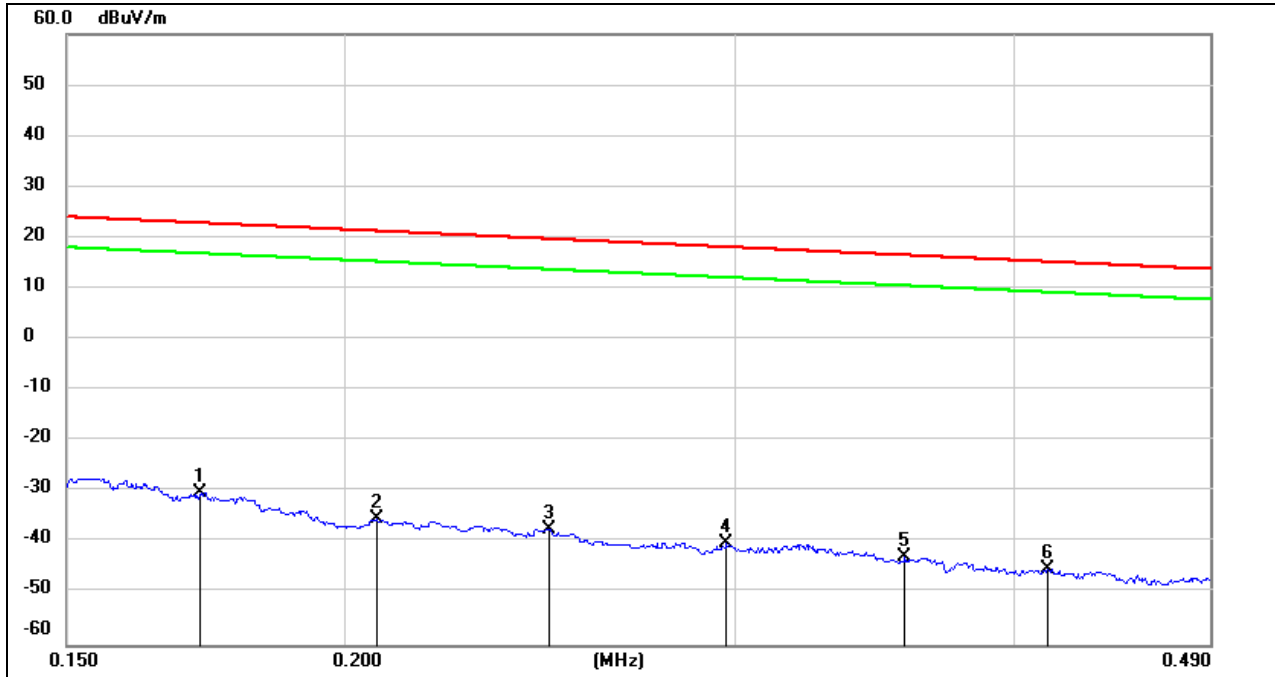

No.	Frequency (MHz)	Reading (dBuV)	Correct (dB/m)	FCC Result (dBuV/m)	FCC Limit (dBuV/m)	ISED Result (dBuA/m)	ISED Limit (dBuA/m)	Margin (dB)	Remark
1	0.1723	71.50	-101.67	-30.17	22.88	-81.67	-28.62	-53.05	peak
2	0.2068	66.45	-101.73	-35.28	21.29	-86.78	-30.21	-56.57	peak
3	0.2472	64.45	-101.80	-37.35	19.74	-88.85	-31.76	-57.09	peak
4	0.2972	61.66	-101.85	-40.19	18.14	-91.69	-33.36	-58.33	peak
5	0.3573	59.08	-101.91	-42.83	16.54	-94.33	-34.96	-59.37	peak
6	0.4142	56.73	-101.98	-45.25	15.26	-96.75	-36.24	-60.51	peak

Note: 1. Measurement = Reading Level + Correct Factor (dBuA/m= dBuV/m- 20Log10[120π] = dBuV/m- 51.5).

2. If Peak Result complies with AV and QP limit, AV and QP Result are deemed to comply with AV limit.

3. All 3 polarizations(Horizontal, Face-on and Face-off) of the loop antenna had been tested, but only the worst data recorded in the report.



490kHz ~ 30MHz

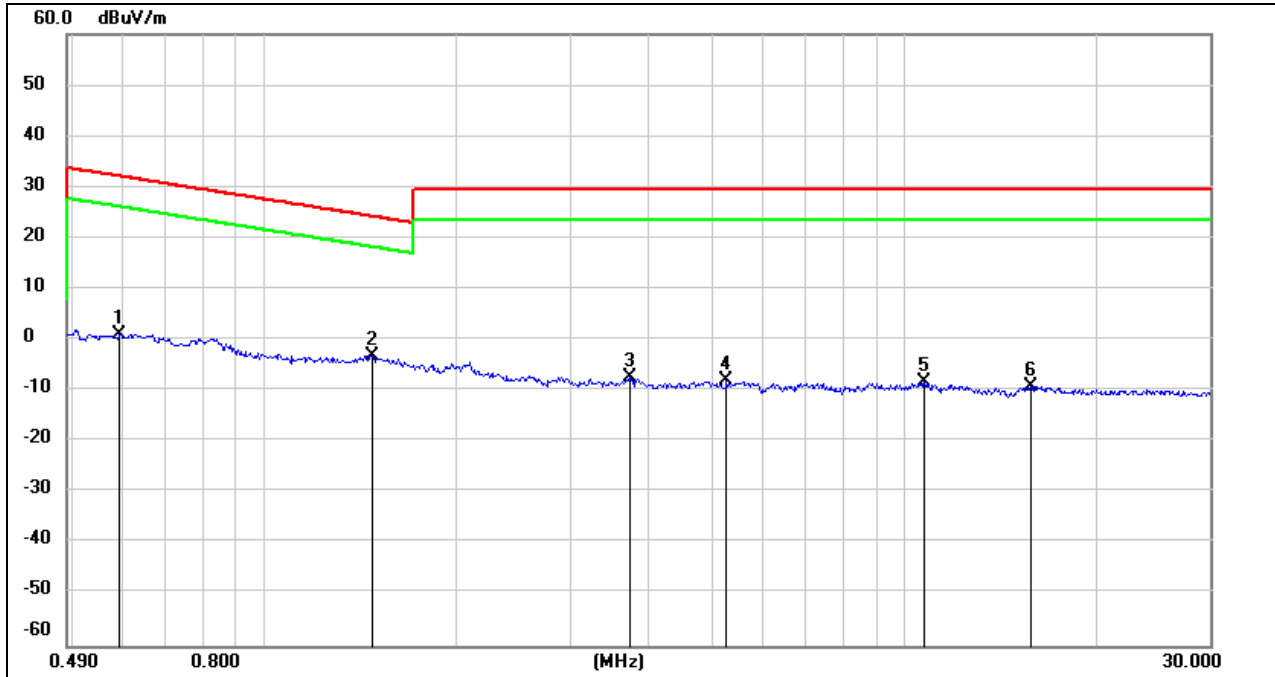

No.	Frequency (MHz)	Reading (dBuV)	Correct (dB/m)	FCC Result (dBuV/m)	FCC Limit (dBuV/m)	ISED Result (dBuA/m)	ISED Limit (dBuA/m)	Margin (dB)	Remark
1	0.5917	63.24	-62.08	1.16	32.16	-50.34	-19.34	-31.00	peak
2	1.4700	58.89	-62.05	-3.16	24.26	-54.66	-27.24	-27.42	peak
3	3.7100	54.20	-61.41	-7.21	29.54	-58.71	-21.96	-36.75	peak
4	5.2705	53.54	-61.45	-7.91	29.54	-59.41	-21.96	-37.45	peak
5	10.7299	52.48	-60.83	-8.35	29.54	-59.85	-21.96	-37.89	peak
6	15.7759	51.75	-60.99	-9.24	29.54	-60.74	-21.96	-38.78	peak

Note: 1. Measurement = Reading Level + Correct Factor (dBuA/m= dBuV/m- 20Log10[120π] = dBuV/m- 51.5).

2. If Peak Result complies with AV and QP limit, AV and QP Result are deemed to comply with AV limit.

3. All 3 polarizations(Horizontal, Face-on and Face-off) of the loop antenna had been tested, but only the worst data recorded in the report.

Note: All the test modes have been tested, only the worst data record in the report.

9. AC POWER LINE CONDUCTED EMISSIONS

LIMITS

Please refer to CFR 47 FCC §15.207 (a) and ISED RSS-Gen Clause 8.8

FREQUENCY (MHz)	Quasi-peak	Average
0.15 -0.5	66 - 56 *	56 - 46 *
0.50 -5.0	56.00	46.00
5.0 -30.0	60.00	50.00

TEST SETUP AND PROCEDURE

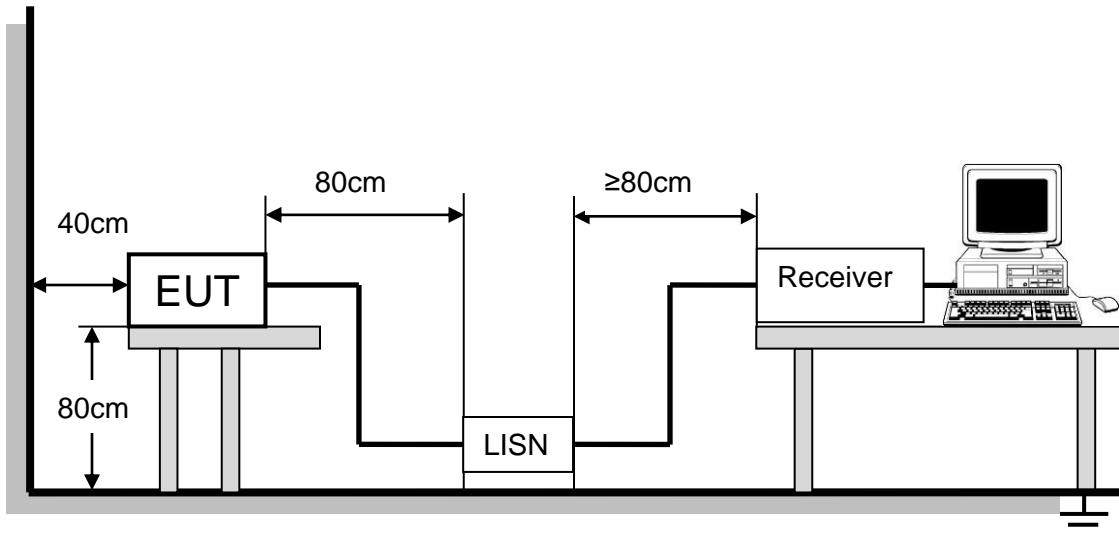

The EUT is put on a table of non-conducting material that is 80cm high. The vertical conducting wall of shielding is located 40cm to the rear of the EUT. The power line of the EUT is connected to the AC mains through a Artificial Mains Network (A.M.N.). A EMI Measurement Receiver (R&S Test Receiver ESR3) is used to test the emissions from both sides of AC line. According to the requirements in Section 6.2 of ANSI C63.10-2013. Conducted emissions from the EUT measured in the frequency range between 0.15 MHz and 30MHz using CISPR Quasi-Peak and average detector mode. The bandwidth of EMI test receiver is set at 9kHz.

The arrangement of the equipment is installed to meet the standards and operating in a manner, which tends to maximize its emission characteristics in a normal application.

TEST ENVIRONMENT

Temperature	24.3°C	Relative Humidity	67.2%
Atmosphere Pressure	101kPa	Test Voltage	AC 120V, 60Hz



TEST RESULTS

9.1. 802.11b MODE

LINE N RESULTS (CHANNEL 11, WORST-CASE CONFIGURATION)

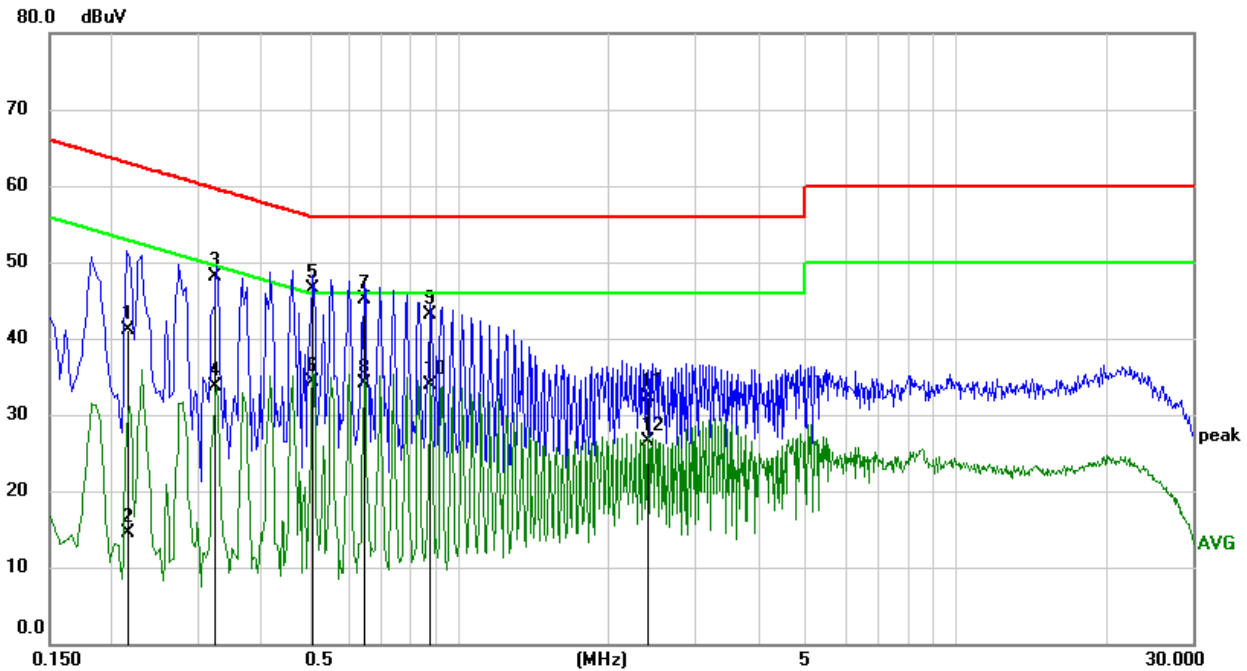

No.	Frequency (MHz)	Reading (dBuV)	Correct (dB)	Result (dBuV)	Limit (dBuV)	Margin (dB)	Remark
1	0.2168	31.47	9.60	41.07	62.94	-21.87	QP
2	0.2168	4.85	9.60	14.45	52.94	-38.49	AVG
3	0.3229	38.53	9.60	48.13	59.63	-11.50	QP
4	0.3229	24.17	9.60	33.77	49.63	-15.86	AVG
5	0.5088	37.00	9.60	46.60	56.00	-9.40	QP
6	0.5088	24.76	9.60	34.36	46.00	-11.64	AVG
7	0.6459	35.45	9.60	45.05	56.00	-10.95	QP
8	0.6459	24.59	9.60	34.19	46.00	-11.81	AVG
9	0.8787	33.47	9.60	43.07	56.00	-12.93	QP
10	0.8787	24.27	9.60	33.87	46.00	-12.13	AVG
11	2.4035	22.74	9.63	32.37	56.00	-23.63	QP
12	2.4035	16.91	9.63	26.54	46.00	-19.46	AVG

- Note: 1. Result = Reading +Correct Factor.
 2. If QP Result complies with AV limit, AV Result is deemed to comply with AV limit.
 3. Test setup: RBW: 200 Hz (9 kHz-150 kHz), 9 kHz (150 kHz-30 MHz).
 4. Step size: 80Hz (0.009MHz-0.15MHz), 4 kHz (0.15MHz-30MHz), Scan time: auto.



LINE L RESULTS (CHANNEL 11, WORST-CASE CONFIGURATION)

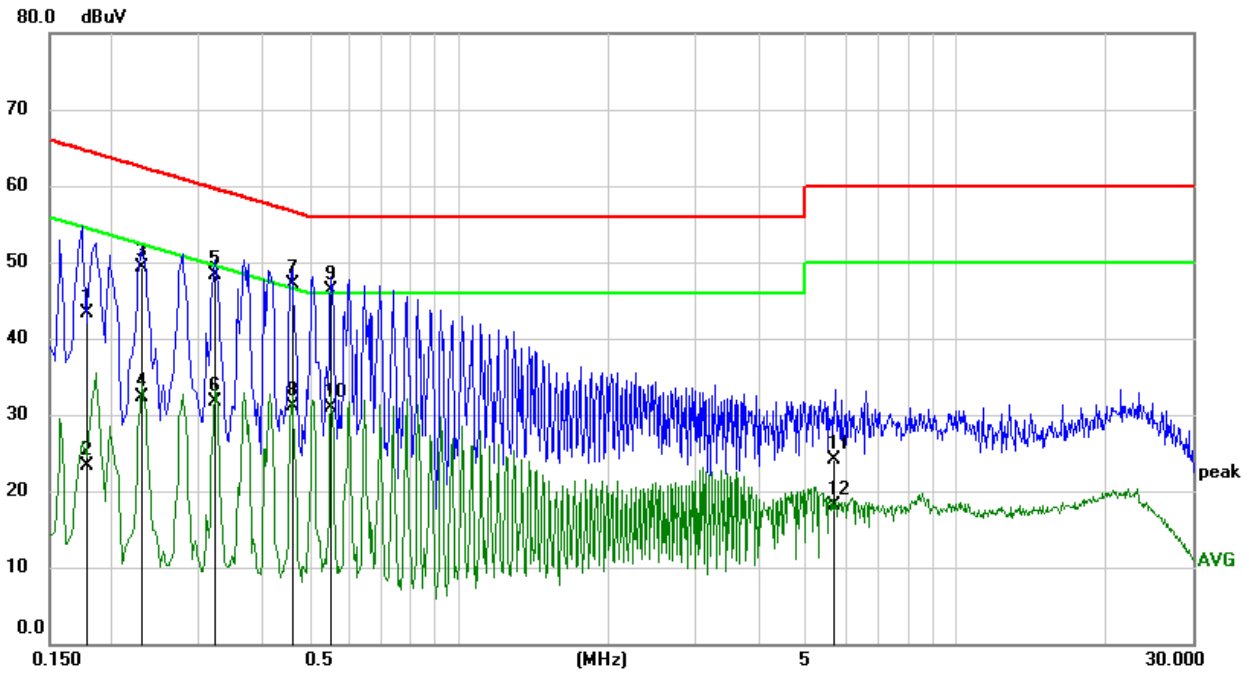

No.	Frequency (MHz)	Reading (dBuV)	Correct (dB)	Result (dBuV)	Limit (dBuV)	Margin (dB)	Remark
1	0.1784	33.74	9.61	43.35	64.56	-21.21	QP
2	0.1784	13.66	9.61	23.27	54.56	-31.29	AVG
3	0.2315	39.78	9.60	49.38	62.40	-13.02	QP
4	0.2315	22.67	9.60	32.27	52.40	-20.13	AVG
5	0.3227	38.66	9.60	48.26	59.64	-11.38	QP
6	0.3227	22.09	9.60	31.69	49.64	-17.95	AVG
7	0.4620	37.45	9.60	47.05	56.66	-9.61	QP
8	0.4620	21.60	9.60	31.20	46.66	-15.46	AVG
9	0.5546	36.66	9.60	46.26	56.00	-9.74	QP
10	0.5546	21.38	9.60	30.98	46.00	-15.02	AVG
11	5.6822	14.45	9.69	24.14	60.00	-35.86	QP
12	5.6822	8.34	9.69	18.03	50.00	-31.97	AVG

- Note: 1. Result = Reading +Correct Factor.
 2. If QP Result complies with AV limit, AV Result is deemed to comply with AV limit.
 3. Test setup: RBW: 200 Hz (9 kHz-150 kHz), 9 kHz (150 kHz-30 MHz).
 4. Step size: 80Hz (0.009MHz-0.15MHz), 4 kHz (0.15MHz-30MHz), Scan time: auto.

Note: All the test modes have been tested, only the worst data record in the report.