



FCC Test Report

Equipment : AC1200 Wireless MU-MIMO Gigabit Indoor/Outdoor Access Point

Brand Name : tp-link

Model No. : EAP225-Outdoor

FCC ID : TE7EAP225OD

Standard : 47 CFR FCC Part 15.247

Operating Band : 2400 MHz – 2483.5 MHz

Function : Point-to-multipoint; Point-to-point

Applicant : TP-Link Technologies Co., Ltd.
Building 24 (floors 1,3,4,5) and 28 (floors1-4), Central Science and Technology Park,Nanshan Shenzhen, 518057 China

Manufacturer : TP-Link Technologies Co., Ltd.
Building 24 (floors 1,3,4,5) and 28 (floors1-4), Central Science and Technology Park,Nanshan Shenzhen, 518057 China

The product sample received on Sep. 08, 2017 and completely tested on Oct. 18, 2017. We, SPORTON, would like to declare that the tested sample has been evaluated in accordance with the procedures given in ANSI C63.10-2013 and shown compliance with the applicable technical standards.

The test results in this report apply exclusively to the tested model / sample. Without written approval of SPORTON INTERNATIONAL INC., the test report shall not be reproduced except in full.

Cliff Chang
SPORTON INTERNATIONAL INC.





Table of Contents

- 1 GENERAL DESCRIPTION5**
- 1.1 Information.....5
- 1.2 Testing Applied Standards7
- 1.3 Testing Location Information7
- 1.4 Measurement Uncertainty7
- 2 TEST CONFIGURATION OF EUT8**
- 2.1 Test Channel Mode8
- 2.2 The Worst Case Measurement Configuration.....9
- 2.3 EUT Operation during Test10
- 2.4 Accessories10
- 2.5 Support Equipment.....10
- 2.6 Test Setup Diagram11
- 3 TRANSMITTER TEST RESULT14**
- 3.1 AC Power-line Conducted Emissions14
- 3.2 DTS Bandwidth16
- 3.3 Maximum Conducted Output Power17
- 3.4 Power Spectral Density19
- 3.5 Emissions in Non-restricted Frequency Bands21
- 3.6 Emissions in Restricted Frequency Bands.....22
- 4 TEST EQUIPMENT AND CALIBRATION DATA26**

APPENDIX A. TEST RESULTS OF AC POWER-LINE CONDUCTED EMISSIONS

APPENDIX B. TEST RESULTS OF DTS BANDWIDTH

APPENDIX C. TEST RESULTS OF MAXIMUM CONDUCTED OUTPUT POWER

APPENDIX D. TEST RESULTS OF POWER SPECTRAL DENSITY

APPENDIX E. TEST RESULTS OF EMISSIONS IN NON-RESTRICTED FREQUENCY BANDS

APPENDIX F. TEST RESULTS OF EMISSIONS IN RESTRICTED FREQUENCY BANDS

APPENDIX G. TEST RESULTS OF RADIATED EMISSION CO-LOCATION

APPENDIX H. TEST PHOTOS

PHOTOGRAPHS OF EUT V01



Summary of Test Result

| Conformance Test Specifications | | | | |
|---------------------------------|------------------|---|-----------------------------------|----------|
| Report Clause | Ref. Std. Clause | Description | Limit | Result |
| 1.1.2 | 15.203 | Antenna Requirement | FCC 15.203 | Complied |
| 3.1 | 15.207 | AC Power-line Conducted Emissions | FCC 15.207 | Complied |
| 3.2 | 15.247(a) | DTS Bandwidth | ≥500kHz | Complied |
| 3.3 | 15.247(b) | Maximum Conducted Output Power | Power [dBm]:30 | Complied |
| 3.4 | 15.247(e) | Power Spectral Density | PSD [dBm/3kHz]:8 | Complied |
| 3.5 | 15.247(d) | Emissions in Non-restricted Frequency Bands | Non-Restricted Bands: > 30 dBc | Complied |
| 3.6 | 15.247(d) | Emissions in Restricted Frequency Bands | Restricted Bands: FCC 15.209 | Complied |



Revision History

| Report No. | Version | Description | Issued Date |
|------------|---------|-------------------------|---------------|
| FR790815AA | Rev. 01 | Initial issue of report | Nov. 20, 2017 |
| | | | |
| | | | |
| | | | |
| | | | |
| | | | |
| | | | |
| | | | |
| | | | |
| | | | |
| | | | |
| | | | |
| | | | |
| | | | |
| | | | |
| | | | |
| | | | |
| | | | |
| | | | |
| | | | |
| | | | |
| | | | |
| | | | |
| | | | |
| | | | |
| | | | |
| | | | |
| | | | |
| | | | |
| | | | |
| | | | |
| | | | |
| | | | |
| | | | |
| | | | |
| | | | |
| | | | |

1 General Description

1.1 Information

1.1.1 RF General Information

| Frequency Range (MHz) | IEEE Std. 802.11 | Ch. Frequency (MHz) | Channel Number |
|-----------------------|------------------|---------------------|----------------|
| 2400-2483.5 | b, g, n (HT20) | 2412-2462 | 1-11 [11] |
| 2400-2483.5 | n (HT40) | 2422-2452 | 3-9 [7] |

| Band | Mode | BWch (MHz) | Nant |
|---------------|--------------|------------|------|
| 2.4-2.4835GHz | 802.11b | 20 | 2TX |
| 2.4-2.4835GHz | 802.11g | 20 | 2TX |
| 2.4-2.4835GHz | 802.11n HT20 | 20 | 2TX |
| 2.4-2.4835GHz | 802.11n HT40 | 40 | 2TX |

Note:

- 2.4G is the 2.4GHz Band (2.4-2.4835GHz).
- 11b mode uses a combination of DSSS-DBPSK, DQPSK, CCK modulation.
- 11g, HT20 and HT40 use a combination of OFDM-BPSK, QPSK, 16QAM, 64QAM modulation.
- BWch is the nominal channel bandwidth.
- Nss-Min is the minimum number of spatial streams.
- Nant is the number of outputs. e.g., 2(2,3) means have 2 outputs for port 2 and port 3. 2 means have 2 outputs for port 1 and port 2.

1.1.2 Antenna Information

| Ant. | Brand | P/N | Antenna Type | Connector | Gain (dBi) | | |
|------|---------|------------|----------------|-----------|------------|-------------|-------------|
| | | | | | 2.4GHz | 5GHz Band 1 | 5GHz Band 4 |
| 1 | tp-link | 3101501275 | Dipole Antenna | RP-SMA-F | 3.36 | 5.19 | 4.56 |
| 2 | tp-link | 3101501275 | Dipole Antenna | RP-SMA-F | 3.36 | 5.19 | 4.56 |

Note: The EUT has two antennas.

For WLAN 2.4GHz (2TX/2RX):

Ant. 1 (Port 1) and Ant. 2 (Port 2) could transmit/receive simultaneously.

For WLAN 5GHz (2TX/2RX):

Ant. 1 (Port 2) and Ant. 2 (Port 1) could transmit/receive simultaneously.



1.1.3 Mode Test Duty Cycle

| Mode | DC | DCF(dB) | T(s) | VBW(Hz) ≥ 1/T |
|--------------|-------|---------|---------------|---------------|
| 802.11b | 0.996 | 0.017 | n/a (DC≥0.98) | n/a (DC≥0.98) |
| 802.11g | 0.973 | 0.119 | 2.02m | 1k |
| 802.11n HT20 | 0.97 | 0.132 | 1.885m | 1k |
| 802.11n HT40 | 0.948 | 0.232 | 925u | 3k |

1.1.4 EUT Operational Condition

| | | |
|------------------------------|--|--|
| EUT Power Type | From PoE | |
| Beamforming Function | <input checked="" type="checkbox"/> With beamforming | <input type="checkbox"/> Without beamforming |
| | The product has beamforming function for 802.11n/ac in 5GHz. | |
| Test Software Version | QCA | |



1.2 Testing Applied Standards

According to the specifications of the manufacturer, the EUT must comply with the requirements of the following standards:

- ◆ 47 CFR FCC Part 15
- ◆ ANSI C63.10-2013
- ◆ FCC KDB 558074 D01 v04
- ◆ FCC KDB 662911 D01 v02r01
- ◆ FCC KDB 412172 D01 v01r01

1.3 Testing Location Information

| Testing Location | | |
|-------------------------------------|--------|---|
| <input type="checkbox"/> | HWA YA | ADD : No. 52, Hwa Ya 1st Rd., Kwei-Shan Hsiang, Tao Yuan Hsien, Taiwan, R.O.C. TEL : 886-3-327-3456 FAX : 886-3-318-0055 |
| <input checked="" type="checkbox"/> | JHUBEI | ADD : No.8, Lane 724, Bo-ai St., Jhubei City, HsinChu County 302, Taiwan, R.O.C. TEL : 886-3-656-9065 FAX : 886-3-656-9085 |

| Test Condition | Test Site No. | Test Engineer | Test Environment | Test Date |
|----------------|---------------|-------------------------|------------------|---------------------------------|
| RF Conducted | TH01-CB | Eddie Weng & Brian Sun | 22°C / 54% | Sep. 21, 2017~ Oct. 18, 2017 |
| Radiated | 03CH01-CB | Welson Chen & Zero Chen | 22°C / 54% | Sep. 13, 2017~ Oct. 03, 2017 |
| AC Conduction | CO01-CB | Max Lin & Rick Yeh | 26°C / 58% | Sep. 15, 2017 |

Test site Designation No. TW0006 with FCC.
Test site registered number IC 4086D with Industry Canada.

1.4 Measurement Uncertainty

ISO/IEC 17025 requires that an estimate of the measurement uncertainties associated with the emissions test results be included in the report. The measurement uncertainties given below are based on a 95% confidence level (based on a coverage factor (k=2))

| Test Items | Uncertainty | Remark |
|--------------------------------------|------------------------|--------------------------|
| Conducted Emission (150kHz ~ 30MHz) | 3.2 dB | Confidence levels of 95% |
| Radiated Emission (30MHz ~ 1,000MHz) | 3.6 dB | Confidence levels of 95% |
| Radiated Emission (1GHz ~ 18GHz) | 3.7 dB | Confidence levels of 95% |
| Radiated Emission (18GHz ~ 40GHz) | 3.5 dB | Confidence levels of 95% |
| Conducted Emission | 1.7 dB | Confidence levels of 95% |
| Output Power Measurement | 1.33 dB | Confidence levels of 95% |
| Power Density Measurement | 1.27 dB | Confidence levels of 95% |
| Bandwidth Measurement | 9.74 x10 ⁻⁸ | Confidence levels of 95% |



2 Test Configuration of EUT

2.1 Test Channel Mode

| Mode | Power Setting |
|------------------------------|---------------|
| 802.11b_Nss1,(1Mbps)_2TX | - |
| 2412MHz | 19 |
| 2437MHz | 20 |
| 2462MHz | 19.5 |
| 802.11g_Nss1,(6Mbps)_2TX | - |
| 2412MHz | 19 |
| 2437MHz | 27 |
| 2462MHz | 19 |
| 802.11n HT20_Nss1,(MCS0)_2TX | - |
| 2412MHz | 18.5 |
| 2437MHz | 29 |
| 2462MHz | 19 |
| 802.11n HT40_Nss1,(MCS0)_2TX | - |
| 2422MHz | 15.5 |
| 2437MHz | 21 |
| 2452MHz | 17 |

2.2 The Worst Case Measurement Configuration

| The Worst Case Mode for Following Conformance Tests | |
|---|--|
| Tests Item | AC power-line conducted emissions |
| Condition | AC power-line conducted measurement for line and neutral |
| Operating Mode | Normal Link |
| 1 | EUT + PoE |

| The Worst Case Mode for Following Conformance Tests | |
|---|--|
| Tests Item | DTS Bandwidth Maximum Conducted Output Power Power Spectral Density Emissions in Non-restricted Frequency Bands |
| Test Condition | Conducted measurement at transmit chains |

| The Worst Case Mode for Following Conformance Tests | |
|---|---|
| Tests Item | Emissions in Restricted Frequency Bands |
| Test Condition | Radiated measurement If EUT consist of multiple antenna assembly (multiple antenna are used in EUT regardless of spatial multiplexing MIMO configuration), the radiated test should be performed with highest antenna gain of each antenna type. |
| Operating Mode < 1GHz | Normal Link |
| 1 | EUT at Y-axis(antenna in 180°) + PoE |
| Operating Mode > 1GHz | CTX |

| The Worst Case Mode for Following Conformance Tests | |
|--|--|
| Tests Item | Simultaneous Transmission Analysis - Radiated Emission Co-location |
| Test Condition | Radiated measurement |
| Operating Mode | Normal Link |
| 1 | WLAN 2.4GHz +WLAN 5GHz |
| Refer to Appendix G for Radiated Emission Co-location. | |

| The Worst Case Mode for Following Conformance Tests | |
|--|---|
| Tests Item | Simultaneous Transmission Analysis - Co-location RF Exposure Evaluation |
| Operating Mode | |
| 1 | WLAN 2.4GHz+ WLAN 5GHz |
| Refer to Sporton Test Report No.: FA790815 for Co-location RF Exposure Evaluation. | |

Note 1: The EUT can only be used at Y axis position and antenna in 180°.

Note 2: For band-edge emissions, the worst case of the antenna polarization is judged at first, and the worst case is found in vertical.



2.3 EUT Operation during Test

For CTX Mode:

The EUT was programmed to be in continuously transmitting mode.

For Normal Link:

During the test, the EUT operation to normal function.

2.4 Accessories

| Accessories | | | |
|----------------------------------|------------|-------------|---|
| Equipment Name | Brand Name | Model Name | Rating |
| PoE | tp-link | TL-POE2412G | INPUT: 100-240V~50/60Hz 0.4A OUTPUT: 24V, 0.5A |
| Other | | | |
| Power cord*1, Non-shielded, 0.5m | | | |

2.5 Support Equipment

For Test Site No: CO01-CB

| Support Equipment | | | | |
|-------------------|-----------|------------|------------|--------|
| No. | Equipment | Brand Name | Model Name | FCC ID |
| 1 | NB*3 | DELL | E6430 | DoC |

For Test Site No: 03CH01-CB (below 1GHz)

| Support Equipment | | | | |
|-------------------|-----------|------------|------------|--------|
| No. | Equipment | Brand Name | Model Name | FCC ID |
| 1 | NB | DELL | E4300 | DoC |
| 2 | NB*2 | Apple | Mac Book | DoC |

For Test Site No: 03CH01-CB (above 1GHz)

| Support Equipment | | | | |
|-------------------|-----------|------------|------------|--------|
| No. | Equipment | Brand Name | Model Name | FCC ID |
| 1 | NB | DELL | E4300 | DoC |

For Test Site No: TH01-CB

| Support Equipment | | | | |
|-------------------|-----------|------------|------------|--------|
| No. | Equipment | Brand Name | Model Name | FCC ID |
| 1 | NB | DELL | E4300 | DoC |

2.6 Test Setup Diagram

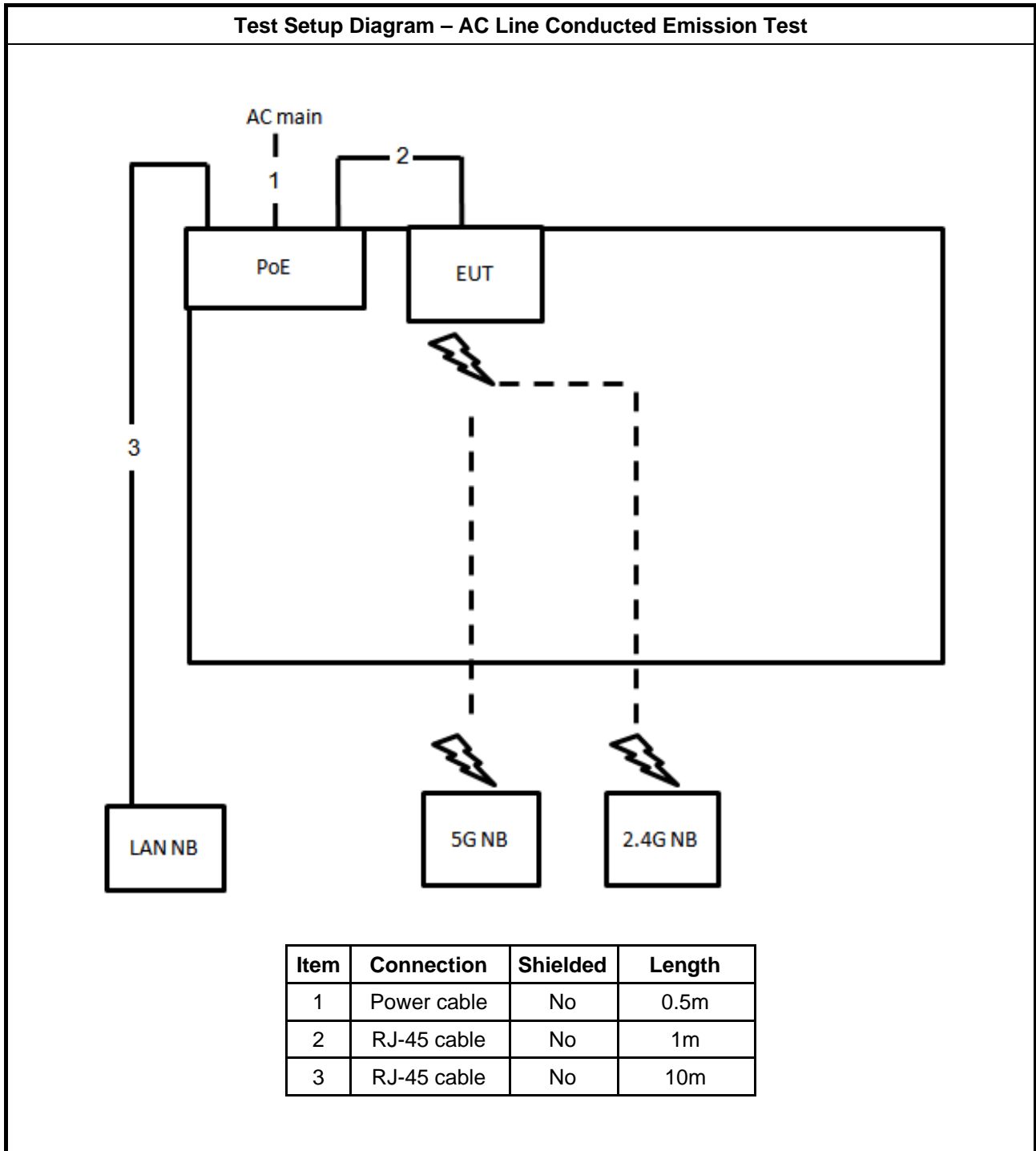

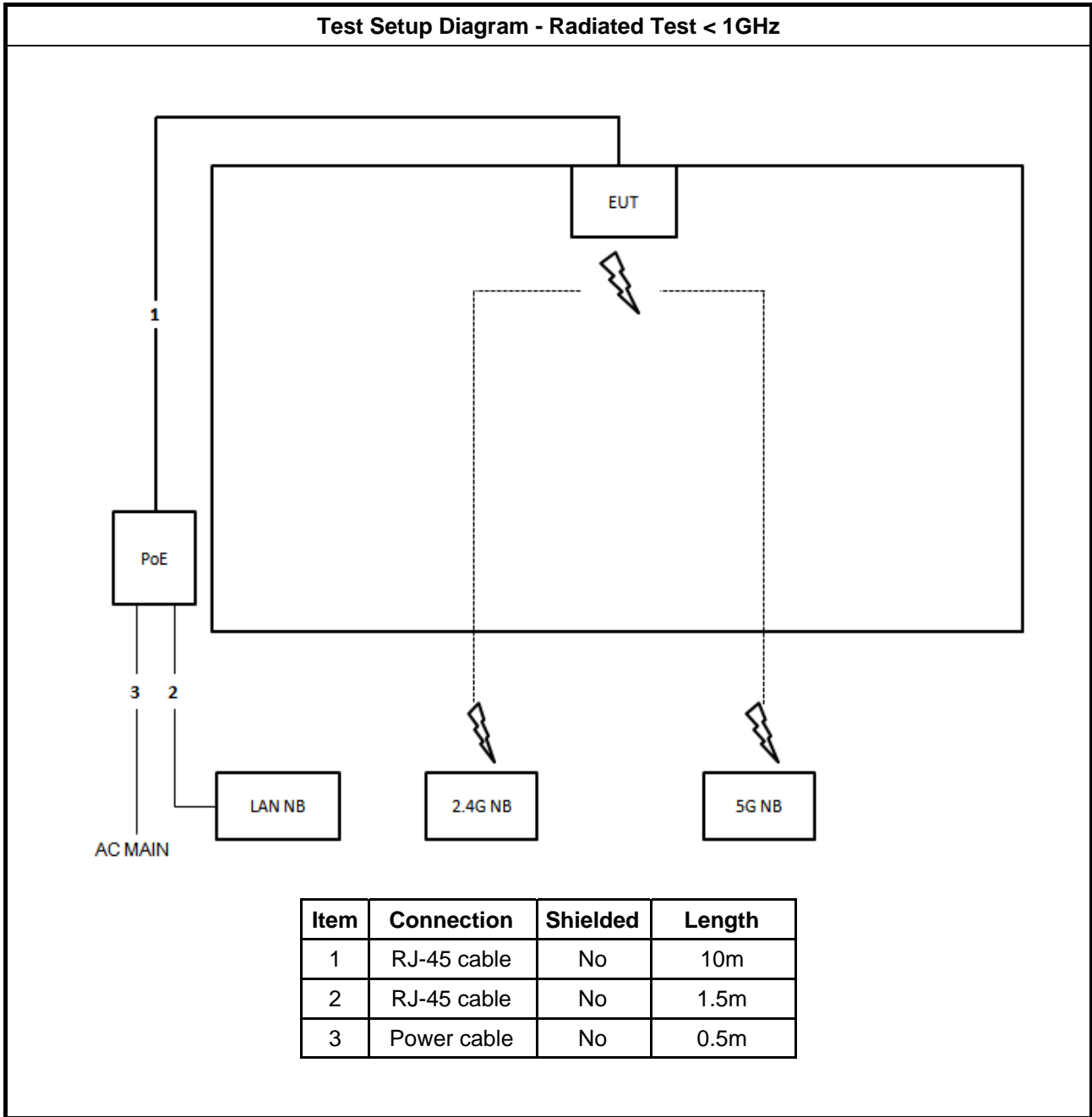

Test Setup Diagram - Radiated Test > 1GHz

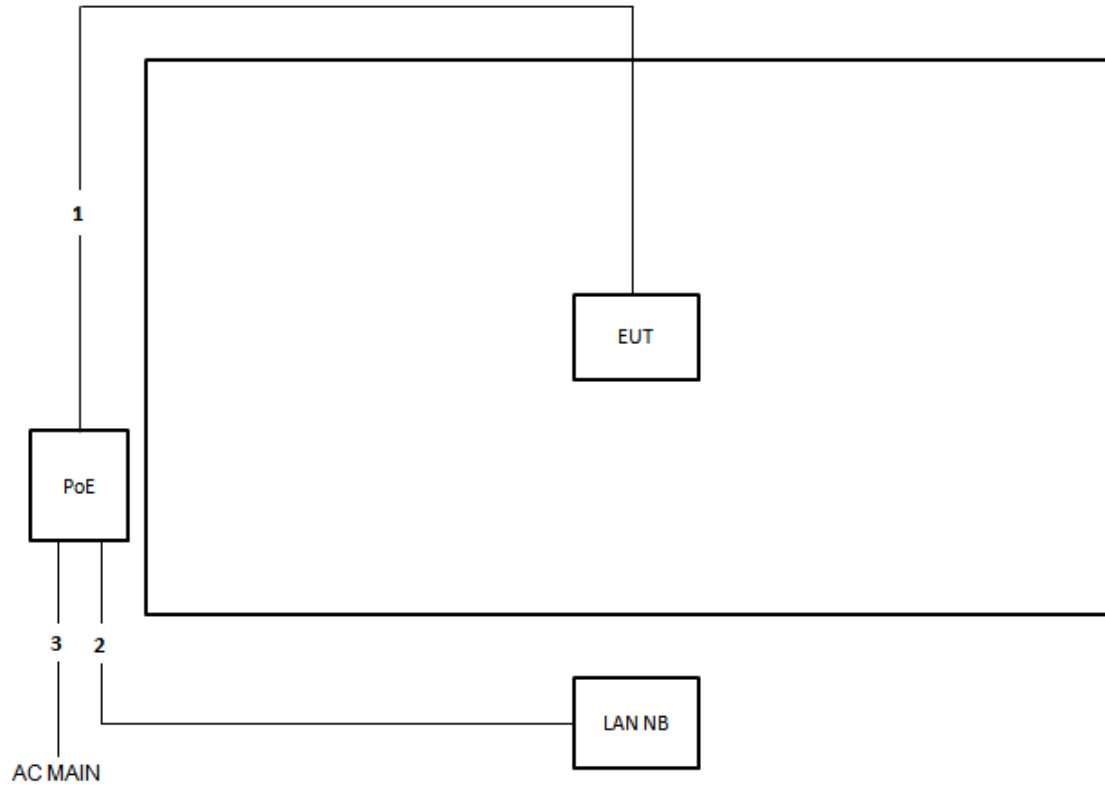

| Item | Connection | Shielded | Length |
|------|-------------|----------|--------|
| 1 | RJ-45 cable | No | 10m |
| 2 | RJ-45 cable | No | 1.5m |
| 3 | Power cable | No | 0.5m |

3 Transmitter Test Result

3.1 AC Power-line Conducted Emissions

3.1.1 AC Power-line Conducted Emissions Limit

| AC Power-line Conducted Emissions Limit | | |
|---|------------|-----------|
| Frequency Emission (MHz) | Quasi-Peak | Average |
| 0.15-0.5 | 66 - 56 * | 56 - 46 * |
| 0.5-5 | 56 | 46 |
| 5-30 | 60 | 50 |

Note 1: * Decreases with the logarithm of the frequency.

3.1.2 Measuring Instruments

Refer a test equipment and calibration data table in this test report.

3.1.3 Test Procedures

| Test Method |
|--|
| <input checked="" type="checkbox"/> Refer as ANSI C63.10-2013, clause 6.2 for AC power-line conducted emissions. |

3.1.4 Test Setup

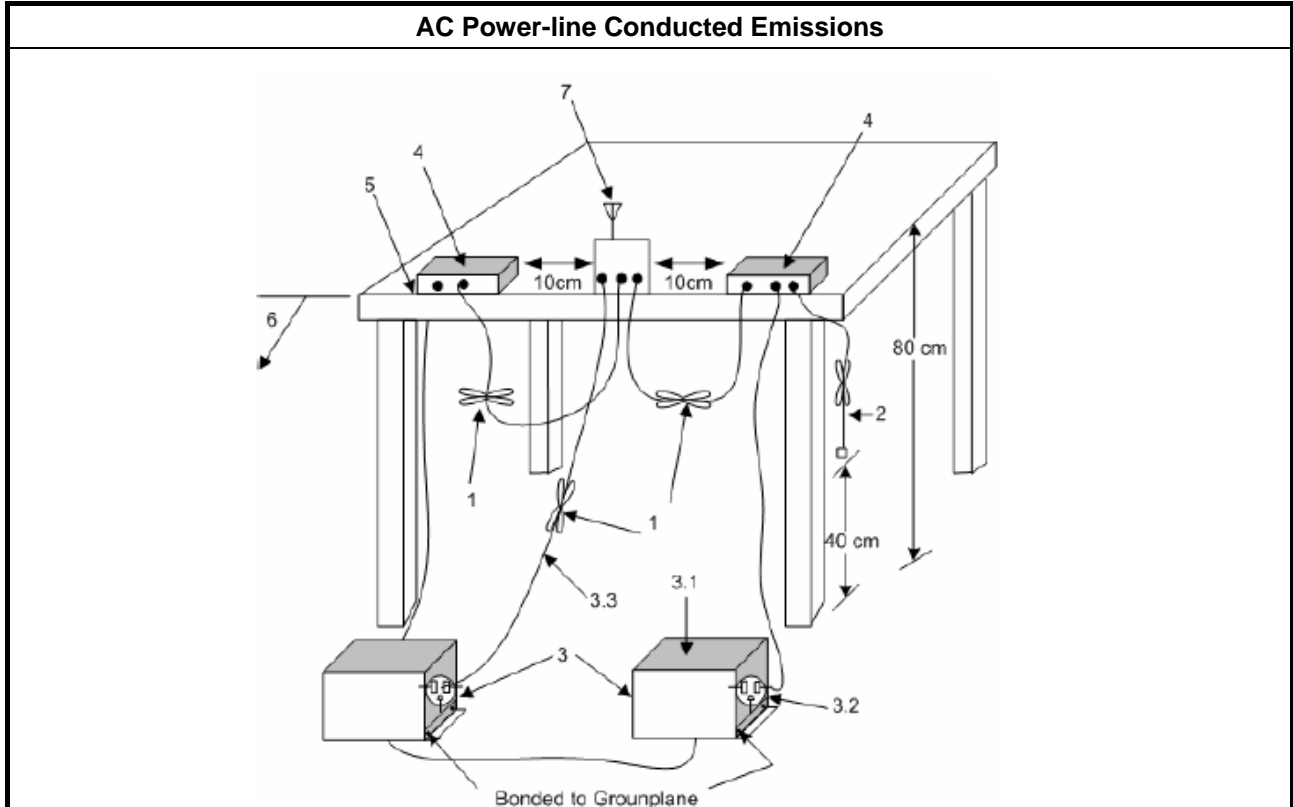



3.1.5 Test Result of AC Power-line Conducted Emissions

Refer as Appendix A

3.2 DTS Bandwidth

3.2.1 6dB Bandwidth Limit

| 6dB Bandwidth Limit |
|---|
| Systems using digital modulation techniques: |
| <ul style="list-style-type: none"> ▪ 6 dB bandwidth \geq 500 kHz. |

3.2.2 Measuring Instruments

Refer a test equipment and calibration data table in this test report.

3.2.3 Test Procedures

| Test Method |
|--|
| <ul style="list-style-type: none"> ▪ For the emission bandwidth shall be measured using one of the options below: |
| <input checked="" type="checkbox"/> Refer as FCC KDB 558074, clause 8.1 Option 1 for 6 dB bandwidth measurement. |
| <input type="checkbox"/> Refer as FCC KDB 558074, clause 8.2 Option 2 for 6 dB bandwidth measurement. |
| <input type="checkbox"/> Refer as ANSI C63.10, clause 6.9.1 for occupied bandwidth testing. |

3.2.4 Test Setup

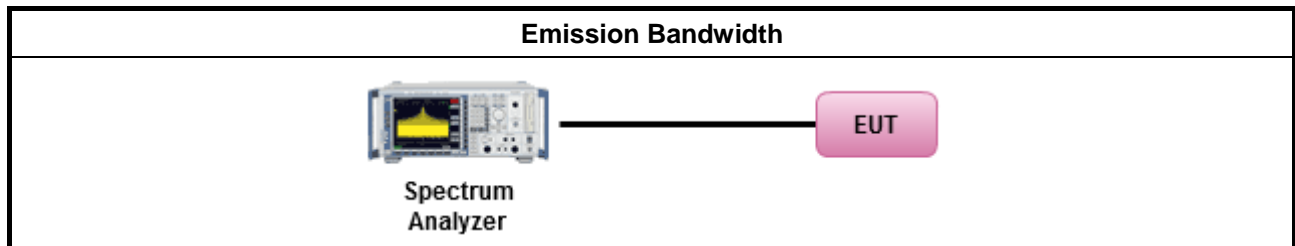

3.2.5 Test Result of Emission Bandwidth

Refer as Appendix B

3.3 Maximum Conducted Output Power

3.3.1 Maximum Conducted Output Power Limit

| Maximum Conducted Output Power Limit | |
|--|---|
| | <ul style="list-style-type: none"> ▪ If $G_{TX} \leq 6$ dBi, then $P_{Out} \leq 30$ dBm (1 W) |
| | <ul style="list-style-type: none"> ▪ Point-to-multipoint systems (P2M): If $G_{TX} > 6$ dBi, then $P_{Out} = 30 - (G_{TX} - 6)$ dBm |
| | <ul style="list-style-type: none"> ▪ Point-to-point systems (P2P): If $G_{TX} > 6$ dBi, then $P_{Out} = 30 - (G_{TX} - 6)/3$ dBm |
| | <ul style="list-style-type: none"> ▪ Smart antenna system (SAS): |
| | <ul style="list-style-type: none"> - Single beam: If $G_{TX} > 6$ dBi, then $P_{Out} = 30 - (G_{TX} - 6)/3$ dBm |
| | <ul style="list-style-type: none"> - Overlap beam: If $G_{TX} > 6$ dBi, then $P_{Out} = 30 - (G_{TX} - 6)/3$ dBm |
| | <ul style="list-style-type: none"> - Aggregate power on all beams: If $G_{TX} > 6$ dBi, then $P_{Out} = 30 - (G_{TX} - 6)/3 + 8$ dB dBm |
| <p>P_{Out} = maximum peak conducted output power or maximum conducted output power in dBm, G_{TX} = the maximum transmitting antenna directional gain in dBi.</p> | |

3.3.2 Measuring Instruments

Refer a test equipment and calibration data table in this test report.

3.3.3 Test Procedures

| Test Method | |
|--|---|
| <ul style="list-style-type: none"> ▪ Maximum Peak Conducted Output Power | |
| <input type="checkbox"/> | Refer as FCC KDB 558074, clause 9.1.1 Option 1 (RBW ≥ EBW method). |
| <input type="checkbox"/> | Refer as FCC KDB 558074, clause 9.1.2 Option 2 (peak power meter for VBW ≥ DTS BW) |
| <ul style="list-style-type: none"> ▪ Maximum Conducted Output Power | |
| [duty cycle ≥ 98% or external video / power trigger] | |
| <input type="checkbox"/> | Refer as FCC KDB 558074, clause 9.2.2.2 Method AVGSA-1 (spectral trace averaging). |
| <input type="checkbox"/> | Refer as FCC KDB 558074, clause 9.2.2.3 Method AVGSA-1 Alt. (slow sweep speed) |
| duty cycle < 98% and average over on/off periods with duty factor | |
| <input type="checkbox"/> | Refer as FCC KDB 558074, clause 9.2.2.4 Method AVGSA-2 (spectral trace averaging). |
| <input type="checkbox"/> | Refer as FCC KDB 558074, clause 9.2.2.5 Method AVGSA-2 Alt. (slow sweep speed) |
| RF power meter and average over on/off periods with duty factor or gated trigger | |
| <input checked="" type="checkbox"/> | Refer as FCC KDB 558074, clause 9.2.3 Method AVGPM-G (using an RF average power meter). |
| <input type="checkbox"/> | Refer as FCC KDB 558074, clause 9.1.2 PKPM1 Peak power meter method. |
| <ul style="list-style-type: none"> ▪ For conducted measurement. | |
| <ul style="list-style-type: none"> ▪ If the EUT supports multiple transmit chains using options given below: Refer as FCC KDB 662911, In-band power measurements. Using the measure-and-sum approach, measured all transmit ports individually. Sum the power (in linear power units e.g., mW) of all ports for each individual sample and save them. | |
| <ul style="list-style-type: none"> ▪ If multiple transmit chains, EIRP calculation could be following as methods: $P_{total} = P_1 + P_2 + \dots + P_n$ (calculated in linear unit [mW] and transfer to log unit [dBm]) $EIRP_{total} = P_{total} + DG$ | |

3.3.4 Test Setup

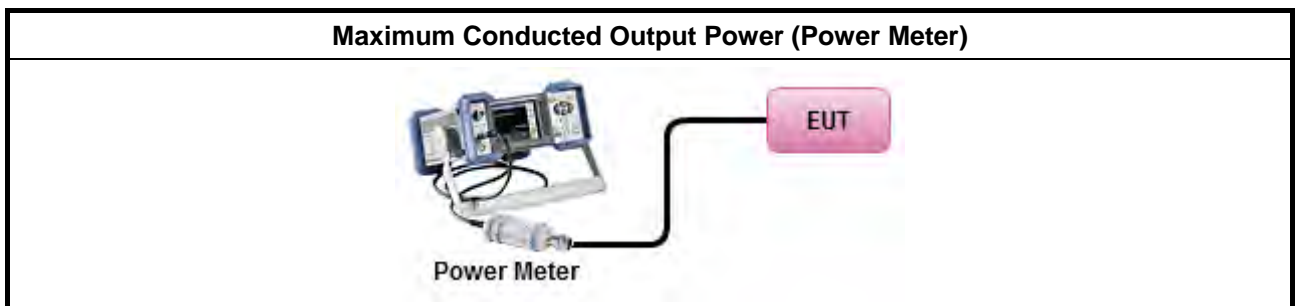

3.3.5 Test Result of Maximum Conducted Output Power

Refer as Appendix C



3.4 Power Spectral Density

3.4.1 Power Spectral Density Limit

| Power Spectral Density Limit |
|---|
| <ul style="list-style-type: none"> ▪ Power Spectral Density (PSD) \leq 8 dBm/3kHz |

3.4.2 Measuring Instruments

Refer a test equipment and calibration data table in this test report.

3.4.3 Test Procedures

| Test Method |
|--|
| <ul style="list-style-type: none"> ▪ Peak power spectral density procedures that the same method as used to determine the conducted output power. If maximum peak conducted output power was measured to demonstrate compliance to the output power limit, then the peak PSD procedure below (Method PKPSD) shall be used. If maximum conducted output power was measured to demonstrate compliance to the output power limit, then one of the average PSD procedures shall be used, as applicable based on the following criteria (the peak PSD procedure is also an acceptable option). |
| <input checked="" type="checkbox"/> Refer as FCC KDB 558074, clause 10.2 Method PKPSD (RBW=3-100kHz; Detector=peak). [duty cycle \geq 98% or external video / power trigger] |
| <input type="checkbox"/> Refer as FCC KDB 558074, clause 10.3 Method AVGPSD-1 (spectral trace averaging). |
| <input type="checkbox"/> Refer as FCC KDB 558074, clause 10.4 Method AVGPSD-2 (slow sweep speed) duty cycle < 98% and average over on/off periods with duty factor |
| <input type="checkbox"/> Refer as FCC KDB 558074, clause 10.5 Method AVGPSD-1 Alt (spectral trace averaging). |
| <input type="checkbox"/> Refer as FCC KDB 558074, clause 10.6 Method AVGPSD-2 Alt. (slow sweep speed) |
| <ul style="list-style-type: none"> ▪ For conducted measurement. |
| <ul style="list-style-type: none"> ▪ If The EUT supports multiple transmit chains using options given below: <ul style="list-style-type: none"> <input checked="" type="checkbox"/> Option 1: Measure and sum the spectra across the outputs. Refer as FCC KDB 662911, In-band power spectral density (PSD). Sample all transmit ports simultaneously using a spectrum analyzer for each transmit port. Where the trace bin-by-bin of each transmit port summing can be performed. (i.e., in the first spectral bin of output 1 is summed with that in the first spectral bin of output 2 and that from the first spectral bin of output 3, and so on up to the NTX output to obtain the value for the first frequency bin of the summed spectrum.). Add up the amplitude (power) values for the different transmit chains and use this as the new data trace. <input type="checkbox"/> Option 2: Measure and sum spectral maxima across the outputs. With this technique, spectra are measured at each output of the device at the required resolution bandwidth. The maximum value (peak) of each spectrum is determined. These maximum values are then summed mathematically in linear power units across the outputs. These operations shall be performed separately over frequency spans that have different out-of-band or spurious emission limits, <input type="checkbox"/> Option 3: Measure and add 10 log(N) dB, where N is the number of transmit chains. Refer as FCC KDB 662911, In-band power spectral density (PSD). Performed at each transmit chains and each transmit chains shall be compared with the limit have been reduced with 10 log(N). Or each transmit chains shall be add 10 log(N) to compared with the limit. |

3.4.4 Test Setup

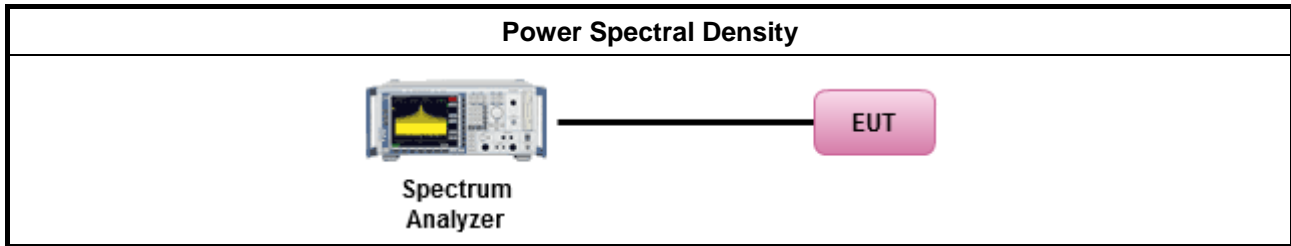

3.4.5 Test Result of Power Spectral Density

Refer as Appendix D

3.5 Emissions in Non-restricted Frequency Bands

3.5.1 Emissions in Non-restricted Frequency Bands Limit

| Un-restricted Band Emissions Limit | |
|------------------------------------|------------|
| RF output power procedure | Limit (dB) |
| Peak output power procedure | 20 |
| Average output power procedure | 30 |

Note 1: If the peak output power procedure is used to measure the fundamental emission power to demonstrate compliance to requirements, then the peak conducted output power measured within any 100 kHz outside the authorized frequency band shall be attenuated by at least 20 dB relative to the maximum measured in-band peak PSD level.

Note 2: If the average output power procedure is used to measure the fundamental emission power to demonstrate compliance to requirements, then the power in any 100 kHz outside of the authorized frequency band shall be attenuated by at least 30 dB relative to the maximum measured in-band average PSD level.

3.5.2 Measuring Instruments

Refer a test equipment and calibration data table in this test report.

3.5.3 Test Procedures

| Test Method |
|--|
| <ul style="list-style-type: none"> Refer as FCC KDB 558074, clause 11 for unwanted emissions into non-restricted bands. |

3.5.4 Test Setup

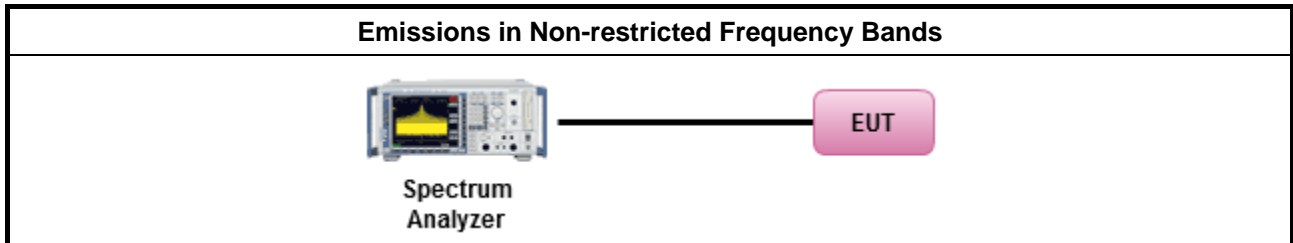

3.5.5 Test Result of Emissions in Non-restricted Frequency Bands

Refer as Appendix E

3.6 Emissions in Restricted Frequency Bands

3.6.1 Emissions in Restricted Frequency Bands Limit

| Restricted Band Emissions Limit | | | |
|---------------------------------|-----------------------|-------------------------|----------------------|
| Frequency Range (MHz) | Field Strength (uV/m) | Field Strength (dBuV/m) | Measure Distance (m) |
| 0.009~0.490 | 2400/F(kHz) | 48.5 - 13.8 | 300 |
| 0.490~1.705 | 24000/F(kHz) | 33.8 - 23 | 30 |
| 1.705~30.0 | 30 | 29 | 30 |
| 30~88 | 100 | 40 | 3 |
| 88~216 | 150 | 43.5 | 3 |
| 216~960 | 200 | 46 | 3 |
| Above 960 | 500 | 54 | 3 |

Note 1: Test distance for frequencies at or above 30 MHz, measurements may be performed at a distance other than the limit distance provided they are not performed in the near field and the emissions to be measured can be detected by the measurement equipment. When performing measurements at a distance other than that specified, the results shall be extrapolated to the specified distance using an extrapolation factor of 20 dB/decade (inverse of linear distance for field-strength measurements, inverse of linear distance-squared for power-density measurements).

Note 2: Test distance for frequencies at below 30 MHz, measurements may be performed at a distance closer than the EUT limit distance; however, an attempt should be made to avoid making measurements in the near field. When performing measurements below 30 MHz at a closer distance than the limit distance, the results shall be extrapolated to the specified distance by either making measurements at a minimum of two or more distances on at least one radial to determine the proper extrapolation factor or by using the square of an inverse linear distance extrapolation factor (40 dB/decade). The test report shall specify the extrapolation method used to determine compliance of the EUT.

Note 3: Using the distance of 1m during the test for above 18 GHz, and the test value to correct for the distance factor at 3m.

3.6.2 Measuring Instruments

Refer a test equipment and calibration data table in this test report.

3.6.3 Test Procedures

| Test Method | |
|--|--|
| <ul style="list-style-type: none"> ▪ The average emission levels shall be measured in [duty cycle ≥ 98 or duty factor]. | |
| <ul style="list-style-type: none"> ▪ Refer as ANSI C63.10, clause 6.9.2.2 band-edge testing shall be performed at the lowest frequency channel and highest frequency channel within the allowed operating band. | |
| <ul style="list-style-type: none"> ▪ For the transmitter unwanted emissions shall be measured using following options below: | |
| | <ul style="list-style-type: none"> ▪ Refer as FCC KDB 558074, clause 12 for unwanted emissions into restricted bands. |
| | <input type="checkbox"/> Refer as FCC KDB 558074, clause 12.2.5.1 Option 1 (trace averaging for duty cycle $\geq 98\%$) |
| | <input type="checkbox"/> Refer as FCC KDB 558074, clause 12.2.5.2 Option 2 (trace averaging + duty factor). |
| | <input checked="" type="checkbox"/> Refer as FCC KDB 558074, clause 12.2.5.3 Option 3 (Reduced VBW $\geq 1/T$). |
| | <input type="checkbox"/> Refer as ANSI C63.10, clause 4.2.3.2.3 (Reduced VBW). VBW $\geq 1/T$, where T is pulse time. |
| | <input type="checkbox"/> Refer as ANSI C63.10, clause 4.2.3.2.4 average value of pulsed emissions. |
| | <input checked="" type="checkbox"/> Refer as FCC KDB 558074, clause 12.2.4 measurement procedure peak limit. |
| <ul style="list-style-type: none"> ▪ For the transmitter band-edge emissions shall be measured using following options below: | |
| | <ul style="list-style-type: none"> ▪ Refer as FCC KDB 558074 clause 13.1, When the performing peak or average radiated measurements, emissions within 2 MHz of the authorized band edge may be measured using the marker-delta method described below. |
| | <ul style="list-style-type: none"> ▪ Refer as FCC KDB 558074, clause 13.2 (ANSI C63.10, clause 6.9.3) for marker-delta method for band-edge measurements. |
| | <ul style="list-style-type: none"> ▪ Refer as FCC KDB 558074, clause 13.3 for narrower resolution bandwidth (100kHz) using the band power and summing the spectral levels (i.e., 1 MHz). |
| <ul style="list-style-type: none"> ▪ For conducted and cabinet radiation measurement, refer as FCC KDB 558074, clause 12.2.2. | |
| | <ul style="list-style-type: none"> ▪ For conducted unwanted emissions into restricted bands (absolute emission limits). Devices with multiple transmit chains using options given below: (1) Measure and sum the spectra across the outputs or (2) Measure and add 10 log(N) dB |
| | <ul style="list-style-type: none"> ▪ For FCC KDB 662911 The methodology described here may overestimate array gain, thereby resulting in apparent failures to satisfy the out-of-band limits even if the device is actually compliant. In such cases, compliance may be demonstrated by performing radiated tests around the frequencies at which the apparent failures occurred. |

3.6.4 Test Setup

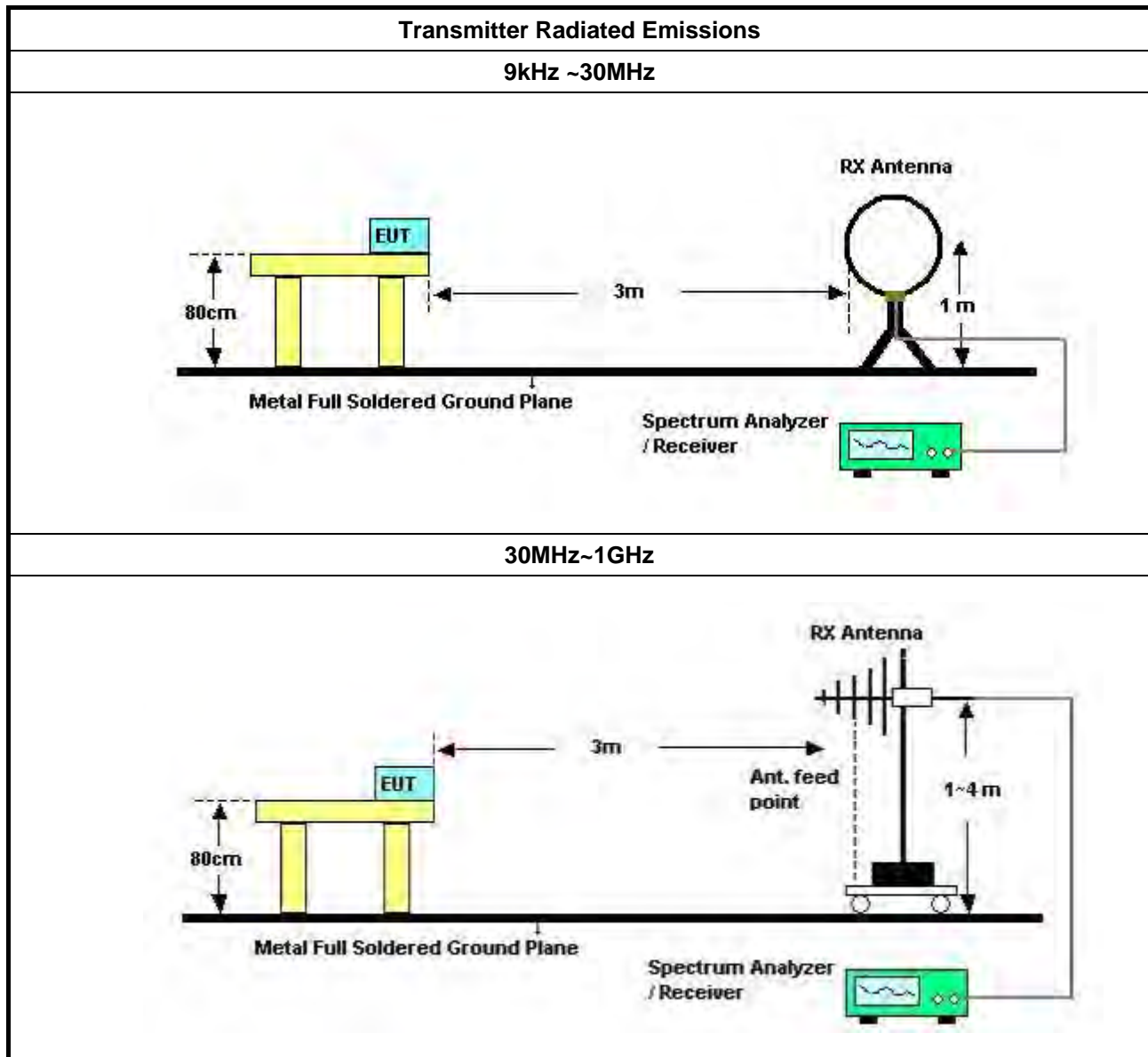

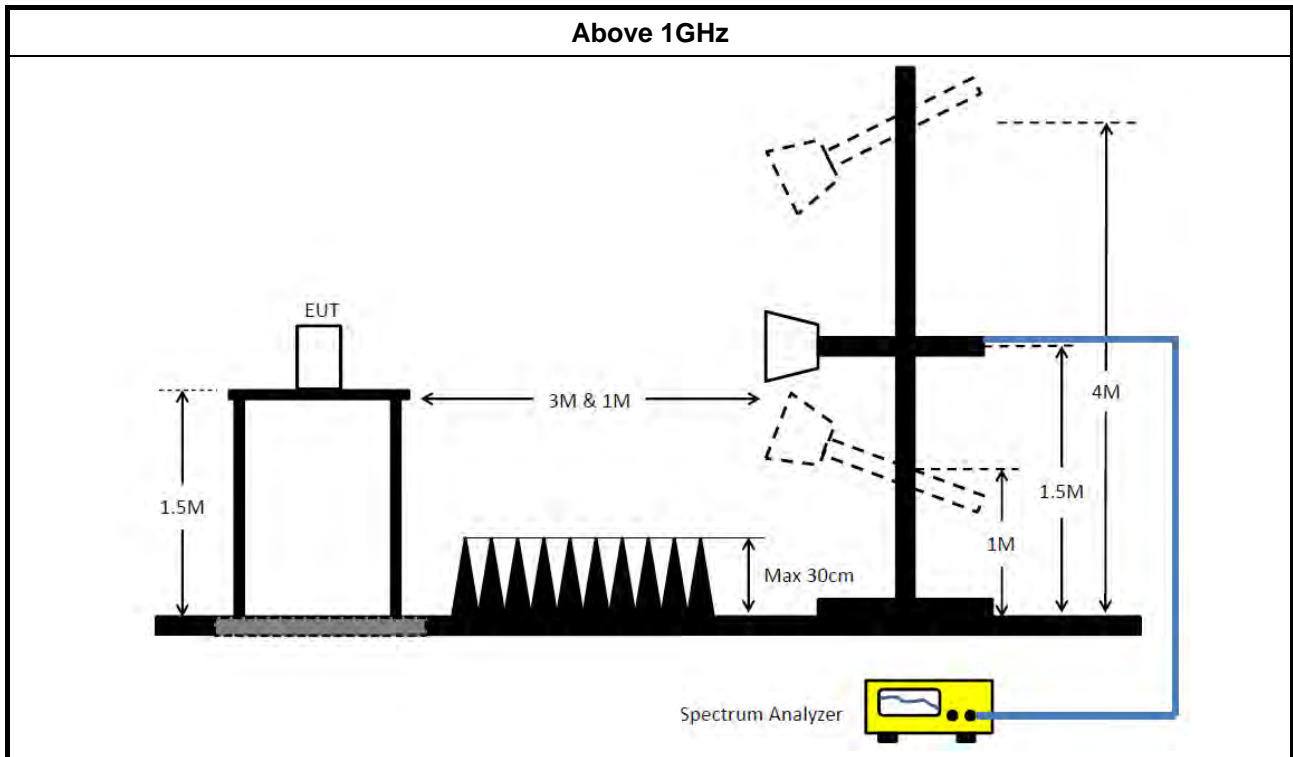

3.6.5 Transmitter Radiated Unwanted Emissions (Below 30MHz)

All amplitude of spurious emissions that are attenuated by more than 20 dB below the permissible value has no need to be reported.

3.6.6 Test Result of Transmitter Radiated Unwanted Emissions

Refer as Appendix F



4 Test Equipment and Calibration Data

| Instrument | Manufacturer | Model No. | Serial No. | Characteristics | Calibration Date | Calibration Due Date | Remark |
|-----------------------------------|--------------|-------------------|------------------|-----------------|------------------|----------------------|-----------------------|
| EMI Receiver | Agilent | N9038A | My52260123 | 9kHz ~ 8.45GHz | Jan. 23, 2017 | Jan. 22, 2018 | Conduction (CO01-CB) |
| LISN | F.C.C. | FCC-LISN-50-16-2 | 04083 | 150kHz ~ 100MHz | Dec. 14, 2016 | Dec. 13, 2017 | Conduction (CO01-CB) |
| LISN | Schwarzbeck | NSLK 8127 | 8127647 | 9kHz ~ 30MHz | Dec. 21, 2016 | Dec. 20, 2017 | Conduction (CO01-CB) |
| COND Cable | Woken | Cable | 01 | 150kHz ~ 30MHz | May 23, 2017 | May 22, 2018 | Conduction (CO01-CB) |
| Software | Audix | E3 | 6.120210n | - | N.C.R. | N.C.R. | Conduction (CO01-CB) |
| BILOG ANTENNA with 6dB Attenuator | TESEQ & EMCI | CBL6112D & N-6-06 | 37880 & AT-N0609 | 20MHz ~ 2GHz | Aug. 30, 2017 | Aug. 29, 2018 | Radiation (03CH01-CB) |
| Horn Antenna | EMCO | 3115 | 00075790 | 750MHz ~ 18GHz | Nov. 10, 2016 | Nov. 09, 2017 | Radiation (03CH01-CB) |
| Horn Antenna | Schwarzbeck | BBHA 9170 | BBHA9170507 | 15GHz ~ 40GHz | Jun. 16, 2017 | Jun. 15, 2018 | Radiation (03CH01-CB) |
| Pre-Amplifier | EMCI | EMC330N | 980332 | 20MHz ~ 3GHz | May 02, 2017 | May 01, 2018 | Radiation (03CH01-CB) |
| Pre-Amplifier | Agilent | 8449B | 3008A02310 | 1GHz ~ 26.5GHz | Jan. 16, 2017 | Jan. 15, 2018 | Radiation (03CH01-CB) |
| Pre-Amplifier | - | - | TF-130N-R1 | 26GHz ~ 40GHz | Jun. 20, 2017 | Jun. 19, 2018 | Radiation (03CH01-CB) |
| Spectrum Analyzer | R&S | FSP40 | 100056 | 9kHz ~ 40GHz | Nov. 22, 2016 | Nov. 21, 2017 | Radiation (03CH01-CB) |
| Loop Antenna | Teseq | HLA 6120 | 24155 | 9kHz - 30 MHz | Mar. 16, 2016* | Mar. 15, 2018* | Radiation (03CH01-CB) |
| EMI Test | R&S | ESCS | 100355 | 9kHz ~ 2.75GHz | May 06, 2017 | May 05, 2018 | Radiation (03CH01-CB) |
| RF Cable-low | Woken | Low Cable-16+17 | N/A | 30 MHz ~ 1 GHz | Oct. 24, 2016 | Oct. 23, 2017 | Radiation (03CH01-CB) |
| RF Cable-high | Woken | High Cable-16 | N/A | 1 GHz ~ 18 GHz | Oct. 24, 2016 | Oct. 23, 2017 | Radiation (03CH01-CB) |
| RF Cable-high | Woken | High Cable-16+17 | N/A | 1 GHz ~ 18 GHz | Oct. 24, 2016 | Oct. 23, 2017 | Radiation (03CH01-CB) |
| RF Cable-high | Woken | High Cable-40G#1 | N/A | 18GHz ~ 40 GHz | Oct. 24, 2016 | Oct. 23, 2017 | Radiation (03CH01-CB) |
| RF Cable-high | Woken | High Cable-40G#2 | N/A | 18GHz ~ 40 GHz | Oct. 24, 2016 | Oct. 23, 2017 | Radiation (03CH01-CB) |



| Instrument | Manufacturer | Model No. | Serial No. | Characteristics | Calibration Date | Calibration Due Date | Remark |
|-------------------|--------------|-----------|---------------|------------------|------------------|----------------------|-----------------------|
| Test Software | Audix | E3 | 6.2009-10-7 | N/A | N/A | N/A | Radiation (03CH01-CB) |
| Spectrum analyzer | R&S | FSV40 | 100979 | 9kHz~40GHz | Dec. 26, 2016 | Dec. 25, 2017 | Conducted (TH01-CB) |
| RF Cable-high | Woken | RG402 | High Cable-6 | 1 GHz – 26.5 GHz | Oct. 24, 2016 | Oct. 23, 2017 | Conducted (TH01-CB) |
| RF Cable-high | Woken | RG402 | High Cable-7 | 1 GHz –26.5 GHz | Oct. 24, 2016 | Oct. 23, 2017 | Conducted (TH01-CB) |
| RF Cable-high | Woken | RG402 | High Cable-8 | 1 GHz –26.5 GHz | Oct. 24, 2016 | Oct. 23, 2017 | Conducted (TH01-CB) |
| RF Cable-high | Woken | RG402 | High Cable-9 | 1 GHz –26.5 GHz | Oct. 24, 2016 | Oct. 23, 2017 | Conducted (TH01-CB) |
| RF Cable-high | Woken | RG402 | High Cable-10 | 1 GHz –26.5 GHz | Oct. 24, 2016 | Oct. 23, 2017 | Conducted (TH01-CB) |
| Power Sensor | Agilent | U2021XA | MY53410001 | 50MHz~18GHz | Nov. 22, 2016 | Nov. 21, 2017 | Conducted (TH01-CB) |

Note: Calibration Interval of instruments listed above is one year.

“**” Calibration Interval of instruments listed above is two years.

NCR means Non-Calibration required.



AC Power-line Conducted Emissions Result

Appendix A

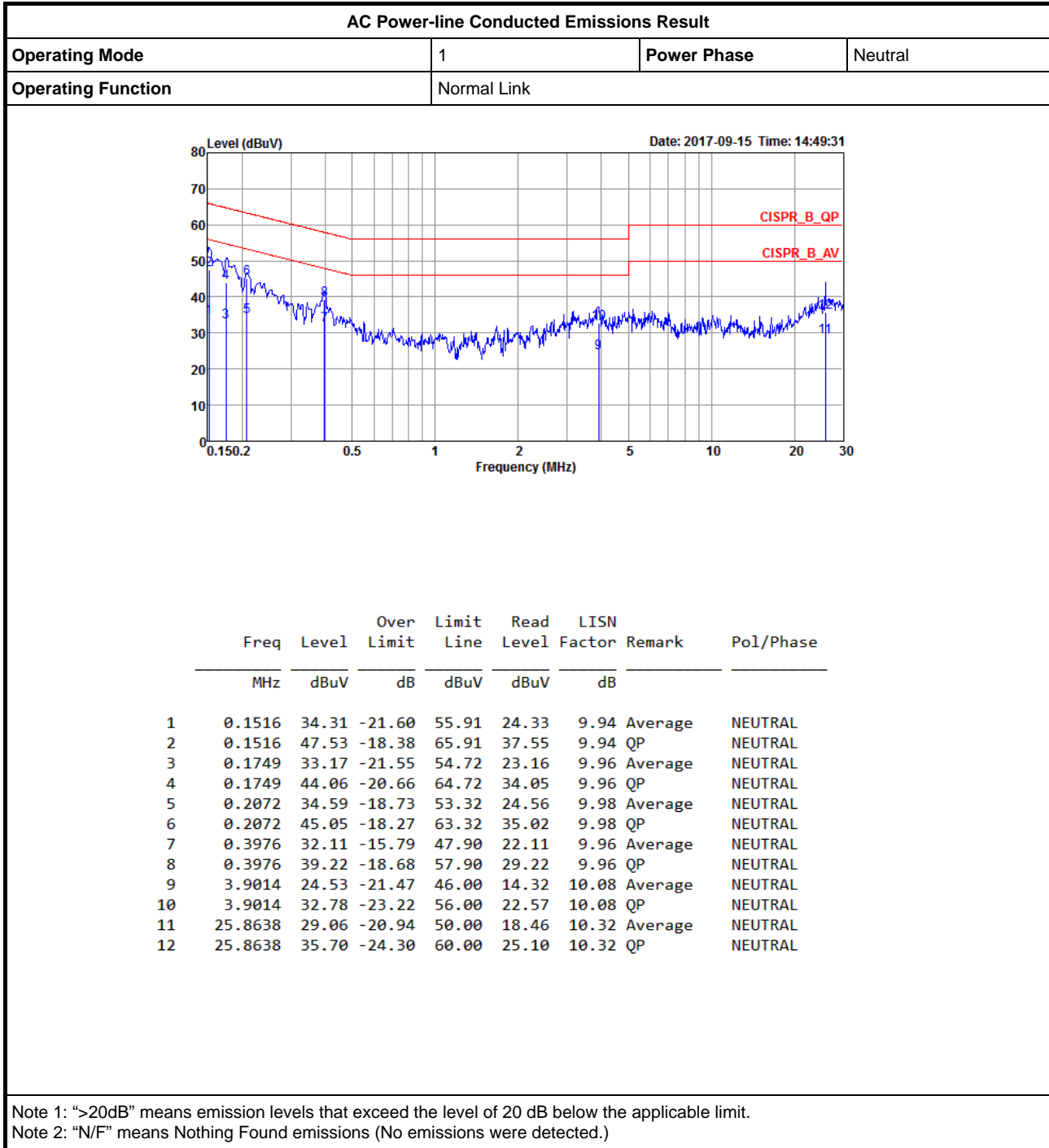



AC Power-line Conducted Emissions Result

Appendix A

| AC Power-line Conducted Emissions Result | | | | | | | | | | | | | | | | | | | | | | | | | | | | | | | | | | | | | | | | | | | | | | | | | | | | | | | | | | | | | | | | | | | | | | | | | | | | | | | | | | | | | | | | | | | | | | | | | | | | | | | | | | | | | | | | | | | | | | | | | | | | | | | | | |
|--|-------------|-------------|------------|------------|------------|-------------|------------|------------|------------|-------------|--------|-----------|--|-----|------|----|------|------|----|--|--|---|--------|-------|--------|-------|-------|------|---------|------|---|--------|-------|--------|-------|-------|------|----|------|---|--------|-------|--------|-------|-------|------|---------|------|---|--------|-------|--------|-------|-------|------|----|------|---|--------|-------|--------|-------|-------|------|---------|------|---|--------|-------|--------|-------|-------|------|----|------|---|--------|-------|--------|-------|-------|------|---------|------|---|--------|-------|--------|-------|-------|------|----|------|---|--------|-------|--------|-------|-------|------|---------|------|----|--------|-------|--------|-------|-------|------|----|------|----|---------|-------|--------|-------|-------|-------|---------|------|----|---------|-------|--------|-------|-------|-------|----|------|
| Operating Mode | 1 | Power Phase | Line | | | | | | | | | | | | | | | | | | | | | | | | | | | | | | | | | | | | | | | | | | | | | | | | | | | | | | | | | | | | | | | | | | | | | | | | | | | | | | | | | | | | | | | | | | | | | | | | | | | | | | | | | | | | | | | | | | | | | | | | | | | | | | |
| Operating Function | Normal Link | | | | | | | | | | | | | | | | | | | | | | | | | | | | | | | | | | | | | | | | | | | | | | | | | | | | | | | | | | | | | | | | | | | | | | | | | | | | | | | | | | | | | | | | | | | | | | | | | | | | | | | | | | | | | | | | | | | | | | | | | | | | | | | | |
| <p>The graph displays the AC power-line conducted emissions. The y-axis represents Level in dBuV (0 to 80), and the x-axis represents Frequency in MHz (0.150.2 to 30). Two red lines indicate the CISPR limits: CISPR_B_QP (Quasi-Peak) and CISPR_B_AV (Average). The test data is shown as a blue line with several peaks marked by vertical lines and numbered 1 through 12. The date and time of the test are 2017-09-15 at 14:52:45.</p> | | | | | | | | | | | | | | | | | | | | | | | | | | | | | | | | | | | | | | | | | | | | | | | | | | | | | | | | | | | | | | | | | | | | | | | | | | | | | | | | | | | | | | | | | | | | | | | | | | | | | | | | | | | | | | | | | | | | | | | | | | | | | | | | | |
| <table border="1"> <thead> <tr> <th></th> <th>Freq</th> <th>Level</th> <th>Over Limit</th> <th>Limit Line</th> <th>Read Level</th> <th>LISN Factor</th> <th>Remark</th> <th>Pol/Phase</th> </tr> <tr> <th></th> <th>MHz</th> <th>dBuV</th> <th>dB</th> <th>dBuV</th> <th>dBuV</th> <th>dB</th> <th></th> <th></th> </tr> </thead> <tbody> <tr> <td>1</td> <td>0.1506</td> <td>34.47</td> <td>-21.50</td> <td>55.97</td> <td>24.48</td> <td>9.95</td> <td>Average</td> <td>LINE</td> </tr> <tr> <td>2</td> <td>0.1506</td> <td>46.52</td> <td>-19.45</td> <td>65.97</td> <td>36.53</td> <td>9.95</td> <td>QP</td> <td>LINE</td> </tr> <tr> <td>3</td> <td>0.1596</td> <td>36.91</td> <td>-18.57</td> <td>55.48</td> <td>26.92</td> <td>9.95</td> <td>Average</td> <td>LINE</td> </tr> <tr> <td>4</td> <td>0.1596</td> <td>48.36</td> <td>-17.12</td> <td>65.48</td> <td>38.37</td> <td>9.95</td> <td>QP</td> <td>LINE</td> </tr> <tr> <td>5</td> <td>0.1825</td> <td>35.39</td> <td>-18.98</td> <td>54.37</td> <td>25.40</td> <td>9.94</td> <td>Average</td> <td>LINE</td> </tr> <tr> <td>6</td> <td>0.1825</td> <td>46.04</td> <td>-18.33</td> <td>64.37</td> <td>36.05</td> <td>9.94</td> <td>QP</td> <td>LINE</td> </tr> <tr> <td>7</td> <td>0.3997</td> <td>33.83</td> <td>-14.03</td> <td>47.86</td> <td>23.90</td> <td>9.89</td> <td>Average</td> <td>LINE</td> </tr> <tr> <td>8</td> <td>0.3997</td> <td>40.66</td> <td>-17.20</td> <td>57.86</td> <td>30.73</td> <td>9.89</td> <td>QP</td> <td>LINE</td> </tr> <tr> <td>9</td> <td>3.9639</td> <td>27.03</td> <td>-18.97</td> <td>46.00</td> <td>16.95</td> <td>9.95</td> <td>Average</td> <td>LINE</td> </tr> <tr> <td>10</td> <td>3.9639</td> <td>36.68</td> <td>-19.32</td> <td>56.00</td> <td>26.60</td> <td>9.95</td> <td>QP</td> <td>LINE</td> </tr> <tr> <td>11</td> <td>25.8638</td> <td>29.21</td> <td>-20.79</td> <td>50.00</td> <td>18.61</td> <td>10.32</td> <td>Average</td> <td>LINE</td> </tr> <tr> <td>12</td> <td>25.8638</td> <td>35.78</td> <td>-24.22</td> <td>60.00</td> <td>25.18</td> <td>10.32</td> <td>QP</td> <td>LINE</td> </tr> </tbody> </table> | | | | | Freq | Level | Over Limit | Limit Line | Read Level | LISN Factor | Remark | Pol/Phase | | MHz | dBuV | dB | dBuV | dBuV | dB | | | 1 | 0.1506 | 34.47 | -21.50 | 55.97 | 24.48 | 9.95 | Average | LINE | 2 | 0.1506 | 46.52 | -19.45 | 65.97 | 36.53 | 9.95 | QP | LINE | 3 | 0.1596 | 36.91 | -18.57 | 55.48 | 26.92 | 9.95 | Average | LINE | 4 | 0.1596 | 48.36 | -17.12 | 65.48 | 38.37 | 9.95 | QP | LINE | 5 | 0.1825 | 35.39 | -18.98 | 54.37 | 25.40 | 9.94 | Average | LINE | 6 | 0.1825 | 46.04 | -18.33 | 64.37 | 36.05 | 9.94 | QP | LINE | 7 | 0.3997 | 33.83 | -14.03 | 47.86 | 23.90 | 9.89 | Average | LINE | 8 | 0.3997 | 40.66 | -17.20 | 57.86 | 30.73 | 9.89 | QP | LINE | 9 | 3.9639 | 27.03 | -18.97 | 46.00 | 16.95 | 9.95 | Average | LINE | 10 | 3.9639 | 36.68 | -19.32 | 56.00 | 26.60 | 9.95 | QP | LINE | 11 | 25.8638 | 29.21 | -20.79 | 50.00 | 18.61 | 10.32 | Average | LINE | 12 | 25.8638 | 35.78 | -24.22 | 60.00 | 25.18 | 10.32 | QP | LINE |
| | Freq | Level | Over Limit | Limit Line | Read Level | LISN Factor | Remark | Pol/Phase | | | | | | | | | | | | | | | | | | | | | | | | | | | | | | | | | | | | | | | | | | | | | | | | | | | | | | | | | | | | | | | | | | | | | | | | | | | | | | | | | | | | | | | | | | | | | | | | | | | | | | | | | | | | | | | | | | | | | | | | | |
| | MHz | dBuV | dB | dBuV | dBuV | dB | | | | | | | | | | | | | | | | | | | | | | | | | | | | | | | | | | | | | | | | | | | | | | | | | | | | | | | | | | | | | | | | | | | | | | | | | | | | | | | | | | | | | | | | | | | | | | | | | | | | | | | | | | | | | | | | | | | | | | | | | | | |
| 1 | 0.1506 | 34.47 | -21.50 | 55.97 | 24.48 | 9.95 | Average | LINE | | | | | | | | | | | | | | | | | | | | | | | | | | | | | | | | | | | | | | | | | | | | | | | | | | | | | | | | | | | | | | | | | | | | | | | | | | | | | | | | | | | | | | | | | | | | | | | | | | | | | | | | | | | | | | | | | | | | | | | | | |
| 2 | 0.1506 | 46.52 | -19.45 | 65.97 | 36.53 | 9.95 | QP | LINE | | | | | | | | | | | | | | | | | | | | | | | | | | | | | | | | | | | | | | | | | | | | | | | | | | | | | | | | | | | | | | | | | | | | | | | | | | | | | | | | | | | | | | | | | | | | | | | | | | | | | | | | | | | | | | | | | | | | | | | | | |
| 3 | 0.1596 | 36.91 | -18.57 | 55.48 | 26.92 | 9.95 | Average | LINE | | | | | | | | | | | | | | | | | | | | | | | | | | | | | | | | | | | | | | | | | | | | | | | | | | | | | | | | | | | | | | | | | | | | | | | | | | | | | | | | | | | | | | | | | | | | | | | | | | | | | | | | | | | | | | | | | | | | | | | | | |
| 4 | 0.1596 | 48.36 | -17.12 | 65.48 | 38.37 | 9.95 | QP | LINE | | | | | | | | | | | | | | | | | | | | | | | | | | | | | | | | | | | | | | | | | | | | | | | | | | | | | | | | | | | | | | | | | | | | | | | | | | | | | | | | | | | | | | | | | | | | | | | | | | | | | | | | | | | | | | | | | | | | | | | | | |
| 5 | 0.1825 | 35.39 | -18.98 | 54.37 | 25.40 | 9.94 | Average | LINE | | | | | | | | | | | | | | | | | | | | | | | | | | | | | | | | | | | | | | | | | | | | | | | | | | | | | | | | | | | | | | | | | | | | | | | | | | | | | | | | | | | | | | | | | | | | | | | | | | | | | | | | | | | | | | | | | | | | | | | | | |
| 6 | 0.1825 | 46.04 | -18.33 | 64.37 | 36.05 | 9.94 | QP | LINE | | | | | | | | | | | | | | | | | | | | | | | | | | | | | | | | | | | | | | | | | | | | | | | | | | | | | | | | | | | | | | | | | | | | | | | | | | | | | | | | | | | | | | | | | | | | | | | | | | | | | | | | | | | | | | | | | | | | | | | | | |
| 7 | 0.3997 | 33.83 | -14.03 | 47.86 | 23.90 | 9.89 | Average | LINE | | | | | | | | | | | | | | | | | | | | | | | | | | | | | | | | | | | | | | | | | | | | | | | | | | | | | | | | | | | | | | | | | | | | | | | | | | | | | | | | | | | | | | | | | | | | | | | | | | | | | | | | | | | | | | | | | | | | | | | | | |
| 8 | 0.3997 | 40.66 | -17.20 | 57.86 | 30.73 | 9.89 | QP | LINE | | | | | | | | | | | | | | | | | | | | | | | | | | | | | | | | | | | | | | | | | | | | | | | | | | | | | | | | | | | | | | | | | | | | | | | | | | | | | | | | | | | | | | | | | | | | | | | | | | | | | | | | | | | | | | | | | | | | | | | | | |
| 9 | 3.9639 | 27.03 | -18.97 | 46.00 | 16.95 | 9.95 | Average | LINE | | | | | | | | | | | | | | | | | | | | | | | | | | | | | | | | | | | | | | | | | | | | | | | | | | | | | | | | | | | | | | | | | | | | | | | | | | | | | | | | | | | | | | | | | | | | | | | | | | | | | | | | | | | | | | | | | | | | | | | | | |
| 10 | 3.9639 | 36.68 | -19.32 | 56.00 | 26.60 | 9.95 | QP | LINE | | | | | | | | | | | | | | | | | | | | | | | | | | | | | | | | | | | | | | | | | | | | | | | | | | | | | | | | | | | | | | | | | | | | | | | | | | | | | | | | | | | | | | | | | | | | | | | | | | | | | | | | | | | | | | | | | | | | | | | | | |
| 11 | 25.8638 | 29.21 | -20.79 | 50.00 | 18.61 | 10.32 | Average | LINE | | | | | | | | | | | | | | | | | | | | | | | | | | | | | | | | | | | | | | | | | | | | | | | | | | | | | | | | | | | | | | | | | | | | | | | | | | | | | | | | | | | | | | | | | | | | | | | | | | | | | | | | | | | | | | | | | | | | | | | | | |
| 12 | 25.8638 | 35.78 | -24.22 | 60.00 | 25.18 | 10.32 | QP | LINE | | | | | | | | | | | | | | | | | | | | | | | | | | | | | | | | | | | | | | | | | | | | | | | | | | | | | | | | | | | | | | | | | | | | | | | | | | | | | | | | | | | | | | | | | | | | | | | | | | | | | | | | | | | | | | | | | | | | | | | | | |
| <p>Note 1: ">20dB" means emission levels that exceed the level of 20 dB below the applicable limit. Note 2: "N/F" means Nothing Found emissions (No emissions were detected.)</p> | | | | | | | | | | | | | | | | | | | | | | | | | | | | | | | | | | | | | | | | | | | | | | | | | | | | | | | | | | | | | | | | | | | | | | | | | | | | | | | | | | | | | | | | | | | | | | | | | | | | | | | | | | | | | | | | | | | | | | | | | | | | | | | | | |



Summary

| Mode | Max-N dB (Hz) | Max-OBW (Hz) | ITU-Code | Min-N dB (Hz) | Min-OBW (Hz) |
|------------------------------|------------------|-----------------|----------|------------------|-----------------|
| 2.4-2.4835GHz | - | - | - | - | - |
| 802.11b_Nss1,(1Mbps)_2TX | 7.05M | 11.869M | 11M9G1D | 6.55M | 11.419M |
| 802.11g_Nss1,(6Mbps)_2TX | 15.05M | 18.416M | 18M4D1D | 13.75M | 16.192M |
| 802.11n HT20_Nss1,(MCS0)_2TX | 16.025M | 23.113M | 23M1D1D | 12.575M | 17.316M |
| 802.11n HT40_Nss1,(MCS0)_2TX | 33.75M | 35.832M | 35M8D1D | 28.75M | 35.732M |

Max-N dB = Maximum 6dB down bandwidth; **Max-OBW** = Maximum 99% occupied bandwidth;
Min-N dB = Minimum 6dB down bandwidth; **Min-OBW** = Minimum 99% occupied bandwidth;

Result

| Mode | Result | Limit (Hz) | Port 1-N dB (Hz) | Port 1-OBW (Hz) | Port 2-N dB (Hz) | Port 2-OBW (Hz) |
|------------------------------|--------|---------------|---------------------|--------------------|---------------------|--------------------|
| 802.11b_Nss1,(1Mbps)_2TX | - | - | - | - | - | - |
| 2412MHz | Pass | 500k | 6.975M | 11.419M | 7.025M | 11.819M |
| 2437MHz | Pass | 500k | 6.55M | 11.719M | 7.025M | 11.869M |
| 2462MHz | Pass | 500k | 7.05M | 11.769M | 7.025M | 11.844M |
| 802.11g_Nss1,(6Mbps)_2TX | - | - | - | - | - | - |
| 2412MHz | Pass | 500k | 15M | 16.217M | 15.05M | 16.217M |
| 2437MHz | Pass | 500k | 14.375M | 18.416M | 15.025M | 16.717M |
| 2462MHz | Pass | 500k | 13.75M | 16.242M | 14.625M | 16.192M |
| 802.11n HT20_Nss1,(MCS0)_2TX | - | - | - | - | - | - |
| 2412MHz | Pass | 500k | 13.825M | 17.366M | 15.05M | 17.391M |
| 2437MHz | Pass | 500k | 16.025M | 23.113M | 14.05M | 19.89M |
| 2462MHz | Pass | 500k | 15.025M | 17.341M | 12.575M | 17.316M |
| 802.11n HT40_Nss1,(MCS0)_2TX | - | - | - | - | - | - |
| 2422MHz | Pass | 500k | 31.2M | 35.832M | 33.75M | 35.832M |
| 2437MHz | Pass | 500k | 33.75M | 35.732M | 30M | 35.832M |
| 2452MHz | Pass | 500k | 30.1M | 35.832M | 28.75M | 35.732M |

Port X-N dB = Port X 6dB down bandwidth; **Port X-OBW** = Port X 99% occupied bandwidth;

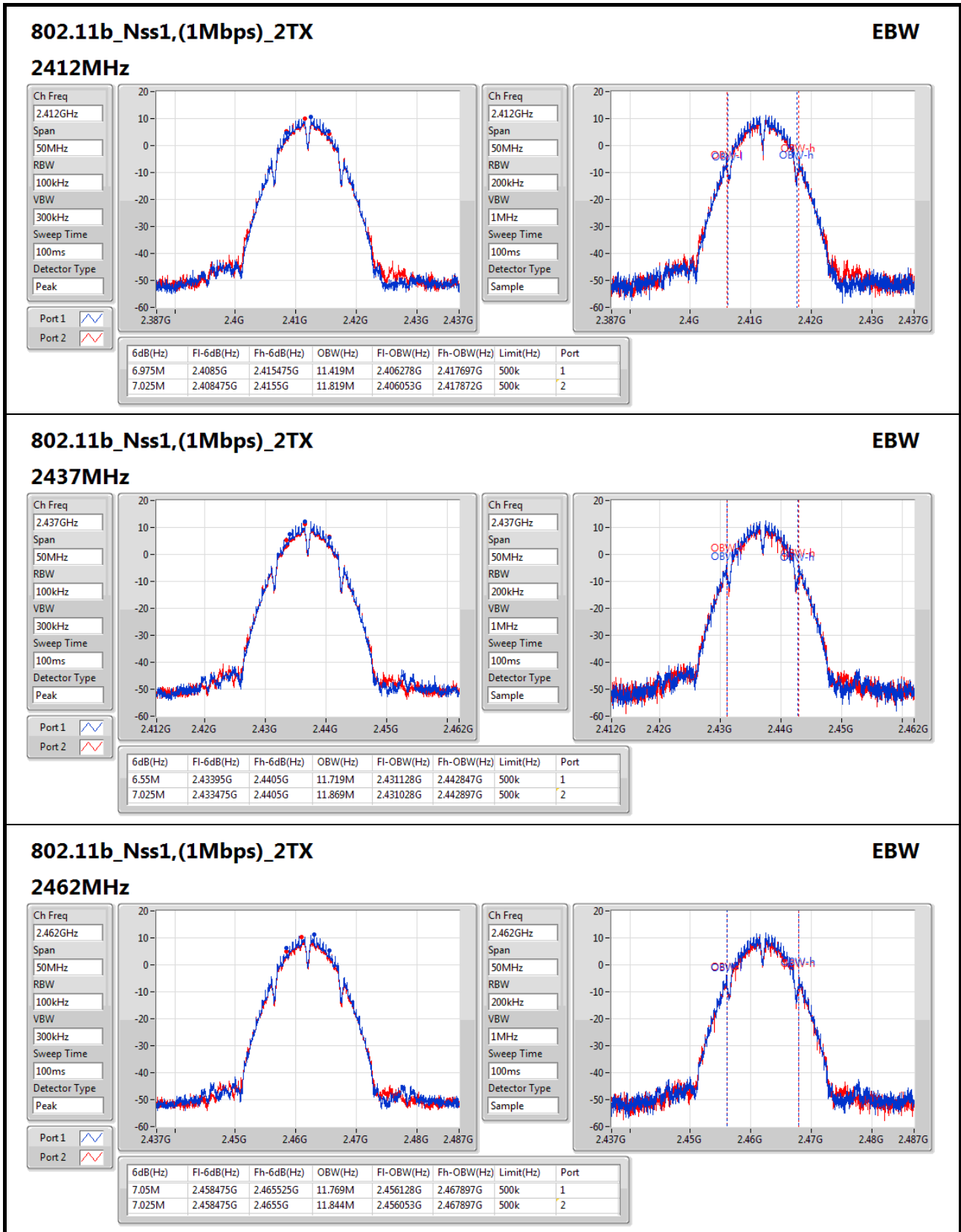

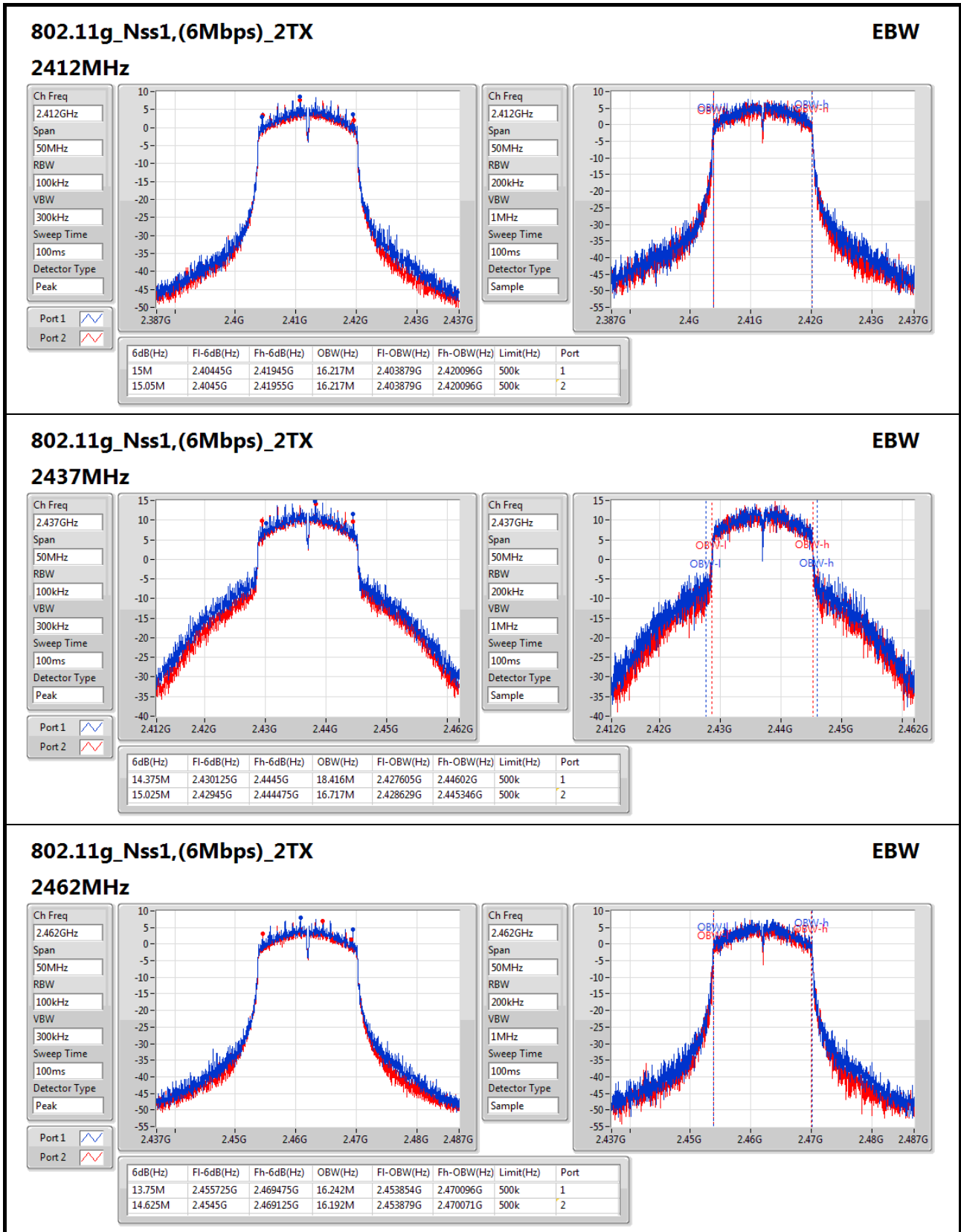

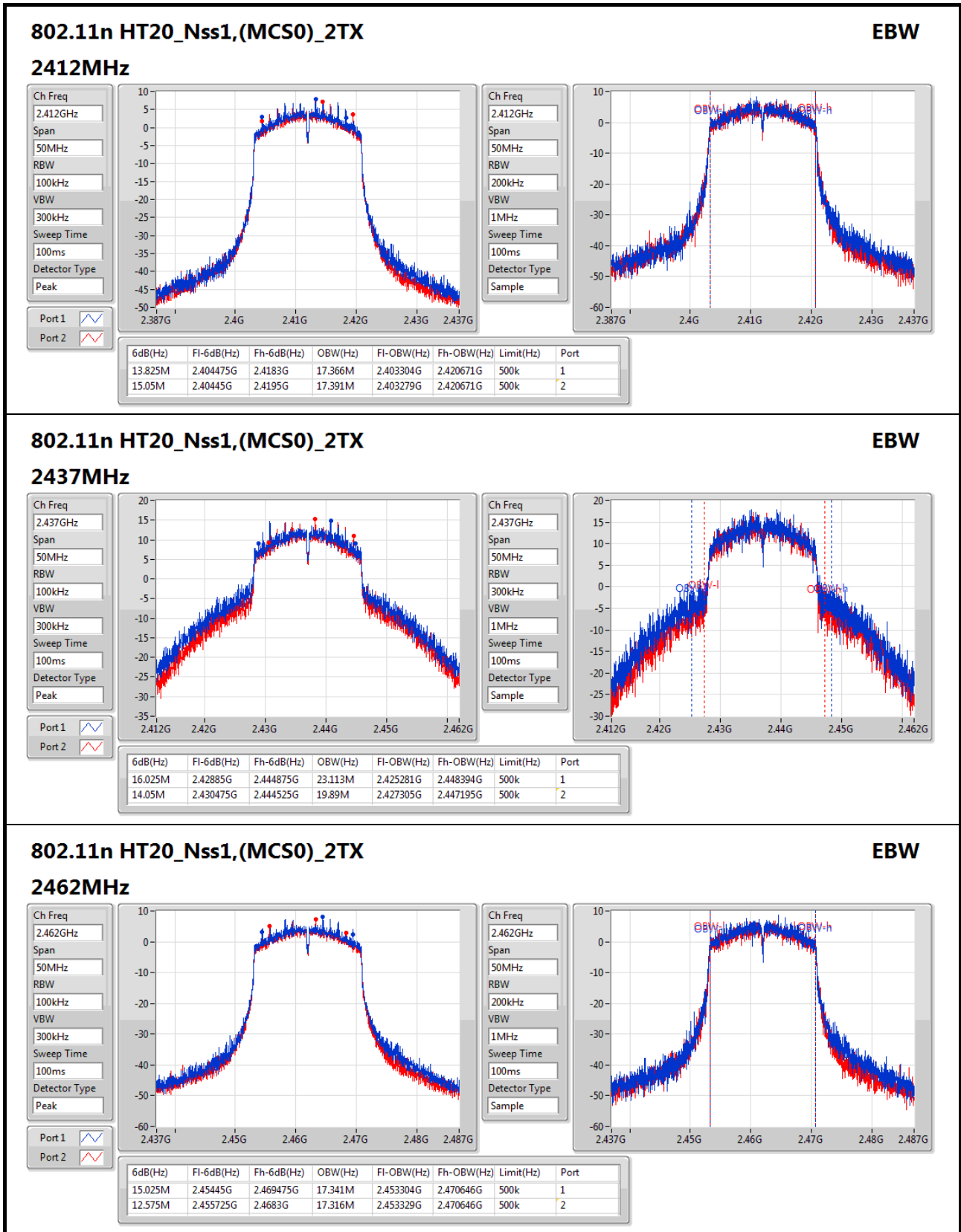

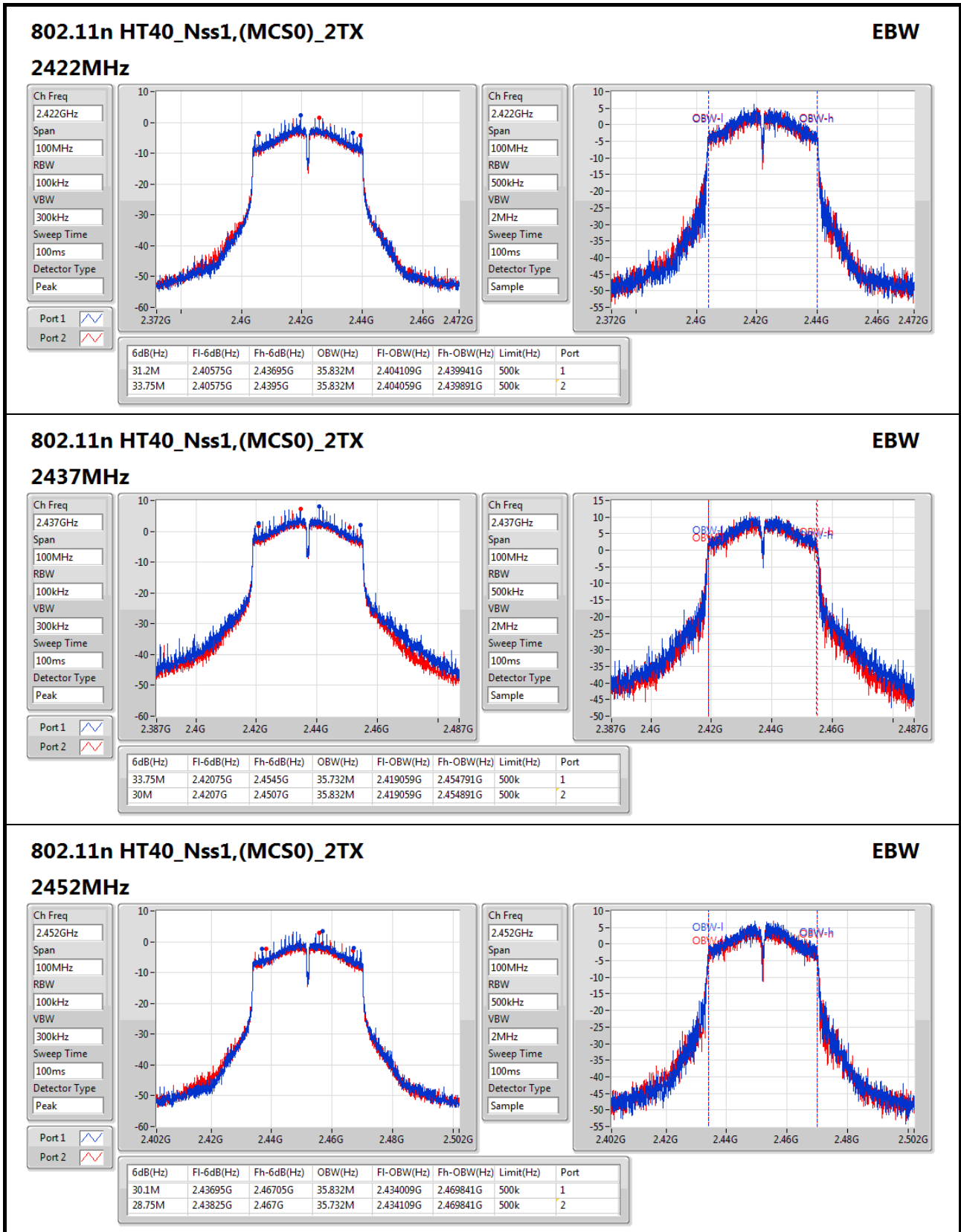



Summary

| Mode | Total Power (dBm) | Total Power (W) |
|------------------------------|-------------------|-----------------|
| 2.4-2.4835GHz | - | - |
| 802.11b_Nss1,(1Mbps)_2TX | 22.89 | 0.19454 |
| 802.11g_Nss1,(6Mbps)_2TX | 28.19 | 0.65917 |
| 802.11n HT20_Nss1,(MCS0)_2TX | 29.06 | 0.80538 |
| 802.11n HT40_Nss1,(MCS0)_2TX | 23.01 | 0.19999 |

Result

| Mode | Result | DG (dBi) | Port 1 (dBm) | Port 2 (dBm) | Total Power (dBm) | Power Limit (dBm) |
|------------------------------|--------|----------|--------------|--------------|-------------------|-------------------|
| 802.11b_Nss1,(1Mbps)_2TX | - | - | - | - | - | - |
| 2412MHz | Pass | 3.36 | 19.16 | 18.56 | 21.88 | 30.00 |
| 2437MHz | Pass | 3.36 | 20.18 | 19.55 | 22.89 | 30.00 |
| 2462MHz | Pass | 3.36 | 19.52 | 18.74 | 22.16 | 30.00 |
| 802.11g_Nss1,(6Mbps)_2TX | - | - | - | - | - | - |
| 2412MHz | Pass | 3.36 | 19.13 | 18.57 | 21.87 | 30.00 |
| 2437MHz | Pass | 3.36 | 25.43 | 24.91 | 28.19 | 30.00 |
| 2462MHz | Pass | 3.36 | 18.83 | 18.02 | 21.45 | 30.00 |
| 802.11n HT20_Nss1,(MCS0)_2TX | - | - | - | - | - | - |
| 2412MHz | Pass | 3.36 | 18.64 | 18.09 | 21.38 | 30.00 |
| 2437MHz | Pass | 3.36 | 26.30 | 25.79 | 29.06 | 30.00 |
| 2462MHz | Pass | 3.36 | 18.76 | 18.12 | 21.46 | 30.00 |
| 802.11n HT40_Nss1,(MCS0)_2TX | - | - | - | - | - | - |
| 2422MHz | Pass | 3.36 | 14.79 | 14.31 | 17.57 | 30.00 |
| 2437MHz | Pass | 3.36 | 20.31 | 19.66 | 23.01 | 30.00 |
| 2452MHz | Pass | 3.36 | 16.24 | 15.56 | 18.92 | 30.00 |

DG = Directional Gain; Port X = Port X output power



Summary

| Mode | PD (dBm/RBW) |
|------------------------------|-----------------|
| 2.4-2.4835GHz | - |
| 802.11b_Nss1,(1Mbps)_2TX | -0.69 |
| 802.11g_Nss1,(6Mbps)_2TX | 1.35 |
| 802.11n HT20_Nss1,(MCS0)_2TX | 2.06 |
| 802.11n HT40_Nss1,(MCS0)_2TX | -6.43 |

RBW=3kHz.

Result

| Mode | Result | DG (dBi) | Port 1 (dBm/RBW) | Port 2 (dBm/RBW) | PD (dBm/RBW) | PD Limit (dBm/RBW) |
|------------------------------|--------|-------------|---------------------|---------------------|-----------------|-----------------------|
| 802.11b_Nss1,(1Mbps)_2TX | - | - | - | - | - | - |
| 2412MHz | Pass | 6.37 | -3.58 | -4.48 | -2.60 | 7.63 |
| 2437MHz | Pass | 6.37 | -2.60 | -1.97 | -0.69 | 7.63 |
| 2462MHz | Pass | 6.37 | -4.21 | -3.91 | -1.92 | 7.63 |
| 802.11g_Nss1,(6Mbps)_2TX | - | - | - | - | - | - |
| 2412MHz | Pass | 6.37 | -5.34 | -6.53 | -5.15 | 7.63 |
| 2437MHz | Pass | 6.37 | -0.28 | -0.18 | 1.35 | 7.63 |
| 2462MHz | Pass | 6.37 | -6.49 | -7.43 | -5.77 | 7.63 |
| 802.11n HT20_Nss1,(MCS0)_2TX | - | - | - | - | - | - |
| 2412MHz | Pass | 6.37 | -6.58 | -7.16 | -5.31 | 7.63 |
| 2437MHz | Pass | 6.37 | 1.23 | 0.11 | 2.06 | 7.63 |
| 2462MHz | Pass | 6.37 | -7.10 | -6.89 | -5.72 | 7.63 |
| 802.11n HT40_Nss1,(MCS0)_2TX | - | - | - | - | - | - |
| 2422MHz | Pass | 6.37 | -12.06 | -13.23 | -11.09 | 7.63 |
| 2437MHz | Pass | 6.37 | -7.11 | -7.55 | -6.43 | 7.63 |
| 2452MHz | Pass | 6.37 | -10.68 | -11.89 | -10.12 | 7.63 |

DG = Directional Gain; RBW=3kHz;

PD = trace bin-by-bin of each transmits port summing can be performed maximum power density; Port X = Port X power density;

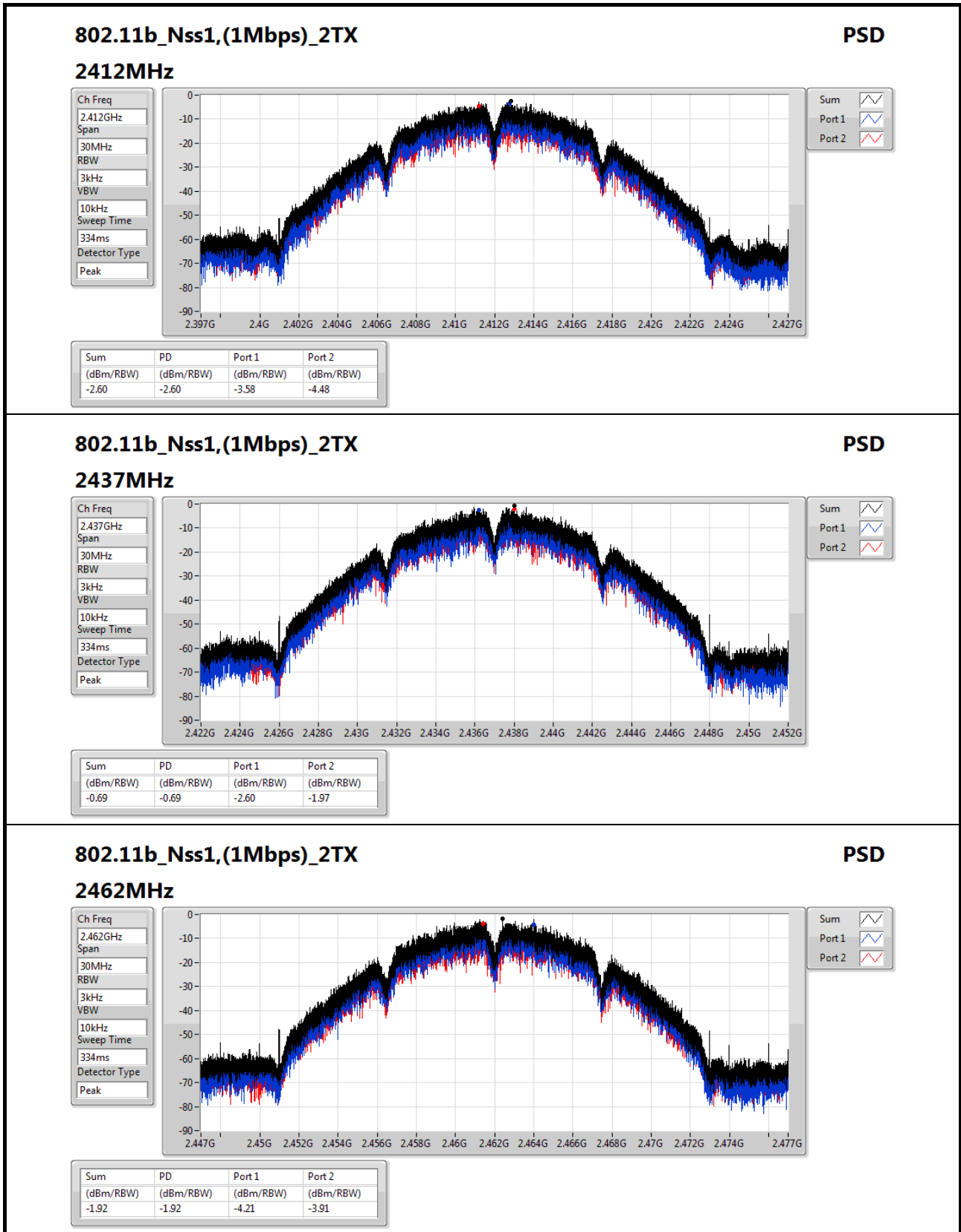

802.11b_Nss1,(1Mbps)_2TX

2462MHz

PSD

Ch Freq
2.462GHz

Span
30MHz

RBW
3kHz

VBW
10kHz

Sweep Time
334ms

Detector Type
Peak

Sum

Port 1

Port 2

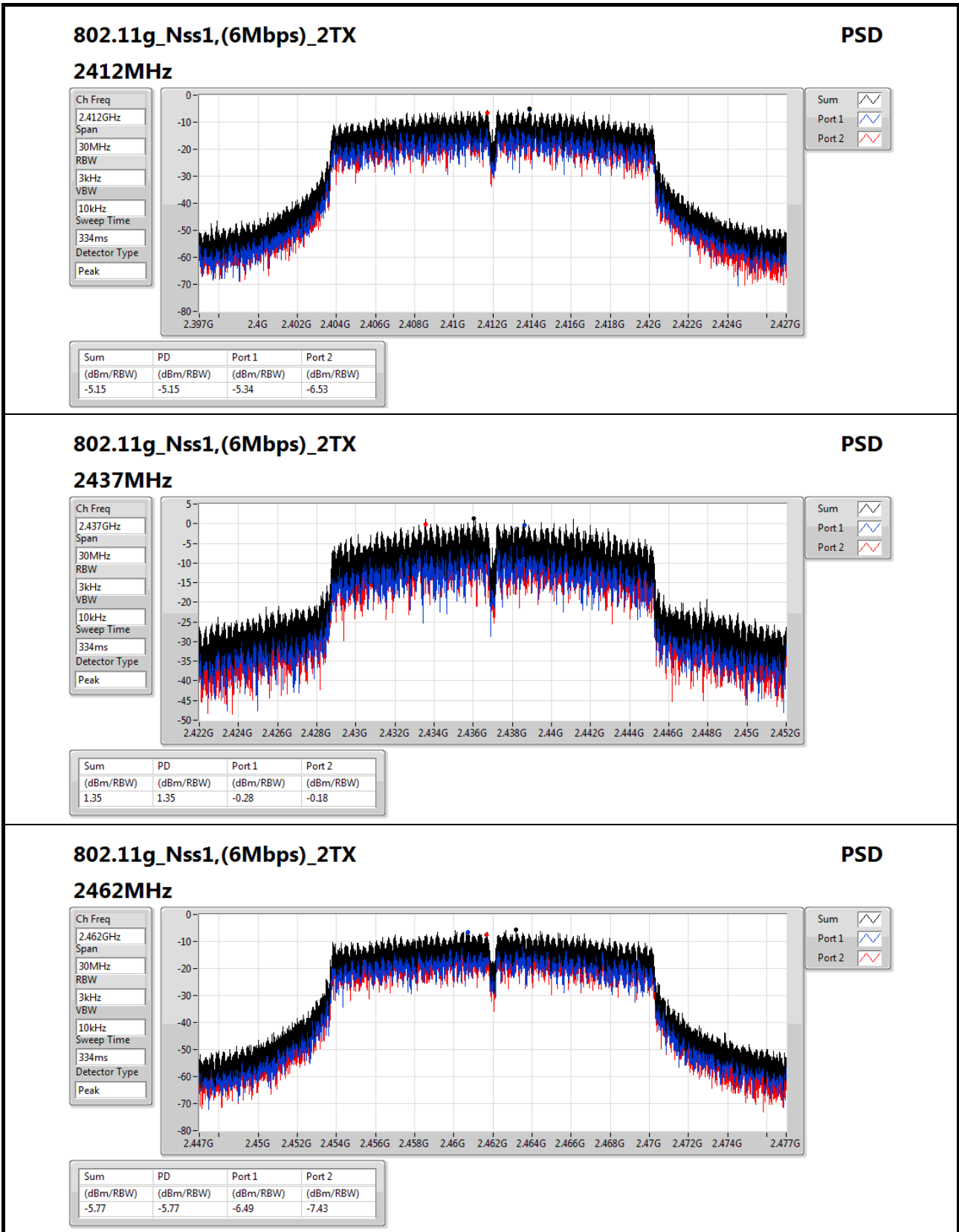
802.11g_Nss1,(6Mbps)_2TX
PSD

2462MHz

Ch Freq
2.462GHz

Span
30MHz

RBW
3kHz

VBW
10kHz

Sweep Time
334ms

Detector Type
Peak

Sum

Port 1

Port 2

| Sum | PD | Port 1 | Port 2 |
|-----------|-----------|-----------|-----------|
| (dBm/RBW) | (dBm/RBW) | (dBm/RBW) | (dBm/RBW) |
| -5.77 | -5.77 | -6.49 | -7.43 |

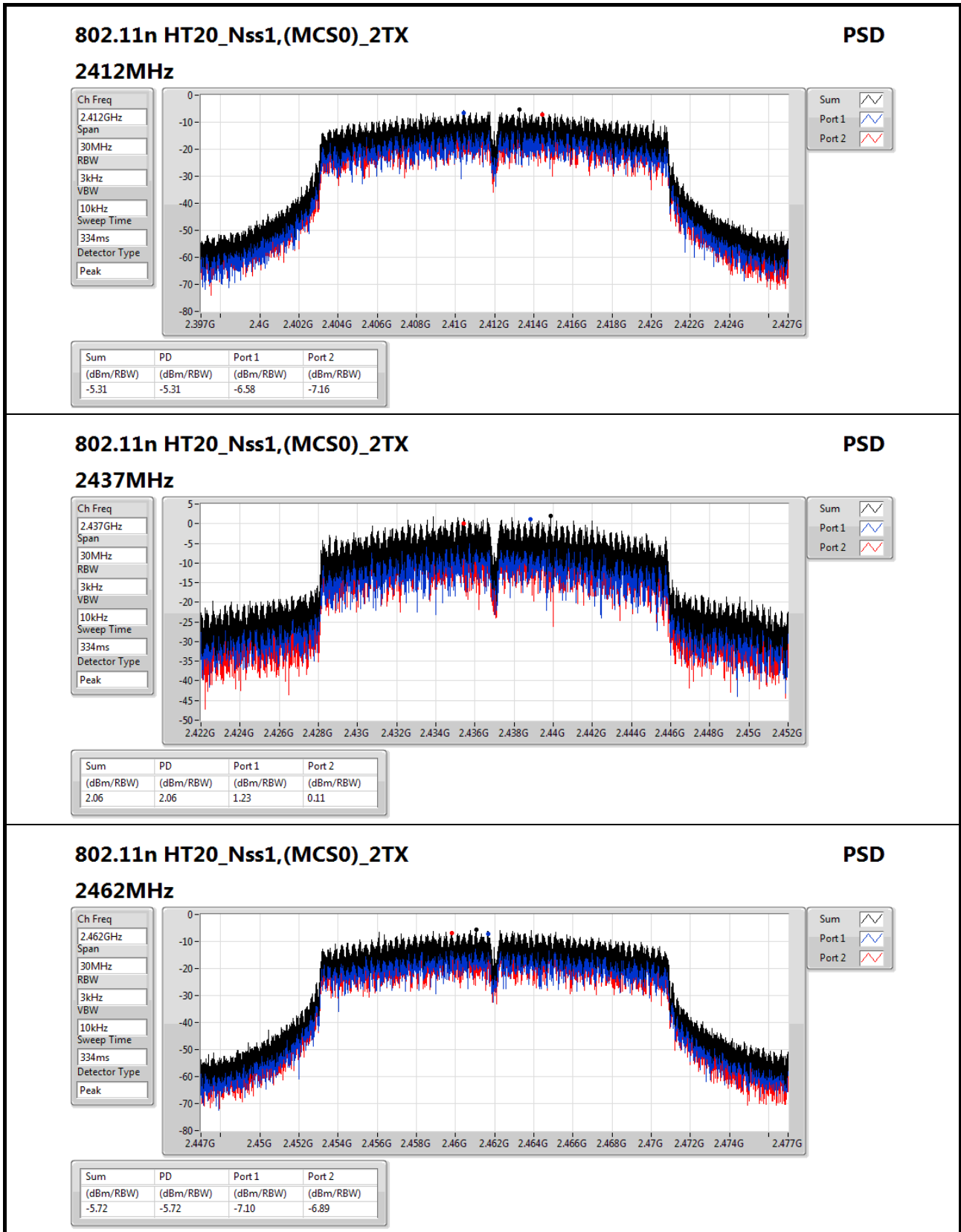
802.11n HT20_Nss1,(MCS0)_2TX
PSD

2462MHz

Ch Freq
2.462GHz

Span
30MHz

RBW
3kHz

VBW
10kHz

Sweep Time
334ms

Detector Type
Peak



Sum

Port 1

Port 2

| Sum | PD | Port 1 | Port 2 |
|-----------|-----------|-----------|-----------|
| (dBm/RBW) | (dBm/RBW) | (dBm/RBW) | (dBm/RBW) |
| -5.72 | -5.72 | -7.10 | -6.89 |

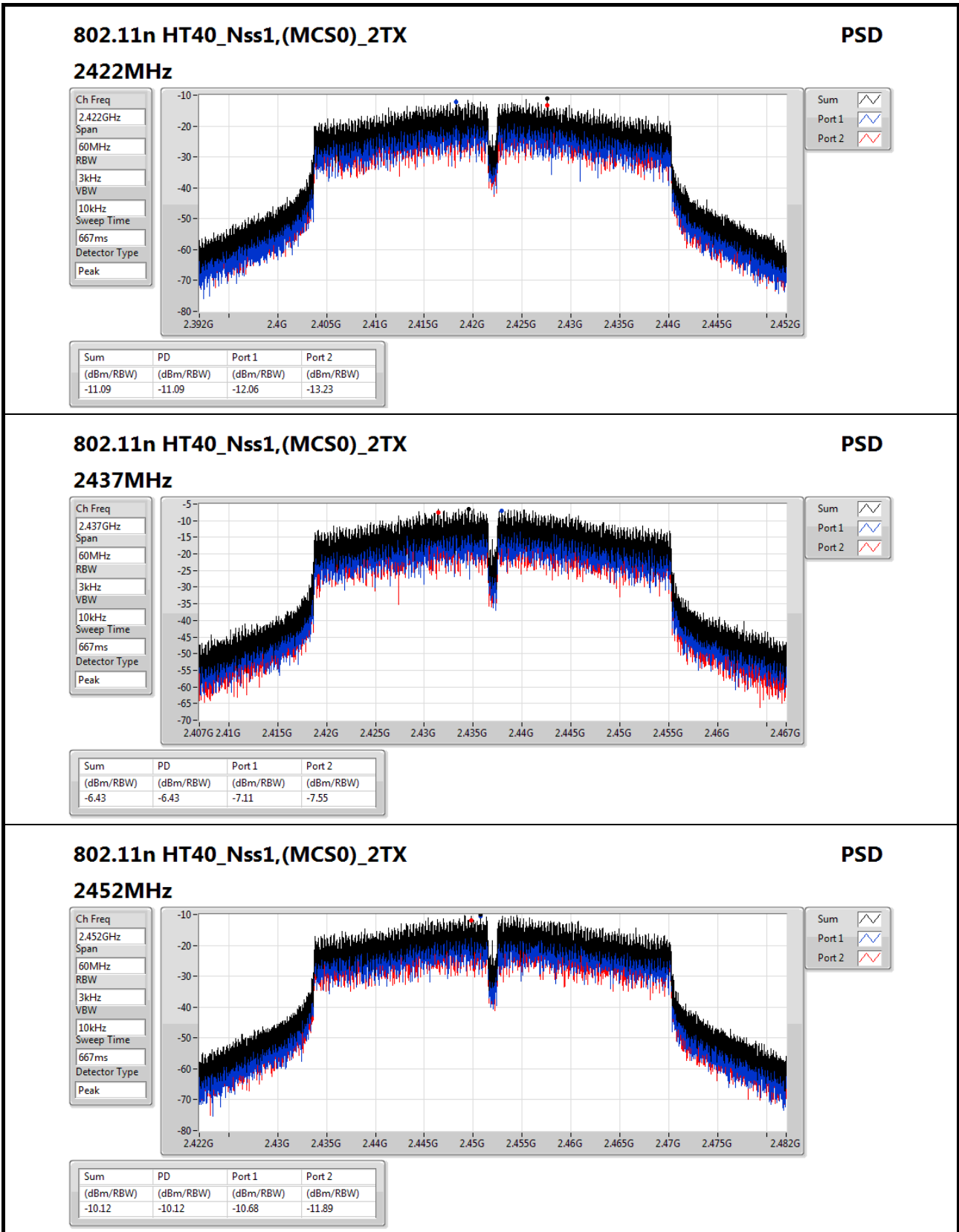

802.11n HT40_Nss1,(MCS0)_2TX

2452MHz

PSD

Ch Freq
2.452GHz

Span
60MHz

RBW
3kHz

VBW
10kHz

Sweep Time
667ms

Detector Type
Peak

Sum

Port 1

Port 2

| Sum | PD | Port 1 | Port 2 |
|-----------|-----------|-----------|-----------|
| (dBm/RBW) | (dBm/RBW) | (dBm/RBW) | (dBm/RBW) |
| -10.12 | -10.12 | -10.68 | -11.89 |



Summary

| Mode | Result | Ref (Hz) | Ref (dBm) | Limit (dBm) | Freq (Hz) | Level (dBm) | Freq (Hz) | Level (dBm) | Freq (Hz) | Level (dBm) | Freq (Hz) | Level (dBm) | Port |
|------------------------------|--------|-----------|-----------|-------------|-----------|-------------|-----------|-------------|-----------|-------------|------------|-------------|------|
| 2.4-2.4835GHz | - | - | - | - | - | - | - | - | - | - | - | - | - |
| 802.11b_Nss1,(1Mbps)_2TX | Pass | 2.437408G | 11.28 | -18.72 | 2.088555G | -52.44 | 2.398G | -42.64 | 2.51438G | -55.70 | 17.608041G | -50.72 | 2 |
| 802.11g_Nss1,(6Mbps)_2TX | Pass | 2.438243G | 12.98 | -17.02 | 2.174765G | -52.81 | 2.39976G | -28.90 | 2.49686G | -51.36 | 3.214652G | -49.32 | 1 |
| 802.11n HT20_Nss1,(MCS0)_2TX | Pass | 2.442084G | 14.93 | -15.07 | 2.09438G | -53.93 | 2.39952G | -32.15 | 2.48398G | -50.39 | 3.214652G | -48.01 | 1 |
| 802.11n HT40_Nss1,(MCS0)_2TX | Pass | 2.431897G | 7.83 | -22.17 | 774.25M | -55.04 | 2.39904G | -32.55 | 2.4851G | -56.33 | 16.765805G | -52.36 | 2 |

Result

| Mode | Result | Ref (Hz) | Ref (dBm) | Limit (dBm) | Freq (Hz) | Level (dBm) | Freq (Hz) | Level (dBm) | Freq (Hz) | Level (dBm) | Freq (Hz) | Level (dBm) | Port |
|------------------------------|--------|-----------|-----------|-------------|-----------|-------------|-----------|-------------|-----------|-------------|------------|-------------|------|
| 802.11b_Nss1,(1Mbps)_2TX | - | - | - | - | - | - | - | - | - | - | - | - | - |
| 2412MHz | Pass | 2.437408G | 11.28 | -18.72 | 2.088555G | -57.75 | 2.39856G | -42.77 | 2.4967G | -55.93 | 16.796078G | -52.85 | 1 |
| 2412MHz | Pass | 2.437408G | 11.28 | -18.72 | 2.088555G | -52.44 | 2.398G | -42.64 | 2.51438G | -55.70 | 17.608041G | -50.72 | 2 |
| 2437MHz | Pass | 2.437408G | 11.28 | -18.72 | 2.30641G | -56.89 | 2.39408G | -50.52 | 2.48926G | -51.72 | 16.815744G | -52.60 | 1 |
| 2437MHz | Pass | 2.437408G | 11.28 | -18.72 | 2.11302G | -48.23 | 2.39872G | -48.57 | 2.48502G | -49.58 | 17.622089G | -52.70 | 2 |
| 2462MHz | Pass | 2.437408G | 11.28 | -18.72 | 1.641195G | -55.76 | 2.392G | -56.53 | 2.48846G | -49.68 | 16.748315G | -52.01 | 1 |
| 2462MHz | Pass | 2.437408G | 11.28 | -18.72 | 2.137485G | -50.36 | 2.39832G | -53.76 | 2.4863G | -49.75 | 16.211689G | -52.63 | 2 |
| 802.11g_Nss1,(6Mbps)_2TX | - | - | - | - | - | - | - | - | - | - | - | - | - |
| 2412MHz | Pass | 2.438243G | 12.98 | -17.02 | 2.174765G | -52.81 | 2.39976G | -28.90 | 2.49686G | -51.36 | 3.214652G | -49.32 | 1 |
| 2412MHz | Pass | 2.438243G | 12.98 | -17.02 | 2.090885G | -52.04 | 2.39992G | -29.34 | 2.49638G | -53.77 | 16.408358G | -52.19 | 2 |
| 2437MHz | Pass | 2.438243G | 12.98 | -17.02 | 1.624885G | -54.76 | 2.39984G | -38.28 | 2.4851G | -44.48 | 3.248367G | -46.90 | 1 |
| 2437MHz | Pass | 2.438243G | 12.98 | -17.02 | 2.193405G | -47.50 | 2.39888G | -39.07 | 2.4847G | -43.54 | 3.248367G | -42.75 | 2 |
| 2462MHz | Pass | 2.438243G | 12.98 | -17.02 | 2.102535G | -53.99 | 2.39344G | -51.66 | 2.48406G | -44.23 | 3.282082G | -51.51 | 1 |
| 2462MHz | Pass | 2.438243G | 12.98 | -17.02 | 2.13865G | -52.65 | 2.3972G | -52.19 | 2.4851G | -44.59 | 3.282082G | -52.17 | 2 |
| 802.11n HT20_Nss1,(MCS0)_2TX | - | - | - | - | - | - | - | - | - | - | - | - | - |
| 2412MHz | Pass | 2.442084G | 14.93 | -15.07 | 2.09438G | -53.93 | 2.39952G | -32.15 | 2.48398G | -50.39 | 3.214652G | -48.01 | 1 |
| 2412MHz | Pass | 2.442084G | 14.93 | -15.07 | 2.17127G | -52.28 | 2.3996G | -33.39 | 2.49614G | -52.66 | 16.20326G | -51.40 | 2 |
| 2437MHz | Pass | 2.442084G | 14.93 | -15.07 | 2.30641G | -54.55 | 2.3992G | -34.88 | 2.48414G | -41.32 | 3.248367G | -47.66 | 1 |
| 2437MHz | Pass | 2.442084G | 14.93 | -15.07 | 2.109525G | -48.89 | 2.39888G | -37.64 | 2.4851G | -42.18 | 3.248367G | -43.10 | 2 |
| 2462MHz | Pass | 2.442084G | 14.93 | -15.07 | 2.300585G | -53.74 | 2.39264G | -51.98 | 2.48358G | -42.88 | 3.282082G | -49.40 | 1 |
| 2462MHz | Pass | 2.442084G | 14.93 | -15.07 | 2.14098G | -51.63 | 2.39216G | -51.72 | 2.48382G | -45.06 | 16.447692G | -51.72 | 2 |
| 802.11n HT40_Nss1,(MCS0)_2TX | - | - | - | - | - | - | - | - | - | - | - | - | - |
| 2422MHz | Pass | 2.431897G | 7.83 | -22.17 | 2.300535G | -57.70 | 2.39792G | -33.40 | 2.4843G | -55.60 | 16.802264G | -52.87 | 1 |
| 2422MHz | Pass | 2.431897G | 7.83 | -22.17 | 774.25M | -55.04 | 2.39904G | -32.55 | 2.4851G | -56.33 | 16.765805G | -52.36 | 2 |
| 2437MHz | Pass | 2.431897G | 7.83 | -22.17 | 2.302825G | -52.83 | 2.39904G | -35.37 | 2.48382G | -42.86 | 3.247813G | -48.58 | 1 |
| 2437MHz | Pass | 2.431897G | 7.83 | -22.17 | 2.10932G | -53.54 | 2.39984G | -39.49 | 2.48734G | -44.92 | 16.903228G | -51.32 | 2 |
| 2452MHz | Pass | 2.431897G | 7.83 | -22.17 | 2.078405G | -59.25 | 2.39392G | -52.84 | 2.48382G | -43.87 | 16.785436G | -51.91 | 1 |
| 2452MHz | Pass | 2.431897G | 7.83 | -22.17 | 2.128785G | -56.05 | 2.3984G | -52.85 | 2.48414G | -45.22 | 16.827505G | -51.97 | 2 |

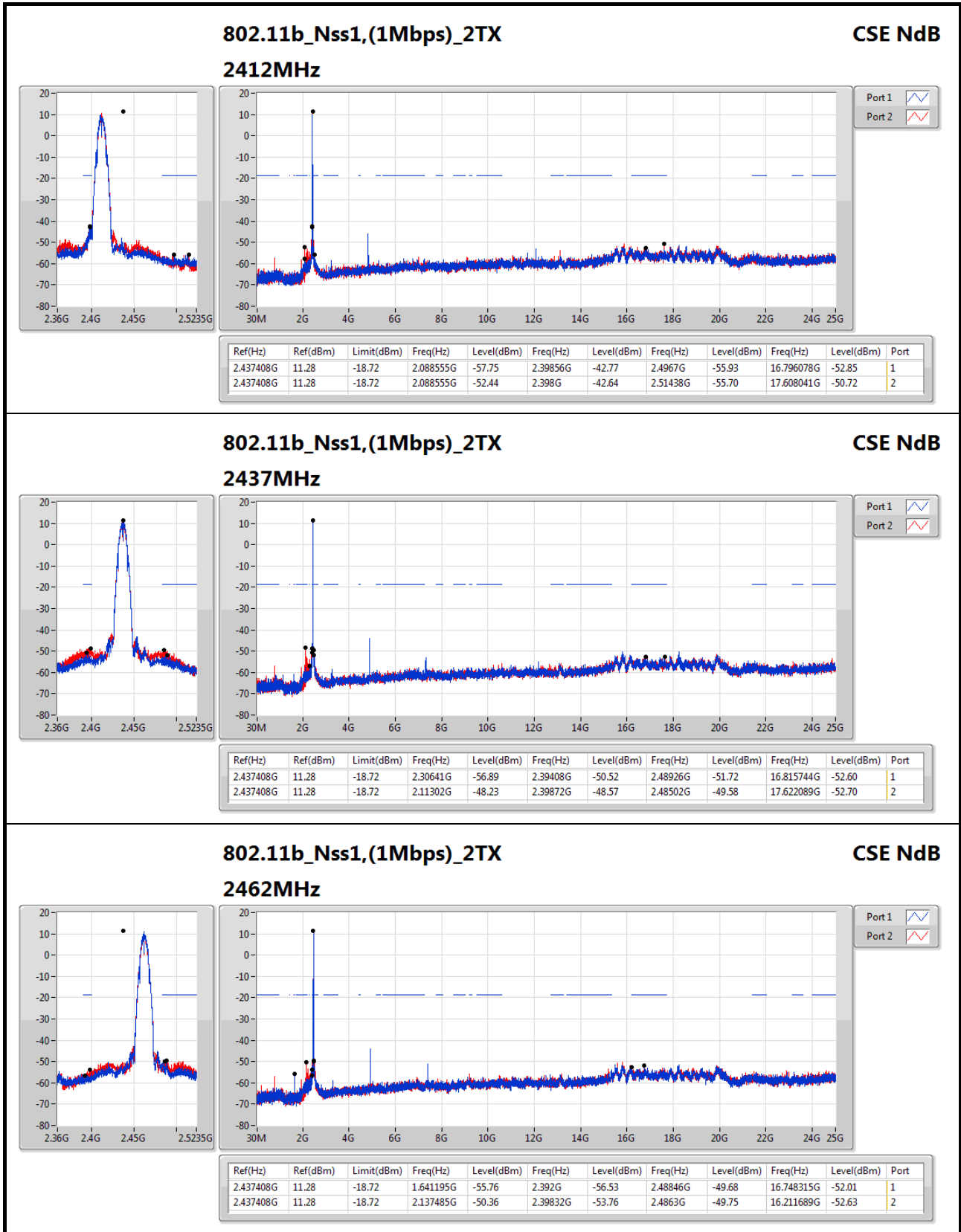

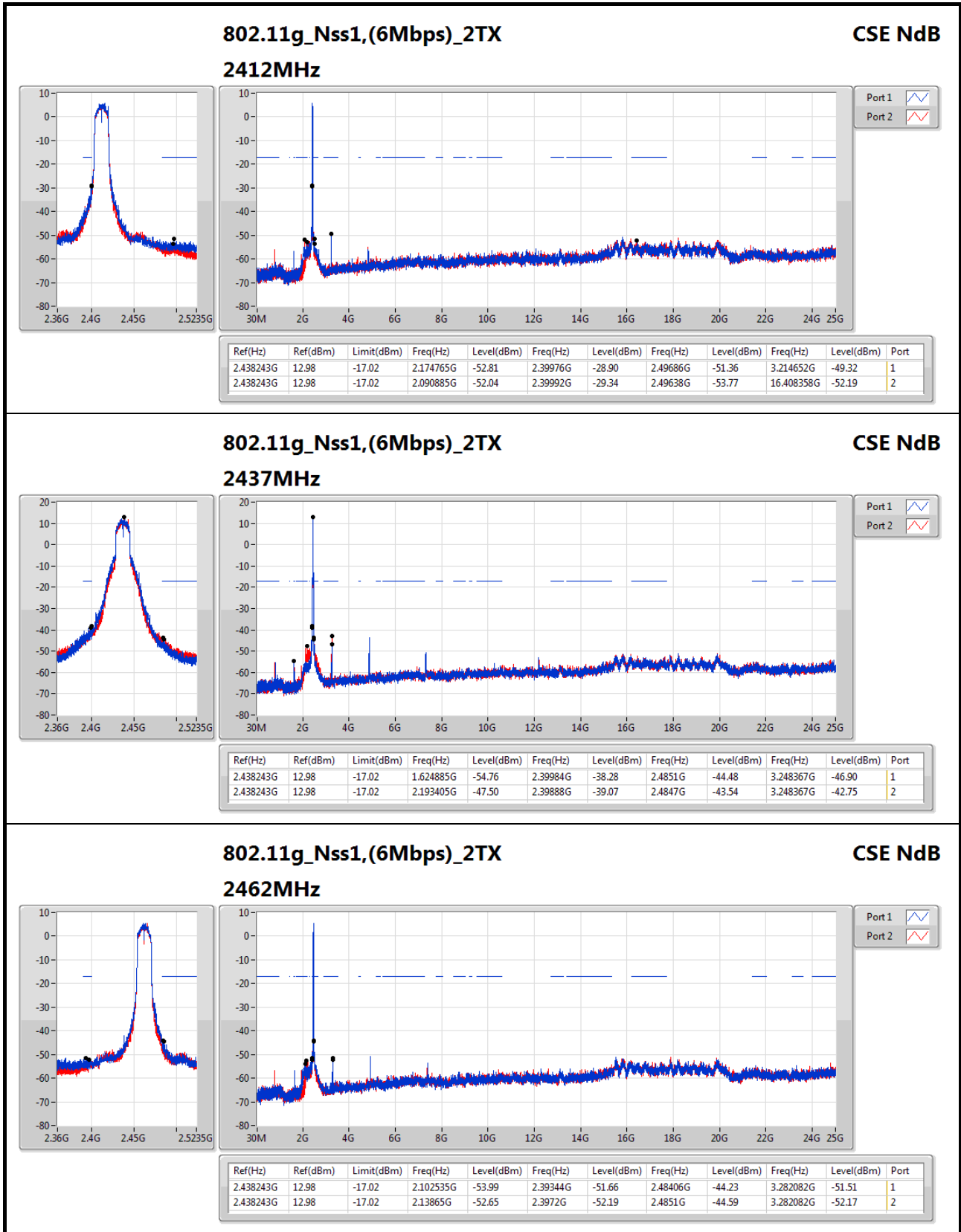

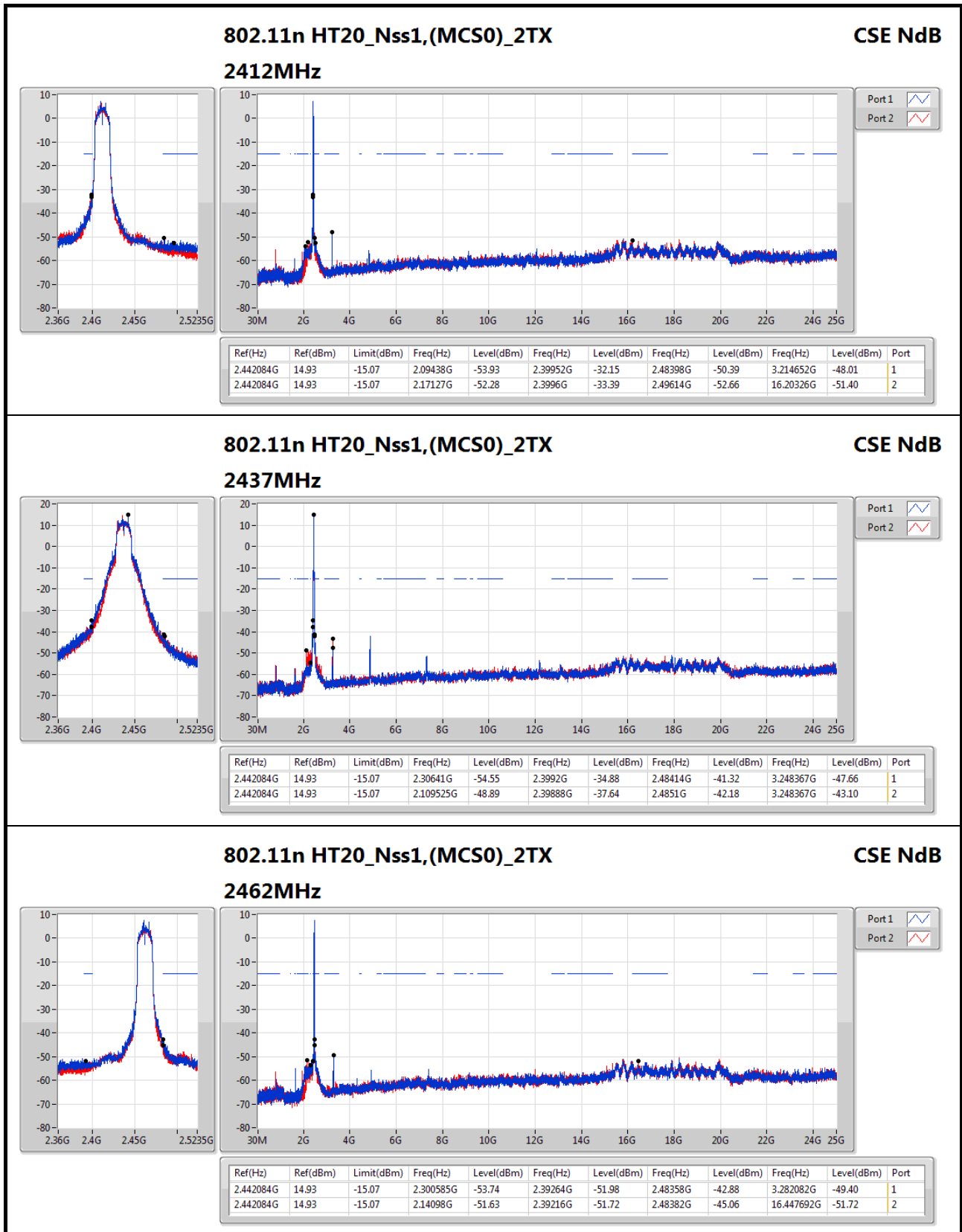

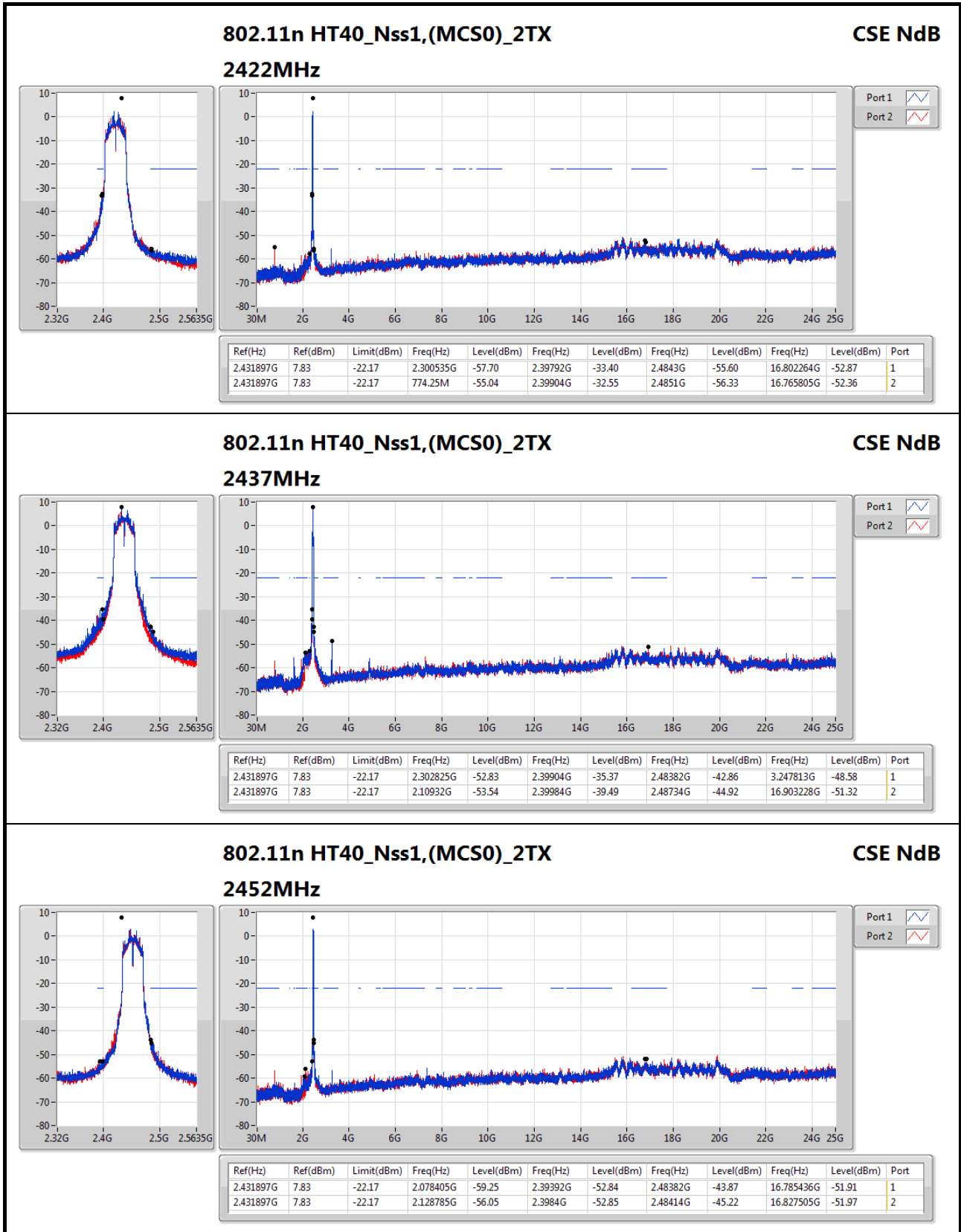



RSE below 1GHz Result

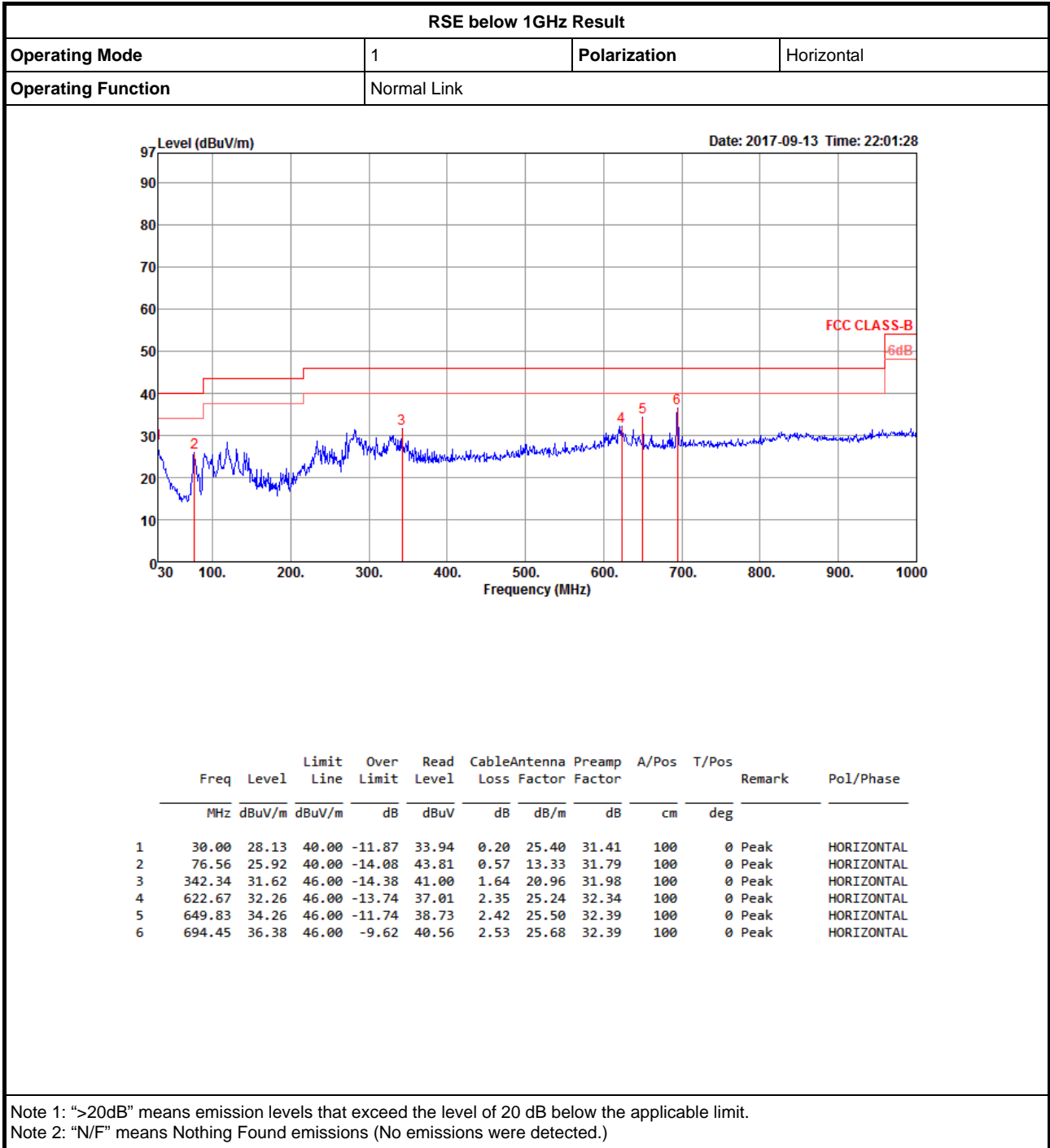



RSE below 1GHz Result

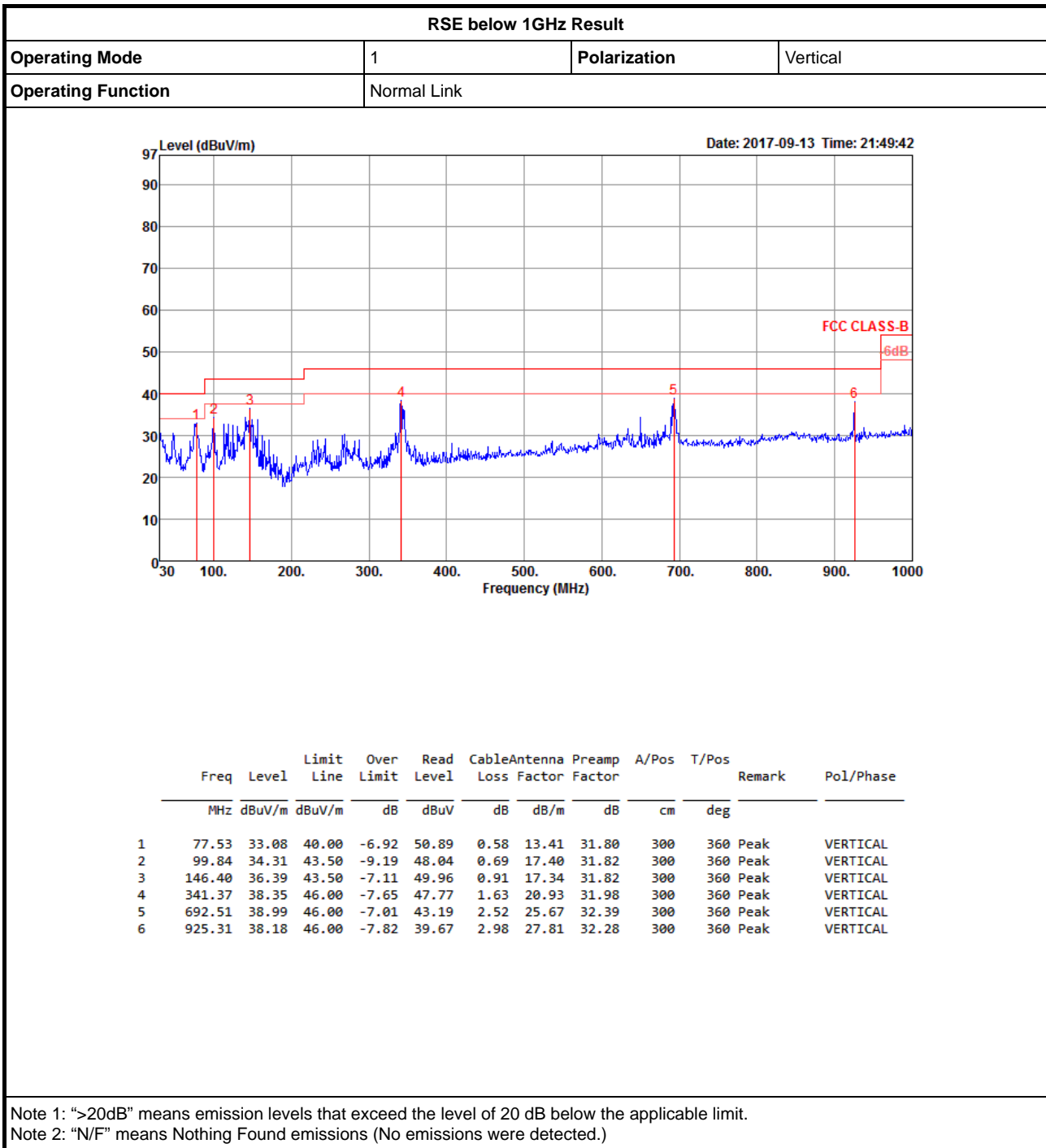



Summary

| Mode | Result | Type | Freq (Hz) | Level (dBuV/m) | Limit (dBuV/m) | Margin (dB) | Factor (dB) | Dist (m) | Condition | Azimuth (°) | Height (m) | Comments |
|--------------------------|--------|------|-----------|----------------|----------------|-------------|-------------|----------|-----------|-------------|------------|----------|
| 2.4-2.4835GHz | - | - | - | - | - | - | - | - | - | - | - | - |
| 802.11b_Nss1,(1Mbps)_2TX | Pass | AV | 4.92398G | 53.98 | 54.00 | -0.02 | 9.16 | 3 | Vertical | 139 | 1.50 | - |

802.11b_Nss1,(1Mbps)_2TX

2412MHz_TX

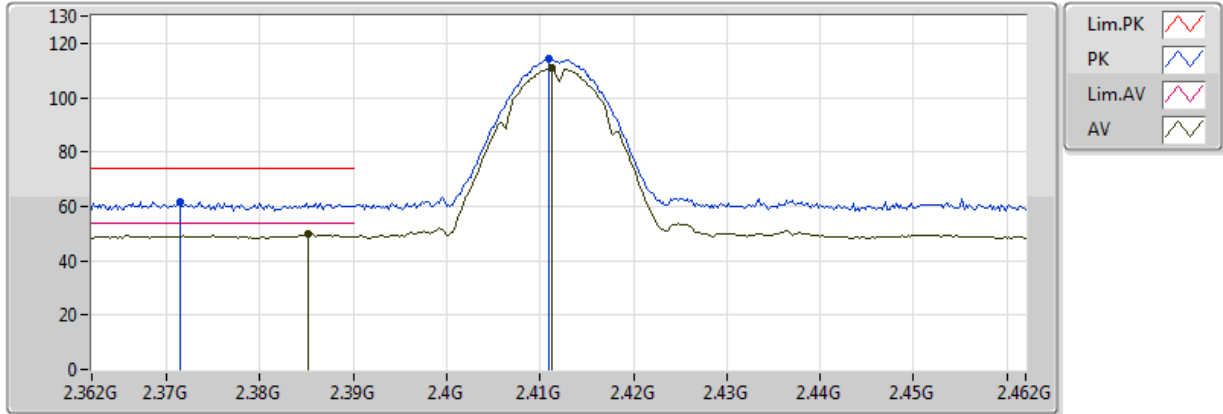

20170919
 EUT Y_2TX ANT Dipole
 Setting 19
 02-Z-1
 FSU

| Type | Freq (Hz) | Level (dBuV/m) | Limit (dBuV/m) | Margin (dB) | Factor (dB) | Dist (m) | Condition | Azimuth (°) | Height (m) |
|------|-----------|----------------|----------------|-------------|-------------|----------|-----------|-------------|------------|
| AV | 2.3852G | 49.83 | 54.00 | -4.17 | 32.11 | 3 | Vertical | 257 | 1.54 |
| AV | 2.4112G | 110.87 | Inf | -Inf | 32.19 | 3 | Vertical | 257 | 1.54 |
| PK | 2.3714G | 61.73 | 74.00 | -12.27 | 32.07 | 3 | Vertical | 257 | 1.54 |
| PK | 2.411G | 114.35 | Inf | -Inf | 32.19 | 3 | Vertical | 257 | 1.54 |



802.11b_Nss1,(1Mbps)_2TX

2412MHz_TX

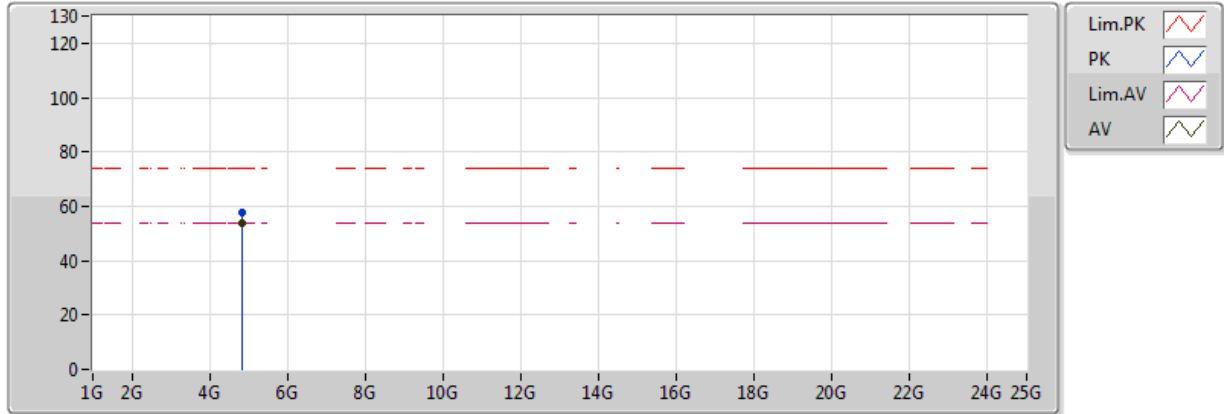

20170919
 EUT Y_2TX ANT Dipole
 Setting 19
 02-Z-1
 FSU

| Type | Freq (Hz) | Level (dBuV/m) | Limit (dBuV/m) | Margin (dB) | Factor (dB) | Dist (m) | Condition | Azimuth (°) | Height (m) |
|------|--------------|-------------------|-------------------|----------------|----------------|-------------|-----------|----------------|---------------|
| AV | 4.82402G | 53.97 | 54.00 | -0.03 | 8.85 | 3 | Vertical | 304 | 2.05 |
| PK | 4.82392G | 57.45 | 74.00 | -16.55 | 8.85 | 3 | Vertical | 304 | 2.05 |



802.11b_Nss1,(1Mbps)_2TX

2412MHz_TX

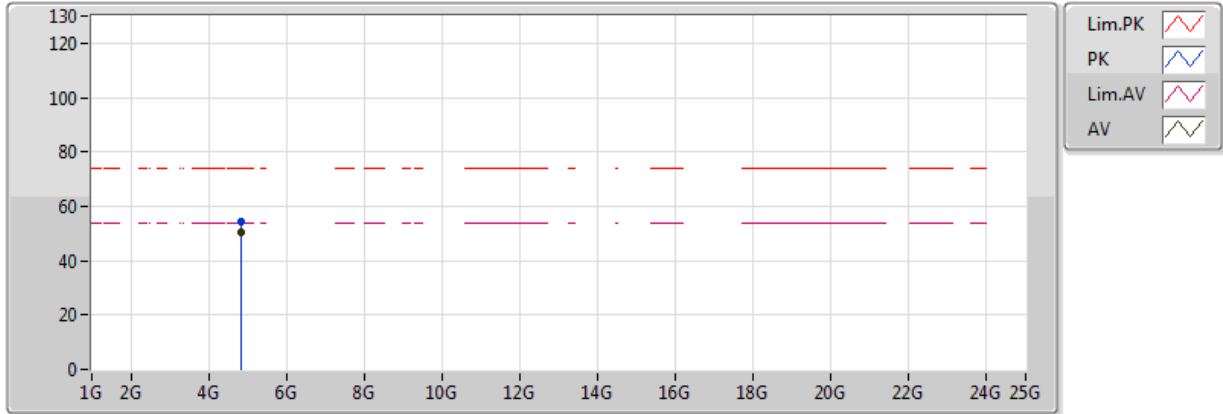

20170919
 EUT Y_2TX ANT Dipole
 Setting 19
 02-Z-1
 FSU

| Type | Freq (Hz) | Level (dBuV/m) | Limit (dBuV/m) | Margin (dB) | Factor (dB) | Dist (m) | Condition | Azimuth (°) | Height (m) |
|------|-----------|----------------|----------------|-------------|-------------|----------|------------|-------------|------------|
| AV | 4.824G | 50.43 | 54.00 | -3.57 | 8.85 | 3 | Horizontal | 160 | 1.50 |
| PK | 4.82394G | 54.28 | 74.00 | -19.72 | 8.85 | 3 | Horizontal | 160 | 1.50 |

802.11b_Nss1,(1Mbps)_2TX

2422MHz_TX

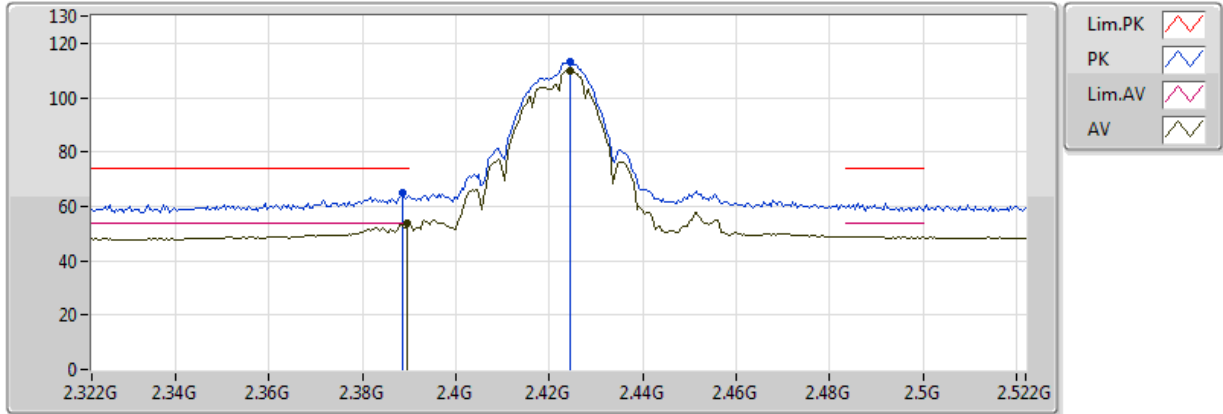

20170925
 EUT Y_2TX Dipole
 Setting 27
 02-D-1
 FSU(100015)

| Type | Freq (Hz) | Level (dBuV/m) | Limit (dBuV/m) | Margin (dB) | Factor (dB) | Dist (m) | Condition | Azimuth (°) | Height (m) |
|------|-----------|----------------|----------------|-------------|-------------|----------|-----------|-------------|------------|
| AV | 2.3896G | 53.66 | 54.00 | -0.34 | 32.13 | 3 | Vertical | 69 | 2.74 |
| AV | 2.4244G | 109.76 | Inf | -Inf | 32.23 | 3 | Vertical | 69 | 2.74 |
| PK | 2.3884G | 65.22 | 74.00 | -8.78 | 32.12 | 3 | Vertical | 69 | 2.74 |
| PK | 2.4244G | 113.35 | Inf | -Inf | 32.23 | 3 | Vertical | 69 | 2.74 |

802.11b_Nss1,(1Mbps)_2TX

2437MHz_TX

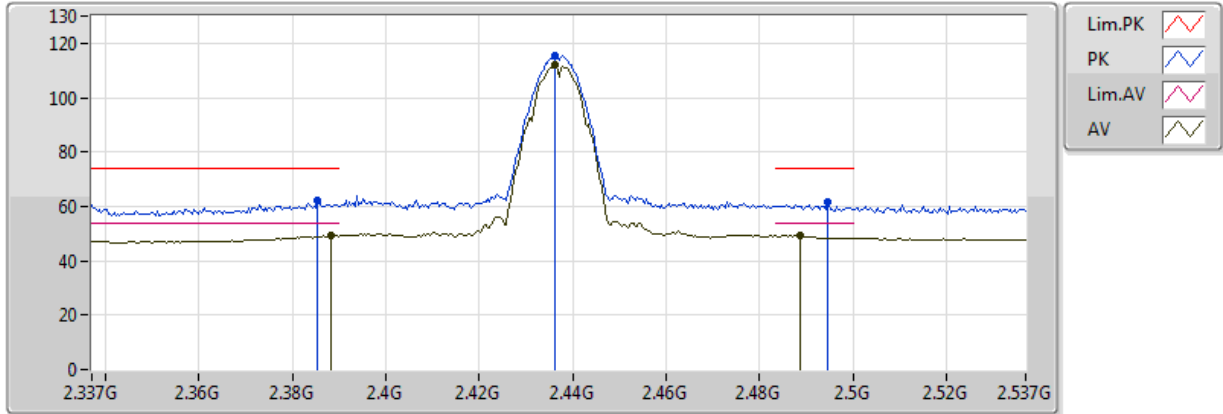

20170919
 EUT Y_2TX ANT Dipole
 Setting 20
 02-Z-1
 FSU

| Type | Freq (Hz) | Level (dBuV/m) | Limit (dBuV/m) | Margin (dB) | Factor (dB) | Dist (m) | Condition | Azimuth (°) | Height (m) |
|------|-----------|----------------|----------------|-------------|-------------|----------|-----------|-------------|------------|
| AV | 2.3882G | 49.51 | 54.00 | -4.49 | 32.12 | 3 | Vertical | 248 | 1.50 |
| AV | 2.4362G | 111.95 | Inf | -Inf | 32.26 | 3 | Vertical | 248 | 1.50 |
| AV | 2.4886G | 49.20 | 54.00 | -4.80 | 32.42 | 3 | Vertical | 248 | 1.50 |
| PK | 2.3854G | 62.14 | 74.00 | -11.86 | 32.11 | 3 | Vertical | 248 | 1.50 |
| PK | 2.4362G | 115.35 | Inf | -Inf | 32.26 | 3 | Vertical | 248 | 1.50 |
| PK | 2.4946G | 61.84 | 74.00 | -12.16 | 32.43 | 3 | Vertical | 248 | 1.50 |



802.11b_Nss1,(1Mbps)_2TX

2437MHz_TX

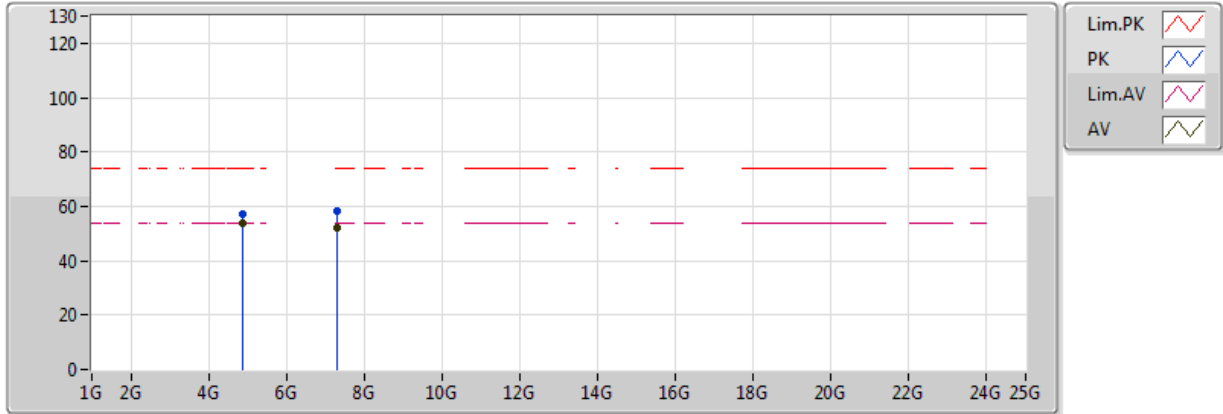

20170919
 EUT Y_2TX ANT Dipole
 Setting 20
 02-Z-1
 FSU

| Type | Freq (Hz) | Level (dBuV/m) | Limit (dBuV/m) | Margin (dB) | Factor (dB) | Dist (m) | Condition | Azimuth (°) | Height (m) |
|------|-----------|----------------|----------------|-------------|-------------|----------|-----------|-------------|------------|
| AV | 4.874G | 53.97 | 54.00 | -0.03 | 9.01 | 3 | Vertical | 151 | 2.56 |
| AV | 7.3102G | 51.95 | 54.00 | -2.05 | 12.90 | 3 | Vertical | 134 | 1.38 |
| PK | 4.874G | 57.25 | 74.00 | -16.75 | 9.01 | 3 | Vertical | 151 | 2.56 |
| PK | 7.31G | 58.39 | 74.00 | -15.61 | 12.90 | 3 | Vertical | 134 | 1.38 |

802.11b_Nss1,(1Mbps)_2TX

2437MHz_TX

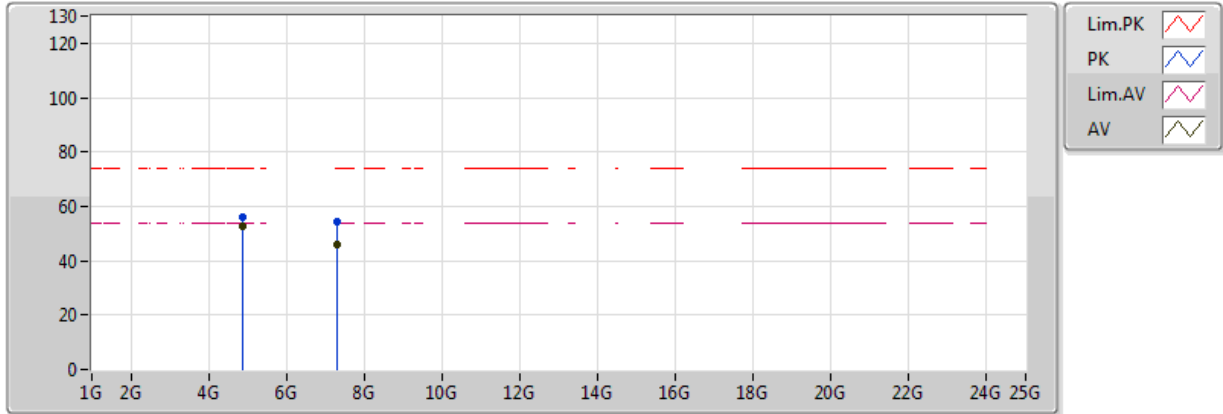

20170919
 EUT Y_2TX ANT Dipole
 Setting 20
 02-Z-1
 FSU

| Type | Freq (Hz) | Level (dBuV/m) | Limit (dBuV/m) | Margin (dB) | Factor (dB) | Dist (m) | Condition | Azimuth (°) | Height (m) |
|------|-----------|----------------|----------------|-------------|-------------|----------|------------|-------------|------------|
| AV | 4.87398G | 52.64 | 54.00 | -1.36 | 9.01 | 3 | Horizontal | 152 | 1.50 |
| AV | 7.30926G | 46.04 | 54.00 | -7.96 | 12.90 | 3 | Horizontal | 280 | 1.25 |
| PK | 4.874G | 56.04 | 74.00 | -17.96 | 9.01 | 3 | Horizontal | 152 | 1.50 |
| PK | 7.30938G | 54.35 | 74.00 | -19.65 | 12.90 | 3 | Horizontal | 280 | 1.25 |

802.11b_Nss1,(1Mbps)_2TX

2452MHz_TX

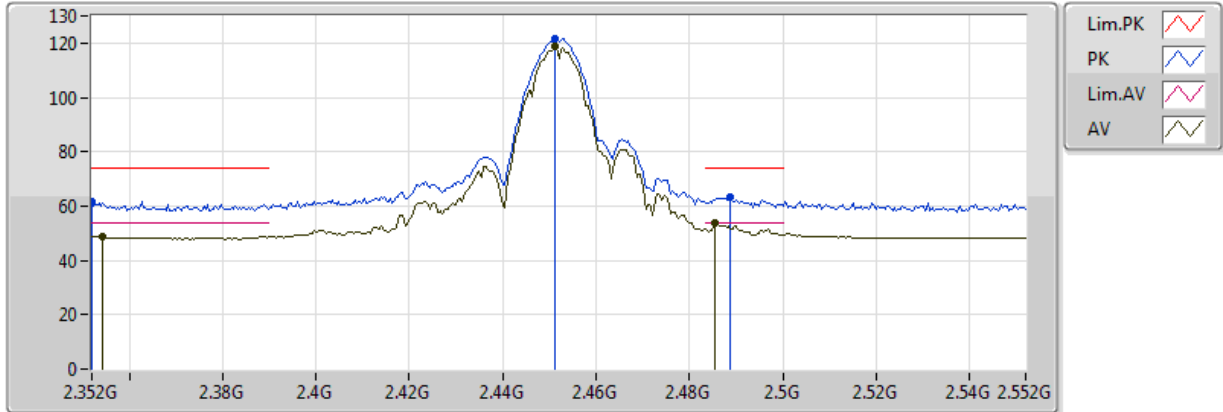

20170925
 EUT Y_2TX Dipole
 Setting 29
 02-D-1
 FSU(100015)

| Type | Freq (Hz) | Level (dBuV/m) | Limit (dBuV/m) | Margin (dB) | Factor (dB) | Dist (m) | Condition | Azimuth (°) | Height (m) |
|------|-----------|----------------|----------------|-------------|-------------|----------|-----------|-------------|------------|
| AV | 2.3544G | 48.74 | 54.00 | -5.26 | 32.02 | 3 | Vertical | 210 | 1.50 |
| AV | 2.4512G | 118.62 | Inf | -Inf | 32.31 | 3 | Vertical | 210 | 1.50 |
| AV | 2.4856G | 53.87 | 54.00 | -0.13 | 32.41 | 3 | Vertical | 210 | 1.50 |
| PK | 2.352G | 61.60 | 74.00 | -12.40 | 32.01 | 3 | Vertical | 210 | 1.50 |
| PK | 2.4512G | 121.87 | Inf | -Inf | 32.31 | 3 | Vertical | 210 | 1.50 |
| PK | 2.4888G | 63.10 | 74.00 | -10.90 | 32.42 | 3 | Vertical | 210 | 1.50 |

802.11b_Nss1,(1Mbps)_2TX

2462MHz_TX

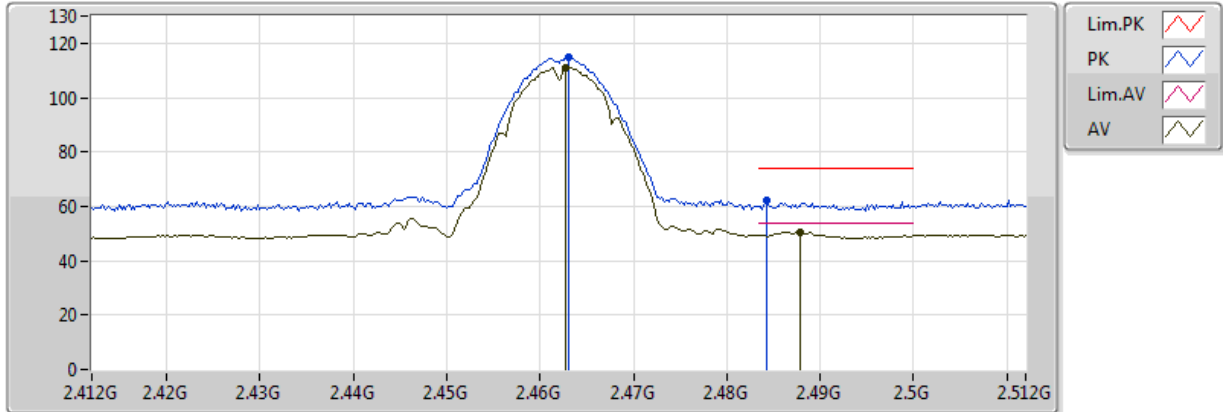

20170919
 EUT_Y_2TX ANT Dipole
 Setting 19.5
 02-Z-1
 FSU

| Type | Freq (Hz) | Level (dBuV/m) | Limit (dBuV/m) | Margin (dB) | Factor (dB) | Dist (m) | Condition | Azimuth (°) | Height (m) |
|------|-----------|----------------|----------------|-------------|-------------|----------|-----------|-------------|------------|
| AV | 2.4628G | 111.10 | Inf | -Inf | 32.34 | 3 | Vertical | 259 | 2.43 |
| AV | 2.4878G | 50.62 | 54.00 | -3.38 | 32.41 | 3 | Vertical | 259 | 2.43 |
| PK | 2.463G | 115.04 | Inf | -Inf | 32.34 | 3 | Vertical | 259 | 2.43 |
| PK | 2.4842G | 62.09 | 74.00 | -11.91 | 32.40 | 3 | Vertical | 259 | 2.43 |



802.11b_Nss1,(1Mbps)_2TX

2462MHz_TX

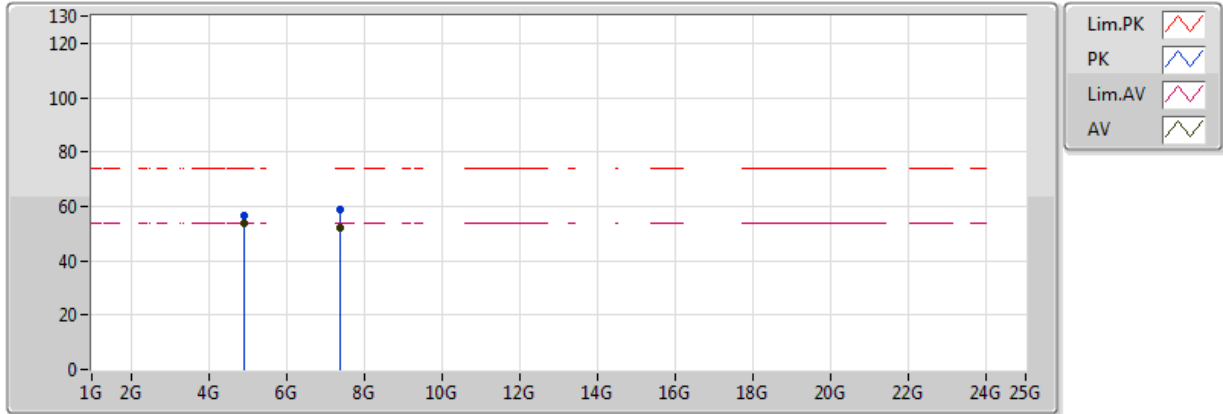

20170919
 EUT Y_2TX ANT Dipole
 Setting 19.5
 02-Z-1
 FSU

| Type | Freq (Hz) | Level (dBuV/m) | Limit (dBuV/m) | Margin (dB) | Factor (dB) | Dist (m) | Condition | Azimuth (°) | Height (m) |
|------|-----------|----------------|----------------|-------------|-------------|----------|-----------|-------------|------------|
| AV | 4.92398G | 53.98 | 54.00 | -0.02 | 9.16 | 3 | Vertical | 139 | 1.50 |
| AV | 7.38528G | 52.03 | 54.00 | -1.97 | 13.07 | 3 | Vertical | 282 | 2.39 |
| PK | 4.92386G | 56.84 | 74.00 | -17.16 | 9.16 | 3 | Vertical | 139 | 1.50 |
| PK | 7.38676G | 58.60 | 74.00 | -15.40 | 13.07 | 3 | Vertical | 282 | 2.39 |



802.11b_Nss1,(1Mbps)_2TX

2462MHz_TX

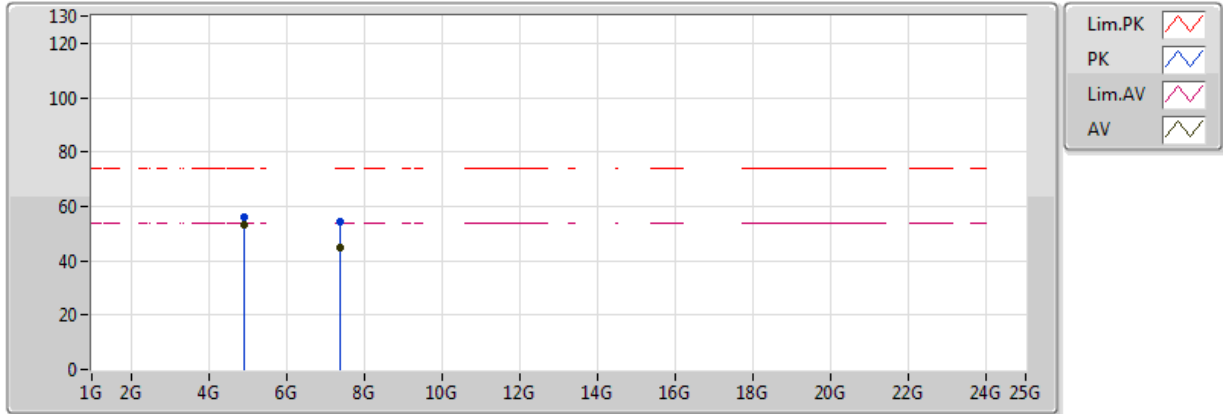

20170919
 EUT Y_2TX ANT Dipole
 Setting 19.5
 02-Z-1
 FSU

| Type | Freq (Hz) | Level (dBuV/m) | Limit (dBuV/m) | Margin (dB) | Factor (dB) | Dist (m) | Condition | Azimuth (°) | Height (m) |
|------|-----------|----------------|----------------|-------------|-------------|----------|------------|-------------|------------|
| AV | 4.92398G | 53.47 | 54.00 | -0.53 | 9.16 | 3 | Horizontal | 134 | 1.27 |
| AV | 7.38428G | 44.70 | 54.00 | -9.30 | 13.07 | 3 | Horizontal | 123 | 1.30 |
| PK | 4.92396G | 56.11 | 74.00 | -17.89 | 9.16 | 3 | Horizontal | 134 | 1.27 |
| PK | 7.3845G | 54.12 | 74.00 | -19.88 | 13.07 | 3 | Horizontal | 123 | 1.30 |

802.11g_Nss1,(6Mbps)_2TX

2412MHz_TX

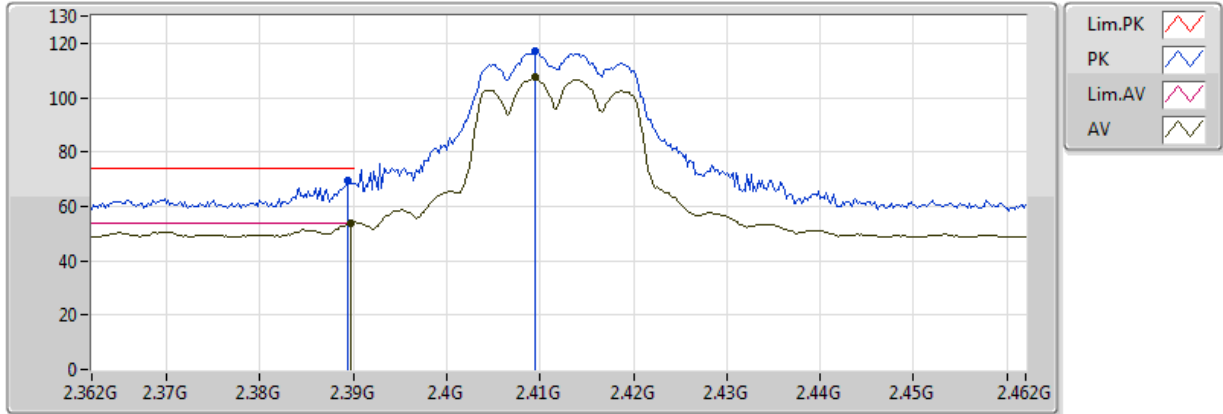

20170919
 EUT Y_2TX ANT Dipole
 Setting 19
 02-Z-1
 FSU

| Type | Freq (Hz) | Level (dBuV/m) | Limit (dBuV/m) | Margin (dB) | Factor (dB) | Dist (m) | Condition | Azimuth (°) | Height (m) |
|------|-----------|----------------|----------------|-------------|-------------|----------|-----------|-------------|------------|
| AV | 2.3898G | 53.96 | 54.00 | -0.04 | 32.13 | 3 | Vertical | 165 | 2.33 |
| AV | 2.4094G | 107.37 | Inf | -Inf | 32.19 | 3 | Vertical | 165 | 2.33 |
| PK | 2.3894G | 69.23 | 74.00 | -4.77 | 32.13 | 3 | Vertical | 165 | 2.33 |
| PK | 2.4094G | 117.09 | Inf | -Inf | 32.19 | 3 | Vertical | 165 | 2.33 |



802.11g_Nss1,(6Mbps)_2TX

2412MHz_TX

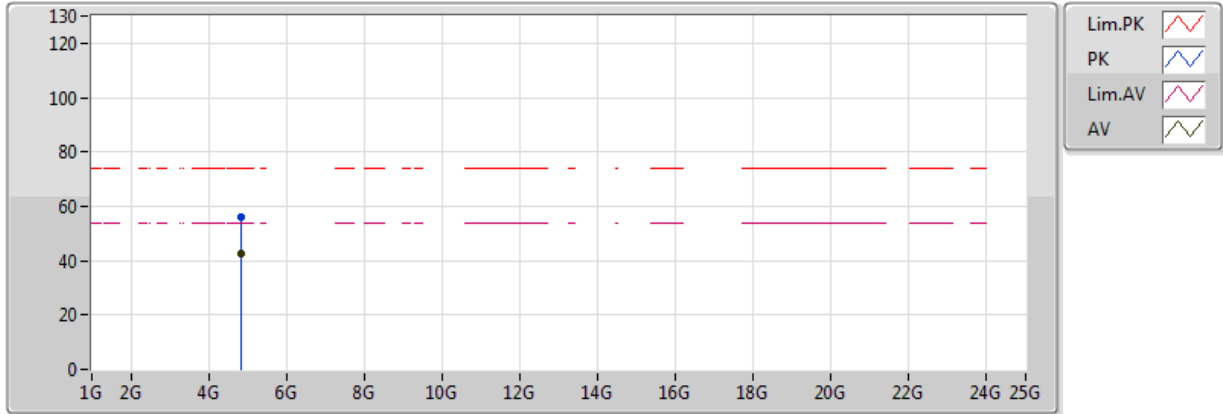

20170919
 EUT Y_2TX ANT Dipole
 Setting 19
 02-Z-1
 FSU

| Type | Freq (Hz) | Level (dBuV/m) | Limit (dBuV/m) | Margin (dB) | Factor (dB) | Dist (m) | Condition | Azimuth (°) | Height (m) |
|------|-----------|----------------|----------------|-------------|-------------|----------|-----------|-------------|------------|
| AV | 4.82504G | 42.42 | 54.00 | -11.58 | 8.86 | 3 | Vertical | 127 | 1.94 |
| PK | 4.81996G | 56.15 | 74.00 | -17.85 | 8.84 | 3 | Vertical | 127 | 1.94 |



802.11g_Nss1,(6Mbps)_2TX

2412MHz_TX

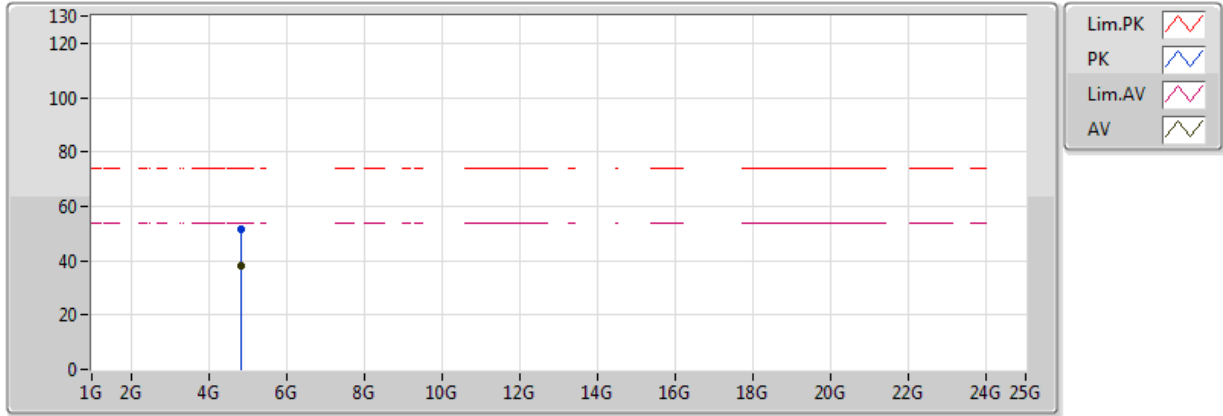

20170919
 EUT Y_2TX ANT Dipole
 Setting 19
 02-Z-1
 FSU

| Type | Freq (Hz) | Level (dBuV/m) | Limit (dBuV/m) | Margin (dB) | Factor (dB) | Dist (m) | Condition | Azimuth (°) | Height (m) |
|------|-----------|----------------|----------------|-------------|-------------|----------|------------|-------------|------------|
| AV | 4.8248G | 38.11 | 54.00 | -15.89 | 8.86 | 3 | Horizontal | 123 | 1.45 |
| PK | 4.82444G | 51.33 | 74.00 | -22.67 | 8.86 | 3 | Horizontal | 123 | 1.45 |

802.11g_Nss1,(6Mbps)_2TX

2422MHz_TX

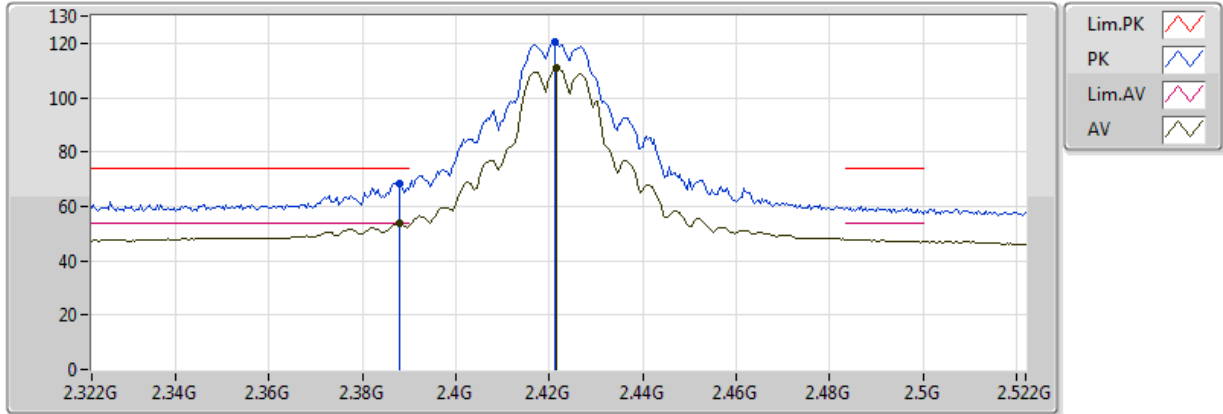

20170922
 EUT Y_2TX ANT Dipole
 Setting 23
 03-P-2
 FSP(100019)

| Type | Freq (Hz) | Level (dBuV/m) | Limit (dBuV/m) | Margin (dB) | Factor (dB) | Dist (m) | Condition | Azimuth (°) | Height (m) |
|------|-----------|----------------|----------------|-------------|-------------|----------|-----------|-------------|------------|
| AV | 2.388G | 53.53 | 54.00 | -0.47 | 31.91 | 3 | Vertical | 249 | 2.02 |
| AV | 2.4216G | 111.01 | Inf | -Inf | 31.99 | 3 | Vertical | 249 | 2.02 |
| PK | 2.388G | 68.60 | 74.00 | -5.40 | 31.91 | 3 | Vertical | 249 | 2.02 |
| PK | 2.4212G | 120.73 | Inf | -Inf | 31.99 | 3 | Vertical | 249 | 2.02 |

802.11g_Nss1,(6Mbps)_2TX

2437MHz_TX

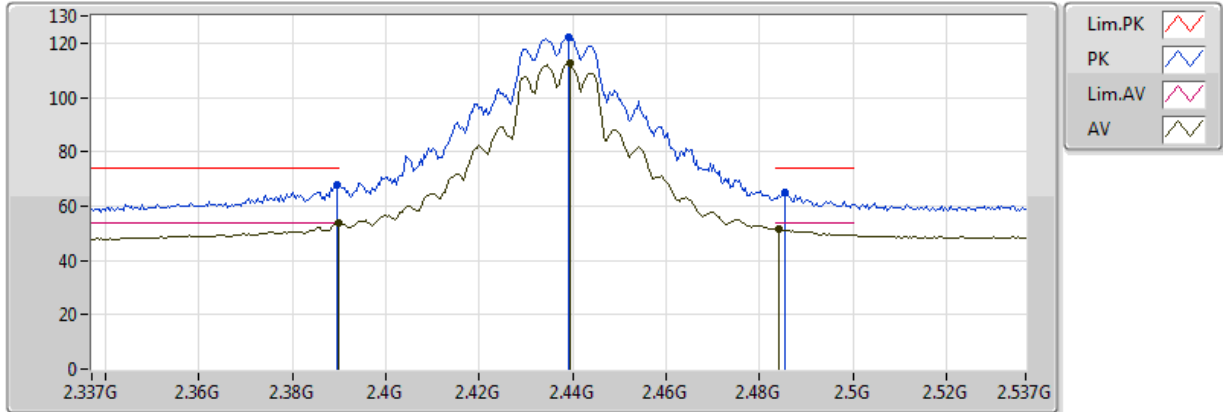

20170919
 EUT Y_2TX ANT Dipole
 Setting 27
 02-Z-1
 FSU

| Type | Freq (Hz) | Level (dBuV/m) | Limit (dBuV/m) | Margin (dB) | Factor (dB) | Dist (m) | Condition | Azimuth (°) | Height (m) |
|------|-----------|----------------|----------------|-------------|-------------|----------|-----------|-------------|------------|
| AV | 2.389998G | 53.68 | 54.00 | -0.32 | 32.13 | 3 | Vertical | 315 | 2.48 |
| AV | 2.4394G | 112.74 | Inf | -Inf | 32.27 | 3 | Vertical | 315 | 2.48 |
| AV | 2.4842G | 51.41 | 54.00 | -2.59 | 32.40 | 3 | Vertical | 315 | 2.48 |
| PK | 2.3894G | 67.88 | 74.00 | -6.12 | 32.13 | 3 | Vertical | 315 | 2.48 |
| PK | 2.439G | 122.17 | Inf | -Inf | 32.27 | 3 | Vertical | 315 | 2.48 |
| PK | 2.4854G | 65.06 | 74.00 | -8.94 | 32.41 | 3 | Vertical | 315 | 2.48 |

802.11g_Nss1,(6Mbps)_2TX

2437MHz_TX

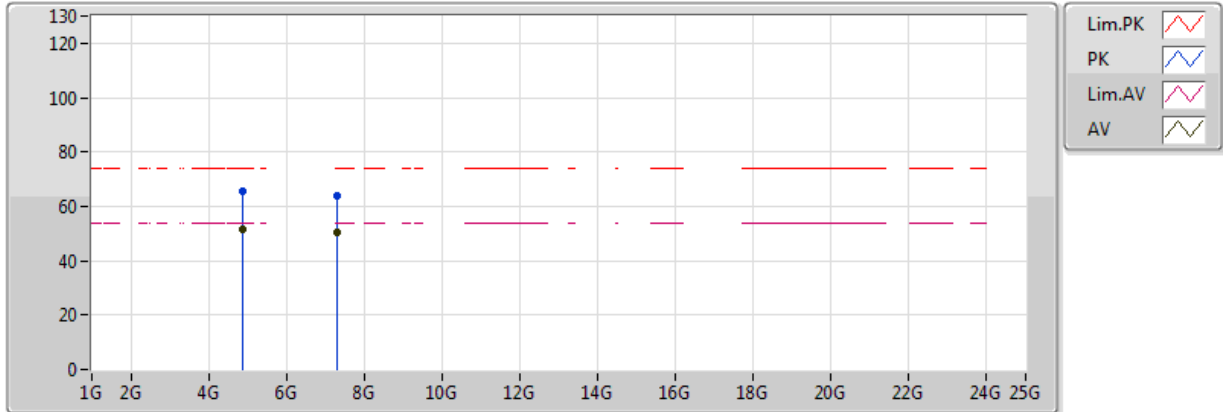

20170919
 EUT_Y_2TX ANT Dipole
 Setting 27
 02-Z-1
 FSU

| Type | Freq (Hz) | Level (dBuV/m) | Limit (dBuV/m) | Margin (dB) | Factor (dB) | Dist (m) | Condition | Azimuth (°) | Height (m) |
|------|-----------|----------------|----------------|-------------|-------------|----------|-----------|-------------|------------|
| AV | 4.8748G | 51.64 | 54.00 | -2.36 | 9.01 | 3 | Vertical | 273 | 1.02 |
| AV | 7.31512G | 50.58 | 54.00 | -3.42 | 12.91 | 3 | Vertical | 268 | 2.42 |
| PK | 4.87528G | 65.63 | 74.00 | -8.37 | 9.01 | 3 | Vertical | 273 | 1.02 |
| PK | 7.31528G | 64.12 | 74.00 | -9.88 | 12.91 | 3 | Vertical | 268 | 2.42 |



802.11g_Nss1,(6Mbps)_2TX

2437MHz_TX

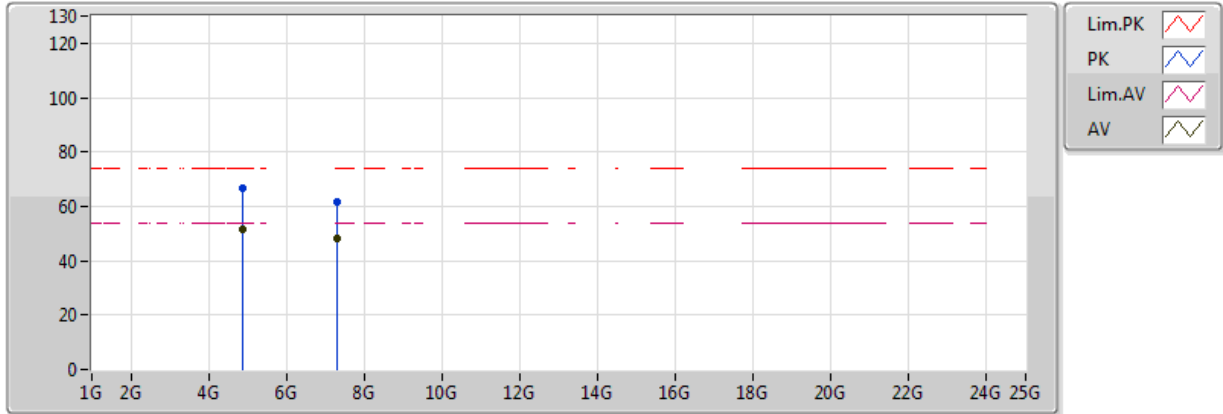

20170919
 EUT Y_2TX ANT Dipole
 Setting 27
 02-Z-1
 FSU

| Type | Freq (Hz) | Level (dBuV/m) | Limit (dBuV/m) | Margin (dB) | Factor (dB) | Dist (m) | Condition | Azimuth (°) | Height (m) |
|------|-----------|----------------|----------------|-------------|-------------|----------|------------|-------------|------------|
| AV | 4.87408G | 51.32 | 54.00 | -2.68 | 9.01 | 3 | Horizontal | 266 | 1.50 |
| AV | 7.3138G | 48.25 | 54.00 | -5.75 | 12.91 | 3 | Horizontal | 131 | 1.30 |
| PK | 4.86984G | 66.88 | 74.00 | -7.12 | 9.00 | 3 | Horizontal | 266 | 1.50 |
| PK | 7.31488G | 61.46 | 74.00 | -12.54 | 12.91 | 3 | Horizontal | 131 | 1.30 |

802.11g_Nss1,(6Mbps)_2TX

2452MHz_TX

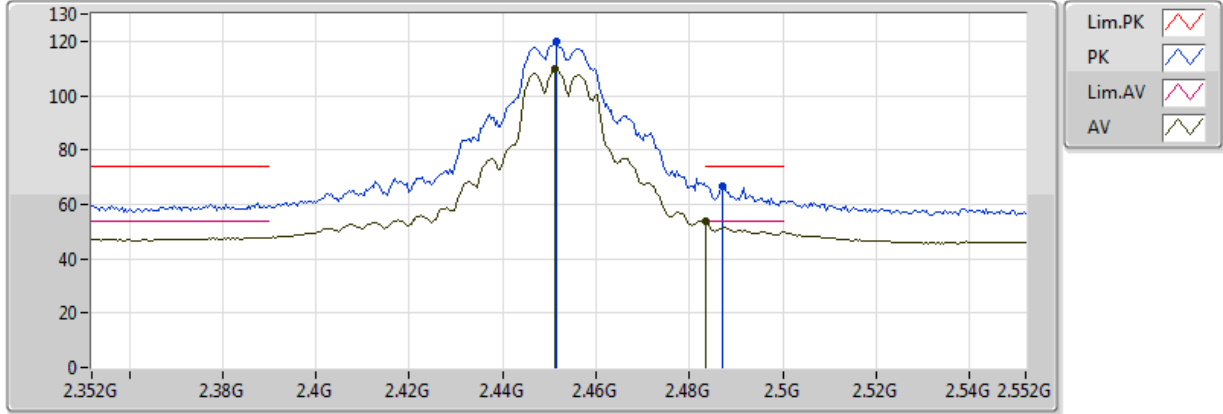

20170922
 EUT_Y_2TX ANT Dipole
 Setting 23
 03-P-2
 FSP(100019)

| Type | Freq (Hz) | Level (dBuV/m) | Limit (dBuV/m) | Margin (dB) | Factor (dB) | Dist (m) | Condition | Azimuth (°) | Height (m) |
|------|-----------|----------------|----------------|-------------|-------------|----------|-----------|-------------|------------|
| AV | 2.4512G | 109.78 | Inf | -Inf | 32.06 | 3 | Vertical | 257 | 1.73 |
| AV | 2.4836G | 53.56 | 54.00 | -0.44 | 32.14 | 3 | Vertical | 257 | 1.73 |
| PK | 2.4516G | 119.65 | Inf | -Inf | 32.06 | 3 | Vertical | 257 | 1.73 |
| PK | 2.4872G | 66.59 | 74.00 | -7.41 | 32.15 | 3 | Vertical | 257 | 1.73 |

802.11g_Nss1,(6Mbps)_2TX

2462MHz_TX

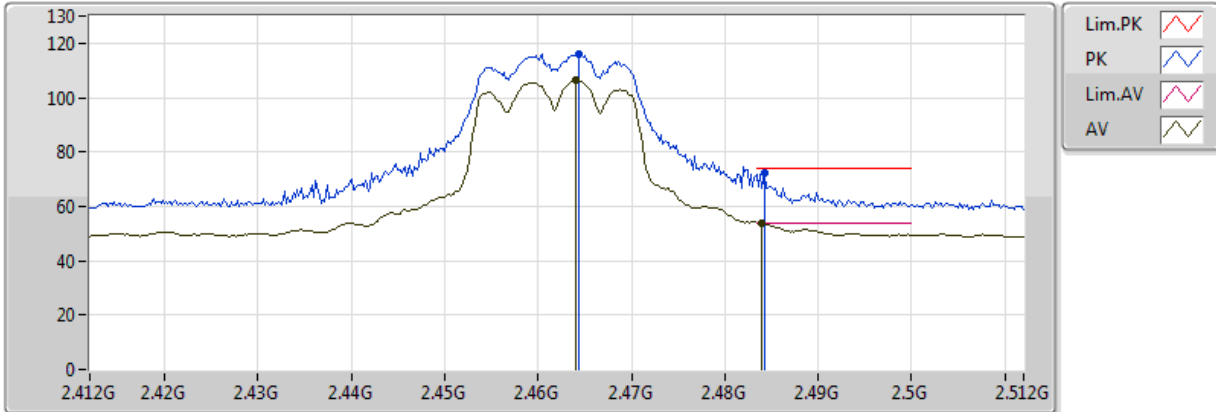

20170919
 EUT_Y_2TX ANT Dipole
 Setting 19
 02-J-6
 FSU

| Type | Freq (Hz) | Level (dBuV/m) | Limit (dBuV/m) | Margin (dB) | Factor (dB) | Dist (m) | Condition | Azimuth (°) | Height (m) |
|------|-----------|----------------|----------------|-------------|-------------|----------|-----------|-------------|------------|
| AV | 2.464G | 106.52 | Inf | -Inf | 32.35 | 3 | Vertical | 168 | 2.06 |
| AV | 2.484G | 53.91 | 54.00 | -0.09 | 32.40 | 3 | Vertical | 168 | 2.06 |
| PK | 2.4644G | 115.92 | Inf | -Inf | 32.35 | 3 | Vertical | 168 | 2.06 |
| PK | 2.4842G | 72.11 | 74.00 | -1.89 | 32.40 | 3 | Vertical | 168 | 2.06 |



802.11g_Nss1,(6Mbps)_2TX

2462MHz_TX

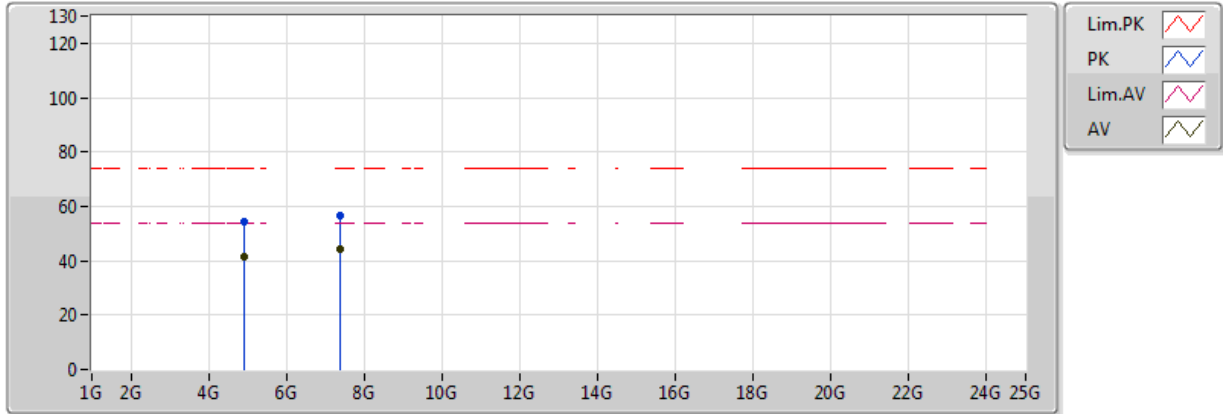

20170919
 EUT Y_2TX ANT Dipole
 Setting 19
 02-J-6
 FSU

| Type | Freq (Hz) | Level (dBuV/m) | Limit (dBuV/m) | Margin (dB) | Factor (dB) | Dist (m) | Condition | Azimuth (°) | Height (m) |
|------|-----------|----------------|----------------|-------------|-------------|----------|-----------|-------------|------------|
| AV | 4.92532G | 41.26 | 54.00 | -12.74 | 9.17 | 3 | Vertical | 134 | 1.12 |
| AV | 7.38582G | 44.07 | 54.00 | -9.93 | 13.07 | 3 | Vertical | 281 | 2.36 |
| PK | 4.92544G | 54.55 | 74.00 | -19.45 | 9.17 | 3 | Vertical | 134 | 1.12 |
| PK | 7.38546G | 56.74 | 74.00 | -17.26 | 13.07 | 3 | Vertical | 281 | 2.36 |

802.11g_Nss1,(6Mbps)_2TX

2462MHz_TX

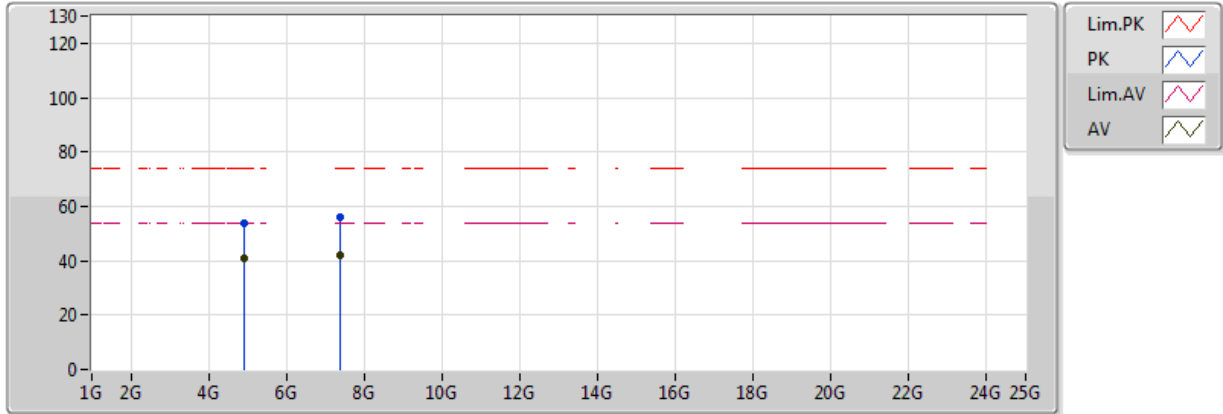

20170919
 EUT Y_2TX ANT Dipole
 Setting 19
 02-J-6
 FSU

| Type | Freq (Hz) | Level (dBuV/m) | Limit (dBuV/m) | Margin (dB) | Factor (dB) | Dist (m) | Condition | Azimuth (°) | Height (m) |
|------|-----------|----------------|----------------|-------------|-------------|----------|------------|-------------|------------|
| AV | 4.9255G | 40.76 | 54.00 | -13.24 | 9.17 | 3 | Horizontal | 278 | 1.44 |
| AV | 7.38462G | 42.24 | 54.00 | -11.76 | 13.07 | 3 | Horizontal | 295 | 1.02 |
| PK | 4.9198G | 53.80 | 74.00 | -20.20 | 9.15 | 3 | Horizontal | 278 | 1.44 |
| PK | 7.3938G | 56.23 | 74.00 | -17.77 | 13.09 | 3 | Horizontal | 295 | 1.02 |

802.11n HT20_Nss1,(MCS0)_2TX

2412MHz_TX

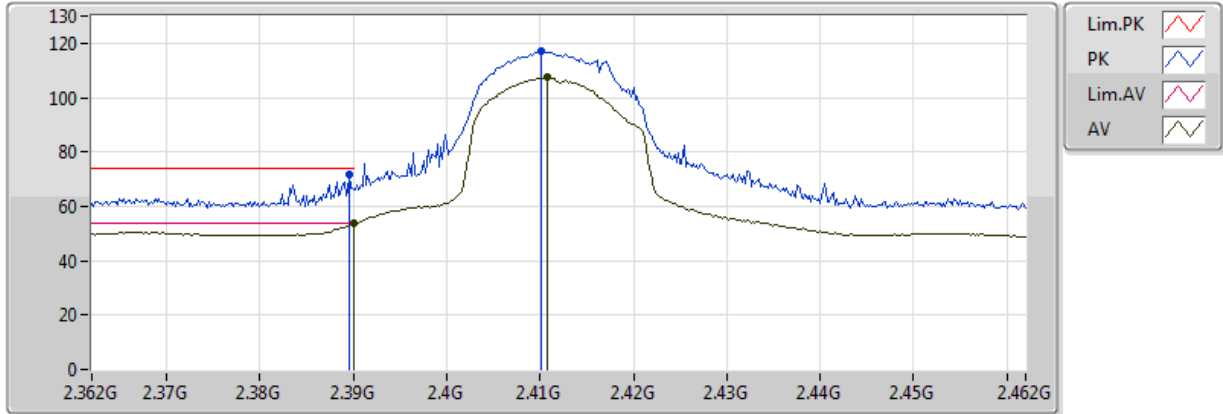

20170919
 EUT Y_2TX ANT Dipole
 Setting 18.5
 02-J-6
 FSU

| Type | Freq (Hz) | Level (dBuV/m) | Limit (dBuV/m) | Margin (dB) | Factor (dB) | Dist (m) | Condition | Azimuth (°) | Height (m) |
|------|-----------|----------------|----------------|-------------|-------------|----------|-----------|-------------|------------|
| AV | 2.39G | 53.64 | 54.00 | -0.36 | 32.13 | 3 | Vertical | 317 | 2.33 |
| AV | 2.4108G | 107.40 | Inf | -Inf | 32.19 | 3 | Vertical | 317 | 2.33 |
| PK | 2.3896G | 71.70 | 74.00 | -2.30 | 32.13 | 3 | Vertical | 317 | 2.33 |
| PK | 2.4102G | 117.10 | Inf | -Inf | 32.19 | 3 | Vertical | 317 | 2.33 |

802.11n HT20_Nss1,(MCS0)_2TX

2412MHz_TX

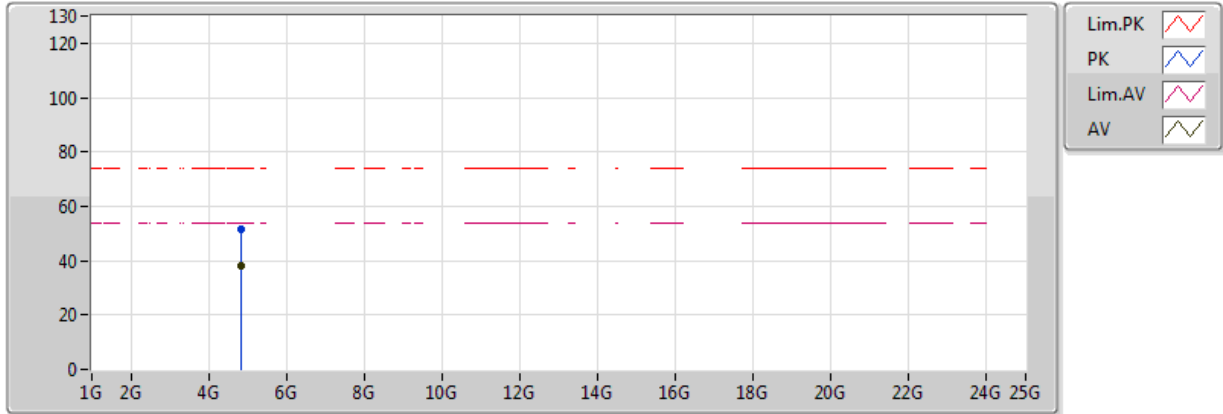

20170919
 EUT Y_2TX ANT Dipole
 Setting 18.5
 02-J-6
 FSU

| Type | Freq (Hz) | Level (dBuV/m) | Limit (dBuV/m) | Margin (dB) | Factor (dB) | Dist (m) | Condition | Azimuth (°) | Height (m) |
|------|-----------|----------------|----------------|-------------|-------------|----------|-----------|-------------|------------|
| AV | 4.81788G | 38.14 | 54.00 | -15.86 | 8.84 | 3 | Vertical | 108 | 2.06 |
| PK | 4.83174G | 51.39 | 74.00 | -22.61 | 8.88 | 3 | Vertical | 108 | 2.06 |

802.11n HT20_Nss1,(MCS0)_2TX

2412MHz_TX

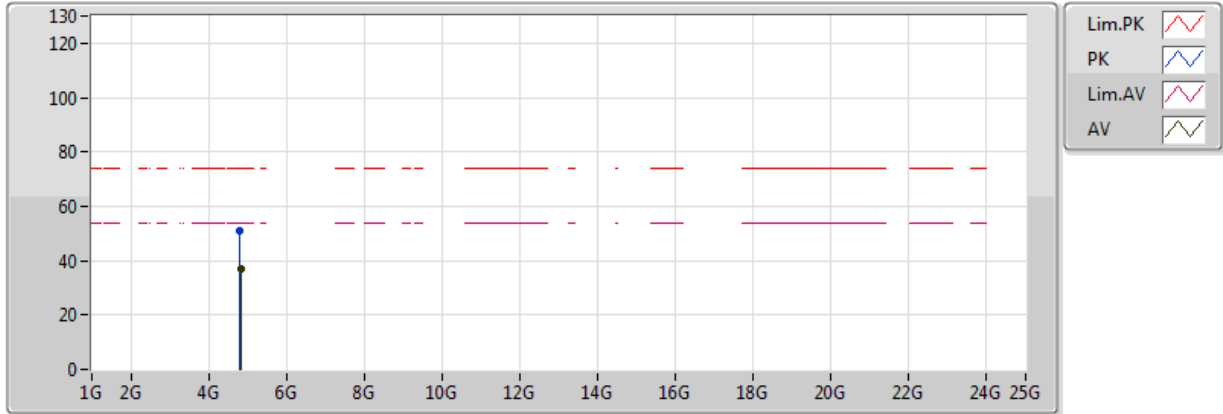

20170919
 EUT Y_2TX ANT Dipole
 Setting 18.5
 02-J-6
 FSU

| Type | Freq (Hz) | Level (dBuV/m) | Limit (dBuV/m) | Margin (dB) | Factor (dB) | Dist (m) | Condition | Azimuth (°) | Height (m) |
|------|-----------|----------------|----------------|-------------|-------------|----------|------------|-------------|------------|
| AV | 4.82784G | 37.04 | 54.00 | -16.96 | 8.87 | 3 | Horizontal | 236 | 1.35 |
| PK | 4.80978G | 50.92 | 74.00 | -23.08 | 8.81 | 3 | Horizontal | 236 | 1.35 |

802.11n HT20_Nss1,(MCS0)_2TX

2422MHz_TX

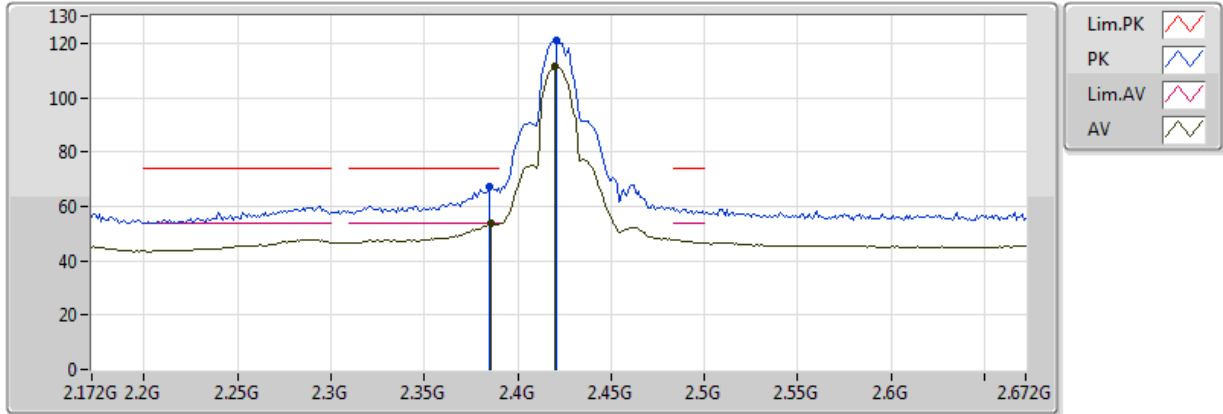

20170922
 EUT Y_2TX ANT Dipole
 Setting 24
 03-P-2
 FSP(100019)

| Type | Freq (Hz) | Level (dBuV/m) | Limit (dBuV/m) | Margin (dB) | Factor (dB) | Dist (m) | Condition | Azimuth (°) | Height (m) |
|------|-----------|----------------|----------------|-------------|-------------|----------|-----------|-------------|------------|
| AV | 2.386G | 53.68 | 54.00 | -0.32 | 31.90 | 3 | Vertical | 254 | 2.15 |
| AV | 2.42G | 111.70 | Inf | -Inf | 31.99 | 3 | Vertical | 254 | 2.15 |
| PK | 2.385G | 67.26 | 74.00 | -6.74 | 31.90 | 3 | Vertical | 254 | 2.15 |
| PK | 2.421G | 121.30 | Inf | -Inf | 31.99 | 3 | Vertical | 254 | 2.15 |

802.11n HT20_Nss1,(MCS0)_2TX 2437MHz_TX

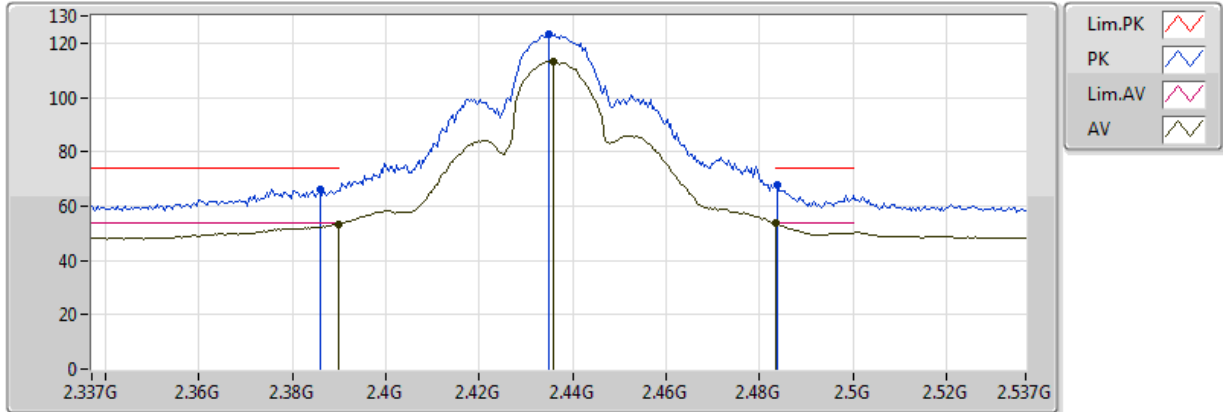

20170919
EUT Y_2TX ANT Dipole
Setting 29
02-J-6
FSU

| Type | Freq (Hz) | Level (dBuV/m) | Limit (dBuV/m) | Margin (dB) | Factor (dB) | Dist (m) | Condition | Azimuth (°) | Height (m) |
|------|-----------|----------------|----------------|-------------|-------------|----------|-----------|-------------|------------|
| AV | 2.389998G | 53.44 | 54.00 | -0.56 | 32.13 | 3 | Vertical | 154 | 2.79 |
| AV | 2.4358G | 113.45 | Inf | -Inf | 32.26 | 3 | Vertical | 154 | 2.79 |
| AV | 2.483502G | 53.85 | 54.00 | -0.15 | 32.40 | 3 | Vertical | 154 | 2.79 |
| PK | 2.3858G | 66.13 | 74.00 | -7.87 | 32.12 | 3 | Vertical | 154 | 2.79 |
| PK | 2.435G | 123.36 | Inf | -Inf | 32.26 | 3 | Vertical | 154 | 2.79 |
| PK | 2.4838G | 67.94 | 74.00 | -6.06 | 32.40 | 3 | Vertical | 154 | 2.79 |



802.11n HT20_Nss1,(MCS0)_2TX

2437MHz_TX

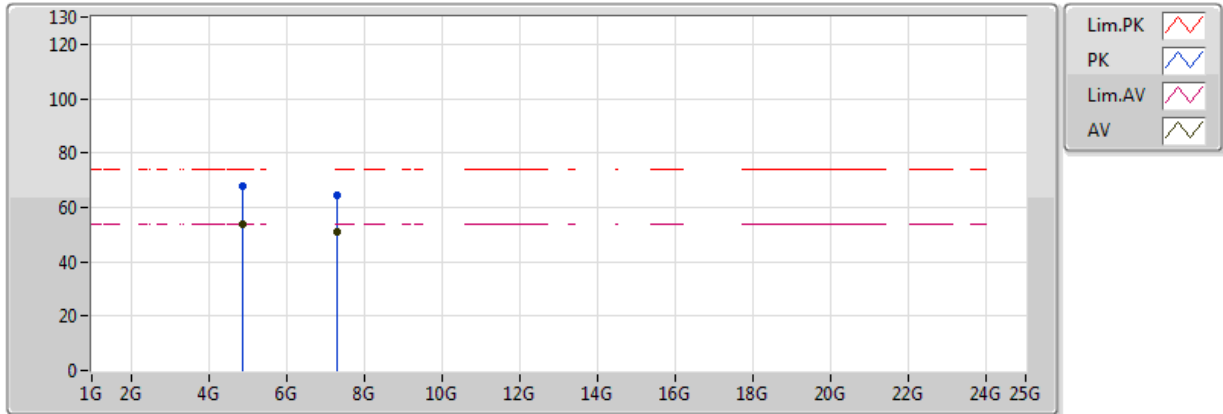

20170919
 EUT Y_2TX ANT Dipole
 Setting 29
 02-J-6
 FSU

| Type | Freq (Hz) | Level (dBuV/m) | Limit (dBuV/m) | Margin (dB) | Factor (dB) | Dist (m) | Condition | Azimuth (°) | Height (m) |
|------|-----------|----------------|----------------|-------------|-------------|----------|-----------|-------------|------------|
| AV | 4.87586G | 53.81 | 54.00 | -0.19 | 9.02 | 3 | Vertical | 116 | 1.09 |
| AV | 7.31172G | 51.06 | 54.00 | -2.94 | 12.91 | 3 | Vertical | 258 | 1.52 |
| PK | 4.8725G | 67.55 | 74.00 | -6.45 | 9.00 | 3 | Vertical | 116 | 1.09 |
| PK | 7.3125G | 64.44 | 74.00 | -9.56 | 12.91 | 3 | Vertical | 258 | 1.52 |

802.11n HT20_Nss1,(MCS0)_2TX

2437MHz_TX

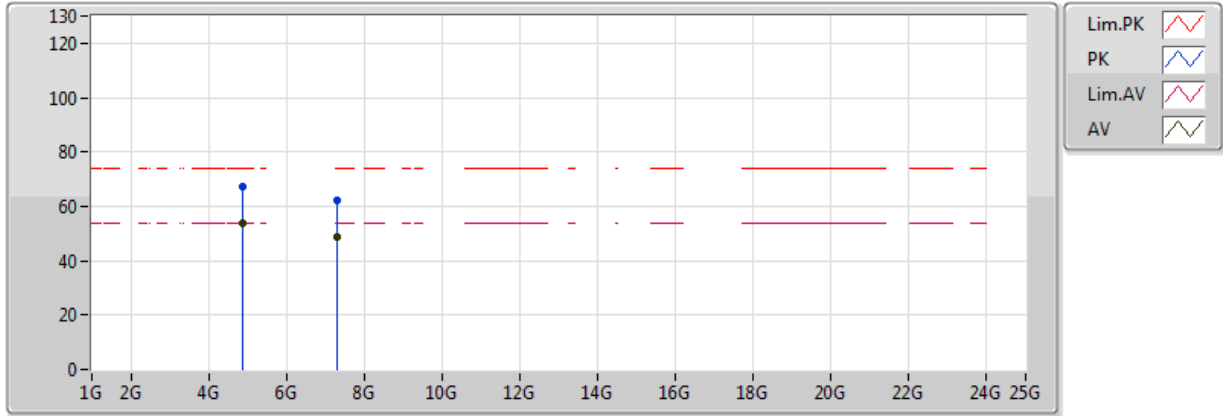

20170919
EUT Y_2TX ANT Dipole
Setting 29
02-J-6
FSU

| Type | Freq (Hz) | Level (dBuV/m) | Limit (dBuV/m) | Margin (dB) | Factor (dB) | Dist (m) | Condition | Azimuth (°) | Height (m) |
|------|--------------|-------------------|-------------------|----------------|----------------|-------------|------------|----------------|---------------|
| AV | 4.87538G | 53.54 | 54.00 | -0.46 | 9.01 | 3 | Horizontal | 262 | 1.50 |
| AV | 7.3119G | 48.48 | 54.00 | -5.52 | 12.91 | 3 | Horizontal | 125 | 1.37 |
| PK | 4.87256G | 67.36 | 74.00 | -6.64 | 9.00 | 3 | Horizontal | 262 | 1.50 |
| PK | 7.31112G | 62.21 | 74.00 | -11.79 | 12.90 | 3 | Horizontal | 125 | 1.37 |

802.11n HT20_Nss1,(MCS0)_2TX

2452MHz_TX

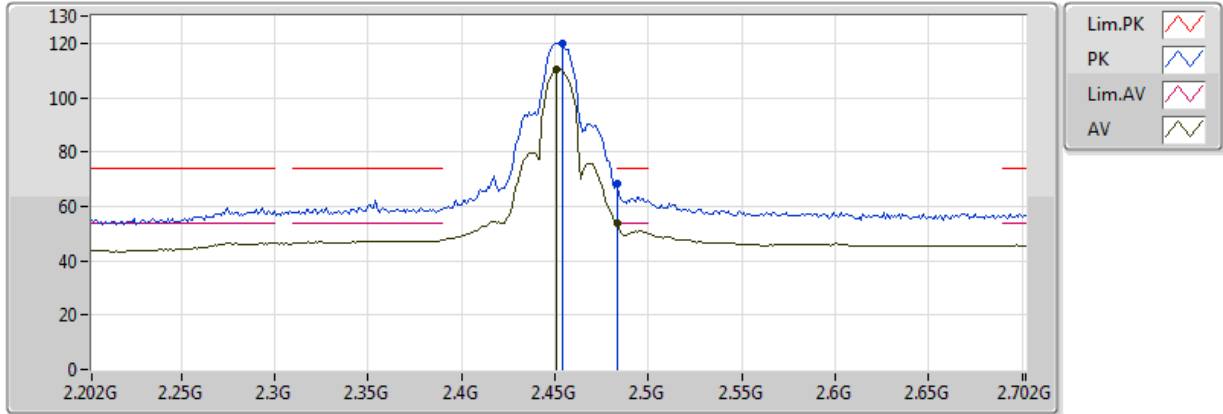

20170922
 EUT Y_2TX ANT Dipole
 Setting 25
 03-P-2
 FSP(100019)

| Type | Freq (Hz) | Level (dBuV/m) | Limit (dBuV/m) | Margin (dB) | Factor (dB) | Dist (m) | Condition | Azimuth (°) | Height (m) |
|------|-----------|----------------|----------------|-------------|-------------|----------|-----------|-------------|------------|
| AV | 2.451G | 110.60 | Inf | -Inf | 32.06 | 3 | Vertical | 90 | 2.56 |
| AV | 2.483502G | 53.72 | 54.00 | -0.28 | 32.14 | 3 | Vertical | 90 | 2.56 |
| PK | 2.454G | 119.95 | Inf | -Inf | 32.07 | 3 | Vertical | 90 | 2.56 |
| PK | 2.483502G | 68.23 | 74.00 | -5.77 | 32.14 | 3 | Vertical | 90 | 2.56 |

802.11n HT20_Nss1,(MCS0)_2TX

2462MHz_TX

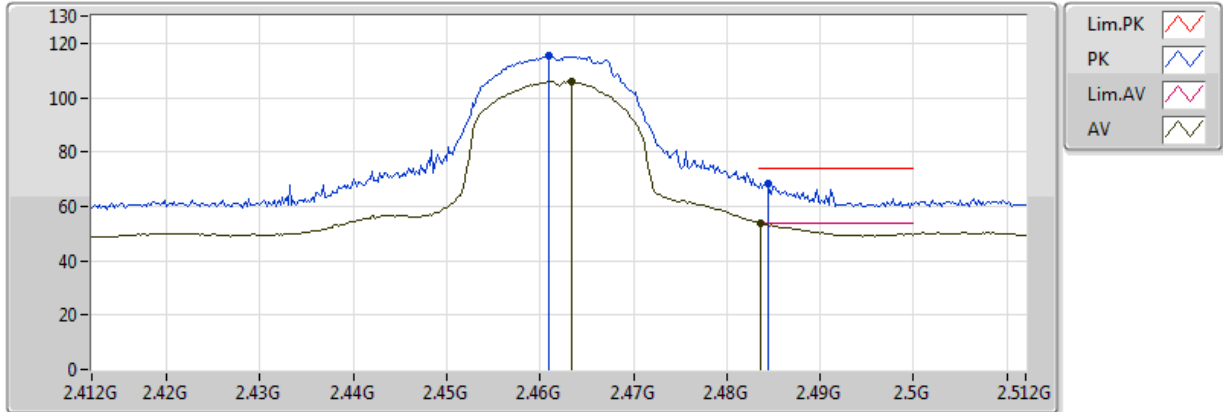

20170919
 EUT Y_2TX ANT Dipole
 Setting 19
 02-J-6
 FSU

| Type | Freq (Hz) | Level (dBuV/m) | Limit (dBuV/m) | Margin (dB) | Factor (dB) | Dist (m) | Condition | Azimuth (°) | Height (m) |
|------|-----------|----------------|----------------|-------------|-------------|----------|-----------|-------------|------------|
| AV | 2.4634G | 105.94 | Inf | -Inf | 32.34 | 3 | Vertical | 249 | 2.39 |
| AV | 2.4836G | 53.84 | 54.00 | -0.16 | 32.40 | 3 | Vertical | 249 | 2.39 |
| PK | 2.461G | 115.40 | Inf | -Inf | 32.34 | 3 | Vertical | 249 | 2.39 |
| PK | 2.4844G | 68.36 | 74.00 | -5.64 | 32.40 | 3 | Vertical | 249 | 2.39 |

802.11n HT20_Nss1,(MCS0)_2TX

2462MHz_TX

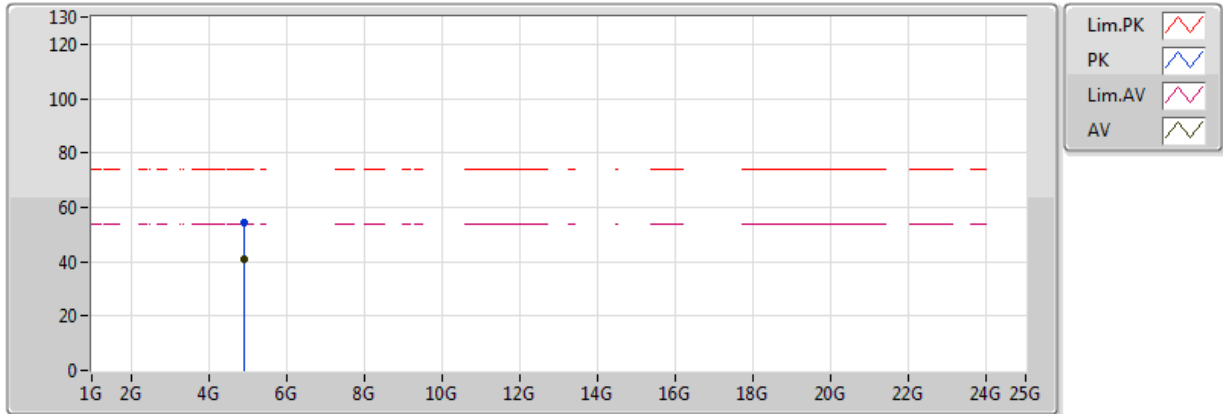

20170919
 EUT Y_2TX ANT Dipole
 Setting 19
 02-J-6
 FSU

| Type | Freq (Hz) | Level (dBuV/m) | Limit (dBuV/m) | Margin (dB) | Factor (dB) | Dist (m) | Condition | Azimuth (°) | Height (m) |
|------|-----------|----------------|----------------|-------------|-------------|----------|-----------|-------------|------------|
| AV | 4.92604G | 40.94 | 54.00 | -13.06 | 9.17 | 3 | Vertical | 271 | 1.50 |
| PK | 4.92436G | 54.37 | 74.00 | -19.63 | 9.16 | 3 | Vertical | 271 | 1.50 |

802.11n HT20_Nss1,(MCS0)_2TX

2462MHz_TX

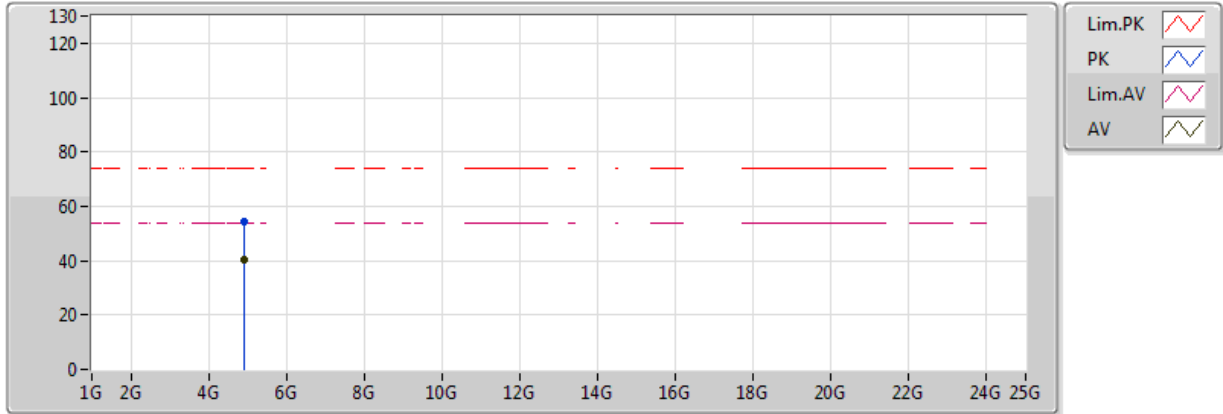

20170919
 EUT Y_2TX ANT Dipole
 Setting 19
 02-J-6
 FSU

| Type | Freq (Hz) | Level (dBuV/m) | Limit (dBuV/m) | Margin (dB) | Factor (dB) | Dist (m) | Condition | Azimuth (°) | Height (m) |
|------|-----------|----------------|----------------|-------------|-------------|----------|------------|-------------|------------|
| AV | 4.92802G | 40.60 | 54.00 | -13.40 | 9.17 | 3 | Horizontal | 266 | 1.58 |
| PK | 4.92988G | 54.15 | 74.00 | -19.85 | 9.18 | 3 | Horizontal | 266 | 1.58 |

802.11n HT40_Nss1,(MCS0)_2TX

2422MHz_TX

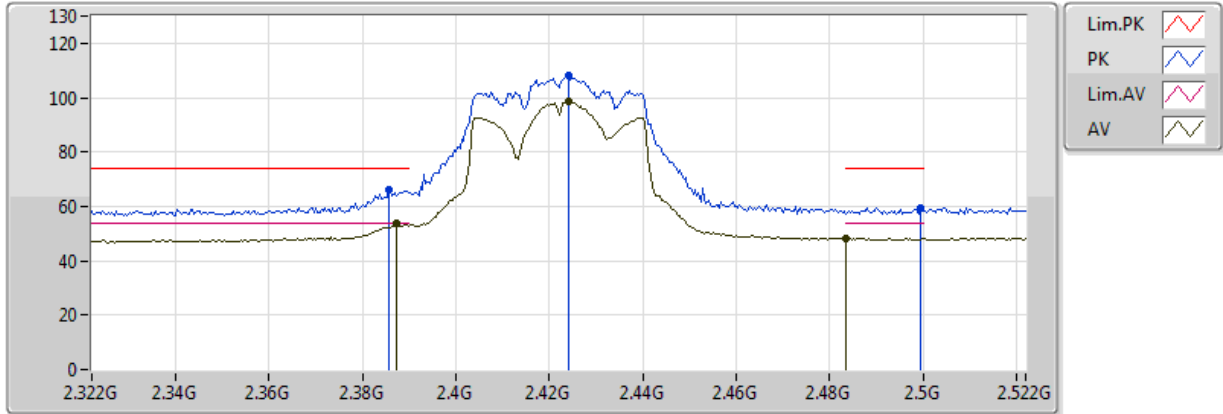

20170919
 EUT Y_2TX ANT Dipole
 Setting 15.5
 02-J-6
 FSU

| Type | Freq (Hz) | Level (dBuV/m) | Limit (dBuV/m) | Margin (dB) | Factor (dB) | Dist (m) | Condition | Azimuth (°) | Height (m) |
|------|-----------|----------------|----------------|-------------|-------------|----------|-----------|-------------|------------|
| AV | 2.3872G | 53.66 | 54.00 | -0.34 | 32.12 | 3 | Vertical | 210 | 1.50 |
| AV | 2.424G | 98.42 | Inf | -Inf | 32.23 | 3 | Vertical | 210 | 1.50 |
| AV | 2.4836G | 48.22 | 54.00 | -5.78 | 32.40 | 3 | Vertical | 210 | 1.50 |
| PK | 2.3856G | 65.85 | 74.00 | -8.15 | 32.12 | 3 | Vertical | 210 | 1.50 |
| PK | 2.424G | 107.87 | Inf | -Inf | 32.23 | 3 | Vertical | 210 | 1.50 |
| PK | 2.4996G | 59.54 | 74.00 | -14.46 | 32.45 | 3 | Vertical | 210 | 1.50 |

802.11n HT40_Nss1,(MCS0)_2TX

2422MHz_TX

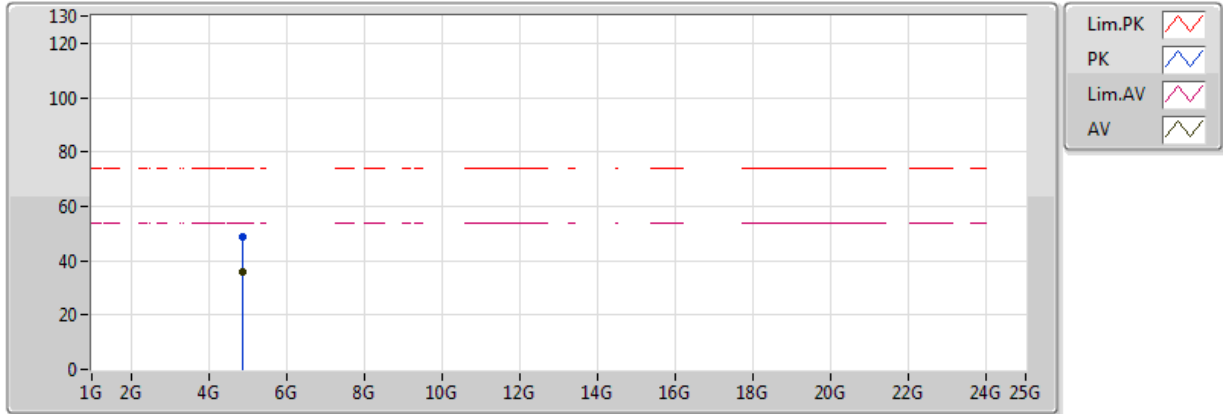

20170919
 EUT Y_2TX ANT Dipole
 Setting 15.5
 02-J-6
 FSU

| Type | Freq (Hz) | Level (dBuV/m) | Limit (dBuV/m) | Margin (dB) | Factor (dB) | Dist (m) | Condition | Azimuth (°) | Height (m) |
|------|-----------|----------------|----------------|-------------|-------------|----------|-----------|-------------|------------|
| AV | 4.85726G | 36.08 | 54.00 | -17.92 | 8.96 | 3 | Vertical | 307 | 2.19 |
| PK | 4.85894G | 48.47 | 74.00 | -25.53 | 8.96 | 3 | Vertical | 307 | 2.19 |

802.11n HT40_Nss1,(MCS0)_2TX

2422MHz_TX

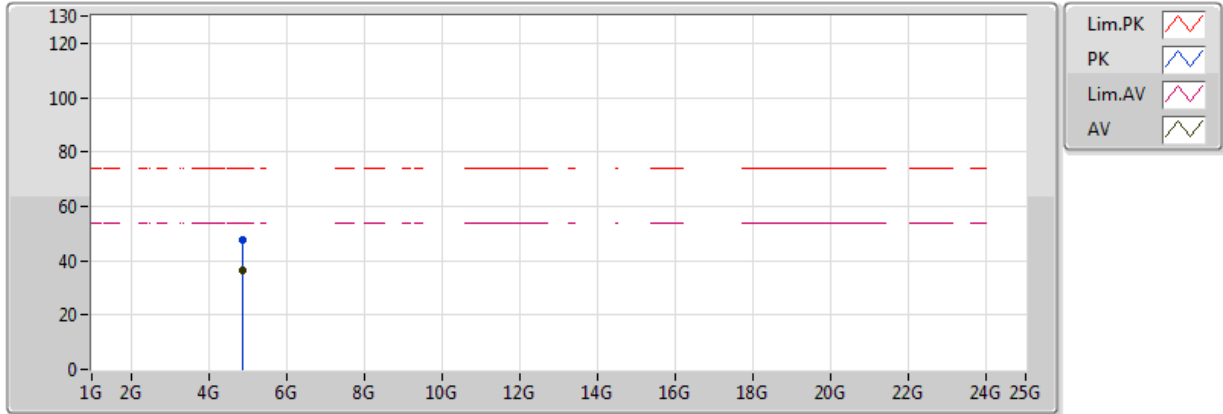

20170919
 EUT Y_2TX ANT Dipole
 Setting 15.5
 02-J-6
 FSU

| Type | Freq (Hz) | Level (dBuV/m) | Limit (dBuV/m) | Margin (dB) | Factor (dB) | Dist (m) | Condition | Azimuth (°) | Height (m) |
|------|-----------|----------------|----------------|-------------|-------------|----------|------------|-------------|------------|
| AV | 4.85864G | 36.27 | 54.00 | -17.73 | 8.96 | 3 | Horizontal | 130 | 2.37 |
| PK | 4.8584G | 47.73 | 74.00 | -26.27 | 8.96 | 3 | Horizontal | 130 | 2.37 |

802.11n HT40_Nss1,(MCS0)_2TX

2427MHz_TX

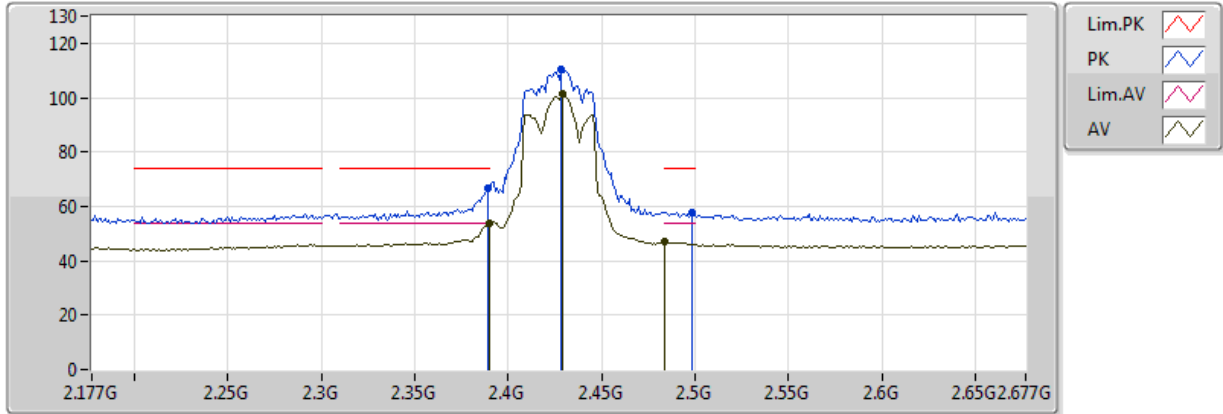

20170922
 EUT Y_2TX ANT Dipole
 Setting 17
 03-P-2
 FSP(100019)

| Type | Freq (Hz) | Level (dBuV/m) | Limit (dBuV/m) | Margin (dB) | Factor (dB) | Dist (m) | Condition | Azimuth (°) | Height (m) |
|------|-----------|----------------|----------------|-------------|-------------|----------|-----------|-------------|------------|
| AV | 2.39G | 53.69 | 54.00 | -0.31 | 31.91 | 3 | Vertical | 95 | 1.19 |
| AV | 2.429G | 101.31 | Inf | -Inf | 32.01 | 3 | Vertical | 95 | 1.19 |
| AV | 2.484G | 46.92 | 54.00 | -7.08 | 32.14 | 3 | Vertical | 95 | 1.19 |
| PK | 2.389G | 66.50 | 74.00 | -7.50 | 31.91 | 3 | Vertical | 95 | 1.19 |
| PK | 2.428G | 110.29 | Inf | -Inf | 32.01 | 3 | Vertical | 95 | 1.19 |
| PK | 2.498G | 57.99 | 74.00 | -16.01 | 32.18 | 3 | Vertical | 95 | 1.19 |

802.11n HT40_Nss1,(MCS0)_2TX

2437MHz_TX

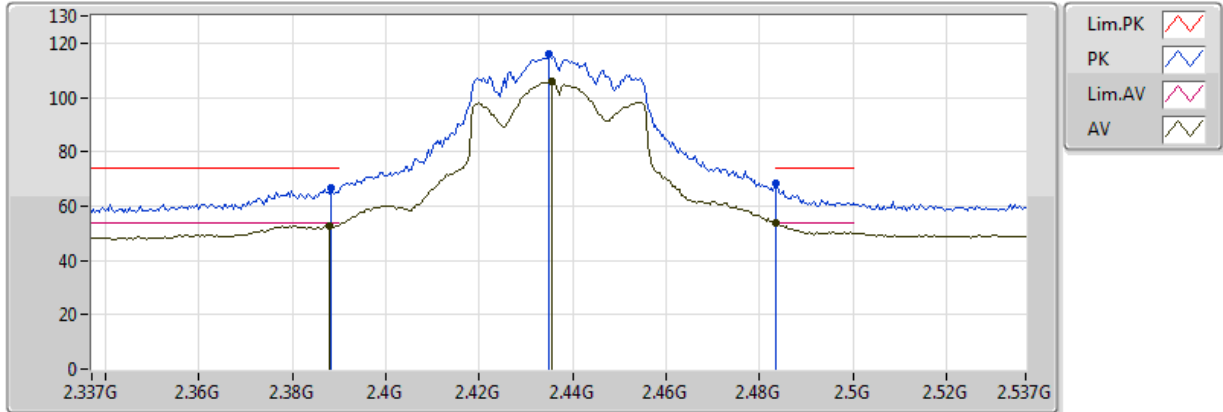

20170919
 EUT Y_2TX ANT Dipole
 Setting 21
 02-J-6
 FSU

| Type | Freq (Hz) | Level (dBuV/m) | Limit (dBuV/m) | Margin (dB) | Factor (dB) | Dist (m) | Condition | Azimuth (°) | Height (m) |
|------|-----------|----------------|----------------|-------------|-------------|----------|-----------|-------------|------------|
| AV | 2.3878G | 52.78 | 54.00 | -1.22 | 32.12 | 3 | Vertical | 129 | 2.67 |
| AV | 2.4354G | 105.66 | Inf | -Inf | 32.26 | 3 | Vertical | 129 | 2.67 |
| AV | 2.483502G | 53.90 | 54.00 | -0.10 | 32.40 | 3 | Vertical | 129 | 2.67 |
| PK | 2.3882G | 66.56 | 74.00 | -7.44 | 32.12 | 3 | Vertical | 129 | 2.67 |
| PK | 2.435G | 116.02 | Inf | -Inf | 32.26 | 3 | Vertical | 129 | 2.67 |
| PK | 2.483502G | 68.21 | 74.00 | -5.79 | 32.40 | 3 | Vertical | 129 | 2.67 |

802.11n HT40_Nss1,(MCS0)_2TX

2437MHz_TX

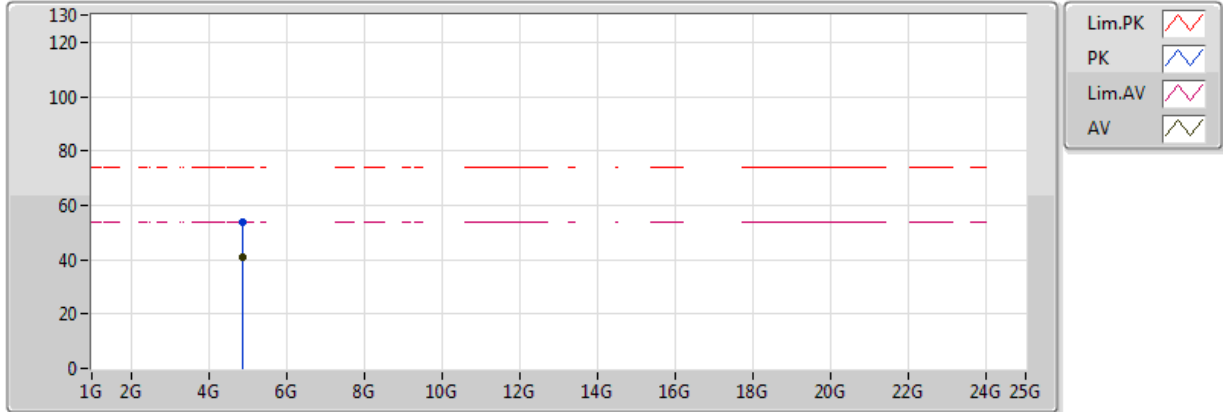

20170919
 EUT Y_2TX ANT Dipole
 Setting 21
 02-J-6
 FSU

| Type | Freq (Hz) | Level (dBuV/m) | Limit (dBuV/m) | Margin (dB) | Factor (dB) | Dist (m) | Condition | Azimuth (°) | Height (m) |
|------|-----------|----------------|----------------|-------------|-------------|----------|-----------|-------------|------------|
| AV | 4.87892G | 40.70 | 54.00 | -13.30 | 9.02 | 3 | Vertical | 100 | 2.55 |
| PK | 4.88G | 53.86 | 74.00 | -20.14 | 9.03 | 3 | Vertical | 100 | 2.55 |

802.11n HT40_Nss1,(MCS0)_2TX

2437MHz_TX

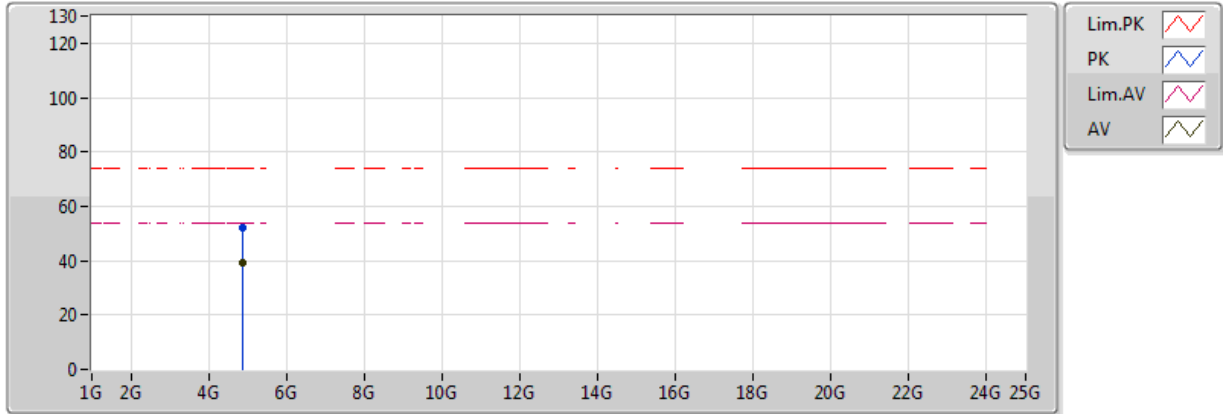

20170919
 EUT Y_2TX ANT Dipole
 Setting 21
 02-J-6
 FSU

| Type | Freq (Hz) | Level (dBuV/m) | Limit (dBuV/m) | Margin (dB) | Factor (dB) | Dist (m) | Condition | Azimuth (°) | Height (m) |
|------|-----------|----------------|----------------|-------------|-------------|----------|------------|-------------|------------|
| AV | 4.87904G | 39.23 | 54.00 | -14.77 | 9.03 | 3 | Horizontal | 94 | 1.48 |
| PK | 4.8809G | 52.08 | 74.00 | -21.92 | 9.03 | 3 | Horizontal | 94 | 1.48 |

802.11n HT40_Nss1,(MCS0)_2TX

2447MHz_TX

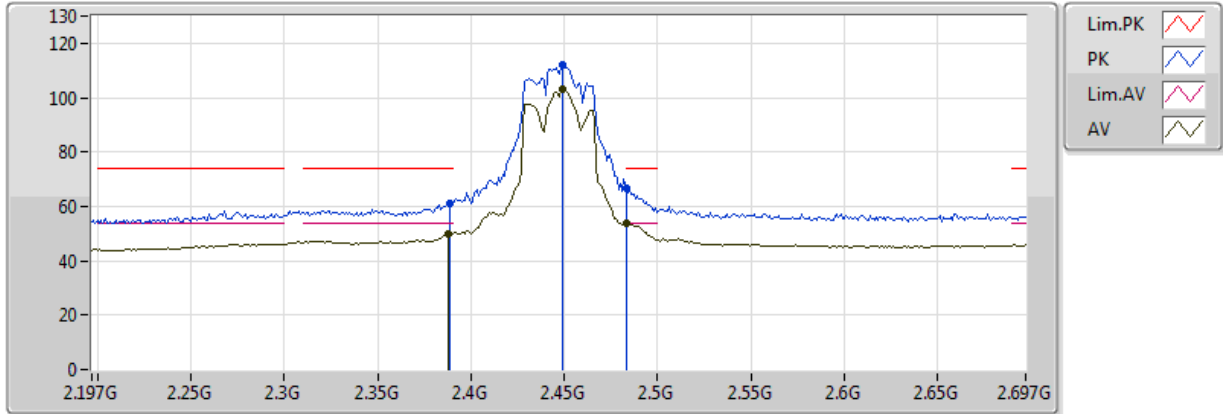

20170922
 EUT Y_2TX ANT Dipole
 Setting 19.5
 03-P-2
 FSP(100019)

| Type | Freq (Hz) | Level (dBuV/m) | Limit (dBuV/m) | Margin (dB) | Factor (dB) | Dist (m) | Condition | Azimuth (°) | Height (m) |
|------|-----------|----------------|----------------|-------------|-------------|----------|-----------|-------------|------------|
| AV | 2.388G | 50.12 | 54.00 | -3.88 | 31.91 | 3 | Vertical | 70 | 1.50 |
| AV | 2.449G | 103.16 | Inf | -Inf | 32.06 | 3 | Vertical | 70 | 1.50 |
| AV | 2.483502G | 53.85 | 54.00 | -0.15 | 32.14 | 3 | Vertical | 70 | 1.50 |
| PK | 2.389G | 61.04 | 74.00 | -12.96 | 31.91 | 3 | Vertical | 70 | 1.50 |
| PK | 2.449G | 112.17 | Inf | -Inf | 32.06 | 3 | Vertical | 70 | 1.50 |
| PK | 2.483502G | 66.86 | 74.00 | -7.14 | 32.14 | 3 | Vertical | 70 | 1.50 |

802.11n HT40_Nss1,(MCS0)_2TX

2452MHz_TX

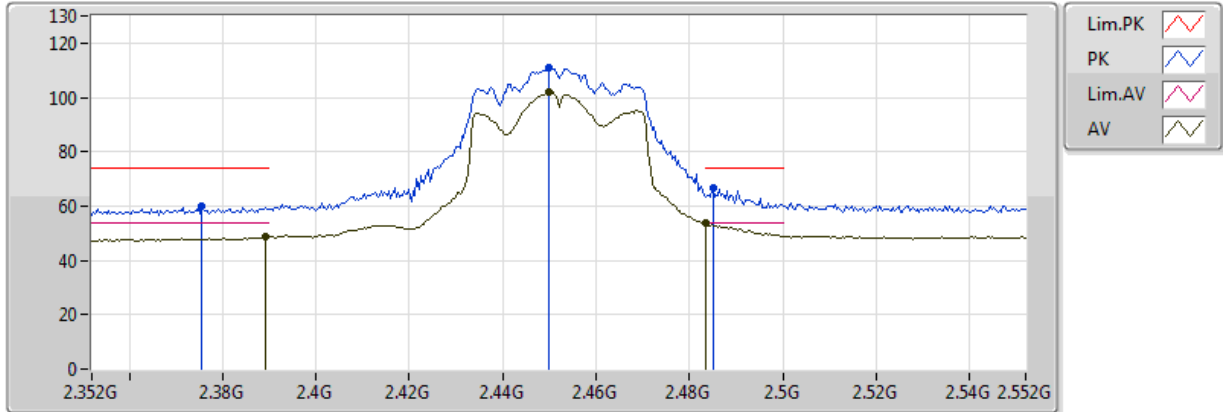

20170919
 EUT_Y_2TX ANT Dipole
 Setting 17
 02-J-6
 FSU

| Type | Freq (Hz) | Level (dBuV/m) | Limit (dBuV/m) | Margin (dB) | Factor (dB) | Dist (m) | Condition | Azimuth (°) | Height (m) |
|------|-----------|----------------|----------------|-------------|-------------|----------|-----------|-------------|------------|
| AV | 2.3892G | 48.47 | 54.00 | -5.53 | 32.13 | 3 | Vertical | 274 | 2.16 |
| AV | 2.45G | 102.01 | Inf | -Inf | 32.30 | 3 | Vertical | 274 | 2.16 |
| AV | 2.4836G | 53.66 | 54.00 | -0.34 | 32.40 | 3 | Vertical | 274 | 2.16 |
| PK | 2.3756G | 59.71 | 74.00 | -14.29 | 32.08 | 3 | Vertical | 274 | 2.16 |
| PK | 2.45G | 110.97 | Inf | -Inf | 32.30 | 3 | Vertical | 274 | 2.16 |
| PK | 2.4852G | 66.63 | 74.00 | -7.37 | 32.41 | 3 | Vertical | 274 | 2.16 |

802.11n HT40_Nss1,(MCS0)_2TX

2452MHz_TX

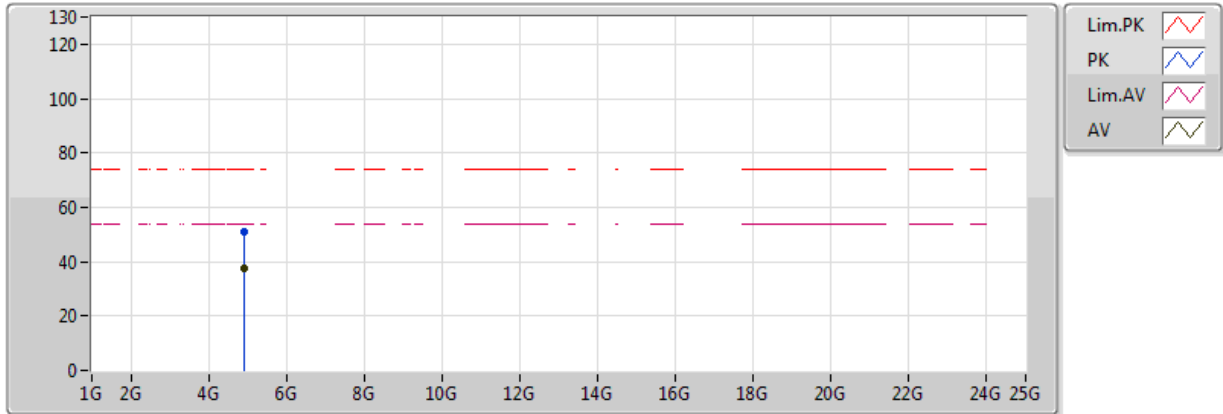

20170919
 EUT Y_2TX ANT Dipole
 Setting 17
 02-J-6
 FSU

| Type | Freq (Hz) | Level (dBuV/m) | Limit (dBuV/m) | Margin (dB) | Factor (dB) | Dist (m) | Condition | Azimuth (°) | Height (m) |
|------|-----------|----------------|----------------|-------------|-------------|----------|-----------|-------------|------------|
| AV | 4.90684G | 37.78 | 54.00 | -16.22 | 9.11 | 3 | Vertical | 251 | 1.30 |
| PK | 4.90532G | 50.91 | 74.00 | -23.09 | 9.11 | 3 | Vertical | 251 | 1.30 |

802.11n HT40_Nss1,(MCS0)_2TX

2452MHz_TX

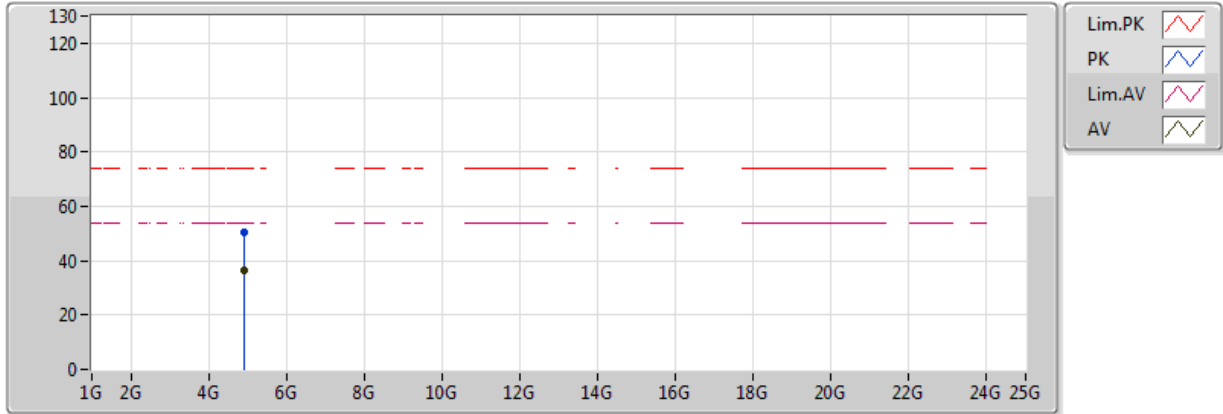

20170919
 EUT Y_2TX ANT Dipole
 Setting 17
 02-J-6
 FSU

| Type | Freq (Hz) | Level (dBuV/m) | Limit (dBuV/m) | Margin (dB) | Factor (dB) | Dist (m) | Condition | Azimuth (°) | Height (m) |
|------|-----------|----------------|----------------|-------------|-------------|----------|------------|-------------|------------|
| AV | 4.90952G | 36.46 | 54.00 | -17.54 | 9.12 | 3 | Horizontal | 245 | 1.50 |
| PK | 4.90512G | 50.42 | 74.00 | -23.58 | 9.11 | 3 | Horizontal | 245 | 1.50 |



RSE Co-location Result

Appendix G

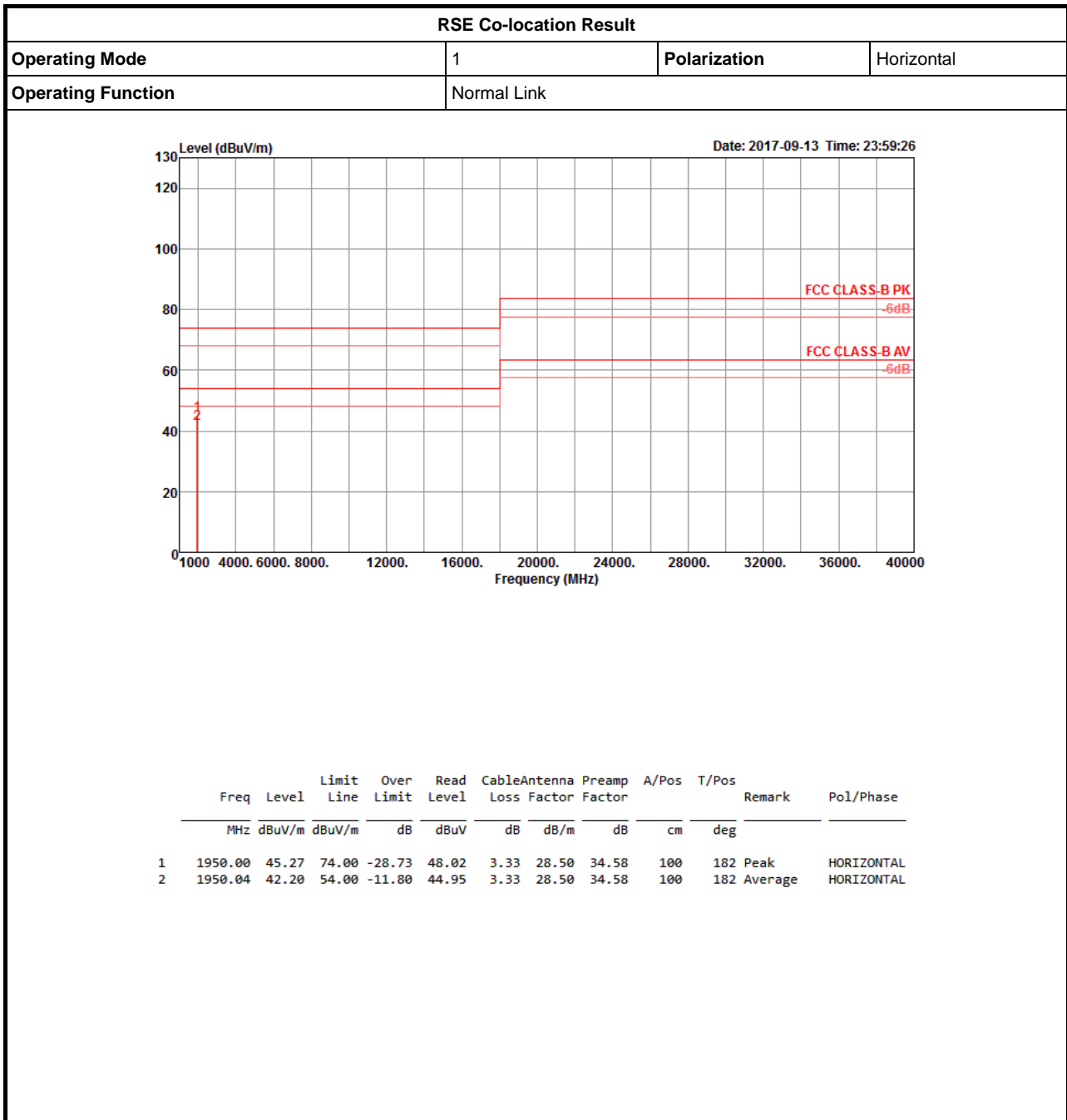



RSE Co-location Result

