

# FCC Radio Test Report

## FCC ID: TE7C80

This report concerns: **Original Grant**

**Project No.** : 1907C038  
**Equipment** : AC1900 MU-MIMO Wi-Fi Router  
**Brand Name** : tp-link  
**Test Model** : Archer C80  
**Series Model** : N/A  
**Applicant** : TP-Link Technologies Co., Ltd.  
**Address** : Building 24(floors1,3,4,5) and 28(floors1-4) Central Science and Technology Park, Shennan Rd, Nanshan, Shenzhen, China  
**Manufacturer** : TP-Link Technologies Co., Ltd.  
**Address** : Building 24(floors1,3,4,5) and 28(floors1-4) Central Science and Technology Park, Shennan Rd, Nanshan, Shenzhen, China  
**Date of Receipt** : Jul. 03, 2019  
**Date of Test** : Jul. 05, 2019 ~ Nov. 12, 2019  
**Issued Date** : Nov. 12, 2019  
**Report Version** : R02  
**Test Sample** : Engineering Sample No.: DG190703116 for conducted, DG190703117 for radiated.  
**Standard(s)** : FCC Part15, Subpart E(15.407)  
ANSI C63.10-2013  
FCC KDB 789033 D02 General UNII Test Procedures New Rules v02r01  
FCC KDB 662911 D01 Multiple Transmitter Output v02r01

The above equipment has been tested and found compliance with the requirement of the relative standards by BTL Inc.



Prepared by : Kai Xu



Approved by : Ethan Ma



Certificate #5123.02

Add: No.3, Jinshagang 1<sup>st</sup> Road, Shixia, Dalang Town, Dongguan, Guangdong, China.

Tel: +86-769-8318-3000

Web: [www.newbtl.com](http://www.newbtl.com)

**Declaration**

**BTL** represents to the client that testing is done in accordance with standard procedures as applicable and that test instruments used has been calibrated with standards traceable to international standard(s) and/or national standard(s).

**BTL's** reports apply only to the specific samples tested under conditions. It is manufacture's responsibility to ensure that additional production units of this model are manufactured with the identical electrical and mechanical components. **BTL** shall have no liability for any declarations, inferences or generalizations drawn by the client or others from **BTL** issued reports.

The report must not be used by the client to claim product certification, approval, or endorsement by NIST, A2LA, or any agency of the U.S. Government.

This report is the confidential property of the client. As a mutual protection to the clients, the public and ourselves, the test report shall not be reproduced, except in full, without our written approval.

**BTL's** laboratory quality assurance procedures are in compliance with the **ISO/IEC 17025** requirements, and accredited by the conformity assessment authorities listed in this test report.

**BTL** is not responsible for the sampling stage, so the results only apply to the sample as received.

The information, data and test plan are provided by manufacturer which may affect the validity of results, so it is manufacturer's responsibility to ensure that the apparatus meets the essential requirements of applied standards and in all the possible configurations as representative of its intended use.

**Limitation**

For the use of the authority's logo is limited unless the Test Standard(s)/Scope(s)/Item(s) mentioned in this test report is (are) included in the conformity assessment authorities acceptance respective.

Please note that the measurement uncertainty is provided for informational purpose only and are not use in determining the Pass/Fail results.

<b>Table of Contents</b>	<b>Page</b>
<b>REPORT ISSUED HISTORY</b>	<b>6</b>
<b>1 . SUMMARY OF TEST RESULTS</b>	<b>7</b>
1.1 TEST FACILITY	8
1.2 MEASUREMENT UNCERTAINTY	8
1.3 TEST ENVIRONMENT CONDITIONS	8
<b>2 . GENERAL INFORMATION</b>	<b>9</b>
2.1 GENERAL DESCRIPTION OF EUT	9
2.2 TEST MODES	11
2.3 PARAMETERS OF TEST SOFTWARE	15
2.4 DUTY CYCLE	17
2.5 BLOCK DIAGRAM SHOWING THE CONFIGURATION OF SYSTEM TESTED	19
2.6 SUPPORT UNITS	19
<b>3 . AC POWER LINE CONDUCTED EMISSIONS TEST</b>	<b>20</b>
3.1 LIMIT	20
3.2 TEST PROCEDURE	20
3.3 DEVIATION FROM TEST STANDARD	20
3.4 TEST SETUP	21
3.5 EUT OPERATION CONDITIONS	21
3.6 TEST RESULTS	21
<b>4 . RADIATED EMISSIONS TEST</b>	<b>22</b>
4.1 LIMIT	22
4.2 TEST PROCEDURE	23
4.3 DEVIATION FROM TEST STANDARD	23
4.4 TEST SETUP	24
4.5 EUT OPERATION CONDITIONS	25
4.6 TEST RESULTS – 9 KHZ to 30 MHZ	25
4.7 TEST RESULTS – 30 MHz TO 1000 MHz	25
4.8 TEST RESULTS – ABOVE 1000 MHz	25
<b>5 . BANDWIDTH TEST</b>	<b>26</b>
5.1 LIMIT	26
5.2 TEST PROCEDURE	26
5.3 DEVIATION FROM STANDARD	26

<b>Table of Contents</b>	<b>Page</b>
<b>5.4 TEST SETUP</b>	<b>27</b>
<b>5.5 EUT OPERATION CONDITIONS</b>	<b>27</b>
<b>5.6 TEST RESULTS</b>	<b>27</b>
<b>6 . MAXIMUM OUTPUT POWER TEST</b>	<b>28</b>
<b>6.1 LIMIT</b>	<b>28</b>
<b>6.2 TEST PROCEDURE</b>	<b>28</b>
<b>6.3 DEVIATION FROM STANDARD</b>	<b>28</b>
<b>6.4 TEST SETUP</b>	<b>28</b>
<b>6.5 EUT OPERATION CONDITIONS</b>	<b>28</b>
<b>6.6 TEST RESULTS</b>	<b>28</b>
<b>7 . POWER SPECTRAL DENSITY TEST</b>	<b>29</b>
<b>7.1 LIMIT</b>	<b>29</b>
<b>7.2 TEST PROCEDURE</b>	<b>29</b>
<b>7.3 DEVIATION FROM STANDARD</b>	<b>29</b>
<b>7.4 TEST SETUP</b>	<b>30</b>
<b>7.5 EUT OPERATION CONDITIONS</b>	<b>30</b>
<b>7.6 TEST RESULTS</b>	<b>30</b>
<b>8 . FREQUENCY STABILITY MEASUREMENT</b>	<b>31</b>
<b>8.1 LIMIT</b>	<b>31</b>
<b>8.2 TEST PROCEDURE</b>	<b>31</b>
<b>8.3 DEVIATION FROM STANDARD</b>	<b>31</b>
<b>8.4 TEST SETUP</b>	<b>32</b>
<b>8.5 EUT OPERATION CONDITIONS</b>	<b>32</b>
<b>8.6 TEST RESULTS</b>	<b>32</b>
<b>9 . MEASUREMENT INSTRUMENTS LIST</b>	<b>33</b>
<b>10 . EUT TEST PHOTOS</b>	<b>35</b>
<b>APPENDIX A – AC POWER LINE CONDUCTED EMISSIONS</b>	<b>39</b>
<b>APPENDIX B – RADIATED EMISSION – 9 KHZ TO 30 MHZ</b>	<b>42</b>
<b>APPENDIX C – RADIATED EMISSION – 30 MHZ TO 1 GHZ</b>	<b>47</b>
<b>APPENDIX D – RADIATED EMISSION – ABOVE 1000 MHZ</b>	<b>50</b>
<b>APPENDIX E – BANDWIDTH</b>	<b>171</b>
<b>APPENDIX F – MAXIMUM OUTPUT POWER</b>	<b>182</b>

<b>Table of Contents</b>	<b>Page</b>
<b>APPENDIX G – POWER SPECTRAL DENSITY</b>	<b>205</b>
<b>APPENDIX H – FREQUENCY STABILITY</b>	<b>222</b>

**REPORT ISSUED HISTORY**

Report Version	Description	Issued Date
R00	Original Issue.	Oct. 29, 2019
R01	Added the data of OBW for N Mode.	Nov. 06, 2019
R02	Updated the data of 99% OBW for AC 80 Mode	Nov. 12, 2019

## 1. SUMMARY OF TEST RESULTS

Test procedures according to the technical standard(s):

FCC Part15, Subpart E(15.407)				
Standard(s) Section	Test Item	Test Result	Judgement	Remark
15.207 15.407(b)	AC Power Line Conducted Emissions	APPENDIX A	PASS	-----
15.407(b) 15.205(a) 15.209(a)	Radiated Emissions	APPENDIX B APPENDIX C APPENDIX D	PASS	-----
15.407(a) 15.407(e)	Spectrum Bandwidth	APPENDIX E	PASS	-----
15.407(a)	Maximum Output Power	APPENDIX F	PASS	-----
15.407(a)	Power Spectral Density	APPENDIX G	PASS	-----
15.407(g)	Frequency Stability	APPENDIX H	PASS	-----
15.203	Antenna Requirements	-----	PASS	Note(4)
15.407(c)	Automatically Discontinue Transmission	-----	PASS	Note(2)

**Note:**

- (1) "N/A" denotes test is not applicable in this test report.
- (2) During no any information transmission, the EUT can automatically discontinue transmission and become standby mode for power saving. the EUT can detect the controlling signal of ACK message transmitting from remote device and verify whether it shall resend or discontinue transmission.
- (3) For UNII-1 this device was functioned as a  
 Access point device     Client device
- (4) The device what use a permanently attached antenna were considered sufficient to comply with the provisions of 15.203.

### 1.1 TEST FACILITY

The test facilities used to collect the test data in this report is at the location of No.3, Jinshagang 1st Road, Shixia, Dalang Town, Dongguan, Guangdong, China.

BTL's Test Firm Registration Number for FCC: 357015

BTL's Designation Number for FCC: CN1240

### 1.2 MEASUREMENT UNCERTAINTY

ISO/IEC 17025 requires that an estimate of the measurement uncertainties associated with the emissions test results be included in the report. The measurement uncertainties given below are based on a 95% confidence level (based on a coverage factor (k=2))

The BTL measurement uncertainty as below table:

A. AC power line conducted emissions test:

Test Site	Method	Measurement Frequency Range	U, (dB)
DG-C02	CISPR	150 kHz ~ 30 MHz	2.32

B. Radiated emissions test:

Test Site	Method	Measurement Frequency Range	Ant. H / V	U, (dB)
DG-CB03	CISPR	9kHz ~ 30MHz	V	3.79
		9kHz ~ 30MHz	H	3.57
		30MHz ~ 200MHz	V	4.88
		30MHz ~ 200MHz	H	4.14
		200MHz ~ 1,000MHz	V	4.62
		200MHz ~ 1,000MHz	H	4.80
		1GHz ~ 6GHz	-	4.58
		6GHz ~ 18GHz	-	5.18
		18GHz ~ 26.5GHz	-	3.80
		26.5GHz ~ 40GHz	-	4.30

Note: Unless specifically mentioned, the uncertainty of measurement has not been taken into account to declare the compliance or non-compliance to the specification.

### 1.3 TEST ENVIRONMENT CONDITIONS

Test Item	Temperature	Humidity	Test Voltage	Tested By
AC Power Line Conducted Emissions	25°C	53%	AC 120V/60Hz	Robin Zhuang
Radiated Emissions-9K-30MHz	25°C	60%	AC 120V/60Hz	Robin Zhuang
Radiated Emissions-30 MHz to 1GHz	24°C	68%	AC 120V/60Hz	Laughing Zhang
Radiated Emissions-Above 1000 MHz	27°C	63%	AC 120V/60Hz	Laughing Zhang
Spectrum Bandwidth	27°C	56%	AC 120V/60Hz	Jonas Chen
Maximum Output Power	27°C	56%	AC 120V/60Hz	Jonas Chen
Power Spectral Density	27°C	56%	AC 120V/60Hz	Jonas Chen
Frequency Stability	27°C	56%	AC 120V/60Hz	Jonas Chen



## 2. GENERAL INFORMATION

### 2.1 GENERAL DESCRIPTION OF EUT

Equipment	AC1900 MU-MIMO Wi-Fi Router
Brand Name	tp-link
Test Model	Archer C80
Series Model	N/A
Model Difference(s)	N/A
Power Source	DC voltage supplied from AC/DC adapter. Model: T120150-2B1
Power Rating	I/P: 100-240V~ 50/60Hz, 0.6A      O/P: 12V  1.5A
Operation Frequency	UNII-1: 5150 MHz~5250 MHz UNII-3: 5725 MHz~5850 MHz
Modulation Type	OFDM
Bit Rate of Transmitter	Up to 1300 Mbps
Maximum Output Power for UNII-1 Non Beamforming	IEEE 802.11a: 25.70 dBm (0.3715 W) IEEE 802.11n (HT20): 25.70 dBm (0.3715 W) IEEE 802.11n (HT40): 26.53 dBm (0.4498 W) IEEE 802.11ac (VHT20): 25.89 dBm (0.3882 W) IEEE 802.11ac (VHT40): 26.57 dBm (0.4539 W) IEEE 802.11ac (VHT80): 18.94 dBm (0.0783 W)
Maximum Output Power for UNII-3 Non Beamforming	IEEE 802.11a: 27.38 dBm (0.5470 W) IEEE 802.11n (HT20): 27.22 dBm (0.5272 W) IEEE 802.11n (HT40): 27.88 dBm (0.6138 W) IEEE 802.11ac (VHT20): 27.41 dBm (0.5508 W) IEEE 802.11ac (VHT40): 28.10 dBm (0.6457 W) IEEE 802.11ac (VHT80): 23.32 dBm (0.2148 W)
Maximum Output Power for UNII-1 With Beamforming	IEEE 802.11n (HT20): 25.54 dBm (0.3581 W) IEEE 802.11n (HT40): 26.41 dBm (0.4375 W) IEEE 802.11ac (VHT20): 25.59 dBm (0.3622 W) IEEE 802.11ac (VHT40): 26.46 dBm (0.4426 W) IEEE 802.11ac (VHT80): 19.39 dBm (0.0869 W)
Maximum Output Power for UNII-3 With Beamforming	IEEE 802.11n (HT20): 26.98 dBm (0.4989 W) IEEE 802.11n (HT40): 27.83 dBm (0.6067 W) IEEE 802.11ac (VHT20): 27.07 dBm (0.5093 W) IEEE 802.11ac (VHT40): 27.85 dBm (0.6095 W) IEEE 802.11ac (VHT80): 23.50 dBm (0.2239 W)

Note:



- For a more detailed features description, please refer to the manufacturer's specifications or the user's manual.

## 2. Channel List:

IEEE 802.11a IEEE 802.11n (HT20) IEEE 802.11ac (VHT20)		IEEE 802.11n (HT40) IEEE 802.11ac (VHT40)		IEEE 802.11ac (VHT80)	
UNII-1		UNII-1		UNII-1	
Channel	Frequency (MHz)	Channel	Frequency (MHz)	Channel	Frequency (MHz)
36	5180	38	5190	42	5210
40	5200	46	5230		
44	5220				
48	5240				

IEEE 802.11a IEEE 802.11n (HT20) IEEE 802.11ac (VHT20)		IEEE 802.11n (HT40) IEEE 802.11ac (VHT40)		IEEE 802.11ac (VHT80)	
UNII-3		UNII-3		UNII-3	
Channel	Frequency (MHz)	Channel	Frequency (MHz)	Channel	Frequency (MHz)
149	5745	151	5755	155	5775
153	5765	159	5795		
157	5785				
161	5805				
165	5825				

## 3. Antenna Specification:

Ant.	Brand	P/N	Antenna Type	Connector	Gain (dBi)
1		3101502665	Dipole	Weld	3
2		3101502664	Dipole	Weld	3
3		3101502663	Dipole	Weld	3

## Note:

This EUT supports CDD, and all antennas have the same gain, Directional gain =  $G_{ANT} + \text{Array Gain}$ , where Array Gain is as follows:

## (1) Non Beamforming Function,

For power spectral density measurements,  $N_{ANT} = 3$ ,  $N_{SS} = 1$ . So Directional gain =  $G_{ANT} + \text{Array Gain} = 10 \log(N_{ANT}/N_{SS}) \text{ dB} = 3 + 10 \log(3/1) \text{ dB} = 7.77$ .

Then, the UNII-1 power spectral density limit is  $17 - (7.77 - 6) = 15.23$ , the UNII-3 power density limit is  $30 - (7.77 - 6) = 28.23$ .

For power measurements, Array Gain = 0 dB ( $N_{ANT} \leq 4$ ), so the Directional gain = 3.

 (2) Beamforming Function, Beamforming Gain: 4.77 dB. So Directional gain =  $4.77 + 3 = 7.77$ .

Then, the UNII-1 and UNII-3 output power limit is  $30 - (7.77 - 6) = 28.23$ ; the UNII-1 power density limit is  $17 - (7.77 - 6) = 15.23$ , the UNII-3 power density limit is  $30 - (7.77 - 6) = 28.23$ .

## 2.2 TEST MODES

The test system was pre-tested based on the consideration of all possible combinations of EUT operation mode.

Pretest Mode	Description
Mode 1	TX A Mode / CH36, CH40, CH48 (UNII-1)
Mode 2	TX N (HT20) Mode / CH36, CH40, CH48 (UNII-1)
Mode 3	TX N (HT40) Mode / CH38, CH46 (UNII-1)
Mode 4	TX AC (VHT20) Mode / CH36, CH40, CH48 (UNII-1)
Mode 5	TX AC (VHT40) Mode / CH38, CH46 (UNII-1)
Mode 6	TX AC (VHT80) Mode / CH42 (UNII-1)
Mode 7	TX A Mode / CH149,CH157,CH165 (UNII-3)
Mode 8	TX N (HT20) Mode / CH149,CH157,CH165 (UNII-3)
Mode 9	TX N (HT40) Mode / CH151,CH159 (UNII-3)
Mode 10	TX AC (VHT20) Mode / CH149,CH157,CH165 (UNII-3)
Mode 11	TX AC (VHT40) Mode / CH151,CH159 (UNII-3)
Mode 12	TX AC (VHT80) Mode / CH155 (UNII-3)
Mode 13	TX AC(VHT40) Mode / CH159 (UNII-3)

Following mode(s) as (were) found to be the worst case(s) and selected for the final test.

<b>AC power line conducted emissions test</b>	
Final Test Mode	Description
Mode 13	TX AC(VHT40) Mode / CH159 (UNII-3)

<b>Radiated emissions test - below 1GHz</b>	
Final Test Mode	Description
Mode 13	TX AC(VHT40) Mode / CH159 (UNII-3)

<b>Radiated emissions test for Non Beamforming</b>	
Final Test Mode	Description
Mode 1	TX A Mode / CH36, CH40, CH48 (UNII-1)
Mode 4	TX AC (VHT20) Mode / CH36, CH40, CH48 (UNII-1)
Mode 5	TX AC (VHT40) Mode / CH38, CH46 (UNII-1)
Mode 6	TX AC (VHT80) Mode / CH42 (UNII-1)
Mode 7	TX A Mode / CH149,CH157,CH165 (UNII-3)
Mode 10	TX AC (VHT20) Mode / CH149,CH157,CH165 (UNII-3)
Mode 11	TX AC (VHT40) Mode / CH151,CH159 (UNII-3)
Mode 12	TX AC (VHT80) Mode / CH155 (UNII-3)

<b>Radiated emissions test for With Beamforming</b>	
Final Test Mode	Description
Mode 4	TX AC (VHT20) Mode / CH36, CH40, CH48 (UNII-1)
Mode 5	TX AC (VHT40) Mode / CH38, CH46 (UNII-1)
Mode 6	TX AC (VHT80) Mode / CH42 (UNII-1)
Mode 10	TX AC (VHT20) Mode / CH149,CH157,CH165 (UNII-3)
Mode 11	TX AC (VHT40) Mode / CH151,CH159 (UNII-3)
Mode 12	TX AC (VHT80) Mode / CH155 (UNII-3)

<b>Output power test for Non Beamforming</b>	
Final Test Mode	Description
Mode 1	TX A Mode / CH36, CH40, CH48 (UNII-1)
Mode 2	TX N (HT20) Mode / CH36, CH40, CH48 (UNII-1)
Mode 3	TX N (HT40) Mode / CH38, CH46 (UNII-1)
Mode 4	TX AC (VHT20) Mode / CH36, CH40, CH48 (UNII-1)
Mode 5	TX AC (VHT40) Mode / CH38, CH46 (UNII-1)
Mode 6	TX AC (VHT80) Mode / CH42 (UNII-1)
Mode 7	TX A Mode / CH149,CH157,CH165 (UNII-3)
Mode 8	TX N (HT20) Mode / CH149,CH157,CH165 (UNII-3)
Mode 9	TX N (HT40) Mode / CH151,CH159 (UNII-3)
Mode 10	TX AC (VHT20) Mode / CH149,CH157,CH165 (UNII-3)
Mode 11	TX AC (VHT40) Mode / CH151,CH159 (UNII-3)
Mode 12	TX AC (VHT80) Mode / CH155 (UNII-3)

<b>Output power test for With Beamforming</b>	
Final Test Mode	Description
Mode 2	TX N (HT20) Mode / CH36, CH40, CH48 (UNII-1)
Mode 3	TX N (HT40) Mode / CH38, CH46 (UNII-1)
Mode 4	TX AC (VHT20) Mode / CH36, CH40, CH48 (UNII-1)
Mode 5	TX AC (VHT40) Mode / CH38, CH46 (UNII-1)
Mode 6	TX AC (VHT80) Mode / CH42 (UNII-1)
Mode 8	TX N (HT20) Mode / CH149,CH157,CH165 (UNII-3)
Mode 9	TX N (HT40) Mode / CH151,CH159 (UNII-3)
Mode 10	TX AC (VHT20) Mode / CH149,CH157,CH165 (UNII-3)
Mode 11	TX AC (VHT40) Mode / CH151,CH159 (UNII-3)
Mode 12	TX AC (VHT80) Mode / CH155 (UNII-3)

Spectrum Bandwidth test for Non Beamforming	
Final Test Mode	Description
Mode 1	TX A Mode / CH36, CH40, CH48 (UNII-1)
Mode 2	TX N (HT20) Mode / CH36, CH40, CH48 (UNII-1)
Mode 3	TX N (HT40) Mode / CH38, CH46 (UNII-1)
Mode 4	TX AC (VHT20) Mode / CH36, CH40, CH48 (UNII-1)
Mode 5	TX AC (VHT40) Mode / CH38, CH46 (UNII-1)
Mode 6	TX AC (VHT80) Mode / CH42 (UNII-1)
Mode 7	TX A Mode / CH149,CH157,CH165 (UNII-3)
Mode 8	TX N (HT20) Mode / CH149,CH157,CH165 (UNII-3)
Mode 9	TX N (HT40) Mode / CH151,CH159 (UNII-3)
Mode 10	TX AC (VHT20) Mode / CH149,CH157,CH165 (UNII-3)
Mode 11	TX AC (VHT40) Mode / CH151,CH159 (UNII-3)
Mode 12	TX AC (VHT80) Mode / CH155 (UNII-3)

Other conducted test for Non Beamforming	
Final Test Mode	Description
Mode 1	TX A Mode / CH36, CH40, CH48 (UNII-1)
Mode 4	TX AC (VHT20) Mode / CH36, CH40, CH48 (UNII-1)
Mode 5	TX AC (VHT40) Mode / CH38, CH46 (UNII-1)
Mode 6	TX AC (VHT80) Mode / CH42 (UNII-1)
Mode 7	TX A Mode / CH149,CH157,CH165 (UNII-3)
Mode 10	TX AC (VHT20) Mode / CH149,CH157,CH165 (UNII-3)
Mode 11	TX AC (VHT40) Mode / CH151,CH159 (UNII-3)
Mode 12	TX AC (VHT80) Mode / CH155 (UNII-3)

Other conducted test for With Beamforming	
Final Test Mode	Description
Mode 4	TX AC (VHT20) Mode / CH36, CH40, CH48 (UNII-1)
Mode 5	TX AC (VHT40) Mode / CH38, CH46 (UNII-1)
Mode 6	TX AC (VHT80) Mode / CH42 (UNII-1)
Mode 10	TX AC (VHT20) Mode / CH149,CH157,CH165 (UNII-3)
Mode 11	TX AC (VHT40) Mode / CH151,CH159 (UNII-3)
Mode 12	TX AC (VHT80) Mode / CH155 (UNII-3)

**Note:**

- (1) For radiated emission below 1 GHz test, the IEEE 802.11ac40 channel 159 is found to be the worst case and recorded.
- (2) All the bit rate of transmitter have been tested and found the lowest rate is found to be the worst case and recorded.
- (3) For radiated emission above 1 GHz test, 1GHz~26.5GHz and 26.5GHz~40GHz have been pre-tested and in this report only recorded the worst case. The remaining spurious points are all below the limit value of 20dB.
- (4) The measurements for Power were tested, the worst case were IEEE 802.11a mode, IEEE 802.11ac (VHT20) mode, IEEE 802.11ac (VHT40) mode and IEEE 802.11ac(VHT80) mode, only worst case were documented for other test items.

**2.3 PARAMETERS OF TEST SOFTWARE**
**Non Beamforming**

UNII-1			
Test Software	ATool_V1.0.1		
Test Frequency (MHz)	5180	5200	5240
IEEE 802.11a	35	35	35
IEEE 802.11n (HT20)	35	35	35
IEEE 802.11ac (VHT20)	35	35	35
Test Frequency (MHz)	5190	5230	
IEEE 802.11n (HT40)	31	39	
IEEE 802.11ac (VHT40)	31	39	
Test Frequency (MHz)	5210		
IEEE 802.11ac (VHT80)	24		

UNII-3			
Test Software	ATool_V1.0.1		
Test Frequency (MHz)	5745	5785	5825
IEEE 802.11a	44	44	44
IEEE 802.11n (HT20)	43	43	43
IEEE 802.11ac (VHT20)	43	43	43
Test Frequency (MHz)	5755	5795	
IEEE 802.11n (HT40)	44	44	
IEEE 802.11ac (VHT40)	44	44	
Test Frequency (MHz)	5775		
IEEE 802.11ac (VHT80)	35		

**With Beamforming**

UNII-1			
Test Software	ATool_V1.0.1		
Test Frequency (MHz)	5180	5200	5240
IEEE 802.11n (HT20)	33	35	35
IEEE 802.11ac (VHT20)	33	35	35
Test Frequency (MHz)	5190	5230	
IEEE 802.11n (HT40)	26	39	
IEEE 802.11ac (VHT40)	26	39	
Test Frequency (MHz)	5210		
IEEE 802.11ac (VHT80)	23		

UNII-3			
Test Software	ATool_V1.0.1		
Test Frequency (MHz)	5745	5785	5825
IEEE 802.11n (HT20)	43	43	43
IEEE 802.11ac (VHT20)	43	43	43
Test Frequency (MHz)	5755	5795	
IEEE 802.11n (HT40)	44	44	
IEEE 802.11ac (VHT40)	44	44	
Test Frequency (MHz)	5775		
IEEE 802.11ac (VHT80)	33		



## 2.4 DUTY CYCLE

If duty cycle is  $\geq 98\%$ , duty factor is not required.  
 If duty cycle is  $< 98\%$ , duty factor shall be considered.  
 The output power = measured power + duty factor.

**IEEE 802.11a**

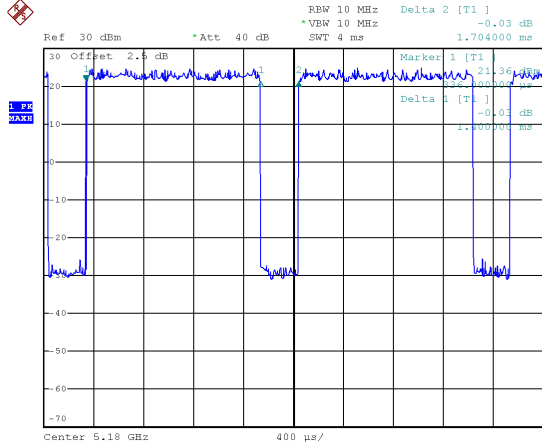

Date: 8.JUL.2019 21:30:54

Duty cycle =  $1.400 \text{ ms} / 1.704 \text{ ms} = 82.16\%$   
 Duty Factor =  $10\log(1/\text{Duty cycle}) = 0.85$

**IEEE 802.11n (HT20)**

**IEEE 802.11n (HT20)**

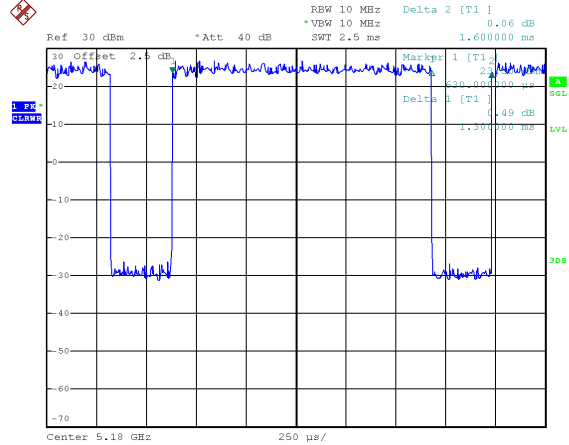

Date: 8.JUL.2019 21:31:51

Duty cycle =  $1.300 \text{ ms} / 1.600 \text{ ms} = 81.25\%$   
 Duty Factor =  $10\log(1/\text{Duty cycle}) = 0.90$

**IEEE 802.11n (HT40)**

**IEEE 802.11ac (VHT20)**

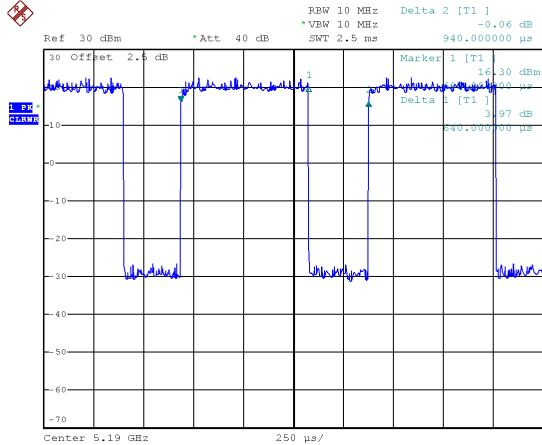

Date: 8.JUL.2019 21:32:56

Duty cycle =  $0.640 \text{ ms} / 0.940 \text{ ms} = 68.09\%$   
 Duty Factor =  $10\log(1/\text{Duty cycle}) = 1.67$

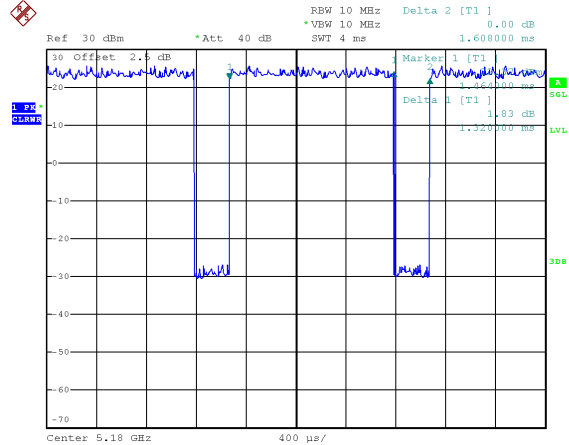

Date: 8.JUL.2019 21:32:17

Duty cycle =  $1.320 \text{ ms} / 1.608 \text{ ms} = 82.09\%$   
 Duty Factor =  $10\log(1/\text{Duty cycle}) = 0.86$

### IEEE 802.11ac (VHT40)

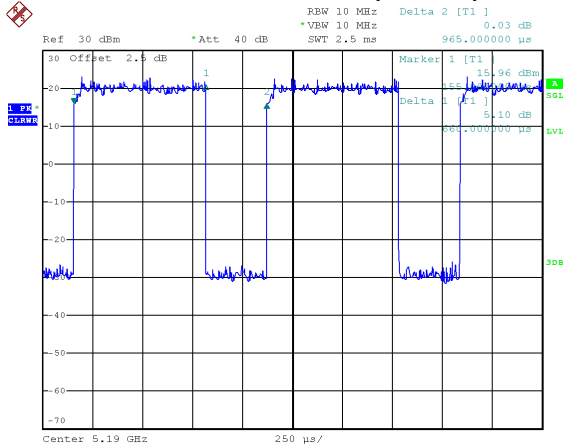

Date: 8.JUL.2019 21:33:29

Duty cycle = 0.660 ms/0.965 ms = 68.39%  
 Duty Factor =  $10\log(1/\text{Duty cycle}) = 1.65$

### IEEE 802.11ac (VHT80)

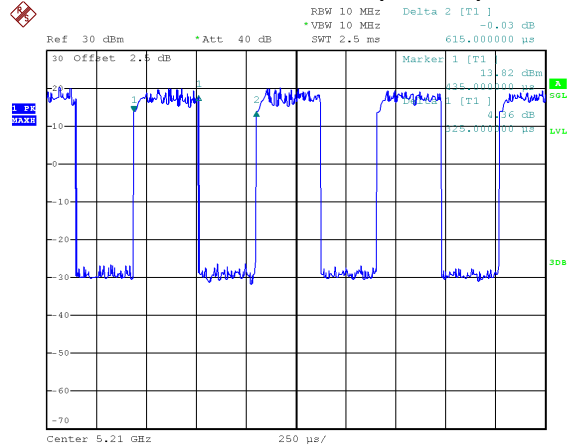

Date: 8.JUL.2019 21:34:37

Duty cycle = 0.325 ms/0.615 ms = 52.85%  
 Duty Factor =  $10\log(1/\text{Duty cycle}) = 2.77$

#### NOTE:

For IEEE 802.11a, IEEE 802.11n (HT20) and IEEE 802.11ac (VHT20):

For radiated emissions frequency above 1 GHz, the resolution bandwidth of test receiver/spectrum analyzer is 1 MHz and the video bandwidth is 1 kHz (Duty cycle < 98%).

For IEEE 802.11n (HT40) and IEEE 802.11ac (VHT40):

For radiated emissions frequency above 1 GHz, the resolution bandwidth of test receiver/spectrum analyzer is 1 MHz and the video bandwidth is 2 kHz (Duty cycle < 98%).

For IEEE 802.11ac (VHT80):

For radiated emissions frequency above 1 GHz, the resolution bandwidth of test receiver/spectrum analyzer is 1 MHz and the video bandwidth is 3 kHz (Duty cycle < 98%).

## 2.5 BLOCK DIAGRAM SHOWING THE CONFIGURATION OF SYSTEM TESTED

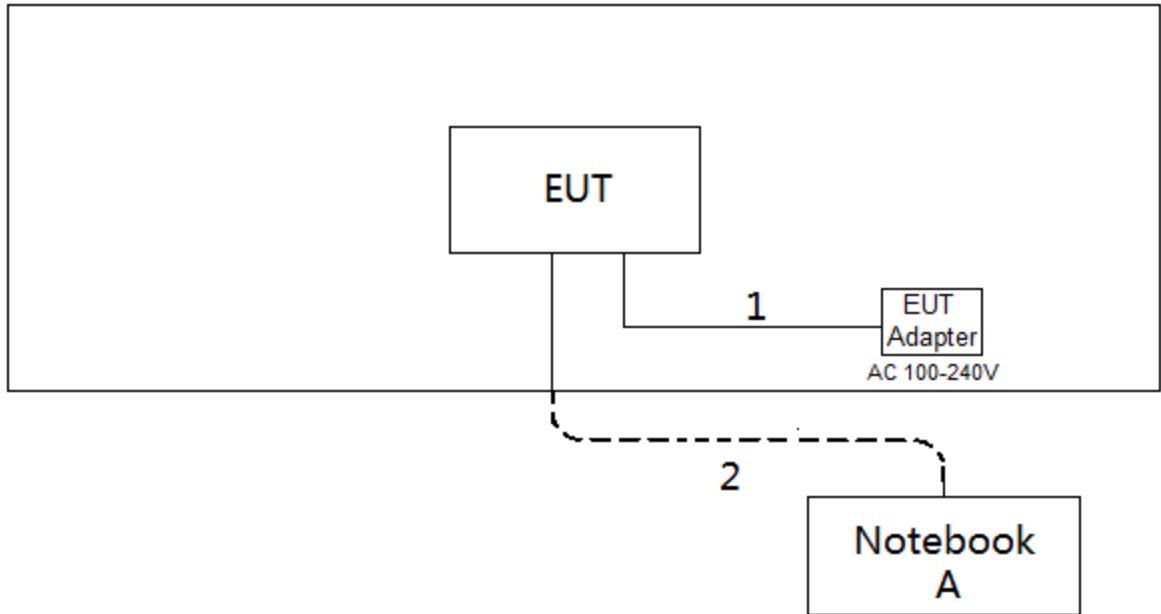

## 2.6 SUPPORT UNITS

Item	Equipment	Brand	Model No.	Series No.
A	Notebook	Dell	Inspiron 15-7559	N/A

Item	Cable Type	Shielded Type	Ferrite Core	Length
1	DC Cable	NO	NO	1.5m
2	RJ45 Cable	NO	NO	10m

### 3. AC POWER LINE CONDUCTED EMISSIONS TEST

#### 3.1 LIMIT

Frequency (MHz)	Limit (dBµV)	
	Quasi-peak	Average
0.15 - 0.50	66 to 56*	56 to 46*
0.50 - 5.0	56	46
5.0 - 30.0	60	50

NOTE:

- (1) The tighter limit applies at the band edges.
- (2) The limit of " \* " marked band means the limitation decreases linearly with the logarithm of the frequency in the range.

The following table is the setting of the receiver

Receiver Parameter	Setting
Attenuation	10 dB
Start Frequency	0.15 MHz
Stop Frequency	30 MHz
IF Bandwidth	9 KHz

#### 3.2 TEST PROCEDURE

- a. The EUT was placed 0.8 meters from the horizontal ground plane with EUT being connected to the power mains through a line impedance stabilization network (LISN). All other support equipment powered from additional LISN(s). The LISN provide 50 Ohm/ 50uH of coupling impedance for the measuring instrument.
- b. Interconnecting cables that hang closer than 40 cm to the ground plane shall be folded back and forth in the center forming a bundle 30 to 40 cm long.
- c. I/O cables that are not connected to a peripheral shall be bundled in the center. The end of the cable may be terminated, if required, using the correct terminating impedance. The overall length shall not exceed 1 m.
- d. LISN at least 80 cm from nearest part of EUT chassis.
- e. For the actual test configuration, please refer to the related Item -EUT Test Photos.

#### 3.3 DEVIATION FROM TEST STANDARD

No deviation

### 3.4 TEST SETUP

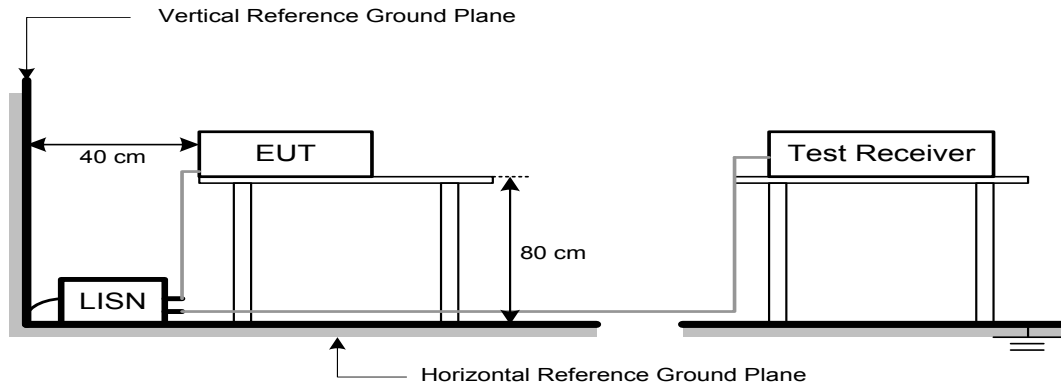

### 3.5 EUT OPERATION CONDITIONS

The EUT was configured for testing in a typical fashion (as a customer would normally use it). The EUT has been programmed to continuously transmit during test. This operating condition was tested and used to collect the included data.

The EUT was programmed to be in continuously transmitting/TX mode.

### 3.6 TEST RESULTS

Please refer to the APPENDIX A.

## 4. RADIATED EMISSIONS TEST

### 4.1 LIMIT

In case the emission fall within the restricted band specified on 15.205(a), then the 15.209(a) limit in the table below has to be followed.

#### LIMITS OF RADIATED EMISSIONS MEASUREMENT (9 kHz to 1000 MHz)

Frequency (MHz)	Field Strength (microvolts/meter)	Measurement Distance (meters)
0.009-0.490	2400/F(kHz)	300
0.490-1.705	24000/F(kHz)	30
1.705-30.0	30	30
30-88	100	3
88-216	150	3
216-960	200	3
Above 960	500	3

#### LIMITS OF UNWANTED EMISSION OUT OF THE RESTRICTED BANDS

Frequency (MHz)	EIRP Limit (dBm/MHz)	Equivalent Field Strength at 3m (dBμV/m)
5150-5250	-27	68.3
5725-5850	-27 NOTE (2)	68.3
	10 NOTE (2)	105.3
	15.6 NOTE (2)	110.9
	27 NOTE (2)	122.3

#### NOTE:

(1) The following formula is used to convert the equipment isotropic radiated power (eirp) to field

strength:  $E = \frac{1000000\sqrt{30P}}{3}$  μV/m, where P is the eirp (Watts)

(2) According to 15.407(b)(4)(i), all emissions shall be limited to a level of -27 dBm/MHz at 75 MHz or more above or below the band edge increasing linearly to 10 dBm/MHz at 25 MHz above or below the band edge, and from 25 MHz above or below the band edge increasing linearly to a level of 15.6 dBm/MHz at 5 MHz above or below the band edge, and from 5 MHz above or below the band edge increasing linearly to a level of 27 dBm/MHz at the band edge.

## 4.2 TEST PROCEDURE

- a. The measuring distance of 3 m shall be used for measurements. The EUT was placed on the top of a rotating table 0.8 meter above the ground at a 3 meter semi-anechoic chamber. The table was rotated 360 degrees to determine the position of the highest radiation.(below 1GHz)
- b. The measuring distance of 3 m shall be used for measurements. The EUT was placed on the top of a rotating table 1.5 meter above the ground at a 3 meter semi-anechoic chamber. The table was rotated 360 degrees to determine the position of the highest radiation.(above 1GHz)
- c. The height of the equipment or of the substitution antenna shall be 0.8m or 1.5m; the height of the test antenna shall vary between 1 m to 4 m. Both horizontal and vertical polarizations of the antenna are set to make the measurement.
- d. For each suspected emission, the EUT was arranged to its worst case and then the antenna was tuned to heights find the maximum reading (used Bore sight function).
- e. The receiver system was set to peak and average detect function and specified bandwidth with maximum hold mode when the test frequency is above 1 GHz.
- f. The initial step in collecting radiated emission data is a receiver peak detector mode pre-scanning the measurement frequency range. Significant peaks are then marked and then Quasi Peak detector mode re-measured.
- g. All readings are Peak unless otherwise stated QP in column of Note. Peak denotes that the Peak reading compliance with the QP Limits and then QP Mode measurement didn't perform. (below 1 GHz)
- h. All readings are Peak Mode value unless otherwise stated AVG in column of Note. If the Peak Mode Measured value compliance with the Peak Limits and lower than AVG Limits, the EUT shall be deemed to meet both Peak & AVG Limits and then only Peak Mode was measured, but AVG Mode didn't perform. (above 1 GHz)
- i. For the actual test configuration, please refer to the related Item –EUT Test Photos.

## 4.3 DEVIATION FROM TEST STANDARD

No deviation

## 4.4 TEST SETUP

9 kHz to 30 MHz

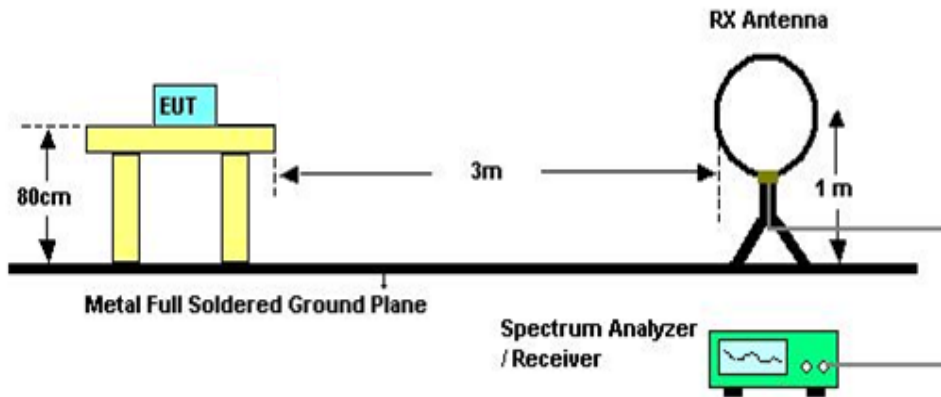

30 MHz to 1 GHz

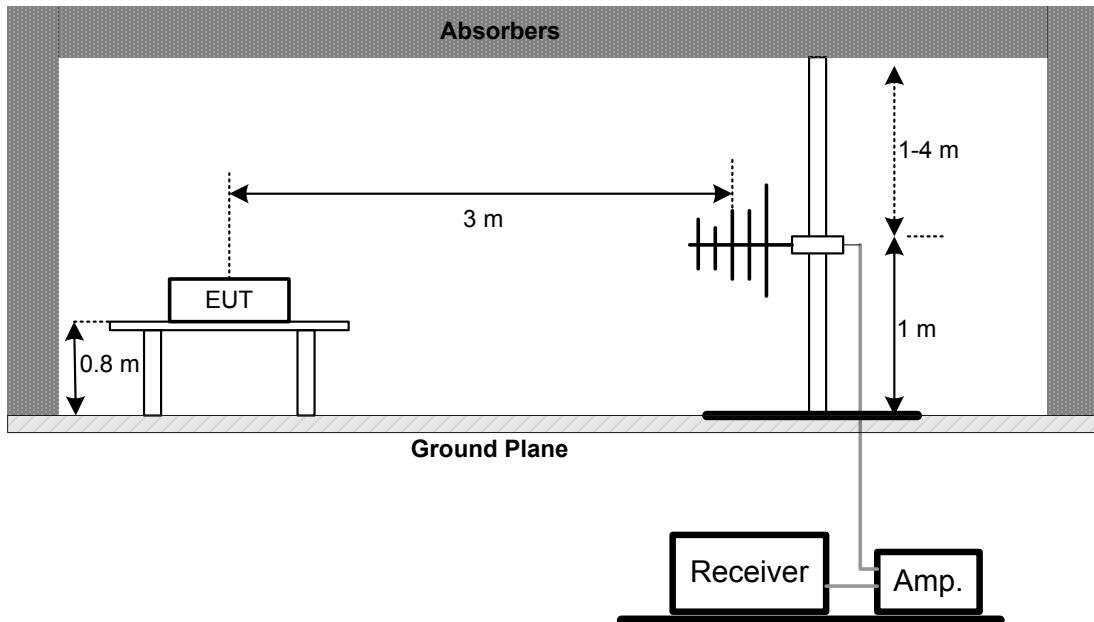



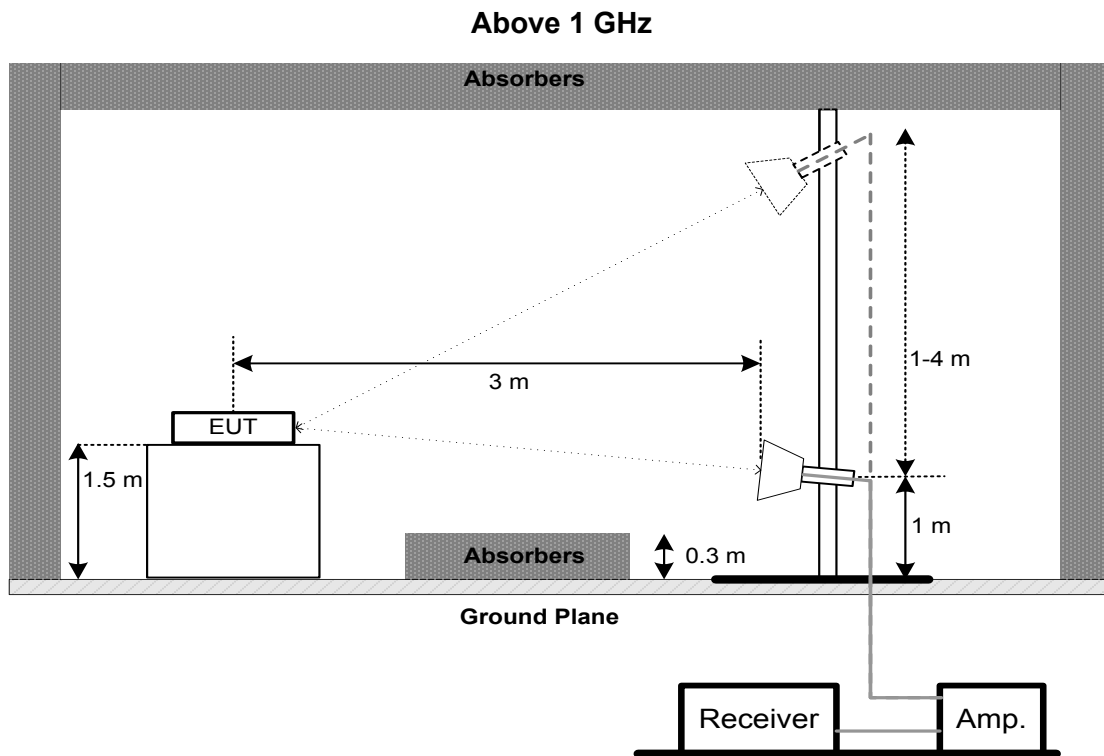

#### 4.5 EUT OPERATION CONDITIONS

The EUT tested system was configured as the statements of 3.5 unless otherwise a special operating condition is specified in the follows during the testing.

#### 4.6 TEST RESULTS - 9 KHZ to 30 MHZ

Please refer to the APPENDIX B

Remark:

- (1) Distance extrapolation factor =  $40 \log (\text{specific distance} / \text{test distance})$  (dB).
- (2) Limit line = specific limits (dBuV) + distance extrapolation factor.

#### 4.7 TEST RESULTS - 30 MHZ TO 1000 MHZ

Please refer to the APPENDIX C.

#### 4.8 TEST RESULTS - ABOVE 1000 MHZ

Please refer to the APPENDIX D.

Remark:

- (1) No limit: This is fundamental signal, the judgment is not applicable.  
For fundamental signal judgment was referred to Peak output test.

## 5. BANDWIDTH TEST

### 5.1 LIMIT

FCC Part15, Subpart E (15.407)			
Section	Test Item	Limit	Frequency Range (MHz)
15.407(a)	26 dB Bandwidth	-	5150-5250
15.407(e)	6 dB Bandwidth	Minimum 500 kHz	5725-5850

### 5.2 TEST PROCEDURE

- a. The EUT was directly connected to the spectrum analyzer and antenna output port as show in the block diagram below
- b. Spectrum Setting:  
For UNII-1:

Spectrum Parameter	Setting
Attenuation	Auto
Span Frequency	> 26 dB Bandwidth
RBW	300 kHz (Bandwidth 20 MHz) 1 MHz (Bandwidth 40 MHz and 80 MHz)
VBW	1 MHz (Bandwidth 20 MHz) 3 MHz (Bandwidth 40 MHz and 80 MHz)
Detector	Peak
Trace	Max Hold
Sweep Time	Auto

For UNII-3:

Spectrum Parameter	Setting
Attenuation	Auto
Span Frequency	6 dB Bandwidth
RBW	100 kHz
VBW	300 kHz
Detector	Peak
Trace	Max Hold
Sweep Time	Auto

- c. Measured the spectrum width with power higher than 26 dB / 6 dB below carrier.

### 5.3 DEVIATION FROM STANDARD

No deviation.

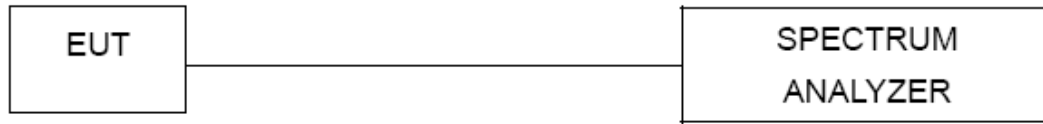
**5.4 TEST SETUP****5.5 EUT OPERATION CONDITIONS**

The EUT was programmed to be in continuously transmitting mode.

**5.6 TEST RESULTS**

Please refer to the APPENDIX E.

**6. MAXIMUM OUTPUT POWER TEST**

**6.1 LIMIT**

FCC Part15, Subpart E (15.407)			
Section	Test Item	Limit	Frequency Range (MHz)
15.407(a)	Maximum Output Power	AP device: 1 Watt (30 dBm) Client device: 250 mW (24 dBm)	5150-5250
		1 Watt (30dBm)	5725-5850

Note:

- a. For an indoor access point operating in the band 5.15-5.25 GHz, the maximum conducted output power over the frequency band of operation shall not exceed 1 W provided the maximum antenna gain does not exceed 6 dBi. In addition, the maximum power spectral density shall not exceed 17 dBm in any 1 megahertz band. If transmitting antennas of directional gain greater than 6 dBi are used, both the maximum conducted output power and the maximum power spectral density shall be reduced by the amount in dB that the directional gain of the antenna exceeds 6 dBi.

**6.2 TEST PROCEDURE**

- a. The EUT was directly connected to the power meter and antenna output port as show in the block diagram below.
- b. Test test was performed in accordance with method of FCC KDB 789033 D02 General UNII Test Procedures New Rules v02r01.

**6.3 DEVIATION FROM STANDARD**

No deviation.

**6.4 TEST SETUP**

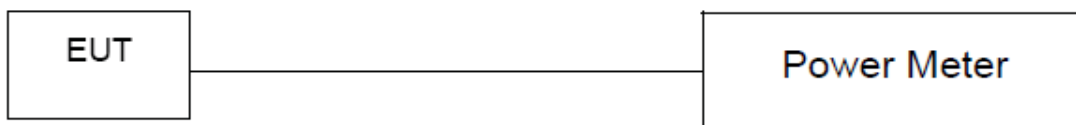

**6.5 EUT OPERATION CONDITIONS**

The EUT was programmed to be in continuously transmitting mode.

**6.6 TEST RESULTS**

Please refer to the APPENDIX F.

## 7. POWER SPECTRAL DENSITY TEST

### 7.1 LIMIT

FCC Part15, Subpart E (15.407)			
Section	Test Item	Limit	Frequency Range (MHz)
15.407(a)	Power Spectral Density	AP device: 17 dBm/MHz Client device: 11 dBm/MHz	5150-5250
		30 dBm/500 kHz	5725-5850

### 7.2 TEST PROCEDURE

a. The EUT was directly connected to the spectrum analyzer and antenna output port as show in the block diagram below.

b. Spectrum Setting:

Spectrum Parameter	Setting
Attenuation	Auto
Span Frequency	Encompass the entire emissions bandwidth (EBW) of the signal
RBW	= 1 MHz.
VBW	≥ 3 MHz.
Detector	RMS
Trace average	100 trace
Sweep Time	Auto

Note:

1. For UNII-3, according to KDB publication 789033 D02 General UNII Test Procedures New Rules v02r01, section II.F.5., it is acceptable to set RBW at 1 MHz and VBW at 3 MHz if the spectrum analyzer does not have 500 kHz RBW.
2. The value measured with RBW=1 MHz is to be added with  $10\log(500\text{ kHz}/1\text{ MHz})$  which is -3 dB. For example, if the measured value is +10dBm using RBW=1 MHz (that is +10 dBm/MHz), then the converted value will be +7dBm/500kHz.

### 7.3 DEVIATION FROM STANDARD

No deviation.

**7.4 TEST SETUP****7.5 EUT OPERATION CONDITIONS**

The EUT was programmed to be in continuously transmitting mode.

**7.6 TEST RESULTS**

Please refer to the APPENDIX G.

## 8. FREQUENCY STABILITY MEASUREMENT

### 8.1 LIMIT

FCC Part15, Subpart E (15.407)			
Section	Test Item	Limit	Frequency Range (MHz)
15.407(g)	Frequency Stability	Specified in the user's manual	5150-5250
			5725-5850

### 8.2 TEST PROCEDURE

- a. The EUT was directly connected to the spectrum analyzer and antenna output port as show in the block diagram below.
- b. Spectrum Setting:

Spectrum Parameter	Setting
Attenuation	Auto
Span Frequency	Entire absence of modulation emissions bandwidth
RBW	10 kHz
VBW	10 kHz
Sweep Time	Auto

- c. The test extreme voltage is to change the primary supply voltage from 85 to 115 percent of the nominal value.
- d. User manual temperature is 0°C~40°C.

### 8.3 DEVIATION FROM STANDARD

No deviation.

#### 8.4 TEST SETUP

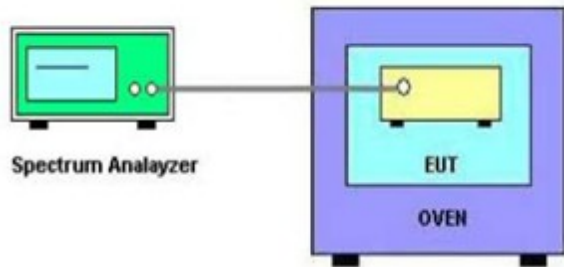

#### 8.5 EUT OPERATION CONDITIONS

The EUT was programmed to be in continuously transmitting mode.

#### 8.6 TEST RESULTS

Please refer to the APPENDIX H.



## 9. MEASUREMENT INSTRUMENTS LIST

AC Power Line Conducted Emissions					
Item	Kind of Equipment	Manufacturer	Type No.	Serial No.	Calibrated until
1	EMI Test Receiver	R&S	ESCI	100382	Mar. 10, 2020
2	LISN	EMCO	3816/2	52765	Mar. 10, 2020
3	TWO-LINE V-NETWORK	R&S	ENV216	101447	May. 19, 2020
4	50Ω Terminator	SHX	TF5-3	15041305	Mar. 10, 2020
5	Measurement Software	Farad	EZ-EMC Ver.NB-03A1-01	N/A	N/A
6	Cable	N/A	RG223	12m	Mar. 12, 2020

Radiated Emissions - 9 kHz to 30 MHz					
Item	Kind of Equipment	Manufacturer	Type No.	Serial No.	Calibrated until
1	Loop Antenna	EM	EM-6876-1	230	Jan. 15, 2020
2	Cable	N/A	RG 213/U	C-102	May 31, 2020
3	EMI Test Receiver	R&S	ESCI	100895	Mar. 10, 2020
4	Measurement Software	Farad	EZ-EMC Ver.NB-03A1-01	N/A	N/A

Radiated Emissions - 30 MHz to 1 GHz					
Item	Kind of Equipment	Manufacturer	Type No.	Serial No.	Calibrated until
1	Antenna	Schwarzbeck	VULB9160	9160-3232	Mar. 09, 2020
2*	Amplifier	HP	8447D	2944A09673	Aug. 11, 2021
3	Receiver	Agilent	N9038A	MY52130039	Aug. 03, 2020
4	Cable	emci	LMR-400(30MHz- 1GHz)(8m+5m)	N/A	May 24, 2020
5	Controller	CT	SC100	N/A	N/A
6	Controller	MF	MF-7802	MF780208416	N/A
7	Measurement Software	Farad	EZ-EMC Ver.NB-03A1-01	N/A	N/A

Radiated Emissions - Above 1 GHz					
Item	Kind of Equipment	Manufacturer	Type No.	Serial No.	Calibrated until
1	Double Ridged Guide Antenna	ETS	3115	75789	Mar. 09, 2020
2	Broad-Band Horn Antenna	Schwarzbeck	BBHA 9170	9170319	Jun. 23, 2020
3	Amplifier	Agilent	8449B	3008A02333	Mar. 10, 2020
4	Microwave Preamplifier With Adaptor	EMC INSTRUMENT	EMC2654045	980039 & HA01	Mar. 10, 2020
5	Receiver	Agilent	N9038A	MY52130039	Aug. 03, 2020
6	Controller	CT	SC100	N/A	N/A
7	Controller	MF	MF-7802	MF780208416	N/A
8	Cable	mitron	B10-01-01-12M	18072744	Jun. 29, 2020
9	Measurement Software	Farad	EZ-EMC Ver.NB-03A1-01	N/A	N/A

<b>Bandwidth &amp; Power Spectral Density</b>					
Item	Kind of Equipment	Manufacturer	Type No.	Serial No.	Calibrated until
1	EXA Spectrum Analyzer	Agilent	N9010A	MY55150209	Mar. 10, 2020

<b>Maximum Output Power</b>					
Item	Kind of Equipment	Manufacturer	Type No.	Serial No.	Calibrated until
1	Peak Power Analyzer	Keysight	8990B	MY51000506	Nov. 26, 2019
2	Wideband power sensor	Keysight	N1923A	MY58310004	Nov. 26, 2019

<b>Frequency Stability</b>					
Item	Kind of Equipment	Manufacturer	Type No.	Serial No.	Calibrated until
1	Spectrum Analyzer	R&S	FSP40	100185	Aug. 03, 2020
2	Precision Oven Tester	Bell	BTH-50C	20170306001	Mar. 10, 2020

Remark: "N/A" denotes no model name, serial no. or calibration specified.

"\*" calibration period of equipment list is three year.

Except \* item, all calibration period of equipment list is one year.

**10. EUT TEST PHOTOS****AC Power Line Conducted Emissions Test Photos**

**Radiated Emissions Test Photos****9 kHz to 30 MHz**

**Radiated Emissions Test Photos**  
**30 MHz to 1 GHz**

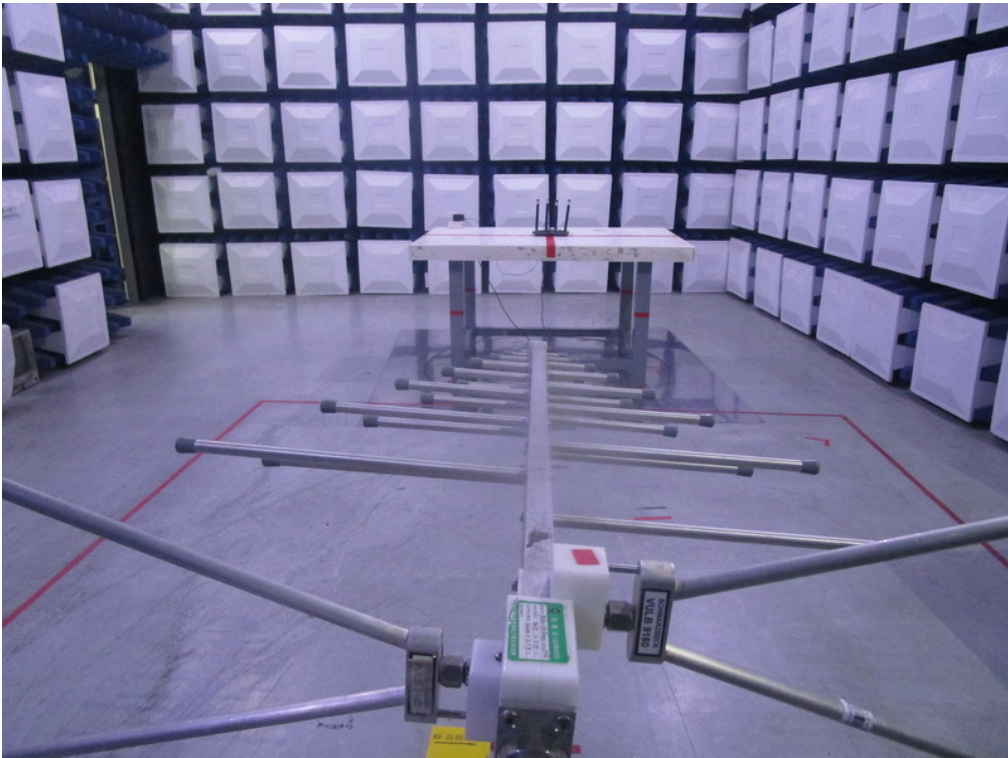
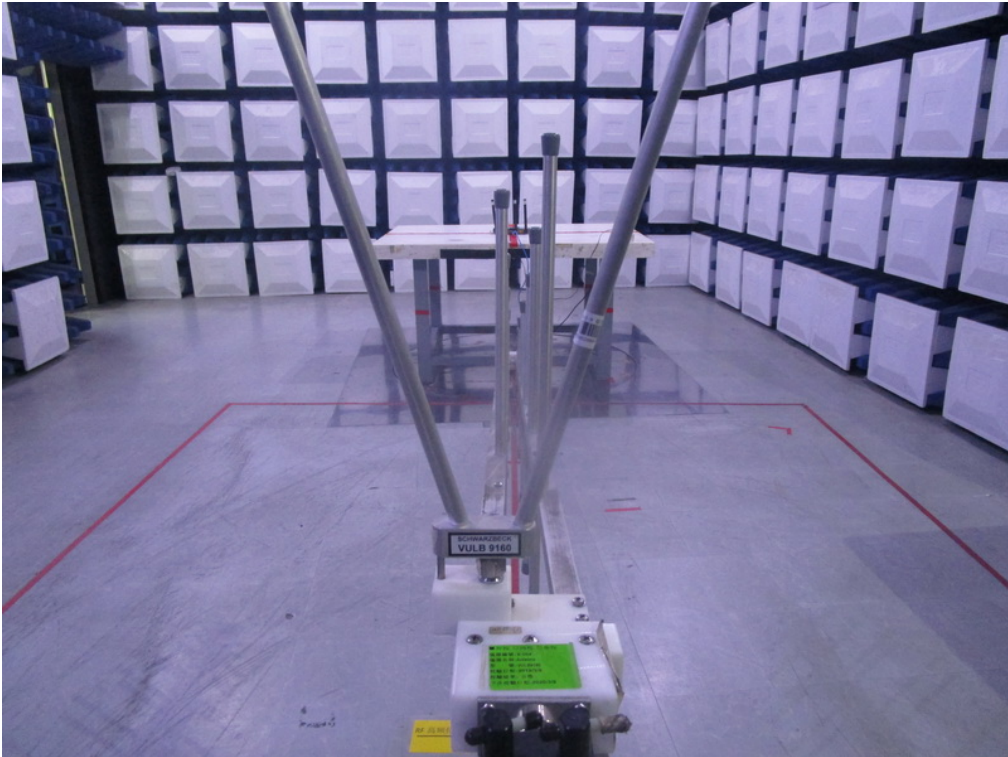

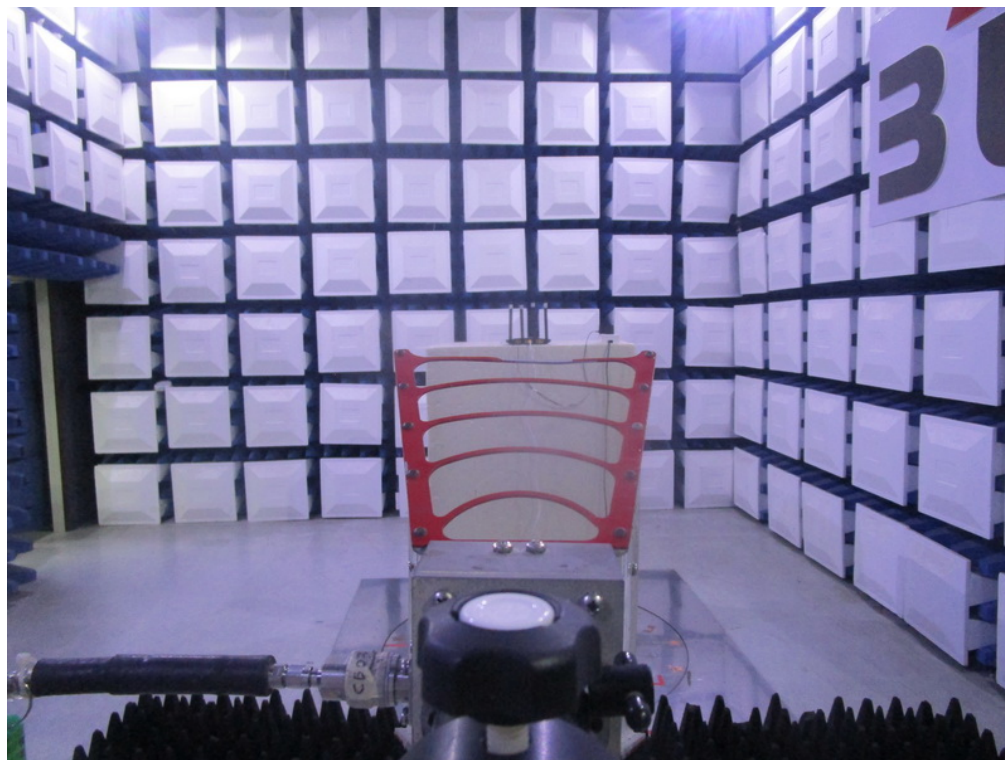
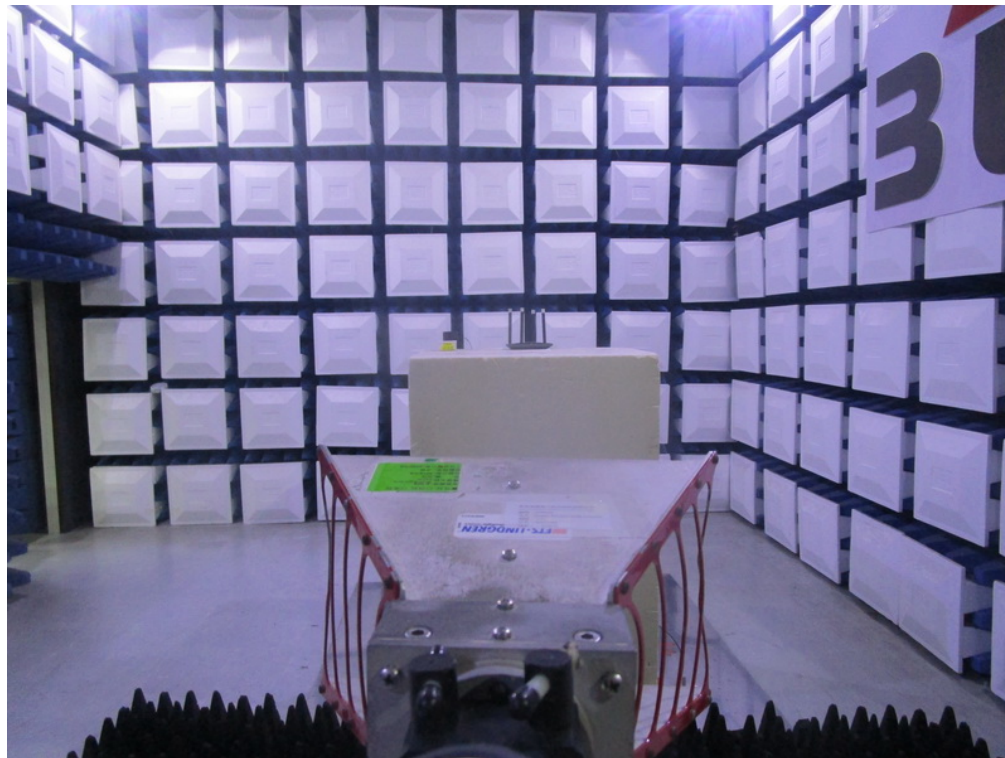
**Radiated Emissions Test Photos****Above 1 GHz**

## **APPENDIX A - AC POWER LINE CONDUCTED EMISSIONS**

Test Mode: TX AC40 Mode Channel 159

### Line

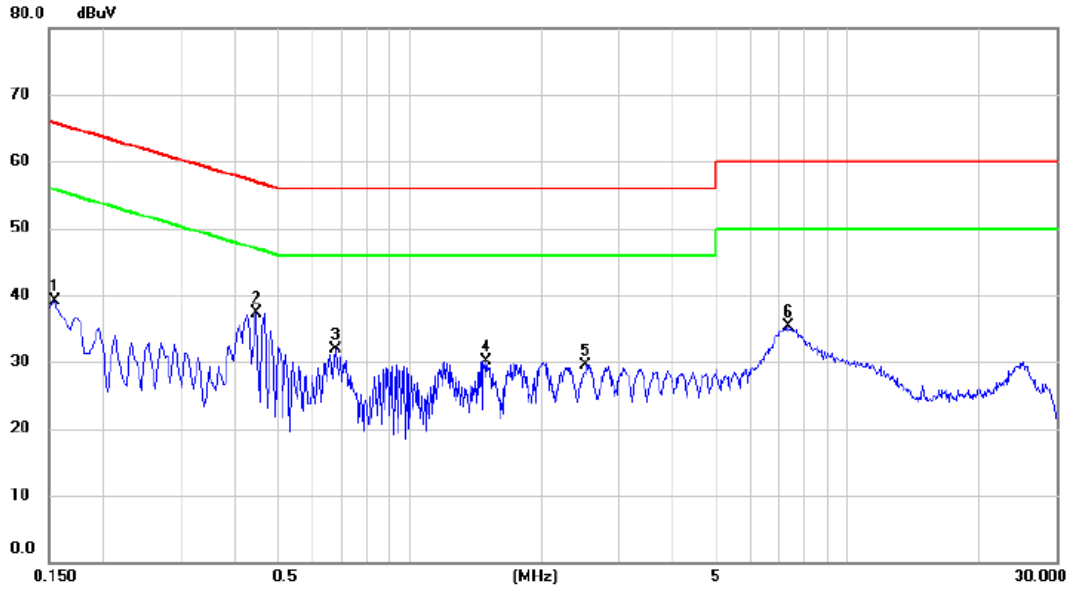

No.	Mk.	Freq. MHz	Reading Level dBuV	Correct Factor dB	Measure- ment dBuV	Limit dBuV	Margin dB	Detector	Comment
1		0.1545	29.32	9.82	39.14	65.75	-26.61	peak	
2	*	0.4470	27.46	9.87	37.33	56.93	-19.60	peak	
3		0.6765	22.01	9.90	31.91	56.00	-24.09	peak	
4		1.4910	20.14	9.95	30.09	56.00	-25.91	peak	
5		2.5305	19.39	10.03	29.42	56.00	-26.58	peak	
6		7.3365	24.94	10.35	35.29	60.00	-24.71	peak	

**REMARKS:**

- (1) Measurement Value = Reading Level + Correct Factor.
- (2) Margin Level = Measurement Value - Limit Value.
- (3) The test result has included the cable loss.



Test Mode: TX AC40 Mode Channel 159

### Neutral

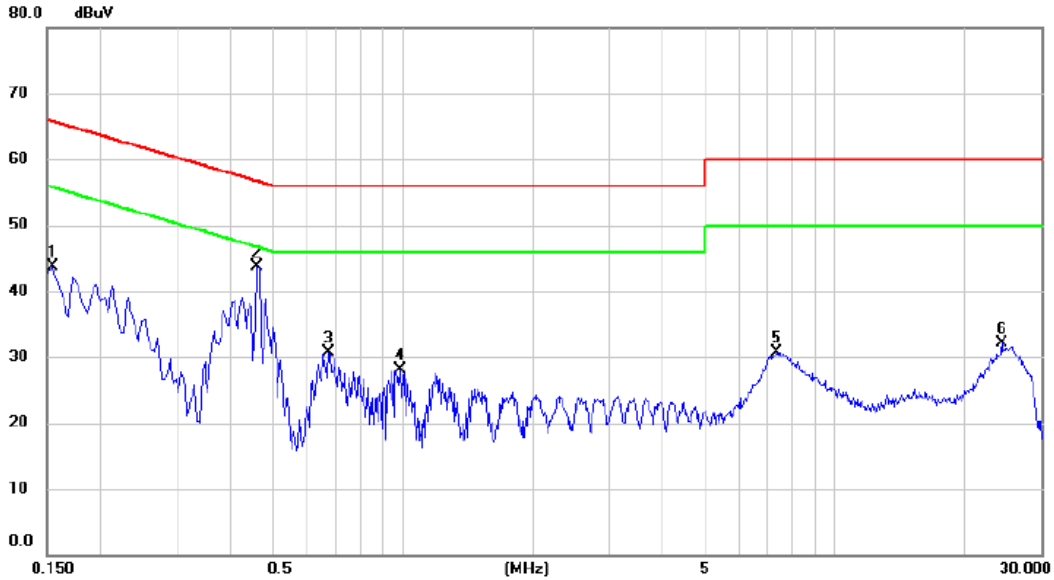

No.	Mk.	Freq. MHz	Reading Level dBuV	Correct Factor dB	Measure- ment dBuV	Limit dBuV	Margin dB	Detector	Comment
1		0.1545	33.80	9.91	43.71	65.75	-22.04	peak	
2	*	0.4605	33.73	10.02	43.75	56.68	-12.93	peak	
3		0.6720	20.65	10.06	30.71	56.00	-25.29	peak	
4		0.9825	17.97	10.12	28.09	56.00	-27.91	peak	
5		7.3230	20.09	10.61	30.70	60.00	-29.30	peak	
6		24.2790	20.63	11.49	32.12	60.00	-27.88	peak	

Note: The test result has included the cable loss.

**REMARKS:**

- (1) Measurement Value = Reading Level + Correct Factor.
- (2) Margin Level = Measurement Value - Limit Value.
- (3) The test result has included the cable loss.

## **APPENDIX B - RADIATED EMISSION - 9 KHZ TO 30 MHZ**

Test Mode: TX AC40 Mode Channel 159

Ant 0°

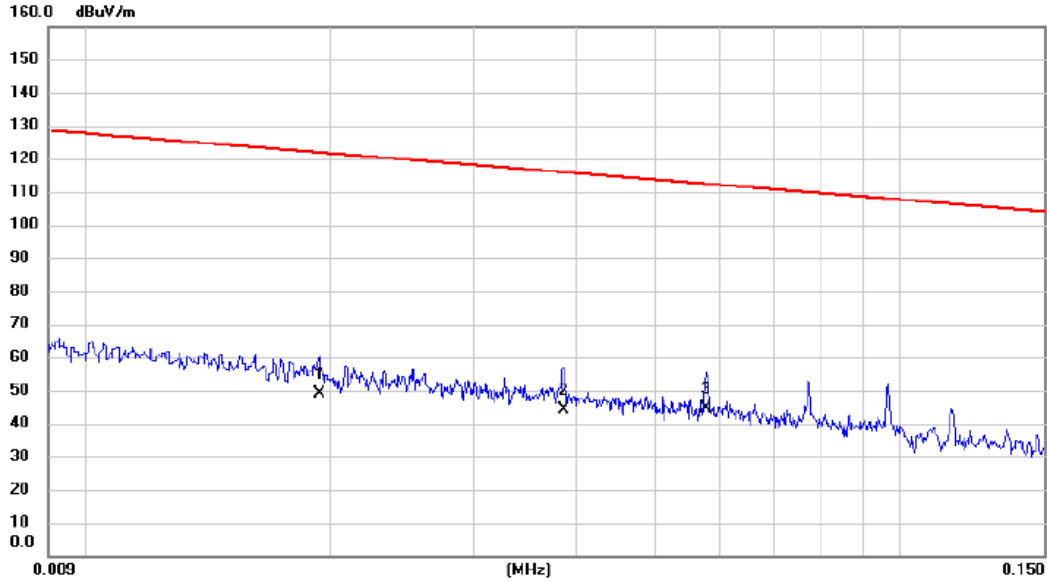

No.	Mk.	Freq. MHz	Reading Level dBuV	Correct Factor dB	Measure- ment dBuV/m	Limit dBuV/m	Margin dB	Detector	Comment
1		0.0194	35.20	14.00	49.20	121.85	-72.65	AVG	
2		0.0387	30.40	13.89	44.29	115.85	-71.56	AVG	
3	*	0.0578	30.80	13.81	44.61	112.37	-67.76	AVG	

REMARKS:

- (1) Measurement Value = Reading Level + Correct Factor.
- (2) Margin Level = Measurement Value - Limit Value.

Test Mode: TX AC40 Mode Channel 159

Ant 0°

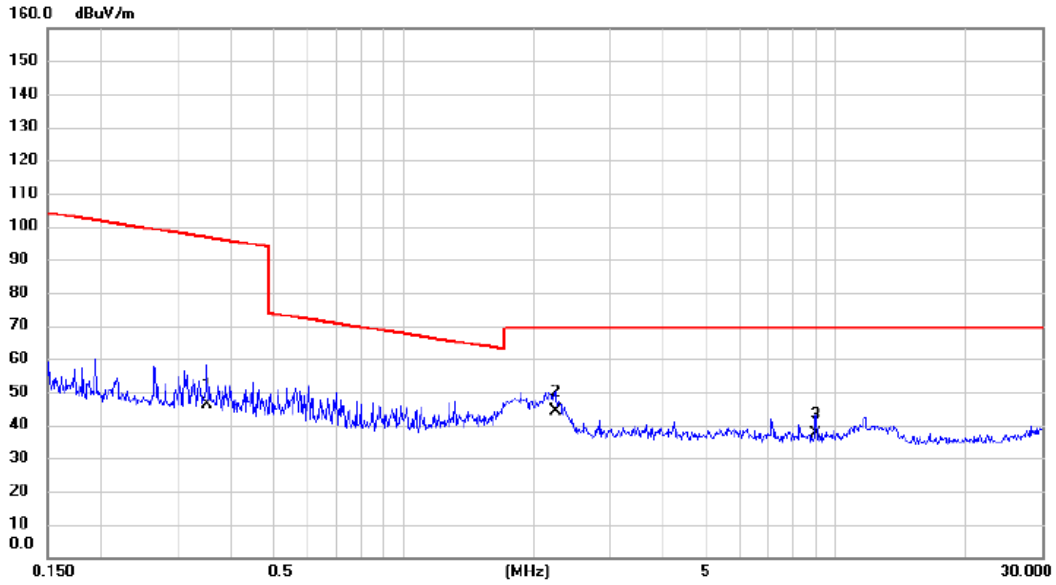

No.	Mk.	Freq. MHz	Reading Level dBuV	Correct Factor dB	Measure- ment dBuV/m	Limit dBuV/m	Margin dB	Detector	Comment
1		0.3502	32.90	13.42	46.32	96.72	-50.40	AVG	
2	*	2.2486	32.60	11.67	44.27	69.54	-25.27	QP	
3		8.9637	25.80	11.47	37.27	69.54	-32.27	QP	

REMARKS:

- (1) Measurement Value = Reading Level + Correct Factor.
- (2) Margin Level = Measurement Value - Limit Value.

Test Mode: TX AC40 Mode Channel 159

**Ant 90°**

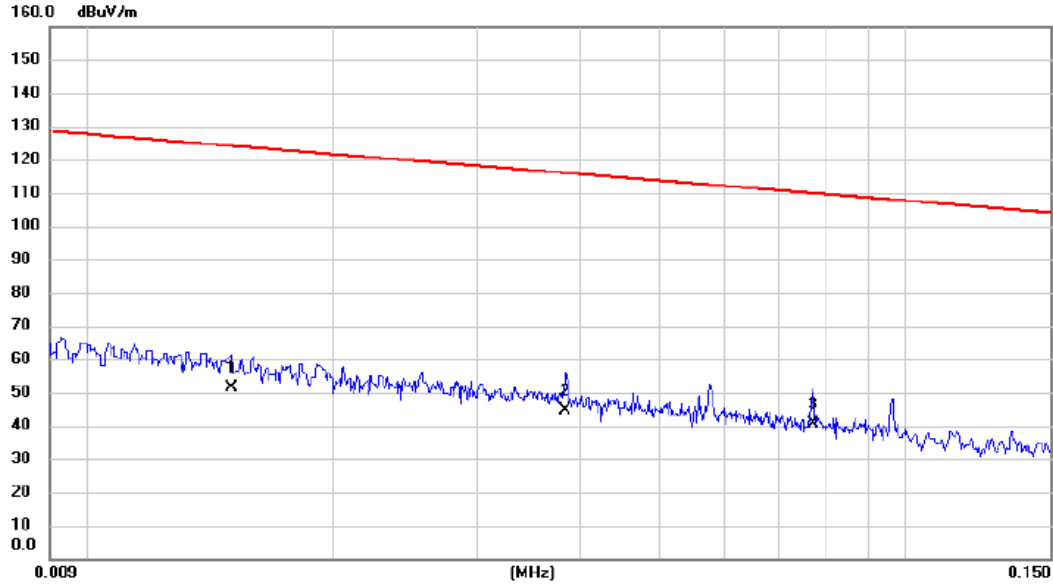

No.	Mk.	Freq. MHz	Reading Level dBuV	Correct Factor dB	Measure- ment dBuV/m	Limit dBuV/m	Margin dB	Detector	Comment
1		0.0150	35.90	15.32	51.22	124.08	-72.86	AVG	
2		0.0384	30.70	13.89	44.59	115.92	-71.33	AVG	
3	*	0.0770	27.10	13.53	40.63	109.88	-69.25	AVG	

**REMARKS:**

- (1) Measurement Value = Reading Level + Correct Factor.
- (2) Margin Level = Measurement Value - Limit Value.

Test Mode: TX AC40 Mode Channel 159

**Ant 90°**

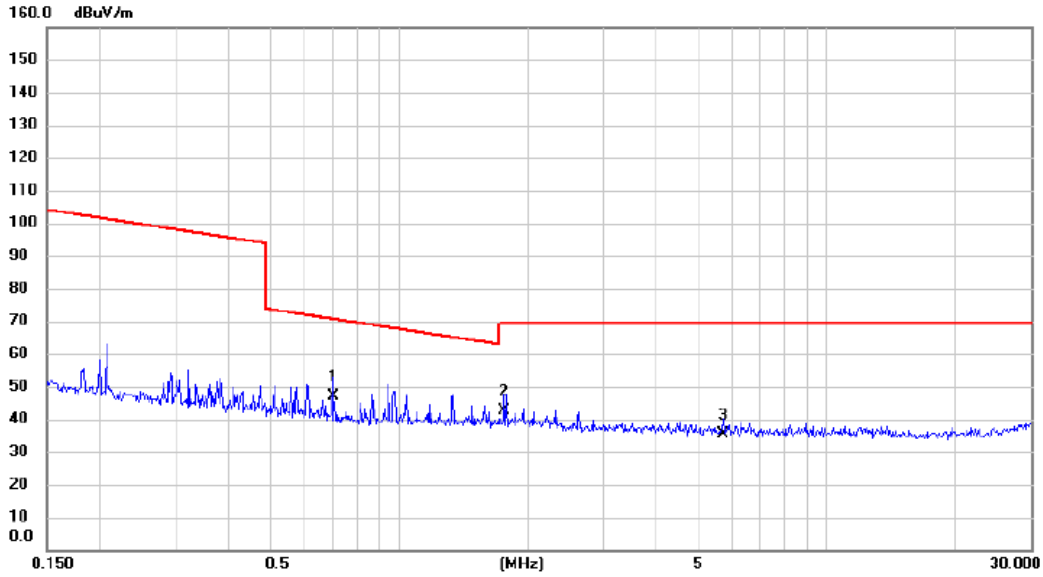

No.	Mk.	Freq. MHz	Reading Level dBuV	Correct Factor dB	Measure- ment dBuV/m	Limit dBuV/m	Margin dB	Detector	Comment
1	*	0.7010	34.20	12.68	46.88	70.69	-23.81	QP	
2		1.7623	30.80	11.98	42.78	69.54	-26.76	QP	
3		5.7437	24.50	10.97	35.47	69.54	-34.07	QP	

**REMARKS:**

- (1) Measurement Value = Reading Level + Correct Factor.
- (2) Margin Level = Measurement Value - Limit Value.

## **APPENDIX C - RADIATED EMISSION - 30 MHZ TO 1 GHZ**

Test Mode: TX AC40 Mode Channel 159

### Vertical

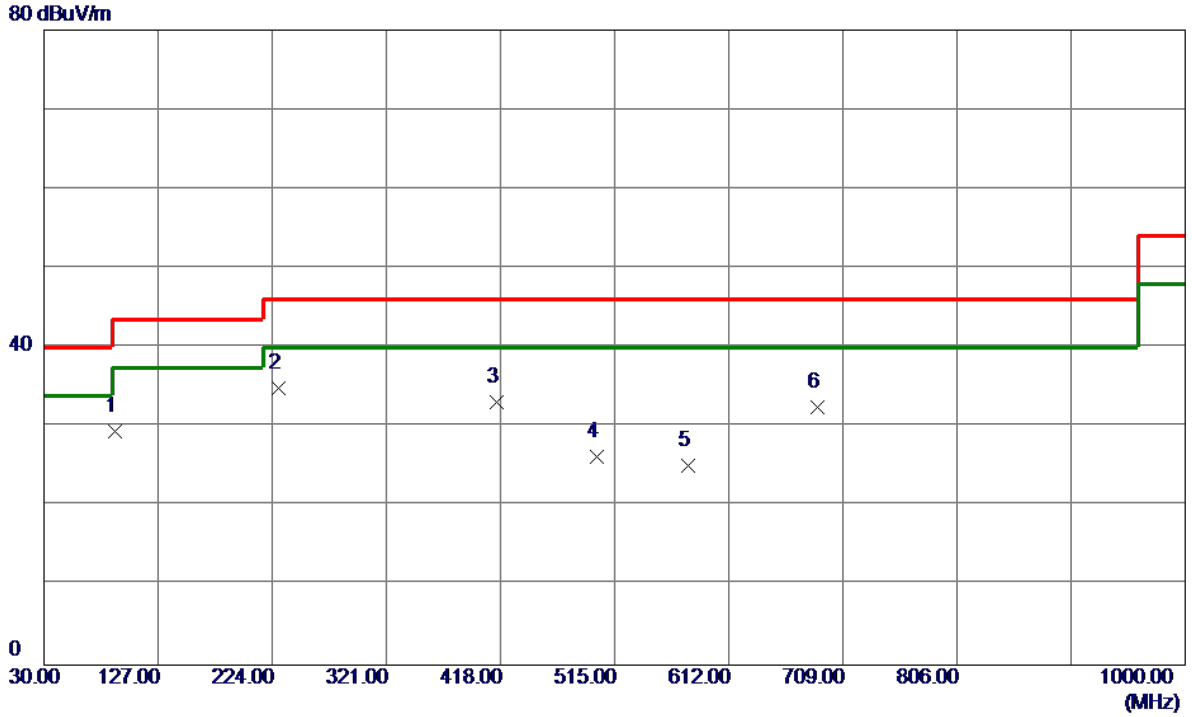

No.	Freq. MHz	Reading Level dBuV/m	Correct Factor dB	Measure ment dBuV/m	Limit dBuV/m	Margin dB	Detector	Comment
1	90.6250	45.39	-15.96	29.43	43.50	-14.07	Peak	
2 *	229.8200	49.10	-14.28	34.82	46.00	-11.18	Peak	
3	415.0900	42.16	-9.05	33.11	46.00	-12.89	Peak	
4	499.9650	33.90	-7.68	26.22	46.00	-19.78	Peak	
5	577.5650	31.49	-6.40	25.09	46.00	-20.91	Peak	
6	687.6599	36.60	-4.17	32.43	46.00	-13.57	Peak	

**REMARKS:**

- (1) Measurement Value = Reading Level + Correct Factor.
- (2) Margin Level = Measurement Value - Limit Value.



Test Mode: TX AC40 Mode Channel 159

### Horizontal

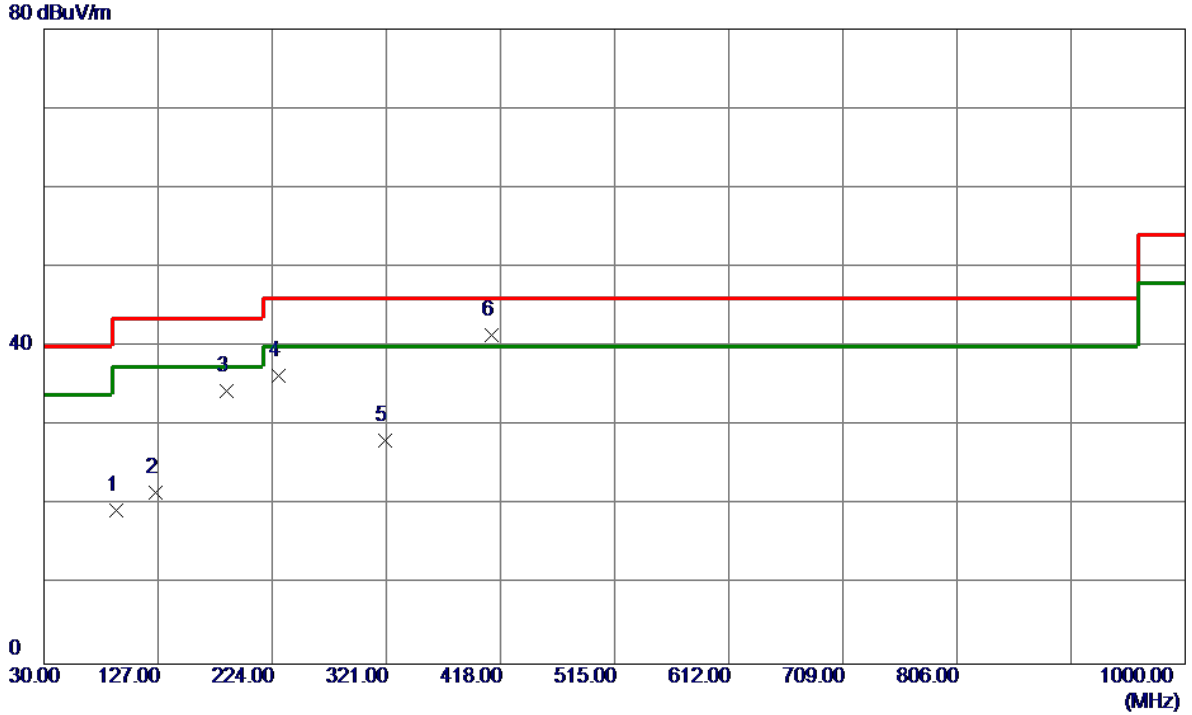

No.	Freq. MHz	Reading Level dBuV/m	Correct Factor dB	Measure ment dBuV/m	Limit dBuV/m	Margin dB	Detector	Comment
1	91.1100	35.34	-15.92	19.42	43.50	-24.08	Peak	
2	125.0600	34.71	-13.04	21.67	43.50	-21.83	Peak	
3	184.7150	48.18	-13.76	34.42	43.50	-9.08	Peak	
4	229.8200	50.58	-14.28	36.30	46.00	-9.70	Peak	
5	320.0300	39.27	-11.16	28.11	46.00	-17.89	Peak	
6 *	410.2400	50.66	-9.18	41.48	46.00	-4.52	Peak	

**REMARKS:**

- (1) Measurement Value = Reading Level + Correct Factor.
- (2) Margin Level = Measurement Value - Limit Value.

## **APPENDIX D - RADIATED EMISSION - ABOVE 1000 MHZ**

## Non Beamforming

Orthogonal Axis	X
Test Mode	UNII-1_TX A Mode 5180 MHz

### Vertical

130 dBuV/m

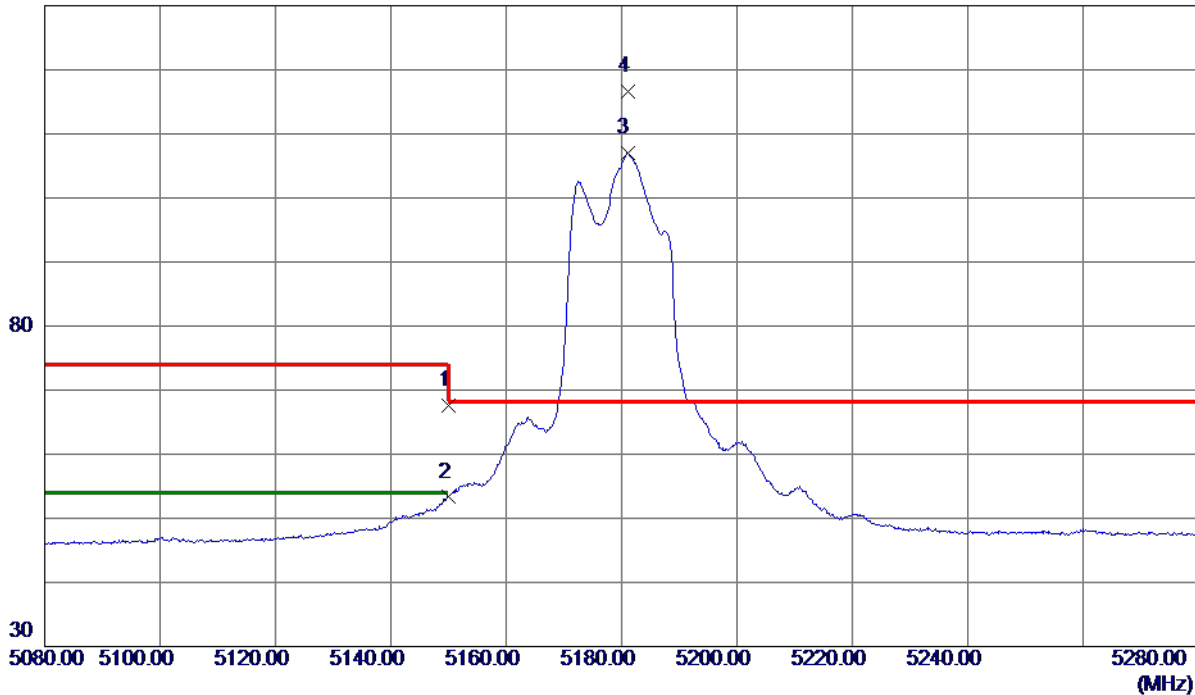

No.	Freq. MHz	Reading Level dBuV/m	Correct Factor dB	Measure ment dBuV/m	Limit dBuV/m	Margin dB	Detector	Comment
1	5150.0000	51.85	15.68	67.53	74.00	-6.47	Peak	
2	5150.0000	37.62	15.68	53.30	54.00	-0.70	AVG	
3	5181.0000	91.24	15.70	106.94	999.00	-892.06	AVG	No Limit
4 *	5181.1000	100.90	15.70	116.60	68.30	48.30	Peak	No Limit

#### REMARKS:

- (1) Measurement Value = Reading Level + Correct Factor.
- (2) Margin Level = Measurement Value - Limit Value.

Orthogonal Axis	X
Test Mode	UNII-1_TX A Mode 5180 MHz

### Vertical

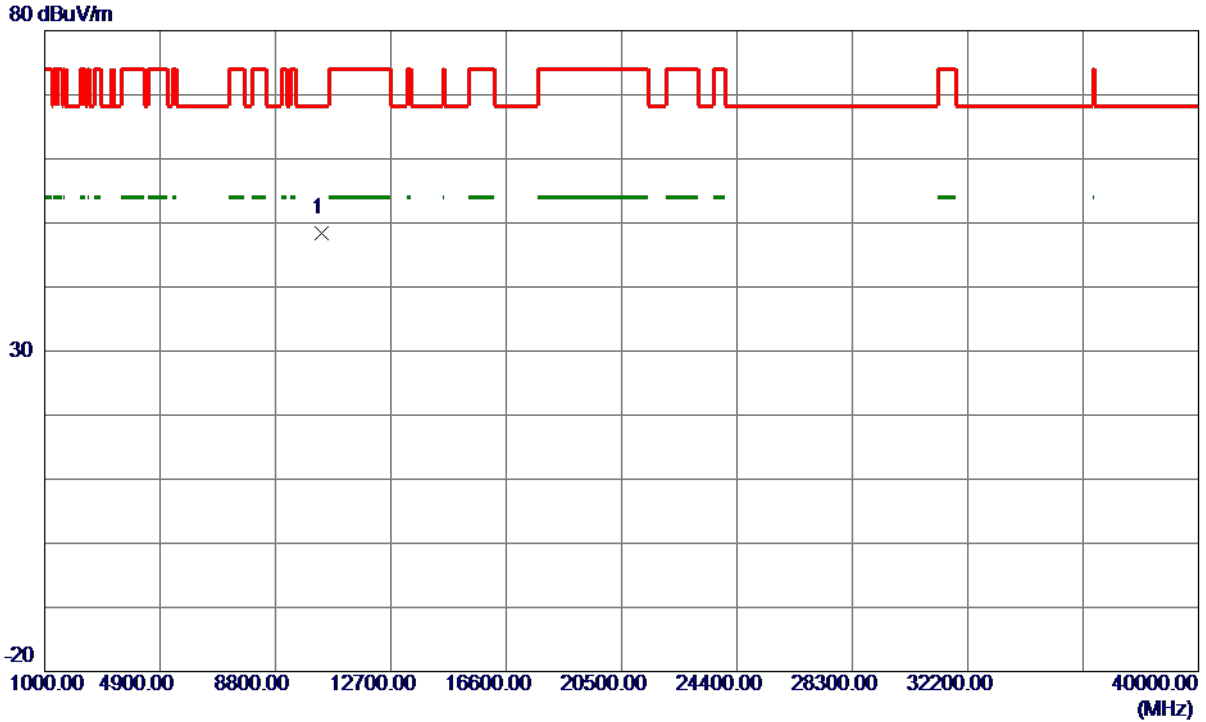

No.	Freq. MHz	Reading Level dBuV/m	Correct Factor dB	Measure ment dBuV/m	Limit dBuV/m	Margin dB	Detector	Comment
1 *	10361.4400	39.42	8.90	48.32	68.30	-19.98	Peak	

**REMARKS:**

- (1) Measurement Value = Reading Level + Correct Factor.
- (2) Margin Level = Measurement Value - Limit Value.

Orthogonal Axis	X
Test Mode	UNII-1_TX A Mode 5180 MHz

### Horizontal

130 dBuV/m

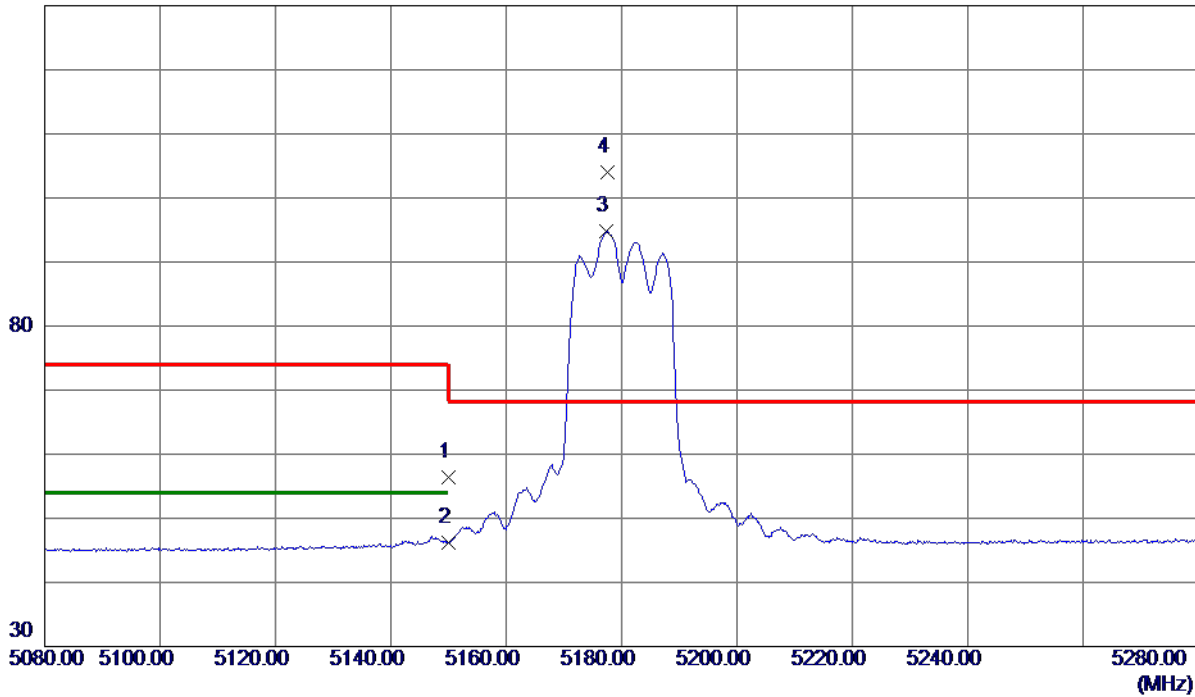

No.	Freq. MHz	Reading Level dBuV/m	Correct Factor dB	Measure ment dBuV/m	Limit dBuV/m	Margin dB	Detector	Comment
1	5150.0000	40.73	15.68	56.41	74.00	-17.59	Peak	
2	5150.0000	30.53	15.68	46.21	54.00	-7.79	AVG	
3	5177.4000	79.05	15.70	94.75	999.00	-904.25	AVG	No Limit
4 *	5177.5000	88.20	15.70	103.90	68.30	35.60	Peak	No Limit

**REMARKS:**

- (1) Measurement Value = Reading Level + Correct Factor.
- (2) Margin Level = Measurement Value - Limit Value.

Orthogonal Axis	X
Test Mode	UNII-1_TX A Mode 5180 MHz

### Horizontal

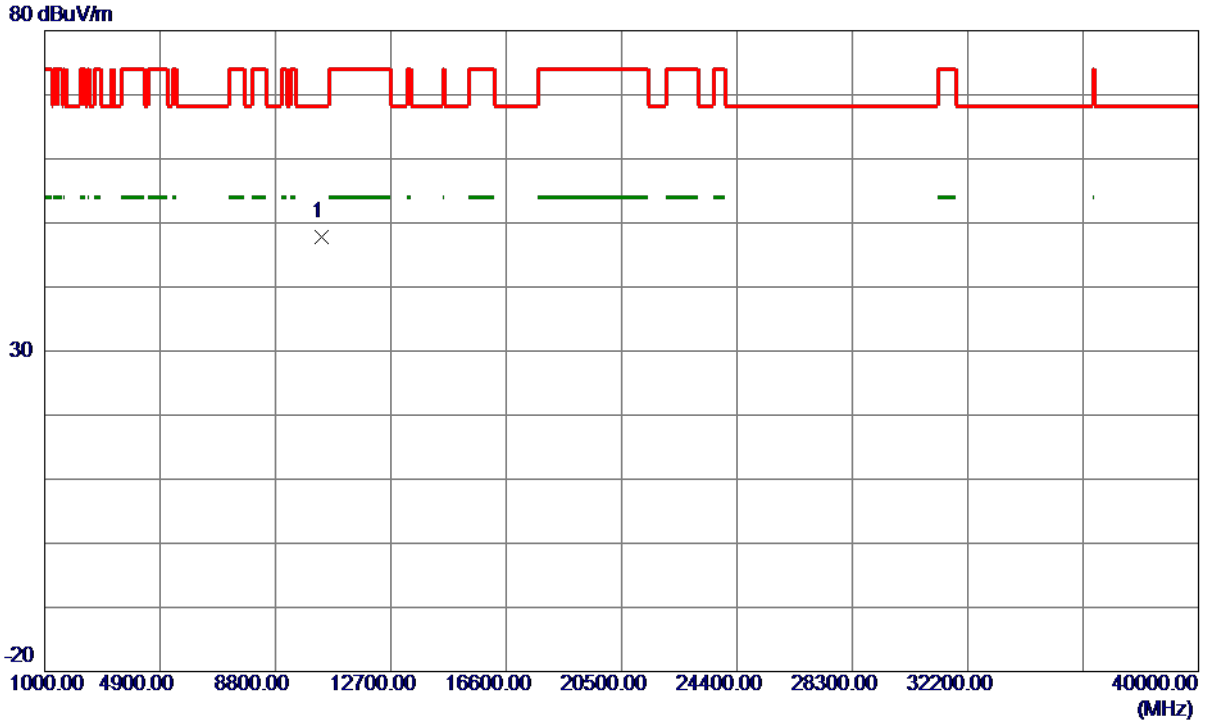

No.	Freq. MHz	Reading Level dBuV/m	Correct Factor dB	Measure ment dBuV/m	Limit dBuV/m	Margin dB	Detector	Comment
1 *	10363.0199	38.92	8.90	47.82	68.30	-20.48	Peak	

**REMARKS:**

- (1) Measurement Value = Reading Level + Correct Factor.
- (2) Margin Level = Measurement Value - Limit Value.

Orthogonal Axis	X
Test Mode	UNII-1_TX A Mode 5200 MHz

### Vertical

130 dBuV/m

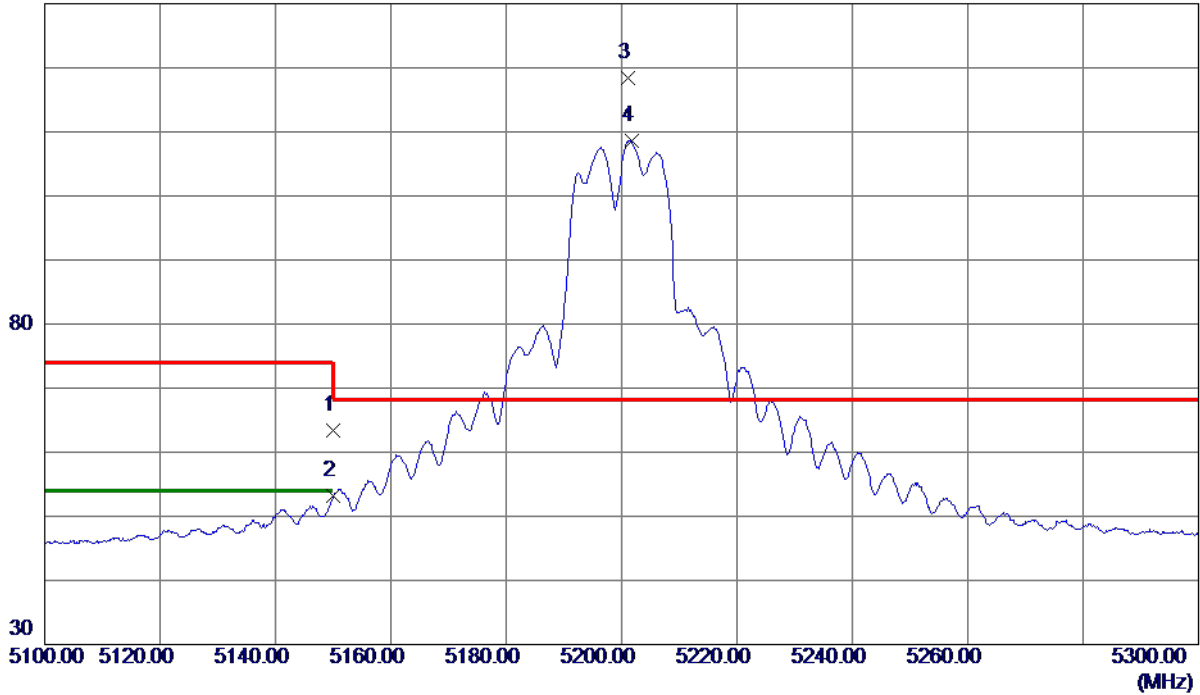

No.	Freq. MHz	Reading Level dBuV/m	Correct Factor dB	Measure ment dBuV/m	Limit dBuV/m	Margin dB	Detector	Comment
1	5150.0000	47.81	15.68	63.49	74.00	-10.51	Peak	
2	5150.0000	37.46	15.68	53.14	54.00	-0.86	AVG	
3 *	5201.2000	102.60	15.71	118.31	68.30	50.01	Peak	No Limit
4	5201.7000	92.90	15.71	108.61	999.00	-890.39	AVG	No Limit

**REMARKS:**

- (1) Measurement Value = Reading Level + Correct Factor.
- (2) Margin Level = Measurement Value - Limit Value.

Orthogonal Axis	X
Test Mode	UNII-1_TX A Mode 5200 MHz

### Vertical

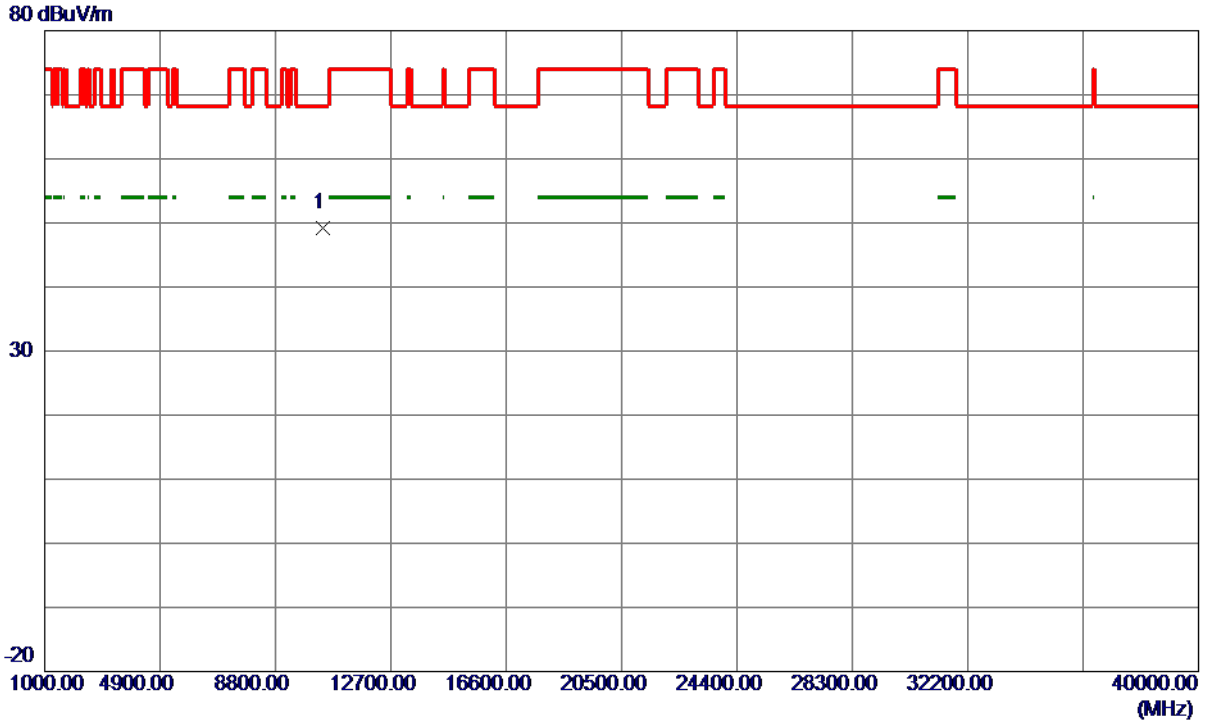

No.	Freq. MHz	Reading Level dBuV/m	Correct Factor dB	Measure ment dBuV/m	Limit dBuV/m	Margin dB	Detector	Comment
1 *	10403.1200	40.21	8.98	49.19	68.30	-19.11	Peak	

**REMARKS:**

- (1) Measurement Value = Reading Level + Correct Factor.
- (2) Margin Level = Measurement Value - Limit Value.



Orthogonal Axis	X
Test Mode	UNII-1_TX A Mode 5200 MHz

### Horizontal

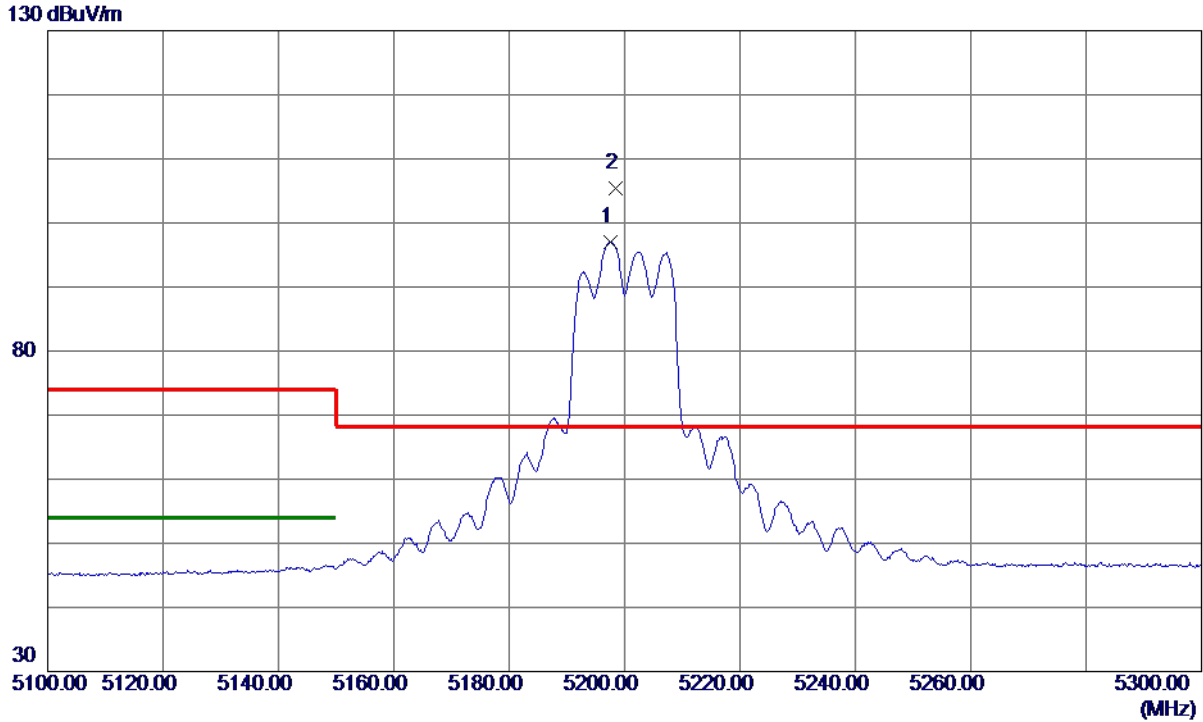

No.	Freq. MHz	Reading Level dBuV/m	Correct Factor dB	Measure ment dBuV/m	Limit dBuV/m	Margin dB	Detector	Comment
1	5197.5000	81.37	15.71	97.08	999.00	-901.92	AVG	No Limit
2 *	5198.4000	89.70	15.71	105.41	68.30	37.11	Peak	No Limit

**REMARKS:**

- (1) Measurement Value = Reading Level + Correct Factor.
- (2) Margin Level = Measurement Value - Limit Value.

Orthogonal Axis	X
Test Mode	UNII-1_TX A Mode 5200 MHz

### Horizontal

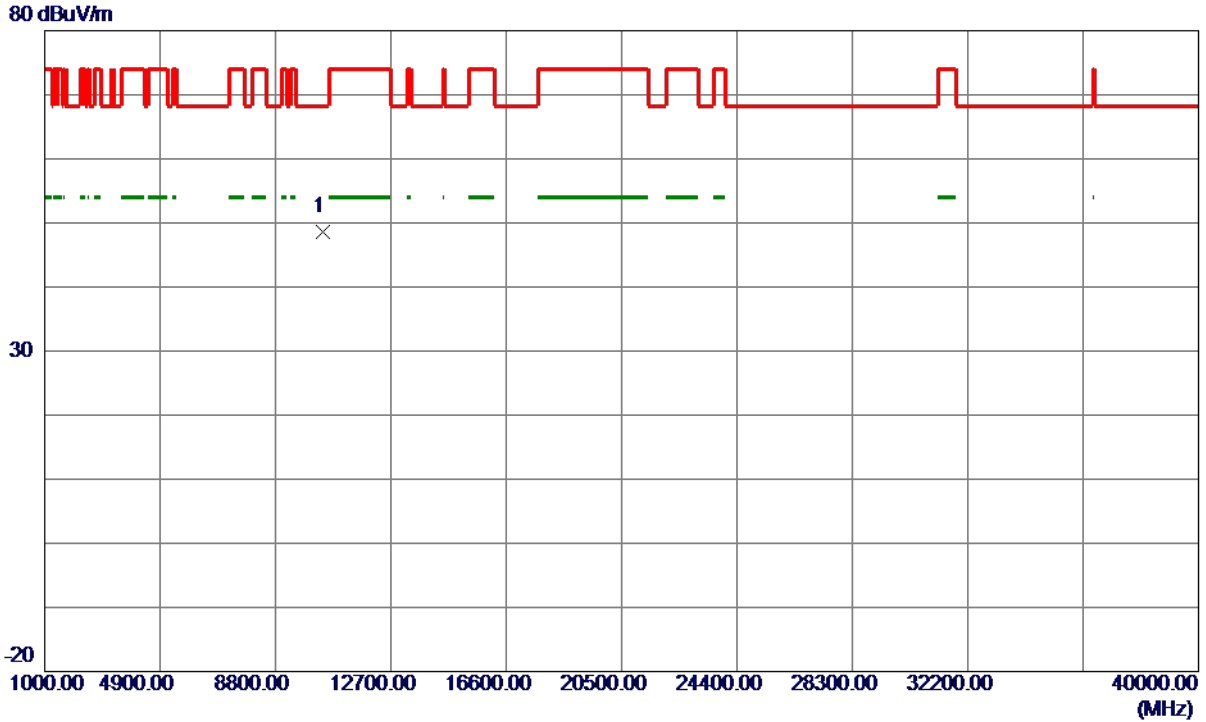

No.	Freq. MHz	Reading Level dBuV/m	Correct Factor dB	Measure ment dBuV/m	Limit dBuV/m	Margin dB	Detector	Comment
1 *	10401.9400	39.66	8.98	48.64	68.30	-19.66	Peak	

**REMARKS:**

- (1) Measurement Value = Reading Level + Correct Factor.
- (2) Margin Level = Measurement Value - Limit Value.

Orthogonal Axis	X
Test Mode	UNII-1_TX A Mode 5240 MHz

### Vertical

130 dBuV/m



No.	Freq. MHz	Reading Level dBuV/m	Correct Factor dB	Measure ment dBuV/m	Limit dBuV/m	Margin dB	Detector	Comment
1 *	5243.2000	102.94	15.73	118.67	68.30	50.37	Peak	No Limit
2	5243.3000	94.26	15.73	109.99	999.00	-889.01	AVG	No Limit

**REMARKS:**

- (1) Measurement Value = Reading Level + Correct Factor.
- (2) Margin Level = Measurement Value - Limit Value.

Orthogonal Axis	X
Test Mode	UNII-1_TX A Mode 5240 MHz

### Vertical

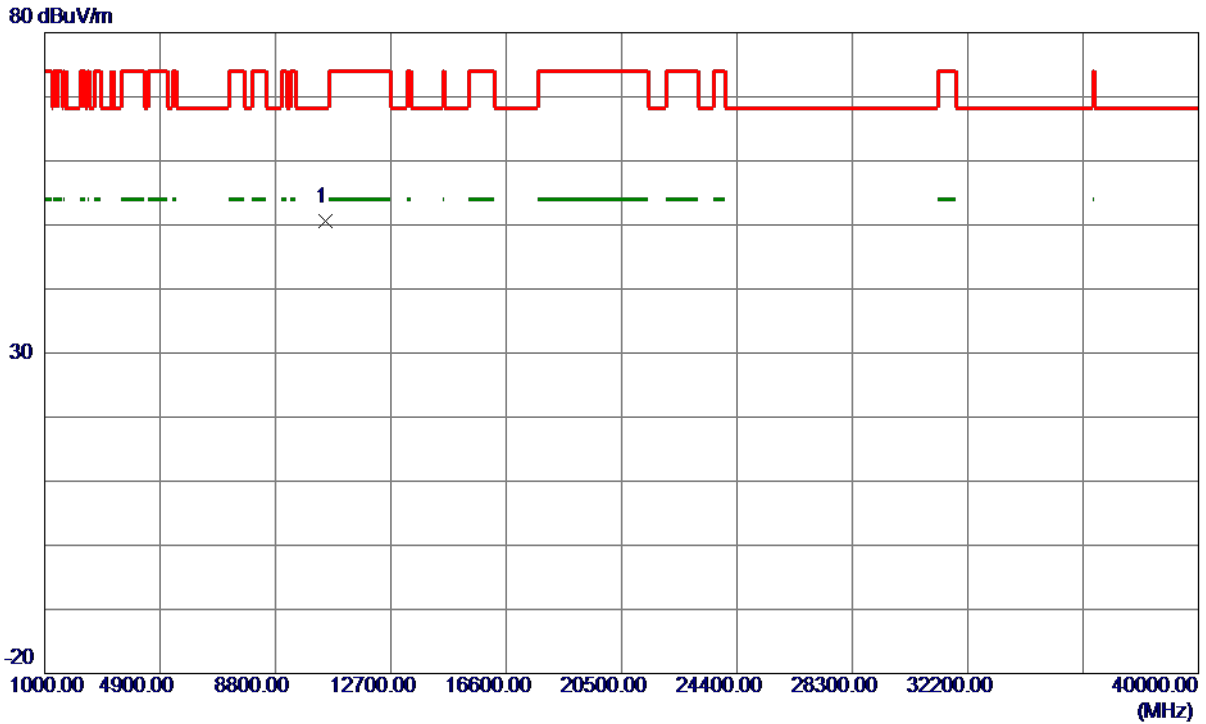

No.	Freq. MHz	Reading Level dBuV/m	Correct Factor dB	Measure ment dBuV/m	Limit dBuV/m	Margin dB	Detector	Comment
1 *	10480.8200	41.38	9.12	50.50	68.30	-17.80	Peak	

**REMARKS:**

- (1) Measurement Value = Reading Level + Correct Factor.
- (2) Margin Level = Measurement Value - Limit Value.

Orthogonal Axis	X
Test Mode	UNII-1_TX A Mode 5240 MHz

### Horizontal

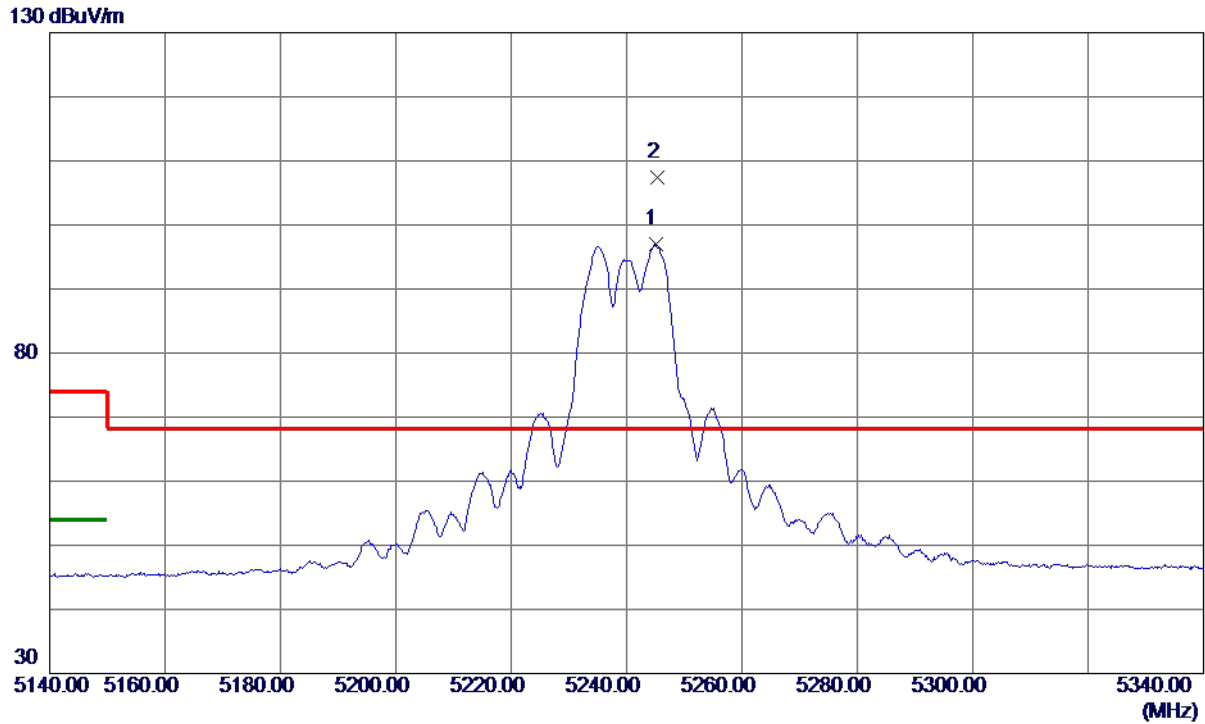

No.	Freq. MHz	Reading Level dBuV/m	Correct Factor dB	Measure ment dBuV/m	Limit dBuV/m	Margin dB	Detector	Comment
1	5245.0000	81.19	15.73	96.92	999.00	-902.08	AVG	No Limit
2 *	5245.4000	91.67	15.73	107.40	68.30	39.10	Peak	No Limit

**REMARKS:**

- (1) Measurement Value = Reading Level + Correct Factor.
- (2) Margin Level = Measurement Value - Limit Value.

Orthogonal Axis	X
Test Mode	UNII-1_TX A Mode 5240 MHz

### Horizontal

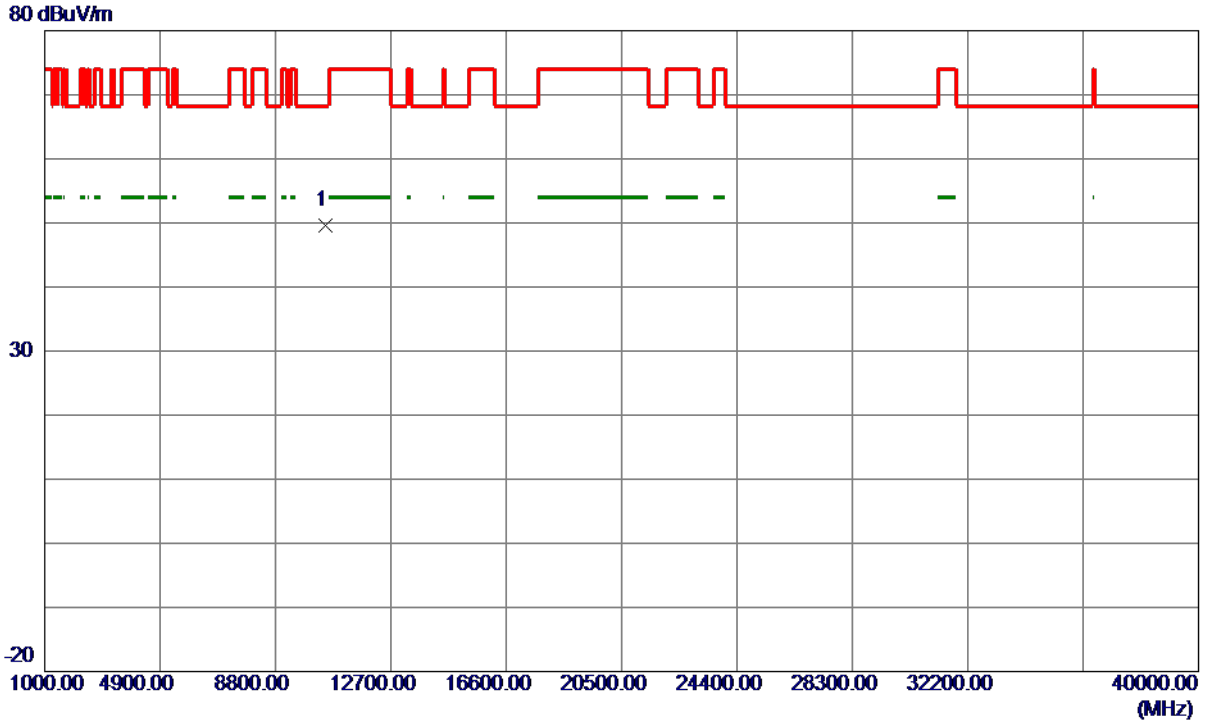

No.	Freq. MHz	Reading Level dBuV/m	Correct Factor dB	Measure ment dBuV/m	Limit dBuV/m	Margin dB	Detector	Comment
1 *	10481.0199	40.39	9.12	49.51	68.30	-18.79	Peak	

**REMARKS:**

- (1) Measurement Value = Reading Level + Correct Factor.
- (2) Margin Level = Measurement Value - Limit Value.

Orthogonal Axis	X
Test Mode	UNII-3_TX A Mode 5745 MHz

### Vertical

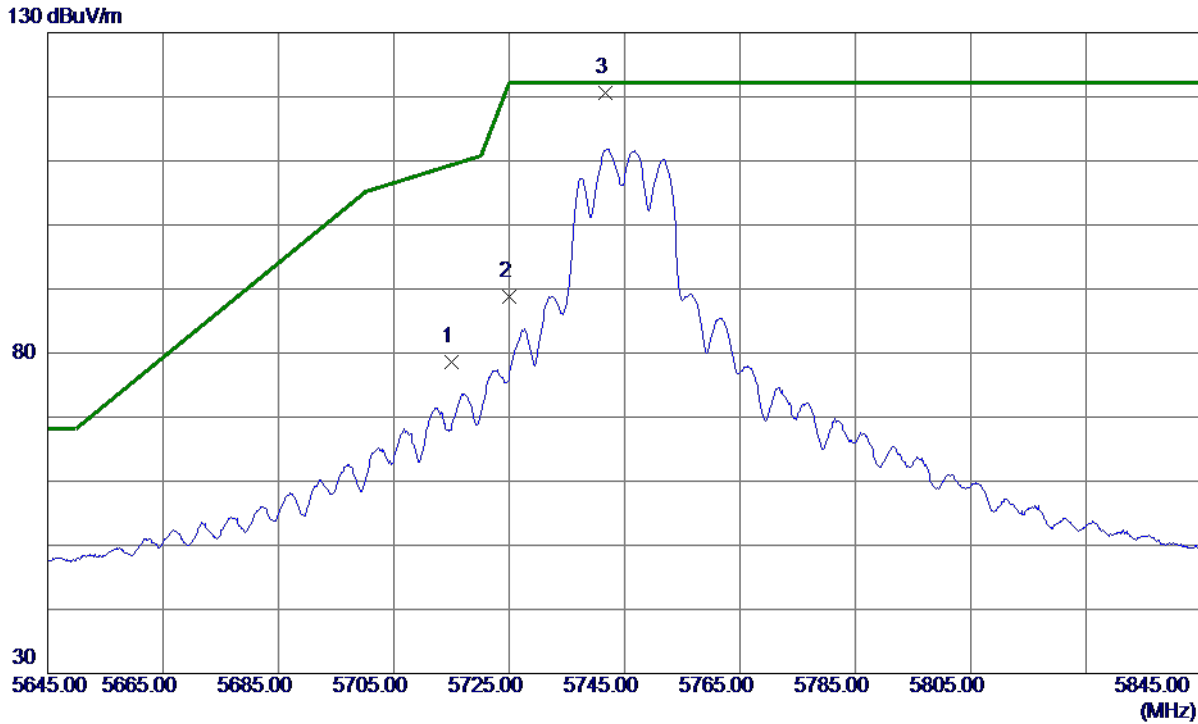

No.	Freq. MHz	Reading Level dBuV/m	Correct Factor dB	Measure ment dBuV/m	Limit dBuV/m	Margin dB	Detector	Comment
1	5715.0000	62.52	15.99	78.51	109.40	-30.89	Peak	
2	5725.0000	72.72	16.00	88.72	122.20	-33.48	Peak	
3 *	5741.6000	104.68	16.01	120.69	122.20	-1.51	Peak	No Limit

**REMARKS:**

- (1) Measurement Value = Reading Level + Correct Factor.
- (2) Margin Level = Measurement Value - Limit Value.

Orthogonal Axis	X
Test Mode	UNII-3_TX A Mode 5745 MHz

### Vertical

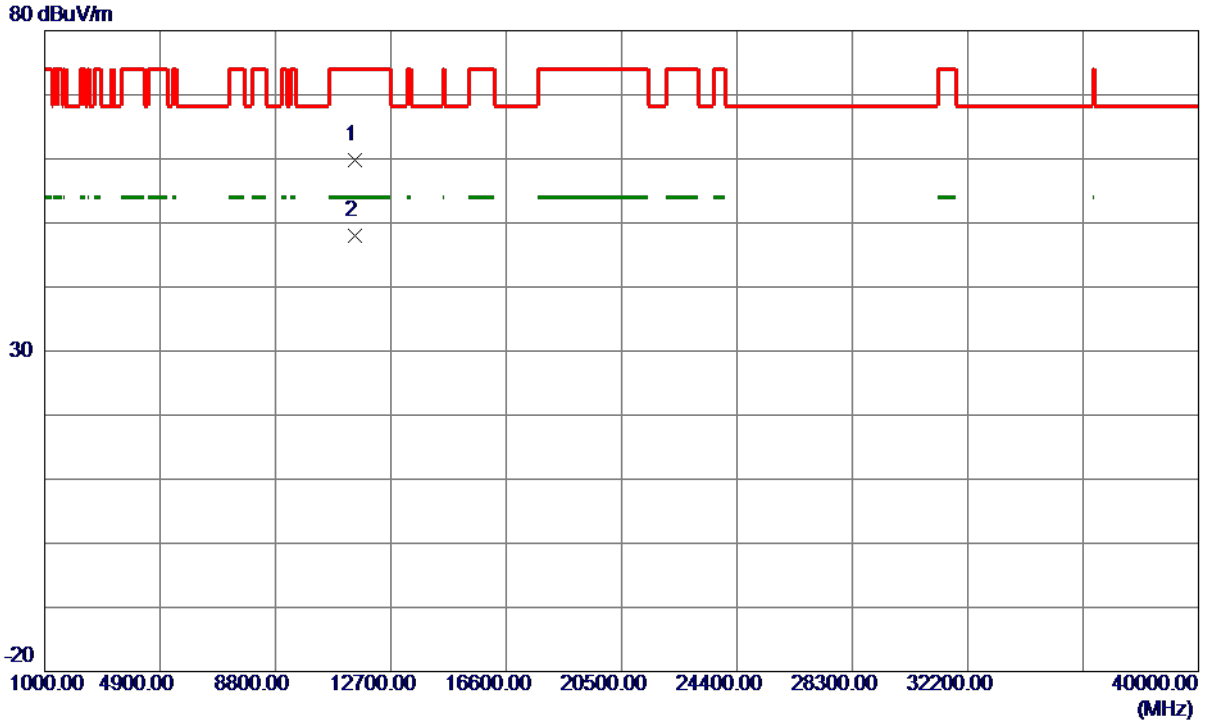

No.	Freq. MHz	Reading Level dBuV/m	Correct Factor dB	Measure ment dBuV/m	Limit dBuV/m	Margin dB	Detector	Comment
1	11487.9800	49.12	10.70	59.82	74.00	-14.18	Peak	
2 *	11488.2400	37.35	10.70	48.05	54.00	-5.95	AVG	

**REMARKS:**

- (1) Measurement Value = Reading Level + Correct Factor.
- (2) Margin Level = Measurement Value - Limit Value.



Orthogonal Axis	X
Test Mode	UNII-3_TX A Mode 5745 MHz

### Horizontal

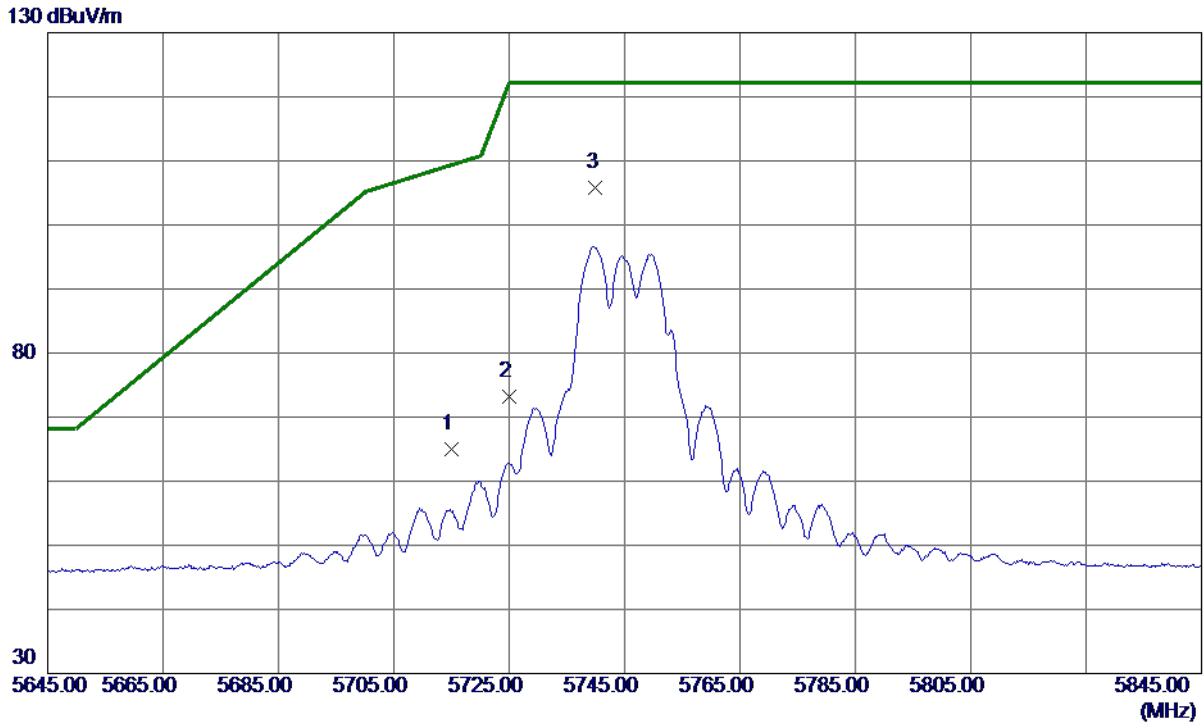

No.	Freq. MHz	Reading Level dBuV/m	Correct Factor dB	Measure ment dBuV/m	Limit dBuV/m	Margin dB	Detector	Comment
1	5715.0000	49.06	15.99	65.05	109.40	-44.35	Peak	
2	5725.0000	57.12	16.00	73.12	122.20	-49.08	Peak	
3 *	5740.0000	89.72	16.01	105.73	122.20	-16.47	Peak	No Limit

**REMARKS:**

- (1) Measurement Value = Reading Level + Correct Factor.
- (2) Margin Level = Measurement Value - Limit Value.

Orthogonal Axis	X
Test Mode	UNII-3_TX A Mode 5745 MHz

### Horizontal

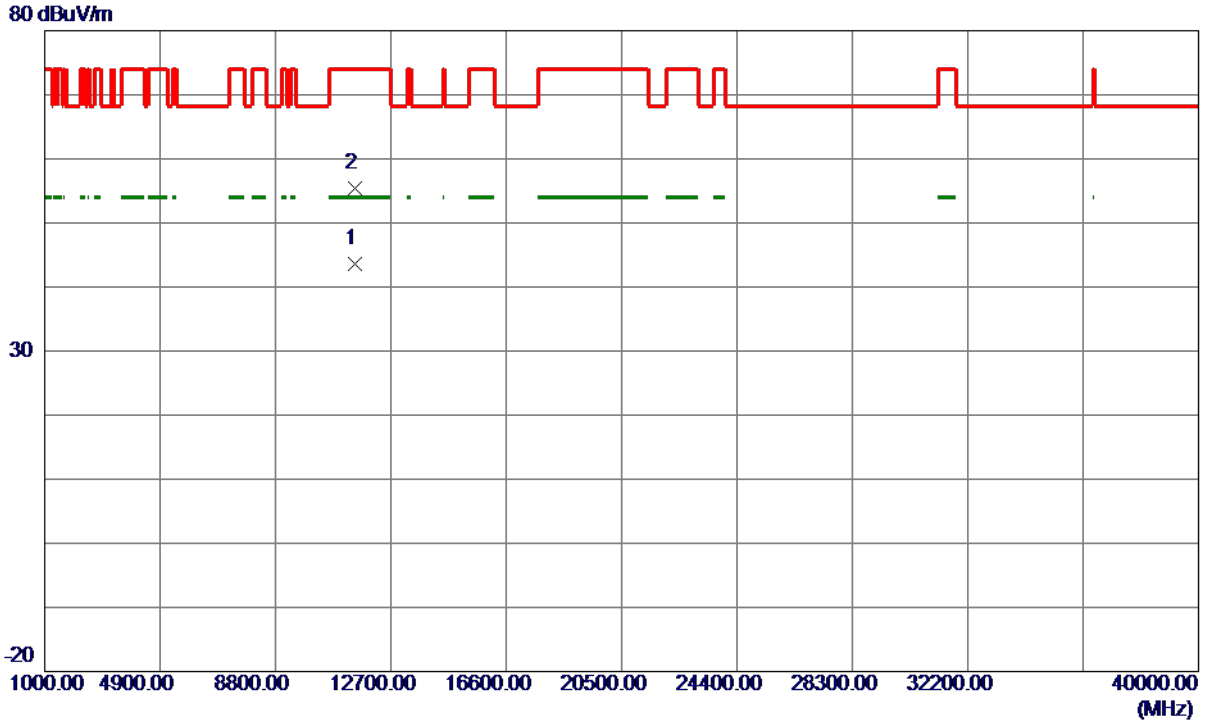

No.	Freq. MHz	Reading Level dBuV/m	Correct Factor dB	Measure ment dBuV/m	Limit dBuV/m	Margin dB	Detector	Comment
1 *	11487.9000	32.86	10.70	43.56	54.00	-10.44	AVG	
2	11488.3400	44.69	10.70	55.39	74.00	-18.61	Peak	

**REMARKS:**

- (1) Measurement Value = Reading Level + Correct Factor.
- (2) Margin Level = Measurement Value - Limit Value.

Orthogonal Axis	X
Test Mode	UNII-3_TX A Mode 5785 MHz

### Vertical

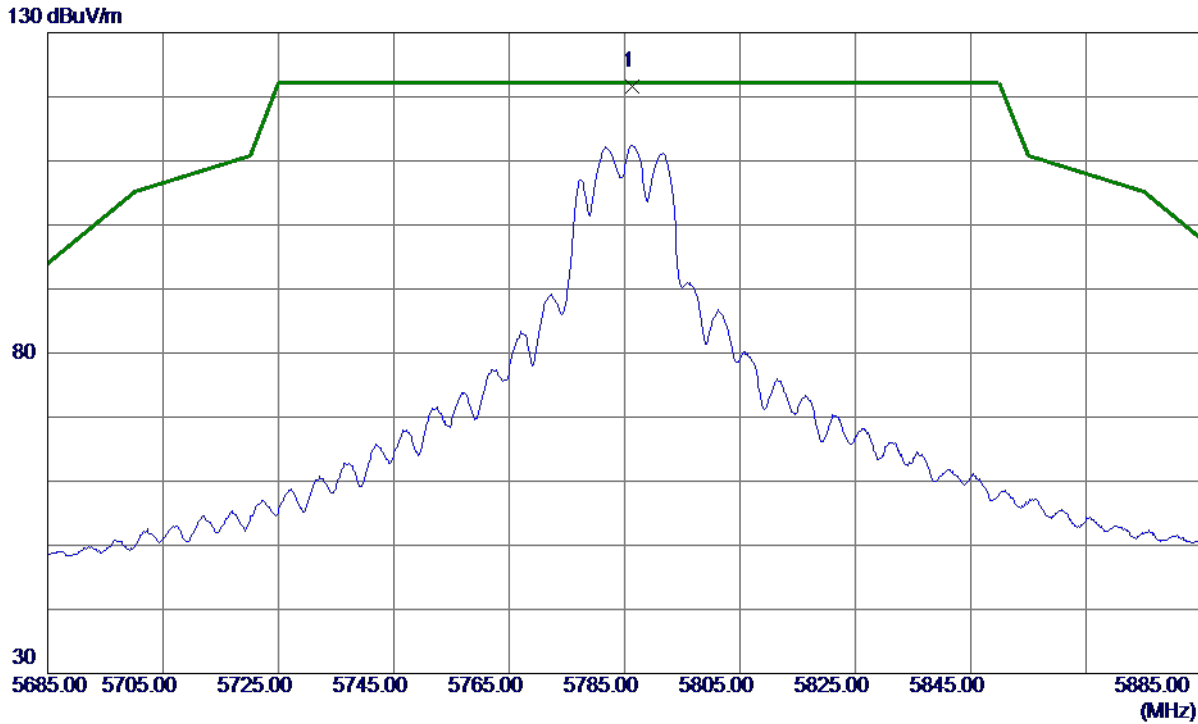

No.	Freq. MHz	Reading Level dBuV/m	Correct Factor dB	Measure ment dBuV/m	Limit dBuV/m	Margin dB	Detector	Comment
1 *	5786.4000	105.57	16.04	121.61	122.20	-0.59	Peak	No Limit

**REMARKS:**

- (1) Measurement Value = Reading Level + Correct Factor.
- (2) Margin Level = Measurement Value - Limit Value.

Orthogonal Axis	X
Test Mode	UNII-3_TX A Mode 5785 MHz

### Vertical

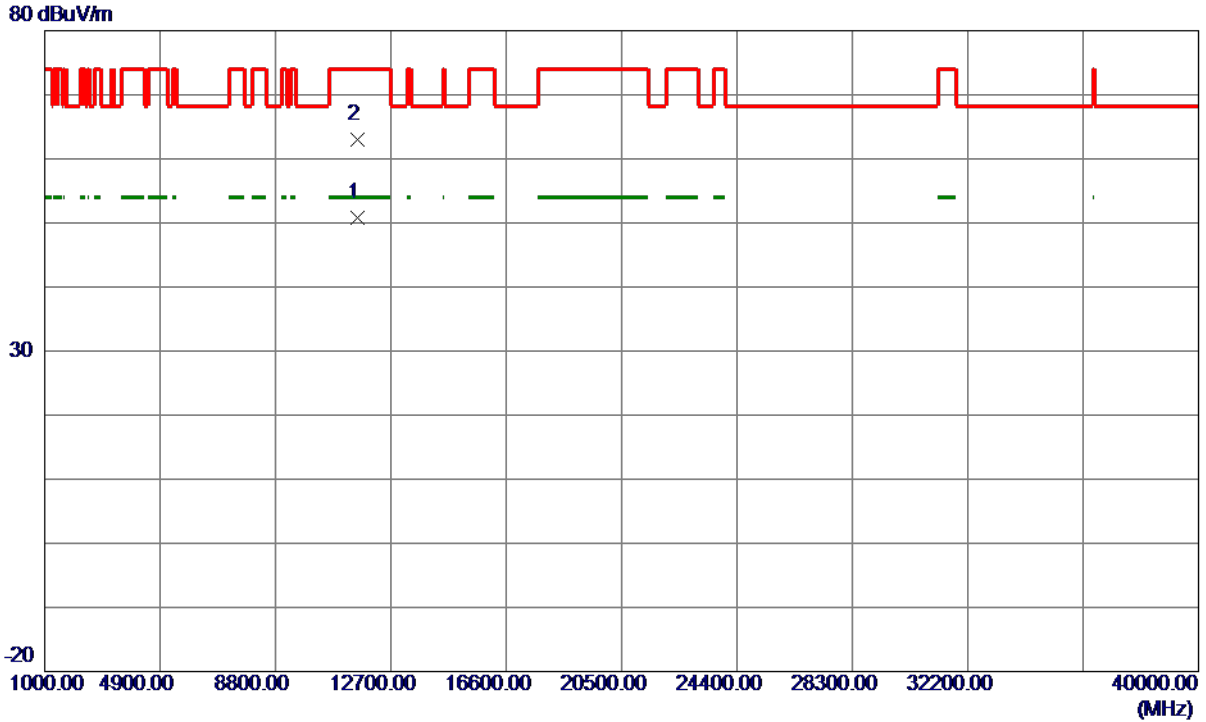

No.	Freq. MHz	Reading Level dBuV/m	Correct Factor dB	Measure ment dBuV/m	Limit dBuV/m	Margin dB	Detector	Comment
1 *	11567.9000	40.02	10.86	50.88	54.00	-3.12	AVG	
2	11568.3800	52.23	10.86	63.09	74.00	-10.91	Peak	

**REMARKS:**

- (1) Measurement Value = Reading Level + Correct Factor.
- (2) Margin Level = Measurement Value - Limit Value.

Orthogonal Axis	X
Test Mode	UNII-3_TX A Mode 5785 MHz

### Horizontal

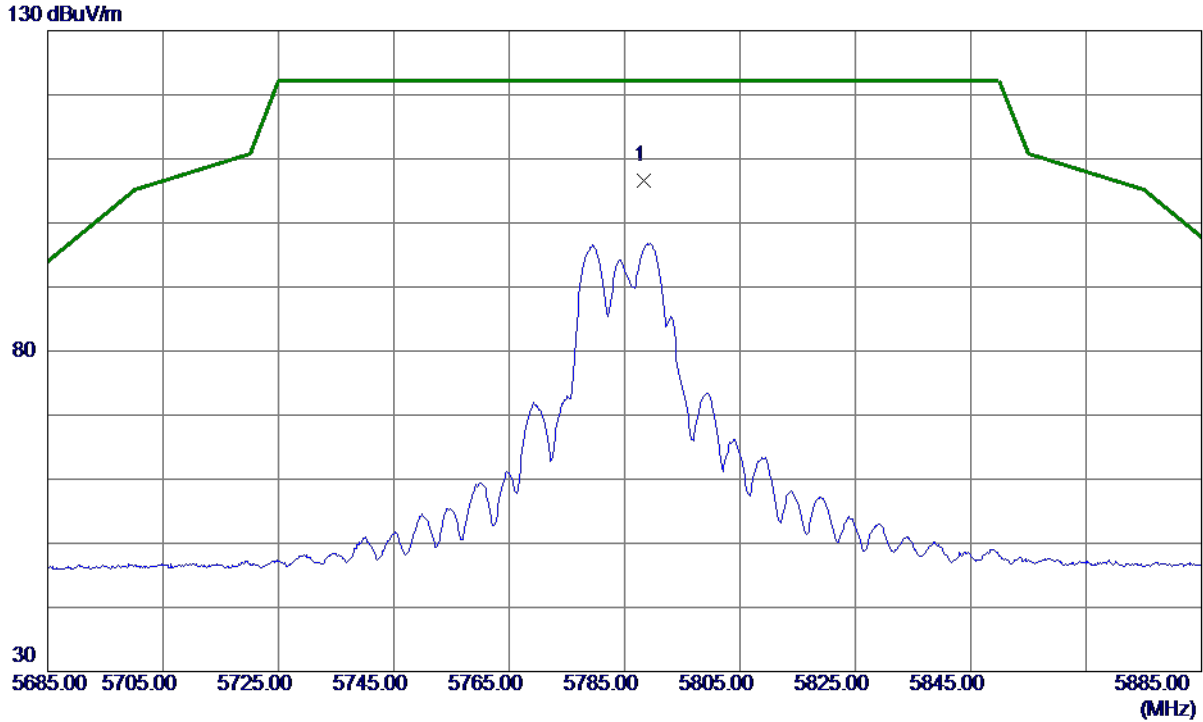

No.	Freq. MHz	Reading Level dBuV/m	Correct Factor dB	Measure ment dBuV/m	Limit dBuV/m	Margin dB	Detector	Comment
1 *	5788.4000	90.57	16.04	106.61	122.20	-15.59	Peak	No Limit

**REMARKS:**

- (1) Measurement Value = Reading Level + Correct Factor.
- (2) Margin Level = Measurement Value - Limit Value.

Orthogonal Axis	X
Test Mode	UNII-3_TX A Mode 5785 MHz

### Horizontal

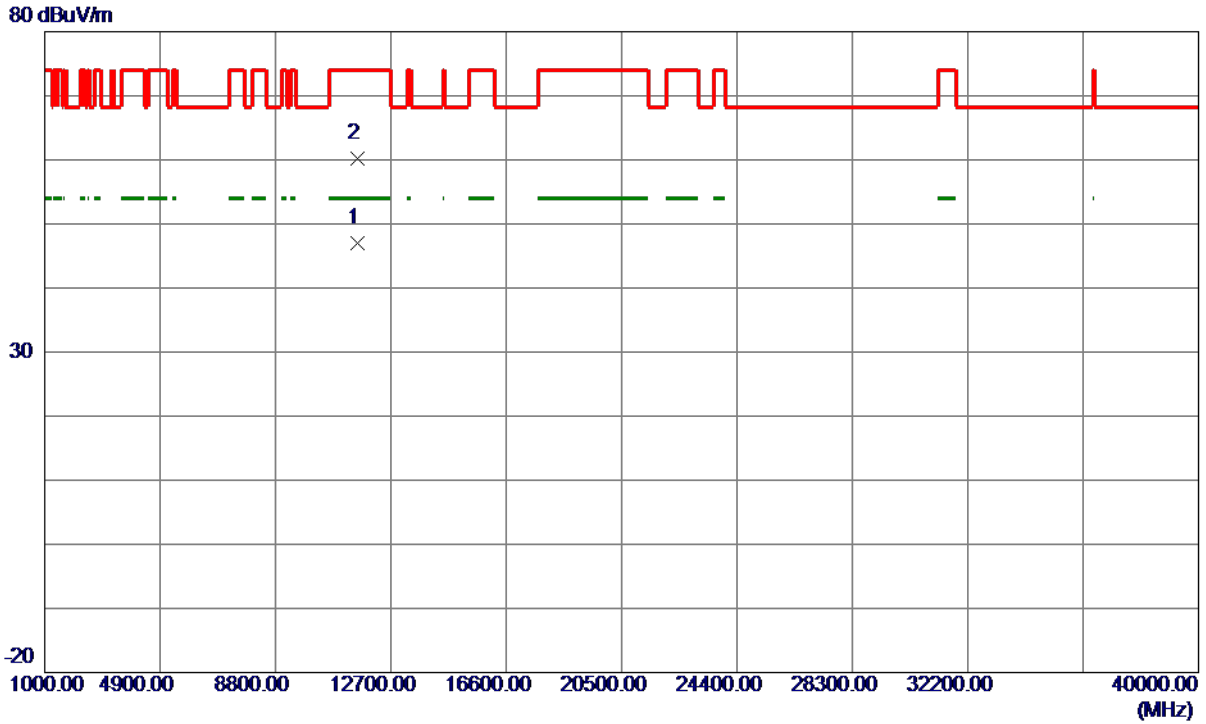

No.	Freq. MHz	Reading Level dBuV/m	Correct Factor dB	Measure ment dBuV/m	Limit dBuV/m	Margin dB	Detector	Comment
1 *	11567.5599	36.11	10.86	46.97	54.00	-7.03	AVG	
2	11568.4800	49.34	10.86	60.20	74.00	-13.80	Peak	

**REMARKS:**

- (1) Measurement Value = Reading Level + Correct Factor.
- (2) Margin Level = Measurement Value - Limit Value.

Orthogonal Axis	X
Test Mode	UNII-3_TX A Mode 5825 MHz

### Vertical

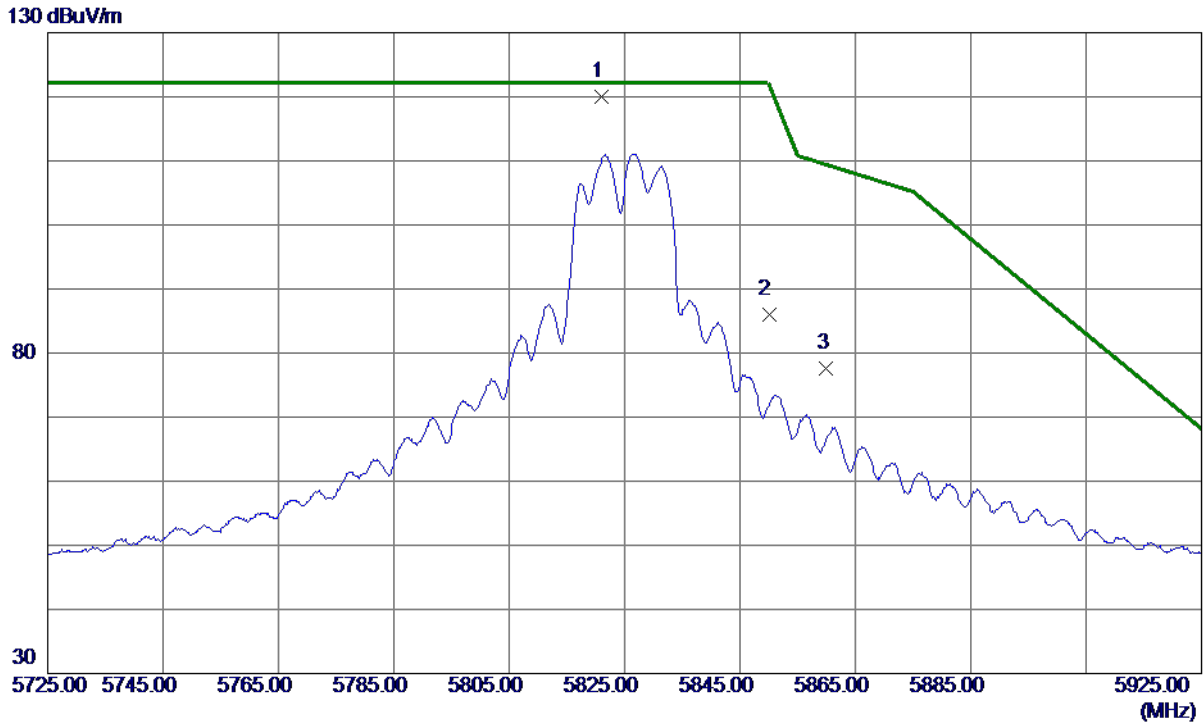

No.	Freq. MHz	Reading Level dBuV/m	Correct Factor dB	Measure ment dBuV/m	Limit dBuV/m	Margin dB	Detector	Comment
1 *	5821.1000	103.85	16.06	119.91	122.20	-2.29	Peak	No Limit
2	5850.0000	69.98	16.08	86.06	122.20	-36.14	Peak	
3	5860.0000	61.52	16.08	77.60	109.40	-31.80	Peak	

**REMARKS:**

- (1) Measurement Value = Reading Level + Correct Factor.
- (2) Margin Level = Measurement Value - Limit Value.

Orthogonal Axis	X
Test Mode	UNII-3_TX A Mode 5825 MHz

### Vertical

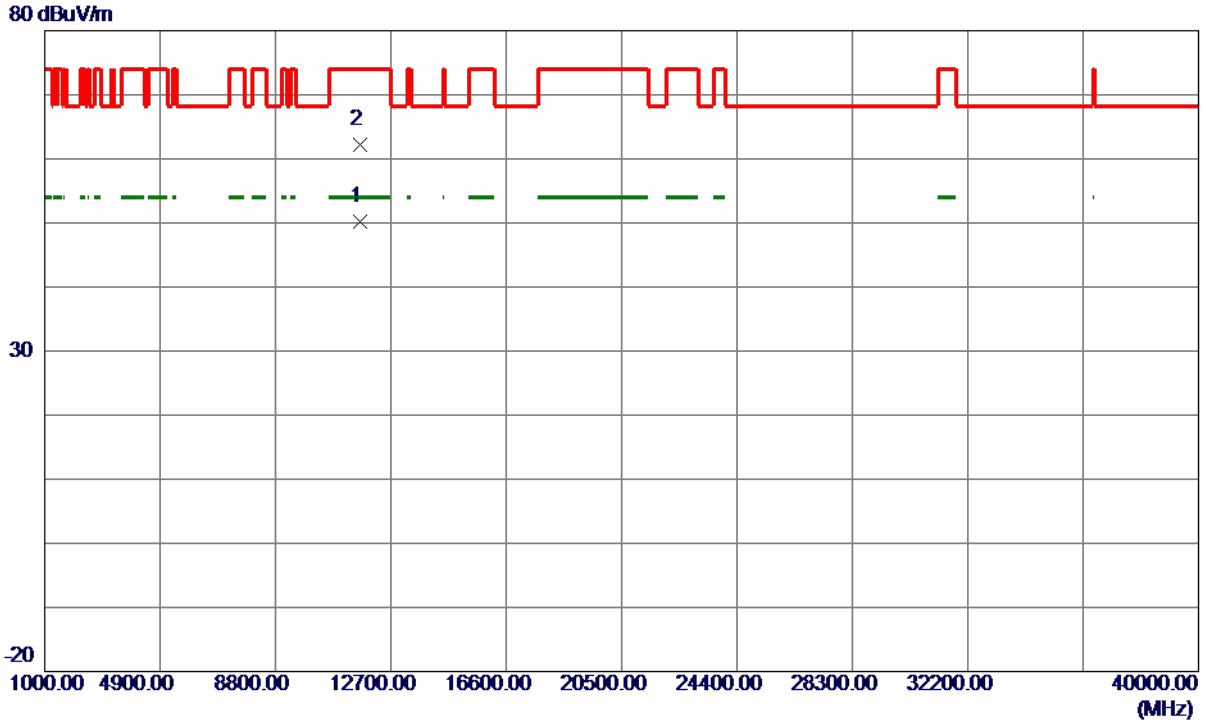

No.	Freq. MHz	Reading Level dBuV/m	Correct Factor dB	Measure ment dBuV/m	Limit dBuV/m	Margin dB	Detector	Comment
1 *	11647.7800	39.16	11.01	50.17	54.00	-3.83	AVG	
2	11648.3000	51.28	11.01	62.29	74.00	-11.71	Peak	

**REMARKS:**

- (1) Measurement Value = Reading Level + Correct Factor.
- (2) Margin Level = Measurement Value - Limit Value.



Orthogonal Axis	X
Test Mode	UNII-3_TX A Mode 5825 MHz

### Horizontal

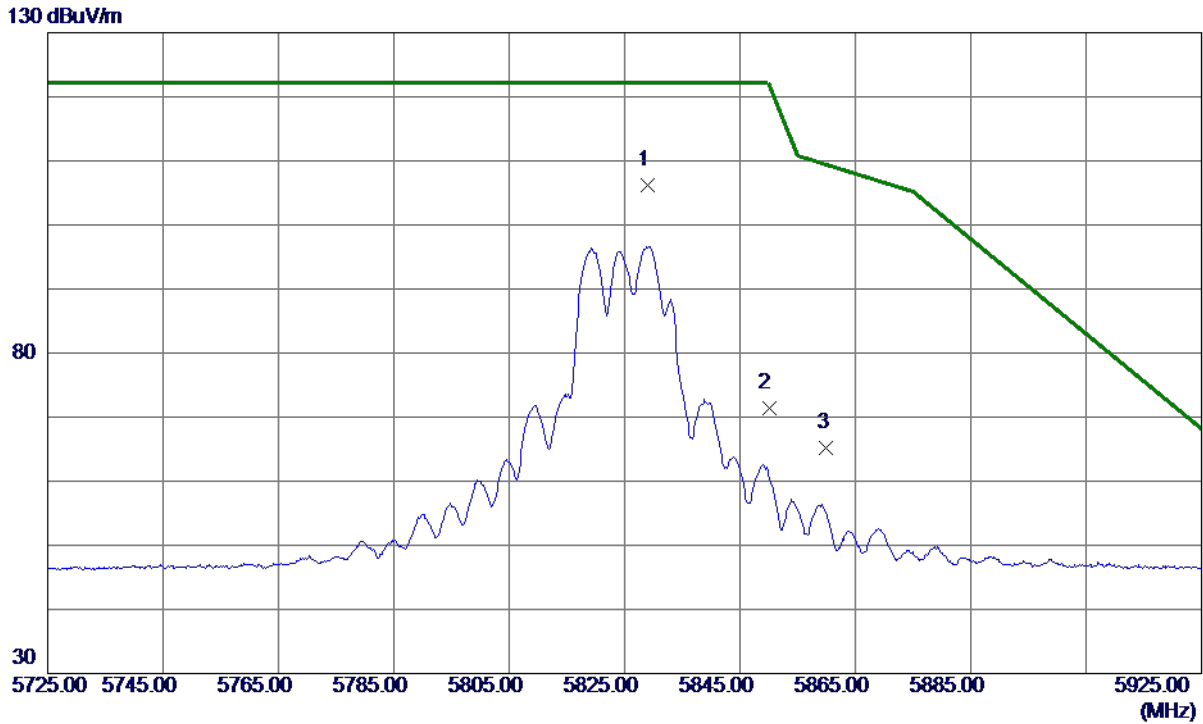

No.	Freq. MHz	Reading Level dBuV/m	Correct Factor dB	Measure ment dBuV/m	Limit dBuV/m	Margin dB	Detector	Comment
1 *	5829.0000	90.06	16.06	106.12	122.20	-16.08	Peak	No Limit
2	5850.0000	55.33	16.08	71.41	122.20	-50.79	Peak	
3	5860.0000	49.18	16.08	65.26	109.40	-44.14	Peak	

**REMARKS:**

- (1) Measurement Value = Reading Level + Correct Factor.
- (2) Margin Level = Measurement Value - Limit Value.

Orthogonal Axis	X
Test Mode	UNII-3_TX A Mode 5825 MHz

### Horizontal

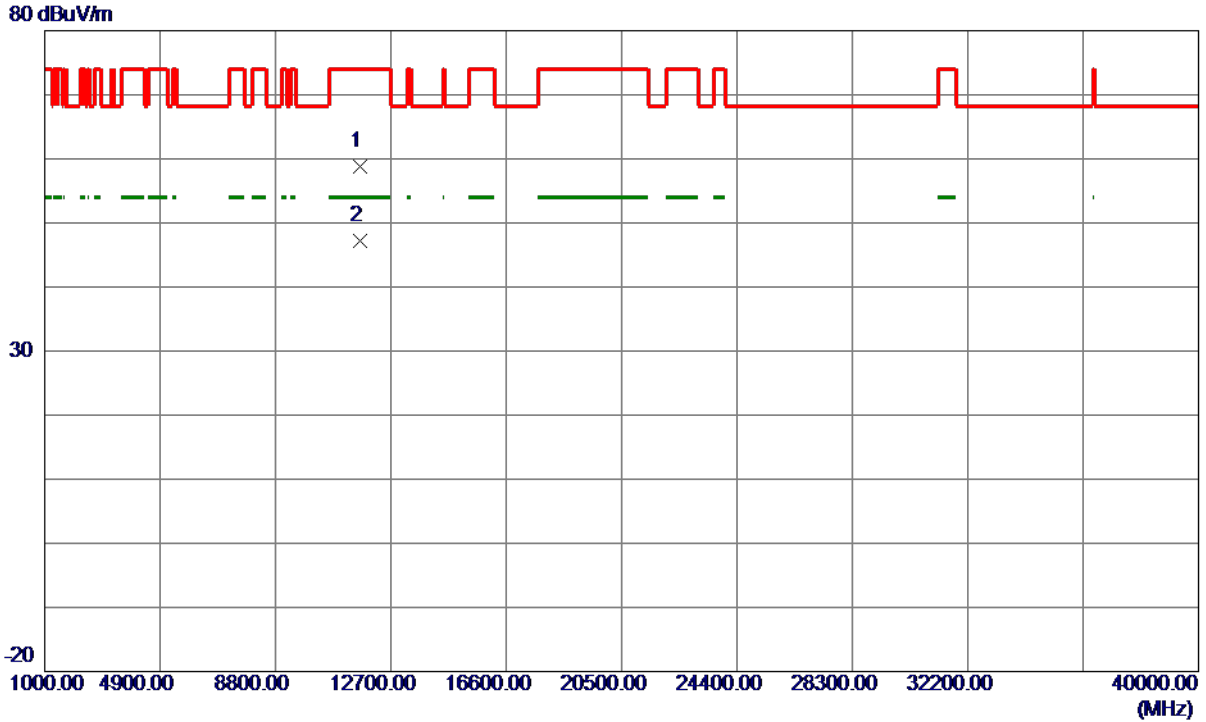

No.	Freq. MHz	Reading Level dBuV/m	Correct Factor dB	Measure ment dBuV/m	Limit dBuV/m	Margin dB	Detector	Comment
1	11646.7800	47.77	11.01	58.78	74.00	-15.22	Peak	
2 *	11647.8200	36.28	11.01	47.29	54.00	-6.71	AVG	

**REMARKS:**

- (1) Measurement Value = Reading Level + Correct Factor.
- (2) Margin Level = Measurement Value - Limit Value.

Orthogonal Axis	X
Test Mode	UNII-1_TX AC (VHT20) Mode 5180 MHz

### Vertical

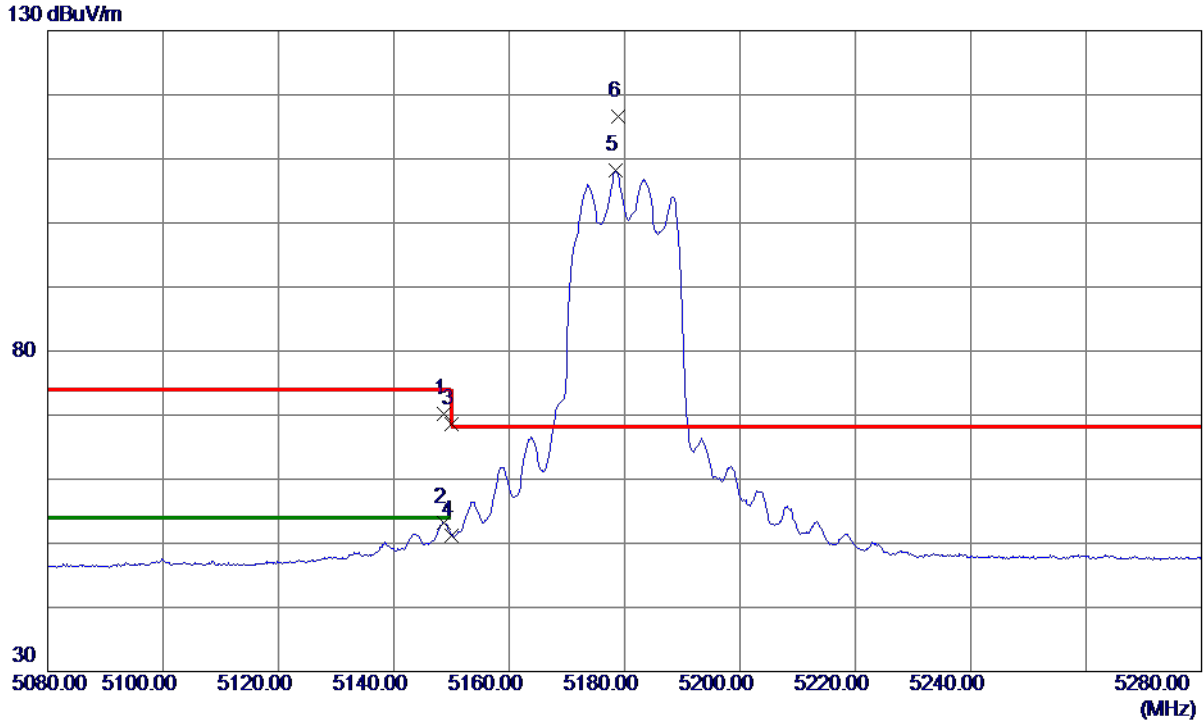

No.	Freq. MHz	Reading Level dBuV/m	Correct Factor dB	Measure ment dBuV/m	Limit dBuV/m	Margin dB	Detector	Comment
1	5148.6000	54.47	15.68	70.15	74.00	-3.85	Peak	
2	5148.6000	37.59	15.68	53.27	54.00	-0.73	AVG	
3	5150.0000	53.01	15.68	68.69	74.00	-5.31	Peak	
4	5150.0000	35.56	15.68	51.24	54.00	-2.76	AVG	
5	5178.5000	92.47	15.70	108.17	999.00	-890.83	AVG	No Limit
6 *	5178.9000	100.90	15.70	116.60	68.30	48.30	Peak	No Limit

**REMARKS:**

- (1) Measurement Value = Reading Level + Correct Factor.
- (2) Margin Level = Measurement Value - Limit Value.

Orthogonal Axis	X
Test Mode	UNII-1_TX AC (VHT20) Mode 5180 MHz

### Vertical

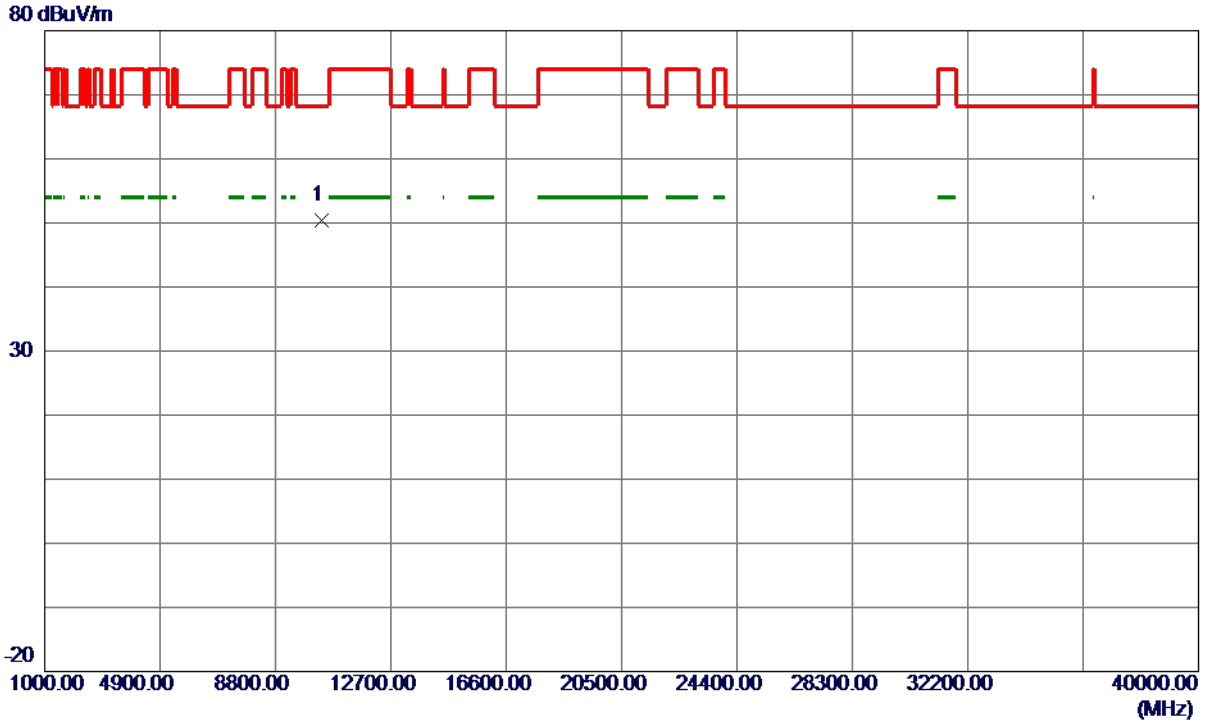

No.	Freq. MHz	Reading Level dBuV/m	Correct Factor dB	Measure ment dBuV/m	Limit dBuV/m	Margin dB	Detector	Comment
1 *	10362.9000	41.50	8.90	50.40	68.30	-17.90	Peak	

**REMARKS:**

- (1) Measurement Value = Reading Level + Correct Factor.
- (2) Margin Level = Measurement Value - Limit Value.

Orthogonal Axis	X
Test Mode	UNII-1_TX AC (VHT20) Mode 5180 MHz

### Horizontal

130 dBuV/m

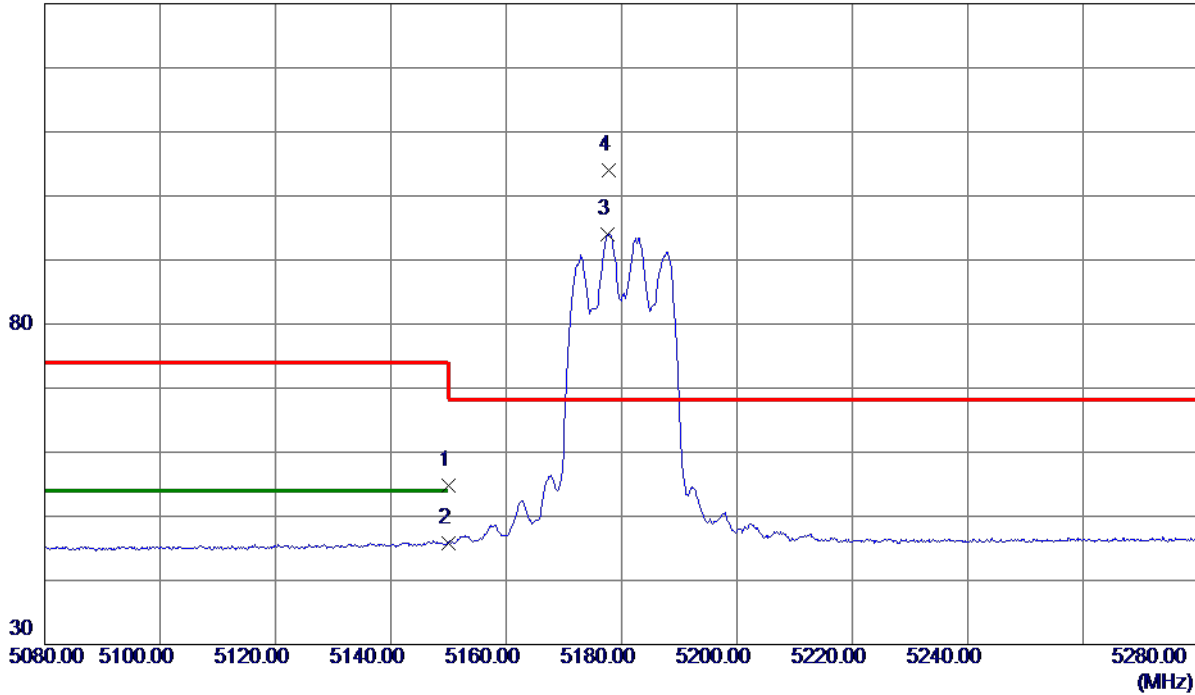

No.	Freq. MHz	Reading Level dBuV/m	Correct Factor dB	Measure ment dBuV/m	Limit dBuV/m	Margin dB	Detector	Comment
1	5150.0000	39.10	15.68	54.78	74.00	-19.22	Peak	
2	5150.0000	30.20	15.68	45.88	54.00	-8.12	AVG	
3	5177.6000	78.40	15.70	94.10	999.00	-904.90	AVG	No Limit
4 *	5177.7000	88.34	15.70	104.04	68.30	35.74	Peak	No Limit

**REMARKS:**

- (1) Measurement Value = Reading Level + Correct Factor.
- (2) Margin Level = Measurement Value - Limit Value.

Orthogonal Axis	X
Test Mode	UNII-1_TX AC (VHT20) Mode 5180 MHz

### Horizontal

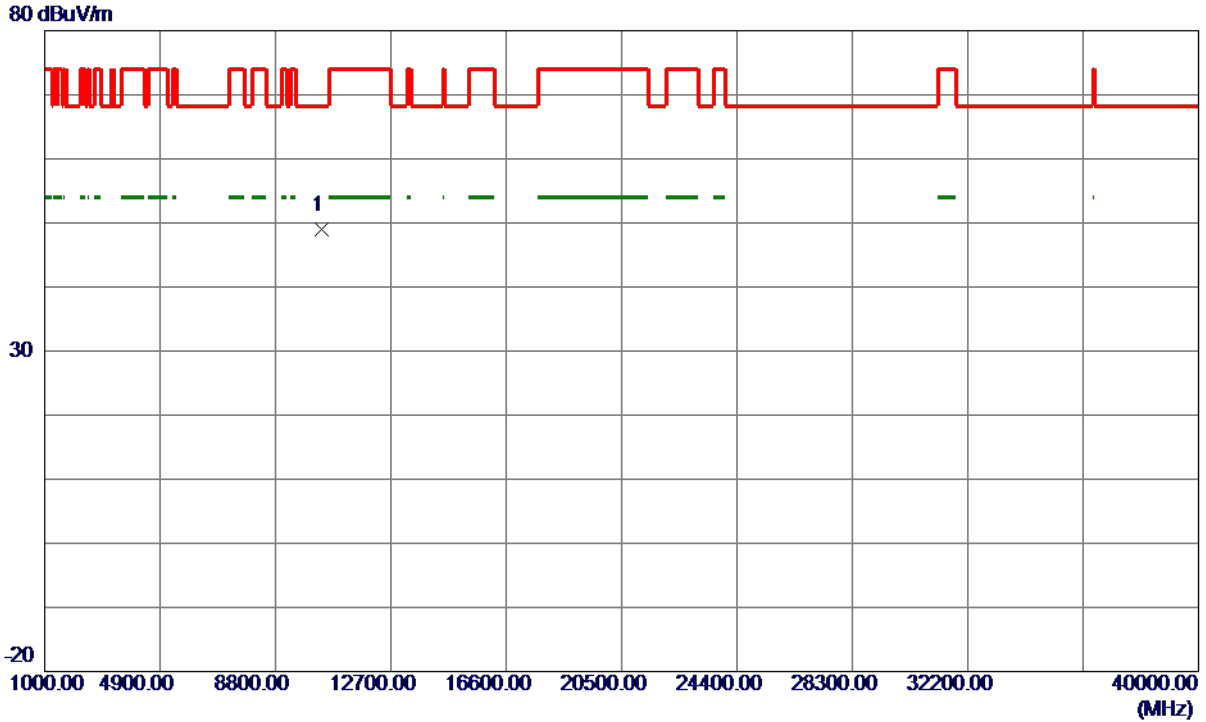

No.	Freq. MHz	Reading Level dBuV/m	Correct Factor dB	Measure ment dBuV/m	Limit dBuV/m	Margin dB	Detector	Comment
1 *	10357.6600	40.01	8.89	48.90	68.30	-19.40	Peak	

**REMARKS:**

- (1) Measurement Value = Reading Level + Correct Factor.
- (2) Margin Level = Measurement Value - Limit Value.

Orthogonal Axis	X
Test Mode	UNII-1_TX AC (VHT20) Mode 5200 MHz

### Vertical

130 dBuV/m

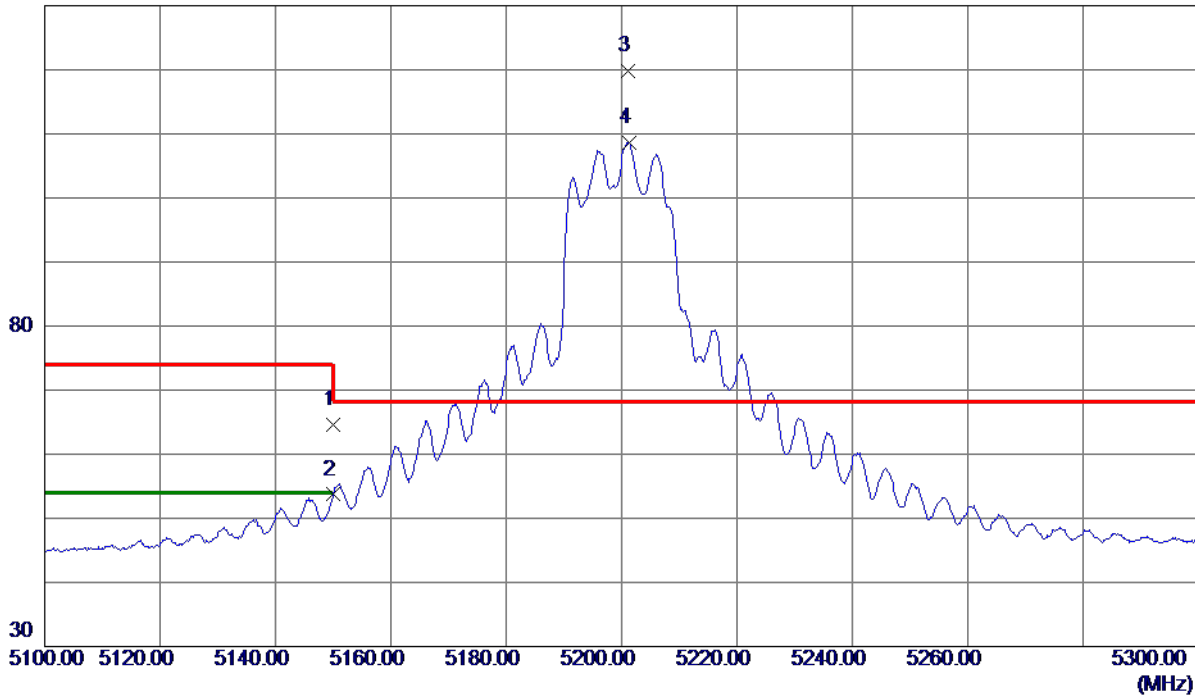

No.	Freq. MHz	Reading Level dBuV/m	Correct Factor dB	Measure ment dBuV/m	Limit dBuV/m	Margin dB	Detector	Comment
1	5150.0000	48.84	15.68	64.52	74.00	-9.48	Peak	
2	5150.0000	38.02	15.68	53.70	54.00	-0.30	AVG	
3 *	5201.1000	104.01	15.71	119.72	68.30	51.42	Peak	No Limit
4	5201.3000	92.97	15.71	108.68	999.00	-890.32	AVG	No Limit

**REMARKS:**

- (1) Measurement Value = Reading Level + Correct Factor.
- (2) Margin Level = Measurement Value - Limit Value.

Orthogonal Axis	X
Test Mode	UNII-1_TX AC (VHT20) Mode 5200 MHz

### Vertical

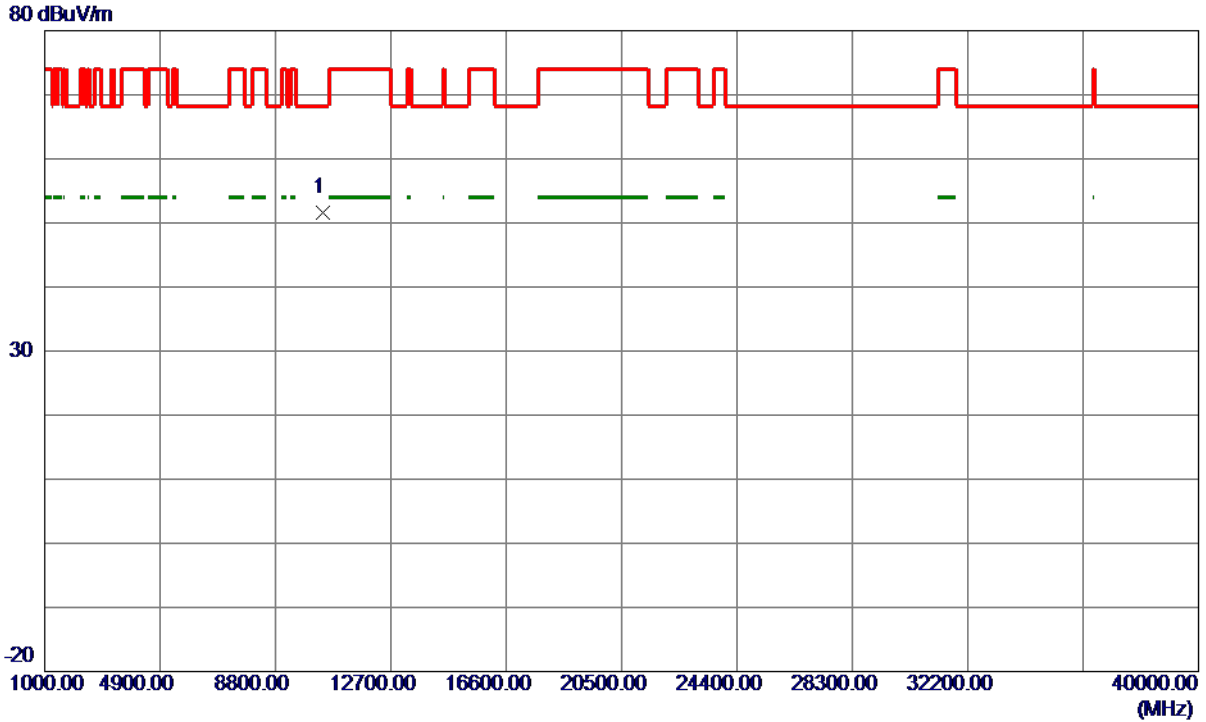

No.	Freq. MHz	Reading Level dBuV/m	Correct Factor dB	Measure ment dBuV/m	Limit dBuV/m	Margin dB	Detector	Comment
1 *	10393.5800	42.65	8.96	51.61	68.30	-16.69	Peak	

**REMARKS:**

- (1) Measurement Value = Reading Level + Correct Factor.
- (2) Margin Level = Measurement Value - Limit Value.



Orthogonal Axis	X
Test Mode	UNII-1_TX AC (VHT20) Mode 5200 MHz

### Horizontal

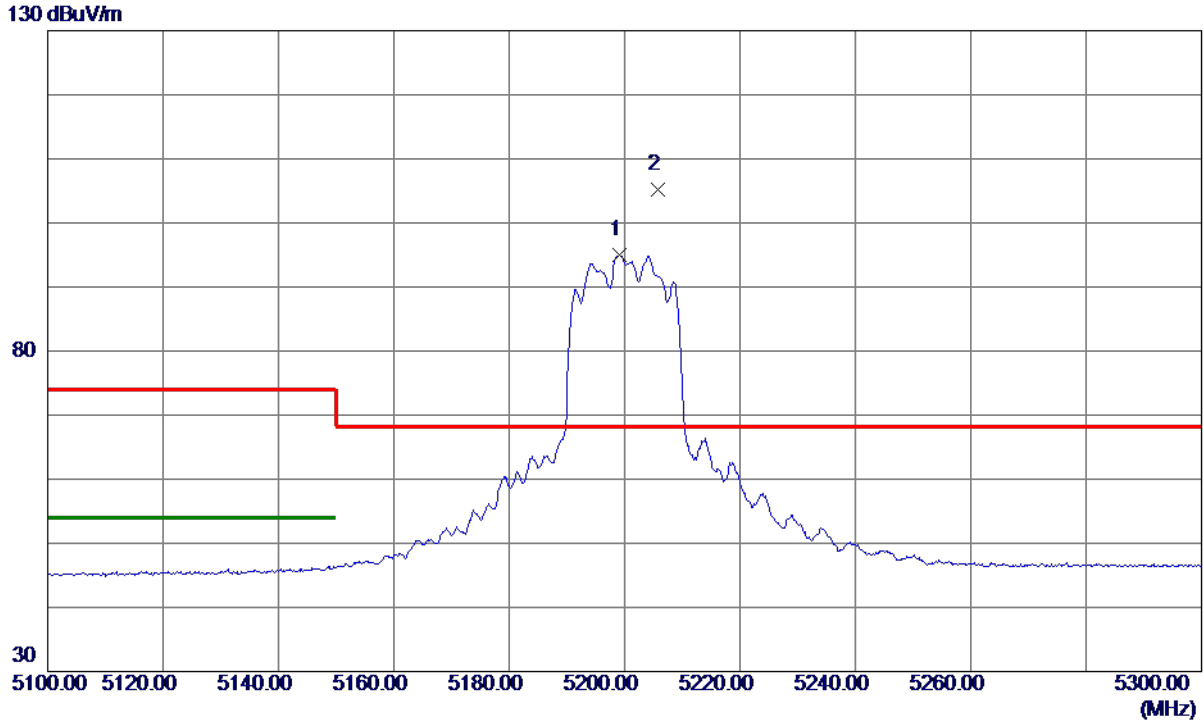

No.	Freq. MHz	Reading Level dBuV/m	Correct Factor dB	Measure ment dBuV/m	Limit dBuV/m	Margin dB	Detector	Comment
1	5199.1000	79.34	15.71	95.05	999.00	-903.95	AVG	No Limit
2 *	5205.7000	89.55	15.71	105.26	68.30	36.96	Peak	No Limit

**REMARKS:**

- (1) Measurement Value = Reading Level + Correct Factor.
- (2) Margin Level = Measurement Value - Limit Value.

Orthogonal Axis	X
Test Mode	UNII-1_TX AC (VHT20) Mode 5200 MHz

### Horizontal

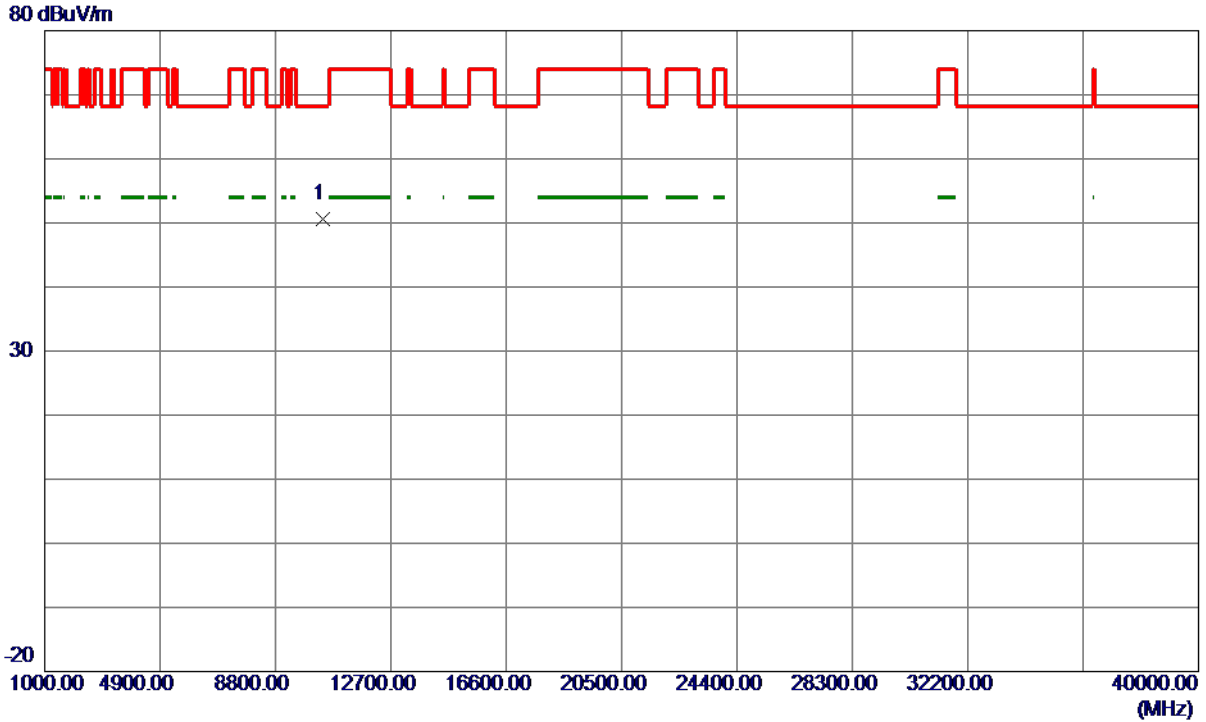

No.	Freq. MHz	Reading Level dBuV/m	Correct Factor dB	Measure ment dBuV/m	Limit dBuV/m	Margin dB	Detector	Comment
1 *	10398.5400	41.71	8.97	50.68	68.30	-17.62	Peak	

**REMARKS:**

- (1) Measurement Value = Reading Level + Correct Factor.
- (2) Margin Level = Measurement Value - Limit Value.

Orthogonal Axis	X
Test Mode	UNII-1_TX AC (VHT20) Mode 5240 MHz

### Vertical

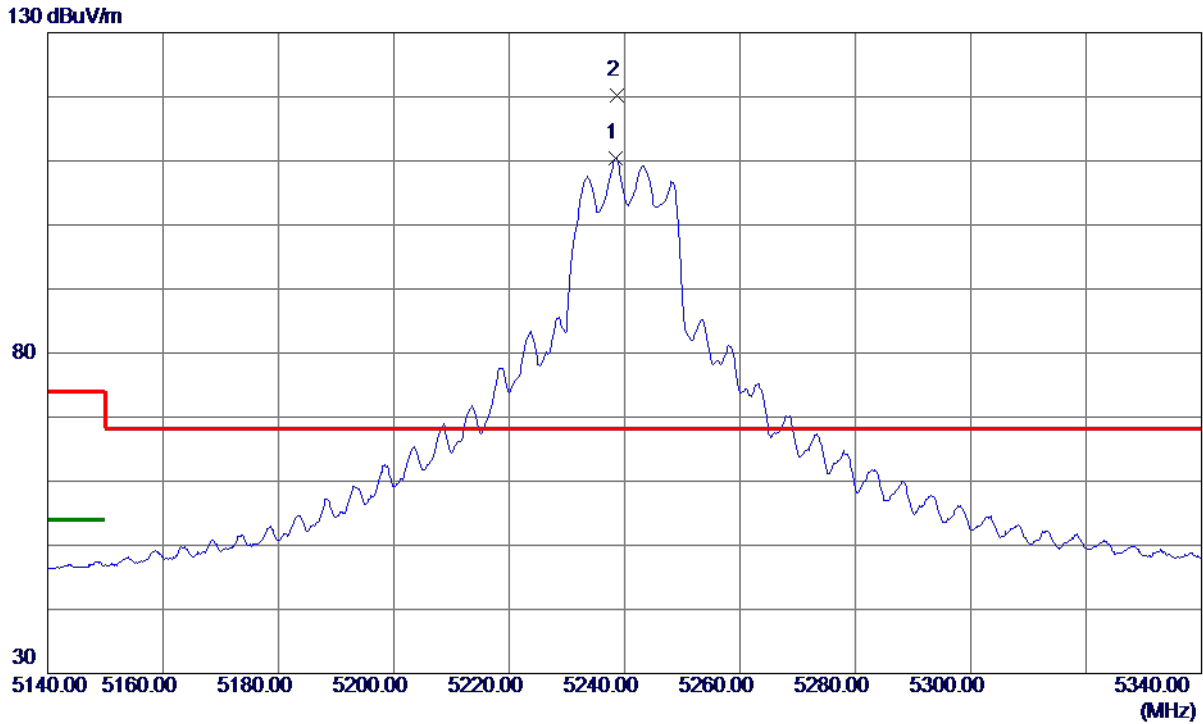

No.	Freq. MHz	Reading Level dBuV/m	Correct Factor dB	Measure ment dBuV/m	Limit dBuV/m	Margin dB	Detector	Comment
1	5238.4000	94.73	15.73	110.46	999.00	-888.54	AVG	No Limit
2 *	5238.6000	104.38	15.73	120.11	68.30	51.81	Peak	No Limit

**REMARKS:**

- (1) Measurement Value = Reading Level + Correct Factor.
- (2) Margin Level = Measurement Value - Limit Value.

Orthogonal Axis	X
Test Mode	UNII-1_TX AC (VHT20) Mode 5240 MHz

### Vertical



No.	Freq. MHz	Reading Level dBuV/m	Correct Factor dB	Measure ment dBuV/m	Limit dBuV/m	Margin dB	Detector	Comment
1 *	10476.4800	41.17	9.12	50.29	68.30	-18.01	Peak	

**REMARKS:**

- (1) Measurement Value = Reading Level + Correct Factor.
- (2) Margin Level = Measurement Value - Limit Value.

Orthogonal Axis	X
Test Mode	UNII-1_TX AC (VHT20) Mode 5240 MHz

### Horizontal

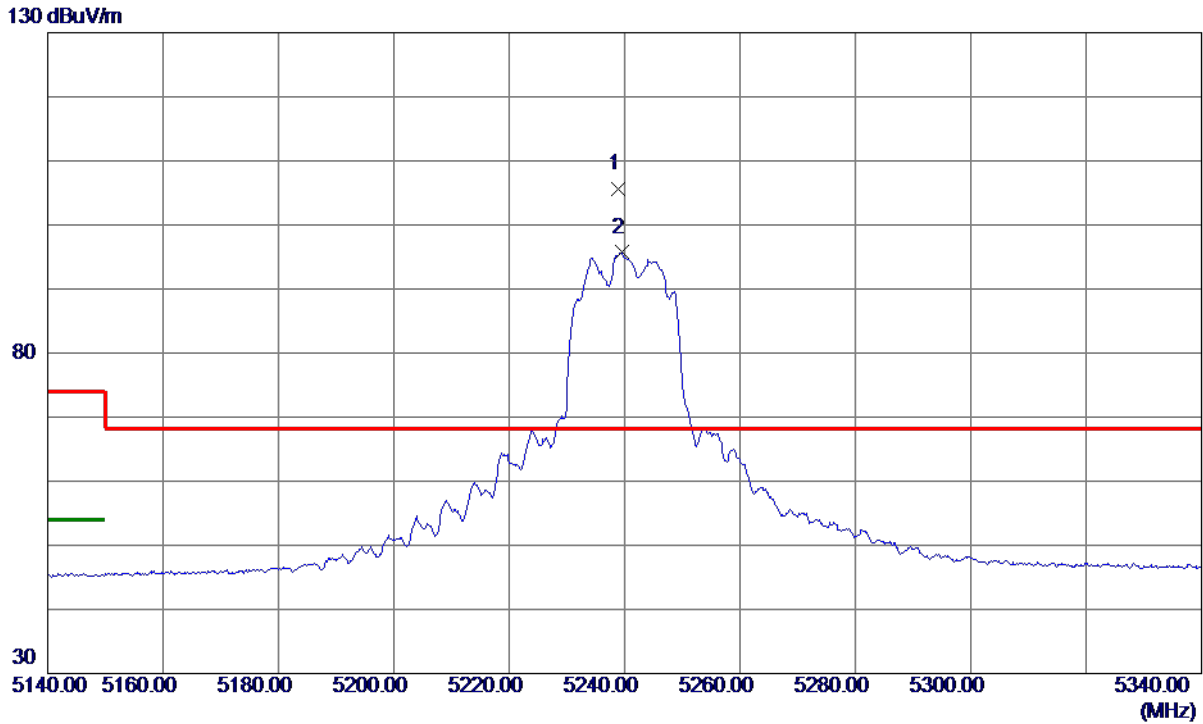

No.	Freq. MHz	Reading Level dBuV/m	Correct Factor dB	Measure ment dBuV/m	Limit dBuV/m	Margin dB	Detector	Comment
1 *	5238.8000	89.95	15.73	105.68	68.30	37.38	Peak	No Limit
2	5239.5000	79.97	15.73	95.70	999.00	-903.30	AVG	No Limit

**REMARKS:**

- (1) Measurement Value = Reading Level + Correct Factor.
- (2) Margin Level = Measurement Value - Limit Value.

Orthogonal Axis	X
Test Mode	UNII-1_TX AC (VHT20) Mode 5240 MHz

### Horizontal

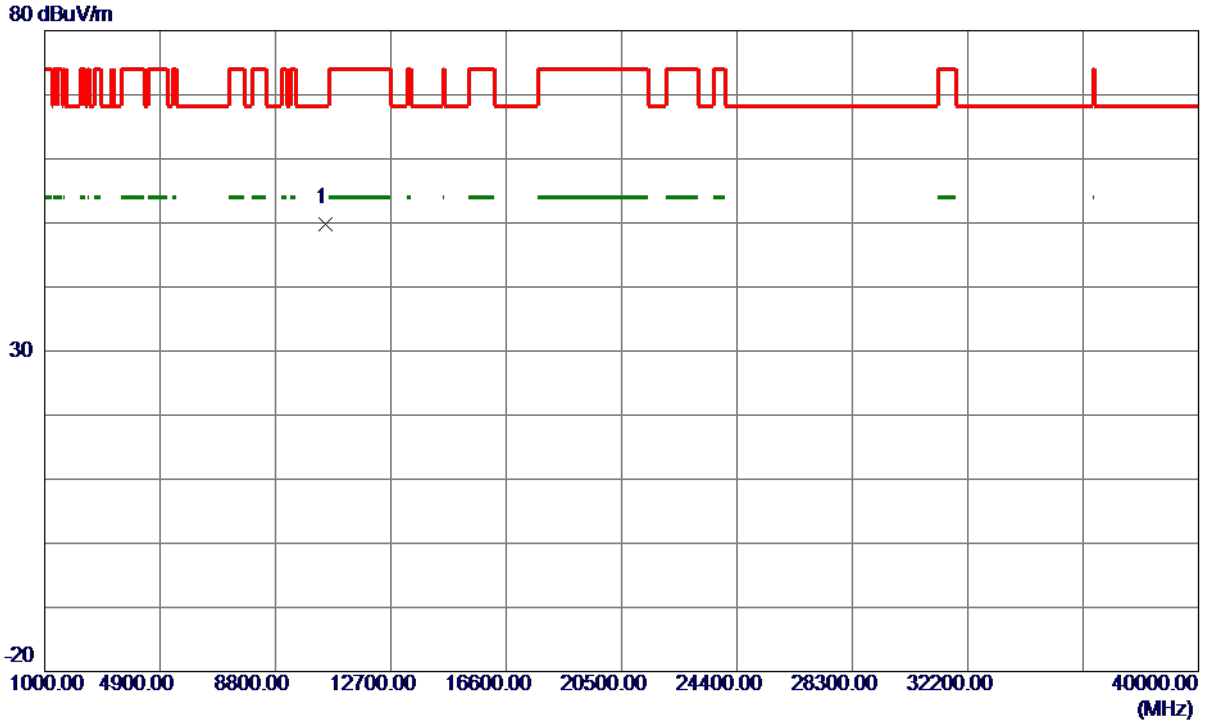

No.	Freq. MHz	Reading Level dBuV/m	Correct Factor dB	Measure ment dBuV/m	Limit dBuV/m	Margin dB	Detector	Comment
1 *	10480.7800	40.78	9.12	49.90	68.30	-18.40	Peak	

**REMARKS:**

- (1) Measurement Value = Reading Level + Correct Factor.
- (2) Margin Level = Measurement Value - Limit Value.

Orthogonal Axis	X
Test Mode	UNII-1_TX AC (VHT40) Mode 5190 MHz

### Vertical

130 dBuV/m

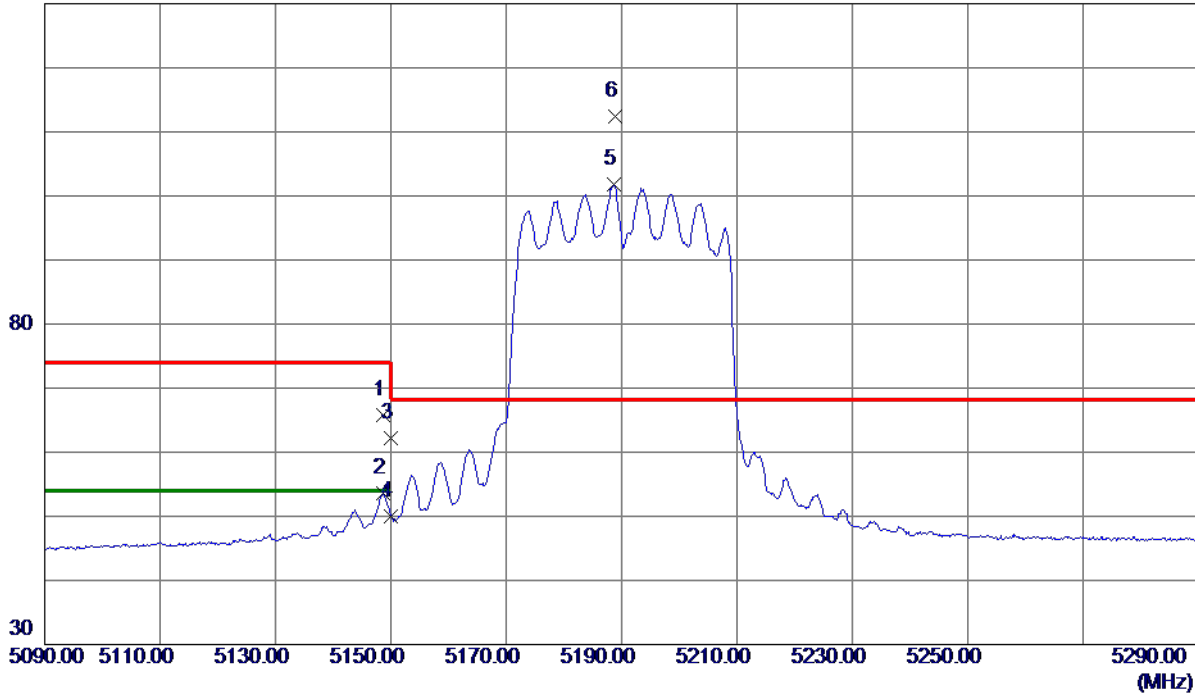

No.	Freq. MHz	Reading Level dBuV/m	Correct Factor dB	Measure ment dBuV/m	Limit dBuV/m	Margin dB	Detector	Comment
1	5148.6000	50.17	15.68	65.85	74.00	-8.15	Peak	
2	5148.6000	37.83	15.68	53.51	54.00	-0.49	AVG	
3	5150.0000	46.59	15.68	62.27	74.00	-11.73	Peak	
4	5150.0000	34.39	15.68	50.07	54.00	-3.93	AVG	
5	5188.6000	86.08	15.70	101.78	999.00	-897.22	AVG	No Limit
6 *	5188.8000	96.70	15.70	112.40	68.30	44.10	Peak	No Limit

**REMARKS:**

- (1) Measurement Value = Reading Level + Correct Factor.
- (2) Margin Level = Measurement Value - Limit Value.

Orthogonal Axis	X
Test Mode	UNII-1_TX AC (VHT40) Mode 5190 MHz

### Vertical

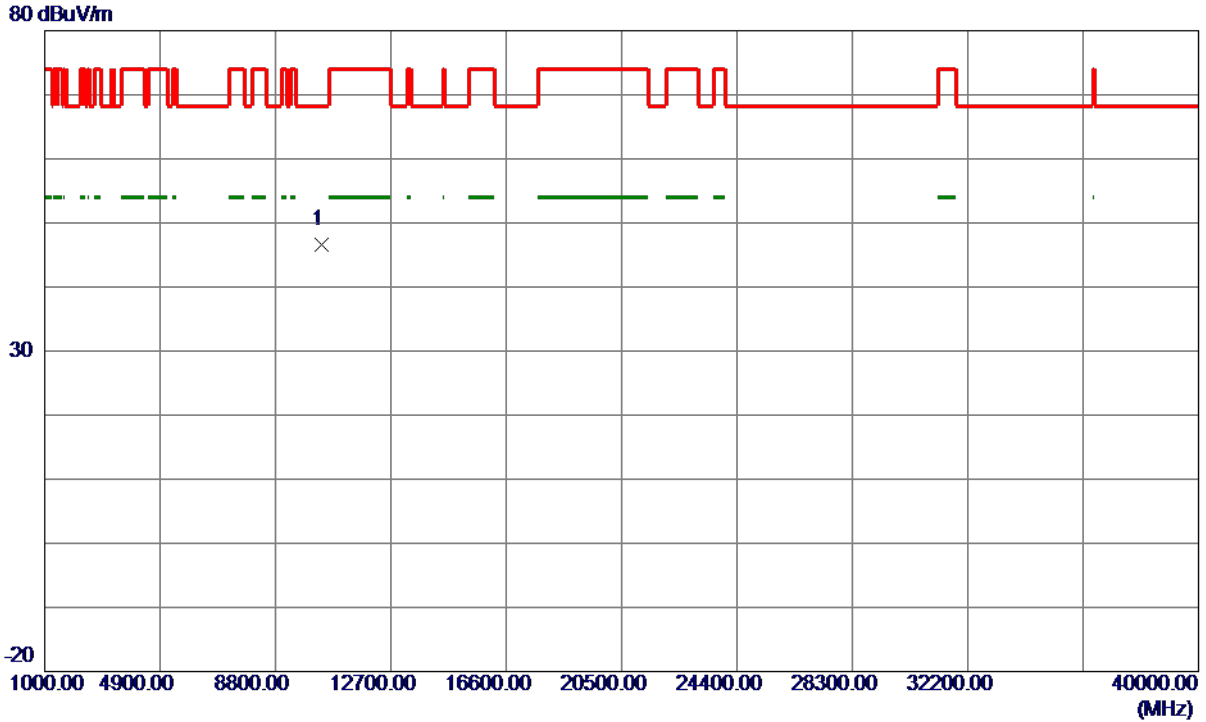

No.	Freq. MHz	Reading Level dBuV/m	Correct Factor dB	Measure ment dBuV/m	Limit dBuV/m	Margin dB	Detector	Comment
1 *	10377.7200	37.65	8.93	46.58	68.30	-21.72	Peak	

**REMARKS:**

- (1) Measurement Value = Reading Level + Correct Factor.
- (2) Margin Level = Measurement Value - Limit Value.



Orthogonal Axis	X
Test Mode	UNII-1_TX AC (VHT40) Mode 5190 MHz

### Horizontal

130 dBuV/m

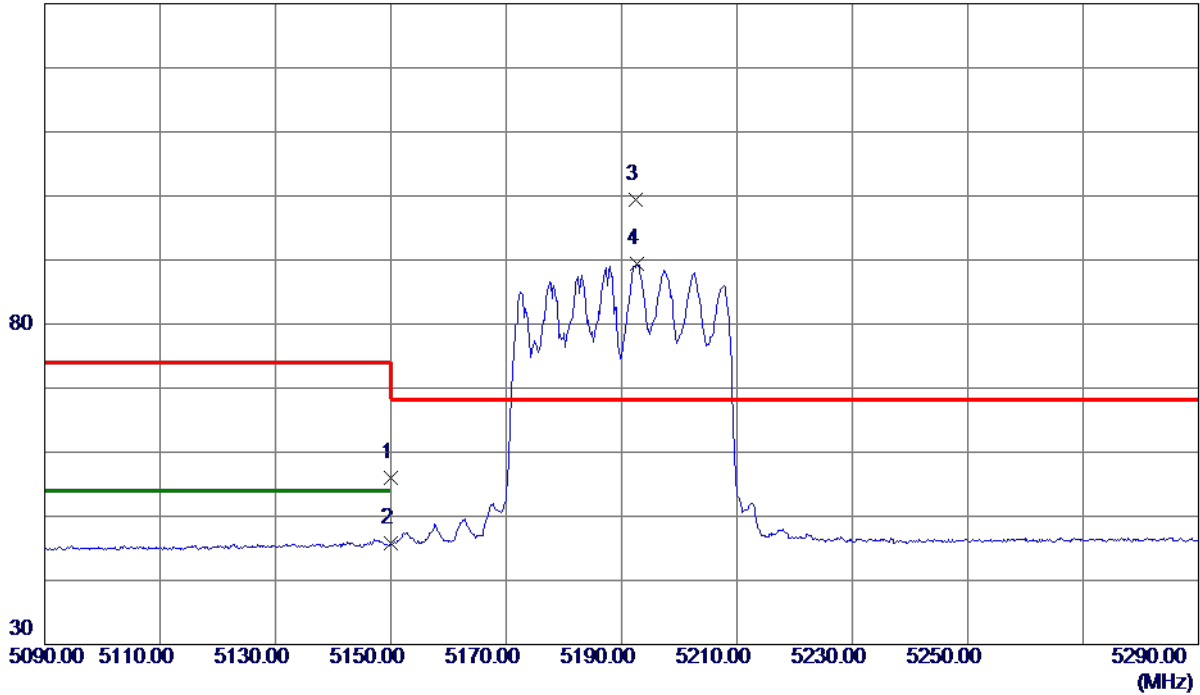

No.	Freq. MHz	Reading Level dBuV/m	Correct Factor dB	Measure ment dBuV/m	Limit dBuV/m	Margin dB	Detector	Comment
1	5150.0000	40.39	15.68	56.07	74.00	-17.93	Peak	
2	5150.0000	30.20	15.68	45.88	54.00	-8.12	AVG	
3 *	5192.4000	83.68	15.71	99.39	68.30	31.09	Peak	No Limit
4	5192.6000	73.74	15.71	89.45	999.00	-909.55	AVG	No Limit

**REMARKS:**

- (1) Measurement Value = Reading Level + Correct Factor.
- (2) Margin Level = Measurement Value - Limit Value.

Orthogonal Axis	X
Test Mode	UNII-1_TX AC (VHT40) Mode 5190 MHz

### Horizontal

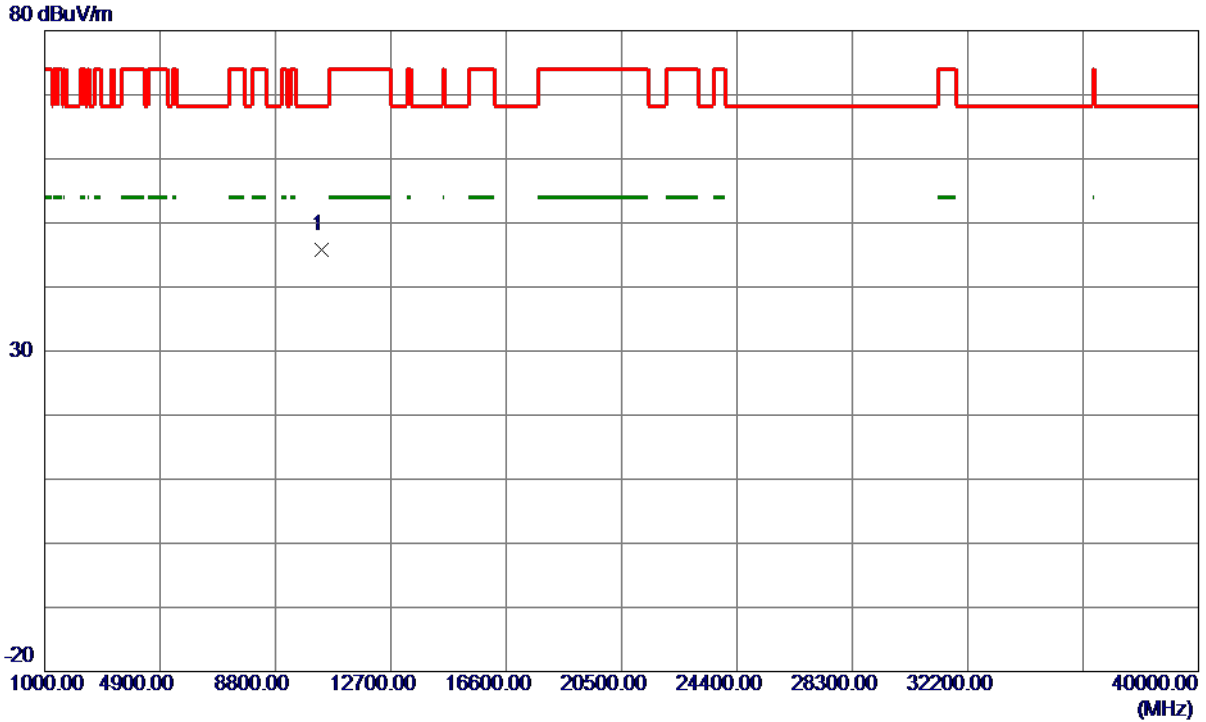

No.	Freq. MHz	Reading Level dBuV/m	Correct Factor dB	Measure ment dBuV/m	Limit dBuV/m	Margin dB	Detector	Comment
1 *	10378.7000	36.85	8.93	45.78	68.30	-22.52	Peak	

**REMARKS:**

- (1) Measurement Value = Reading Level + Correct Factor.
- (2) Margin Level = Measurement Value - Limit Value.

Orthogonal Axis	X
Test Mode	UNII-1_TX AC (VHT40) Mode 5230 MHz

### Vertical

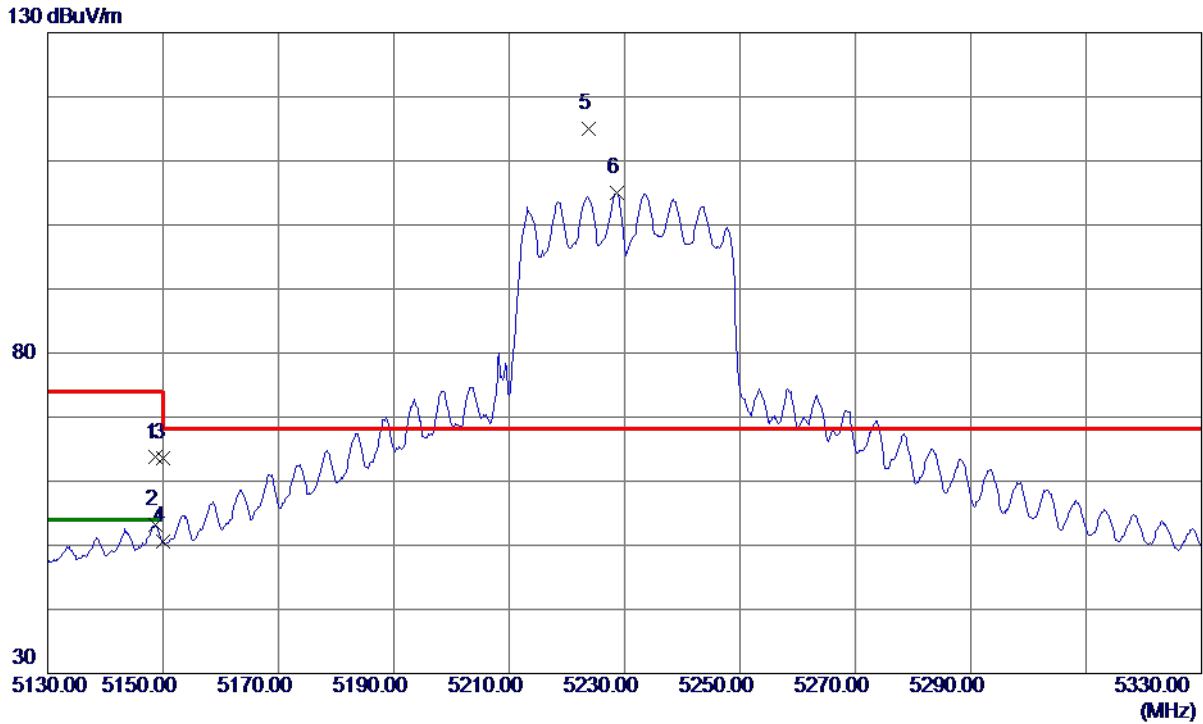

No.	Freq. MHz	Reading Level dBuV/m	Correct Factor dB	Measure ment dBuV/m	Limit dBuV/m	Margin dB	Detector	Comment
1	5148.7000	48.02	15.68	63.70	74.00	-10.30	Peak	
2	5148.7000	37.44	15.68	53.12	54.00	-0.88	AVG	
3	5150.0000	47.99	15.68	63.67	74.00	-10.33	Peak	
4	5150.0000	34.94	15.68	50.62	54.00	-3.38	AVG	
5 *	5223.7000	99.21	15.72	114.93	68.30	46.63	Peak	No Limit
6	5228.6000	89.20	15.72	104.92	999.00	-894.08	AVG	No Limit

**REMARKS:**

- (1) Measurement Value = Reading Level + Correct Factor.
- (2) Margin Level = Measurement Value - Limit Value.

Orthogonal Axis	X
Test Mode	UNII-1_TX AC (VHT40) Mode 5230 MHz

### Vertical

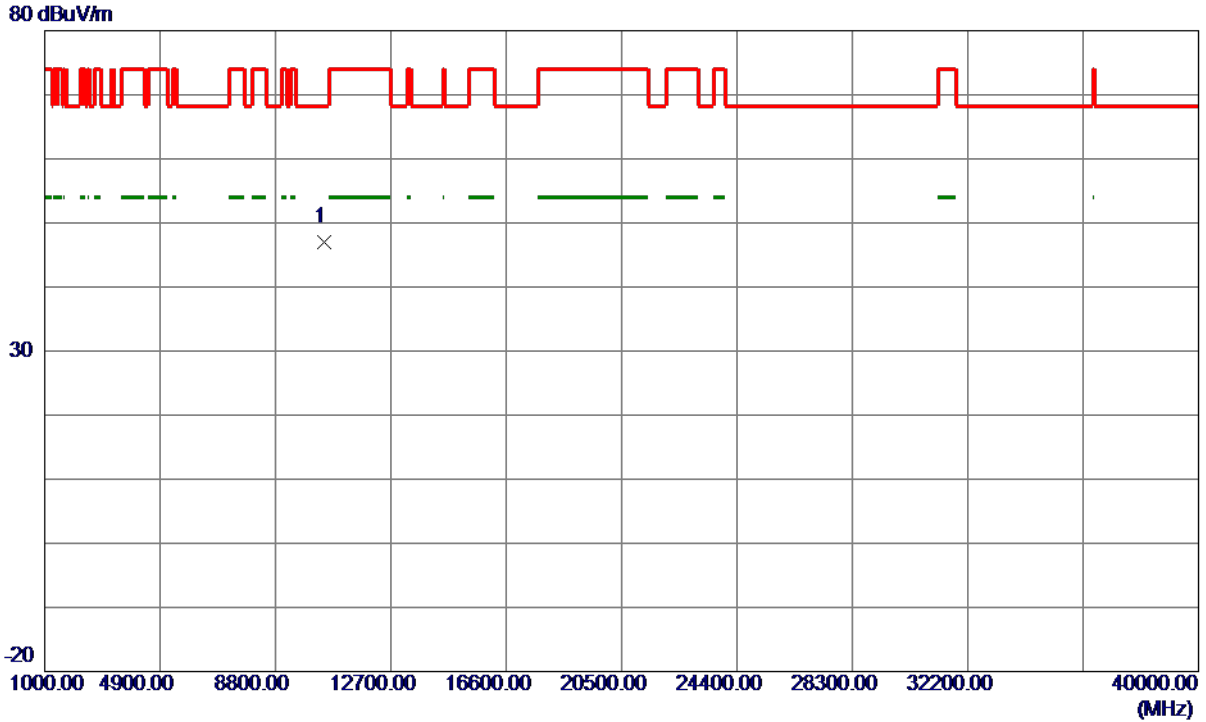

No.	Freq. MHz	Reading Level dBuV/m	Correct Factor dB	Measure ment dBuV/m	Limit dBuV/m	Margin dB	Detector	Comment
1 *	10461.0400	37.98	9.09	47.07	68.30	-21.23	Peak	

**REMARKS:**

- (1) Measurement Value = Reading Level + Correct Factor.
- (2) Margin Level = Measurement Value - Limit Value.

Orthogonal Axis	X
Test Mode	UNII-1_TX AC (VHT40) Mode 5230 MHz

### Horizontal

130 dBuV/m

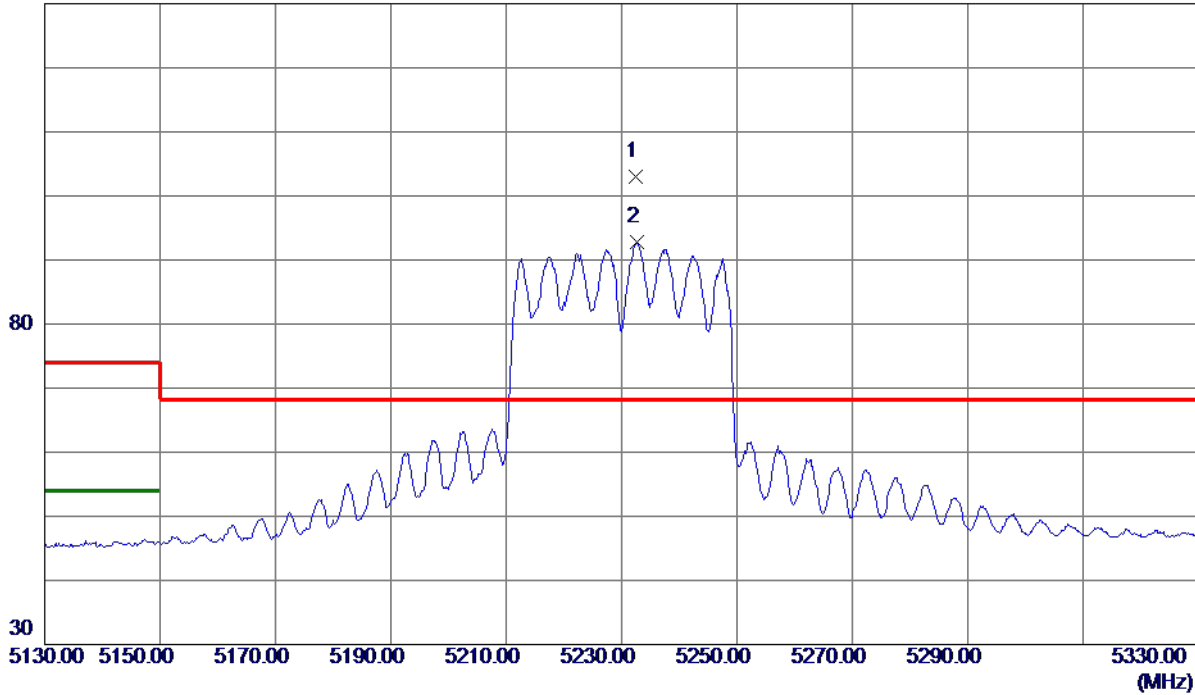

No.	Freq. MHz	Reading Level dBuV/m	Correct Factor dB	Measure ment dBuV/m	Limit dBuV/m	Margin dB	Detector	Comment
1 *	5232.4000	87.32	15.73	103.05	68.30	34.75	Peak	No Limit
2	5232.6000	76.98	15.73	92.71	999.00	-906.29	AVG	No Limit

**REMARKS:**

- (1) Measurement Value = Reading Level + Correct Factor.
- (2) Margin Level = Measurement Value - Limit Value.

Orthogonal Axis	X
Test Mode	UNII-1_TX AC (VHT40) Mode 5230 MHz

### Horizontal

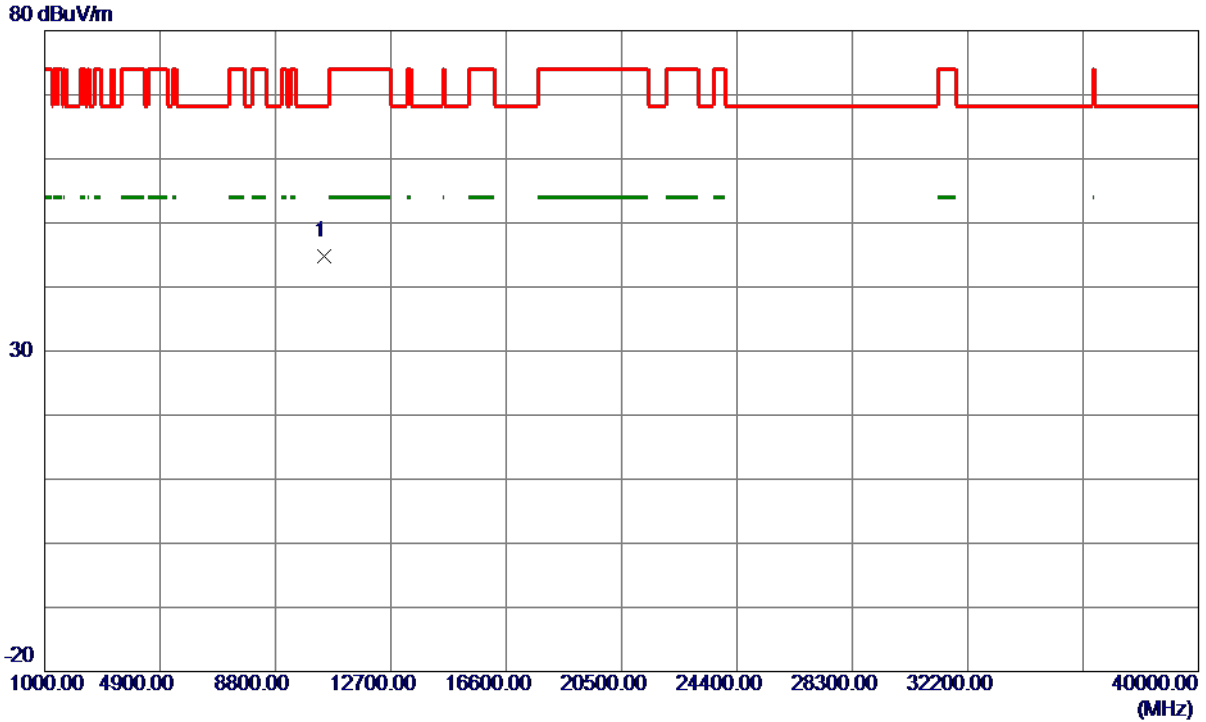

No.	Freq. MHz	Reading Level dBuV/m	Correct Factor dB	Measure ment dBuV/m	Limit dBuV/m	Margin dB	Detector	Comment
1 *	10455.9400	35.65	9.08	44.73	68.30	-23.57	Peak	

**REMARKS:**

- (1) Measurement Value = Reading Level + Correct Factor.
- (2) Margin Level = Measurement Value - Limit Value.

Orthogonal Axis	X
Test Mode	UNII-1_TX AC (VHT80) Mode 5210 MHz

### Vertical

130 dBuV/m

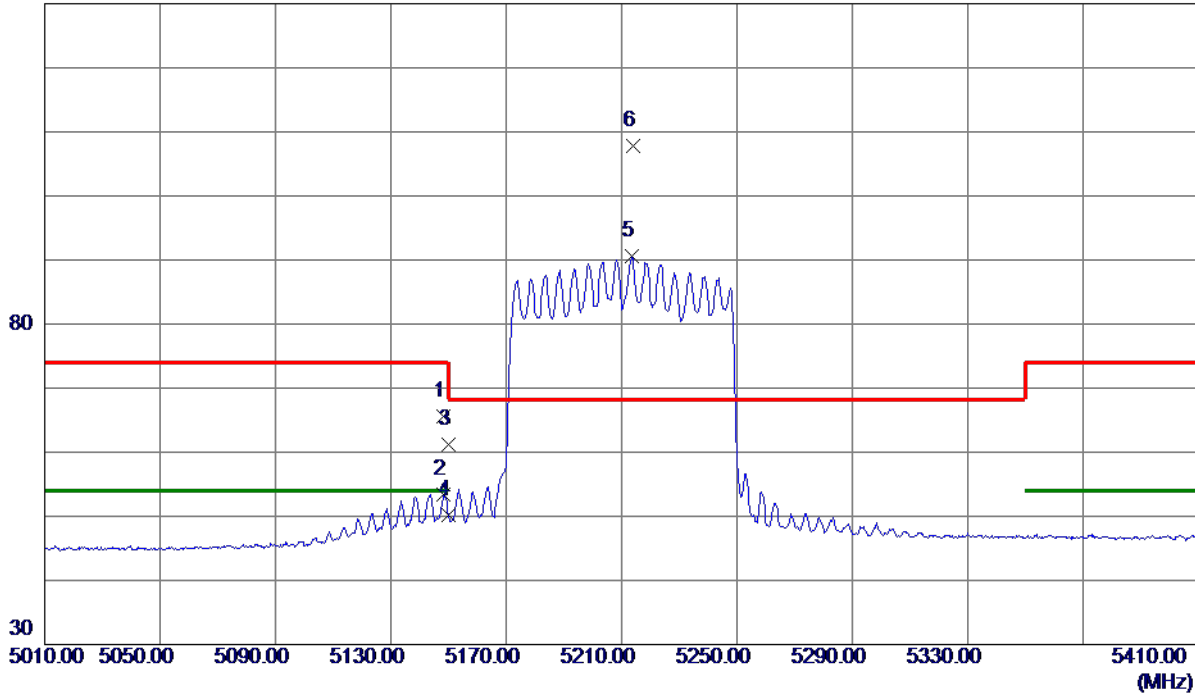

No.	Freq. MHz	Reading Level dBuV/m	Correct Factor dB	Measurement dBuV/m	Limit dBuV/m	Margin dB	Detector	Comment
1	5148.4000	49.98	15.68	65.66	74.00	-8.34	Peak	
2	5148.4000	37.78	15.68	53.46	54.00	-0.54	AVG	
3	5150.0000	45.48	15.68	61.16	74.00	-12.84	Peak	
4	5150.0000	34.59	15.68	50.27	54.00	-3.73	AVG	
5	5213.4000	74.81	15.72	90.53	999.00	-908.47	AVG	No Limit
6 *	5213.8000	92.16	15.72	107.88	68.30	39.58	Peak	No Limit

**REMARKS:**

- (1) Measurement Value = Reading Level + Correct Factor.
- (2) Margin Level = Measurement Value - Limit Value.

Orthogonal Axis	X
Test Mode	UNII-1_TX AC (VHT80) Mode 5210 MHz

### Vertical

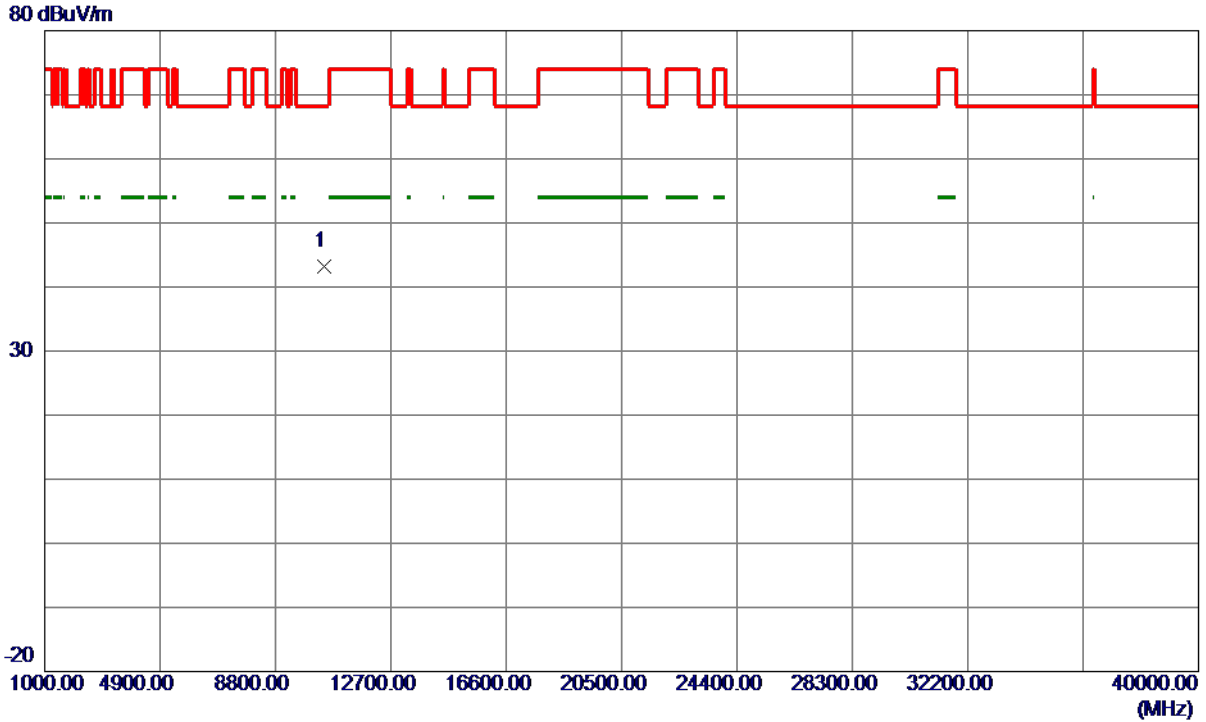

No.	Freq. MHz	Reading Level dBuV/m	Correct Factor dB	Measure ment dBuV/m	Limit dBuV/m	Margin dB	Detector	Comment
1 *	10427.8600	34.26	9.02	43.28	68.30	-25.02	Peak	

**REMARKS:**

- (1) Measurement Value = Reading Level + Correct Factor.
- (2) Margin Level = Measurement Value - Limit Value.



Orthogonal Axis	X
Test Mode	UNII-1_TX AC (VHT80) Mode 5210 MHz

### Horizontal

130 dBuV/m

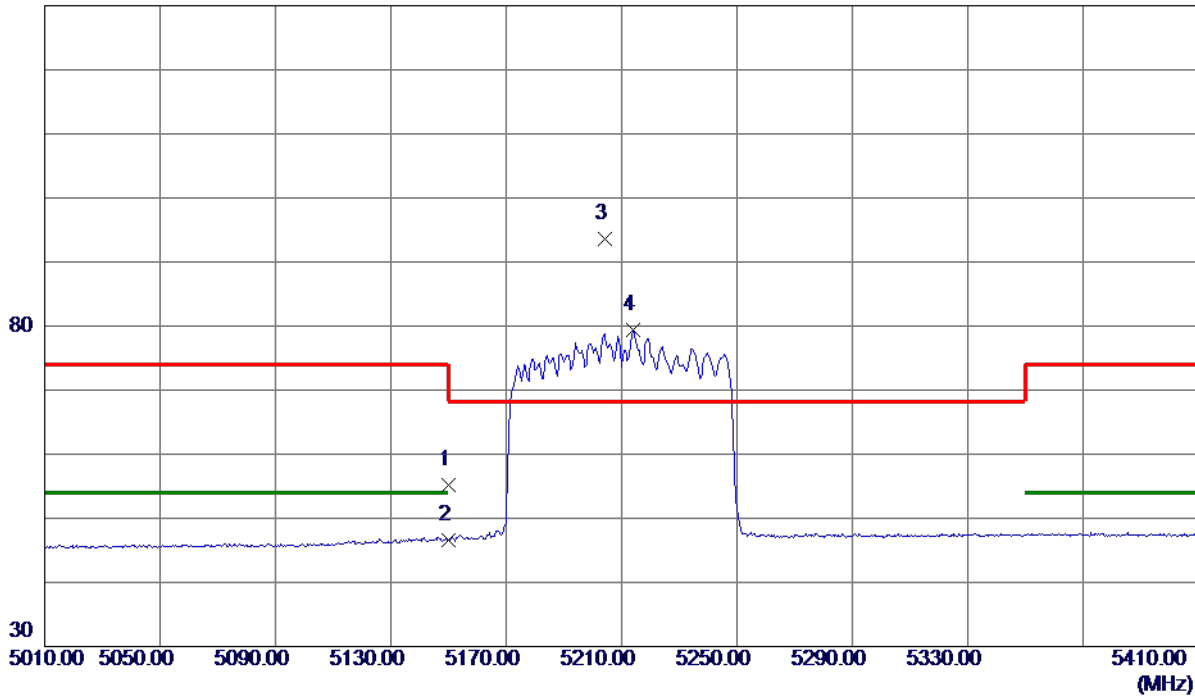

No.	Freq. MHz	Reading Level dBuV/m	Correct Factor dB	Measure ment dBuV/m	Limit dBuV/m	Margin dB	Detector	Comment
1	5150.0000	39.48	15.68	55.16	74.00	-18.84	Peak	
2	5150.0000	31.01	15.68	46.69	54.00	-7.31	AVG	
3 *	5204.4000	77.85	15.71	93.56	68.30	25.26	Peak	No Limit
4	5213.8000	63.65	15.72	79.37	999.00	-919.63	AVG	No Limit

**REMARKS:**

- (1) Measurement Value = Reading Level + Correct Factor.
- (2) Margin Level = Measurement Value - Limit Value.

Orthogonal Axis	X
Test Mode	UNII-1_TX AC (VHT80) Mode 5210 MHz

### Horizontal

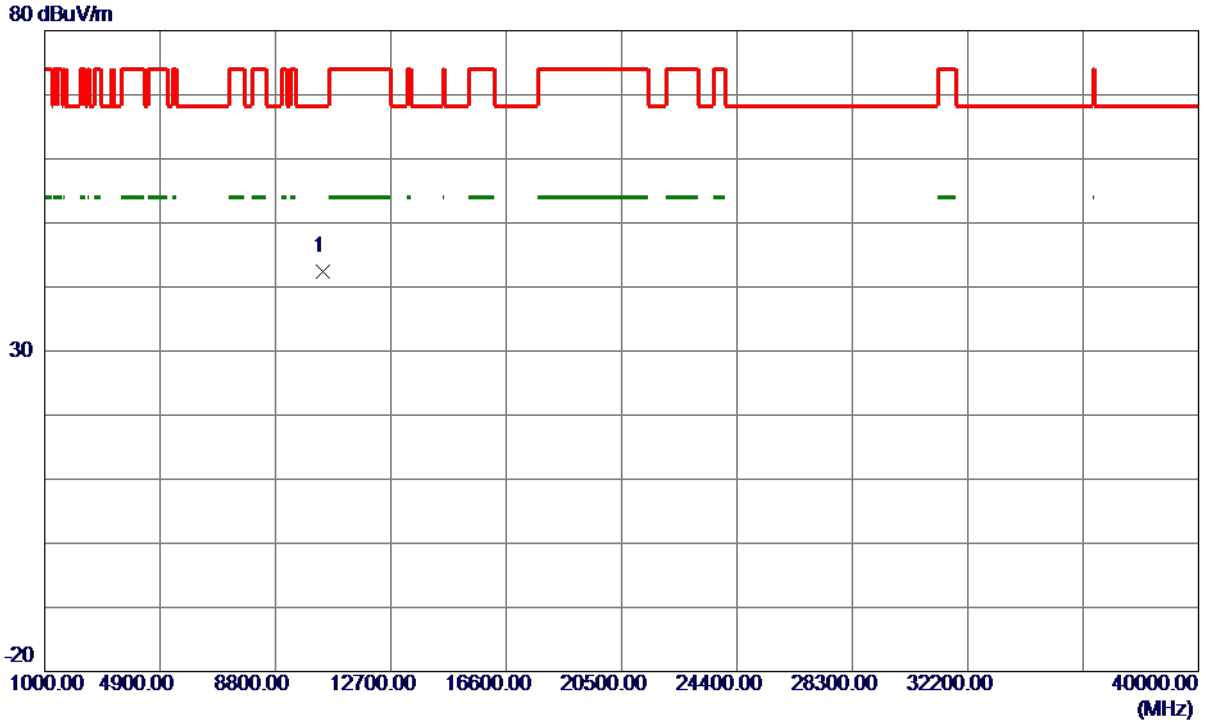

No.	Freq. MHz	Reading Level dBuV/m	Correct Factor dB	Measure ment dBuV/m	Limit dBuV/m	Margin dB	Detector	Comment
1 *	10412.7600	33.39	9.00	42.39	68.30	-25.91	Peak	

**REMARKS:**

- (1) Measurement Value = Reading Level + Correct Factor.
- (2) Margin Level = Measurement Value - Limit Value.

Orthogonal Axis	X
Test Mode	UNII-3_TX AC (VHT20) Mode 5745 MHz

### Vertical

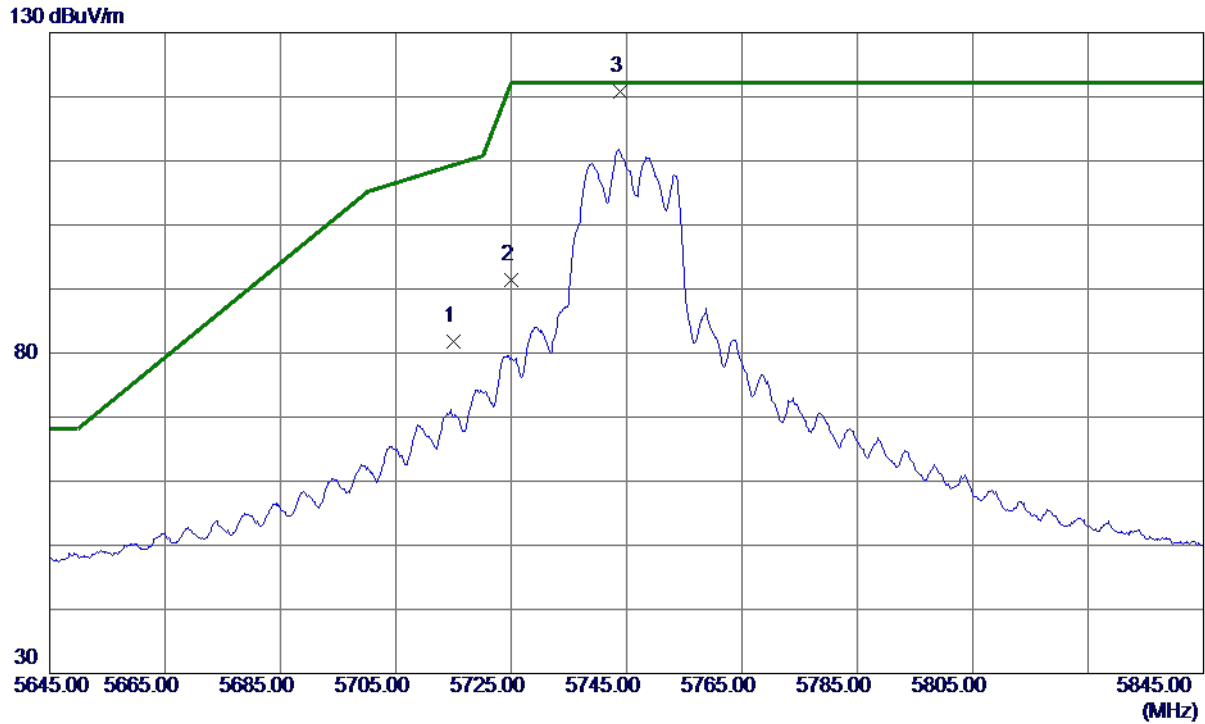

No.	Freq. MHz	Reading Level dBuV/m	Correct Factor dB	Measure ment dBuV/m	Limit dBuV/m	Margin dB	Detector	Comment
1	5715.0000	65.73	15.99	81.72	109.40	-27.68	Peak	
2	5725.0000	75.31	16.00	91.31	122.20	-30.89	Peak	
3 *	5743.8000	104.70	16.01	120.71	122.20	-1.49	Peak	No Limit

**REMARKS:**

- (1) Measurement Value = Reading Level + Correct Factor.
- (2) Margin Level = Measurement Value - Limit Value.

Orthogonal Axis	X
Test Mode	UNII-3_TX AC (VHT20) Mode 5745 MHz

### Vertical

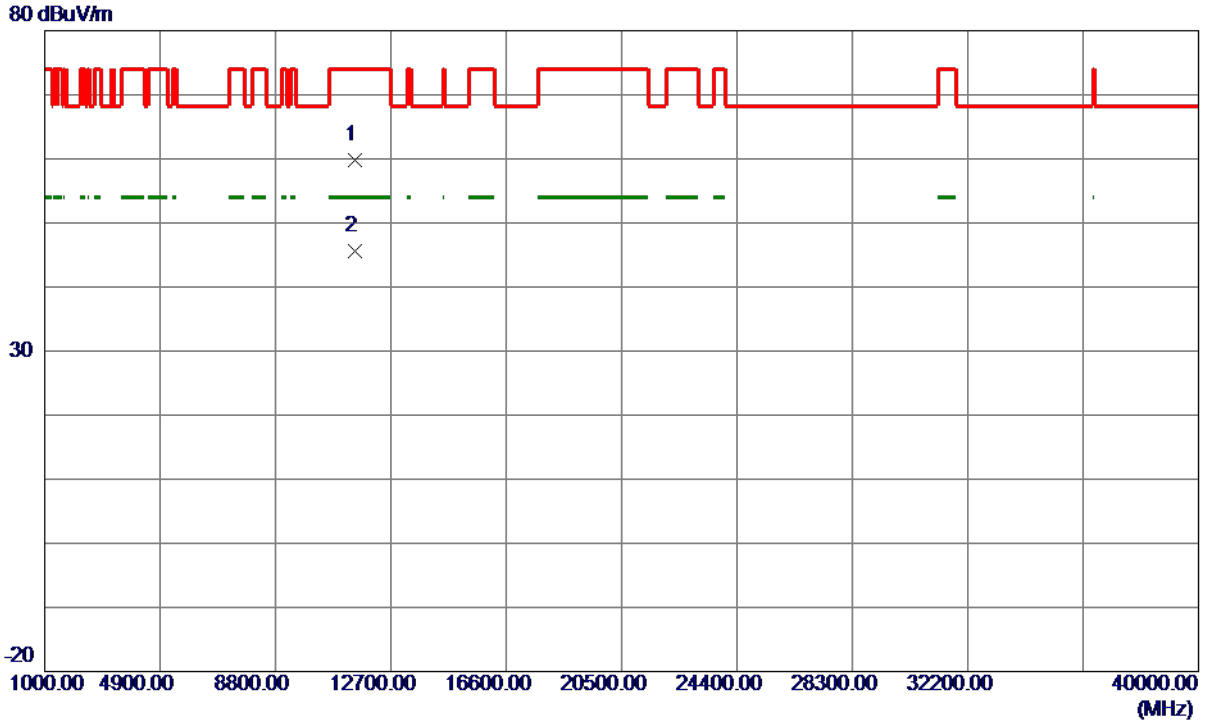

No.	Freq. MHz	Reading Level dBuV/m	Correct Factor dB	Measure ment dBuV/m	Limit dBuV/m	Margin dB	Detector	Comment
1	11491.1200	49.06	10.71	59.77	74.00	-14.23	Peak	
2 *	11491.3400	34.92	10.71	45.63	54.00	-8.37	AVG	

**REMARKS:**

- (1) Measurement Value = Reading Level + Correct Factor.
- (2) Margin Level = Measurement Value - Limit Value.

Orthogonal Axis	X
Test Mode	UNII-3_TX AC (VHT20) Mode 5745 MHz

### Horizontal

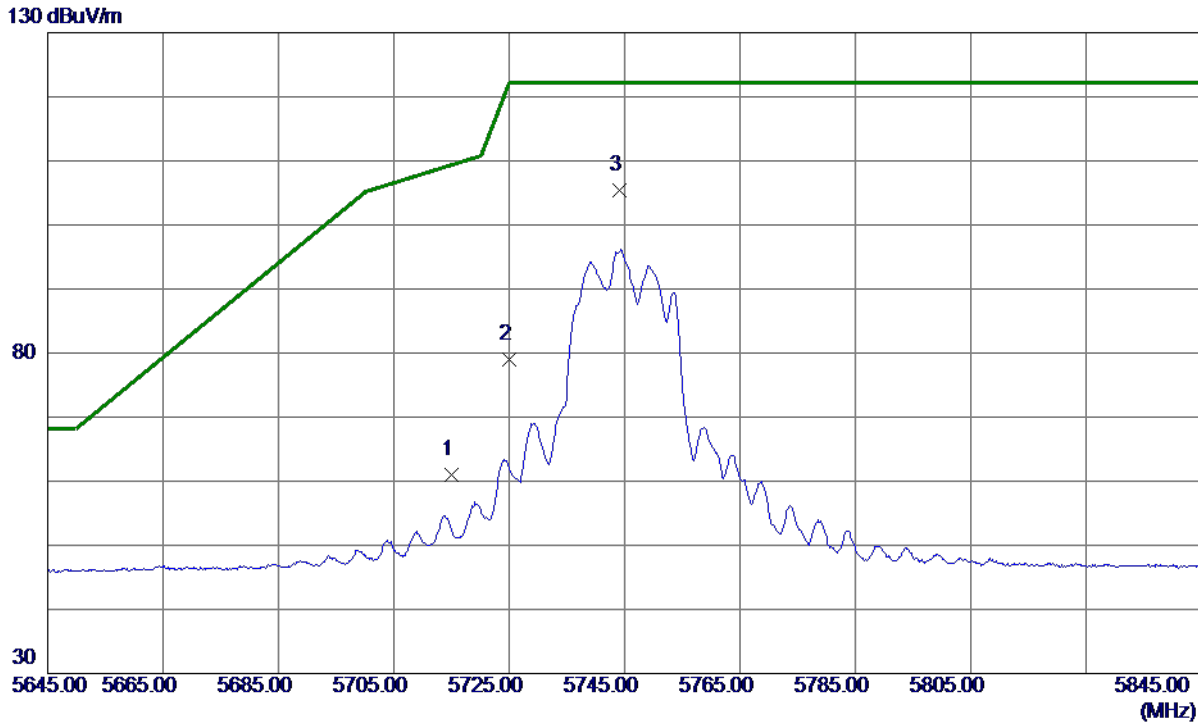

No.	Freq. MHz	Reading Level dBuV/m	Correct Factor dB	Measure ment dBuV/m	Limit dBuV/m	Margin dB	Detector	Comment
1	5715.0000	45.06	15.99	61.05	109.40	-48.35	Peak	
2	5725.0000	63.03	16.00	79.03	122.20	-43.17	Peak	
3 *	5744.1000	89.44	16.01	105.45	122.20	-16.75	Peak	No Limit

**REMARKS:**

- (1) Measurement Value = Reading Level + Correct Factor.
- (2) Margin Level = Measurement Value - Limit Value.

Orthogonal Axis	X
Test Mode	UNII-3_TX AC (VHT20) Mode 5745 MHz

### Horizontal

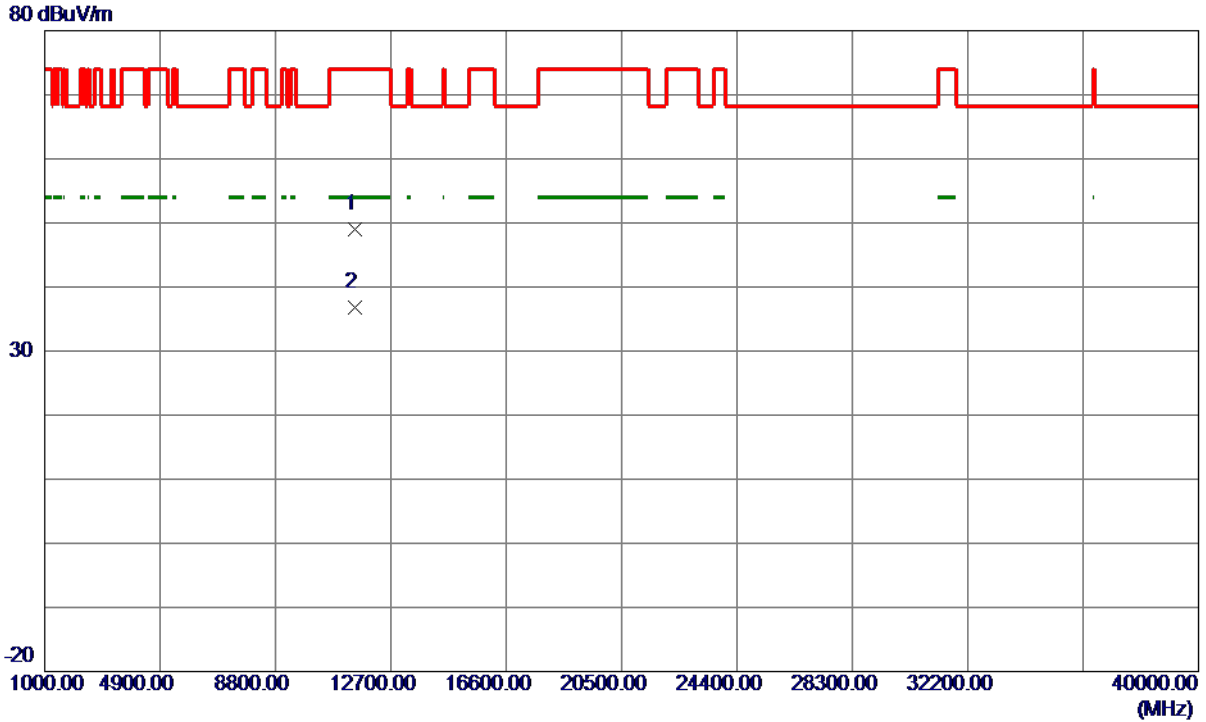

No.	Freq. MHz	Reading Level dBuV/m	Correct Factor dB	Measure ment dBuV/m	Limit dBuV/m	Margin dB	Detector	Comment
1	11486.5400	38.30	10.70	49.00	74.00	-25.00	Peak	
2 *	11491.8200	26.16	10.71	36.87	54.00	-17.13	AVG	

**REMARKS:**

- (1) Measurement Value = Reading Level + Correct Factor.
- (2) Margin Level = Measurement Value - Limit Value.

Orthogonal Axis	X
Test Mode	UNII-3_TX AC (VHT20) Mode 5785 MHz

### Vertical

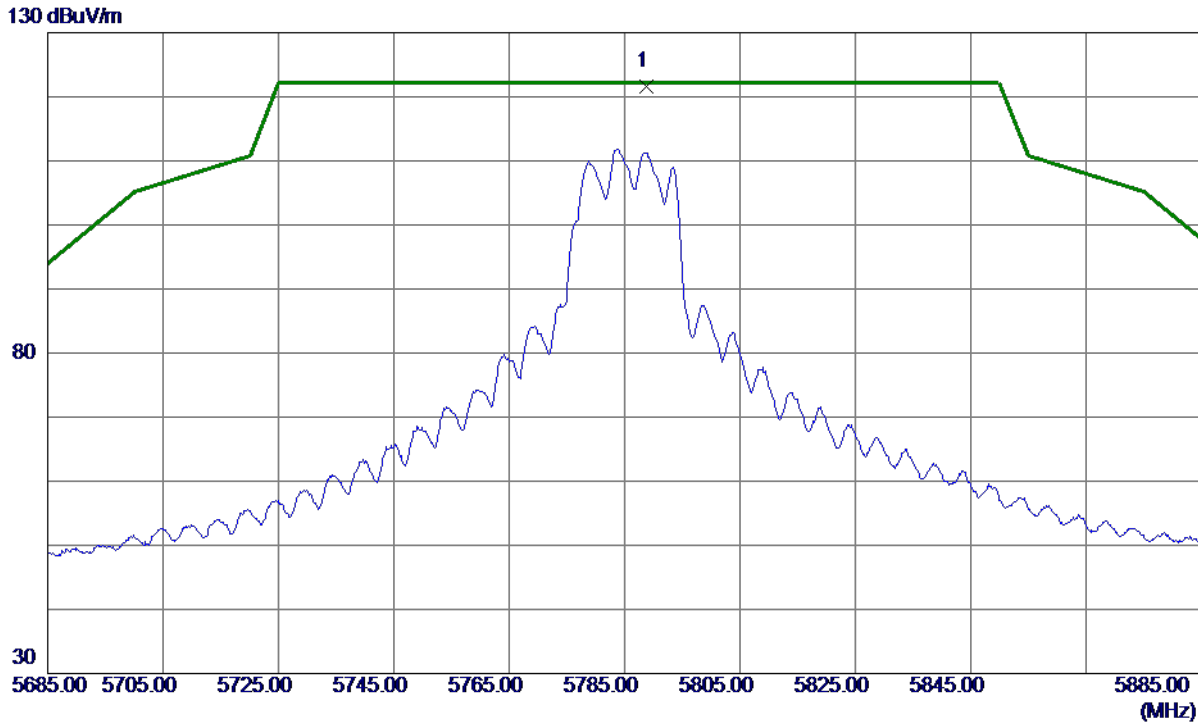

No.	Freq. MHz	Reading Level dBuV/m	Correct Factor dB	Measure ment dBuV/m	Limit dBuV/m	Margin dB	Detector	Comment
1 *	5788.7000	105.53	16.04	121.57	122.20	-0.63	Peak	No Limit

**REMARKS:**

- (1) Measurement Value = Reading Level + Correct Factor.
- (2) Margin Level = Measurement Value - Limit Value.

Orthogonal Axis	X
Test Mode	UNII-3_TX AC (VHT20) Mode 5785 MHz

### Vertical

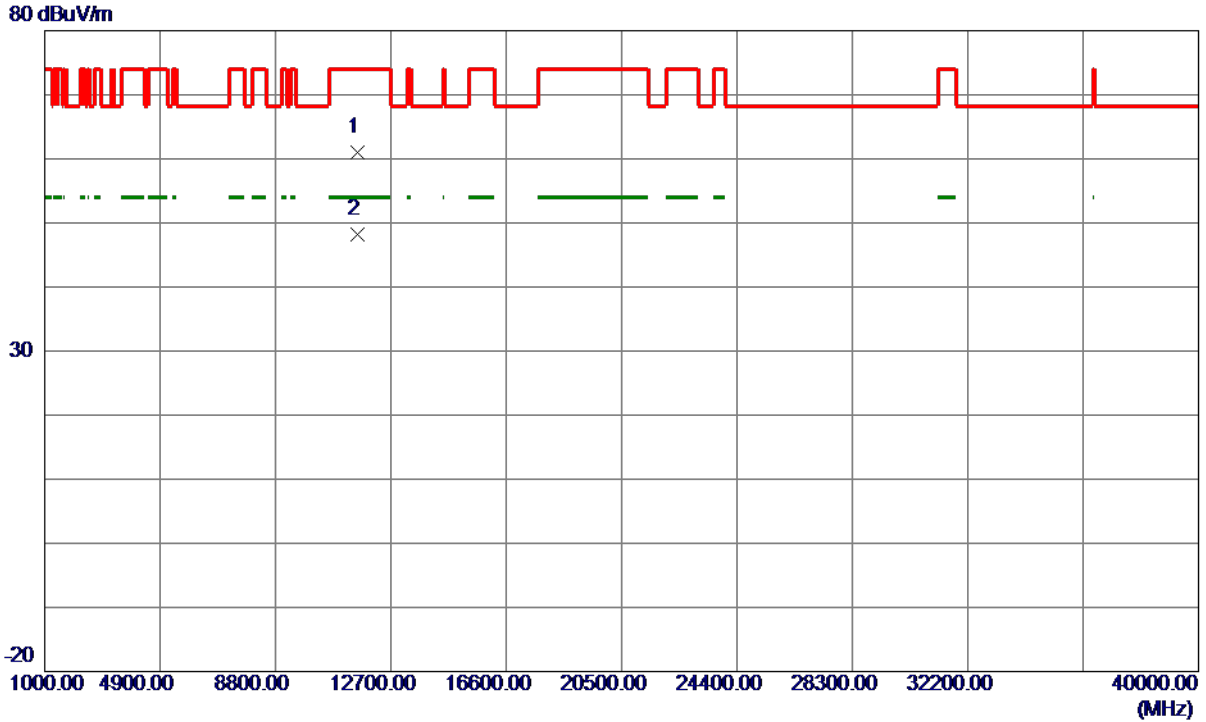

No.	Freq. MHz	Reading Level dBuV/m	Correct Factor dB	Measure ment dBuV/m	Limit dBuV/m	Margin dB	Detector	Comment
1	11560.9200	50.15	10.85	61.00	74.00	-13.00	Peak	
2 *	11566.0199	37.27	10.86	48.13	54.00	-5.87	AVG	

**REMARKS:**

- (1) Measurement Value = Reading Level + Correct Factor.
- (2) Margin Level = Measurement Value - Limit Value.



Orthogonal Axis	X
Test Mode	UNII-3_TX AC (VHT20) Mode 5785 MHz

### Horizontal

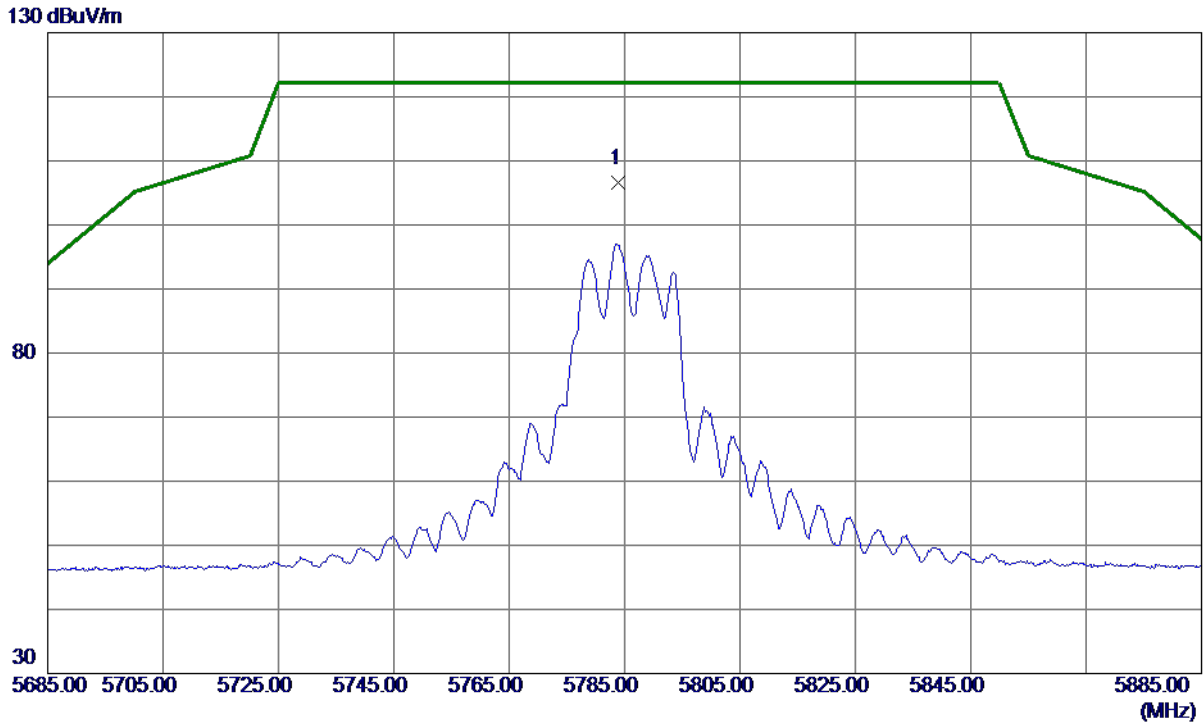

No.	Freq. MHz	Reading Level dBuV/m	Correct Factor dB	Measure ment dBuV/m	Limit dBuV/m	Margin dB	Detector	Comment
1 *	5784.0000	90.46	16.04	106.50	122.20	-15.70	Peak	No Limit

**REMARKS:**

- (1) Measurement Value = Reading Level + Correct Factor.
- (2) Margin Level = Measurement Value - Limit Value.

Orthogonal Axis	X
Test Mode	UNII-3_TX AC (VHT20) Mode 5785 MHz

### Horizontal

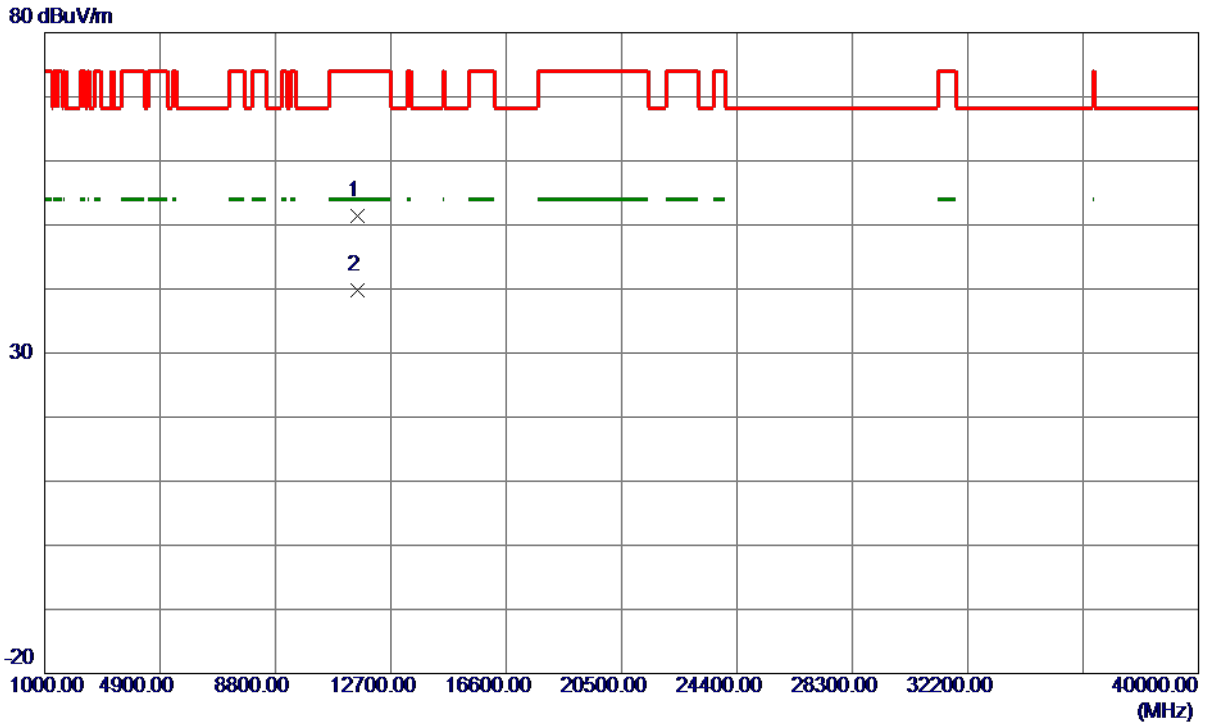

No.	Freq. MHz	Reading Level dBuV/m	Correct Factor dB	Measure ment dBuV/m	Limit dBuV/m	Margin dB	Detector	Comment
1	11575.0400	40.47	10.87	51.34	74.00	-22.66	Peak	
2 *	11575.0599	28.92	10.87	39.79	54.00	-14.21	AVG	

**REMARKS:**

- (1) Measurement Value = Reading Level + Correct Factor.
- (2) Margin Level = Measurement Value - Limit Value.

Orthogonal Axis	X
Test Mode	UNII-3_TX AC (VHT20) Mode 5825 MHz

### Vertical

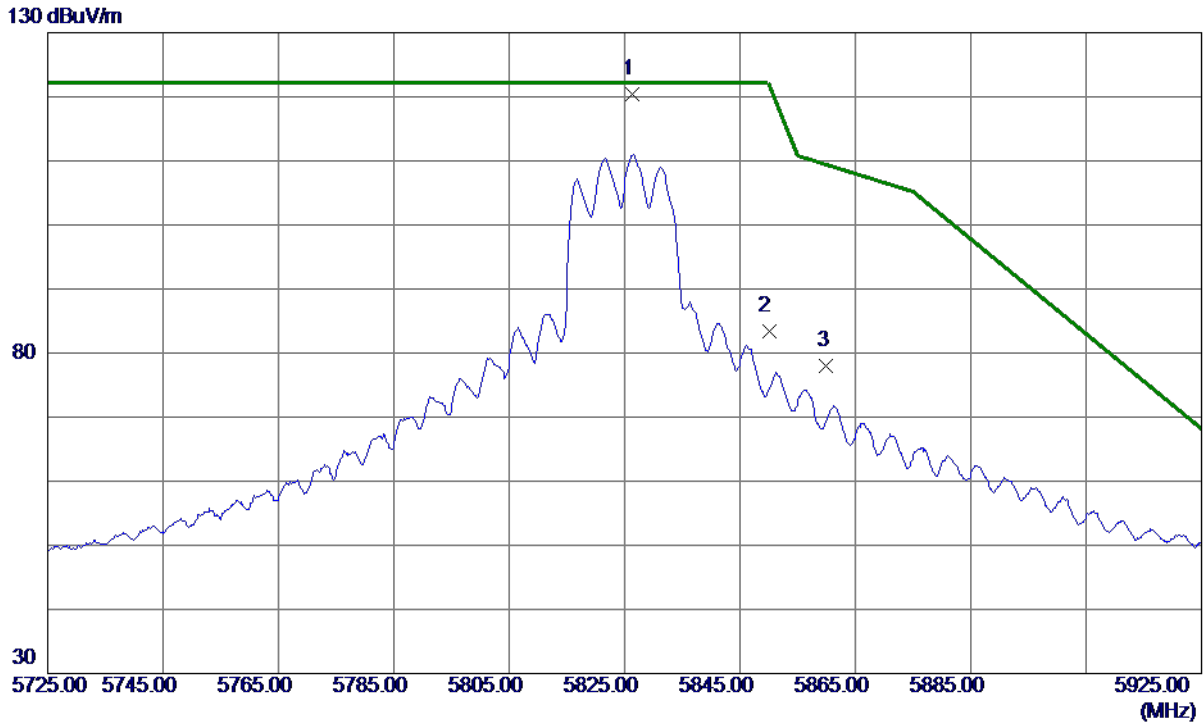

No.	Freq. MHz	Reading Level dBuV/m	Correct Factor dB	Measure ment dBuV/m	Limit dBuV/m	Margin dB	Detector	Comment
1 *	5826.3000	104.27	16.06	120.33	122.20	-1.87	Peak	No Limit
2	5850.0000	67.30	16.08	83.38	122.20	-38.82	Peak	
3	5860.0000	61.91	16.08	77.99	109.40	-31.41	Peak	

**REMARKS:**

- (1) Measurement Value = Reading Level + Correct Factor.
- (2) Margin Level = Measurement Value - Limit Value.

Orthogonal Axis	X
Test Mode	UNII-3_TX AC (VHT20) Mode 5825 MHz

### Vertical

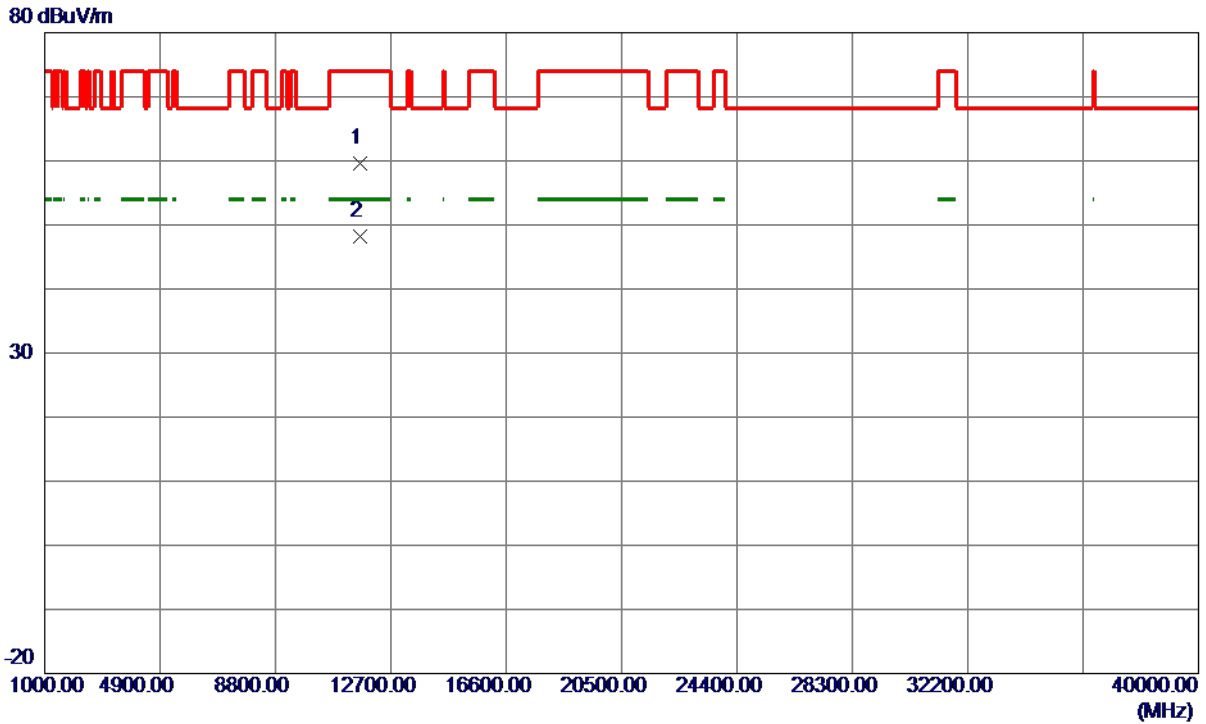

No.	Freq. MHz	Reading Level dBuV/m	Correct Factor dB	Measure ment dBuV/m	Limit dBuV/m	Margin dB	Detector	Comment
1	11646.8200	48.55	11.01	59.56	74.00	-14.44	Peak	
2 *	11651.8600	37.21	11.02	48.23	54.00	-5.77	AVG	

**REMARKS:**

- (1) Measurement Value = Reading Level + Correct Factor.
- (2) Margin Level = Measurement Value - Limit Value.

Orthogonal Axis	X
Test Mode	UNII-3_TX AC (VHT20) Mode 5825 MHz

### Horizontal

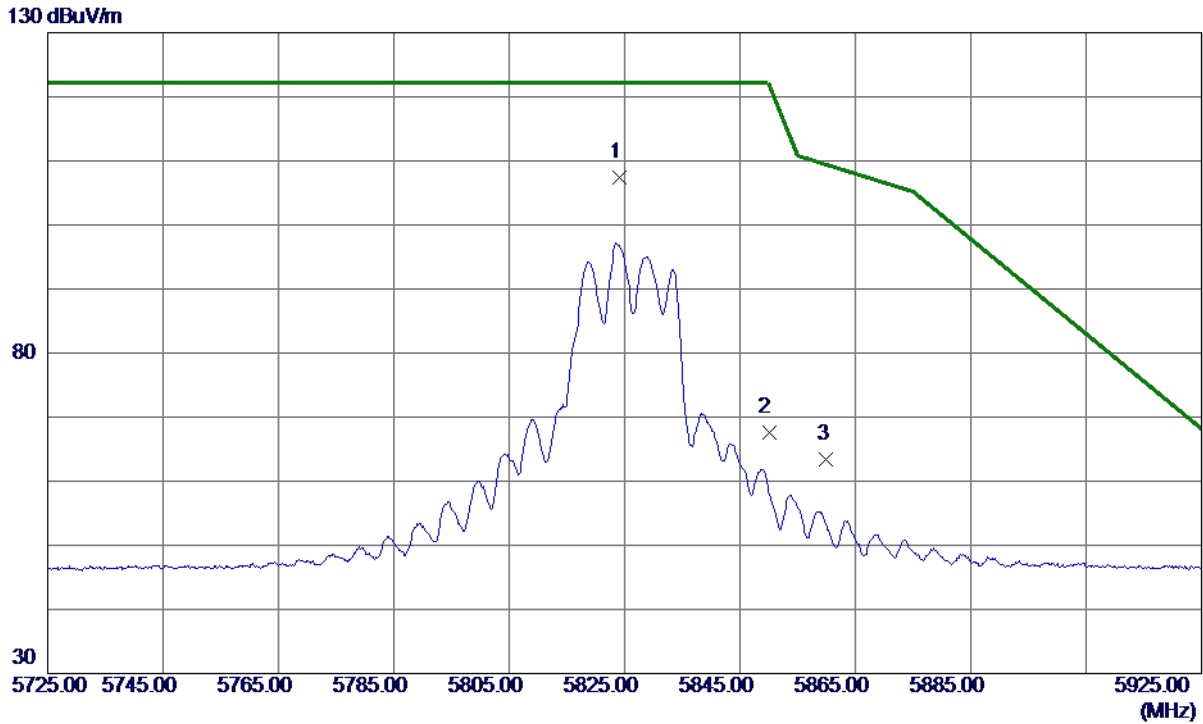

No.	Freq. MHz	Reading Level dBuV/m	Correct Factor dB	Measure ment dBuV/m	Limit dBuV/m	Margin dB	Detector	Comment
1 *	5824.1000	91.30	16.06	107.36	122.20	-14.84	Peak	No Limit
2	5850.0000	51.50	16.08	67.58	122.20	-54.62	Peak	
3	5860.0000	47.26	16.08	63.34	109.40	-46.06	Peak	

**REMARKS:**

- (1) Measurement Value = Reading Level + Correct Factor.
- (2) Margin Level = Measurement Value - Limit Value.

Orthogonal Axis	X
Test Mode	UNII-3_TX AC (VHT20) Mode 5825 MHz

### Horizontal

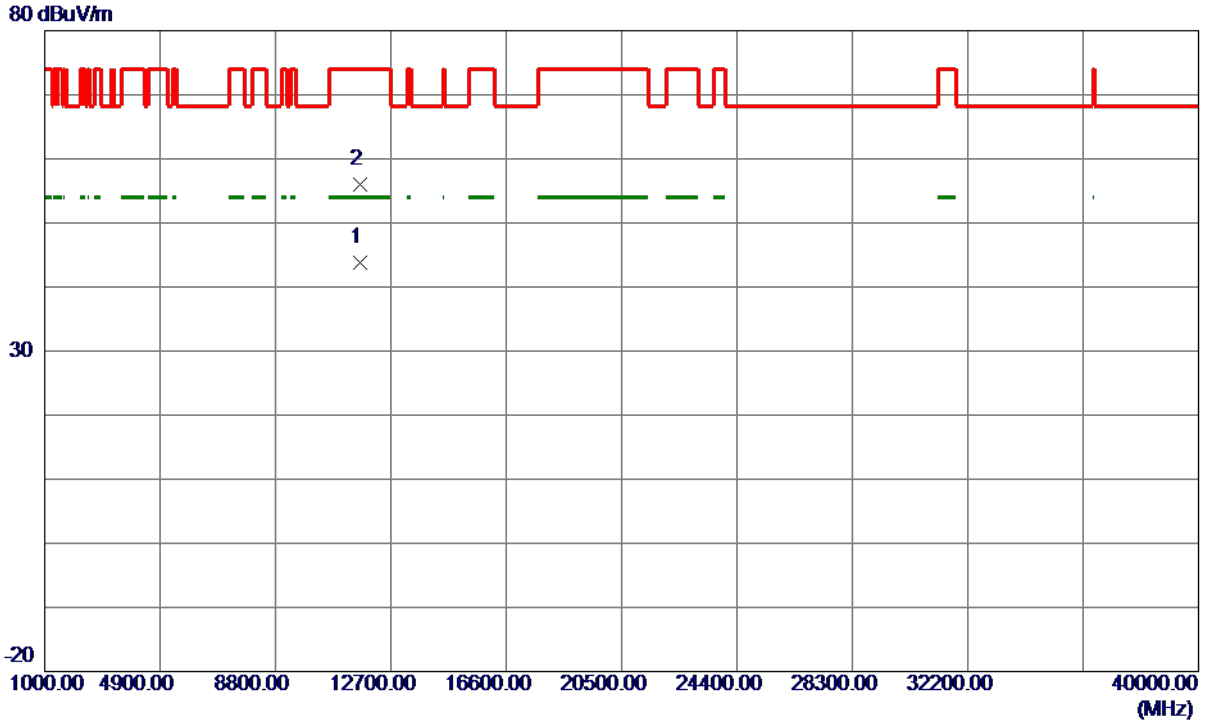

No.	Freq. MHz	Reading Level dBuV/m	Correct Factor dB	Measure ment dBuV/m	Limit dBuV/m	Margin dB	Detector	Comment
1 *	11650.1600	32.70	11.02	43.72	54.00	-10.28	AVG	
2	11651.0000	44.90	11.02	55.92	74.00	-18.08	Peak	

**REMARKS:**

- (1) Measurement Value = Reading Level + Correct Factor.
- (2) Margin Level = Measurement Value - Limit Value.

Orthogonal Axis	X
Test Mode	UNII-3_TX AC (VHT40) Mode 5755 MHz

### Vertical

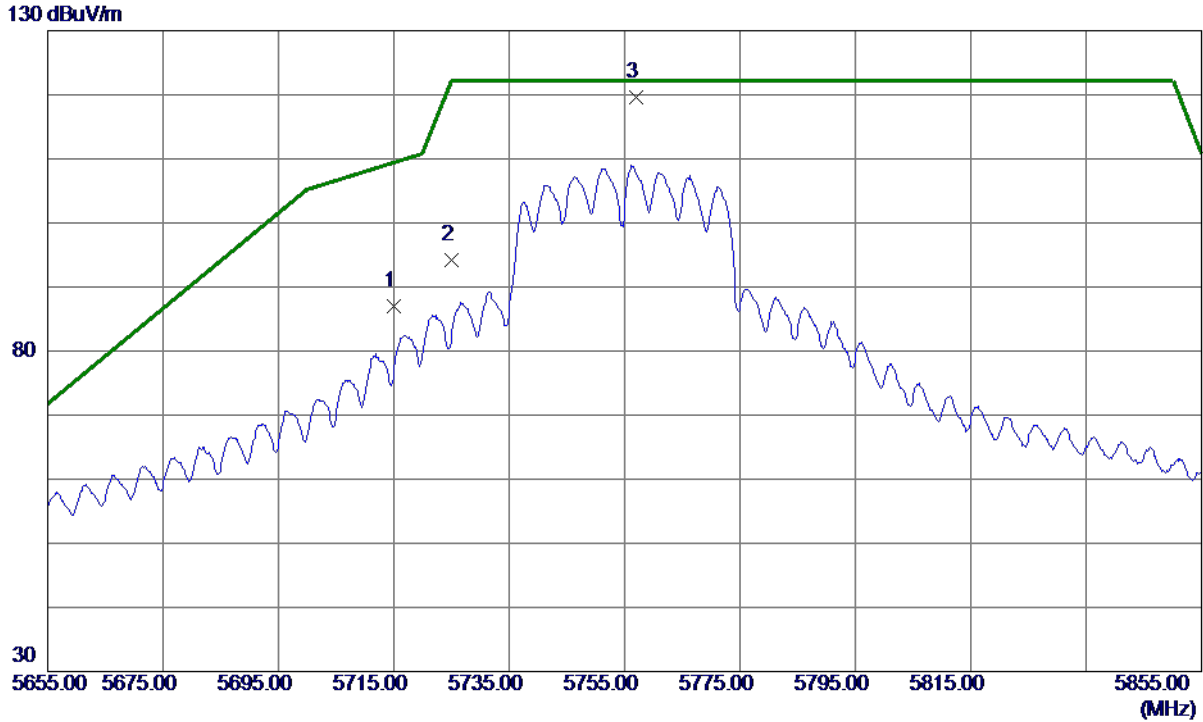

No.	Freq. MHz	Reading Level dBuV/m	Correct Factor dB	Measure ment dBuV/m	Limit dBuV/m	Margin dB	Detector	Comment
1	5715.0000	71.11	15.99	87.10	109.40	-22.30	Peak	
2	5725.0000	78.16	16.00	94.16	122.20	-28.04	Peak	
3 *	5757.0000	103.62	16.02	119.64	122.20	-2.56	Peak	No Limit

**REMARKS:**

- (1) Measurement Value = Reading Level + Correct Factor.
- (2) Margin Level = Measurement Value - Limit Value.

Orthogonal Axis	X
Test Mode	UNII-3_TX AC (VHT40) Mode 5755 MHz

### Vertical

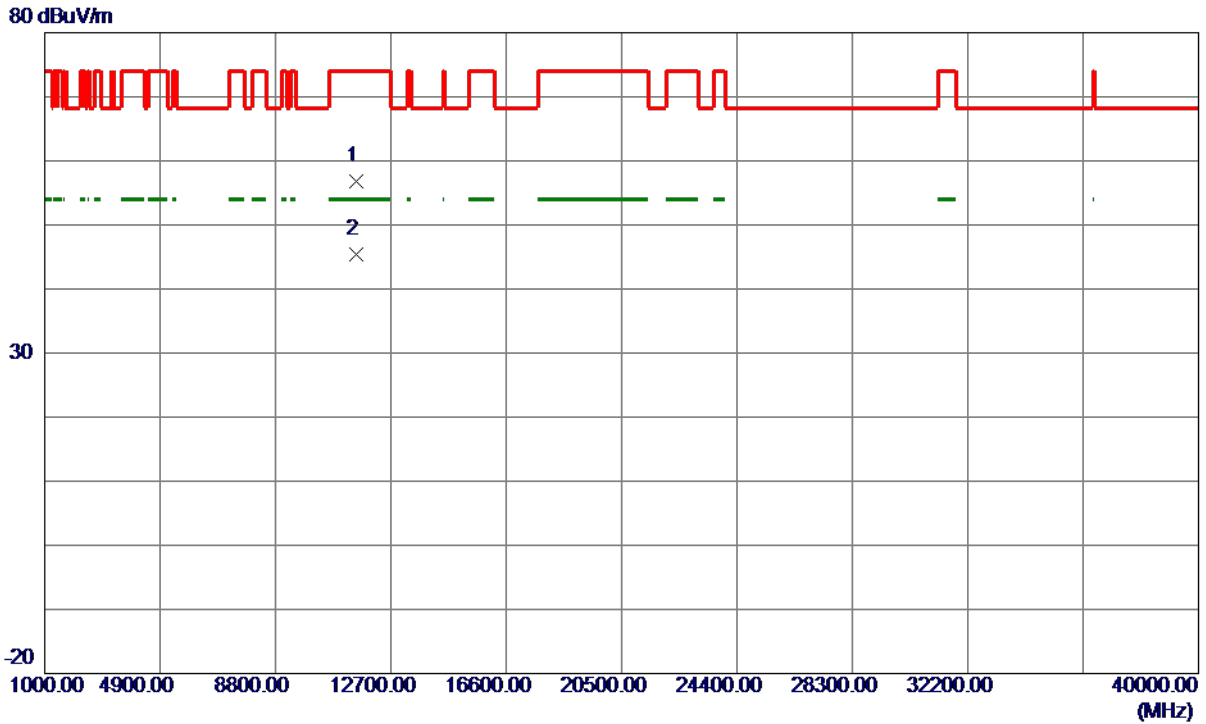

No.	Freq. MHz	Reading Level dBuV/m	Correct Factor dB	Measure ment dBuV/m	Limit dBuV/m	Margin dB	Detector	Comment
1	11509.9400	46.13	10.75	56.88	74.00	-17.12	Peak	
2 *	11510.6400	34.57	10.75	45.32	54.00	-8.68	AVG	

**REMARKS:**

- (1) Measurement Value = Reading Level + Correct Factor.
- (2) Margin Level = Measurement Value - Limit Value.



Orthogonal Axis	X
Test Mode	UNII-3_TX AC (VHT40) Mode 5755 MHz

### Horizontal

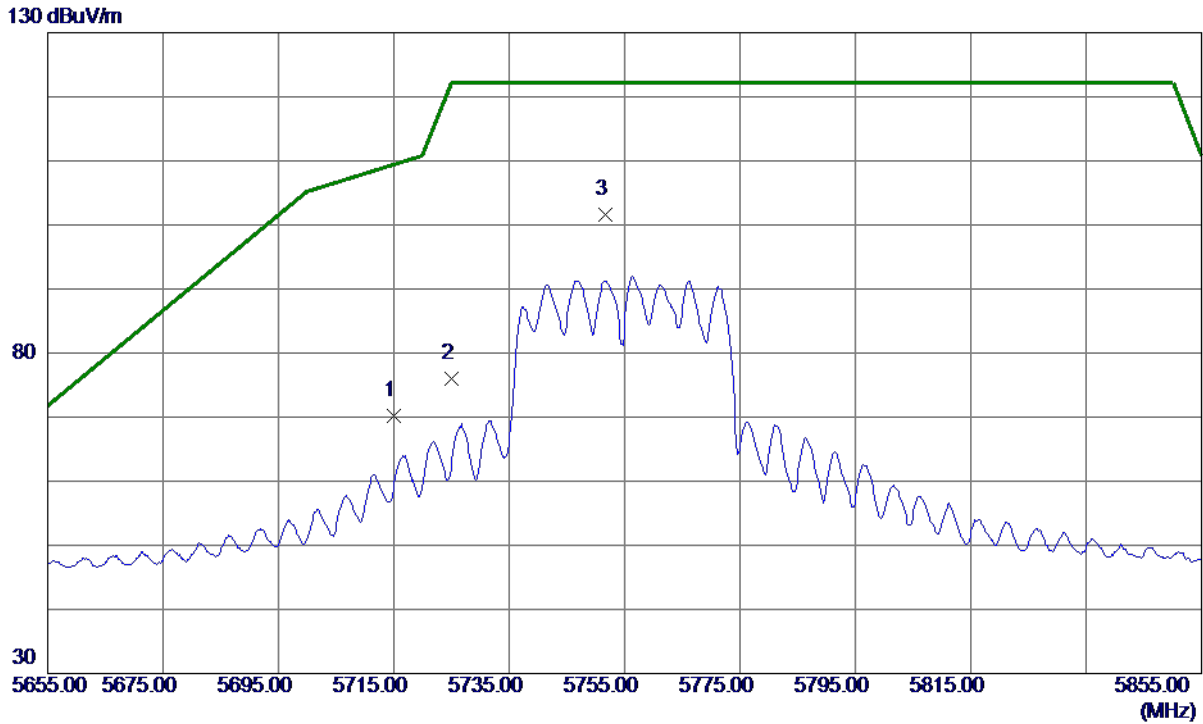

No.	Freq. MHz	Reading Level dBuV/m	Correct Factor dB	Measure ment dBuV/m	Limit dBuV/m	Margin dB	Detector	Comment
1	5715.0000	54.14	15.99	70.13	109.40	-39.27	Peak	
2	5725.0000	60.06	16.00	76.06	122.20	-46.14	Peak	
3 *	5751.7000	85.63	16.02	101.65	122.20	-20.55	Peak	No Limit

**REMARKS:**

- (1) Measurement Value = Reading Level + Correct Factor.
- (2) Margin Level = Measurement Value - Limit Value.

Orthogonal Axis	X
Test Mode	UNII-3_TX AC (VHT40) Mode 5755 MHz

### Horizontal

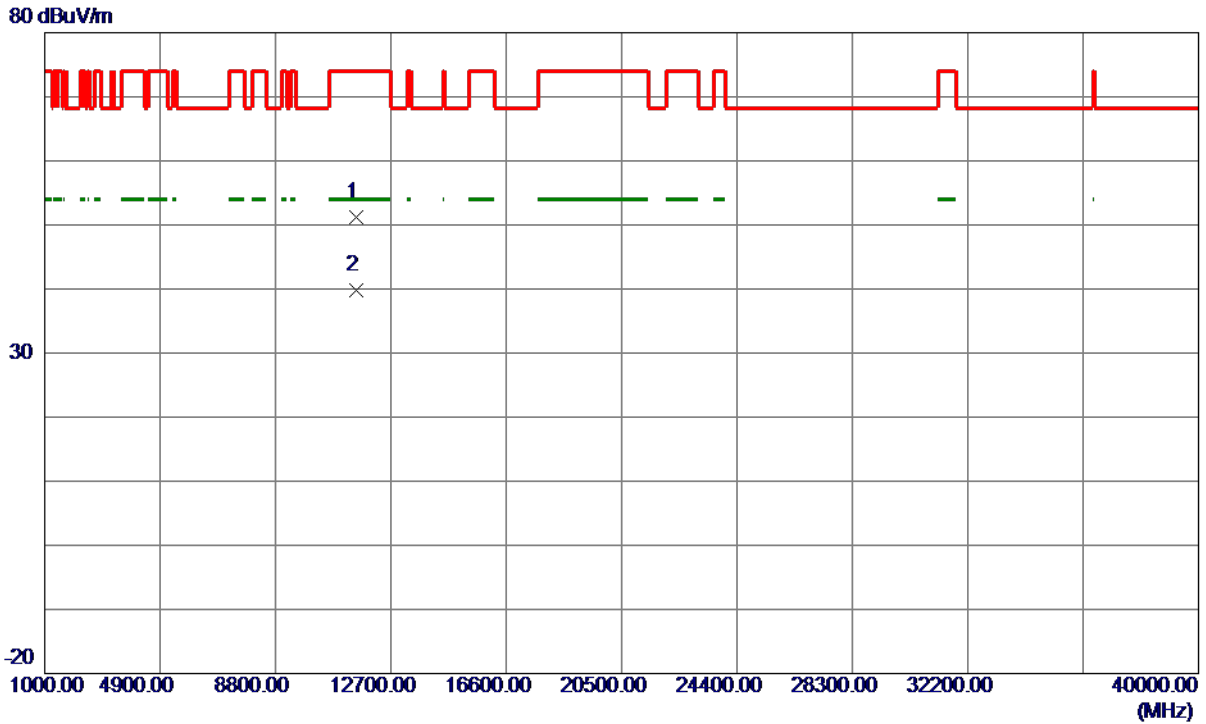

No.	Freq. MHz	Reading Level dBuV/m	Correct Factor dB	Measure ment dBuV/m	Limit dBuV/m	Margin dB	Detector	Comment
1	11511.1400	40.50	10.75	51.25	74.00	-22.75	Peak	
2 *	11511.8600	29.06	10.75	39.81	54.00	-14.19	AVG	

**REMARKS:**

- (1) Measurement Value = Reading Level + Correct Factor.
- (2) Margin Level = Measurement Value - Limit Value.

Orthogonal Axis	X
Test Mode	UNII-3_TX AC (VHT40) Mode 5795 MHz

### Vertical

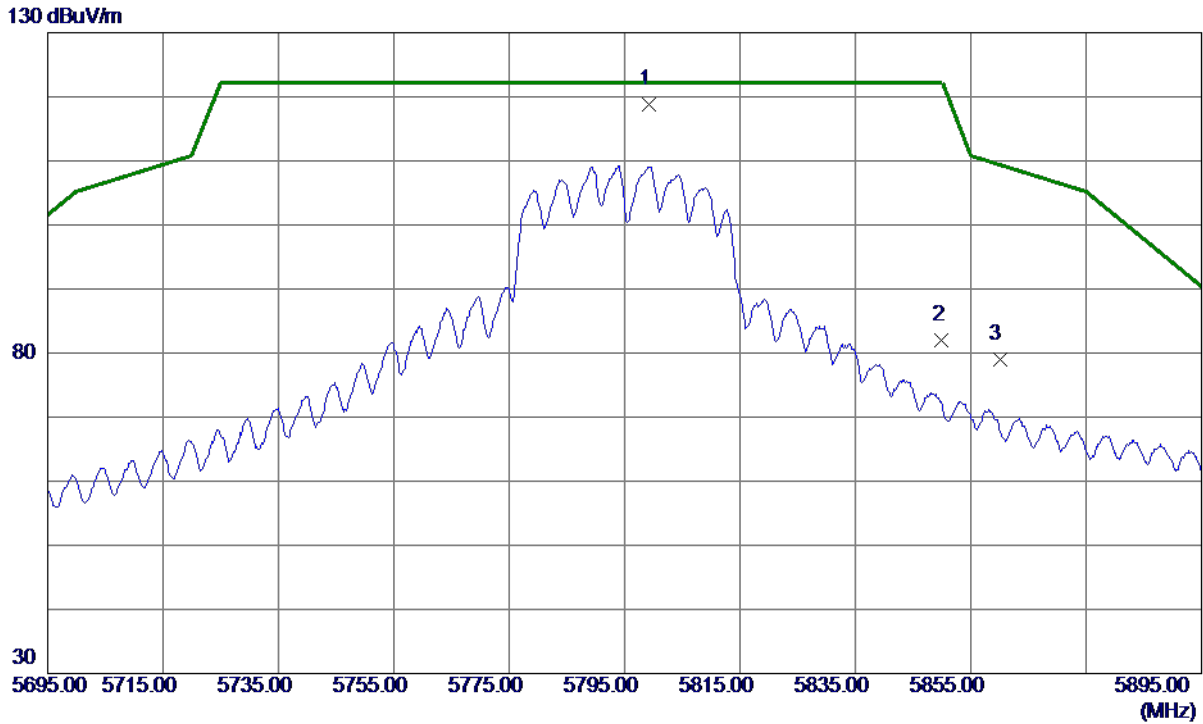

No.	Freq. MHz	Reading Level dBuV/m	Correct Factor dB	Measure ment dBuV/m	Limit dBuV/m	Margin dB	Detector	Comment
1 *	5799.3000	102.66	16.05	118.71	122.20	-3.49	Peak	No Limit
2	5850.0000	65.90	16.08	81.98	122.20	-40.22	Peak	
3	5860.0000	62.98	16.08	79.06	109.40	-30.34	Peak	

**REMARKS:**

- (1) Measurement Value = Reading Level + Correct Factor.
- (2) Margin Level = Measurement Value - Limit Value.

Orthogonal Axis	X
Test Mode	UNII-3_TX AC (VHT40) Mode 5795 MHz

### Vertical

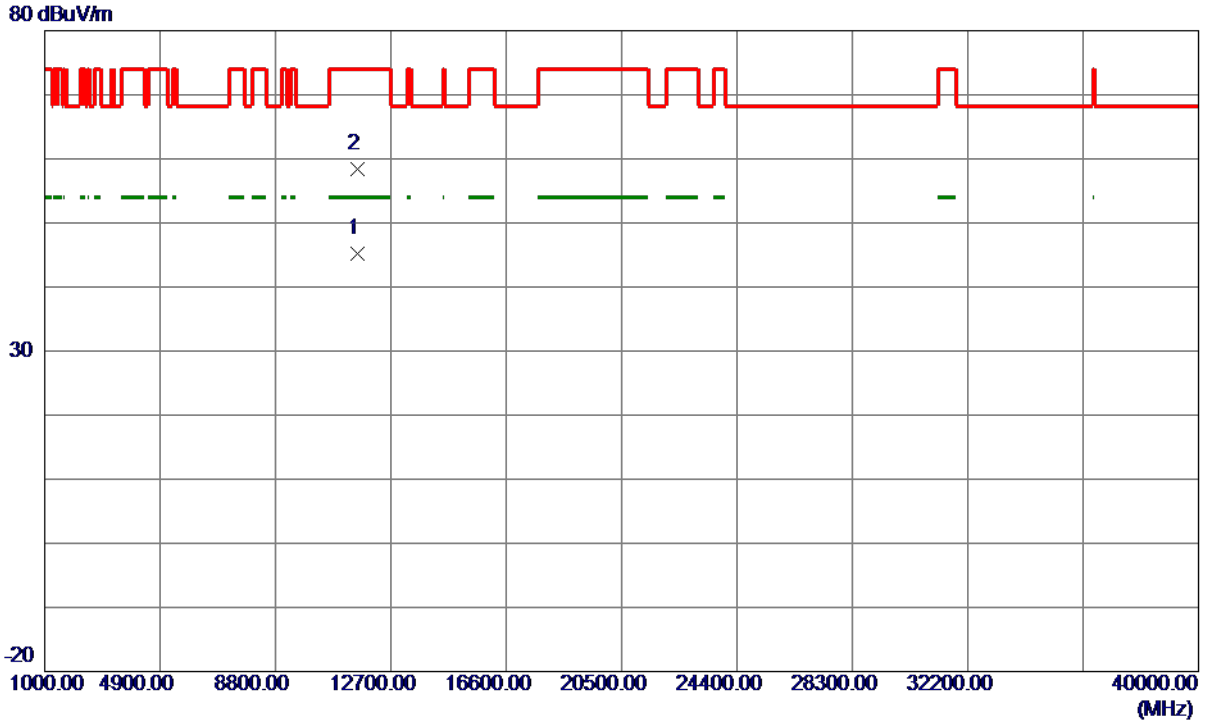

No.	Freq. MHz	Reading Level dBuV/m	Correct Factor dB	Measure ment dBuV/m	Limit dBuV/m	Margin dB	Detector	Comment
1 *	11581.8600	34.32	10.89	45.21	54.00	-8.79	AVG	
2	11588.2400	47.50	10.90	58.40	74.00	-15.60	Peak	

**REMARKS:**

- (1) Measurement Value = Reading Level + Correct Factor.
- (2) Margin Level = Measurement Value - Limit Value.

Orthogonal Axis	X
Test Mode	UNII-3_TX AC (VHT40) Mode 5795 MHz

### Horizontal

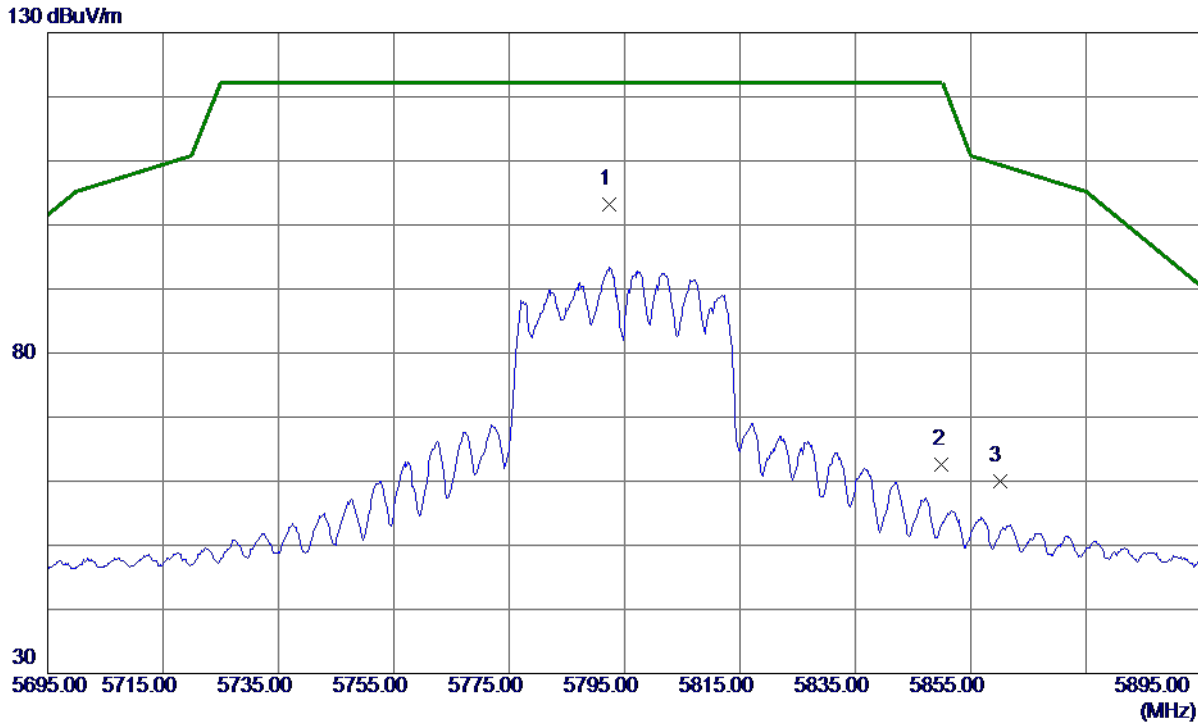

No.	Freq. MHz	Reading Level dBuV/m	Correct Factor dB	Measure ment dBuV/m	Limit dBuV/m	Margin dB	Detector	Comment
1 *	5792.3000	87.10	16.04	103.14	122.20	-19.06	Peak	No Limit
2	5850.0000	46.55	16.08	62.63	122.20	-59.57	Peak	
3	5860.0000	43.93	16.08	60.01	109.40	-49.39	Peak	

**REMARKS:**

- (1) Measurement Value = Reading Level + Correct Factor.
- (2) Margin Level = Measurement Value - Limit Value.

Orthogonal Axis	X
Test Mode	UNII-3_TX AC (VHT40) Mode 5795 MHz

### Horizontal

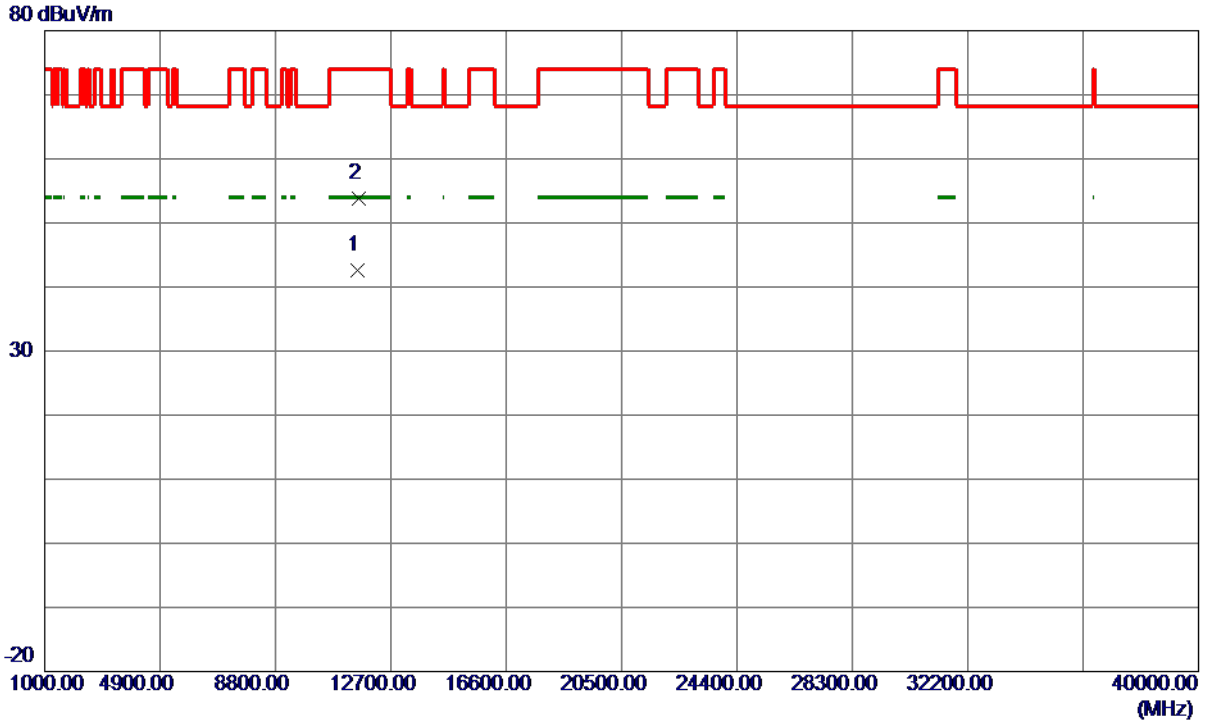

No.	Freq. MHz	Reading Level dBuV/m	Correct Factor dB	Measure ment dBuV/m	Limit dBuV/m	Margin dB	Detector	Comment
1 *	11589.4000	31.72	10.90	42.62	54.00	-11.38	AVG	
2	11598.7400	42.93	10.92	53.85	74.00	-20.15	Peak	

**REMARKS:**

- (1) Measurement Value = Reading Level + Correct Factor.
- (2) Margin Level = Measurement Value - Limit Value.

Orthogonal Axis	X
Test Mode	UNII-3_TX AC (VHT80) Mode 5775 MHz

### Vertical

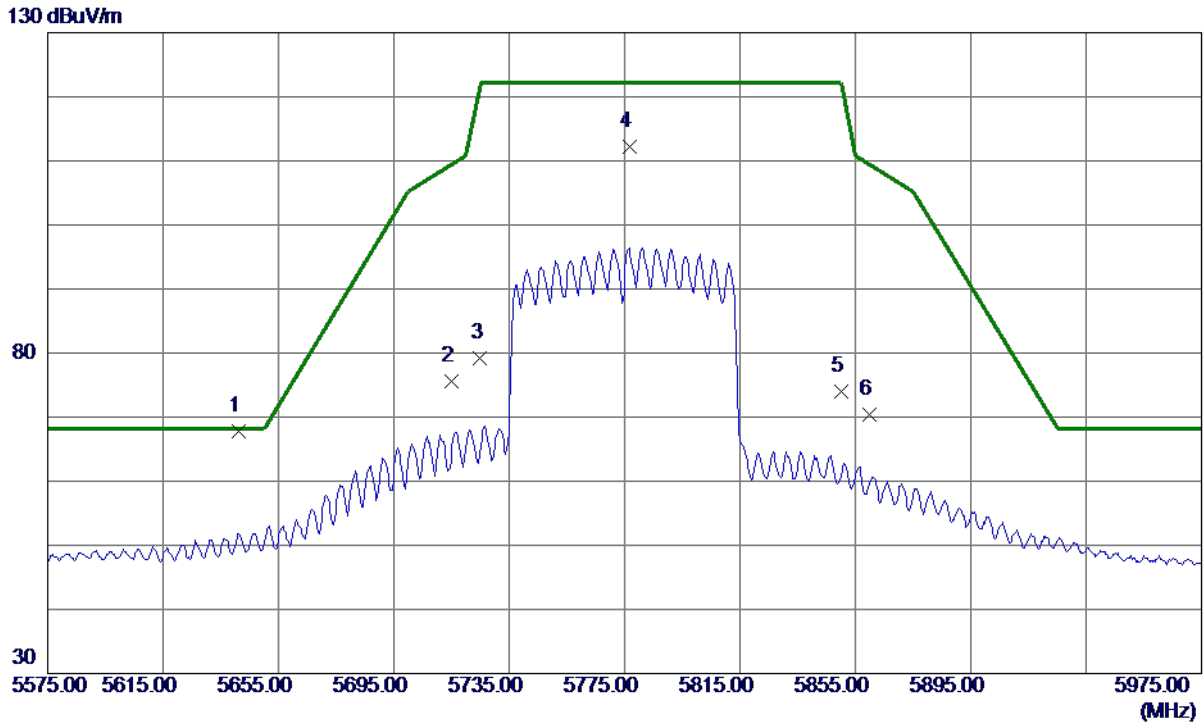

No.	Freq. MHz	Reading Level dBuV/m	Correct Factor dB	Measure ment dBuV/m	Limit dBuV/m	Margin dB	Detector	Comment
1 *	5641.4000	51.92	15.95	67.87	68.20	-0.33	Peak	
2	5715.0000	59.57	15.99	75.56	109.40	-33.84	Peak	
3	5725.0000	63.14	16.00	79.14	122.20	-43.06	Peak	
4	5776.8000	96.26	16.03	112.29	122.20	-9.91	Peak	No Limit
5	5850.0000	57.90	16.08	73.98	122.20	-48.22	Peak	
6	5860.0000	54.33	16.08	70.41	109.40	-38.99	Peak	

**REMARKS:**

- (1) Measurement Value = Reading Level + Correct Factor.
- (2) Margin Level = Measurement Value - Limit Value.

Orthogonal Axis	X
Test Mode	UNII-3_TX AC (VHT80) Mode 5775 MHz

### Vertical

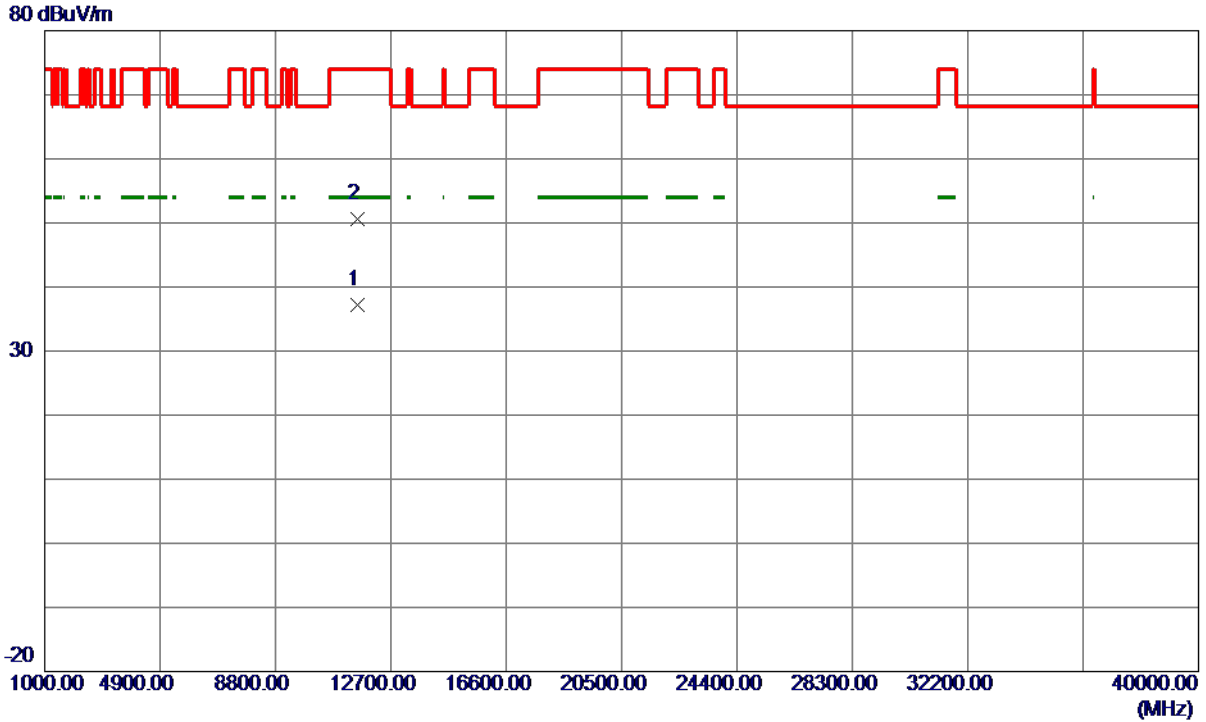

No.	Freq. MHz	Reading Level dBuV/m	Correct Factor dB	Measure ment dBuV/m	Limit dBuV/m	Margin dB	Detector	Comment
1 *	11555.9250	26.41	10.84	37.25	54.00	-16.75	AVG	
2	11569.1000	39.82	10.86	50.68	74.00	-23.32	Peak	

**REMARKS:**

- (1) Measurement Value = Reading Level + Correct Factor.
- (2) Margin Level = Measurement Value - Limit Value.



Orthogonal Axis	X
Test Mode	UNII-3_TX AC (VHT80) Mode 5775 MHz

### Horizontal

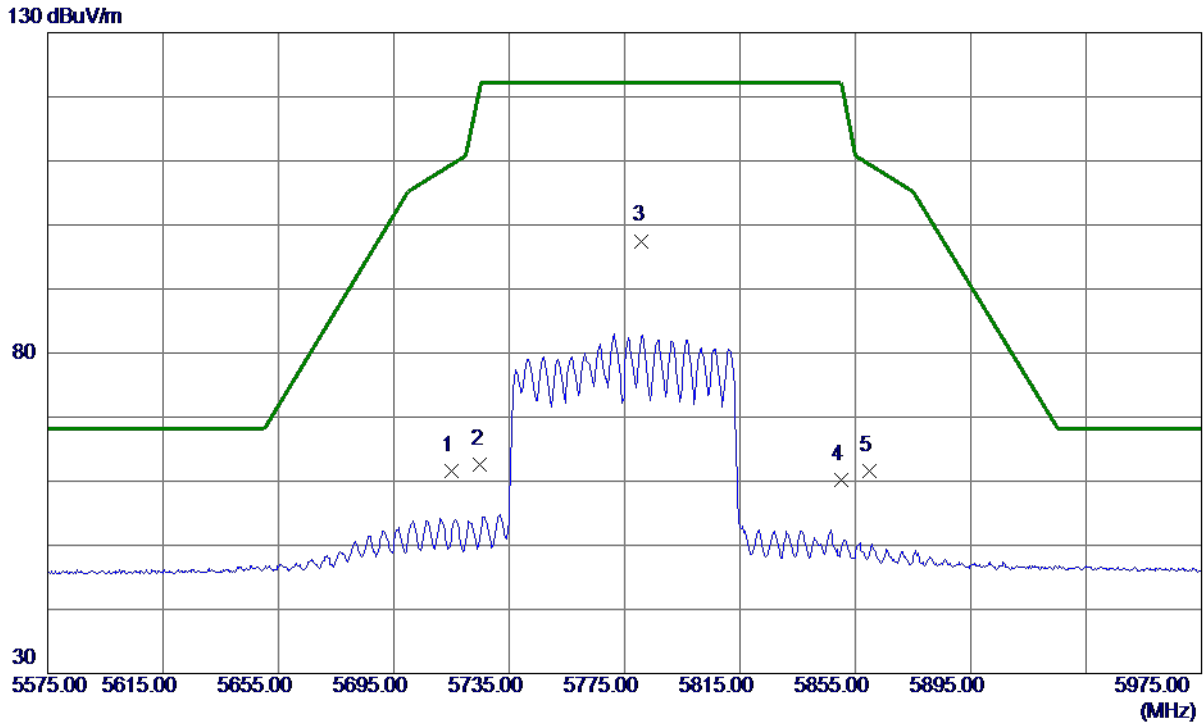

No.	Freq. MHz	Reading Level dBuV/m	Correct Factor dB	Measure ment dBuV/m	Limit dBuV/m	Margin dB	Detector	Comment
1	5715.0000	45.65	15.99	61.64	109.40	-47.76	Peak	
2	5725.0000	46.62	16.00	62.62	122.20	-59.58	Peak	
3 *	5781.0000	81.47	16.03	97.50	122.20	-24.70	Peak	No Limit
4	5850.0000	44.07	16.08	60.15	122.20	-62.05	Peak	
5	5860.0000	45.52	16.08	61.60	109.40	-47.80	Peak	

**REMARKS:**

- (1) Measurement Value = Reading Level + Correct Factor.
- (2) Margin Level = Measurement Value - Limit Value.

Orthogonal Axis	X
Test Mode	UNII-3_TX AC (VHT80) Mode 5775 MHz

### Horizontal

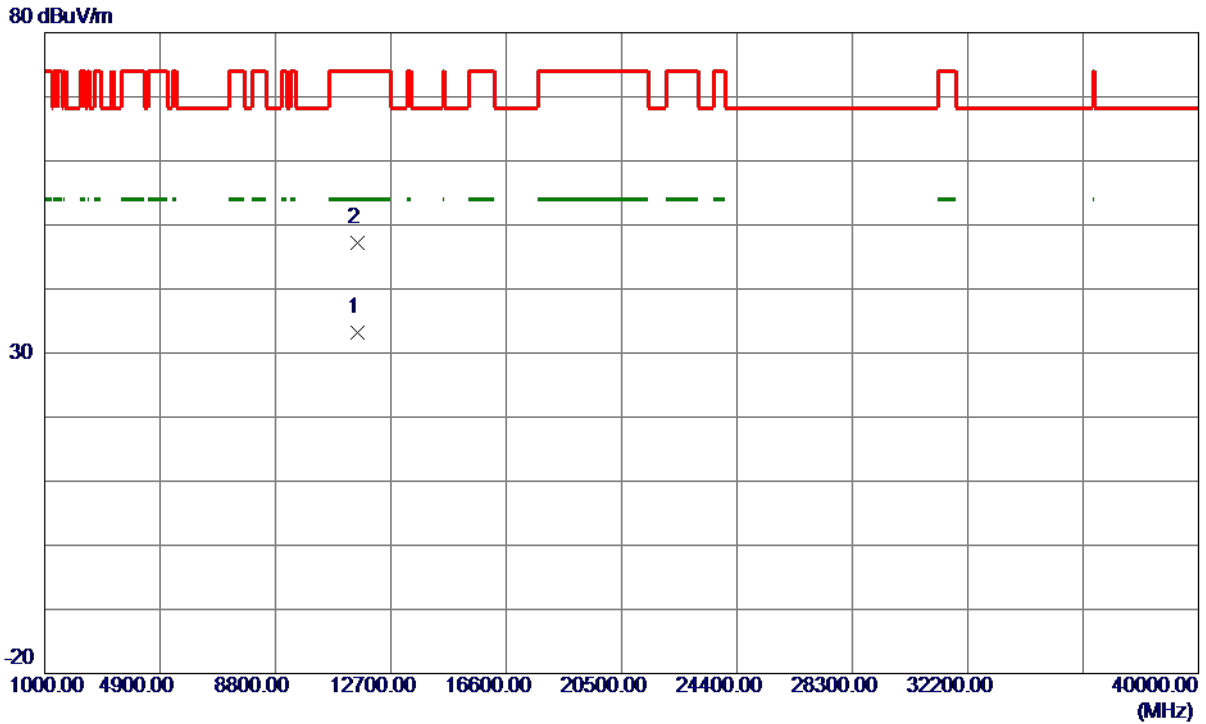

No.	Freq. MHz	Reading Level dBuV/m	Correct Factor dB	Measure ment dBuV/m	Limit dBuV/m	Margin dB	Detector	Comment
1 *	11568.7500	22.42	10.86	33.28	54.00	-20.72	AVG	
2	11569.2750	36.31	10.86	47.17	74.00	-26.83	Peak	

**REMARKS:**

- (1) Measurement Value = Reading Level + Correct Factor.
- (2) Margin Level = Measurement Value - Limit Value.

## With Beamforming

Orthogonal Axis	X
Test Mode	UNII-1_TX AC (VHT20) Mode 5180 MHz

### Vertical

130 dBuV/m

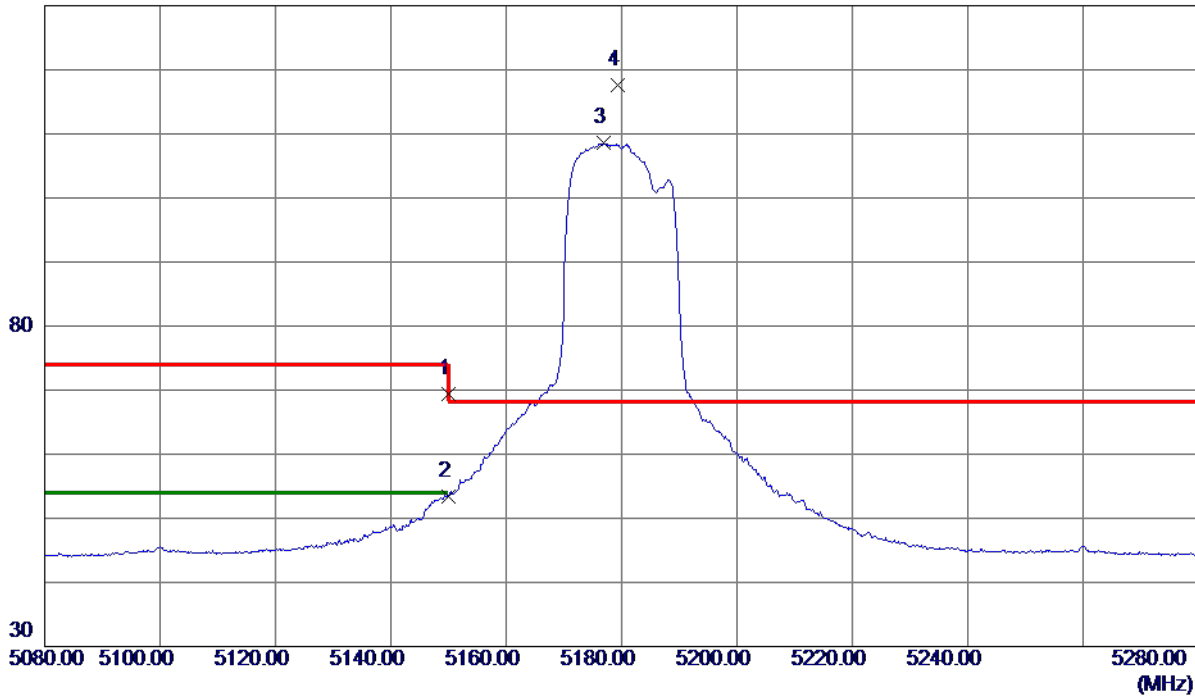

No.	Freq. MHz	Reading Level dBuV/m	Correct Factor dB	Measure ment dBuV/m	Limit dBuV/m	Margin dB	Detector	Comment
1	5150.0000	54.41	15.02	69.43	74.00	-4.57	Peak	
2	5150.0000	38.42	15.02	53.44	54.00	-0.56	AVG	
3	5176.9000	93.55	15.03	108.58	999.00	-890.42	AVG	No Limit
4 *	5179.3000	102.57	15.04	117.61	68.30	49.31	Peak	No Limit

**REMARKS:**

- (1) Measurement Value = Reading Level + Correct Factor.
- (2) Margin Level = Measurement Value - Limit Value.

Orthogonal Axis	X
Test Mode	UNII-1_TX AC (VHT20) Mode 5180 MHz

### Vertical

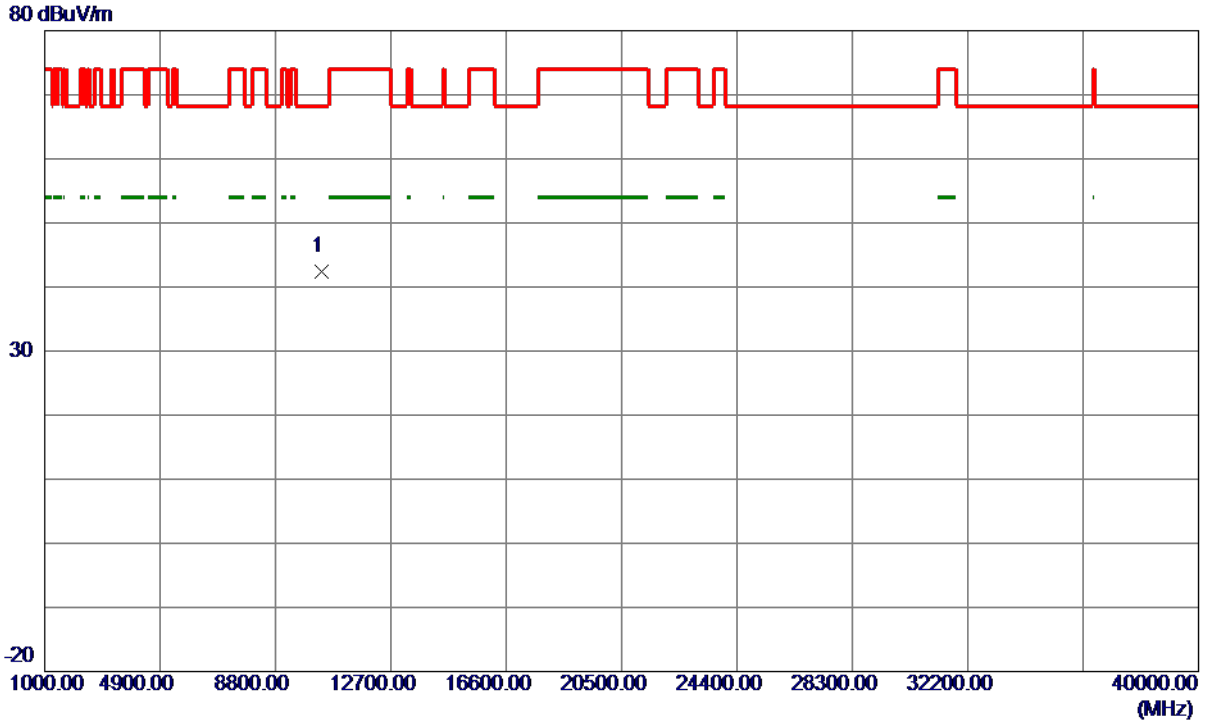

No.	Freq. MHz	Reading Level dBuV/m	Correct Factor dB	Measure ment dBuV/m	Limit dBuV/m	Margin dB	Detector	Comment
1 *	10350.2500	33.49	8.88	42.37	68.30	-25.93	Peak	

**REMARKS:**

- (1) Measurement Value = Reading Level + Correct Factor.
- (2) Margin Level = Measurement Value - Limit Value.

Orthogonal Axis	X
Test Mode	UNII-1_TX AC (VHT20) Mode 5180 MHz

### Horizontal

130 dBuV/m

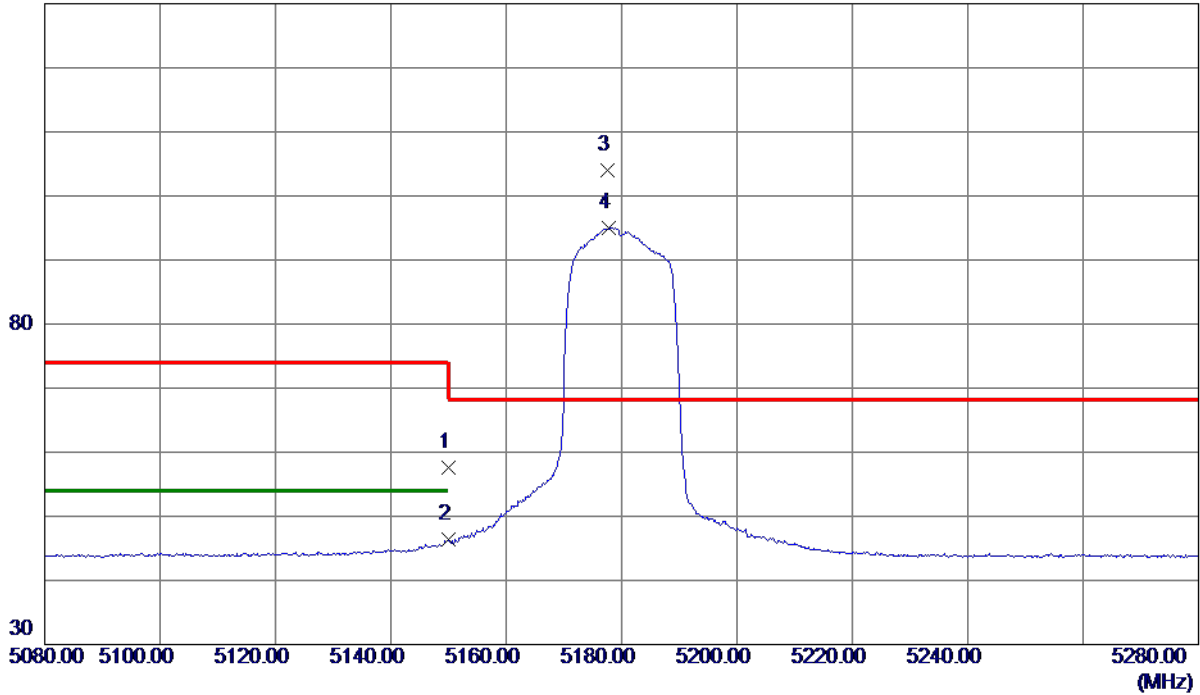

No.	Freq. MHz	Reading Level dBuV/m	Correct Factor dB	Measure ment dBuV/m	Limit dBuV/m	Margin dB	Detector	Comment
1	5150.0000	42.60	15.02	57.62	74.00	-16.38	Peak	
2	5150.0000	31.29	15.02	46.31	54.00	-7.69	AVG	
3 *	5177.5000	88.98	15.03	104.01	68.30	35.71	Peak	No Limit
4	5177.7000	80.03	15.03	95.06	999.00	-903.94	AVG	No Limit

**REMARKS:**

- (1) Measurement Value = Reading Level + Correct Factor.
- (2) Margin Level = Measurement Value - Limit Value.

Orthogonal Axis	X
Test Mode	UNII-1_TX AC (VHT20) Mode 5180 MHz

### Horizontal

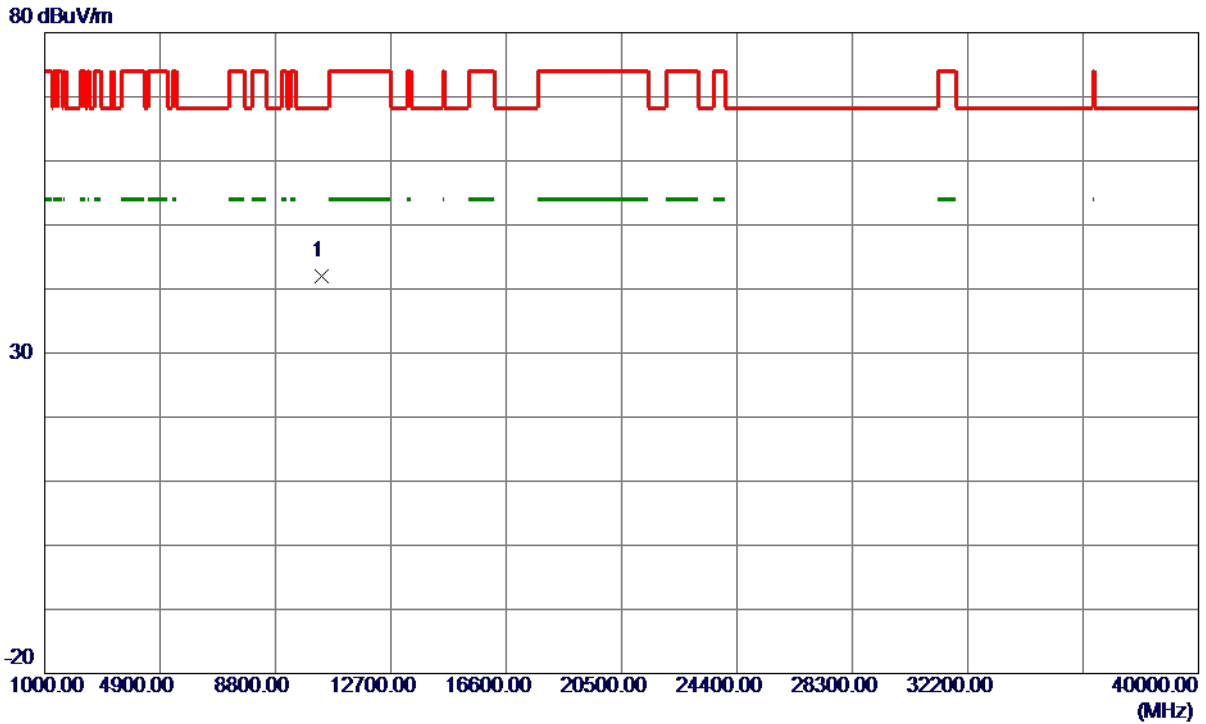

No.	Freq. MHz	Reading Level dBuV/m	Correct Factor dB	Measure ment dBuV/m	Limit dBuV/m	Margin dB	Detector	Comment
1 *	10373.8750	33.07	8.92	41.99	68.30	-26.31	Peak	

**REMARKS:**

- (1) Measurement Value = Reading Level + Correct Factor.
- (2) Margin Level = Measurement Value - Limit Value.

Orthogonal Axis	X
Test Mode	UNII-1_TX AC (VHT20) Mode 5200 MHz

### Vertical

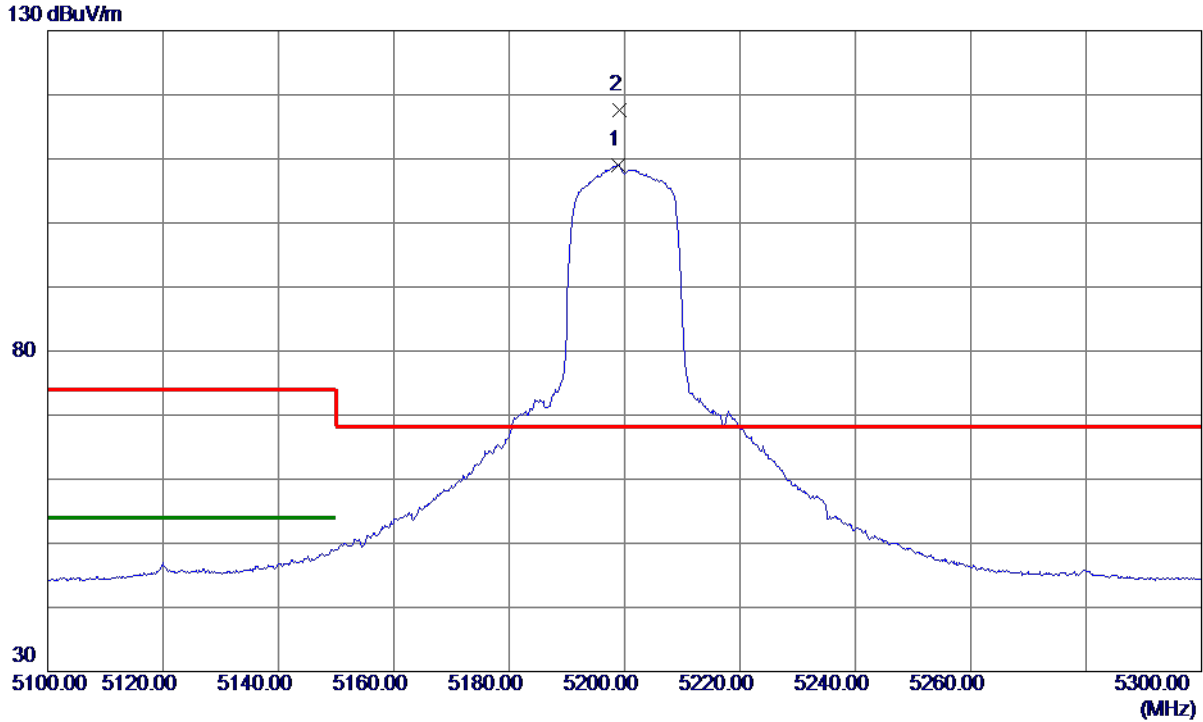

No.	Freq. MHz	Reading Level dBuV/m	Correct Factor dB	Measure ment dBuV/m	Limit dBuV/m	Margin dB	Detector	Comment
1	5198.9000	93.99	15.05	109.04	999.00	-889.96	AVG	No Limit
2 *	5199.1000	102.49	15.05	117.54	68.30	49.24	Peak	No Limit

**REMARKS:**

- (1) Measurement Value = Reading Level + Correct Factor.
- (2) Margin Level = Measurement Value - Limit Value.

Orthogonal Axis	X
Test Mode	UNII-1_TX AC (VHT20) Mode 5200 MHz

### Vertical

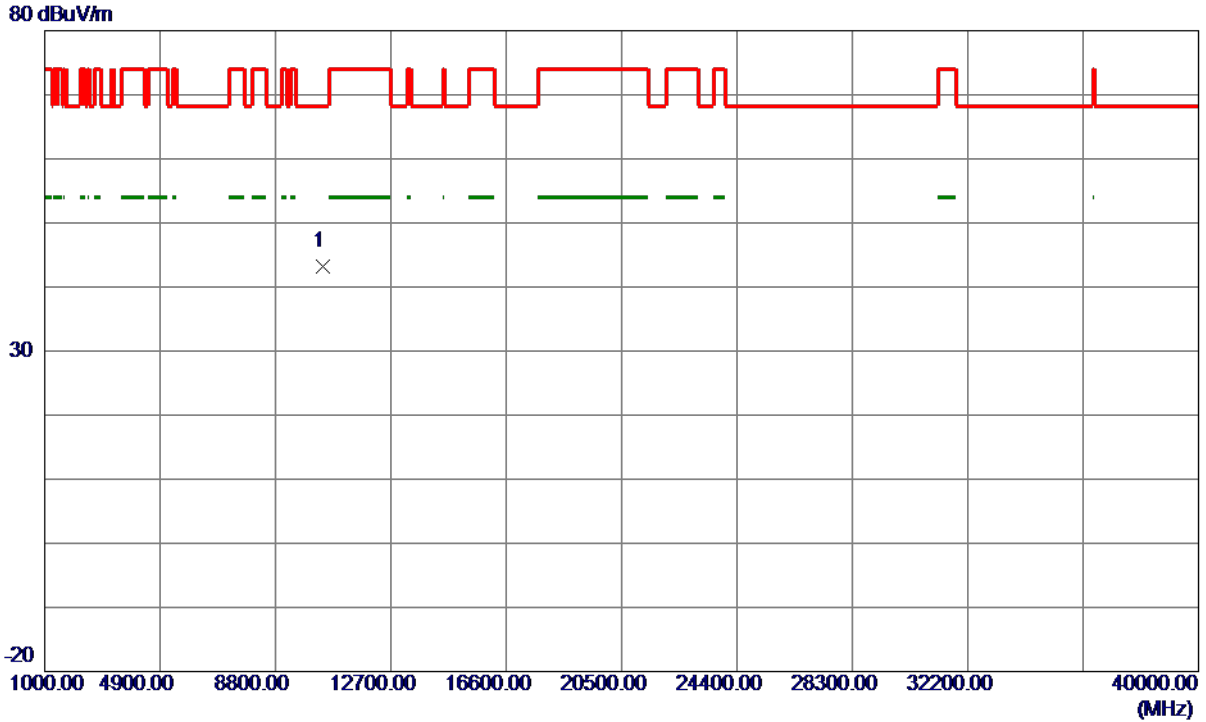

No.	Freq. MHz	Reading Level dBuV/m	Correct Factor dB	Measure ment dBuV/m	Limit dBuV/m	Margin dB	Detector	Comment
1 *	10408.4000	34.30	8.99	43.29	68.30	-25.01	Peak	

**REMARKS:**

- (1) Measurement Value = Reading Level + Correct Factor.
- (2) Margin Level = Measurement Value - Limit Value.



Orthogonal Axis	X
Test Mode	UNII-1_TX AC (VHT20) Mode 5200 MHz

### Horizontal

130 dBuV/m

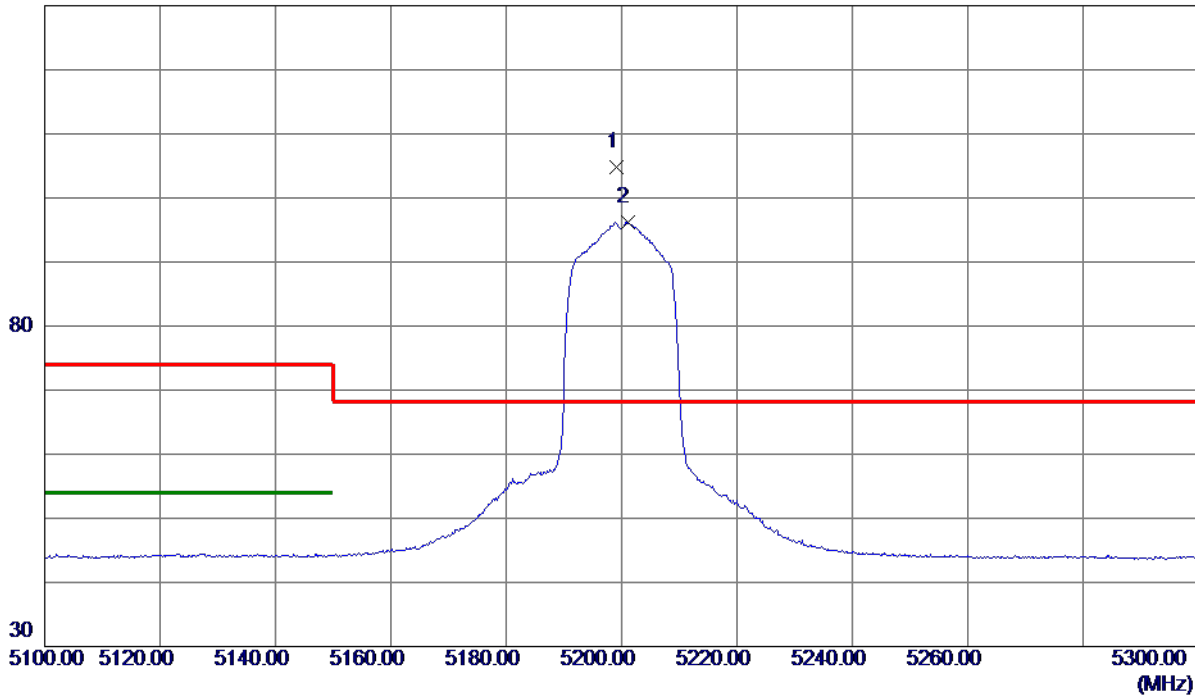

No.	Freq. MHz	Reading Level dBuV/m	Correct Factor dB	Measure ment dBuV/m	Limit dBuV/m	Margin dB	Detector	Comment
1 *	5199.1000	89.73	15.05	104.78	68.30	36.48	Peak	No Limit
2	5201.0000	81.24	15.05	96.29	999.00	-902.71	AVG	No Limit

**REMARKS:**

- (1) Measurement Value = Reading Level + Correct Factor.
- (2) Margin Level = Measurement Value - Limit Value.

Orthogonal Axis	X
Test Mode	UNII-1_TX AC (VHT20) Mode 5200 MHz

### Horizontal

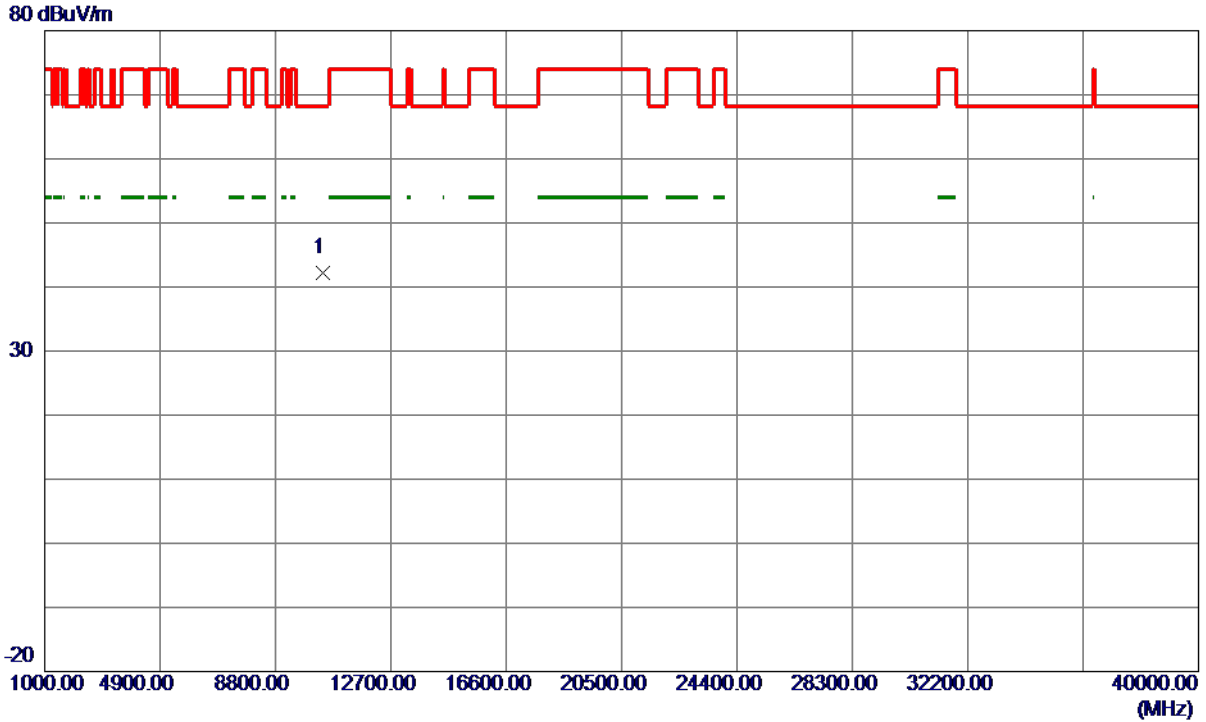

No.	Freq. MHz	Reading Level dBuV/m	Correct Factor dB	Measure ment dBuV/m	Limit dBuV/m	Margin dB	Detector	Comment
1 *	10404.3250	33.28	8.98	42.26	68.30	-26.04	Peak	

**REMARKS:**

- (1) Measurement Value = Reading Level + Correct Factor.
- (2) Margin Level = Measurement Value - Limit Value.

Orthogonal Axis	X
Test Mode	UNII-1_TX AC (VHT20) Mode 5240 MHz

### Vertical

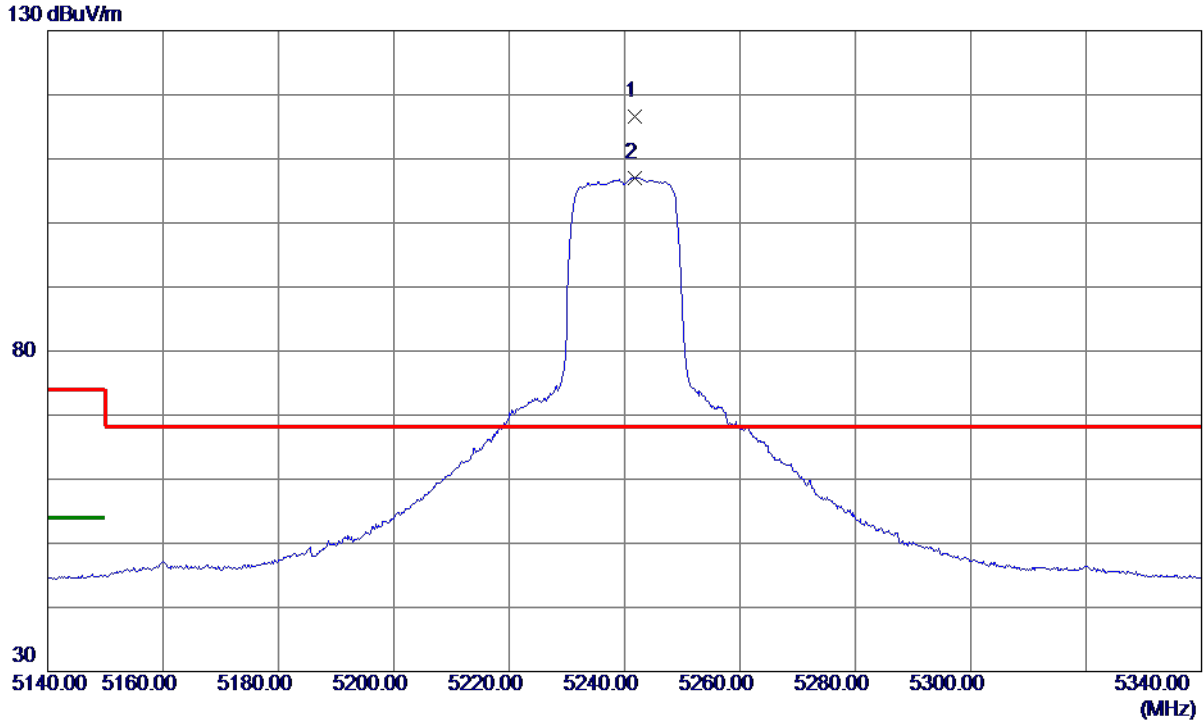

No.	Freq. MHz	Reading Level dBuV/m	Correct Factor dB	Measure ment dBuV/m	Limit dBuV/m	Margin dB	Detector	Comment
1 *	5241.7000	101.55	15.08	116.63	68.30	48.33	Peak	No Limit
2	5241.8000	91.97	15.08	107.05	999.00	-891.95	AVG	No Limit

**REMARKS:**

- (1) Measurement Value = Reading Level + Correct Factor.
- (2) Margin Level = Measurement Value - Limit Value.

Orthogonal Axis	X
Test Mode	UNII-1_TX AC (VHT20) Mode 5240 MHz

### Vertical

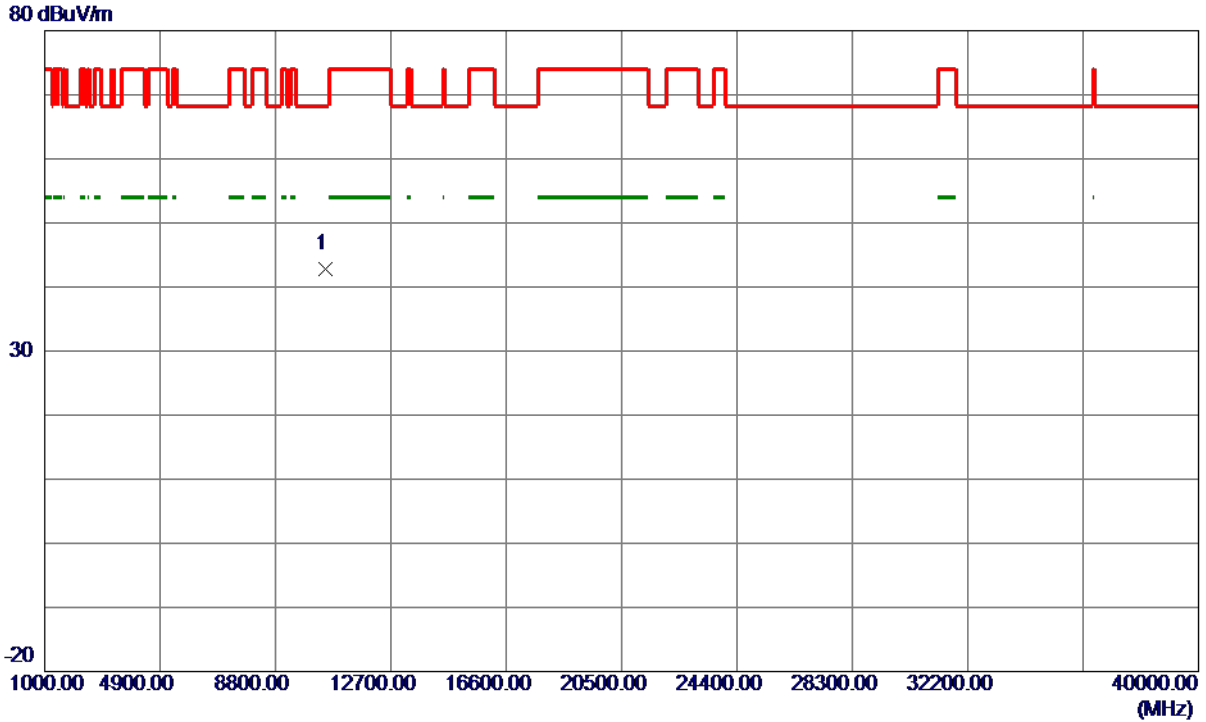

No.	Freq. MHz	Reading Level dBuV/m	Correct Factor dB	Measure ment dBuV/m	Limit dBuV/m	Margin dB	Detector	Comment
1 *	10481.7500	33.69	9.13	42.82	68.30	-25.48	Peak	

**REMARKS:**

- (1) Measurement Value = Reading Level + Correct Factor.
- (2) Margin Level = Measurement Value - Limit Value.

Orthogonal Axis	X
Test Mode	UNII-1_TX AC (VHT20) Mode 5240 MHz

### Horizontal

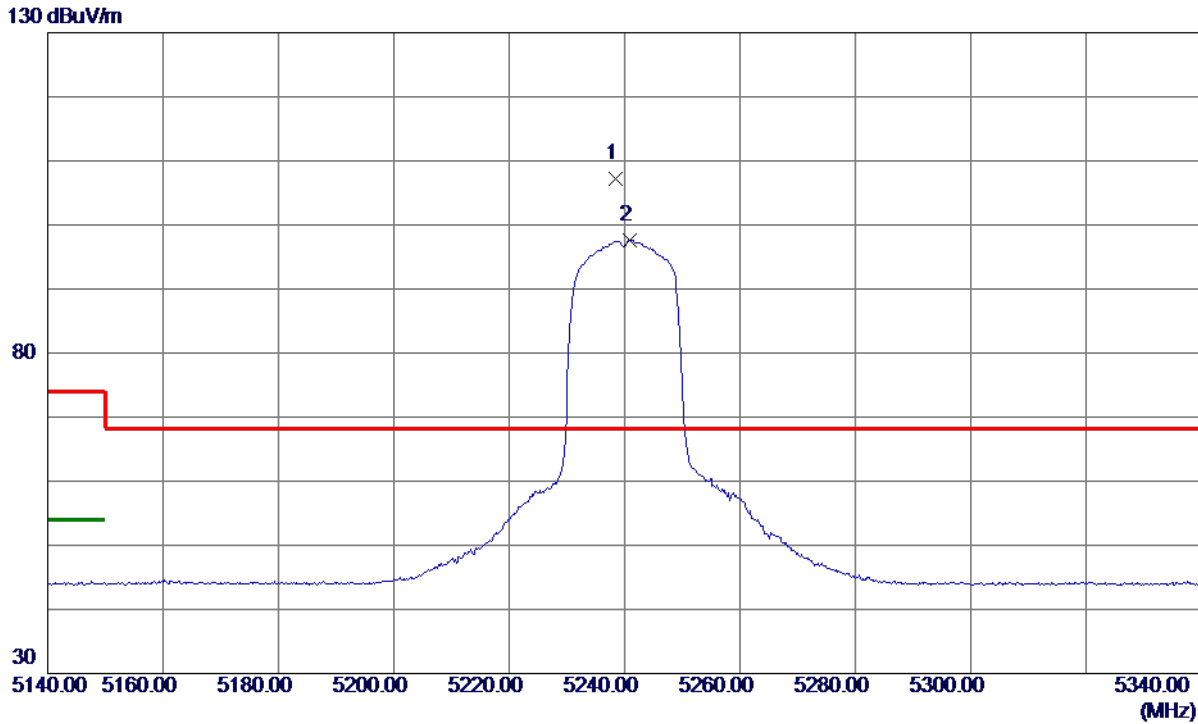

No.	Freq. MHz	Reading Level dBuV/m	Correct Factor dB	Measure ment dBuV/m	Limit dBuV/m	Margin dB	Detector	Comment
1 *	5238.4000	92.04	15.08	107.12	68.30	38.82	Peak	No Limit
2	5240.9000	82.54	15.08	97.62	999.00	-901.38	AVG	No Limit

**REMARKS:**

- (1) Measurement Value = Reading Level + Correct Factor.
- (2) Margin Level = Measurement Value - Limit Value.

Orthogonal Axis	X
Test Mode	UNII-1_TX AC (VHT20) Mode 5240 MHz

### Horizontal

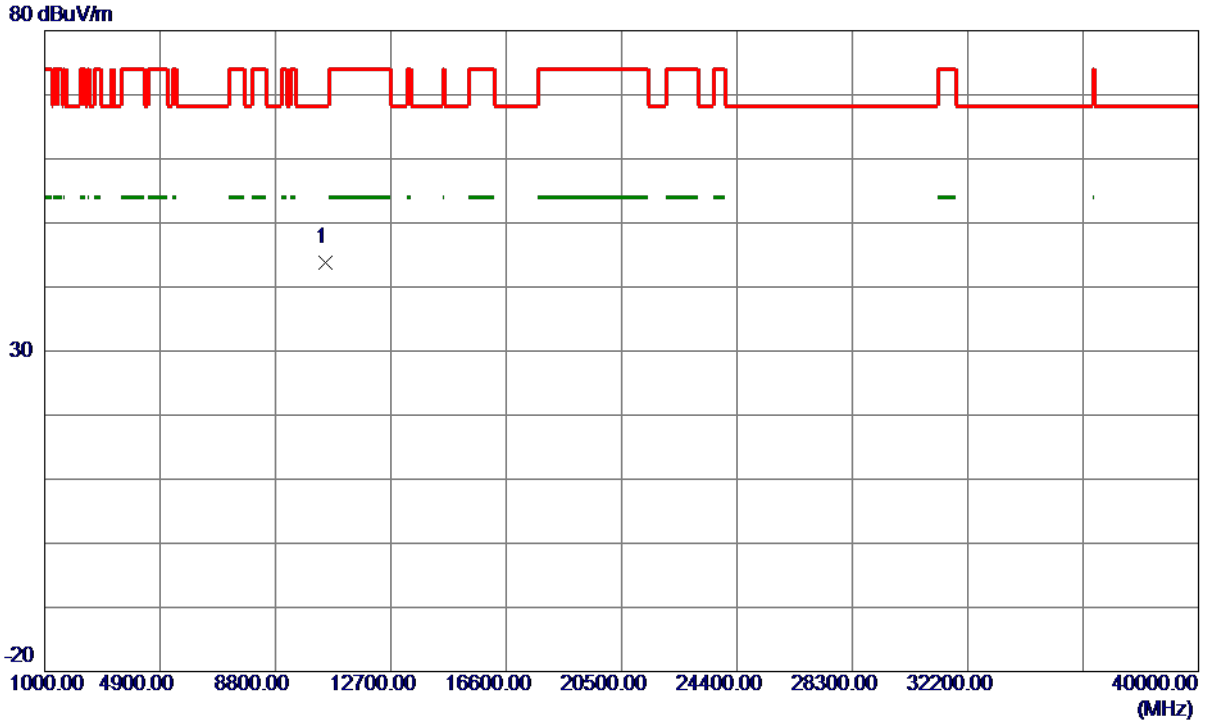

No.	Freq. MHz	Reading Level dBuV/m	Correct Factor dB	Measure ment dBuV/m	Limit dBuV/m	Margin dB	Detector	Comment
1 *	10471.0750	34.62	9.11	43.73	68.30	-24.57	Peak	

**REMARKS:**

- (1) Measurement Value = Reading Level + Correct Factor.
- (2) Margin Level = Measurement Value - Limit Value.

Orthogonal Axis	X
Test Mode	UNII-1_TX AC (VHT40) Mode 5190 MHz

### Vertical

130 dBuV/m

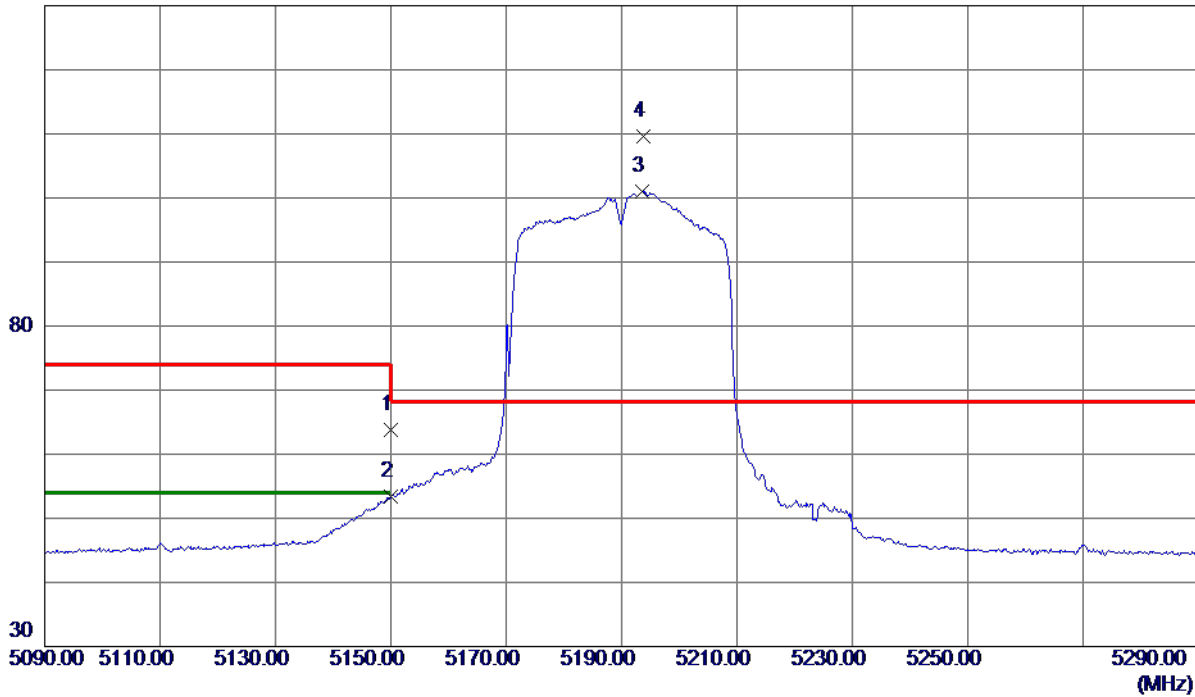

No.	Freq. MHz	Reading Level dBuV/m	Correct Factor dB	Measure ment dBuV/m	Limit dBuV/m	Margin dB	Detector	Comment
1	5150.0000	48.80	15.02	63.82	74.00	-10.18	Peak	
2	5150.0000	38.33	15.02	53.35	54.00	-0.65	AVG	
3	5193.6000	86.04	15.05	101.09	999.00	-897.91	AVG	No Limit
4 *	5193.8000	94.61	15.05	109.66	68.30	41.36	Peak	No Limit

**REMARKS:**

- (1) Measurement Value = Reading Level + Correct Factor.
- (2) Margin Level = Measurement Value - Limit Value.

Orthogonal Axis	X
Test Mode	UNII-1_TX AC (VHT40) Mode 5190 MHz

### Vertical

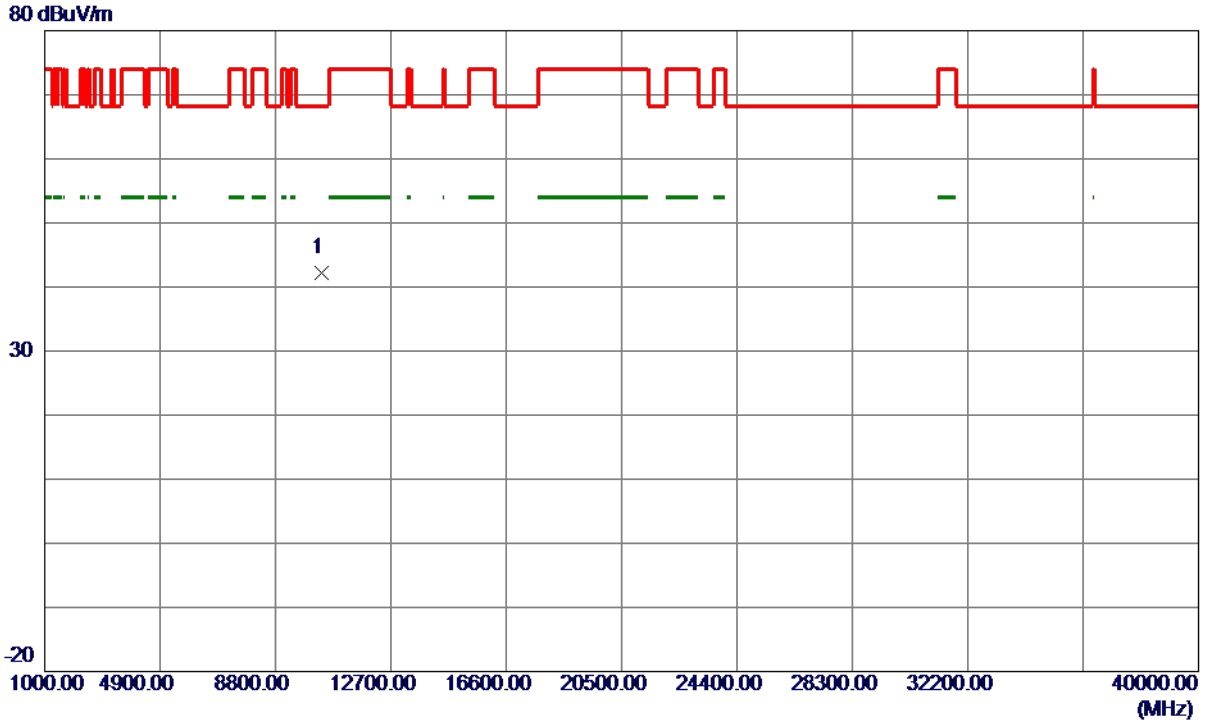

No.	Freq. MHz	Reading Level dBuV/m	Correct Factor dB	Measure ment dBuV/m	Limit dBuV/m	Margin dB	Detector	Comment
1 *	10373.7750	33.22	8.92	42.14	68.30	-26.16	Peak	

**REMARKS:**

- (1) Measurement Value = Reading Level + Correct Factor.
- (2) Margin Level = Measurement Value - Limit Value.



Orthogonal Axis	X
Test Mode	UNII-1_TX AC (VHT40) Mode 5190 MHz

### Horizontal

130 dBuV/m

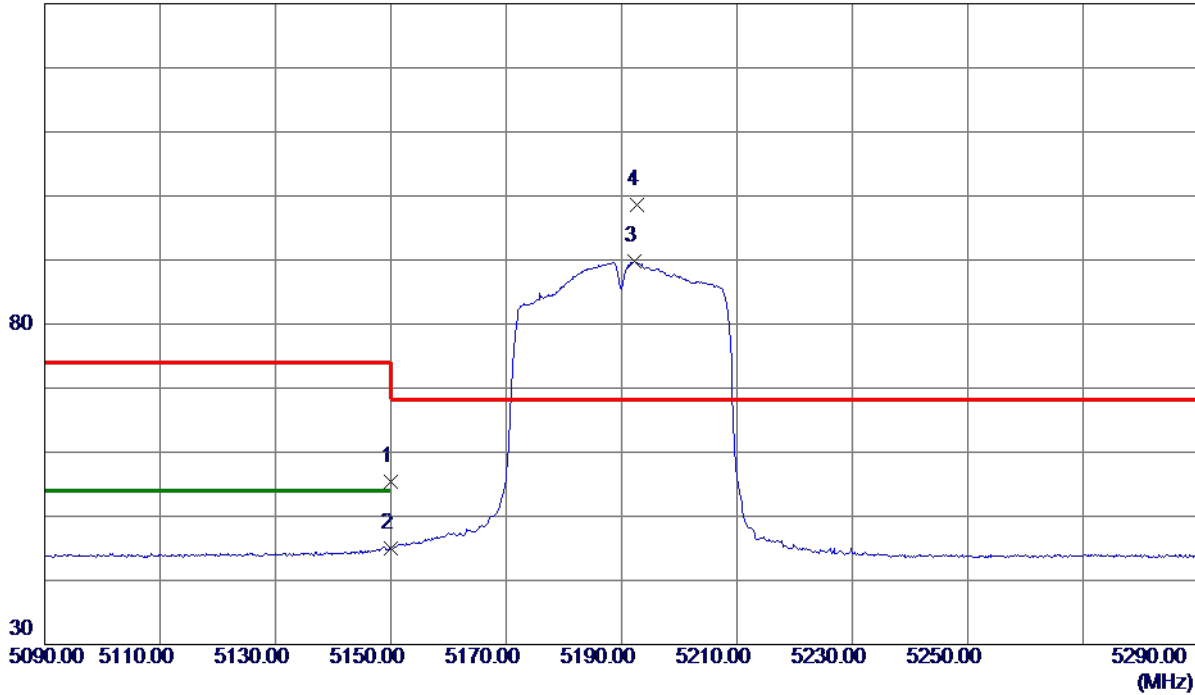

No.	Freq. MHz	Reading Level dBuV/m	Correct Factor dB	Measure ment dBuV/m	Limit dBuV/m	Margin dB	Detector	Comment
1	5150.0000	40.31	15.02	55.33	74.00	-18.67	Peak	
2	5150.0000	29.99	15.02	45.01	54.00	-8.99	AVG	
3	5192.2000	74.74	15.04	89.78	999.00	-909.22	AVG	No Limit
4 *	5192.7000	83.54	15.04	98.58	68.30	30.28	Peak	No Limit

**REMARKS:**

- (1) Measurement Value = Reading Level + Correct Factor.
- (2) Margin Level = Measurement Value - Limit Value.

Orthogonal Axis	X
Test Mode	UNII-1_TX AC (VHT40) Mode 5190 MHz

### Horizontal

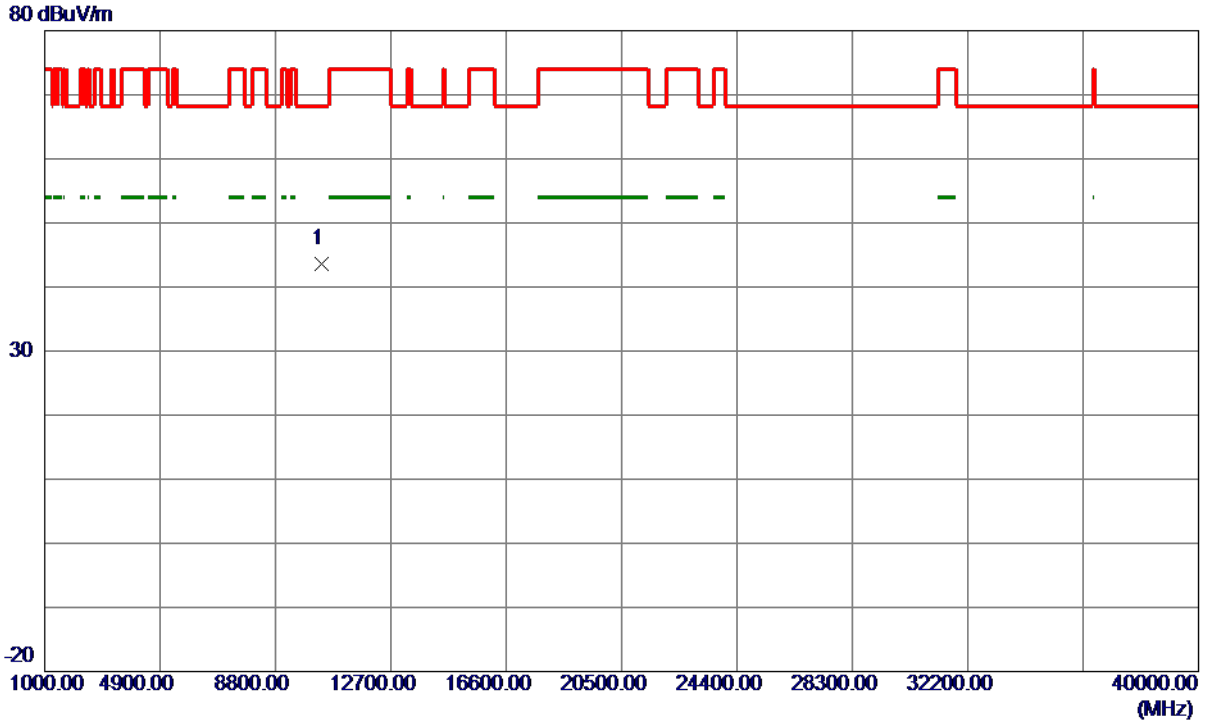

No.	Freq. MHz	Reading Level dBuV/m	Correct Factor dB	Measure ment dBuV/m	Limit dBuV/m	Margin dB	Detector	Comment
1 *	10365.1500	34.68	8.91	43.59	68.30	-24.71	Peak	

**REMARKS:**

- (1) Measurement Value = Reading Level + Correct Factor.
- (2) Margin Level = Measurement Value - Limit Value.

Orthogonal Axis	X
Test Mode	UNII-1_TX AC (VHT40) Mode 5230 MHz

### Vertical

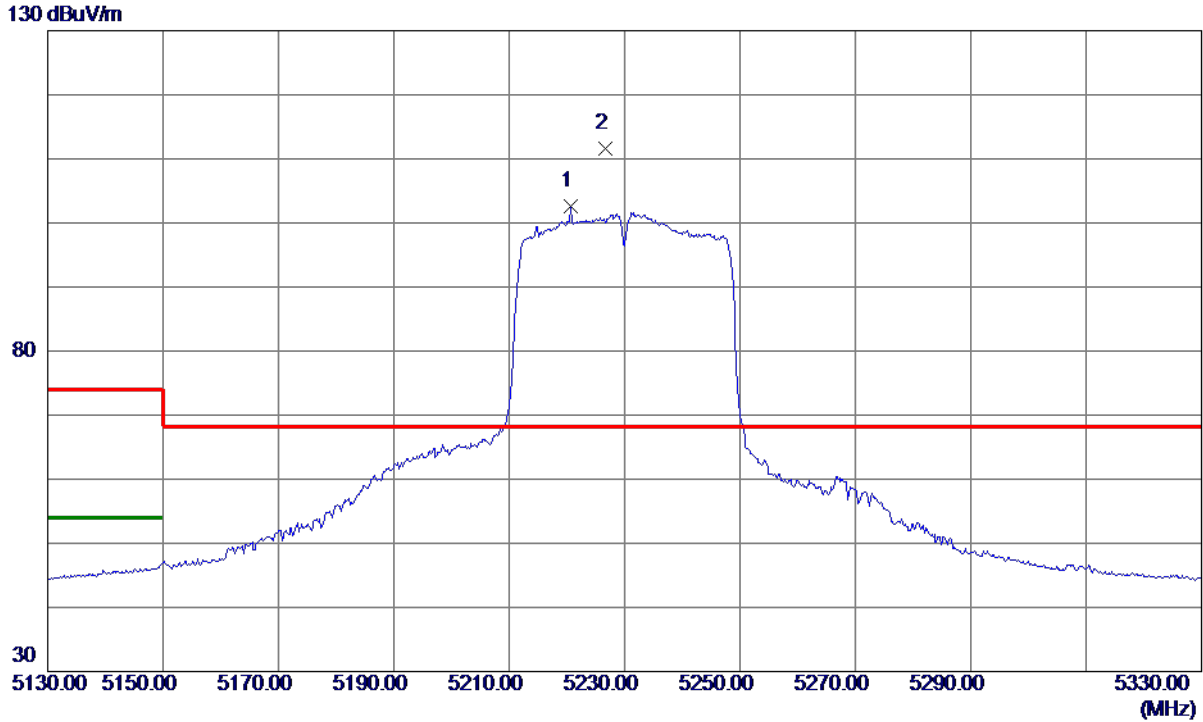

No.	Freq. MHz	Reading Level dBuV/m	Correct Factor dB	Measure ment dBuV/m	Limit dBuV/m	Margin dB	Detector	Comment
1	5220.7000	87.60	15.06	102.66	999.00	-896.34	AVG	No Limit
2 *	5226.6000	96.54	15.07	111.61	68.30	43.31	Peak	No Limit

**REMARKS:**

- (1) Measurement Value = Reading Level + Correct Factor.
- (2) Margin Level = Measurement Value - Limit Value.

Orthogonal Axis	X
Test Mode	UNII-1_TX AC (VHT40) Mode 5230 MHz

### Vertical

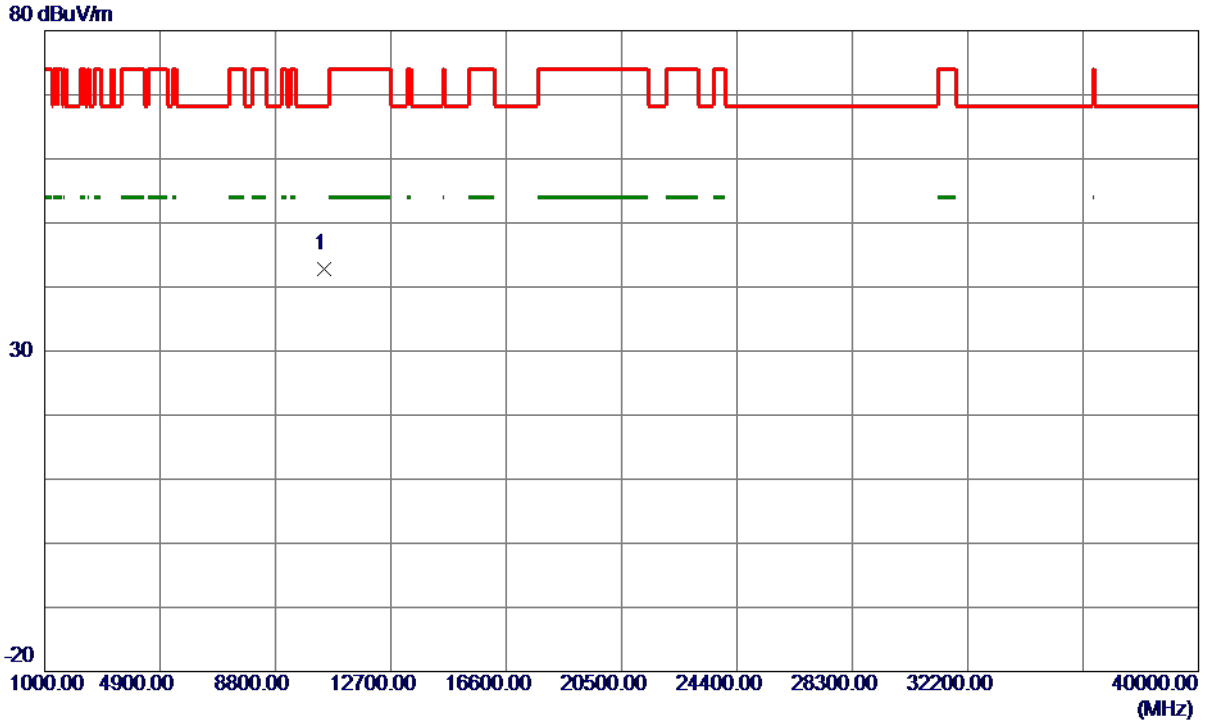

No.	Freq. MHz	Reading Level dBuV/m	Correct Factor dB	Measure ment dBuV/m	Limit dBuV/m	Margin dB	Detector	Comment
1 *	10447.2250	33.74	9.06	42.80	68.30	-25.50	Peak	

**REMARKS:**

- (1) Measurement Value = Reading Level + Correct Factor.
- (2) Margin Level = Measurement Value - Limit Value.

Orthogonal Axis	X
Test Mode	UNII-1_TX AC (VHT40) Mode 5230 MHz

### Horizontal

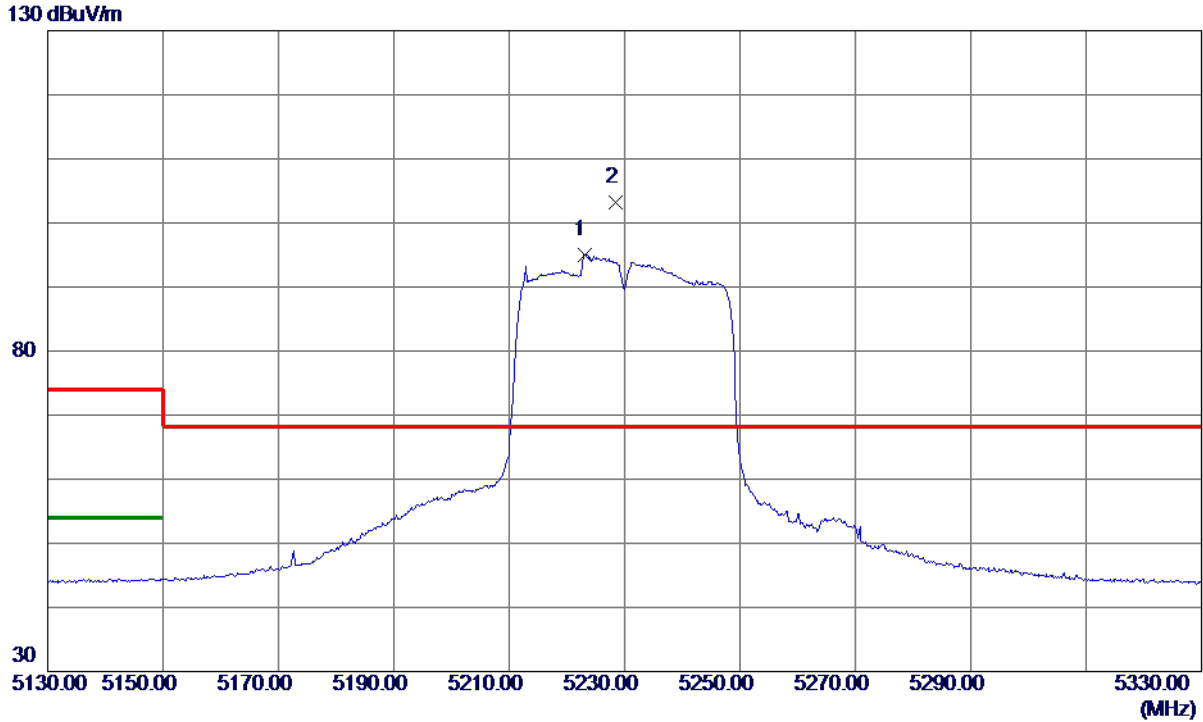

No.	Freq. MHz	Reading Level dBuV/m	Correct Factor dB	Measure ment dBuV/m	Limit dBuV/m	Margin dB	Detector	Comment
1	5223.0000	79.93	15.07	95.00	999.00	-904.00	AVG	No Limit
2 *	5228.5000	88.07	15.07	103.14	68.30	34.84	Peak	No Limit

**REMARKS:**

- (1) Measurement Value = Reading Level + Correct Factor.
- (2) Margin Level = Measurement Value - Limit Value.

Orthogonal Axis	X
Test Mode	UNII-1_TX AC (VHT40) Mode 5230 MHz

### Horizontal

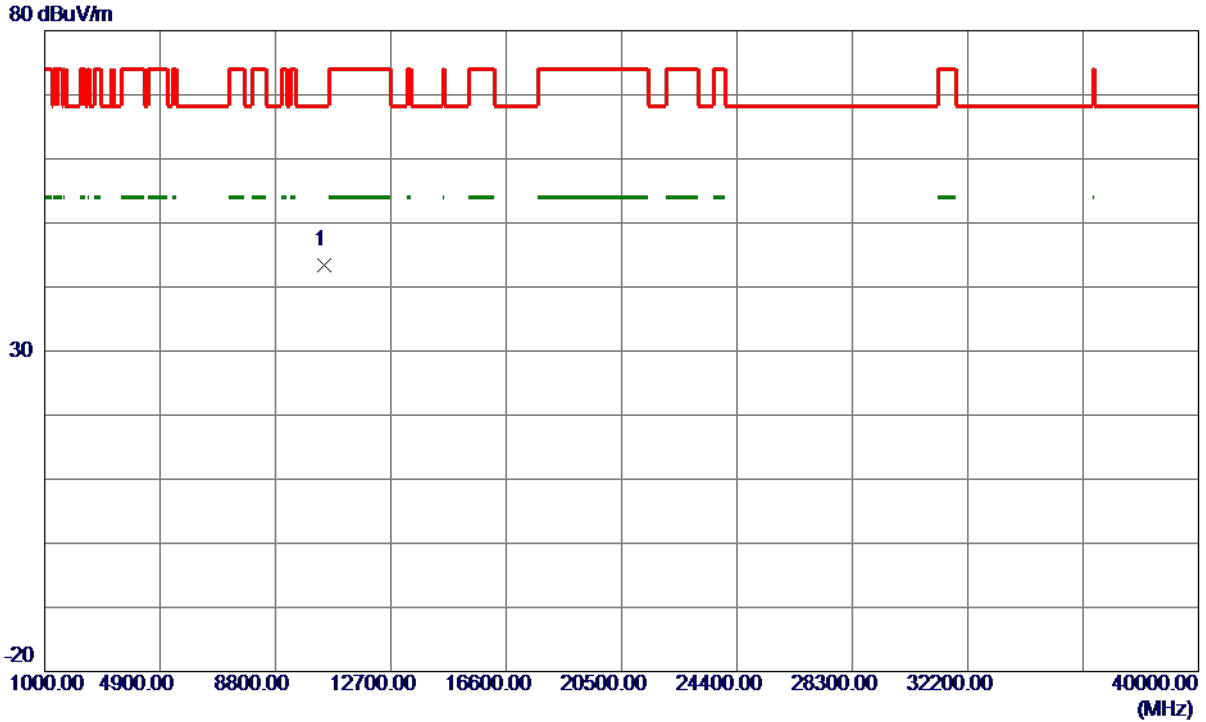

No.	Freq. MHz	Reading Level dBuV/m	Correct Factor dB	Measure ment dBuV/m	Limit dBuV/m	Margin dB	Detector	Comment
1 *	10445.5750	34.27	9.06	43.33	68.30	-24.97	Peak	

**REMARKS:**

- (1) Measurement Value = Reading Level + Correct Factor.
- (2) Margin Level = Measurement Value - Limit Value.

Orthogonal Axis	X
Test Mode	UNII-1_TX AC (VHT80) Mode 5210 MHz

### Vertical

130 dBuV/m



No.	Freq. MHz	Reading Level dBuV/m	Correct Factor dB	Measure ment dBuV/m	Limit dBuV/m	Margin dB	Detector	Comment
1	5136.0000	46.66	15.01	61.67	74.00	-12.33	Peak	
2	5136.0000	38.77	15.01	53.78	54.00	-0.22	AVG	
3	5150.0000	46.92	15.02	61.94	74.00	-12.06	Peak	
4	5150.0000	38.34	15.02	53.36	54.00	-0.64	AVG	
5	5175.6000	78.89	15.03	93.92	999.00	-905.08	AVG	No Limit
6 *	5226.0000	83.82	15.07	98.89	68.30	30.59	Peak	No Limit

**REMARKS:**

- (1) Measurement Value = Reading Level + Correct Factor.
- (2) Margin Level = Measurement Value - Limit Value.

Orthogonal Axis	X
Test Mode	UNII-1_TX AC (VHT80) Mode 5210 MHz

### Vertical

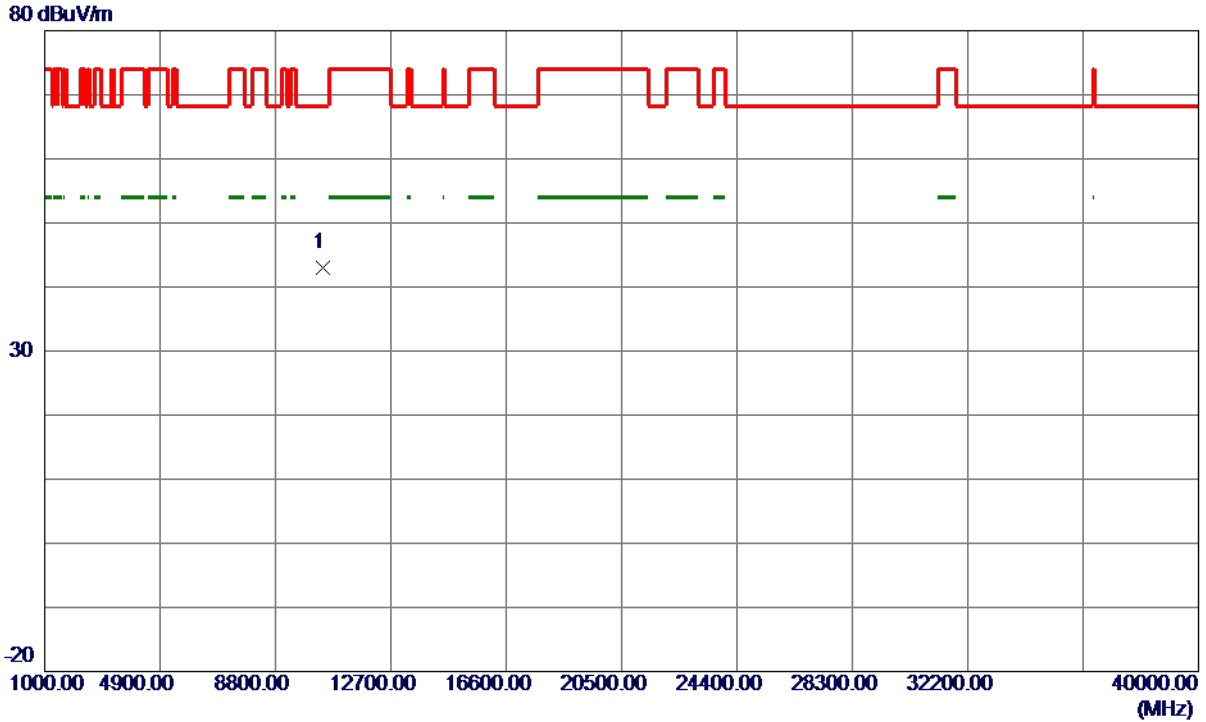

No.	Freq. MHz	Reading Level dBuV/m	Correct Factor dB	Measure ment dBuV/m	Limit dBuV/m	Margin dB	Detector	Comment
1 *	10400.2000	34.06	8.97	43.03	68.30	-25.27	Peak	

**REMARKS:**

- (1) Measurement Value = Reading Level + Correct Factor.
- (2) Margin Level = Measurement Value - Limit Value.



Orthogonal Axis	X
Test Mode	UNII-1_TX AC (VHT80) Mode 5210 MHz

### Horizontal

130 dBuV/m



No.	Freq. MHz	Reading Level dBuV/m	Correct Factor dB	Measure ment dBuV/m	Limit dBuV/m	Margin dB	Detector	Comment
1	5150.0000	40.36	15.02	55.38	74.00	-18.62	Peak	
2	5150.0000	30.67	15.02	45.69	54.00	-8.31	AVG	
3 *	5207.2000	78.19	15.06	93.25	68.30	24.95	Peak	No Limit
4	5211.6000	66.33	15.06	81.39	999.00	-917.61	AVG	No Limit

**REMARKS:**

- (1) Measurement Value = Reading Level + Correct Factor.
- (2) Margin Level = Measurement Value - Limit Value.

Orthogonal Axis	X
Test Mode	UNII-1_TX AC (VHT80) Mode 5210 MHz

### Horizontal

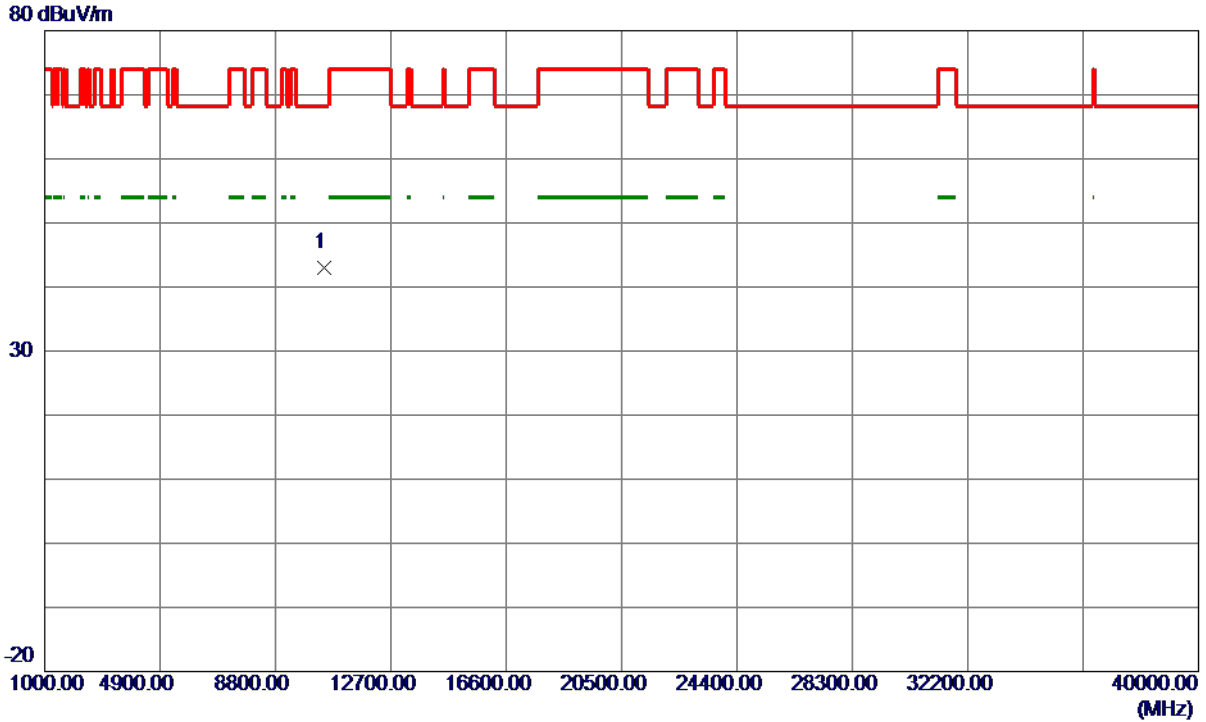

No.	Freq. MHz	Reading Level dBuV/m	Correct Factor dB	Measure ment dBuV/m	Limit dBuV/m	Margin dB	Detector	Comment
1 *	10438.7750	34.00	9.04	43.04	68.30	-25.26	Peak	

**REMARKS:**

- (1) Measurement Value = Reading Level + Correct Factor.
- (2) Margin Level = Measurement Value - Limit Value.

Orthogonal Axis	X
Test Mode	UNII-3_TX AC (VHT20) Mode 5745 MHz

### Vertical

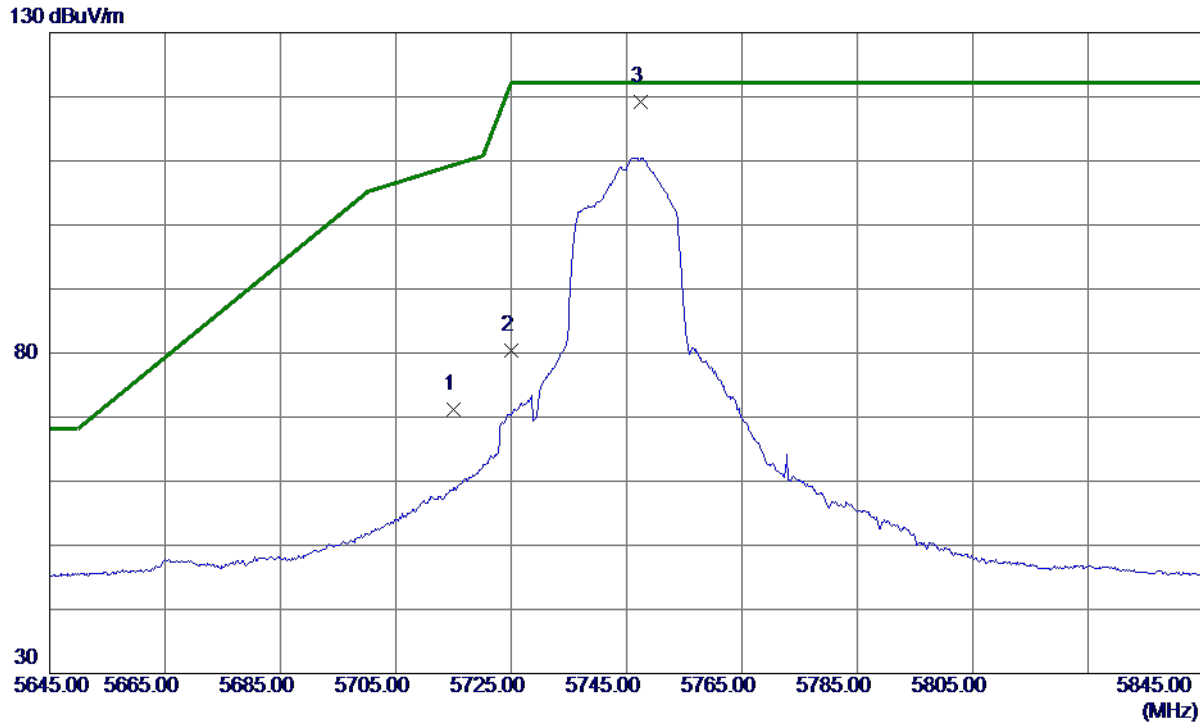

No.	Freq. MHz	Reading Level dBuV/m	Correct Factor dB	Measure ment dBuV/m	Limit dBuV/m	Margin dB	Detector	Comment
1	5715.0000	55.64	15.65	71.29	109.40	-38.11	Peak	
2	5725.0000	64.70	15.67	80.37	122.20	-41.83	Peak	
3 *	5747.5000	103.40	15.71	119.11	122.20	-3.09	Peak	No Limit

**REMARKS:**

- (1) Measurement Value = Reading Level + Correct Factor.
- (2) Margin Level = Measurement Value - Limit Value.

Orthogonal Axis	X
Test Mode	UNII-3_TX AC (VHT20) Mode 5745 MHz

### Vertical

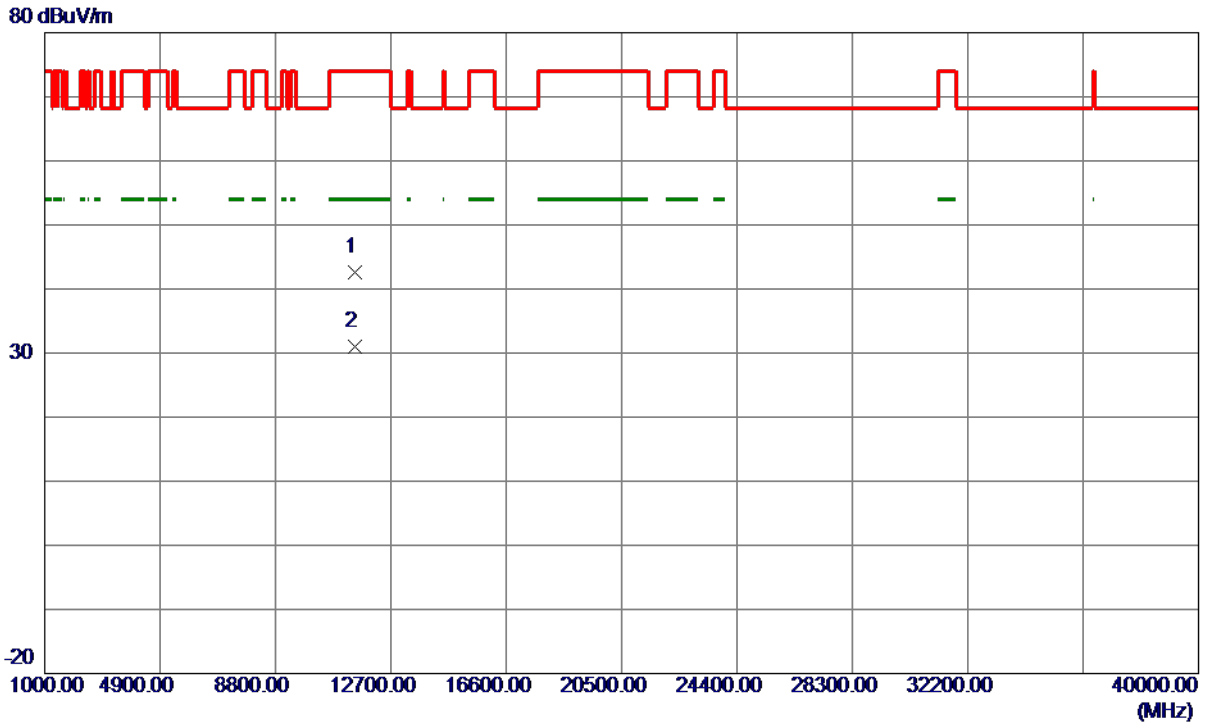

No.	Freq. MHz	Reading Level dBuV/m	Correct Factor dB	Measure ment dBuV/m	Limit dBuV/m	Margin dB	Detector	Comment
1	11498.3750	31.81	10.73	42.54	74.00	-31.46	Peak	
2 *	11498.4250	20.25	10.73	30.98	54.00	-23.02	AVG	

**REMARKS:**

- (1) Measurement Value = Reading Level + Correct Factor.
- (2) Margin Level = Measurement Value - Limit Value.

Orthogonal Axis	X
Test Mode	UNII-3_TX AC (VHT20) Mode 5745 MHz

### Horizontal

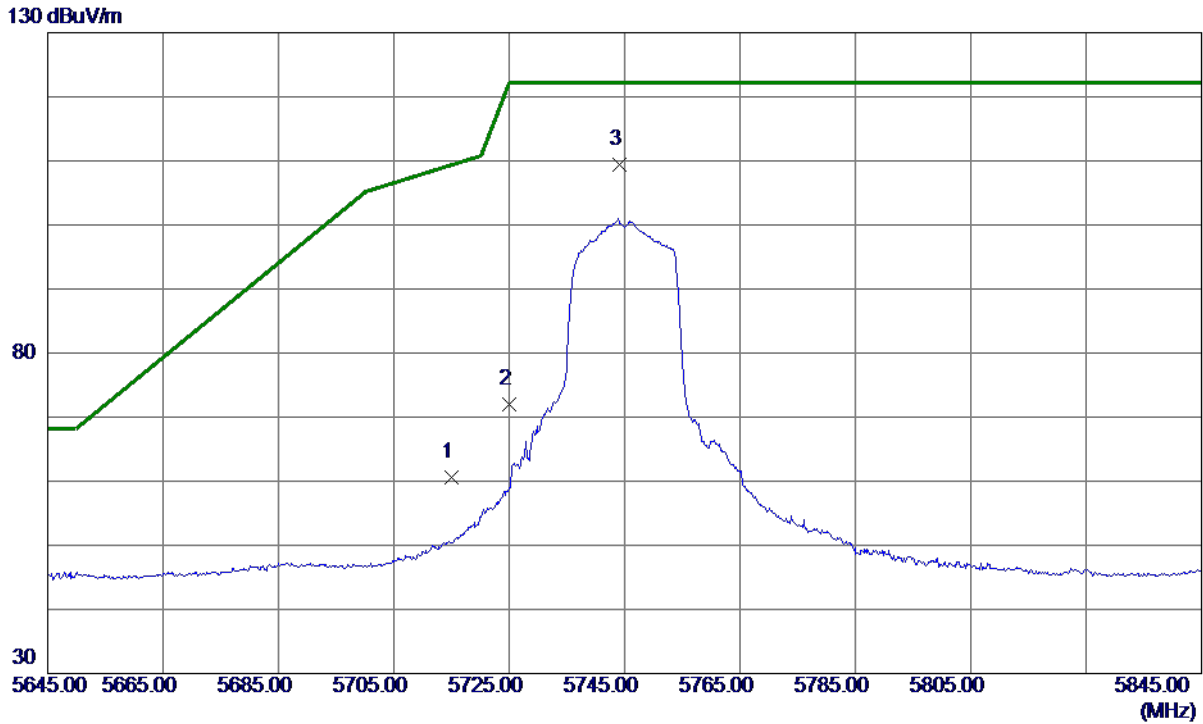

No.	Freq. MHz	Reading Level dBuV/m	Correct Factor dB	Measure ment dBuV/m	Limit dBuV/m	Margin dB	Detector	Comment
1	5715.0000	45.01	15.65	60.66	109.40	-48.74	Peak	
2	5725.0000	56.39	15.67	72.06	122.20	-50.14	Peak	
3 *	5744.1000	93.76	15.70	109.46	122.20	-12.74	Peak	No Limit

**REMARKS:**

- (1) Measurement Value = Reading Level + Correct Factor.
- (2) Margin Level = Measurement Value - Limit Value.

Orthogonal Axis	X
Test Mode	UNII-3_TX AC (VHT20) Mode 5745 MHz

### Horizontal

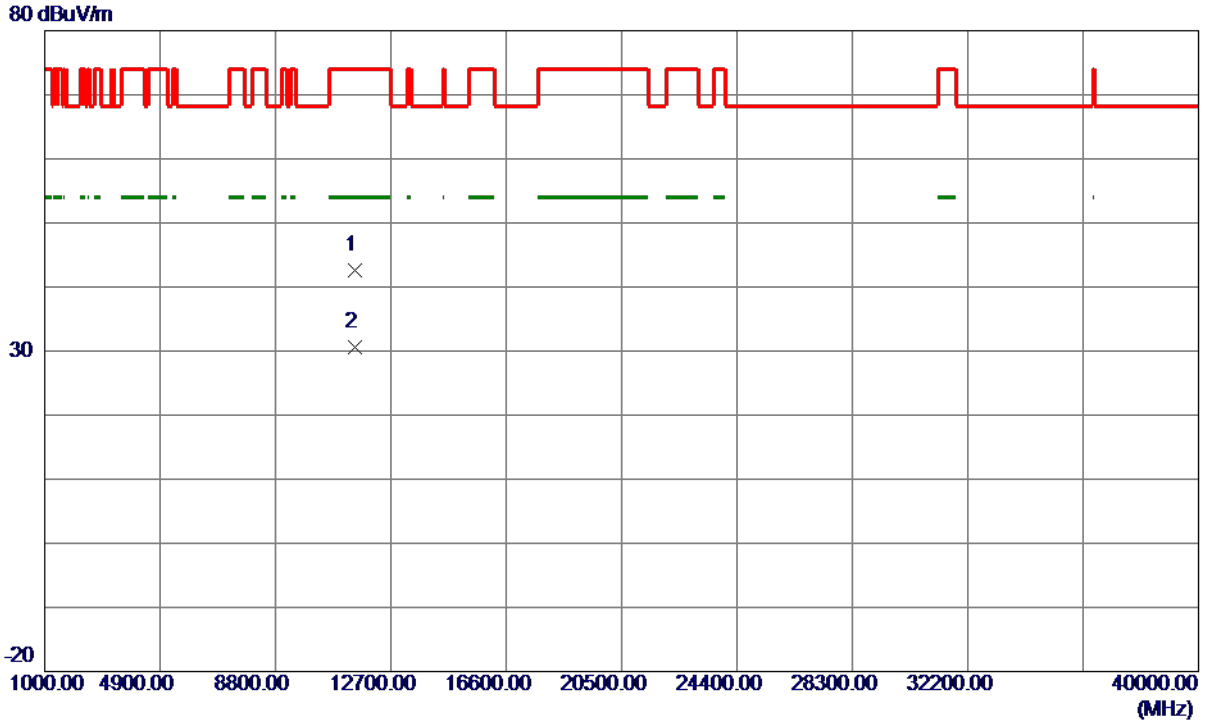

No.	Freq. MHz	Reading Level dBuV/m	Correct Factor dB	Measure ment dBuV/m	Limit dBuV/m	Margin dB	Detector	Comment
1	11488.9750	31.88	10.71	42.59	74.00	-31.41	Peak	
2 *	11507.7750	19.94	10.74	30.68	54.00	-23.32	AVG	

**REMARKS:**

- (1) Measurement Value = Reading Level + Correct Factor.
- (2) Margin Level = Measurement Value - Limit Value.

Orthogonal Axis	X
Test Mode	UNII-3_TX AC (VHT20) Mode 5785 MHz

### Vertical

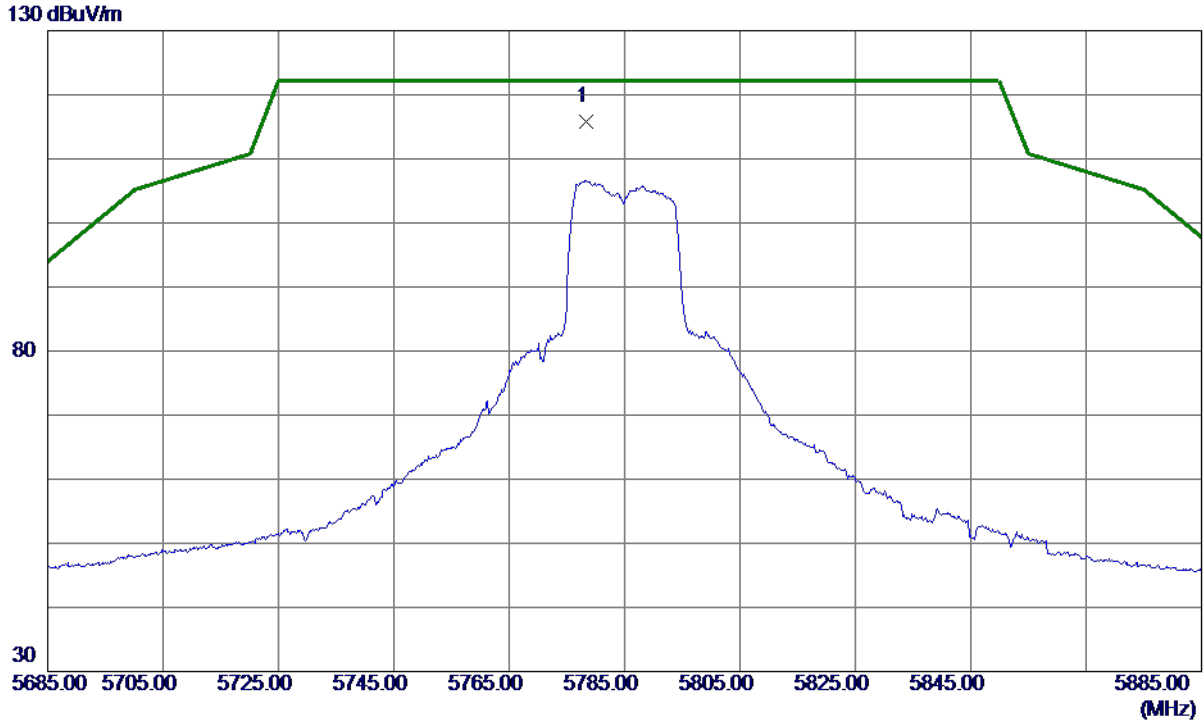

No.	Freq. MHz	Reading Level dBuV/m	Correct Factor dB	Measure ment dBuV/m	Limit dBuV/m	Margin dB	Detector	Comment
1 *	5778.4000	100.09	15.77	115.86	122.20	-6.34	Peak	No Limit

**REMARKS:**

- (1) Measurement Value = Reading Level + Correct Factor.
- (2) Margin Level = Measurement Value - Limit Value.

Orthogonal Axis	X
Test Mode	UNII-3_TX AC (VHT20) Mode 5785 MHz

### Vertical

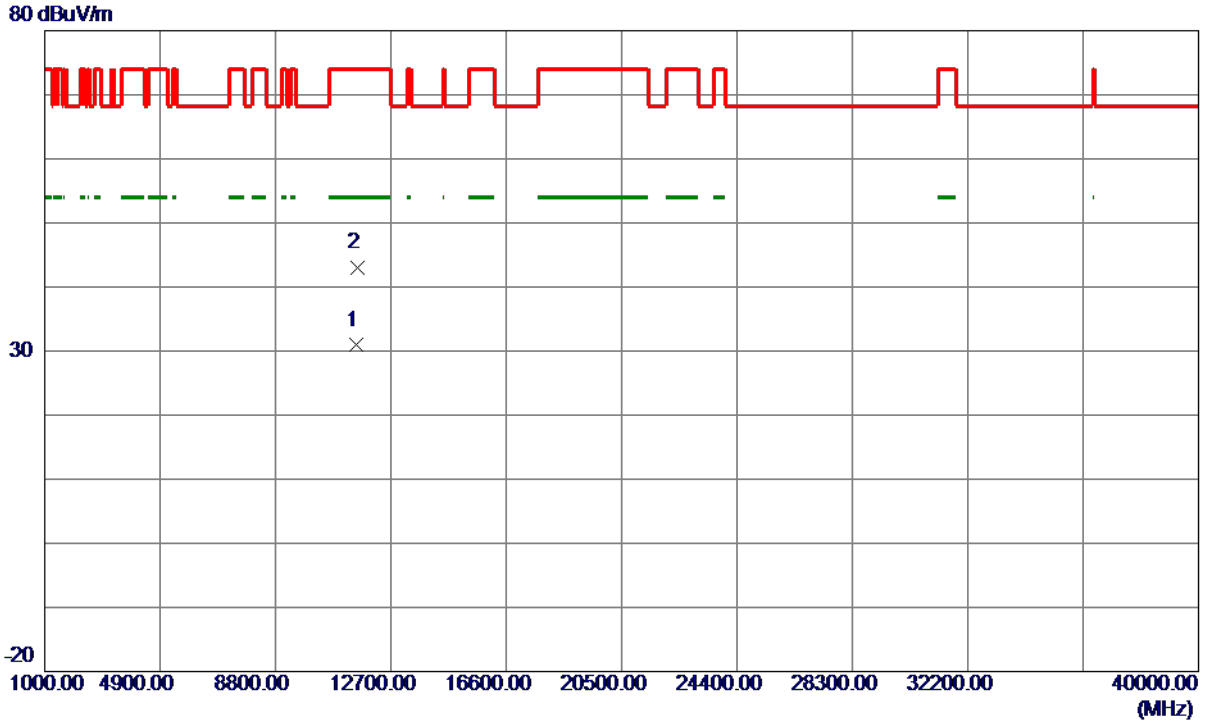

No.	Freq. MHz	Reading Level dBuV/m	Correct Factor dB	Measure ment dBuV/m	Limit dBuV/m	Margin dB	Detector	Comment
1 *	11551.1750	20.07	10.83	30.90	54.00	-23.10	AVG	
2	11575.0750	32.08	10.87	42.95	74.00	-31.05	Peak	

**REMARKS:**

- (1) Measurement Value = Reading Level + Correct Factor.
- (2) Margin Level = Measurement Value - Limit Value.



Orthogonal Axis	X
Test Mode	UNII-3_TX AC (VHT20) Mode 5785 MHz

### Horizontal

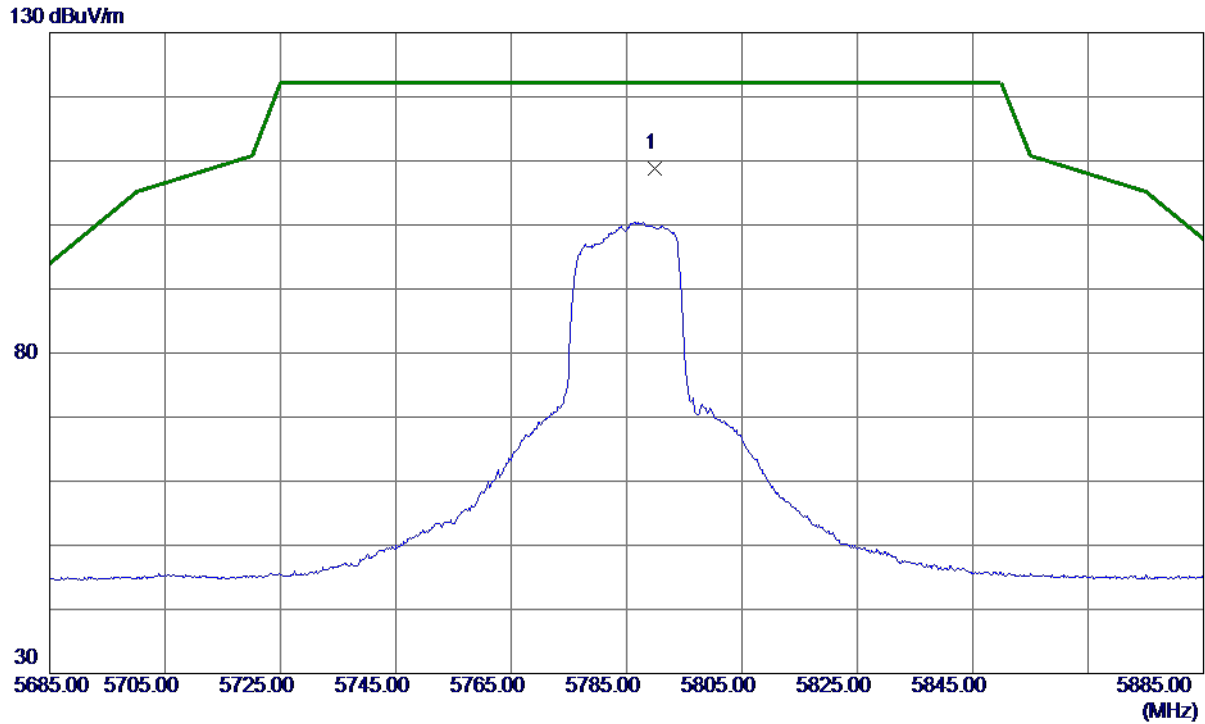

No.	Freq. MHz	Reading Level dBuV/m	Correct Factor dB	Measure ment dBuV/m	Limit dBuV/m	Margin dB	Detector	Comment
1 *	5789.9000	92.92	15.79	108.71	122.20	-13.49	Peak	No Limit

**REMARKS:**

- (1) Measurement Value = Reading Level + Correct Factor.
- (2) Margin Level = Measurement Value - Limit Value.

Orthogonal Axis	X
Test Mode	UNII-3_TX AC (VHT20) Mode 5785 MHz

### Horizontal

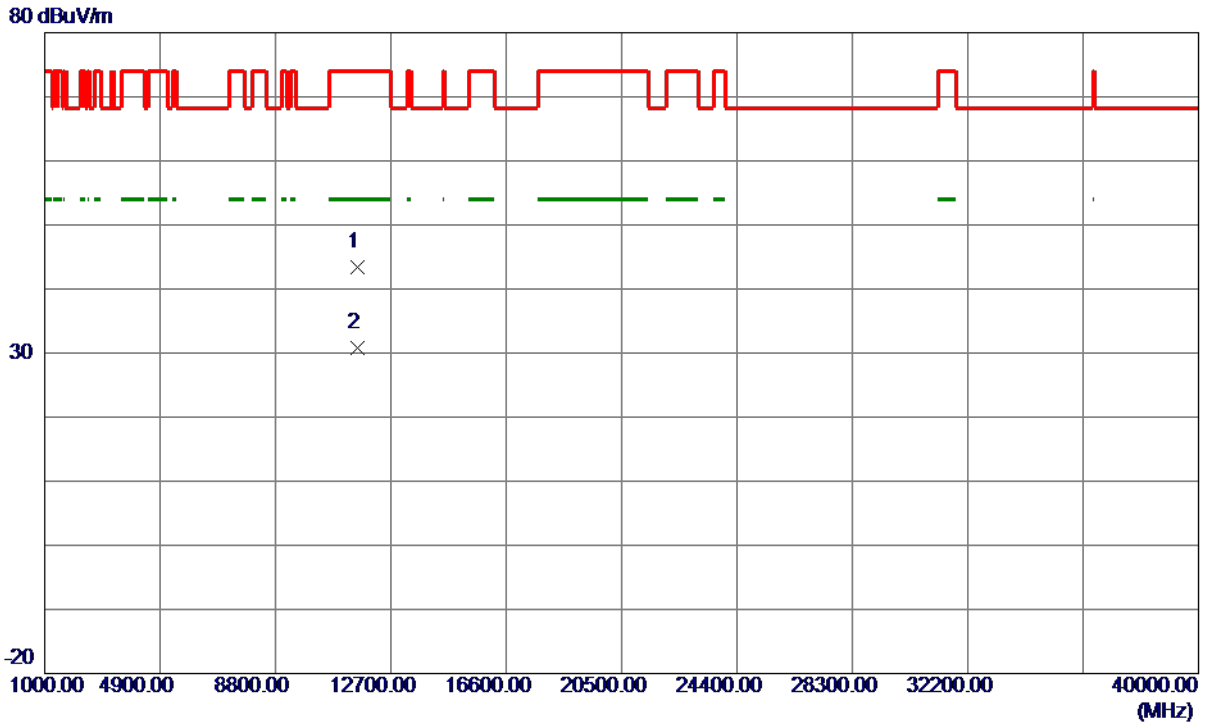

No.	Freq. MHz	Reading Level dBuV/m	Correct Factor dB	Measure ment dBuV/m	Limit dBuV/m	Margin dB	Detector	Comment
1	11573.5500	32.62	10.87	43.49	74.00	-30.51	Peak	
2 *	11577.2750	19.90	10.88	30.78	54.00	-23.22	AVG	

**REMARKS:**

- (1) Measurement Value = Reading Level + Correct Factor.
- (2) Margin Level = Measurement Value - Limit Value.

Orthogonal Axis	X
Test Mode	UNII-3_TX AC (VHT20) Mode 5825 MHz

### Vertical

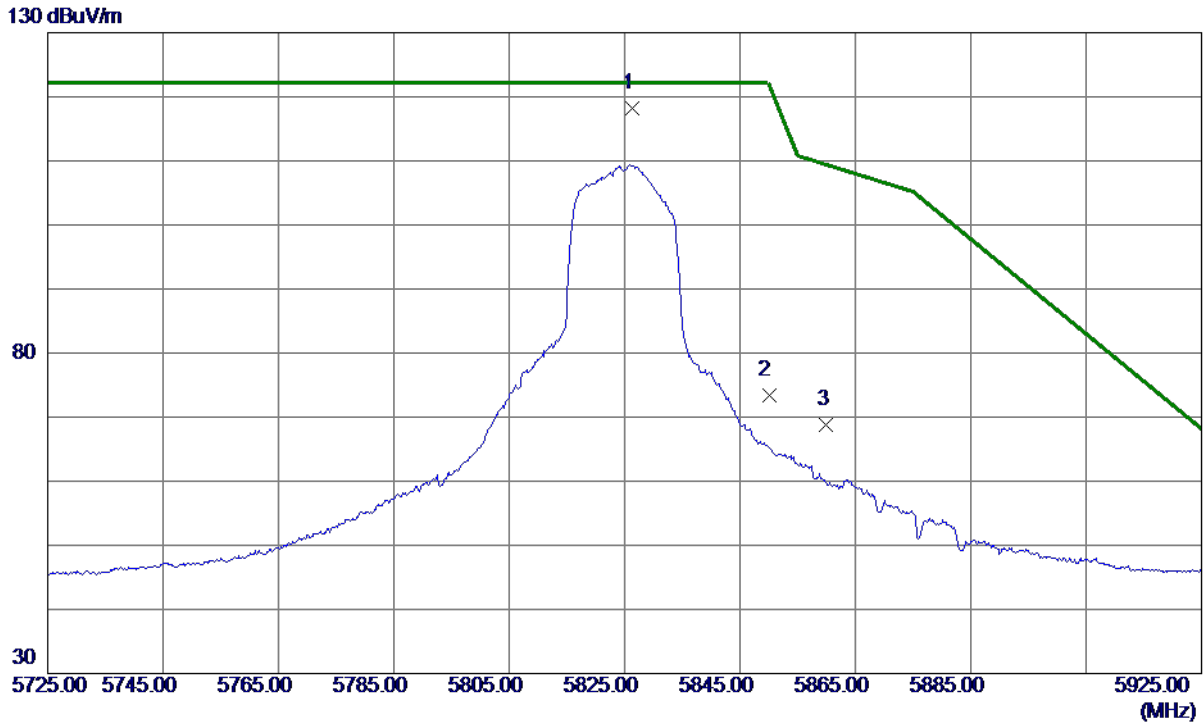

No.	Freq. MHz	Reading Level dBuV/m	Correct Factor dB	Measure ment dBuV/m	Limit dBuV/m	Margin dB	Detector	Comment
1 *	5826.3000	102.36	15.85	118.21	122.20	-3.99	Peak	No Limit
2	5850.0000	57.44	15.90	73.34	122.20	-48.86	Peak	
3	5860.0000	52.90	15.92	68.82	109.40	-40.58	Peak	

**REMARKS:**

- (1) Measurement Value = Reading Level + Correct Factor.
- (2) Margin Level = Measurement Value - Limit Value.

Orthogonal Axis	X
Test Mode	UNII-3_TX AC (VHT20) Mode 5825 MHz

### Vertical

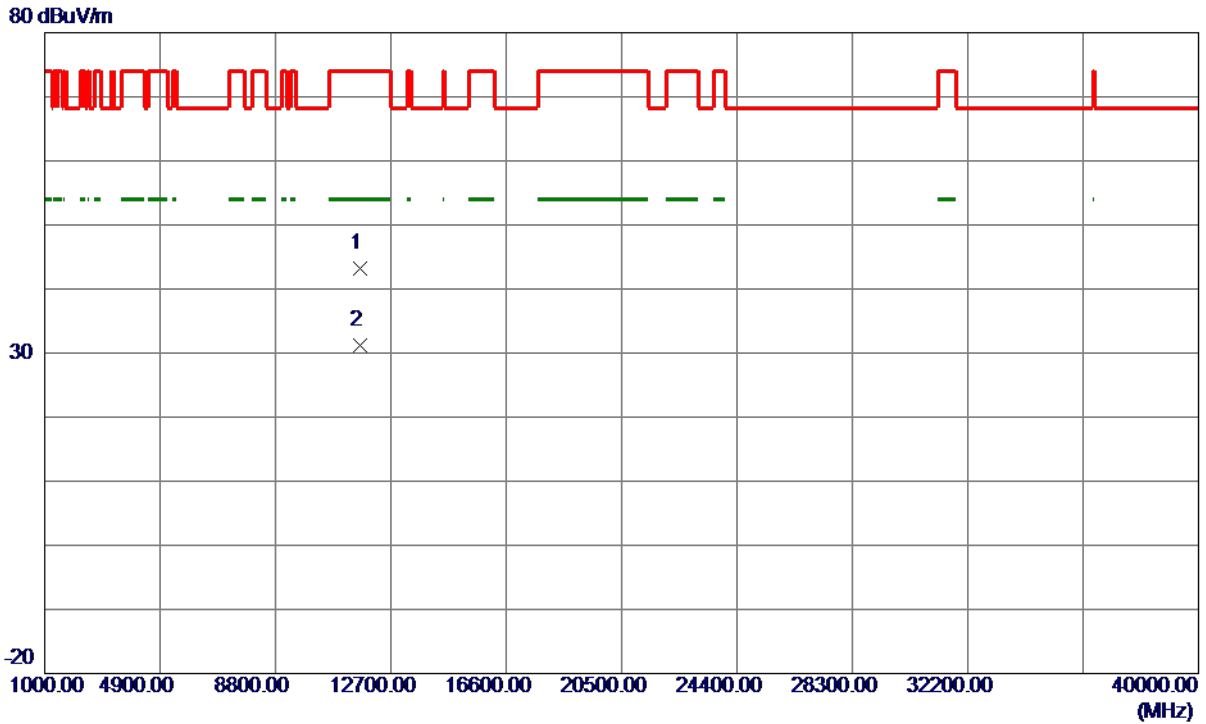

No.	Freq. MHz	Reading Level dBuV/m	Correct Factor dB	Measure ment dBuV/m	Limit dBuV/m	Margin dB	Detector	Comment
1	11653.0000	32.22	11.02	43.24	74.00	-30.76	Peak	
2 *	11667.0000	20.23	11.05	31.28	54.00	-22.72	AVG	

**REMARKS:**

- (1) Measurement Value = Reading Level + Correct Factor.
- (2) Margin Level = Measurement Value - Limit Value.

Orthogonal Axis	X
Test Mode	UNII-3_TX AC (VHT20) Mode 5825 MHz

### Horizontal

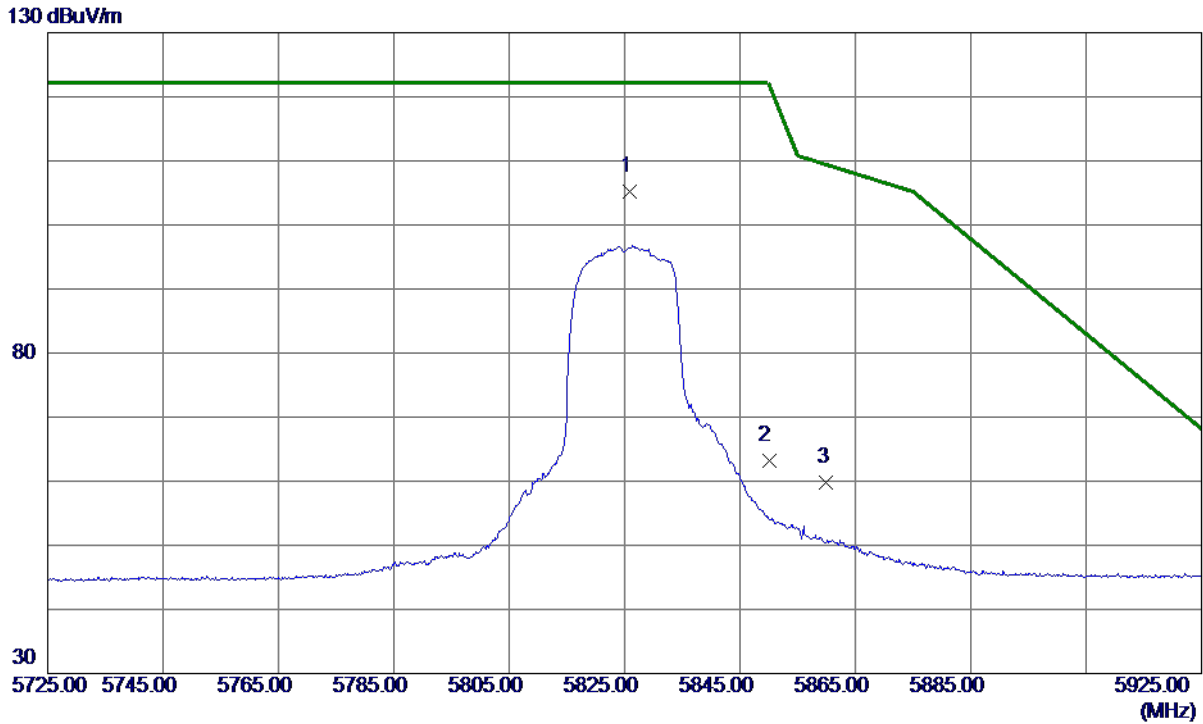

No.	Freq. MHz	Reading Level dBuV/m	Correct Factor dB	Measure ment dBuV/m	Limit dBuV/m	Margin dB	Detector	Comment
1 *	5825.8000	89.30	15.85	105.15	122.20	-17.05	Peak	No Limit
2	5850.0000	47.28	15.90	63.18	122.20	-59.02	Peak	
3	5860.0000	43.81	15.92	59.73	109.40	-49.67	Peak	

**REMARKS:**

- (1) Measurement Value = Reading Level + Correct Factor.
- (2) Margin Level = Measurement Value - Limit Value.

Orthogonal Axis	X
Test Mode	UNII-3_TX AC (VHT20) Mode 5825 MHz

### Horizontal

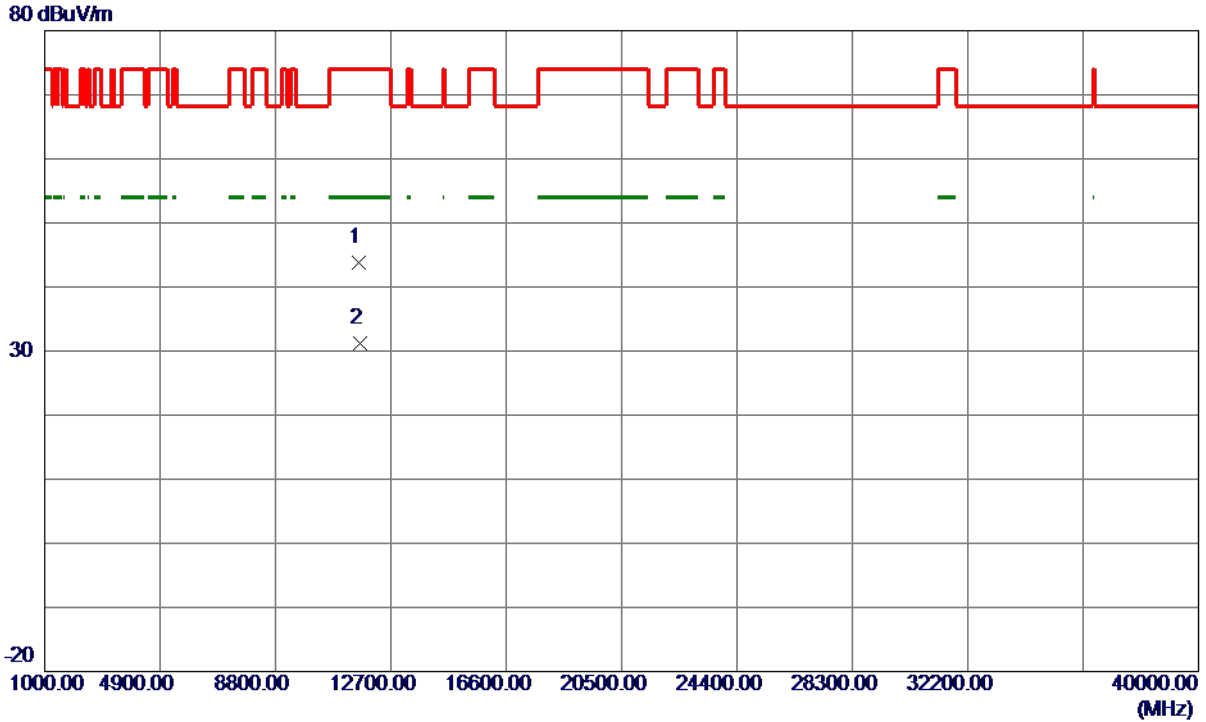

No.	Freq. MHz	Reading Level dBuV/m	Correct Factor dB	Measure ment dBuV/m	Limit dBuV/m	Margin dB	Detector	Comment
1	11629.2000	32.81	10.98	43.79	74.00	-30.21	Peak	
2 *	11667.4000	20.21	11.05	31.26	54.00	-22.74	AVG	

**REMARKS:**

- (1) Measurement Value = Reading Level + Correct Factor.
- (2) Margin Level = Measurement Value - Limit Value.

Orthogonal Axis	X
Test Mode	UNII-3_TX AC (VHT40) Mode 5755 MHz

### Vertical

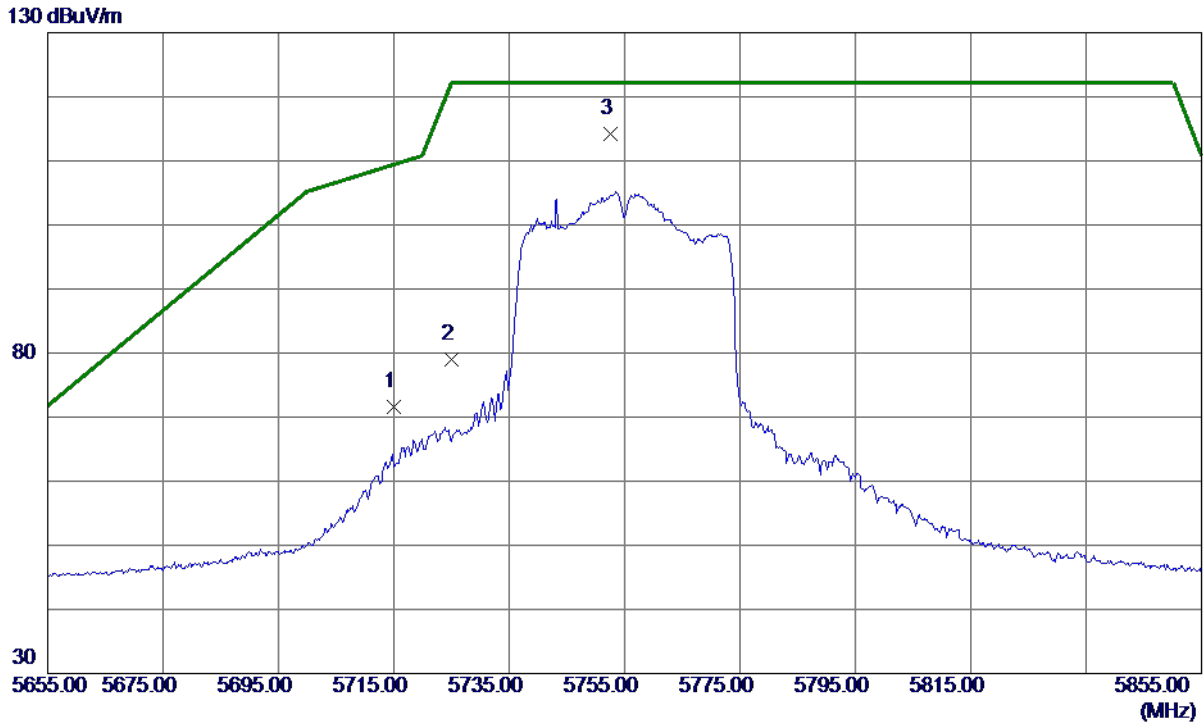

No.	Freq. MHz	Reading Level dBuV/m	Correct Factor dB	Measure ment dBuV/m	Limit dBuV/m	Margin dB	Detector	Comment
1	5715.0000	55.88	15.65	71.53	109.40	-37.87	Peak	
2	5725.0000	63.29	15.67	78.96	122.20	-43.24	Peak	
3 *	5752.5000	98.55	15.72	114.27	122.20	-7.93	Peak	No Limit

**REMARKS:**

- (1) Measurement Value = Reading Level + Correct Factor.
- (2) Margin Level = Measurement Value - Limit Value.

Orthogonal Axis	X
Test Mode	UNII-3_TX AC (VHT40) Mode 5755 MHz

### Vertical

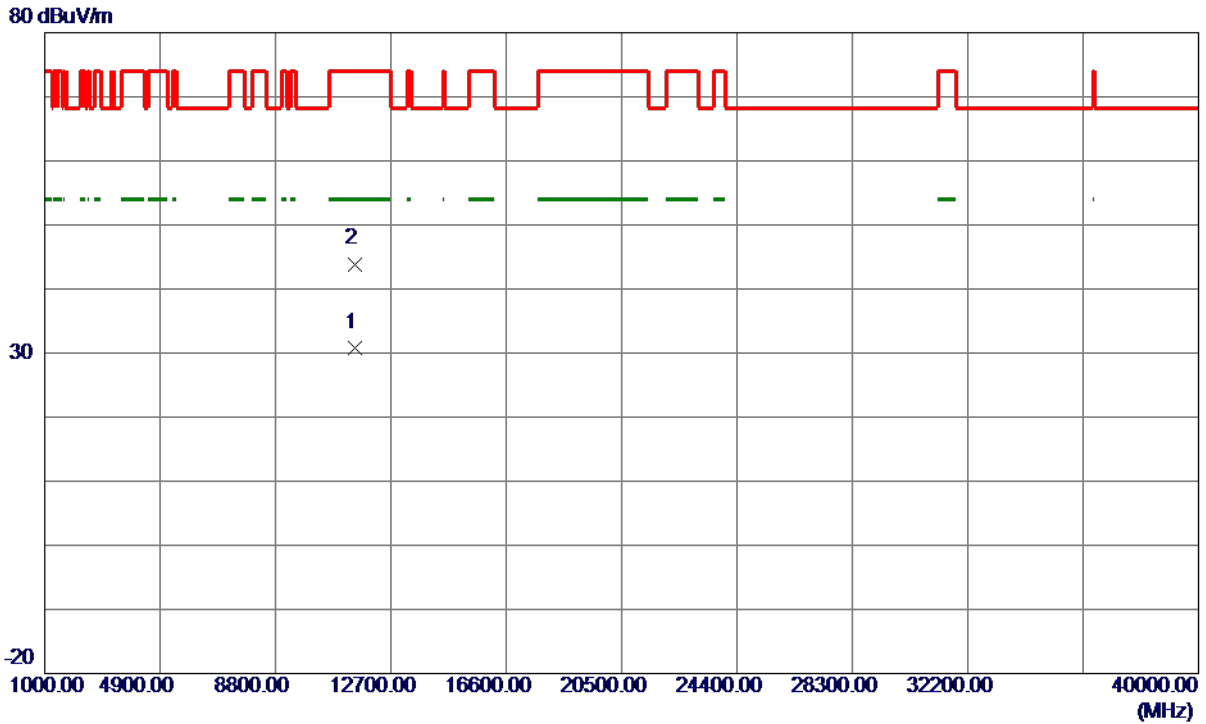

No.	Freq. MHz	Reading Level dBuV/m	Correct Factor dB	Measure ment dBuV/m	Limit dBuV/m	Margin dB	Detector	Comment
1 *	11499.2750	20.06	10.73	30.79	54.00	-23.21	AVG	
2	11504.9750	33.16	10.74	43.90	74.00	-30.10	Peak	

**REMARKS:**

- (1) Measurement Value = Reading Level + Correct Factor.
- (2) Margin Level = Measurement Value - Limit Value.



Orthogonal Axis	X
Test Mode	UNII-3_TX AC (VHT40) Mode 5755 MHz

### Horizontal

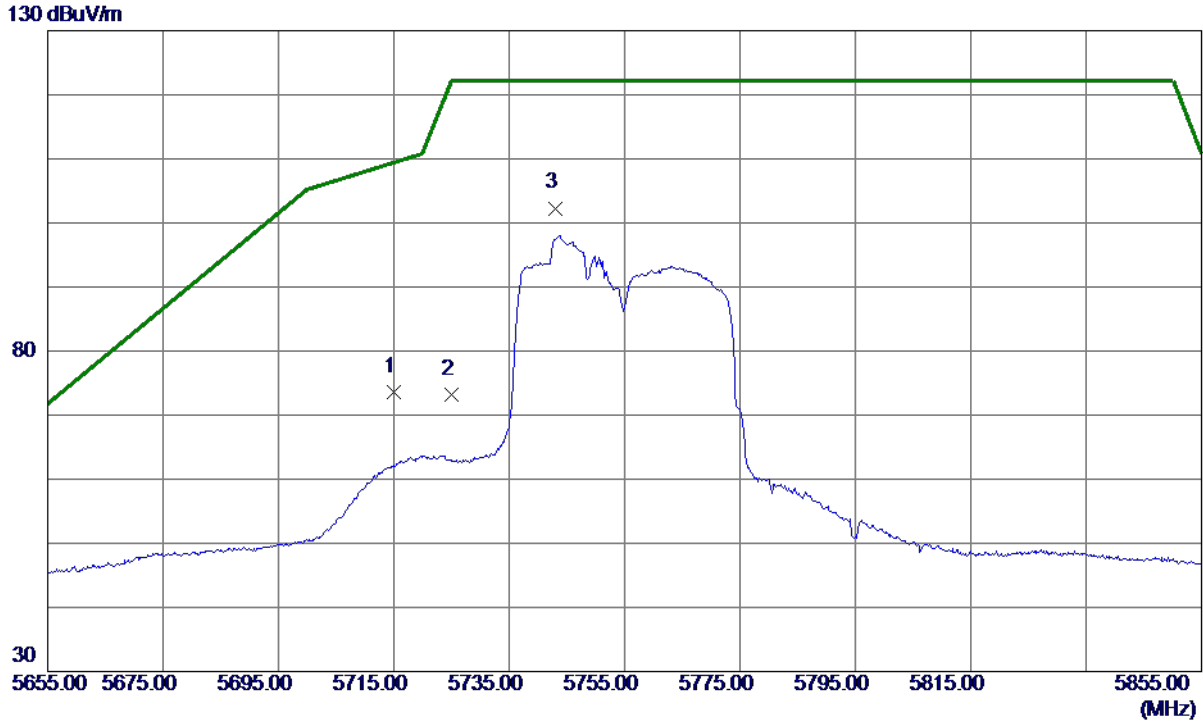

No.	Freq. MHz	Reading Level dBuV/m	Correct Factor dB	Measure ment dBuV/m	Limit dBuV/m	Margin dB	Detector	Comment
1	5715.0000	57.87	15.65	73.52	109.40	-35.88	Peak	
2	5725.0000	57.62	15.67	73.29	122.20	-48.91	Peak	
3 *	5742.9000	86.60	15.70	102.30	122.20	-19.90	Peak	No Limit

**REMARKS:**

- (1) Measurement Value = Reading Level + Correct Factor.
- (2) Margin Level = Measurement Value - Limit Value.

Orthogonal Axis	X
Test Mode	UNII-3_TX AC (VHT40) Mode 5755 MHz

### Horizontal

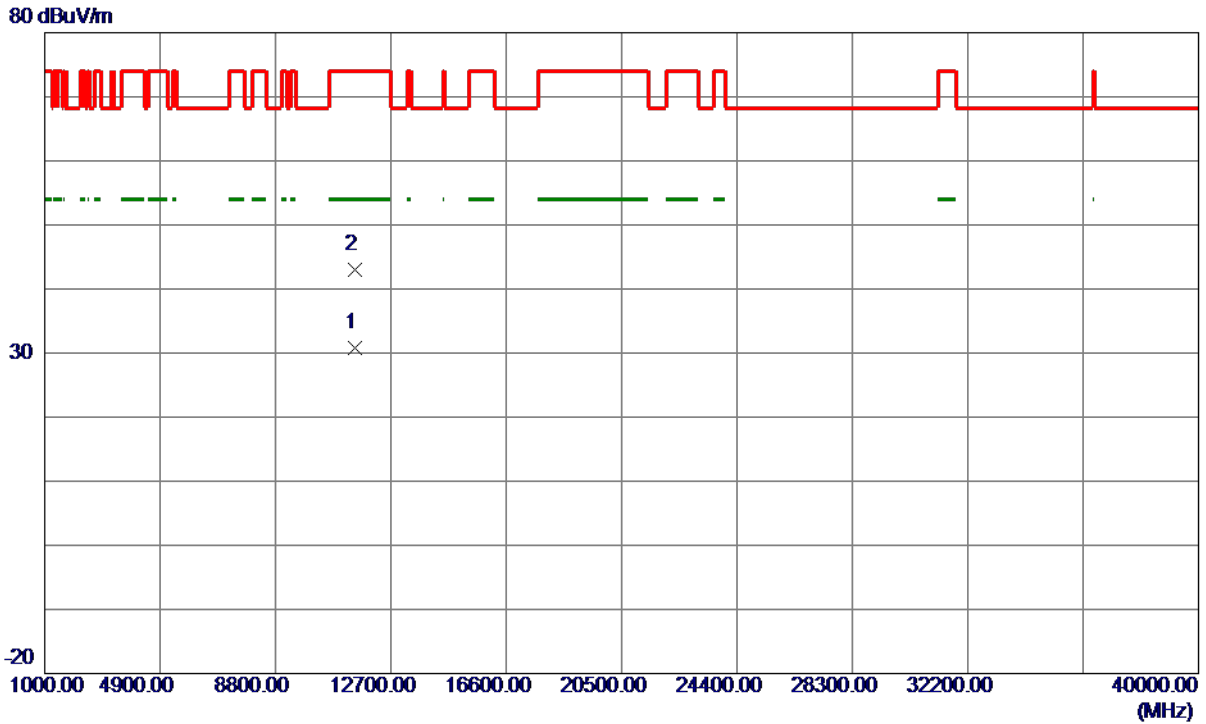

No.	Freq. MHz	Reading Level dBuV/m	Correct Factor dB	Measure ment dBuV/m	Limit dBuV/m	Margin dB	Detector	Comment
1 *	11494.9250	20.07	10.72	30.79	54.00	-23.21	AVG	
2	11499.1000	32.19	10.73	42.92	74.00	-31.08	Peak	

**REMARKS:**

- (1) Measurement Value = Reading Level + Correct Factor.
- (2) Margin Level = Measurement Value - Limit Value.

Orthogonal Axis	X
Test Mode	UNII-3_TX AC (VHT40) Mode 5795 MHz

### Vertical

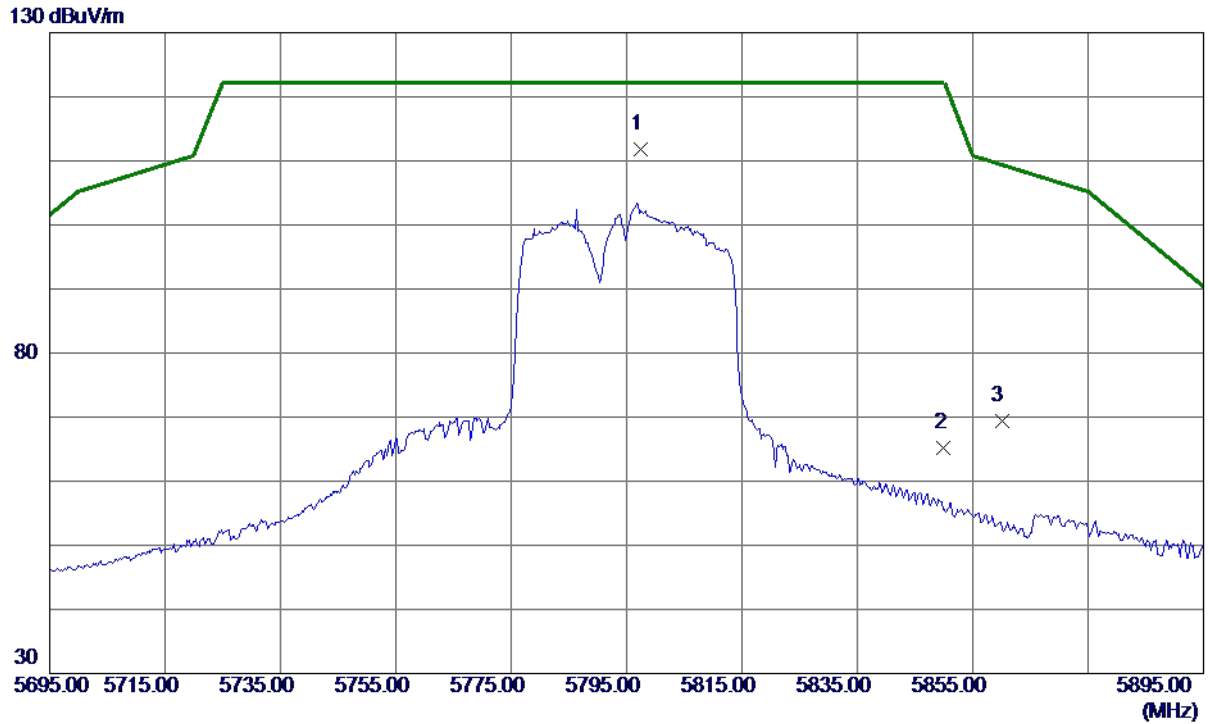

No.	Freq. MHz	Reading Level dBuV/m	Correct Factor dB	Measure ment dBuV/m	Limit dBuV/m	Margin dB	Detector	Comment
1 *	5797.5000	95.96	15.80	111.76	122.20	-10.44	Peak	No Limit
2	5850.0000	49.36	15.90	65.26	122.20	-56.94	Peak	
3	5860.0000	53.54	15.92	69.46	109.40	-39.94	Peak	

**REMARKS:**

- (1) Measurement Value = Reading Level + Correct Factor.
- (2) Margin Level = Measurement Value - Limit Value.

Orthogonal Axis	X
Test Mode	UNII-3_TX AC (VHT40) Mode 5795 MHz

### Vertical

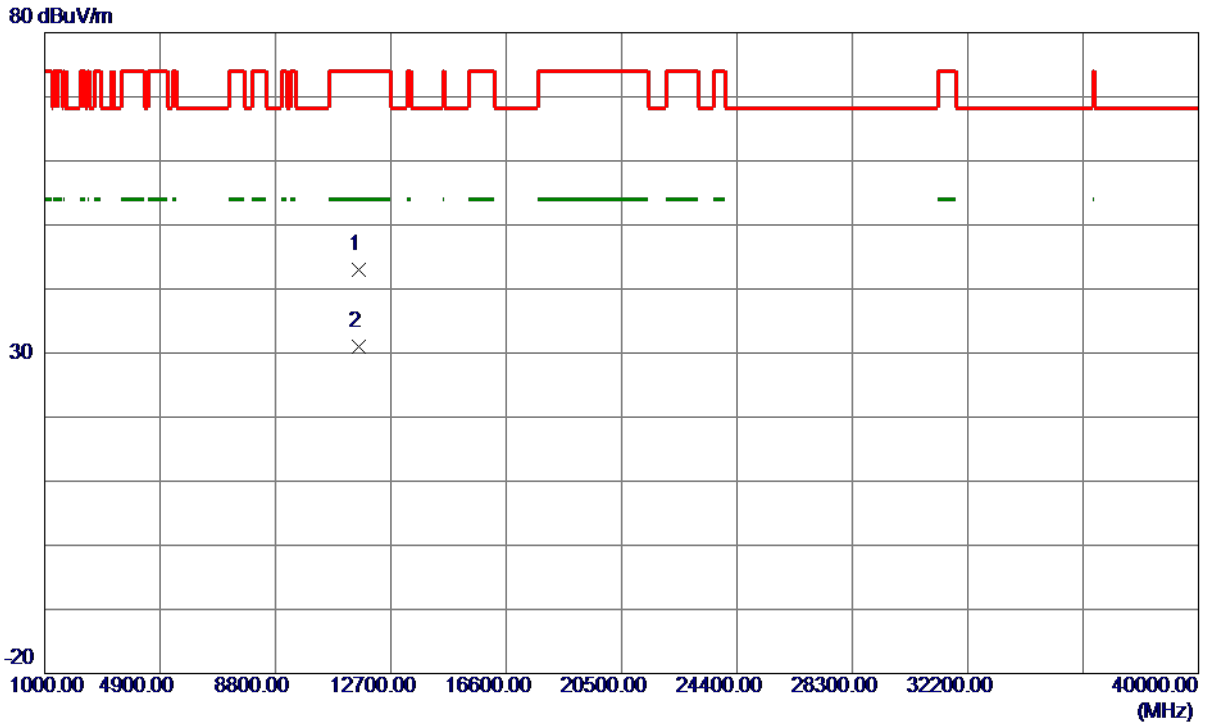

No.	Freq. MHz	Reading Level dBuV/m	Correct Factor dB	Measure ment dBuV/m	Limit dBuV/m	Margin dB	Detector	Comment
1	11600.0250	32.03	10.92	42.95	74.00	-31.05	Peak	
2 *	11614.8000	20.00	10.95	30.95	54.00	-23.05	AVG	

**REMARKS:**

- (1) Measurement Value = Reading Level + Correct Factor.
- (2) Margin Level = Measurement Value - Limit Value.

Orthogonal Axis	X
Test Mode	UNII-3_TX AC (VHT40) Mode 5795 MHz

### Horizontal

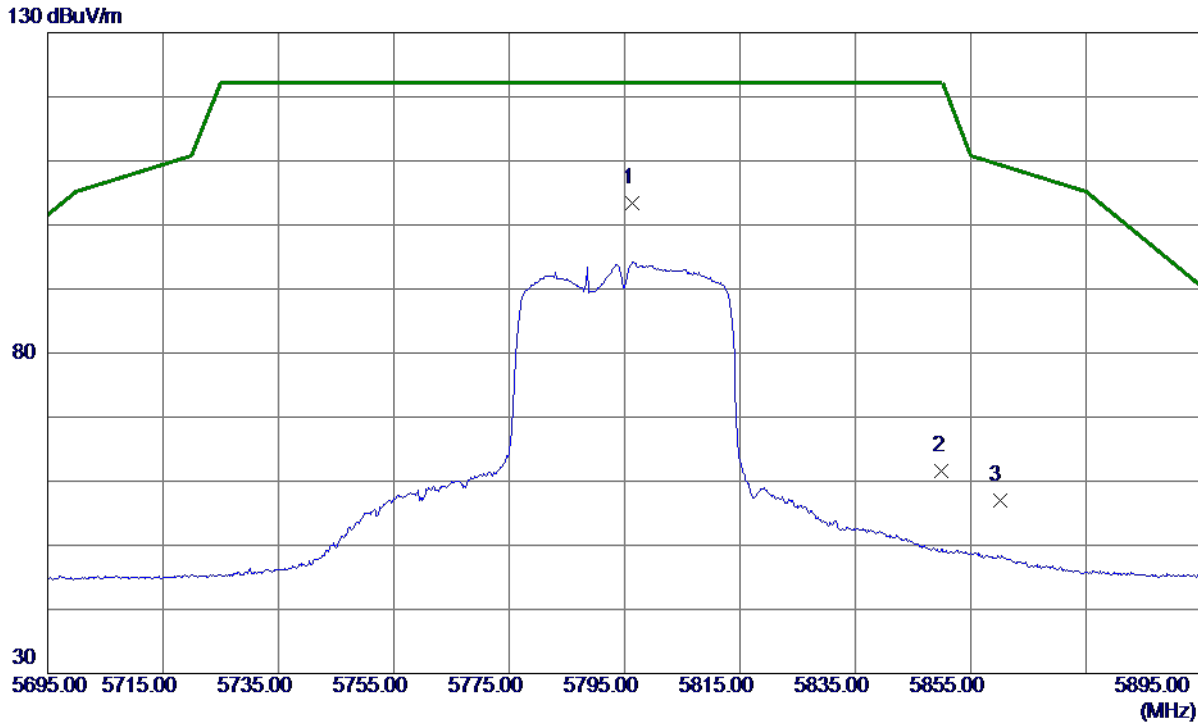

No.	Freq. MHz	Reading Level dBuV/m	Correct Factor dB	Measure ment dBuV/m	Limit dBuV/m	Margin dB	Detector	Comment
1 *	5796.4000	87.67	15.80	103.47	122.20	-18.73	Peak	No Limit
2	5850.0000	45.61	15.90	61.51	122.20	-60.69	Peak	
3	5860.0000	40.99	15.92	56.91	109.40	-52.49	Peak	

**REMARKS:**

- (1) Measurement Value = Reading Level + Correct Factor.
- (2) Margin Level = Measurement Value - Limit Value.

Orthogonal Axis	X
Test Mode	UNII-3_TX AC (VHT40) Mode 5795 MHz

### Horizontal

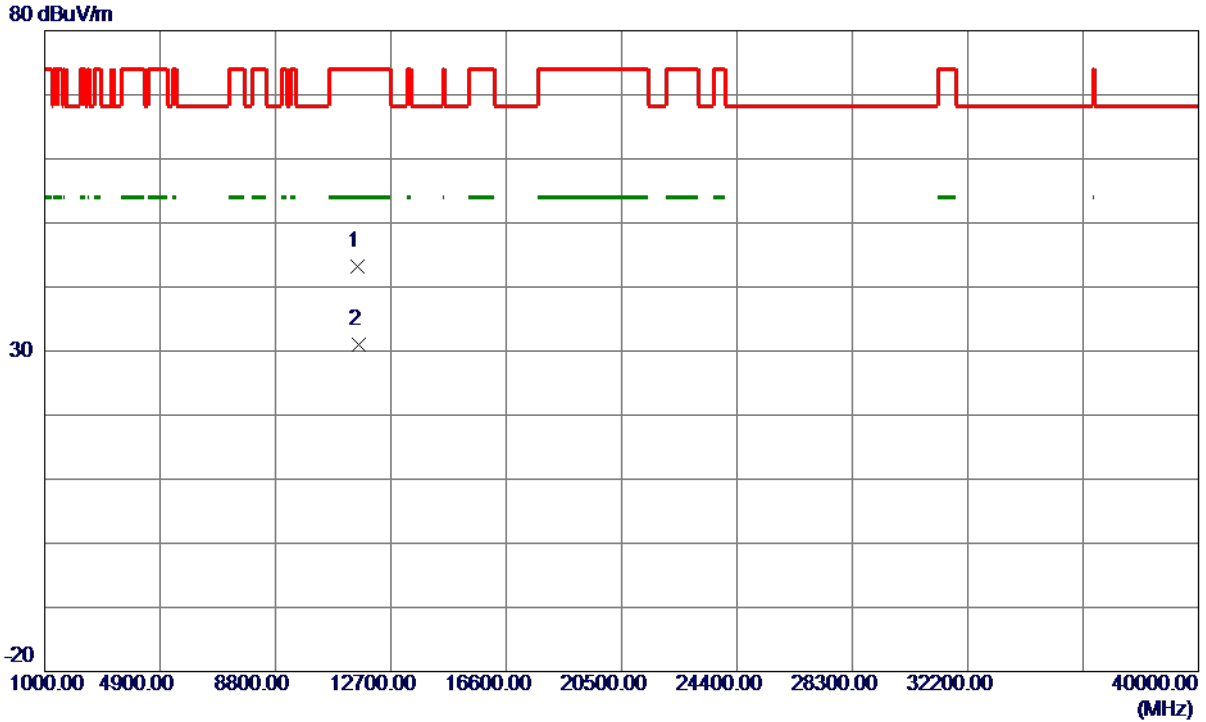

No.	Freq. MHz	Reading Level dBuV/m	Correct Factor dB	Measure ment dBuV/m	Limit dBuV/m	Margin dB	Detector	Comment
1	11583.4750	32.35	10.89	43.24	74.00	-30.76	Peak	
2 *	11613.5000	20.03	10.95	30.98	54.00	-23.02	AVG	

**REMARKS:**

- (1) Measurement Value = Reading Level + Correct Factor.
- (2) Margin Level = Measurement Value - Limit Value.

Orthogonal Axis	X
Test Mode	UNII-3_TX AC (VHT80) Mode 5775 MHz

### Vertical

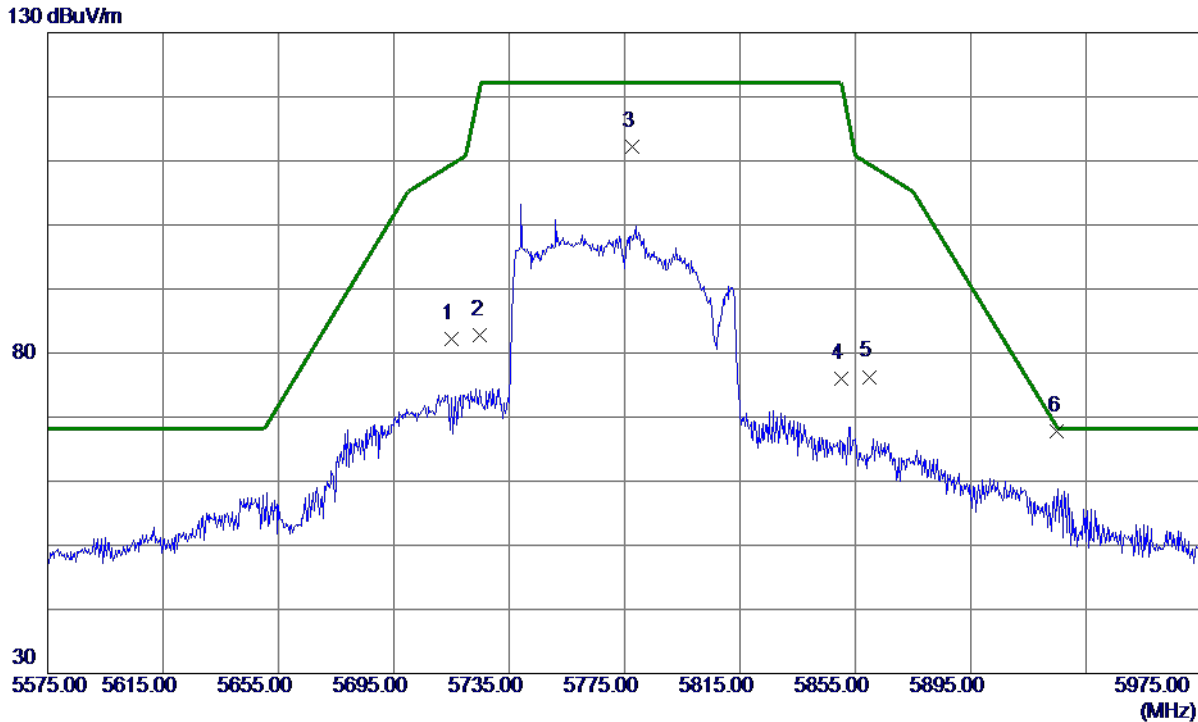

No.	Freq. MHz	Reading Level dBuV/m	Correct Factor dB	Measure ment dBuV/m	Limit dBuV/m	Margin dB	Detector	Comment
1	5715.0000	66.57	15.65	82.22	109.40	-27.18	Peak	
2	5725.0000	67.10	15.67	82.77	122.20	-39.43	Peak	
3	5777.6000	96.37	15.77	112.14	122.20	-10.06	Peak	No Limit
4	5850.0000	60.16	15.90	76.06	122.20	-46.14	Peak	
5	5860.0000	60.38	15.92	76.30	109.40	-33.10	Peak	
6 *	5925.0000	51.86	16.03	67.89	68.20	-0.31	Peak	

**REMARKS:**

- (1) Measurement Value = Reading Level + Correct Factor.
- (2) Margin Level = Measurement Value - Limit Value.

Orthogonal Axis	X
Test Mode	UNII-3_TX AC (VHT80) Mode 5775 MHz

### Vertical

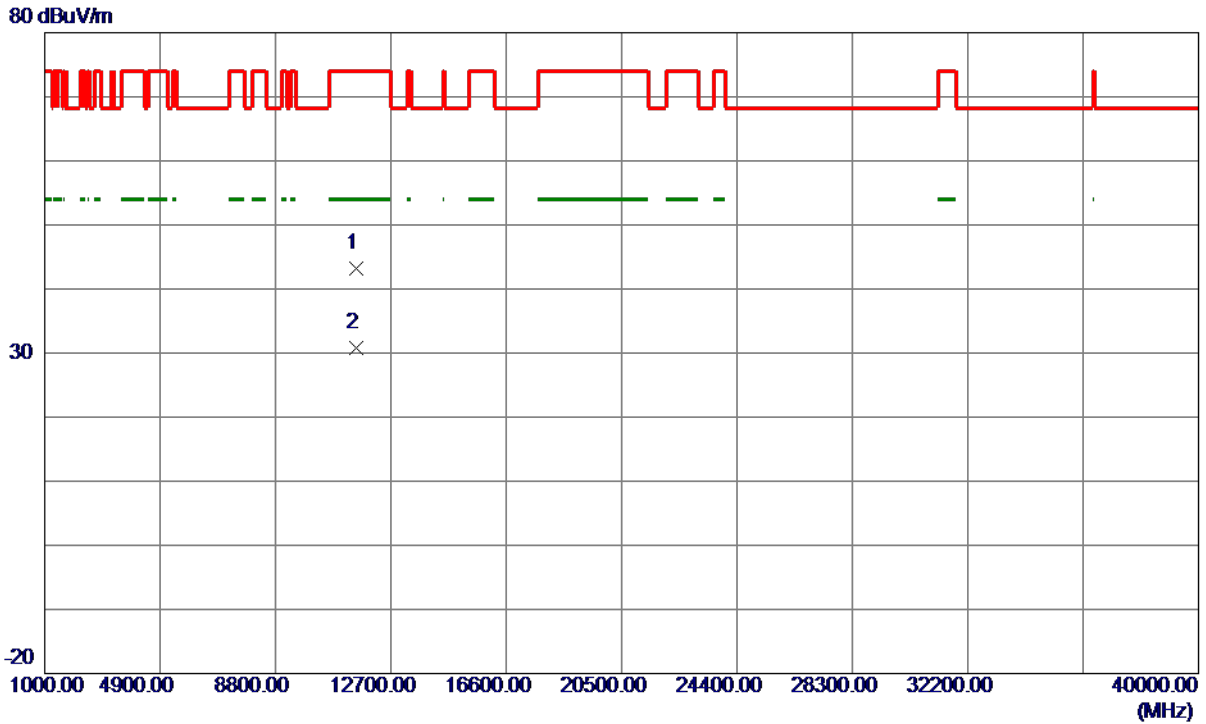

No.	Freq. MHz	Reading Level dBuV/m	Correct Factor dB	Measure ment dBuV/m	Limit dBuV/m	Margin dB	Detector	Comment
1	11533.4250	32.33	10.79	43.12	74.00	-30.88	Peak	
2 *	11533.9250	20.01	10.79	30.80	54.00	-23.20	AVG	

**REMARKS:**

- (1) Measurement Value = Reading Level + Correct Factor.
- (2) Margin Level = Measurement Value - Limit Value.



Orthogonal Axis	X
Test Mode	UNII-3_TX AC (VHT80) Mode 5775 MHz

### Horizontal

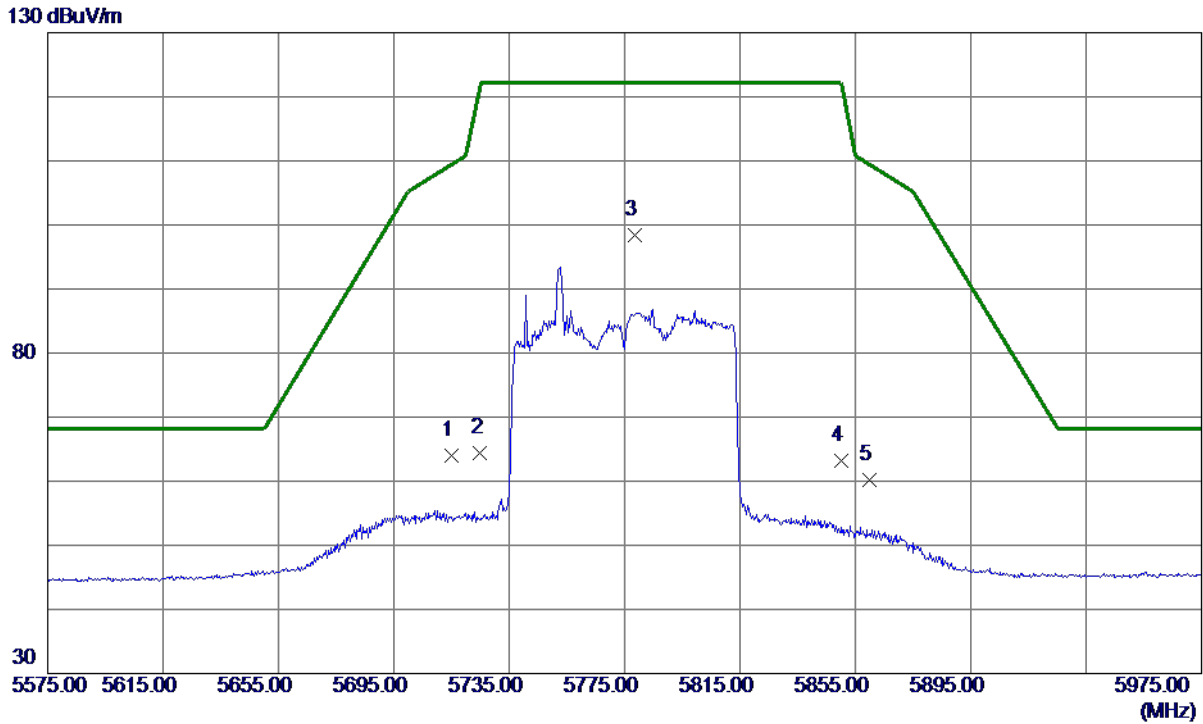

No.	Freq. MHz	Reading Level dBuV/m	Correct Factor dB	Measure ment dBuV/m	Limit dBuV/m	Margin dB	Detector	Comment
1	5715.0000	48.40	15.65	64.05	109.40	-45.35	Peak	
2	5725.0000	48.64	15.67	64.31	122.20	-57.89	Peak	
3 *	5778.4000	82.64	15.77	98.41	122.20	-23.79	Peak	No Limit
4	5850.0000	47.37	15.90	63.27	122.20	-58.93	Peak	
5	5860.0000	44.21	15.92	60.13	109.40	-49.27	Peak	

**REMARKS:**

- (1) Measurement Value = Reading Level + Correct Factor.
- (2) Margin Level = Measurement Value - Limit Value.

Orthogonal Axis	X
Test Mode	UNII-3_TX AC (VHT80) Mode 5775 MHz

### Horizontal

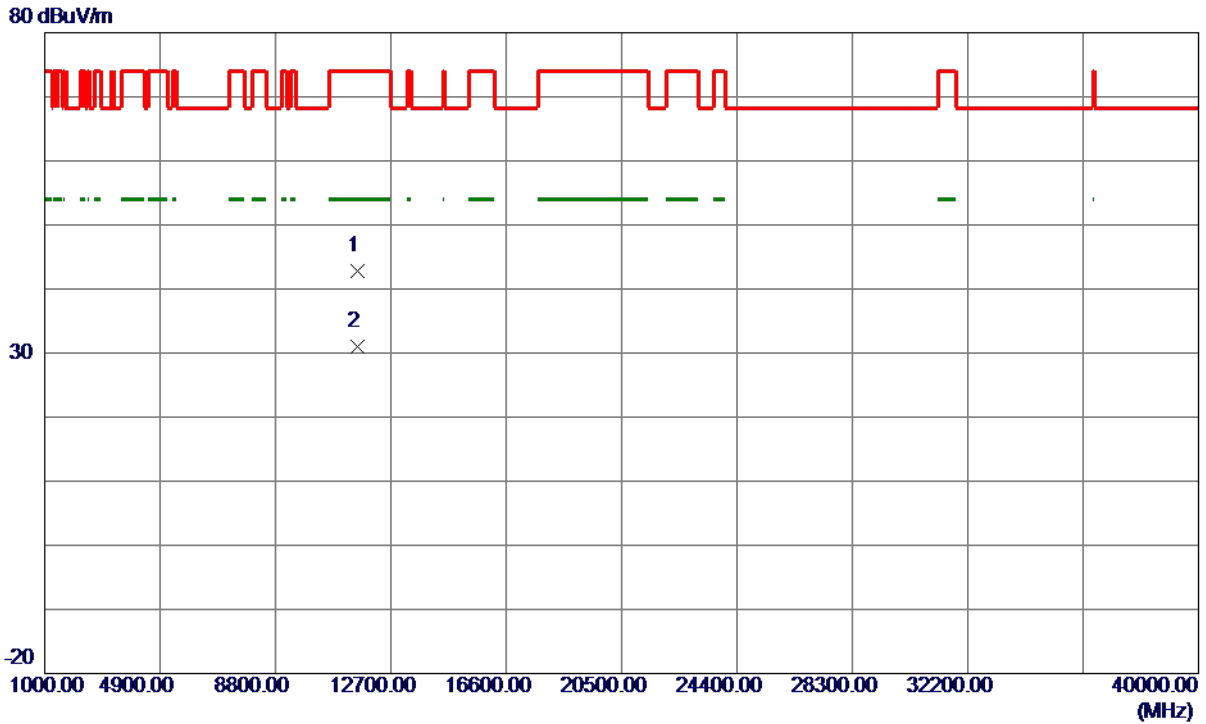

No.	Freq. MHz	Reading Level dBuV/m	Correct Factor dB	Measure ment dBuV/m	Limit dBuV/m	Margin dB	Detector	Comment
1	11555.0000	31.96	10.83	42.79	74.00	-31.21	Peak	
2 *	11569.4750	20.09	10.86	30.95	54.00	-23.05	AVG	

**REMARKS:**

- (1) Measurement Value = Reading Level + Correct Factor.
- (2) Margin Level = Measurement Value - Limit Value.

## APPENDIX E - BANDWIDTH

Test Mode	UNII-1_TX A Mode
-----------	------------------

Channel	Frequency (MHz)	26 dB Bandwidth (MHz)	99 % Emission Bandwidth (MHz)
36	5180	19.97	16.59
40	5200	19.68	16.49
48	5240	19.76	16.49

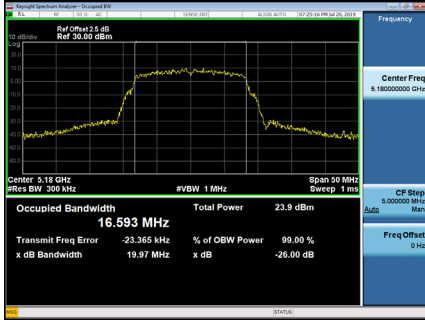
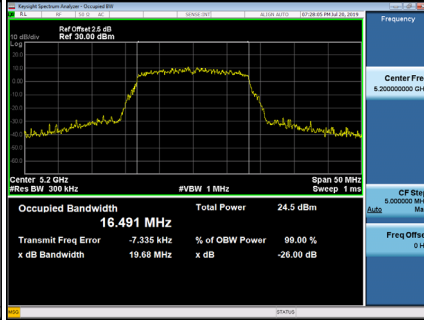
**CH36**

**CH40**

**CH48**
