

Preliminary



- **Base Station with Host Serial Interface**
- **Compatible with RFM miniMESH™ Network Protocol**
- **3 V, Very Low Current Operation**
- **Ready-to-Use OEM Module**

The DM1800-916MB is the 916.50 MHz base station module in the DM1800 family of RF transceivers. The DM1800 family is designed for adding embedded wireless connectivity to a wide range of monitoring and control systems. The DM1800-916MB is equipped with a serial I/O port to interface to a host microcontroller. The module also includes an analog input, a logic input, and a logic output for local monitoring and control. Radio communications range in an “open field” environment is typically 200 meters/hop. The DM1800-916MB combines RFM’s very low current ASH radio technology with low power microcontroller technology to achieve long battery life. This module is compatible with RFM’s miniMESH™ network protocol, which provides add-on “plug-and-play” multicast mesh network routing. The DM1800-916MB is certified for operation under FCC 15.249 regulations.

Absolute Maximum Ratings

Rating	Value	Units
All Input/Output Pins Except VIN	-0.3 to +3.3	V
Non-Operating Ambient Temperature Range	-50 to +100	°C

Electrical Characteristics

Characteristic	Sym	Notes	Minimum	Typical	Maximum	Units
Operating Frequency	f_o		916.30		916.70	MHz
Modulation Type				OOK		
RF Encoded Data Transmission Rate				4.8		kb/s
Average Receiver Input Current, No External Power Supply Load	I_R			4		mA
Receiver Input Signal for 10^{-3} BER, 25 °C				-98		dBm
Peak Transmitter Input Current, No External Power Supply Load	I_{TP}				13.5	mA
Peak Transmitter Output Power	P_O			1		mW
Analog Input Measurement Range (10-bit ADC)			0		VOUT	V
Source Impedance to Analog Input					10	K
Digital In Logic High			2.4			V
Digital In Logic Low					.45	V
Digital Out Logic High, No Load			2.4			V
Digital In Logic Low, No Load					0.3	V
Digital Output Source Current, 1K load				1.1		mA
Digital Output Sink Current, 1K load				1.2		mA
Serial Port Data Rate				9.6		kb/s
Power Supply Input Voltage Range, -40 to +85 °C	VIN		2.6		14	V
Power Supply Input Voltage Range, 0 to +85 °C	VIN		3.1		14	V
Regulated Power Supply Output Voltage, VIN 3.1 to 14 V	VOUT			3.0		Vdc
Regulated Power Supply Voltage Ripple					10	mV _{P-P}

DM1800-916MB

916.50 MHz Transceiver Module



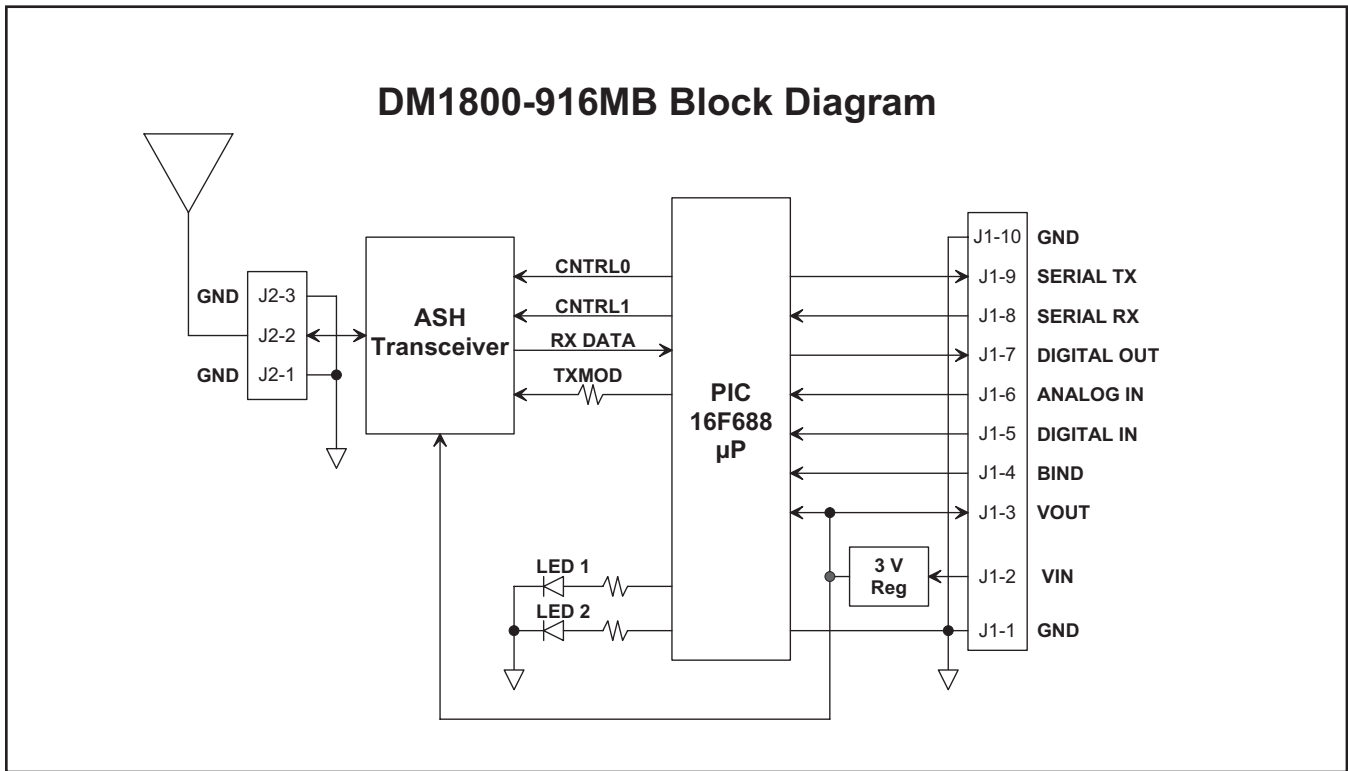

Figure 1

Theory of Operation

The major components of the DM1800-916MB include an RFM TR1000 ASH transceiver and a Microchip PIC16F688 microcontroller. The TR1000 operates on a frequency of 916.50 MHz, at a nominal output power of 1 mW.

The 16F688 provides a 9.6 kb/s serial interface for communication with a host microcontroller. A companion interface board is available with USB bridge circuitry to interface the DM1800-916MB to a host PC. Three of the 16F688 I/O pins are configured for external monitoring or control. *Digital In* is configured as a logic input with a weak pull-up for sensing a contact closure to a ground pad. *Digital Out* is configured a logic output. *Analog In* is configured as a 10-bit analog-to-digital input. The DM1800 includes two LEDs that indicate the module's operating mode.

The DM1800-916MB is compatible with RFM's miniMESH™ network protocol, which provides add-on "plug-and-play" mesh network routing to improve communication range and robustness.

DM1800-916MB FCC Certification

The DM1800-916MB hardware has been certified for operation under FCC Part 15 Rules, Section 15.249.

This certification applies only when a DM1800-916MB is equipped with one of the following RFM antennas:

- helical antenna, RFM part number 500-1195-003
- helical antenna, RFM part number 500-1195-103

WARNING: *the DM1800-916MB must be re-certified if used with any antennas other than the two listed above. Contact RFM for further information if your application requires a special antenna configuration.*

FCC Notices and Labels

This device complies with Part 15 of the FCC rules. Operation is subject to the following two conditions: (1) this device may not cause harmful interference, and (2) this device must accept any interference received, including interference that may cause undesired operation.

A clearly visible label is required on the outside of the user's (OEM) enclosure stating that this product contains a DM1800-916MB transceiver assembly, FCC ID: TE6-DM1800.

WARNING: This device operates under Part 15 of the FCC rules. Any modification to this device, not expressly authorized by RF Monolithics, Inc., may void the user's authority to operate this device.

DM1800-916MB I/O Pad Descriptions

Pin	Name	Description
J1-1	GND	This pad is a signal and power supply ground.
J1-2	VIN	This is the power supply input pad. The allowed input voltage range is 2.6 to 14 V.
J1-3	VOUT	VOUT tracks 50 to 100 mV below VIN when VIN is in the range of 2.6 to 3.1 V. When VIN is in the range of 3.1 to 14 V, VOUT is regulated at 3.0 Vdc. Up to 10 mA can be supplied from this pad for powering external circuits such as thermistor-resistor networks. External circuitry must not impress more than 10 mV _{p-p} ripple on the regulated output voltage.
J1-4	BIND	This pad is connected to a logic input on the microcontroller, and is configured with a weak pull-up. When this pin is momentarily grounded (to J1-1 or J1-10, the module is placed into the bind mode, allowing this module to be associated with other modules to form a network.
J1-5	DIGITAL IN	This pad is connected to a logic input on the microcontroller, and is configured with a weak pull-up, allowing both logic signals and contact closures referenced to J-1 or J-10 to be read. The value of this input is sent over the RF channel as a response to an RF command. The input voltage range on this pad is 0 to VOUT. Applying a voltage outside of this range may damage the module.
J1-6	ANALOG IN	This pad is the input to the microcontroller's 10-bit analog-to-digital (ADC) converter. The ADC input range is 0 to VOUT, referenced to J1-1 or J1-10. The input voltage range on this pad is 0 to VOUT. Applying a voltage outside of this range may damage the module. The ADC reading is sent over the RF channel as a response to an RF command.
J1-7	DIGITAL OUT	This pad is connected to a logic output on the microcontroller through a 1 kilohm resistor, which provides short-circuit protection. The value of this output is set or read over the RF channel as a response to an RF command.
J1-8	SERIAL RX	This pad is connected to the module's serial data input (USART). Data to this pin is received at 9.6 kb/s, using 8 data bits, no parity, and one stop bit. The input voltage range on this pad is 0 to VOUT. Applying a voltage outside of this range may damage the module.
J1-9	SERIAL TX	This pad is connected to the module's serial data output (USART) through a 1 kilohm resistor, which provides short-circuit protection. Data from this pad is sent at 9.6 kb/s, using 8 data bits, no parity, and one stop bit.
J1-10	GND	This pad is a signal and power supply ground.
J2-1	GND	This pad is a ground for the antenna port.
J2-2	ANT	This pad is the antenna port.
J2-3	GND	This pad is a ground for the antenna port.

DM1800-916MB I/O Pad Labels

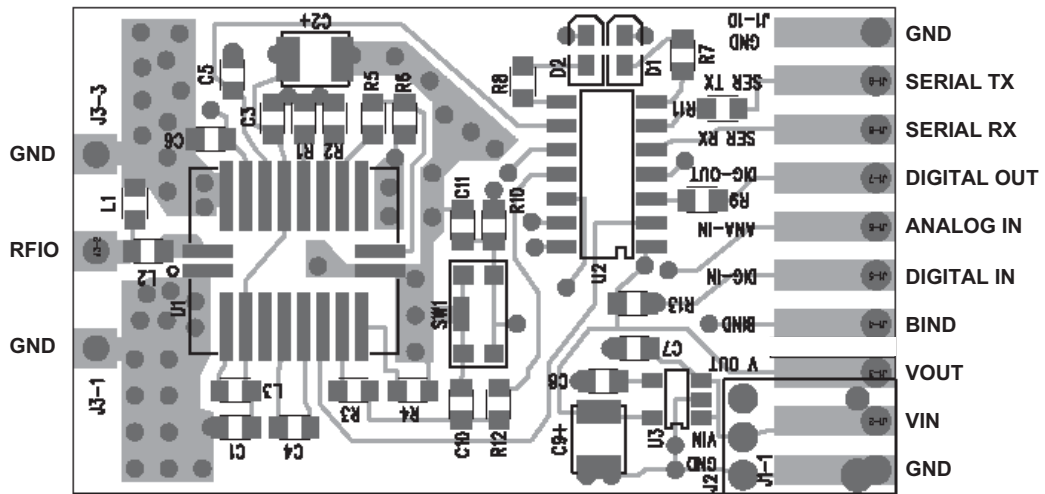
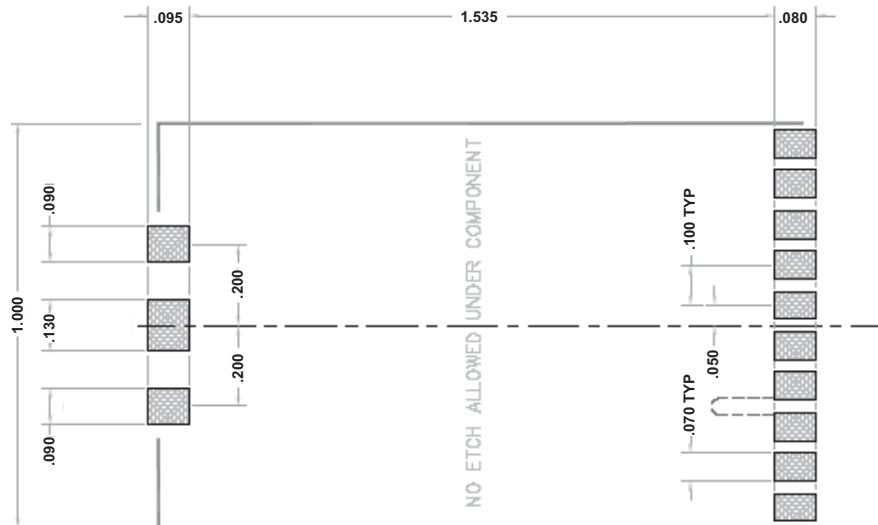

Figure 2

DM1800-916MB SMT Mounting Pattern



Dimensions in inches. PCB plus component height is .170 max;
PCB plus antenna height is 1.15 max

Figure 3

Note: Specifications subject to change without notice.

file: dm1800_916bk.vp, 2005.12.07 rev