



MET Laboratories, Inc. *Safety Certification - EMI - Telecom Environmental Simulation*

914 WEST PATAPSCO AVENUE • BALTIMORE, MARYLAND 21230-3432 • PHONE (410) 354-3300 • FAX (410) 354-3313

33439 WESTERN AVENUE • UNION CITY, CALIFORNIA 94587 • PHONE (510) 489-6300 • FAX (510) 489-6372

3162 BELICK STREET • SANTA CLARA, CA 95054 • PHONE (408) 748-3585 • FAX (510) 489-6372

13301 MCCALLEN PASS • AUSTIN, TEXAS 78753 • PHONE (512) 287-2500 • FAX (512) 287-2513

November 26, 2014

Roku
12980 Saratoga Ave.
Saratoga, CA 95070

Dear Monika Painuly,

Enclosed is the EMC Wireless test report for compliance testing of the Roku, RC2X as tested to the requirements of Title 47 of the CFR, Ch. 1 (10-1-06 ed.), Part 15, Subpart B and ICES-003, Issue 5 August 2012 for a Class B Digital Device, and FCC Part 15 Subpart C and RSS-210, Issue 8, Dec. 2010 for Intentional Radiators.

Thank you for using the services of MET Laboratories, Inc. If you have any questions regarding these results or if MET can be of further service to you, please feel free to contact me.

Sincerely yours,
MET LABORATORIES, INC.

Jennifer Warnell
Documentation Department

Reference: (\Roku\EMCS84062-FCC247 Rev. 1)

Certificates and reports shall not be reproduced except in full, without the written permission of MET Laboratories, Inc.

Electromagnetic Compatibility Criteria Test Report

for the

**Roku
RC2X**

Tested under

the FCC Certification Rules
contained in

Title 47 of the CFR, Parts 15 Subpart B & ICES-003
for Class B Digital Devices
&
15.247 Subpart C & RSS-210, Issue 8, Dec. 2010
for Intentional Radiators

MET Report: EMCS84062-FCC247 Rev. 1

November 26, 2014

Prepared For:

**Roku
12980 Saratoga Ave.
Saratoga, CA 95070**

**Prepared By:
MET Laboratories, Inc.
914 W. Patapsco Ave.
Baltimore, MD 21230**

Electromagnetic Compatibility Criteria Test Report

for the

Roku
RC2X

Tested under
the FCC Certification Rules
contained in
Title 47 of the CFR, Parts 15 Subpart B & ICES-003
for Class B Digital Devices
&
15.247 Subpart C & RSS-210, Issue 8, Dec. 2010
for Intentional Radiators



Andy Shen, Project Engineer
Electromagnetic Compatibility Lab



Jennifer Warnell
Documentation Department

Engineering Statement: The measurements shown in this report were made in accordance with the procedures indicated, and the emissions from this equipment were found to be within the limits applicable. I assume full responsibility for the accuracy and completeness of these measurements, and for the qualifications of all persons taking them. It is further stated that upon the basis of the measurements made, the equipment tested is capable of operation in accordance with the requirements of the FCC Rules Parts 15B, 15.247 and Industry Canada standards ICES-003, Issue 5 August 2012, RSS-210, Issue 8, Dec. 2010 under normal use and maintenance.



Asad Bajwa,
Director, Electromagnetic Compatibility Lab

Report Status Sheet

Revision	Report Date	Reason for Revision
∅	November 7, 2014	Initial Issue.
1	November 26, 2014	Revised to reflect engineer corrections.

Table of Contents

I.	Executive Summary	1
	A. Purpose of Test	2
	B. Executive Summary	2
II.	Equipment Configuration	3
	A. Overview.....	4
	B. References.....	5
	C. Test Site	5
	D. Description of Test Sample.....	6
	E. Equipment Configuration.....	7
	F. Support Equipment	7
	G. Ports and Cabling Information.....	7
	H. Mode of Operation.....	8
	I. Method of Monitoring EUT Operation	8
	J. Modifications	8
	a) Modifications to EUT.....	8
	b) Modifications to Test Standard.....	8
	K. Disposition of EUT	8
III.	Electromagnetic Compatibility Criteria for Unintentional Radiators	9
	§ 15.107(a) Conducted Emissions Limits.....	10
	§ 15.109(a) Radiated Emissions Limits.....	11
IV.	Electromagnetic Compatibility Criteria for Intentional Radiators	13
	§ 15.203 Antenna Requirement	14
	§ 15.207(a) Conducted Emissions Limits.....	15
	§ 15.247(a)(a) 6 dB and 99% Bandwidth	16
	§ 15.247(b) Peak Power Output	20
	§ 15.247(d) Radiated Spurious Emissions Requirements and Band Edge.....	24
	§ 15.247(d) RF Conducted Spurious Emissions Requirements and Band Edge.....	38
	§ 15.247(e) Peak Power Spectral Density	45
	§ 15.247(i) Maximum Permissible Exposure	48
V.	Test Equipment	49
VI.	Certification & User's Manual Information	51
	A. Certification Information	52
	B. Label and User's Manual Information	56
VII.	ICES-003 Procedural & Labeling Requirements.....	58

List of Tables

Table 1. Executive Summary of EMC Part 15.247 Compliance Testing	2
Table 2. EUT Summary Table.....	4
Table 3. References	5
Table 4. Equipment Configuration	7
Table 5. Support Equipment.....	7
Table 6. Ports and Cabling Information	7
Table 7. Conducted Limits for Radio Frequency Devices calculated from FCC Part 15 Subsections 15.107(a) (b)	10
Table 8. Radiated Emissions Limits calculated from FCC Part 15, § 15.109 (a) (b)	11
Table 9. Radiated Emissions Limits, Test Results, 30 MHz – 1 GHz, FCC Limits	12
Table 10. Conducted Limits for Intentional Radiators from FCC Part 15 § 15.207(a)	15
Table 11. 6 dB Occupied Bandwidth, Test Results	17
Table 12. 99% Occupied Bandwidth, Test Results	17
Table 13. Output Power Requirements from §15.247(b)	20
Table 14. Peak Power Output, Test Results	21
Table 15. Restricted Bands of Operation.....	24
Table 16. Radiated Emissions Limits Calculated from FCC Part 15, § 15.209 (a)	25
Table 17. Test Equipment List	50

List of Plots

Plot 1. Radiated Emissions, 30 MHz - 1 GHz	12
Plot 2. Occupied Bandwidth, Low Channel, 2412 MHz, 802.11b	18
Plot 3. Occupied Bandwidth, Mid Channel, 2437 MHz, 802.11b	18
Plot 4. Occupied Bandwidth, High Channel, 2462 MHz, 802.11b	18
Plot 5. Occupied Bandwidth, Low Channel, 2412 MHz, 802.11g	19
Plot 6. Occupied Bandwidth, Mid Channel, 2437 MHz, 802.11g	19
Plot 7. Occupied Bandwidth, High Channel, 2462 MHz, 802.11g	19
Plot 8. Peak Power Output, Low Channel, 2412 MHz, 802.11b	22
Plot 9. Peak Power Output, Mid Channel, 2442 MHz, 802.11b	22
Plot 10. Peak Power Output, High Channel, 2462 MHz, 802.11b	22
Plot 11. Peak Power Output, Low Channel, 2412 MHz, 802.11g	23
Plot 12. Peak Power Output, Mid Channel, 2442 MHz, 802.11g	23
Plot 13. Peak Power Output, High Channel, 2462 MHz, 802.11g	23
Plot 14. Radiated Spurious Emissions, Low Channel, 2412 MHz, 802.11b, 30 MHz – 1 GHz, Average	26
Plot 15. Radiated Spurious Emissions, Low Channel, 2412 MHz, 802.11b, 30 MHz – 1 GHz, Peak	26
Plot 16. Radiated Spurious Emissions, Low Channel, 2412 MHz, 802.11b, 1 GHz – 7 GHz, Average	26
Plot 17. Radiated Spurious Emissions, Low Channel, 2412 MHz, 802.11b, 7 GHz – 18 GHz, Average	27
Plot 18. Radiated Spurious Emissions, Mid Channel, 2442 MHz, 802.11b, 30 MHz – 1 GHz, Average	27
Plot 19. Radiated Spurious Emissions, Mid Channel, 2442 MHz, 802.11b, 30 MHz – 1 GHz, Peak	27
Plot 20. Radiated Spurious Emissions, Mid Channel, 2442 MHz, 802.11b, 1 GHz – 7 GHz, Average	28
Plot 21. Radiated Spurious Emissions, Mid Channel, 2442 MHz, 802.11b, 7 GHz – 18 GHz, Average	28
Plot 22. Radiated Spurious Emissions, High Channel, 2462 MHz, 802.11b, 30 MHz – 1 GHz, Average	28
Plot 23. Radiated Spurious Emissions, High Channel, 2462 MHz, 802.11b, 30 MHz – 1 GHz, Peak	29
Plot 24. Radiated Spurious Emissions, High Channel, 2462 MHz, 802.11b, 1 GHz – 7 GHz, Average	29
Plot 25. Radiated Spurious Emissions, High Channel, 2462 MHz, 802.11b, 7 GHz – 18 GHz, Average	29
Plot 26. Radiated Spurious Emissions, Low Channel, 2412 MHz, 802.11g, 30 MHz – 1 GHz, Average	30
Plot 27. Radiated Spurious Emissions, Low Channel, 2412 MHz, 802.11g, 30 MHz – 1 GHz, Peak	30
Plot 28. Radiated Spurious Emissions, Low Channel, 2412 MHz, 802.11g, 1 GHz – 7 GHz, Average	30
Plot 29. Radiated Spurious Emissions, Low Channel, 2412 MHz, 802.11g, 7 GHz – 18 GHz, Average	31
Plot 30. Radiated Spurious Emissions, Mid Channel, 2442 MHz, 802.11g, 30 MHz – 1 GHz, Average	31

Plot 31. Radiated Spurious Emissions, Mid Channel, 2442 MHz, 802.11g, 30 MHz – 1 GHz, Peak	31
Plot 32. Radiated Spurious Emissions, Mid Channel, 2442 MHz, 802.11g, 1 GHz – 7 GHz, Average	32
Plot 33. Radiated Spurious Emissions, Mid Channel, 2442 MHz, 802.11g, 7 GHz – 18 GHz, Average	32
Plot 34. Radiated Spurious Emissions, High Channel, 2462 MHz, 802.11g, 30 MHz – 1 GHz, Average	32
Plot 35. Radiated Spurious Emissions, High Channel, 2462 MHz, 802.11g, 30 MHz – 1 GHz, Peak	33
Plot 36. Radiated Spurious Emissions, High Channel, 2462 MHz, 802.11g, 1 GHz – 7 GHz, Average	33
Plot 37. Radiated Spurious Emissions, High Channel, 2462 MHz, 802.11g, 7 GHz – 18 GHz, Average	33
Plot 38. Radiated Band Edge, 802.11b, Channel 1, Average	34
Plot 39. Radiated Band Edge, 802.11b, Channel 1, Peak	34
Plot 40. Radiated Band Edge, 802.11b, Channel 11, Average	35
Plot 41. Radiated Band Edge, 802.11b, Channel 11, Peak	35
Plot 42. Radiated Band Edge, 802.11g, Channel 1, Average	36
Plot 43. Radiated Band Edge, 802.11g, Channel 1, Peak	36
Plot 44. Radiated Band Edge, 802.11g, Channel 11, Average	37
Plot 45. Radiated Band Edge, 802.11g, Channel 11, Peak	37
Plot 46. Conducted Spurious Emissions, Low Channel, 2412 MHz, 802.11b, 30 MHz – 1 GHz	39
Plot 47. Conducted Spurious Emissions, Low Channel, 2412 MHz, 802.11b, 1 GHz – 18 GHz	39
Plot 48. Conducted Spurious Emissions, Mid Channel, 2442 MHz, 802.11b, 30 MHz – 1 GHz	39
Plot 49. Conducted Spurious Emissions, Mid Channel, 2442 MHz, 802.11b, 1 GHz – 18 GHz	40
Plot 50. Conducted Spurious Emissions, High Channel, 2462 MHz, 802.11b, 30 MHz – 1 GHz	40
Plot 51. Conducted Spurious Emissions, High Channel, 2462 MHz, 802.11b, 1 GHz – 18 GHz	40
Plot 52. Conducted Spurious Emissions, Low Channel, 2412 MHz, 802.11g, 30 MHz – 1 GHz	41
Plot 53. Conducted Spurious Emissions, Low Channel, 2412 MHz, 802.11g, 1 GHz – 18 GHz	41
Plot 54. Conducted Spurious Emissions, Mid Channel, 2442 MHz, 802.11g, 30 MHz – 1 GHz	41
Plot 55. Conducted Spurious Emissions, Mid Channel, 2442 MHz, 802.11g, 1 GHz – 18 GHz	42
Plot 56. Conducted Spurious Emissions, High Channel, 2462 MHz, 802.11g, 30 MHz – 1 GHz	42
Plot 57. Conducted Spurious Emissions, High Channel, 2462 MHz, 802.11g, 1 GHz – 18 GHz	42
Plot 58. Conducted Band Edge, Low Channel, 2412 MHz, 802.11b	43
Plot 59. Conducted Band Edge, High Channel, 2462 MHz, 802.11b	43
Plot 60. Conducted Band Edge, Low Channel, 2412 MHz, 802.11g	44
Plot 61. Conducted Band Edge, High Channel, 2462 MHz, 802.11g	44
Plot 62. Peak Power Spectral Density, Low Channel, 2412 MHz, 802.11b	46
Plot 63. Peak Power Spectral Density, Mid Channel, 2442 MHz, 802.11b	46
Plot 64. Peak Power Spectral Density, High Channel, 2462 MHz, 802.11b	46
Plot 65. Peak Power Spectral Density, Low Channel, 2412 MHz, 802.11g	47
Plot 66. Peak Power Spectral Density, Mid Channel, 2442 MHz, 802.11g	47
Plot 67. Peak Power Spectral Density, High Channel, 2462 MHz, 802.11g	47

List of Figures

Figure 1. Block Diagram of Test Configuration	6
Figure 2. Block Diagram, Occupied Bandwidth Test Setup	16
Figure 3. Peak Power Output Test Setup	20
Figure 4. Block Diagram, Conducted Spurious Emissions Test Setup	38
Figure 5. Block Diagram, Peak Power Spectral Density Test Setup	45

List of Terms and Abbreviations

AC	Alternating Current
ACF	Antenna Correction Factor
Cal	Calibration
<i>d</i>	Measurement Distance
dB	Decibels
dB μ A	Decibels above one microamp
dB μ V	Decibels above one microvolt
dB μ A/m	Decibels above one microamp per meter
dB μ V/m	Decibels above one microvolt per meter
DC	Direct Current
E	Electric Field
DSL	Digital Subscriber Line
ESD	Electrostatic Discharge
EUT	Equipment Under Test
<i>f</i>	Frequency
FCC	Federal Communications Commission
GRP	Ground Reference Plane
H	Magnetic Field
HCP	Horizontal Coupling Plane
Hz	Hertz
IEC	International Electrotechnical Commission
kHz	kilohertz
kPa	kilopascal
kV	kilovolt
LISN	Line Impedance Stabilization Network
MHz	Megahertz
μ H	microhenry
μ	microfarad
μ s	microseconds
NEBS	Network Equipment-Building System
PRF	Pulse Repetition Frequency
RF	Radio Frequency
RMS	Root-Mean-Square
TWT	Traveling Wave Tube
V/m	Volts per meter
VCP	Vertical Coupling Plane

I. Executive Summary

A. Purpose of Test

An EMC evaluation was performed to determine compliance of the Roku RC2X, with the requirements of Part 15, §15.247. All references are to the most current version of Title 47 of the Code of Federal Regulations in effect. In accordance with §2.1033, the following data is presented in support of the Certification of the RC2X. Roku should retain a copy of this document which should be kept on file for at least two years after the manufacturing of the RC2X, has been **permanently** discontinued.

B. Executive Summary

The following tests were conducted on a sample of the equipment for the purpose of demonstrating compliance with Part 15, §15.247, in accordance with Roku, purchase order number 325443. All tests were conducted using measurement procedure ANSI C63.4-2003.

FCC Reference 47 CFR Part 15.247:2005	IC Reference RSS-210 Issue 8: 2010; RSS-GEN Issue 3: 2010	Description	Compliance
47 CFR Part 15.107 (a)	ICES-003 Issue 5 August 2012	Conducted Emission Limits for a Class B Digital Device	Not Applicable
47 CFR Part 15.109 (a)	ICES-003 Issue 5 August 2012	Radiated Emission Limits for a Class B Digital Device	Compliant
Title 47 of the CFR, Part 15 §15.203	N/A	Antenna Requirement	Compliant
Title 47 of the CFR, Part 15 §15.207(a)	RSS-GEN (7.2.4)	Conducted Emission Limits	Not Applicable
Title 47 of the CFR, Part 15 §15.247(a)(2)	RSS-Gen(4.6)	6dB Occupied Bandwidth	Compliant
		99% Occupied Bandwidth	Compliant
Title 47 of the CFR, Part 15 §15.247(b)	RSS-210(A8.4)	Peak Power Output	Compliant
Title 47 of the CFR, Part 15 §15.247(d); §15.209; §15.205	RSS-210(A8.5)	Radiated Spurious Emissions Requirements	Compliant
Title 47 of the CFR, Part 15 §15.247(d)	RSS-210(A8.5)	RF Conducted Spurious Emissions Requirements	Compliant
Title 47 of the CFR, Part 15 §15.247(d)	RSS-210(A8.5)	RF Conducted Band Edge	Compliant
Title 47 of the CFR, Part 15; §15.247(e)	RSS-210(A8.2)	Peak Power Spectral Density	Compliant
Title 47 of the CFR, Part 15 §15.247(i)	RSS-Gen(5.6)	Maximum Permissible Exposure (MPE)	Compliant

Table 1. Executive Summary of EMC Part 15.247 Compliance Testing

II. Equipment Configuration

A. Overview

MET Laboratories, Inc. was contracted by Roku to perform testing on the RC2X, under Roku's purchase order number 325443.

This document describes the test setups, test methods, required test equipment, and the test limit criteria used to perform compliance testing of the Roku, RC2X.

The results obtained relate only to the item(s) tested.

Model(s) Tested:	RC2X	
Model(s) Covered:	RC2X	
EUT Specifications:	Primary Power: 3 VDC	
	FCC ID: TC2-RCB4	
	Type of Modulations:	OFDM
	Equipment Code:	DTS
	Peak RF Output Power:	7.17 dBm
	EUT Frequency Ranges:	2412-2462 MHz
Analysis:	The results obtained relate only to the item(s) tested.	
Environmental Test Conditions:	Temperature: 15-35° C	
	Relative Humidity: 30-60%	
	Barometric Pressure: 860-1060 mbar	
Evaluated by:	Andy Shen	
Report Date(s):	November 26, 2014	

Table 2. EUT Summary Table

B. References

CFR 47, Part 15, Subpart C	Federal Communication Commission, Code of Federal Regulations, Title 47, Part 15: General Rules and Regulations, Allocation, Assignment, and Use of Radio Frequencies
CFR 47, Part 15, Subpart B	Electromagnetic Compatibility: Criteria for Radio Frequency Devices
RSS-210, Issue 8, Dec. 2010	Low-power Licence-exempt Radiocommunications Devices (All Frequency Bands): Category I Equipment
RSS-GEN, Issue 3, Dec. 2010	General Requirements and Information for the Certification of Radio Apparatus
ICES-003, Issue 5 August 2012	Information Technology Equipment (ITE) — Limits and methods of measurement
ANSI C63.4:2003	Methods and Measurements of Radio-Noise Emissions from Low-Voltage Electrical And Electronic Equipment in the Range of 9 kHz to 40 GHz
ISO/IEC 17025:2005	General Requirements for the Competence of Testing and Calibration Laboratories
ANSI C63.10-2009	American National Standard for Testing Unlicensed Wireless Devices

Table 3. References

C. Test Site

All testing was performed at MET Laboratories, Inc., 3162 Belick St., Santa Clara, CA 95054. All equipment used in making physical determinations is accurate and bears recent traceability to the National Institute of Standards and Technology.

Radiated Emissions measurements were performed in a 10 meter semi-anechoic chamber (equivalent to an Open Area Test Site). In accordance with §2.948(a)(3), a complete site description is contained at MET Laboratories.

D. Description of Test Sample

The Roku RC2X, Equipment Under Test (EUT), is a Remote Control. It will work with Roku Streaming Stick. It supports Wi-Fi 802.11b/g/ Channel 1 through 11. The remote shall operate from 2 x AAA Alkaline batteries. Power requirements shall be a maximum operating voltage of 3.3 Volts. The power will not be regulated.

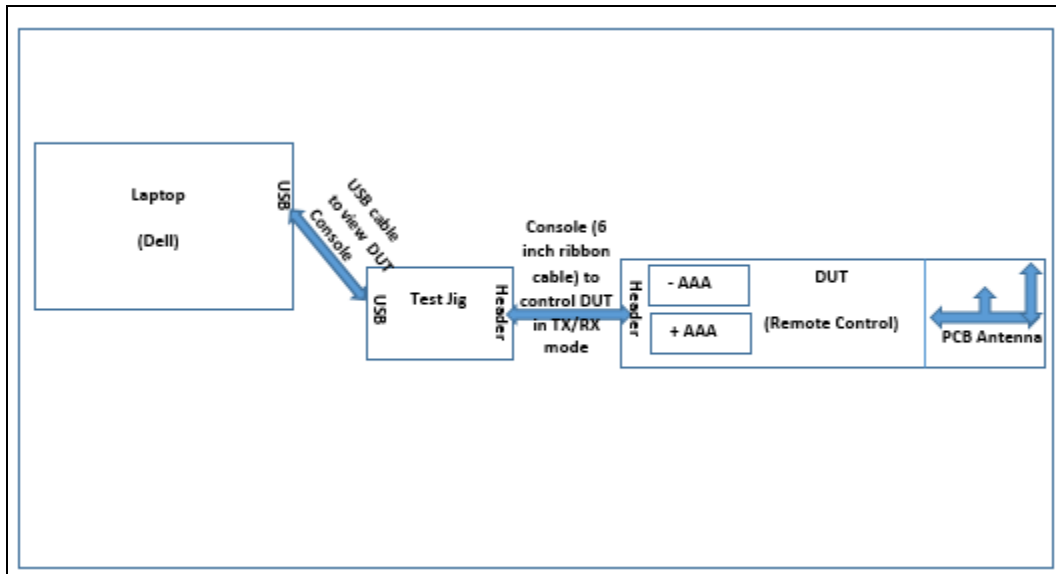

Figure 1. Block Diagram of Test Configuration

E. Equipment Configuration

The EUT was set up as outlined in Figure 1, Block Diagram of Test Setup. All cards, racks, etc., incorporated as part of the EUT is included in the following list.

Ref. ID	Name / Description	Model Number	Part Number	Serial Number	Revision
1	N/A	Roku Wi-Fi Remote Control	RC2X	3226000088	N/A
2	N/A	Roku Wi-Fi Remote Control	RC2X	3226000090	14092531

Table 4. Equipment Configuration

F. Support Equipment

Support equipment necessary for the operation and testing of the EUT is included in the following list.

Ref. ID	Name / Description	Manufacturer	Model Number
1	Test Jig	Atmel	210920-10
2	Dell Lap top	Dell	Latitude E6410
3	Ribbon Cable	Atmel	N/A

Table 5. Support Equipment

G. Ports and Cabling Information

Ref. ID	Port Name on EUT	Cable Description	Qty.	Length (m)	Shielded (Y/N)	Termination Point
1	Micro USB-to-USB	Computer Cable	1	1	No	N/A
2	Lap top Charger	Dell AC Adapter	1	1	No	(AC 100 -240 V/50 – 60 Hz)

Table 6. Ports and Cabling Information

H. Mode of Operation

FW is running on the DUT (Remote Control) and through console we can configure DUT into different Wi-Fi channels.

I. Method of Monitoring EUT Operation

LED is blinking when first Battery is inserted and Remote is in the pairing mode. Once it pairs up with Roku RSS LED will turn ON and turn off when goes into sleep mode.

J. Modifications

a) Modifications to EUT

No modifications were made to the EUT.

b) Modifications to Test Standard

No modifications were made to the test standard.

K. Disposition of EUT

The test sample including all support equipment submitted to the Electro-Magnetic Compatibility Lab for testing was returned to Roku upon completion of testing.

III. Electromagnetic Compatibility Criteria for Unintentional Radiators

Electromagnetic Compatibility Criteria

§ 15.107 Conducted Emissions Limits

Test Requirement(s): **15.107 (a)** Except for Class A digital devices, for equipment that is designed to be connected to the public utility (AC) power line, the radio frequency voltage that is conducted back onto the AC power line on any frequency or frequencies within the band 150 kHz to 30 MHz shall not exceed the limits in Table 7. Compliance with this provision shall be based on the measurement of the radio frequency voltage between each power line and ground at the power terminals.

15.107 (b) For a Class A digital device that is designed to be connected to the public utility (AC) power line, the radio frequency voltage that is conducted back onto the AC power line on any frequency or frequencies within the band 150 kHz to 30 MHz shall not exceed the limits in Table 7. Compliance with this provision shall be based on the measurement of the radio frequency voltage between each power line and ground at the power terminals. The lower limit applies at the band edges.

Frequency range (MHz)	Class A Conducted Limits (dB μ V)		*Class B Conducted Limits (dB μ V)	
	Quasi-Peak	Average	Quasi-Peak	Average
* 0.15 - 0.45	79	66	66 - 56	56 - 46
0.45 - 0.5	79	66	56	46
0.5 - 30	73	60	60	50

Note 1 — The lower limit shall apply at the transition frequencies.
Note 2 — The limit decreases linearly with the logarithm if the frequency in the range 0.15 MHz to 0.5 MHz.

Table 7. Conducted Limits for Radio Frequency Devices calculated from FCC Part 15 Subsections 15.107(a) (b)

Test Results: The EUT was not applicable with the Class B requirement(s) of this section.

Radiated Emission Limits

§ 15.109 Radiated Emissions Limits

Test Requirement(s): **15.109 (a)** Except for Class A digital devices, the field strength of radiated emissions from unintentional radiators at a distance of 3 meters shall not exceed the Class B limits expressed in Table 8.

15.109 (b) The field strength of radiated emissions from a Class A digital device, as determined at a distance of 10 meters, shall not exceed the Class A limits expressed in Table 8.

Frequency (MHz)	Field Strength (dB μ V/m)	
	§15.109 (b), Class A Limit (dB μ V) @ 10m	§15.109 (a), Class B Limit (dB μ V) @ 3m
30 - 88	39.00	40.00
88 - 216	43.50	43.50
216 - 960	46.40	46.00
Above 960	49.50	54.00

Table 8. Radiated Emissions Limits calculated from FCC Part 15, §15.109 (a) (b)

Test Procedures: The EUT was placed on a non-metallic table, 80 cm above the ground plane inside a semi-anechoic chamber. The method of testing and test conditions of ANSI C63.4 were used. An antenna was located 10m from the EUT on an adjustable mast. A pre-scan was first performed in order to find prominent radiated emissions. For final emissions measurements at each frequency of interest, the EUT was rotated and the antenna height was varied between 1 m and 4 m in order to maximize the emission. Measurements in both horizontal and vertical polarities were made and the data was recorded. Unless otherwise specified, measurements were made using a quasi-peak detector with a 120 kHz bandwidth.

Test Results: The EUT was compliant with the Class B requirement(s) of this section. Measured emissions were below applicable limits.

Test Engineer(s): Andy Shen

Test Date(s): 11/03/14

Radiated Emissions Limits Test Results, Class B

Frequency (MHz)	Antenna Polarity	EUT Azimuth (Degrees)	Antenna Height (cm)	Uncorrected Amplitude (dBμV)	ACF (dB/m)	Pre Amp Gain (dB)	CBL (dB)	DCF (dB)	Corrected Amplitude (dBμV/m)	Limit (dBμV/m)	Margin (dB)
943.7	V	94	150.76	0.43	21.257	0	5.606	0	27.293	46	-18.707
913.2	V	0	100	0.22	20.577	0	5.534	0	26.331	46	-19.669
343.32	V	197	100	6.72	14.083	0	3.338	0	24.141	46	-21.859
423.48	H	0	131.58	1.49	16.349	0	3.697	0	21.536	46	-24.464
876.04	H	0	100	0.2	20.729	0	5.427	0	26.356	46	-19.644
670.28	H	274	183.11	-1.15	18.84	0	4.779	0	22.469	46	-23.531

Table 9. Radiated Emissions Limits, Test Results, 30 MHz – 1 GHz, FCC Limits

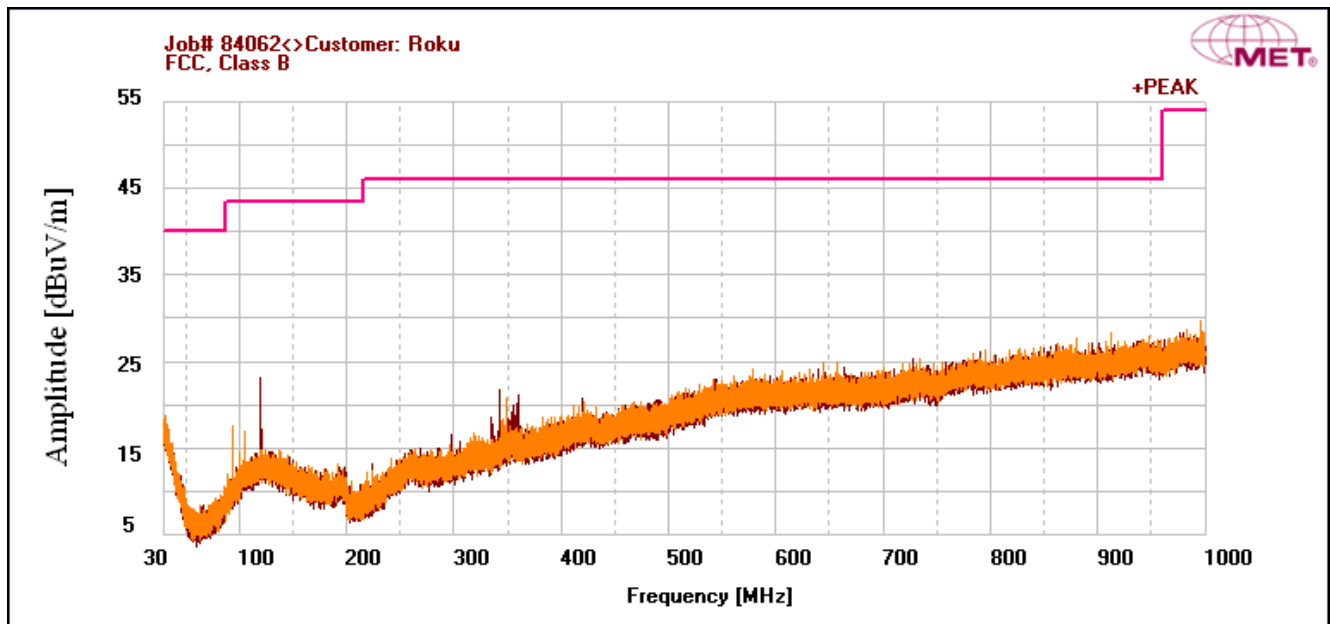

Plot 1. Radiated Emissions, 30 MHz - 1 GHz

IV. Electromagnetic Compatibility Criteria for Intentional Radiators

Electromagnetic Compatibility Criteria for Intentional Radiators

§ 15.203 Antenna Requirement

Test Requirement: § 15.203: An intentional radiator shall be designed to ensure that no antenna other than that furnished by the responsible party shall be used with the device. The use of a permanently attached antenna or of an antenna that uses a unique coupling to the intentional radiator shall be considered sufficient to comply with the provisions of this section. The manufacturer may design the unit so that a broken antenna can be replaced by the user, but the use of a standard antenna jack or electrical connector is prohibited.

The structure and application of the EUT were analyzed to determine compliance with Section 15.203 of the Rules. Section 15.203 states that the subject device must meet at least one of the following criteria:

- a.) Antenna must be permanently attached to the unit.
- b.) Antenna must use a unique type of connector to attach to the EUT.
- c.) Unit must be professionally installed. Installer shall be responsible for verifying that the correct antenna is employed with the unit.

Results: The EUT as tested is compliant the criteria of §15.203. The EUT has integral antenna.

Test Engineer(s): Andy Shen

Test Date(s): 10/27/14

Electromagnetic Compatibility Criteria for Intentional Radiators

§ 15.207(a) Conducted Emissions Limits

Test Requirement(s): § 15.207 (a): For an intentional radiator that is designed to be connected to the public utility (AC) power line, the radio frequency voltage that is conducted back onto the AC power line on any frequency or frequencies, within the band 150 kHz to 30MHz, shall not exceed the limits in the following table, as measured using a 50 μ H/50 Σ line impedance stabilization network (LISN). Compliance with the provisions of this paragraph shall be based on the measurement of the radio frequency voltage between each power line and ground at the power terminal. The lower limit applies at the boundary between the frequency ranges.

Frequency range (MHz)	§ 15.207(a), Conducted Limit (dB μ V)	
	Quasi-Peak	Average
* 0.15- 0.45	66 - 56	56 - 46
0.45 - 0.5	56	46
0.5 - 30	60	50

Table 10. Conducted Limits for Intentional Radiators from FCC Part 15 § 15.207(a)

Test Results: The EUT was not applicable with this requirement.

Electromagnetic Compatibility Criteria for Intentional Radiators

§ 15.247(a)(2) 6 dB and 99% Bandwidth

Test Requirements: § 15.247(a)(2): Operation under the provisions of this section is limited to frequency hopping and digitally modulated intentional radiators that comply with the following provisions:

For systems using digital modulation techniques, the EUT may operate in the 902-928 MHz, 2400-2483.5 MHz and 5725-5850 MHz bands. The minimum 6dB bandwidth shall be at least 500 kHz.

Test Procedure: The transmitter was on and transmitting at the highest output power. The bandwidth of the fundamental frequency was measured with the spectrum analyzer using a RBW approximately 1% of the total emission bandwidth, VBW > RBW. The 6 dB Bandwidth was measured and recorded. The measurements were performed on the low, mid and high channels.

Test Results The EUT was compliant with § 15.247 (a)(2).

The 6 dB and 99% Bandwidth was determined from the plots on the following pages.

Test Engineer(s): Andy Shen

Test Date(s): 10/28/14

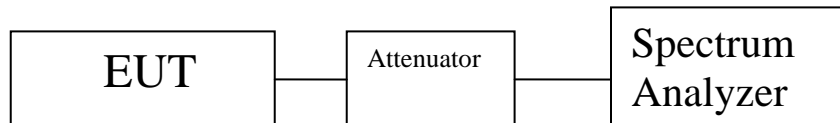

Figure 2. Block Diagram, Occupied Bandwidth Test Setup

Occupied Bandwidth Test Results

Occupied Bandwidth			
	Carrier Channel	Frequency (MHz)	Measured 6 dB Bandwidth (MHz)
802.11b	Low	2412	10.449
	Mid	2437	15.802
	High	2462	10.406
802.11g	Low	2412	15.902
	Mid	2437	15.218
	High	2462	16.063

Table 11. 6 dB Occupied Bandwidth, Test Results

Occupied Bandwidth			
	Carrier Channel	Frequency (MHz)	Measured 99% Bandwidth (MHz)
802.11b	Low	2412	12.1550
	Mid	2437	16.8994
	High	2462	12.0874
802.11g	Low	2412	17.0519
	Mid	2437	16.9035
	High	2462	16.7950

Table 12. 99% Occupied Bandwidth, Test Results

Occupied Bandwidth Test Results, 802.11b

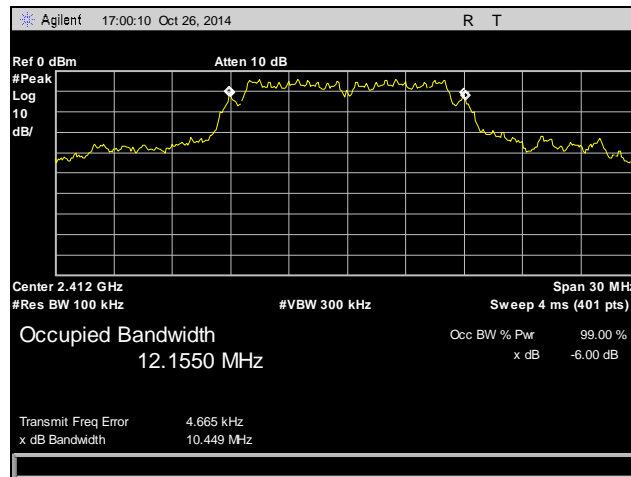

Plot 2. Occupied Bandwidth, Low Channel, 2412 MHz, 802.11b

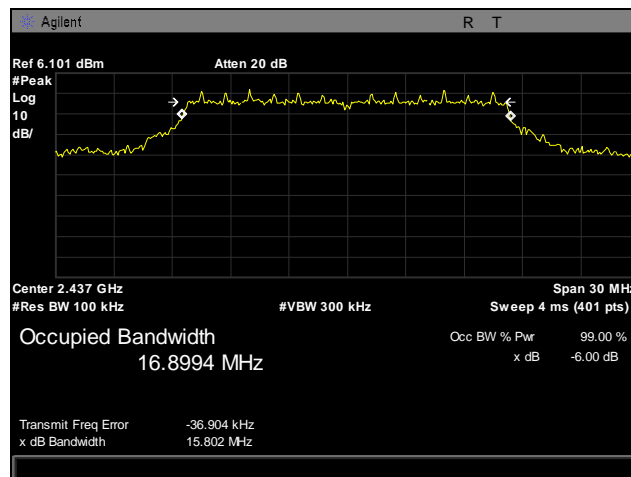

Plot 3. Occupied Bandwidth, Mid Channel, 2437 MHz, 802.11b

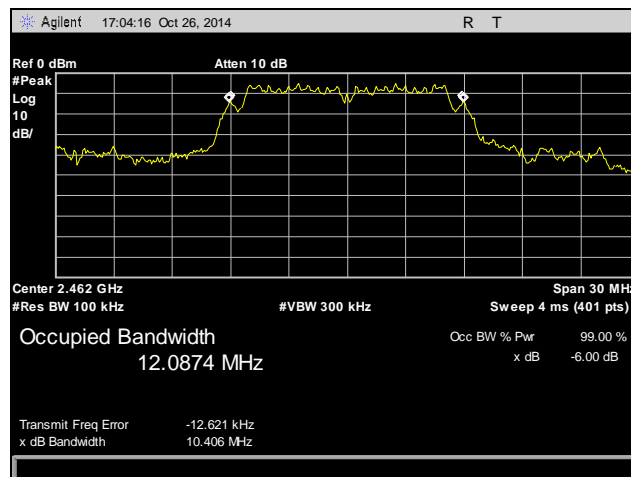

Plot 4. Occupied Bandwidth, High Channel, 2462 MHz, 802.11b

Occupied Bandwidth Test Results, 802.11g

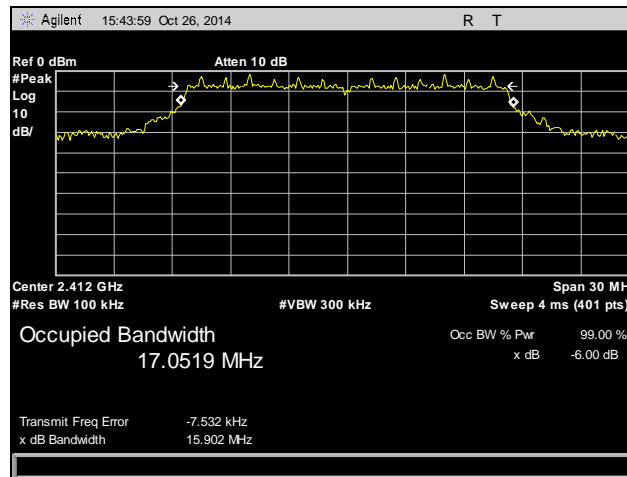

Plot 5. Occupied Bandwidth, Low Channel, 2412 MHz, 802.11g

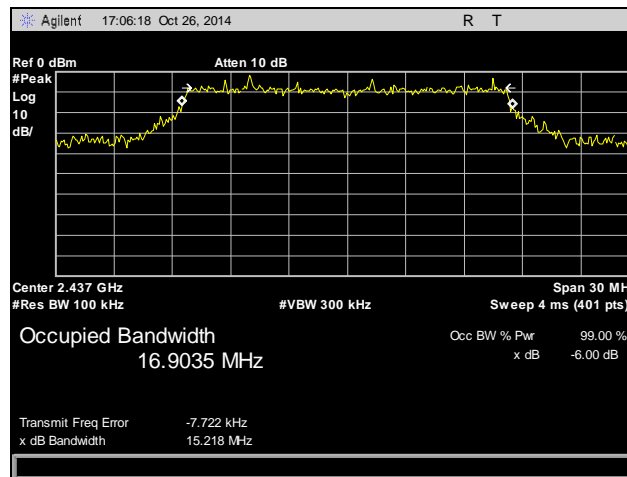

Plot 6. Occupied Bandwidth, Mid Channel, 2437 MHz, 802.11g

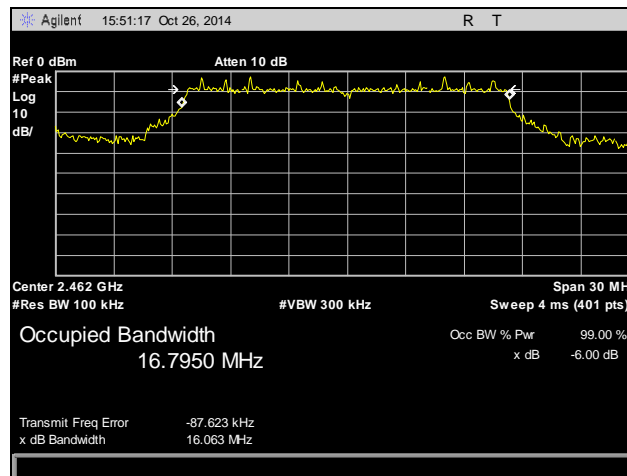

Plot 7. Occupied Bandwidth, High Channel, 2462 MHz, 802.11g

Electromagnetic Compatibility Criteria for Intentional Radiators

§ 15.247(b) Peak Power Output

Test Requirements: §15.247(b): The maximum peak output power of the intentional radiator shall not exceed the following:

Digital Transmission Systems (MHz)	Output Limit (Watts)
902-928	1.000
2400-2483.5	1.000
5725- 5850	1.000

Table 13. Output Power Requirements from §15.247(b)

§15.247(b)(4): The conducted output power limit specified in paragraph (b) of this section is based on the use of antennas with directional gains that do not exceed 6 dBi. Except as shown in paragraph (c) of this section, if transmitting antennas of directional gain greater than 6 dBi are used, the conducted output power from the intentional radiator shall be reduced below the stated values in paragraphs (b)(1), (b)(2), and (b)(3) of this section, as appropriate, by the amount in dB that the directional gain of the antenna exceeds 6 dBi.

Test Procedure: The transmitter was connected to a calibrated spectrum analyzer. The EUT was measured at the low, mid and high channels of each band at the maximum power level.

Test Results: The EUT was compliant with the Peak Power Output limits of §15.247(b).

Test Engineer(s): Andy Shen

Test Date(s): 10/28/14

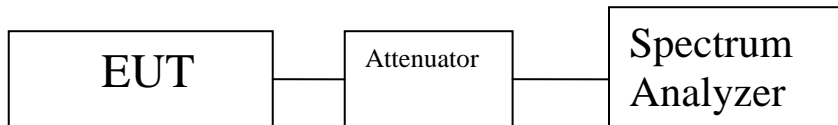

Figure 3. Peak Power Output Test Setup

Peak Power Output Test Results

Frequency (MHz)	Mode	Power (dBm)	Antenna Gain (dBi)	Limit (dBm)	Margin (dB)
2412	802.11b	7.17	0.00	30.00	-22.83
2437	802.11b	6.66	0.00	30.00	-23.34
2462	802.11b	6.74	0.00	30.00	-23.26
Frequency (MHz)	Mode	Power (dBm)	Antenna Gain (dBi)	Limit (dBm)	Margin (dB)
2412	802.11g	6.12	0.00	30	-23.88
2437	802.11g	5.76	0.00	30	-24.24
2462	802.11g	5.46	0.00	30	-24.54

Table 14. Peak Power Output, Test Results

Peak Power Output Test Results, 802.11b

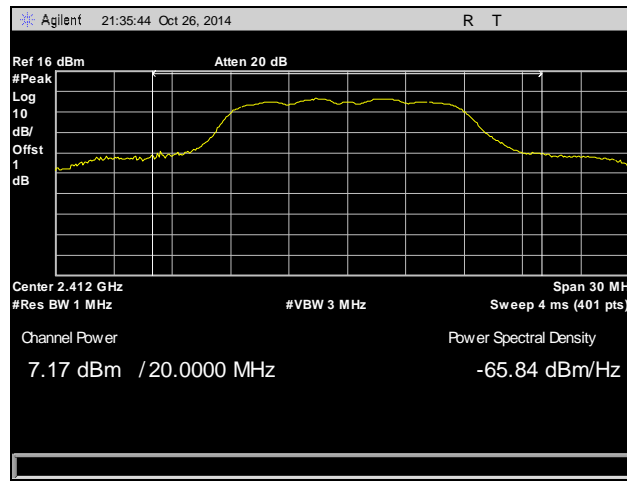

Plot 8. Peak Power Output, Low Channel, 2412 MHz, 802.11b

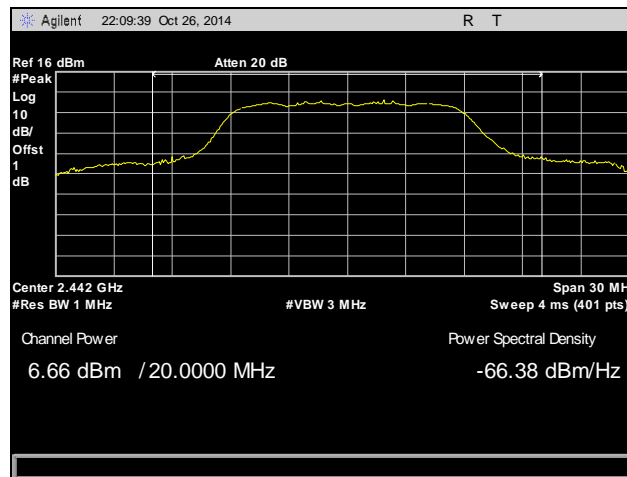

Plot 9. Peak Power Output, Mid Channel, 2442 MHz, 802.11b

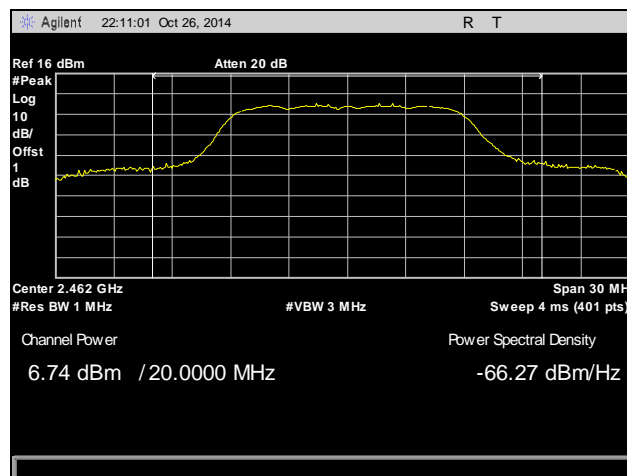

Plot 10. Peak Power Output, High Channel, 2462 MHz, 802.11b

Peak Power Output Test Results, 802.11g

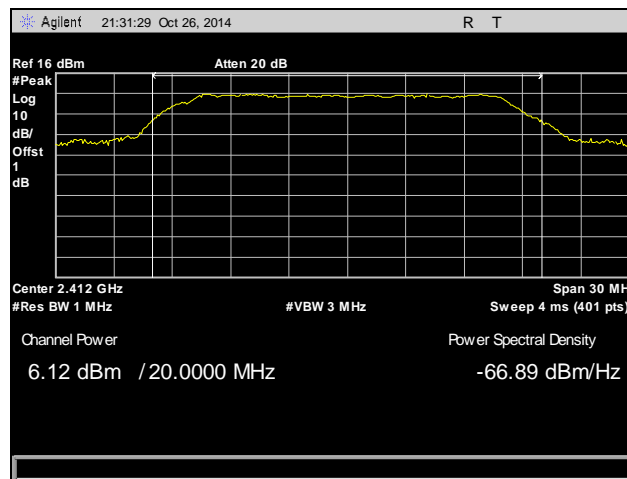

Plot 11. Peak Power Output, Low Channel, 2412 MHz, 802.11g

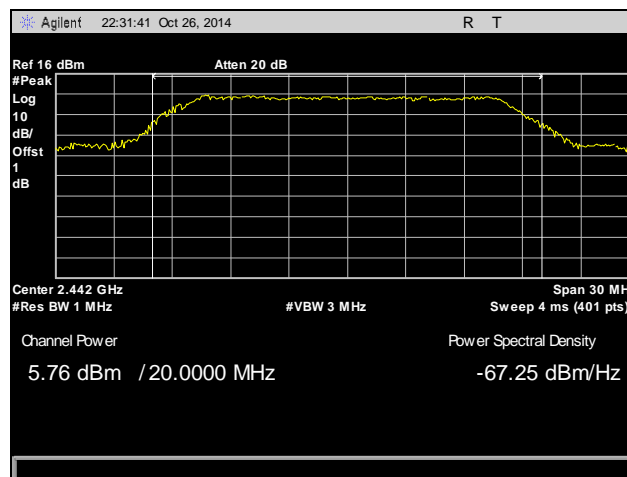

Plot 12. Peak Power Output, Mid Channel, 2442 MHz, 802.11g

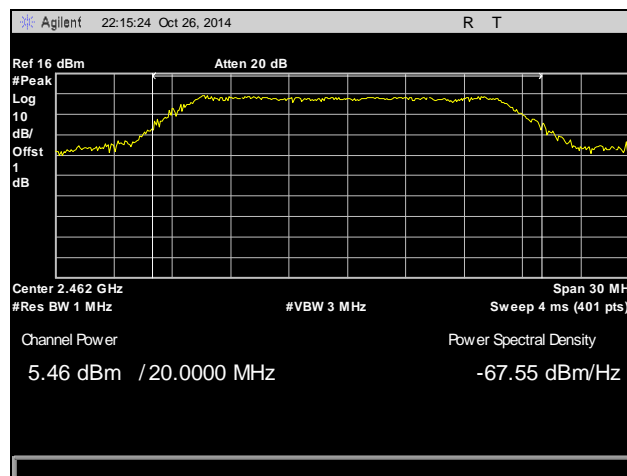

Plot 13. Peak Power Output, High Channel, 2462 MHz, 802.11g

Electromagnetic Compatibility Criteria for Intentional Radiators

§ 15.247(d) Radiated Spurious Emissions Requirements and Band Edge

Test Requirements: §15.247(d); §15.205: Emissions outside the frequency band.

§15.247(d): In any 100 kHz bandwidth outside the frequency band in which the spread spectrum or digitally modulated intentional radiator is operating, the radio frequency power that is produced by the intentional radiator shall be at least 20 dB below that in the 100 kHz bandwidth within the band that contains the highest level of the desired power, based on either an RF conducted or a radiated measurement. Attenuation below the general limits specified in § 15.209(a) is not required. In addition, radiated emissions which fall in the restricted bands, as defined in § 15.205(a), must also comply with the radiated emission limits specified in § 15.209(a).

§15.205(a): Except as shown in paragraph (d) of this section, only spurious emissions are permitted in any of the frequency bands listed below:

MHz	MHz	MHz	GHz
0.090–0.110-----	16.42–16.423	399.9–410	4.5–5.15
¹ 0.495–0.505-----	16.69475–16.69525	608–614	5.35–5.46
2.1735–2.1905-----	16.80425–16.80475	960–1240	7.25–7.75
4.125–4.128-----	25.5–25.67	1300–1427	8.025–8.5
4.17725–4.17775-----	37.5–38.25	1435–1626.5	9.0–9.2
4.20725–4.20775-----	73–74.6	1645.5–1646.5	9.3–9.5
6.215–6.218-----	74.8–75.2	1660–1710	10.6–12.7
6.26775–6.26825-----	108–121.94	1718.8–1722.2	13.25–13.4
6.31175–6.31225-----	123–138	2200–2300	14.47–14.5
8.291–8.294-----	149.9–150.05	2310–2390	15.35–16.2
8.362–8.366-----	156.52475–156.52525	2483.5–2500	17.7–21.4
8.37625–8.38675-----	156.7–156.9	2655–2900	22.01–23.12
8.41425–8.41475-----	162.0125–167.17	3260–3267	23.6–24.0
12.29–12.293-----	167.72–173.2	3332–3339	31.2–31.8
12.51975–12.52025-----	240–285	3345.8–3358 36.	43–36.5
12.57675–12.57725-----	322–335.4	3600–4400	(²)

Table 15. Restricted Bands of Operation

¹ Until February 1, 1999, this restricted band shall be 0.490 – 0.510 MHz.

² Above 38.6

Test Requirement(s): § 15.209 (a): Except as provided elsewhere in this subpart, the emissions from an intentional radiator shall not exceed the field strength levels specified in Table 16.

Frequency (MHz)	§ 15.209(a), Radiated Emission Limits (dB μ V) @ 3m
30 - 88	40.00
88 - 216	43.50
216 - 960	46.00
Above 960	54.00

Table 16. Radiated Emissions Limits Calculated from FCC Part 15, § 15.209 (a)

Test Procedures: The transmitter was turned on. Measurements were performed of the low, mid and high Channels. The EUT was rotated orthogonally through all three axes. Plots shown are corrected for both antenna correction factor and distance and compared to a 3 m limit line. A 2.4GHz notch filter was used to notch out the transmitting frequency. Only noise floor was measured above 18 GHz.

Test Results: The EUT was compliant with the Radiated Spurious Emission limits of § 15.247(d).

Test Engineer(s): Andy Shen

Test Date(s): 10/30/14

Radiated Spurious Emissions Test Results, 802.11b

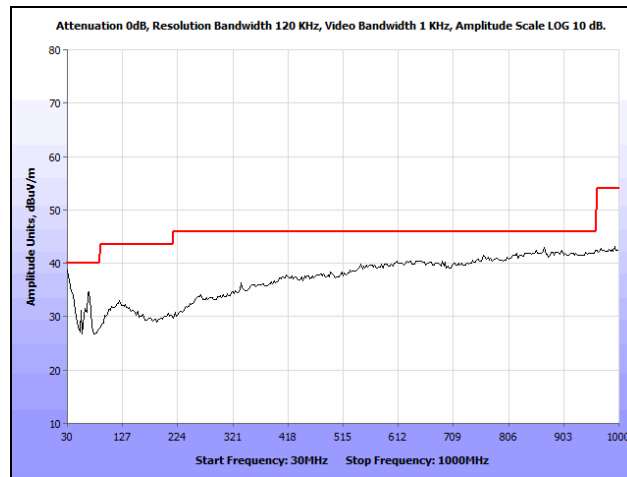

Plot 14. Radiated Spurious Emissions, Low Channel, 2412 MHz, 802.11b, 30 MHz – 1 GHz, Average

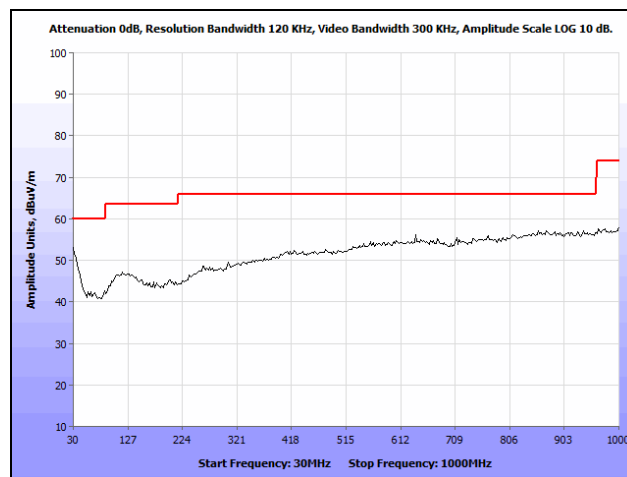

Plot 15. Radiated Spurious Emissions, Low Channel, 2412 MHz, 802.11b, 30 MHz – 1 GHz, Peak

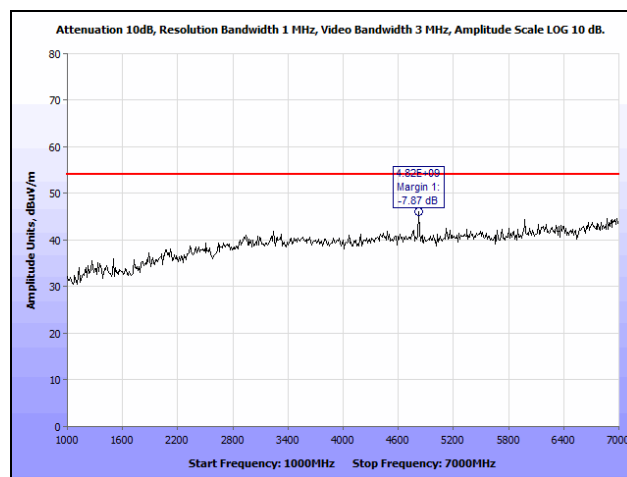

Plot 16. Radiated Spurious Emissions, Low Channel, 2412 MHz, 802.11b, 1 GHz – 7 GHz, Average

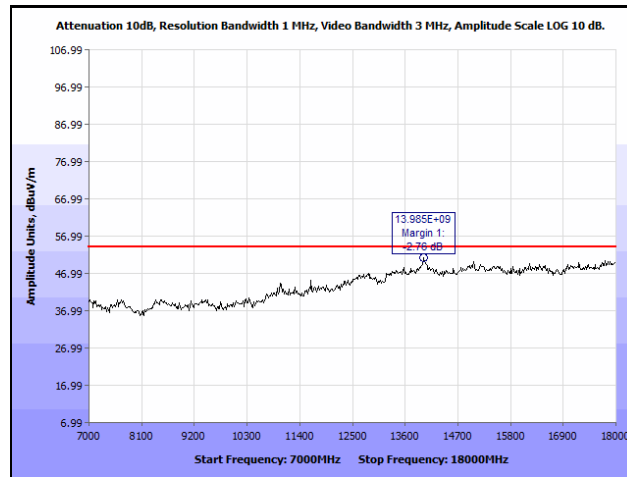

Plot 17. Radiated Spurious Emissions, Low Channel, 2412 MHz, 802.11b, 7 GHz – 18 GHz, Average

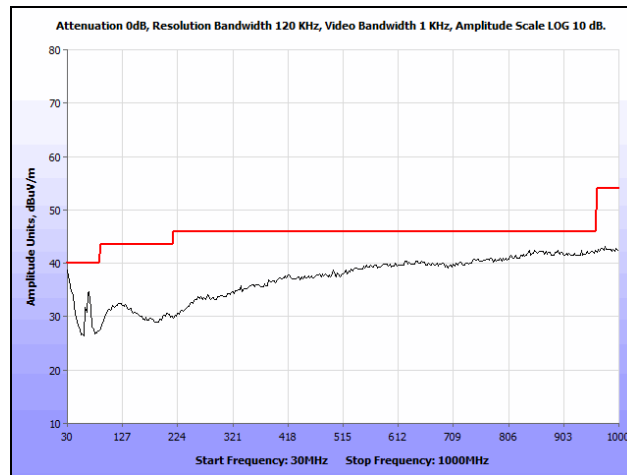

Plot 18. Radiated Spurious Emissions, Mid Channel, 2442 MHz, 802.11b, 30 MHz – 1 GHz, Average

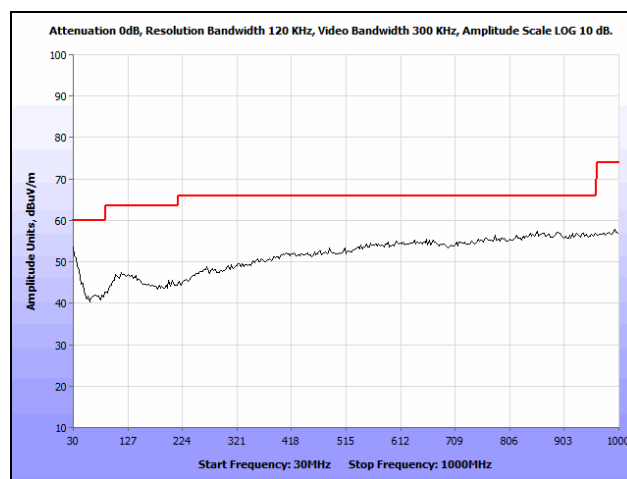

Plot 19. Radiated Spurious Emissions, Mid Channel, 2442 MHz, 802.11b, 30 MHz – 1 GHz, Peak

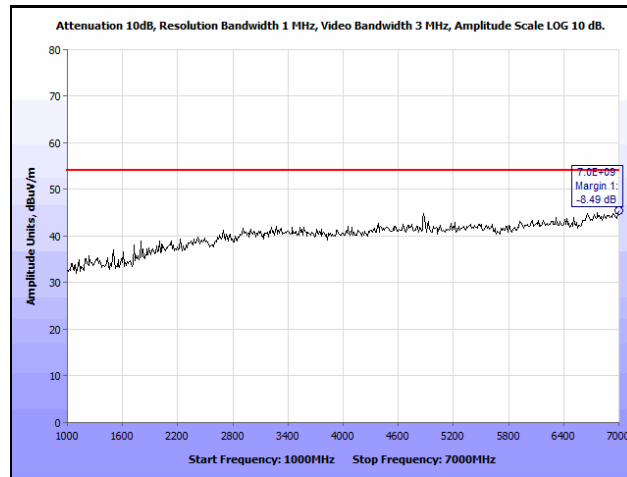

Plot 20. Radiated Spurious Emissions, Mid Channel, 2442 MHz, 802.11b, 1 GHz – 7 GHz, Average

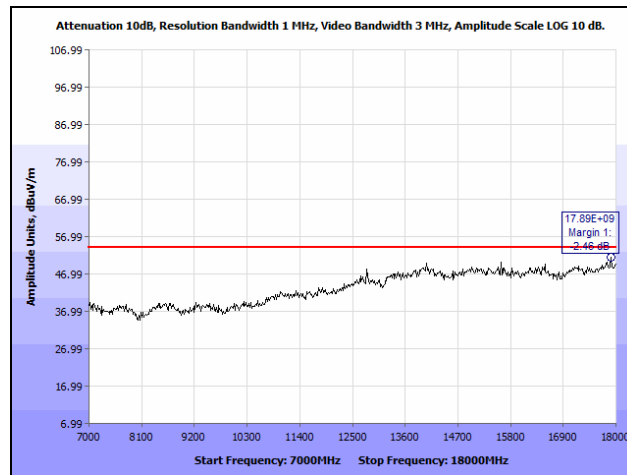

Plot 21. Radiated Spurious Emissions, Mid Channel, 2442 MHz, 802.11b, 7 GHz – 18 GHz, Average

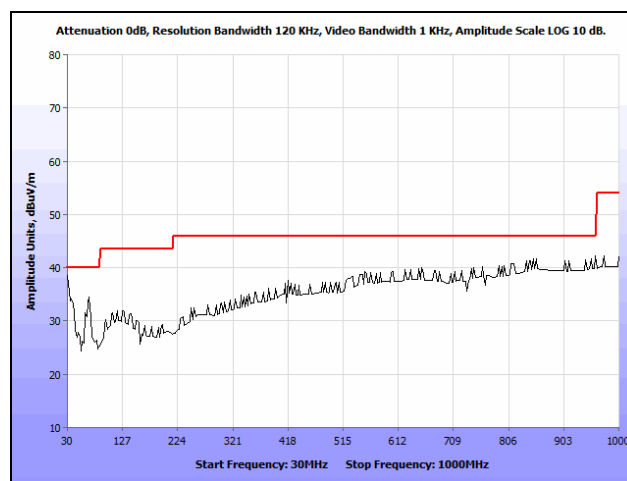

Plot 22. Radiated Spurious Emissions, High Channel, 2462 MHz, 802.11b, 30 MHz – 1 GHz, Average

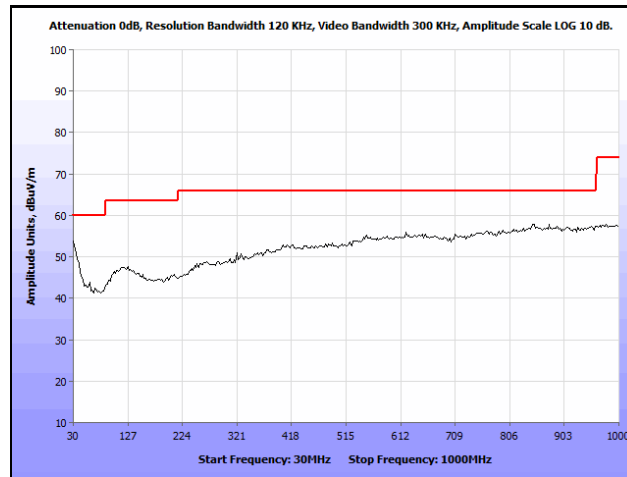

Plot 23. Radiated Spurious Emissions, High Channel, 2462 MHz, 802.11b, 30 MHz – 1 GHz, Peak

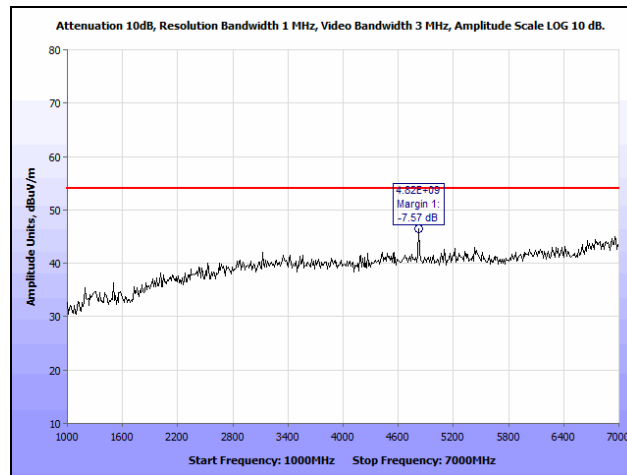

Plot 24. Radiated Spurious Emissions, High Channel, 2462 MHz, 802.11b, 1 GHz – 7 GHz, Average

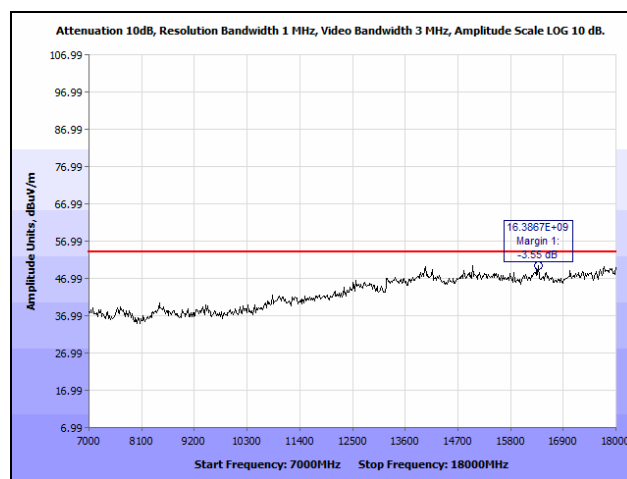

Plot 25. Radiated Spurious Emissions, High Channel, 2462 MHz, 802.11b, 7 GHz – 18 GHz, Average

Radiated Spurious Emissions Test Results, 802.11g

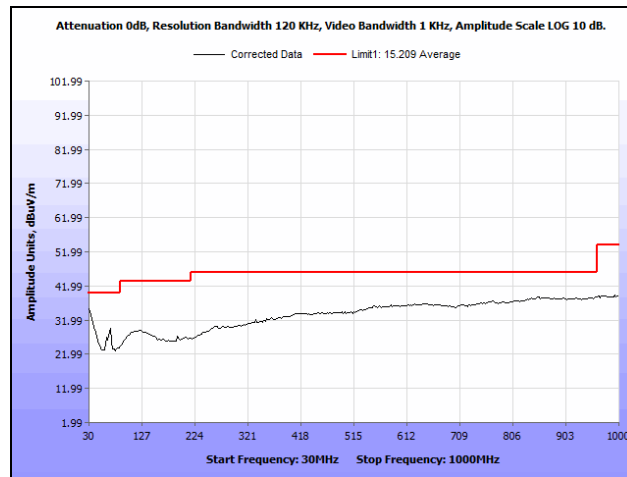

Plot 26. Radiated Spurious Emissions, Low Channel, 2412 MHz, 802.11g, 30 MHz – 1 GHz, Average

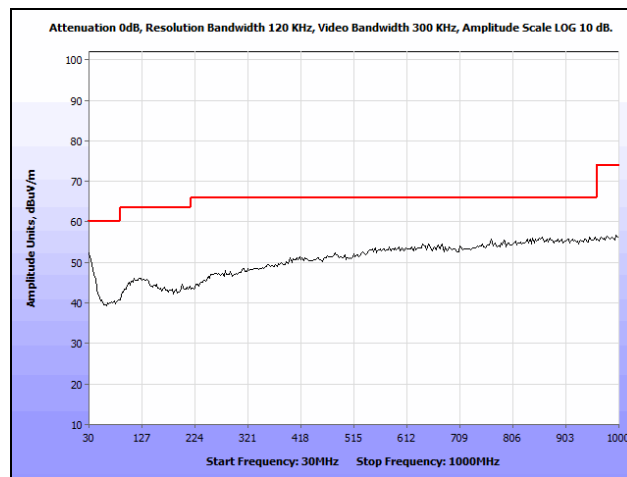

Plot 27. Radiated Spurious Emissions, Low Channel, 2412 MHz, 802.11g, 30 MHz – 1 GHz, Peak

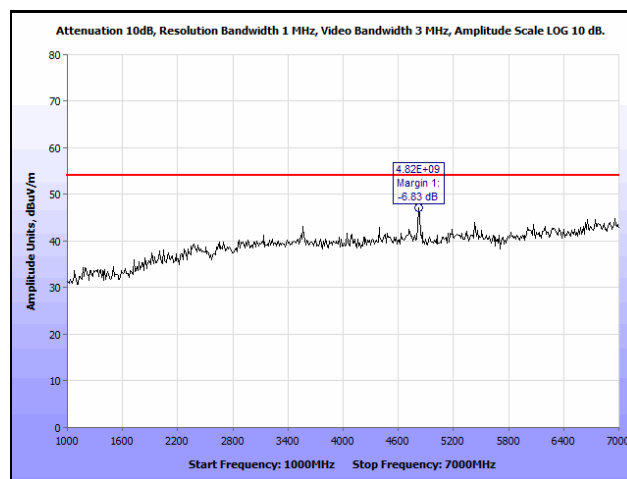

Plot 28. Radiated Spurious Emissions, Low Channel, 2412 MHz, 802.11g, 1 GHz – 7 GHz, Average

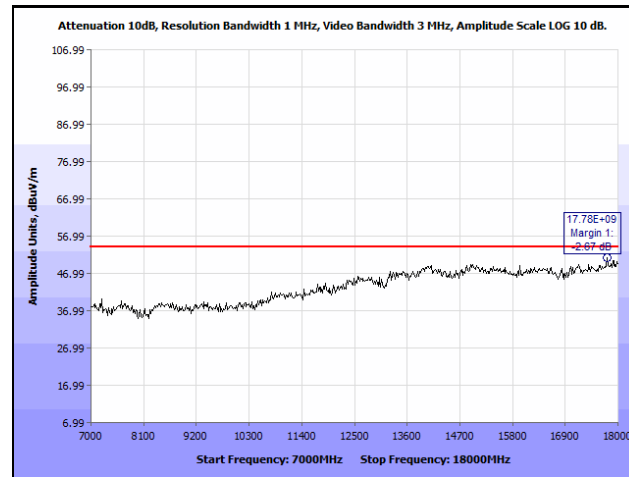

Plot 29. Radiated Spurious Emissions, Low Channel, 2412 MHz, 802.11g, 7 GHz – 18 GHz, Average

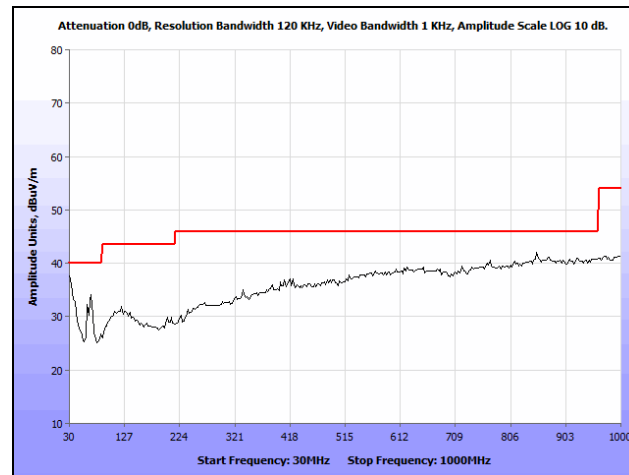

Plot 30. Radiated Spurious Emissions, Mid Channel, 2442 MHz, 802.11g, 30 MHz – 1 GHz, Average

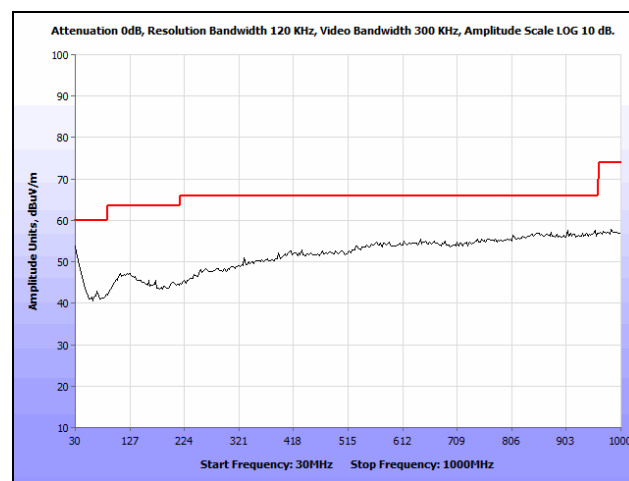

Plot 31. Radiated Spurious Emissions, Mid Channel, 2442 MHz, 802.11g, 30 MHz – 1 GHz, Peak

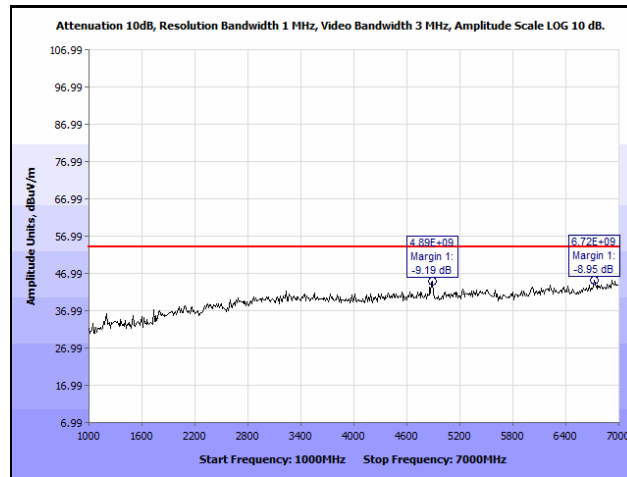

Plot 32. Radiated Spurious Emissions, Mid Channel, 2442 MHz, 802.11g, 1 GHz – 7 GHz, Average

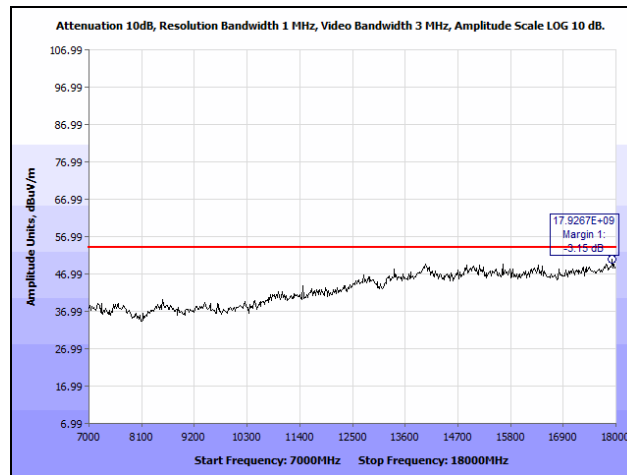

Plot 33. Radiated Spurious Emissions, Mid Channel, 2442 MHz, 802.11g, 7 GHz – 18 GHz, Average

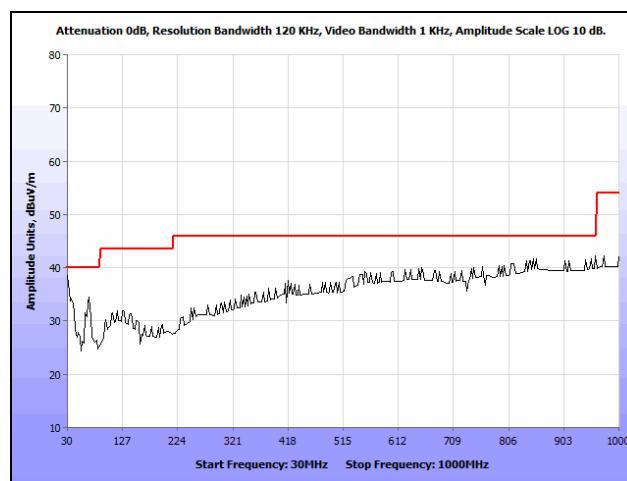

Plot 34. Radiated Spurious Emissions, High Channel, 2462 MHz, 802.11g, 30 MHz – 1 GHz, Average

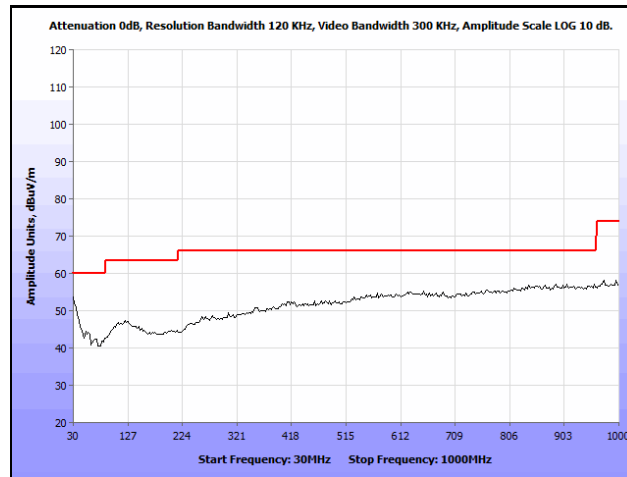

Plot 35. Radiated Spurious Emissions, High Channel, 2462 MHz, 802.11g, 30 MHz – 1 GHz, Peak

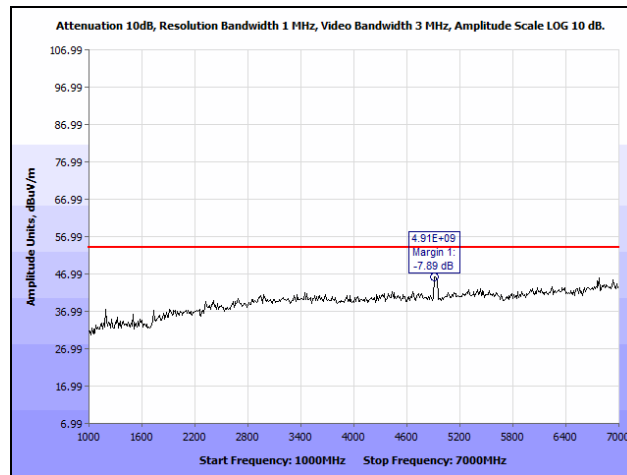

Plot 36. Radiated Spurious Emissions, High Channel, 2462 MHz, 802.11g, 1 GHz – 7 GHz, Average

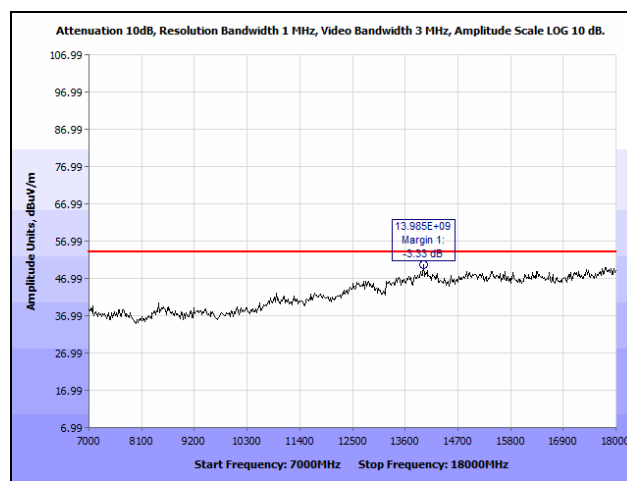

Plot 37. Radiated Spurious Emissions, High Channel, 2462 MHz, 802.11g, 7 GHz – 18 GHz, Average

Radiated Band Edge Measurements

Test Procedures: The transmitter was turned on. Measurements were performed of the low, mid and high Channels. The EUT was rotated orthogonally through all three axes. Plots shown are corrected for both antenna correction factor and distance and compared to a 3 m limit line.

Radiated Band Edge Measurements, 802.11b

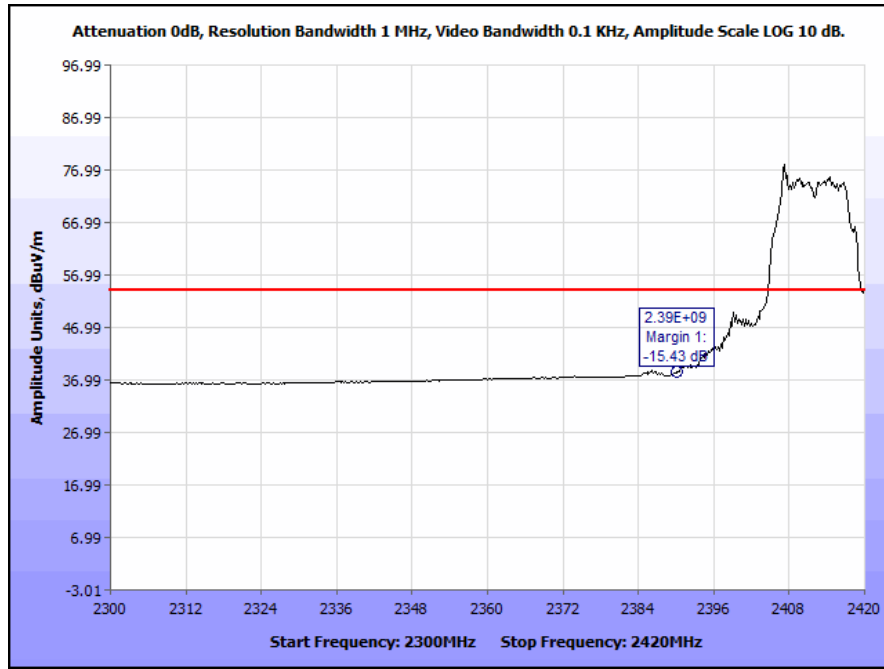

Plot 38. Radiated Band Edge, 802.11b, Channel 1, Average

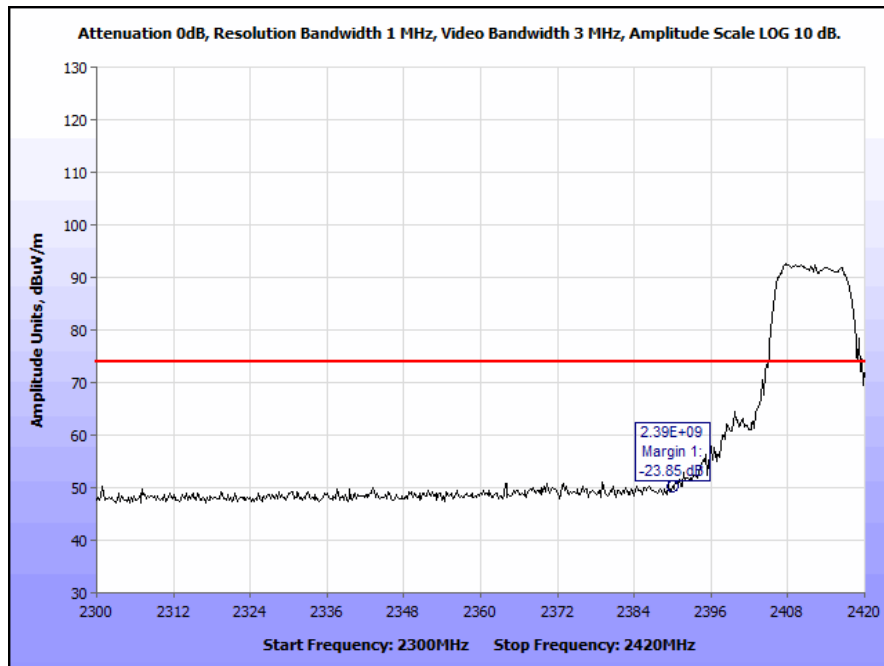

Plot 39. Radiated Band Edge, 802.11b, Channel 1, Peak

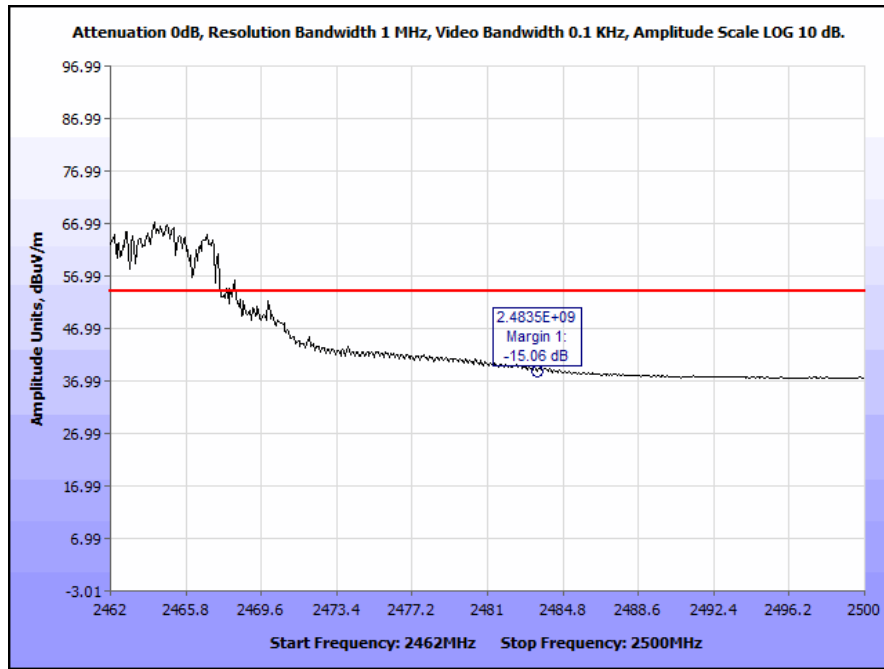

Plot 40. Radiated Band Edge, 802.11b, Channel 11, Average

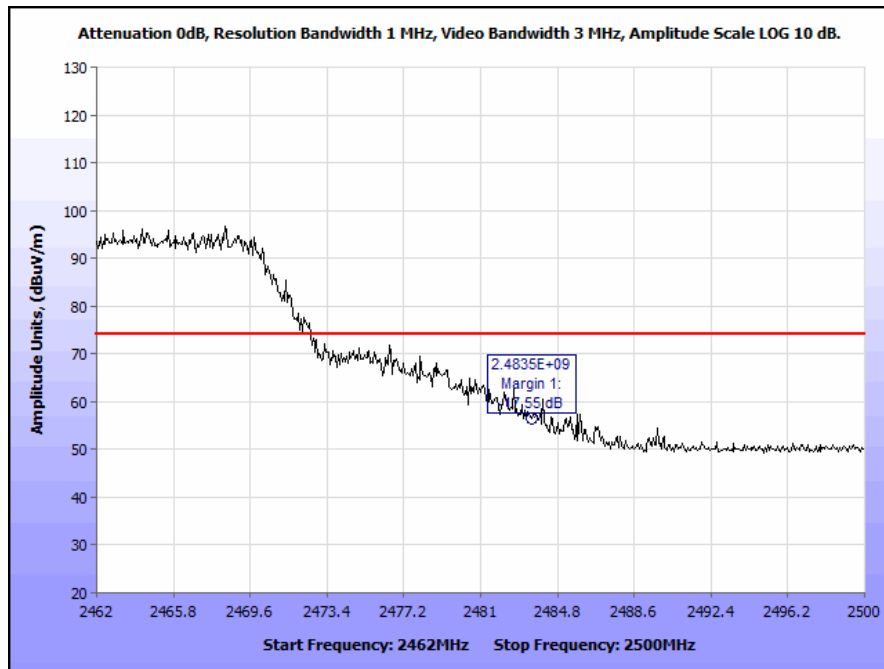

Plot 41. Radiated Band Edge, 802.11b, Channel 11, Peak

Radiated Band Edge Measurements, 802.11g

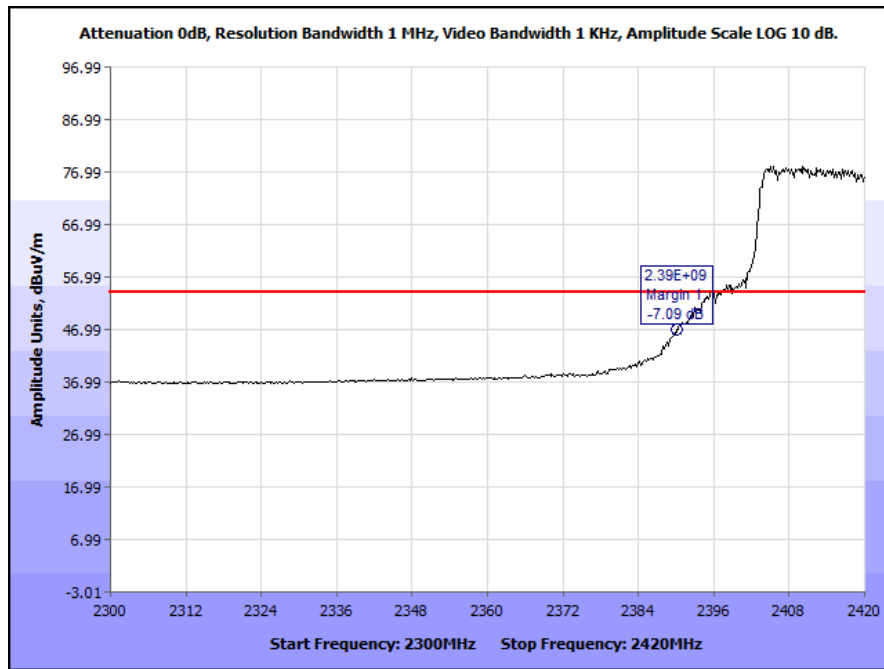

Plot 42. Radiated Band Edge, 802.11g, Channel 1, Average

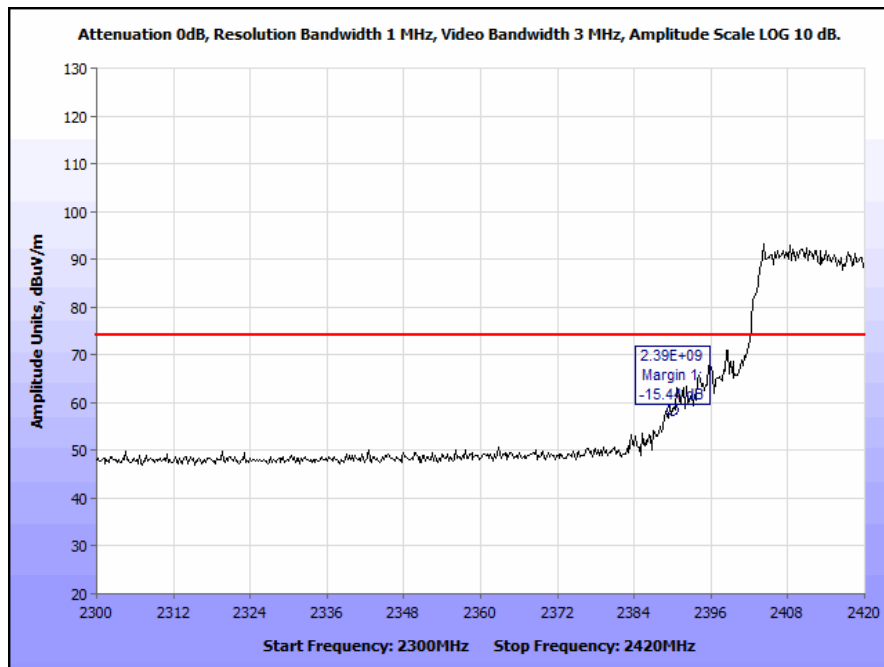

Plot 43. Radiated Band Edge, 802.11g, Channel 1, Peak

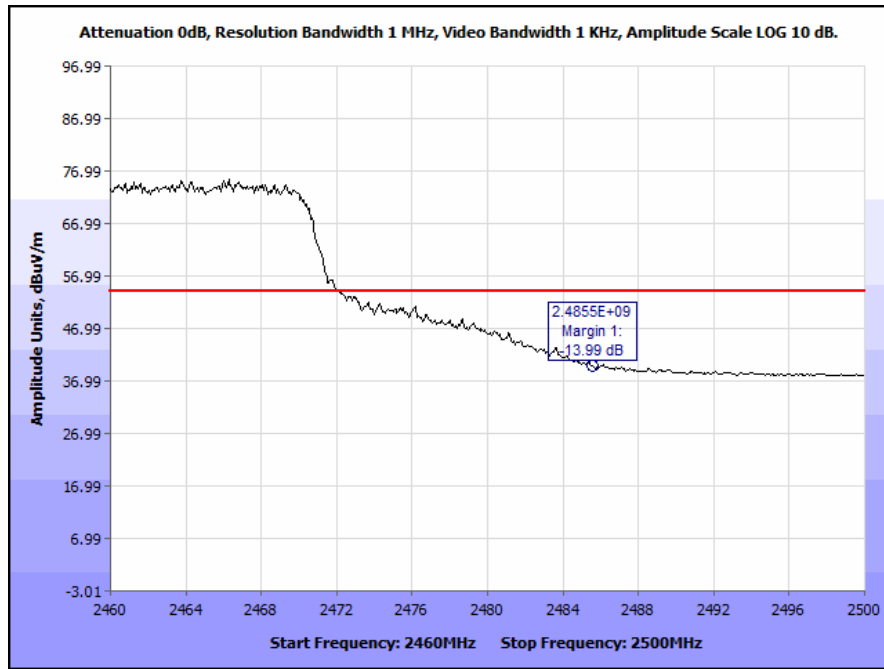

Plot 44. Radiated Band Edge, 802.11g, Channel 11, Average

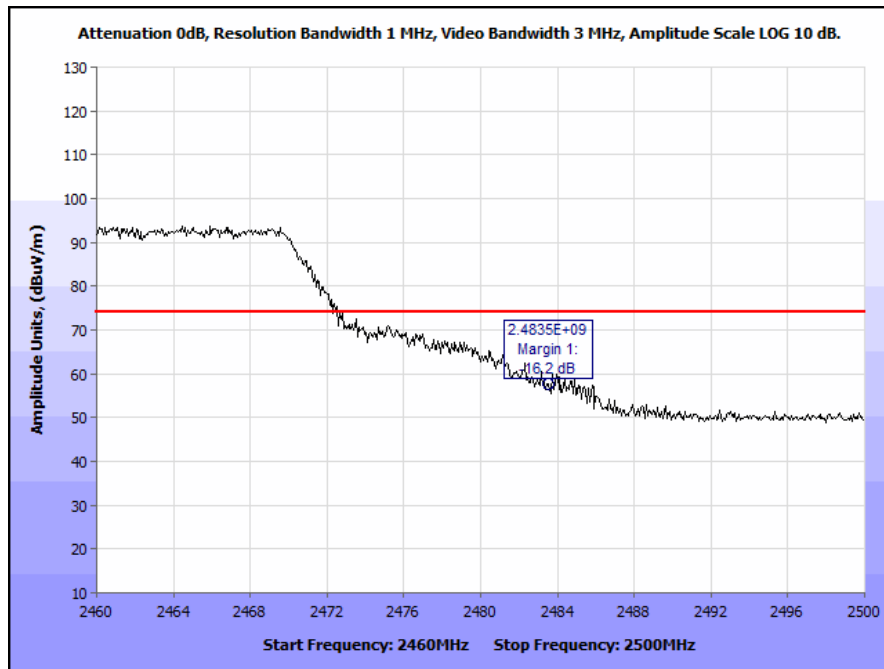

Plot 45. Radiated Band Edge, 802.11g, Channel 11, Peak

Electromagnetic Compatibility Criteria for Intentional Radiators

§ 15.247(d) RF Conducted Spurious Emissions Requirements and Band Edge

Test Requirement: **15.247(d)** In any 100 kHz bandwidth outside the frequency band in which the spread spectrum or digitally modulated intentional radiator is operating, the radio frequency power that is produced by the intentional radiator shall be at least 20 dB below that in the 100 kHz bandwidth within the band that contains the highest level of the desired power, based on either an RF conducted or a radiated measurement, provided the transmitter demonstrates compliance with the peak conducted power limits. If the transmitter complies with the conducted power limits based on the use of RMS averaging over a time interval, as permitted under paragraph (b)(3) of this section, the attenuation required under this paragraph shall be 30 dB instead of 20 dB.

Test Procedure: For intentional radiators with a digital device portion which operates below 10 GHz, the spectrum was investigated as per §15.33(a)(1) and §15.33(a)(4); i.e., the lowest RF signal generated or used in the device up to the 10th harmonic of the highest fundamental frequency or to 40 GHz, whichever is lower.

See following pages for detailed test results with RF Conducted Spurious Emissions.

Test Results: The EUT was compliant with the Conducted Spurious Emission limits of §15.247(d).

Test Engineer(s): Andy Shen

Test Date(s): 10/30/14

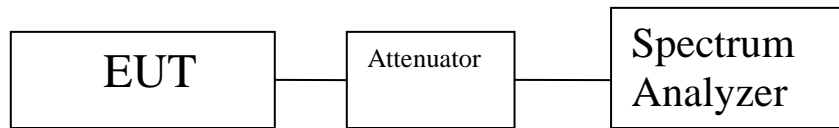
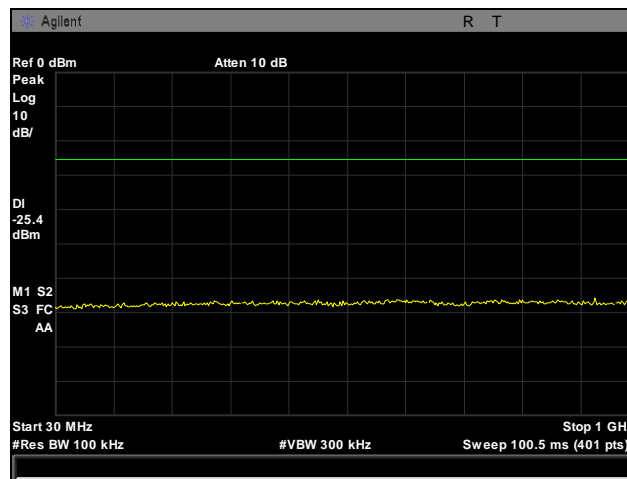
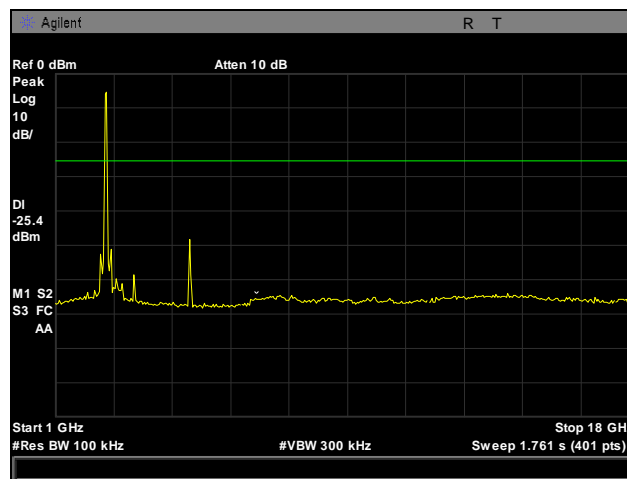

Figure 4. Block Diagram, Conducted Spurious Emissions Test Setup

Conducted Spurious Emissions Test Results, 802.11b



Plot 46. Conducted Spurious Emissions, Low Channel, 2412 MHz, 802.11b, 30 MHz – 1 GHz



Plot 47. Conducted Spurious Emissions, Low Channel, 2412 MHz, 802.11b, 1 GHz – 18 GHz

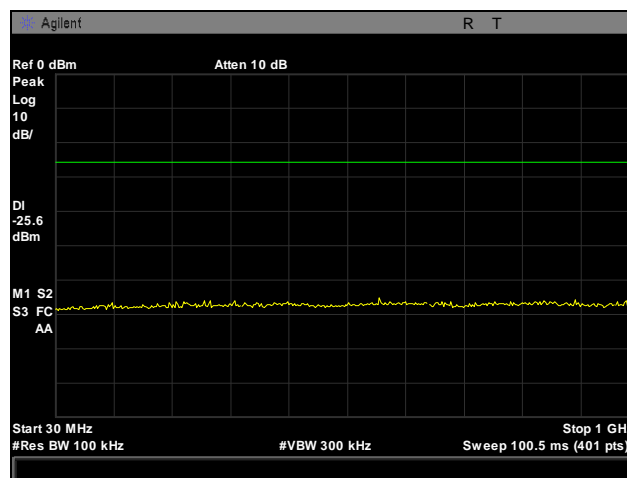

Plot 48. Conducted Spurious Emissions, Mid Channel, 2442 MHz, 802.11b, 30 MHz – 1 GHz

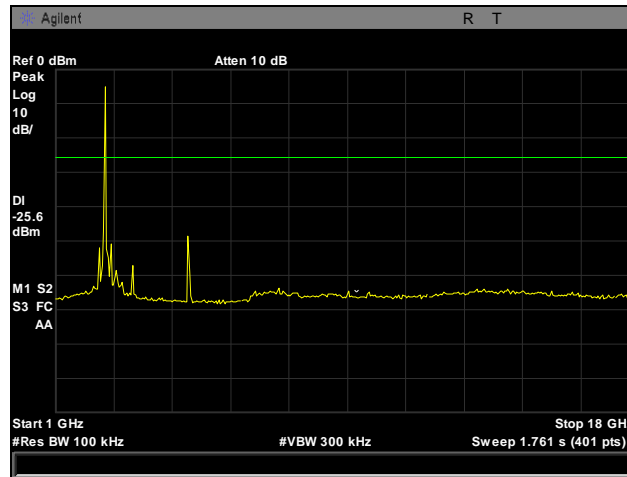

Plot 49. Conducted Spurious Emissions, Mid Channel, 2442 MHz, 802.11b, 1 GHz – 18 GHz

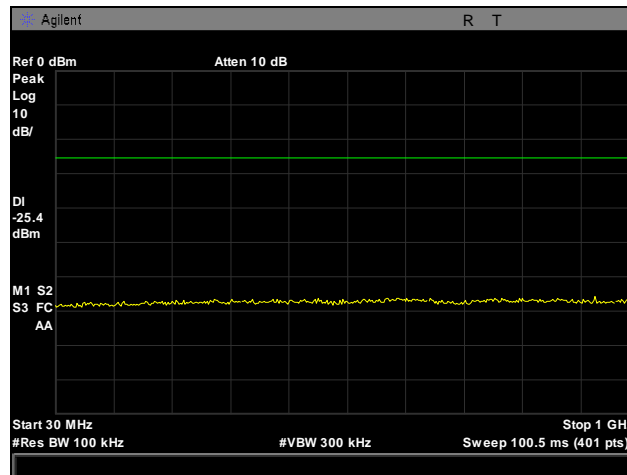

Plot 50. Conducted Spurious Emissions, High Channel, 2462 MHz, 802.11b, 30 MHz – 1 GHz

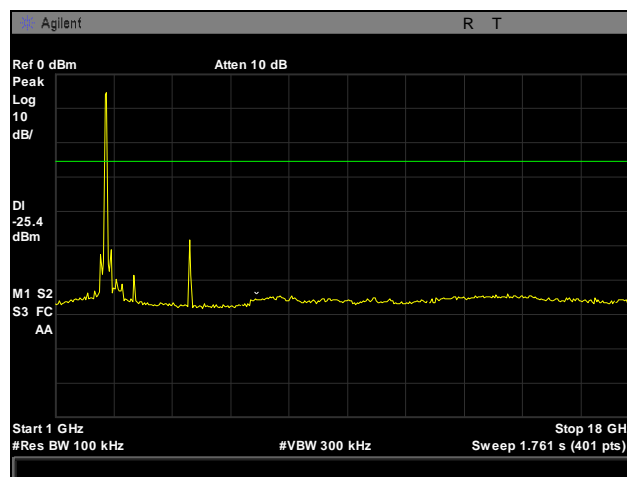

Plot 51. Conducted Spurious Emissions, High Channel, 2462 MHz, 802.11b, 1 GHz – 18 GHz

Conducted Spurious Emissions Test Results, 802.11g

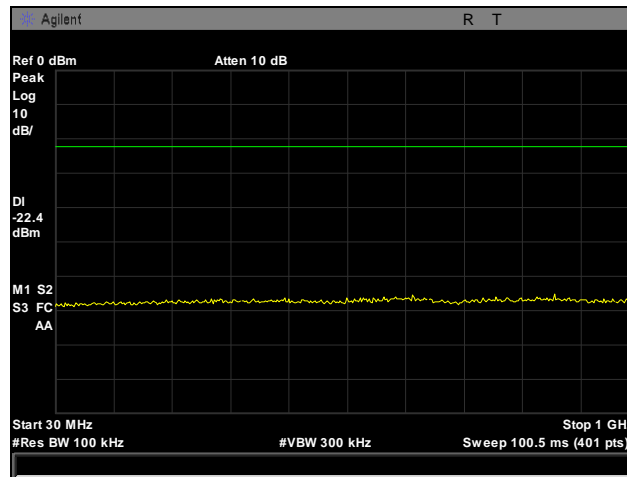

Plot 52. Conducted Spurious Emissions, Low Channel, 2412 MHz, 802.11g, 30 MHz – 1 GHz

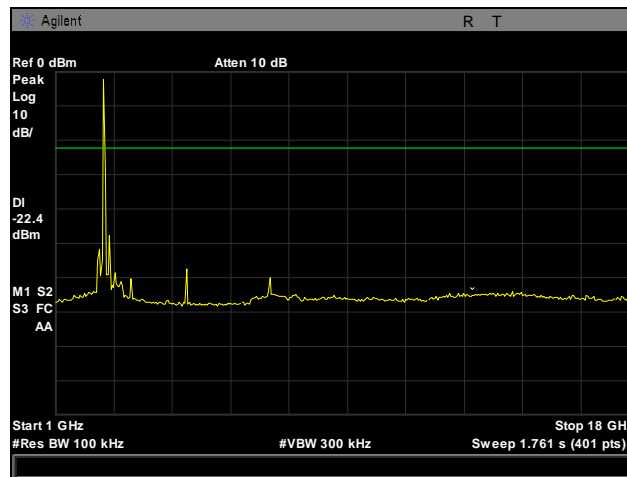

Plot 53. Conducted Spurious Emissions, Low Channel, 2412 MHz, 802.11g, 1 GHz – 18 GHz

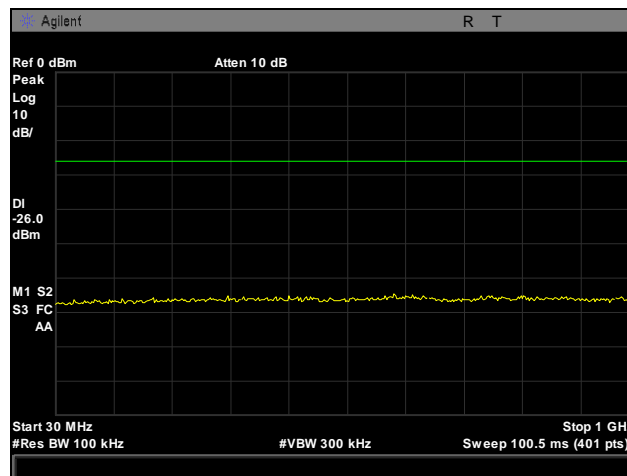

Plot 54. Conducted Spurious Emissions, Mid Channel, 2442 MHz, 802.11g, 30 MHz – 1 GHz

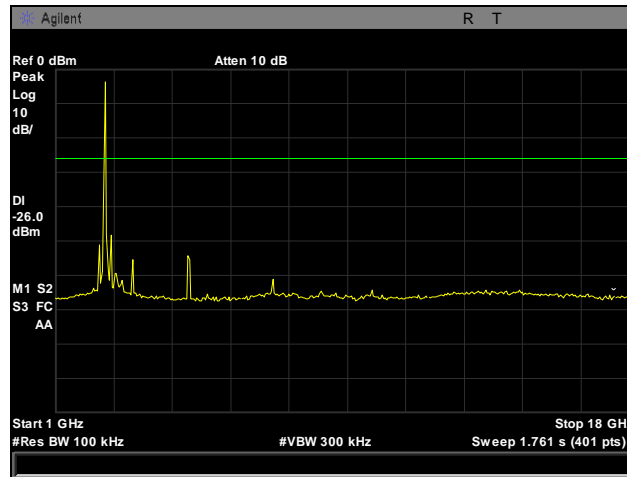

Plot 55. Conducted Spurious Emissions, Mid Channel, 2442 MHz, 802.11g, 1 GHz – 18 GHz

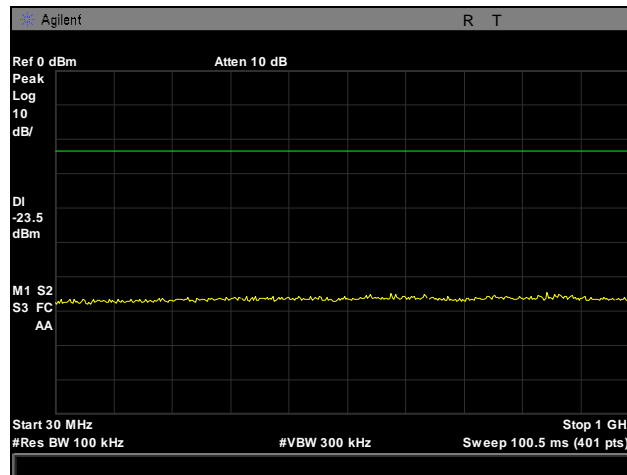

Plot 56. Conducted Spurious Emissions, High Channel, 2462 MHz, 802.11g, 30 MHz – 1 GHz

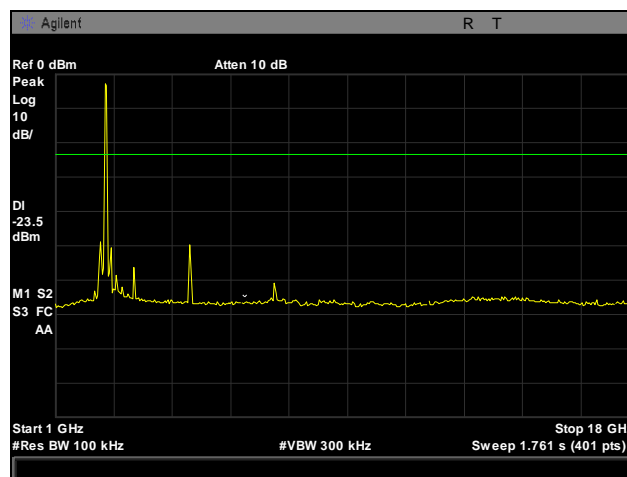

Plot 57. Conducted Spurious Emissions, High Channel, 2462 MHz, 802.11g, 1 GHz – 18 GHz

Conducted Band Edge Test Results, 802.11b

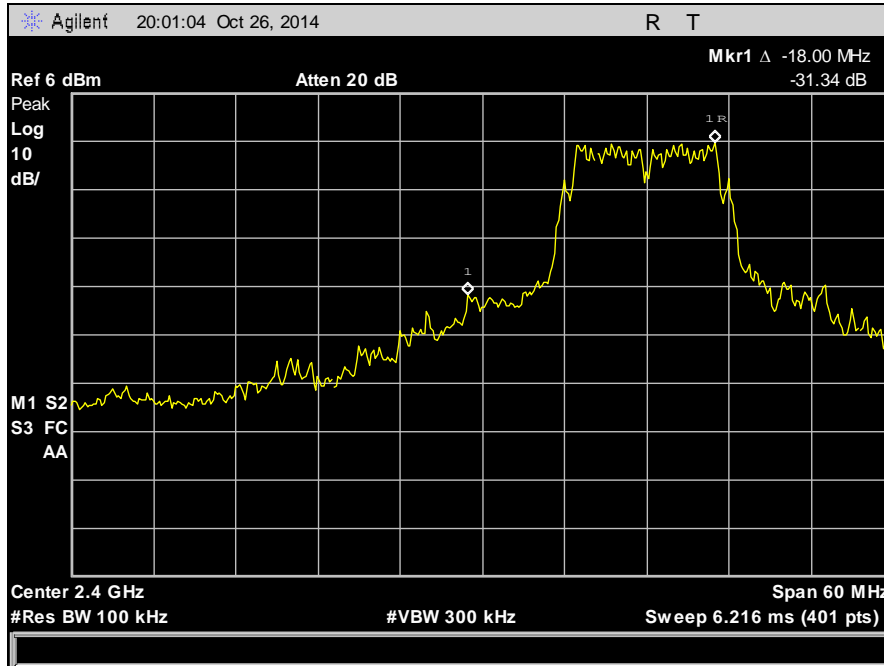

Plot 58. Conducted Band Edge, Low Channel, 2412 MHz, 802.11b

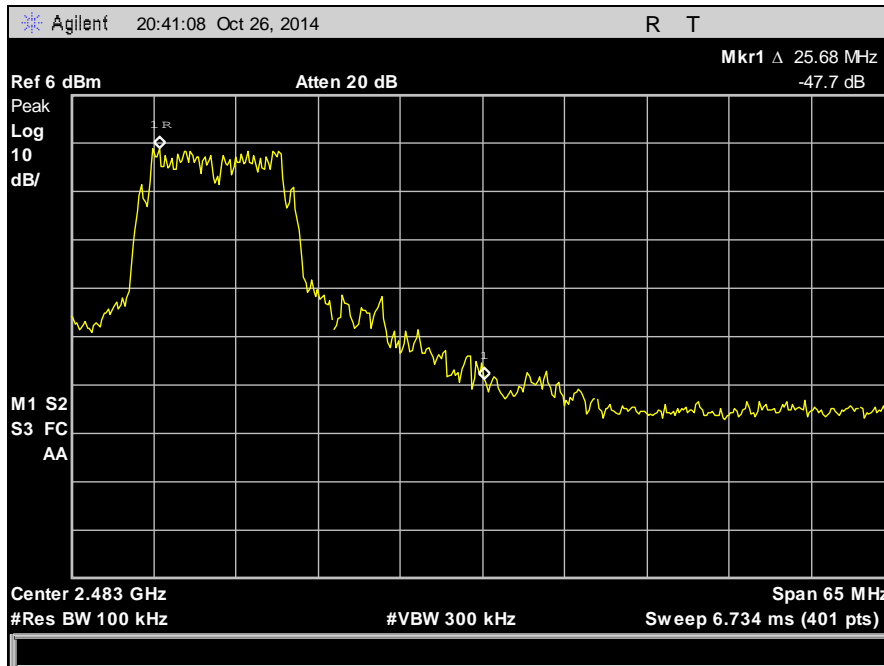

Plot 59. Conducted Band Edge, High Channel, 2462 MHz, 802.11b

Conducted Band Edge Test Results, 802.11g

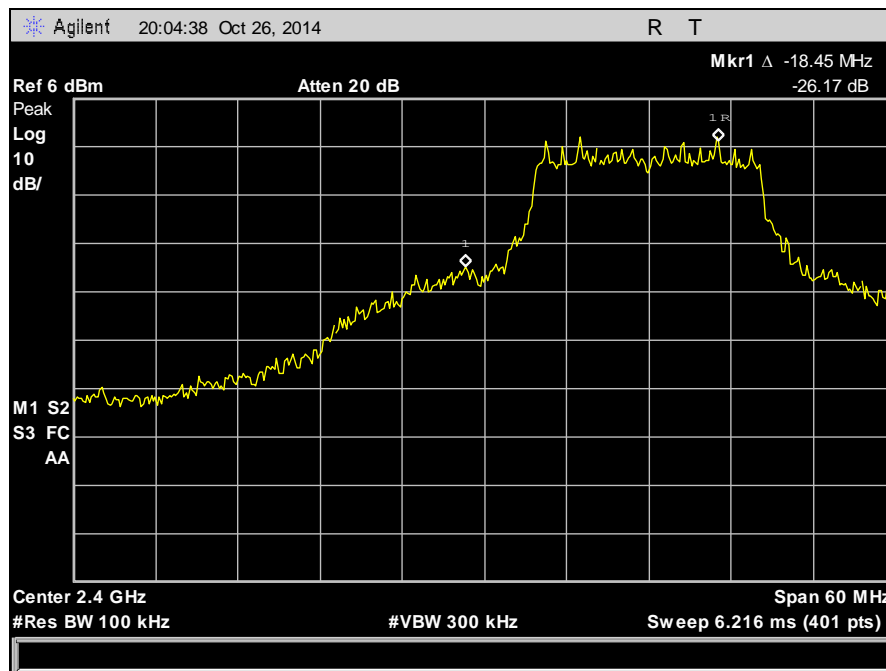

Plot 60. Conducted Band Edge, Low Channel, 2412 MHz, 802.11g

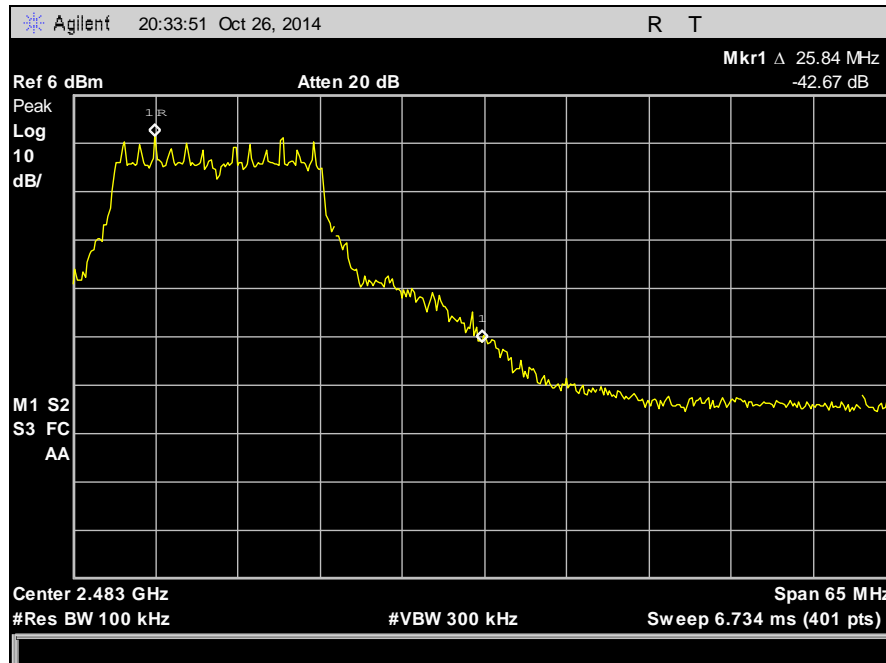

Plot 61. Conducted Band Edge, High Channel, 2462 MHz, 802.11g

Electromagnetic Compatibility Criteria for Intentional Radiators

§ 15.247(e) Peak Power Spectral Density

Test Requirements: §15.247(e): For digitally modulated systems, the peak power spectral density conducted from the intentional radiator to the antenna shall not be greater than 8dBm in any 3 kHz band during any time interval of continuous transmission.

Test Procedure: The transmitter was connected directly to a Spectrum Analyzer through an attenuator. The power level was set to the maximum level. A RBW of 1 MHz and VBW of 3 MHz were used to determine the peak emissions within the band. The Spectrum analyzer was then set to a RBW of 3 kHz and VBW was set to 10 kHz. The SPAN of the analyzer was set to 1 MHz. Measurements were carried out at the low, mid and high channels.

Test Results: The EUT was compliant with the peak power spectral density limits of § 15.247 (e).

The peak power spectral density was determined from plots on the following page(s).

Test Engineer: Andy Shen

Test Date: 10/30/14

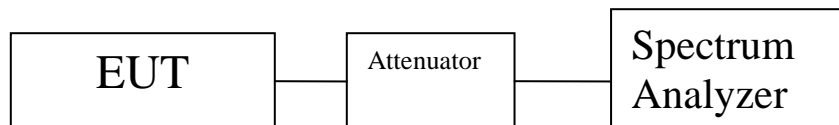
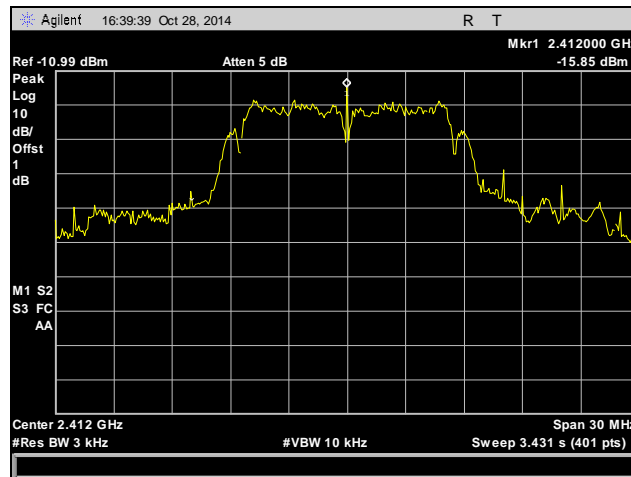
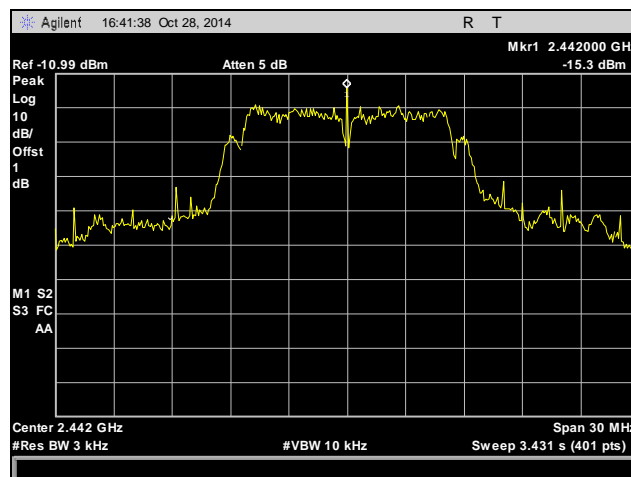

Figure 5. Block Diagram, Peak Power Spectral Density Test Setup

Peak Power Spectral Density, 802.11b



Plot 62. Peak Power Spectral Density, Low Channel, 2412 MHz, 802.11b



Plot 63. Peak Power Spectral Density, Mid Channel, 2442 MHz, 802.11b

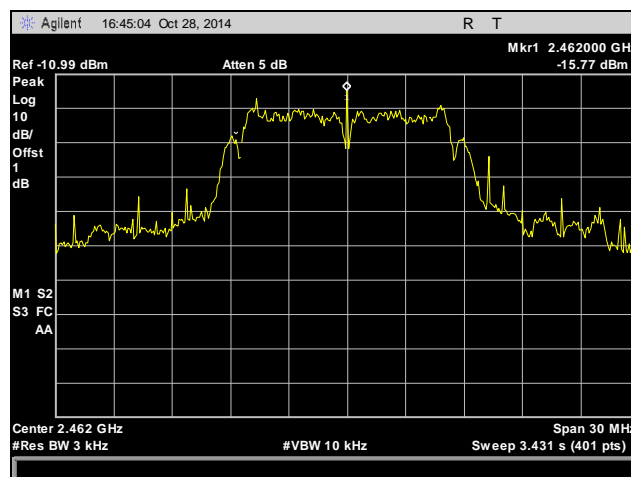

Plot 64. Peak Power Spectral Density, High Channel, 2462 MHz, 802.11b

Peak Power Spectral Density, 802.11g

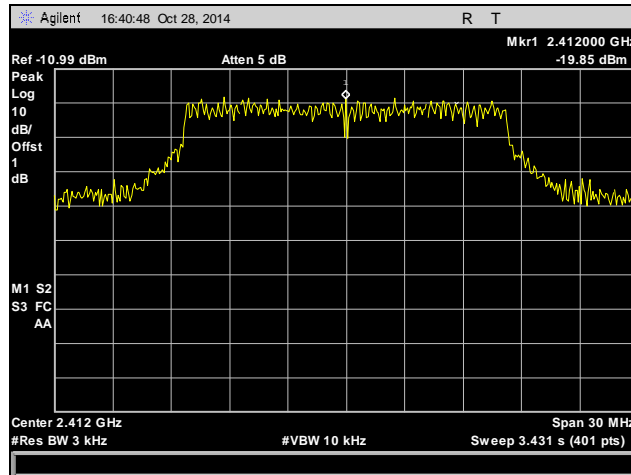

Plot 65. Peak Power Spectral Density, Low Channel, 2412 MHz, 802.11g

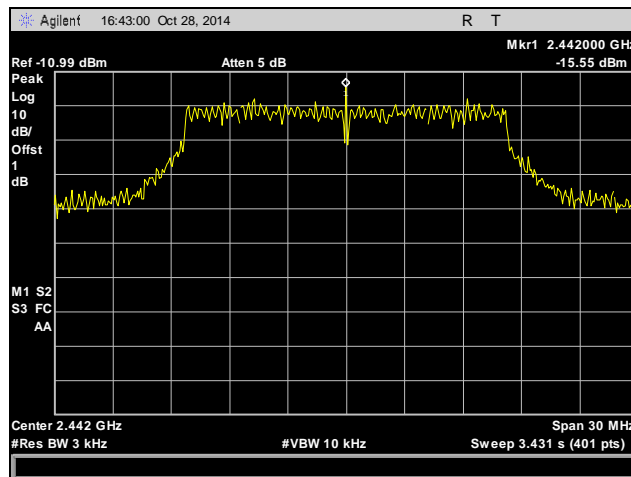

Plot 66. Peak Power Spectral Density, Mid Channel, 2442 MHz, 802.11g

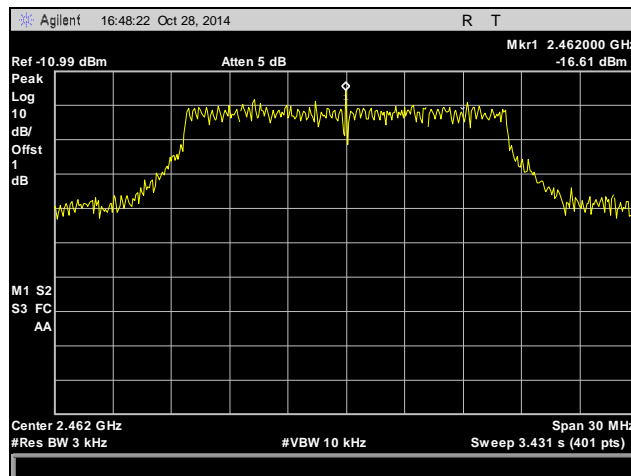

Plot 67. Peak Power Spectral Density, High Channel, 2462 MHz, 802.11g

Electromagnetic Compatibility Criteria for Intentional Radiators

§ 15.247(i) Maximum Permissible Exposure

RF Exposure Requirements: §1.1307(b)(1) and §1.1307(b)(2): Systems operating under the provisions of this section shall be operated in a manner that ensures that the public is not exposed to radio frequency energy levels in excess of the Commission's guidelines.

RF Radiation Exposure Limit: §1.1310: As specified in this section, the Maximum Permissible Exposure (MPE) Limit shall be used to evaluate the environmental impact of human exposure to radiofrequency (RF) radiation as specified in Sec. 1.1307(b), except in the case of portable devices which shall be evaluated according to the provisions of Sec. 2.1093 of this chapter.

2.4 GHz highest power density:
EUT antenna gain = 0 dBi;
Power = 5.21 mW

$$S = PG / 4\pi R^2 \quad \text{or} \quad R = \sqrt{PG / 4\pi S}$$

where,
S = Power Density
P = Power Input to antenna
G = Antenna Gain (1 numeric)
R = 20 cm

$$S = (5.21 * 1 / 4 * 3.14 * 400) = 0.001037 \text{ mW/cm}^2$$

IV. Test Equipment

Test Equipment

Calibrated test equipment utilized during testing was maintained in a current state of calibration per the requirements of ISO/IEC 17025:2005.

MET Asset #	Equipment	Manufacturer	Model	Last Cal Date	Cal Due Date
1S2460	1-26GHZ SPECTRUM ANALYZER	AGILENT TECHNOLOGIES	E4407B	2/27/2014	8/27/2015
1S3853	DIGITAL DC POWER SUPPLY	EXTECH INSTRUMENTS	382200	SEE NOTE	
1S2482	5 METER CHAMBER (NSA)	PANASHIELD	5 METER SEMI-ANECHOIC CHAMBER	8/12/2013	2/12/2015
1S2600	BILOG ANTENNA	TESEQ	CBL6112D	8/29/2013	8/29/2015
1S2603	DOUBLE RIDGED WAVEGUIDE HORN	ETS-LINDGREN	3117	4/24/2013	4/24/2015
1S2421	EMI TEST RECEIVER	ROHDE & SCHWARZ	ESIB7	9/10/2014	9/10/2015
1S3835	PSA SPECTRUM ANALYZER	AGILENT	E4448A	9/24/2014	9/24/2015

Table 17. Test Equipment List

Note: Functionally tested equipment is verified using calibrated instrumentation at the time of testing.

V. Certification & User's Manual Information

Certification & User's Manual Information

A. Certification Information

The following is extracted from Title 47 of the Code of Federal Regulations, Part 2, Subpart I — Marketing of Radio frequency devices:

§ 2.801 Radio-frequency device defined.

As used in this part, a radio-frequency device is any device which in its operation is capable of Emitting radio-frequency energy by radiation, conduction, or other means. Radio- frequency devices include, but are not limited to:

- (a) The various types of radio communication transmitting devices described throughout this chapter.
- (b) *The incidental, unintentional and intentional radiators defined in Part 15 of this chapter.*
- (c) The industrial, scientific, and medical equipment described in Part 18 of this chapter.
- (d) Any part or component thereof which in use emits radio-frequency energy by radiation, conduction, or other means.

§ 2.803 Marketing of radio frequency devices prior to equipment authorization.

- (a) Except as provided elsewhere in this chapter, no person shall sell or lease, or offer for sale or lease (including advertising for sale or lease), or import, ship or distribute for the purpose of selling or leasing or offering for sale or lease, any radio frequency device unless:
 - (1) In the case of a device subject to certification, such device has been authorized by the Commission in accordance with the rules in this chapter and is properly identified and labeled as required by §2.925 and other relevant sections in this chapter; or
 - (2) In the case of a device that is not required to have a grant of equipment authorization issued by the Commission, but which must comply with the specified technical standards prior to use, such device also complies with all applicable administrative (including verification of the equipment or authorization under a Declaration of Conformity, where required), technical, labeling and identification requirements specified in this chapter.
- (d) Notwithstanding the provisions of paragraph (a) of this section, the offer for sale solely to business, commercial, industrial, scientific or medical users (but not an offer for sale to other parties or to end users located in a residential environment) of a radio frequency device that is in the conceptual, developmental, design or pre-production stage is permitted prior to equipment authorization or, for devices not subject to the equipment authorization requirements, prior to a determination of compliance with the applicable technical requirements *provided* that the prospective buyer is advised in writing at the time of the offer for sale that the equipment is subject to the FCC rules and that the equipment will comply with the appropriate rules before delivery to the buyer or to centers of distribution.

- (e)(1) Notwithstanding the provisions of paragraph (a) of this section, prior to equipment authorization or determination of compliance with the applicable technical requirements any radio frequency device may be operated, but not marketed, for the following purposes and under the following conditions:
- (i) *Compliance testing*;
 - (ii) Demonstrations at a trade show provided the notice contained in paragraph (c) of this section is displayed in a conspicuous location on, or immediately adjacent to, the device;
 - (iii) Demonstrations at an exhibition conducted at a business, commercial, industrial, scientific or medical location, but excluding locations in a residential environment, provided the notice contained in paragraphs (c) or (d) of this section, as appropriate, is displayed in a conspicuous location on, or immediately adjacent to, the device;
 - (iv) Evaluation of product performance and determination of customer acceptability, provided such operation takes place at the manufacturer's facilities during developmental, design or pre-production states; or
 - (v) Evaluation of product performance and determination of customer acceptability where customer acceptability of a radio frequency device cannot be determined at the manufacturer's facilities because of size or unique capability of the device, provided the device is operated at a business, commercial, industrial, scientific or medical user's site, but not at a residential site, during the development, design or pre-production stages.
- (e)(2) For the purpose of paragraphs (e)(1)(iv) and (e)(1)(v) of this section, the term *manufacturer's facilities* includes the facilities of the party responsible for compliance with the regulations and the manufacturer's premises, as well as the facilities of other entities working under the authorization of the responsible party in connection with the development and manufacture, but not the marketing, of the equipment.
- (f) For radio frequency devices subject to verification and sold solely to business, commercial, industrial, scientific and medical users (excluding products sold to other parties or for operation in a residential environment), parties responsible for verification of the devices shall have the option of ensuring compliance with the applicable technical specifications of this chapter at each end user's location after installation, provided that the purchase or lease agreement includes a proviso that such a determination of compliance be made and is the responsibility of the party responsible for verification of the equipment.

Certification & User's Manual Information

The following is extracted from Title 47 of the Code of Federal Regulations, Part 2, Subpart J — Equipment Authorization Procedures:

§ 2.901 Basis and Purpose

- (a) In order to carry out its responsibilities under the Communications Act and the various treaties and international regulations, and in order to promote efficient use of the radio spectrum, the Commission has developed technical standards for radio frequency equipment and parts or components thereof. The technical standards applicable to individual types of equipment are found in that part of the rules governing the service wherein the equipment is to be operated.¹ *In addition to the technical standards provided, the rules governing the service may require that such equipment be verified by the manufacturer or importer, be authorized under a Declaration of Conformity, or receive an equipment authorization from the Commission by one of the following procedures: certification or registration.*
- (b) The following sections describe the verification procedure, the procedure for a Declaration of Conformity, and the procedures to be followed in obtaining certification from the Commission and the conditions attendant to such a grant.

§ 2.907 Certification.

- (a) Certification is an equipment authorization issued by the Commission, based on representation and test data submitted by the applicant.
- (b) Certification attaches to all units subsequently marketed by the grantee which are identical (see Section 2.908) to the sample tested except for permissive changes or other variations authorized by the Commission pursuant to Section 2.1043.

¹ In this case, the equipment is subject to the rules of Part 15. More specifically, the equipment falls under Subpart B (of Part 15), which deals with unintentional radiators.

Certification & User's Manual Information

§ 2.948 Description of measurement facilities.

- (a) Each party making measurements of equipment that is subject to an equipment authorization under Part 15 or Part 18 of this chapter, regardless of whether the measurements are filed with the Commission or kept on file by the party responsible for compliance of equipment marketed within the U.S. or its possessions, shall compile a description of the measurement facilities employed.
- (1) If the measured equipment is subject to the verification procedure, the description of the measurement facilities shall be retained by the party responsible for verification of the equipment.
- (i) *If the equipment is verified through measurements performed by an independent laboratory, it is acceptable for the party responsible for verification of the equipment to rely upon the description of the measurement facilities retained by or placed on file with the Commission by that laboratory. In this situation, the party responsible for the verification of the equipment is not required to retain a duplicate copy of the description of the measurement facilities.*
- (ii) If the equipment is verified based on measurements performed at the installation site of the equipment, no specific site calibration data is required. It is acceptable to retain the description of the measurement facilities at the site at which the measurements were performed.
- (2) If the equipment is to be authorized by the Commission under the certification procedure, the description of the measurement facilities shall be filed with the Commission's Laboratory in Columbia, Maryland. The data describing the measurement facilities need only be filed once but must be updated as changes are made to the measurement facilities or as otherwise described in this section. At least every three years, the organization responsible for filing the data with the Commission shall certify that the data on file is current.

Certification & User's Manual Information

1. Label and User's Manual Information

The following is extracted from Title 47 of the Code of Federal Regulations, Part 15, Subpart A — General:

§ 15.19 Labeling requirements.

(a) *In addition to the requirements in Part 2 of this chapter, a device subject to certification or verification shall be labeled as follows:*

- (1) Receivers associated with the operation of a licensed radio service, e.g., FM broadcast under Part 73 of this chapter, land mobile operation under Part 90, etc., shall bear the following statement in a conspicuous location on the device:

This device complies with Part 15 of the FCC Rules. Operation is subject to the condition that this device does not cause harmful interference.

- (2) A stand-alone cable input selector switch, shall bear the following statement in a conspicuous location on the device:

This device is verified to comply with Part 15 of the FCC Rules for use with cable television service.

- (3) All other devices shall bear the following statement in a conspicuous location on the device:

This device complies with Part 15 of the FCC Rules. Operation is subject to the following two conditions: (1) This device may not cause harmful interference, and (2) this device must accept any interference received, including interference that may cause undesired operation.

- (4) Where a device is constructed in two or more sections connected by wires and marketed together, the statement specified under paragraph (a) of this section is required to be affixed only to the main control unit.

- (5) When the device is so small or for such use that it is not practicable to place the statement specified under paragraph (a) of this section on it, the information required by this paragraph shall be placed in a prominent location in the instruction manual or pamphlet supplied to the user or, alternatively, shall be placed on the container in which the device is marketed. However, the FCC identifier or the unique identifier, as appropriate, must be displayed on the device.

§ 15.21 Information to user.

The user's manual or instruction manual for an intentional or unintentional radiator shall caution the user that changes or modifications not expressly approved by the party responsible for compliance could void the user's authority to operate the equipment.

Verification & User's Manual Information

The following is extracted from Title 47 of the Code of Federal Regulations, Part 15, Subpart B — Unintentional Radiators:

§ 15.105 Information to the user.

- (a) For a Class A digital device or peripheral, the instructions furnished the user shall include the following or similar statement, placed in a prominent location in the text of the manual:

Note: This equipment has been tested and found to comply with the limits for a Class A digital device, pursuant to Part 15 of the FCC Rules. These limits are designed to provide reasonable protection against harmful interference when the equipment is operated in a commercial environment. This equipment generates, uses, and can radiate radio frequency energy and, if not installed and used in accordance with the instruction manual, may cause harmful interference to radio communications. Operation of this equipment in a residential area is likely to cause harmful interference in which case the user will be required to correct the interference at own expense.

- (b) For a Class B digital device or peripheral, the instructions furnished the user shall include the following or similar statement, placed in a prominent location in the text of the manual:

Note: This equipment has been tested and found to comply with the limits for a Class B digital device, pursuant to Part 15 of the FCC Rules. These limits are designed to provide reasonable protection against harmful interference when the equipment is operated in a residential environment. This equipment generates, uses, and can radiate radio frequency energy and, if not installed and used in accordance with the instruction manual, may cause harmful interference to radio communications. However, there is no guarantee that interference will not occur in a particular installation. If this equipment does cause harmful interference to radio or television reception, which can be determined by turning the equipment off and on, the user is encouraged to try to correct the interference by one or more of the following measures:

- Reorient or relocate the receiving antenna.
- Increase the separation between the equipment and receiver.
- Connect the equipment into an outlet on a circuit different from that to which the receiver is connected.
- Consult the dealer or an experienced radio/TV technician for help.

ICES-003 Procedural & Labeling Requirements

From the Industry Canada Electromagnetic Compatibility Advisory Bulletin entitled, "Implementation and Interpretation of the Interference-Causing Equipment Standard for Digital Apparatus, ICES-003" (EMCAB-3, Issue 2, July 1995):

"At present, CISPR 22: 2002 and ICES technical requirements are essentially equivalent. Therefore, if you have CISPR 22: 2002 approval by meeting CISPR Publication 22, the only additional requirements are: to attach a note to the report of the test results for compliance, indicating that these results are deemed satisfactory evidence of compliance with ICES-003 of the Canadian Interference-Causing Equipment Regulations; to maintain these records on file for the requisite five year period; and to provide the device with a notice of compliance in accordance with ICES-003."

Procedural Requirements:

According to Industry Canada's Interference Causing Equipment Standard for Digital Apparatus ICES-003 Issue 5 August 2012:

- Section 6.1: A record of the measurements and results, showing the date that the measurements were completed, shall be retained by the manufacturer or importer for a period of at least five years from the date shown in the record and made available for examination on the request of the Minister.
- Section 6.2: A written notice indicating compliance must accompany each unit of digital apparatus to the end user. The notice shall be in the form of a label that is affixed to the apparatus. Where because of insufficient space or other constraints it is not feasible to affix a label to the apparatus, the notice may be in the form of a statement in the users' manual.

Labeling Requirements:

The suggested text for the notice, in English and in French, is provided below, from the Annex of ICES-003:

This Class [²] digital apparatus complies with Canadian ICES-003.

Cet appareil numérique de la classe [¹] est conforme à la norme NMB-003 du Canada.

² Insert either A or B but not both as appropriate for the equipment requirements.

End of Report