

Test Report

FCC Part15 Subpart C

Product Name : IP-STB
Model No. : 4400X
FCC ID : TC2-R1010
IC : 5959A-R1010

Applicant : Roku Inc.

Address : 12980 Saratoga Ave, Suite D Saratoga, CA 95070

Date of Receipt : Aug. 31, 2015
Test Date : Aug. 31, 2015~ Sept. 17, 2015
Issued Date : Sept. 22, 2015
Report No. : 1590118R-RF-US-P06V02
Report Version : V 1.0

The test results relate only to the samples tested.

The test results shown in the test report are traceable to the national/international standard through the calibration of the equipment and evaluated measurement uncertainty herein.

This report must not be used to claim product endorsement by any agency of the government.

The test report shall not be reproduced without the written approval of QuieTek Corporation.

Test Report Certification

Issued Date : Sept. 22, 2015

Report No. : 1590118R-RF-US-P06V02



Product Name : IP-STB
Applicant : Roku Inc.
Address : 12980 Saratoga Ave, Suite D Saratoga, CA 95070
Manufacturer : Ambit Mircosystems (Shanghai) LTD.
Address : 1925, Nanle Road, Songjiang Export Processing Zone,
Shanghai, China 201613
Model No. : 4400X
FCC ID : TC2-R1010
IC : 5959A-R1010
EUT Voltage : DC 12V
Brand Name : Roku
Applicable Standard : FCC CFR Title 47 Part 15 Subpart C: 2015
ANSI C63.4:2014;
ANSI C63.10:2013;
KDB 558074 D01v03r03
Industry Canada RSS-Gen Issue 4
Industry Canada RSS-247 Issue 1
Test Result : Complied
Performed Location : Suzhou EMC Laboratory
No.99 Hongye Rd., Suzhou Industrial Park, Suzhou, 215006,
Jiangsu, China
TEL: +86-512-6251-5088 / FAX: +86-512-6251-5098
FCC Registration Number: 800392; IC Lab Code: 4075B

Documented By : *Zhenrong*

Reviewed By : *Harry zhou*

Approved By : *Dream Cao*

Laboratory Information

We, **Quietek Corporation**, are an independent EMC and safety consultancy that was established the whole facility in our laboratories. The test facility has been accredited/accepted(audited or listed) by the following related bodies in compliance with ISO 17025, EN 45001 and specified testing scope:

Taiwan R.O.C.	:	BSMI, NCC,TAF
USA	:	FCC
Japan	:	VCCI
China	:	CNAS

The related certificate for our laboratories about the test site and management system can be downloaded from Quietek Corporation's Web Site :<http://www.quietek.com/tw/ctg/cts/accreditations.htm>

The address and introduction of Quietek Corporation's laboratories can be founded in our Web site :
<http://www.quietek.com/>

If you have any comments, Please don't hesitate to contact us. Our contact information is as below:

HsinChu Testing Laboratory :

No.75-2, 3rd Lin, Wangye Keng, Yonghxing Tsuen, Qionglin Shiang, Hsinchu County 307, Taiwan, R.O.C.
TEL:+886-3-592-8858 / FAX:+886-3-592-8859 E-Mail : service@quietek.com

LinKou Testing Laboratory :

No.5-22, Ruishukeng, Linkou Dist., New Taipei City 24451, Taiwan, R.O.C.
TEL : 886-2-8601-3788 / FAX : 886-2-8601-3789 E-Mail : service@quietek.com

Suzhou Testing Laboratory :

No.99 Hongye Rd., Suzhou Industrial Park, Suzhou, 215006, Jiangsu,China
TEL : +86-512-6251-5088 / FAX : 86-512-6251-5098 E-Mail : service@quietek.com

TABLE OF CONTENTS

Description	Page
1. General Information	8
1.1. EUT Description	8
1.1. Mode of Operation	12
1.2. Tested System Details.....	13
1.3. Configuration of Tested System	14
1.4. EUT Exercise Software	15
2. Technical Test.....	16
2.1. Summary of Test Result	16
2.2. Test Environment	18
3. Conducted Emission	19
3.1. Test Equipment	19
3.2. Test Setup	19
3.3. Limit.....	20
3.4. Test Procedure	20
3.5. Uncertainty	20
3.6. Test Result	21
4. Radiated Emission	23
4.1. Test Equipment	23
4.2. Test Setup	24
4.3. Limit.....	25
4.4. Test Procedure	25
4.5. Uncertainty	26
4.6. Test Result	27
5. 20dB Bandwidth	32
5.1. Test Equipment	32
5.2. Test Setup	32
5.3. Limit.....	32
5.4. Test Procedure	33
5.5. Uncertainty	33
5.6. Test Result	34
6. Carrier Frequency Separation.....	40
6.1. Test Equipment	40
6.2. Test Setup	40
6.3. Limit.....	40
6.4. Test Procedure	41
6.5. Uncertainty	41
6.6. Test Result	42

7.	Number of Hopping Frequencies	48
7.1.	Test Equipment	48
7.2.	Test Setup	48
7.3.	Limit.....	48
7.4.	Test Procedure	49
7.5.	Uncertainty	49
7.6.	Test Result	50
8.	Time of Occupancy (Dwell Time)	59
8.1.	Test Equipment	59
8.2.	Test Setup	59
8.3.	Limit.....	59
8.4.	Test Procedure	60
8.5.	Uncertainty	60
8.6.	Test Result	61
9.	Peak Output Power	67
9.1.	Test Equipment	67
9.2.	Test Setup	67
9.3.	Limit.....	67
9.4.	Test Procedure	68
9.5.	Uncertainty	68
9.6.	Test Result	69
10.	Band-edge Compliance of RF Conducted Emissions	75
10.1.	Test Equipment	75
10.2.	Test Setup	75
10.3.	Limit.....	75
10.4.	Test Procedure	76
10.5.	Uncertainty	76
10.6.	Test Result	77
11.	Spurious RF Conducted Emissions.....	81
11.1.	Test Equipment	81
11.2.	Test Setup	81
11.3.	Limit.....	81
11.4.	Test Procedure	82
11.5.	Uncertainty	82
11.6.	Test Result	83
12.	Radiated Emission Band Edge	89
12.1.	Test Equipment	89
12.2.	Test Setup	90

12.3. Limit.....	90
12.4. Test Procedure	90
12.5. Uncertainty	91
12.6. Test Result	92

History of This Test Report

REPORT NO.	VERSION	DESCRIPTION	ISSUED DATE
1590118R-RF-US-P06V02	V1.0	Initial Issued Report	Sept. 22, 2015

1. General Information

1.1. EUT Description

Product Name	IP-STB
Brand Name	Roku
Model No.	4400X
EUT Voltage	DC 12V
WIFI	
Frequency Range	<p>For 2.4GHz Band</p> <p>802.11b/g/n(20MHz): 2412~2462MHz</p> <p>802.11n(40MHz): 2422~2452MHz</p> <p>For 5.0GHz Band</p> <p>802.11a/n/ac(20MHz): 5180~5240MHz, 5745~5825MHz</p> <p>802.11n/ac(40MHz): 5190~5230MHz, 5755~5795MHz</p> <p>802.11ac(80MHz): 5210MHz,5775MHz</p>
Channel Number	<p>For 2.4GHz Band</p> <p>802.11b/g/n(20MHz): 11</p> <p>802.11n(40MHz): 7</p> <p>For 5GHz Band</p> <p>802.11a/n(20MHz)/ac(20MHz): 9 802.11n(40MHz)/ac(40MHz): 4</p> <p>802.11ac(80MHz): 2</p>
Type of Modulation	<p>802.11b: DSSS</p> <p>802.11a/g/n: OFDM</p>
Data Rate	<p>802.11a/g: 6/9/12/18/24/36/48/54 Mbps</p> <p>802.11b: 1/2/5.5/11 Mbps</p> <p>802.11n: up to 300 Mbps</p> <p>802.11ac: up to 866.6 Mbps</p>
Channel Control	Auto
Antenna Delivery	2*Tx + 2*Rx
Bluetooth	
Bluetooth Specification	3.0 + Version 4.0
Frequency Range	2402- 2480 MHz
Channel Number	<p>V3.0+HS: 79</p> <p>V4.0: 40</p>
Channel Separation	<p>V3.0+HS: 1MHz</p> <p>V4.0: 2MHz</p>
Type of Modulation	V3.0: GFSK, Pi/4 DQPSK, 8DPSK

	V4.0: GFSK
Data Rate	V3.0: 1Mbps(GFSK), 2Mbps(Pi/4 DQPSK), 3Mbps (8DPSK) V4.0: 1Mbps
Antenna Type	Reference to Antenna List
Peak Antenna Gain	Reference to Antenna List
Power Adapter	MFR: Roku M/N:W15-024N2A Input: AC 100-120V,0.8A 50-60Hz Output: DC 12V, 2.0A

Bluetooth Working Frequency of Each Channel: (For V3.0)							
Channel	Frequency	Channel	Frequency	Channel	Frequency	Channel	Frequency
00	2402 MHz	01	2403 MHz	02	2404 MHz	03	2405 MHz
04	2406 MHz	05	2407 MHz	06	2408 MHz	07	2409 MHz
08	2410 MHz	09	2411 MHz	10	2412 MHz	11	2413 MHz
12	2414 MHz	13	2415 MHz	14	2416 MHz	15	2417 MHz
16	2418 MHz	17	2419 MHz	18	2420 MHz	19	2421 MHz
20	2422 MHz	21	2423 MHz	22	2424 MHz	23	2425 MHz
24	2426 MHz	25	2427 MHz	26	2428 MHz	27	2429 MHz
28	2430 MHz	29	2431 MHz	30	2432 MHz	31	2433 MHz
32	2434 MHz	33	2435 MHz	34	2436 MHz	35	2437 MHz
36	2438 MHz	37	2439 MHz	38	2440 MHz	39	2441 MHz
40	2442 MHz	41	2443 MHz	42	2444 MHz	43	2445 MHz
44	2446 MHz	45	2447 MHz	46	2448 MHz	47	2449 MHz
48	2450 MHz	49	2451 MHz	50	2452 MHz	51	2453 MHz
52	2454 MHz	53	2455 MHz	54	2456 MHz	55	2457 MHz
56	2458 MHz	57	2459 MHz	58	2460 MHz	59	2461 MHz
60	2462 MHz	61	2463 MHz	62	2464 MHz	63	2465 MHz
64	2466 MHz	65	2467 MHz	66	2468 MHz	67	2469 MHz
68	2470 MHz	69	2471 MHz	70	2472 MHz	71	2473 MHz
72	2474 MHz	73	2475 MHz	74	2476 MHz	75	2477 MHz
76	2478 MHz	77	2479 MHz	78	2480 MHz	N/A	N/A

Bluetooth Working Frequency of Each Channel: (For V4.0)							
Channel	Frequency	Channel	Frequency	Channel	Frequency	Channel	Frequency
00	2402 MHz	01	2404 MHz	02	2406 MHz	03	2408 MHz
04	2410 MHz	05	2412 MHz	06	2414 MHz	07	2416 MHz
08	2418 MHz	09	2420 MHz	10	2422 MHz	11	2424 MHz
12	2426 MHz	13	2428 MHz	14	2430 MHz	15	2432 MHz
16	2434 MHz	17	2436 MHz	18	2438 MHz	19	2440 MHz
20	2442 MHz	21	2444 MHz	22	2446 MHz	23	2448 MHz
24	2450 MHz	25	2452 MHz	26	2454 MHz	27	2456 MHz
28	2458 MHz	29	2460 MHz	30	2462 MHz	31	2464 MHz
32	2466 MHz	33	2468 MHz	34	2470 MHz	35	2472 MHz
36	2474 MHz	37	2476 MHz	38	2478 MHz	39	2480 MHz

Bluetooth Antenna List

Antenna No.	Manufacturer	Model No.	Peak Gain
Antenna	Airgain	N2410CM3	0.7dBi

1.1. Mode of Operation

QuieTek has verified the construction and function in typical operation. All the test modes were carried out with the EUT in normal operation, which was shown in this test report and defined as:

Test Mode
Mode 1: Transmitter-1Mbps(GFSK_DH5)
Mode 2: Transmitter-2Mbps(Pi/4 DQPSK_DH5)
Mode 3: Transmitter-3Mbps(8DPSK_DH5)

Note:

1. Regards to the frequency band operation: the lowest, middle and highest frequency of channel were selected to perform the test, then shown on this report.
2. For portable device, radiated spurious emission was verified over X, Y, Z axis, and shown the worst case on this report.

1.2. Tested System Details

The types for all equipments, plus descriptions of all cables used in the tested system (including inserted cards) are:

Product	Manufacturer	Model No.	Serial No.	Power Cord
1 Notebook	Asus	N80V	8BN0AS226971468	N/A

1.3. Configuration of Tested System

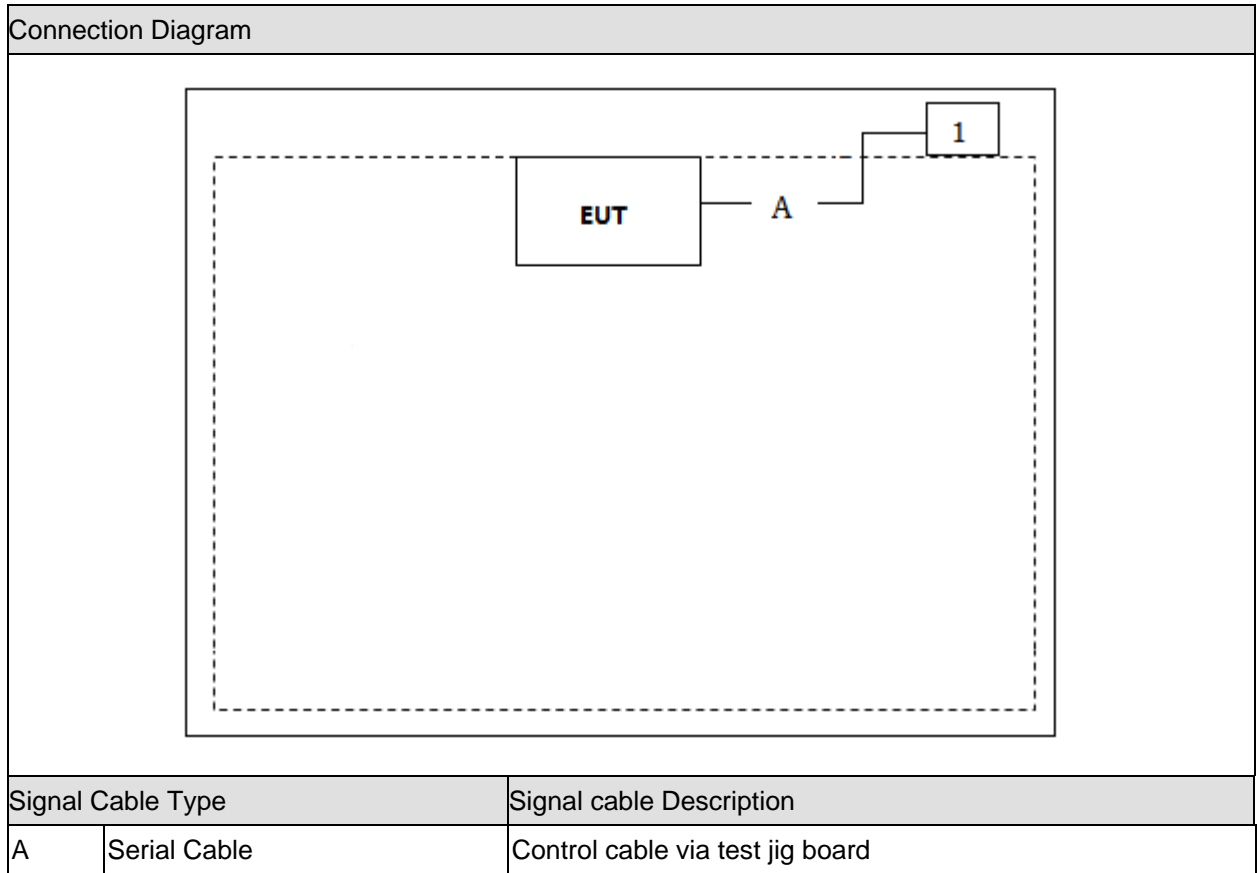

1.4. EUT Exercise Software

1	Setup the EUT and simulators as shown on above.
2	Turn on the power of all equipment.
3	Input the RF commands, and set the test mode and channel, then press OK to start continue Transmit.

2. Technical Test

2.1. Summary of Test Result

No deviations from the test standards

Deviations from the test standards as below description:

Performed Test Item	Normative References	Test Performed	Deviation
Conducted Emission	FCC CFR Title 47 Part 15 Subpart C: 2015 Section 15.207	Yes	No
Radiated Emission	FCC CFR Title 47 Part 15 Subpart C: 2015 Section 15.209	Yes	No
20dB Bandwidth	FCC CFR Title 47 Part 15 Subpart C: 2015 Section 15.247(a)(1)	Yes	No
Carrier Frequency Separation	FCC CFR Title 47 Part 15 Subpart C: 2015 Section 15.247(a)(1)	Yes	No
Number of Hopping Frequencies	FCC CFR Title 47 Part 15 Subpart C: 2015 Section 15.247(a)(1)(iii)	Yes	No
Time of Occupancy (Dwell Time)	FCC CFR Title 47 Part 15 Subpart C: 2015 Section 15.247(a)(1)(iii)	Yes	No
Peak Output Power	FCC CFR Title 47 Part 15 Subpart C: 2015 Section 15.247(b)(1)	Yes	No
Band-edge Compliance of RF Conducted Emissions	FCC CFR Title 47 Part 15 Subpart C: 2015 Section 15.215(c), 15.247(d)	Yes	No
Spurious RF Conducted Emissions	FCC CFR Title 47 Part 15 Subpart C: 2015 15.247(d)	Yes	No
Radiated Emission Band Edge	FCC CFR Title 47 Part 15 Subpart C: 2015 15.247(d)	Yes	No

Performed Test Item	Normative References	Test Performed	Deviation
Conducted Emission	RSS-Gen Issue 4 November 2014 Section 8.8	Yes	No
Radiated Emission	RSS-247 Issue 1 May 2015 Section 5.5	Yes	No
RF Antenna Conducted Spurious	RSS-247 Issue 1 May 2015 Section 5.5	Yes	No
Radiated Emission Band Edge	RSS-Gen Issue 4 November 2014 Section 8.10	Yes	No
Occupied Bandwidth	RSS-Gen Issue 4 November 2014 Section 6.6 RSS-247 Issue 1 May 2015 Section 5.2	Yes	No
Power Output	RSS-247 Issue 1 May 2015 Section 5.4	Yes	No

2.2. Test Environment

Items	Required (IEC 68-1)	Actual
Temperature (°C)	15-35	21
Humidity (%RH)	25-75	50
Barometric pressure (mbar)	860-1060	950-1000

3. Conducted Emission

3.1. Test Equipment

Conducted Emission / TR-1

Instrument	Manufacturer	Type No.	Serial No.	Cal. Due Date
EMI Test Receiver	R&S	ESCI	100726	2016.03.10
Two-Line V-Network	R&S	ENV216	100043	2016.03.10
Two-Line V-Network	R&S	ENV216	100044	2016.09.16
50ohm Coaxial Switch	Anritsu	MP59B	6200464462	2016.03.01
50ohm Termination	SHX	TF2	07081401	2016.09.16
Temperature/Humidity Meter	zhicheng	ZC1-2	TR1-TH	2016.01.07

Note: All equipments are calibrated with traceable calibrations. Each calibration is traceable to the national or international standards.

3.2. Test Setup

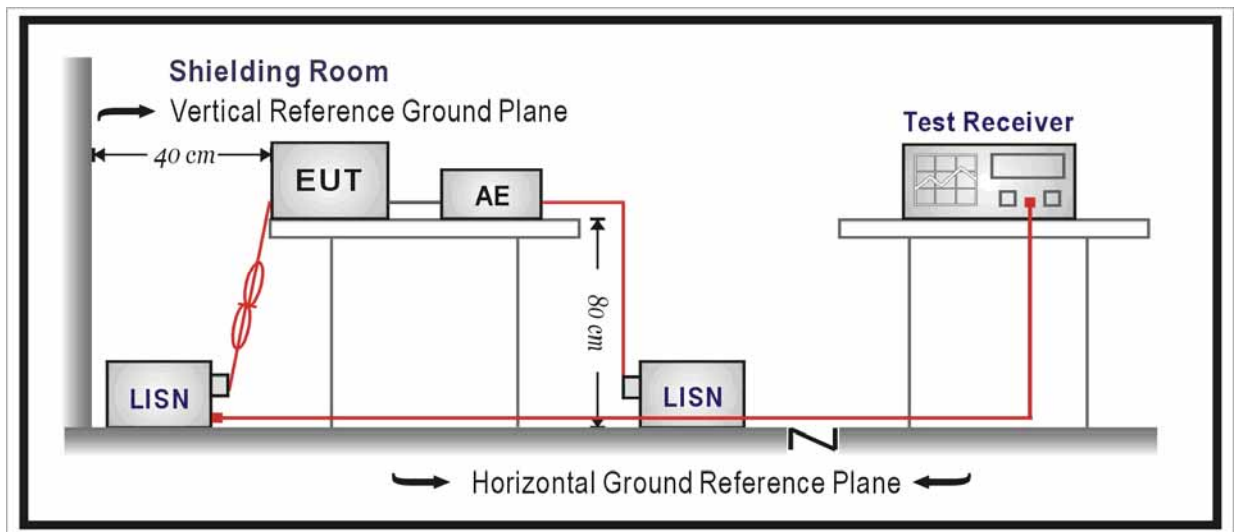

3.3. Limit

FCC Part 15 Subpart C Paragraph 15.207 Limits		
Frequency (MHz)	QP (dBuV)	AV (dBuV)
0.15 - 0.50	66 - 56	56 - 46
0.50 - 5.0	56	46
5.0 - 30	60	50

Note 1: The lower limit shall apply at the transition frequencies.

Note 2: The limit decreases linearly with the logarithm of the frequency in the range 0.15 MHz to 0.5 MHz.

3.4. Test Procedure

According to FCC ANSI C63.4: 2014 & ANSI C63.10: 2013.

The EUT was placed on a platform of nominal size, 1 m by 1.5 m, raised 80 cm above the conducting ground plane. The vertical conducting plane was located 40 cm to the rear of the EUT. All other surfaces of EUT were at least 80 cm from any other grounded conducting surface. The EUT and simulators are connected to the main power through a line impedance stabilization network (LISN). The LISN provides a 50 ohm /50uH coupling impedance for the measuring equipment. The peripheral devices are also connected to the main power through a LISN. (Please refer to the block diagram of the test setup and photographs)

Each current-carrying conductor of the EUT power cord, except the ground (safety) conductor, was individually connected through a LISN to the input power source.

The excess length of the power cord between the EUT and the LISN receptacle were folded back and forth at the center of the lead to form a bundle not exceeding 40 cm in length.

Conducted emissions were investigated over the frequency range from 0.15MHz to 30MHz using a receiver bandwidth of 9kHz.

3.5. Uncertainty

The measurement uncertainty is defined as ± 2.02 dB

3.6. Test Result

Engineer: Scott	
Site: TR5	Time: 2015/09/06
Limit: FCC_Part15.207_CE_AC Power_ClassB	Margin: 0
Probe: ENV216_101044(0.009-30MHz)	Polarity: Neutral
EUT: IP-STB	Power: AC 120V/60Hz
Note: Mode 1 802.11b CH2412	

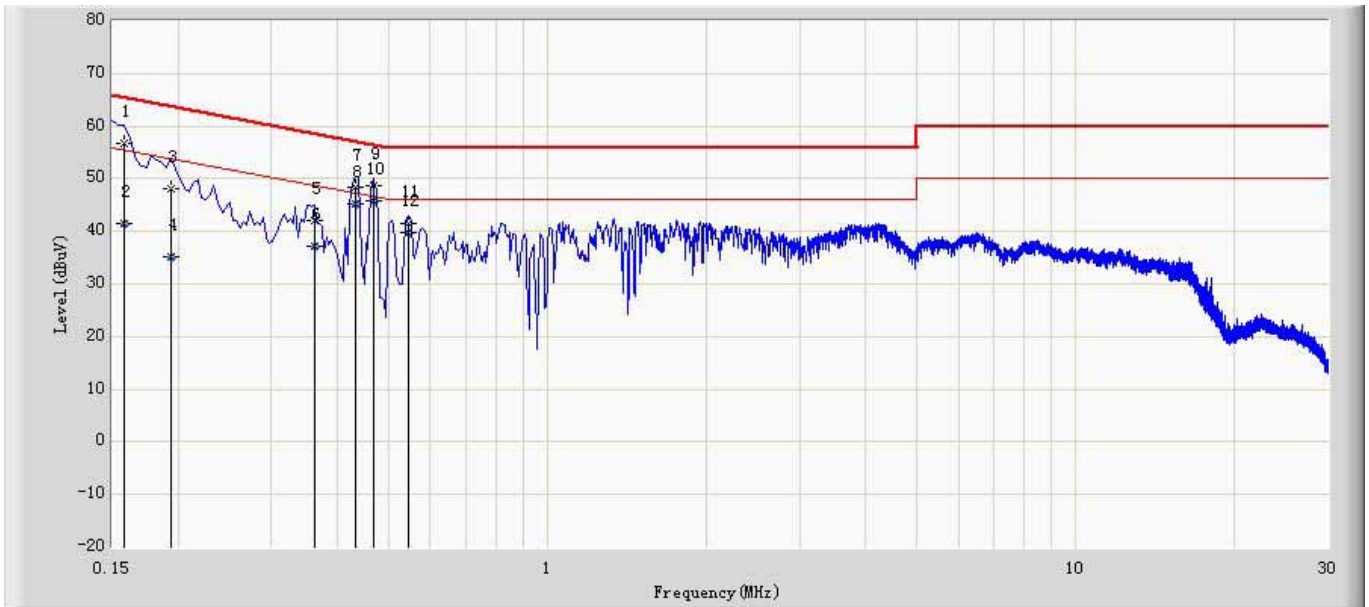

No	Mark	Frequency (MHz)	Measure Level (dBuV)	Reading Level (dBuV)	Over Limit (dB)	Limit (dBuV)	Factor (dB)	Type
1		0.158	56.595	46.864	-8.973	65.568	9.731	QP
2		0.158	41.633	31.902	-13.935	55.568	9.731	AV
3		0.194	48.112	38.392	-15.752	63.864	9.720	QP
4		0.194	35.304	25.584	-18.560	53.864	9.720	AV
5		0.362	42.001	32.299	-16.681	58.682	9.702	QP
6		0.362	37.128	27.426	-11.554	48.682	9.702	AV
7		0.434	48.437	38.729	-8.739	57.176	9.708	QP
8		0.434	45.099	35.391	-2.077	47.176	9.708	AV
9		0.470	48.617	38.917	-7.897	56.514	9.700	QP
10	*	0.470	45.717	36.017	-0.797	46.514	9.700	AV
11		0.546	41.569	31.869	-14.431	56.000	9.700	QP
12		0.546	39.771	30.071	-6.229	46.000	9.700	AV

Engineer: Scott	
Site: TR5	Time: 2015/09/06
Limit: FCC_Part15.207_CE_AC Power_ClassB	Margin: 0
Probe: ENV216_101044(0.009-30MHz)	Polarity: Line
EUT: IP-STB	Power: AC 120V/60Hz
Note: Mode 1 802.11b CH2412	

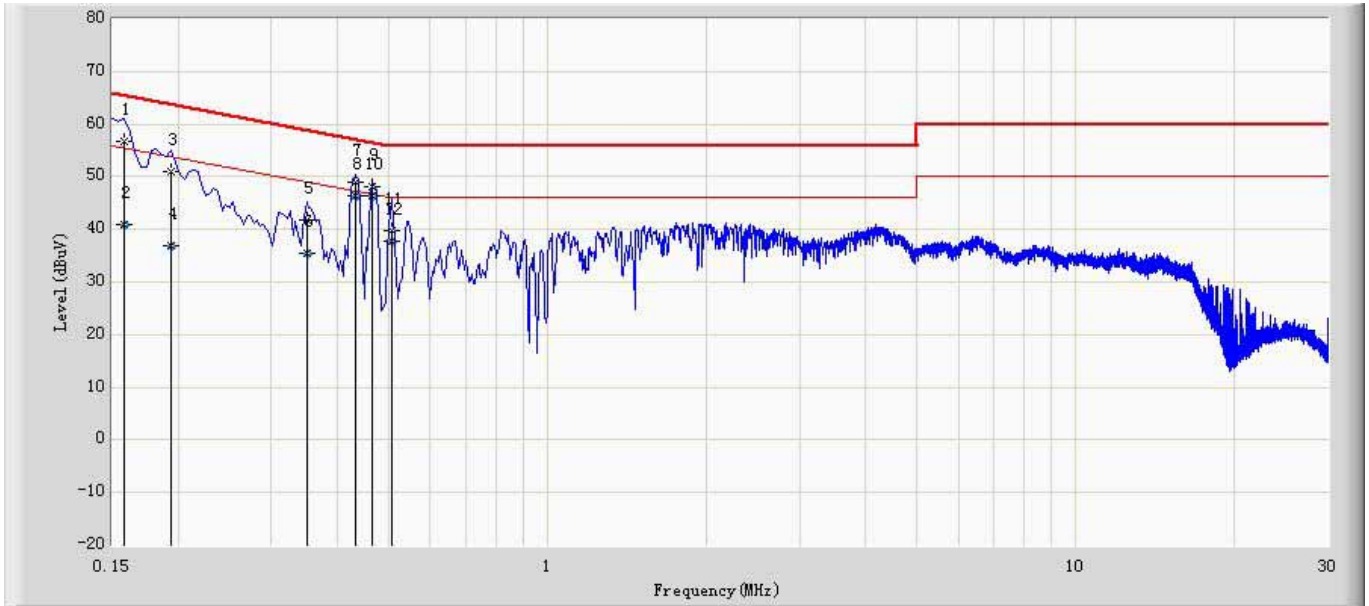

No	Mark	Frequency (MHz)	Measure Level (dBuV)	Reading Level (dBuV)	Over Limit (dB)	Limit (dBuV)	Factor (dB)	Type
1		0.158	56.680	46.949	-8.888	65.568	9.731	QP
2		0.158	41.040	31.309	-14.528	55.568	9.731	AV
3		0.194	51.012	41.302	-12.852	63.864	9.710	QP
4		0.194	36.908	27.198	-16.956	53.864	9.710	AV
5		0.350	41.734	32.034	-17.228	58.962	9.700	QP
6		0.350	35.446	25.746	-13.516	48.962	9.700	AV
7		0.434	48.850	39.150	-8.326	57.176	9.700	QP
8		0.434	46.447	36.747	-0.729	47.176	9.700	AV
9		0.466	48.106	38.406	-8.479	56.585	9.700	QP
10	*	0.466	46.275	36.575	-0.310	46.585	9.700	AV
11		0.506	39.911	30.211	-16.089	56.000	9.700	QP
12		0.506	37.782	28.082	-8.218	46.000	9.700	AV

Note: All the test modes are pretested and mode 1 802.11b mode was found to be the worst mode, so the data of this test mode was recorded.

4. Radiated Emission

4.1. Test Equipment

Radiated Emission / AC-2

Instrument	Manufacturer	Type No.	Serial No.	Cal. Due Date
EMI Test Receiver	R&S	ESCI	100573	2016.03.10
Loop Antenna	R&S	HFH2-Z2	833799/003	2015.11.25
Bilog Antenna	Teseq GmbH	CBL6112D	27611	2015.10.10
Coaxial Cable	Huber+Suhner	SUCOFLEX 106	AC2-C	2016.03.01
Temperature/Humidity Meter	Zhicheng	ZC1-2	AC2-TH	2016.01.07

Radiated Emission / AC-5

Instrument	Manufacturer	Type No.	Serial No.	Cal. Due Date
Spectrum Analyzer	Agilent	N9010A	MY48030494	2016.03.10
Preamplifier	Miteq	NSP1800-25	1364185	2016.05.03
Preamplifier	Quietek	AP-040G	CHM-0906001	2016.05.03
Bilog Antenna	Teseq GmbH	CBL6112D	27612	2015.10.15
Broad-Band Horn Antenna	Schwarzbeck	BBHA9120D	499	2016.06.08
Broad-Band Horn Antenna	Schwarzbeck	BBHA9170	294	2016.04.10
Coaxial Cable	Huber+Suhner	SUCOFLEX 106	AC5-C1	2016.03.01
Coaxial Cable	Huber+Suhner	SUCOFLEX 106	AC5-C2	2016.03.01
Coaxial Cable	Huber+Suhner	SUCOFLEX 102	AC5-C3	2016.03.01
Temperature/Humidity Meter	Zhicheng	ZC1-2	AC5-TH	2016.01.07

4.2. Test Setup

Below 30MHz Test Setup:

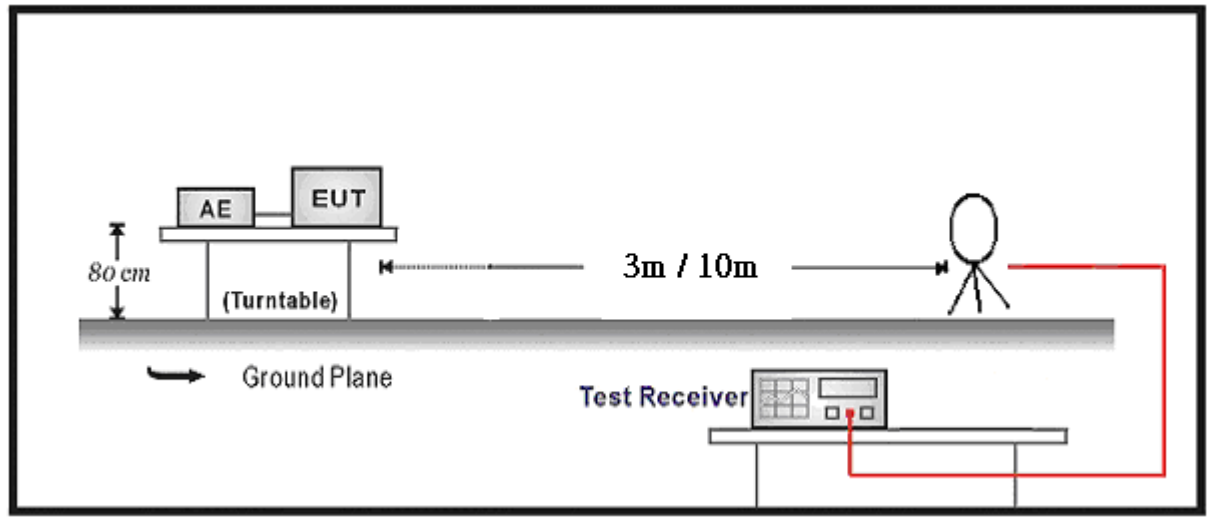

Below 1GHz Test Setup:

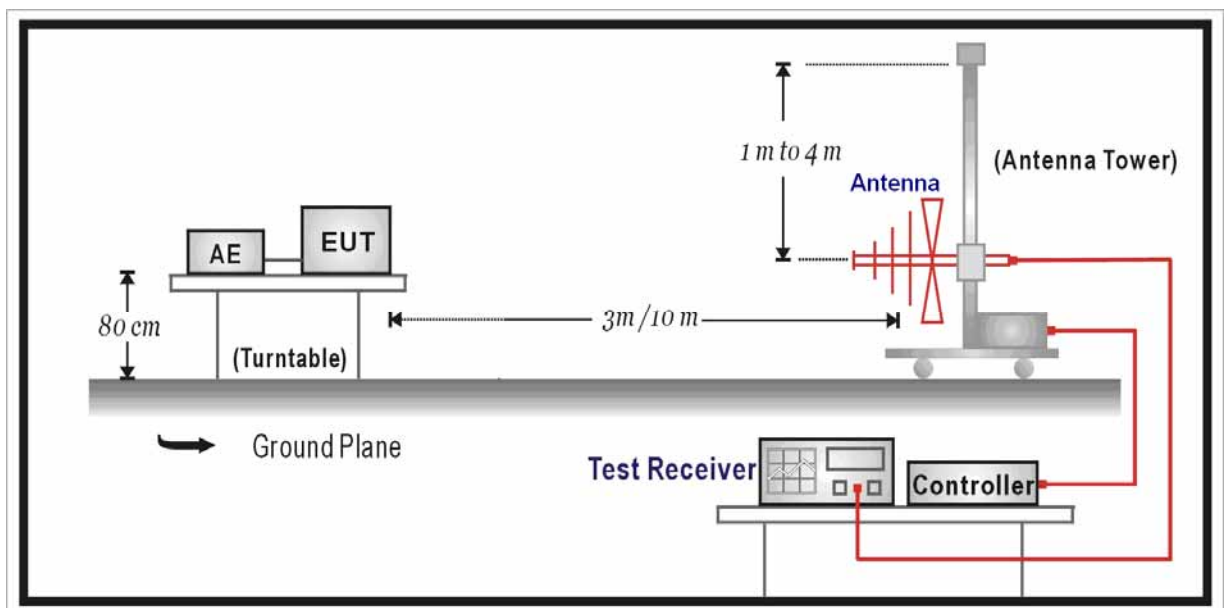

Above 1GHz Test Setup:

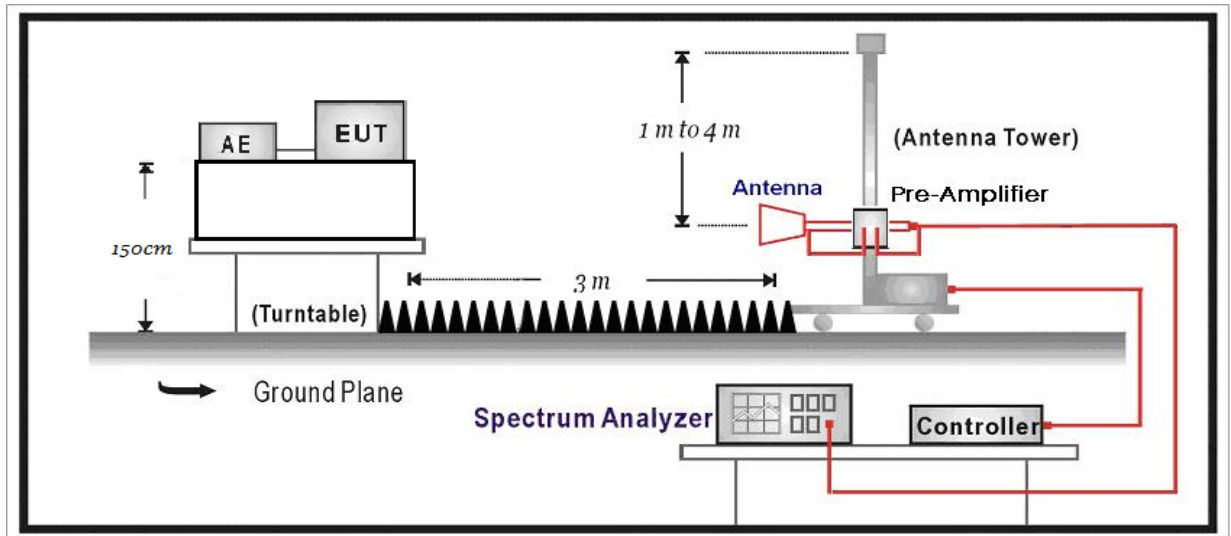

4.3. Limit

FCC Part 15 Subpart C Paragraph 15.209		
Frequency (MHz)	Distance (m)	Level (dBuV/m)
30 - 88	3	40
88 - 216	3	43.5
216 - 960	3	46
Above 960	3	54

Note 1: The lower limit shall apply at the transition frequency.

Note 2: Distance refers to the distance in meters between the measuring instrument antenna and the closed point of any part of the device or system.

Note 3: E field strength (dBuV/m) = 20 log E field strength (uV/m)

4.4. Test Procedure

According to ANSI C63.4: 2014; ANSI C63.10: 2013.

The EUT is placed on a turn table which is 1.5 meter for above 1G and 0.8 meter for below 1G above ground. The turn table is rotated 360 degrees to determine the position of the maximum emission level. The EUT was positioned such that the distance from antenna to the EUT was 3 meters.

The antenna is scanned from 1 meter to 4 meters to find out the maximum emission level.

This is repeated for both horizontal and vertical polarization of the antenna. In order to find the maximum emission, all of the interface cables were manipulated according to ANSI C63.4: 2014 on radiated measurement.

The resolution bandwidth below 1GHz setting on the field strength meter is 120 kHz and above 1GHz is 1MHz.

The frequency range from 30MHz to 10th harmonic is checked.

Note: When doing emission measurement above 1GHz, the horn antenna will be bended down a little (as horn antenna has the narrow beamwidth) in order to keeping the antenna in the “cone of radiation” of EUT. The 3dB beamwidth is 60~10 degrees for H-plane and 90~10 degrees for E-plane.

4.5. Uncertainty

The measurement uncertainty above 1G is defined as ± 3.9 dB
below 1G is defined as ± 3.8 dB

4.6. Test Result

All of the test result shown indicates the worst case, and spectrum analyzer parameters setting as shown below:

Peak detector: RBW = 1MHz, VBW = 3MHz, sweep time = 200ms;

Average detector: RBW = 1MHz, VBW = 10Hz, sweep time = auto.

Measure Level = Reading Level + Cable Loss + Antenna Factor – Preamplifier Gain

Mode 1: Transmitter-1Mbps(GFSK_DH5)

CH	Antenna	Frequency (MHz)	Reading Level (dBuV/m)	Factor (dB)	Measure Level (dBuV/m)	Limit (dBuV/m)	Margin (dB)	Detector
0	H	4804.0	48.1	-6.6	41.5	54(Note3)	-12.5	PK
	V	4804.0	48.3	-6.6	41.6	54(Note3)	-12.4	PK
	H	7206.0	46.3	-2.9	43.4	54(Note3)	-10.6	PK
	V	7206.0	46.3	-2.9	43.4	54(Note3)	-10.6	PK
	H	9608.0	44.4	0.9	45.4	54(Note3)	-8.6	PK
	V	9608.0	44.1	0.9	45.1	54(Note3)	-8.9	PK
39	H	4882.0	48.3	-6.6	41.7	54(Note3)	-12.3	PK
	V	4882.0	47.7	-6.6	41.1	54(Note3)	-12.9	PK
	H	7323.0	47.7	-2.7	45.0	54(Note3)	-9.0	PK
	V	7323.0	47.2	-2.7	44.5	54(Note3)	-9.5	PK
	H	9764.0	43.8	1.3	45.2	54(Note3)	-8.8	PK
	V	9764.0	43.9	1.3	45.2	54(Note3)	-8.8	PK
78	H	4960.0	48.8	-6.3	42.5	54(Note3)	-11.5	PK
	V	4960.0	48.2	-6.3	41.9	54(Note3)	-12.1	PK
	H	7440.0	46.3	-2.6	43.7	54(Note3)	-10.3	PK
	V	7440.0	46.6	-2.6	43.9	54(Note3)	-10.1	PK
	H	9920.0	44.3	0.8	45.1	54(Note3)	-8.9	PK
	V	9920.0	44.1	0.8	44.9	54(Note3)	-9.1	PK

Note: 1. Measure Level = Reading Level + Factor.

2. The test frequency range, 9kHz~30MHz, 18GHz~25GHz, both of the worst case are at least 6dB below the limits, therefore no data appear in the report.
3. This limit applies for using average detector, if the test result on peak is lower than average limit, then average measurement needn't be performed.

Mode 2: Transmitter-2Mbps(Pi/4 DQPSK _DH5)

CH	Antenna	Frequency (MHz)	Reading Level (dBuV/m)	Factor (dB)	Measure Level (dBuV/m)	Limit (dBuV/m)	Margin (dB)	Detector
0	H	4804.0	49.0	-6.6	42.3	54(Note3)	-11.7	PK
	V	4804.0	50.0	-6.6	43.3	54(Note3)	-10.7	PK
	H	7206.0	46.2	-2.9	43.3	54(Note3)	-10.7	PK
	V	7206.0	46.4	-2.9	43.5	54(Note3)	-10.5	PK
	H	9608.0	44.9	0.9	45.8	54(Note3)	-8.2	PK
	V	9608.0	43.9	0.9	44.9	54(Note3)	-9.1	PK
39	H	4882.0	47.7	-6.6	41.1	54(Note3)	-12.9	PK
	V	4882.0	47.7	-6.6	41.1	54(Note3)	-12.9	PK
	H	7323.0	47.4	-2.7	44.7	54(Note3)	-9.3	PK
	V	7323.0	47.7	-2.7	45.0	54(Note3)	-9.0	PK
	H	9764.0	44.3	1.3	45.6	54(Note3)	-8.4	PK
	V	9764.0	45.7	1.3	47.1	54(Note3)	-6.9	PK
78	H	4960.0	48.9	-6.3	42.6	54(Note3)	-11.4	PK
	V	4960.0	48.3	-6.3	42.0	54(Note3)	-12.0	PK
	H	7440.0	46.4	-2.6	43.8	54(Note3)	-10.2	PK
	V	7440.0	46.5	-2.6	43.9	54(Note3)	-10.1	PK
	H	9920.0	44.8	0.8	45.6	54(Note3)	-8.4	PK
	V	9920.0	43.6	0.8	44.4	54(Note3)	-9.6	PK

Note: 1. Measure Level = Reading Level + Factor.

2. The test frequency range, 9kHz~30MHz, 18GHz~25GHz, both of the worst case are at least 6dB below the limits, therefore no data appear in the report.
3. This limit applies for using average detector, if the test result on peak is lower than average limit, then average measurement needn't be performed.

Mode 3: Transmitter-3Mbps(8DPSK_DH5)

CH	Antenna	Frequency (MHz)	Reading Level (dBuV/m)	Factor (dB)	Measure Level (dBuV/m)	Limit (dBuV/m)	Margin (dB)	Detector
0	H	4804.0	47.5	-6.6	40.8	54(Note3)	-13.2	PK
	V	4804.0	49.5	-6.6	42.9	54(Note3)	-11.1	PK
	H	7206.0	46.5	-2.9	43.6	54(Note3)	-10.4	PK
	V	7206.0	46.7	-2.9	43.8	54(Note3)	-10.2	PK
	H	9608.0	44.0	0.9	44.9	54(Note3)	-9.1	PK
	V	9608.0	43.6	0.9	44.5	54(Note3)	-9.5	PK
39	H	4882.0	48.0	-6.6	41.4	54(Note3)	-12.6	PK
	V	4882.0	48.8	-6.6	42.2	54(Note3)	-11.8	PK
	H	7323.0	47.9	-2.7	45.2	54(Note3)	-8.8	PK
	V	7323.0	47.3	-2.7	44.6	54(Note3)	-9.4	PK
	H	9764.0	44.1	1.3	45.4	54(Note3)	-8.6	PK
	V	9764.0	45.0	1.3	46.4	54(Note3)	-7.6	PK
78	H	4960.0	47.9	-6.3	41.6	54(Note3)	-12.4	PK
	V	4960.0	47.9	-6.3	41.6	54(Note3)	-12.4	PK
	H	7440.0	46.6	-2.6	44.0	54(Note3)	-10.0	PK
	V	7440.0	46.0	-2.6	43.4	54(Note3)	-10.6	PK
	H	9920.0	44.0	0.8	44.9	54(Note3)	-9.1	PK
	V	9920.0	44.5	0.8	45.4	54(Note3)	-8.6	PK

Note: 1. Measure Level = Reading Level + Factor.

2. The test frequency range, 9kHz~30MHz, 18GHz~25GHz, both of the worst case are at least 6dB below the limits, therefore no data appear in the report.
3. This limit applies for using average detector, if the test result on peak is lower than average limit, then average measurement needn't be performed.

The worst case of Radiated Emission below 1GHz:

Engineer: Scott	
Site: AC2	Time: 2015/09/06
Limit: FCC_Part15.209_RE(3m)_ClassB	Margin: 0
Probe: AC2_10M(30-1000M)20150408	Polarity: Horizontal
EUT: IP-STB	Power: AC 120V/60Hz
Note: Mode 1	

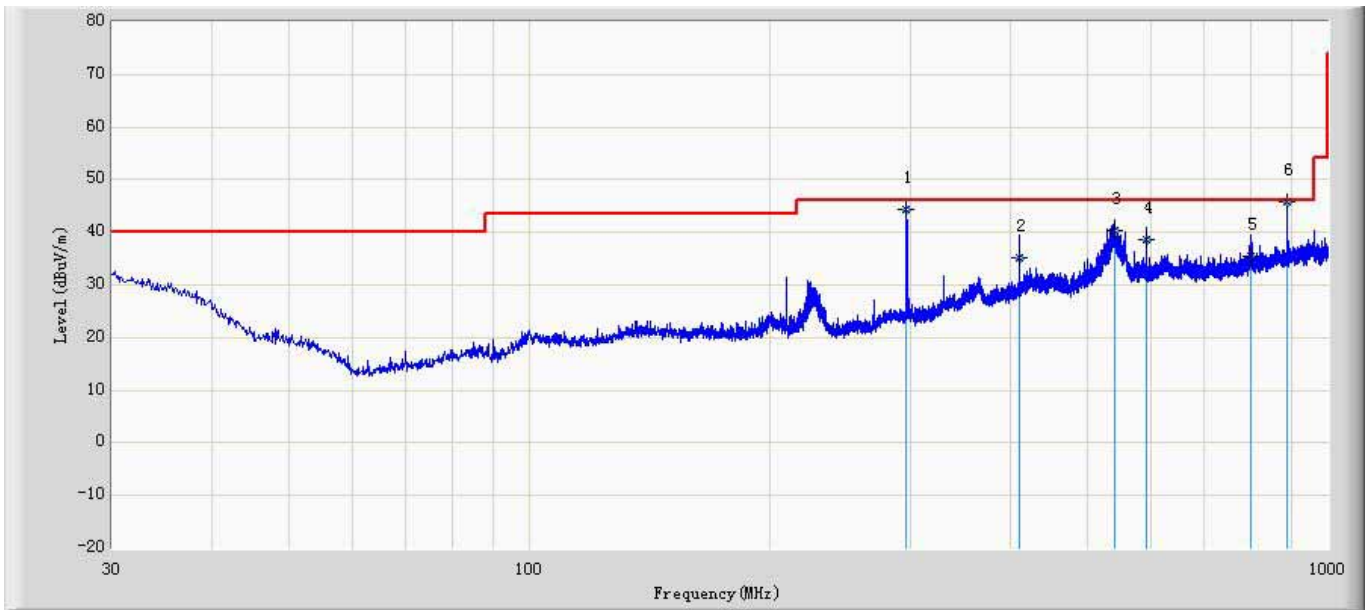

No	Mark	Frequency (MHz)	Measure Level (dBuV/m)	Reading Level (dBuV)	Over Limit (dB)	Limit (dBuV/m)	Factor (dB)	Type
1		296.728	44.474	29.322	-1.526	46.000	15.152	QP
2		410.236	35.100	16.655	-10.900	46.000	18.445	QP
3		540.236	40.300	19.014	-5.700	46.000	21.286	QP
4		593.125	38.500	16.840	-7.500	46.000	21.660	QP
5		800.236	35.600	12.488	-10.400	46.000	23.112	QP
6	*	890.241	45.936	22.175	-0.064	46.000	23.761	QP

Engineer: Scott	
Site: AC2	Time: 2015/09/06
Limit: FCC_Part15.209_RE(3m)_ClassB	Margin: 0
Probe: AC2_10M(30-1000M)20150408	Polarity: Vertical
EUT: IP-STB	Power: AC 120V/60Hz
Note: Mode 1	

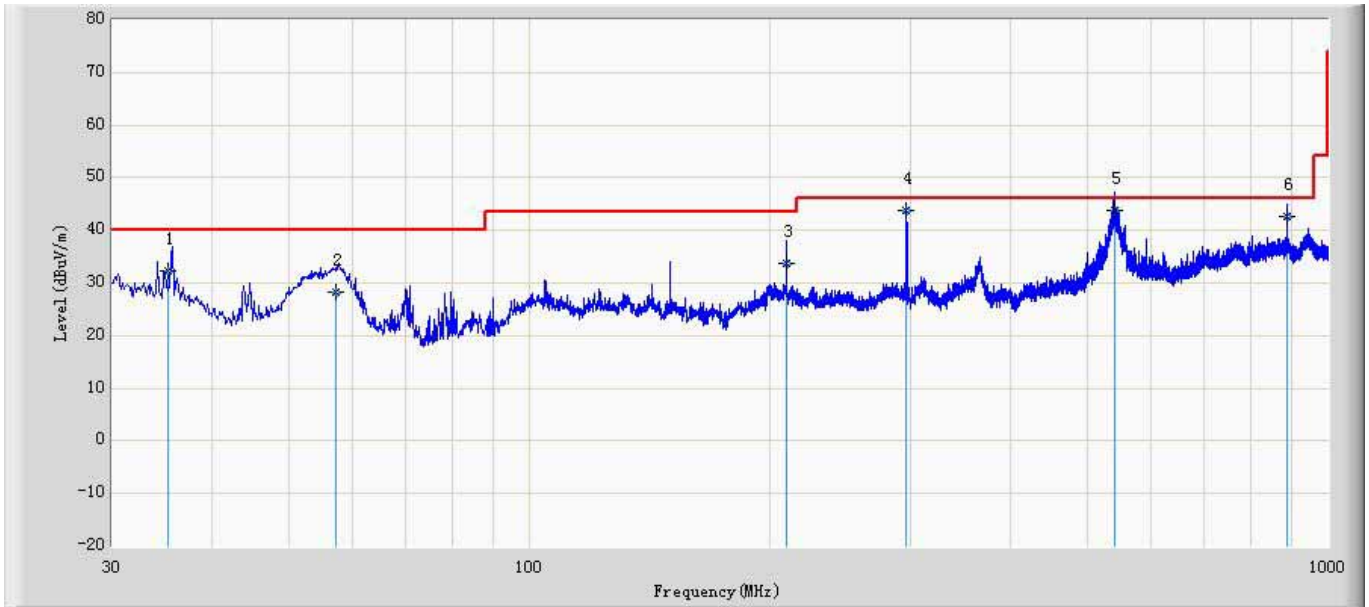

No	Mark	Frequency (MHz)	Measure Level (dBuV/m)	Reading Level (dBuV)	Over Limit (dB)	Limit (dBuV/m)	Factor (dB)	Type
1		35.236	32.200	15.793	-7.800	40.000	16.407	QP
2		57.125	28.200	20.391	-11.800	40.000	7.809	QP
3		209.526	33.600	22.814	-9.900	43.500	10.786	QP
4		296.729	43.679	28.527	-2.321	46.000	15.152	QP
5	*	540.754	43.890	22.586	-2.110	46.000	21.304	QP
6		890.202	42.752	18.991	-3.248	46.000	23.761	QP

5. 20dB Bandwidth

5.1 Test Equipment

20dB Bandwidth / TR8

Instrument	Manufacturer	Type No.	Serial No.	Cal. Due Date
Spectrum Analyzer	Agilent	N9010A	MY48030494	2016.03.10
Temperature/Humidity Meter	Zhicheng	ZC1-2	TR8-TH	2016.04.09

Note: All equipments are calibrated with traceable calibrations. Each calibration is traceable to the national or international standards.

5.2 Test Setup

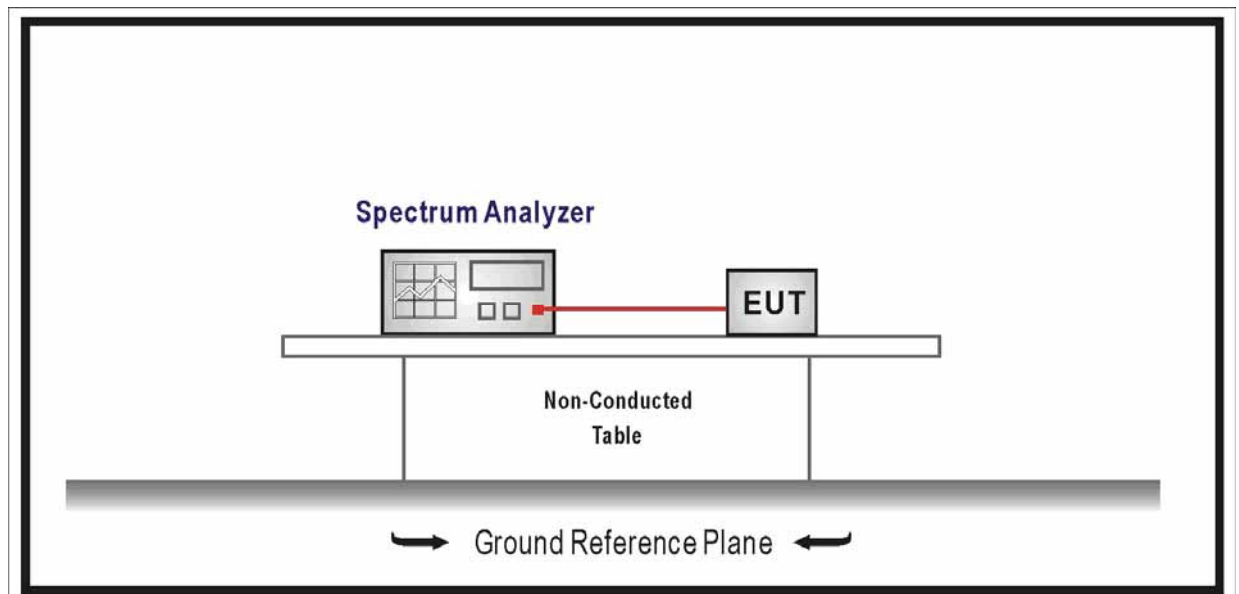

5.3 Limit

- For frequency hopping systems operating in 2400-2483.5 MHz band, no limitation.
- For frequency hopping systems operating in 902-928 MHz band, the maximum allowed 20 dB bandwidth of the hopping channel is 500 kHz.
- For frequency hopping systems operating in 5725-5850 MHz band, the maximum 20 dB bandwidth of the hopping channel is 1 MHz.

5.4 Test Procedure

According to ANSI C63.10: 2013& ANSI C63.4: 2014

Use the following spectrum analyzer settings:

Span = approximately 2 to 3 times the 20dB bandwidth, centered on a hopping channel

RBW \cong 1% of the 20dB bandwidth

VBW \cong RBW

Sweep = auto

Detector function = peak

Trace = max hold

The EUT should be transmitting at its maximum data rate. Allow the trace to stabilize.

Use the marker-to-peak function to set the marker to the peak of the emission. Use the marker-IP-STB function to measure 20 dB down one side of the emission. Reset the marker-IP-STB function, and move the marker to the other side of the emission, until it is (as close as possible to) even with the reference marker level. The marker-IP-STB reading at this point is the 20 dB bandwidth of the emission. If this value varies with different modes of operation (e.g., data rate, modulation format, etc.), repeat this test for each variation.

5.5 Uncertainty

The measurement uncertainty is defined as ± 1 kHz

5.6 Test Result

Product	:	IP-STB
Test Item	:	Occupied Bandwidth
Test Site	:	TR-8
Test Mode	:	Mode 1: Transmitter-1Mbps (GFSK_DH5)

Channel No.	Frequency (MHz)	20dB Bandwidth (kHz)	99% Bandwidth (kHz)
00	2402	885.5	867.96
39	2441	885.6	867.04
78	2480	885.3	865.98

Channel 00 (2402MHz)

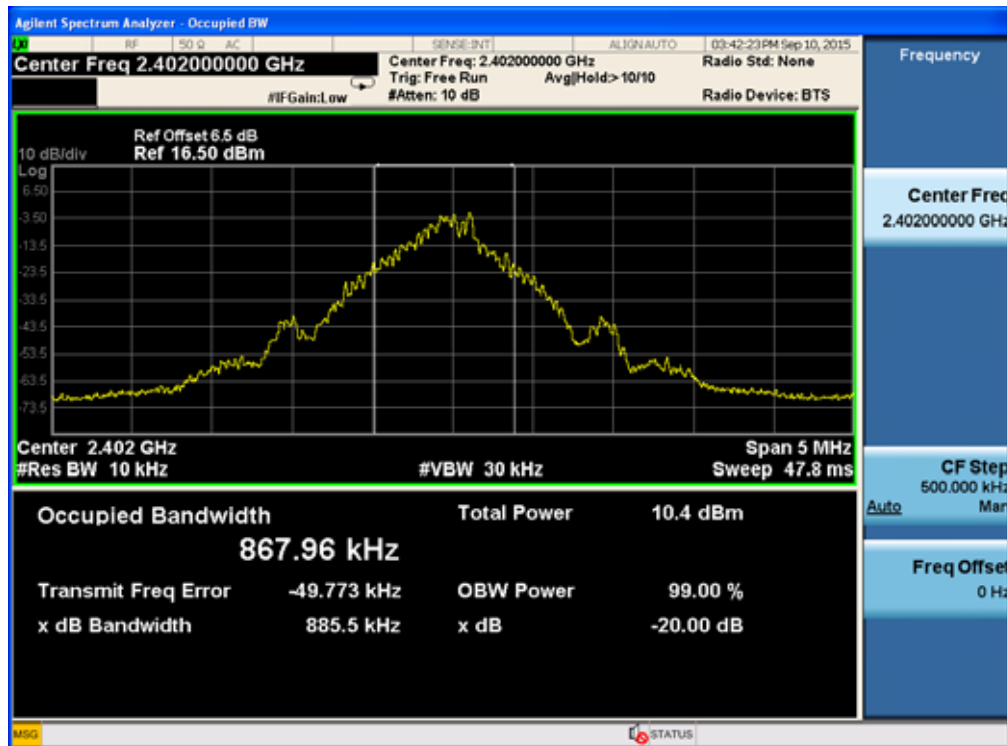

Channel 39 (2441MHz)

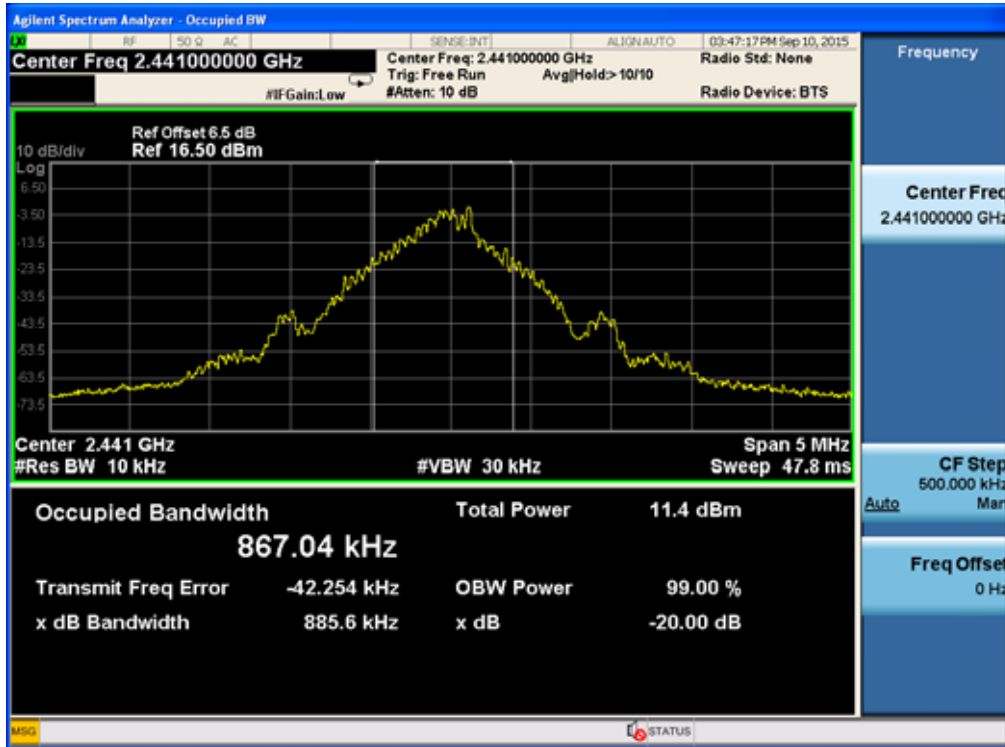

Channel 78 (2480MHz)

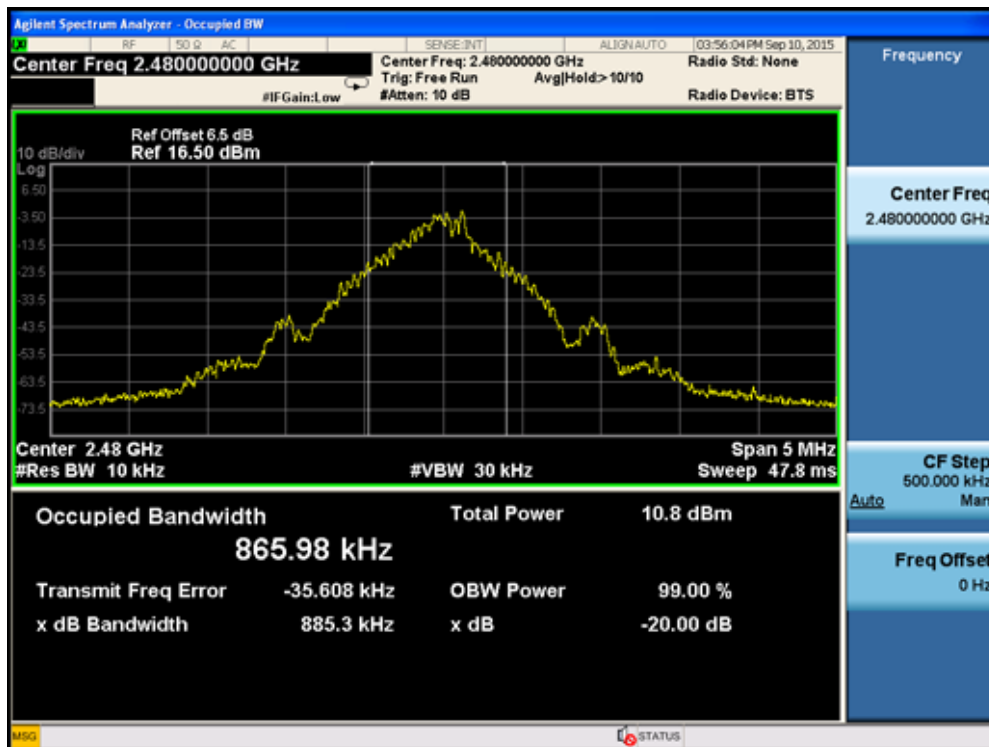

Product	:	IP-STB
Test Item	:	Occupied Bandwidth
Test Site	:	TR-8
Test Mode	:	Mode 2: Transmitter-2Mbps (Pi/4 DQPSK_DH5)

Channel No.	Frequency (MHz)	20dB Bandwidth (kHz)	99% Bandwidth (kHz)
00	2402	1326	1205.8
39	2441	1325	1208.2
78	2480	1325	1250.3

Channel 00 (2402MHz)

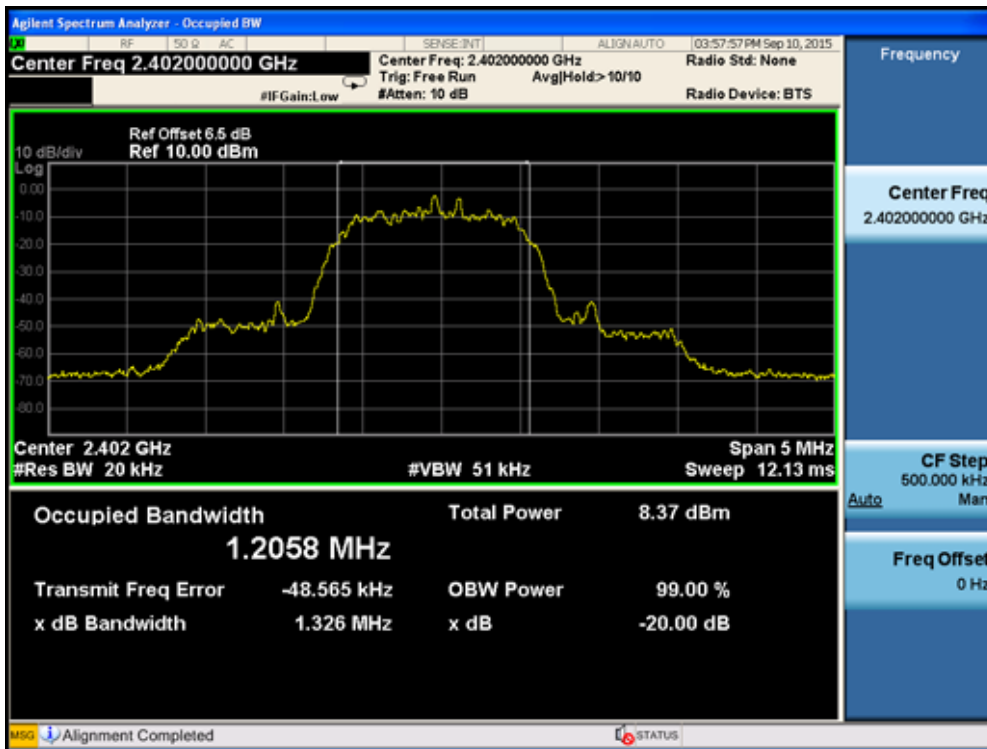

Channel 39 (2441MHz)



Channel 78 (2480MHz)



Product	:	IP-STB
Test Item	:	Occupied Bandwidth
Test Site	:	TR-8
Test Mode	:	Mode 3: Transmitter-3Mbps (8DPSK_DH5)

Channel No.	Frequency (MHz)	20dB Bandwidth (kHz)	99% Bandwidth (kHz)
00	2402	1278	1209.5
39	2441	1276	1210.0
78	2480	1275	1211.1

Channel 00 (2402MHz)

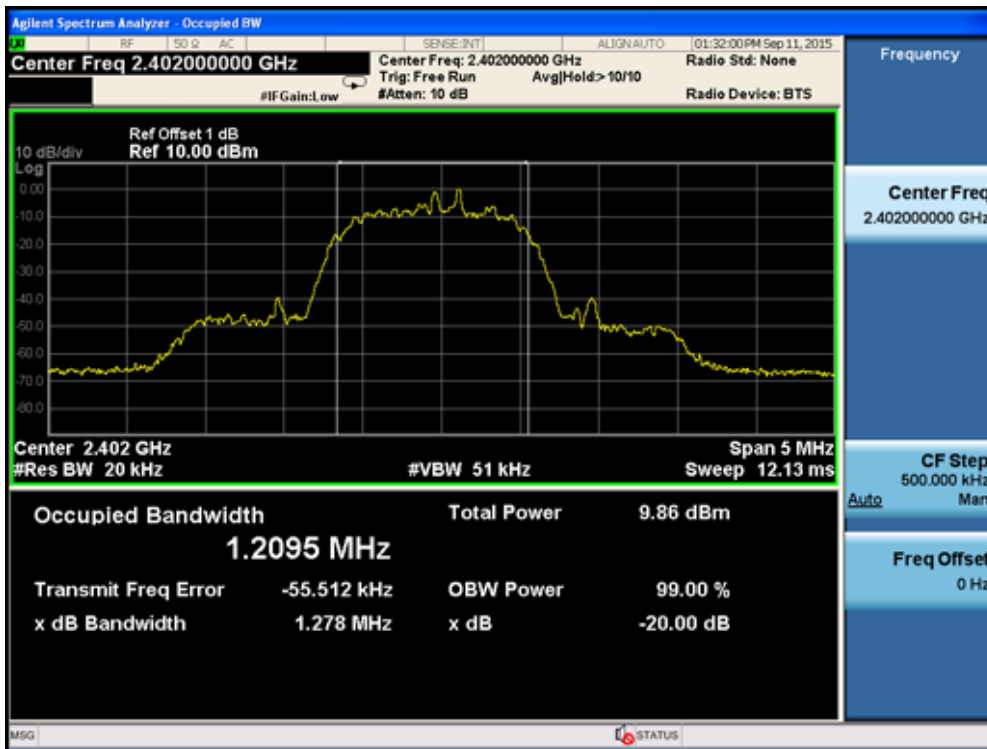

Channel 39 (2441MHz)

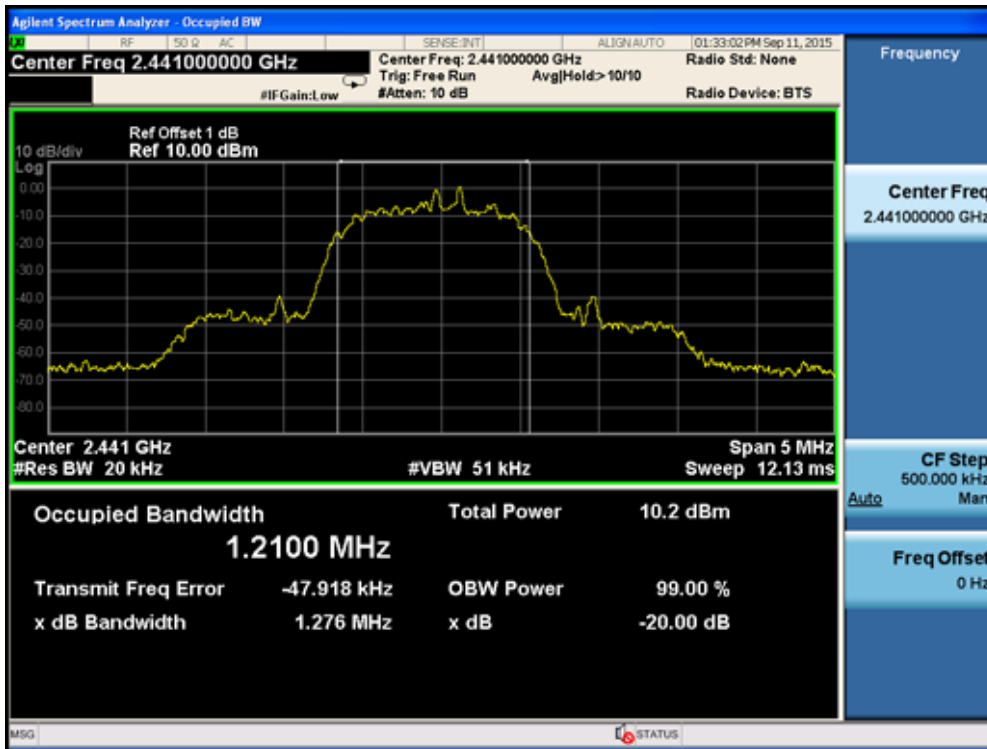

Channel 78 (2480MHz)



6. Carrier Frequency Separation

6.1. Test Equipment

Carrier Frequency Separation / TR-8

Instrument	Manufacturer	Type No.	Serial No.	Cal. Due Date
Spectrum Analyzer	Agilent	N9010A	MY48030494	2016.03.10
Temperature/Humidity Meter	Zhicheng	ZC1-2	TR8-TH	2016.04.09

Note: All equipments are calibrated with traceable calibrations. Each calibration is traceable to the national or international standards.

6.2. Test Setup

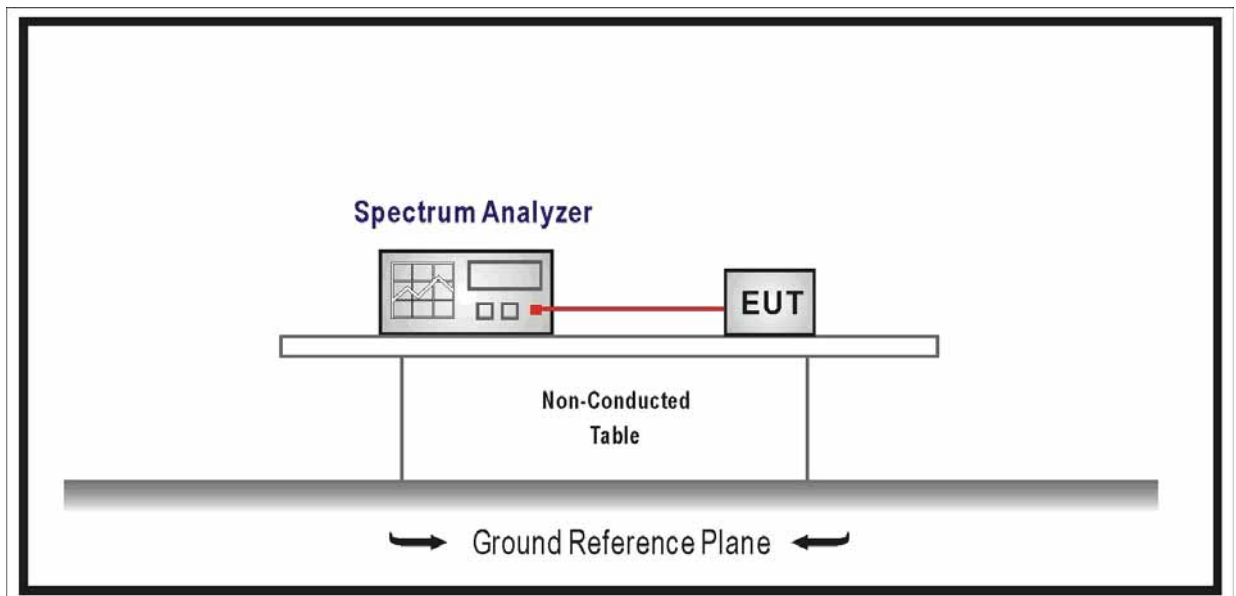

6.3. Limit

- Frequency hopping systems shall have hopping channel carrier frequencies separated by a minimum of 25 kHz or the 20 dB bandwidth of the hopping channel, whichever is greater. Alternatively, frequency hopping systems operating in the 2400-2483.5 MHz band may have hopping channel carrier frequencies that are separated by 25 kHz or two-thirds of the 20 dB bandwidth of the hopping channel, whichever is greater, provided the systems operate with an output power no greater than 125mW. The system shall hop to channel frequencies that are selected at the system hopping rate from a pseudorandomly ordered list of hopping frequencies. Each frequency must be used equally on the average by each transmitter. The system receivers shall have input bandwidths that match the hopping

channel bandwidths of their corresponding transmitters and shall shift frequencies in synchronization with the transmitted signals.

- For frequency hopping systems operating in the 902-928 MHz band: if the 20 dB bandwidth of the hopping channel is less than 250 kHz, the system shall use at least 50 hopping frequencies and the average time of occupancy on any frequency shall not be greater than 0.4 seconds within a 20 second period; If the 20 dB bandwidth of the hopping channel is 250 kHz or greater, the system shall use at least 25 hopping frequencies and the average time of occupancy on any frequency shall not be greater than 0.4 seconds within a 10 second period. The maximum allowed 20 dB bandwidth of the hopping channel is 500 kHz.
- Frequency hopping systems operating in the 5725-5850 MHz band shall use at least 75 hopping frequencies. The maximum 20 dB bandwidth of the hopping channel is 1 MHz. The average time of occupancy on any frequency shall not be greater than 0.4 seconds within a 30 second period.

6.4. Test Procedure

According to ANSI C63.10: 2013& ANSI C63.4: 2014

The EUT must have its hopping function enabled. Use the following spectrum analyzer settings:

Span = wide enough to capture the peaks of two adjacent channels

Resolution (or IF) Bandwidth (RBW) \geq 1% of the span

Video (or Average) Bandwidth VBW \geq RBW

Sweep = auto

Detector function = peak

Trace = max hold

Allow the trace to stabilize. Use the marker-IP-STB function to determine the separation between the peaks of the adjacent channels.

6.5. Uncertainty

The measurement uncertainty is defined as ± 1 kHz

6.6. Test Result

Product	:	IP-STB
Test Item	:	Carrier Frequency Separation
Test Site	:	TR-8
Test Mode	:	Mode 1: Transmitter-1Mbps (GFSK_DH5)

Channel No.	Frequency (MHz)	Carrier Frequency Separation (kHz)	Limit (kHz)	Result
00	2402	1000	>25 kHz or 2/3 of 20 dB BW	Pass
39	2441	1000	>25 kHz or 2/3 of 20 dB BW	Pass
78	2480	1000	>25 kHz or 2/3 of 20 dB BW	Pass

Channel 00 (2402MHz)

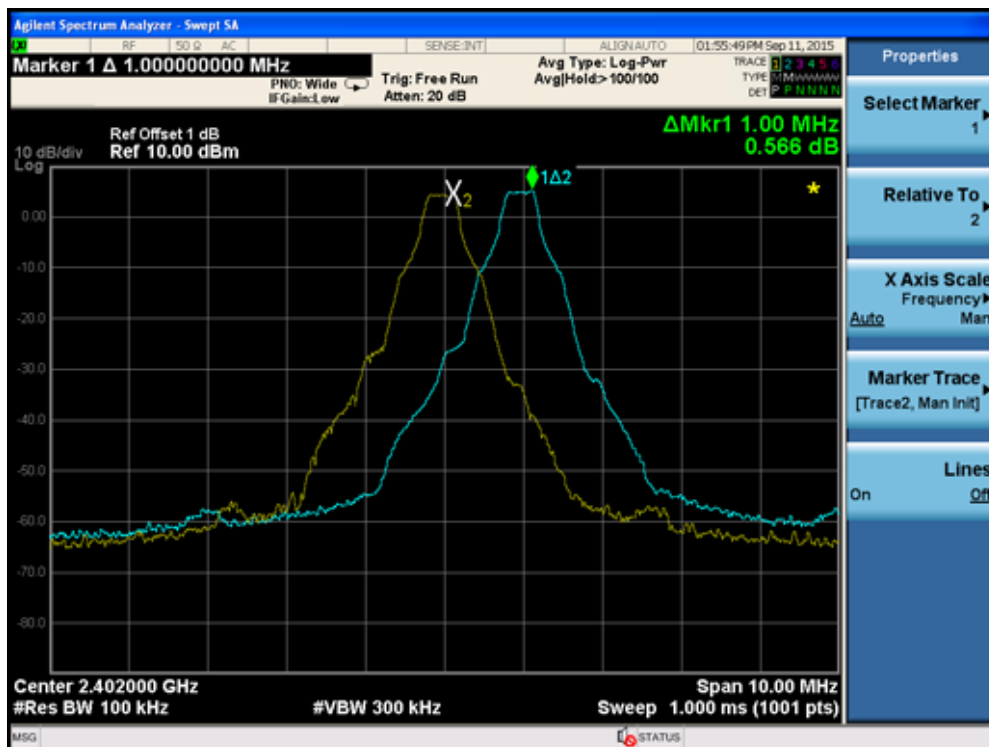

Channel 39 (2441MHz)

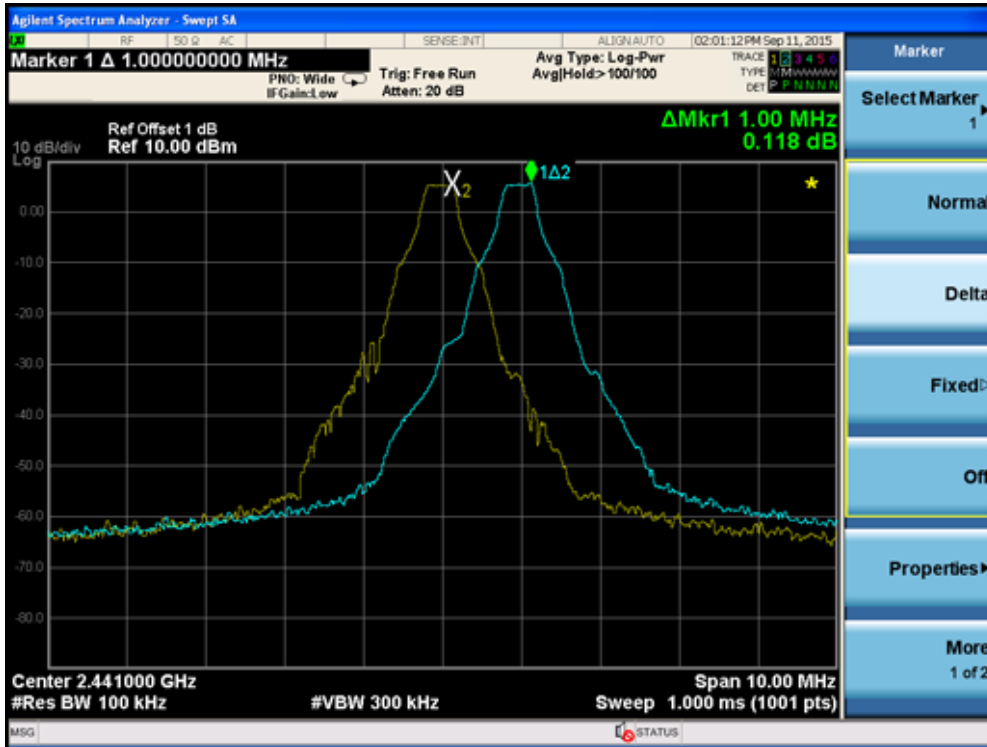

Channel 78 (2480MHz)

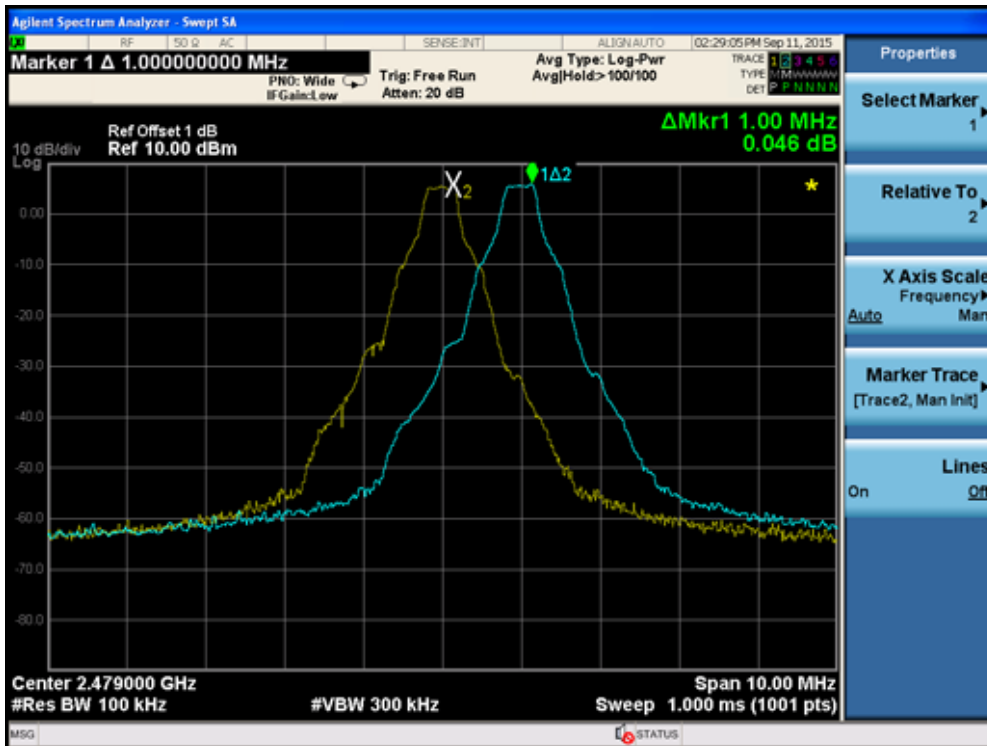

Product	: IP-STB
Test Item	: Carrier Frequency Separation
Test Site	: TR-8
Test Mode	: Mode 2: Transmitter-2Mbps (Pi/4 DQPSK_DH5)

Channel No.	Frequency (MHz)	Carrier Frequency Separation (kHz)	Limit (kHz)	Result
00	2402	1000	>25 kHz or 2/3 of 20 dB BW	Pass
39	2441	1000	>25 kHz or 2/3 of 20 dB BW	Pass
78	2480	1000	>25 kHz or 2/3 of 20 dB BW	Pass

Channel 00 (2402MHz)

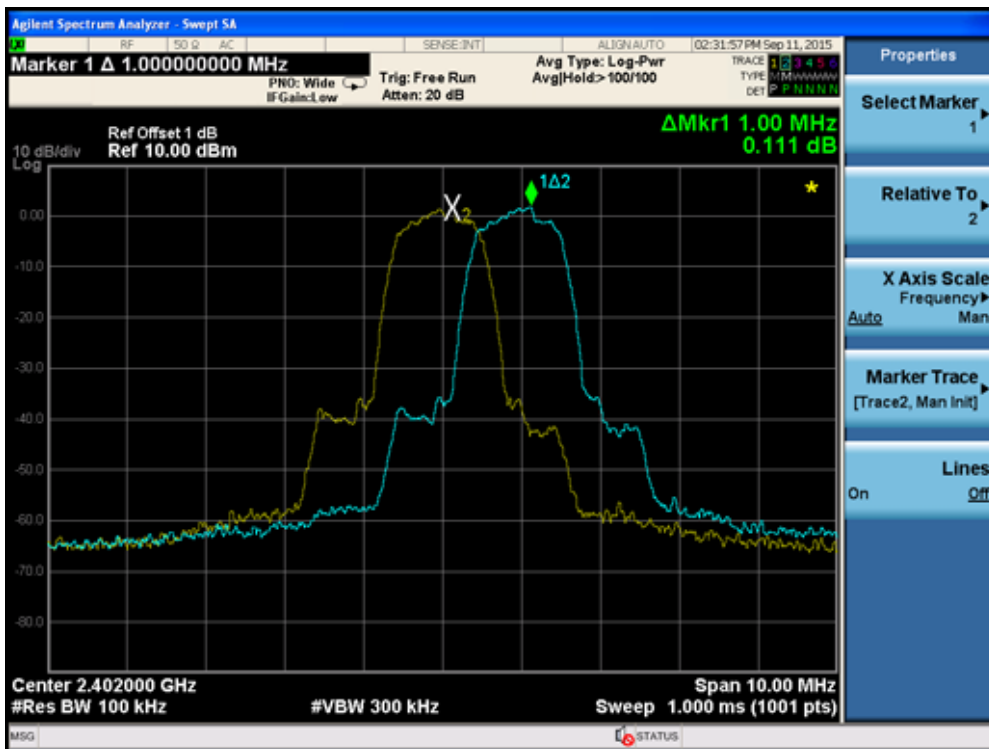

Channel 39 (2441MHz)

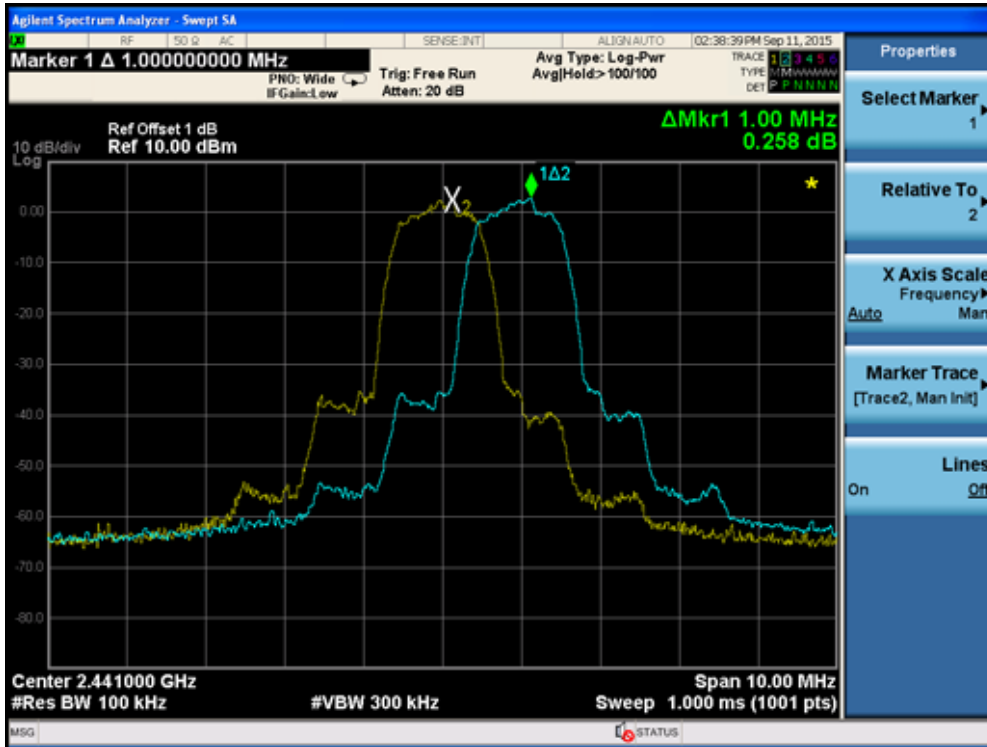

Channel 78 (2480MHz)

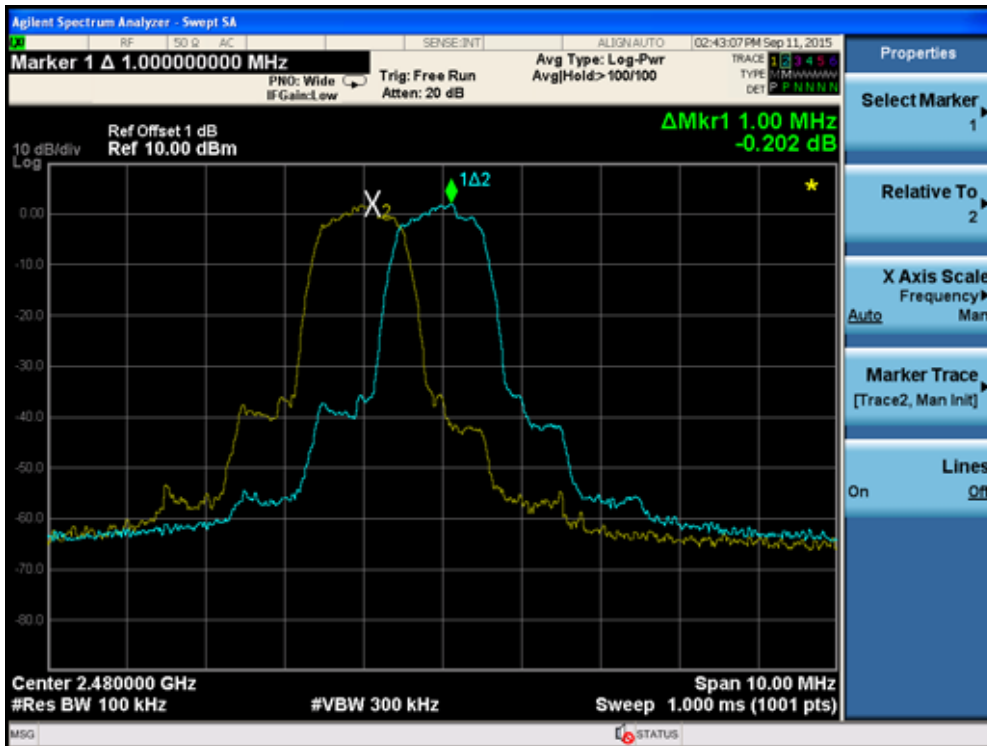

Product	: IP-STB
Test Item	: Carrier Frequency Separation
Test Site	: TR-8
Test Mode	: Mode 3: Transmitter-3Mbps (8DPSK_DH5)

Channel No.	Frequency (MHz)	Carrier Frequency Separation (kHz)	Limit (kHz)	Result
00	2402	1000	>25 kHz or 2/3 of 20 dB BW	Pass
39	2441	1000	>25 kHz or 2/3 of 20 dB BW	Pass
78	2480	1000	>25 kHz or 2/3 of 20 dB BW	Pass

Channel 00 (2402MHz)

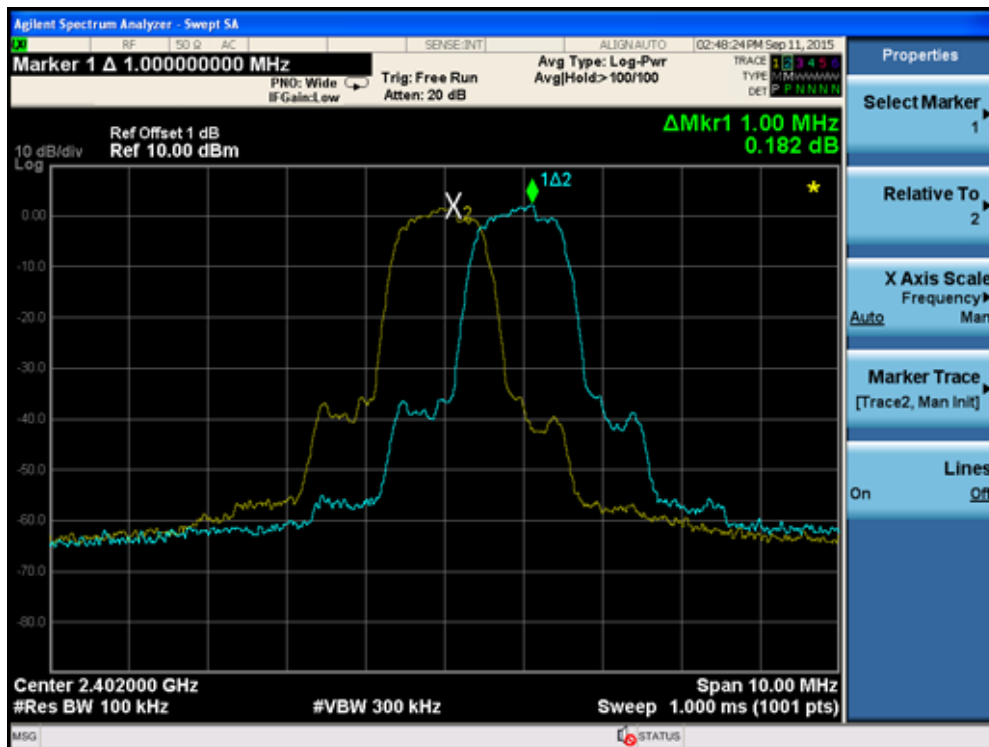

Channel 39 (2441MHz)

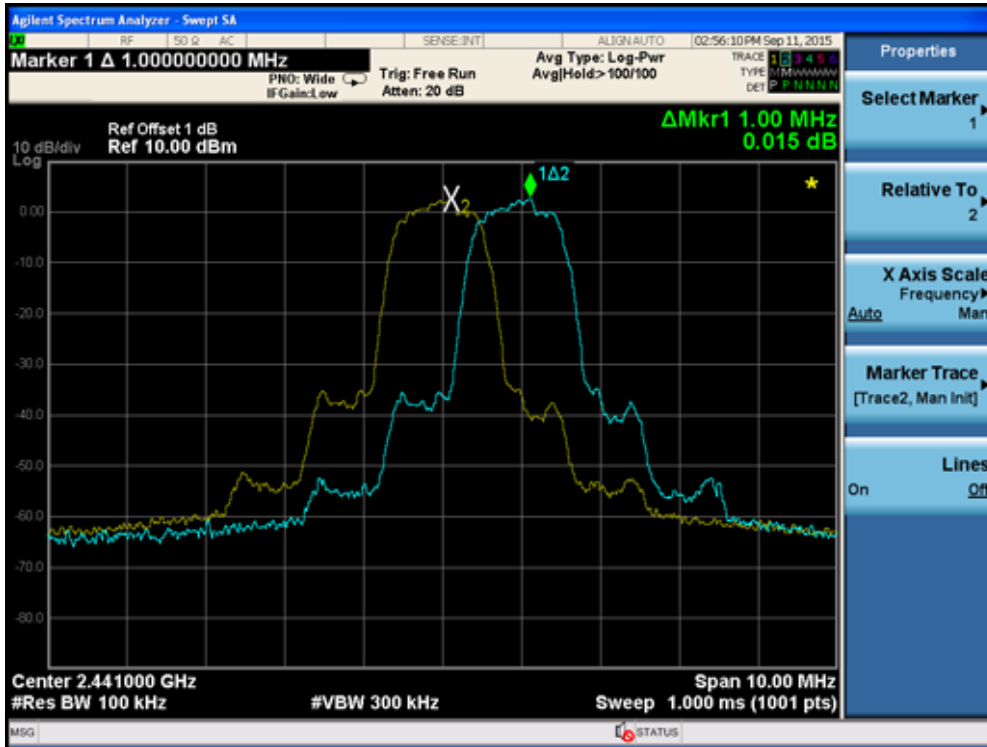

Channel 78 (2480MHz)

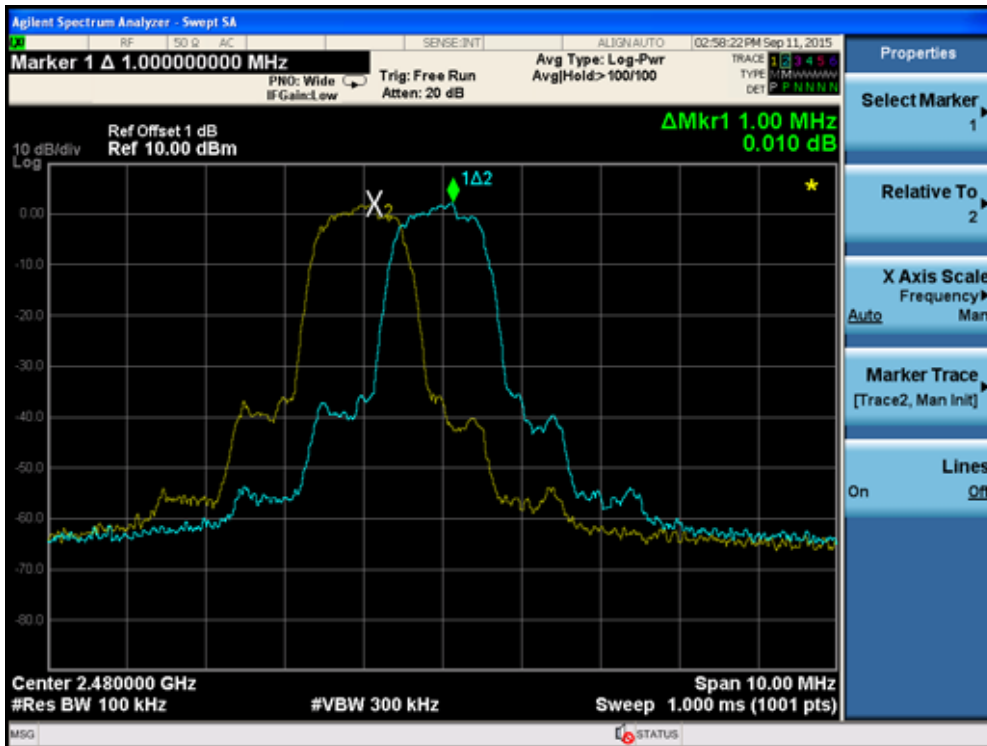

7. Number of Hopping Frequencies

7.1. Test Equipment

Number of Hopping Frequencies / TR-8

Instrument	Manufacturer	Type No.	Serial No.	Cal. Due Date
Spectrum Analyzer	Agilent	N9010A	MY48030494	2016.03.10
Temperature/Humidity Meter	Zhicheng	ZC1-2	TR8-TH	2016.04.09

Note: All equipments are calibrated with traceable calibrations. Each calibration is traceable to the national or international standards.

7.2. Test Setup

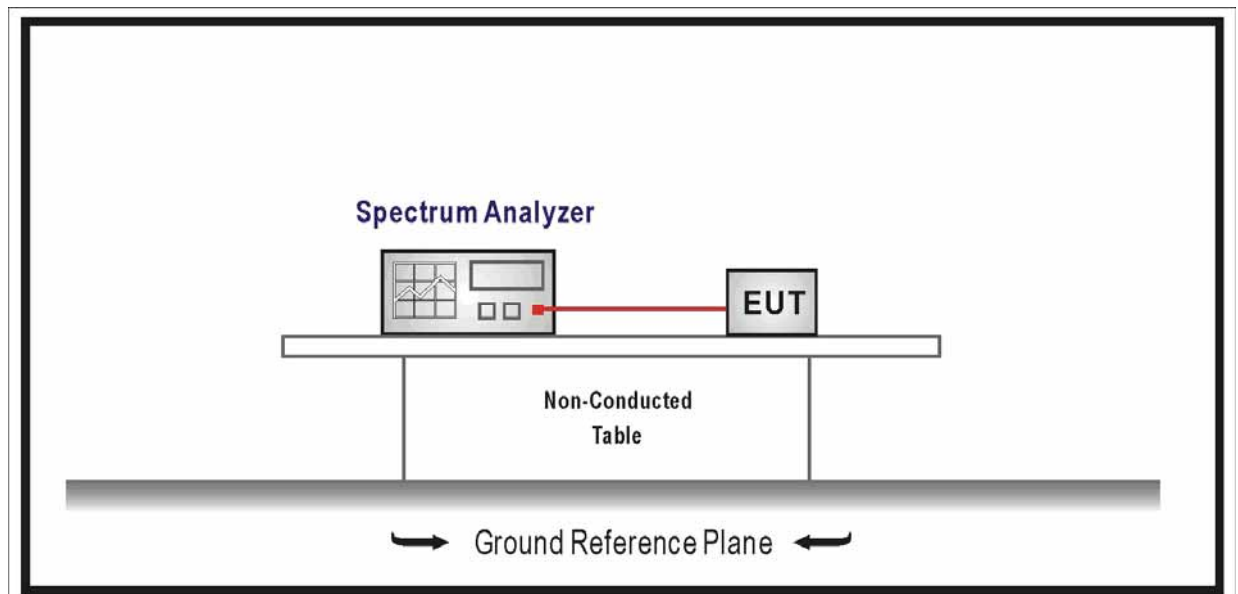

7.3. Limit

- For frequency hopping systems operating in the 2400-2483.5 MHz band shall use at least 15 hopping frequencies.
- For frequency hopping systems operating in 902-928 MHz band shall use at least 50 hopping frequencies.
- For frequency hopping systems operating in the 5725-5850 MHz band shall use at least 75 hopping frequencies.

7.4. Test Procedure

According to ANSI C63.10: 2013& ANSI C63.4: 2014

The EUT must have its hopping function enabled. Use the following spectrum analyzer settings:

Span = the frequency band of operation

RBW \cong 1% of the span

VBW \cong RBW

Sweep = auto

Detector function = peak

Trace = max hold

Allow the trace to stabilize. It may prove necessary to bread the span up to sections, in order to clearly show all of the hopping frequencies.

7.5. Uncertainty

The measurement uncertainty is defined as ± 1 kHz

7.6. Test Result

Product	:	IP-STB
Test Item	:	Number of Hopping Frequencies
Test Site	:	TR-8
Test Mode	:	Mode 1: Transmitter-1Mbps (GFSK_DH5)

Frequency Band (MHz)	Number of Hopping Frequencies	Limit	Result
2400 - 2483.5	79	>15	Pass

2400 - 2421 MHz

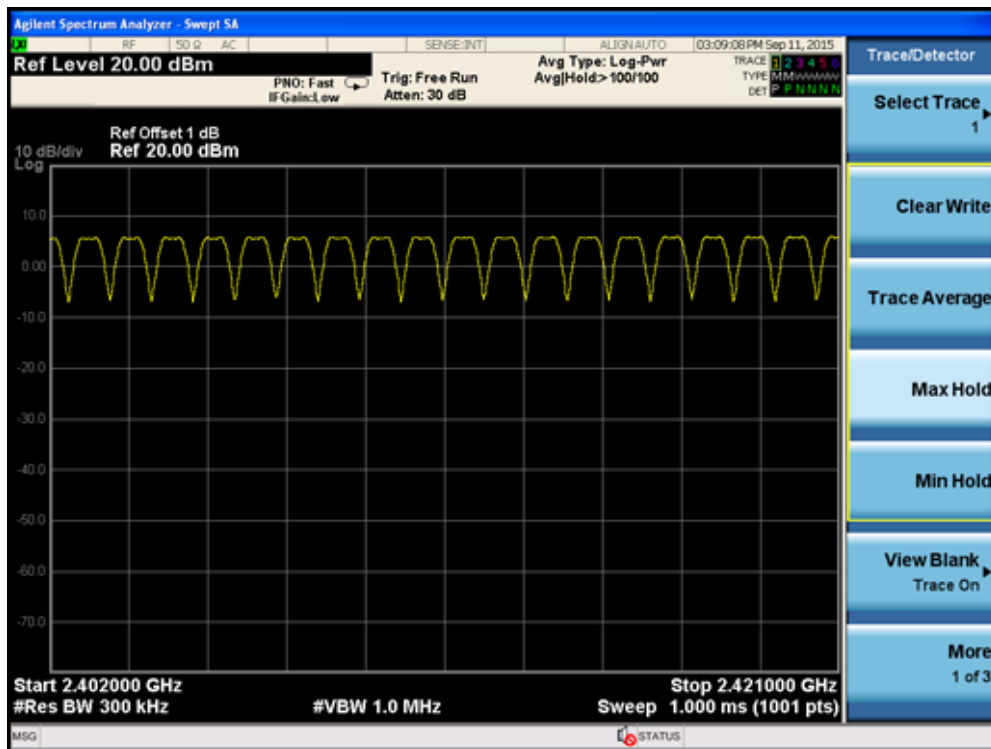

2422 - 2441 MHz

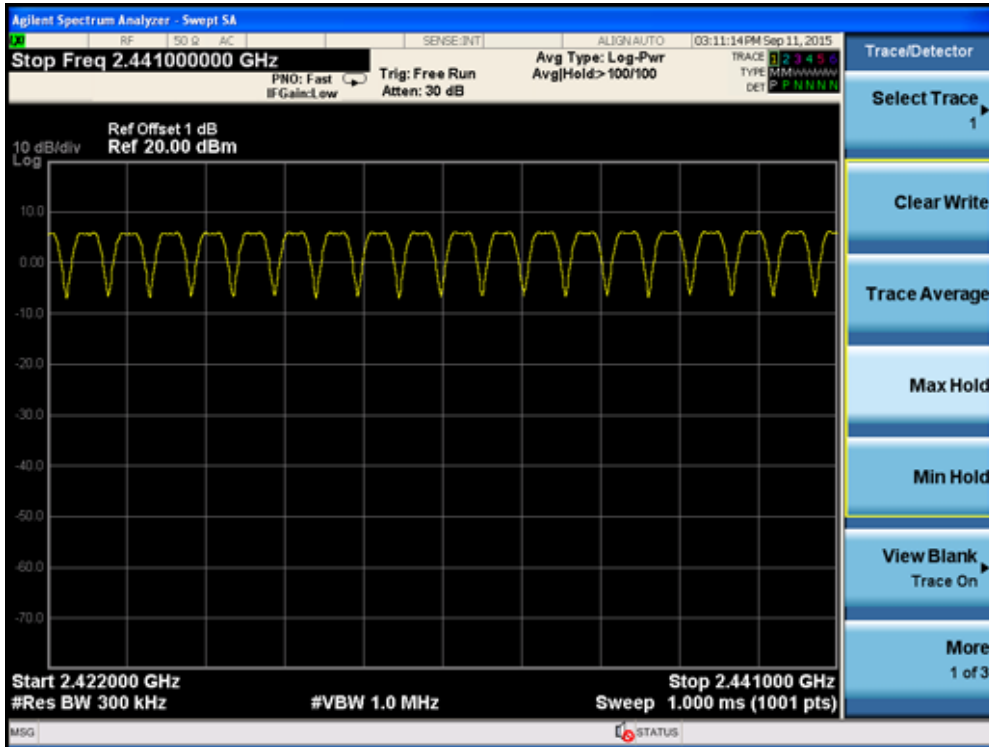

2442 - 2461 MHz

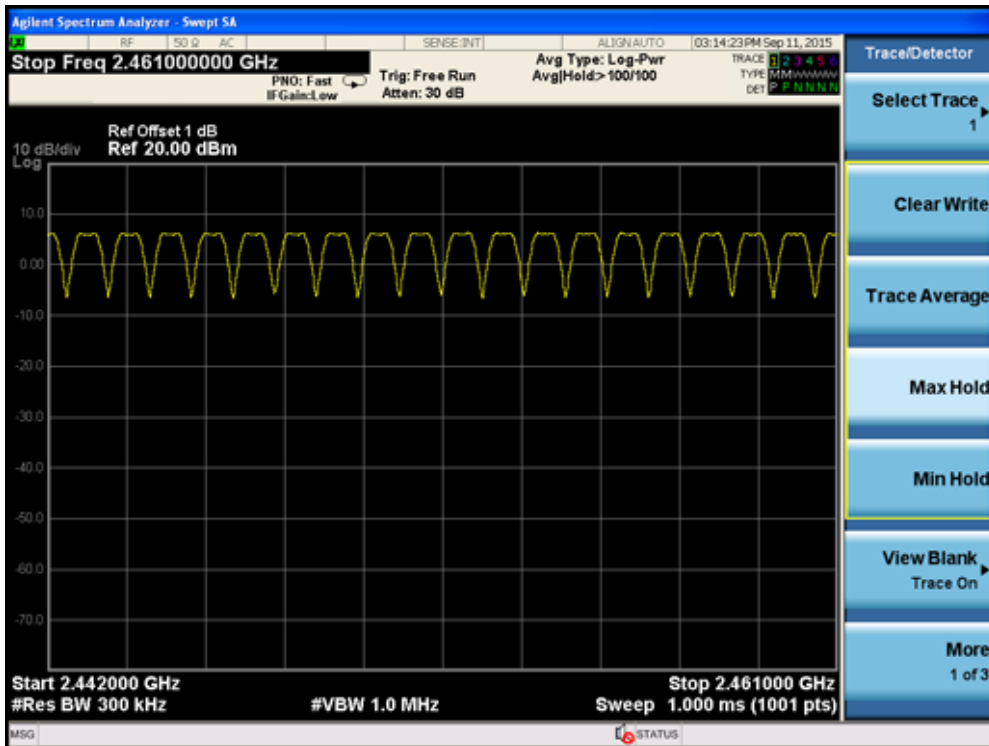

2462 - 2480 MHz

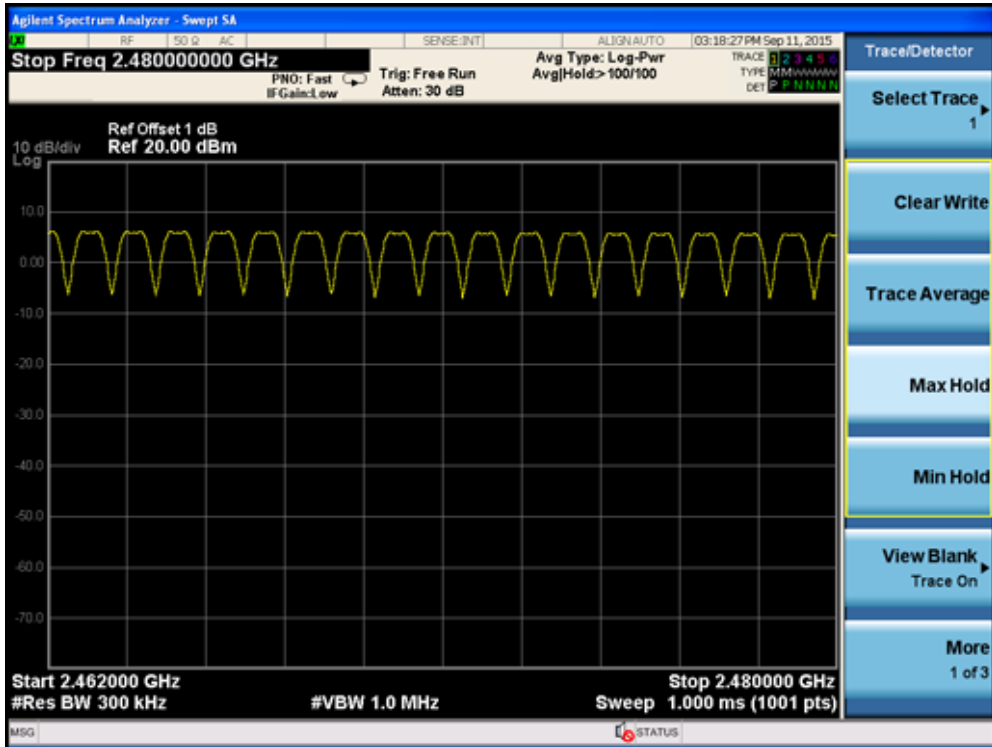

Product	:	IP-STB
Test Item	:	Number of Hopping Frequencies
Test Site	:	TR-8
Test Mode	:	Mode 2: Transmitter-2Mbps (Pi/4 DQPSK_DH5)

Frequency Band (MHz)	Number of Hopping Frequencies	Limit	Result
2400 - 2483.5	79	>15	Pass

2400 - 2421 MHz

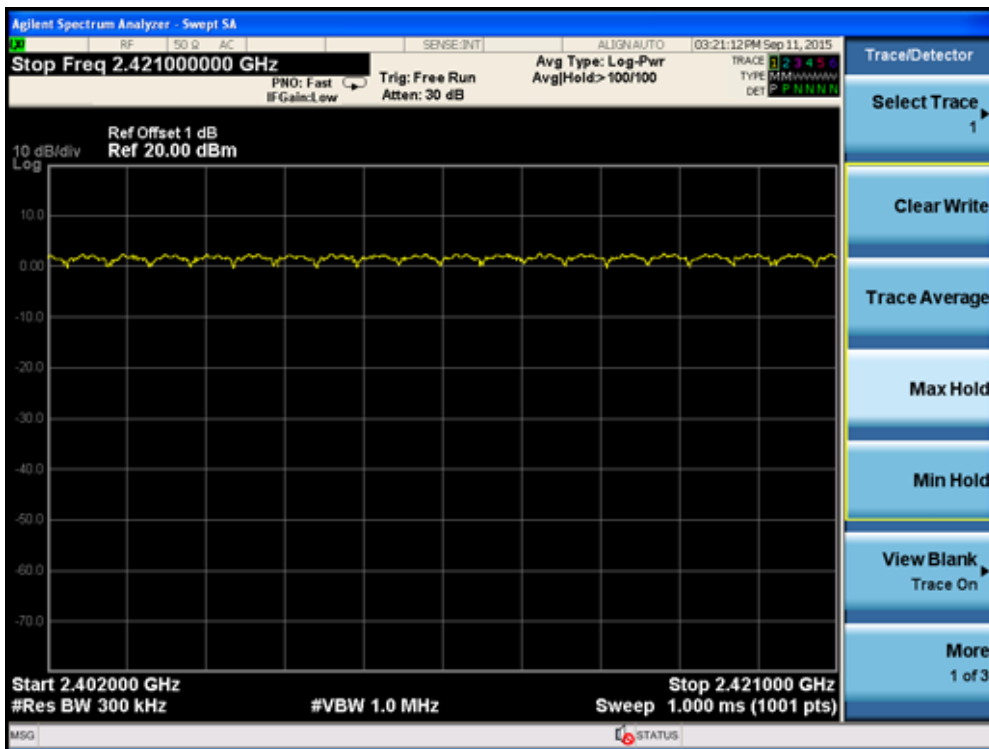

2422 - 2441 MHz

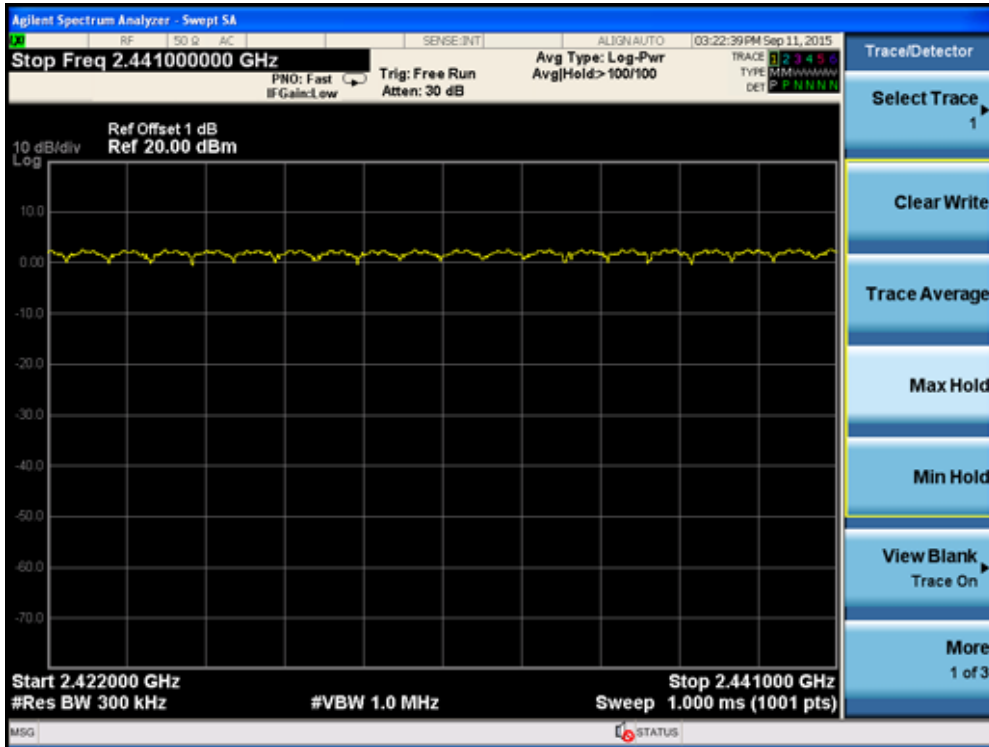

2442 - 2461 MHz

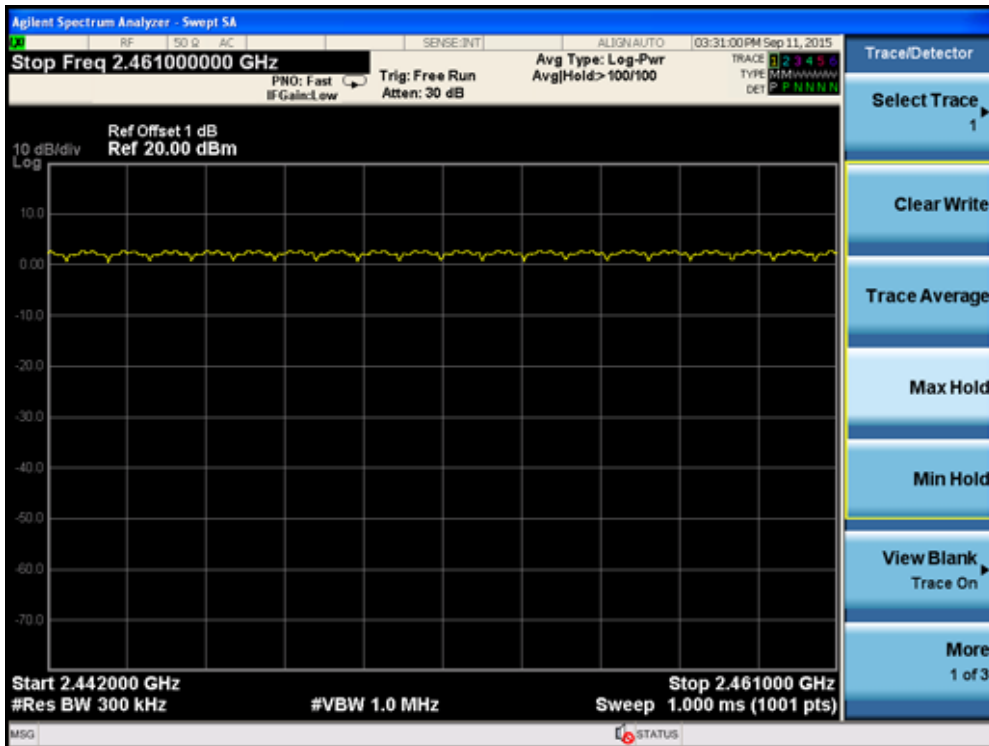

2462 - 2480 MHz

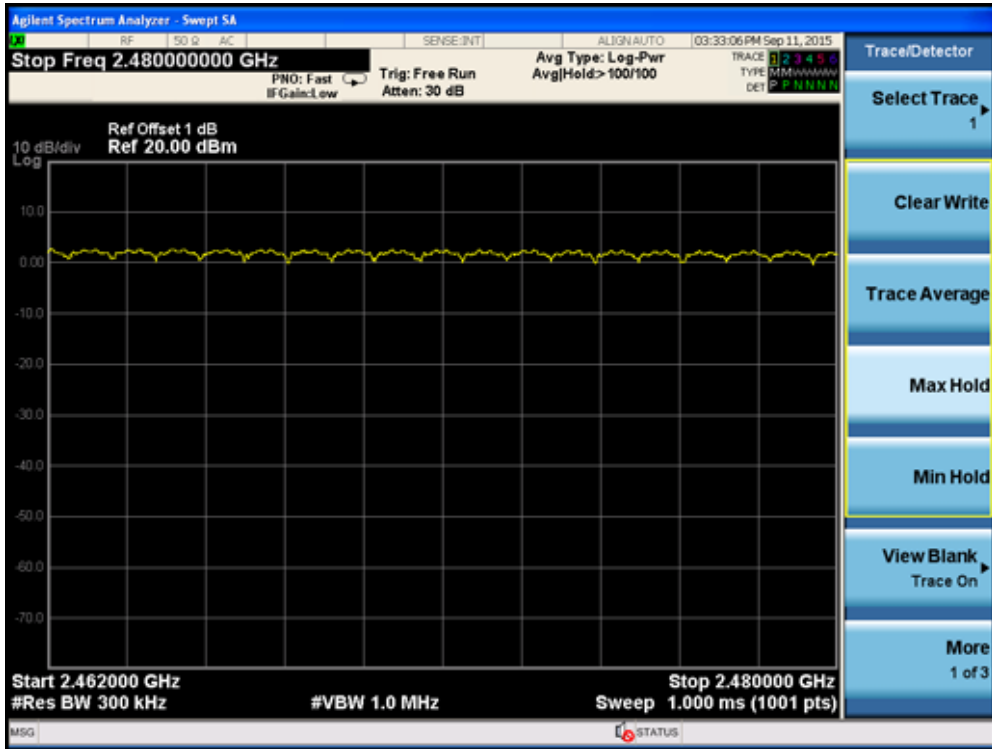

Product	:	IP-STB
Test Item	:	Number of Hopping Frequencies
Test Site	:	TR-8
Test Mode	:	Mode 3: Transmitter-3Mbps (8DPSK_DH5)

Frequency Band (MHz)	Number of Hopping Frequencies	Limit	Result
2400 - 2483.5	79	>15	Pass

2400 - 2421 MHz

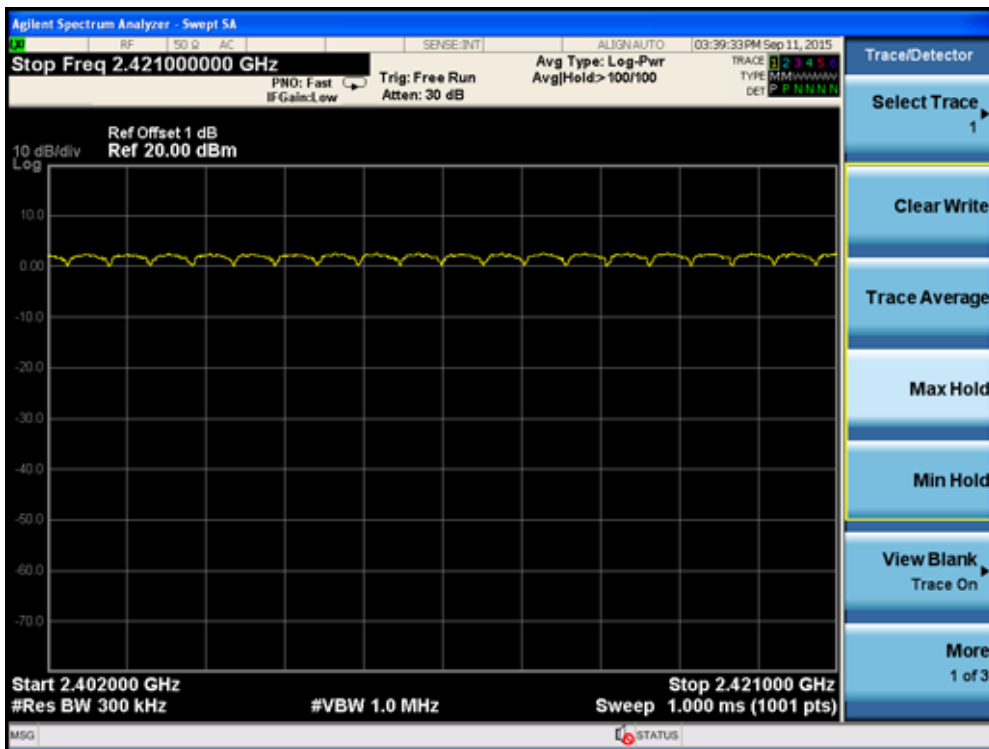

2422 - 2441 MHz

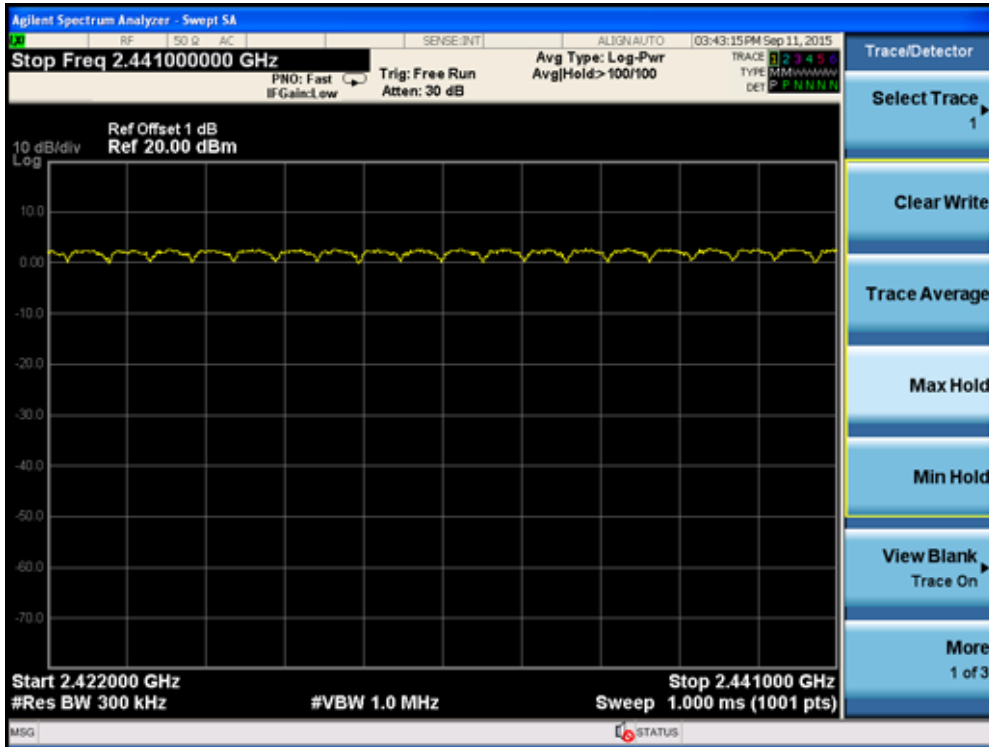

2442 - 2461 MHz

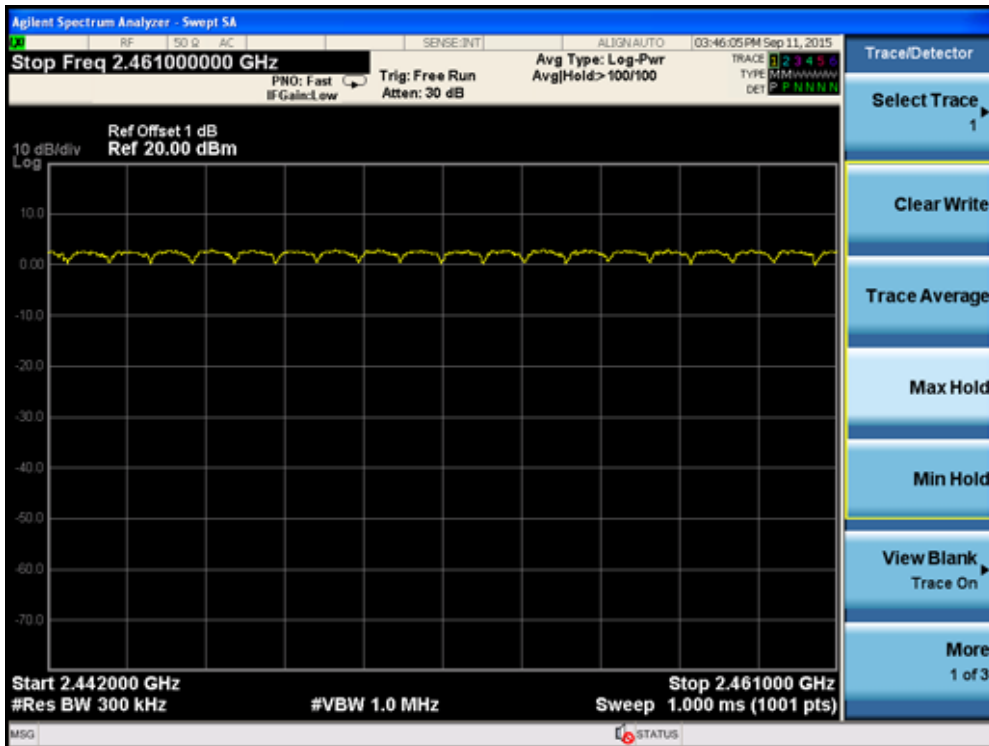

2462 - 2480 MHz

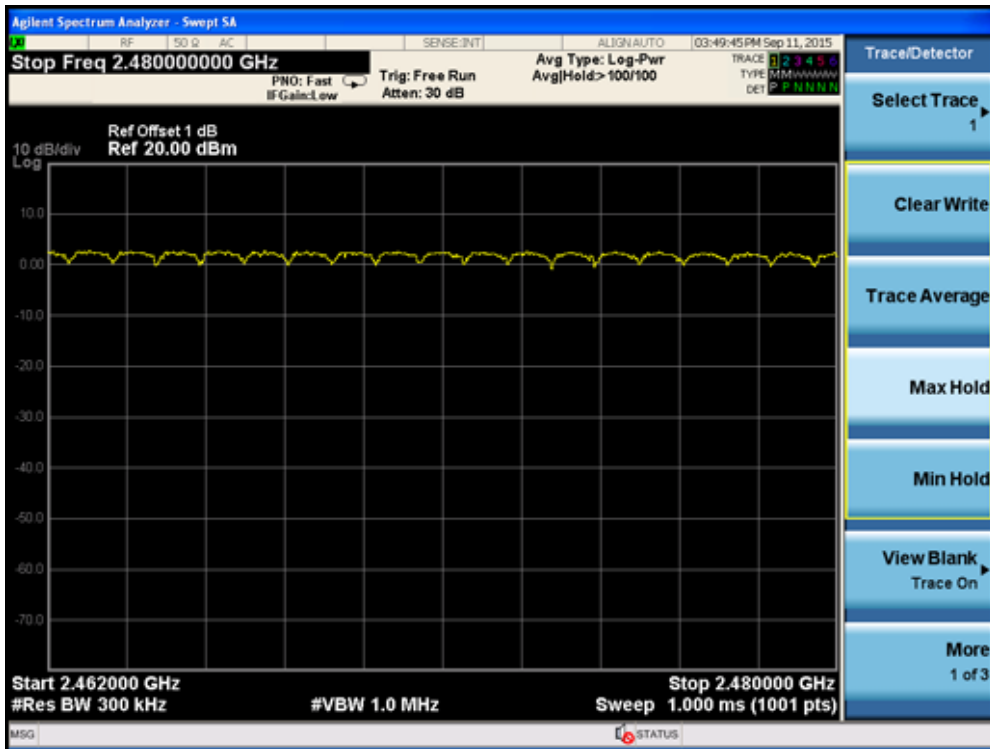

8. Time of Occupancy (Dwell Time)

8.1. Test Equipment

Time of Occupancy (Dwell Time) / TR-8

Instrument	Manufacturer	Type No.	Serial No.	Cal. Due Date
Spectrum Analyzer	Agilent	N9010A	MY48030494	2016.03.10
Temperature/Humidity Meter	Zhicheng	ZC1-2	TR8-TH	2016.04.09

Note: All equipments are calibrated with traceable calibrations. Each calibration is traceable to the national or international standards.

8.2. Test Setup

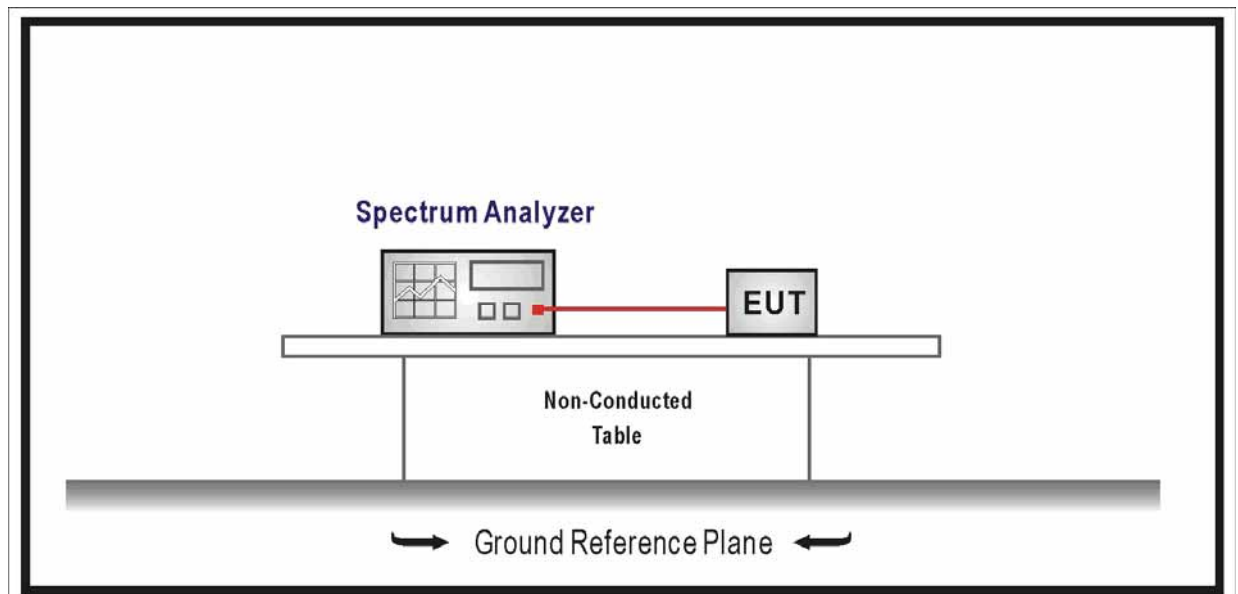

8.3. Limit

- For frequency hopping systems operating in the 902-928 MHz band: if the 20 dB bandwidth of the hopping channel is less than 250 kHz, the system shall use at least 50 hopping frequencies and the average time of occupancy on any frequency shall not be greater than 0.4 seconds within a 20 second period; If the 20 dB bandwidth of the hopping channel is 250 kHz or greater, the system shall use at least 25 hopping frequencies and the average time of occupancy on any frequency shall not be greater than 0.4 seconds within a 10 second period. The maximum allowed 20 dB bandwidth of the hopping channel is 500 kHz.
- Frequency hopping systems operating in the 5725-5850 MHz band shall use at least 75

hopping frequencies. The maximum 20 dB bandwidth of the hopping channel is 1 MHz. The average time of occupancy on any frequency shall not be greater than 0.4 seconds within a 30 second period.

- Frequency hopping systems in the 2400-2483.5 MHz band shall use at least 15 channels. The average time of occupancy on any channel shall not be greater than 0.4 seconds within a period of 0.4 seconds multiplied by the number of hopping channels employed. Frequency hopping systems may avoid or suppress transmissions on a particular hopping frequency provided that a minimum of 15 channels are used.

8.4. Test Procedure

According to ANSI C63.10: 2013& ANSI C63.4: 2014

The EUT must have its hopping function enabled. Use the following spectrum analyzer settings:

Span = zero span, centered on a hopping channel

RBW = 1MHz

VBW \cong RBW

Sweep = as necessary to capture the entire dwell time per hopping channel

Detector function = peak

Trace = max hold

If possible, use the marker-IP-STB function to determine the dwell time. If this value varies with different modes of operation (e.g., data rate, modulation format, etc.), repeat this test for each variation.

8.5. Uncertainty

The measurement uncertainty is defined as ± 0.1 us

8.6. Test Result

Product	:	IP-STB
Test Item	:	Time of Occupancy (Dwell Time)
Test Site	:	TR-8
Test Mode	:	Transmitter-1Mbps (GFSK_DH1)

Channel No.	Frequency (MHz)	Time of Occupancy (ms)	Limit (ms)	Result
39	2441	380.59	< 400	Pass

Test Time Period: $0.4 \times 79 = 31.6$ sec.

- 2441MHz, The Maximum Occupancy Time Within 31.6sec: $0.3746\text{ms} \times 1016 = 380.59\text{msec}$

Channel 39 (2441MHz)-(DH1)

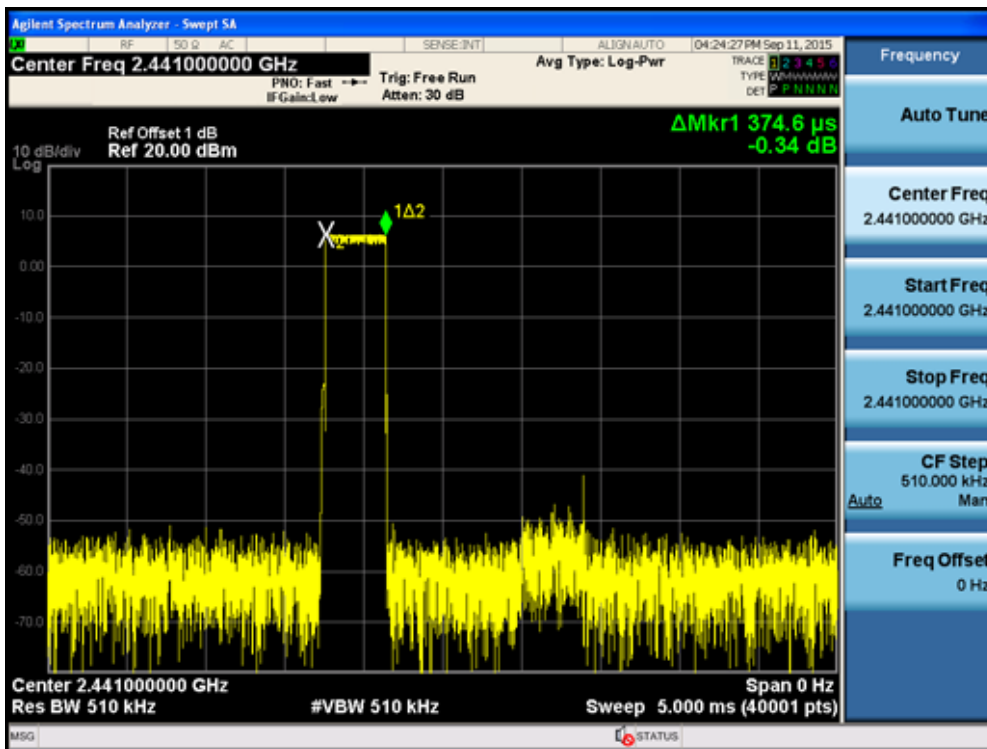

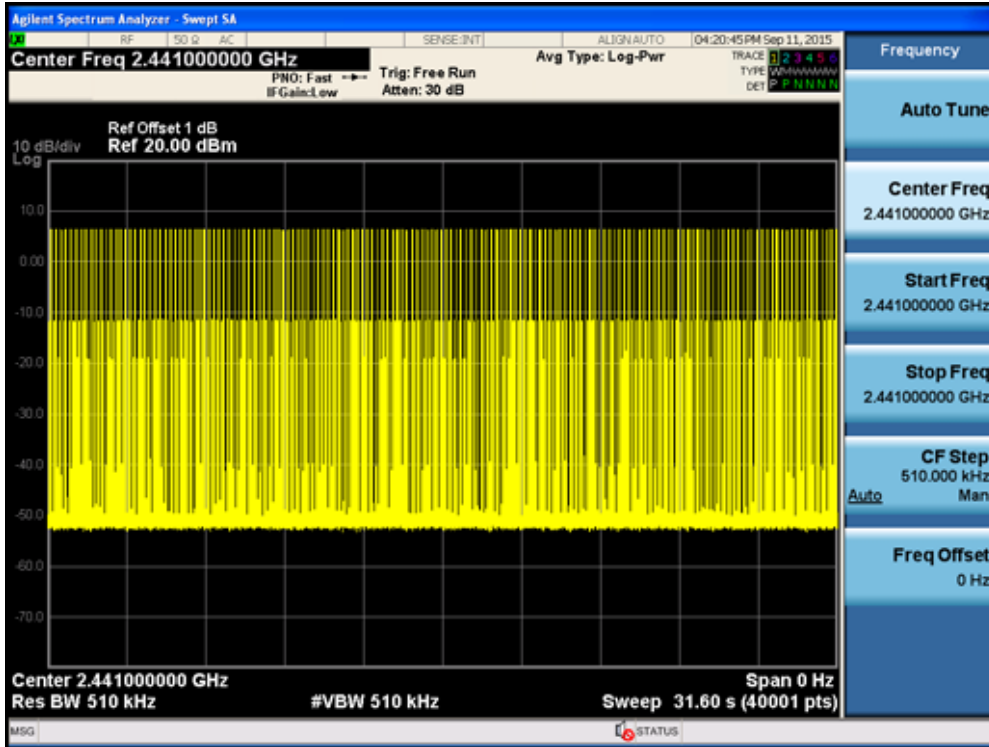

Product	:	IP-STB
Test Item	:	Time of Occupancy (Dwell Time)
Test Site	:	TR-8
Test Mode	:	Transmitter-1Mbps (GFSK_DH3)

Channel No.	Frequency (MHz)	Time of Occupancy (ms)	Limit (ms)	Result
39	2441	263.57	< 400	Pass

Test Time Period: $0.4 \times 79 = 31.6$ sec.

- 2441MHz, The Maximum Occupancy Time Within 31.6sec: $1.627\text{ms} \times 162 = 263.57\text{msec}$

Channel 39 (2441MHz) - (DH3)

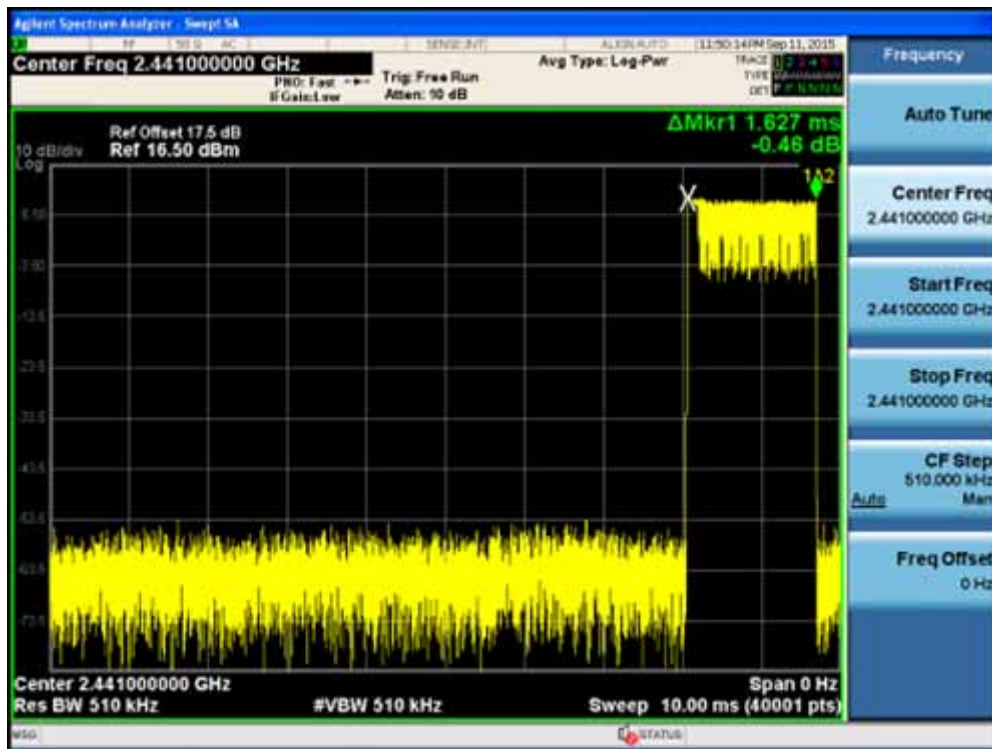

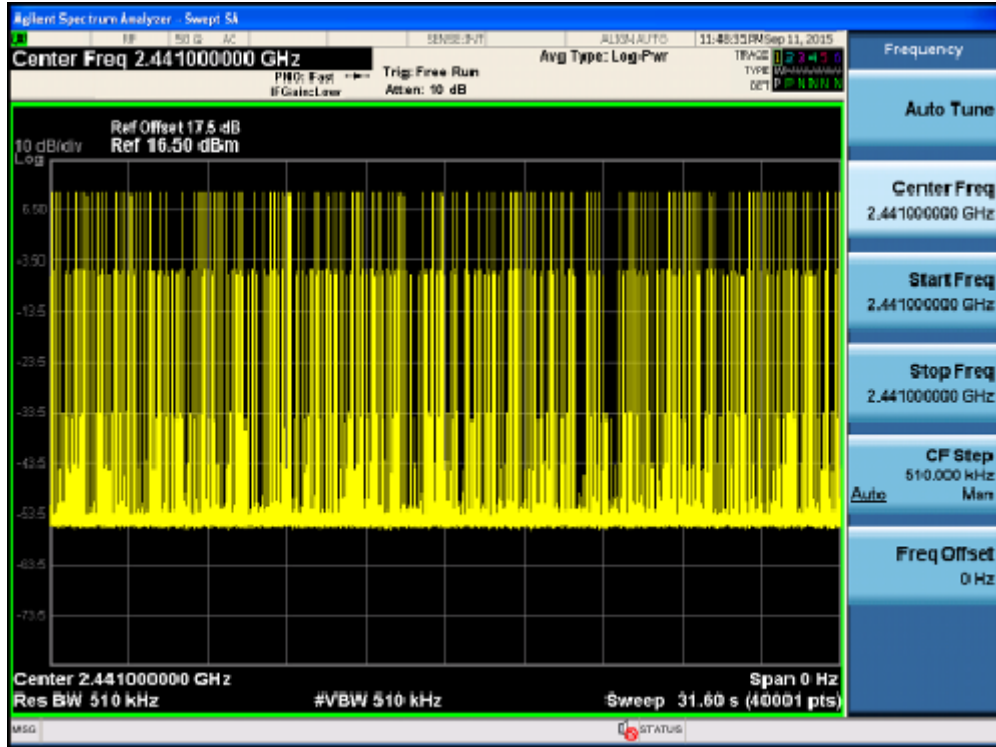

Product	:	IP-STB
Test Item	:	Time of Occupancy (Dwell Time)
Test Site	:	TR-8
Test Mode	:	Transmitter-1Mbps (GFSK_DH5)

Channel No.	Frequency (MHz)	Time of Occupancy (ms)	Limit (ms)	Result
39	2441	392.36	< 400	Pass

Test Time Period: $0.4 \times 79 = 31.6$ sec.

- 2441MHz, The Maximum Occupancy Time Within 31.6sec: $2.885\text{ms} \times 136 = 392.36\text{msec}$

Channel 39 (2441MHz) - (DH5)

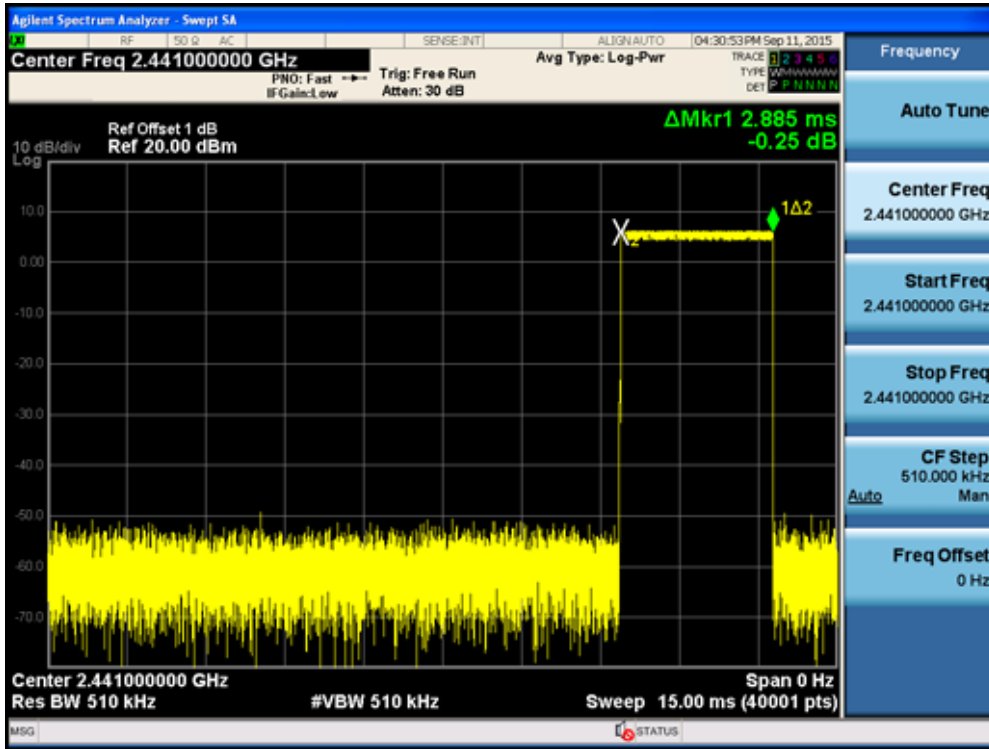

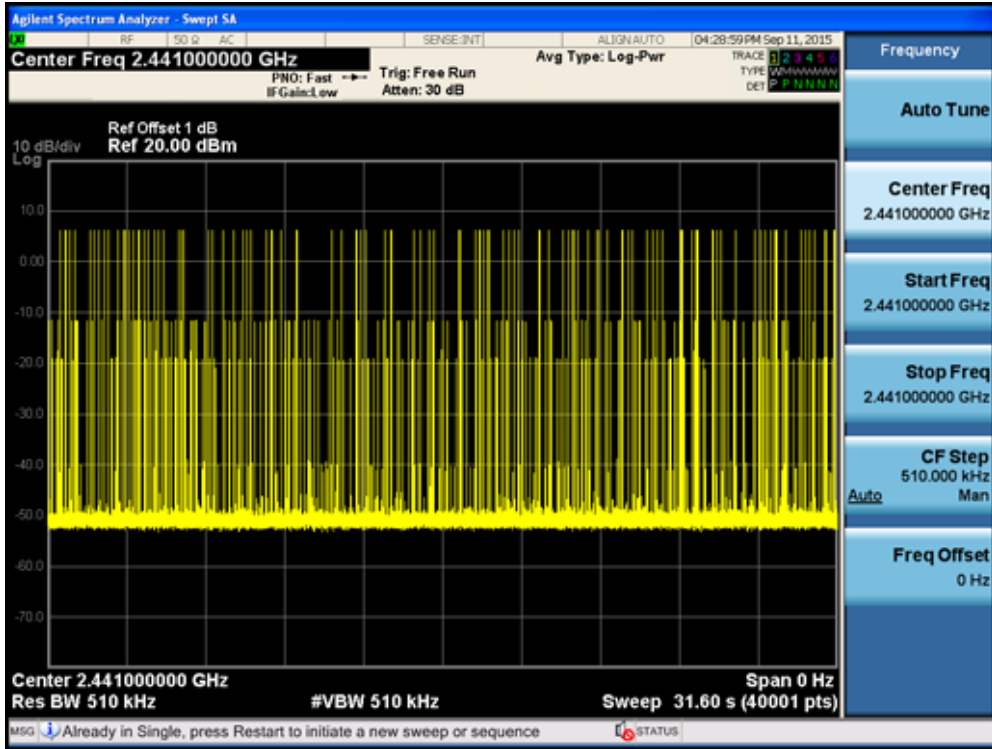

9. Peak Output Power

9.1. Test Equipment

Peak Output Power / TR-8

Instrument	Manufacturer	Type No.	Serial No.	Cal. Due Date
Spectrum Analyzer	Agilent	N9010A	MY48030494	2016.03.10
Temperature/Humidity Meter	Zhicheng	ZC1-2	TR8-TH	2016.04.09

Note: All equipments are calibrated with traceable calibrations. Each calibration is traceable to the national or international standards.

9.2. Test Setup

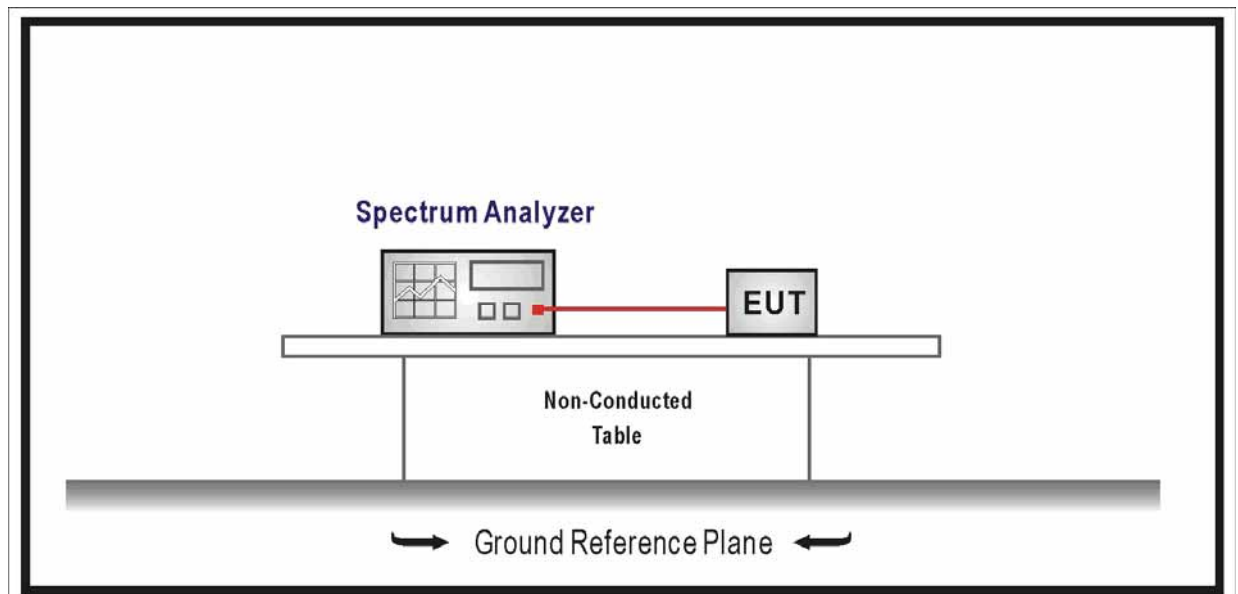

9.3. Limit

- For frequency hopping systems operating in the 2400-2483.5 MHz band employing at least 75 non-overlapping hopping channels, and all frequency hopping systems in the 5725-5850 MHz band: 1 watt. For all other frequency hopping systems in the 2400-2483.5 MHz band: 0.125 watts.
- For frequency hopping systems operating in the 902-928 MHz band: 1 watt for systems employing at least 50 hopping channels; and, 0.25 watts for systems employing less than 50 hopping channels, but at least 25 hopping channels.

Note: the conducted output power limit specified above is based on the use the antennas with

directional gains that do not exceed 6 dBi are used, the conducted output power from the intentional radiator shall be reduced below the stated values above, as appropriate, by the amount in dB that the directional gain of antenna exceeds 6 dBi.

9.4. Test Procedure

According to ANSI C63.10: 2013& ANSI C63.4: 2014

Use the following spectrum analyzer settings:

Span = approximately 5 times the 20dB bandwidth, centered on a hopping channel

RBW > the 20 dB bandwidth of the emission being measured.

VBW \cong RBW

Sweep = auto

Detector function = peak

Trace = max hold

Allow the trace to stabilize. Use the marker-to-peak function to set the marker to the peak of the emission. The indicated level is the peak output power (don't forget added the external attenuation and cable loss).

9.5. Uncertainty

The measurement uncertainty is defined as ± 1.0 dB

9.6. Test Result

Product	:	IP-STB
Test Item	:	Power Output
Test Mode	:	Mode 1: Transmitter-1Mbps (GFSK_DH5)

Channel No.	Frequency (MHz)	Measurement Power Output (dBm)	Limit (dBm)	Result
0	2402	5.896	30.00	Pass
39	2441	6.405	30.00	Pass
78	2480	4.007	30.00	Pass

DH5 2402MHz



Product	:	IP-STB
Test Item	:	Power Output
Test Mode	:	Mode 2: Transmitter-2Mbps (Pi/4 DQPSK_DH5)

Channel No.	Frequency (MHz)	Measurement Power Output (dBm)	Limit (dBm)	Result
0	2402	3.510	30.00	Pass
39	2441	3.905	30.00	Pass
78	2480	3.567	30.00	Pass

2DH5 2402MHz

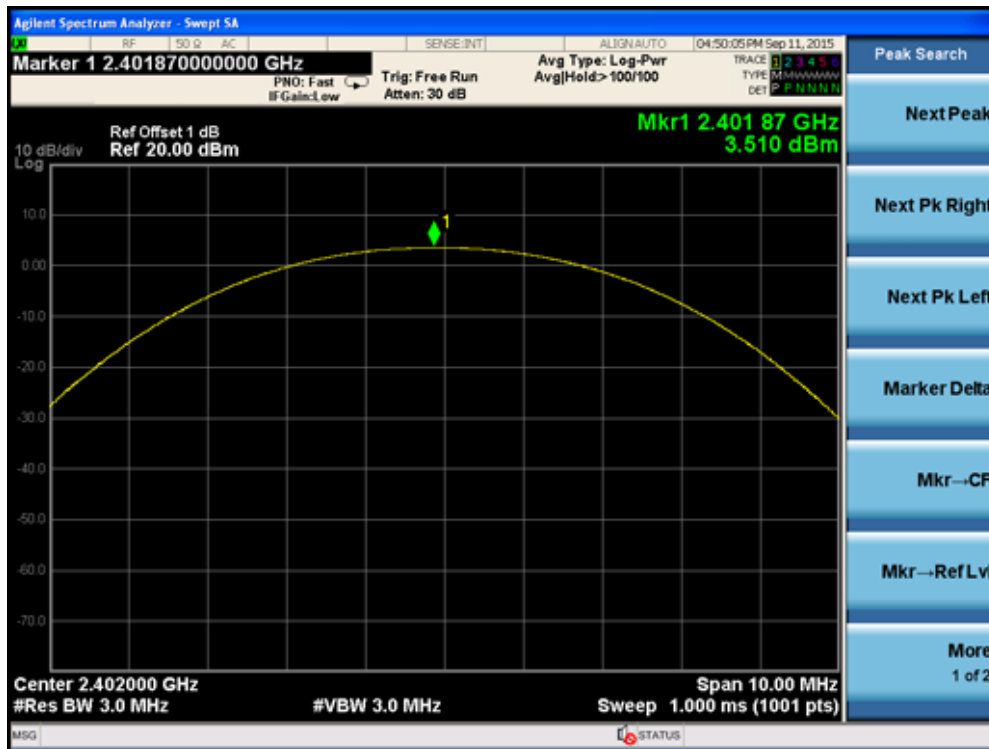

2DH5 2441MHz

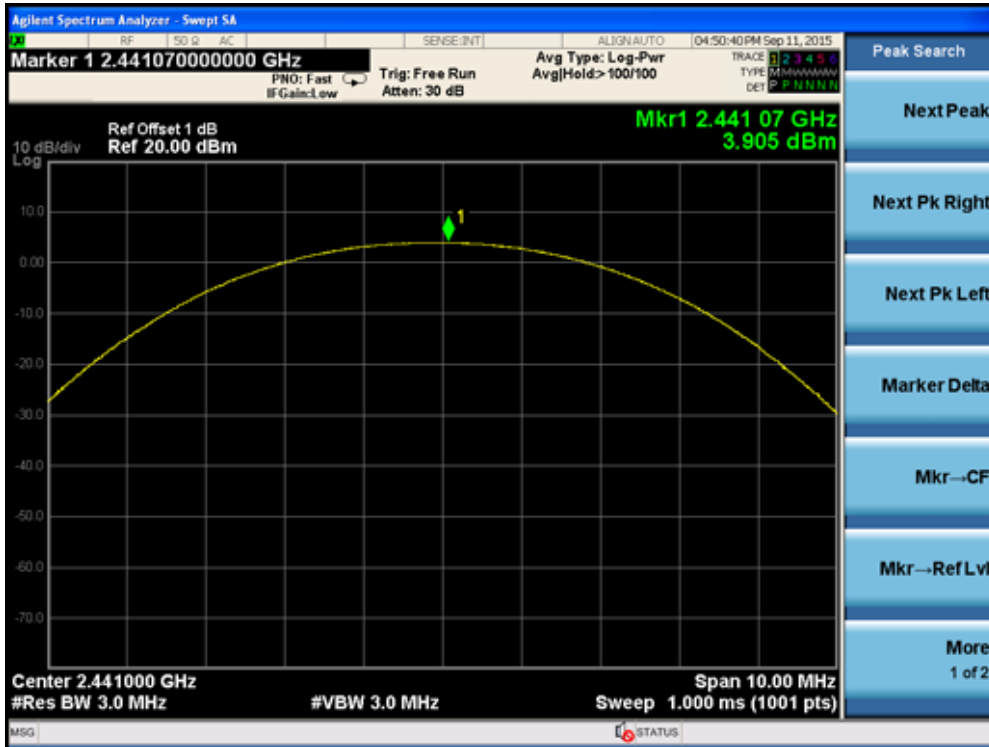

2DH5 2480MHz

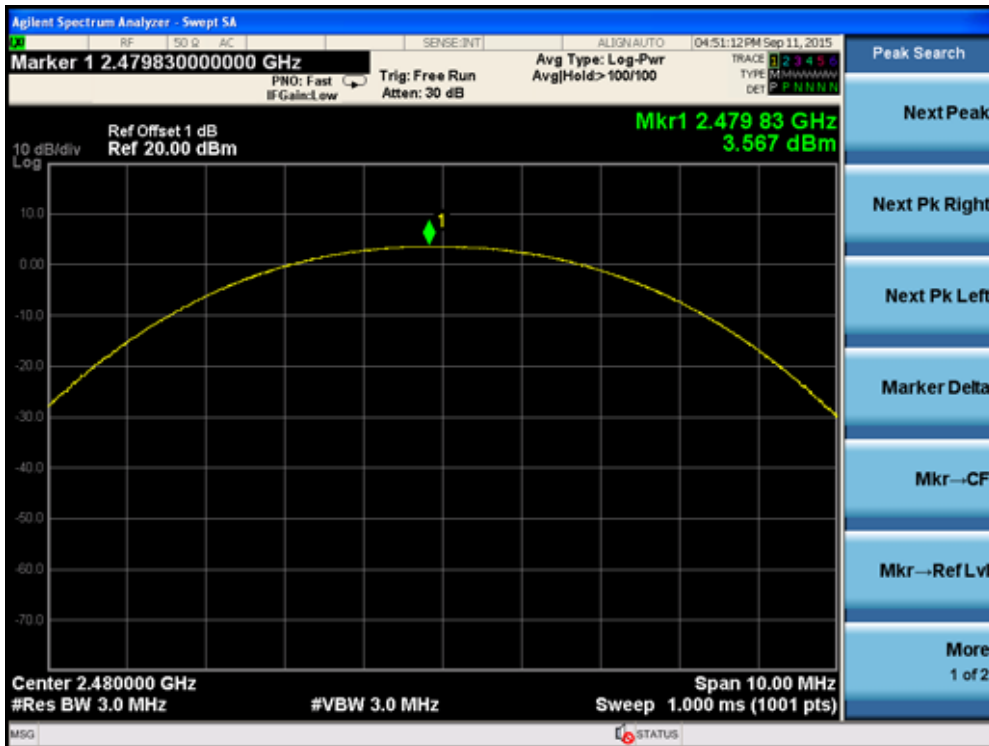

Product	:	IP-STB
Test Item	:	Power Output
Test Mode	:	Mode 3: Transmitter-3Mbps (8DPSK_DH5)

Channel No.	Frequency (MHz)	Measurement Power Output (dBm)	Limit (dBm)	Result
0	2402	3.914	30.00	Pass
39	2441	4.345	30.00	Pass
78	2480	4.030	30.00	Pass

3DH5 2402MHz

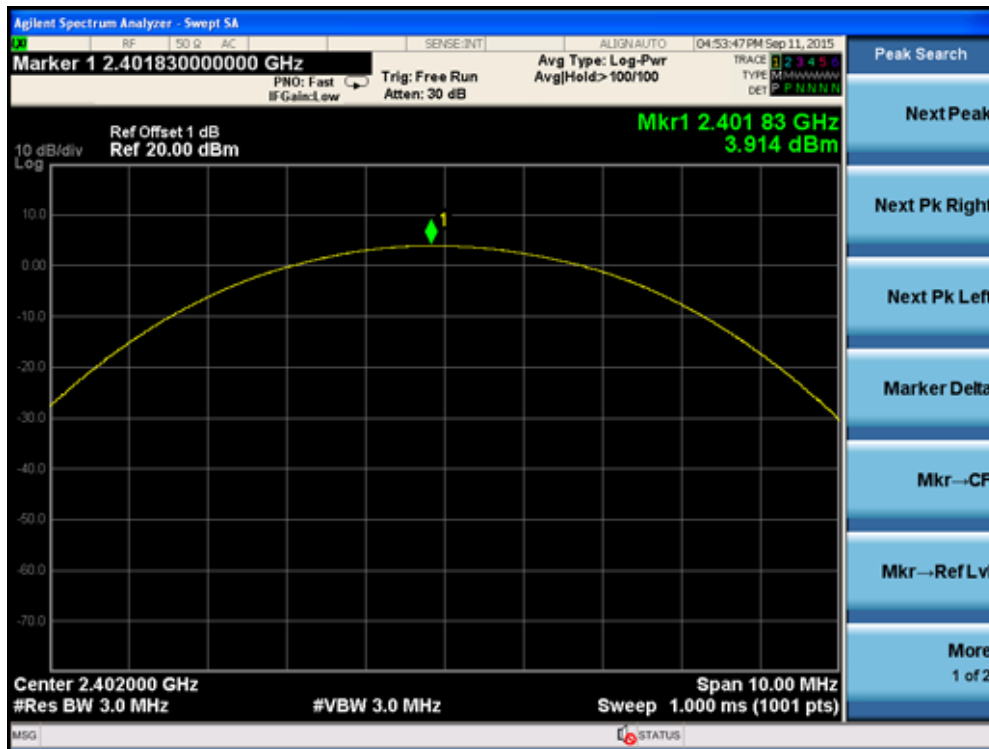

10. Band-edge Compliance of RF Conducted Emissions

10.1. Test Equipment

Band-edge Compliance of RF Conducted Emissions / TR-8

Instrument	Manufacturer	Type No.	Serial No.	Cal. Due Date
Spectrum Analyzer	Agilent	N9010A	MY48030494	2016.03.10
Temperature/Humidity Meter	Zhicheng	ZC1-2	TR8-TH	2016.04.09

Note: All equipments are calibrated with traceable calibrations. Each calibration is traceable to the national or international standards.

10.2. Test Setup

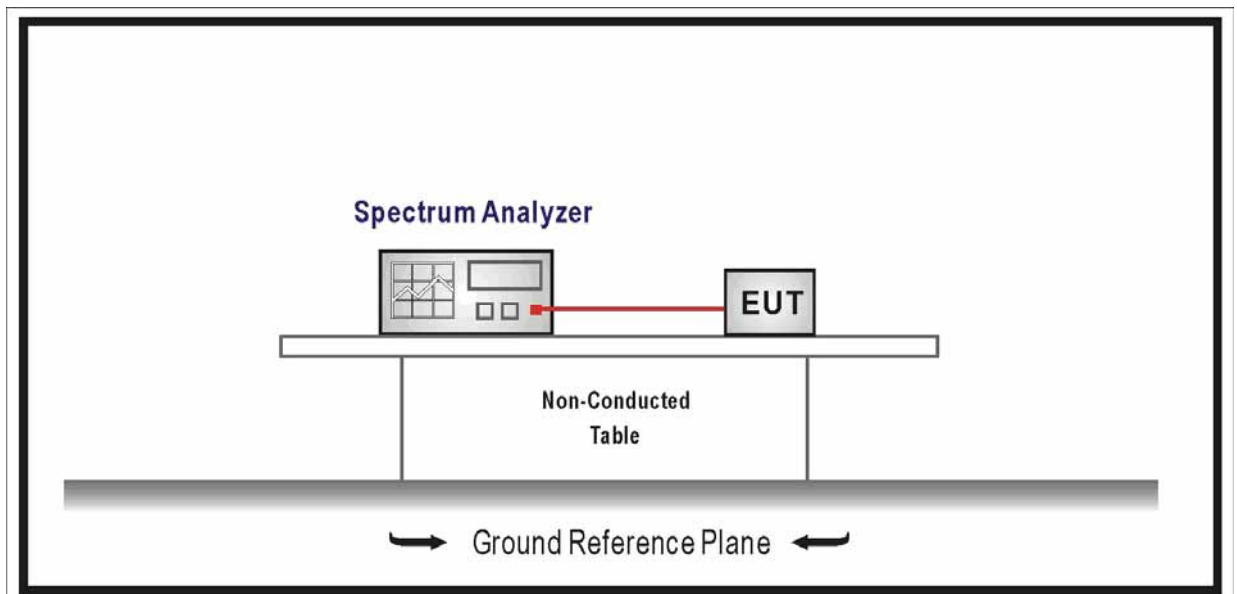

10.3. Limit

- Intentional radiators operating under the alternative provisions to the general emission limits as contained in 15.217 through 15.257 and in Subpart E of FCC part 15, must be designed to ensure that 20 dB bandwidth of the emission, or whatever bandwidth may otherwise be specified in the specific rule section under which the equipment operates, is contained within the frequency band designated in the rule section under which the equipment is operated.
- In any 100 kHz bandwidth outside the frequency band in which the spread spectrum or digitally modulated intentional radiator is operating, the radio frequency power that is produced by the intentional radiator shall be at least 20 dB below that in the 100 kHz

bandwidth within the band that contains the highest level of the desired power, based on either an RF conducted or a radiated measurement, provided the transmitter demonstrates compliance with the peak conducted or a radiated measurement, provided the transmitter demonstrates compliance with the peak conducted power limits. If the transmitter complies with the conducted power limits based on the use of RMS averaging over a time interval, the attenuation required under this paragraph shall be 30 dB instead of 20 dB. Attenuation below the general limits specified in Section 15.209(a) of FCC part 15 is not required.

10.4. Test Procedure

According to ANSI C63.10: 2013& ANSI C63.4: 2014

Use the following spectrum analyzer settings:

Span = wide enough to capture the peak level of the emission operating on the channel closest to the bandedge, as well as any modulation products which fall outside of the authorized band of operation.

RBW \cong 1% of the span

VBW \cong RBW

Sweep = auto

Detector function = peak

Trace = max hold

Allow the trace to stabilize. Set the marker on the emission at the bandedge, or on the highest modulation product outside of the band, if this level is greater than that at the bandedge.

Enable the marker-IP-STB function, then use the marker-to-peak function to move the marker to the peak of the in-band emission. The marker-IP-STB value now displayed must comply with the limit specified in this Section.

Now, using the same instrument settings, enable the hopping function of the EUT. Allow the trace to stabilize. Follow the same procedure listed above to determine if any spurious emissions caused by the hopping function also comply with the specified limit.

10.5. Uncertainty

The measurement uncertainty is defined as ± 1.0 dB

10.6. Test Result

Product	:	IP-STB
Test Item	:	Band-edge Compliance of RF Conducted Emissions
Test Site	:	TR-8
Test Mode	:	Mode 1: Transmitter-1Mbps (GFSK_DH5)

Channel 00 (2402MHz)

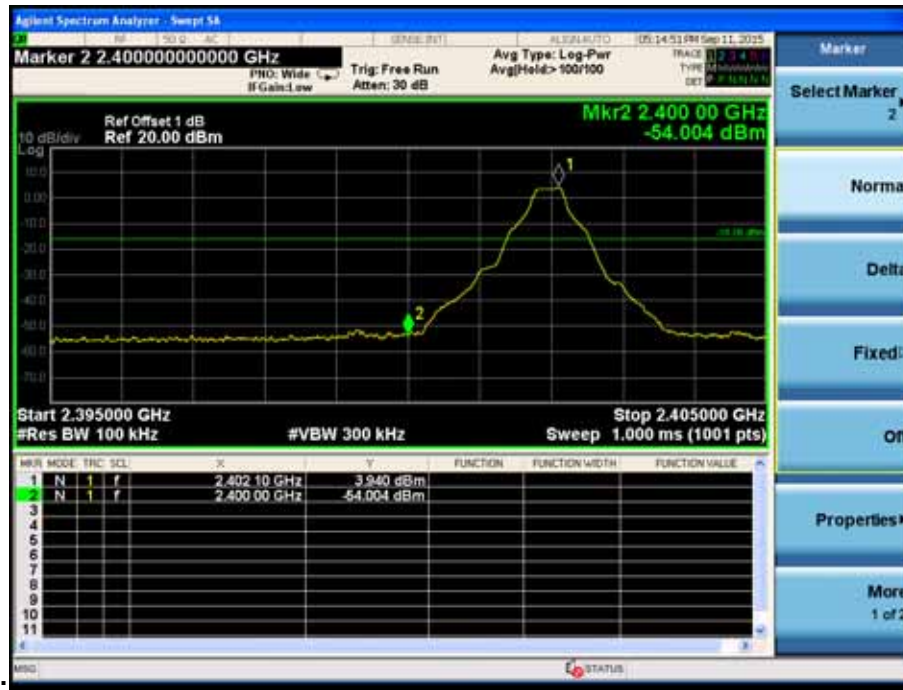

Channel 78 (2480MHz)

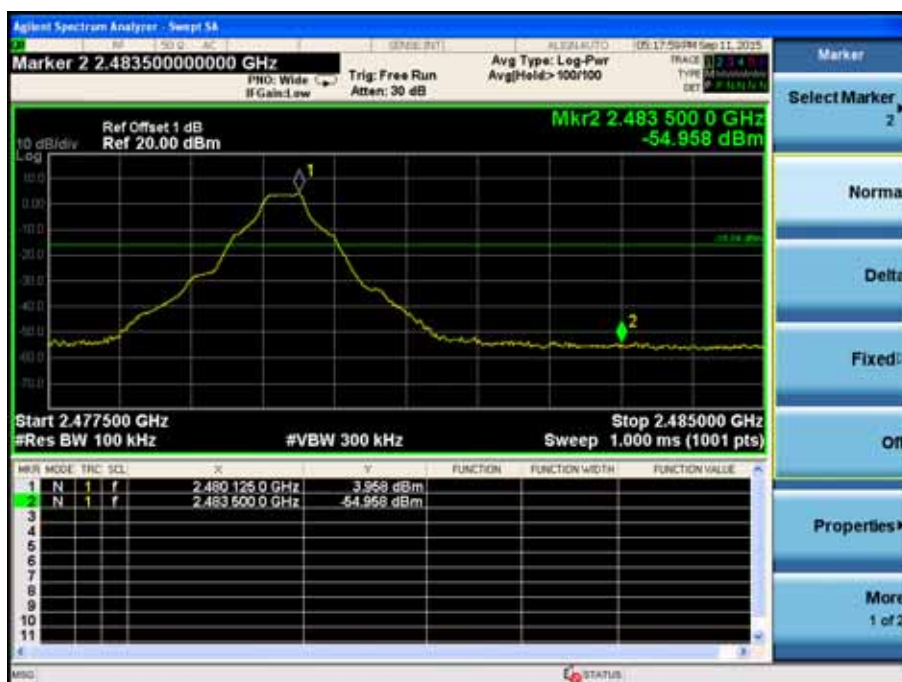

Product	: IP-STB
Test Item	: Band-edge Compliance of RF Conducted Emissions
Test Site	: TR-8
Test Mode	: Mode 2: Transmitter-2Mbps (Pi/4 DQPSK_DH5)

Channel 00 (2402MHz)

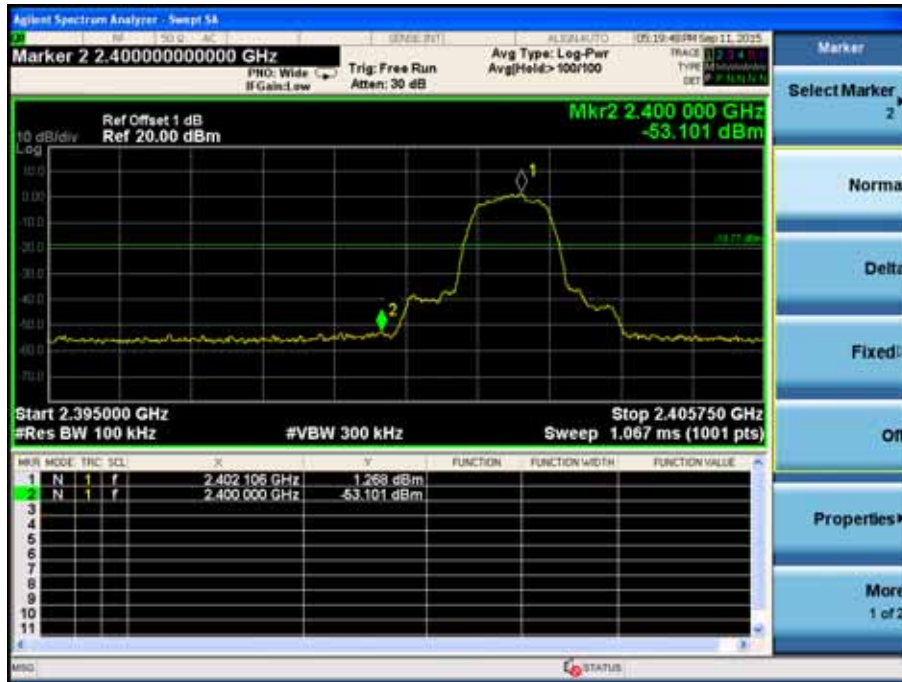

Channel 78 (2480MHz)

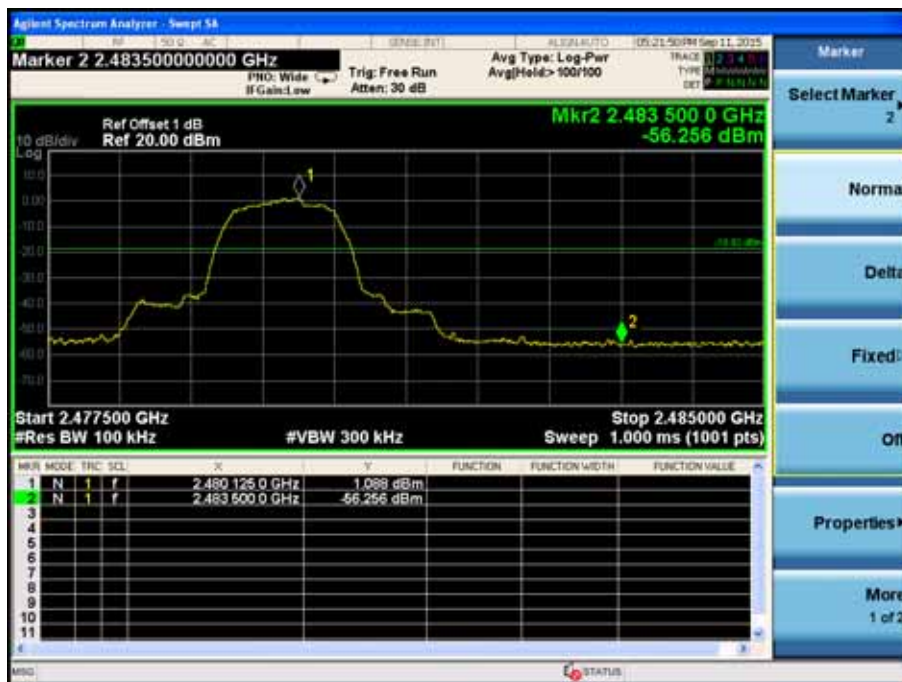

Product	: IP-STB
Test Item	: Band-edge Compliance of RF Conducted Emissions
Test Site	: TR-8
Test Mode	: Mode 3: Transmitter-3Mbps (8DPSK_DH5)

Channel 00 (2402MHz)

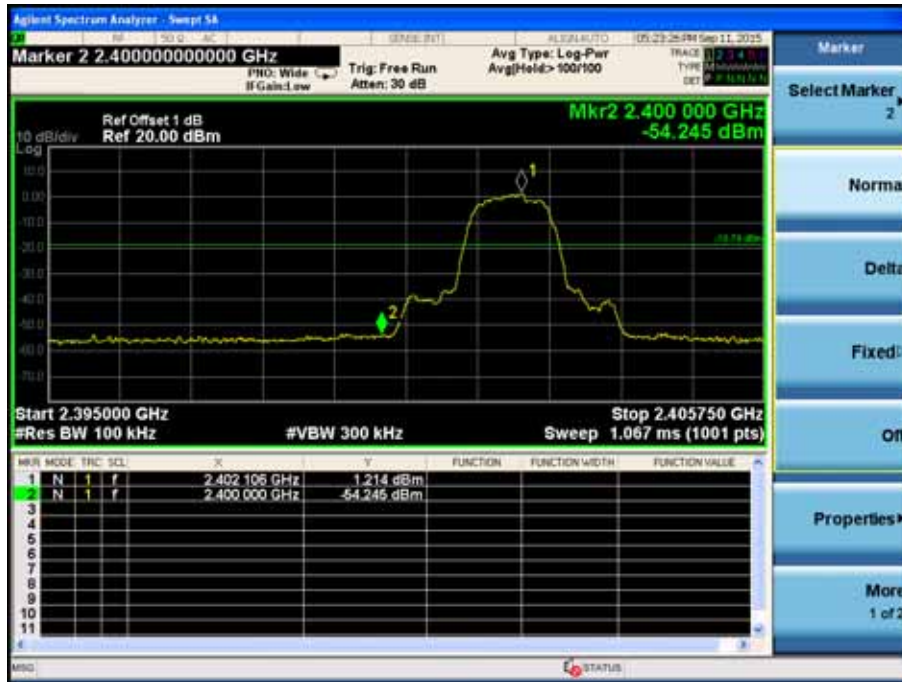

Channel 78 (2480MHz)

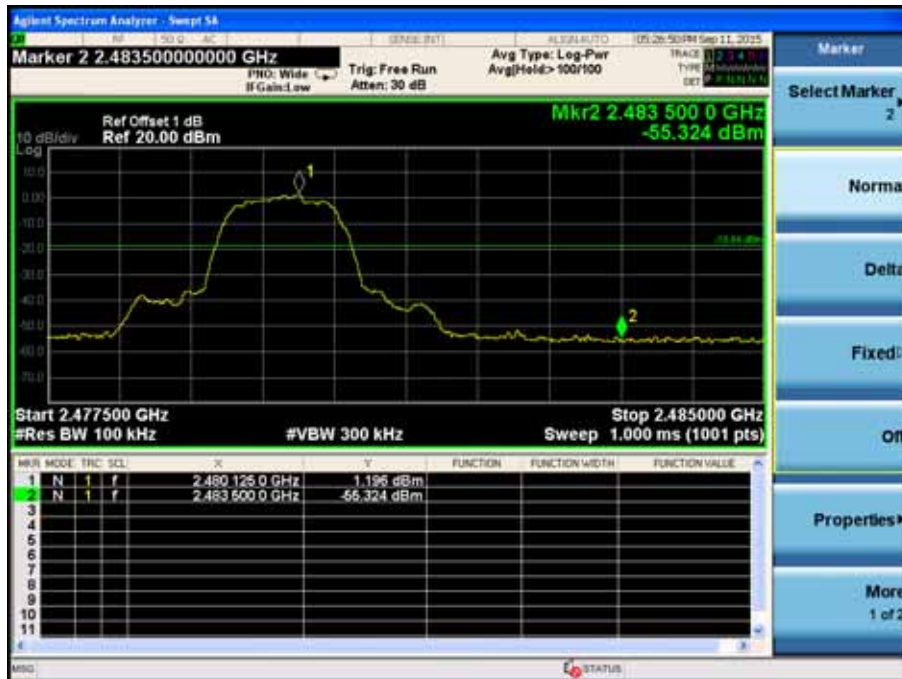

Product	:	IP-STB
Test Item	:	Band-edge Compliance of RF Conducted Emissions
Test Site	:	TR-8
Test Mode	:	Mode: Hopping Mode

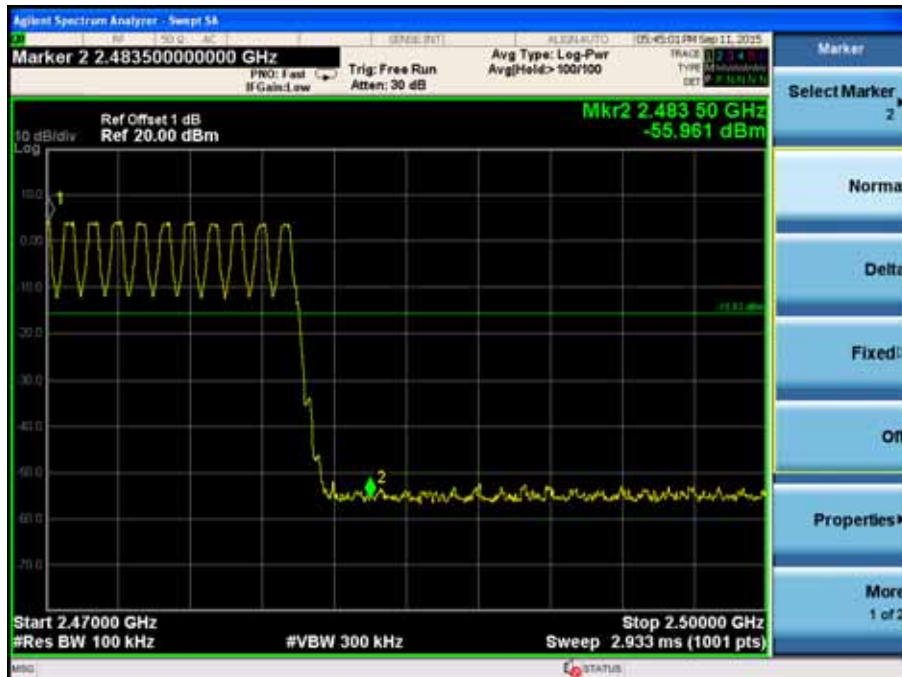
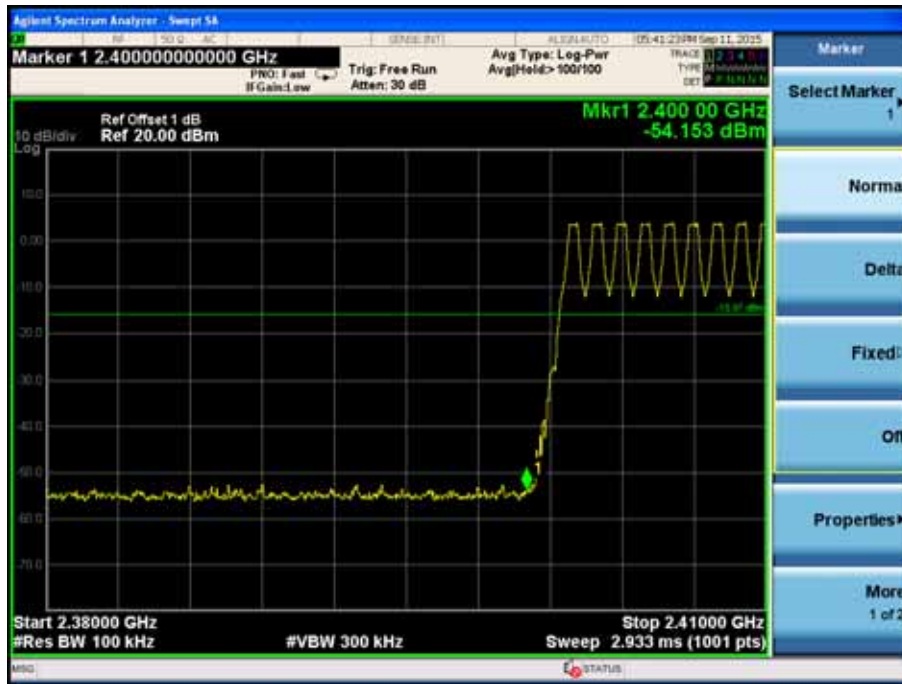

11. Spurious RF Conducted Emissions

11.1. Test Equipment

Spurious RF Conducted Emissions / TR-8

Instrument	Manufacturer	Type No.	Serial No.	Cal. Due Date
Spectrum Analyzer	Agilent	N9010A	MY48030494	2016.03.10
Temperature/Humidity Meter	Zhicheng	ZC1-2	TR8-TH	2016.04.09

Note: All equipments are calibrated with traceable calibrations. Each calibration is traceable to the national or international standards.

11.2. Test Setup

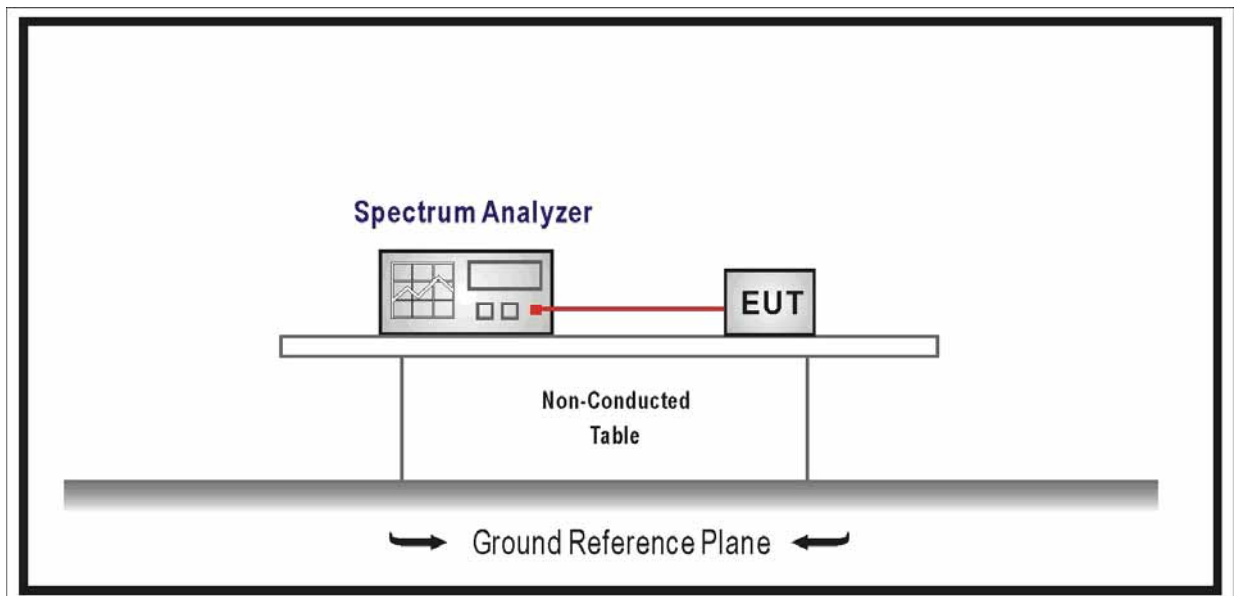

11.3. Limit

In any 100 kHz bandwidth outside the frequency band in which the spread spectrum or digitally modulated intentional radiator is operating, the radio frequency power that is produced by the intentional radiator shall be at least 20 dB below that in the 100 kHz bandwidth within the band that contains the highest level of the desired power, based on either an RF conducted or a radiated measurement, provided the transmitter demonstrates compliance with the peak conducted or a radiated measurement, provided the transmitter demonstrates compliance with the peak conducted power limits. If the transmitter complies with the conducted power limits based on the use of RMS averaging over a time interval, the attenuation required under this paragraph shall be 30 dB instead of 20 dB. Attenuation below the general limits specified in

Section 15.209(a) of FCC part 15 is not required.

11.4. Test Procedure

According to ANSI C63.10: 2013.

Use the following spectrum analyzer settings:

Span = wide enough to capture the peak level of the in-band emission and all spurious emissions (e.g., harmonics) from the lowest frequency generated in the EUT up through the 10th harmonic. Typically, several plots are required to cover this entire span.

RBW = 100 kHz

VBW \cong RBW

Sweep = auto

Detector function = peak

Trace = max hold

Allow the trace to stabilize. Set the marker on the peak of any spurious emission recorded.

The level displayed must comply with the limit specified in this section.

11.5. Uncertainty

The measurement uncertainty is defined as ± 1.0 dB

11.6. Test Result

Product	:	IP-STB
Test Item	:	Spurious RF Conducted Emissions
Test Mode	:	Mode 1: Transmitter-1Mbps (GFSK_DH5)

Channel 00 (2402MHz)



Channel 39 (2441MHz)



Channel 78 (2480MHz)



Product	:	IP-STB
Test Item	:	Spurious RF Conducted Emissions
Test Mode	:	Mode 2: Transmitter-2Mbps (Pi/4 DQPSK_DH5)

Channel 00 (2402MHz)



Channel 39 (2441MHz)



Channel 78 (2480MHz)



Product	:	IP-STB
Test Item	:	Spurious RF Conducted Emissions
Test Mode	:	Mode 3: Transmitter-3Mbps (8DPSK_DH5)

Channel 00 (2402MHz)



Channel 39 (2441MHz)



Channel 78 (2480MHz)



12. Radiated Emission Band Edge

12.1. Test Equipment

Radiated Emission Band Edge / AC-5

Instrument	Manufacturer	Type No.	Serial No.	Cal. Due Date
Spectrum Analyzer	Agilent	N9010A	MY48030494	2016.03.10
Preamplifier	Miteq	NSP1800-25	1364185	2016.05.03
Preamplifier	Quietek	AP-040G	CHM-0906001	2016.05.03
Bilog Antenna	Teseq GmbH	CBL6112D	27612	2015.10.15
Broad-Band Horn Antenna	Schwarzbeck	BBHA9120D	733	2016.02.26
DRG Horn	ETS-Lindgren	3117	00167055	2016.07.16
Broad-Band Horn Antenna	Schwarzbeck	BBHA9170	294	2016.03.01
Coaxial Cable	Huber+Suhner	SUCOFLEX 106	AC5-C1	2016.03.01
Coaxial Cable	Huber+Suhner	SUCOFLEX 106	AC5-C2	2016.03.01
Coaxial Cable	Huber+Suhner	SUCOFLEX 102	AC5-C3	2016.08.07
Temperature/Humidity Meter	Zhicheng	ZC1-2	AC5-TH	2016.01.07

12.2. Test Setup

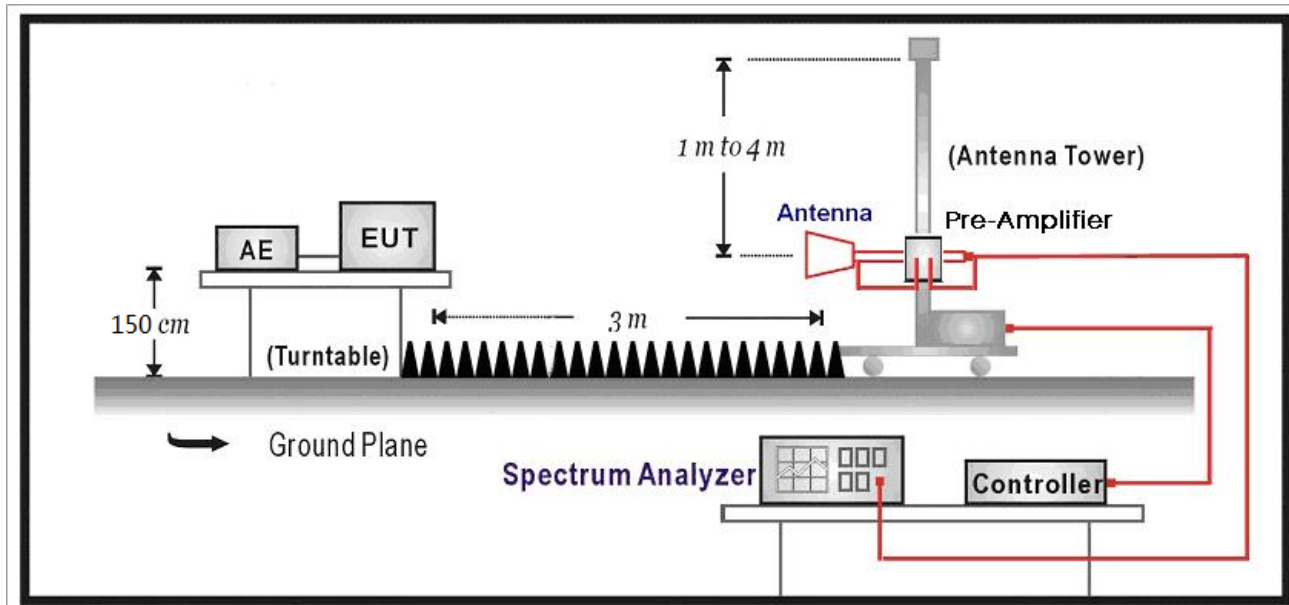

12.3. Limit

Radiated emissions which fall in the restricted bands, as defined in Section 15.205(a) of FCC part 15, must also comply with the radiated emission limits specified in Section 15.209(a) of FCC part 15.

12.4. Test Procedure

According to ANSI C63.10: 2013& ANSI C63.4: 2014

This test is required for any spurious emission or modulation product that falls in a Restricted Band, as defined in Section 15.205 of FCC part 15. It must be performed with the highest gain of each type of antenna proposed for use with the EUT. Use the following spectrum analyzer settings:

Span = wide enough to fully capture the emission being measured

RBW = 1 MHz for $f \geq 1$ GHz, 100 kHz for $f < 1$ GHz

VBW \geq RBW

Sweep = auto

Detector function = peak

Trace = max hold

Follow the guidelines in ANSI C63.4 with respect to maximizing the emission by rotating the EUT, measuring the emission while the EUT is situated in three orthogonal planes (if appropriate), adjusting the measurement antenna height and polarization, etc. A pre-amp and a high pass filter are required for this test, in order to provide the measuring system with

sufficient sensitivity. Allow the trace to stabilize. The peak reading of the emission, after being corrected by the antenna factor, cable loss, pre-amp gain, etc., is the peak field strength, which must comply with the limit specified in Section 15.35(b) of FCC part 15.

Now set the VBW to 10 Hz, while maintaining all of the other instrument settings. This peak level, once corrected, must comply with the limit specified in Section 15.209 of FCC Part 15. If the dwell time per channel of the hopping signal is less than 100 ms, then the reading obtained with the 10 Hz VBW may be further adjusted by a “duty cycle correction factor”, derived from $20\log(\text{dwell time}/100 \text{ ms})$, in an effort to demonstrate compliance with the 15.209 limit of FCC part 15.

If the emission on which a radiated measurement must be made is located at the edge of the authorized band of operation, then the alternative “marker-IP-STB” method may be employed.

12.5. Uncertainty

The measurement uncertainty above 1GHz is defined as $\pm 3.9 \text{ dB}$

below 1GHz is defined as $\pm 3.8 \text{ dB}$

12.6. Test Result

All of the test result shown indicates the worst case, and spectrum analyzer parameters setting as shown below:

Peak detector: RBW = 1MHz, VBW = 3MHz, sweep time = 100ms;

Average = Peak Measure Level+ Duty Factor

Duty Factor= $20 \cdot \text{LOG}(\text{Pulse Number} \cdot \text{On Time}/100) = -31.06\text{dB}$ in worst condition in normal use.

Pulse Number

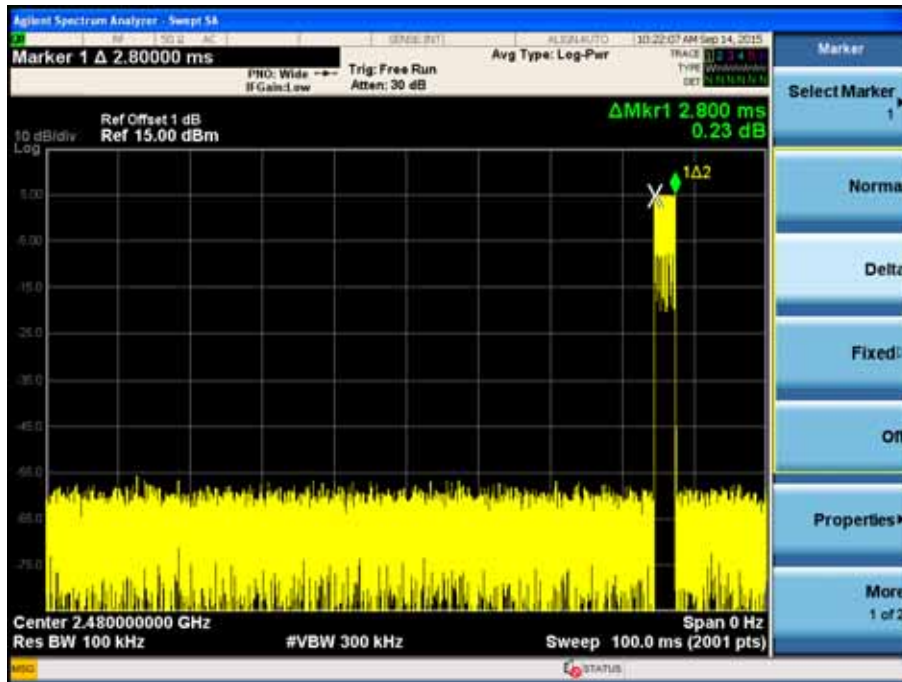

Engineer: Scott	
Site: AC5	Time: 2015/09/14 - 19:23
Limit: FCC_Part15.209_RE(3m)	Margin: 0
Probe: Horn_3117_00167055(1-18GHz)	Polarity: Horizontal
EUT: IP-STB	Power: AC 120V/60Hz
Note: Mode 1: Transmit at CH2402MHz by DH5	

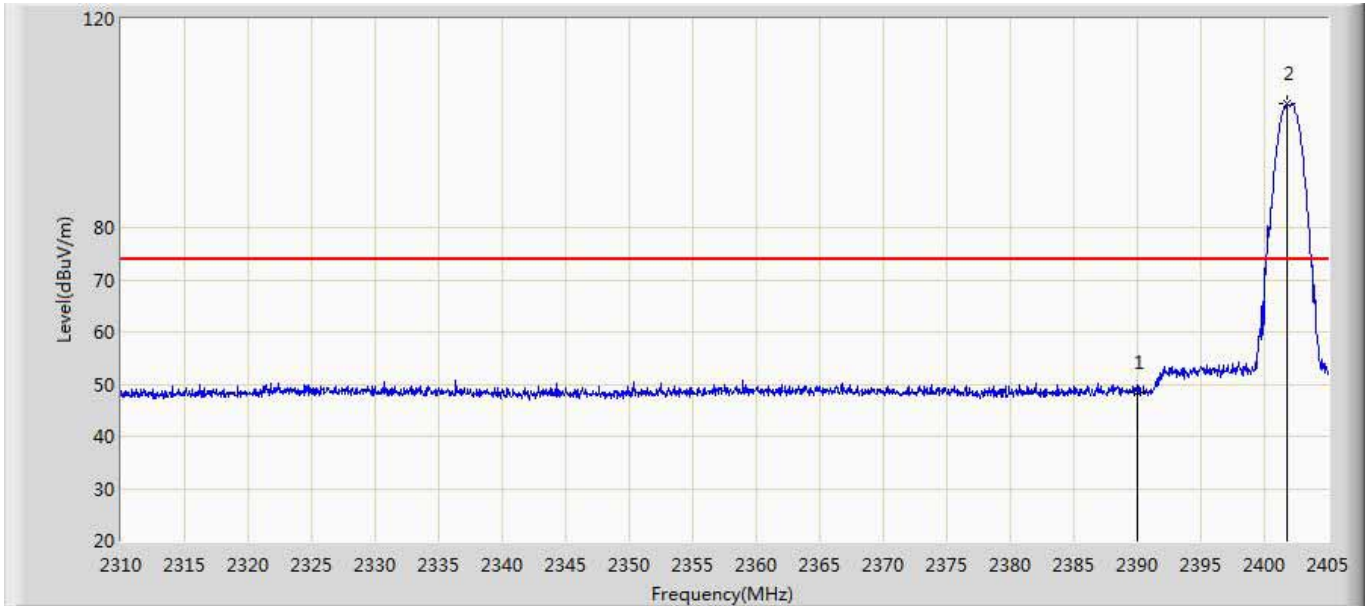

No	Mark	Frequency (MHz)	Measure Level (dBuV/m)	Reading Level (dBuV)	Over Limit (dB)	Limit (dBuV/m)	Factor (dB)	Type
1		2390.000	48.470	11.115	-25.530	74.000	37.355	PK
2	*	2401.817	103.646	66.304	N/A	N/A	37.342	PK

No	Mark	Frequency (MHz)	Peak Level (dBuV/m)	AV Level (dBuV)	Over Limit (dB)	Limit (dBuV/m)	Duty Factor (dB)	Type
1		2390.000	48.470	20.109	-33.891	54.000	-31.06	AV
3	*	2401.817	103.646	70.072	N/A	N/A	-31.06	AV

Engineer: Scott	
Site: AC5	Time: 2015/09/14 - 19:26
Limit: FCC_Part15.209_RE(3m)	Margin: 0
Probe: Horn_3117_00167055(1-18GHz)	Polarity: Vertical
EUT: IP-STB	Power: AC 120V/60Hz
Note: Mode 1: Transmit at CH2402MHz by DH5	

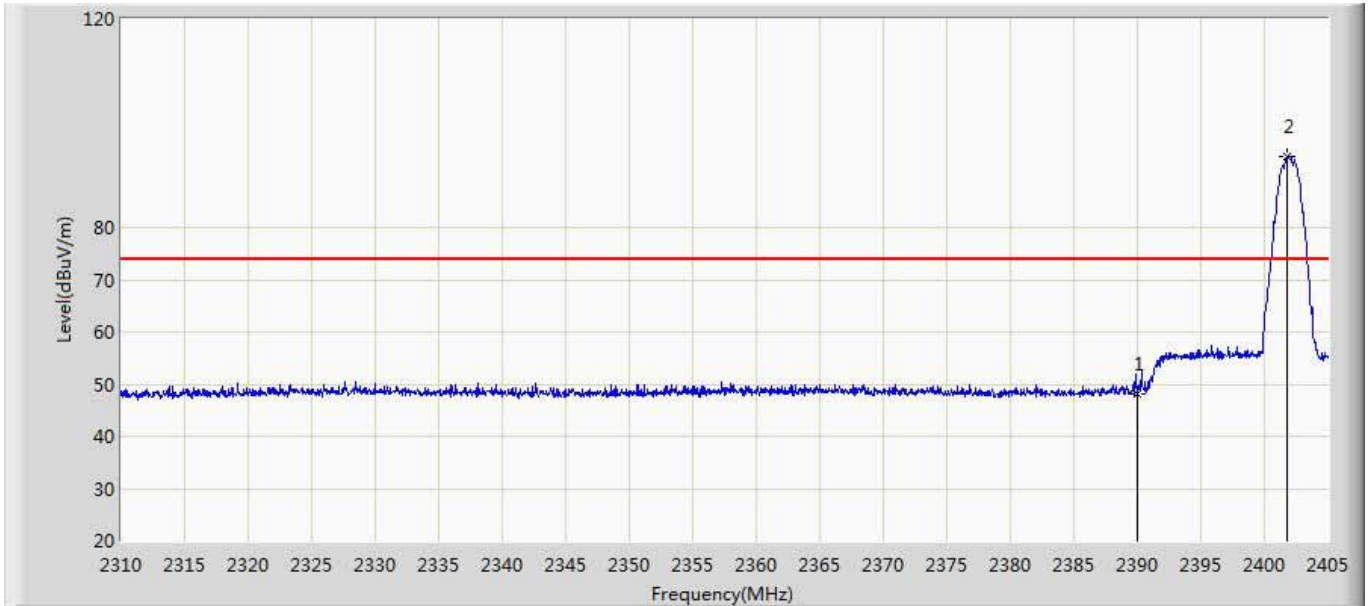

No	Mark	Frequency (MHz)	Measure Level (dBuV/m)	Reading Level (dBuV)	Over Limit (dB)	Limit (dBuV/m)	Factor (dB)	Type
1		2390.000	48.163	10.808	-25.837	74.000	37.355	PK
2	*	2401.770	93.480	56.138	N/A	N/A	37.342	PK

No	Mark	Frequency (MHz)	Peak Level (dBuV/m)	AV Level (dBuV)	Over Limit (dB)	Limit (dBuV/m)	Duty Factor (dB)	Type
1		2390.000	48.163	17.103	-36.897	54.000	-31.06	AV
3	*	2401.770	93.480	62.420	N/A	N/A	-31.06	AV

Engineer: Scott	
Site: AC5	Time: 2015/09/14 - 19:30
Limit: FCC_Part15.209_RE(3m)	Margin: 0
Probe: Horn_3117_00167055(1-18GHz)	Polarity: Horizontal
EUT: IP-STB	Power: AC 120V/60Hz
Note: Mode 1: Transmit at CH2480MHz by DH5	

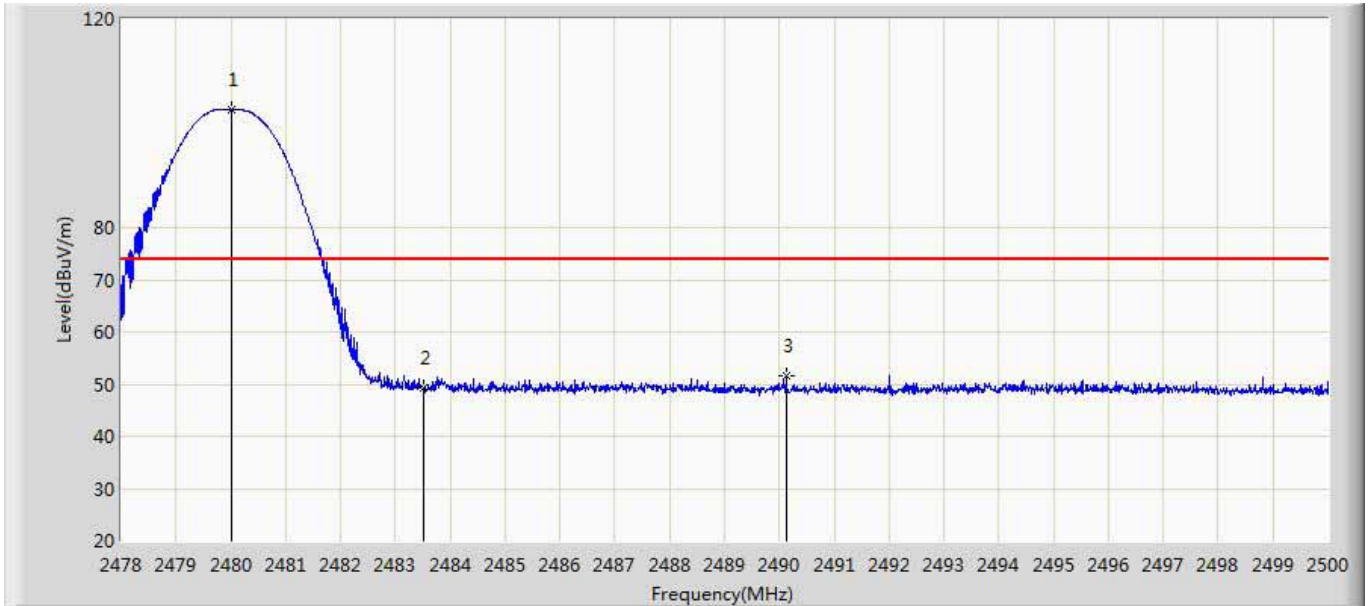

No	Mark	Frequency (MHz)	Measure Level (dBuV/m)	Reading Level (dBuV)	Over Limit (dB)	Limit (dBuV/m)	Factor (dB)	Type
1	*	2480.024	102.610	65.124	N/A	N/A	37.486	PK
2		2483.500	49.354	11.843	-24.646	74.000	37.511	PK
3		2490.122	51.622	14.063	-22.378	74.000	37.559	PK

No	Mark	Frequency (MHz)	Peak Level (dBuV/m)	AV Level (dBuV)	Over Limit (dB)	Limit (dBuV/m)	Duty Factor (dB)	Type
1	*	2480.024	102.610	71.550	N/A	N/A	-31.06	AV
2		2483.500	49.354	18.294	-35.706	54.000	-31.06	AV
3		2490.122	51.622	20.562	-33.438	74.000	-31.06	AV

Engineer: Scott	
Site: AC5	Time: 2015/09/14 - 19:35
Limit: FCC_Part15.209_RE(3m)	Margin: 0
Probe: Horn_3117_00167055(1-18GHz)	Polarity: Vertical
EUT: IP-STB	Power: AC 120V/60Hz
Note: Mode 1: Transmit at CH2480MHz by DH5	

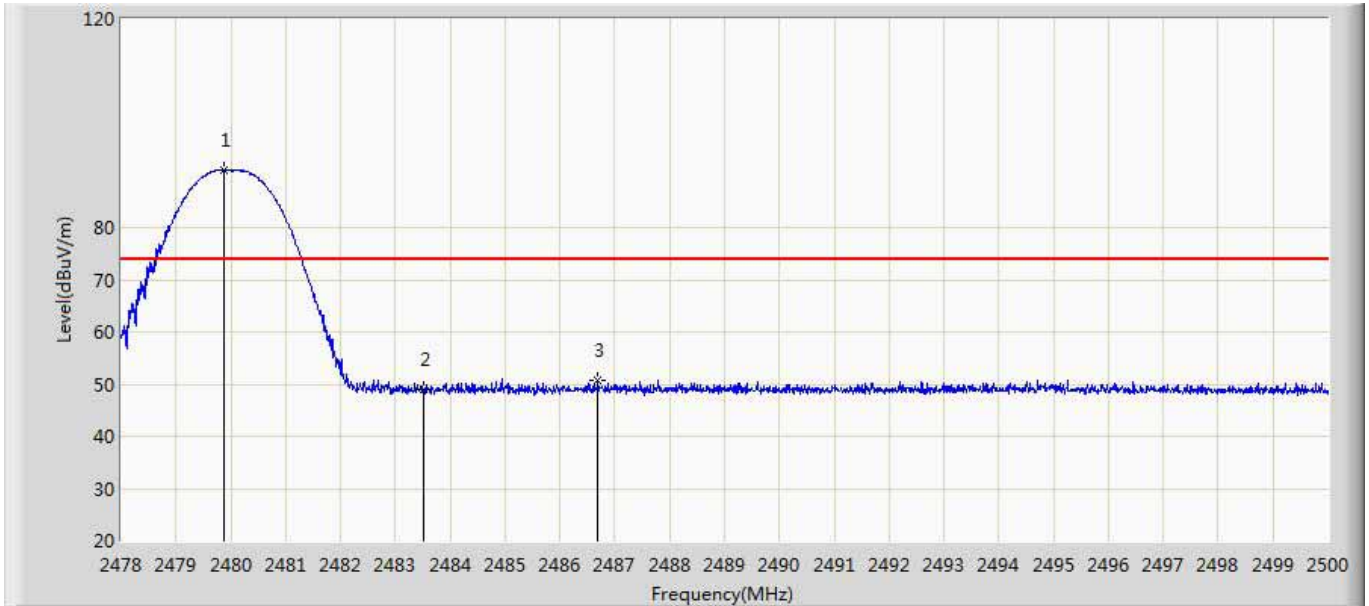

No	Mark	Frequency (MHz)	Measure Level (dBuV/m)	Reading Level (dBuV)	Over Limit (dB)	Limit (dBuV/m)	Factor (dB)	Type
1	*	2479.881	91.061	53.576	N/A	N/A	37.485	PK
2		2483.500	48.970	11.459	-25.030	74.000	37.511	PK
3		2486.690	50.645	13.111	-23.355	74.000	37.534	PK

No	Mark	Frequency (MHz)	Peak Level (dBuV/m)	AV Level (dBuV)	Over Limit (dB)	Limit (dBuV/m)	Duty Factor (dB)	Type
1	*	2479.881	91.061	60.001	N/A	N/A	-31.06	AV
2		2483.500	48.970	17.910	-36.090	54.000	-31.06	AV
3		2486.690	50.645	19.585	-34.415	54.000	-31.06	AV

Engineer: Scott	
Site: AC5	Time: 2015/09/14 - 19:37
Limit: FCC_Part15.209_RE(3m)	Margin: 0
Probe: Horn_3117_00167055(1-18GHz)	Polarity: Horizontal
EUT: IP-STB	Power: AC 120V/60Hz
Note: Mode 2: Transmit at CH2402MHz by 2DH5	

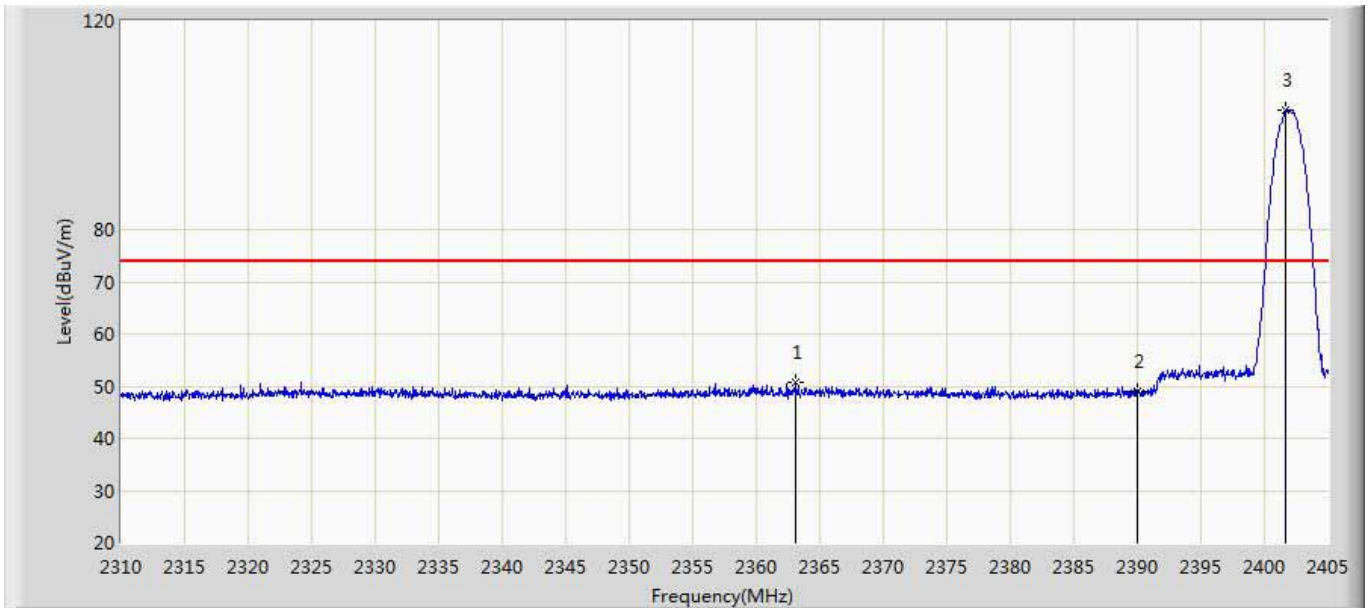

No	Mark	Frequency (MHz)	Measure Level (dBuV/m)	Reading Level (dBuV)	Over Limit (dB)	Limit (dBuV/m)	Factor (dB)	Type
1		2363.105	50.857	13.567	-23.143	74.000	37.291	PK
2		2390.000	49.074	11.719	-24.926	74.000	37.355	PK
3	*	2401.722	102.784	65.442	N/A	N/A	37.342	PK

No	Mark	Frequency (MHz)	Peak Level (dBuV/m)	AV Level (dBuV)	Over Limit (dB)	Limit (dBuV/m)	Duty Factor (dB)	Type
1		2363.105	50.857	19.797	-34.203	54.000	-31.06	AV
2		2390.000	49.074	18.014	-35.986	54.000	-31.06	AV
3	*	2401.722	102.784	71.724	N/A	N/A	-31.06	AV

Engineer: Scott	
Site: AC5	Time: 2015/09/14 - 19:39
Limit: FCC_Part15.209_RE(3m)	Margin: 0
Probe: Horn_3117_00167055(1-18GHz)	Polarity: Vertical
EUT: IP-STB	Power: AC 120V/60Hz
Note: Mode 2: Transmit at CH2402MHz by 2DH5	

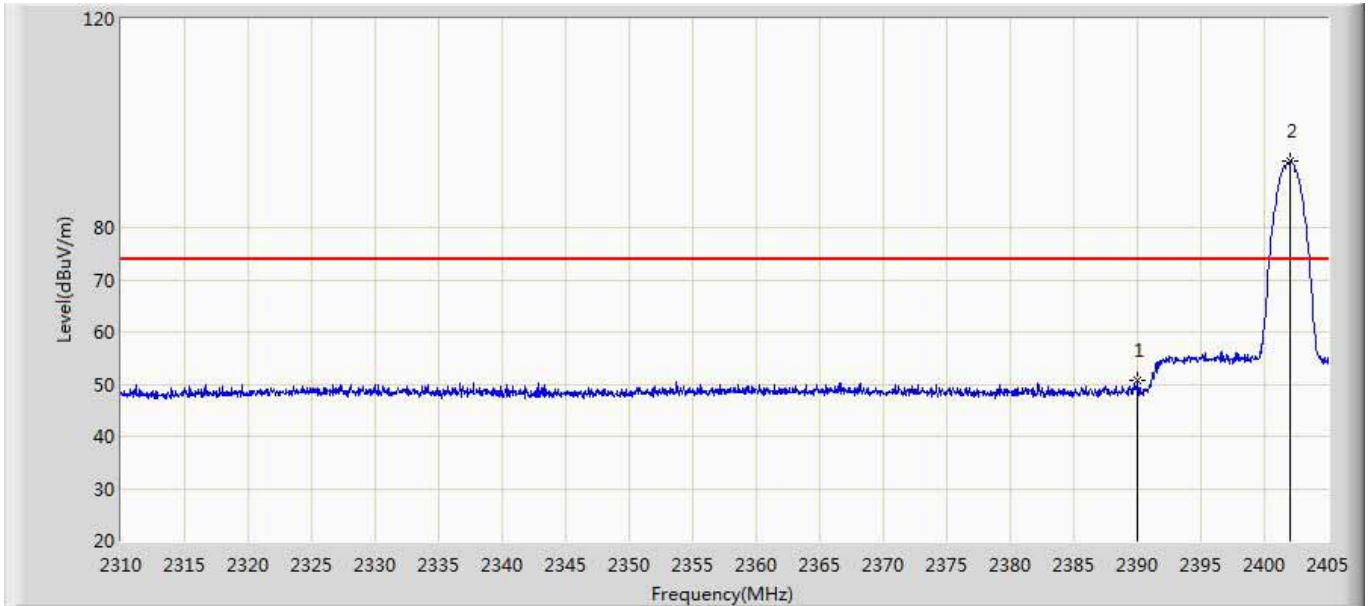

No	Mark	Frequency (MHz)	Measure Level (dBuV/m)	Reading Level (dBuV)	Over Limit (dB)	Limit (dBuV/m)	Factor (dB)	Type
1		2390.000	50.607	13.252	-23.393	74.000	37.355	PK
2	*	2402.055	92.651	55.309	N/A	N/A	37.341	PK

No	Mark	Frequency (MHz)	Peak Level (dBuV/m)	AV Level (dBuV)	Over Limit (dB)	Limit (dBuV/m)	Duty Factor (dB)	Type
1		2390.000	50.607	19.547	-34.453	54.000	-31.06	AV
3	*	2402.055	92.651	61.591	N/A	N/A	-31.06	AV

Engineer: Scott	
Site: AC5	Time: 2015/09/14 - 19:43
Limit: FCC_Part15.209_RE(3m)	Margin: 0
Probe: Horn_3117_00167055(1-18GHz)	Polarity: Horizontal
EUT: IP-STB	Power: AC 120V/60Hz
Note: Mode 2: Transmit at CH2480MHz by 2DH5	

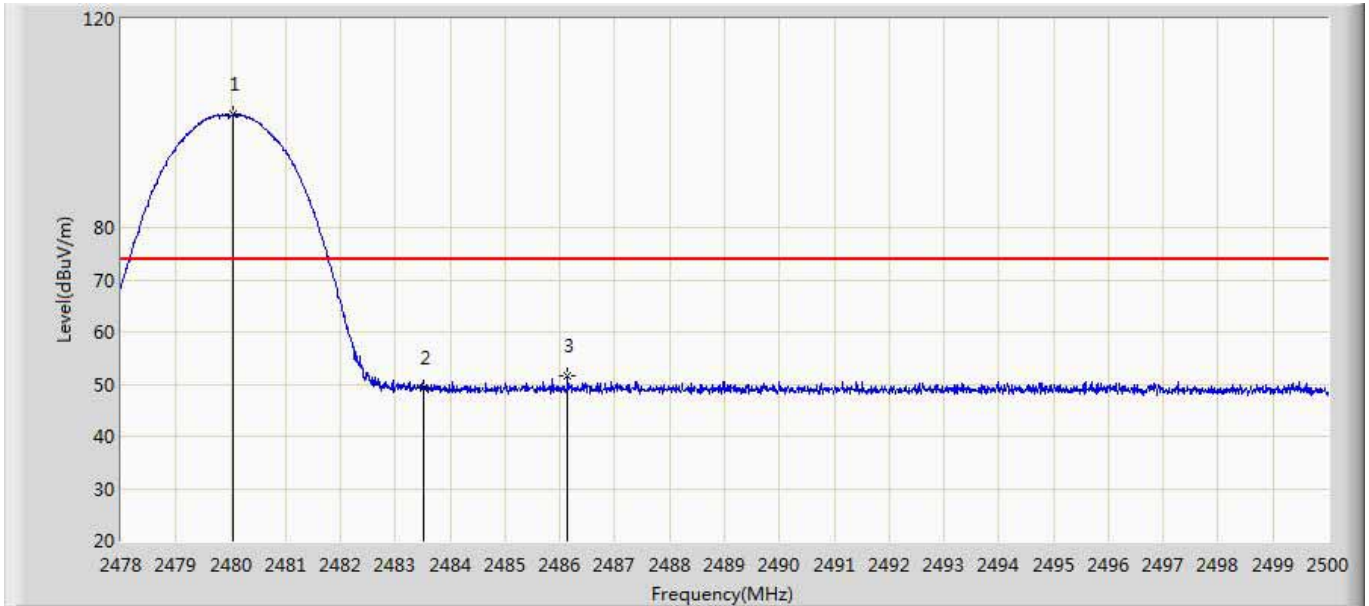

No	Mark	Frequency (MHz)	Measure Level (dBuV/m)	Reading Level (dBuV)	Over Limit (dB)	Limit (dBuV/m)	Factor (dB)	Type
1	*	2480.046	101.595	64.109	N/A	N/A	37.486	PK
2		2483.500	49.266	11.755	-24.734	74.000	37.511	PK
3		2486.140	51.577	14.047	-22.423	74.000	37.530	PK

No	Mark	Frequency (MHz)	Peak Level (dBuV/m)	AV Level (dBuV)	Over Limit (dB)	Limit (dBuV/m)	Duty Factor (dB)	Type
1	*	2480.046	101.595	70.535	N/A	N/A	-31.06	AV
2		2483.500	49.266	18.206	-35.794	54.000	-31.06	AV
3		2486.140	51.577	20.517	-33.483	54.000	-31.06	AV

Engineer: Scott	
Site: AC5	Time: 2015/09/14 - 19:45
Limit: FCC_Part15.209_RE(3m)	Margin: 0
Probe: Horn_3117_00167055(1-18GHz)	Polarity: Vertical
EUT: IP-STB	Power: AC 120V/60Hz
Note: Mode 2: Transmit at CH2480MHz by 2DH5	

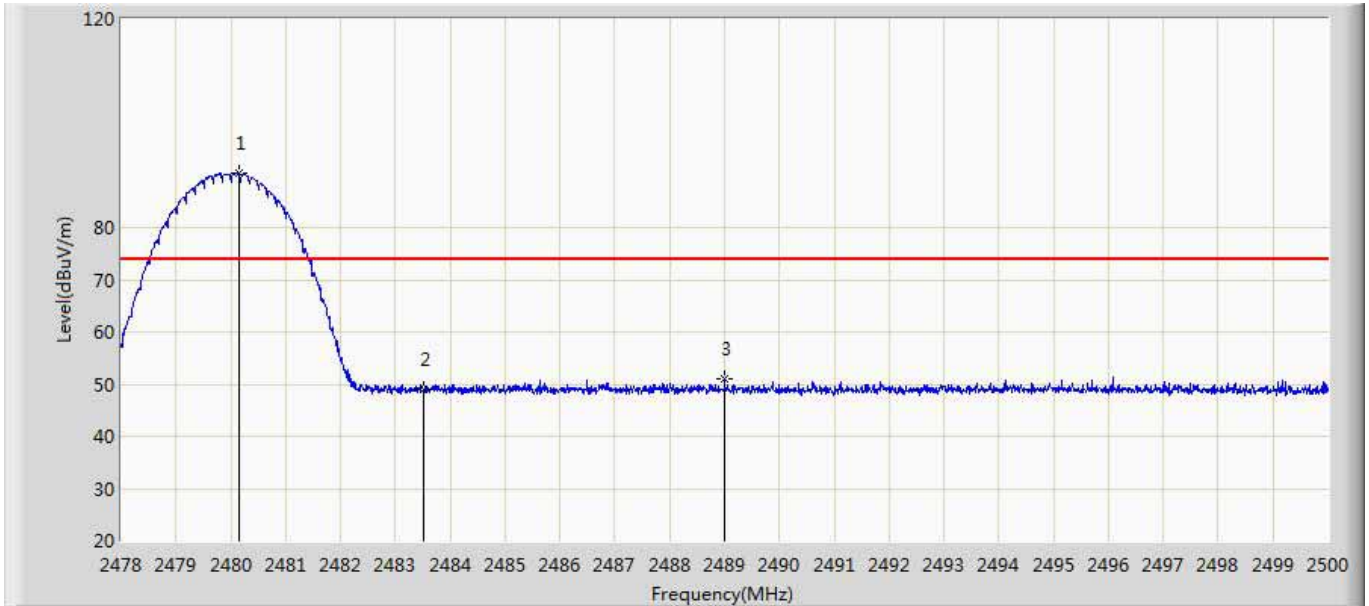

No	Mark	Frequency (MHz)	Measure Level (dBuV/m)	Reading Level (dBuV)	Over Limit (dB)	Limit (dBuV/m)	Factor (dB)	Type
1	*	2480.145	90.387	52.900	N/A	N/A	37.487	PK
2		2483.500	49.011	11.500	-24.989	74.000	37.511	PK
3		2489.000	51.074	13.523	-22.926	74.000	37.551	PK

No	Mark	Frequency (MHz)	Peak Level (dBuV/m)	AV Level (dBuV)	Over Limit (dB)	Limit (dBuV/m)	Duty Factor (dB)	Type
1	*	2480.145	90.387	59.327	N/A	N/A	-31.06	AV
2		2483.500	49.011	17.951	-36.049	54.000	-31.06	AV
3		2489.000	51.074	20.014	-33.986	54.000	-31.06	AV

Engineer: Scott	
Site: AC5	Time: 2015/09/14 - 19:47
Limit: FCC_Part15.209_RE(3m)	Margin: 0
Probe: Horn_3117_00167055(1-18GHz)	Polarity: Horizontal
EUT: IP-STB	Power: AC 120V/60Hz
Note: Mode 3: Transmit at CH2402MHz by 3DH5	

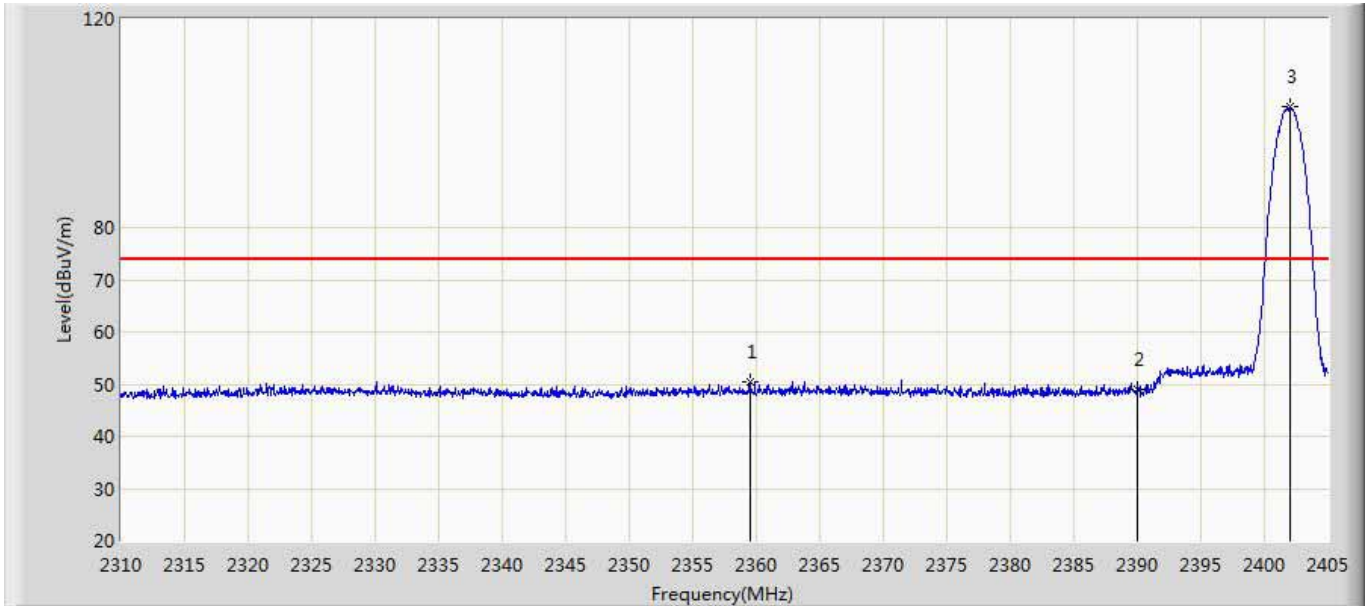

No	Mark	Frequency (MHz)	Measure Level (dBuV/m)	Reading Level (dBuV)	Over Limit (dB)	Limit (dBuV/m)	Factor (dB)	Type
1		2359.495	50.330	13.056	-23.670	74.000	37.273	PK
2		2390.000	48.861	11.506	-25.139	74.000	37.355	PK
3	*	2402.055	103.082	65.740	N/A	N/A	37.341	PK

No	Mark	Frequency (MHz)	Peak Level (dBuV/m)	AV Level (dBuV)	Over Limit (dB)	Limit (dBuV/m)	Duty Factor (dB)	Type
1		2359.495	50.330	19.270	-34.730	54.000	-31.06	AV
2		2390.000	48.861	17.801	-36.199	54.000	-31.06	AV
3	*	2402.055	103.082	72.022	N/A	N/A	-31.06	AV

Engineer: Scott	
Site: AC5	Time: 2015/09/14 - 19:49
Limit: FCC_Part15.209_RE(3m)	Margin: 0
Probe: Horn_3117_00167055(1-18GHz)	Polarity: Vertical
EUT: IP-STB	Power: AC 120V/60Hz
Note: Mode 3: Transmit at CH2402MHz by 3DH5	

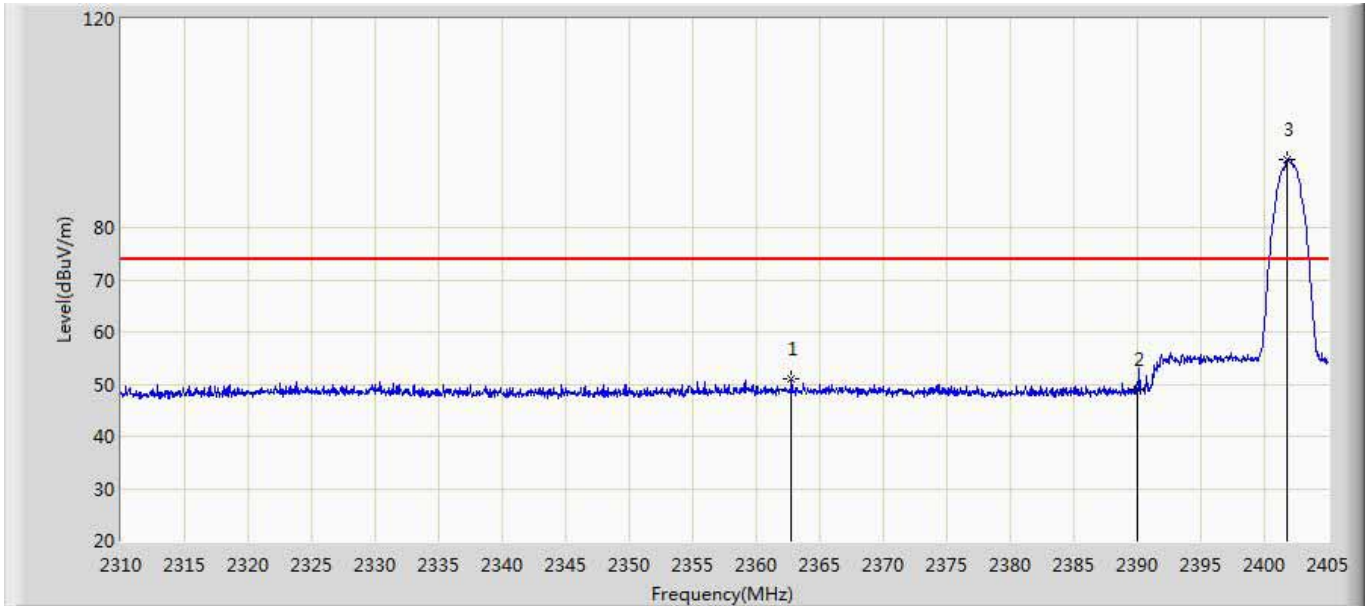

No	Mark	Frequency (MHz)	Measure Level (dBuV/m)	Reading Level (dBuV)	Over Limit (dB)	Limit (dBuV/m)	Factor (dB)	Type
1		2362.772	50.997	13.708	-23.003	74.000	37.288	PK
2		2390.000	48.858	11.503	-25.142	74.000	37.355	PK
3	*	2401.817	93.150	55.808	N/A	N/A	37.342	PK

No	Mark	Frequency (MHz)	Peak Level (dBuV/m)	AV Level (dBuV)	Over Limit (dB)	Limit (dBuV/m)	Duty Factor (dB)	Type
1		2362.772	50.997	19.937	-34.063	54.000	-31.06	AV
2		2390.000	48.858	17.798	-36.202	54.000	-31.06	AV
3	*	2401.817	93.150	62.090	N/A	N/A	-31.06	AV

Engineer: Scott	
Site: AC5	Time: 2015/09/14 - 19:52
Limit: FCC_Part15.209_RE(3m)	Margin: 0
Probe: Horn_3117_00167055(1-18GHz)	Polarity: Horizontal
EUT: IP-STB	Power: AC 120V/60Hz
Note: Mode 3: Transmit at CH2480MHz by 3DH5	

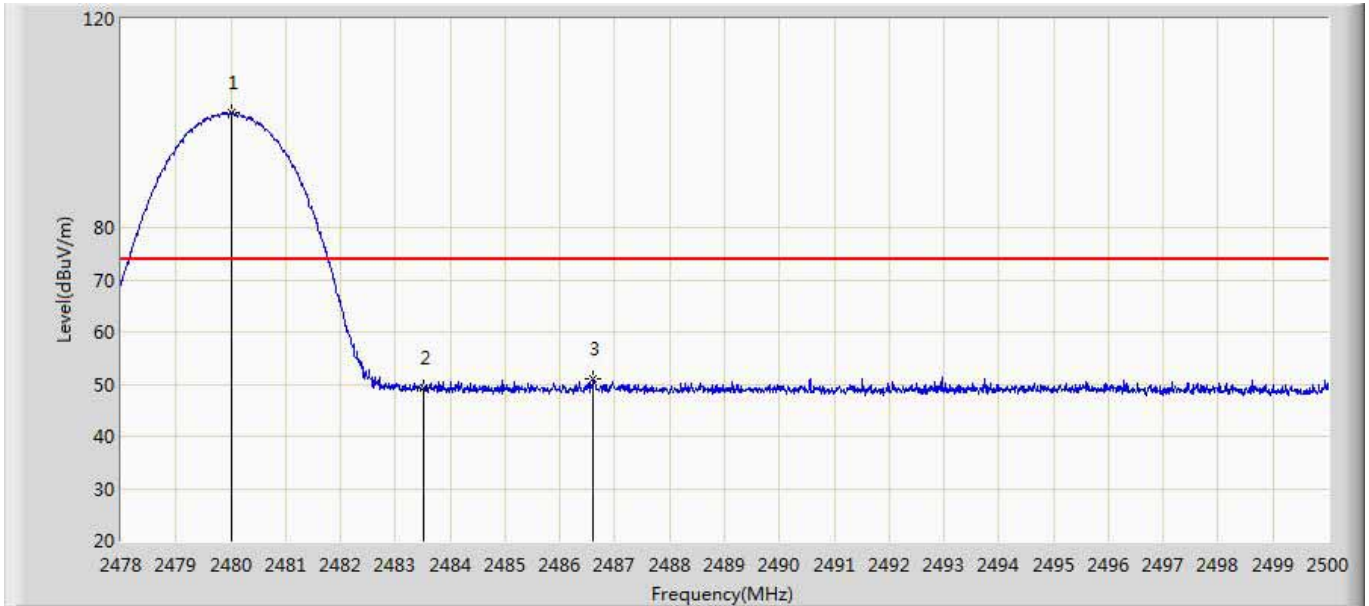

No	Mark	Frequency (MHz)	Measure Level (dBuV/m)	Reading Level (dBuV)	Over Limit (dB)	Limit (dBuV/m)	Factor (dB)	Type
1	*	2480.024	101.947	64.461	N/A	N/A	37.486	PK
2		2483.500	49.291	11.780	-24.709	74.000	37.511	PK
3		2486.613	50.975	13.441	-23.025	74.000	37.534	PK

No	Mark	Frequency (MHz)	Peak Level (dBuV/m)	AV Level (dBuV)	Over Limit (dB)	Limit (dBuV/m)	Duty Factor (dB)	Type
1	*	2480.024	101.947	70.887	N/A	N/A	-31.06	AV
2		2483.500	49.291	18.231	-35.769	54.000	-31.06	AV
3		2486.613	50.975	19.915	-34.085	54.000	-31.06	AV

Engineer: Scott	
Site: AC5	Time: 2015/09/14 - 19:53
Limit: FCC_Part15.209_RE(3m)	Margin: 0
Probe: Horn_3117_00167055(1-18GHz)	Polarity: Vertical
EUT: IP-STB	Power: AC 120V/60Hz
Note: Mode 3: Transmit at CH2480MHz by 3DH5	

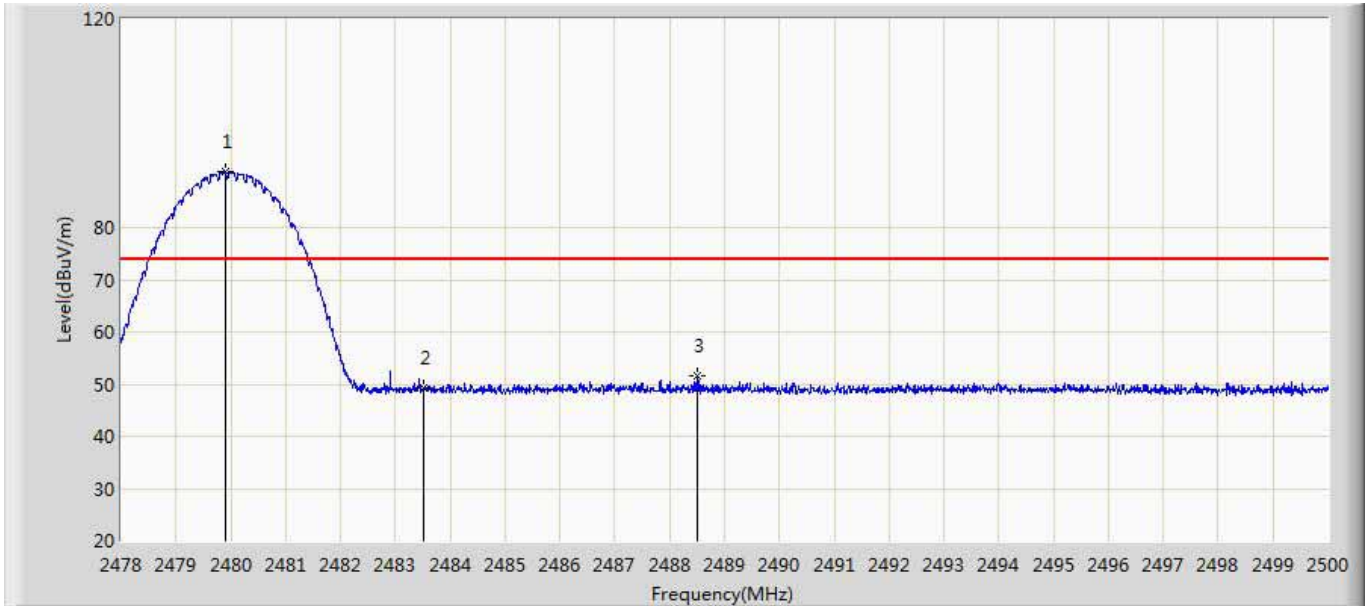

No	Mark	Frequency (MHz)	Measure Level (dBuV/m)	Reading Level (dBuV)	Over Limit (dB)	Limit (dBuV/m)	Factor (dB)	Type
1	*	2479.903	90.684	53.199	N/A	N/A	37.485	PK
2		2483.500	49.413	11.902	-24.587	74.000	37.511	PK
3		2488.516	51.601	14.054	-22.399	74.000	37.547	PK

No	Mark	Frequency (MHz)	Peak Level (dBuV/m)	AV Level (dBuV)	Over Limit (dB)	Limit (dBuV/m)	Duty Factor (dB)	Type
1	*	2479.903	90.684	59.624	N/A	N/A	-31.06	AV
2		2483.500	49.413	18.353	-35.647	54.000	-31.06	AV
3		2488.516	51.601	20.541	-33.459	54.000	-31.06	AV

————— The End —————