

SAR Test Report

Product Name : IP-STB
Model No. : 3500X
FCC ID : TC2-R1008

Applicant : Roku Inc.

Address : 12980 Saratoga Ave, Suite D Saratoga, CA 95070

Date of Receipt : Jan. 23, 2014
Test Date : Mar. 10, 2014
Issued Date : Mar. 10, 2014
Report No. : 1410471R-HP-US-P03V01
Report Version : V1.0



The test results relate only to the samples tested.

The test report shall not be reproduced except in full without the written approval of QuieTek Corporation.

Test Report Certification

Issued Date: Mar. 10, 2014

Report No: 1410471R-HP-US-P03V01



Product Name : IP-STB

Applicant : Roku Inc.

Address : 12980 Saratoga Ave, Suite D Saratoga, CA 95070

Manufacturer : Ambit Mircosystems (Shanghai) LTD.

Address : 1925, Nanle Road, Songjiang Export Processing Zone, Shanghai, China 201613

FCC ID : TC2-R1008

Model No. : 3500X

Brand Name : Roku

EUT Voltage : 5V

Applicable Standard : FCC KDB Publication 248227 D01v02
 FCC KDB Publication 447498 D01v05r02
 FCC KDB Publication 447498 D02v02
 FCC KDB Publication 865664 D01v01r03

Test Result : Max. SAR Measurement (1g)
 802.11b (2.4GHz): 0.414 W/kg
 802.11a (5GHz): 1.28 W/kg

Performed Location : Suzhou EMC Laboratory
 No.99 Hongye Rd., Suzhou Industrial Park Loufeng Hi-Tech Development Zone., Suzhou, China
 TEL: +86-512-6251-5088 / FAX: +86-512-6251-5098
 FCC Registration Number: 800392

Documented By : Alice Ni

Reviewed By : Jame Yuan

Approved By : Jeff Chen

Laboratory Information

We, **Quietek Corporation**, are an independent EMC and safety consultancy that was established the whole facility in our laboratories. The test facility has been accredited/accepted(audited or listed) by the following related bodies in compliance with ISO 17025, EN 45001 and specified testing scope:

Taiwan R.O.C.	:	BSMI, NCC, TAF
Germany	:	TUV Rheinland
Norway	:	Nemko, DNV
USA	:	FCC, NVLAP
Japan	:	VCCI
China	:	CNAS

The related certificate for our laboratories about the test site and management system can be downloaded from Quietek Corporation's Web Site :<http://www.quietek.com/tw/ctg/cts/accreditations.htm>

The address and introduction of Quietek Corporation's laboratories can be founded in our Web site :
<http://www.quietek.com/>

If you have any comments, Please don't hesitate to contact us. Our contact information is as below:

HsinChu Testing Laboratory :

No.75-2, 3rd Lin, Wangye Keng, Yonghxing Tsuen, Qionglin Shiang, Hsinchu County 307, Taiwan, R.O.C.
TEL:+886-3-592-8858 / FAX:+886-3-592-8859 E-Mail : service@quietek.com

LinKou Testing Laboratory :

No.5-22, Ruishukeng, Linkou Dist., New Taipei City 24451, Taiwan, R.O.C.
TEL : 886-2-8601-3788 / FAX : 886-2-8601-3789 E-Mail : service@quietek.com

Suzhou Testing Laboratory :

No.99 Hongye Rd., Suzhou Industrial Park Loufeng Hi-Tech Development Zone., SuZhou, China
TEL : +86-512-6251-5088 / FAX : 86-512-6251-5098 E-Mail : service@quietek.com

TABLE OF CONTENTS

Description	Page
1. General Information	6
1.1. EUT Description	6
1.2. Test Environment.....	7
2. SAR Measurement System	11
2.1. DASY5 System Description.....	11
2.1.1. Applications	12
2.1.2. Area Scans	12
2.1.3. Zoom Scan (Cube Scan Averaging)	12
2.1.4. Uncertainty of Inter-/Extrapolation and Averaging	12
2.2. DASY5 E-Field Probe.....	13
2.2.1. Isotropic E-Field Probe Specification	13
2.3. Boundary Detection Unit and Probe Mounting Device	14
2.4. DATA Acquisition Electronics (DAE) and Measurement Server	14
2.5. Robot.....	15
2.6. Light Beam Unit.....	15
2.7. Device Holder.....	16
2.8. SAM Twin Phantom.....	16
3. Tissue Simulating Liquid	17
3.1. The composition of the tissue simulating liquid	17
3.2. Tissue Calibration Result.....	17
3.3. Tissue Dielectric Parameters for Head and Body Phantoms	18
4. SAR Measurement Procedure	19
4.1. SAR System Validation.....	19
4.1.1. Validation Dipoles	19
4.1.2. Validation Result	19
4.2. SAR Measurement Procedure.....	21
5. SAR Exposure Limits.....	22
6. Test Equipment List	23
7. Measurement Uncertainty.....	27
8. Conducted Power Measurement	29
9. Test Procedures.....	33

9.1. Test position and configuration37

9.2. SAR Test Results Summary33

Appendix A. SAR System Validation Data37

Appendix B. SAR measurement Data.....40

Appendix C. Test Setup Photographs & EUT Photographs84

Appendix D. Probe Calibration Data84

Appendix E. Dipole Calibration Data.....95

Appendix F. DAE Calibration Data 117

1. General Information

1.1. EUT Description

Product Name	IP-STB
Brand Name	Roku
Model No.	3500X
EUT Voltage	100-240Vac +/-10%
Frequency Range	For 2.4GHz Band 802.11b/g/n(20MHz): 2412~2462MHz 802.11n(40MHz): 2422~2452MHz For 5.0GHz Band 802.11a/n(20MHz): 5180~5240MHz, 5745~5825MHz 802.11n(40MHz): 5190~5230MHz, 5755~5795MHz
Channel Number	For 2.4GHz Band 802.11b/g/n(20MHz): 11 802.11n(40MHz): 7 For 5.0GHz Band 802.11a /n(20MHz): 9 802.11n(40MHz): 4
Type of Modulation	802.11b: DSSS 802.11a/g/n: OFDM
Data Rate	802.11a/g: 6/9/12/18/24/36/48/54 Mbps 802.11b: 1/2/5.5/11 Mbps 802.11n: up to 300 Mbps
Channel Control	Auto
Antenna Delivery	2*Tx + 2*Rx
Antenna Type	Printed Antenna
Peak Antenna Gain	2dBi for 2.4GHz and 5GHz

For 2.4GHz Band

802.11b/g/n(20MHz) Working Frequency of Each Channel:							
Channel	Frequency	Channel	Frequency	Channel	Frequency	Channel	Frequency
01	2412 MHz	02	2417 MHz	03	2422 MHz	04	2427 MHz
05	2432 MHz	06	2437 MHz	07	2442 MHz	08	2447 MHz
09	2452 MHz	10	2457 MHz	11	2462 MHz	N/A	N/A
802.11n(40MHz) Working Frequency of Each Channel:							
Channel	Frequency	Channel	Frequency	Channel	Frequency	Channel	Frequency
03	2422 MHz	04	2427 MHz	05	2432 MHz	06	2437 MHz
07	2442 MHz	08	2447 MHz	09	2452 MHz	N/A	N/A

For 5.0GHz Band

802.11a/n(20MHz) Working Frequency of Each Channel:							
Channel	Frequency	Channel	Frequency	Channel	Frequency	Channel	Frequency
36	5180 MHz	40	5200 MHz	44	5220 MHz	48	5240 MHz
149	5745 MHz	153	5765 MHz	157	5785 MHz	161	5805 MHz
165	5825 MHz	N/A	N/A	N/A	N/A	N/A	N/A
802.11n(40MHz) Working Frequency of Each Channel:							
Channel	Frequency	Channel	Frequency	Channel	Frequency	Channel	Frequency
38	5190 MHz	46	5230 MHz	151	5755 MHz	159	5795 MHz

Power Parameter Value of the test software

Test Mode	Test Channel	Ant0	Ant1	Ant0+1
802.11b	2412	74	78	×
	2437	66	70	×
	2462	70	66	×
802.11g	2412	70	74	×
	2437	72	84	×
	2462	64	68	×
802.11n(20MHz)	2412	58	74	58
	2437	84	76	84
	2462	56	60	58
802.11n(40MHz)	2422	52	60	46
	2437	84	75	70
	2452	52	54	50

Test Mode	Test Channel	Ant0	Ant1	Ant0+1
802.11a	5745	60	64	×
	5785	66	66	×
	5825	66	66	×
802.11n (20MHz)	5745	48	48	48
	5785	66	70	52
	5825	48	48	40
802.11n (40MHz)	5755	48	48	48
	5795	48	48	48

The test mode of the test software can support.

Test Mode	Ant0	Ant1	Ant0+1
802.11b			×
802.11g			×
802.11a			
802.11n(20MHz)			
802.11n(40MHz)			

1.2. Test Environment

Ambient conditions in the laboratory:

Items	Required	Actual
Temperature (°C)	18-25	21.5± 2
Humidity (%RH)	30-70	52

1.3. Simultaneous Transmission Configurations

2.4GHz Wi-Fi and 5G Wi-Fi share the same antenna path and cannot transmit simultaneously.

1.4. Power Reduction for SAR

There is no power reduction used for any band/mode implemented in this device for SAR purposes.

1.5. Guidance Documents

- 1) FCC KDB Publication 447498 D01v05r02 (General SAR Guidance)
- 2) FCC KDB Publication 447498 D02v02 (SAR Measurement Procedures for USB Dongle Transmitters)
- 3) FCC KDB Publication 865664 D01v01r03(SAR measurement 100 MHz to 6 GHz)
- 4) FCC KDB Publication 248227 D01v01r02 (SAR Considerations for 802.11 Devices)

2. SAR Measurement System

2.1. DASY5 System Description

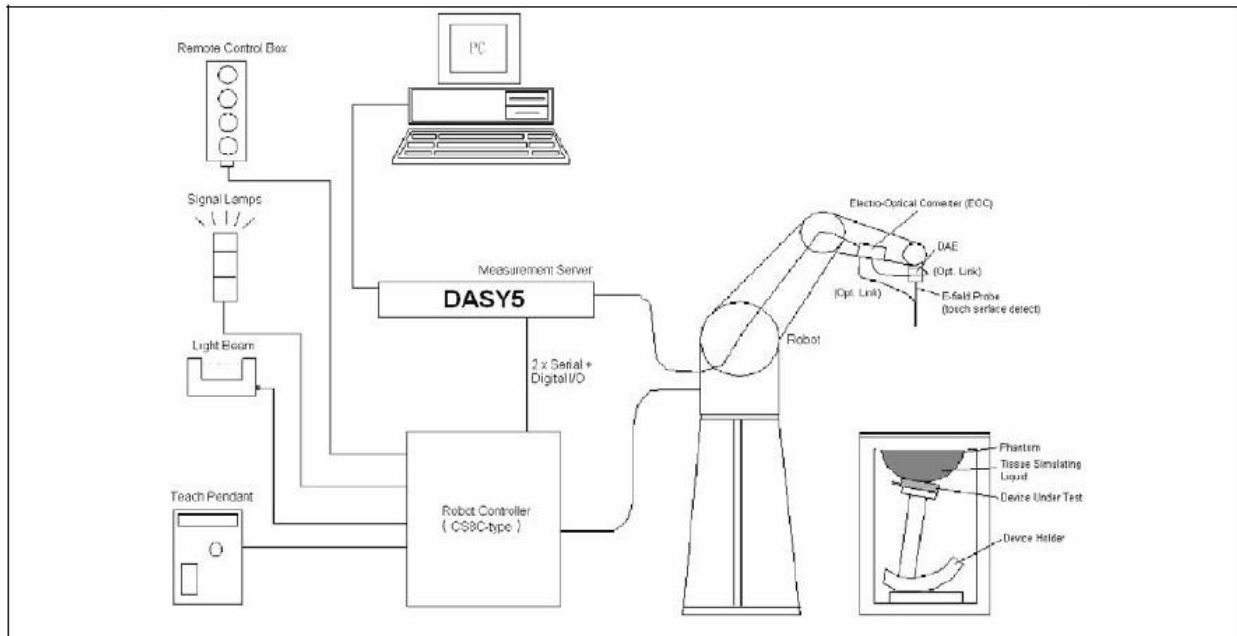

The DASY5 system for performing compliance tests consists of the following items:

- A standard high precision 6-axis robot with controller, teach pendant and software. An arm extension for accommodating the data acquisition electronics (DAE).
- A data acquisition electronics (DAE) which performs the signal amplification, signal multiplexing, AD-conversion, offset measurements, mechanical surface detection, collision detection, etc. The unit is battery powered with standard or rechargeable batteries. The signal is optically transmitted to the EOC.
- The Electro-optical converter (EOC) performs the conversion from optical to electrical signals for the digital communication to the DAE. To use optical surface detection, a special version of the EOC is required. The EOC signal is transmitted to the measurement server.
- The Light Beam used is for probe alignment. This improves the (absolute) accuracy of the probe positioning.
- A computer running WinXP and the DASY5 software.
- Remote control and teach pendant as well as additional circuitry for robot safety such as warning lamps, etc.
- The phantom, the device holder and other accessories according to the targeted measurement.

2.1.1. Applications

Predefined procedures and evaluations for automated compliance testing with all worldwide standards, e.g., IEEE 1528, OET 65, IEC 62209-1, IEC 62209-2, EN 50360, EN 50383 and others.

2.1.2. Area Scans

Area scans are defined prior to the measurement process being executed with a user defined variable spacing between each measurement point (integral) allowing low uncertainty measurements to be conducted. Scans defined for FCC applications utilize a 10mm² step integral, with 1mm interpolation used to locate the peak SAR area used for zoom scan assessments.

When an Area Scan has measured all reachable points, it computes the field maxima found in the scanned area, within a range of the global maximum. The range (in dB) is specified in the standards for compliance testing. For example, a 2 dB range is required in IEEE 1528-2003, EN 50361 and IEC 62209 standards, whereby 3 dB is a requirement when compliance is assessed in accordance with the ARIB standard (Japan).

2.1.3. Zoom Scan (Cube Scan Averaging)

Zoom Scans are used to assess the peak spatial SAR values within a cubic averaging volume containing 1 g and 10 g of simulated tissue. A density of 1000 kg/m³ is used to represent the head and body tissue density and not the phantom liquid density, in order to be consistent with the definition of the liquid dielectric properties, i.e. the side length of the 1 g cube is 10mm, with the side length of the 10 g cube 21,5mm.

The zoom scan integer steps can be user defined so as to reduce uncertainty, but normal practice for typical test applications utilize a physical step of 7x7x7 (5mmx5mmx5mm) providing a volume of 30mm in the X & Y axis, and 30mm in the Z axis.

2.1.4. Uncertainty of Inter-/Extrapolation and Averaging

In order to evaluate the uncertainty of the interpolation, extrapolation and averaged SAR calculation algorithms of the Postprocessor, DASY5 allows the generation of measurement grids which are artificially predefined by analytically based test functions. Therefore, the grids of area scans and zoom scans can be filled with uncertainty test data, according to the SAR benchmark functions of IEEE 1528. The three analytical functions shown in equations as below are used to describe the possible range of the expected SAR distributions for the tested handsets. The field gradients are covered by the spatially flat distribution f1, the spatially steep distribution f3 and f2 accounts for H-field cancellation on the phantom/tissue surface.

$$f_1(x, y, z) = Ae^{-\frac{z}{2a}} \cos^2 \left(\frac{\pi \sqrt{x'^2 + y'^2}}{2 \cdot 5a} \right)$$

$$f_2(x, y, z) = Ae^{-\frac{z}{a}} \frac{a^2}{a^2 + x'^2} \left(3 - e^{-\frac{2z}{a}} \right) \cos^2 \left(\frac{\pi y'}{2 \cdot 3a} \right)$$

$$f_3(x, y, z) = A \frac{a^2}{\frac{a^2}{4} + x'^2 + y'^2} \left(e^{-\frac{2z}{a}} + \frac{a^2}{2(a + 2z)^2} \right)$$

2.2. DASYS E-Field Probe

The SAR measurement is conducted with the dosimetric probe manufactured by SPEAG. The probe is specially designed and calibrated for use in liquid with high permittivity. The dosimetric probe has special calibration in liquid at different frequency. SPEAG conducts the probe calibration in compliance with international and national standards (e.g. IEEE 1528, EN 62209-1, IEC 62209, etc.) under ISO 17025. The calibration data are in Appendix D.

2.2.1. Isotropic E-Field Probe Specification

Model	EX3DV4	
Construction	Symmetrical design with triangular core Built-in shielding against static charges PEEK enclosure material (resistant to organic solvents, e.g., DGBE)	
Frequency	10 MHz to 6 GHz Linearity: ± 0.2 dB (30 MHz to 6 GHz)	
Directivity	± 0.3 dB in HSL (rotation around probe axis) ± 0.5 dB in tissue material (rotation normal to probe axis)	
Dynamic Range	10 µW/g to 100 mW/g Linearity: ± 0.2 dB (noise: typically < 1 µW/g)	
Dimensions	Overall length: 330 mm (Tip: 20 mm) Tip diameter: 2.5 mm (Body: 12 mm) Typical distance from probe tip to dipole centers: 1 mm	
Application	High precision dosimetric measurements in any exposure scenario (e.g., very strong gradient fields). Only probe which enables compliance testing for frequencies up to 6 GHz with precision of better 30%.	

2.3. Boundary Detection Unit and Probe Mounting Device

The DASY probes use a precise connector and an additional holder for the probe, consisting of a plastic tube and a flexible silicon ring to center the probe. The connector at the DAE is flexibly mounted and held in the default position with magnets and springs. Two switching systems in the connector mount detect frontal and lateral probe collisions and trigger the necessary software response.

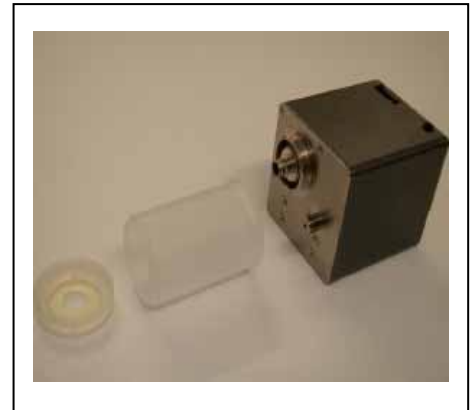

2.4. DATA Acquisition Electronics (DAE) and Measurement Server

The data acquisition electronics (DAE) consists of a highly sensitive electrometer-grade preamplifier with auto-zeroing, a channel and gain-switching multiplexer, a fast 16 bit AD-converter and a command decoder and control logic unit.



Transmission to the measurement server is accomplished through an optical downlink for data and status information as well as an optical uplink for commands and the clock.

The input impedance of the DAE4 is 200M Ohm; the inputs are symmetrical and floating. Common mode rejection is above 80dB.

The DASY5 measurement server is based on a PC/104 CPU board with a 400MHz intel ULV Celeron, 128MB chipdisk and 128MB RAM. The necessary circuits for communication with the DAE electronics box, as well as the 16 bit AD converter system for optical detection and digital I/O interface are contained on the DASY5 I/O board, which is directly connected to the PC/104 bus of the CPU board.



2.5. Robot

The DASY5 system uses the high precision robots TX90 XL type out of the newer series from Stäubli SA (France). For the 6-axis controller DASY5 system, the CS8C robot controller version from Stäubli is used.

The XL robot series have many features that are important for our application:

- High precision (repeatability 0.02 mm)
- High reliability (industrial design)
- Jerk-free straight movements
- Low ELF interference (the closed metallic construction shields against motor control fields)
- 6-axis controller



2.6. Light Beam Unit

The light beam switch allows automatic "tooling" of the probe. During the process, the actual position of the probe tip with respect to the robot arm is measured, as well as the probe length and the horizontal probe offset. The software then corrects all movements, such that the robot coordinates are valid for the probe tip.

The repeatability of this process is better than 0.1 mm. If a position has been taught with an aligned probe, the same position will be reached with another aligned probe within 0.1 mm, even if the other probe has different dimensions. During probe rotations, the probe tip will keep its actual position.



2.7. Device Holder

The DASY5 device holder is designed to cope with different positions given in the standard. It has two scales for the device rotation (with respect to the body axis) and the device inclination (with respect to the line between the ear reference points). The rotation center for both scales is the ear reference point (EPR).

Thus the device needs no repositioning when changing the angles.

The DASY5 device holder has been made out of low-loss POM material having the following dielectric parameters: relative permittivity $\epsilon_r = 3$ and loss tangent $\delta = 0.02$. The amount of dielectric material has been reduced in the closest vicinity of the device, since measurements have suggested that the influence of the clamp on the test results could thus be lowered.



2.8. SAM Twin Phantom

The SAM twin phantom is a fiberglass shell phantom with 2mm shell thickness (except the ear region where shell thickness increases to 6mm). It has three measurement areas:

- Left head
- Right head
- Flat phantom



The bottom plate contains three pair of bolts for locking the device holder. The device holder positions are adjusted to the standard measurement positions in the three sections. A white cover is provided to tap the phantom during off-periods to prevent water evaporation and changes in the liquid parameters. On the phantom tip, three reference markers are provided to identify the phantom position with respect to the robot.

3. Tissue Simulating Liquid

3.1. The composition of the tissue simulating liquid

INGREDIENT (% Weight)	2450MHz Body	5200MHz Body	5800MHz Body
Water	73.2	75.68	75.68
Salt	0.04	0.43	0.43
Sugar	0.00	0.00	0.00
HEC	0.00	0.00	0.00
Preventol	0.00	0.00	0.00
DGBE	26.7	4.42	4.42
Triton X-100	0.00	19.47	19.47

3.2. Tissue Calibration Result

The dielectric parameters of the liquids were verified prior to the SAR evaluation using DASYS5 Dielectric Probe Kit and Agilent Vector Network Analyzer E5071C

Body Tissue Simulant Measurement				
Frequency [MHz]	Description	Dielectric Parameters		Tissue Temp. [°C]
		ϵ_r	σ [s/m]	
2450MHz	Reference result ± 5% window	52.7 50.07 to 55.34	1.95 1.85 to 2.05	N/A
	10-03-2014	52.25	1.99	21.0
5200MHz	Reference result ± 5% window	49.0 46.55 to 51.45	5.30 5.04 to 5.57	N/A
	10-03-2014	48.94	5.15	21.0
5800MHz	Reference result ± 5% window	48.2 45.79 to 50.61	6.00 5.70 to 6.30	N/A
	10-03-2014	47.29	6.04	21.0

3.3. Tissue Dielectric Parameters for Head and Body Phantoms

The head tissue dielectric parameters recommended by the IEEE SCC-34/SC-2 in P1528 have been incorporated in the following table. These head parameters are derived from planar layer models simulating the highest expected SAR for the dielectric properties and tissue thickness variations in a human head. Other head and body tissue parameters that have not been specified in P1528 are derived from the tissue dielectric parameters computed from the 4-Cole-Cole equations described in Reference [12] and extrapolated according to the head parameters specified in P1528.

Target Frequency (MHz)	Head		Body	
	ϵ_r	σ (S/m)	ϵ_r	σ (S/m)
150	52.3	0.76	61.9	0.80
300	45.3	0.87	58.2	0.92
450	43.5	0.87	56.7	0.94
835	41.5	0.90	55.2	0.97
900	41.5	0.97	55.0	1.05
915	41.5	0.98	55.0	1.06
1450	40.5	1.20	54.0	1.30
1610	40.3	1.29	53.8	1.40
1800 – 2000	40.0	1.40	53.3	1.52
2450	39.2	1.80	52.7	1.95
3000	38.5	2.40	52.0	2.73
5800	35.3	5.27	48.2	6.00

(ϵ_r = relative permittivity, σ = conductivity and $\rho = 1000 \text{ kg/m}^3$)

4. SAR Measurement Procedure

4.1. SAR System Validation

4.1.1. Validation Dipoles

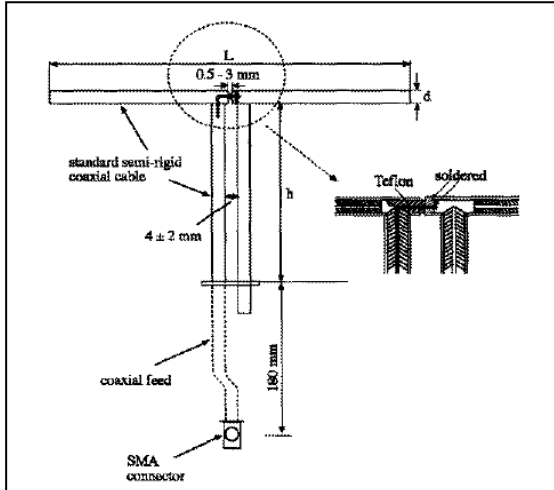

The dipoles used is based on the IEEE-1528 standard, and is complied with mechanical and electrical specifications in line with the requirements of both IEEE and FCC Supplement C. the table below provides details for the mechanical and electrical specifications for the dipoles.

Frequency	L (mm)	h (mm)	d (mm)
2450MHz	53.5	30.4	3.6
5800MHz	20.6	14.2	3.6

4.1.2. Validation Result

System Performance Check at 2450MHz				
Validation Dipole: D2450V2, SN: 839				
Frequency [MHz]	Description	SAR [w/kg] 1g	SAR [w/kg] 10g	Tissue Temp. [°C]
2450 MHz	Reference result ± 10% window	48.7 43.83 to 53.57	22.8 20.52 to 25.08	N/A
	10-03-2014	48.4	22.24	21.0
Note: All SAR values are normalized to 1W forward power.				

System Performance Check at 5200MHz				
Validation Dipole: D5GHzV2, SN: 1078				
Frequency [MHz]	Description	SAR [w/kg] 1g	SAR [w/kg] 10g	Tissue Temp. [°C]
5200 MHz	Reference result ± 10% window	73.1 65.79 to 80.41	20.5 18.45 to 22.55	N/A
	10-03-2014	76.7	21.6	21.0
Note: All SAR values are normalized to 1W forward power.				

System Performance Check at 5800MHz				
Validation Kit: D5GHzV2, SN: 1078				
Frequency [MHz]	Description	SAR [w/kg] 1g	SAR [w/kg] 10g	Tissue Temp. [°C]
5800 MHz	Reference result ± 10% window	73.5 66.15 to 80.85	20.3 18.27 to 22.33	N/A
	10-03-2014	75.1	20.7	21.0
Note: All SAR values are normalized to 1W forward power.				

4.2. SAR Measurement Procedure

The DASYS 5 calculates SAR using the following equation,

$$SAR = \frac{\sigma |E|^2}{\rho}$$

σ : represents the simulated tissue conductivity

ρ : represents the tissue density

The EUT is set to transmit at the required power in line with product specification, at each frequency relating to the LOW, MID, and HIGH channel settings.

Pre-scans are made on the device to establish the location for the transmitting antenna, using a large area scan in either air or tissue simulation fluid.

The EUT is placed against the Universal Phantom where the maximum area scan dimensions are larger than the physical size of the resonating antenna. When the scan size is not large enough to cover the peak SAR distribution, it is modified by either extending the area scan size in both the X and Y directions, or the device is shifted within the predefined area.

The area scan is then run to establish the peak SAR location (interpolated resolution set at 1mm²) which is then used to orient the center of the zoom scan. The zoom scan is then executed and the 1g and 10g averages are derived from the zoom scan volume (interpolated resolution set at 1mm³).

5. SAR Exposure Limits

SAR assessments have been made in line with the requirements of IEEE-1528, FCC Supplement C, and comply with ANSI/IEEE C95.1-1992 “Uncontrolled Environments” limits. These limits apply to a location which is deemed as “Uncontrolled Environment” which can be described as a situation where the general public may be exposed to an RF source with no prior knowledge or control over their exposure.

Limits for General Population/Uncontrolled Exposure (W/kg)

Type Exposure	Uncontrolled Environment Limit
Spatial Peak SAR (1g cube tissue for brain or body)	1.60 W/kg
Spatial Average SAR (whole body)	0.08 W/kg
Spatial Peak SAR (10g for hands, feet, ankles and wrist)	4.00 W/kg

6. Test Equipment List

Instrument	Manufacturer	Model No.	Serial No.	Cali. Due Date
Stäubli Robot TX60L	Stäubli	TX60L	F10/5C90A1/A/01	N/A
Controller	Stäubli	SP1	S-0034	N/A
Dipole Validation Kits	Speag	D2450V2	735	2015.06.11
Dipole Validation Kits	Speag	D5GHzV2	1040	2015.07.02
SAM Twin Phantom	Speag	SAM	TP-1561/1562	N/A
Device Holder	Speag	SD 000 H01 HA	N/A	N/A
Data Acquisition Electronic	Speag	DAE4	1220	2015.01.22
E-Field Probe	Speag	EX3DV4	3962	2014.12.10
SAR Software	Speag	DASY5	V5.2 Build 162	N/A
Power Amplifier	Mini-Circuit	ZHL-42	D051404-28	N/A
Directional Coupler	Agilent	778D	20160	N/A
Universal Radio Communication Tester	R&S	CMU 200	117088	2014.03.30
Vector Network	Agilent	E5071C	MY48367267	2014.03.30
Signal Generator	Agilent	E4438C	MY49070163	2014.03.30
Power Meter	Anritsu	ML2495A	0905006	2014.11.01
Wide Bandwidth Sensor	Anritsu	MA2411B	0846014	2014.11.01

Impedance Plot for D2450V2

2450 Head

Calibrated impedance: 55.7 Ω ; Measured impedance: 52.6 Ω (within 5 Ω)

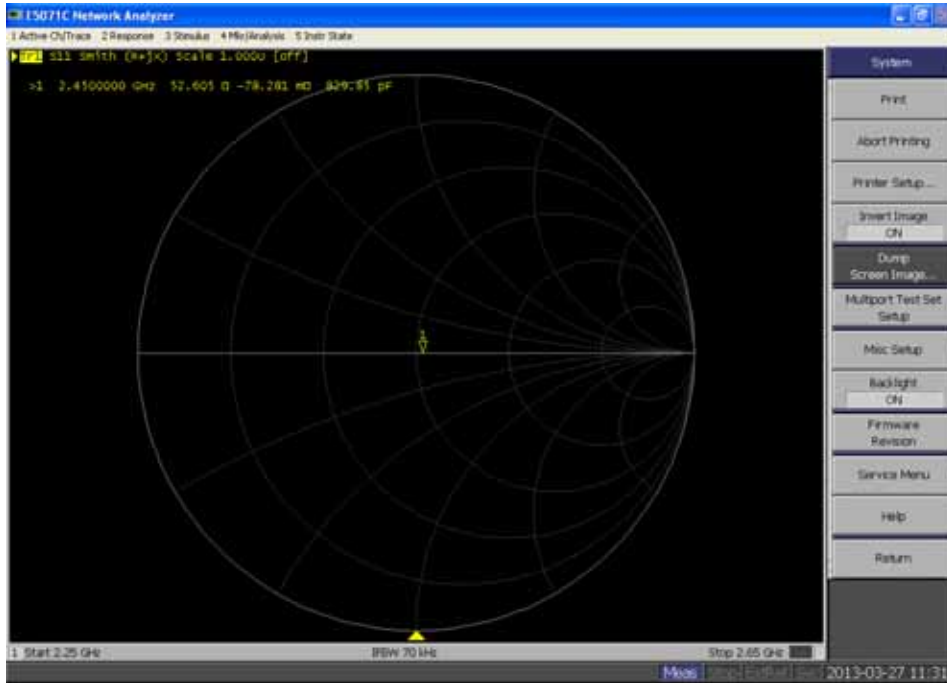

Calibrated return loss: -25.2 dB; Measured return loss: -23.9 dB (within 20%)

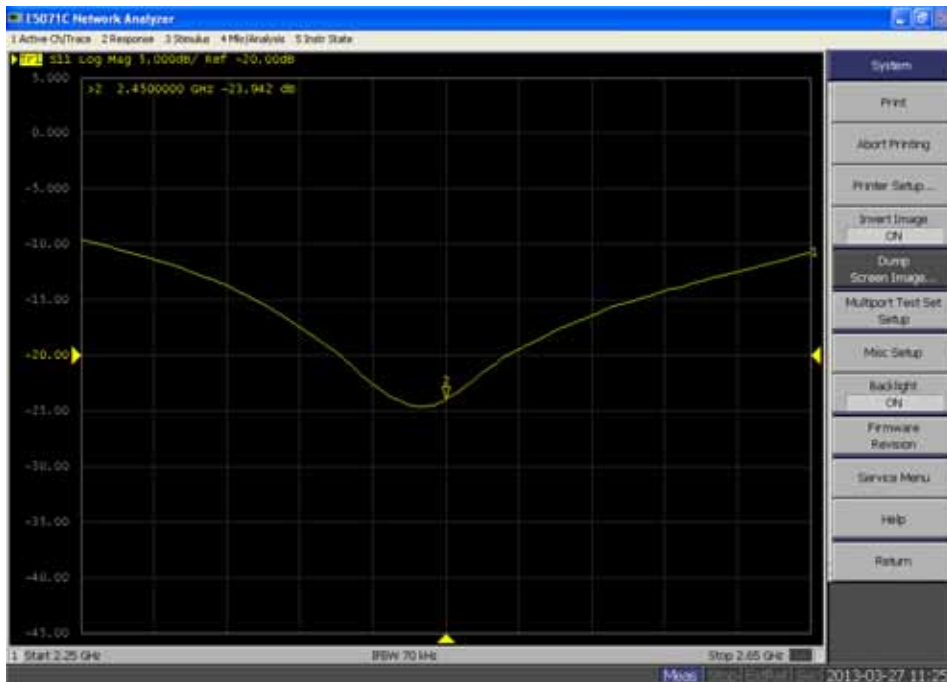

5200 Body

Calibrated impedance: 51.5 Ω; Measured impedance: 50.1 Ω (within 5Ω)

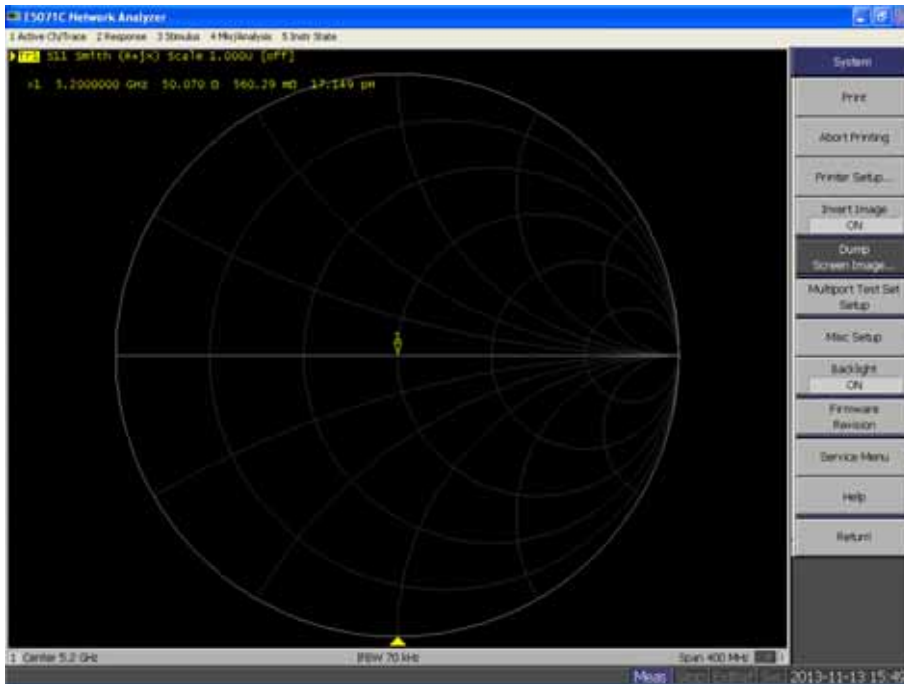

Calibrated return loss: -22 dB; Measured return loss: -20.7dB (within 20%)

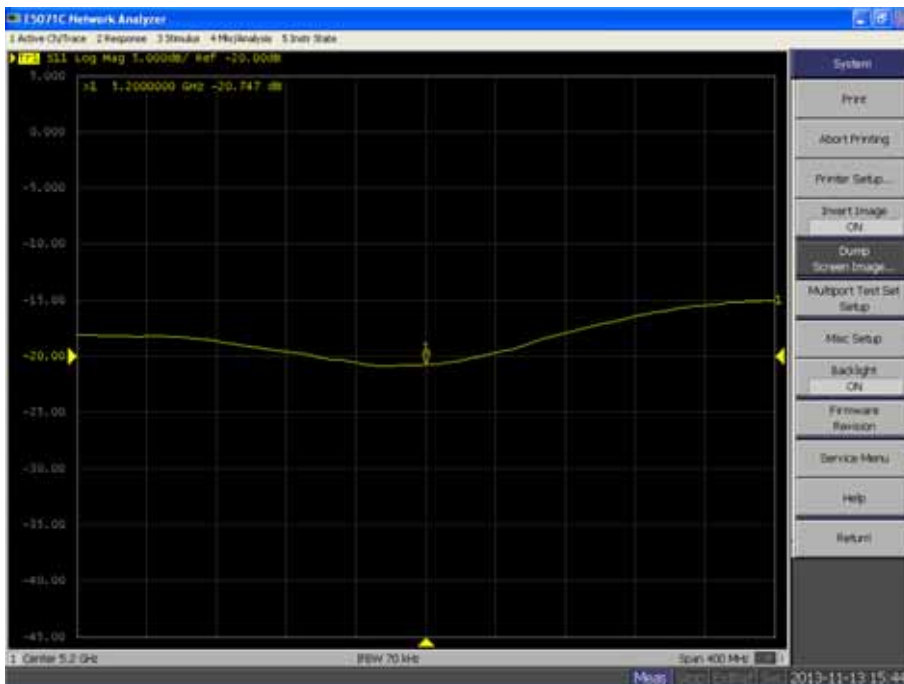

5800 Head

Calibrated impedance: 57.7 Ω ; Measured impedance: 55.365 Ω (within 5 Ω)

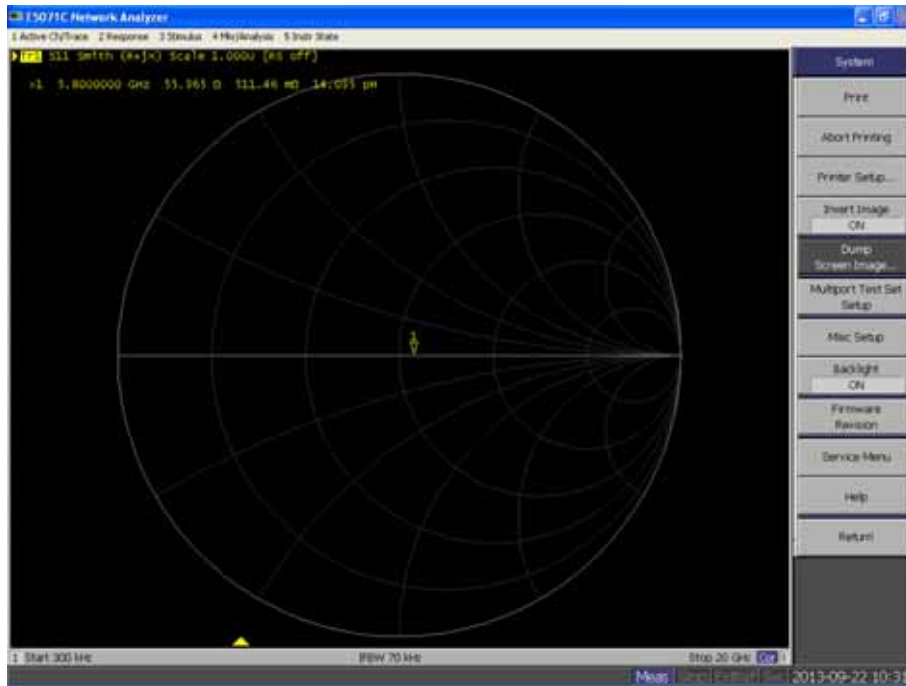

Calibrated return loss: -22.9 dB; Measured return loss: -22.217 dB (within 20%)

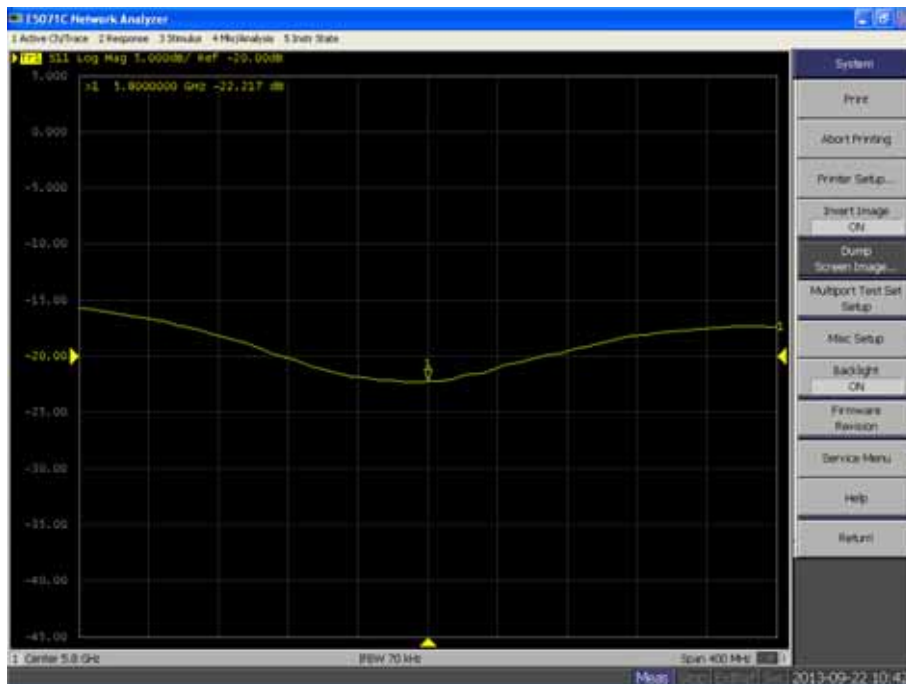

7. Measurement Uncertainty

DASY5 Uncertainty								
Measurement uncertainty for 300 MHz to 3 GHz averaged over 1 gram / 10 gram.								
Error Description	Uncert. value	Prob. Dist.	Div.	(ci) 1g	(ci) 10g	Std. Unc. (1g)	Std. Unc. (10g)	(vi) V _{eff}
Measurement System								
Probe Calibration	±6.0%	N	1	1	1	±6.0%	±6.0%	∞
Axial Isotropy	±4.7%	R	√3	0.7	0.7	±1.9%	±1.9%	∞
Hemispherical Isotropy	±9.6%	R	√3	0.7	0.7	±3.9%	±3.9%	∞
Boundary Effects	±1.0%	R	√3	1	1	±0.6%	±0.6%	∞
Linearity	±4.7%	R	√3	1	1	±2.7%	±2.7%	∞
System Detection Limits	±1.0%	R	√3	1	1	±0.6%	±0.6%	∞
Readout Electronics	±0.3%	N	1	1	1	±0.3%	±0.3%	∞
Response Time	±0.8%	R	√3	1	1	±0.5%	±0.5%	∞
Integration Time	±2.6%	R	√3	1	1	±1.5%	±1.5%	∞
RF Ambient Noise	±3.0%	R	√3	1	1	±1.7%	±1.7%	∞
RF Ambient Reflections	±3.0%	R	√3	1	1	±1.7%	±1.7%	∞
Probe Positioner	±0.4%	R	√3	1	1	±0.2%	±0.2%	∞
Probe Positioning	±2.9%	R	√3	1	1	±1.7%	±1.7%	∞
Max. SAR Eval.	±1.0%	R	√3	1	1	±0.6%	±0.6%	∞
Test Sample Related								
Device Positioning	±2.9%	N	1	1	1	±2.9%	±2.9%	145
Device Holder	±3.6%	N	1	1	1	±3.6%	±3.6%	5
Power Drift	±5.0%	R	√3	1	1	±2.9%	±2.9%	∞
Phantom and Setup								
Phantom Uncertainty	±4.0%	R	√3	1	1	±2.3%	±2.3%	∞
Liquid Conductivity (target)	±5.0%	R	√3	0.64	0.43	±1.8%	±1.2%	∞
Liquid Conductivity (meas.)	±2.5%	N	1	0.64	0.43	±1.6%	±1.1%	∞
Liquid Permittivity (target)	±5.0%	R	√3	0.6	0.49	±1.7%	±1.4%	∞
Liquid Permittivity (meas.)	±2.5%	N	1	0.6	0.49	±1.5%	±1.2%	∞
Combined Std. Uncertainty						±11.0%	±10.8%	387
Expanded STD Uncertainty						±22.0%	±21.5%	

DASY5 Uncertainty								
Measurement uncertainty for 3 GHz to 6 GHz averaged over 1 gram / 10 gram.								
Error Description	Uncert. value	Prob. Dist.	Div.	(ci) 1g	(ci) 10g	Std. Unc. (1g)	Std. Unc. (10g)	(vi) V _{eff}
Measurement System								
Probe Calibration	±6.55%	N	1	1	1	±6.55%	±6.55%	∞
Axial Isotropy	±4.7%	R	√3	0.7	0.7	±1.9%	±1.9%	∞
Hemispherical Isotropy	±9.6%	R	√3	0.7	0.7	±3.9%	±3.9%	∞
Boundary Effects	±2.0%	R	√3	1	1	±1.2%	±1.2%	∞
Linearity	±4.7%	R	√3	1	1	±2.7%	±2.7%	∞
System Detection Limits	±1.0%	R	√3	1	1	±0.6%	±0.6%	∞
Readout Electronics	±0.3%	N	1	1	1	±0.3%	±0.3%	∞
Response Time	±0.8%	R	√3	1	1	±0.5%	±0.5%	∞
Integration Time	±2.6%	R	√3	1	1	±1.5%	±1.5%	∞
RF Ambient Noise	±3.0%	R	√3	1	1	±1.7%	±1.7%	∞
RF Ambient Reflections	±3.0%	R	√3	1	1	±1.7%	±1.7%	∞
Probe Positioner	±0.8%	R	√3	1	1	±0.5%	±0.5%	∞
Probe Positioning	±9.9%	R	√3	1	1	±5.7%	±5.7%	∞
Max. SAR Eval.	±4.0%	R	√3	1	1	±2.3%	±2.3%	∞
Test Sample Related								
Device Positioning	±2.9%	N	1	1	1	±2.9%	±2.9%	145
Device Holder	±3.6%	N	1	1	1	±3.6%	±3.6%	5
Power Drift	±5.0%	R	√3	1	1	±2.9%	±2.9%	∞
Phantom and Setup								
Phantom Uncertainty	±4.0%	R	√3	1	1	±2.3%	±2.3%	∞
Liquid Conductivity (target)	±5.0%	R	√3	0.64	0.43	±1.8%	±1.2%	∞
Liquid Conductivity (meas.)	±2.5%	N	1	0.64	0.43	±1.6%	±1.1%	∞
Liquid Permittivity (target)	±5.0%	R	√3	0.6	0.49	±1.7%	±1.4%	∞
Liquid Permittivity (meas.)	±2.5%	N	1	0.6	0.49	±1.5%	±1.2%	∞
Combined Std. Uncertainty						±12.8%	±12.6%	330
Expanded STD Uncertainty						±25.6%	±25.2%	

8. Conducted Power Measurement

1Tx Chain 0

Test Mode	Frequency (MHz)	Avg. Burst Power (dBm)	Max. Power (dBm)	Scaling Factor
802.11b	2412	23.41	23.5	1.021
	2437	20.14	20.5	1.086
	2457	23.23	23.5	1.064
	2462	19.58	20.5	1.236
802.11g	2412	23.82	24.5	1.169
	2437	24.25	24.5	1.059
	2462	23.57	24.5	1.239
802.11n(20MHz)	2412	23.91	24.0	1.021
	2437	23.93	24.0	1.016
	2462	22.47	24.0	1.422
802.11n(40MHz)	2422	22.67	24.0	1.358
	2437	23.83	24.0	1.040
	2452	22.63	24.0	1.371
802.11a	5180	15.83	17.0	1.309
	5200	16.52	17.0	1.117
	5220	16.28	17.0	1.180
	5240	16.31	17.0	1.172
	5745	22.51	23.5	1.256
	5765	22.43	23.5	1.279
	5785	23.01	23.5	1.119
	5805	22.19	23.5	1.352
	5825	22.26	23.5	1.330
802.11n(20MHz)	5180	11.72	12.7	1.253
	5200	12.63	12.7	1.016
	5220	11.75	12.7	1.245
	5240	11.79	12.7	1.233
	5745	22.46	23.2	1.186
	5765	22.43	23.2	1.194
	5785	23.16	23.2	1.009
	5805	22.22	23.2	1.253
	5825	22.24	23.2	1.247
802.11n(40MHz)	5190	11.19	11.5	1.074
	5230	11.23	11.5	1.064
	5755	22.13	22.2	1.016
	5795	21.89	22.2	1.074

1Tx Chain 1

Test Mode	Frequency (MHz)	Avg. Burst Power (dBm)	Max. Power (dBm)	Scaling Factor
802.11b	2412	22.16	22.2	1.009
	2437	20.11	20.2	1.021
	2457	22.05	22.2	1.035
	2462	18.98	20.2	1.324
802.11g	2412	22.89	23.0	1.026
	2437	22.65	23.0	1.084
	2462	22.37	23.0	1.156
802.11n(20MHz)	2412	22.58	22.6	1.005
	2437	22.38	22.6	1.052
	2462	21.41	22.6	1.315
802.11n(40MHz)	2422	22.16	23.3	1.300
	2437	23.21	23.3	1.021
	2452	22.81	23.3	1.119
802.11a	5180	15.67	16.8	1.297
	5200	16.70	16.8	1.023
	5220	16.35	16.8	1.109
	5240	16.41	16.8	1.094
	5745	21.98	22.9	1.236
	5765	21.92	22.9	1.253
	5785	22.85	22.9	1.012
	5805	22.19	22.9	1.178
	5825	22.31	22.9	1.146
802.11n(20MHz)	5180	11.87	13.0	1.297
	5200	12.96	13.0	1.009
	5220	11.57	13.0	1.390
	5240	11.61	13.0	1.377
	5745	22.73	23.7	1.250
	5765	22.64	23.7	1.276
	5785	23.69	23.7	1.002
	5805	22.51	23.7	1.315
	5825	22.56	23.7	1.300
802.11n(40MHz)	5190	11.27	11.7	1.104
	5230	11.64	11.7	1.014
	5755	21.48	21.5	1.005
	5795	21.33	21.5	1.040

2Tx Chain 0+1

Test Mode	Frequency (MHz)	Avg. Burst Power (dBm)	Max. Power (dBm)	Scaling Factor
802.11n(20MHz)	2412	27.00	27.2	1.047
	2437	26.43	27.2	1.194
	2462	26.78	27.2	1.102
	5180	13.80	15.0	1.318
	5200	14.81	15.0	1.045
	5220	13.74	15.0	1.337
	5240	13.82	15.0	1.312
	5745	25.25	26.1	1.216
	5765	25.22	26.1	1.225
	5785	26.01	26.1	1.021
	5805	25.18	26.1	1.236
	5825	25.21	26.1	1.227
802.11n(40MHz)	2422	24.90	25.7	1.202
	2437	25.61	25.7	1.021
	2452	24.06	25.7	1.459
	5190	13.73	14.0	1.064
	5230	13.71	14.0	1.069
	5755	25.02	25.5	1.117
	5795	25.46	25.5	1.009

Note : According to KDB 248227:

- 1, SAR is not required for 802.11g/n channels when the maximum average output power is less than 1/4 dB higher than that measured on the corresponding 802.11b channels.
- 2, When the maximum average output channel in each frequency band is not included in the "default test channels", the maximum channel should be tested instead of an adjacent "default test channel".

9. Test Procedures

9.1. SAR Test Results Summary

SAR MEASUREMENT									
Ambient Temperature (°C) : 21.5 ± 2					Relative Humidity (%): 52				
Liquid Temperature (°C) : 21.0 ± 2					Depth of Liquid (cm):>15				
Product: IP-STB									
Test Mode: 802.11b- 1Tx Chain 0									
Test Position Head	Antenna Position	Frequency		Frame Power (dBm)	Power Drift (<±0.2)	SAR 1g (W/kg)	Scaling Factor	Scaled SAR 1g (W/kg)	Limit (W/kg)
		Channel	MHz						
Horizontal Up	Fixed	01	2412	23.41	0.02	0.276	1.021	0.282	1.6
Horizontal Down	Fixed	01	2412	23.41	0.08	0.209	1.021	0.213	1.6
Vertical Front	Fixed	01	2412	23.41	0.06	0.049	1.021	0.050	1.6
Vertical Back	Fixed	01	2412	23.41	0.11	0.291	1.021	0.297	1.6
Vertical Back	Fixed	06	2437	20.14	0.15	0.174	1.086	0.189	1.6
Vertical Back	Fixed	10	2457	23.23	0.15	0.301	1.064	0.320	1.6
Tip	Fixed	01	2412	23.41	0.04	0.203	1.021	0.207	1.6
Test Mode: 802.11b- 1Tx Chain 1									
Vertical Back	Fixed	01	2412	22.16	0.01	0.203	1.009	0.205	1.6
Test Mode: 802.11g- 1Tx Chain 0									
Vertical Back	Fixed	01	2412	23.82	0.12	0.150	1.169	0.175	1.6
Vertical Back	Fixed	06	2437	24.25	0.07	0.173	1.059	0.183	1.6
Vertical Back	Fixed	11	2462	23.57	-0.06	0.170	1.239	0.211	1.6
Test Mode: 802.11n(20MHz)- 2Tx Chain 0+1									

Vertical Back	Fixed	01	2412	27.00	0.04	0.079	1.047	0.083	1.6
Vertical Back	Fixed	06	2437	26.43	-0.07	0.347	1.194	0.414	1.6
Vertical Back	Fixed	11	2462	26.78	0.17	0.143	1.102	0.158	1.6
Test Mode: 802.11n(40MHz)- 2Tx Chain 0+1									
Vertical Back	Fixed	03	2422	24.90	0.14	0.052	1.202	0.063	1.6
Vertical Back	Fixed	06	2437	25.61	0.18	0.207	1.021	0.211	1.6
Vertical Back	Fixed	09	2452	24.06	0.01	0.086	1.459	0.125	1.6
Note: when the 1-g SAR is ≤ 0.8 W/kg, testing for low and high channel is optional, refer to KDB 447498.									

SAR MEASUREMENT									
Ambient Temperature (°C) : 21.5 ± 2					Relative Humidity (%): 52				
Liquid Temperature (°C) : 21.0 ± 2					Depth of Liquid (cm):>15				
Product: IP-STB									
Test Mode: 802.11a-5.2G 1Tx Chain 1									
Test Position Body (10mm gap)	Antenna Position	Frequency		Frame Power (dBm)	Power Drift (<±0.2)	SAR 1g (W/kg)	Scaling Factor	Scaled SAR 1g (W/kg)	Limit (W/kg)
		Channel	MHz						
Horizontal Up	Fixed	40	5200	16.70	0.03	0.657	1.023	0.672	1.6
Horizontal Down	Fixed	40	5200	16.70	0.08	0.710	1.023	0.726	1.6
Vertical Front	Fixed	40	5200	16.70	0.02	0.975	1.023	0.997	1.6
Vertical Back	Fixed	40	5200	16.70	0.11	0.097	1.023	0.099	1.6
Tip	Fixed	40	5200	16.70	0.06	0.285	1.023	0.292	1.6
Vertical Front	Fixed	48	5240	16.41	0.03	1.17	1.094	1.28	1.6
Vertical Front*	Fixed	48	5240	16.41	0.08	1.16	1.094	1.27	1.6
Test Mode: 802.11a- 1Tx Chain 0									
Vertical Front	Fixed	40	5200	16.52	0.09	0.205	1.117	0.229	1.6
Test Mode: 802.11n(20MHz)- 2Tx Chain 0+1									
Vertical Front	Fixed	40	5200	14.81	0.17	0.487	1.045	0.509	1.6
Vertical Front	Fixed	48	5240	13.82	0.10	0.406	1.312	0.533	1.6
Test Mode: 802.11n(40MHz)- 2Tx Chain 0+1									
Vertical Front	Fixed	38	5190	13.73	0.14	0.364	1.064	0.387	1.6
Note 1: when the 1-g SAR is ≤ 0.8 W/kg, testing for low and high channel is optional, refer to KDB 447498.									
2: * - repeated at the highest SAR measurement according to the FCC KDB 865664									

SAR MEASUREMENT									
Ambient Temperature (°C) : 21.5 ± 2					Relative Humidity (%): 52				
Liquid Temperature (°C) : 21.0 ± 2					Depth of Liquid (cm):>15				
Product: IP-STB									
Test Mode: 802.11a-5.8G 1Tx Chain 1									
Test Position Head	Antenna Position	Frequency		Frame Power (dBm)	Power Drift (<±0.2)	SAR 1g (W/kg)	Scaling Factor	Scaled SAR 1g (W/kg)	Limit (W/kg)
		Channel	MHz						
Horizontal Up	Fixed	157	5785	22.85	0.06	0.666	1.012	0.674	1.6
Horizontal Down	Fixed	157	5785	22.85	0.13	0.614	1.012	0.621	1.6
Vertical Front	Fixed	157	5785	22.85	0.05	0.874	1.012	0.884	1.6
Vertical Front*	Fixed	157	5785	22.85	0.04	1.2	1.012	1.21	1.6
Vertical Back	Fixed	157	5785	22.85	-0.12	0.118	1.012	0.119	1.6
Tip	Fixed	157	5785	22.85	-0.14	0.447	1.012	0.452	1.6
Vertical Front	Fixed	149	5745	21.98	0.20	0.674	1.236	0.833	1.6
Vertical Front	Fixed	165	5825	22.31	0.09	0.849	1.146	0.973	1.6
Test Mode: 802.11a- 1Tx Chain 0									
Vertical Front	Fixed	157	5785	23.01	0.12	0.776	1.119	0.868	1.6
Test Mode: 802.11n(20MHz)- 2Tx Chain 0+1									
Vertical Front	Fixed	149	5745	25.25	0.18	0.308	1.216	0.375	1.6
Vertical Front	Fixed	157	5785	26.01	0.05	0.409	1.021	0.418	1.6
Vertical Front	Fixed	165	5825	25.21	0.16	0.273	1.227	0.335	1.6
Test Mode: 802.11n(40MHz)- 2Tx Chain 0+1									
Vertical Front	Fixed	159	5795	25.46	0.15	0.49	1.009	0.494	1.6
Note: when the 1-g SAR is ≤ 0.8 W/kg, testing for low and high channel is optional, refer to KDB 447498.									

9.2. Test position and configuration

1. Batteries are fully charged at the beginning of the SAR measurements.
2. Liquid tissue depth was at least 15.0 cm for all frequencies.
3. The manufacturer has confirmed that the device(s) tested have the same physical, mechanical and thermal characteristics and are within operational tolerances expected for production units.
4. SAR results were scaled to the maximum allowed power to demonstrate compliance per FCC KDB Publication 447498 D01v05r02.
5. SAR was performed with the device configured in the positions according to KDB 447498 D02 SAR Procedures for Dongle Xmtr v02, body SAR was performed with the device to phantom separation distance of 5mm. All USB orientations (A: Horizontal-Up, B: Horizontal-Down, C: Vertical-Front, D: Vertical-Back, and E: Tip) were evaluated with 15cm USB cable for extension. Please check the SAR test photos.

WLAN Notes:

1. Justification for reduced test configurations for Wi-Fi channels per KDB Publication 248227 D01v01r02 and April 2010 FCC/TCB Meeting Notes for 2.4 GHz Wi-Fi: Highest average RF output power channel for the lowest data rate was selected for SAR evaluation in 802.11b. Other IEEE 802.11 modes (including 802.11g/n) were not investigated since the average output powers over all channels and data rates were not more than 0.25 dB higher than the tested channel in the lowest data rate of IEEE 802.11b mode.
2. When the maximum extrapolated peak SAR of the zoom scan for the maximum output channel is <1.6 W/kg and the reported 1g averaged SAR is <0.8 W/kg, SAR testing on other default channels is not required.

Appendix A. SAR System Validation Data

Date/Time: 10-03-2014

Test Laboratory: QuieTek Lab

System Check Body 2450MHz

DUT: Dipole 2450 MHz D2450V2; Type: D2450V2

Communication System: CW; Communication System Band: Exported from older format (data unavailable - please correct).; Duty Cycle: 1:1; Frequency: 2450 MHz; Medium parameters used: $f = 2450$ MHz; $\sigma = 1.97$ mho/m; $\epsilon_r = 52.67$; $\rho = 1000$ kg/m³; Phantom section: Flat Section; Input Power=250mW

Ambient temperature (): 21.5, Liquid temperature (): 21.0

DASY5 Configuration:

- Probe: EX3DV4 - SN3962; ConvF(7.13, 7.13, 7.13); Calibrated: 10/12/2013;
- Sensor-Surface: 4mm (Mechanical Surface Detection)
- Electronics: DAE4 Sn1220; Calibrated: 22/01/2014
- Phantom: SAM1; Type: SAM; Serial: TP1561
- Measurement SW: DASY52, Version 52.8 (1); SEMCAD X Version 14.6.5 (6469)

Configuration/System Check Body 2450MHz/Area Scan (7x11x1): Measurement grid: dx=10mm, dy=10mm

Maximum value of SAR (measured) = 13.3 mW/g

Configuration/System Check Body 2450MHz/Zoom Scan (7x7x7)/Cube 0: Measurement grid: dx=5mm, dy=5mm, dz=5mm, Reference Value = 81.579 V/m; Power Drift = 0.17 dB

Peak SAR (extrapolated) = 25.093 mW/g

SAR(1 g) = 12.1 mW/g; SAR(10 g) = 5.56 mW/g Maximum value of SAR (measured) = 13.9 mW/g

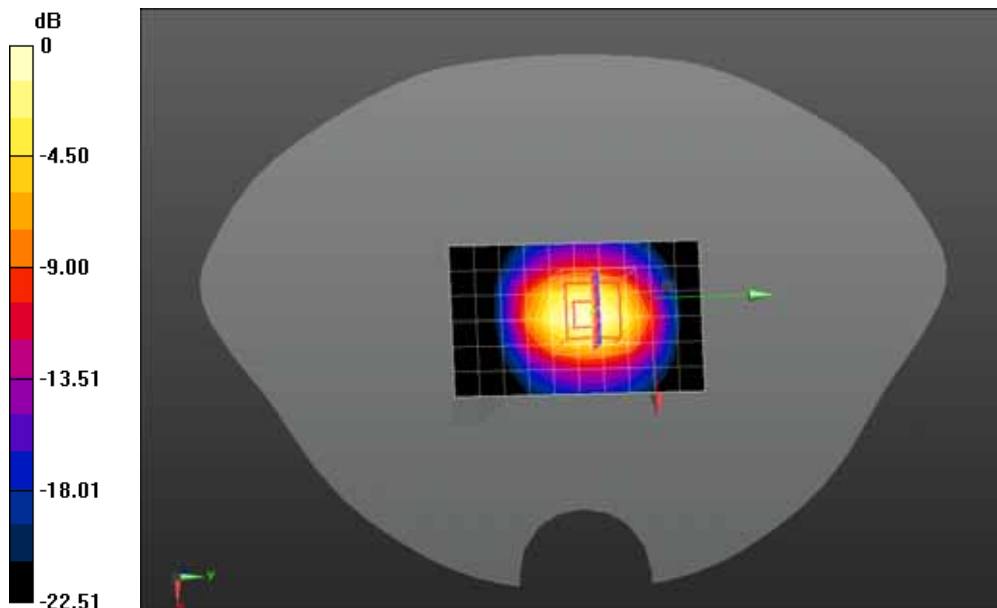

0 dB = 13.9 mW/g = 22.86 dB mW/g

Date/Time: 10-03-2014

Test Laboratory: QuieTek Lab

System Check Body 5200MHz

DUT: Dipole D5GHzV2; Type: D5GHzV2

Communication System: CW; Communication System Band: 5GHz; Duty Cycle: 1:1; Frequency: 5200 MHz;
 Medium parameters used: $f = 5200 \text{ MHz}$; $\sigma = 5.15 \text{ mho/m}$; $\epsilon_r = 48.94$; $\rho = 1000 \text{ kg/m}^3$; Phantom section:
 Flat Section; Input Power=100mW

Ambient temperature (): 21.5, Liquid temperature (): 21.0

DASY5 Configuration:

- Probe: EX3DV4 - SN3962; ConvF(4.18, 4.18, 4.18); Calibrated: 10/12/2013;
- Sensor-Surface: 2mm (Mechanical Surface Detection)
- Electronics: DAE4 Sn1220; Calibrated: 22/01/2014
- Phantom: SAM2; Type: SAM; Serial: TP1562
- Measurement SW: DASY52, Version 52.8 (1); SEMCAD X Version 14.6.5 (6469)

Configuration/System Check Body 5200MHz/Area Scan (5x8x1): Measurement grid: dx=10mm, dy=10mm

Maximum value of SAR (measured) = 14.0 mW/g

Configuration/System Check Body 5200MHz/Zoom Scan (8x8x10)/Cube 0: Measurement grid: dx=4mm, dy=4mm, dz=2.5mm, Reference Value = 41.965 V/m; Power Drift = 0.08 dB

Peak SAR (extrapolated) = 28.902 mW/g

SAR(1 g) = 7.67 mW/g; SAR(10 g) = 2.16 mW/g Maximum value of SAR (measured) = 15.2 mW/g

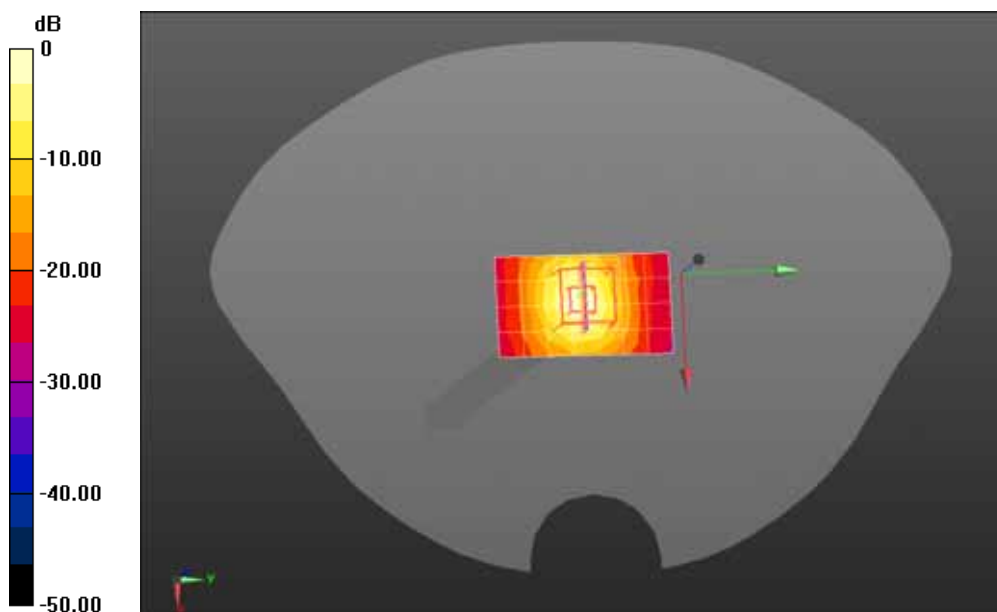

0 dB = 15.2 mW/g = 23.64 dB mW/g

Date/Time: 10-03-2014

Test Laboratory: QuieTek Lab

System Check Body 5800MHz

DUT: Dipole D5GHzV2; Type: D5GHzV2

Communication System: CW; Communication System Band: 5GHz; Duty Cycle: 1:1; Frequency: 5800 MHz;
 Medium parameters used: $f = 5800 \text{ MHz}$; $\sigma = 6.04 \text{ mho/m}$; $\epsilon_r = 47.29$; $\rho = 1000 \text{ kg/m}^3$; Phantom section:
 Flat Section ; Input Power=100mW

Ambient temperature (): 21.5, Liquid temperature (): 21.0

DASY5 Configuration:

- Probe: EX3DV4 - SN3962; ConvF(3.96, 3.96, 3.96); Calibrated: 10/12/2013;
- Sensor-Surface: 2mm (Mechanical Surface Detection)
- Electronics: DAE4 Sn1220; Calibrated: 22/01/2014
- Phantom: SAM2; Type: SAM; Serial: TP1562
- Measurement SW: DASY52, Version 52.8 (1); SEMCAD X Version 14.6.5 (6469)

Configuration/System Check Body 5800MHz/Area Scan (5x8x1): Measurement grid: dx=10mm, dy=10mm

Maximum value of SAR (measured) = 13.2 mW/g

Configuration/System Check Body 5800MHz/Zoom Scan (8x8x10)/Cube 0: Measurement grid: dx=4mm, dy=4mm, dz=2.5mm, Reference Value = 38.530 V/m; Power Drift = 0.04 dB

Peak SAR (extrapolated) = 31.046 mW/g

SAR(1 g) = 7.51 mW/g; SAR(10 g) = 2.07 mW/g Maximum value of SAR (measured) = 15.1 mW/g

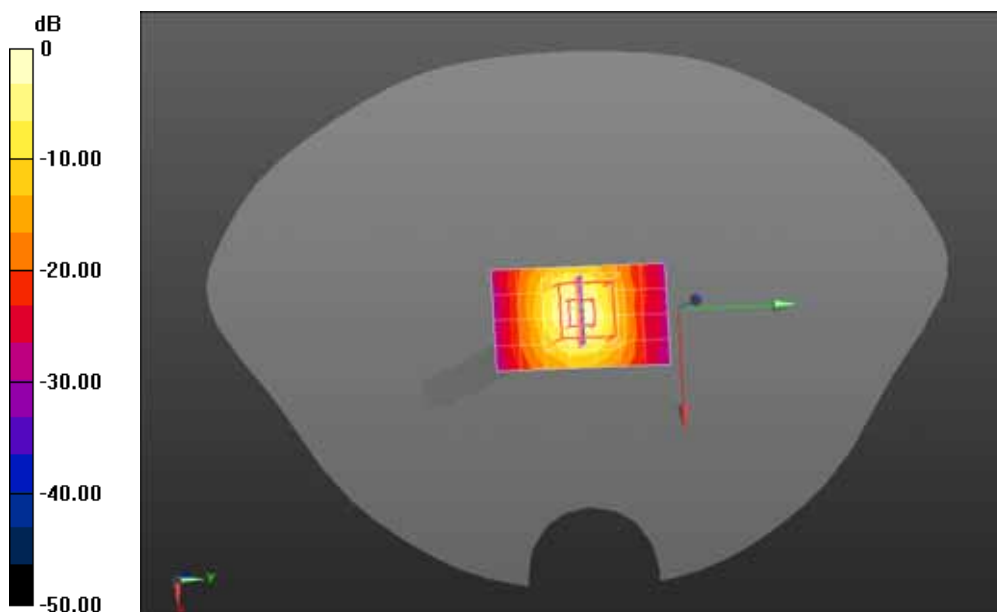

0 dB = 15.1 mW/g = 23.58 dB mW/g

Appendix B. SAR measurement Data

Date/Time: 10-03-2014

Test Laboratory: QuieTek Lab

802.11b 2412MHz Horizontal up-ant 0

DUT: IP-STB; Type: 3500X

Communication System: Wi-Fi; Communication System Band: 802.11b; Duty Cycle: 1:1.0; Frequency: 2412 MHz; Medium parameters used: $f = 2412$ MHz; $\sigma = 1.92$ mho/m; $\epsilon_r = 52.49$; $\rho = 1000$ kg/m³; Phantom section: Flat Section

Ambient temperature (): 21.5, Liquid temperature (): 21.0

DASY5 Configuration:

- Probe: EX3DV4 - SN3962; ConvF(7.13, 7.13, 7.13); Calibrated: 10/12/2013;
- Sensor-Surface: 4mm (Mechanical Surface Detection)
- Electronics: DAE4 Sn1220; Calibrated: 22/01/2014
- Phantom: SAM1; Type: SAM; Serial: TP1561
- Measurement SW: DASY52, Version 52.8 (1); SEMCAD X Version 14.6.5 (6469)

Configuration/802.11b 2412MHz Horizontal up/Area Scan (6x11x1): Measurement grid: dx=12mm, dy=12mm

Maximum value of SAR (measured) = 0.262 mW/g

Configuration/802.11b 2412MHz Horizontal up/Zoom Scan (5x5x7)/Cube 0: Measurement grid:

dx=8mm, dy=8mm, dz=5mm, Reference Value = 8.520 V/m; Power Drift = 0.02 dB

Peak SAR (extrapolated) = 0.677 mW/g

SAR(1 g) = 0.276 mW/g; SAR(10 g) = 0.111 mW/g Maximum value of SAR (measured) = 0.343 mW/g

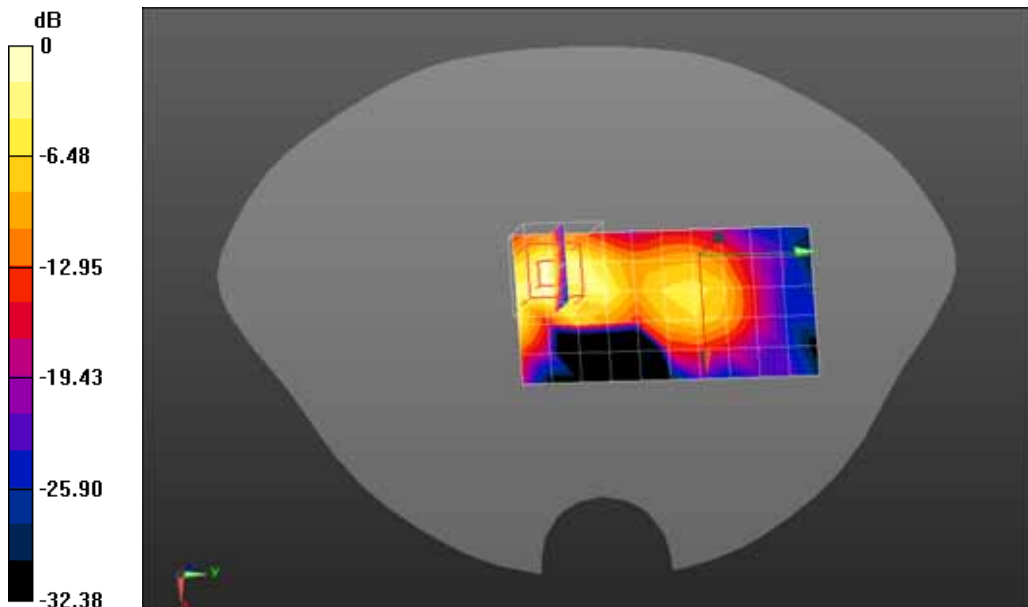

0 dB = 0.343 mW/g = -9.29 dB mW/g

Date/Time: 10-03-2014

Test Laboratory: QuieTek Lab

802.11b 2412MHz Horizontal down-ant 0

DUT: IP-STB; Type: 3500X

Communication System: Wi-Fi; Communication System Band: 802.11b; Duty Cycle: 1:1.0; Frequency: 2412 MHz; Medium parameters used: $f = 2412$ MHz; $\sigma = 1.92$ mho/m; $\epsilon_r = 52.49$; $\rho = 1000$ kg/m³; Phantom section: Flat Section

Ambient temperature (): 21.5, Liquid temperature (): 21.0

DASY5 Configuration:

- Probe: EX3DV4 - SN3962; ConvF(7.13, 7.13, 7.13); Calibrated: 10/12/2013;
- Sensor-Surface: 4mm (Mechanical Surface Detection)
- Electronics: DAE4 Sn1220; Calibrated: 22/01/2014
- Phantom: SAM1; Type: SAM; Serial: TP1561
- Measurement SW: DASY52, Version 52.8 (1); SEMCAD X Version 14.6.5 (6469)

Configuration/802.11b 2412MHz Horizontal down/Area Scan (6x11x1): Measurement grid: dx=12mm, dy=12mm

Maximum value of SAR (measured) = 0.232 mW/g

Configuration/802.11b 2412MHz Horizontal down/Zoom Scan (5x5x7)/Cube 0: Measurement grid: dx=8mm, dy=8mm, dz=5mm, Reference Value = 7.844 V/m; Power Drift = 0.08 dB

Peak SAR (extrapolated) = 0.462 mW/g

SAR(1 g) = 0.209 mW/g; SAR(10 g) = 0.093 mW/g Maximum value of SAR (measured) = 0.244 mW/g

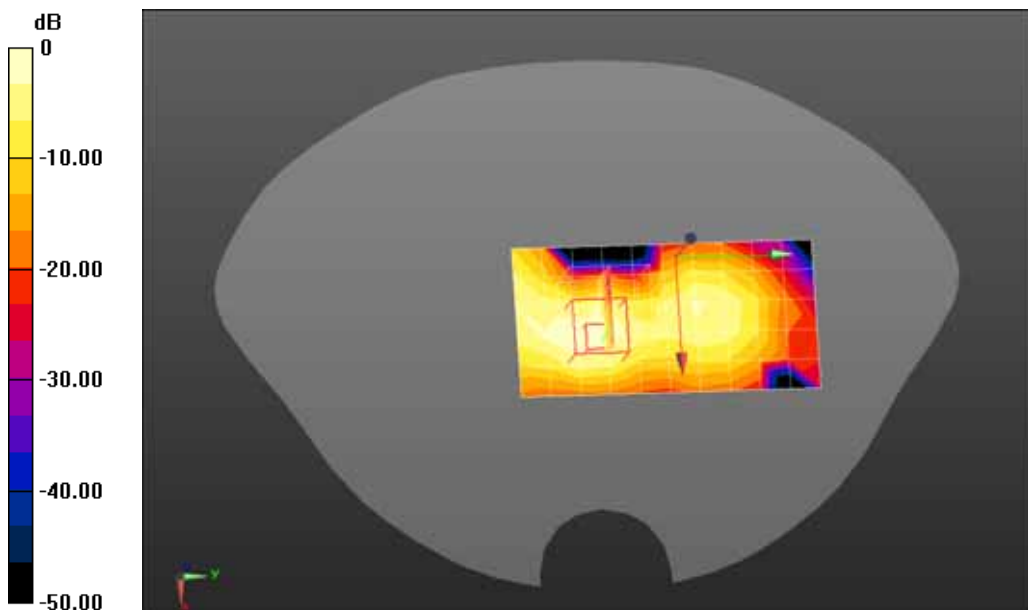

0 dB = 0.244 mW/g = -12.25 dB mW/g

Date/Time: 10-03-2014

Test Laboratory: QuieTek Lab

802.11b 2412MHz Vertical front-ant 0

DUT: IP-STB; Type: 3500X

Communication System: Wi-Fi; Communication System Band: 802.11b; Duty Cycle: 1:1.0; Frequency: 2412 MHz; Medium parameters used: $f = 2412$ MHz; $\sigma = 1.92$ mho/m; $\epsilon_r = 52.49$; $\rho = 1000$ kg/m³; Phantom section: Flat Section

Ambient temperature (): 21.5, Liquid temperature (): 21.0

DASY5 Configuration:

- Probe: EX3DV4 - SN3962; ConvF(7.13, 7.13, 7.13); Calibrated: 10/12/2013;
- Sensor-Surface: 4mm (Mechanical Surface Detection)
- Electronics: DAE4 Sn1220; Calibrated: 22/01/2014
- Phantom: SAM1; Type: SAM; Serial: TP1561
- Measurement SW: DASY52, Version 52.8 (1); SEMCAD X Version 14.6.5 (6469)

Configuration/802.11b 2412MHz Vertical front/Area Scan (6x11x1): Measurement grid: dx=12mm, dy=12mm

Maximum value of SAR (measured) = 0.0476 mW/g

Configuration/802.11b 2412MHz Vertical front/Zoom Scan (5x5x7)/Cube 0: Measurement grid: dx=8mm, dy=8mm, dz=5mm, Reference Value = 0.668 V/m; Power Drift = 0.06 dB

Peak SAR (extrapolated) = 0.097 mW/g

SAR(1 g) = 0.049 mW/g; SAR(10 g) = 0.023 mW/g Maximum value of SAR (measured) = 0.0538 mW/g

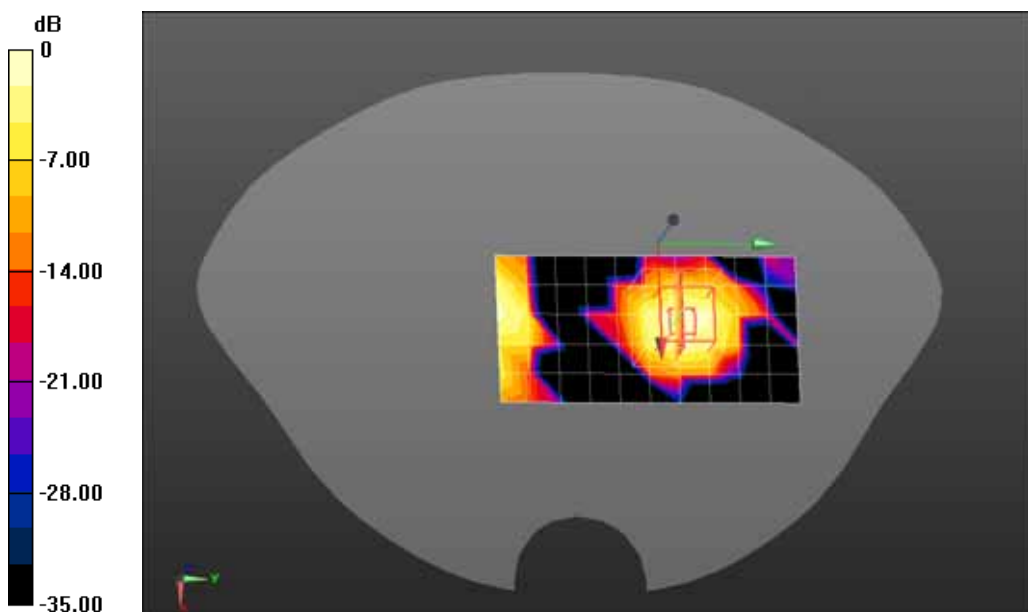

0 dB = 0.0538 mW/g = -25.38 dB mW/g

Date/Time: 10-03-2014

Test Laboratory: QuieTek Lab

802.11b 2412MHz Vertical back-ant 0

DUT: IP-STB; Type: 3500X

Communication System: Wi-Fi; Communication System Band: 802.11b; Duty Cycle: 1:1.0; Frequency: 2412 MHz; Medium parameters used: $f = 2412$ MHz; $\sigma = 1.92$ mho/m; $\epsilon_r = 52.49$; $\rho = 1000$ kg/m³; Phantom section: Flat Section

Ambient temperature (): 21.5, Liquid temperature (): 21.0

DASY5 Configuration:

- Probe: EX3DV4 - SN3962; ConvF(7.13, 7.13, 7.13); Calibrated: 10/12/2013;
- Sensor-Surface: 4mm (Mechanical Surface Detection)
- Electronics: DAE4 Sn1220; Calibrated: 22/01/2014
- Phantom: SAM1; Type: SAM; Serial: TP1561
- Measurement SW: DASY52, Version 52.8 (1); SEMCAD X Version 14.6.5 (6469)

Configuration/802.11b 2412MHz Vertical back/Area Scan (6x11x1): Measurement grid: dx=12mm, dy=12mm

Maximum value of SAR (measured) = 0.287 mW/g

Configuration/802.11b 2412MHz Vertical back/Zoom Scan (5x5x7)/Cube 0: Measurement grid: dx=8mm, dy=8mm, dz=5mm, Reference Value = 11.967 V/m; Power Drift = 0.11 dB

Peak SAR (extrapolated) = 0.828 mW/g

SAR(1 g) = 0.291 mW/g; SAR(10 g) = 0.107 mW/g Maximum value of SAR (measured) = 0.320 mW/g

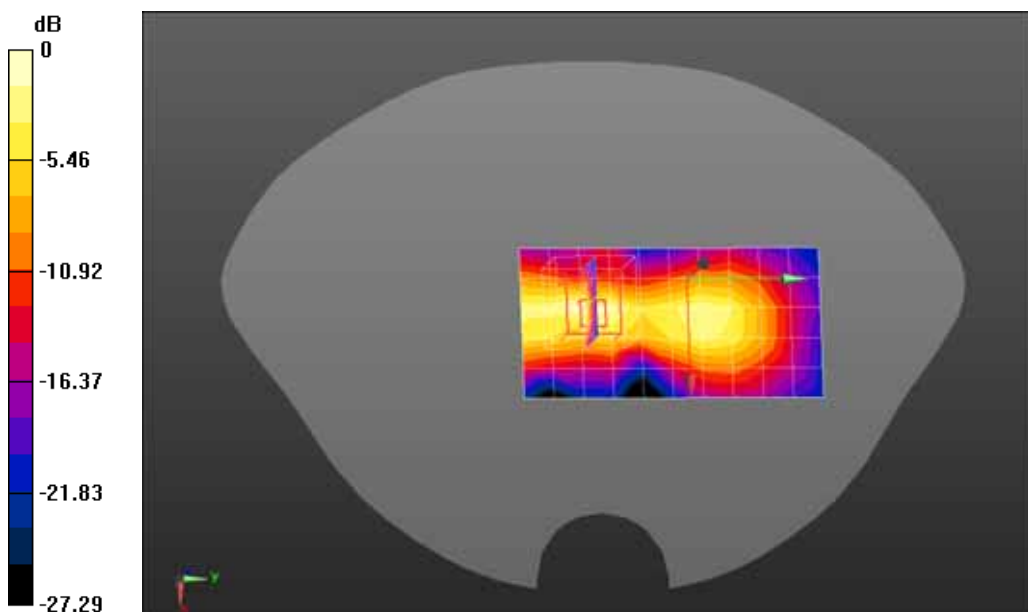

0 dB = 0.320 mW/g = -9.90 dB mW/g

Date/Time: 10-03-2014

Test Laboratory: QuieTek Lab

802.11b 2437MHz Vertical back-ant 0

DUT: IP-STB; Type: 3500X

Communication System: Wi-Fi; Communication System Band: 802.11b; Duty Cycle: 1:1.0; Frequency: 2412 MHz; Medium parameters used: $f = 2412$ MHz; $\sigma = 1.92$ mho/m; $\epsilon_r = 52.49$; $\rho = 1000$ kg/m³; Phantom section: Flat Section

Ambient temperature (): 21.5, Liquid temperature (): 21.0

DASY5 Configuration:

- Probe: EX3DV4 - SN3962; ConvF(7.13, 7.13, 7.13); Calibrated: 10/12/2013;
- Sensor-Surface: 4mm (Mechanical Surface Detection)
- Electronics: DAE4 Sn1220; Calibrated: 22/01/2014
- Phantom: SAM1; Type: SAM; Serial: TP1561
- Measurement SW: DASY52, Version 52.8 (1); SEMCAD X Version 14.6.5 (6469)

Configuration/802.11b 2437MHz Vertical back/Area Scan (6x11x1): Measurement grid: dx=12mm, dy=12mm

Maximum value of SAR (measured) = 0.176 mW/g

Configuration/802.11b 2437MHz Vertical back/Zoom Scan (5x5x7)/Cube 0: Measurement grid: dx=8mm, dy=8mm, dz=5mm, Reference Value = 9.755 V/m; Power Drift = 0.15 dB

Peak SAR (extrapolated) = 0.420 mW/g

SAR(1 g) = 0.174 mW/g; SAR(10 g) = 0.070 mW/g Maximum value of SAR (measured) = 0.205 mW/g

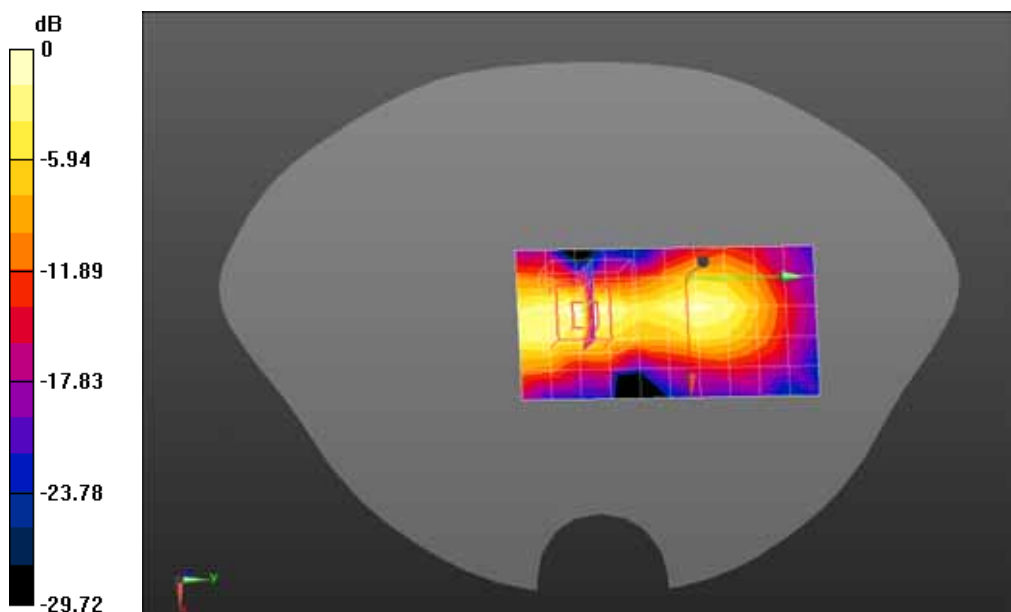

0 dB = 0.205 mW/g = -13.76 dB mW/g

Date/Time: 10-03-2014

Test Laboratory: QuieTek Lab

802.11b 2457MHz Vertical back-ant 0

DUT: IP-STB; Type: 3500X

Communication System: Wi-Fi; Communication System Band: 802.11b; Duty Cycle: 1:1.0; Frequency: 2457 MHz; Medium parameters used: $f = 2457$ MHz; $\sigma = 2$ mho/m; $\epsilon_r = 52.23$; $\rho = 1000$ kg/m³; Phantom section: Flat Section

Ambient temperature (): 21.5, Liquid temperature (): 21.0

DASY5 Configuration:

- Probe: EX3DV4 - SN3962; ConvF(7.13, 7.13, 7.13); Calibrated: 10/12/2013;
- Sensor-Surface: 4mm (Mechanical Surface Detection)
- Electronics: DAE4 Sn1220; Calibrated: 22/01/2014
- Phantom: SAM1; Type: SAM; Serial: TP1561
- Measurement SW: DASY52, Version 52.8 (1); SEMCAD X Version 14.6.5 (6469)

Configuration/802.11b 2457MHz Vertical back/Area Scan (6x11x1): Measurement grid: dx=12mm, dy=12mm

Maximum value of SAR (measured) = 0.310 mW/g

Configuration/802.11b 2457MHz Vertical back/Zoom Scan (5x5x7)/Cube 0: Measurement grid: dx=8mm, dy=8mm, dz=5mm, Reference Value = 12.684 V/m; Power Drift = 0.15 dB

Peak SAR (extrapolated) = 0.690 mW/g

SAR(1 g) = 0.301 mW/g; SAR(10 g) = 0.123 mW/g Maximum value of SAR (measured) = 0.357 mW/g

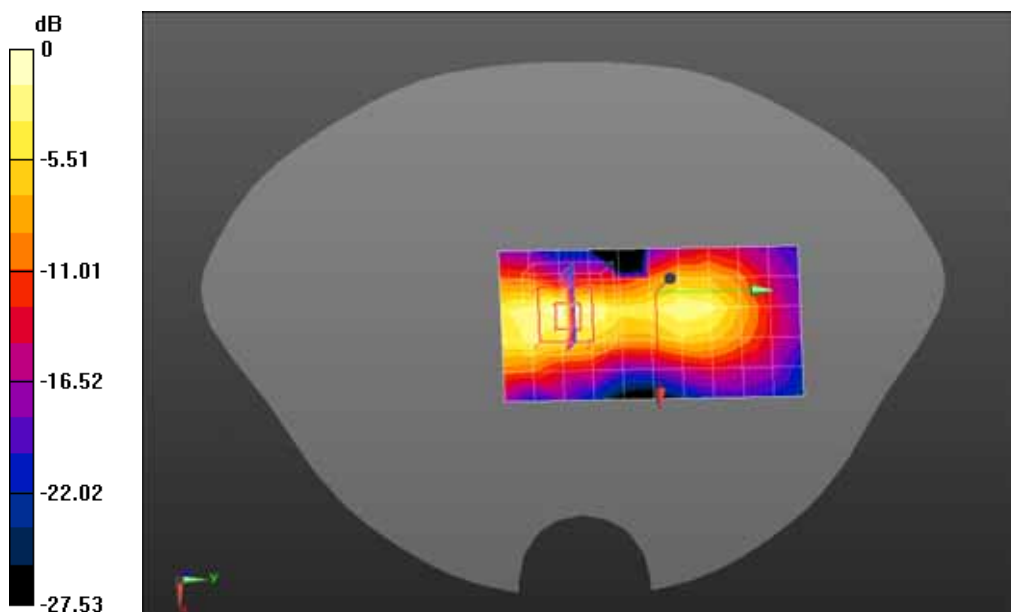

0 dB = 0.357 mW/g = -8.95 dB mW/g

Date/Time: 10-03-2014

Test Laboratory: QuieTek Lab

802.11b 2412MHz Tip-ant 0

DUT: IP-STB; Type: 3500X

Communication System: Wi-Fi; Communication System Band: 802.11b; Duty Cycle: 1:1.0; Frequency: 2412 MHz; Medium parameters used: $f = 2412$ MHz; $\sigma = 1.92$ mho/m; $\epsilon_r = 52.49$; $\rho = 1000$ kg/m³ ; Phantom section: Flat Section

Ambient temperature (): 21.5, Liquid temperature (): 21.0

DASY5 Configuration:

- Probe: EX3DV4 - SN3962; ConvF(7.13, 7.13, 7.13); Calibrated: 10/12/2013;
- Sensor-Surface: 4mm (Mechanical Surface Detection)
- Electronics: DAE4 Sn1220; Calibrated: 22/01/2014
- Phantom: SAM1; Type: SAM; Serial: TP1561
- Measurement SW: DASY52, Version 52.8 (1); SEMCAD X Version 14.6.5 (6469)

Configuration/802.11b 2412MHz Tip/Area Scan (6x6x1): Measurement grid: dx=12mm, dy=12mm

Maximum value of SAR (measured) = 0.232 mW/g

Configuration/802.11b 2412MHz Tip/Zoom Scan (5x5x7)/Cube 0: Measurement grid: dx=8mm, dy=8mm, dz=5mm, Reference Value = 5.895 V/m; Power Drift = 0.04 dB

Peak SAR (extrapolated) = 0.448 mW/g

SAR(1 g) = 0.203 mW/g; SAR(10 g) = 0.089 mW/g, Maximum value of SAR (measured) = 0.224 mW/g

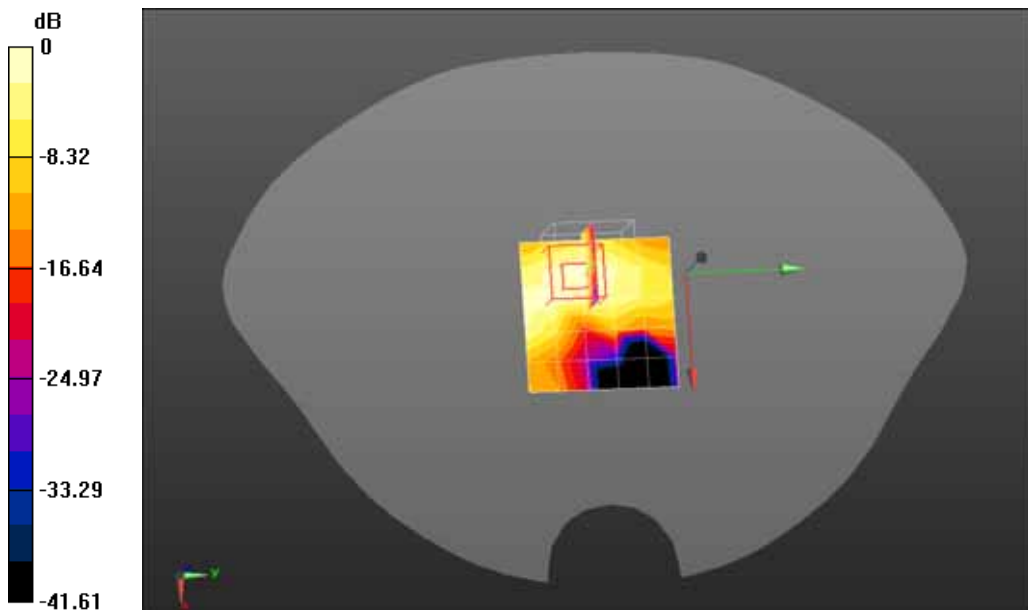

0 dB = 0.224 mW/g = -13.00 dB mW/g

Date/Time: 10-03-2014

Test Laboratory: QuieTek Lab

802.11b 2412MHz Vertical back-ant 1

DUT: IP-STB; Type: 3500X

Communication System: Wi-Fi; Communication System Band: 802.11b; Duty Cycle: 1:1.0; Frequency: 2412 MHz; Medium parameters used: $f = 2412$ MHz; $\sigma = 1.92$ mho/m; $\epsilon_r = 52.49$; $\rho = 1000$ kg/m³; Phantom section: Flat Section

Ambient temperature (): 21.5, Liquid temperature (): 21.0

DASY5 Configuration:

- Probe: EX3DV4 - SN3962; ConvF(7.13, 7.13, 7.13); Calibrated: 10/12/2013;
- Sensor-Surface: 4mm (Mechanical Surface Detection)
- Electronics: DAE4 Sn1220; Calibrated: 22/01/2014
- Phantom: SAM1; Type: SAM; Serial: TP1561
- Measurement SW: DASY52, Version 52.8 (1); SEMCAD X Version 14.6.5 (6469)

Configuration/802.11b 2412MHz Vertical back/Area Scan (6x11x1): Measurement grid: dx=12mm, dy=12mm

Maximum value of SAR (measured) = 0.129 mW/g

Configuration/802.11b 2412MHz Vertical back/Zoom Scan (5x5x7)/Cube 0: Measurement grid: dx=8mm, dy=8mm, dz=5mm, Reference Value = 1.538 V/m; Power Drift = 0.01 dB

Peak SAR (extrapolated) = 0.233 mW/g

SAR(1 g) = 0.116 mW/g; SAR(10 g) = 0.054 mW/g Maximum value of SAR (measured) = 0.134 mW/g

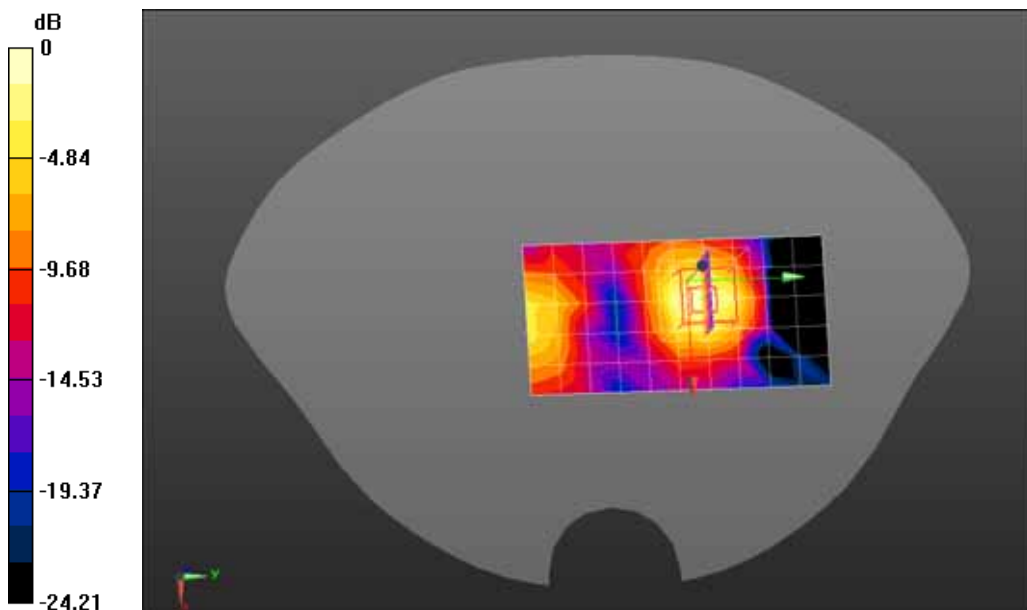

0 dB = 0.134 mW/g = -17.46 dB mW/g

Date/Time: 10-03-2014

Test Laboratory: QuieTek Lab

802.11g 2412MHz Vertical back-ant 0

DUT: IP-STB; Type: 3500X

Communication System: Wi-Fi; Communication System Band: 802.11g; Duty Cycle: 1:1.0; Frequency: 2412 MHz; Medium parameters used: $f = 2412$ MHz; $\sigma = 1.92$ mho/m; $\epsilon_r = 52.49$; $\rho = 1000$ kg/m³; Phantom section: Flat Section

Ambient temperature (): 21.5, Liquid temperature (): 21.0

DASY5 Configuration:

- Probe: EX3DV4 - SN3962; ConvF(7.13, 7.13, 7.13); Calibrated: 10/12/2013;
- Sensor-Surface: 4mm (Mechanical Surface Detection)
- Electronics: DAE4 Sn1220; Calibrated: 22/01/2014
- Phantom: SAM1; Type: SAM; Serial: TP1561
- Measurement SW: DASY52, Version 52.8 (1); SEMCAD X Version 14.6.5 (6469)

Configuration/802.11g 2412MHz Vertical back/Area Scan (6x11x1): Measurement grid: dx=12mm, dy=12mm

Maximum value of SAR (measured) = 0.153 mW/g

Configuration/802.11g 2412MHz Vertical back/Zoom Scan (5x5x7)/Cube 0: Measurement grid: dx=8mm, dy=8mm, dz=5mm, Reference Value = 8.897 V/m; Power Drift = 0.12 dB

Peak SAR (extrapolated) = 0.421 mW/g

SAR(1 g) = 0.150 mW/g; SAR(10 g) = 0.061 mW/g Maximum value of SAR (measured) = 0.170 mW/g

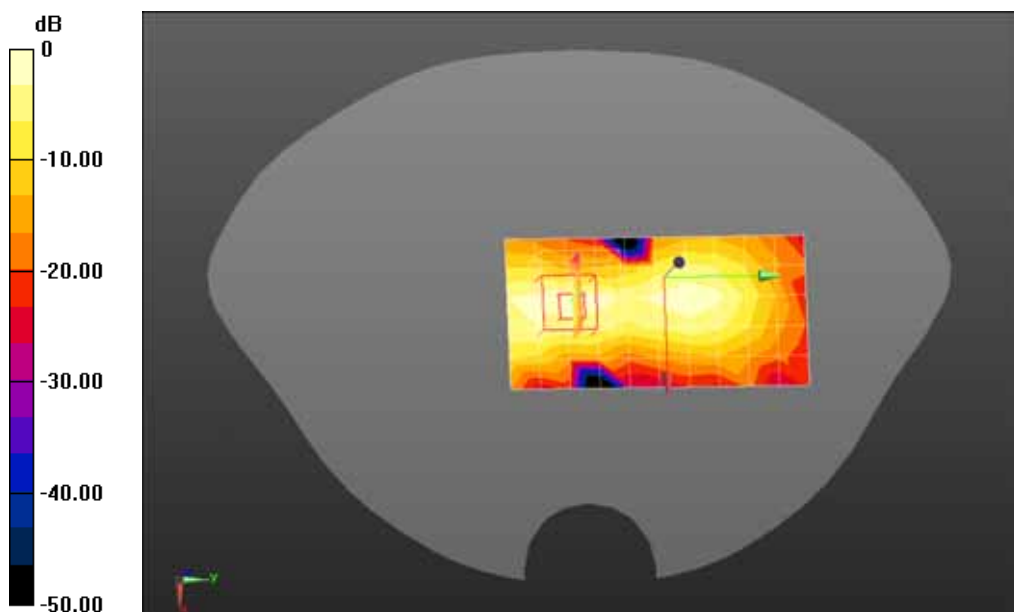

0 dB = 0.170 mW/g = -15.39 dB mW/g

Date/Time: 10-03-2014

Test Laboratory: QuieTek Lab

802.11g 2437MHz Vertical back-ant 0

DUT: IP-STB; Type: 3500X

Communication System: Wi-Fi; Communication System Band: 802.11g; Duty Cycle: 1:1.0; Frequency: 2437 MHz; Medium parameters used: $f = 2437$ MHz; $\sigma = 1.96$ mho/m; $\epsilon_r = 52.3$; $\rho = 1000$ kg/m³; Phantom section: Flat Section

Ambient temperature (): 21.5, Liquid temperature (): 21.0

DASY5 Configuration:

- Probe: EX3DV4 - SN3962; ConvF(7.13, 7.13, 7.13); Calibrated: 10/12/2013;
- Sensor-Surface: 4mm (Mechanical Surface Detection)
- Electronics: DAE4 Sn1220; Calibrated: 22/01/2014
- Phantom: SAM1; Type: SAM; Serial: TP1561
- Measurement SW: DASY52, Version 52.8 (1); SEMCAD X Version 14.6.5 (6469)

Configuration/802.11g 2437MHz Vertical back/Area Scan (6x11x1): Measurement grid: dx=12mm, dy=12mm

Maximum value of SAR (measured) = 0.179 mW/g

Configuration/802.11g 2437MHz Vertical back/Zoom Scan (5x5x7)/Cube 0: Measurement grid: dx=8mm, dy=8mm, dz=5mm, Reference Value = 9.644 V/m; Power Drift = 0.07 dB

Peak SAR (extrapolated) = 0.413 mW/g

SAR(1 g) = 0.173 mW/g; SAR(10 g) = 0.070 mW/g Maximum value of SAR (measured) = 0.206 mW/g

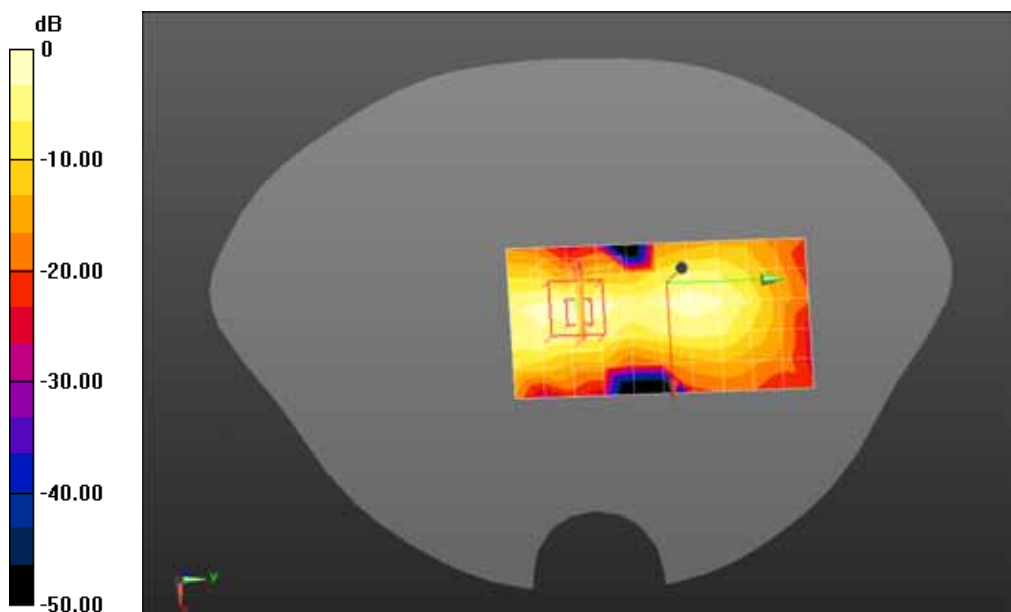

0 dB = 0.206 mW/g = -13.72 dB mW/g

Date/Time: 10-03-2014

Test Laboratory: QuieTek Lab

802.11g 2462MHz Vertical back-ant 0

DUT: IP-STB; Type: 3500X

Communication System: Wi-Fi; Communication System Band: 802.11g; Duty Cycle: 1:1.0; Frequency: 2462 MHz; Medium parameters used: $f = 2462$ MHz; $\sigma = 2.01$ mho/m; $\epsilon_r = 52.21$; $\rho = 1000$ kg/m³; Phantom section: Flat Section

Ambient temperature (): 21.5, Liquid temperature (): 21.0

DASY5 Configuration:

- Probe: EX3DV4 - SN3962; ConvF(7.13, 7.13, 7.13); Calibrated: 10/12/2013;
- Sensor-Surface: 4mm (Mechanical Surface Detection)
- Electronics: DAE4 Sn1220; Calibrated: 22/01/2014
- Phantom: SAM1; Type: SAM; Serial: TP1561
- Measurement SW: DASY52, Version 52.8 (1); SEMCAD X Version 14.6.5 (6469)

Configuration/802.11g 2462MHz Vertical back/Area Scan (6x11x1): Measurement grid: dx=12mm, dy=12mm

Maximum value of SAR (measured) = 0.187 mW/g

Configuration/802.11g 2462MHz Vertical back/Zoom Scan (5x5x7)/Cube 0: Measurement grid: dx=8mm, dy=8mm, dz=5mm, Reference Value = 9.820 V/m; Power Drift = -0.06 dB

Peak SAR (extrapolated) = 0.379 mW/g

SAR(1 g) = 0.170 mW/g; SAR(10 g) = 0.070 mW/g Maximum value of SAR (measured) = 0.205 mW/g

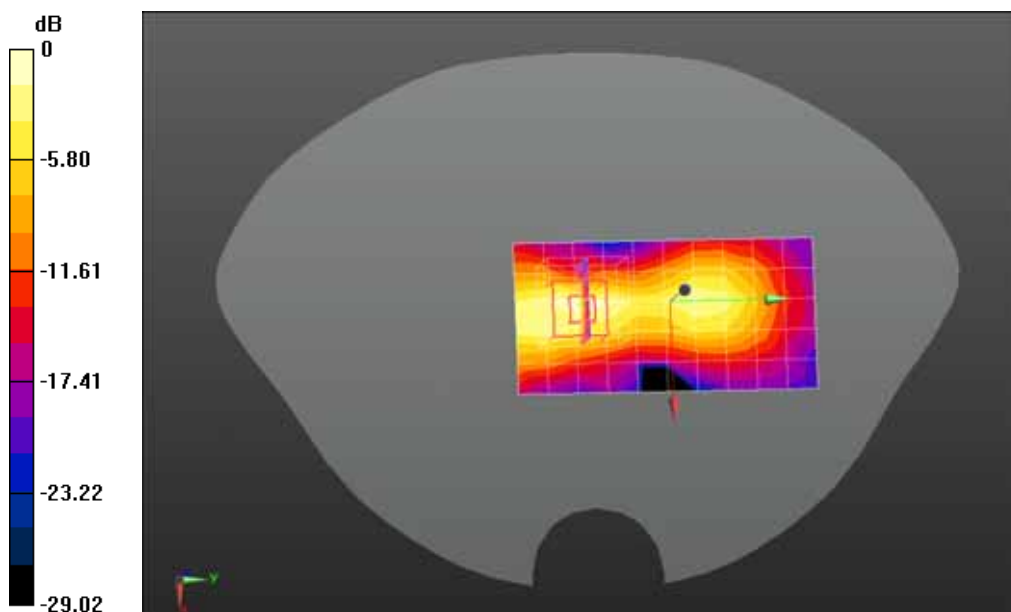

0 dB = 0.205 mW/g = -13.76 dB mW/g

Date/Time: 10-03-2014

Test Laboratory: QuieTek Lab

802.11n(20MHz) 2412MHz Vertical back-ant (0+1)

DUT: IP-STB; Type: 3500X

Communication System: Wi-Fi; Communication System Band: 802.11n(20MHz); Duty Cycle: 1:1.0;

Frequency: 2412 MHz; Medium parameters used: $f = 2412$ MHz; $\sigma = 1.92$ mho/m; $\epsilon_r = 52.49$; $\rho = 1000$

kg/m³ ; Phantom section: Flat Section

Ambient temperature (): 21.5, Liquid temperature (): 21.0

DASY5 Configuration:

- Probe: EX3DV4 - SN3962; ConvF(7.13, 7.13, 7.13); Calibrated: 10/12/2013;
- Sensor-Surface: 4mm (Mechanical Surface Detection)
- Electronics: DAE4 Sn1220; Calibrated: 22/01/2014
- Phantom: SAM1; Type: SAM; Serial: TP1561
- Measurement SW: DASY52, Version 52.8 (1); SEMCAD X Version 14.6.5 (6469)

Configuration/802.11n(20MHz) 2412MHz Vertical back/Area Scan (6x11x1): Measurement grid:

dx=12mm, dy=12mm

Maximum value of SAR (measured) = 0.0917 mW/g

Configuration/802.11n(20MHz) 2412MHz Vertical back/Zoom Scan (5x5x7)/Cube 0: Measurement grid:

dx=8mm, dy=8mm, dz=5mm, Reference Value = 5.817 V/m; Power Drift = 0.04 dB

Peak SAR (extrapolated) = 0.149 mW/g

SAR(1 g) = 0.079 mW/g; SAR(10 g) = 0.037 mW/g Maximum value of SAR (measured) = 0.0924 mW/g

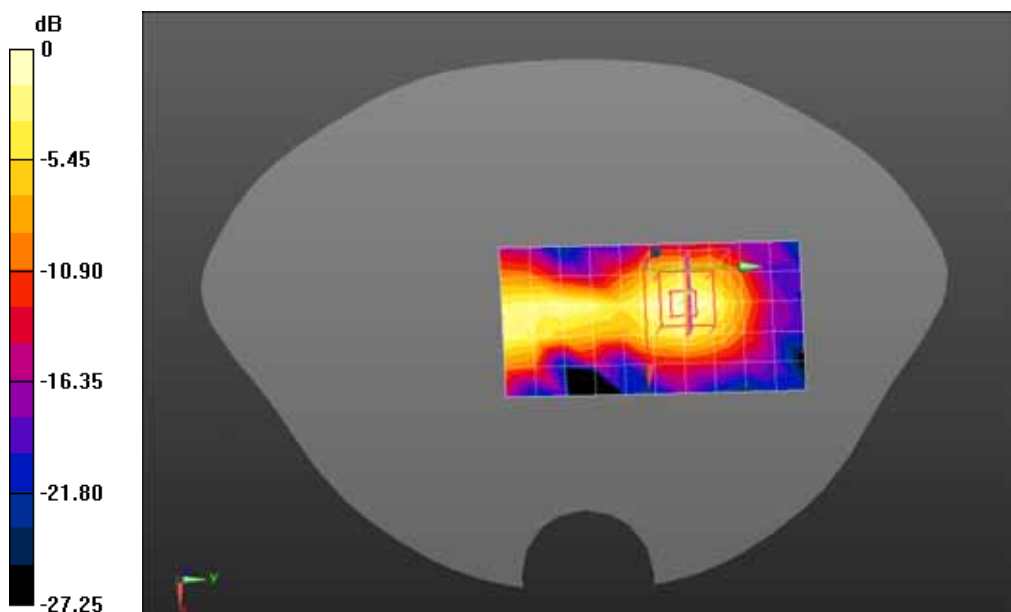

0 dB = 0.0924 mW/g = -20.69 dB mW/g

Date/Time: 10-03-2014

Test Laboratory: QuieTek Lab

802.11n(20MHz) 2437MHz Vertical back-ant (0+1)

DUT: IP-STB; Type: 3500X

Communication System: Wi-Fi; Communication System Band: 802.11n(20MHz); Duty Cycle: 1:1.0;

Frequency: 2437 MHz; Medium parameters used: $f = 2437$ MHz; $\sigma = 1.96$ mho/m; $\epsilon_r = 52.3$; $\rho = 1000$ kg/m³ ;

Phantom section: Flat Section

Ambient temperature (): 21.5, Liquid temperature (): 21.0

DASY5 Configuration:

- Probe: EX3DV4 - SN3962; ConvF(7.13, 7.13, 7.13); Calibrated: 10/12/2013;
- Sensor-Surface: 4mm (Mechanical Surface Detection)
- Electronics: DAE4 Sn1220; Calibrated: 22/01/2014
- Phantom: SAM1; Type: SAM; Serial: TP1561
- Measurement SW: DASY52, Version 52.8 (1); SEMCAD X Version 14.6.5 (6469)

Configuration/802.11n(20MHz) 2437MHz Vertical back/Area Scan (6x11x1): Measurement grid:

dx=12mm, dy=12mm

Maximum value of SAR (measured) = 0.397 mW/g

Configuration/802.11n(20MHz) 2437MHz Vertical back/Zoom Scan (5x5x7)/Cube 0: Measurement grid:

dx=8mm, dy=8mm, dz=5mm, Reference Value = 13.916 V/m; Power Drift = -0.07 dB

Peak SAR (extrapolated) = 0.764 mW/g

SAR(1 g) = 0.347 mW/g; SAR(10 g) = 0.149 mW/g, Maximum value of SAR (measured) = 0.432 mW/g

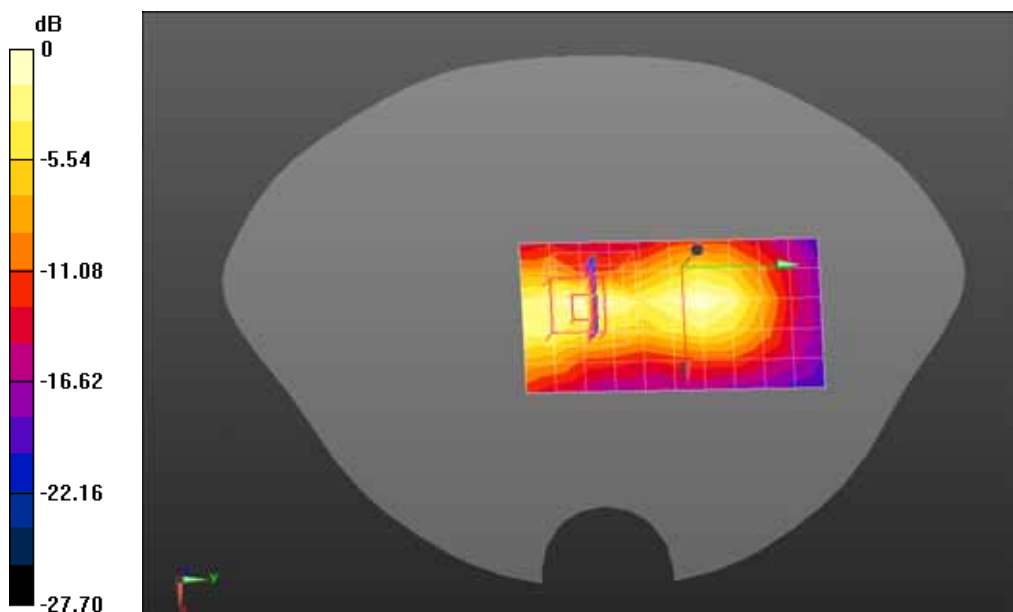

0 dB = 0.432 mW/g = -7.29 dB mW/g

Z-Axis Plot

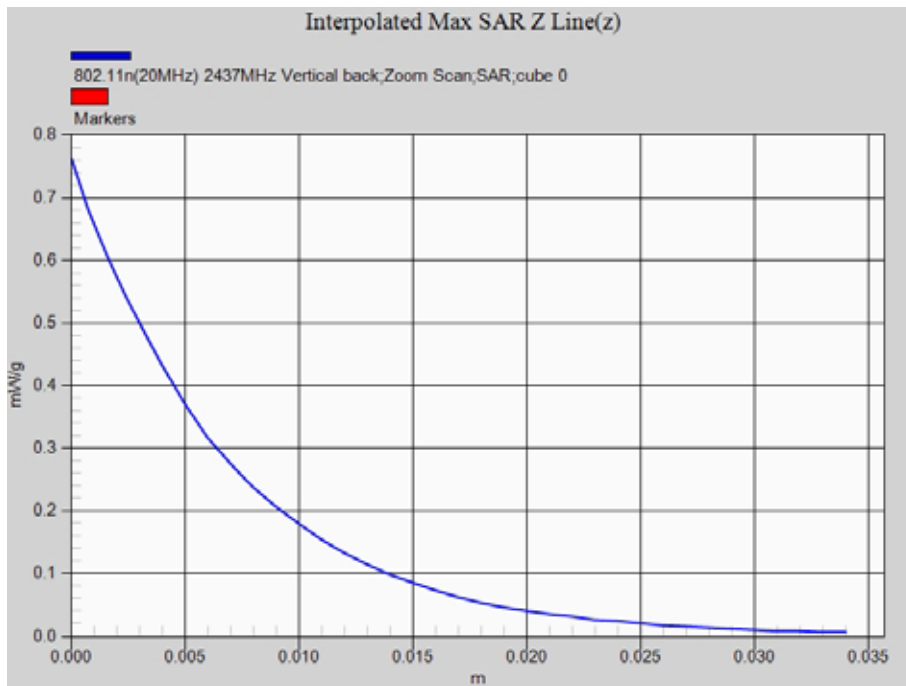

Date/Time: 10-03-2014

Test Laboratory: QuieTek Lab

802.11n(20MHz) 2462MHz Vertical back-ant (0+1)

DUT: IP-STB; Type: 3500X

Communication System: Wi-Fi; Communication System Band: 802.11n(20MHz); Duty Cycle: 1:1.0;

Frequency: 2462 MHz; Medium parameters used: $f = 2462 \text{ MHz}$; $\sigma = 2.01 \text{ mho/m}$; $\epsilon_r = 52.21$; $\rho = 1000$

kg/m³ ; Phantom section: Flat Section

Ambient temperature (): 21.5, Liquid temperature (): 21.0

DASY5 Configuration:

- Probe: EX3DV4 - SN3962; ConvF(7.13, 7.13, 7.13); Calibrated: 10/12/2013;
- Sensor-Surface: 4mm (Mechanical Surface Detection)
- Electronics: DAE4 Sn1220; Calibrated: 22/01/2014
- Phantom: SAM1; Type: SAM; Serial: TP1561
- Measurement SW: DASY52, Version 52.8 (1); SEMCAD X Version 14.6.5 (6469)

Configuration/802.11n(20MHz) 2462MHz Vertical back/Area Scan (6x11x1): Measurement grid:

dx=12mm, dy=12mm

Maximum value of SAR (measured) = 0.158 mW/g

Configuration/802.11n(20MHz) 2462MHz Vertical back/Zoom Scan (5x5x7)/Cube 0: Measurement grid:

dx=8mm, dy=8mm, dz=5mm, Reference Value = 8.741 V/m; Power Drift = 0.17 dB

Peak SAR (extrapolated) = 0.296 mW/g

SAR(1 g) = 0.143 mW/g; SAR(10 g) = 0.060 mW/g Maximum value of SAR (measured) = 0.181 mW/g

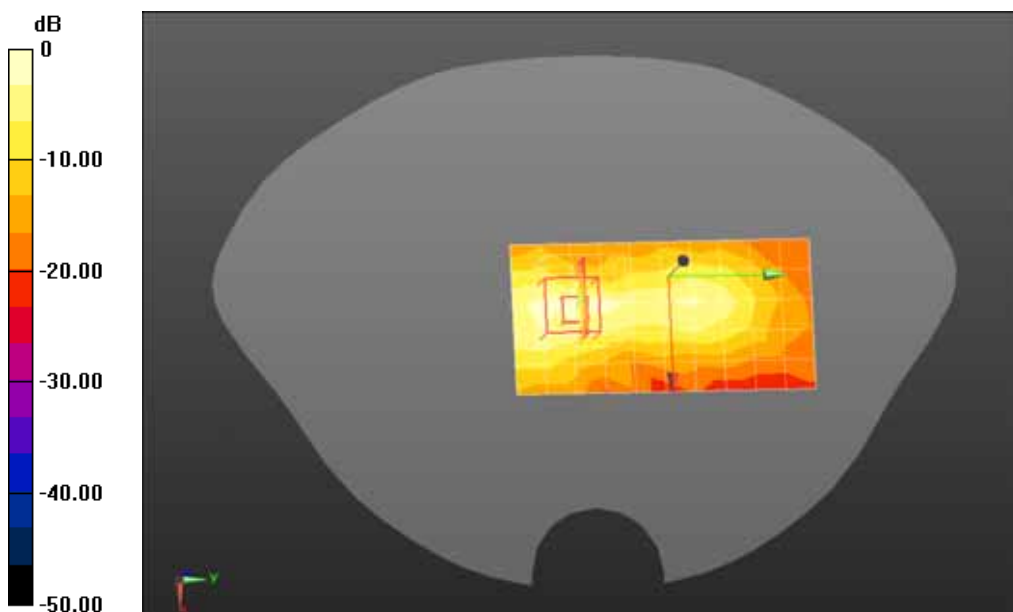

0 dB = 0.181 mW/g = -14.85 dB mW/g

Date/Time: 10-03-2014

Test Laboratory: QuieTek Lab

802.11n(40MHz) 2422MHz Vertical back-ant (0+1)

DUT: IP-STB; Type: 3500X

Communication System: Wi-Fi; Communication System Band: 802.11n(40MHz); Duty Cycle: 1:1.0;

Frequency: 2422 MHz; Medium parameters used: $f = 2422$ MHz; $\sigma = 1.94$ mho/m; $\epsilon_r = 52.45$; $\rho = 1000$

kg/m³ ; Phantom section: Flat Section

Ambient temperature (): 21.5, Liquid temperature (): 21.0

DASY5 Configuration:

- Probe: EX3DV4 - SN3962; ConvF(7.13, 7.13, 7.13); Calibrated: 10/12/2013;
- Sensor-Surface: 4mm (Mechanical Surface Detection)
- Electronics: DAE4 Sn1220; Calibrated: 22/01/2014
- Phantom: SAM1; Type: SAM; Serial: TP1561
- Measurement SW: DASY52, Version 52.8 (1); SEMCAD X Version 14.6.5 (6469)

Configuration/802.11n(40MHz) 2422MHz Vertical back/Area Scan (6x11x1): Measurement grid:

dx=12mm, dy=12mm

Maximum value of SAR (measured) = 0.0579 mW/g

Configuration/802.11n(40MHz) 2422MHz Vertical back/Zoom Scan (5x5x7)/Cube 0: Measurement grid:

dx=8mm, dy=8mm, dz=5mm, Reference Value = 4.768 V/m; Power Drift = 0.14 dB

Peak SAR (extrapolated) = 0.098 mW/g

SAR(1 g) = 0.052 mW/g; SAR(10 g) = 0.024 mW/g Maximum value of SAR (measured) = 0.0612 mW/g

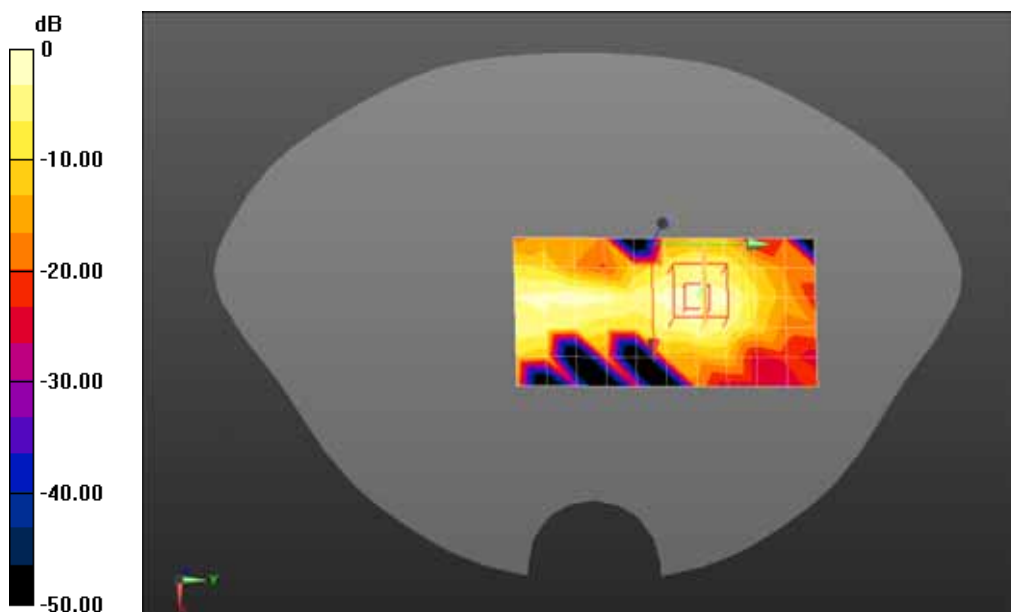

0 dB = 0.0612 mW/g = -24.26 dB mW/g

Date/Time: 10-03-2014

Test Laboratory: QuieTek Lab

802.11n(40MHz) 2437MHz Vertical back-ant (0+1)

DUT: IP-STB; Type: 3500X

Communication System: Wi-Fi; Communication System Band: 802.11n(40MHz); Duty Cycle: 1:1.0;

Frequency: 2437 MHz; Medium parameters used: $f = 2437$ MHz; $\sigma = 1.96$ mho/m; $\epsilon_r = 52.3$; $\rho = 1000$ kg/m³ ;

Phantom section: Flat Section

Ambient temperature (): 21.5, Liquid temperature (): 21.0

DASY5 Configuration:

- Probe: EX3DV4 - SN3962; ConvF(7.13, 7.13, 7.13); Calibrated: 10/12/2013;
- Sensor-Surface: 4mm (Mechanical Surface Detection)
- Electronics: DAE4 Sn1220; Calibrated: 22/01/2014
- Phantom: SAM1; Type: SAM; Serial: TP1561
- Measurement SW: DASY52, Version 52.8 (1); SEMCAD X Version 14.6.5 (6469)

Configuration/802.11n(40MHz) 2437MHz Vertical back/Area Scan (6x11x1): Measurement grid:

dx=12mm, dy=12mm

Maximum value of SAR (measured) = 0.241 mW/g

Configuration/802.11n(40MHz) 2437MHz Vertical back/Zoom Scan (5x5x7)/Cube 0: Measurement grid:

dx=8mm, dy=8mm, dz=5mm, Reference Value = 10.230 V/m; Power Drift = 0.18 dB

Peak SAR (extrapolated) = 0.449 mW/g

SAR(1 g) = 0.207 mW/g; SAR(10 g) = 0.089 mW/g Maximum value of SAR (measured) = 0.253 mW/g

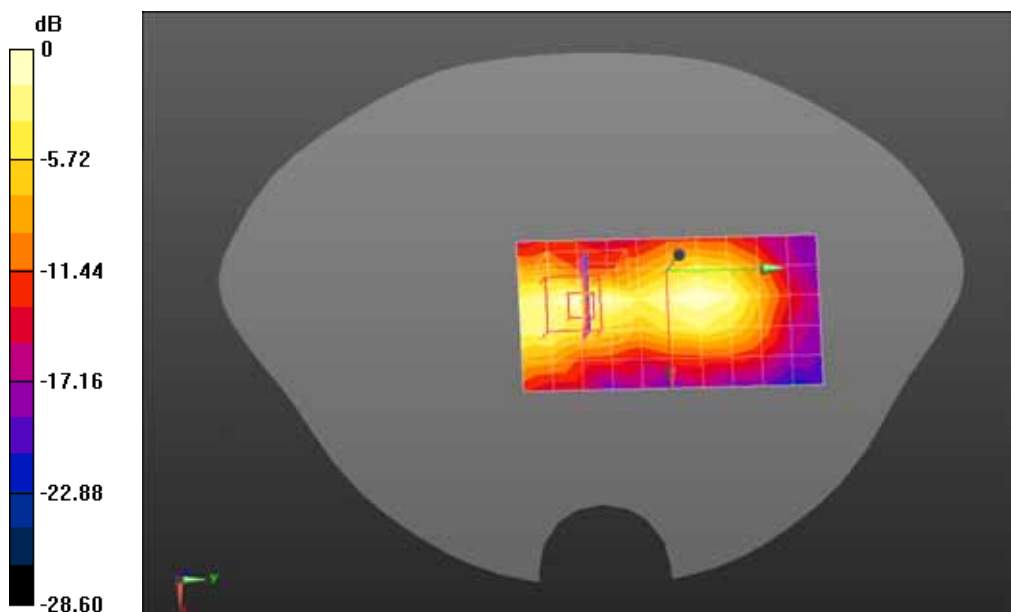

0 dB = 0.253 mW/g = -11.94 dB mW/g

Date/Time: 10-03-2014

Test Laboratory: QuieTek Lab

802.11n(40MHz) 2452MHz Vertical back-ant (0+1)

DUT: IP-STB; Type: 3500X

Communication System: Wi-Fi; Communication System Band: 802.11n(40MHz); Duty Cycle: 1:1.0;

Frequency: 2452 MHz; Medium parameters used: $f = 2452$ MHz; $\sigma = 2$ mho/m; $\epsilon_r = 52.25$; $\rho = 1000$ kg/m³ ;

Phantom section: Flat Section

Ambient temperature (): 21.5, Liquid temperature (): 21.0

DASY5 Configuration:

- Probe: EX3DV4 - SN3962; ConvF(7.13, 7.13, 7.13); Calibrated: 10/12/2013;
- Sensor-Surface: 4mm (Mechanical Surface Detection)
- Electronics: DAE4 Sn1220; Calibrated: 22/01/2014
- Phantom: SAM1; Type: SAM; Serial: TP1561
- Measurement SW: DASY52, Version 52.8 (1); SEMCAD X Version 14.6.5 (6469)

Configuration/802.11n(40MHz) 2452MHz Vertical back/Area Scan (6x11x1): Measurement grid:

dx=12mm, dy=12mm

Maximum value of SAR (measured) = 0.0915 mW/g

Configuration/802.11n(40MHz) 2452MHz Vertical back/Zoom Scan (5x5x7)/Cube 0: Measurement grid:

dx=8mm, dy=8mm, dz=5mm, Reference Value = 6.669 V/m; Power Drift = 0.01 dB

Peak SAR (extrapolated) = 0.217 mW/g

SAR(1 g) = 0.086 mW/g; SAR(10 g) = 0.035 mW/g Maximum value of SAR (measured) = 0.102 mW/g

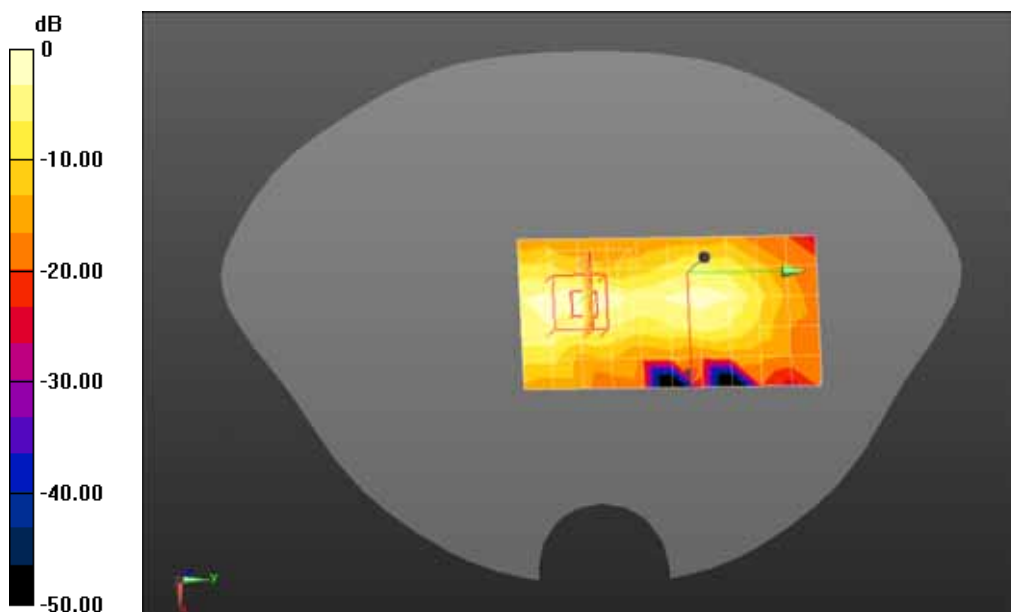

0 dB = 0.102 mW/g = -19.83 dB mW/g

Date/Time: 10-03-2014

Test Laboratory: QuieTek Lab

802.11a 5200MHz Horizontal up-ant 1

DUT: IP-STB; Type: 3500X

Communication System: CW; Communication System Band: 5GHz(5000.0-6000.0MHz); Duty Cycle: 1:1.0;
 Frequency: 5200 MHz; Medium parameters used: $f = 5200 \text{ MHz}$; $\sigma = 5.15 \text{ mho/m}$; $\epsilon_r = 48.94$; $\rho = 1000 \text{ kg/m}^3$; Phantom section: Flat Section

Ambient temperature (): 21.5, Liquid temperature (): 21.0

DASY5 Configuration:

- Probe: EX3DV4 - SN3962; ConvF(4.18, 4.18, 4.18); Calibrated: 10/12/2013;
- Sensor-Surface: 2mm (Mechanical Surface Detection)
- Electronics: DAE4 Sn1220; Calibrated: 22/01/2014
- Phantom: SAM1; Type: SAM; Serial: TP1561
- Measurement SW: DASY52, Version 52.8 (1); SEMCAD X Version 14.6.5 (6469)

Configuration/802.11a 5200MHz Horizontal up/Area Scan (7x13x1): Measurement grid: dx=10mm, dy=10mm

Maximum value of SAR (measured) = 1.02 mW/g

Configuration/802.11a 5200MHz Horizontal up/Zoom Scan (6x6x6)/Cube 0: Measurement grid: dx=5mm, dy=5mm, dz=2mm, Reference Value = 4.838 V/m; Power Drift = 0.03 dB

Peak SAR (extrapolated) = 2.473 mW/g

SAR(1 g) = 0.657 mW/g; SAR(10 g) = 0.208 mW/g, Maximum value of SAR (measured) = 1.29 mW/g

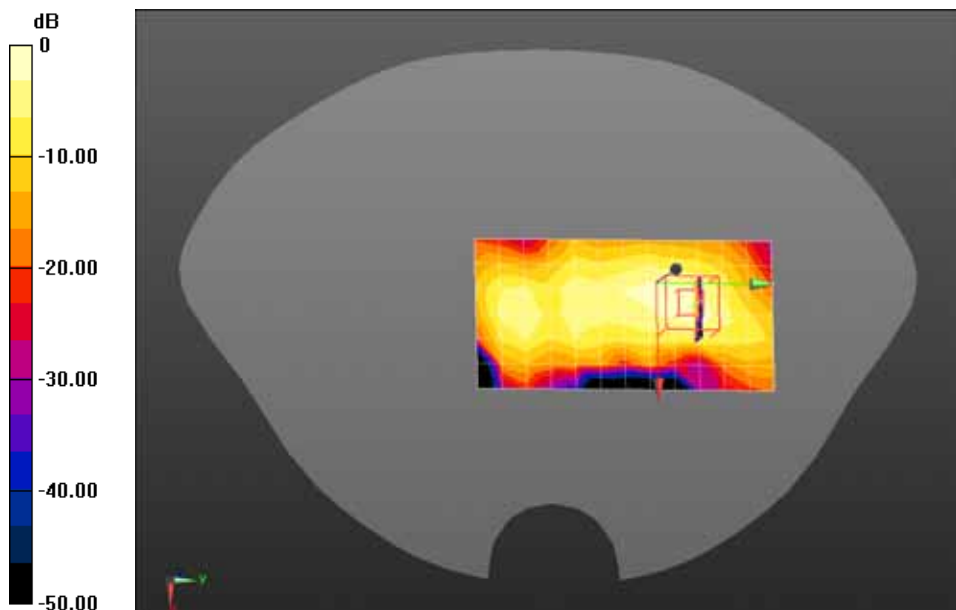

0 dB = 1.29 mW/g = 2.21 dB mW/g

Date/Time: 10-03-2014

Test Laboratory: QuieTek Lab

802.11a 5200MHz Horizontal down-ant 1

DUT: IP-STB; Type: 3500X

Communication System: CW; Communication System Band: 5GHz(5000.0-6000.0MHz); Duty Cycle: 1:1.0;
 Frequency: 5200 MHz; Medium parameters used: $f = 5200$ MHz; $\sigma = 5.15$ mho/m; $\epsilon_r = 48.94$; $\rho = 1000$ kg/m³ ; Phantom section: Flat Section

Ambient temperature (): 21.5, Liquid temperature (): 21.0

DASY5 Configuration:

- Probe: EX3DV4 - SN3962; ConvF(4.18, 4.18, 4.18); Calibrated: 10/12/2013;
- Sensor-Surface: 2mm (Mechanical Surface Detection)
- Electronics: DAE4 Sn1220; Calibrated: 22/01/2014
- Phantom: SAM1; Type: SAM; Serial: TP1561
- Measurement SW: DASY52, Version 52.8 (1); SEMCAD X Version 14.6.5 (6469)

Configuration/802.11a 5200MHz Horizontal down/Area Scan (7x13x1): Measurement grid: dx=10mm, dy=10mm

Maximum value of SAR (measured) = 1.21 mW/g

Configuration/802.11a 5200MHz Horizontal down/Zoom Scan (6x6x6)/Cube 0: Measurement grid: dx=5mm, dy=5mm, dz=2mm, Reference Value = 7.740 V/m; Power Drift = 0.08 dB

Peak SAR (extrapolated) = 2.501 mW/g

SAR(1 g) = 0.710 mW/g; SAR(10 g) = 0.258 mW/g, Maximum value of SAR (measured) = 1.32 mW/g

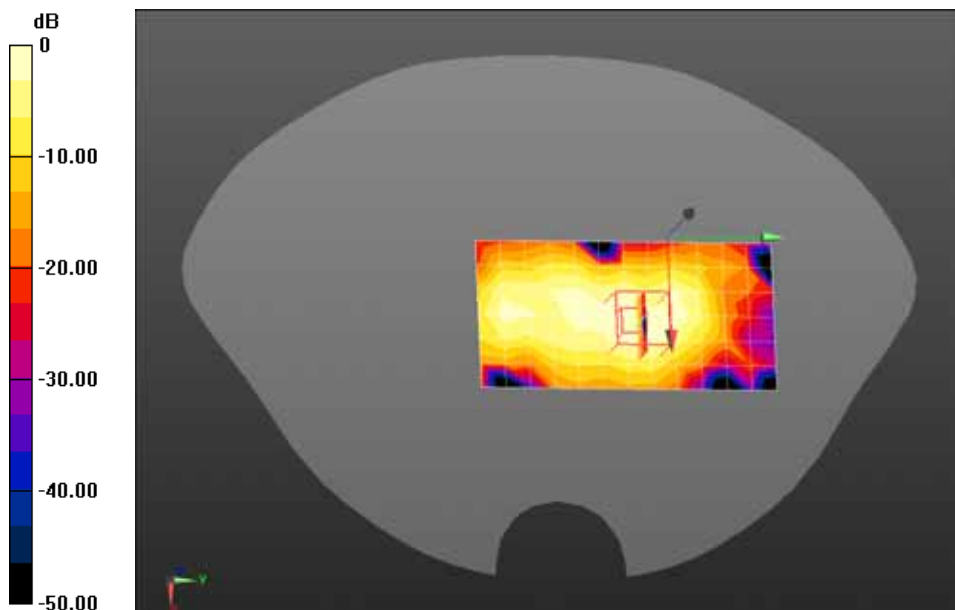

0 dB = 1.32 mW/g = 2.41 dB mW/g

Date/Time: 10-03-2014

Test Laboratory: QuieTek Lab

802.11a 5200MHz Vertical Front-ant 1

DUT: IP-STB; Type: 3500X

Communication System: CW; Communication System Band: 5GHz(5000.0-6000.0MHz); Duty Cycle: 1:1.0;
 Frequency: 5200 MHz; Medium parameters used: $f = 5200 \text{ MHz}$; $\sigma = 5.15 \text{ mho/m}$; $\epsilon_r = 48.94$; $\rho = 1000 \text{ kg/m}^3$; Phantom section: Flat Section

Ambient temperature (): 21.5, Liquid temperature (): 21.0

DASY5 Configuration:

- Probe: EX3DV4 - SN3962; ConvF(4.18, 4.18, 4.18); Calibrated: 10/12/2013;
- Sensor-Surface: 2mm (Mechanical Surface Detection)
- Electronics: DAE4 Sn1220; Calibrated: 22/01/2014
- Phantom: SAM1; Type: SAM; Serial: TP1561
- Measurement SW: DASY52, Version 52.8 (1); SEMCAD X Version 14.6.5 (6469)

Configuration/802.11a 5200MHz Vertical Front/Area Scan (7x13x1): Measurement grid: dx=10mm, dy=10mm

Maximum value of SAR (measured) = 1.60 mW/g

Configuration/802.11a 5200MHz Vertical Front/Zoom Scan (6x6x6)/Cube 0: Measurement grid: dx=5mm, dy=5mm, dz=2mm, Reference Value = 13.486 V/m; Power Drift = 0.02 dB

Peak SAR (extrapolated) = 3.334 mW/g

SAR(1 g) = 0.975 mW/g; SAR(10 g) = 0.337 mW/g, Maximum value of SAR (measured) = 1.84 mW/g

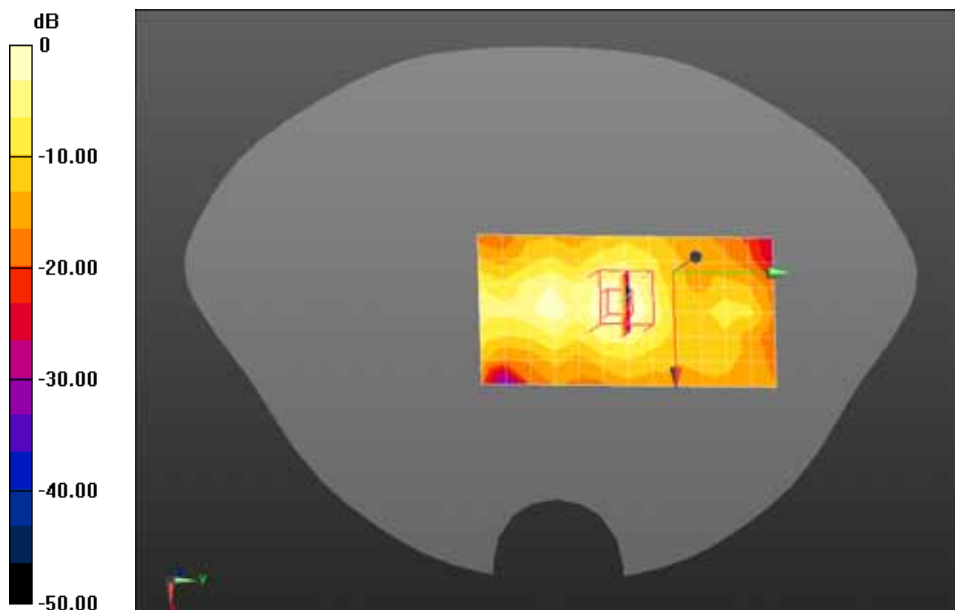

0 dB = 1.84 mW/g = 5.30 dB mW/g

Date/Time: 10-03-2014

Test Laboratory: QuieTek Lab

802.11a 5200MHz Vertical back-ant 1

DUT: IP-STB; Type: 3500X

Communication System: CW; Communication System Band: 5GHz(5000.0-6000.0MHz); Duty Cycle: 1:1.0;
 Frequency: 5200 MHz; Medium parameters used: $f = 5200 \text{ MHz}$; $\sigma = 5.15 \text{ mho/m}$; $\epsilon_r = 48.94$; $\rho = 1000 \text{ kg/m}^3$; Phantom section: Flat Section

Ambient temperature (): 21.5, Liquid temperature (): 21.0

DASY5 Configuration:

- Probe: EX3DV4 - SN3962; ConvF(4.18, 4.18, 4.18); Calibrated: 10/12/2013;
- Sensor-Surface: 2mm (Mechanical Surface Detection)
- Electronics: DAE4 Sn1220; Calibrated: 22/01/2014
- Phantom: SAM1; Type: SAM; Serial: TP1561
- Measurement SW: DASY52, Version 52.8 (1); SEMCAD X Version 14.6.5 (6469)

Configuration/802.11a 5200MHz Vertical back/Area Scan (7x13x1): Measurement grid: dx=10mm, dy=10mm

Maximum value of SAR (measured) = 0.202 mW/g

Configuration/802.11a 5200MHz Vertical back/Zoom Scan (6x6x6)/Cube 0: Measurement grid: dx=5mm, dy=5mm, dz=2mm, Reference Value = 3.562 V/m; Power Drift = 0.11 dB

Peak SAR (extrapolated) = 0.382 mW/g

SAR(1 g) = 0.097 mW/g; SAR(10 g) = 0.028 mW/g, Maximum value of SAR (measured) = 0.204 mW/g

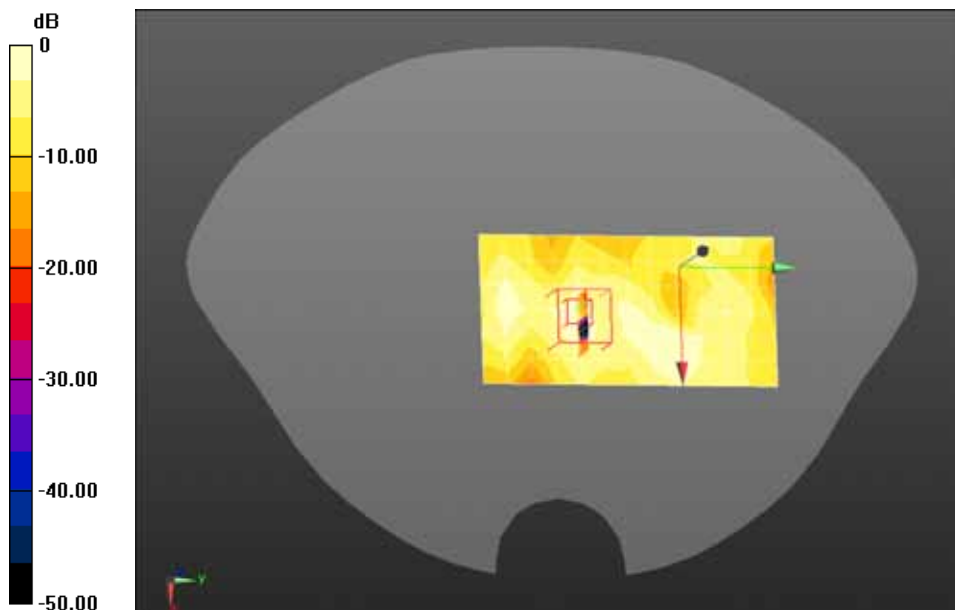

0 dB = 0.204 mW/g = -13.81 dB mW/g

Date/Time: 10-03-2014

Test Laboratory: QuieTek Lab

802.11a 5200MHz Tip-ant 1

DUT: IP-STB; Type: 3500X

Communication System: CW; Communication System Band: 5GHz(5000.0-6000.0MHz); Duty Cycle: 1:1.0; Frequency: 5200 MHz; Medium parameters used: $f = 5200$ MHz; $\sigma = 5.15$ mho/m; $\epsilon_r = 48.94$; $\rho = 1000$ kg/m³ ; Phantom section: Flat Section

Ambient temperature (): 21.5, Liquid temperature (): 21.0

DASY5 Configuration:

- Probe: EX3DV4 - SN3962; ConvF(4.18, 4.18, 4.18); Calibrated: 10/12/2013;
- Sensor-Surface: 2mm (Mechanical Surface Detection)
- Electronics: DAE4 Sn1220; Calibrated: 22/01/2014
- Phantom: SAM1; Type: SAM; Serial: TP1561
- Measurement SW: DASY52, Version 52.8 (1); SEMCAD X Version 14.6.5 (6469)

Configuration/802.11a 5200MHz Tip/Area Scan (7x7x1): Measurement grid: dx=10mm, dy=10mm

Maximum value of SAR (measured) = 0.488 mW/g

Configuration/802.11a 5200MHz Tip/Zoom Scan (6x6x6)/Cube 0: Measurement grid: dx=5mm, dy=5mm, dz=2mm, Reference Value = 2.264 V/m; Power Drift = 0.06 dB

Peak SAR (extrapolated) = 0.971 mW/g

SAR(1 g) = 0.285 mW/g; SAR(10 g) = 0.104 mW/g, Maximum value of SAR (measured) = 0.501 mW/g

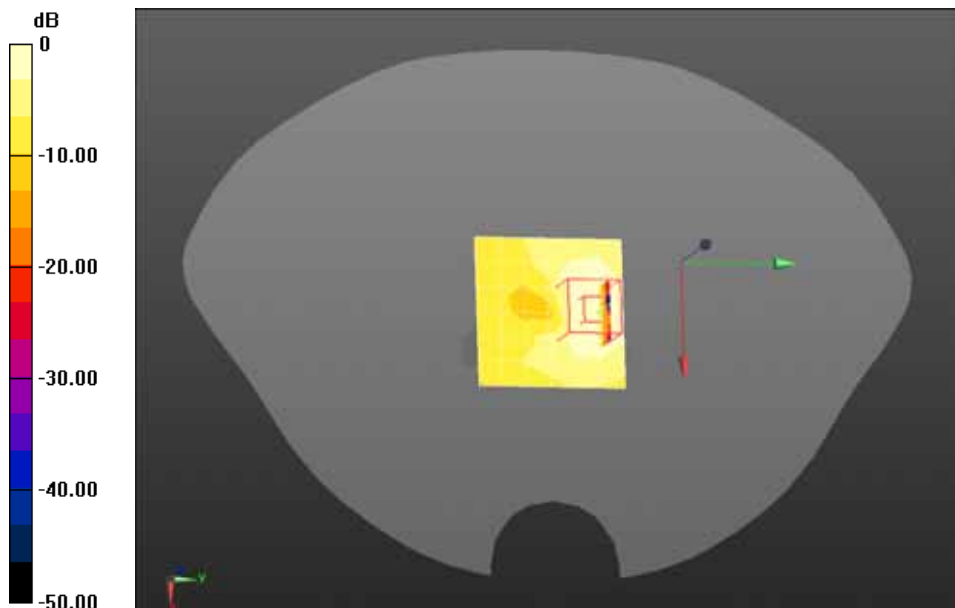

0 dB = 0.501 mW/g = -6.00 dB mW/g

Date/Time: 10-03-2014

Test Laboratory: QuieTek Lab

802.11a 5240MHz Vertical Front-ant 1

DUT: IP-STB; Type: 3500X

Communication System: CW; Communication System Band: 5GHz(5000.0-6000.0MHz); Duty Cycle: 1:1.0;
 Frequency: 5240 MHz; Medium parameters used: $f = 5240 \text{ MHz}$; $\sigma = 5.21 \text{ mho/m}$; $\epsilon_r = 48.84$; $\rho = 1000 \text{ kg/m}^3$; Phantom section: Flat Section

Ambient temperature (): 21.5, Liquid temperature (): 21.0

DASY5 Configuration:

- Probe: EX3DV4 - SN3962; ConvF(4.18, 4.18, 4.18); Calibrated: 10/12/2013;
- Sensor-Surface: 2mm (Mechanical Surface Detection)
- Electronics: DAE4 Sn1220; Calibrated: 22/01/2014
- Phantom: SAM1; Type: SAM; Serial: TP1561
- Measurement SW: DASY52, Version 52.8 (1); SEMCAD X Version 14.6.5 (6469)

Configuration/802.11a 5240MHz Vertical Front/Area Scan (7x13x1): Measurement grid: dx=10mm, dy=10mm

Maximum value of SAR (measured) = 2.15 mW/g

Configuration/802.11a 5240MHz Vertical Front/Zoom Scan (6x6x6)/Cube 0: Measurement grid: dx=5mm, dy=5mm, dz=2mm, Reference Value = 8.765 V/m; Power Drift = 0.03 dB

Peak SAR (extrapolated) = 4.073 mW/g

SAR(1 g) = 1.17 mW/g; SAR(10 g) = 0.409 mW/g, Maximum value of SAR (measured) = 2.21 mW/g

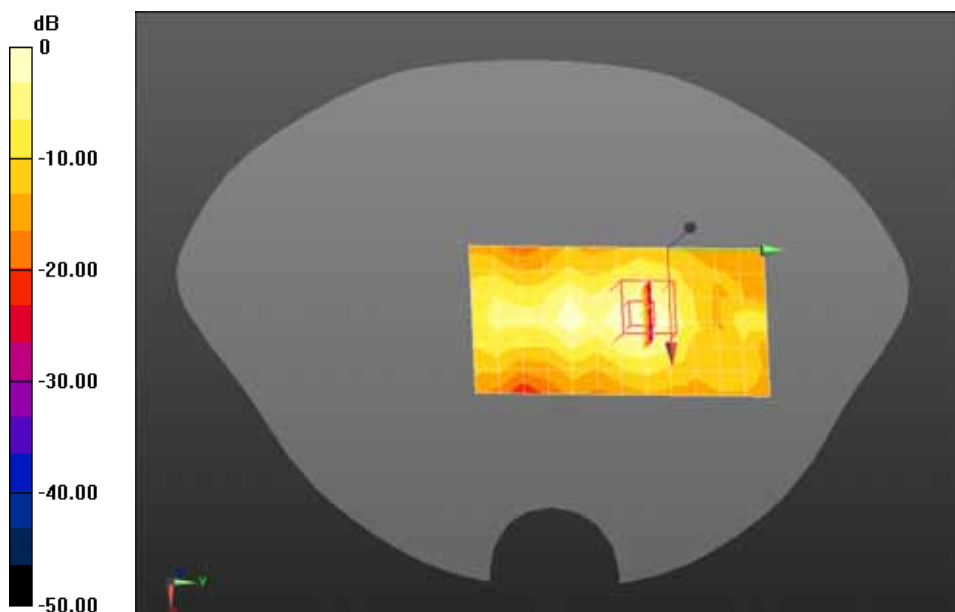

0 dB = 2.21 mW/g = 6.89 dB mW/g

Date/Time: 10-03-2014

*Test Laboratory: QuieTek Lab

802.11a 5240MHz Vertical Front-ant 1

DUT: IP-STB; Type: 3500X

Communication System: CW; Communication System Band: 5GHz(5000.0-6000.0MHz); Duty Cycle: 1:1.0;
 Frequency: 5240 MHz; Medium parameters used: $f = 5240 \text{ MHz}$; $\sigma = 5.21 \text{ mho/m}$; $\epsilon_r = 48.84$; $\rho = 1000 \text{ kg/m}^3$; Phantom section: Flat Section

Ambient temperature (): 21.5, Liquid temperature (): 21.0

DASY5 Configuration:

- Probe: EX3DV4 - SN3962; ConvF(4.18, 4.18, 4.18); Calibrated: 10/12/2013;
- Sensor-Surface: 2mm (Mechanical Surface Detection)
- Electronics: DAE4 Sn1220; Calibrated: 22/01/2014
- Phantom: SAM1; Type: SAM; Serial: TP1561
- Measurement SW: DASY52, Version 52.8 (1); SEMCAD X Version 14.6.5 (6469)

Configuration/802.11a 5240MHz Vertical Front/Area Scan (7x13x1): Measurement grid: dx=10mm, dy=10mm

Maximum value of SAR (measured) = 2.10 mW/g

Configuration/802.11a 5240MHz Vertical Front/Zoom Scan (6x6x6)/Cube 0: Measurement grid: dx=5mm, dy=5mm, dz=2mm, Reference Value = 13.130 V/m; Power Drift = 0.08 dB

Peak SAR (extrapolated) = 4.004 mW/g

SAR(1 g) = 1.16 mW/g; SAR(10 g) = 0.406 mW/g, Maximum value of SAR (measured) = 2.16 mW/g

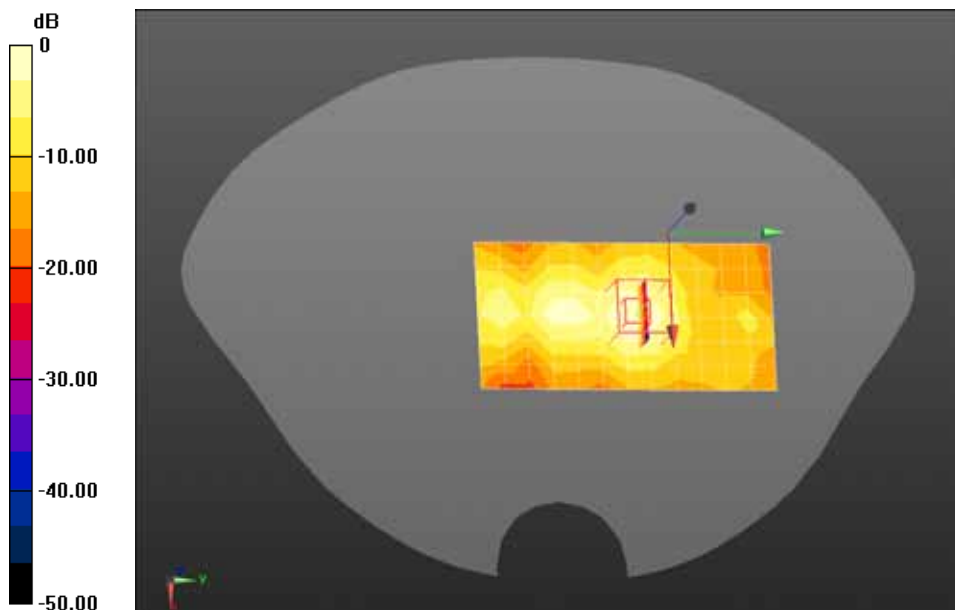

0 dB = 2.16 mW/g = 6.69 dB mW/g

Date/Time: 10-03-2014

Test Laboratory: QuieTek Lab

802.11a 5200MHz Vertical Front-Ant 0

DUT: IP-STB; Type: 3500X

Communication System: CW; Communication System Band: 5GHz(5000.0-6000.0MHz); Duty Cycle: 1:1.0;
 Frequency: 5200 MHz; Medium parameters used: $f = 5200$ MHz; $\sigma = 5.15$ mho/m; $\epsilon_r = 48.94$; $\rho = 1000$ kg/m³ ; Phantom section: Flat Section

Ambient temperature (): 21.5, Liquid temperature (): 21.0

DASY5 Configuration:

- Probe: EX3DV4 - SN3962; ConvF(4.18, 4.18, 4.18); Calibrated: 10/12/2013;
- Sensor-Surface: 2mm (Mechanical Surface Detection)
- Electronics: DAE4 Sn1220; Calibrated: 22/01/2014
- Phantom: SAM1; Type: SAM; Serial: TP1561
- Measurement SW: DASY52, Version 52.8 (1); SEMCAD X Version 14.6.5 (6469)

Configuration/802.11a 5200MHz Vertical Front/Area Scan (7x13x1): Measurement grid: dx=10mm, dy=10mm

Maximum value of SAR (measured) = 0.237 mW/g

Configuration/802.11a 5200MHz Vertical Front/Zoom Scan (6x6x6)/Cube 0: Measurement grid:

dx=5mm, dy=5mm, dz=2mm, Reference Value = 2.380 V/m; Power Drift = 0.09 dB

Peak SAR (extrapolated) = 1.039 mW/g

SAR(1 g) = 0.205 mW/g; SAR(10 g) = 0.049 mW/g Maximum value of SAR (measured) = 0.783 mW/g

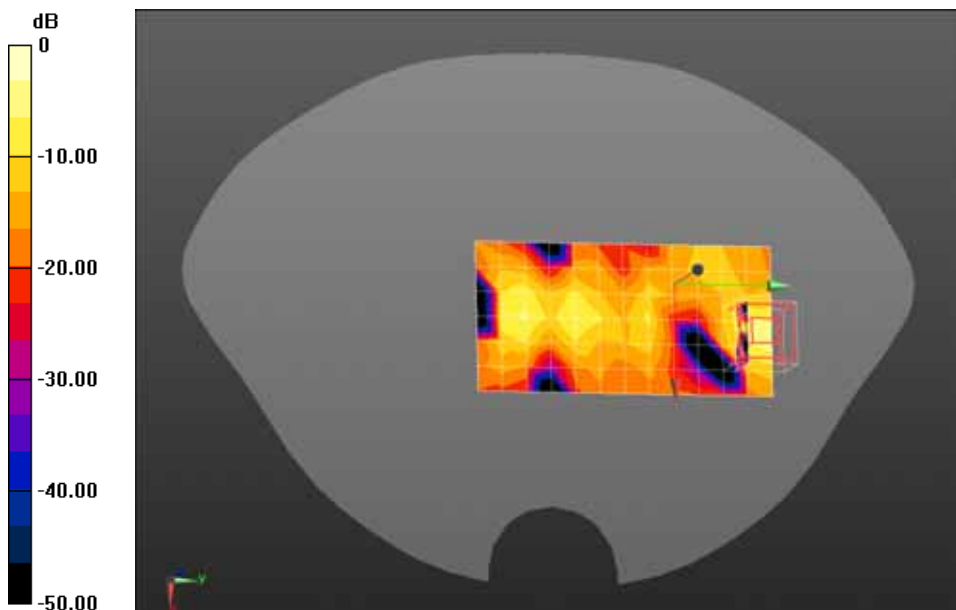

0 dB = 0.783 mW/g = -2.12 dB mW/g

Date/Time: 10-03-2014

Test Laboratory: QuieTek Lab

802.11n(20) 5200MHz Vertical Front-ant (0+1)

DUT: IP-STB; Type: 3500X

Communication System: CW; Communication System Band: 5GHz(5000.0-6000.0MHz); Duty Cycle: 1:1.0;
 Frequency: 5200 MHz; Medium parameters used: $f = 5200$ MHz; $\sigma = 5.15$ mho/m; $\epsilon_r = 48.94$; $\rho = 1000$ kg/m³ ; Phantom section: Flat Section

Ambient temperature (): 21.5, Liquid temperature (): 21.0

DASY5 Configuration:

- Probe: EX3DV4 - SN3962; ConvF(4.18, 4.18, 4.18); Calibrated: 10/12/2013;
- Sensor-Surface: 2mm (Mechanical Surface Detection)
- Electronics: DAE4 Sn1220; Calibrated: 22/01/2014
- Phantom: SAM1; Type: SAM; Serial: TP1561
- Measurement SW: DASY52, Version 52.8 (1); SEMCAD X Version 14.6.5 (6469)

Configuration/802.11n(20) 5200MHz Vertical Front/Area Scan (7x13x1): Measurement grid: dx=10mm, dy=10mm

Maximum value of SAR (measured) = 0.814 mW/g

Configuration/802.11n(20) 5200MHz Vertical Front/Zoom Scan (6x6x6)/Cube 0: Measurement grid: dx=5mm, dy=5mm, dz=2mm, Reference Value = 5.041 V/m; Power Drift = 0.17 dB

Peak SAR (extrapolated) = 1.654 mW/g

SAR(1 g) = 0.487 mW/g; SAR(10 g) = 0.169 mW/g, Maximum value of SAR (measured) = 0.896 mW/g

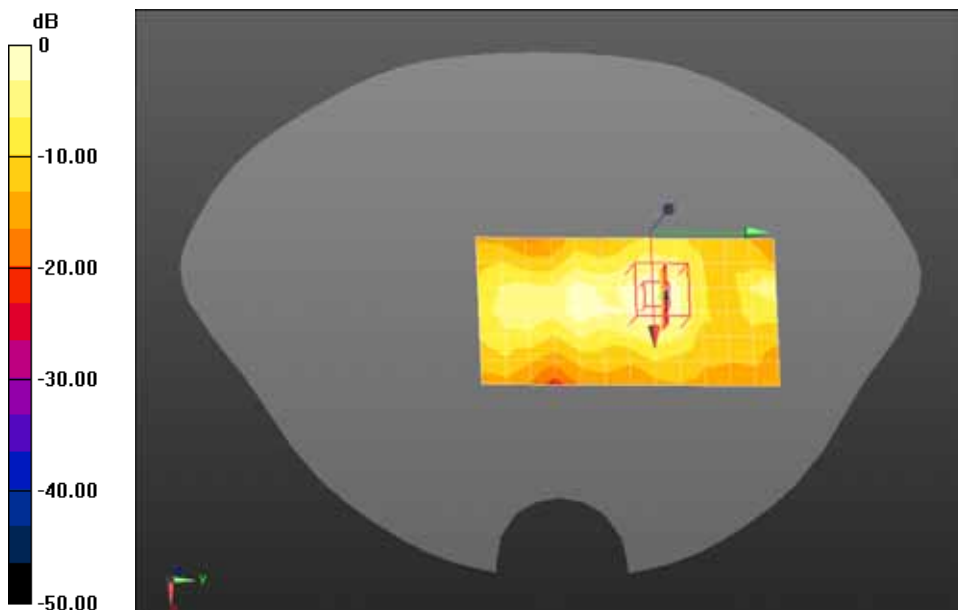

0 dB = 0.896 mW/g = -0.95 dB mW/g

Date/Time: 10-03-2014

Test Laboratory: QuieTek Lab

802.11n(20) 5240MHz Vertical Front-ant (0+1)

DUT: IP-STB; Type: 3500X

Communication System: CW; Communication System Band: 5GHz(5000.0-6000.0MHz); Duty Cycle: 1:1.0;
 Frequency: 5240 MHz; Medium parameters used: $f = 5240$ MHz; $\sigma = 5.21$ mho/m; $\epsilon_r = 48.84$; $\rho = 1000$ kg/m³ ; Phantom section: Flat Section

Ambient temperature (): 21.5, Liquid temperature (): 21.0

DASY5 Configuration:

- Probe: EX3DV4 - SN3962; ConvF(4.18, 4.18, 4.18); Calibrated: 10/12/2013;
- Sensor-Surface: 2mm (Mechanical Surface Detection)
- Electronics: DAE4 Sn1220; Calibrated: 22/01/2014
- Phantom: SAM1; Type: SAM; Serial: TP1561
- Measurement SW: DASY52, Version 52.8 (1); SEMCAD X Version 14.6.5 (6469)

Configuration/802.11n(20) 5240MHz Vertical Front/Area Scan (7x13x1): Measurement grid: dx=10mm, dy=10mm

Maximum value of SAR (measured) = 0.691 mW/g

Configuration/802.11n(20) 5240MHz Vertical Front/Zoom Scan (6x6x6)/Cube 0: Measurement grid: dx=5mm, dy=5mm, dz=2mm, Reference Value = 4.949 V/m; Power Drift = 0.10 dB

Peak SAR (extrapolated) = 1.409 mW/g

SAR(1 g) = 0.406 mW/g; SAR(10 g) = 0.143 mW/g, Maximum value of SAR (measured) = 0.738 mW/g

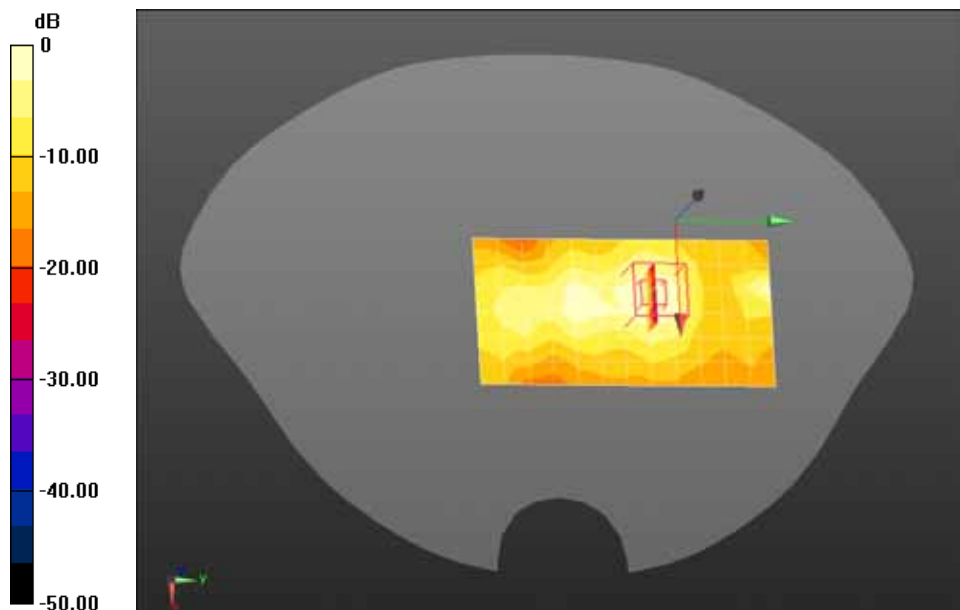

0 dB = 0.738 mW/g = -2.64 dB mW/g

Date/Time: 10-03-2014

Test Laboratory: QuieTek Lab

802.11n(40) 5190MHz Vertical Front-ant (0+1)

DUT: IP-STB; Type: 3500X

Communication System: CW; Communication System Band: 5GHz(5000.0-6000.0MHz); Duty Cycle: 1:1.0; Frequency: 5190 MHz; Medium parameters used: $f = 5190$ MHz; $\sigma = 5.13$ mho/m; $\epsilon_r = 48.98$; $\rho = 1000$ kg/m³ ; Phantom section: Flat Section

Ambient temperature (): 21.5, Liquid temperature (): 21.0

DASY5 Configuration:

- Probe: EX3DV4 - SN3962; ConvF(4.18, 4.18, 4.18); Calibrated: 10/12/2013;
- Sensor-Surface: 2mm (Mechanical Surface Detection)
- Electronics: DAE4 Sn1220; Calibrated: 22/01/2014
- Phantom: SAM1; Type: SAM; Serial: TP1561
- Measurement SW: DASY52, Version 52.8 (1); SEMCAD X Version 14.6.5 (6469)

Configuration/802.11n(40) 5190MHz Vertical Front/Area Scan (7x13x1): Measurement grid: dx=10mm, dy=10mm

Maximum value of SAR (measured) = 0.618 mW/g

Configuration/802.11n(40) 5190MHz Vertical Front/Zoom Scan (6x6x6)/Cube 0: Measurement grid: dx=5mm, dy=5mm, dz=2mm, Reference Value = 4.219 V/m; Power Drift = 0.14 dB

Peak SAR (extrapolated) = 1.249 mW/g

SAR(1 g) = 0.364 mW/g; SAR(10 g) = 0.127 mW/g, Maximum value of SAR (measured) = 0.677 mW/g

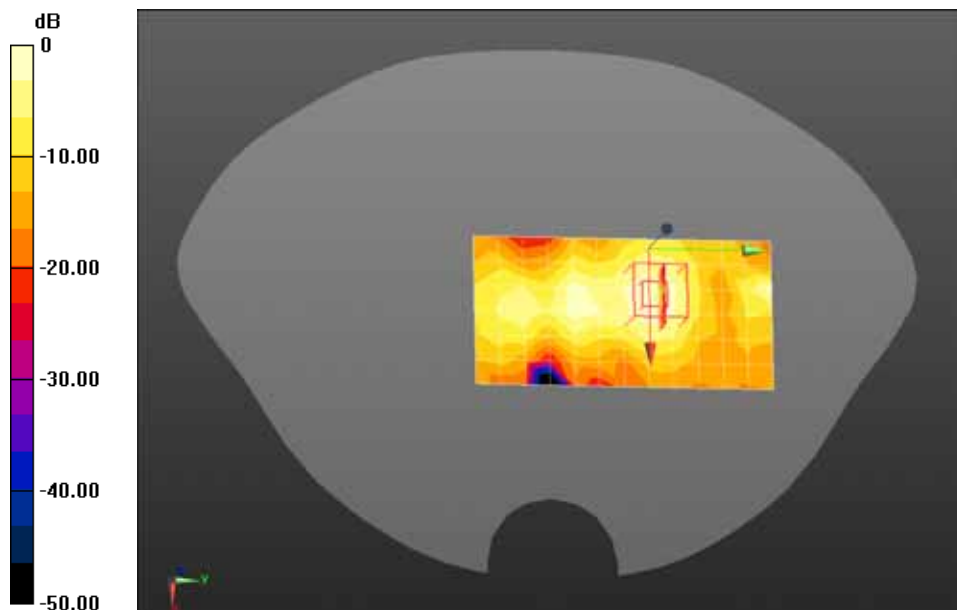

0 dB = 0.677 mW/g = -3.39 dB mW/g

Date/Time: 10-03-2014

Test Laboratory: QuieTek Lab

802.11a 5785MHz Horizontal up-ant 1

DUT: IP-STB; Type: 3500X

Communication System: CW; Communication System Band: 5GHz(5000.0-6000.0MHz); Duty Cycle: 1:1.0;
 Frequency: 5785 MHz; Medium parameters used: $f = 5785$ MHz; $\sigma = 6.01$ mho/m; $\epsilon_r = 47.34$; $\rho = 1000$ kg/m³ ; Phantom section: Flat Section

Ambient temperature (): 21.5, Liquid temperature (): 21.0

DASY5 Configuration:

- Probe: EX3DV4 - SN3962; ConvF(3.96, 3.96, 3.96); Calibrated: 10/12/2013;
- Sensor-Surface: 2mm (Mechanical Surface Detection)
- Electronics: DAE4 Sn1220; Calibrated: 22/01/2014
- Phantom: SAM1; Type: SAM; Serial: TP1561
- Measurement SW: DASY52, Version 52.8 (1); SEMCAD X Version 14.6.5 (6469)

Configuration/802.11a 5785MHz Horizontal up/Area Scan (7x13x1): Measurement grid: dx=10mm, dy=10mm

Maximum value of SAR (measured) = 1.02 mW/g

Configuration/802.11a 5785MHz Horizontal up/Zoom Scan (6x6x6)/Cube 0: Measurement grid:

dx=5mm, dy=5mm, dz=2mm, Reference Value = 4.732 V/m; Power Drift = 0.06 dB

Peak SAR (extrapolated) = 3.033 mW/g

SAR(1 g) = 0.666 mW/g; SAR(10 g) = 0.221 mW/g Maximum value of SAR (measured) = 1.33 mW/g

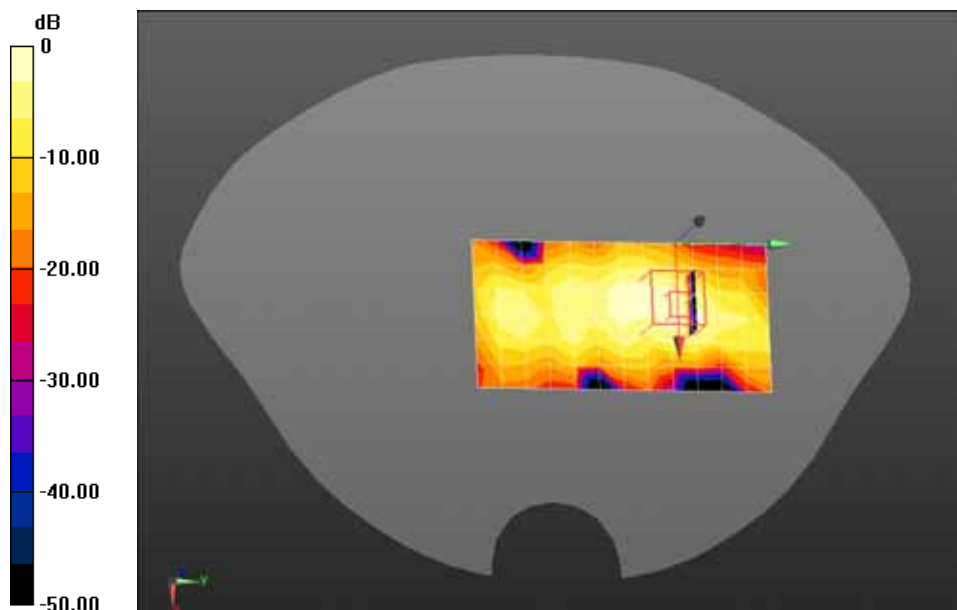

0 dB = 1.33 mW/g = 2.48 dB mW/g

Date/Time: 10-03-2014

Test Laboratory: QuieTek Lab

802.11a 5785MHz Horizontal down-ant 1

DUT: IP-STB; Type: 3500X

Communication System: CW; Communication System Band: 5GHz(5000.0-6000.0MHz); Duty Cycle: 1:1.0; Frequency: 5785 MHz; Medium parameters used: $f = 5785 \text{ MHz}$; $\sigma = 6.01 \text{ mho/m}$; $\epsilon_r = 47.34$; $\rho = 1000 \text{ kg/m}^3$; Phantom section: Flat Section

Ambient temperature (): 21.5, Liquid temperature (): 21.0

DASY5 Configuration:

- Probe: EX3DV4 - SN3962; ConvF(3.96, 3.96, 3.96); Calibrated: 10/12/2013;
- Sensor-Surface: 2mm (Mechanical Surface Detection)
- Electronics: DAE4 Sn1220; Calibrated: 22/01/2014
- Phantom: SAM1; Type: SAM; Serial: TP1561
- Measurement SW: DASY52, Version 52.8 (1); SEMCAD X Version 14.6.5 (6469)

Configuration/802.11a 5785MHz Horizontal down/Area Scan (7x13x1): Measurement grid: dx=10mm, dy=10mm

Maximum value of SAR (measured) = 1.14 mW/g

Configuration/802.11a 5785MHz Horizontal down/Zoom Scan (6x6x6)/Cube 0: Measurement grid: dx=5mm, dy=5mm, dz=2mm, Reference Value = 7.028 V/m; Power Drift = 0.13 dB

Peak SAR (extrapolated) = 2.586 mW/g

SAR(1 g) = 0.614 mW/g; SAR(10 g) = 0.233 mW/g, Maximum value of SAR (measured) = 1.23 mW/g

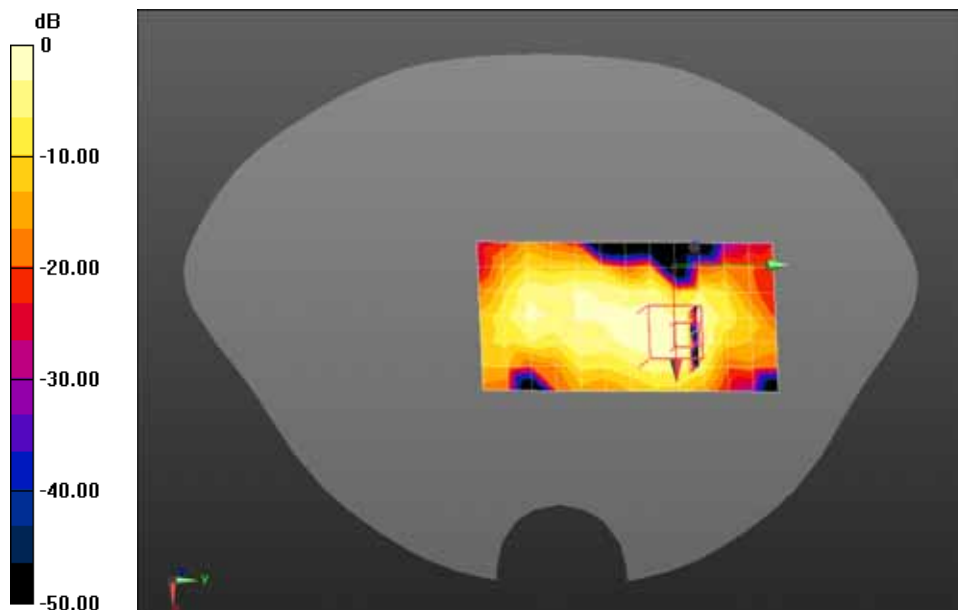

0 dB = 1.23 mW/g = 1.80 dB mW/g

Date/Time: 10-03-2014

Test Laboratory: QuieTek Lab

802.11a 5785MHz Vertical Front-ant 1

DUT: IP-STB; Type: 3500X

Communication System: CW; Communication System Band: 5GHz(5000.0-6000.0MHz); Duty Cycle: 1:1.0; Frequency: 5785 MHz; Medium parameters used: $f = 5785$ MHz; $\sigma = 6.01$ mho/m; $\epsilon_r = 47.34$; $\rho = 1000$ kg/m³ ; Phantom section: Flat Section

Ambient temperature (): 21.5, Liquid temperature (): 21.0

DASY5 Configuration:

- Probe: EX3DV4 - SN3962; ConvF(3.96, 3.96, 3.96); Calibrated: 10/12/2013;
- Sensor-Surface: 2mm (Mechanical Surface Detection)
- Electronics: DAE4 Sn1220; Calibrated: 22/01/2014
- Phantom: SAM1; Type: SAM; Serial: TP1561
- Measurement SW: DASY52, Version 52.8 (1); SEMCAD X Version 14.6.5 (6469)

Configuration/802.11a 5785MHz Vertical Front/Area Scan (7x13x1): Measurement grid: dx=10mm, dy=10mm

Maximum value of SAR (measured) = 1.65 mW/g

Configuration/802.11a 5785MHz Vertical Front/Zoom Scan (6x6x6)/Cube 0: Measurement grid: dx=5mm, dy=5mm, dz=2mm, Reference Value = 11.341 V/m; Power Drift = 0.05 dB

Peak SAR (extrapolated) = 3.772 mW/g

SAR(1 g) = 0.874 mW/g; SAR(10 g) = 0.234 mW/g, Maximum value of SAR (measured) = 1.83 mW/g

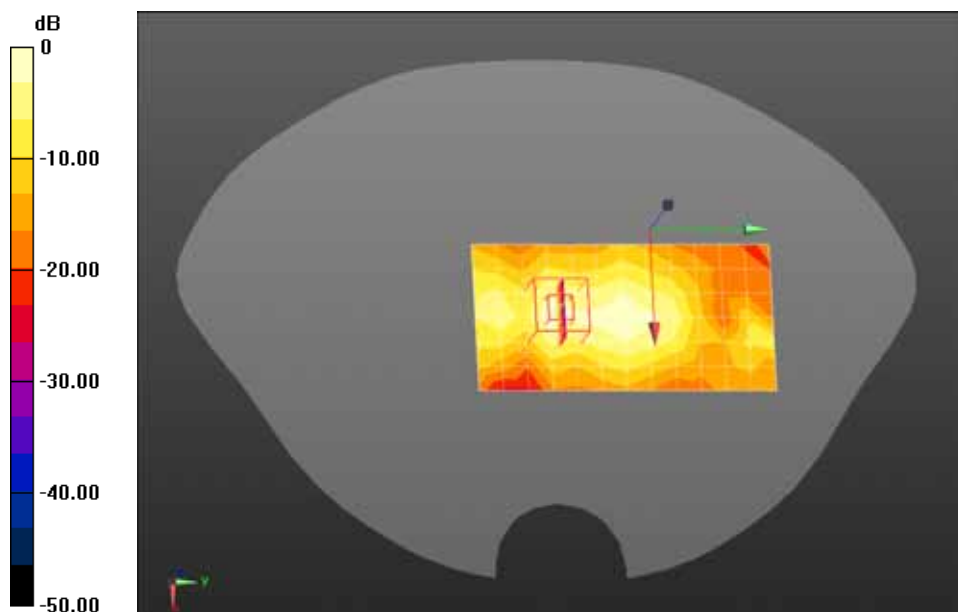

0 dB = 1.83 mW/g = 5.25 dB mW/g

Date/Time: 10-03-2014

*Test Laboratory: QuieTek Lab

802.11a 5785MHz Vertical Front-ant 1

DUT: IP-STB; Type: 3500X

Communication System: CW; Communication System Band: 5GHz(5000.0-6000.0MHz); Duty Cycle: 1:1.0; Frequency: 5785 MHz; Medium parameters used: $f = 5785 \text{ MHz}$; $\sigma = 6.01 \text{ mho/m}$; $\epsilon_r = 47.34$; $\rho = 1000 \text{ kg/m}^3$; Phantom section: Flat Section

Ambient temperature (): 21.5, Liquid temperature (): 21.0

DASY5 Configuration:

- Probe: EX3DV4 - SN3962; ConvF(3.96, 3.96, 3.96); Calibrated: 10/12/2013;
- Sensor-Surface: 2mm (Mechanical Surface Detection)
- Electronics: DAE4 Sn1220; Calibrated: 22/01/2014
- Phantom: SAM1; Type: SAM; Serial: TP1561
- Measurement SW: DASY52, Version 52.8 (1); SEMCAD X Version 14.6.5 (6469)

Configuration/802.11a 5785MHz Vertical Front/Area Scan (7x13x1): Measurement grid: dx=10mm, dy=10mm

Maximum value of SAR (measured) = 2.25 mW/g

Configuration/802.11a 5785MHz Vertical Front/Zoom Scan (6x6x6)/Cube 0: Measurement grid: dx=5mm, dy=5mm, dz=2mm, Reference Value = 6.549 V/m; Power Drift = 0.04 dB

Peak SAR (extrapolated) = 5.240 mW/g

SAR(1 g) = 1.2 mW/g; SAR(10 g) = 0.308 mW/g, Maximum value of SAR (measured) = 2.61 mW/g

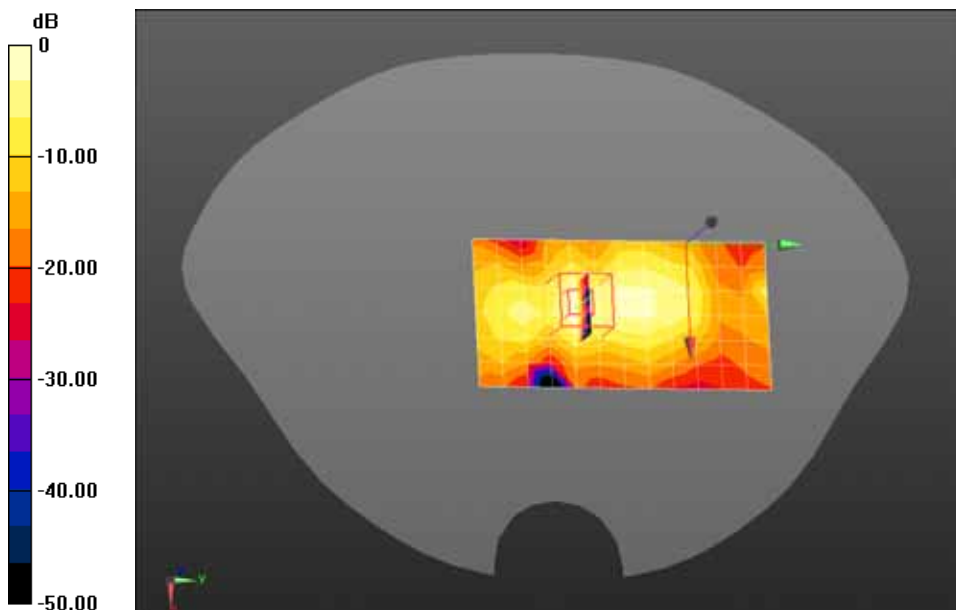

0 dB = 2.61 mW/g = 8.33 dB mW/g

Z-Axis Plot

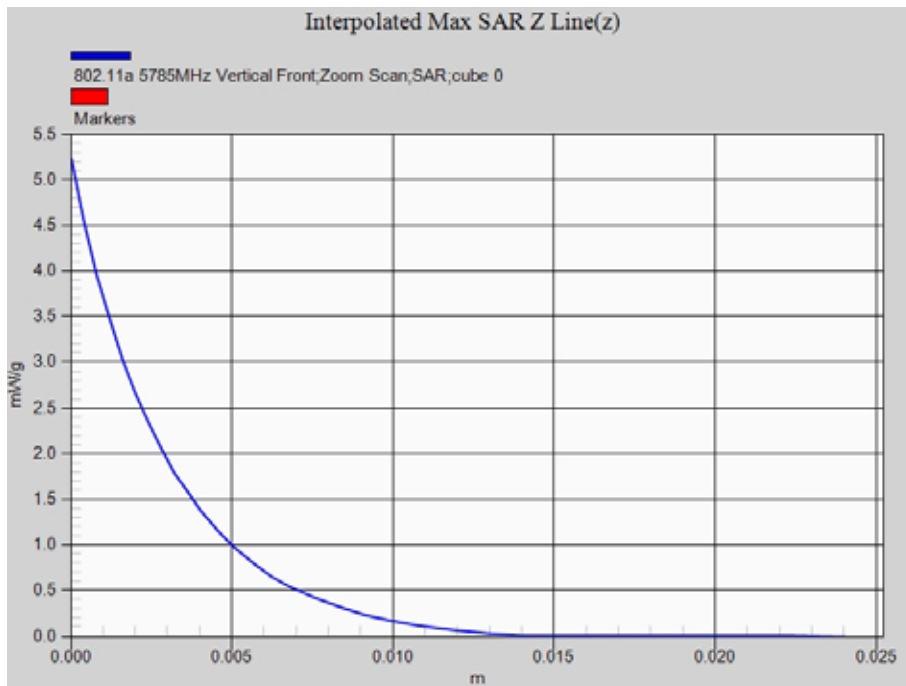

Date/Time: 10-03-2014

Test Laboratory: QuieTek Lab

802.11a 5785MHz Vertical back-ant 1

DUT: IP-STB; Type: 3500X

Communication System: CW; Communication System Band: 5GHz(5000.0-6000.0MHz); Duty Cycle: 1:1.0;
 Frequency: 5785 MHz; Medium parameters used: $f = 5785 \text{ MHz}$; $\sigma = 6.01 \text{ mho/m}$; $\epsilon_r = 47.34$; $\rho = 1000 \text{ kg/m}^3$; Phantom section: Flat Section

Ambient temperature (): 21.5, Liquid temperature (): 21.0

DASY5 Configuration:

- Probe: EX3DV4 - SN3962; ConvF(3.96, 3.96, 3.96); Calibrated: 10/12/2013;
- Sensor-Surface: 2mm (Mechanical Surface Detection)
- Electronics: DAE4 Sn1220; Calibrated: 22/01/2014
- Phantom: SAM1; Type: SAM; Serial: TP1561
- Measurement SW: DASY52, Version 52.8 (1); SEMCAD X Version 14.6.5 (6469)

Configuration/802.11a 5785MHz Vertical back/Area Scan (7x13x1): Measurement grid: dx=10mm, dy=10mm

Maximum value of SAR (measured) = 0.253 mW/g

Configuration/802.11a 5785MHz Vertical back/Zoom Scan (6x6x6)/Cube 0: Measurement grid: dx=5mm, dy=5mm, dz=2mm, Reference Value = 2.879 V/m; Power Drift = -0.12 dB

Peak SAR (extrapolated) = 0.547 mW/g

SAR(1 g) = 0.118 mW/g; SAR(10 g) = 0.031 mW/g, Maximum value of SAR (measured) = 0.270 mW/g

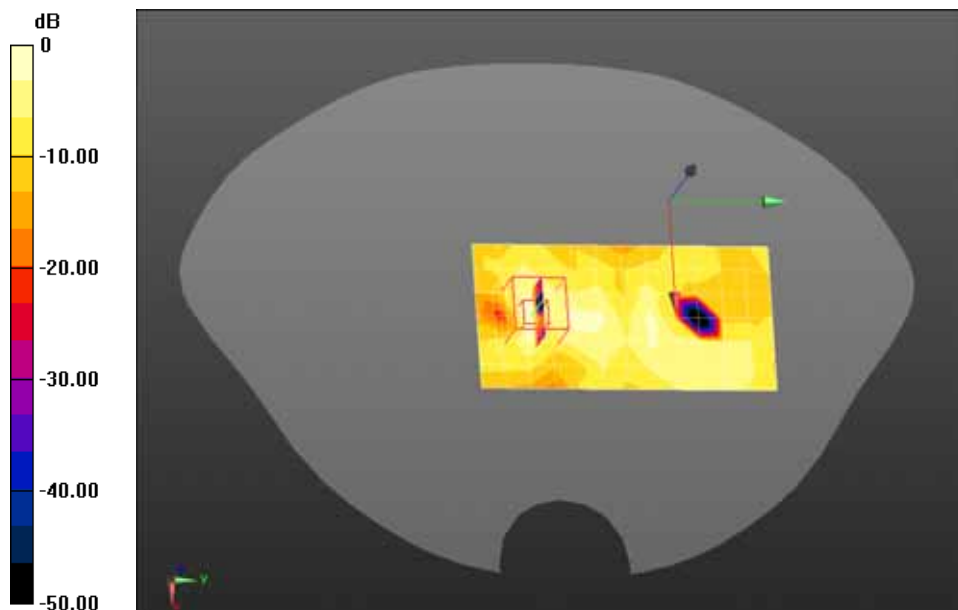

0 dB = 0.270 mW/g = -11.37 dB mW/g

Date/Time: 10-03-2014

Test Laboratory: QuieTek Lab

802.11a 5785MHz Tip-ant 1

DUT: IP-STB; Type: 3500X

Communication System: CW; Communication System Band: 5GHz(5000.0-6000.0MHz); Duty Cycle: 1:1.0; Frequency: 5785 MHz; Medium parameters used: $f = 5785 \text{ MHz}$; $\sigma = 6.01 \text{ mho/m}$; $\epsilon_r = 47.34$; $\rho = 1000 \text{ kg/m}^3$; Phantom section: Flat Section

Ambient temperature (): 21.5, Liquid temperature (): 21.0

DASY5 Configuration:

- Probe: EX3DV4 - SN3962; ConvF(3.96, 3.96, 3.96); Calibrated: 10/12/2013;
- Sensor-Surface: 2mm (Mechanical Surface Detection)
- Electronics: DAE4 Sn1220; Calibrated: 22/01/2014
- Phantom: SAM1; Type: SAM; Serial: TP1561
- Measurement SW: DASY52, Version 52.8 (1); SEMCAD X Version 14.6.5 (6469)

Configuration/802.11a 5785MHz Tip/Area Scan (7x7x1): Measurement grid: dx=10mm, dy=10mm

Maximum value of SAR (measured) = 0.720 mW/g

Configuration/802.11a 5785MHz Tip/Zoom Scan (6x6x6)/Cube 0: Measurement grid: dx=5mm, dy=5mm, dz=2mm, Reference Value = 2.431 V/m; Power Drift = -0.14 dB

Peak SAR (extrapolated) = 1.706 mW/g

SAR(1 g) = 0.447 mW/g; SAR(10 g) = 0.154 mW/g, Maximum value of SAR (measured) = 0.825 mW/g

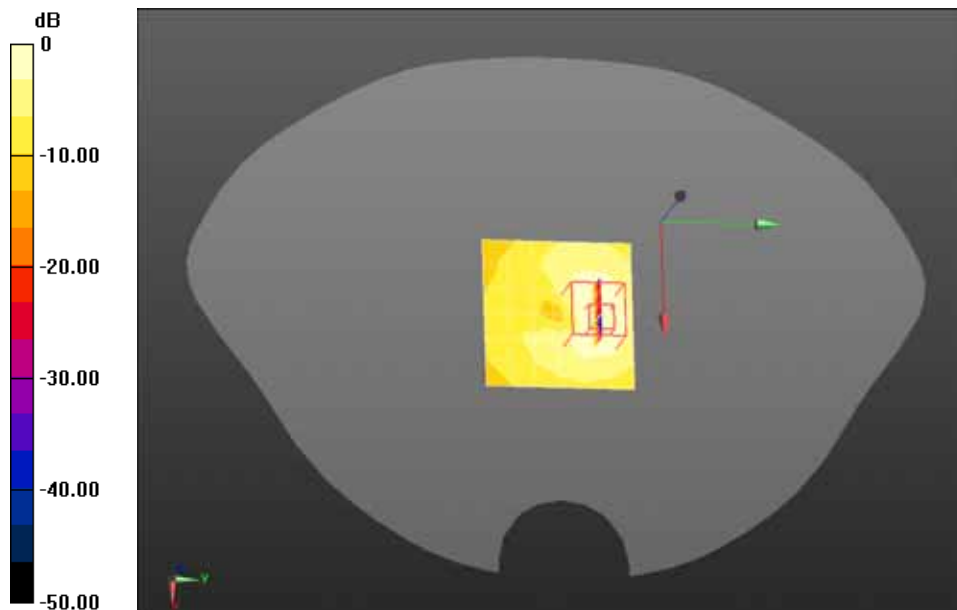

0 dB = 0.825 mW/g = -1.67 dB mW/g

Date/Time: 10-03-2014

Test Laboratory: QuieTek Lab

802.11a 5745MHz Vertical Front-ant 1

DUT: IP-STB; Type: 3500X

Communication System: CW; Communication System Band: 5GHz(5000.0-6000.0MHz); Duty Cycle: 1:1.0;
 Frequency: 5745 MHz; Medium parameters used: $f = 5745$ MHz; $\sigma = 5.95$ mho/m; $\epsilon_r = 47.44$; $\rho = 1000$ kg/m³ ; Phantom section: Flat Section

Ambient temperature (): 21.5, Liquid temperature (): 21.0

DASY5 Configuration:

- Probe: EX3DV4 - SN3962; ConvF(3.96, 3.96, 3.96); Calibrated: 10/12/2013;
- Sensor-Surface: 2mm (Mechanical Surface Detection)
- Electronics: DAE4 Sn1220; Calibrated: 22/01/2014
- Phantom: SAM1; Type: SAM; Serial: TP1561
- Measurement SW: DASY52, Version 52.8 (1); SEMCAD X Version 14.6.5 (6469)

Configuration/802.11a 5745MHz Vertical Front/Area Scan (7x13x1): Measurement grid: dx=10mm, dy=10mm

Maximum value of SAR (measured) = 1.26 mW/g

Configuration/802.11a 5745MHz Vertical Front/Zoom Scan (6x6x6)/Cube 0: Measurement grid: dx=5mm, dy=5mm, dz=2mm, Reference Value = 5.420 V/m; Power Drift = 0.01 dB

Peak SAR (extrapolated) = 2.858 mW/g

SAR(1 g) = 0.674 mW/g; SAR(10 g) = 0.185 mW/g, Maximum value of SAR (measured) = 1.40 mW/g

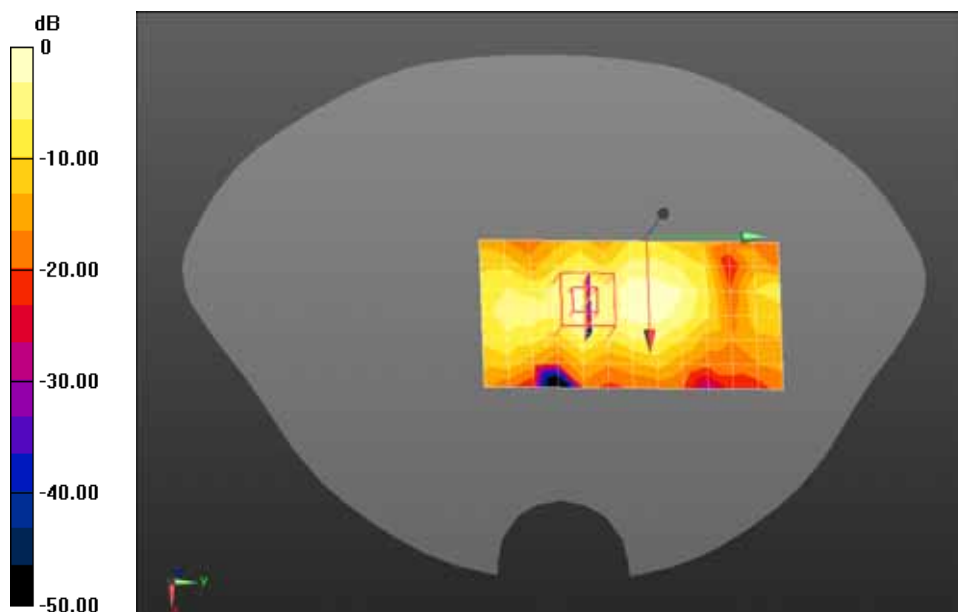

0 dB = 1.40 mW/g = 2.92 dB mW/g

Date/Time: 10-03-2014

Test Laboratory: QuieTek Lab

802.11a 5825MHz Vertical Front-ant 1

DUT: IP-STB; Type: 3500X

Communication System: CW; Communication System Band: 5GHz(5000.0-6000.0MHz); Duty Cycle: 1:1.0;
 Frequency: 5825 MHz; Medium parameters used: $f = 5825$ MHz; $\sigma = 6.08$ mho/m; $\epsilon_r = 47.23$; $\rho = 1000$ kg/m³ ; Phantom section: Flat Section

Ambient temperature (): 21.5, Liquid temperature (): 21.0

DASY5 Configuration:

- Probe: EX3DV4 - SN3962; ConvF(3.96, 3.96, 3.96); Calibrated: 10/12/2013;
- Sensor-Surface: 2mm (Mechanical Surface Detection)
- Electronics: DAE4 Sn1220; Calibrated: 22/01/2014
- Phantom: SAM1; Type: SAM; Serial: TP1561
- Measurement SW: DASY52, Version 52.8 (1); SEMCAD X Version 14.6.5 (6469)

Configuration/802.11a 5825MHz Vertical Front/Area Scan (7x13x1): Measurement grid: dx=10mm, dy=10mm

Maximum value of SAR (measured) = 1.57 mW/g

Configuration/802.11a 5825MHz Vertical Front/Zoom Scan (6x6x6)/Cube 0: Measurement grid: dx=5mm, dy=5mm, dz=2mm, Reference Value = 6.689 V/m; Power Drift = 0.09 dB

Peak SAR (extrapolated) = 3.628 mW/g

SAR(1 g) = 0.849 mW/g; SAR(10 g) = 0.234 mW/g, Maximum value of SAR (measured) = 1.77 mW/g

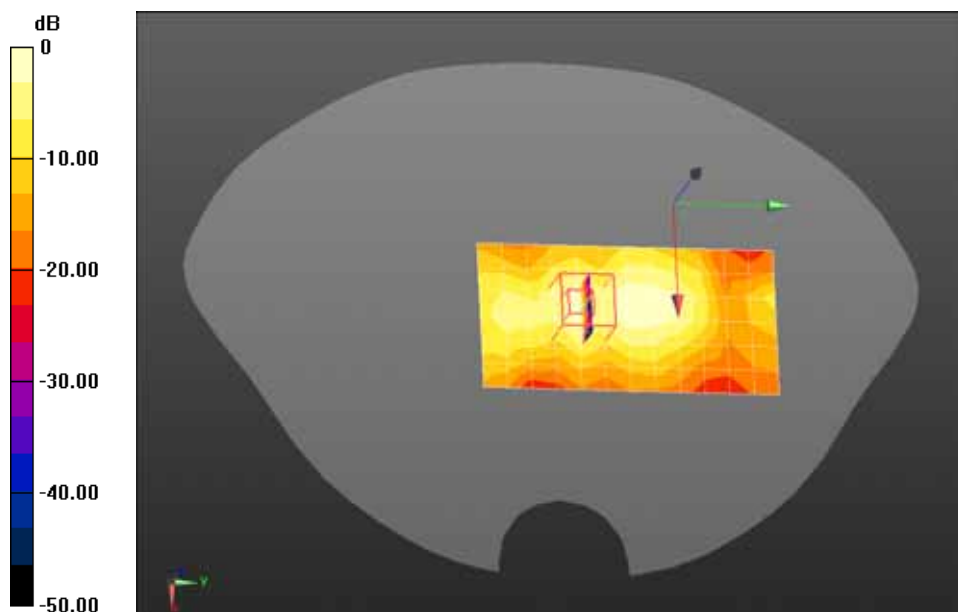

0 dB = 1.77 mW/g = 4.96 dB mW/g

Date/Time: 10-03-2014

Test Laboratory: QuieTek Lab

802.11a 5785MHz Vertical Front-Ant 0

DUT: IP-STB; Type: 3500X

Communication System: CW; Communication System Band: 5GHz(5000.0-6000.0MHz); Duty Cycle: 1:1.0; Frequency: 5785 MHz; Medium parameters used: $f = 5785$ MHz; $\sigma = 6.01$ mho/m; $\epsilon_r = 47.34$; $\rho = 1000$ kg/m³ ; Phantom section: Flat Section

Ambient temperature (): 21.5, Liquid temperature (): 21.0

DASY5 Configuration:

- Probe: EX3DV4 - SN3962; ConvF(3.96, 3.96, 3.96); Calibrated: 10/12/2013;
- Sensor-Surface: 2mm (Mechanical Surface Detection)
- Electronics: DAE4 Sn1220; Calibrated: 22/01/2014
- Phantom: SAM1; Type: SAM; Serial: TP1561
- Measurement SW: DASY52, Version 52.8 (1); SEMCAD X Version 14.6.5 (6469)

Configuration/802.11a 5785MHz Vertical Front/Area Scan (7x13x1): Measurement grid: dx=10mm, dy=10mm

Maximum value of SAR (measured) = 1.46 mW/g

Configuration/802.11a 5785MHz Vertical Front/Zoom Scan (6x6x6)/Cube 0: Measurement grid: dx=5mm, dy=5mm, dz=2mm, Reference Value = 6.474 V/m; Power Drift = 0.12 dB

Peak SAR (extrapolated) = 3.237 mW/g

SAR(1 g) = 0.776 mW/g; SAR(10 g) = 0.215 mW/g, Maximum value of SAR (measured) = 1.62 mW/g

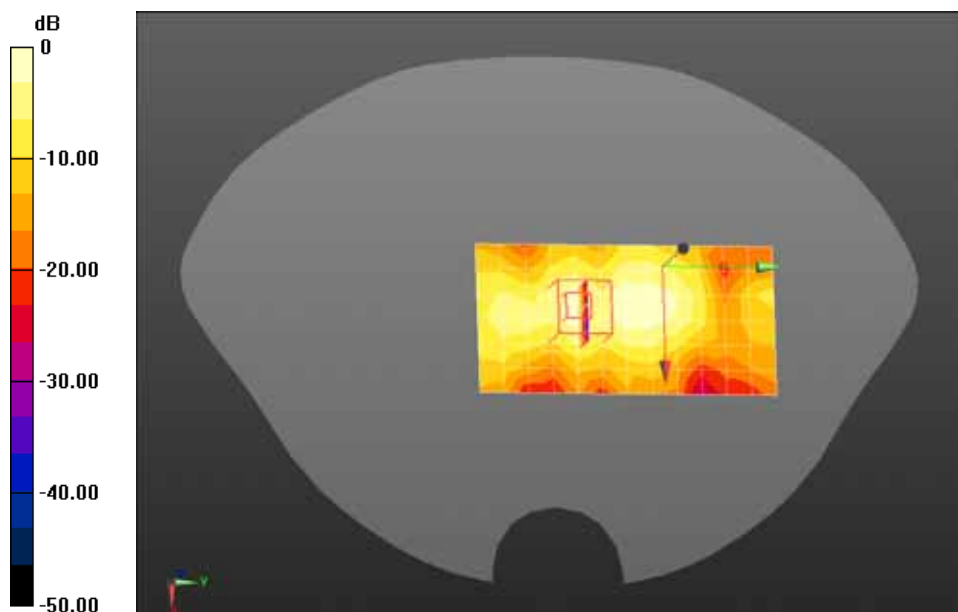

0 dB = 1.62 mW/g = 4.19 dB mW/g

Date/Time: 10-03-2014

Test Laboratory: QuieTek Lab

802.11n(20) 5745MHz Vertical Front-ant (0+1)

DUT: IP-STB; Type: 3500X

Communication System: CW; Communication System Band: 5GHz(5000.0-6000.0MHz); Duty Cycle: 1:1.0;
 Frequency: 5745 MHz; Medium parameters used: $f = 5745 \text{ MHz}$; $\sigma = 5.95 \text{ mho/m}$; $\epsilon_r = 47.44$; $\rho = 1000 \text{ kg/m}^3$; Phantom section: Flat Section

Ambient temperature (): 21.5, Liquid temperature (): 21.0

DASY5 Configuration:

- Probe: EX3DV4 - SN3962; ConvF(3.96, 3.96, 3.96); Calibrated: 10/12/2013;
- Sensor-Surface: 2mm (Mechanical Surface Detection)
- Electronics: DAE4 Sn1220; Calibrated: 22/01/2014
- Phantom: SAM1; Type: SAM; Serial: TP1561
- Measurement SW: DASY52, Version 52.8 (1); SEMCAD X Version 14.6.5 (6469)

Configuration/802.11n(20) 5745MHz Vertical Front/Area Scan (7x13x1): Measurement grid: dx=10mm, dy=10mm

Maximum value of SAR (measured) = 0.645 mW/g

Configuration/802.11n(20) 5745MHz Vertical Front/Zoom Scan (6x6x6)/Cube 0: Measurement grid: dx=5mm, dy=5mm, dz=2mm, Reference Value = 3.648 V/m; Power Drift = 0.18 dB

Peak SAR (extrapolated) = 3.365 mW/g

SAR(1 g) = 0.308 mW/g; SAR(10 g) = 0.085 mW/g, Maximum value of SAR (measured) = 0.684 mW/g

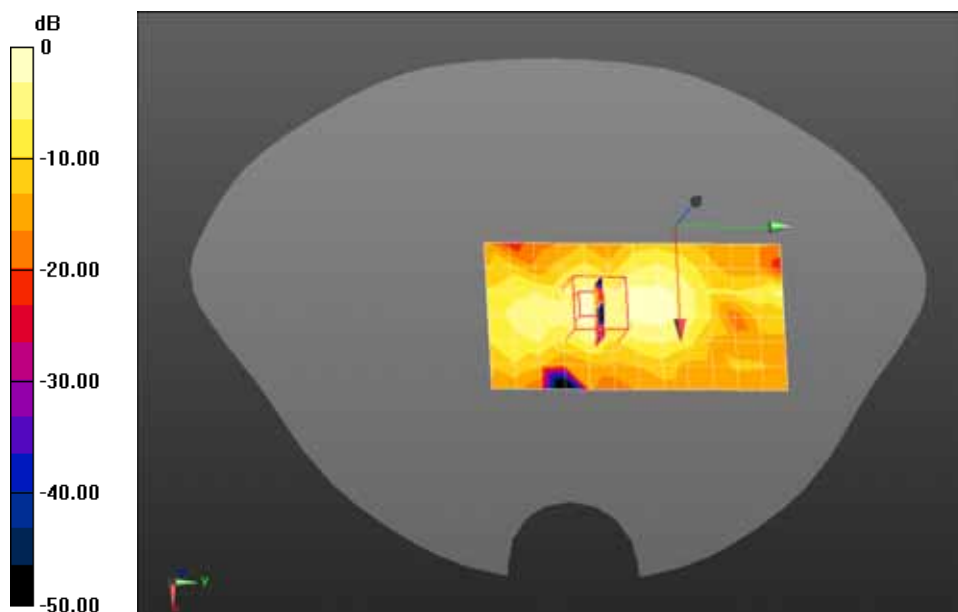

0 dB = 0.684 mW/g = -3.30 dB mW/g

Date/Time: 10-03-2014

Test Laboratory: QuieTek Lab

802.11n(20) 5785MHz Vertical Front-ant (0+1)

DUT: IP-STB; Type: 3500X

Communication System: CW; Communication System Band: 5GHz(5000.0-6000.0MHz); Duty Cycle: 1:1.0;
 Frequency: 5785 MHz; Medium parameters used: $f = 5785 \text{ MHz}$; $\sigma = 6.01 \text{ mho/m}$; $\epsilon_r = 47.34$; $\rho = 1000 \text{ kg/m}^3$; Phantom section: Flat Section

Ambient temperature (): 21.5, Liquid temperature (): 21.0

DASY5 Configuration:

- Probe: EX3DV4 - SN3962; ConvF(3.96, 3.96, 3.96); Calibrated: 10/12/2013;
- Sensor-Surface: 2mm (Mechanical Surface Detection)
- Electronics: DAE4 Sn1220; Calibrated: 22/01/2014
- Phantom: SAM1; Type: SAM; Serial: TP1561
- Measurement SW: DASY52, Version 52.8 (1); SEMCAD X Version 14.6.5 (6469)

Configuration/802.11n(20) 5785MHz Vertical Front/Area Scan (7x13x1): Measurement grid: $dx=10\text{mm}$, $dy=10\text{mm}$

Maximum value of SAR (measured) = 0.801 mW/g

Configuration/802.11n(20) 5785MHz Vertical Front/Zoom Scan (6x6x6)/Cube 0: Measurement grid: $dx=5\text{mm}$, $dy=5\text{mm}$, $dz=2\text{mm}$, Reference Value = 4.725 V/m; Power Drift = 0.05 dB

Peak SAR (extrapolated) = 1.650 mW/g

SAR(1 g) = 0.409 mW/g; SAR(10 g) = 0.111 mW/g, Maximum value of SAR (measured) = 0.906 mW/g

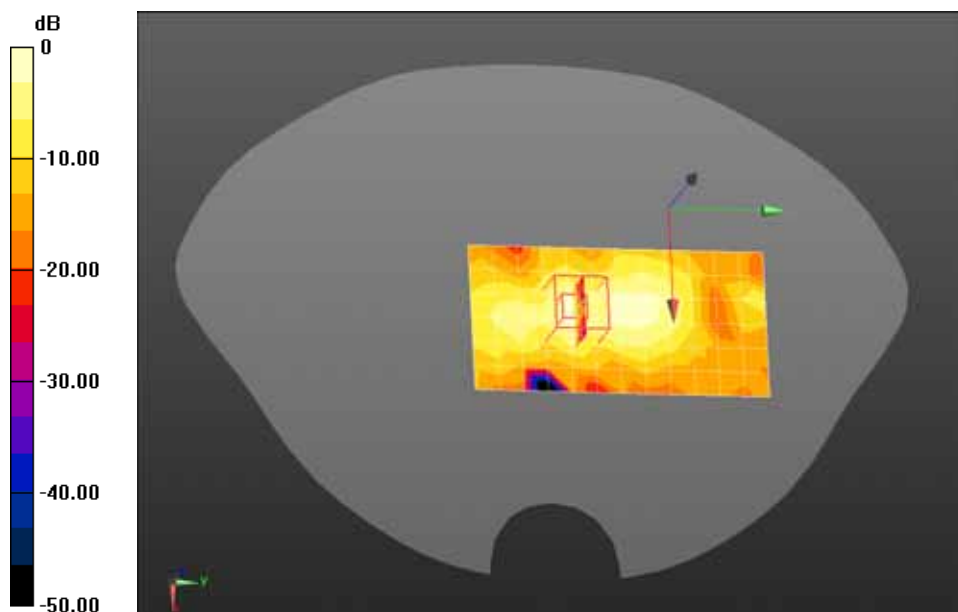

0 dB = 0.906 mW/g = -0.86 dB mW/g

Date/Time: 10-03-2014

Test Laboratory: QuieTek Lab

802.11n(20) 5825MHz Vertical Front-ant (0+1)

DUT: IP-STB; Type: 3500X

Communication System: CW; Communication System Band: 5GHz(5000.0-6000.0MHz); Duty Cycle: 1:1.0;
 Frequency: 5825 MHz; Medium parameters used: $f = 5825 \text{ MHz}$; $\sigma = 6.08 \text{ mho/m}$; $\epsilon_r = 47.23$; $\rho = 1000 \text{ kg/m}^3$; Phantom section: Flat Section

Ambient temperature (): 21.5, Liquid temperature (): 21.0

DASY5 Configuration:

- Probe: EX3DV4 - SN3962; ConvF(3.96, 3.96, 3.96); Calibrated: 10/12/2013;
- Sensor-Surface: 2mm (Mechanical Surface Detection)
- Electronics: DAE4 Sn1220; Calibrated: 22/01/2014
- Phantom: SAM1; Type: SAM; Serial: TP1561
- Measurement SW: DASY52, Version 52.8 (1); SEMCAD X Version 14.6.5 (6469)

Configuration/802.11n(20) 5825MHz Vertical Front/Area Scan (7x13x1): Measurement grid: $dx=10\text{mm}$, $dy=10\text{mm}$

Maximum value of SAR (measured) = 0.422 mW/g

Configuration/802.11n(20) 5825MHz Vertical Front/Zoom Scan (6x6x6)/Cube 0: Measurement grid: $dx=5\text{mm}$, $dy=5\text{mm}$, $dz=2\text{mm}$, Reference Value = 2.179 V/m; Power Drift = 0.16 dB

Peak SAR (extrapolated) = 1.264 mW/g

SAR(1 g) = 0.273 mW/g; SAR(10 g) = 0.067 mW/g, Maximum value of SAR (measured) = 0.667 mW/g

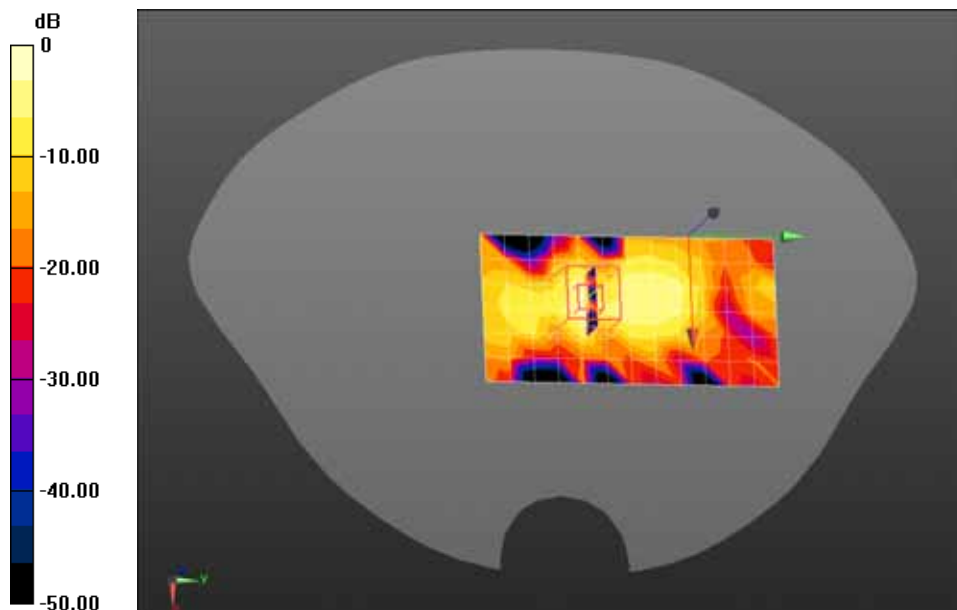

0 dB = 0.667 mW/g = -3.52 dB mW/g

Date/Time: 10-03-2014

Test Laboratory: QuieTek Lab

802.11n(40) 5795MHz Vertical Front-ant (0+1)

DUT: IP-STB; Type: 3500X

Communication System: CW; Communication System Band: 5GHz(5000.0-6000.0MHz); Duty Cycle: 1:1.0; Frequency: 5795 MHz; Medium parameters used: $f = 5795$ MHz; $\sigma = 6.03$ mho/m; $\epsilon_r = 47.3$; $\rho = 1000$ kg/m³; Phantom section: Flat Section

Ambient temperature (): 21.5, Liquid temperature (): 21.0

DASY5 Configuration:

- Probe: EX3DV4 - SN3962; ConvF(3.96, 3.96, 3.96); Calibrated: 10/12/2013;
- Sensor-Surface: 2mm (Mechanical Surface Detection)
- Electronics: DAE4 Sn1220; Calibrated: 22/01/2014
- Phantom: SAM1; Type: SAM; Serial: TP1561
- Measurement SW: DASY52, Version 52.8 (1); SEMCAD X Version 14.6.5 (6469)

Configuration/802.11n(40) 5795MHz Vertical Front/Area Scan (7x13x1): Measurement grid: dx=10mm, dy=10mm

Maximum value of SAR (measured) = 0.880 mW/g

Configuration/802.11n(40) 5795MHz Vertical Front/Zoom Scan (6x6x6)/Cube 0: Measurement grid: dx=5mm, dy=5mm, dz=2mm, Reference Value = 4.489 V/m; Power Drift = 0.15 dB

Peak SAR (extrapolated) = 2.973 mW/g

SAR(1 g) = 0.490 mW/g; SAR(10 g) = 0.106 mW/g, Maximum value of SAR (measured) = 1.03 mW/g

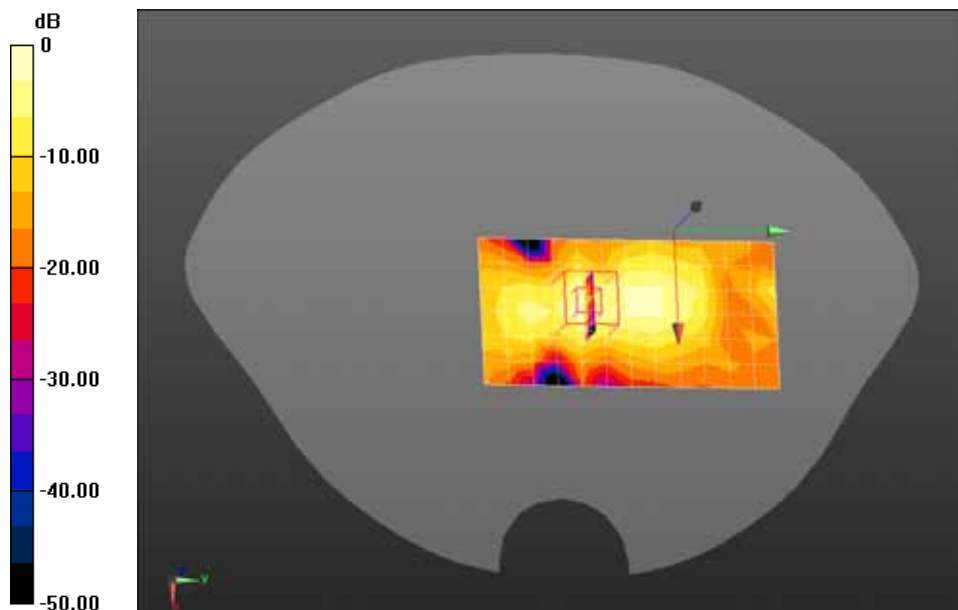

0 dB = 1.03 mW/g = 0.26 dB mW/g

Appendix C. Test Setup Photographs & EUT Photographs

Appendix D. Probe Calibration Data

**Calibration Laboratory of
Schmid & Partner
Engineering AG**
Zeughausstrasse 43, 8004 Zurich, Switzerland



S Schweizerischer Kalibrierdienst
C Service suisse d'étalonnage
S Servizio svizzero di taratura
S Swiss Calibration Service

Accredited by the Swiss Accreditation Service (SAS)
The Swiss Accreditation Service is one of the signatories to the EA
Multilateral Agreement for the recognition of calibration certificates

Accreditation No.: **SCS 108**

Client **SGS-SZ (Auden)**

Certificate No: **EX3-3962_Dec13**

CALIBRATION CERTIFICATE	
Object	EX3DV4 - SN:3962
Calibration procedure(s)	QA CAL-01.v9, QA CAL-14.v4, QA CAL-23.v5, QA CAL-25.v6 Calibration procedure for dosimetric E-field probes
Calibration date:	December 10, 2013
This calibration certificate documents the traceability to national standards, which realize the physical units of measurements (SI). The measurements and the uncertainties with confidence probability are given on the following pages and are part of the certificate.	
All calibrations have been conducted in the closed laboratory facility: environment temperature (22 ± 3)°C and humidity < 70%.	
Calibration Equipment used (M&TE critical for calibration)	

Primary Standards	ID	Cal Date (Certificate No.)	Scheduled Calibration
Power meter E4419B	GR41293R74	04-Apr-13 (No. 217-01733)	Apr-14
Power sensor E4412A	MY41498087	04-Apr-13 (No. 217-01733)	Apr-14
Reference 3 dB Attenuator	SN: S5054 (3c)	04-Apr-13 (No. 217-01737)	Apr-14
Reference 20 dB Attenuator	SN: S5277 (20x)	04-Apr-13 (No. 217-01735)	Apr-14
Reference 30 dB Attenuator	SN: S5129 (30b)	04-Apr-13 (No. 217-01738)	Apr-14
Reference Probe ES3DV2	SN: 3013	28-Dec-12 (No. ES3-3013_Dec12)	Dec-13
DAE4	SN: 660	4-Sep-13 (No. DAE4-660_Sep13)	Sep-14
Secondary Standards	ID	Check Date (in house)	Scheduled Check
RF generator HP 8648C	US3642U01700	4-Aug-99 (in house check Apr-13)	In house check: Apr-15
Network Analyzer HP 8753E	US37390585	18-Oct-01 (in house check Oct-13)	In house check: Oct-14

Calibrated by:	Name Claudio Leubler	Function Laboratory Technician	Signature
Approved by:	Katja Pokovic	Technical Manager	
This calibration certificate shall not be reproduced except in full without written approval of the laboratory.			Issued: December 11, 2013

**Calibration Laboratory of
Schmid & Partner
Engineering AG**
Zeughausstrasse 43, 8004 Zurich, Switzerland



S Schweizerischer Kalibrierdienst
C Service suisse d'étalonnage
S Servizio svizzero di taratura
S Swiss Calibration Service

Accredited by the Swiss Accreditation Service (SAS)
The Swiss Accreditation Service is one of the signatories to the EA
Multilateral Agreement for the recognition of calibration certificates

Accreditation No.: **SCS 108**

Glossary:

TSL	tissue simulating liquid
NORM _{x,y,z}	sensitivity in free space
ConvF	sensitivity in TSL / NORM _{x,y,z}
DCP	diode compression point
CF	crest factor (1/duty_cycle) of the RF signal
A, B, C, D	modulation dependent linearization parameters
Polarization φ	φ rotation around probe axis
Polarization ϑ	ϑ rotation around an axis that is in the plane normal to probe axis (at measurement center), i.e., $\vartheta = 0$ is normal to probe axis
Connector Angle	information used in DASY system to align probe sensor X to the robot coordinate system

Calibration is Performed According to the Following Standards:

- a) IEEE Std 1528-2013, "IEEE Recommended Practice for Determining the Peak Spatial-Averaged Specific Absorption Rate (SAR) in the Human Head from Wireless Communications Devices: Measurement Techniques", June 2013
- b) IEC 62209-1, "Procedure to measure the Specific Absorption Rate (SAR) for hand-held devices used in close proximity to the ear (frequency range of 300 MHz to 3 GHz)", February 2005

Methods Applied and Interpretation of Parameters:

- **NORM_{x,y,z}**: Assessed for E-field polarization $\vartheta = 0$ ($f \leq 900$ MHz in TEM-cell; $f > 1800$ MHz: R22 waveguide). NORM_{x,y,z} are only intermediate values, i.e., the uncertainties of NORM_{x,y,z} does not affect the E²-field uncertainty inside TSL (see below ConvF).
- **NORM(f)_{x,y,z} = NORM_{x,y,z} * frequency_response** (see Frequency Response Chart). This linearization is implemented in DASY4 software versions later than 4.2. The uncertainty of the frequency response is included in the stated uncertainty of ConvF.
- **DCP_{x,y,z}**: DCP are numerical linearization parameters assessed based on the data of power sweep with CW signal (no uncertainty required). DCP does not depend on frequency nor media.
- **PAR**: PAR is the Peak to Average Ratio that is not calibrated but determined based on the signal characteristics
- **A_{x,y,z}; B_{x,y,z}; C_{x,y,z}; D_{x,y,z}; VR_{x,y,z}; A, B, C, D** are numerical linearization parameters assessed based on the data of power sweep for specific modulation signal. The parameters do not depend on frequency nor media. VR is the maximum calibration range expressed in RMS voltage across the diode.
- **ConvF and Boundary Effect Parameters**: Assessed in flat phantom using E-field (or Temperature Transfer Standard for $f \leq 800$ MHz) and inside waveguide using analytical field distributions based on power measurements for $f > 800$ MHz. The same setups are used for assessment of the parameters applied for boundary compensation (alpha, depth) of which typical uncertainty values are given. These parameters are used in DASY4 software to improve probe accuracy close to the boundary. The sensitivity in TSL corresponds to NORM_{x,y,z} * ConvF whereby the uncertainty corresponds to that given for ConvF. A frequency dependent ConvF is used in DASY version 4.4 and higher which allows extending the validity from ± 50 MHz to ± 100 MHz.
- **Spherical isotropy (3D deviation from isotropy)**: in a field of low gradients realized using a flat phantom exposed by a patch antenna.
- **Sensor Offset**: The sensor offset corresponds to the offset of virtual measurement center from the probe tip (on probe axis). No tolerance required.
- **Connector Angle**: The angle is assessed using the information gained by determining the NORM_x (no uncertainty required).

EX3DV4 – SN:3962

December 10, 2013

Probe EX3DV4

SN:3962

Manufactured: September 30, 2013
Calibrated: December 10, 2013

Calibrated for DASY/EASY Systems
(Note: non-compatible with DASY2 system!)

EX3DV4- SN:3962

December 10, 2013

DASY/EASY - Parameters of Probe: EX3DV4 - SN:3962

Basic Calibration Parameters

	Sensor X	Sensor Y	Sensor Z	Unc (k=2)
Norm ($\mu\text{V}/(\text{V}/\text{m})^2$) ^A	0.39	0.48	0.43	$\pm 10.1\%$
DCP (mV) ^B	98.5	93.1	90.7	

Modulation Calibration Parameters

UID	Communication System Name		A dB	B dB $\sqrt{\mu\text{V}}$	C	D dB	VR mV	Unc ^E (k=2)
0	CW	X	0.0	0.0	1.0	0.00	134.3	$\pm 3.3\%$
		Y	0.0	0.0	1.0		163.4	
		Z	0.0	0.0	1.0		146.1	

The reported uncertainty of measurement is stated as the standard uncertainty of measurement multiplied by the coverage factor k=2, which for a normal distribution corresponds to a coverage probability of approximately 95%.

^A The uncertainties of NormX,Y,Z do not affect the E²-field uncertainty inside TSL (see Pages 5 and 6).

^B Numerical linearization parameter: uncertainty not required.

^E Uncertainty is determined using the max. deviation from linear response applying rectangular distribution and is expressed for the square of the field value.

EX3DV4- SN:3962

December 10, 2013

DASY/EASY - Parameters of Probe: EX3DV4 - SN:3962

Calibration Parameter Determined in Head Tissue Simulating Media

f (MHz) ^C	Relative Permittivity ^F	Conductivity (S/m) ^F	ConvF X	ConvF Y	ConvF Z	Alpha ^G	Depth ^G (mm)	Unct. (k=2)
850	41.5	0.92	10.14	10.14	10.14	0.32	0.97	± 12.0 %
1810	40.0	1.40	8.14	8.14	8.14	0.65	0.64	± 12.0 %
1900	40.0	1.40	8.07	8.07	8.07	0.62	0.62	± 12.0 %
2000	40.0	1.40	8.11	8.11	8.11	0.50	0.69	± 12.0 %
2450	39.2	1.80	7.33	7.33	7.33	0.28	0.93	± 12.0 %
5200	36.0	4.66	5.25	5.25	5.25	0.30	1.80	± 13.1 %
5300	35.9	4.76	5.00	5.00	5.00	0.30	1.80	± 13.1 %
5500	35.6	4.96	4.80	4.80	4.80	0.35	1.80	± 13.1 %
5600	35.5	5.07	4.71	4.71	4.71	0.30	1.80	± 13.1 %
5800	35.3	5.27	4.65	4.65	4.65	0.40	1.80	± 13.1 %

^C Frequency validity of ± 100 MHz only applies for DASY v4.4 and higher (see Page 2), else it is restricted to ± 50 MHz. The uncertainty is the RSS of the ConvF uncertainty at calibration frequency and the uncertainty for the indicated frequency band.

^F At frequencies below 3 GHz, the validity of tissue parameters (ϵ and σ) can be relaxed to ± 10% if liquid compensation formula is applied to measured SAR values. At frequencies above 3 GHz, the validity of tissue parameters (ϵ and σ) is restricted to ± 5%. The uncertainty is the RSS of the ConvF uncertainty for indicated target tissue parameters.

^G Alpha/Depth are determined during calibration. SPEAG warrants that the remaining deviation due to the boundary effect after compensation is always less than ± 1% for frequencies below 3 GHz and below ± 2% for frequencies between 3-6 GHz at any distance larger than half the probe tip diameter from the boundary.

EX3DV4- SN:3962

December 10, 2013

DASY/EASY - Parameters of Probe: EX3DV4 - SN:3962

Calibration Parameter Determined in Body Tissue Simulating Media

f (MHz) ^C	Relative Permittivity ^F	Conductivity (S/m) ^F	ConvF X	ConvF Y	ConvF Z	Alpha ^G	Depth ^G (mm)	Unct. (k=2)
850	55.2	0.99	9.75	9.75	9.75	0.33	1.01	± 12.0 %
1810	53.3	1.52	8.01	8.01	8.01	0.36	0.84	± 12.0 %
1900	53.3	1.52	7.68	7.68	7.68	0.59	0.65	± 12.0 %
2450	52.7	1.95	7.13	7.13	7.13	0.65	0.50	± 12.0 %
5200	49.0	5.30	4.18	4.18	4.18	0.45	1.90	± 13.1 %
5300	48.9	5.42	4.09	4.09	4.09	0.45	1.90	± 13.1 %
5500	48.6	5.65	3.91	3.91	3.91	0.45	1.90	± 13.1 %
5600	48.5	5.77	3.60	3.60	3.60	0.55	1.90	± 13.1 %
5800	48.2	6.00	3.96	3.96	3.96	0.50	1.90	± 13.1 %

^C Frequency validity of ± 100 MHz only applies for DASY v4.4 and higher (see Page 2), else it is restricted to ± 50 MHz. The uncertainty is the RSS of the ConvF uncertainty at calibration frequency and the uncertainty for the indicated frequency band.

^F At frequencies below 3 GHz, the validity of tissue parameters (ϵ and σ) can be relaxed to ± 10% if liquid compensation formula is applied to measured SAR values. At frequencies above 3 GHz, the validity of tissue parameters (ϵ and σ) is restricted to ± 5%. The uncertainty is the RSS of the ConvF uncertainty for indicated target tissue parameters.

^G Alpha/Depth are determined during calibration. SPEAG warrants that the remaining deviation due to the boundary effect after compensation is always less than ± 1% for frequencies below 3 GHz and below ± 2% for frequencies between 3-6 GHz at any distance larger than half the probe tip diameter from the boundary.

EX3DV4- SN:3962

December 10, 2013

Frequency Response of E-Field (TEM-Cell:ifi110 EXX, Waveguide: R22)

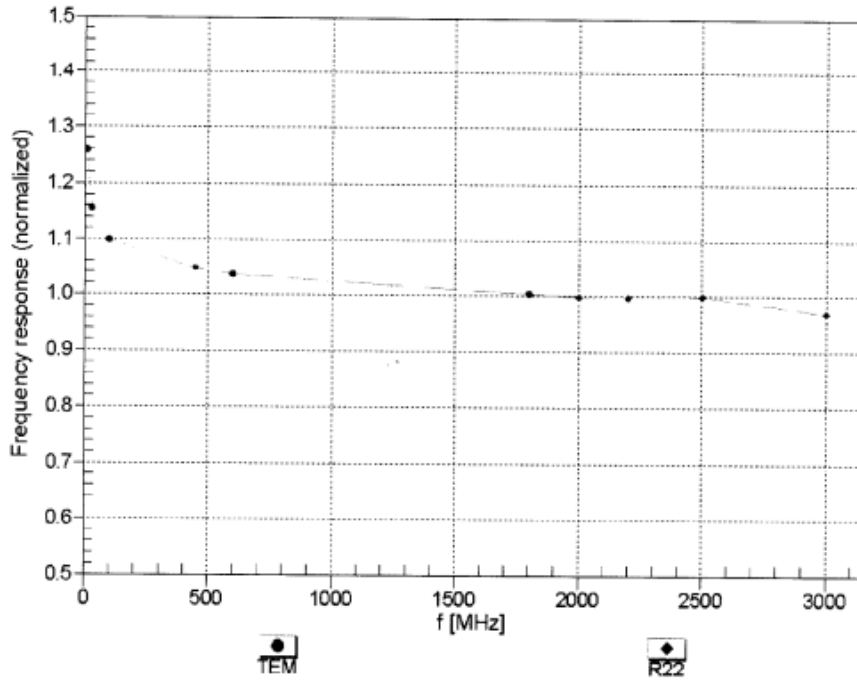

Uncertainty of Frequency Response of E-field: $\pm 6.3\%$ (k=2)

EX3DV4- SN:3962

December 10, 2013

Receiving Pattern (ϕ), $\theta = 0^\circ$

f=600 MHz,TEM

f=1800 MHz,R22

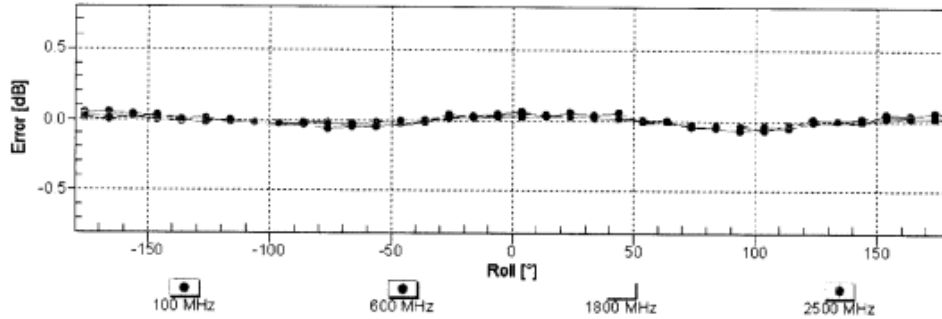
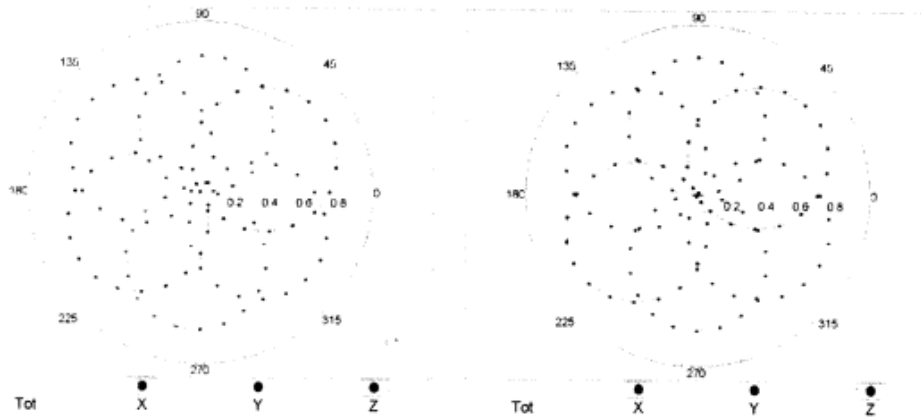

Uncertainty of Axial Isotropy Assessment: $\pm 0.5\%$ (k=2)

EX3DV4- SN:3962

December 10, 2013

Dynamic Range $f(SAR_{head})$
 (TEM cell , $f = 900$ MHz)

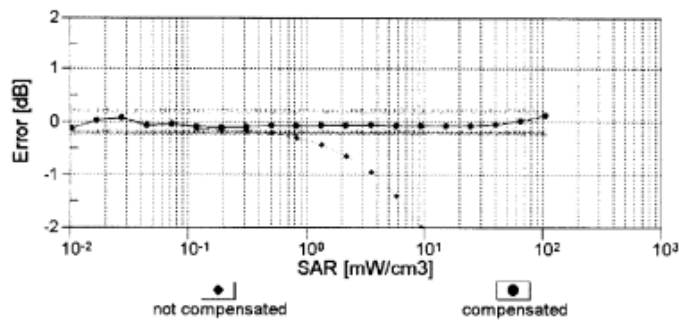
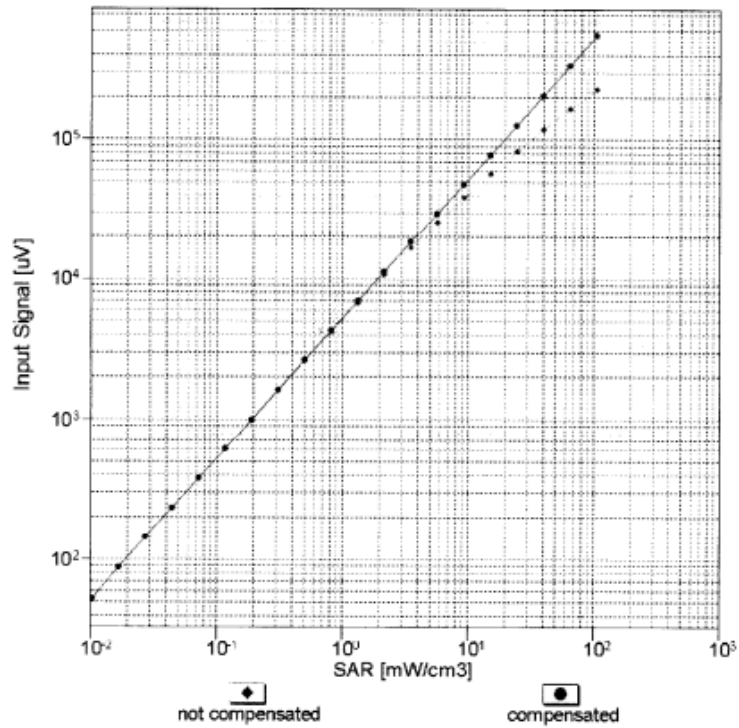

Uncertainty of Linearity Assessment: $\pm 0.6\%$ ($k=2$)

EX3DV4- SN:3962

December 10, 2013

Conversion Factor Assessment

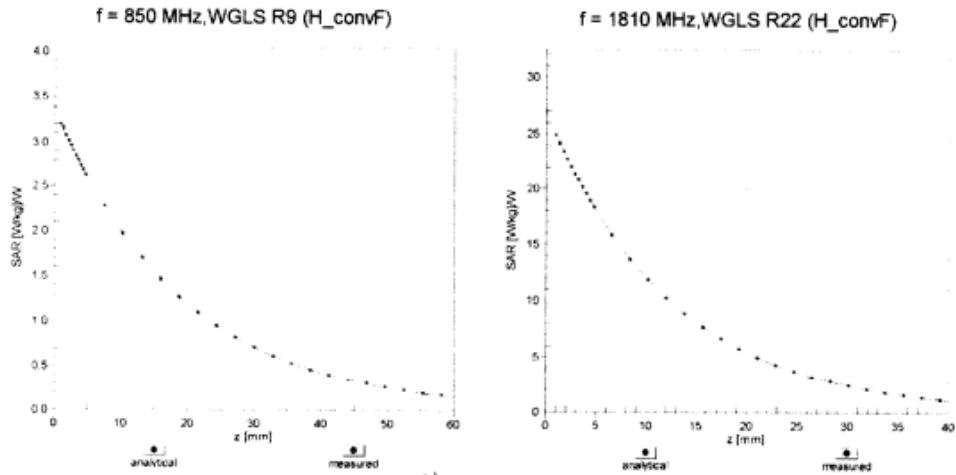

Deviation from Isotropy in Liquid

Error (ϕ, θ), f = 900 MHz

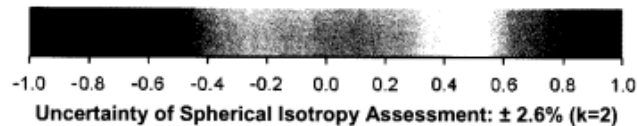
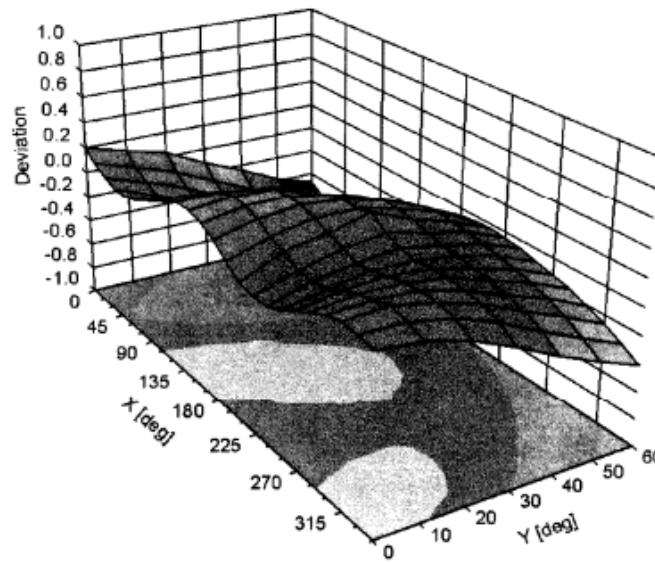

EX3DV4- SN:3962

December 10, 2013

DASY/EASY - Parameters of Probe: EX3DV4 - SN:3962

Other Probe Parameters

Sensor Arrangement	Triangular
Connector Angle (°)	-26.3
Mechanical Surface Detection Mode	enabled
Optical Surface Detection Mode	disabled
Probe Overall Length	337 mm
Probe Body Diameter	10 mm
Tip Length	9 mm
Tip Diameter	2.5 mm
Probe Tip to Sensor X Calibration Point	1 mm
Probe Tip to Sensor Y Calibration Point	1 mm
Probe Tip to Sensor Z Calibration Point	1 mm
Recommended Measurement Distance from Surface	2 mm

Appendix E. Dipole Calibration Data

**Calibration Laboratory of
Schmid & Partner
Engineering AG**
Zeughausstrasse 43, 8004 Zurich, Switzerland



S Schweizerischer Kalibrierdienst
S Service suisse d'étalonnage
C Servizio svizzero di taratura
S Swiss Calibration Service

Accredited by the Swiss Accreditation Service (SAS)
The Swiss Accreditation Service is one of the signatories to the EA
Multilateral Agreement for the recognition of calibration certificates

Accreditation No.: **SCS 108**

Client **Auden**

Certificate No: **D2450V2-735_Jun13**

CALIBRATION CERTIFICATE																																															
Object	D2450V2 - SN: 735																																														
Calibration procedure(s)	QA CAL-05.v9 Calibration procedure for dipole validation kits above 700 MHz																																														
Calibration date:	June 11, 2013																																														
<p>This calibration certificate documents the traceability to national standards, which realize the physical units of measurements (SI). The measurements and the uncertainties with confidence probability are given on the following pages and are part of the certificate.</p> <p>All calibrations have been conducted in the closed laboratory facility: environment temperature (22 ± 3)°C and humidity < 70%.</p> <p>Calibration Equipment used (M&TE critical for calibration)</p> <table border="1"> <thead> <tr> <th>Primary Standards</th> <th>ID #</th> <th>Cal Date (Certificate No.)</th> <th>Scheduled Calibration</th> </tr> </thead> <tbody> <tr> <td>Power meter EPM-442A</td> <td>GB37480704</td> <td>01-Nov-12 (No. 217-01640)</td> <td>Oct-13</td> </tr> <tr> <td>Power sensor HP 8481A</td> <td>US37292783</td> <td>01-Nov-12 (No. 217-01640)</td> <td>Oct-13</td> </tr> <tr> <td>Reference 20 dB Attenuator</td> <td>SN: 5058 (20k)</td> <td>04-Apr-13 (No. 217-01736)</td> <td>Apr-14</td> </tr> <tr> <td>Type-N mismatch combination</td> <td>SN: 5047.3 / 06327</td> <td>04-Apr-13 (No. 217-01739)</td> <td>Apr-14</td> </tr> <tr> <td>Reference Probe ES3DV3</td> <td>SN: 3205</td> <td>28-Dec-12 (No. ES3-3205_Dec12)</td> <td>Dec-13</td> </tr> <tr> <td>DAE4</td> <td>SN: 601</td> <td>25-Apr-13 (No. DAE4-601_Apr13)</td> <td>Apr-14</td> </tr> </tbody> </table> <table border="1"> <thead> <tr> <th>Secondary Standards</th> <th>ID #</th> <th>Check Date (in house)</th> <th>Scheduled Check</th> </tr> </thead> <tbody> <tr> <td>Power sensor HP 8481A</td> <td>MY41092317</td> <td>18-Oct-02 (in house check Oct-11)</td> <td>In house check: Oct-13</td> </tr> <tr> <td>RF generator R&S SMT-06</td> <td>100005</td> <td>04-Aug-99 (in house check Oct-11)</td> <td>In house check: Oct-13</td> </tr> <tr> <td>Network Analyzer HP 8753E</td> <td>US37390585 S4206</td> <td>18-Oct-01 (in house check Oct-12)</td> <td>In house check: Oct-13</td> </tr> </tbody> </table>				Primary Standards	ID #	Cal Date (Certificate No.)	Scheduled Calibration	Power meter EPM-442A	GB37480704	01-Nov-12 (No. 217-01640)	Oct-13	Power sensor HP 8481A	US37292783	01-Nov-12 (No. 217-01640)	Oct-13	Reference 20 dB Attenuator	SN: 5058 (20k)	04-Apr-13 (No. 217-01736)	Apr-14	Type-N mismatch combination	SN: 5047.3 / 06327	04-Apr-13 (No. 217-01739)	Apr-14	Reference Probe ES3DV3	SN: 3205	28-Dec-12 (No. ES3-3205_Dec12)	Dec-13	DAE4	SN: 601	25-Apr-13 (No. DAE4-601_Apr13)	Apr-14	Secondary Standards	ID #	Check Date (in house)	Scheduled Check	Power sensor HP 8481A	MY41092317	18-Oct-02 (in house check Oct-11)	In house check: Oct-13	RF generator R&S SMT-06	100005	04-Aug-99 (in house check Oct-11)	In house check: Oct-13	Network Analyzer HP 8753E	US37390585 S4206	18-Oct-01 (in house check Oct-12)	In house check: Oct-13
Primary Standards	ID #	Cal Date (Certificate No.)	Scheduled Calibration																																												
Power meter EPM-442A	GB37480704	01-Nov-12 (No. 217-01640)	Oct-13																																												
Power sensor HP 8481A	US37292783	01-Nov-12 (No. 217-01640)	Oct-13																																												
Reference 20 dB Attenuator	SN: 5058 (20k)	04-Apr-13 (No. 217-01736)	Apr-14																																												
Type-N mismatch combination	SN: 5047.3 / 06327	04-Apr-13 (No. 217-01739)	Apr-14																																												
Reference Probe ES3DV3	SN: 3205	28-Dec-12 (No. ES3-3205_Dec12)	Dec-13																																												
DAE4	SN: 601	25-Apr-13 (No. DAE4-601_Apr13)	Apr-14																																												
Secondary Standards	ID #	Check Date (in house)	Scheduled Check																																												
Power sensor HP 8481A	MY41092317	18-Oct-02 (in house check Oct-11)	In house check: Oct-13																																												
RF generator R&S SMT-06	100005	04-Aug-99 (in house check Oct-11)	In house check: Oct-13																																												
Network Analyzer HP 8753E	US37390585 S4206	18-Oct-01 (in house check Oct-12)	In house check: Oct-13																																												
Calibrated by:	Name Leif Klysner	Function Laboratory Technician	Signature 																																												
Approved by:	Name Katja Pokovic	Function Technical Manager	Signature 																																												
			Issued: June 11, 2013																																												
This calibration certificate shall not be reproduced except in full without written approval of the laboratory.																																															

**Calibration Laboratory of
Schmid & Partner
Engineering AG**
Zeughausstrasse 43, 8004 Zurich, Switzerland



S Schweizerischer Kalibrierdienst
S Service suisse d'étalonnage
C Servizio svizzero di taratura
S Swiss Calibration Service

Accredited by the Swiss Accreditation Service (SAS)
The Swiss Accreditation Service is one of the signatories to the EA
Multilateral Agreement for the recognition of calibration certificates

Accreditation No.: **SCS 108**

Glossary:

TSL tissue simulating liquid
ConvF sensitivity in TSL / NORM x,y,z
N/A not applicable or not measured

Calibration is Performed According to the Following Standards:

- a) IEEE Std 1528-2003, "IEEE Recommended Practice for Determining the Peak Spatial-Averaged Specific Absorption Rate (SAR) in the Human Head from Wireless Communications Devices: Measurement Techniques", December 2003
- b) IEC 62209-1, "Procedure to measure the Specific Absorption Rate (SAR) for hand-held devices used in close proximity to the ear (frequency range of 300 MHz to 3 GHz)", February 2005
- c) Federal Communications Commission Office of Engineering & Technology (FCC OET), "Evaluating Compliance with FCC Guidelines for Human Exposure to Radiofrequency Electromagnetic Fields; Additional Information for Evaluating Compliance of Mobile and Portable Devices with FCC Limits for Human Exposure to Radiofrequency Emissions", Supplement C (Edition 01-01) to Bulletin 65

Additional Documentation:

- d) DASY4/5 System Handbook

Methods Applied and Interpretation of Parameters:

- *Measurement Conditions:* Further details are available from the Validation Report at the end of the certificate. All figures stated in the certificate are valid at the frequency indicated.
- *Antenna Parameters with TSL:* The dipole is mounted with the spacer to position its feed point exactly below the center marking of the flat phantom section, with the arms oriented parallel to the body axis.
- *Feed Point Impedance and Return Loss:* These parameters are measured with the dipole positioned under the liquid filled phantom. The impedance stated is transformed from the measurement at the SMA connector to the feed point. The Return Loss ensures low reflected power. No uncertainty required.
- *Electrical Delay:* One-way delay between the SMA connector and the antenna feed point. No uncertainty required.
- *SAR measured:* SAR measured at the stated antenna input power.
- *SAR normalized:* SAR as measured, normalized to an input power of 1 W at the antenna connector.
- *SAR for nominal TSL parameters:* The measured TSL parameters are used to calculate the nominal SAR result.

The reported uncertainty of measurement is stated as the standard uncertainty of measurement multiplied by the coverage factor $k=2$, which for a normal distribution corresponds to a coverage probability of approximately 95%.

Measurement Conditions

DASY system configuration, as far as not given on page 1.

DASY Version	DASY5	V52.8.7
Extrapolation	Advanced Extrapolation	
Phantom	Modular Flat Phantom	
Distance Dipole Center - TSL	10 mm	with Spacer
Zoom Scan Resolution	dx, dy, dz = 5 mm	
Frequency	2450 MHz ± 1 MHz	

Head TSL parameters

The following parameters and calculations were applied.

	Temperature	Permittivity	Conductivity
Nominal Head TSL parameters	22.0 °C	39.2	1.80 mho/m
Measured Head TSL parameters	(22.0 ± 0.2) °C	37.8 ± 6 %	1.81 mho/m ± 6 %
Head TSL temperature change during test	< 0.5 °C	----	----

SAR result with Head TSL

SAR averaged over 1 cm ³ (1 g) of Head TSL	Condition	
SAR measured	250 mW input power	13.3 W/kg
SAR for nominal Head TSL parameters	normalized to 1W	52.6 W/kg ± 17.0 % (k=2)

SAR averaged over 10 cm ³ (10 g) of Head TSL	condition	
SAR measured	250 mW input power	6.19 W/kg
SAR for nominal Head TSL parameters	normalized to 1W	24.6 W/kg ± 16.5 % (k=2)

Body TSL parameters

The following parameters and calculations were applied.

	Temperature	Permittivity	Conductivity
Nominal Body TSL parameters	22.0 °C	52.7	1.95 mho/m
Measured Body TSL parameters	(22.0 ± 0.2) °C	50.9 ± 6 %	2.02 mho/m ± 6 %
Body TSL temperature change during test	< 0.5 °C	----	----

SAR result with Body TSL

SAR averaged over 1 cm ³ (1 g) of Body TSL	Condition	
SAR measured	250 mW input power	13.3 W/kg
SAR for nominal Body TSL parameters	normalized to 1W	51.9 W/kg ± 17.0 % (k=2)

SAR averaged over 10 cm ³ (10 g) of Body TSL	condition	
SAR measured	250 mW input power	6.13 W/kg
SAR for nominal Body TSL parameters	normalized to 1W	24.2 W/kg ± 16.5 % (k=2)

Appendix

Antenna Parameters with Head TSL

Impedance, transformed to feed point	55.5 Ω + 4.3 jΩ
Return Loss	- 23.6 dB

Antenna Parameters with Body TSL

Impedance, transformed to feed point	50.5 Ω + 5.5 jΩ
Return Loss	- 25.2 dB

General Antenna Parameters and Design

Electrical Delay (one direction)	1.153 ns
----------------------------------	----------

After long term use with 100W radiated power, only a slight warming of the dipole near the feedpoint can be measured.

The dipole is made of standard semirigid coaxial cable. The center conductor of the feeding line is directly connected to the second arm of the dipole. The antenna is therefore short-circuited for DC-signals. On some of the dipoles, small end caps are added to the dipole arms in order to improve matching when loaded according to the position as explained in the "Measurement Conditions" paragraph. The SAR data are not affected by this change. The overall dipole length is still according to the Standard.

No excessive force must be applied to the dipole arms, because they might bend or the soldered connections near the feedpoint may be damaged.

Additional EUT Data

Manufactured by	SPEAG
Manufactured on	May 07, 2003

DASY5 Validation Report for Head TSL

Date: 11.06.2013

Test Laboratory: SPEAG, Zurich, Switzerland

DUT: Dipole 2450 MHz; Type: D2450V2; Serial: D2450V2 - SN: 735

Communication System: UID 0 - CW ; Frequency: 2450 MHz

Medium parameters used: $f = 2450$ MHz; $\sigma = 1.81$ S/m; $\epsilon_r = 37.8$; $\rho = 1000$ kg/m³

Phantom section: Flat Section

Measurement Standard: DASY5 (IEEE/IEC/ANSI C63.19-2007)

DASY52 Configuration:

- Probe: ES3DV3 - SN3205; ConvF(4.52, 4.52, 4.52); Calibrated: 28.12.2012;
- Sensor-Surface: 3mm (Mechanical Surface Detection)
- Electronics: DAE4 Sn601; Calibrated: 25.04.2013
- Phantom: Flat Phantom 5.0 (front); Type: QD000P50AA; Serial: 1001
- DASY52 52.8.7(1137); SEMCAD X 14.6.10(7164)

Dipole Calibration for Head Tissue/Pin=250 mW, d=10mm/Zoom Scan (7x7x7)/Cube 0:

Measurement grid: dx=5mm, dy=5mm, dz=5mm

Reference Value = 95.127 V/m; Power Drift = 0.06 dB

Peak SAR (extrapolated) = 27.7 W/kg

SAR(1 g) = 13.3 W/kg; SAR(10 g) = 6.19 W/kg

Maximum value of SAR (measured) = 16.9 W/kg

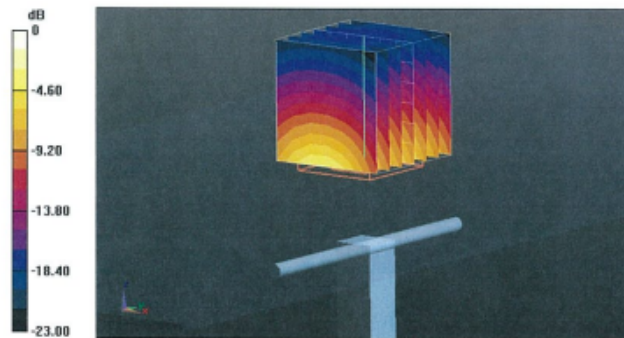

0 dB = 16.9 W/kg = 12.28 dBW/kg

Impedance Measurement Plot for Head TSL

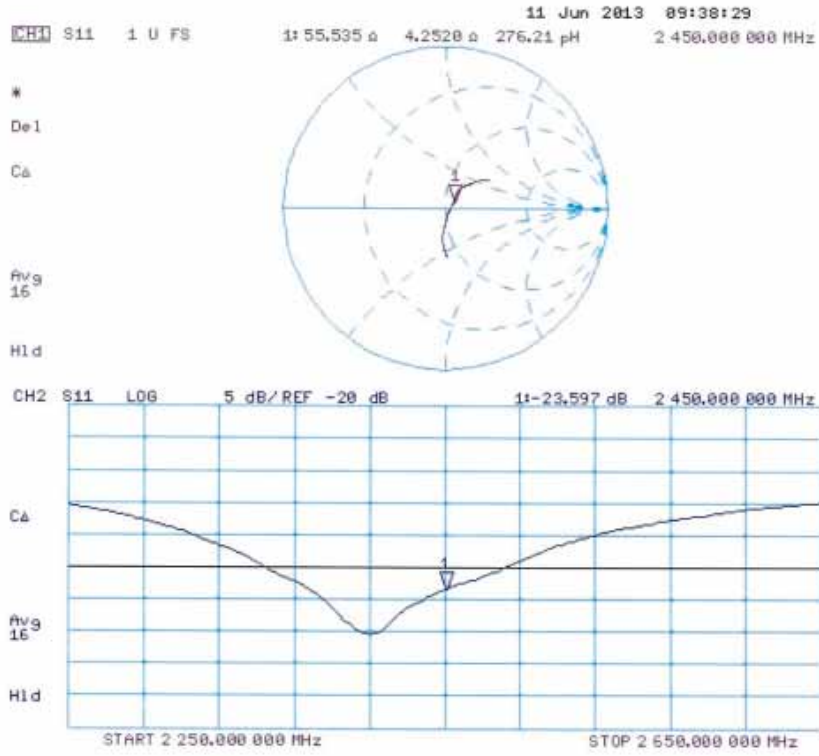

DASY5 Validation Report for Body TSL

Date: 11.06.2013

Test Laboratory: SPEAG, Zurich, Switzerland

DUT: Dipole 2450 MHz; Type: D2450V2; Serial: D2450V2 - SN: 735

Communication System: UID 0 - CW ; Frequency: 2450 MHz

Medium parameters used: $f = 2450$ MHz; $\sigma = 2.02$ S/m; $\epsilon_r = 50.9$; $\rho = 1000$ kg/m³

Phantom section: Flat Section

Measurement Standard: DASY5 (IEEE/IEC/ANSI C63.19-2007)

DASY52 Configuration:

- Probe: ES3DV3 - SN3205; ConvF(4.42, 4.42, 4.42); Calibrated: 28.12.2012;
- Sensor-Surface: 3mm (Mechanical Surface Detection)
- Electronics: DAE4 Sn601; Calibrated: 25.04.2013
- Phantom: Flat Phantom 5.0 (back); Type: QD000P50AA; Serial: 1002
- DASY52 52.8.7(1137); SEMCAD X 14.6.10(7164)

Dipole Calibration for Body Tissue/Pin=250 mW, d=10mm/Zoom Scan (7x7x7)/Cube 0:

Measurement grid: dx=5mm, dy=5mm, dz=5mm

Reference Value = 95.127 V/m; Power Drift = 0.04 dB

Peak SAR (extrapolated) = 27.9 W/kg

SAR(1 g) = 13.3 W/kg; SAR(10 g) = 6.13 W/kg

Maximum value of SAR (measured) = 17.3 W/kg

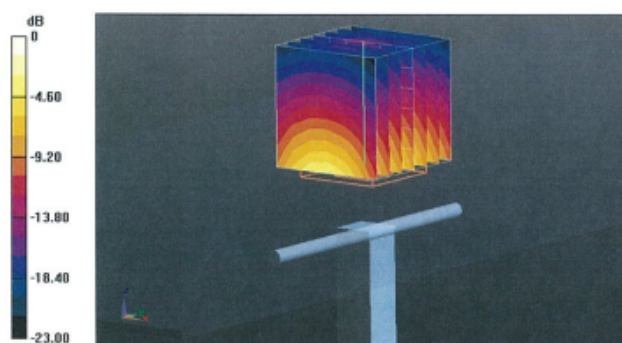

0 dB = 17.3 W/kg = 12.38 dBW/kg

Impedance Measurement Plot for Body TSL

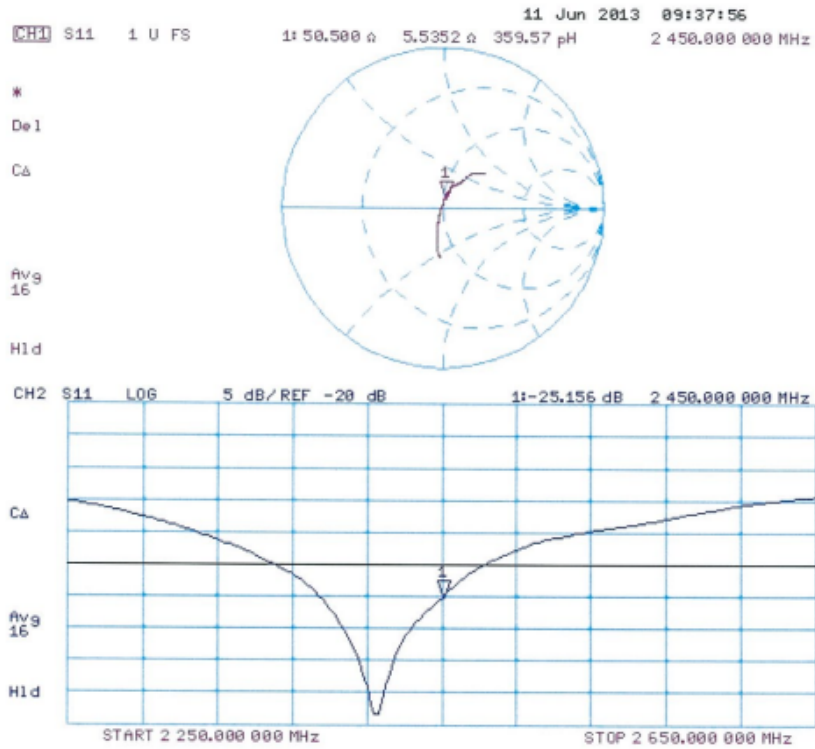

**Calibration Laboratory of
Schmid & Partner
Engineering AG**
Zeughausstrasse 43, 8004 Zurich, Switzerland



S Schweizerischer Kalibrierdienst
C Service suisse d'étalonnage
S Servizio svizzero di taratura
S Swiss Calibration Service

Accredited by the Swiss Accreditation Service (SAS)
The Swiss Accreditation Service is one of the signatories to the EA
Multilateral Agreement for the recognition of calibration certificates

Accreditation No.: **SCS 108**

Client **Auden**

Certificate No: **D5GHzV2-1040_Jul13**

CALIBRATION CERTIFICATE

Object: **D5GHzV2 - SN: 1040**

Calibration procedure(s): **QA CAL-22.v2
Calibration procedure for dipole validation kits between 3-6 GHz**

Calibration date: **July 02, 2013**

This calibration certificate documents the traceability to national standards, which realize the physical units of measurements (SI).
The measurements and the uncertainties with confidence probability are given on the following pages and are part of the certificate.

All calibrations have been conducted in the closed laboratory facility: environment temperature (22 ± 3)°C and humidity < 70%.

Calibration Equipment used (M&TE critical for calibration)

Primary Standards	ID #	Cal Date (Certificate No.)	Scheduled Calibration
Power meter EPM-442A	GB37480704	01-Nov-12 (No. 217-01640)	Oct-13
Power sensor HP 8481A	US37292783	01-Nov-12 (No. 217-01640)	Oct-13
Reference 20 dB Attenuator	SN: 5058 (20k)	04-Apr-13 (No. 217-01736)	Apr-14
Type-N mismatch combination	SN: 5047.3 / 06327	04-Apr-13 (No. 217-01739)	Apr-14
Reference Probe EX3DV4	SN: 3503	28-Dec-12 (No. EX3-3503_Dec12)	Dec-13
DAE4	SN: 601	25-Apr-13 (No. DAE4-601_Apr13)	Apr-14
Secondary Standards	ID #	Check Date (in house)	Scheduled Check
Power sensor HP 8481A	MY41092317	18-Oct-02 (in house check Oct-11)	In house check: Oct-13
RF generator R&S SMT-06	100005	04-Aug-99 (in house check Oct-11)	In house check: Oct-13
Network Analyzer HP 8753E	US37390585 S4206	18-Oct-01 (in house check Oct-12)	In house check: Oct-13

	Name	Function	Signature
Calibrated by:	Israe El-Naouq	Laboratory Technician	
Approved by:	Katja Pokovic	Technical Manager	

Issued: July 2, 2013

This calibration certificate shall not be reproduced except in full without written approval of the laboratory.

**Calibration Laboratory of
Schmid & Partner
Engineering AG**
Zeughausstrasse 43, 8004 Zurich, Switzerland



S Schweizerischer Kalibrierdienst
C Service suisse d'étalonnage
S Servizio svizzero di taratura
S Swiss Calibration Service

Accredited by the Swiss Accreditation Service (SAS)
The Swiss Accreditation Service is one of the signatories to the EA
Multilateral Agreement for the recognition of calibration certificates

Accreditation No.: **SCS 108**

Glossary:

TSL	tissue simulating liquid
ConvF	sensitivity in TSL / NORM x,y,z
N/A	not applicable or not measured

Calibration is Performed According to the Following Standards:

- a) IEC 62209-2, "Evaluation of Human Exposure to Radio Frequency Fields from Handheld and Body-Mounted Wireless Communication Devices in the Frequency Range of 30 MHz to 6 GHz: Human models, Instrumentation, and Procedures"; Part 2: "Procedure to determine the Specific Absorption Rate (SAR) for including accessories and multiple transmitters", March 2010
- b) Federal Communications Commission Office of Engineering & Technology (FCC OET), "Evaluating Compliance with FCC Guidelines for Human Exposure to Radiofrequency Electromagnetic Fields; Additional Information for Evaluating Compliance of Mobile and Portable Devices with FCC Limits for Human Exposure to Radiofrequency Emissions", Supplement C (Edition 01-01) to Bulletin 65

Additional Documentation:

- c) DASY4/5 System Handbook

Methods Applied and Interpretation of Parameters:

- *Measurement Conditions:* Further details are available from the Validation Report at the end of the certificate. All figures stated in the certificate are valid at the frequency indicated.
- *Antenna Parameters with TSL:* The dipole is mounted with the spacer to position its feed point exactly below the center marking of the flat phantom section, with the arms oriented parallel to the body axis.
- *Feed Point Impedance and Return Loss:* These parameters are measured with the dipole positioned under the liquid filled phantom. The impedance stated is transformed from the measurement at the SMA connector to the feed point. The Return Loss ensures low reflected power. No uncertainty required.
- *Electrical Delay:* One-way delay between the SMA connector and the antenna feed point. No uncertainty required.
- *SAR measured:* SAR measured at the stated antenna input power.
- *SAR normalized:* SAR as measured, normalized to an input power of 1 W at the antenna connector.
- *SAR for nominal TSL parameters:* The measured TSL parameters are used to calculate the nominal SAR result.

The reported uncertainty of measurement is stated as the standard uncertainty of measurement multiplied by the coverage factor k=2, which for a normal distribution corresponds to a coverage probability of approximately 95%.

Measurement Conditions

DASY system configuration, as far as not given on page 1.

DASY Version	DASY5	V52.8.7
Extrapolation	Advanced Extrapolation	
Phantom	Modular Flat Phantom V5.0	
Distance Dipole Center - TSL	10 mm	with Spacer
Zoom Scan Resolution	dx, dy = 4.0 mm, dz = 1.4 mm	Graded Ratio = 1.4 (Z direction)
Frequency	5200 MHz ± 1 MHz 5300 MHz ± 1 MHz 5600 MHz ± 1 MHz 5800 MHz ± 1 MHz	

Head TSL parameters at 5200 MHz

The following parameters and calculations were applied.

	Temperature	Permittivity	Conductivity
Nominal Head TSL parameters	22.0 °C	36.0	4.66 mho/m
Measured Head TSL parameters	(22.0 ± 0.2) °C	36.0 ± 6 %	4.47 mho/m ± 6 %
Head TSL temperature change during test	< 0.5 °C	----	----

SAR result with Head TSL at 5200 MHz

SAR averaged over 1 cm³ (1 g) of Head TSL	Condition	
SAR measured	100 mW input power	7.86 W/kg
SAR for nominal Head TSL parameters	normalized to 1W	78.5 W/kg ± 19.9 % (k=2)

SAR averaged over 10 cm³ (10 g) of Head TSL	condition	
SAR measured	100 mW input power	2.24 W/kg
SAR for nominal Head TSL parameters	normalized to 1W	22.4 W/kg ± 19.5 % (k=2)