

TEST REPORT

of

FCC Part 15 Subpart C

& CANADA RSS-210

New Application; Class I PC; Class II PC

Product : 10.1" Tablet PC

Brand: BARTEC

Model: Agile X IS

Model Difference: N/A

FCC ID: TBUAGXISNFC

IC: 5736C-AGXISNFC

FCC Rule Part:



VERIFICATION OF COMPLIANCE

Applicant: BARTEC GmbH
Product Description: 10.1" Tablet PC
Brand Name: BARTEC
Model No.: Agile X IS
Model Difference: N/A
FCC ID: TBUAGXISNFC
IC: 5736C-AGXISNFC
Date of test: 2016/10/26 ~ 2016/11/24
Date of EUT Received: 2016/10/26

We hereby certify that:

All the tests in this report have been performed and recorded in accordance with the standards described above and performed by an independent electromagnetic compatibility consultant, International Standards Laboratory.

The test results contained in this report accurately represent the measurements of the characteristics and the energy generated by sample equipment under test at the time of the test. The sample equipment tested as described in this report is in compliance with the limits of above standards.

Test By: Lake Cheng **Date:** 2016/11/25
Lake Cheng / Engineer

Prepared By: Gigi yeh **Date:** 2016/11/25
Gigi Yeh / Specialist

Approved By: Vincent Su **Date:** 2016/11/25
Vincent Su / Technical Manager

Version

Version No.	Date	Description
00	2016/11/25	Initial creation of document

Table of Contents

1	GENERAL INFORMATION	5
1.1	PRODUCT DESCRIPTION	5
1.2	RELATED SUBMITTAL(S) / GRANT (S)	6
1.3	TEST METHODOLOGY.....	6
1.4	TEST FACILITY	6
1.5	SPECIAL ACCESSORIES	6
1.6	EQUIPMENT MODIFICATIONS	6
2	SYSTEM TEST CONFIGURATION	7
2.1	EUT CONFIGURATION	7
2.2	EUT EXERCISE	7
2.3	TEST PROCEDURE.....	7
2.4	LIMITATION	8
2.5	CONFIGURATION OF TESTED SYSTEM	10
3	SUMMARY OF TEST RESULTS	11
4	DESCRIPTION OF TEST MODES	11
5	CONDUCTED EMISSIONS TEST	12
5.1	MEASUREMENT PROCEDURE:	12
5.2	TEST SET-UP (BLOCK DIAGRAM OF CONFIGURATION)	12
5.3	MEASUREMENT EQUIPMENT USED:	12
5.4	MEASUREMENT RESULT:	12
6	RADIATED EMISSION TEST	15
6.1	MEASUREMENT PROCEDURE.....	15
6.2	TEST SET-UP (BLOCK DIAGRAM OF CONFIGURATION)	15
6.3	MEASUREMENT EQUIPMENT USED:	16
6.4	FIELD STRENGTH CALCULATION	16
6.5	MEASUREMENT RESULT	17
7	FREQUENCY TOLERANCE	20
7.1	MEASUREMENT PROCEDURE.....	20
7.2	TEST SET-UP (BLOCK DIAGRAM OF CONFIGURATION)	20
7.3	MEASUREMENT EQUIPMENT USED:	20
7.4	MEASUREMENT RESULTS.....	20
8	99% BAND WIDTH MEASUREMENT	22
8.1	MEASUREMENT PROCEDURE.....	22
8.2	TEST SET-UP (BLOCK DIAGRAM OF CONFIGURATION)	22
8.3	MEASUREMENT EQUIPMENT USED:	22
8.4	MEASUREMENT RESULTS:.....	22

1 GENERAL INFORMATION

1.1 Product Description

Product Name	10.1" Tablet PC	
Brand Name	BARTEC	
Model Name	Agile X IS	
Model Difference	N/A	
USB Port:	One provided	
SIM card Port:	One provided	
SD Card Port	One provided	
Gigabit LAN	three provided	
Power Supply	19Vdc from AC/DC adapter or 7.6V battery	
	Battery:	1. Model: IS-E-Bat-Replaceable-V1 2. Model: IS-I-Bat-V1
	Adaptor:	1. Model: EA10633B-190 ; Supplier: EDAC

NFC:

Operating Frequency	13.56MHz
Transmit Power	78.45 dBuV/m Peak at 3m
Number of Channels	1
Antenna Type	Loop Antenna
Module Type	ASK

This report applies for NFC modes.

Remark: The above DUT's information was declared by manufacturer. Please refer to the specifications or user's manual for more detailed description.

1.2 Related Submittal(s) / Grant (s)

This submittal(s) (test report) is intended for FCC ID: **TBUAGXISNFC** filing to comply with Section 15.225 of the FCC Part 15, Subpart C Rules. and IC: **5736C-AGXISNFC** filing to comply with Industry Canada RSS-210 issue 9: 2016 Annex B

1.3 Test Methodology

Both conducted and radiated testing were performed according to the procedures in ANSI C63.10: 2013. and RSS-Gen: 2010. Radiated testing was performed at an antenna to EUT distance 3 meters. Radiated testing was performed at an antenna to EUT distance 3 meters.

1.4 Test Facility

The measurement facilities used to collect the 3m Radiated Emission and AC power line conducted data are located on the address of **International Standards Laboratory** <Lung-Tan LAB> No. 120, Lane 180, Hsin Ho Rd., Lung-Tan Dist., Tao Yuan City 325, Taiwan which are constructed and calibrated to meet the FCC requirements in documents ANSI C63.10: 2013 FCC Registration Number is: TW1036, Canada Registration Number: 4067B-4.

1.5 Special Accessories

Not available for this EUT intended for grant.

1.6 Equipment Modifications

Not available for this EUT intended for grant.

2 System Test Configuration

2.1 EUT Configuration

The EUT configuration for testing is installed on RF field strength measurement to meet the Commissions requirement and operating in a manner which intends to maximize its emission characteristics in a continuous normal application.

2.2 EUT Exercise

The EUT (Transmitter) was tested with a test program to fix the Tx frequency that was for the purpose of the measurements. For more information please see test data and APPENDIX 1 for set-up photographs.

2.3 Test Procedure

2.3.1 Conducted Emissions

The EUT is a placed on as turn table which is 0.8 m above ground plane. According to the requirements in Section 6 of C63.10: 2013. Conducted emissions from the EUT measured in the frequency range between 0.15 MHz and 30MHz using CISPR 16-1-1 Quasi-Peak and Average detector mode.

2.3.2 Radiated Emissions

The EUT is a placed on as turn table which is 0.8/1.5 m above ground plane. The turn table shall rotate 360 degrees to determine the position of maximum emission level. EUT is set 3m away from the receiving antenna which varied from 1m to 4m to find out the highest emission. And also, each emission was to be maximized by changing the polarization of receiving antenna both horizontal and vertical. In order to find out the max. emission, the relative positions of this hand-held transmitter (EUT) was rotated through three orthogonal axes and measurement procedures for electric field radiated emissions above 1 GHz the EUT measurement is to be made “while keeping the antenna in the ‘cone of radiation’ from that area and pointed at the area both in azimuth and elevation, with polarization oriented for maximum response.” Is still within the 3dB illumination BW of the measurement antenna. According to the requirements in Section 8 and 13 and Subclause 8.3.1.2 of ANSI C63.10: 2013.

2.4 Limitation

(1) Conducted Emission

According to §15.207 & RSS-Gen §8.8, frequency range within 150KHz to 30MHz shall not exceed the Limit table as below.

Frequency range MHz	Limits dB (uV)	
	Quasi-peak	Average
0.15 to 0.50	66 to 56	56 to 46
0.50 to 5	56	46
5 to 30	60	50

Note

- 1.The lower limit shall apply at the transition frequencies
- 2.The limit decreases linearly with the logarithm of the frequency in the range 0.15 MHz to 0.50 MHz.

(2) Radiated Emission

1. The field strength of any emission within the band 13.553-13.567 MHz shall not exceed 15,848 microvolts/meter at 30 meters. (124dBuV/m at 3m)
2. Within the bands 13.410-13.553 MHz and 13.567-13.710 MHz, the field strength of any emissions shall not exceed 334 microvolts/meter at 30 meters. (90.47dBuV/m at 3m.)
3. Within the bands 13.110-13.410 MHz and 13.710-14.010 MHz the field strength of any emissions shall not exceed 106 microvolts/meter at 30 meters. (80.5dBuV/m at 3m.)
4. The field strength of any emissions appearing outside of the 13.110-14.010 MHz shall not exceed the general radiated emission limits in section 15.209 and RSS GEN(Intentional Radiators general limit).as below.

Frequency (MHz)	Field strength $\mu\text{V}/\text{m}$	Distance (m)	Field strength at 3m $\text{dB}\mu\text{V}/\text{m}$
1.705-30	30	30	69.54
30-88	100	3	40
88-216	150	3	43.5
216-960	200	3	46
Above 960	500	3	54

- Remark:
1. Emission level in dBuV/m= $20 \log(uV/m)$
 2. Measurement was performed at an antenna to the closed point of EUT distance of meters.
 3. Only spurious frequency is permitted to locate within the Restricted Bands specified in provision of ξ 15.205 and 8.10(RSSGEN)
 4. Emission spurious frequency which appearing within the Restricted Bands specified in provision of ξ 15.205 and 8.10(RSSGEN), then the general radiated emission limits in ξ 15.209 and 8.9(RSSGEN) apply.
 - 5.

Limitation Calculation:

15,848 microvolts/meter at 30 meters = $20\log(15,848)$ dBuV/m at 30m = 84dBuV/m at 30m
= 124dBuV/m at 3m

30m to 3m distance correction factor: $40\log(30/3) = 40\text{dB}$

(3) Frequency Tolerance

The frequency tolerance of the carrier signal shall be maintained within +/- 0.01% of the operating frequency over a temperature variation of -20 degrees to +50 degrees C at normal supply voltage, and for a variation in the primary supply voltage from 85% to 115% of the rated supply voltage at a temperature of 20 degrees C. For battery operated equipment, the equipment tests shall be performed using a new battery.

2.5 Configuration of Tested System

Fig. 2-1 Configuration of Tested System

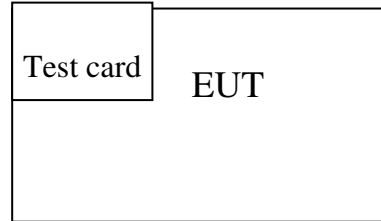

Table 2-1 Equipment Used in Tested System

Item	Equipment	Mfr/Brand	Model/ Type No.	Series No.	Data Cable	Power Cord
1.	Test Card	N/A	N/A	N/A	N/A	N/A

3 Summary of Test Results

FCC and IC Rules	Description Of Test	Result
------------------	---------------------	--------

5 Conducted Emissions Test

5.1 Measurement Procedure:

1. The EUT was placed on a table which is 0.8m above ground plane.
2. Maximum procedure was performed on the six highest emissions to ensure EUT compliance.
3. Repeat above procedures until all frequency measured were complete.

5.2 Test SET-UP (Block Diagram of Configuration)

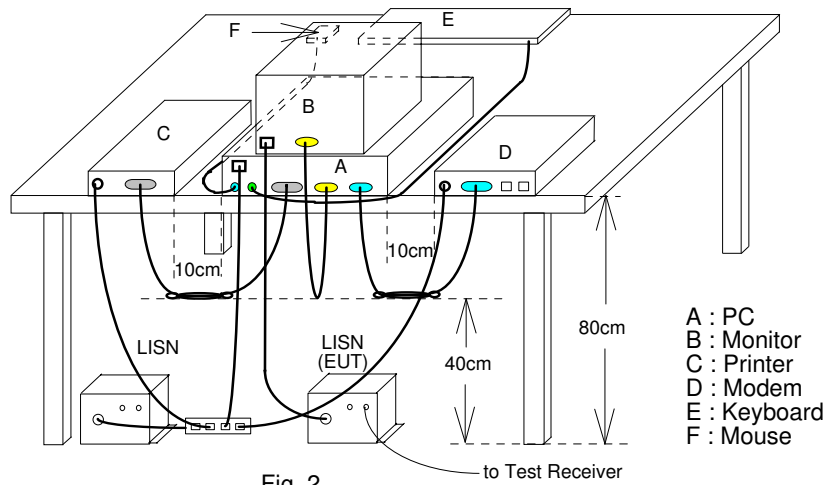

5.3 Measurement Equipment Used:

Conducted Emission Test Site					
EQUIPMENT TYPE	MFR	MODEL NUMBER	SERIAL NUMBER	LAST CAL.	CAL DUE.
Conduction 04-3 Cable	WOKEN	CFD 300-NL	Conduction 04 -3	07/27/2016	07/26/2017
EMI Receiver 17	Rohde & Schwarz	ESCI 7	100887	09/08/2016	09/07/2017
LISN 18	ROHDE & SCHWARZ	ENV216	101424	02/11/2016	02/10/2017
LISN 19	ROHDE & SCHWARZ	ENV216	101425	03/12/2016	03/11/2017
Test Software	Farad	EZEMC Ver:ISL-03A2	N/A	N/A	N/A

5.4 Measurement Result:

The initial step in collecting conducted data is a spectrum analyzer peak scan of the measurement range. Significant peaks are then marked as shown on the following data page, and these signals are then quasi-peaked.

Note: Refer to next page for measurement data and plots.

AC POWER LINE CONDUCTED EMISSION TEST DATA

Operation Mode:	Operation Mode	Test Date:	2016/11/15
Test By:	Lake		

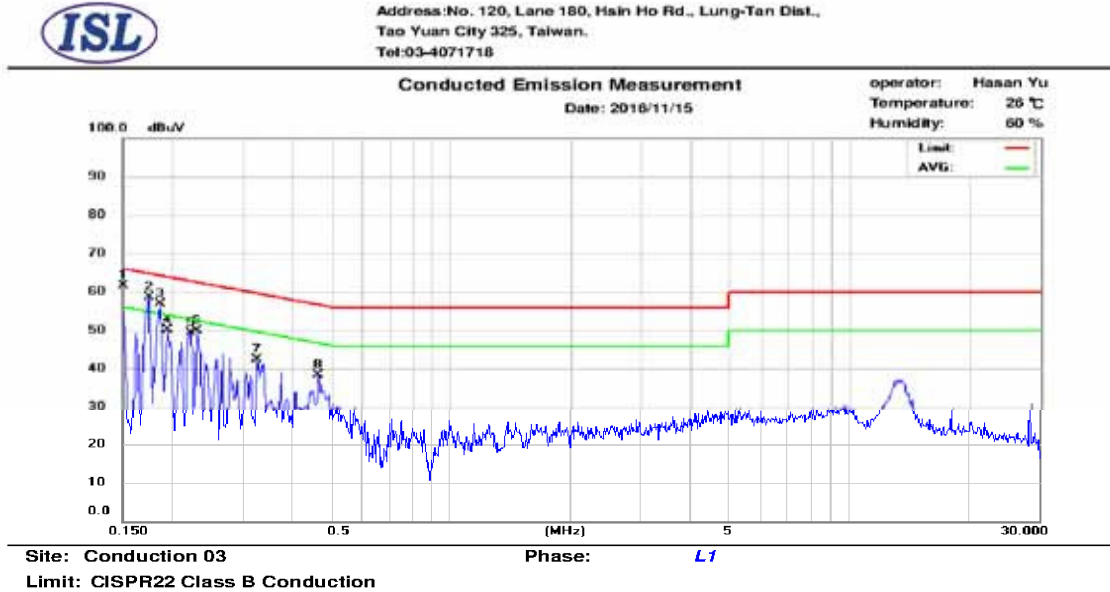

No.	Frequency (MHz)	QP_R (dBuV)	AVG_R (dBuV)	Correct Factor (dB)	QP Emission (dBuV)	QP Limit (dBuV)	QP Margin (dB)	AVG Emission (dBuV)	AVG Limit (dBuV)	AVG Margin (dB)
1	0.150	46.34	27.34	9.77	56.11	66.00	-9.89	37.11	56.00	-18.89
2	0.174	46.54	29.13	9.77	56.31	64.77	-8.46	38.90	54.77	-15.87
3	0.186	44.31	27.64	9.77	54.08	64.21	-10.13	37.41	54.21	-16.80
4	0.194	40.71	22.89	9.77	50.48	63.86	-13.38	32.66	53.86	-21.20
5	0.222	38.31	23.53	9.77	48.08	62.74	-14.66	33.30	52.74	-19.44
6	0.230	36.15	21.60	9.77	45.92	62.45	-16.53	31.37	52.45	-21.08
7	0.326	27.62	16.09	9.78	37.40	59.55	-22.15	25.87	49.55	-23.68
8	0.466	23.74	18.03	9.78	33.52	56.58	-23.06	27.81	46.58	-18.77

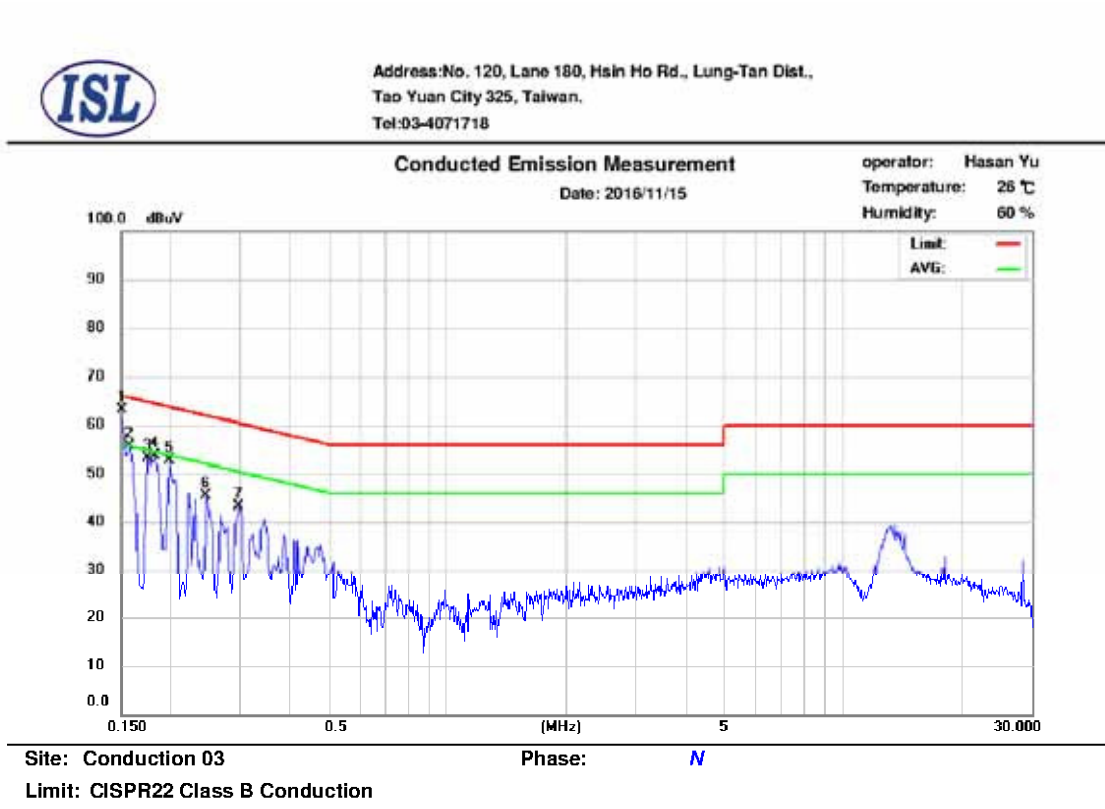

No.	Frequency (MHz)	QP_R (dBuV)	AVG_R (dBuV)	Correct Factor (dB)	QP Emission (dBuV)	QP Limit (dBuV)	QP Margin (dB)	AVG Emission (dBuV)	AVG Limit (dBuV)	AVG Margin (dB)
1	0.150	46.48	27.72	9.74	56.22	66.00	-9.78	37.46	56.00	-18.54
2	0.158	41.12	24.52	9.74	50.86	65.57	-14.71	34.26	55.57	-21.31
3	0.174	46.80	31.20	9.74	56.54	64.77	-8.23	40.94	54.77	-13.83
4	0.182	44.18	28.22	9.75	53.93	64.39	-10.46	37.97	54.39	-16.42
5	0.198	36.09	20.27	9.75	45.84	63.69	-17.85	30.02	53.69	-23.67
6	0.246	30.31	16.50	9.75	40.06	61.89	-21.83	26.25	51.89	-25.64
7	0.298	27.22	14.05	9.75	36.97	60.30	-23.33	23.80	50.30	-26.50

6 Radiated Emission Test

6.1 Measurement Procedure

1. The EUT was placed on a turn table which is 0.8m above ground plane.
2. Maximum procedure was performed on the six highest emissions to ensure EUT compliance.
3. And also, each emission was to be maximized by changing the polarization of receiving antenna both horizontal and vertical.
4. Repeat above procedures until all frequency measured were complete.

6.2 Test SET-UP (Block Diagram of Configuration)

(A) Radiated Emission Test Set-Up, Frequency Below 30MHz

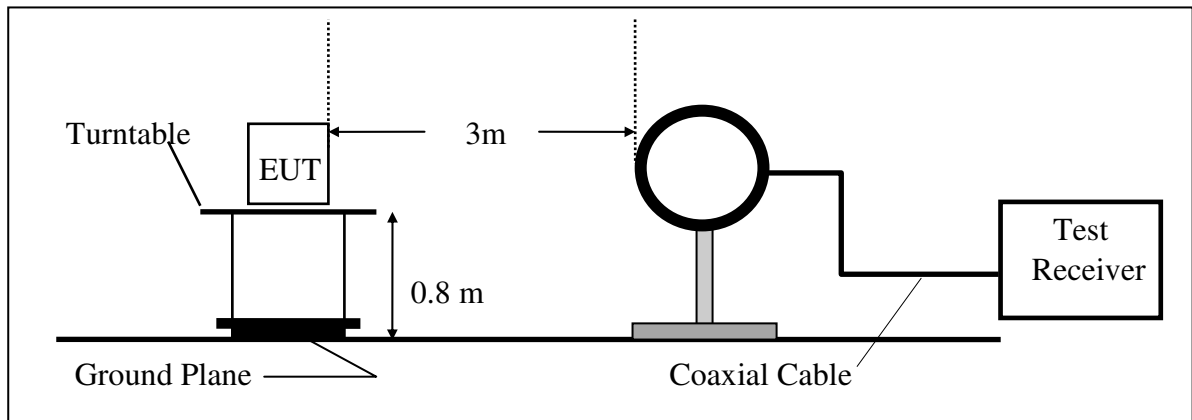

(B) Radiated Emission Test Set-Up, Frequency Below 1000MHz

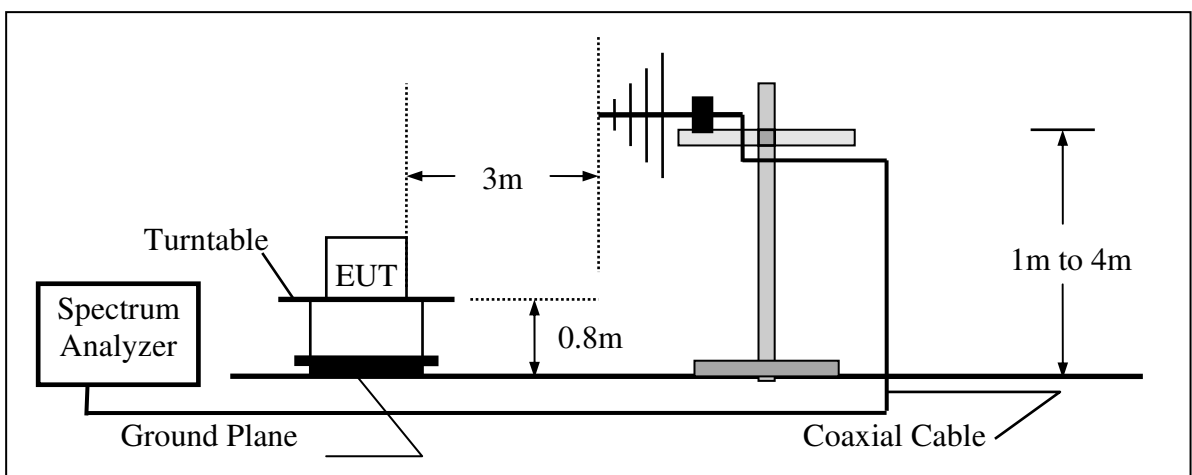

6.3 Measurement Equipment Used:

Chamber 19(966 Chamber)					
EQUIPMENT TYPE	MFR	MODEL NUMBER	SERIAL NUMBER	LAST CAL.	CAL DUE.
966 Chamber	Chance Most	Chamber 19	N/A	08/15/2016	08/14/2017
Spectrum Analyzer 21(3Hz-44GHz)	Agilent	N9030A	MY51360021	10/02/2016	10/01/2017
Loop Antenna (9K-30M)	A.H.SYSTEM	SAS-564	294	06/17/2015	06/16/2017
Bilog Antenna (30M-1G)	SCHWARZBECK	VULB9168 w 5dB Att	736	07/22/2016	07/21/2017
Horn antenna (1G-18G)	SCHWARZBECK	9120D	9120D-1627	07/22/2016	07/21/2017
Horn antenna (18G-26G)	Com-power	AH-826	081001	07/24/2015	07/23/2017
Horn antenna (26G-40G)	Com-power	AH-640	100A	01/21/2015	01/20/2017
Preamplifier (9k-1000M)	HP	8447F	3113A06362	11/13/2016	11/12/2017
Preamplifier(1G-26G)	Agilent	8449B	3008A02471	08/25/2016	08/24/2017
Preamplifier (26G-40G)	EM	EM26G40G	818471	08/23/2015	08/22/2017
RF Cable (9k-18G)	HUBER SUHNER	SUCOFLEX 104A	MY1397/4A	08/25/2016	08/24/2017
RF cable (18G~40G)	HUBER SUHNER	Sucoflex 102	27963/2&37421/2	11/03/2016	11/02/2017
Test Software	Audix	E3 Ver:6.12023	N/A	N/A	N/A

6.4 Field Strength Calculation

The field strength is calculated by adding the Antenna Factor and Cable Factor and subtracting the Amplifier Gain and Duty Cycle Correction Factor (if any) from the measured reading. The basic equation with a sample calculation is as follows:

$$FS = RA + AF + CL - AG$$

Where	FS = Field Strength	CL = Cable Attenuation Factor (Cable Loss)
	RA = Reading Amplitude	AG = Amplifier Gain
	AF = Antenna Factor	

6.5 Measurement Result

Fundamental Measurement Result

Operation Mode : Transmitting Mode
Fundamental Frequency : 13.56 MHz
Temp : 25

Test Date : 2016/11/23
Test By : Lake

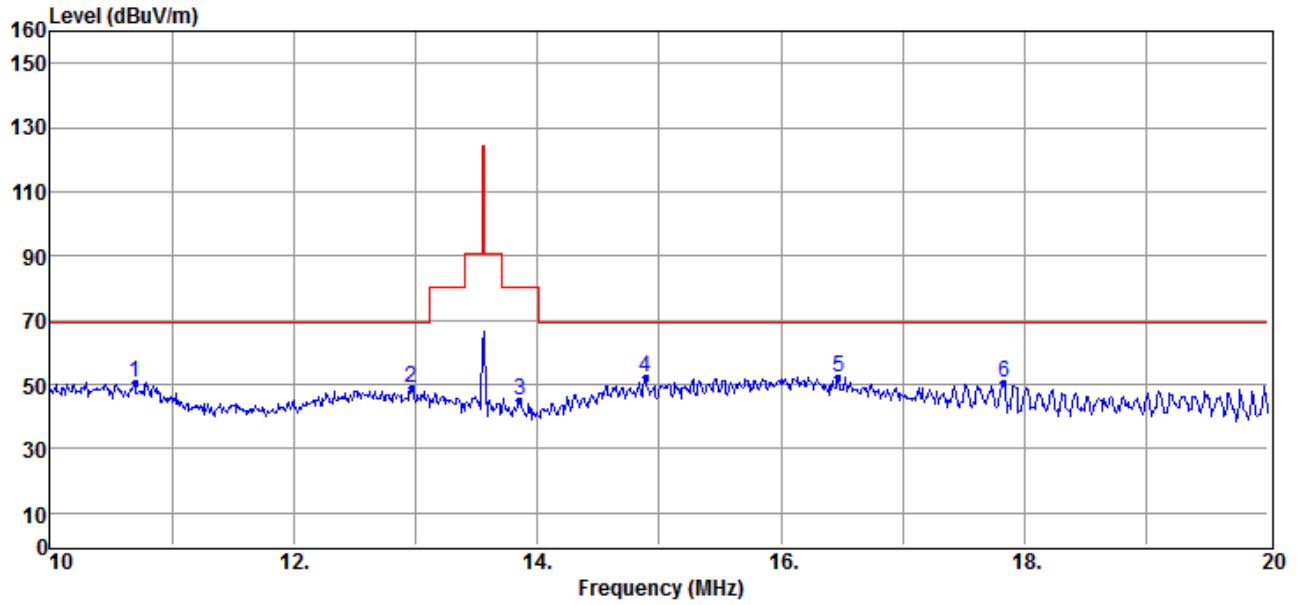

No	Freq MHz	Reading dBuV	Factor dB/m	Level dBuV/m	Limit dBuV/m	Over Limit dB	Remark	Pol V/H
1	10.70	36.01	14.67	50.68	69.54	-18.86	Peak	HORIZONTAL
2	12.97	34.09	14.63	48.72	69.54	-20.82	Peak	HORIZONTAL
3	13.86	30.58	14.62	45.20	80.50	-35.30	Peak	HORIZONTAL
4	14.89	37.84	14.60	52.44	69.54	-17.10	Peak	HORIZONTAL
5	16.47	37.93	14.50	52.43	69.54	-17.11	Peak	HORIZONTAL
6	17.83	36.00	14.41	50.41	69.54	-19.13	Peak	HORIZONTAL



Radiated Spurious Emission Measurement Result (below 1GHz)

Operation Mode:	Transmitting Mode	Test Date:	2016/11/23
Fundamental Frequency:	13.56MHz	Test By:	Lake
Temperature :	25		

7 Frequency Tolerance

7.1 Measurement Procedure

1. The EUT was placed on a turn table which is 0.8m above ground plane.
2. Set EUT as normal operation
3. Set SPA Center Frequency = fundamental frequency, RBW, VBW= 10kHz, Span =100kHz.
4. Set SPA Max hold. Mark peak.
- 5.

7.2 Test SET-UP (Block Diagram of Configuration)

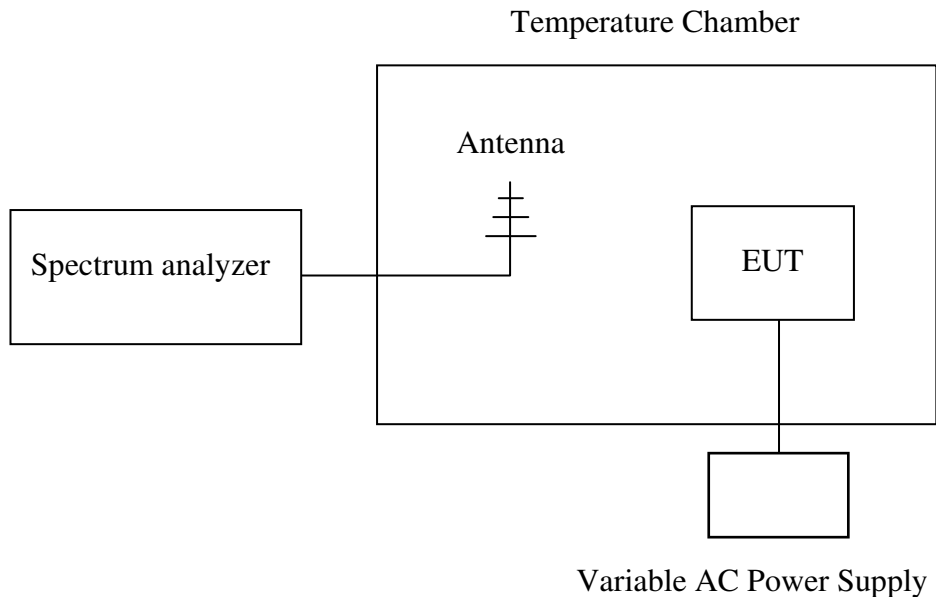

7.3 Measurement Equipment Used:

Conducted Emission Test Site					
EQUIPMENT TYPE	MFR	MODEL NUMBER	SERIAL NUMBER	LAST CAL.	CAL DUE.
Spectrum analyzer	keysight	N9010A	MY56070257	05/31/2016	05/30/2017
Spectrum analyzer	R&S	FSP40	100143	08/07/2016	08/06/2017
Temperature Chamber	KSON	THS-B4H100	2287	06/28/2016	06/27/2017
DC Power supply	ABM	8185D	N/A	09/05/2016	09/04/2017

7.4 Measurement Results

Refer to attached data chart.

A. Temperature Variation

Limit: +/- 0.01%					
Power Supply Vdc	Environment Temperature (Frequency	Delta (KHz)	Limit (KHz)	Result

8 99% Band Width Measurement

8.1 Measurement Procedure

- 1 Place the EUT on the table and set it in transmitting mode.
- 2 Remove the antenna from the EUT and then connect a low loss RF cable from the antenna port to the spectrum analyzer.
- 3 Set the spectrum analyzer as RBW=1% of the approximate emission bandwidth, VBW = 3 times RBW, Span= approximately 20dB below the peak level. Sweep=auto
- 4 Turn on the 99% bandwidth function, max reading.
- 5 Repeat above procedures until all frequency measured were complete.

8.2 Test SET-UP (Block Diagram of Configuration)

Same as 5.2 Radiated Emission Measurement.

8.3 Measurement Equipment Used:

Same as 5.3 Radiated Emission Measurement.

8.4 Measurement Results:

Refer to attached data chart.

99% Band Width test Plot

