

# **GSM/GPRS TRACKING**

**AND ALARM SYSTEM**

**INSTALLATION GUIDED**

**GT-1000**



Introducing the next generation in vehicle security

Extends protection options beyond traditional car alarm

Monitor your vehicle location and status remotely

Communicate with it, be in control



**Connectors detail description**

H1 2\*11 white connector

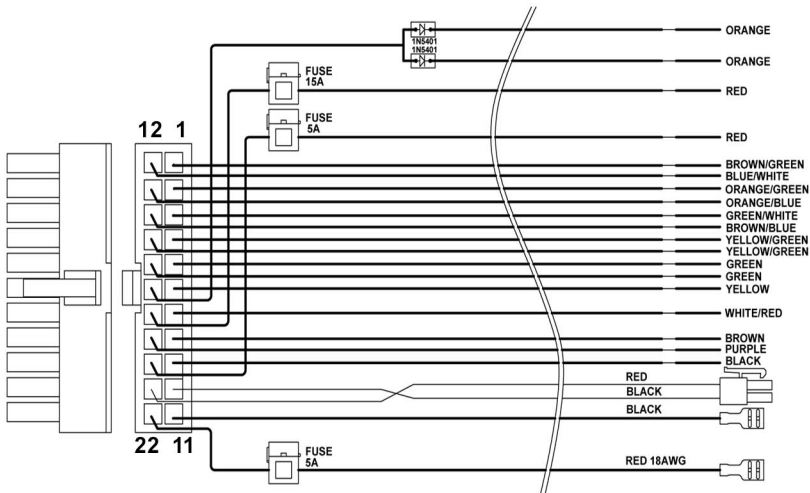

Figure I

H1/1 Brown/Green Wire--- Unlock NO

H1/12, H1/13, H1/14, H1/1, H1/2, H1/3 connect to the central door locking.  
 See Figure II.

H1/2 Orange/green wire...Unlock NC

H1/12, H1/13, H1/14, H1/1, H1/2, H1/3 connect to the central door locking.  
 See Figure II.

H1/3 Green/White Wire ...Unlock COM

H1/12, H1/13, H1/14, H1/1, H1/2, H1/3 connect to the central door locking.  
 See Figure II.

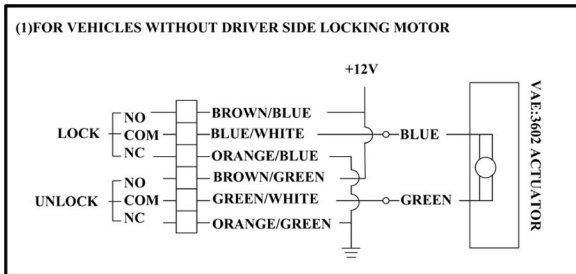

Figure II-A

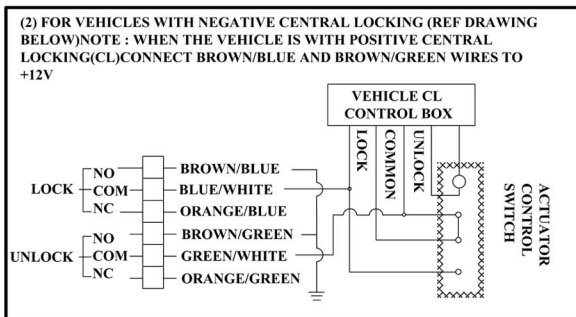

Figure II-B

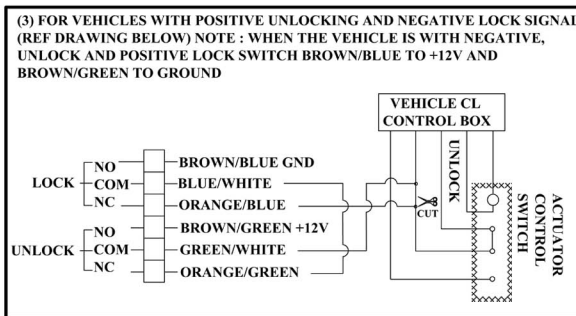

Figure II-C

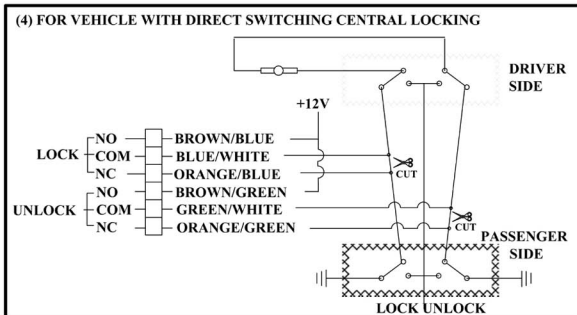

Figure II-D

H1/4&H1/15 Yellow/Green wire —Cut relay NO

These two wires connect to the cut relay NO contact. These two wires have already been connected together on PCB in order to provide enough current to perform immobiliza function. When the system is disarmed and the vehicle ACC is ON, these two wires will connect to the other two cut relay wires (H1/7&H1/18).

H1/5&H1/16 Green wire —Cut relay COM

These two wires connect to the cut relay NO contact. These two wires have already been connected together on PCB in order to provide enough current to perform immobiliza function. When the system is disarmed and the vehicle ACC is ON, these two wires will connect to the other two cut relay wires (H1/8&H1/19).

H1/6 Yellow wire — ACC Sensing Input

This wire should be connected to vehicle ACC. When the vehicle ACC is ON, the wire can sense a high voltage to inform the GT1000 act.

H1/7 white/Red wire--- Siren output

This wire can be connected directly to siren (+) wire, which can provide maximum 1.5A (+) current. This output can be changed to output 300mA(-), if necessary. However, some components on the PCB must be changed accordingly.(Please consult with Portman Electronics technical suport.)

H1/8 Brown wire — Negative Door Switch Sensing Input —

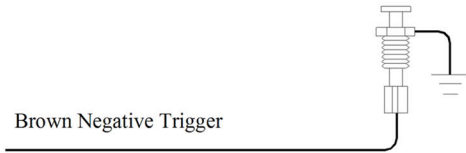

H1/9:Black wire, Ground

The wire connects the system ground. This is main ground connection of GT1000. Make this connection to a solid section of the vehicle frame. Do not connect this wire to any existing ground wires supplied by the factory wire loom, make the connection to the vehicle's frame directly.

H1/10&H1/21

The other terminal of the two wires is a 2PIN connector, it is very convenience to connect the solar battery board. the solar battery board is optional, it means that if there is no solar battery board to connect, GT1000 can still work.

H1/11&H1/22:

The other sides of the two wires have especial terminal that can insert the backup battery terminal directly, the backup battery is necessary, and it can power the GT1000 when the 12V power supply is off.

H1/12 Blue/White wire--- Lock COM

H1/12, H1/13, H1/14, H1/1, H1/2, H1/3 connect to the central door locking. See Figure II.

H1/13 Orange/Blue wire--- Lock NC

H1/12, H1/13, H1/14, H1/1, H1/2, H1/3 connect to the central door locking. See Figure II.

H1/14 Brown/Blue wire--- lock NO

H1/12, H1/13, H1/14, H1/1, H1/2, H1/3 connect to the central door locking. See Figure II.

### H1/17 Orange wire--- (-) parking light output

This wire is divided into two and connected to a 1N5401 diode. Connect these two wires to Left and Right parking light wires. Total output current is 15A (positive).

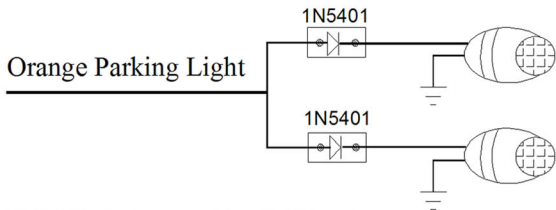

### H1/18 Red wire---parking light input

This wire should be connected to a constant +12 volt source. It offers the power of the parking light.

### H1/19 Purple wire —300mA optional trunk output –

This feature allows you to remote control trunk release. Because the output current is maximum 300mA, it is necessary to connect a relay in order to amplify the drive current.

### H1/20 Red wire--- Red wire – System power (+12V Constant)

The RED wire supplies power to the system. Connect this to a constant +12 volt source.

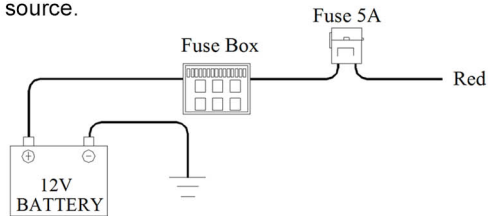

### H2 2 PIN WHITE CONNECTOR FOR TEMPERATRUE SENSOR

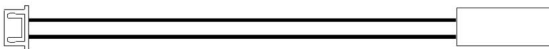

H2/1 Red ---Temperature Sensor +  
H2/2 Black --- Temperature Sensor-

H3 3 PIN RED CONNECTOR FOR EXTERNAL SENSOR

H3/1 white---Sensor trigger Input

H3/2 Black---Ground

H3/3 Red---Power for external sensor

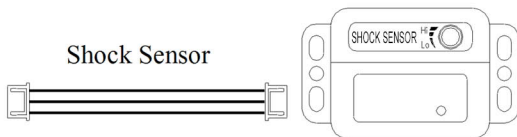

H4 2PIN CONNECTOR FOR GPS CONSTANT OUTPUT(OPTIONAL)

H5 3PIN WHITE CONNECTOR FOR PC SETUP & CAR ALARM

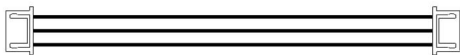

H5/1 Black ---Ground

H5/2 Black ---Transmit DATAS

H5/3 Black --- Receive DATAS

H6 3PIN BLACK CONNECTOR FOR LED & Valet Switch

H6/1 Red ---LED

H6/2 white ---Switch

H6/3 Black --- Ground



## INSTALLATION GUIDE MODE:GT1000

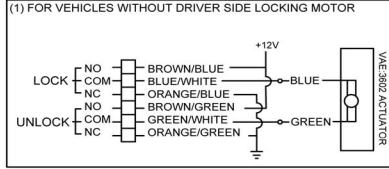

NOTE : WHEN THE VEHICLE IS WITH POSITIVE CENTRAL LOCKING, CONNECT BROWN/BLUE AND BROWN/GREEN WIRES TO +12V

