

FCC Part 2.1091
&
RSS-102, Issue 2

TEST REPORT
RF-Exposure Mobile Device (MPE)
No.: 2-20722858d/07

for

GSM/GPRS Module

MC55i

Applicant: Siemens AG

Laboratory Accreditation and Listings		
 Deutscher Akkreditierungs Rat DAT-P-176/94-02	Federal Communications Commission FCC Registration No. 99538 MRA US-EU DE0003	Industry Canada IC Registration No. IC 3465
accredited according to DIN EN ISO/IEC 17025		

CETECOM GmbH
Laboratory RC & EMC
Im Teelbruch 116
D-45219 Essen
Germany

Telephone: + 49 (0) 20 54 / 95 19-954
Fax: + 49 (0) 20 54 / 95 19-964

Table of contents

1. SUMMARY OF TEST RESULTS	3
1.1. TESTS OVERVIEW	3
2. ADMINISTRATIVE DATA	4
2.1. Identification of the testing laboratory	4
2.2. Test location	4
2.3. Organizational items	4
2.4. Applicant's details	4
2.5. Manufacturer's details	4
3. EQUIPMENT UNDER TEST (EUT)	5
3.1. Additional declaration and description of main EUT	5
3.2. EUT: Type, S/N etc. and short descriptions used in this test report	5
3.3. Auxiliary Equipment (AE): Type, S/N etc. and short descriptions	6
3.4. EUT set-ups	6
3.5. EUT operating modes	7
3.6. Additional declaration and description of EUT's	8
3.7. Configuration of cables used for testing	8
4. MEASUREMENTS SET-UPS	9
4.1. Conducted measurements test set-up	9
4.2. Parameter Settings on mobile phone and base station CMU200	10
5. RADIO FREQUENCY EXPOSURE EVALUATION: MOBILE EQUIPMENT	11
6. MEASUREMENT UNCERTAINTIES	13
7. INSTRUMENTS AND ANCILLARY	14
7.1. Used equipment "CTC"	14
8. PHOTOGRAPHS	18
9. ANNEX 1: DIAGRAMS OF THE MEASUREMENTS	18
10. ANNEX 2: RF-TECHNICAL BRIEF COVER SHEET ACCORDING RSS-102, ISSUE 2.	18

1. Summary of test results

The test results apply exclusively to the test samples as presented in chapter 3.1. The CETECOM GmbH does not assume responsibility for any conclusions and generalisations taken in conjunction with other specimens or samples of the type of the item presented to tests.

The presented GSM 850/900/1800/1900 Module can be build inside host applications and extends their capability by wireless GSM technology. Data transmission or voice application are possible field applications.

In order to verify the compliance, a representative configuration consisting of different auxiliary equipment was chosen. Embedded in this configuration, the GSM/GPRS Module can be tested.

1.1. TESTS OVERVIEW

TEST CASES	PORT	REFERENCES & LIMITS			EUT set-up	EUT operating mode	Result
		FCC Standard	RSS Section	Limits			
TX-Mode							
RF POWER (conducted)	Antenna terminal (conducted)	§2.1046	--	N/A	1	2+4	Passed Remark 1
RADIO FREQUENCY EXPOSURE EVALUATION (MPE)	Cabinet	§1.1310 §2.1091	RSS-102, Issue 2	FCC: §1.1310 Table 1, Limits for General Population IC: Chapter 4.2 RF-Limits	1	2+4	Passed

Remark: 1.) See separate test report B_2_20722858c/07-C1 for measurements according Part 24

ATTESTATION:

I declare that all measurements were performed by me or under my supervision and that all measurements have been performed and are correct to my best knowledge and belief to Industry Canada standards. All requirements as shown in below table are met in accordance with enumerated standards.



 D. Franke
 Responsible for testing laboratory

 GmbH
 Im Teelbruch 116
 45219 Essen
 Tel.: +49 (0) 20 54 7 95 19 - 0
 Fax: +49 (0) 20 54 7 95 19 - 957



 Dipl.-Ing. C. Lorenz..
 Responsible for test report

2. Administrative Data

2.1. Identification of the testing laboratory

Company name:	CETECOM GmbH
Address:	Im Teelbruch 116 45219 Essen – Kettwig, Germany
Laboratory accreditations/Listings:	DAR-Registration No. DAT-P-176/94-02 FCC-Registration No. 99538 MRA US-EU DE0003 IC-Registration No. 3465
Responsible for testing laboratory:	Dipl.-Ing. W. Richter
Deputies:	Dipl.-Ing. H. Strehlow, D. Franke

2.2. Test location

2.2.1. Test laboratory “CTC”

Company name:	see chapter 2.1. Identification of the testing laboratory
---------------	---

2.3. Organizational items

Order No.:	20722858
Responsible for test report and project leader:	Dipl.-Ing. C. Lorenz
Receipt of EUT:	20.11.2007
Date(s) of test:	21.11.2007 – 07.12.2007
Date of report:	03.01.2008
Number of report pages:	19

Version of template:	07.11

2.4. Applicant’s details

Applicant’s name:	Siemens AG
Address:	ICM WM RD ST3 Siemensdamm 50 13623 Berlin Germany
Contact person:	Mr. Thorsten Liebig

2.5. Manufacturer’s details

Manufacturer’s name:	please see Applicant's details
Address:	please see Applicant's details

3. Equipment under test (EUT)

3.1. Additional declaration and description of main EUT

Main function	GSM/GPRS Module		
Type	MC55i		
GSM Frequency range	GSM850: 824 - 849MHz (Uplink), 869 – 894 MHz (Downlink) GSM1900: 1850-1910MHz (Uplink), 1930-1990MHz (Downlink)		
Type of modulation	GMSK		
Number of channels	GSM850: 128 – 251, 125 channels GSM1900: 512 – 810, 300 channels		
EMISSION DESIGNATOR(S)			
Antenna Type	Antenna connector, tested with external standard car magnet antenna		
MAX PEAK Output Power: GSM 850 Radiated	32.02 dBm		
GSM 1900	30.82 dBm		
MAX PEAK Output Power: GSM 850 Conducted	32.57 dBm		
GSM1900	30.11 dBm		
FCC-ID	QIPMC55i		
IC	267W-MC55i		
Installed option	--		
Special EMI components	--		
EUT sample type	<input type="checkbox"/> Production	<input checked="" type="checkbox"/> Pre-Production	<input type="checkbox"/> Engineering

(Applicant's declaration, = not selected, = selected)

3.2. EUT: Type, S/N etc. and short descriptions used in this test report

Short description*)	EUT	Type	S/N serial number	HW hardware status	SW software status
EUT A	GSM/GPRS Module	MC55i	IMEI: 004401080149 475	B2.1	00.303
EUT B	GSM/GPRS Module	MC55i	IMEI: 004401080149 509	B2.1	00.303

*) EUT short description is used to simplify the identification of the EUT in this test report.

3.3. Auxiliary Equipment (AE): Type, S/N etc. and short descriptions

AE short description *)	Auxiliary Equipment	Type	S/N serial number	HW hardware status	SW software status
AE 1	DSB Board	DSB45_B1.1	S30880-Q8301-A1-3 A5B009001034 50-A	B1.1	--
AE 2	DSB Board	DSB45_B1.1	S30880-Q8301-A1-3 A5B009001034 50-B	B1.1	--
AE 3	Handset for Siemens	M20T, MC35T, TC35T, DSB35	017953211304	HH-SI-30.3/V1.1/0--	--
AE 4	GSM Antenna	1140.26-MMCX/m	--	--	--
AE 5	RS 232 cable	--	--	--	--
AE 6	Notebook	Dell D610	EMC #4	--	Windows XP + Terminal Program

*) AE short description is used to simplify the identification of the auxiliary equipment in this test report.

3.4.EUT set-ups

EUT set-up no. *)	Combination of EUT and AE	Remarks
Set. 1	EUT A + AE 1 + AE 3 + (AE 4) + AE 5 + (AE 6)	For conducted tests no AE 4 used

*) EUT set-up no. is used to simplify the identification of the EUT set-up in this test report.

3.5. EUT operating modes

EUT operating mode no. *)	Description of operating modes	Additional information
op. 1	GSM 850 Idle mode BCCH 50	The mobile station is synchronized to the Broadcast Control Channel (BCCH) and listening to the Common Control Channel (CCCH). Periodic location update is disabled.
op. 2	GSM 850 TCH mode	A communication link is established between the mobile station and the test simulator. The transmitter is operated at its maximum rated output power: 33 dBm (power class 4; power control level 5). The input signal to the receiver is modulated with normal test modulation. The wanted RF input signal level to the receiver of the mobile station is set to a level to provide a stable communication link.
op. 3	GSM 1900 Idle mode BCCH 651	The mobile station is synchronized to the Broadcast Control Channel (BCCH) and listening to the Common Control Channel (CCCH).
op. 4	GSM 1900 TCH mode	A communication link is established between the mobile station and the test simulator. The transmitter is operated at its maximum rated output power: 30 dBm (power class 1; power control level 0). The input signal to the receiver is modulated with normal test modulation. The wanted RF input signal level to the receiver of the mobile station is set to a level to provide a stable communication link

*) EUT operating mode no. is used to simplify the test report.

3.6. Additional declaration and description of EUT's

(Applicant's declaration, = not selected, = selected)

AE 1		typical operating cycle. <input checked="" type="checkbox"/> < 0,5 sec. <input type="checkbox"/> :	typical use <input type="checkbox"/> portable use <input checked="" type="checkbox"/> fixed use	<input type="checkbox"/> table-top <input type="checkbox"/> floor-standing <input checked="" type="checkbox"/> not defined
Place of use? <input type="checkbox"/> vehicular use		<input checked="" type="checkbox"/> Residential, commercial and light industry <input type="checkbox"/> Industrial environment		
Power line:		EUT-grounding: (in case of deviation during tests the single details are described on chapter 4)		
<input type="checkbox"/> AC Hz	<input type="checkbox"/> L1, <input type="checkbox"/> L2, <input type="checkbox"/> L3, <input type="checkbox"/> N <input type="checkbox"/> 12V, <input type="checkbox"/> 24V, <input type="checkbox"/> 230V, <input type="checkbox"/> 400V	<input checked="" type="checkbox"/> none <input type="checkbox"/> with power supply <input type="checkbox"/> additional:		
<input checked="" type="checkbox"/> DC	<input checked="" type="checkbox"/> 9 V DC			
Other Ports	possible total cable length	shielding	connected during test	
1. DC Power port	<input checked="" type="checkbox"/> > 1m <input type="checkbox"/> > 2m <input type="checkbox"/> > 3m <input type="checkbox"/> :	<input type="checkbox"/> screened <input checked="" type="checkbox"/> unscreened	<input checked="" type="checkbox"/> yes <input type="checkbox"/> no	
2. Handset port (audio)	<input type="checkbox"/> > 1m <input checked="" type="checkbox"/> > 2m <input type="checkbox"/> > 3m <input type="checkbox"/> :	<input type="checkbox"/> screened <input checked="" type="checkbox"/> unscreened	<input checked="" type="checkbox"/> yes <input type="checkbox"/> no	
3. RF antenna port	<input type="checkbox"/> > 1m <input checked="" type="checkbox"/> > 2m <input type="checkbox"/> > 3m <input type="checkbox"/> :	<input checked="" type="checkbox"/> screened <input type="checkbox"/> unscreened	<input checked="" type="checkbox"/> yes <input type="checkbox"/> no	
4. RS 232 port (COM1) (COM2-not used)	<input checked="" type="checkbox"/> > 1m <input type="checkbox"/> > 2m <input type="checkbox"/> > 3m <input type="checkbox"/> :	<input type="checkbox"/> screened <input checked="" type="checkbox"/> unscreened	<input checked="" type="checkbox"/> yes <input type="checkbox"/> no	
Does EUT contain devices susceptible to magnetic fields, e.g. Hall elements, electrodynamics microphones, etc.?			<input type="checkbox"/> yes <input checked="" type="checkbox"/> no	
Is mounting position / usual operating position defined?			<input type="checkbox"/> yes <input checked="" type="checkbox"/> no	

3.7. Configuration of cables used for testing

Following cables were connected to the DSB board according manufacturers information: DC-power supply cable, Audio cable and RF cable.

4. Measurements Set-ups

4.1. Conducted measurements test set-up

The EUT's RF-signal is coupled out by a suitable antenna coupling connector (1). The signal is first 10 dB attenuated (2) before it is 0° divided by a power divider (3). One of the signal path is connected to the communication base station (4), other branch is connected to the spectrum – analyzer (5). The specific attenuation losses for both signal paths/branches are determined prior to the measurement within a set-up calibration. These are then taken into account by correcting the measurement readings on the spectrum-analyzer.

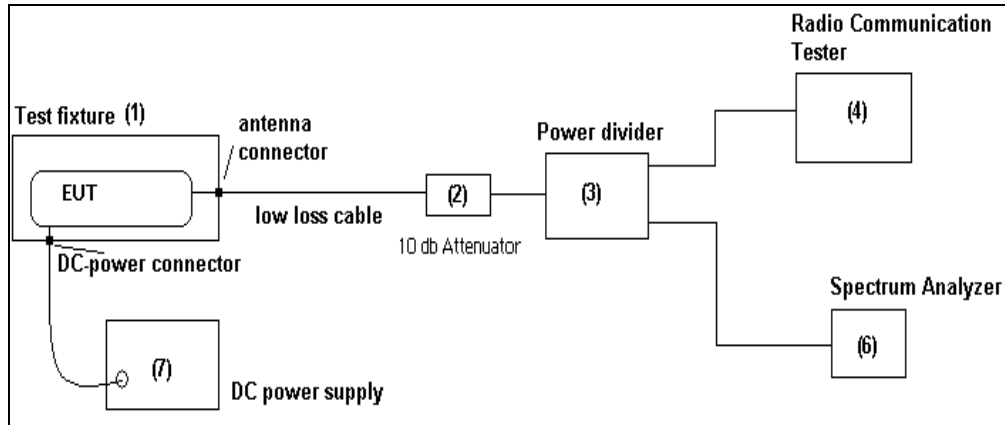

Schematic: Test set-up conducted

4.2. Parameter Settings on mobile phone and base station CMU200

Settings for CMU (general)

Parameter	Traffic Mode	Idle Mode
Traffic Channels mobile station	GSM 850: TCH _{MS} = 128/192/251 GSM 1900 TCH _{MS} = 512/681/810	--
maximum power step (PCL)	GSM 850: PCL = 5 (2 Watt) GSM 1900: PCL = 0 (1 Watt)	--
Modulation	GSM: GMSK-Modulation Scheme	--
DTX	off	--
Bitstream	PRBS 2E9-1 (pseudo-random-sequence) – CCITT 0.153	
Timeslot	3	
Hopping	off	
Timeslot (slot mode)	single	
Maximum data transmission rate, single time slot	GSM: 17,6 kBit/s Slot	
Speech transcoding (Traffic Mode)	Full rate Version 1	
Mode	BCCH and TCH	
BCCH – base station (CMU,CMD)	Channel 182 for GSM 850 Channel 651 for GSM1900	182 651
TCH – base station (CMD, CMU)	auto	
Power level TCH – base station (used timeslot level)	- 70 dBm	
Power level BCCH – base station (control channel level)	- 80 dBm	
External attenuation RF/AF-Input/Output	Accord. calibration prior to measurements	
P/PCL	3 channels	
BS_AG_BLKS_RES	Not applicable	0
Paging reorganisation		Off (0)
Signalling channel		SDCCH
Location Update		Auto
Cell access		Disabled (barred)

Additional settings on the base stations CMU200 for frequency stability measurements

Repetition	Continuous	
Stop condition	None	
Display mode	Max./Min	
Statistic Count	1000 Bursts	
Decoder	Standard	

5. Radio Frequency Exposure Evaluation: Mobile Equipment

REFERENCES

FCC: §1.1310, § 2.1091
 IC: RSS-102, Issue 2, Nov. 2005

The criteria used for the evaluation of human exposure to radio frequency radiation is table 1 according FCC §1.1310/ RSS-102, Table, Chapter 4.2.

As the mobile equipment is authorized under Part 22 (Subpart H)/ RSS132, Issue 2 and Part 24/ RSS133, Issue 3 of the FCC/IC Rules, and it is subject for evaluation of the RF exposure prior to equipment authorization.

§2.1091: Further information on evaluating compliance with these limits can be found in the FCC’s OST/OET Bulletin Number 65, “Evaluating Compliance with FCC-Specified Guidelines for Human Exposure to Radiofrequency Radiation.”

RSS-102: Health Canada Safety code 6: Limits of Human Exposure to Radiofrequency Electromagnetic Fields in the Frequency Range from 3kHz to 300GHz.

For purposes of these requirements mobile devices are defined by the FCC as transmitters designed to be used in other than fixed locations and to generally be used in such a way that a separation distance of at least 20 centimeters is normally maintained between radiating structures and the body of the user or nearby persons. These devices are normally evaluated for exposure potential with relation to the MPE limits given in Table 1 of Appendix A.

TABLE 1—LIMITS FOR MAXIMUM PERMISSIBLE EXPOSURE (MPE)—Continued

Frequency range (MHz)	Electric field strength (V/m)	Magnetic field strength (A/m)	Power density (mW/cm ²)	Averaging time (minutes)
30–300	61.4	0.163	1.0	6
300–1500	f/300	6
1500–100,000	5	6
(B) Limits for General Population/Uncontrolled Exposure				
0.3–1.34	614	1.63	*(100)	30
1.34–30	824/f	2.19/f	*(180/f ²)	30
30–300	27.5	0.073	0.2	30
300–1500	f/1500	30
1500–100,000	1.0	30

f = frequency in MHz

Table 1: FCC LIMITS FOR MAXIMUM PERMISSIBLE EXPOSURE (MPE)

The used equation to predict the power density in the far-field of one single radiating antenna can be made by following equation:

$$S = \frac{EIRP}{4\pi R^2} = \frac{P * G}{4\pi R^2}$$

Abbreviations:

- S: Power density (unit: mW/cm²)
- P: Power Input to the antenna
- G: Gain of the antenna relative to an isotropic radiator, for further calculation assumed to be 0 dBi (Gain numeric=1)
- EIRP: Equivalent isotropically radiated power, determined within a separate measurement (unit: mW)

For given Power Density limit at a single frequency (accord. Table 1) the maximum antenna gain can be calculated:

$$G_{NUMERIC} = \frac{S * 4\pi R^2}{P}$$

METHOD:

The RF-exposure values were derived from the measured conducted Peak Power with assumed antenna gain of 0dBi.

The power was checked on 3 frequencies (lowest/middle/highest) within each operable GSM-band. Please refer to chapter 4.1 for the measurement set-up.

Please find enclosed the calculation of each limit and the graphical representation for the frequency range 100 MHz to 2.5 GHz. Also the maximum admissible allowed antenna gain is calculated.

RESULTS:

Band	Channel no.	Channel Frequency	Power-Value		MPE-Value	FCC MPE-Limit	Margin to limit	Maximum admissible Antenna gain at 20 cm distance (Unit: dBi)
			Unit: dBm	Unit: mWatt	Unit: mWatt/cm ²			
GSM 850	128	824,2	32,32	1706,08	0,3394	0,5495	0,2100	2,0920
	192	837	32,46	1761,97	0,3505	0,5580	0,2075	2,0189
	251	848,8	32,57	1807,17	0,3595	0,5659	0,2063	1,9697
GSM 1900	512	1850,2	30,11	1025,65	0,2041	1,0000	0,7959	6,9026
	661	1880	29,88	972,74	0,1935	1,0000	0,8065	7,1326
	810	1808,8	29,82	959,40	0,1909	1,0000	0,8091	7,1926

Remark: conducted power values can be found in test report B_2_20722858c/07-C1

RSS-102 standard requires the RF-exposure value in W/m² unit; therefore the value determined in mW/cm² unit should be multiplied by 10 to have the required unit.

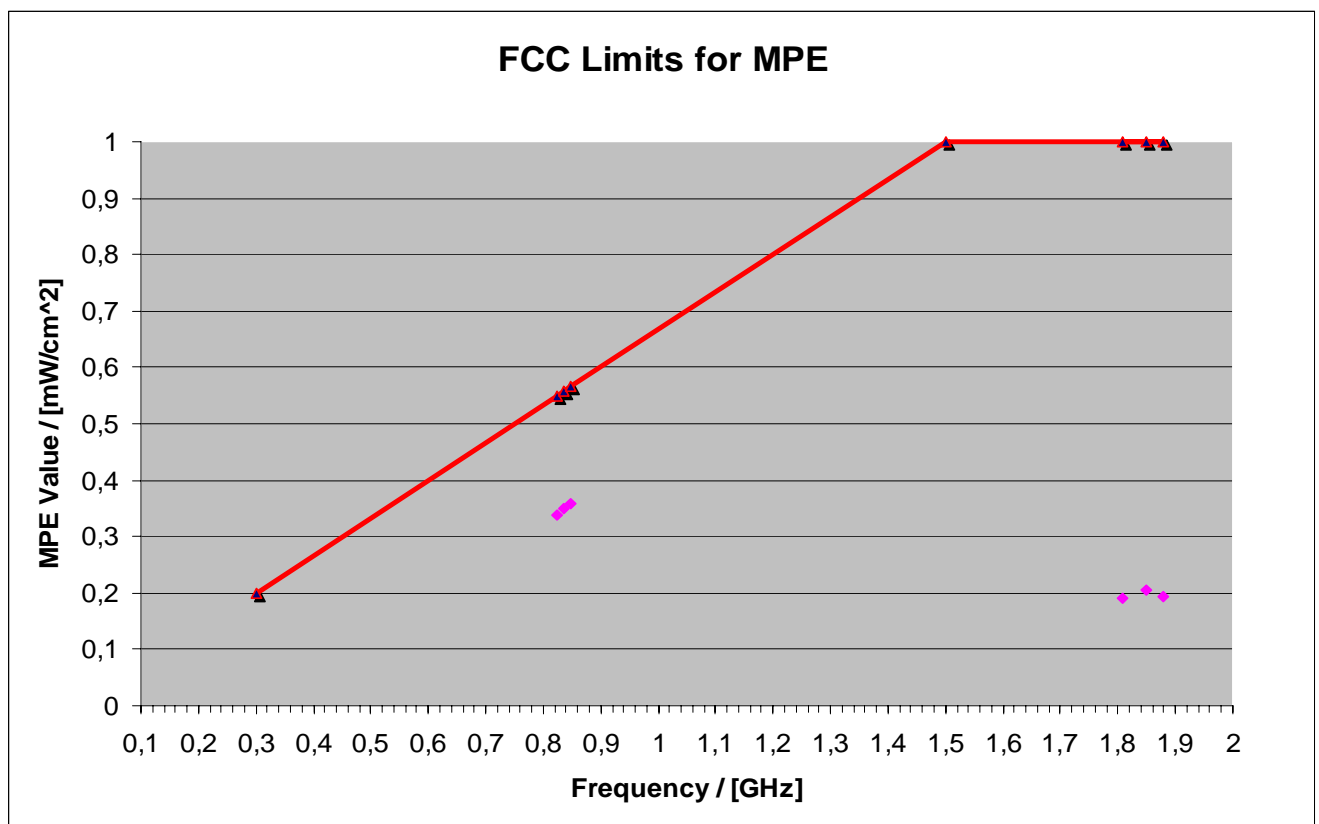

6. Measurement uncertainties

The reported uncertainties are calculated based on the standard uncertainty multiplied with the appropriate coverage factor **k**, such that a confidence level of approximately 95% is achieved.

For uncertainty determination, each component used in the concrete measurement set-up was taken in account and it's contribution to the overall uncertainty according it's statistical distribution calculated.

Following table shows expectable uncertainties for each measurement type performed.

Measurement	Frequency range	Calculated uncertainty based on a confidence level of 95%	Remarks:
RF-Power Output conducted	9 kHz .. 20 GHz	1 dB	--
RF-Power Output radiated	30 MHz .. 4 GHz	3,17 dB	Substitution method
Conducted RF-emissions on antenna ports	9 kHz .. 20 GHz	1 dB	--
Radiated RF-emissions enclosure	150 kHz .. 30 MHz	5 dB	Magnetic field
	30 MHz .. 1 GHz	4,2 dB	E-Field
	1GHz .. 19 GHz	3.17 dB	Substitution method
Occupied bandwidth	9 kHz .. 4 GHz	0,1272 ppm (Delta Marker method)	Frequency error
		1 dB	Power
Emission bandwidth	9 kHz .. 4 GHz	0,1272 ppm (Delta Marker method)	Frequency error
		1 dB	Power
Frequency stability	9 kHz .. 20 GHz	0,0636 ppm	--
Conducted emission on AC-mains port (U _{CISPR})	9 kHz .. 150 kHz	4 dB	--
	150 kHz .. 30 MHz	3.6 dB	

Table : measurement uncertainties valid for conducted/radiated measurements

7. Instruments and Ancillary

7.1. Used equipment "CTC"

The "Ref.-No" in the left column of the following tables allows the clear identification of the laboratory equipment.

7.1.1. Test software and firmware of equipment

Ref.-No.	Equipment	Type	Serial-No.	Version of Firmware or Software during the test
001	emi test receiver	ESS	825132/017	Firm = 1.16 , OTP=2.0, GRA=2.0
012	signal generator (EMS-cond.)	SMY 01	839069/027	Firm.= V 2.02
013	power meter (EMS cond.)	NRVD	839111/003	Firm.= V 1.51
017	Communication Tester	CMD 60 M	844365/014	Firmware = V 3.52 .22.01.99, DECT Firmware D2.87
053	audio analyzer	UPA3	861215/015	Firm. V 4.3
119	RT harmonics analyser/dig. flickermeter	B10	G60547	Firm.= V 3.1DHG
120	spectrum analyzer	FSEM 30	845538/011	Bios=2.1, Analyzer-Firmware= 3.30.3
138	spectrum analyzer, display unit	FSA-D	863619/003	Firm.= 2.90
139	spectrum analyzer, RF unit	FSBS-RF	863373/003	Firm.= 2.90
140	signal generator	SMHU	831314/006	Firm.= 3.21
261	thermal power sensor	NRV-Z55	825083/0008	EPROM-Datum 02.12.04, SE EE 1 B
262	power meter	NRV-S	825770/0010	Firm = 2.6
263	signal generator	SMP 04	826190/0007	Firm.=3.21
264	spectrum analyzer	FSEK 30	826939/005	Bios=2.1, Analyzer= 3.20
277	Vector-Networkanalyzer	ZVC	831363/0005	Bios= 3.3, Analyzer=3.52
295	Racal Digital Radio Test Set	6103	1572	UNIT Firmware= 4.04, SW-Main=4.04, SW-BBP=1.04,
298	Radio Communication Tester	CMU 200	832221/091	R&S Test Firmware =3.53 /3.54 (current Testsoftw. f.
323	Communication Tester	CMD 55	825878/034	Firm.= 3.52 .22.01.99
331	climatic test chamber -40/+80 Grad	HC 4055	43146	TSI 1.53
335	System-CTC-EMS-Conducted	System EMS Conducted	-	EMS-K1 Immunity Test-Software 1.20SR10
340	Communication Tester	CMD 55	849709/037	Firm = 3.52 .22.01.99
355	power meter	URV 5	891310/027	Firm = 1.31
366	Ultra Compact Simulator	UCS 500 M4	V0531100594	001925 / 3.06a02
377	emi test receiver	ESCS 30	100160	Firm = 2.29, OTP= 02.01, GRA= 02.36
378	broadband RF field monitor	RadiSense III	03D00013SNO-08	Firm = V.03D13
383	signal generator	SME 03	842 828 /034	Firm = 4.61
389	digital multimeter	Keithley 2000	0583926	Firm. = A13 (Mainboard) A02 (Display)
392	Radio Communication Tester	MT8820A	6K00000788	Firm = 4.50 #005, IPL=4.01#001,OS=4.02#001,
420	System CTC CTIA-OTA	System CTC CTIA-OTA	-	EMQuest EMQ-100 Ver. 1.05
436	Radio Communication Tester	CMU 200	103083	R&S Test Firmware =4.30 (current Testsoftw. f. all band
441	System CTC-SAR-EMI	System EMI field (SAR)	-	EMC 32 Version 6.10 .3, ESXS-K1 Version 2.20
442	System CTC-SAR-EMS	System EMS field (SAR)	-	EMS-K1 Immunity-Software 1.20SR10
443	System CTC-FAR-EMI-Spuri	System CTC-FAR-EMI-	-	Spuri 6.4a und Spuri 7.0
444	System CTC FAR-EMS	System EMS-Field (FAR)	-	EMS-K1 Immunity-Software 1.20SR10
460	Radio Communication Tester	CMU 200	108901	R&S Test Firmware Base=4.51/Messsoftware=4.50
489	emi test receiver	ESU40	1000-30	Firmware=3.93, Bios=V5.1-16-3, Specification=01.00
491	ESD Simulator dito	ESD dito	dito307022	V 2.30
524	Voltage Drop Simulator	VDS 200	0196-16	Software Nr: 000037 Version V4.20a01
526	Burst Generator	EFT 200 A	0496-06	Software Nr. 000034 Version V2.32
527	Micro Pulse Generator	MPG 200 B	0496-05	Software-Nr = 00030 Version V2.43
528	Load Dump Simulator	LD 200B	0496-06	Software-Nr. 000031 Version V2.35a01

7.1.2. Single instruments and test systems

Ref.-No.	Equipment	Type	Serial-No.	Manufacturer	Interval of calibration	Remark	Cal due
001	emi test receiver	ESS	825132/017	Rohde & Schwarz	12 M	-	31.03.2008
005	AC - LISN (50 Ohm/50µH, test site 1)	ESH2-Z5	861741/005	Rohde & Schwarz	12 M	-	31.03.2008
007	DC - LISN (50 Ohm/5µH)	ESH3-Z6	892563/002	Rohde & Schwarz	12 M	-	31.03.2008
009	power meter (EMS-radiated)	NRV	863056/017	Rohde & Schwarz	12 M	-	31.03.2008
012	signal generator (EMS-cond.)	SMY 01	839069/027	Rohde & Schwarz	36 M	-	31.03.2008
013	power meter (EMS cond.)	NRVD	839111/003	Rohde & Schwarz	12 M	-	31.03.2008
014	insertion unit (EMS cond.)	URV5-Z2	838519/029	Rohde & Schwarz	12 M	-	31.03.2008
015	insertion unit (EMS cond.)	URV5-Z4	838570/024	Rohde & Schwarz	12 M	-	31.03.2008
016	line impedance simulating network	Op. 24-D	B6366	Spitzenberger + Spies	36 M	-	31.10.2010
017	Communication Tester	CMD 60 M	844365/014	Rohde & Schwarz	12 M	-	31.03.2008
020	horn antenna 18 GHz (Subst 1)	3115	9107-3699	EMCO	36 M	-	31.03.2010
021	loop antenna (H-Field)	6502	9206-2770	EMCO	36 M	-	31.03.2010
022	audio measurement amplifier	2636C	1537643	Brüel & Kjaer	12 M	-	31.03.2008
024	band pass filter 1 kHz	1625	1814825	Brüel & Kjaer	24 M	2	31.03.2008
030	loop antenna (H-field)	HFH-Z2	879604/026	Rohde & Schwarz	36 M	-	31.03.2009
031	absorbing clamp	MDS-21	863325/015	Rohde & Schwarz	24 M	-	31.03.2009
033	RF-current probe (100kHz-30MHz)	ESH2-Z1	879581/18	Rohde & Schwarz	12 M	-	31.03.2008
034	ESD - generator	ESD 30	ESD 30.0689-04	EM TEST	12 M	-	31.03.2008

Ref.-No.	Equipment	Type	Serial-No.	Manufacturer	Interval of calibration	Remark	Cal due
035	air discharge module	P 18	P 18-0689-04	EM TEST	12 M	-	31.03.2008
036	contact discharge module	P 18	P 18-0392-55	EM TEST	12 M	-	31.03.2008
048	bicon. - log. antenna (SAR)	3143	1108	EMCO	36 M	-	31.10.2008
049	current clamp (injection)	F-120-2	48	FCC	12 M	-	31.03.2008
050	3-ph coupling-decoupling-netw. (Burst)	CDN 300	176	Schaffner	12 M	-	31.03.2008
051	VHF-current probe 20-300 MHz	ESV-Z1	872421	Rohde & Schwarz	12 M	-	31.03.2008
052	notch filter DECT	WRCB 1887,82/1889,55SS	12	Wainwright Industries	12 M	-	31.03.2008
053	audio analyzer	UPA3	861215/015	Rohde & Schwarz	36 M	-	31.03.2008
057	relay-switch-unit (EMS system)	RSU	494440/002	Rohde & Schwarz	-	1a	30.04.2008
058	capacitive clamp (Burst)	IP 4	99	Hafely	-	4	
059	ferrite tube	FGZ 40 X 15 E	4225	Lüthi	36 M	-	31.03.2010
060	power amplifier (DC-2kHz)	PAS 5000	B6363	Spitzenberger + Spies	-	3	
061	ferrite tube	FGZ 40 X 15 E	4250	Lüthi	36 M	-	31.03.2010
063	log.-per. antenna (Subst 1)	3146	860941/007	EMCO	36 M	-	31.10.2010
065	attenuator, (6 dB) 50 Ohm, 250W	AT 50-6-250	521057	BNOS Electronics	12 M	1b	30.04.2008
066	notch filter (WCDMA; FDD1)	WRCT 1900/2200-5/40-	5	Wainwright Instr. GmbH	12 M	-	31.03.2008
067	coupling decoupling-network	CDN801-M2/M3	272	Lüthi	12 M	-	31.03.2008
068	coupling decoupling-network	CDN 801-M5	95226	Lüthi	12 M	-	31.03.2008
069	EM - clamp	EM101	9535159	Lüthi	24 M	-	31.03.2008
070	ferrite tube	FTC101	4199	Lüthi	24 M	-	31.03.2008
071	biconical antenna (Subst 1)	HUF-Z2	863.029/010	Rohde & Schwarz	36 M	-	31.10.2010
072	coupling decoupling-network	CDN801-M2/M3	276	Lüthi	12 M	-	31.03.2008
079	4 wire T-network	EZ-10	862.939 / 011	Rohde & Schwarz	24 M	-	31.03.2009
083	AC - power supply, 0-10 A	EAC/MT 27010	910502096	EURO TEST	pre-m	2	
084	AC - power supply, 0-5 A	ELABO-8-34214	-	ELABO	pre-m	2	
085	AC - power supply, 0-10 A	R250	-	Schunterm.&Benningh.	pre-m	2	
086	DC - power supply, 0 -10 A	LNG 50-10	-	Heinzinger Electronic	pre-m	2	
087	DC - power supply, 0 -5 A	EA-3013 S	-	Elektro Automatik	pre-m	2	
090	Helmholtz coil: 2x10 coils in series	-	-	RWTÜV	pre-m	4	
091	USB-LWL-Converter	OLS-1	007/2006	Ingenieurbüro Scheiba	-	4	
094	artificial head (No.1)	4905	1566990	Brüel & Kjaer	pre-m	2	
095	band pass filter 1 kHz	MS 210R/T2.	2108400	IMD GmbH	24 M	2	31.03.2008
099	passive voltage probe	ESH2-Z3	299.7810.52	Rohde & Schwarz	12 M	-	31.03.2008
100	passive voltage probe	Probe TK 9416	without	Schwarzbeck	12 M	-	31.03.2008
110	USB-LWL-Converter	OLS-1	-	Extreme USB	-	4	
119	RT harmonics analyser/dig. flickermeter	B10	G60547	BOCONSULT	36 M	-	31.03.2010
120	spectrum analyzer	FSEM 30	845538/011	Rohde & Schwarz	12 M	-	31.03.2008
121	notch filter GSM 1900	WRCB 1879,5/1880,5EE	15	Wainwright Industries.	12 M	-	31.03.2008
122	notch filter GSM 1800	WRCB 1747/1748	12	Wainwright Industries	12 M	-	31.03.2008
123	biconical antenna (Subst 2)	HUF-Z2.	860941/007	Rohde & Schwarz	36 M	-	31.03.2010
131	RF-Current Probe	F-52	19	FCC	12 M	-	31.03.2008
132	log.-per. antenna (Subst 2)	HUF-Z3	860862/014	Rohde & Schwarz	36 M	-	31.03.2010
133	horn antenna 18 GHz (Meas 1)	3115	9012-3629	EMCO	36 M	-	31.03.2010
134	horn antenna 18 GHz (Subst 2)	3115	9005-3414	EMCO	12 M	-	31.03.2008
136	adjustable dipole antenna (Dipole 1)	3121C-DB4	9105-0697	EMCO	12 M	-	31.03.2008
137	1000 Hz calibrator 94 dB SPL	4230 94 dB	1 594 698	Brüel & Kjaer	12 M	-	31.03.2008
138	spectrum analyzer, display unit	FSA-D	863619/003	Rohde & Schwarz	12 M	-	31.03.2008
139	spectrum analyzer, RF unit	FSBS-RF	863373/003	Rohde & Schwarz	12 M	-	31.03.2008
140	signal generator	SMHU	831314/006	Rohde & Schwarz	24 M	-	31.03.2008
142	attenuator (6 dB) 2 W, 8 GHz	DGL N	-	Radiall	12 M	1b	30.04.2008
248	attenuator	SMA 6dB 2W	-	Radiall	pre-m	2	
249	attenuator	SMA 10dB 10W	-	Radiall	pre-m	2	
252	attenuator	N 6dB 12W	-	Radiall	pre-m	2	
254	high pass GSM1800/1900/DECT	5HC 2600/12750-1.5KK	23042	Trilithic	12 M	-	31.03.2008
256	attenuator	SMA 3dB 2W	-	Radiall	pre-m	2	
257	hybrid	4031C	04491	Narda	pre-m	2	
260	hybrid coupler	4032C	11342	Narda	pre-m	2	
261	thermal power sensor	NRV-Z55	825083/0008	Rohde & Schwarz	24 M	-	31.03.2008
262	power meter	NRV-S	825770/0010	Rohde & Schwarz	24 M	-	31.03.2008
263	signal generator	SMP 04	826190/0007	Rohde & Schwarz	24 M	-	31.03.2009
264	spectrum analyzer	FSEK 30	826939/005	Rohde & Schwarz	12 M	-	31.03.2008
265	peak power sensor	NRV-Z33, Model 04	840414/009	Rohde & Schwarz	24 M	-	31.03.2008
266	peak power sensor	NRV-Z31, Model 04	843383/016	Rohde & Schwarz	24 M	-	31.03.2008
267	notch filter GSM 850	WRCA 800/960-6EEK	9	Wainwright Industries	12 M	-	31.03.2008
268	AC/DC power supply	EA 3050-A	9823636	pre-m	2		
270	termination	1418 N	BB6935	Weinschel	pre-m	2	
271	termination	1418 N	BE6384	Weinschel	pre-m	2	
272	attenuator (20 dB) 50 W	Model 47	BF6239	Weinschel	pre-m	2	
273	attenuator, (10 dB) 100 W	Model 48	BF9229	Weinschel	pre-m	2	
274	attenuator (10 dB) 50 W	Model 47 (10 dB) 50 W	BG0321	Weinschel	pre-m	2	
275	DC-Block	Model 7003 (N)	C5129	Weinschel	pre-m	2	
276	DC-Block	Model 7006 (SMA)	C7061	Weinschel	pre-m	2	
277	Vector-Networkanalyzer	ZVC	831363/0005	Rohde & Schwarz	12 M	-	31.03.2008
279	power divider	1515 (SMA)	LH855	Weinschel	pre-m	2	
284	coupling decoupling network	CDN 801-M1	1661	Lüthi	12 M	-	31.03.2008
285	coupling decoupling network	CDN 801-S1	1642	Lüthi	12 M	-	31.03.2008
287	pre-amplifier 25MHz - 4GHz	AMF-2D-100M4G-35-10P	379418	Miteq	12 M	-	31.03.2008
289	bicon. - log. antenna (OATS)	CBL 6141	4107	Schaffner Chase	36 M	-	31.10.2010
290	notch filter GSM 900	WRCA 901,9/903,1SS	3RR	Wainwright Industries	12 M	-	31.03.2008
291	high pass filter GSM 850/900	WHJ 2200-4EE	14	Wainwright Industries	12 M	-	31.03.2008
295	Racal Digital Radio Test Set	6103	1572	Racal	24 M	3	31.03.2009
298	Radio Communication Tester	CMU 200	832221/091	Rohde & Schwarz	12 M	-	31.03.2008
299	audio microphone	4134	-	Brüel & Kjaer	pre-m	2	
300	AC LISN (50 Ohm/50µH, 1-phase)	ESH3-Z5	892 239/020	Rohde & Schwarz	12 M	-	31.03.2008
301	attenuator (20 dB) 50W, 18GHz	47-20-33	AW0272	Lucas Weinschel	pre-m	2	

Ref.-No.	Equipment	Type	Serial-No.	Manufacturer	Interval of calibration	Remark	Cal due
302	horn antenna 40 GHz (Meas 1)	BBHA9170	155	Schwarzbeck	24 M	-	31.03.2008
303	horn antenna 40 GHz (Subst 1)	BBHA9170	156	Schwarzbeck	24 M	-	31.03.2008
304	fix dipole antenna 1.6 GHz	EMCO 3125-307	9907-1001	ETS	24 M	-	31.03.2009
305	fix dipole antenna 1.8-2.0 GHz	EMCO 3125-306	9907-1001	ETS	24 M	-	31.03.2009
306	fix dipole antenna 2.45 GHz	EMCO 3125-308	9907-1001	ETS	24 M	-	31.03.2009
307	fix dipole antenna 3 GHz	EMCO 3125-309	9907-1001	ETS	24 M	-	31.03.2009
312	Switch unit	TS-RSP	1000147	R&S	12 M	1f	31.03.2008
317	1000 Hz calibrator 94 dB SPL	4230 94dB	1542286	Brüel & Kjaer	12 M	-	31.03.2008
323	Communication Tester	CMD 55	825878/034	Rohde & Schwarz	12 M	-	31.03.2008
331	climatic test chamber -40/+80 Grad	HC 4055	43146	Heraeus Vötsch	24 M	-	31.10.2008
335	System-CTC-EMS-Conducted	System EMS Conducted	-	Rohde & Schwarz	12 M	5	30.04.2008
337	System CTC OATS	System EMI OATS	-	HD GmbH	12 M	5	30.10.2008
338	pre-amplifier 26GHz	JS4-00102600-38-5P	838697	Miteq	12 M	-	31.03.2008
340	Communication Tester	CMD 55	849709/037	Rohde & Schwarz	12 M	-	31.03.2008
341	digital multimeter	Fluke 112	81650455	Fluke	24 M	-	31.03.2008
342	digital multimeter	Voltcraft M-4660A	IB 255466	Voltercraft	12 M	-	31.03.2008
344	adaptor 150/50 Ohm	150/50	-	Krohne	12 M	-	31.03.2008
345	adaptor 150/50 Ohm	150/50	-	Krohne	12 M	-	31.03.2008
347	laboratory site	radio lab.	-	-	-	3	
348	laboratory site	EMI conducted	-	-	-	3	
349	car battery 12 V	car battery 12 V	without	-	-	3	
350	car battery 12 V	car battery 12 V	without	-	-	3	
354	DC - power supply 40A	NGPE 40/40	448	Rohde & Schwarz	24 M	-	31.03.2008
355	power meter	URV 5	891310/027	Rohde & Schwarz	12 M	-	31.03.2008
356	power sensor	NRV-Z1	882322/014	Rohde & Schwarz	24 M	-	31.03.2008
357	power sensor	NRV-Z1	861761/002	Rohde & Schwarz	24 M	-	31.03.2008
358	Power Amplifier 10 kHz-220MHz	AR75A220M1	15860	Amplifier Research	12 M	1b	30.04.2008
362	TOSM Calibration Kit 50 Ohm	ZV-Z21/ZV-Z11	without	Rohde&Schwarz	12 M	-	31.03.2008
366	Ultra Compact Simulator	UCS 500 M4	V0531100594	EM-Test	12 M	-	31.03.2008
367	audio measurement amplifier	2636	R=316832/001 :	Brüel & Kjaer	12 M	-	31.03.2008
369	insertion unit (SAR-EMS, Ch. A)	URV5-Z2	100301	Rohde & Schwarz	24 M	-	31.03.2008
370	insertion unit (SAR-EMS, Ch. B)	URV5-Z2	100302	Rohde & Schwarz	24 M	-	31.03.2008
374	power amplifier 0.8-3 GHz	60S1G3	306528	Amplifier Research	-	1a	30.04.2008
375	directional coupler	DC7144M1	306498	Amplifier Research	-	1a	30.04.2008
376	horn antenna 6 GHz	BBHA9120 E	BBHA 9120 E 179	Schwarzbeck	12 M	-	31.03.2008
377	emi test receiver	ESCS 30	100160	Rohde & Schwarz	12 M	-	31.03.2008
378	broadband RF field monitor	RadiSense III	03D00013SNO-08	DARE Electronics B.V.	12 M	-	31.03.2008
383	signal generator	SME 03	842 828 /034	Rohde & Schwarz	36 M	-	31.03.2010
386	coupling decoupling network	CDN USB/p	19397	Schaffner	12 M	-	31.03.2008
387	coupling decoupling network	CDN L-801 M2	2051	Lüthi	12 M	-	31.03.2008
388	coupling decoupling network	CDN L-801 T2	1929	Lüthi	12 M	-	31.03.2008
389	digital multimeter	Keithley 2000	0583926	Keithley	24 M	-	31.03.2009
392	Radio Communication Tester	MT8820A	6K00000788	Anritsu	18M	-	31.03.2008
394	power amplifier 80-1000 MHz	BLWA 0810-250/200	045610	Bonn-Elektronik	-	1a	30.04.2008
400	ferrite tube (>15 dB, EN 55022)	FTC 40 X 15 E	5559	Lüthi	12 M	-	31.03.2008
401	ferrite tube (>15 dB, EN 55022)	FTC 40 X 15 E	5560	Lüthi	12 M	-	31.03.2008
411	Test Cable Kit N 50 Ohm (male)	ZV-Z11	100200	R&S / Rosenberger	pre-m	2	
413	Quad-Ridge Horn Antenna	3164-04	00090667	ETS-Lindgren	12 M	1f	31.03.2008
414	Circularly polarized com. Antenna	3102	00033734	EMCO	-	3	
415	Antenna Position Controller	2090	00035634	ETS-Lindgren	-	4	
416	MAPS Positioner	2010	-	ETS-Lindgren	-	4	
420	System CTC CTIA-OTA	System CTC CTIA-OTA	-	ETS-Lindgren/Cetecom	12 M	5	31.03.2008
429	MAPS-Positionier	2015	-	ETS-Lindgren	-	4	
430	Thermo-Hygrometer	H270	54476	Dostmann electronic	24 M	-	30.11.2008
431	Model 7405	Near-Field Probe Set	9305-2457	EMCO	-	4	
432	pre-amplifier 100MHz-26GHz	JS4-00102600-38-5P	1030896	Miteq USA	12 M	-	31.03.2008
436	Radio Communication Tester	CMU 200	103083	Rohde & Schwarz	12 M	-	31.03.2008
439	UltraLog-Antenna	HL 562	100248	Rohde + Schwarz	36 M	-	31.03.2008
440	CDN for Datacable	CDN-UTP	CDN-UTP 029	EMC Partner AG,	24 M	-	31.03.2008
441	System CTC-SAR-EMI	System EMI field (SAR)	-	ETS	12 M	5	31.12.2007
443	System CTC-FAR-EMI-Spuri	System CTC-FAR-EMI-	-	ETS-Lindgren/Cetecom	12 M	5	30.04.2008
444	System CTC FAR-EMS	System EMS-Field (FAR)	-	ETS Lindgren/Cetecom	12 M	5	30.04.2008
448	notch filter WCDMA FDD II	WRCT 1850.0/2170.0-	5	Wainwright Instruments	12 M	1c	31.03.2008
449	notch filter WCDMA FDD V	WRCT 824.0/894.0-5/40-	1	Wainwright Instruments	12 M	1c	31.03.2008
454	Oscilloscope	HM 205-3	9210 P 29661	Hameg	-	4	
455	Oscilloscope	HP 54602B	US 350 336 45	Hawlett Packard	-	4	
456	DC-Power supply 0-5A	EA 3013 S	207810	Elektro Automatik	pre-m	2	
457	DC-Power supply, 0-5A	EA-3013 S	9624680	Elektro Automatik	pre-m	2	
459	DC -power supply 0-5 A , 0-32 V	EA-PS 2032-50	910722	Elektro Automatik	pre-m	2	
460	Radio Communication Tester	CMU 200	108901	Rohde & Schwarz	12 M	-	31.03.2008
462	AF-Generator	MX-2020	-	Conrad	-	4	
463	Universal source	HP3245A	2831A03472	Agilent	-	4	
464	Thermo-Hygro-Monitor	WS-9400	without	Europe Supplies Ltd.	24 M	-	30.11.2008
465	Thermo-Hygro-Monitor	WS-9400	without	Europe Supplies Ltd.	24 M	-	30.11.2008
466	digital multimeter	Fluke 112	89210157	Fluke Corporation USA	24 M	-	31.03.2008
467	digital multimeter	Fluke 112	89680306	Fluke Corporation USA	24 M	-	31.03.2008
468	digital multimeter	Fluke 112	90090455	Fluke Corporation USA	24 M	-	31.03.2008
470	Thermo-Hygro-Monitor	WS-9400	-	distr. by Conrad	24 M	-	30.11.2008
474	EWR-Bandpass 1KHz (3 bandwidth)	MS210R/T2	2610102	IMD GmbH	12 M	2	31.10.2007
476	Spectrum Analyzer	FSM	840500/004	Rohde & Schwarz	24 M	-	31.03.2009
477	ReRadiating GPS-System	AS-47	-	Automotive Consulting	-	3	
482	filtermatrix	FilterMatrix SAR 1	-	CETECOM (Brl)	-	1d	
484	pre-amplifier 2,5 - 18 GHz	AMF-5D-02501800-25-	1244554	Miteq	12 M	-	31.03.2008
487	NSA-Verification of CTC-SAR-EMI	System EMI field (SAR)	-	ETS	12 M	-	31.10.2008
489	emi test receiver	ESU40	1000-30	Rohde & Schwarz	12 M	-	31.03.2008

Ref.-No.	Equipment	Type	Serial-No.	Manufacturer	Interval of calibration	Remark	Cal due
490	high pass 2,65 GHz>18GHz	6HC 2650/18000-3-KK	200709138	Trilithic	12 M	-	31.03.2008
491	ESD Simulator dito	ESD dito	dito307022	EM-Test	24 M	-	31.03.2009
494	power supply (GPIB)	Agilent 66332A	US 37474017	Agilent	24 M	-	31.03.2009
498	Power Supply	NGPE 40/40	402	Rohde & Schwarz	-	2	
500	industry Acoustic System	MO 2000 Set	100048	Sennheiser	-	4	
502	band reject filter	WRCG 1709/1786-	SN 9	Wainwright	-	-	
503	band reject filter	WRCG 824/849-814/859-	SN 5	Wainwright	-	-	
517	relais switc matrix	HF Relais Box Keithley	SE 04	-	-	-	
522	electronical load	EL 9000	-	ELV	-	-	
523	Digitalmultimeter	L4411A	MY46000154	Agilent	24 M	-	31.03.2009
524	Voltage Drop Simulator	VDS 200	0196-16	EM Test	18 M	-	31.03.2009
525	Koppelnetzwerk	CNA 200	1196-01	EM Test	18 M	-	31.03.2009
526	Burst Generator	EFT 200 A	0496-06	EM Test	18 M	-	31.03.2009
527	Micro Pulse Generator	MPG 200 B	0496-05	EM Test	18 M	-	31.03.2009
528	Load Dump Simulator	LD 200B	0496-06	EM Test	18 M	-	31.03.2009
529	6 dB Broadband resistive power divider	Model 1515	LH 855	Weinschel	-	2	
530	10 dB Broadband resistive power divider	R 416110000	LOT 9828	-	2		

7.1.3. Legend

Note / remarks		Calibrated during system calibration:
	1a	System CTC-SAR-EMS (Ref.-No. 442)
	1b	System-CTC-EMS-Conducted (Ref.-No. 335)
	1c	System CTC-FAR-EMI-spurious emission (Ref.-No. 443)
	1d	System CTC-SAR-EMI (Ref.-No. 441)
	1e	System CTC-OATS (EMI radiated) (Ref.-No. 337)
	1 f	System CTC-CTIA-OTA (Ref.-No. 420)
	1 g	System CTC-FAR-EMS (Ref.-No. 444)
	2	calibration or equipment check immediately before measurement
	3	Regulatory maintained equipment for functional check or support purpose, calibration of this equipment has no effect on measuring result
	4	Ancillary equipment without calibration e.g. mechanical equipment or monitoring equipment
	5	Test System

Interval of calibration	12 M	12 month
	24 M	24 month
	36 M	36 month
	Pre-m	check before starting the measurement
	-	without calibration

8. Photographs

See separate documents.

9. ANNEX 1: Diagrams of the measurements

None

10. ANNEX 2: RF-Technical Brief Cover Sheet according RSS-102, Issue 2.

Radio Frequency Exposure Compliance of
Radiocommunication Apparatus (All Frequency Bands)

RSS-102

Annex A - RF Technical Brief Cover Sheet

All Fields must be completed with the requested information or the following codes:
N/A for Not Applicable, N/P for Not Performed or N/V for Not Available.
Where applicable, check appropriate box.

1. COMPANY NUMBER: 267 W
2. MODEL NUMBER: MC55i
3. MANUFACTURER: Siemens AG, ICM WM RD ST3, 13623 Berlin, Germany
4. TYPE OF EVALUATION: Complete the applicable sections: (a) SAR Evaluation: Device Used in the Vicinity of the Human Head; (b) SAR Evaluation: Body-worn Device; (c) RF Evaluation)

Note: The worst-case scenario (i.e. highest measured value obtained) should be reported.

(a) SAR Evaluation: Device used in the Vicinity of the Human Head

- Multiple transmitters: Yes No
- Evaluated against exposure limits: General Public Use Controlled Use
- Duty cycle used in evaluation: _____ %
- Standard used for evaluation: _____
- SAR value: _____ W/kg. Measured Computed Calculated

(b) SAR Evaluation: Body-worn Device

- Multiple transmitters: Yes No
- Evaluated against exposure limits: General Public Use Controlled Use
- Duty cycle used in evaluation: _____ %
- Standard used for evaluation: _____
- SAR value: _____ W/kg. Measured Computed Calculated

(c) RF Evaluation: YES

- Evaluated against exposure limits: General Public Use - YES Controlled Use
- Duty cycle used in evaluation: 100 %
- Standard used for evaluation: RSS-102, Issue 2, November 2005
- Measurement distance: 0,20 m
- RF value: maximum 3,595 W/m²

Measured Computed Calculated - YES

Radio Frequency Exposure Compliance of
Radiocommunication Apparatus (All Frequency Bands) _____ RSS-102

Annex B - Declaration of RF Exposure Compliance

ATTESTATION: I attest that the information provided in Annex A is correct; that a Technical Brief was prepared and the information it contains is correct; that the device evaluation was performed or supervised by me; that applicable measurement methods and evaluation methodologies have been followed and that the device meets the SAR and/or RF exposure limits of RSS-102.	
Signature: _____	Date: 03. January 2008
NAME	(Please print or type): CHRISTIAN OVIDIU LORENZ
TITLE	(Please print or type): DIPL.ING.
COMPANY	(Please print or type): CETECOM GmbH, 45219 ESSEN, GERMANY