



1/F., Building No. 1 Building, Agriculture Machinery Materials Co.
Wushan Road, Shipai, Tianhe District, Guangzhou, China
Telephone: +86 (0) 20 3848 1001 Fax: +86 (0) 20 3848 1006
Email: sgs_internet_operations@sgs.com

FEDERAL COMMUNICATIONS COMMISSION
Registration number: 282399

Report No.: GLEMO050702138RFF(I)
Page : 1 of 9
FCC ID : TB7DXTOYS51949

TEST REPORT

Application No. : GLEMO050702138RF
Applicant : SHANTOU CHENGHAI DONGXIN PLASTIC TOYS CO., LTD.
FCC ID : TB7DXTOYS51949
Fundamental Frequency : 49.860MHz
Equipment under Test (EUT):
Name : Toy – R/C Cyclone Stunt (49.860MHz)
Item No.: #1603105
Customer PO No.: DSM5681
Standards : FCC PART 15, SUBPART C : 2004
Section 15.235
Date of Receipt : 26 July 2005
Date of Test : 26 July to 9 August 2005
Date of Issue : 11 August 2005

Test Result :	PASS *
----------------------	---------------

* In the configuration tested, the EUT complied with the standards specified above.

Authorized Signature:

Kent Hsu
Laboratory Manager

This report refers to the General Conditions for Inspection and Testing Services, printed overleaf
This report details the results of the testing carried out on one sample. The results contained in this test report do not relate to other samples of the same product. The manufacturer should ensure that all products in series production are in conformity with the product sample detailed in this report.
This report may only be reproduced and distributed in full. If the product in this report is used in any configuration other than that detailed in the report, the manufacturer must ensure the new system complies with all relevant standards. Any mention of SGS International Electrical Approvals or testing done by SGS International Electrical Approvals in connection with, distribution or use of the product described in this report must be approved by SGS International Electrical Approvals in writing.
The report must not be used by the client to claim product certification, approval, or endorsement by NVLAP, NIST, or any agency of the federal government.
All test results in this report can be traceable to National or International Standards.

2 Test Summary

Test	Test Requirement	Standard Paragraph	Result
Radiated Emission (30MHz to 1000MHz)	FCC PART 15 :2004	Section 15.235	PASS ①
Occupied Bandwidth	FCC PART 15 :2004	Section 15.235	PASS

Remark:

①The EUT passed Radiated Emission test after the modification as shown as the below:

- Added three capacitors as below:

C101: 30PF, C102: 0.01 μ F, C103: 47PF.

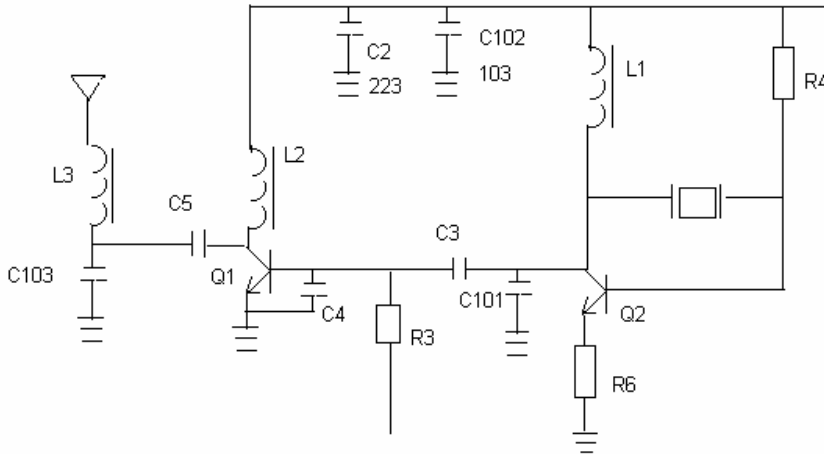



3 Contents

	Page
1 COVER PAGE	1
2 TEST SUMMARY	2
3 CONTENTS	3
4 GENERAL INFORMATION	4
4.1 CLIENT INFORMATION	4
4.2 DETAILS OF E.U.T.	4
4.3 DESCRIPTION OF SUPPORT UNITS	4
4.4 TEST LOCATION	4
4.5 OTHER INFORMATION REQUESTED BY THE CUSTOMER	4
4.6 TEST FACILITY.....	5
5 TEST RESULTS	6
5.1 TEST INSTRUMENTS	6
5.2 E.U.T. OPERATION	6
5.3 TEST PROCEDURE & MEASUREMENT DATA.....	6
5.3.1 <i>Radiated Emissions</i>	6
5.3.2 <i>Occupied Bandwidth</i>	9



4 General Information

4.1 Client Information

Applicant: SHANTOU CHENGHAI DONGXIN PLASTIC TOYS CO., LTD.
Address of Applicant: Crossing, Fengxin San Rd. Laiwu Rd. Chenghai District, Shantou, Guangdong, China.

4.2 Details of E.U.T.

Product Name: Toy – R/C Cyclone Stunt (49.860MHz)
Item No.: #1603105
Power Supply: 9V DC (1 x '6F22' Battery) for the Tx
Power Cord: N/A-

4.3 Description of Support Units

The EUT was tested as an independent unit: a 49MHz radio transmitter.

4.4 Test Location

All tests were performed at:

SGS-CSTC Standards Technical Services Ltd., Guangzhou EMC Laboratory, 1/F, Building No. 1, Agriculture Machinery Materials Company Warehouse Ltd., Wushan Road Shipai, Tianhe District, Guangzhou, China. P.C. 510630.

Tel: +86 20 3848 1001

Fax: +86 20 3848 1006

4.5 Other Information Requested by the Customer

None.



4.6 Test Facility

The test facility is recognized, certified, or accredited by the following organizations:

- **NVLAP – Lab Code: 200611-0**
SGS-CSTC Standards Technical Services Co., Ltd., Guangzhou EMC Laboratory is recognized under the National Voluntary Laboratory Accreditation Program (NVLAP/NIST). NVLAP Code: 200611-0. Effective through December 31, 2005.
- **ACA**
SGS-CSTC Standards Technical Services Co., Ltd., EMC Laboratory can also perform testing for the Australian C-Tick mark as a result of our NVLAP accreditation.
- **VCCI**
The 3m Semi-anechoic chamber and Shielded Room (11.5m x 4m x 4m) of SGS-CSTC Standards Technical Services Co., Ltd. have been registered in accordance with the Regulations for Voluntary Control Measures with Registration No.: R-1599 and C-1706 respectively.
Date of Registration: June 01, 2005. Valid until February 22, 2008
- **SGS UK(Certificate No.: 32), SGS-TUV SAARLAND and SGS-FIMKO**
Have approved SGS-CSTC Standards Technical Services Co., Ltd., EMC Laboratory as a supplier of EMC TESTING SERVICES and SAFETY TESTING SERVICES.
- **CNAL – LAB Code: L0141**
SGS-CSTC Standards Technical Services Co., Ltd., EMC Laboratory has been assessed and in compliance with CNAL/AC01:2002 accreditation criteria for testing laboratories (identical to ISO/IEC 17025:1999 General Requirements) for the Competence of Testing Laboratories.
- **FCC – Registration No.: 282399**
SGS-CSTC Standards Technical Services Co., Ltd., EMC Laboratory has been registered and fully described in a report filed with the (FCC) Federal Communications Commission. The acceptance letter from the FCC is maintained in our files. Registration 282399, May 31, 2002. With the above and NVLAP's accreditation, SGS-CSTC is an authorised test laboratory for the DoC process.
- **Industry Canada (IC)**
The 3m Semi-anechoic chamber of SGS-CSTC Standards Technical Services Co., Ltd. has been registered by Certification and Engineering Bureau of Industry Canada for radio equipment testing with Registration No.: 5169.



5 Test Results

5.1 Test Instruments

RE in Chamber						
No:	Test Equipment	Manufacturer	Model No.	Serial No.	Cal. Date (dd-mm-yy)	Cal.Due date (dd-mm-yy)
1	3m Semi- Anechoic Chamber	Frankonia	N/A	N/A	31-01-2005	30-01-2006
2	EMI Test Receiver	Rohde & Schwarz	ESIB26	100249	20-09-2004	20-09-2005
3	EMI Test Software	Audix	E3	N/A	N/A	N/A
4	Coaxial cable	SGS	N/A	N/A	05-12-2003	04-12-2005
5	Bilog Type Antenna	Schaffner -Chase	CBL6143	5070	17-01-2005	16-01-2006
6	Horn Antenna	Rohde & Schwarz	HF906	100095	10-05-2005	09-05-2006
7	Spectrum Analyzer	Rohde & Schwarz	FSP30	100324	29-10-2004	28-10-2005
8	0.1-1300 MHz Pre-Amplifier	HP	8447D OPT 010	2944A06252	31-06-2005	30-06-2006
9	1-26.5 GHz Pre-Amplifier	Agilent	8449B	3008A01649	26-01-2004	25-01-2006
10	Active Loop Antenna	EMCO	6502	00042963	14-Jan-2005	14-Jan-2006

5.2 E.U.T. Operation

Input voltage: 9V DC (1 x '6F22' Battery)

Operating Environment:

Temperature: 25.0 °C

Humidity: 50 % RH

Atmospheric Pressure: 1013 mbar

EUT Operation:

Test the EUT in transmitting mode.

5.3 Test Procedure & Measurement Data

5.3.1 Radiated Emissions

Test Requirement: FCC Part15 C Section 15.235

Test Method: ANSI C63.4

Test Date: 27 July 2005 (Initial Test);
9 August 2005 (Test after modification)

Measurement Distance: 3m (Semi-Anechoic Chamber)

Requirements: Carrier frequency will not exceed 80dBuV/m at 3m.

Out of band emissions shall not exceed:

40.0 dB μ V/m between 30MHz & 88MHz

43.5 dB μ V/m between 88MHz & 216MHz

46.0 dB μ V/m between 216MHz & 960MHz

54.0 dB μ V/m above 960MHz

Detector: Peak Scan (120kHz resolution bandwidth)



SGS-CSTC Standards Technical Services Ltd.

Report No.: GLEMO050702138RFF(I)

Page : 7 of 9

FCC ID : TB7DXTOYS51949

Test Procedure: The procedure used was ANSI Standard C63.4-2003. The receiver was scanned from 30MHz to 1000MHz. When an emission was found, the table was rotated to produce the maximum signal strength. An initial pre-scan was performed for in peak detection mode using the receiver. The EUT was measured for both the Horizontal and Vertical polarities and performed a pre-test three orthogonal planes. The worst case emissions were reported.

An initial pre-scan was performed in the 3m chamber using the spectrum analyser in peak detection mode. Quasi-peak measurements were conducted based on the peak sweep graph. The EUT was measured by Bilog antenna with 2 orthogonal polarities.

The following measurements were performed on the EUT on 9 August 2005:

Test the EUT in transmitting mode.

Intentional emission

Test Frequency (MHz)	Peak (dB μ V/m)		Limits (dB μ V/m)	Margin (dB)	
	Vertical	Horizontal		Vertical	Horizontal
49.860	74.19	54.70	100.0	25.81	45.30

Test Frequency (MHz)	Average (dB μ V/m)		Limits (dB μ V/m)	Margin (dB)	
	Vertical	Horizontal		Vertical	Horizontal
49.860	70.33	50.85	80.0	9.67	29.15



SGS-CSTC Standards Technical Services Ltd.

Report No.: GLEMO050702138RFF(I)
 Page : 8 of 9
 FCC ID : TB7DXTOYS51949

Other emissions

Vertical:

	Freq	Level	Limit	Over	ReadAntenna	Cable	Preamp
	MHz	dBuV/m	Line	Limit	Level	Loss	Factor
			dBuV/m	dB	dBuV	dB/m	dB
3	99.720	32.37	43.50	-11.13	46.67	10.10	25.10
4	149.680	21.65	43.50	-21.85	33.13	12.44	24.91
5	199.440	41.12	43.50	-2.38	53.58	10.85	24.61
6	249.300	40.22	46.00	-5.78	50.65	12.47	24.40
7	299.160	29.74	46.00	-16.26	37.99	14.46	24.40
8	299.160	29.67	46.00	-16.33	37.91	14.46	24.40
9	349.020	21.03	46.00	-24.97	28.07	15.76	24.71
10	448.740	16.36	46.00	-29.64	23.32	16.24	25.46
11	498.600	17.90	46.00	-28.10	25.80	15.60	25.90

-1-

Horizontal:

	Freq	Level	Limit	Over	ReadAntenna	Cable	Preamp
	MHz	dBuV/m	Line	Limit	Level	Loss	Factor
			dBuV/m	dB	dBuV	dB/m	dB
3	99.720	18.86	43.50	-24.64	33.16	10.10	25.10
4	149.680	12.04	43.50	-31.46	23.52	12.44	24.91
5	199.440	27.95	43.50	-15.55	40.41	10.85	24.61
6	249.300	28.31	46.00	-17.69	38.74	12.47	24.40
7	299.160	19.42	46.00	-26.58	27.66	14.46	24.40
8	349.020	24.99	46.00	-21.01	32.04	15.76	24.71
9	398.880	16.36	46.00	-29.64	22.39	16.87	24.99
10	448.740	16.06	46.00	-29.94	23.02	16.24	25.46
11	498.600	15.33	46.00	-30.67	23.23	15.60	25.90

-1-

Remark:

According to 15.35 (b) When average radiated emission measurements are specified in the regulations, including emission measurements below 1000 MHz, there is also a limit on the radio frequency emissions, as measured using instrumentation with a peak detector

function, corresponding to 20 dB above the maximum permitted average limit for the frequency being investigated unless a different peak emission limit is otherwise specified in the rules, e.g., see Section 15.255.

Test Results: The unit does meet the FCC Part 15 C Section 15.235 requirements.



5.3.2 Occupied Bandwidth

Test Requirement: FCC Part15 C Section 15.235
Test Method: ANSI C63.4
Operation within the band 49.82 – 49.90 MHz
Test Date: 10 August 2005

Requirements: The field strength of any emissions appearing between the band edges and up to 10 kHz above and below the band edges shall be attenuated at least 26 dB below the level of the unmodulated carrier or to the general limits in Section 15.209, whichever permits the higher emission levels. The field strength of any emissions removed by more than 10 KHz from the band edges shall not exceed the general radiated emission limits in Section 15.209.

Method of measurement: The useful radiated emission from the EUT was detected by the spectrum analyser with peak detector. The vertical Scale is set to -10dB per division. The horizontal scale is set to 10 KHz per division.

The graph as below, represents the emissions take for this device.

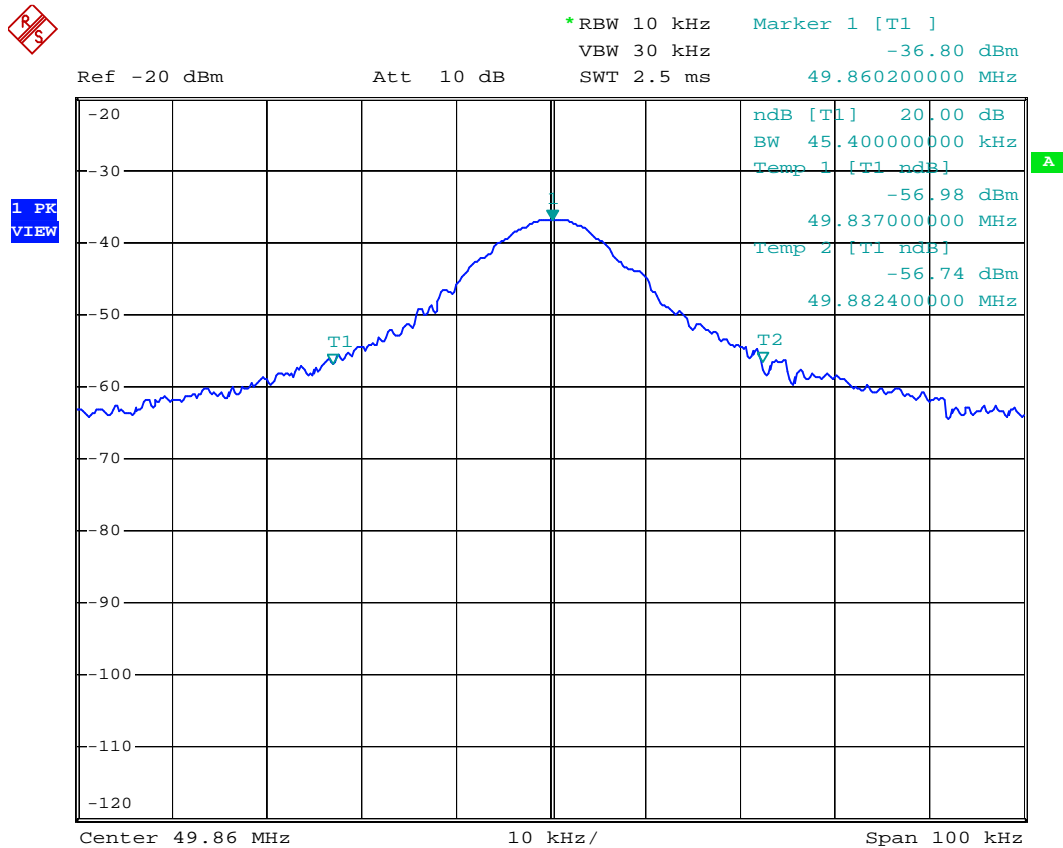

Date: 10.AUG.2005 10:22:06

The results: The unit does meet the FCC Part 15 C Section 15.235 requirements.