



Add value.  
Inspire trust.



# Report On

FCC Testing of the Ericsson Remote Radio 4415 B70,  
KRC 161 760/1, NR (1995-2020 MHz), in a Base Station configuration  
in accordance with FCC CFR 47 Part 2 and FCC CFR 47 Part 27

COMMERCIAL-IN-CONFIDENCE

FCC: TA8AKRC161760-3

PREPARED BY

APPROVED BY

DATED

Handwritten signature of Maggie Whiting in black ink.

Maggie Whiting  
Key Account Manager

Handwritten signature of Steve Scarfe in black ink.

Steve Scarfe  
Authorised Signatory

04 January 2021

Document 75950227 Report 04 Issue 3

January 2021



## CONTENTS

Section	Page No
<b>1</b>	<b>REPORT INFORMATION ..... 2</b>
1.1	Report Details ..... 3
1.2	Brief Summary of Results ..... 4
1.3	Configuration Description ..... 5
1.4	Declaration of Build Status ..... 6
1.5	Product Information ..... 7
1.6	Test Setup ..... 8
1.7	Test Conditions ..... 9
1.8	Deviation From The Standard ..... 9
1.9	Modification Record ..... 9
<b>2</b>	<b>TEST DETAILS ..... 10</b>
2.1	Maximum Peak Output Power and Peak to Average Ratio - Conducted ..... 11
2.2	Occupied Bandwidth ..... 20
2.3	Band Edge ..... 27
2.4	Transmitter Spurious Emissions ..... 33
<b>3</b>	<b>TEST EQUIPMENT USED ..... 64</b>
3.1	Test Equipment Used ..... 65
3.2	Measurement Uncertainty ..... 67
<b>4</b>	<b>ACCREDITATION, DISCLAIMERS AND COPYRIGHT ..... 68</b>
4.1	Accreditation, Disclaimers and Copyright ..... 69
<b>ANNEX A</b>	<b>Module Lists ..... A.2</b>



## **SECTION 1**

### **REPORT INFORMATION**



## 1.1 REPORT DETAILS

Manufacturer	Ericsson AB
Address	Torshamnsgatan 23 Kista SE-16480 Stockholm Sweden
Product Name & Product Number	Radio 4415 B70 & KRC 161 760/3
Serial Number(s)	D827942869
Software Version	CXP9013268/15 Rev R8FN
Hardware Version	R5B
Test Specification/Issue/Date	FCC CFR 47 Part 2: 2019 FCC CFR 47 Part 27: 2019
Test Plan	Q4 FCC_IC test plan for NR legacy
Start of Test	10 November 2020
Finish of Test	11 November 2020
Name of Engineer(s)	Neil Rousell
Related Document(s)	KDB 971168 D01 v02r02 KDB 662911 D01 v02r01

---

### ENGINEERING STATEMENT

The measurements shown in this report were made in accordance with the procedures described on test pages. All reported testing was carried out on a sample equipment to demonstrate compliance with FCC CFR 47 Part 2: 2019, FCC CFR 47 Part 27: 2019. The sample tested was found to comply with the requirements defined in the applied rules.

Test Engineer(s);

Neil Rousell

**This Report has been up issued to Issue 3 and should be read in place of Issue 2. This Report has been up issued to Issue 3 to change the Rule Part and to remove ISED references.**



## 1.2 BRIEF SUMMARY OF RESULTS

A brief summary of results for each configuration, in accordance with FCC CFR 47 Part 2, FCC CFR 47 Part 27 is shown below.

Section	Specification Clause		Test Description	Result
	FCC CFR 47 Part 2	FCC CFR 47 Part 27		
-	-	-	Equivalent Isotropically Radiated Power (EIRP)	N/A <sup>1</sup>
2.1	2.1046	27.50	Maximum Peak Output Power and Peak to Average Ratio - Conducted	Pass
2.2	2.1049	27.53	Occupied Bandwidth	Pass
2.3	2.1051	27.53 (h)	Band Edge	Pass
2.4	2.1051	27.53 (h)	Transmitter Spurious Emissions	Pass

N/A<sup>1</sup> – Not Applicable, due to no integral antenna

N/A – Not Applicable

This unit was tested without an antenna. ERP/EIRP compliance is addressed at the time of licensing, as required by the responsible IC Bureau(s). Licensees are required to take into account the maximum allowed antenna gain used in combination with the power settings to prevent the radiated output power exceeding the limits.



### 1.3 CONFIGURATION DESCRIPTION

Configuration	RAT	No. Of carriers	Carrier Bandwidth	Carrier Frequency Configuration (MHz)		
				Bottom	Middle	Top
A1	NR	1	5 MHz – SCS 15kHz	1997.5	2007.5	2017.5
	NR	1	10 MHz – SCS 15kHz	2000.0	2007.5	2015.0
	NR	1	15 MHz – SCS 15kHz	2002.5	2007.5	2012.5
	NR	1	20 MHz – SCS 15 kHz	2005.0	2007.5	2010.0



1.4 DECLARATION OF BUILD STATUS

<b>MAIN EUT</b>	
<b>MANUFACTURING DESCRIPTION</b>	Radio Unit
<b>MANUFACTURER</b>	Ericsson AB
<b>PRODUCT NAME</b>	Radio 4415 B70
<b>PART NUMBER</b>	KRC161760/3
<b>IC MODEL NAME</b>	AS1617603
<b>SERIAL NUMBER</b>	D827942869
<b>HARDWARE VERSION</b>	R5B
<b>SOFTWARE VERSION</b>	CXP9013268/15 Rev R8FN
<b>TRANSMITTER OPERATING RANGE</b>	B70: 1995 -2020 MHz (DL) 1695 -1710 MHz (UL)
<b>MODULATIONS</b>	LTE & NR: QPSK, 16QAM, 64QAM, 256QAM
<b>ITU DESIGNATION OF EMISSION</b>	LTE 5 MHz BW channel: 5M00F9W
	LTE 10 MHz BW channel: 10M0F9W
	LTE 15 MHz BW channel: 15M0F9W
	LTE 20 MHz BW channel: 20M0F9W
	NR 5 MHz BW channel:4M47W7D
	NR 10 MHz BW channel: 9M29W7D
	NR 15 MHz BW channel: 14M1W7D
<b>OUTPUT POWER (RMS) (W or dBm)</b>	4 ports, 40W per port
<b>FCC ID</b>	TA8AKRC161760-3
<b>TECHNICAL DESCRIPTION (a brief description of the intended use and operation)</b>	Base station radio

Signature Faysal Pirmohamed  
Faysal Pirmohamed

Date 2020-12-01

No responsibility will be accepted by TÜV SÜD Product Service UK Limited as to the accuracy of the information declared in this document by the manufacturer

## 1.5 PRODUCT INFORMATION

### 1.5.1 Technical Description

The Equipment Under Test (EUT) Radio 4415 B70 is an Ericsson AB Radio Unit working in the public mobile service 1995-2020 MHz band which provides communication connections to 1995-2020 MHz network. The Radio 4415 B70 operates from a -48V DC supply.

The Equipment Under Test (EUT) is shown in the photograph below. A full technical description can be found in the Manufacturer's documentation.

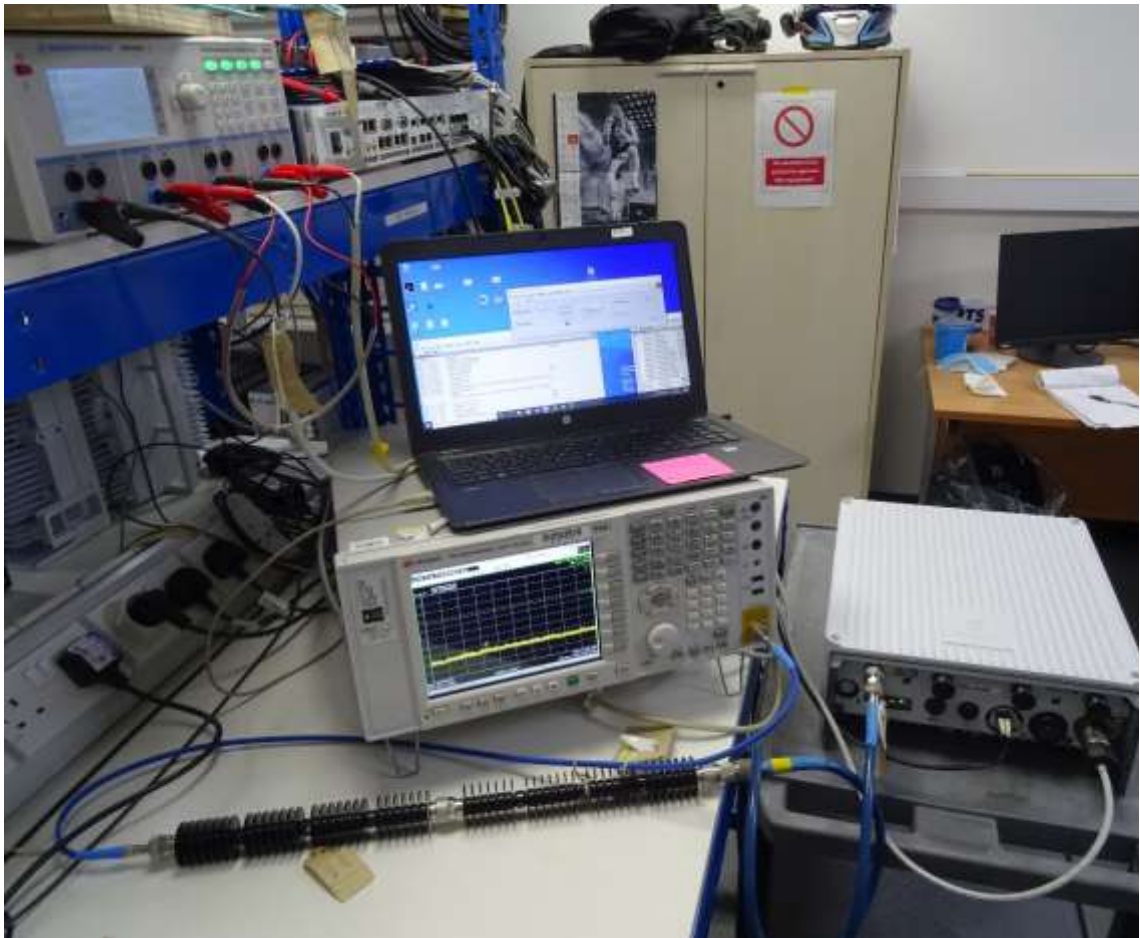

Equipment Under Test





## 1.6 TEST SETUP

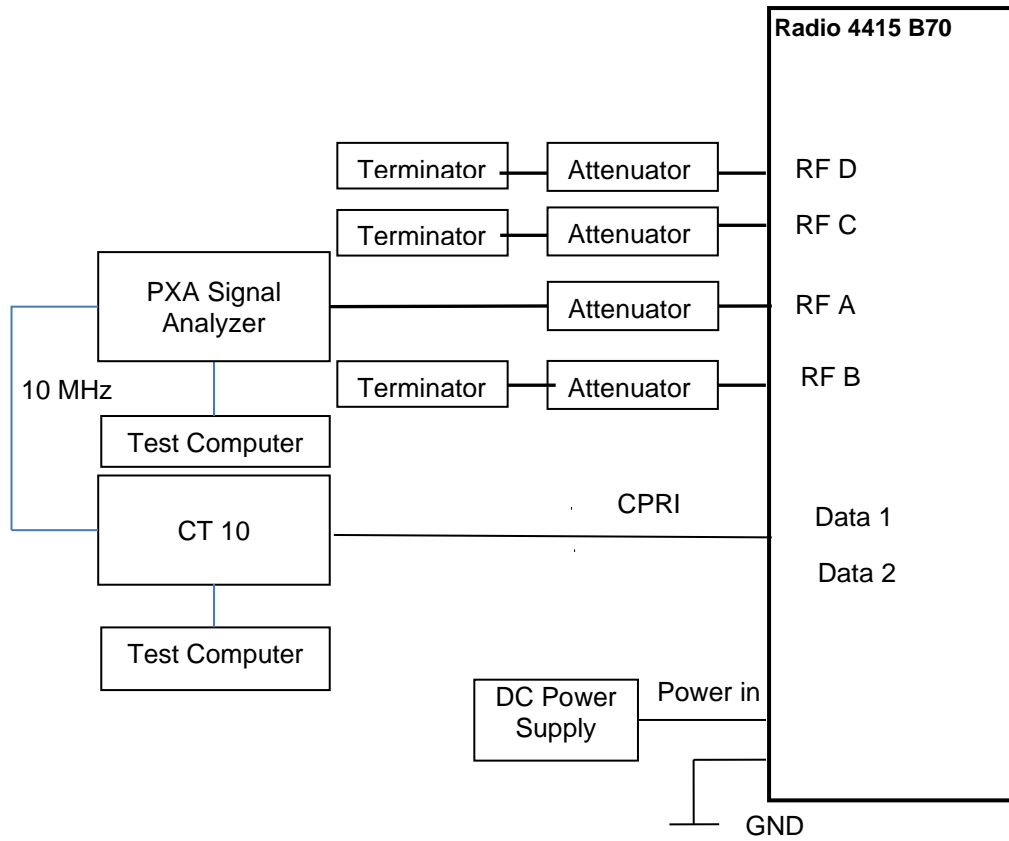



## 1.7 TEST CONDITIONS

For all tests the EUT was set up in accordance with the relevant test standard and to represent typical operating conditions. Tests were applied with the EUT situated as described in the Test Method for each Test.

The EUT was powered from a -48V DC supply.

FCC Measurement Facility Registration Number  
90987 Octagon House, Fareham Test Laboratory

Test Name	Name of Engineer(s)
Maximum Peak Output Power and Peak to Average Ratio - Conducted	Neil Rousell
Occupied Bandwidth	Neil Rousell
Band Edge	Neil Rousell
Transmitter Spurious Emissions	Neil Rousell

## 1.8 DEVIATION FROM THE STANDARD

No deviations from the applicable test standards or test plan were made during testing.

## 1.9 MODIFICATION RECORD

No modifications were made to the EUT during testing.



## **SECTION 2**

### **TEST DETAILS**



**2.1 MAXIMUM PEAK OUTPUT POWER AND PEAK TO AVERAGE RATIO - CONDUCTED**

**2.1.1 Specification Reference**

FCC CFR 47 Part 2, Clause 2.1046  
 FCC CFR 47 Part 27, Clause 27.50

**2.1.2 Date of Test and Modification State**

11 November 2020 - Modification State 0

**2.1.3 Test Equipment Used**

The major items of test equipment used for the above tests are identified in Section 3.1.

**2.1.4 Environmental Conditions**

Ambient Temperature 23.5°C  
 Relative Humidity 51.3%

**2.1.5 Test Method**

All measurements were made in accordance with FCC KDB 971168 D01, clause 5.2.1 and summed in accordance with FCC KDB 662911 D01.

**2.1.6 Test Results**

Configuration A1

Maximum Output Power 46 dBm

Antenna	NR Modulation	NR Carrier Bandwidth	Peak to Average Ratio (PAR) / Output Power			
			Channel Position B			
			PAR (dB)	Average Power		Total Power Ports A + B+C+D dBm
dBm	dBm/MHz					
A	QPSK	5.0 MHz 15 kHz SCS	7.48	45.98	39.99	52.00
A	QPSK	10.0 MHz 15 kHz SCS	7.41	46.00	37.32	52.02
A	QPSK	15.0 MHz 15 kHz SCS	7.46	45.99	35.42	52.01
A	QPSK	20.0 MHz 15 kHz SCS	7.44	46.04	34.32	52.06

Remarks

Calculations: Total power = measured output power (port A, worst case) + 10log (4) and PSD = measured output power – (10\*log(OBW/1MHz)).



Antenna A - NR Modulation QPSK - NR Carrier Bandwidth 5.0 MHz 15 kHz SCS - Channel Position B

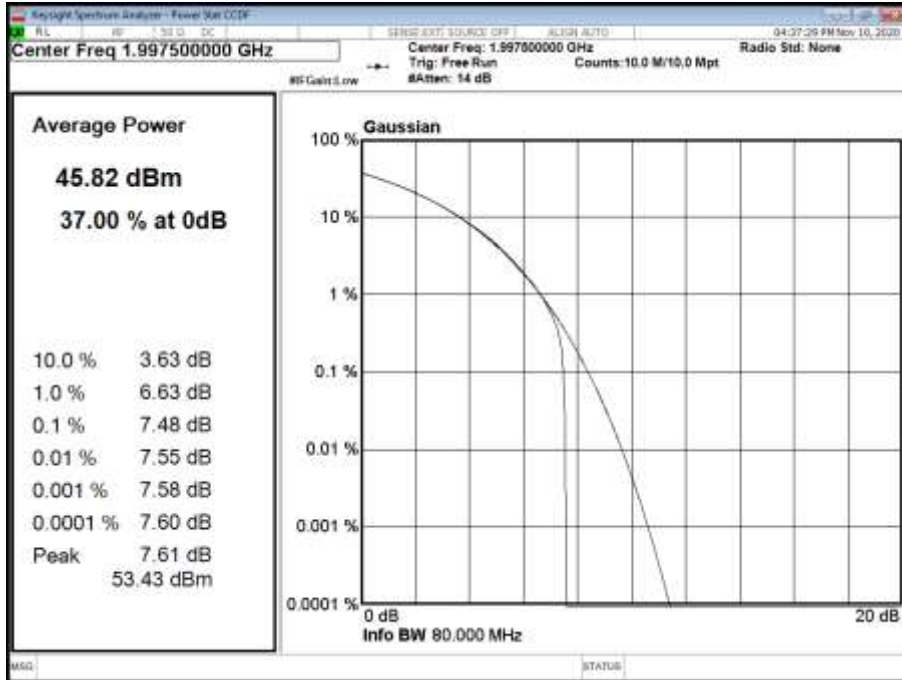

Antenna A - NR Modulation QPSK - NR Carrier Bandwidth 10.0 MHz 15 kHz SCS - Channel Position B

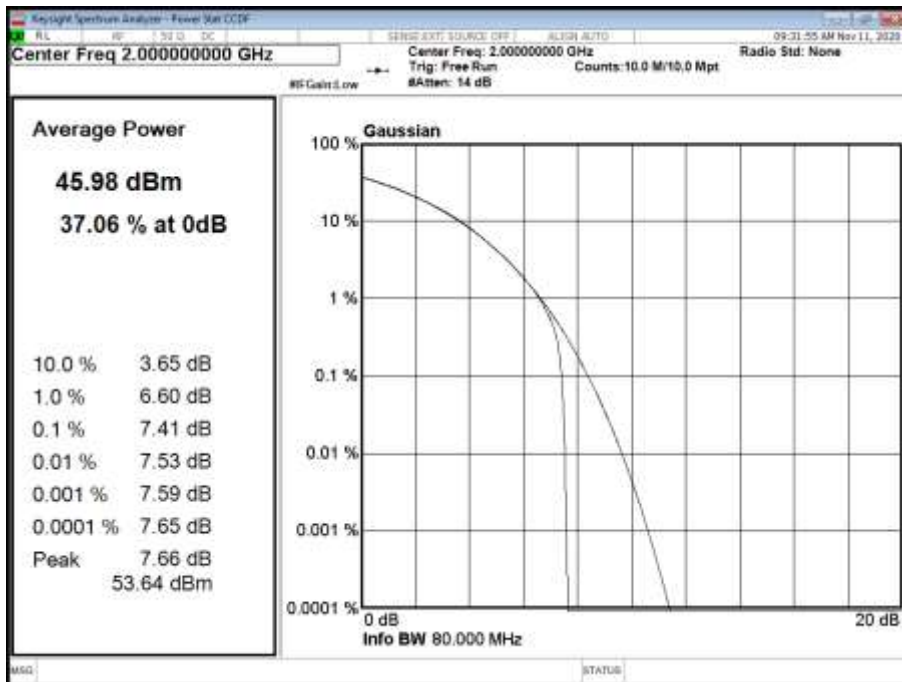



Antenna A - NR Modulation QPSK - NR Carrier Bandwidth 15.0 MHz 15 kHz SCS - Channel Position B

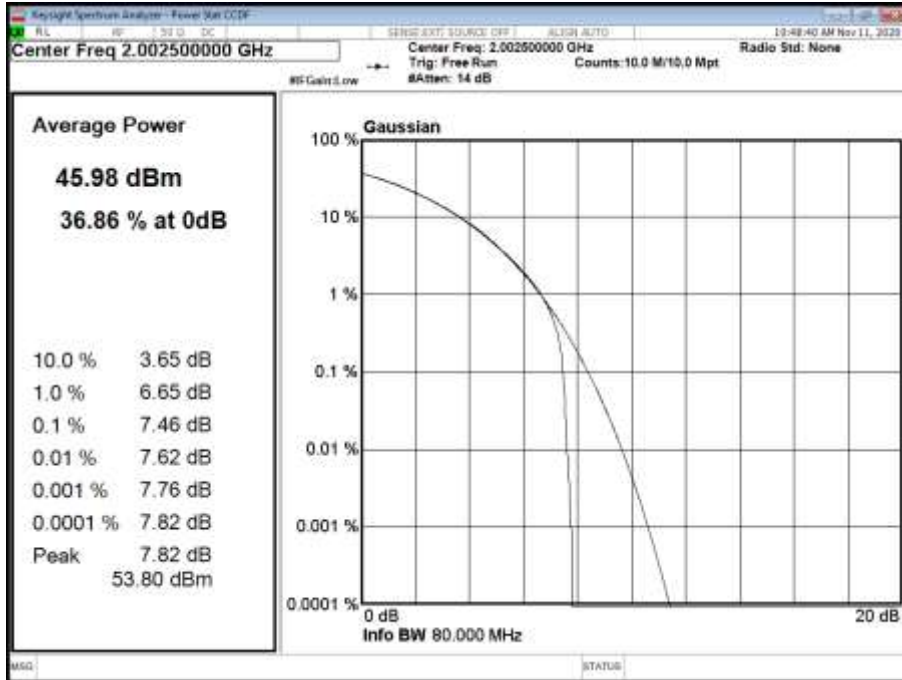

Antenna A - NR Modulation QPSK - NR Carrier Bandwidth 20.0 MHz 15 kHz SCS - Channel Position B

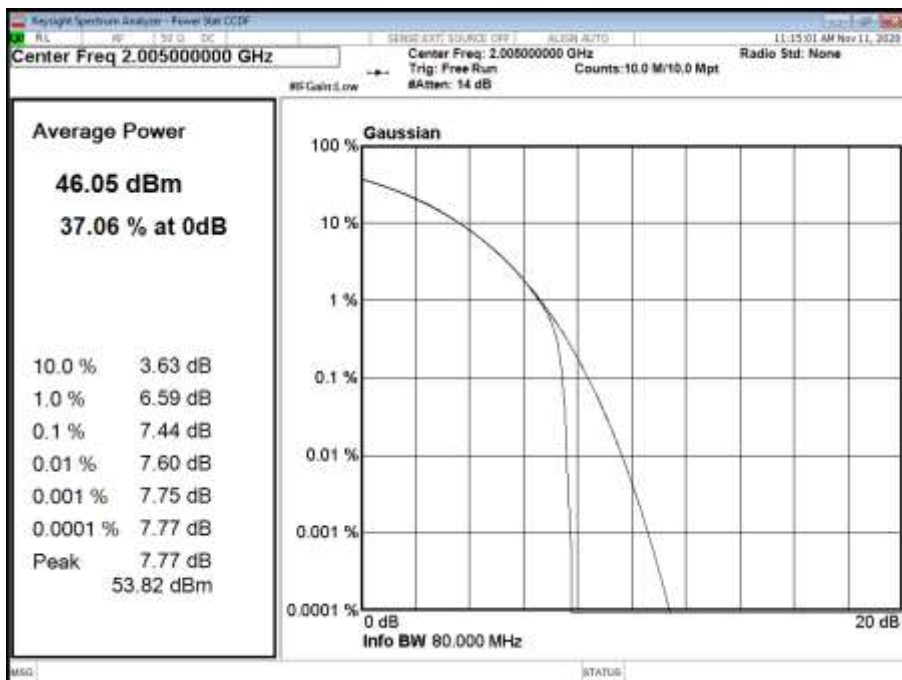



Configuration A1

Maximum Output Power 46 dBm

Antenna	NR Modulation	NR Carrier Bandwidth	Peak to Average Ratio (PAR) / Output Power			
			Channel Position M			
			PAR (dB)	Average Power		Total Power Ports A + B+C+D dBm
				dBm	dBm/MHz	
A	QPSK	5.0 MHz 15 kHz SCS	7.45	46.09	40.09	52.11
A	QPSK	10.0 MHz 15 kHz SCS	7.39	46.20	37.33	52.22
A	QPSK	15.0 MHz 15 kHz SCS	7.45	46.09	35.57	52.11
A	QPSK	20.0 MHz 15 kHz SCS	7.44	46.09	34.29	52.11

Remarks

Calculations: Total power = measured output power (port A, worst case) + 10log (4) and PSD = measured output power – (10\*log(OBW/1MHz)).

Antenna A - NR Modulation QPSK - NR Carrier Bandwidth 5.0 MHz 15 kHz SCS - Channel Position M

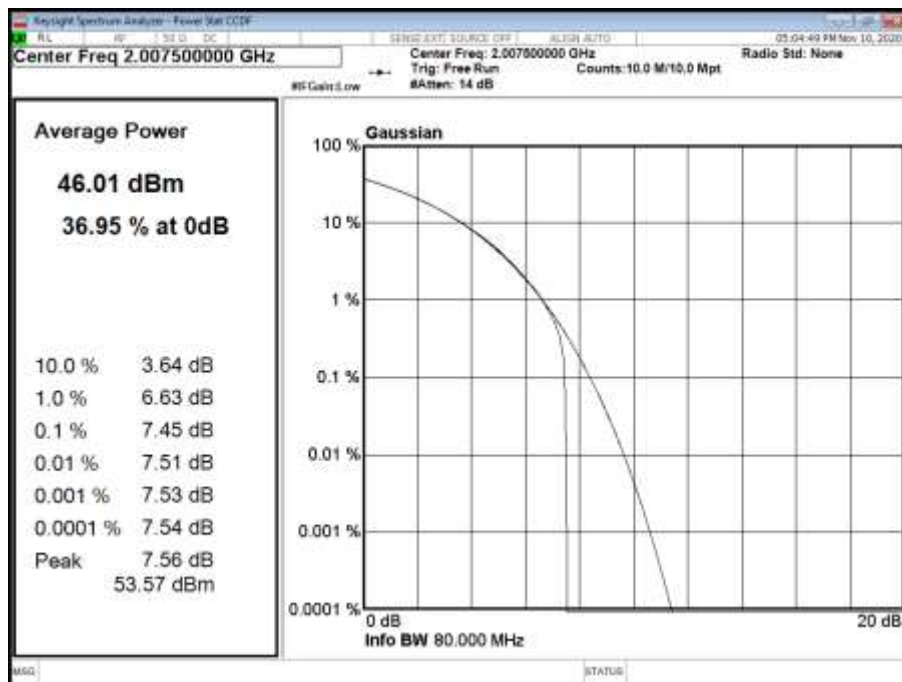



Antenna A - NR Modulation QPSK - NR Carrier Bandwidth 10.0 MHz 15 kHz SCS - Channel Position M

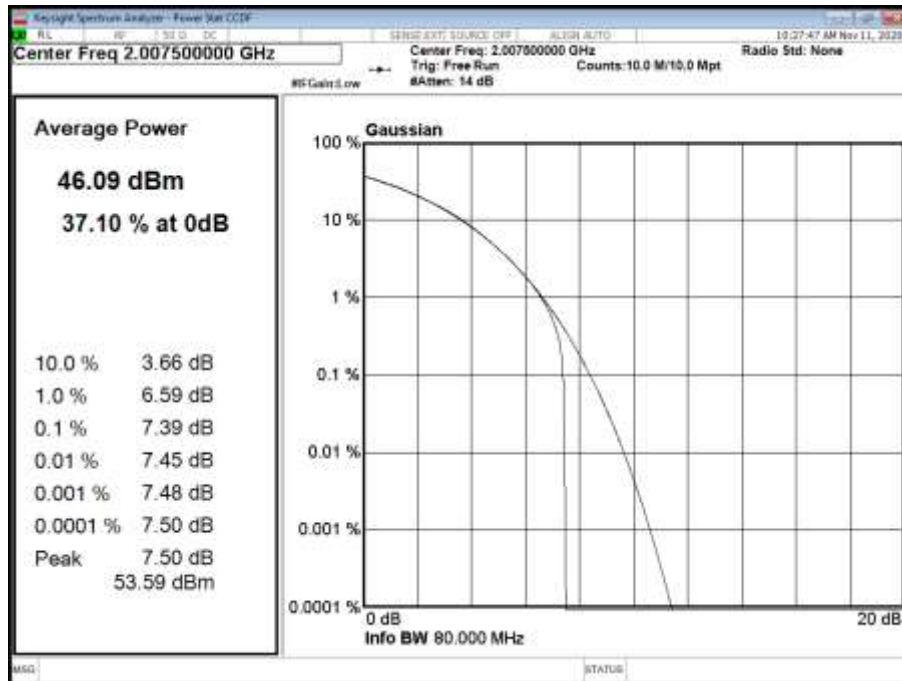

Antenna A - NR Modulation QPSK - NR Carrier Bandwidth 15.0 MHz 15 kHz SCS - Channel Position M

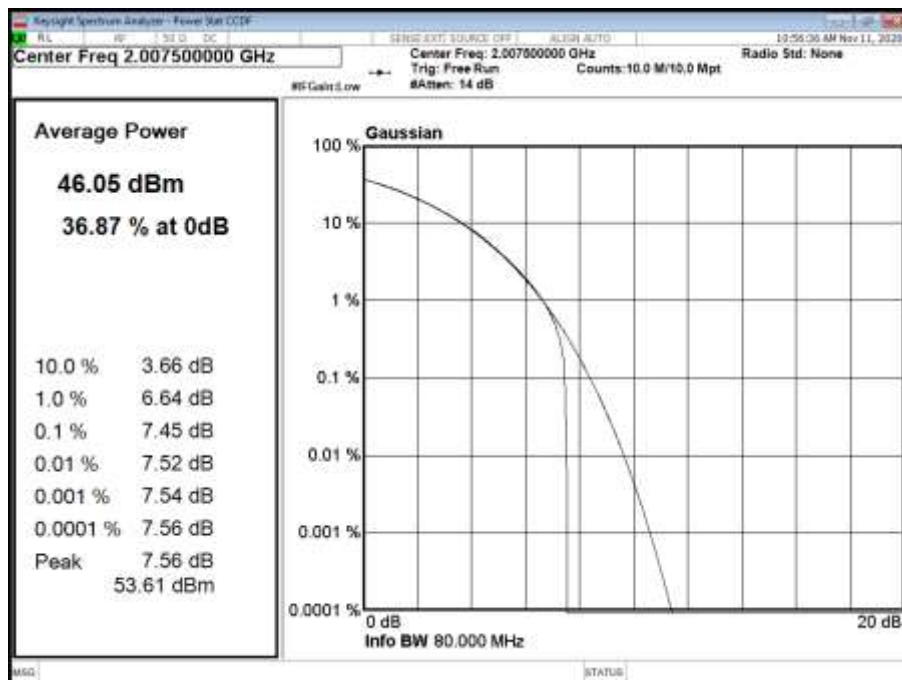





Antenna A - NR Modulation QPSK - NR Carrier Bandwidth 20.0 MHz 15 kHz SCS - Channel Position M

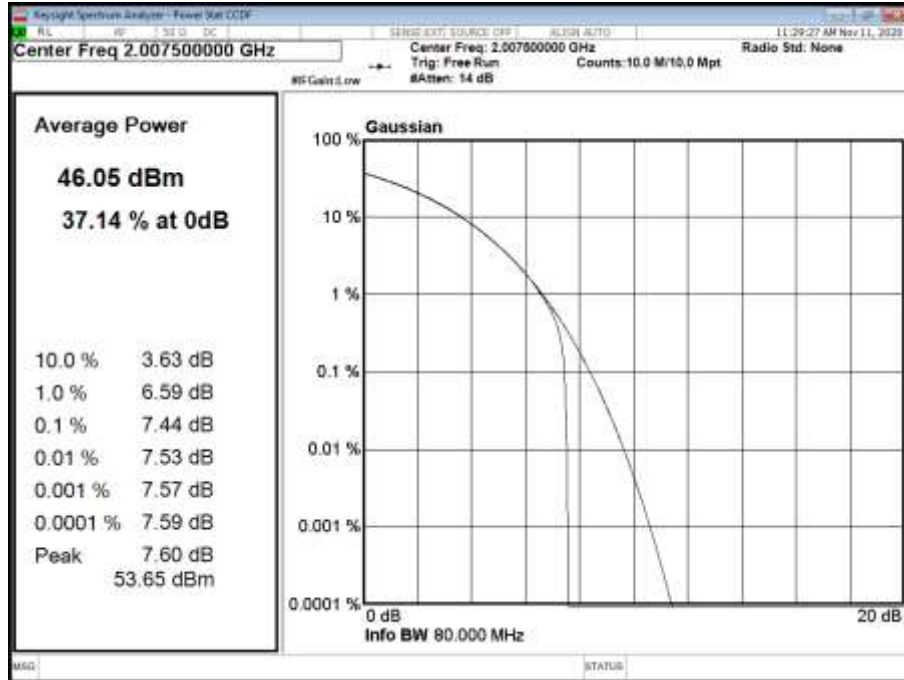

Configuration A1

Maximum Output Power 46 dBm

Antenna	NR Modulation	NR Carrier Bandwidth	Peak to Average Ratio (PAR) / Output Power			
			Channel Position T			
			PAR (dB)	Average Power		Total Power Ports A + B+C+D
			dBm	dBm/MHz	dBm	
A	QPSK	5.0 MHz 15 kHz SCS	7.50	46.07	40.09	52.09
A	QPSK	10.0 MHz 15 kHz SCS	7.41	46.08	37.29	52.10
A	QPSK	15.0 MHz 15 kHz SCS	7.46	46.15	35.55	52.17
A	QPSK	20.0 MHz 15 kHz SCS	7.46	46.14	34.44	52.16

Remarks

Calculations: Total power = measured output power (port A, worst case) + 10log (4) and PSD = measured output power – (10\*log(OBW/1MHz)).



Antenna A - NR Modulation QPSK - NR Carrier Bandwidth 5.0 MHz 15 kHz SCS - Channel Position T

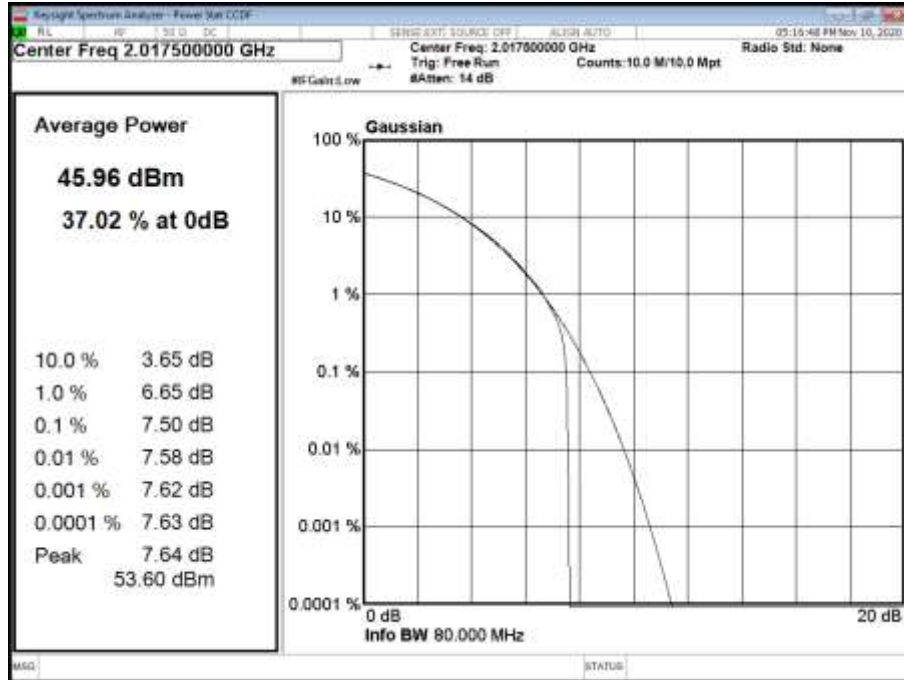

Antenna A - NR Modulation QPSK - NR Carrier Bandwidth 10.0 MHz 15 kHz SCS - Channel Position T

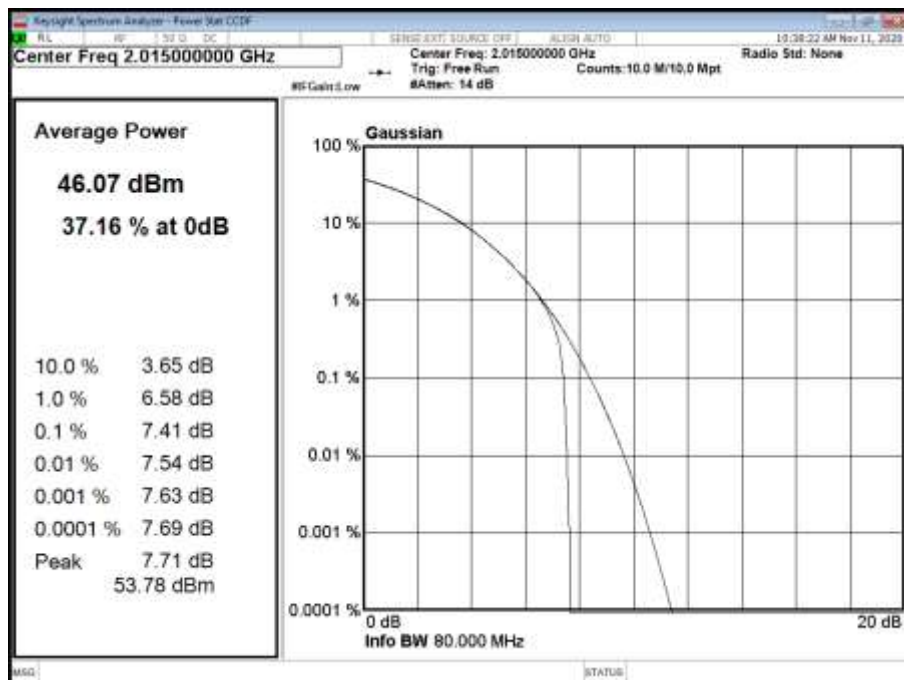



Antenna A - NR Modulation QPSK - NR Carrier Bandwidth 15.0 MHz 15 kHz SCS - Channel Position T

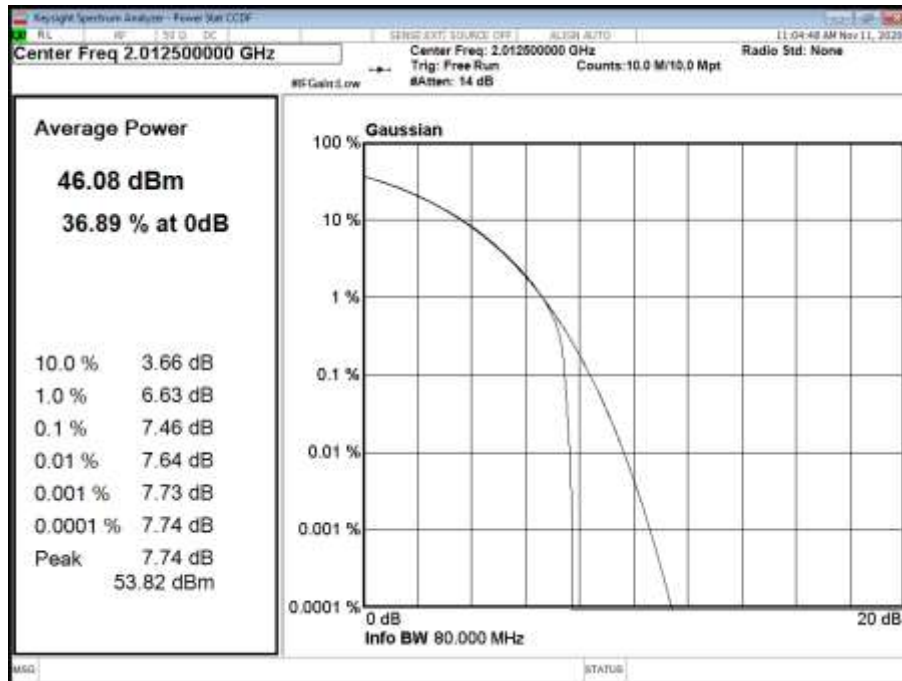

Antenna A - NR Modulation QPSK - NR Carrier Bandwidth 20.0 MHz 15 kHz SCS - Channel Position T

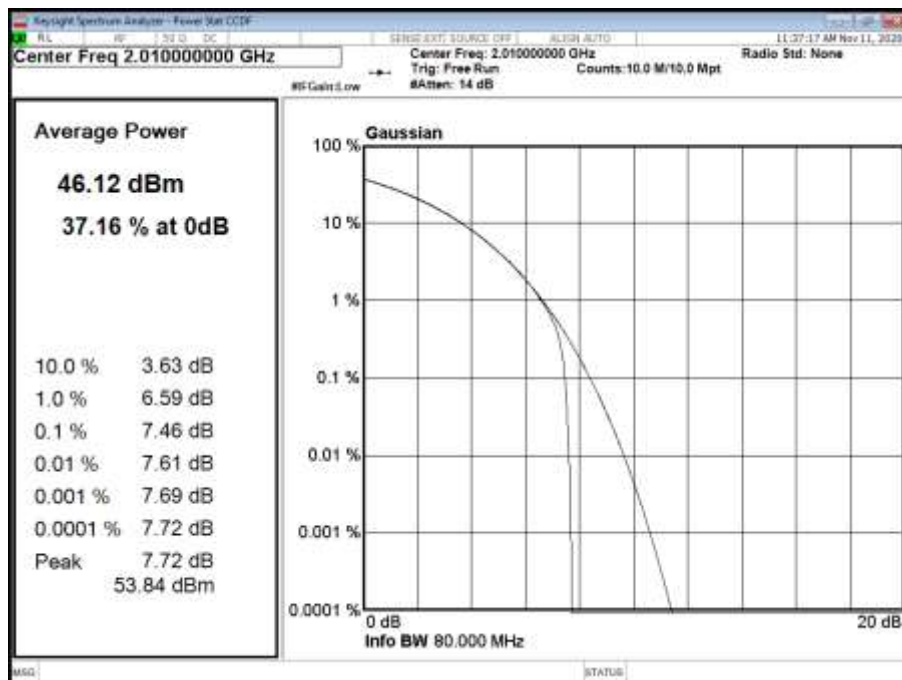



Limit	
Peak Power	$\leq 1640\text{ W}$ or $\leq +62.15\text{ dBm}$
Peak to Average Ratio	13 dB

The radio unit was tested with maximum output power and without an antenna. ERP/EIRP compliance is addressed at the time of licensing, as required by the responsible FCC/ISED Bureau(s). Licensees are required to take into account maximum allowed antenna gain used in combination with the above power settings to prevent the radiated output power exceeding the limits.



**2.2 OCCUPIED BANDWIDTH**

**2.2.1 Specification Reference**

FCC CFR 47 Part 2, Clause 2.1049  
 FCC CFR 47 Part 27, Clause 27.53

**2.2.2 Date of Test and Modification State**

11 November 2020 - Modification State 0

**2.2.3 Test Equipment Used**

The major items of test equipment used for the above tests are identified in Section 3.1.

**2.2.4 Environmental Conditions**

Ambient Temperature 23.5°C  
 Relative Humidity 51.3%

**2.2.5 Test Method**

All measurements were made in accordance with FCC KDB 971168 D01.

**2.2.6 Test Results**

Configuration A1

Maximum Output Power 46 dBm

Antenna	NR Modulation	NR Carrier Bandwidth	Result (KHz)					
			Channel Position B		Channel Position M		Channel Position T	
			Occupied Bandwidth	-26 dB Bandwidth	Occupied Bandwidth	-26 dB Bandwidth	Occupied Bandwidth	-26 dB Bandwidth
A	QPSK	5.0 MHz 15 kHz SCS	4,469.55	4,824.21	4,467.28	4,832.39	4,471.76	4,837.95
A	QPSK	10.0 MHz 15 kHz SCS	9,289.96	9,756.01	9,291.02	9,773.93	9,293.34	9,742.26
A	QPSK	15.0 MHz 15 kHz SCS	14,101.07	14,772.90	14,113.27	14,729.27	14,109.12	14,775.85
A	QPSK	20.0 MHz 15 kHz SCS	18,924.41	19,706.46	18,927.06	19,746.94	18,934.05	19,768.14



Antenna A - NR Modulation QPSK - NR Carrier Bandwidth 5.0 MHz 15 kHz SCS - Channel Position B

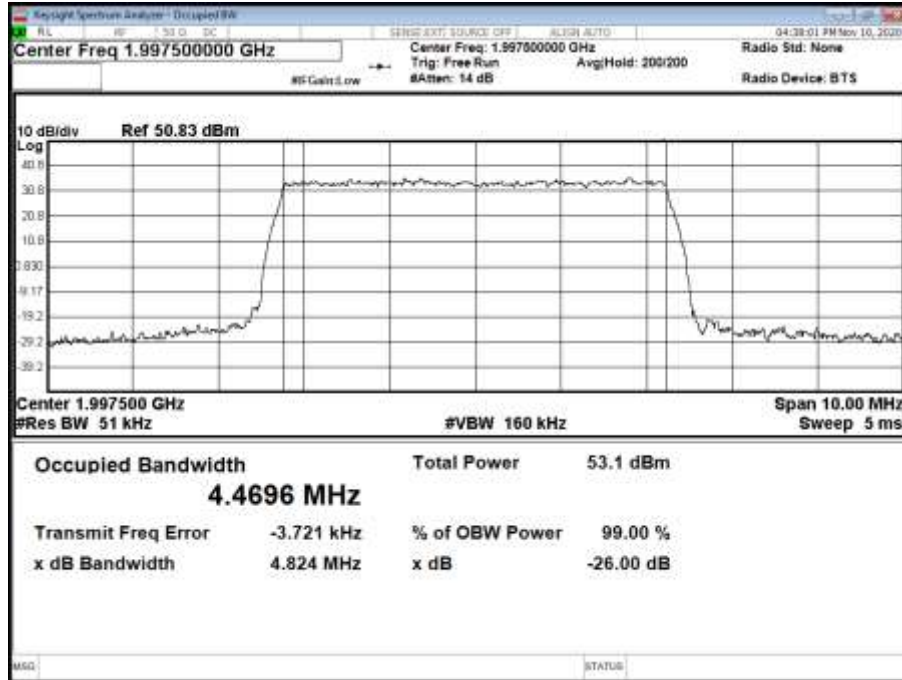

Antenna A - NR Modulation QPSK - NR Carrier Bandwidth 5.0 MHz 15 kHz SCS - Channel Position M

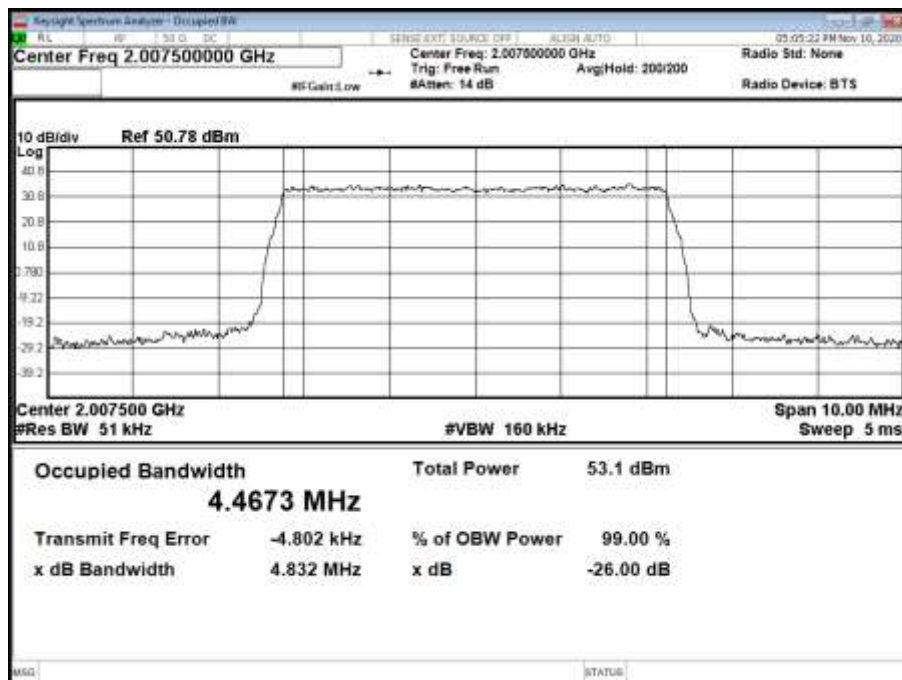



Antenna A - NR Modulation QPSK - NR Carrier Bandwidth 5.0 MHz 15 kHz SCS - Channel Position T

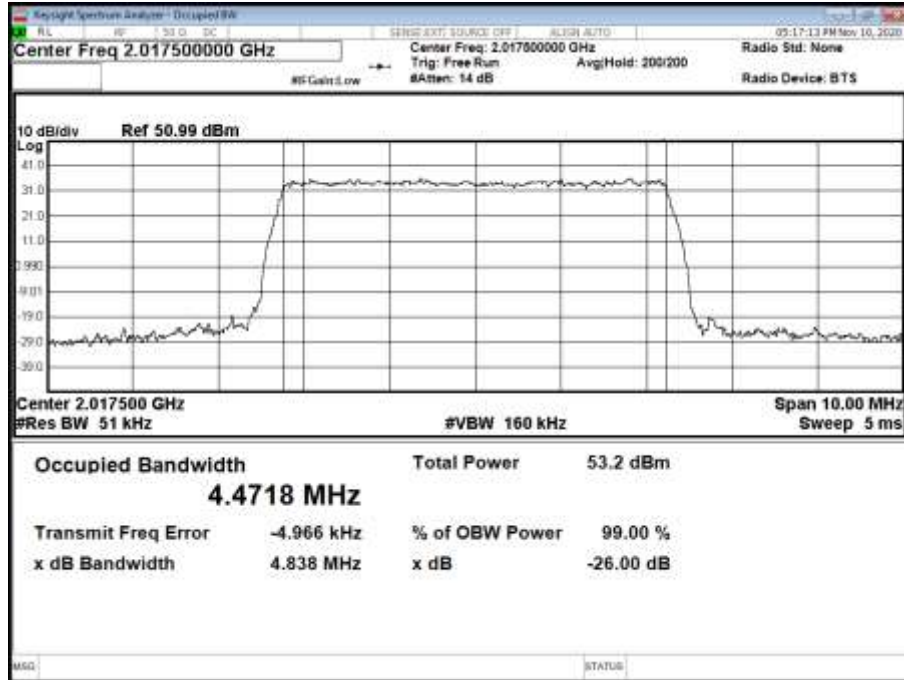

Antenna A - NR Modulation QPSK - NR Carrier Bandwidth 10.0 MHz 15 kHz SCS - Channel Position B

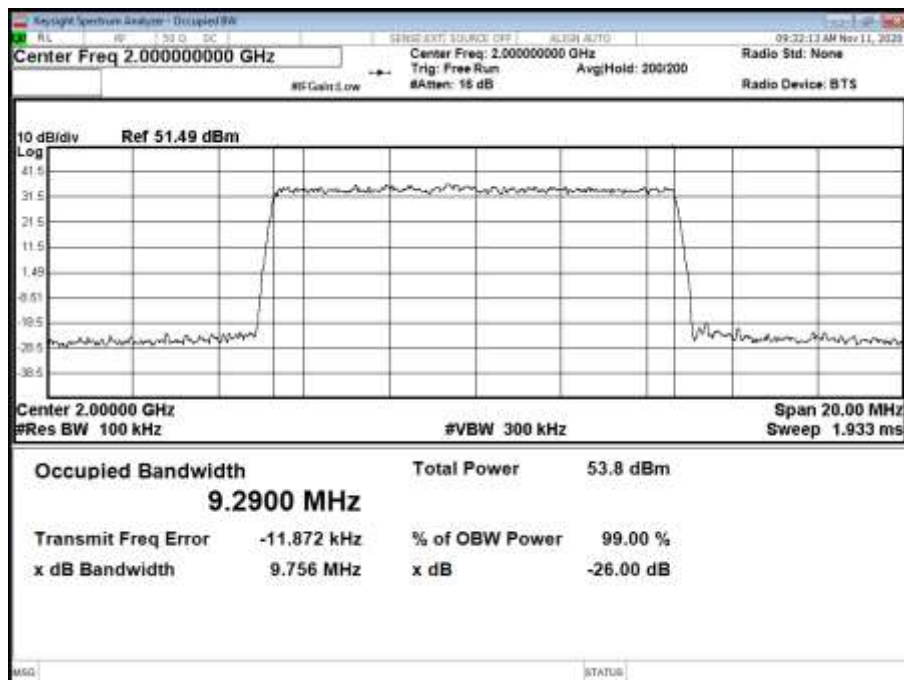



Antenna A - NR Modulation QPSK - NR Carrier Bandwidth 10.0 MHz 15 kHz SCS - Channel Position M

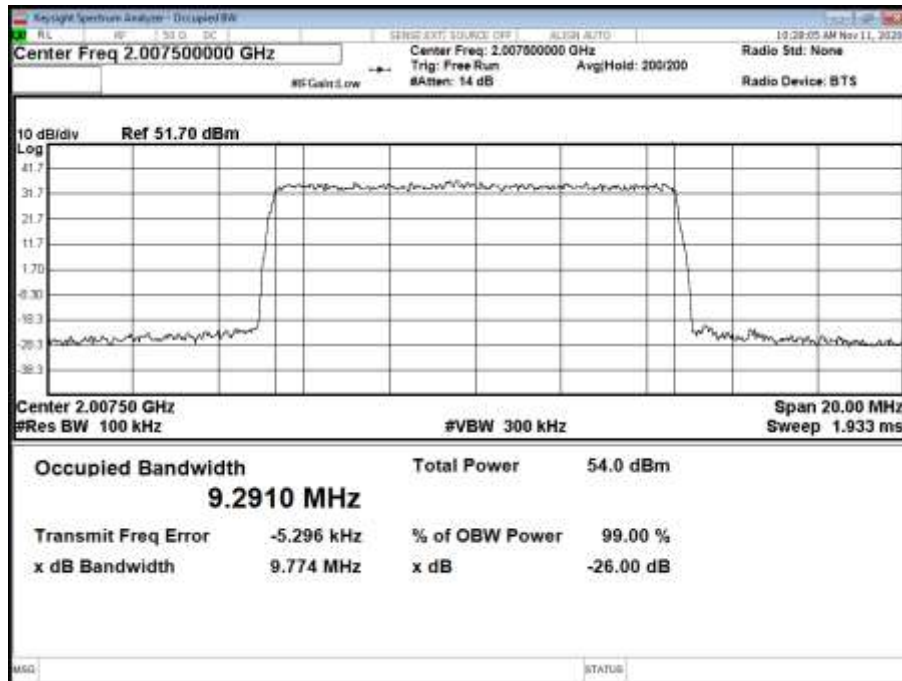

Antenna A - NR Modulation QPSK - NR Carrier Bandwidth 10.0 MHz 15 kHz SCS - Channel Position T

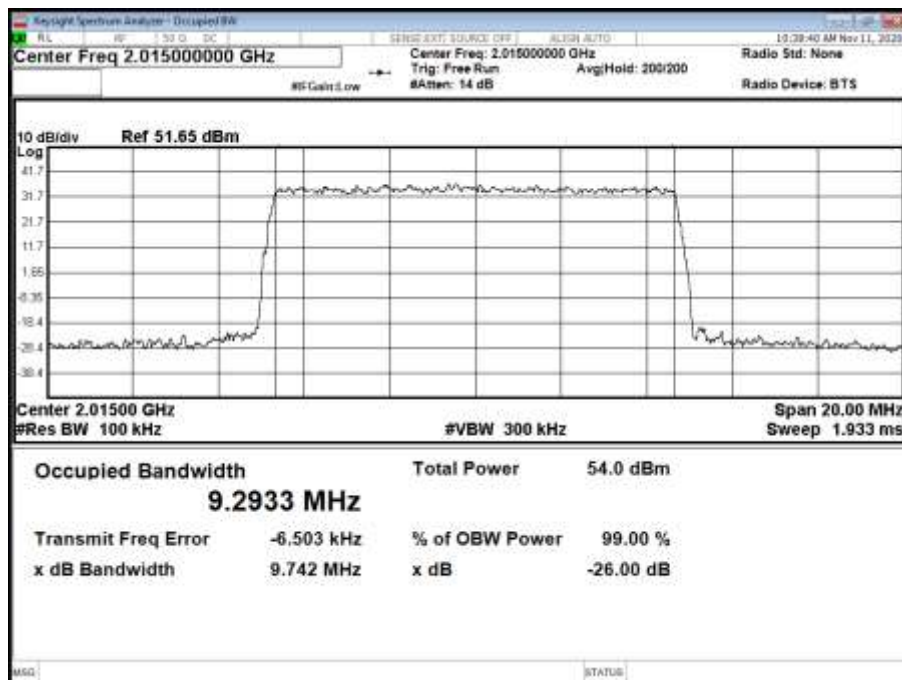





Antenna A - NR Modulation QPSK - NR Carrier Bandwidth 15.0 MHz 15 kHz SCS - Channel Position B

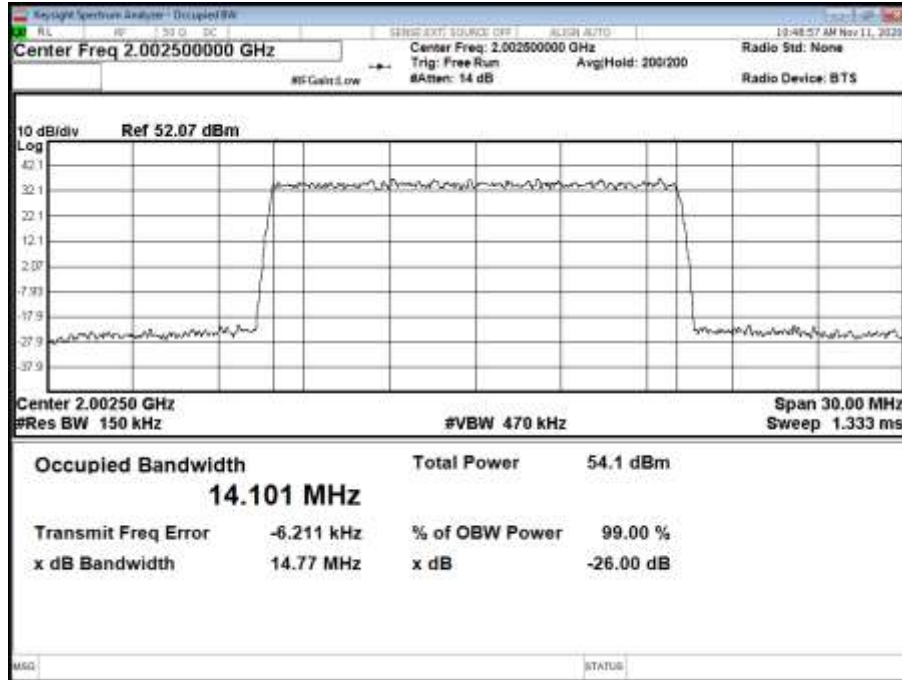

Antenna A - NR Modulation QPSK - NR Carrier Bandwidth 15.0 MHz 15 kHz SCS - Channel Position M

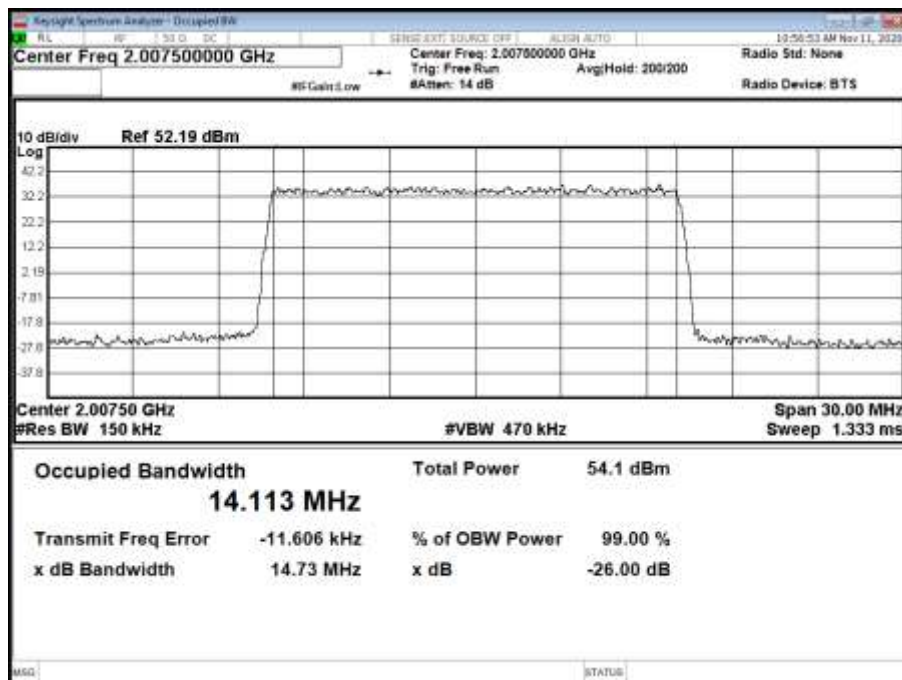



Antenna A - NR Modulation QPSK - NR Carrier Bandwidth 15.0 MHz 15 kHz SCS - Channel Position T

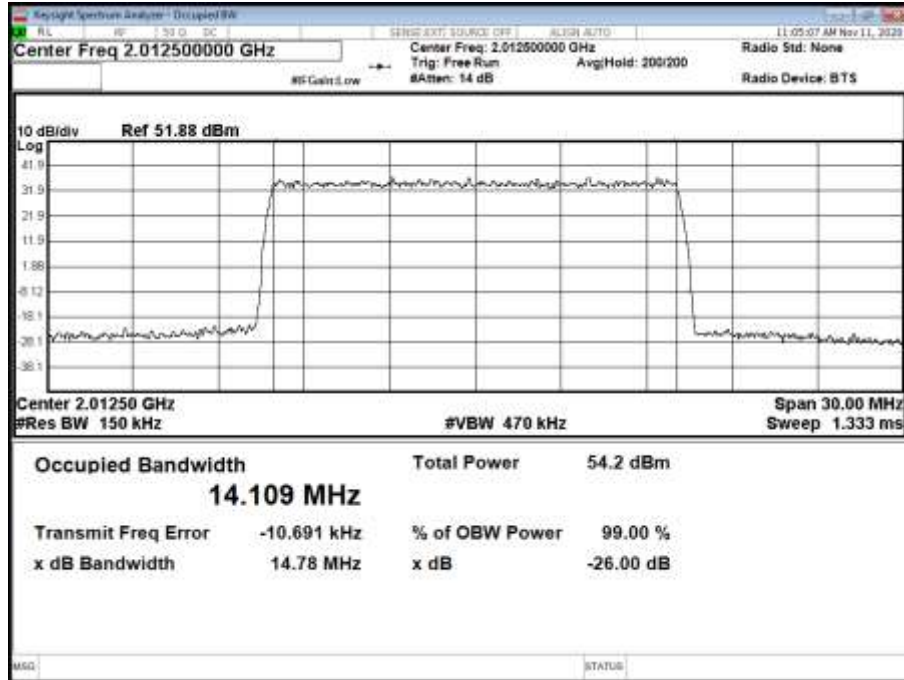

Antenna A - NR Modulation QPSK - NR Carrier Bandwidth 20.0 MHz 15 kHz SCS - Channel Position B

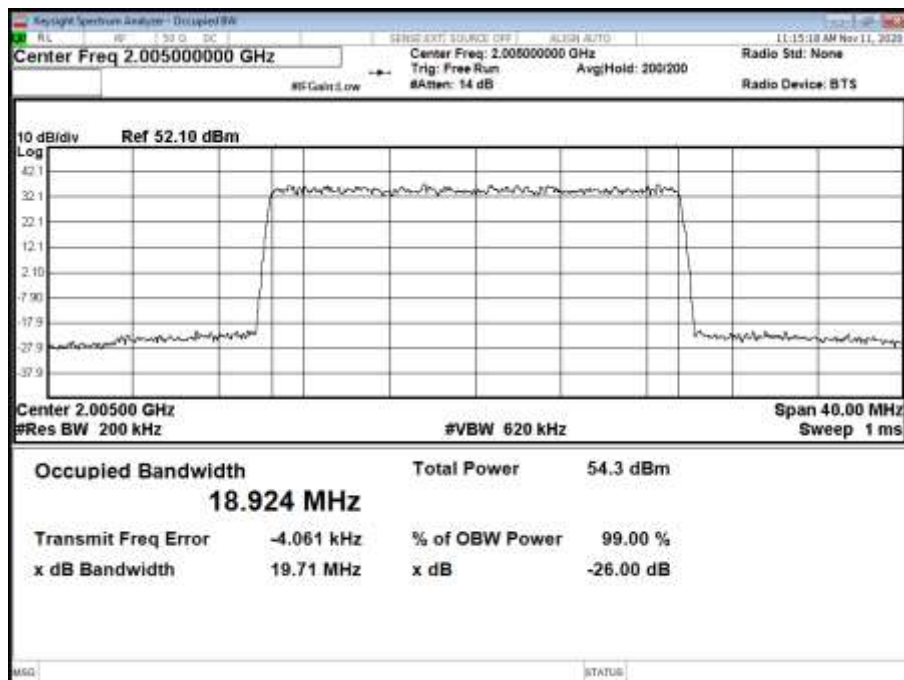



Antenna A - NR Modulation QPSK - NR Carrier Bandwidth 20.0 MHz 15 kHz SCS - Channel Position M

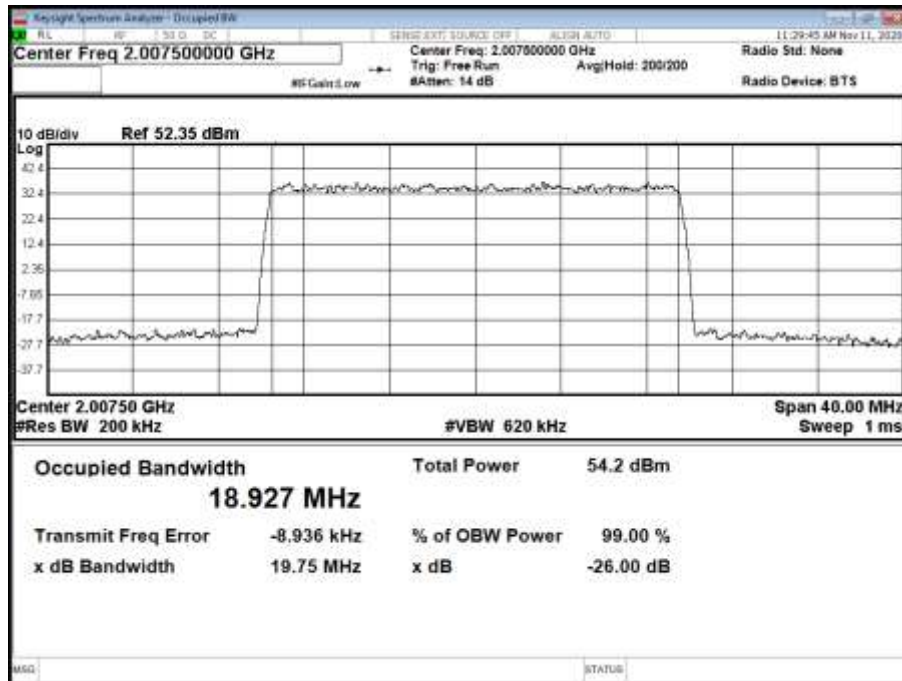

Antenna A - NR Modulation QPSK - NR Carrier Bandwidth 20.0 MHz 15 kHz SCS - Channel Position T

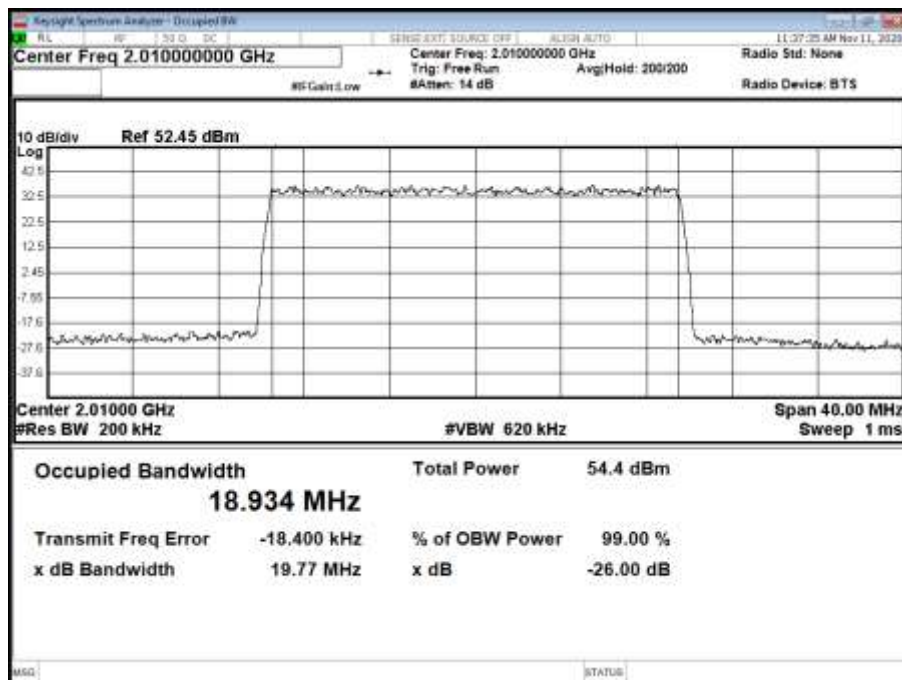



## 2.3 BAND EDGE

### 2.3.1 Specification Reference

FCC CFR 47 Part 2, Clause 2.1051  
FCC CFR 47 Part 27, Clause 27.53 (h)

### 2.3.2 Date of Test and Modification State

11 November 2020 - Modification State 0

### 2.3.3 Test Equipment Used

The major items of test equipment used for the above tests are identified in Section 3.1.

### 2.3.4 Environmental Conditions

Ambient Temperature 23.5°C  
Relative Humidity 51.3%

### 2.3.5 Test Method

All measurements were made in accordance with FCC KDB 971168 D01.

Each antenna port has been declared as being equivalent, therefore measurements were made on one antenna port only. To account for this, the limit was tightened by  $10 * \text{Log}(N)$ , where N is equal to the number of MIMO antenna ports.

For four port, the limit was calculated as being  $-13 \text{ dBm} - 10 * \text{Log}(4) = -19 \text{ dBm}$ .

### 2.3.6 Test Results

Configuration A1

Maximum Output Power 46 dBm

Antenna	NR Modulation	NR Carrier Bandwidth	Band Edge (MHz)	
			Channel Position B	Channel Position T
A	QPSK	5.0 MHz 15 kHz SCS	1,997.5	2,017.5
A	QPSK	10.0 MHz 15 kHz SCS	2,000.0	2,015.0
A	QPSK	15.0 MHz 15 kHz SCS	2,002.5	2,012.5
A	QPSK	20.0 MHz 15 kHz SCS	2,005.0	2,010.0



Antenna A - NR Modulation QPSK - NR Carrier Bandwidth 5.0 MHz 15 kHz SCS - Channel Position B

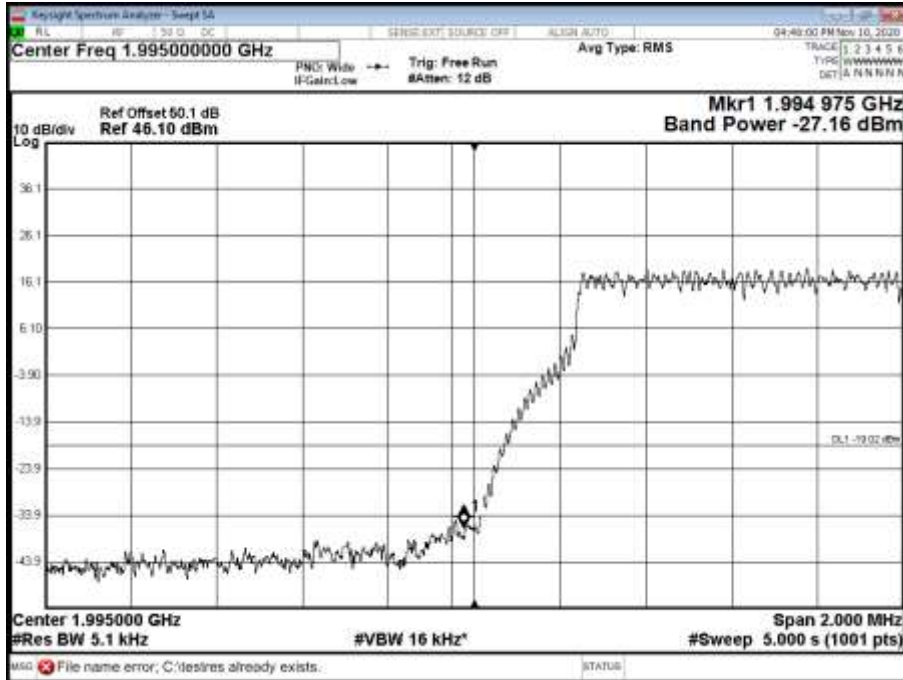

Antenna A - NR Modulation QPSK - NR Carrier Bandwidth 5.0 MHz 15 kHz SCS - Channel Position T

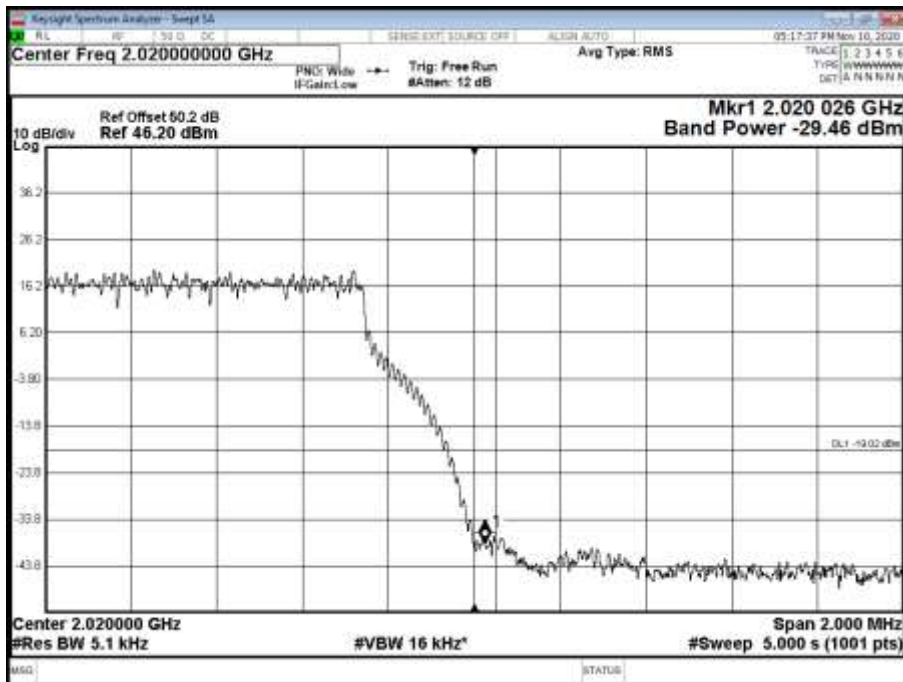



Antenna A - NR Modulation QPSK - NR Carrier Bandwidth 10.0 MHz 15 kHz SCS - Channel Position B

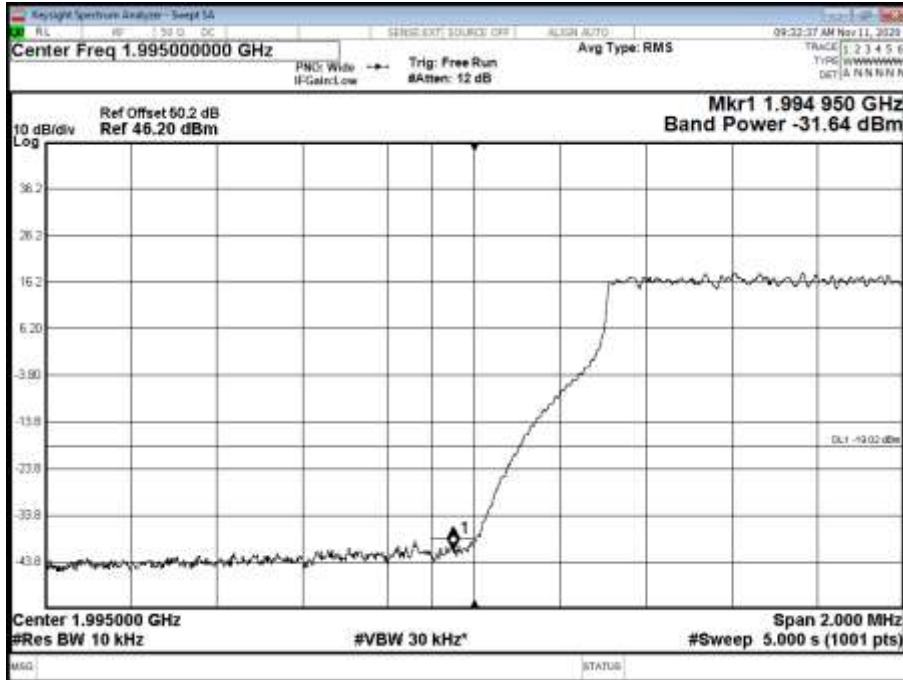

Antenna A - NR Modulation QPSK - NR Carrier Bandwidth 10.0 MHz 15 kHz SCS - Channel Position T

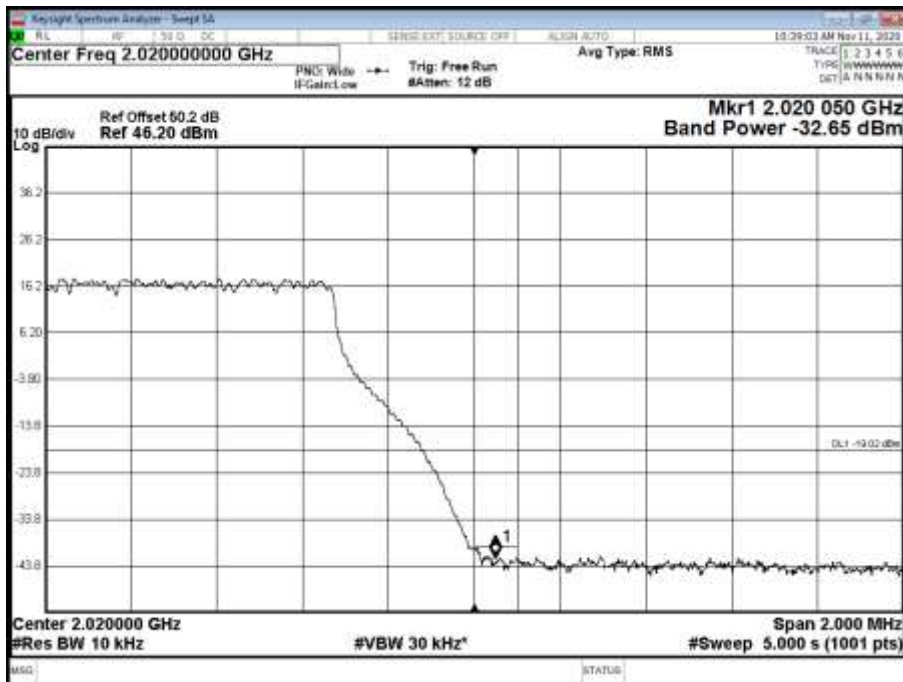



Antenna A - NR Modulation QPSK - NR Carrier Bandwidth 15.0 MHz 15 kHz SCS - Channel Position B

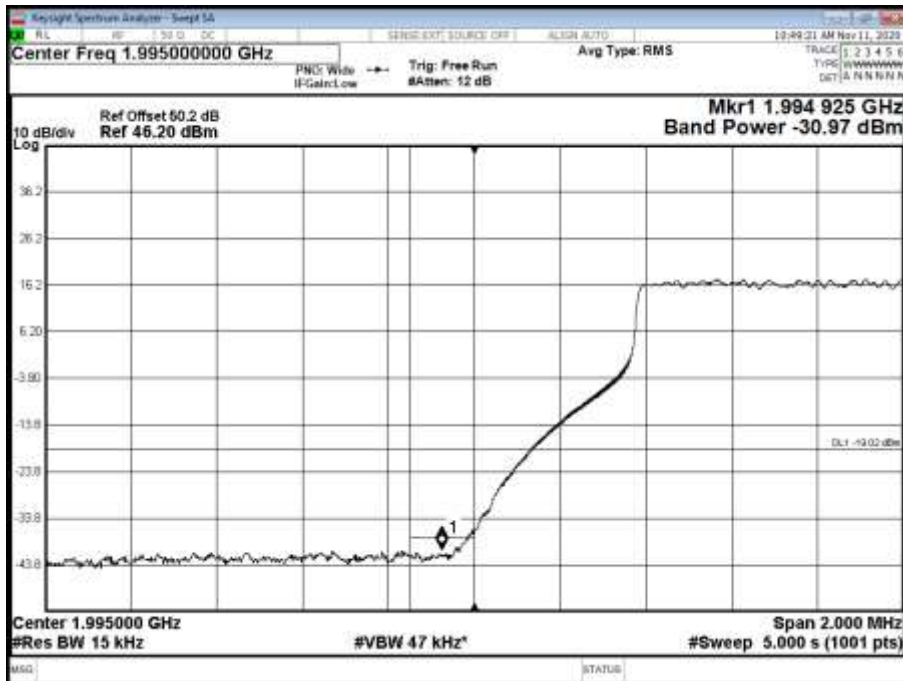

Antenna A - NR Modulation QPSK - NR Carrier Bandwidth 15.0 MHz 15 kHz SCS - Channel Position T

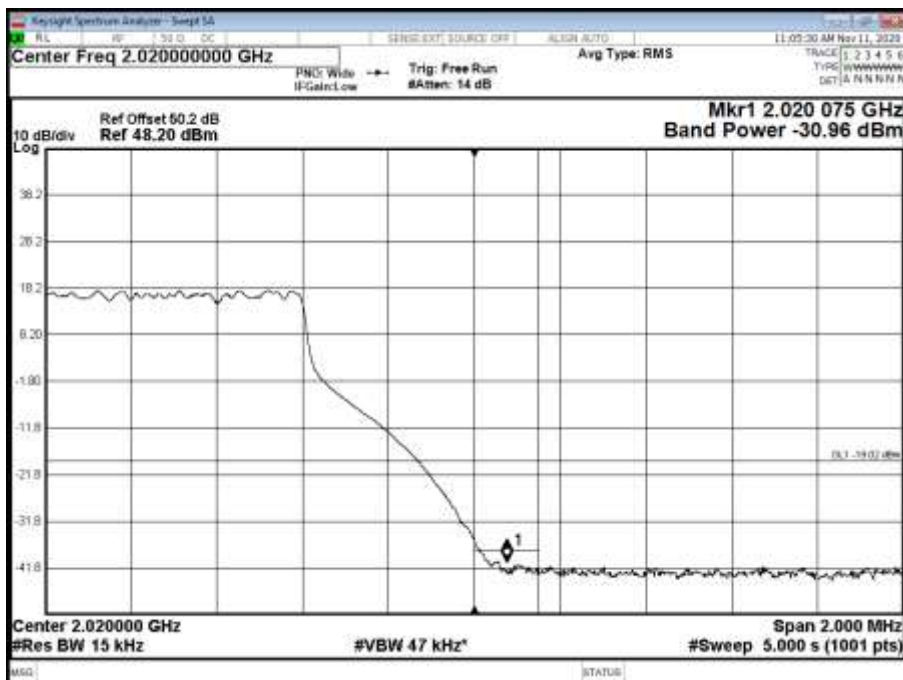



Antenna A - NR Modulation QPSK - NR Carrier Bandwidth 20.0 MHz 15 kHz SCS - Channel Position B

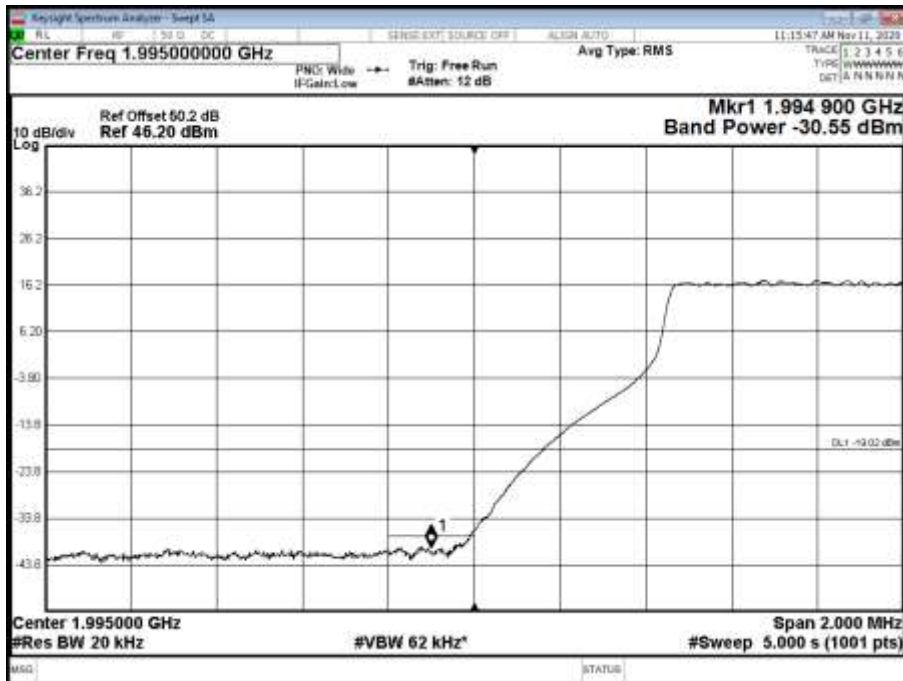

Antenna A - NR Modulation QPSK - NR Carrier Bandwidth 20.0 MHz 15 kHz SCS - Channel Position T

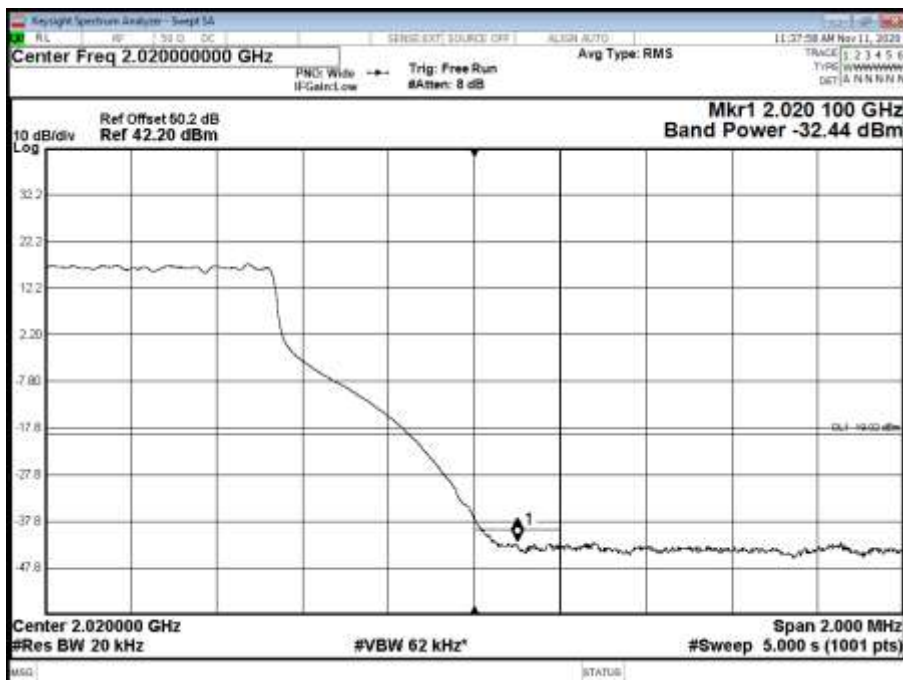





Limit	
Peak Power	$\leq 1640$ W/MHz or $\leq +62.15$ dBm
Peak to Average Ratio	13 dB

Limit	-19 dBm
-------	---------



## **2.4 TRANSMITTER SPURIOUS EMISSIONS**

### **2.4.1 Specification Reference**

FCC CFR 47 Part 2, Clause 2.1051  
FCC CFR 47 Part 27, Clause 27.53 (h)

### **2.4.2 Date of Test and Modification State**

11 November 2020 - Modification State 0

### **2.4.3 Test Equipment Used**

The major items of test equipment used for the above tests are identified in Section 3.1.

### **2.4.4 Environmental Conditions**

Ambient Temperature	23.5°C
Relative Humidity	51.3%

### **2.4.5 Test Method**

All measurements were made in accordance with FCC KDB 971168 D01.

Each antenna port has been declared as being equivalent, therefore measurements were made on one antenna port only. To account for this, the limit was tightened by  $10 * \text{Log}(N)$ , where N is equal to the number of MIMO antenna ports.

For four port, the limit was calculated as being  $-13 \text{ dBm} - 10 * \text{Log}(4) = -19 \text{ dBm}$ .

### **2.4.6 Test Results**

Configuration A1

Maximum Output Power 46 dBm



Antenna A - NR Modulation QPSK - NR Carrier Bandwidth 5.0 MHz 15 kHz SCS - Channel Position B - Band 1 - Range 0.009 to 3500 MHz

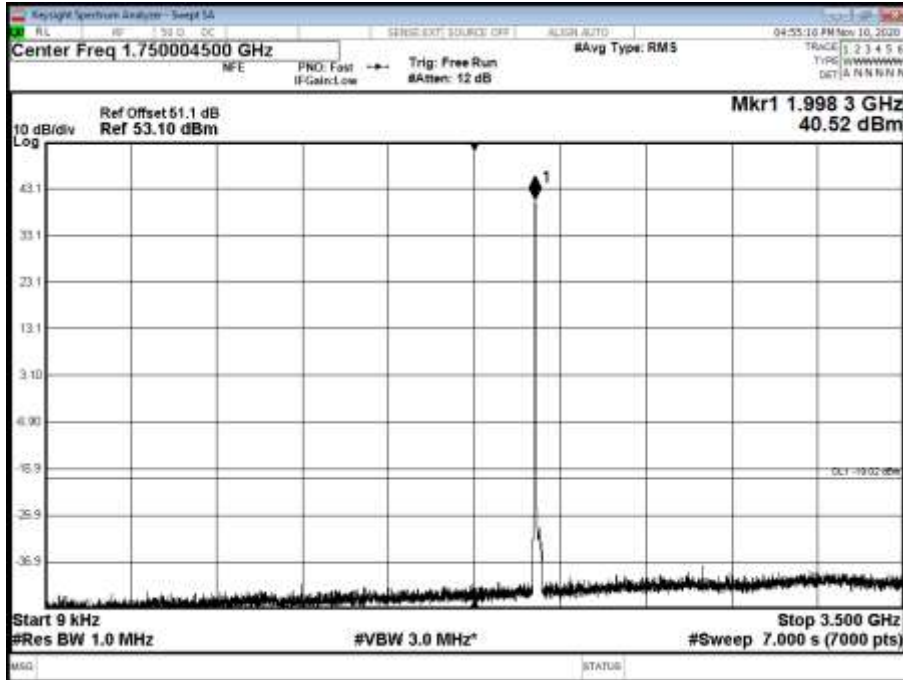

Antenna A - NR Modulation QPSK - NR Carrier Bandwidth 5.0 MHz 15 kHz SCS - Channel Position B - Band 2 - Range 3500 to 8000 MHz

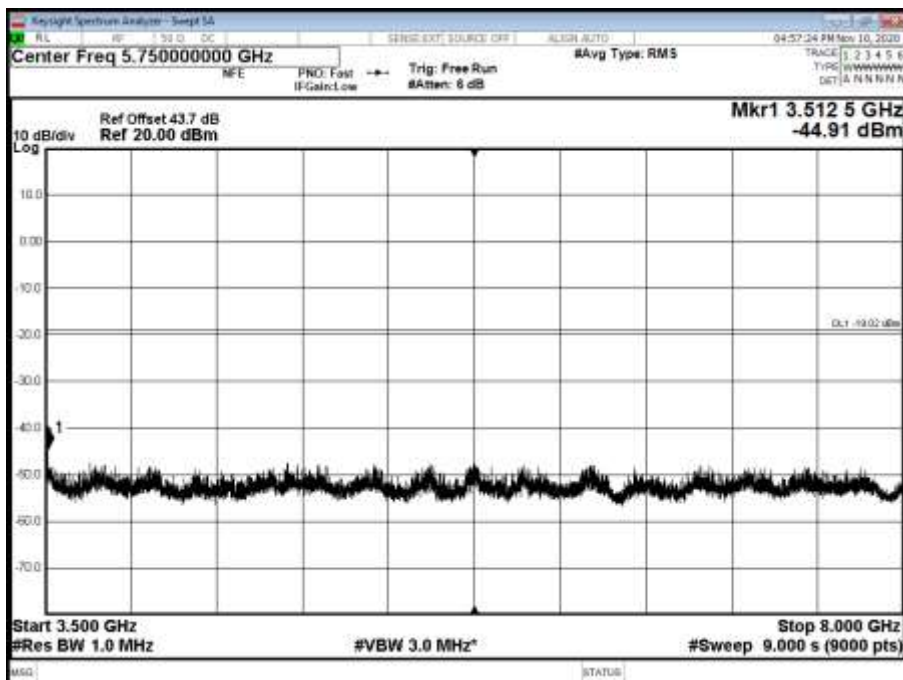



Antenna A - NR Modulation QPSK - NR Carrier Bandwidth 5.0 MHz 15 kHz SCS - Channel Position B - Band 3 - Range 8000 to 12000 MHz

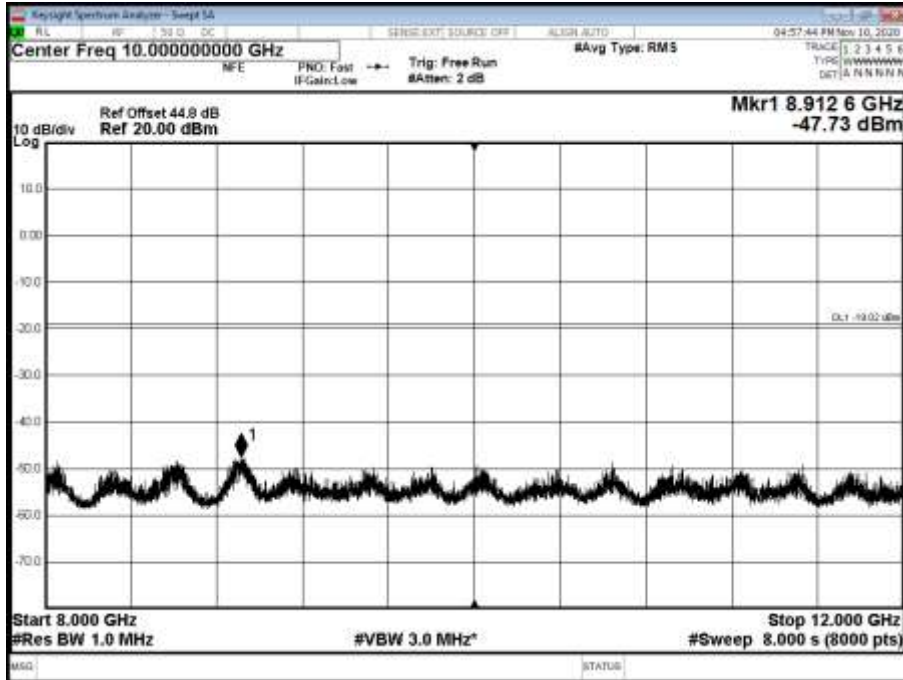

Antenna A - NR Modulation QPSK - NR Carrier Bandwidth 5.0 MHz 15 kHz SCS - Channel Position B - Band 4 - Range 12000 to 18000 MHz

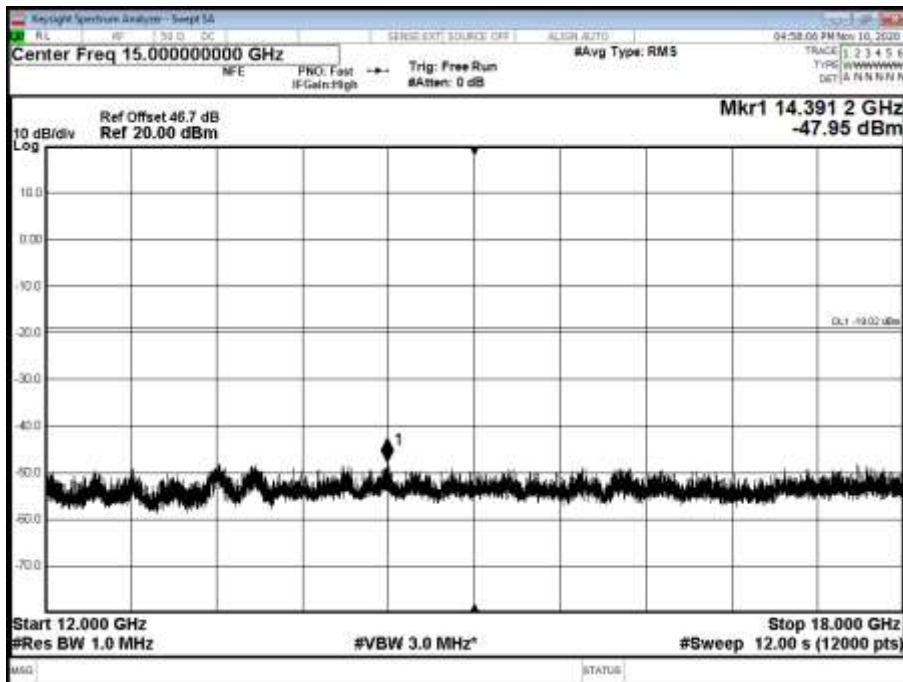



Antenna A - NR Modulation QPSK - NR Carrier Bandwidth 5.0 MHz 15 kHz SCS - Channel Position B - Band 5 - Range 18000 to 21000 MHz

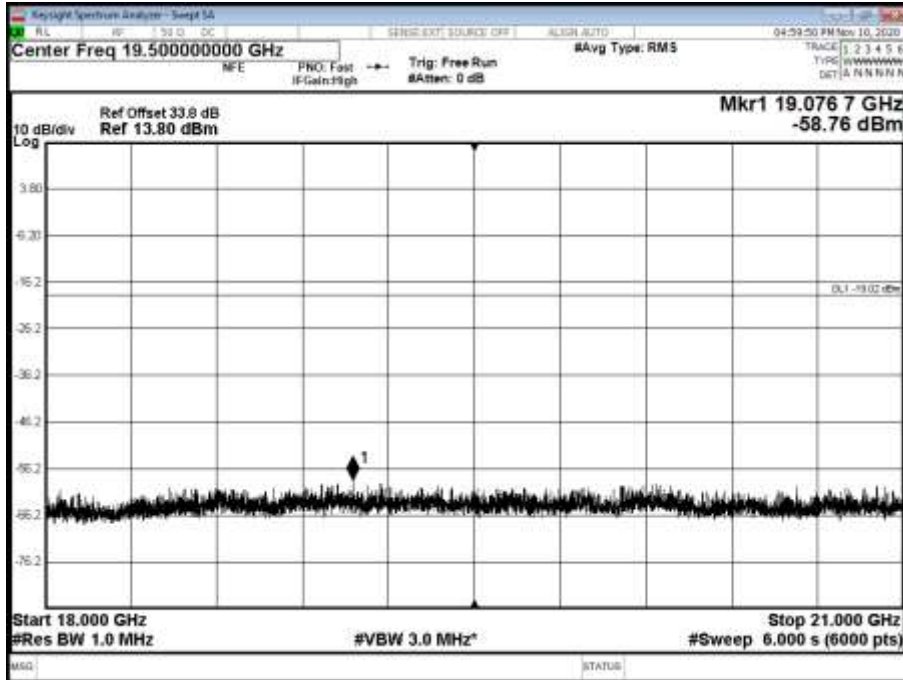

Antenna A - NR Modulation QPSK - NR Carrier Bandwidth 5.0 MHz 15 kHz SCS - Channel Position M - Band 1 - Range 0.009 to 3500 MHz

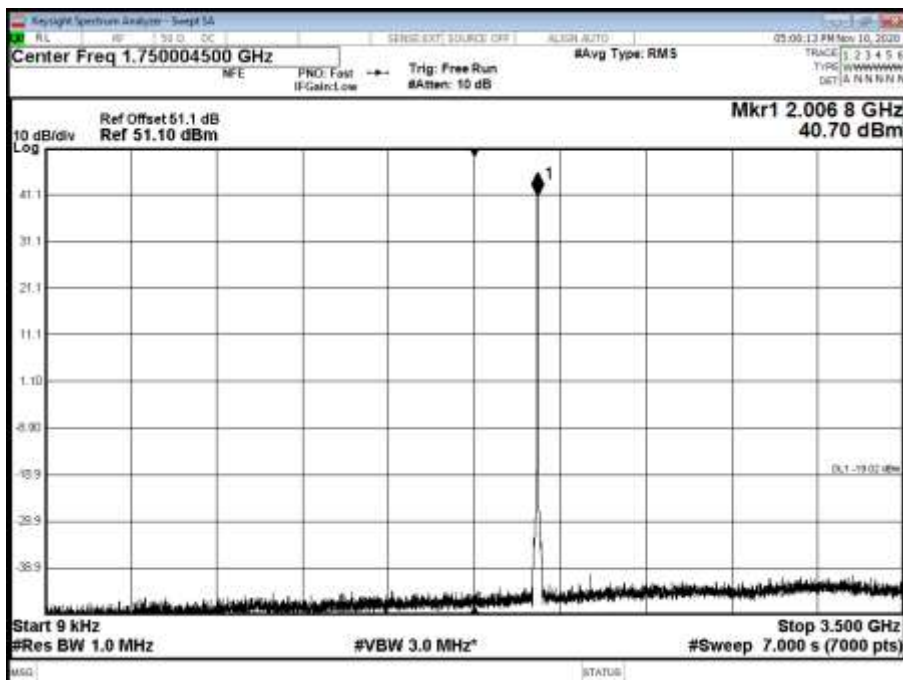



Antenna A - NR Modulation QPSK - NR Carrier Bandwidth 5.0 MHz 15 kHz SCS - Channel Position M - Band 2 - Range 3500 to 8000 MHz

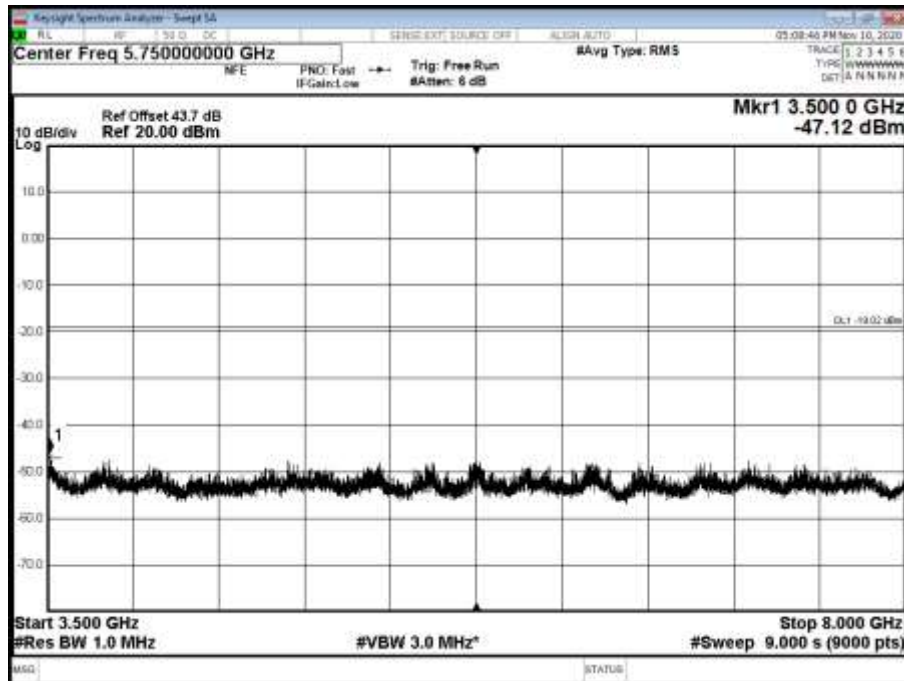

Antenna A - NR Modulation QPSK - NR Carrier Bandwidth 5.0 MHz 15 kHz SCS - Channel Position M - Band 3 - Range 8000 to 12000 MHz

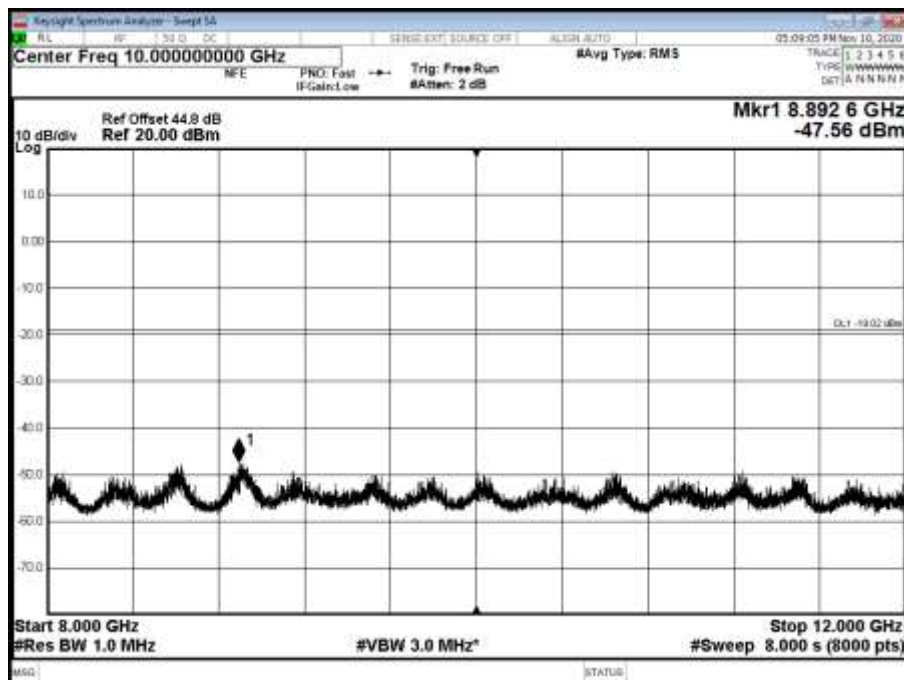



Antenna A - NR Modulation QPSK - NR Carrier Bandwidth 5.0 MHz 15 kHz SCS - Channel Position M - Band 4 - Range 12000 to 18000 MHz

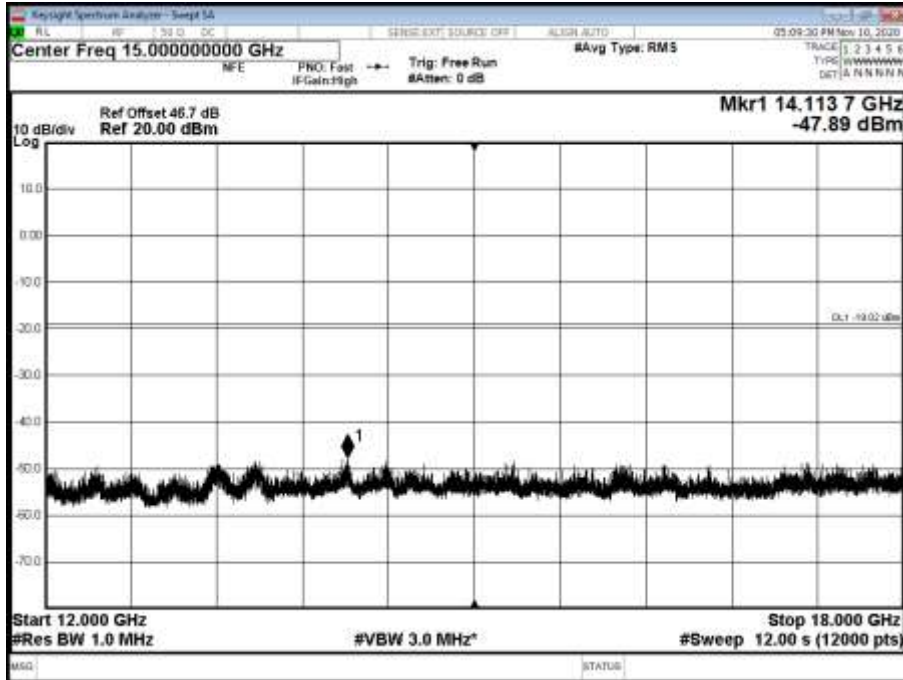

Antenna A - NR Modulation QPSK - NR Carrier Bandwidth 5.0 MHz 15 kHz SCS - Channel Position M - Band 5 - Range 18000 to 21000 MHz

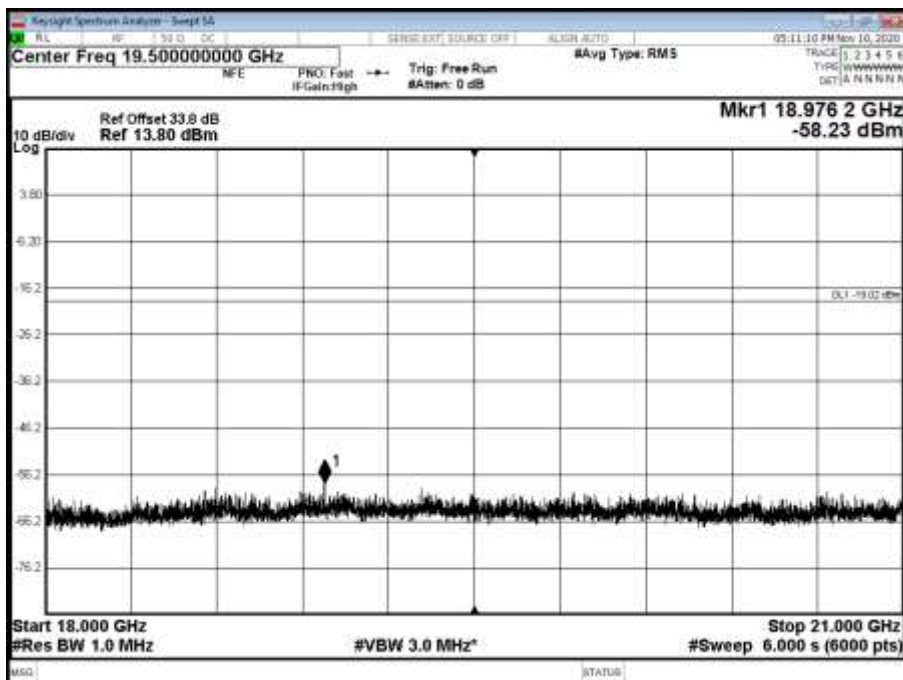



Antenna A - NR Modulation QPSK - NR Carrier Bandwidth 5.0 MHz 15 kHz SCS - Channel Position T - Band 1 - Range 0.009 to 3500 MHz

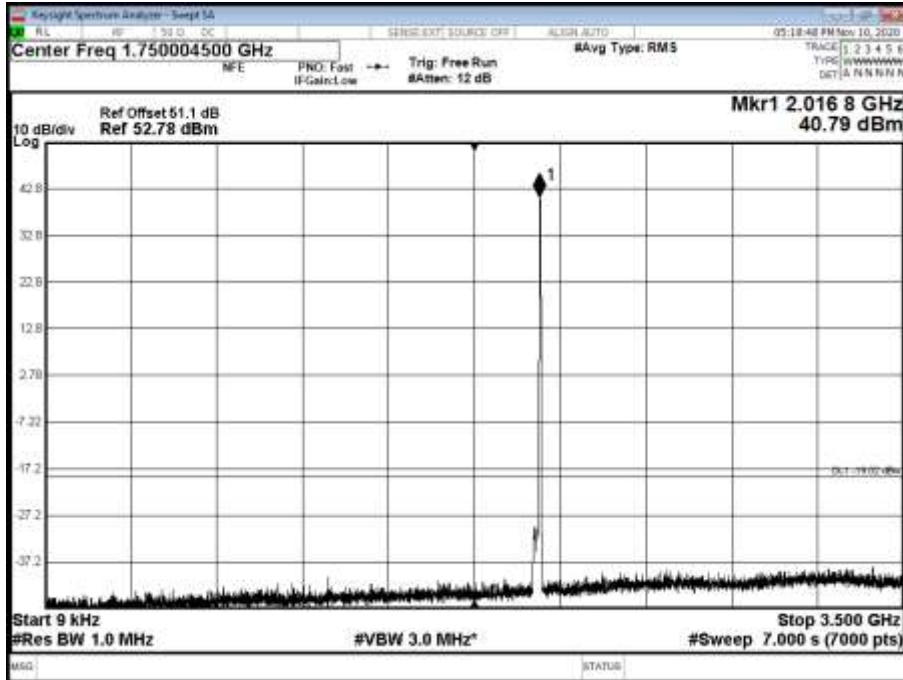

Antenna A - NR Modulation QPSK - NR Carrier Bandwidth 5.0 MHz 15 kHz SCS - Channel Position T - Band 2 - Range 3500 to 8000 MHz

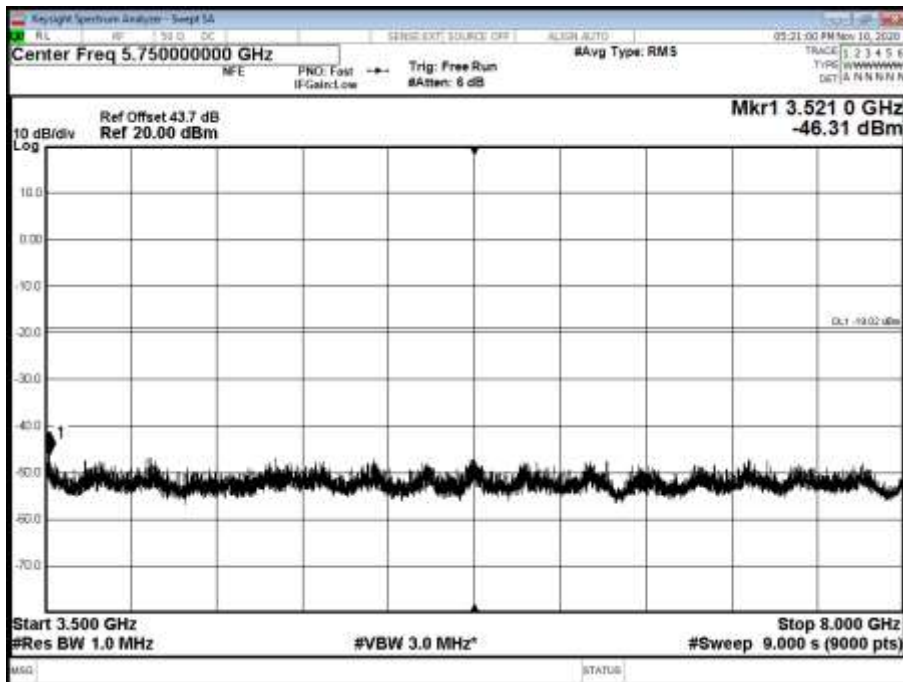





Antenna A - NR Modulation QPSK - NR Carrier Bandwidth 5.0 MHz 15 kHz SCS - Channel Position T - Band 3 - Range 8000 to 12000 MHz

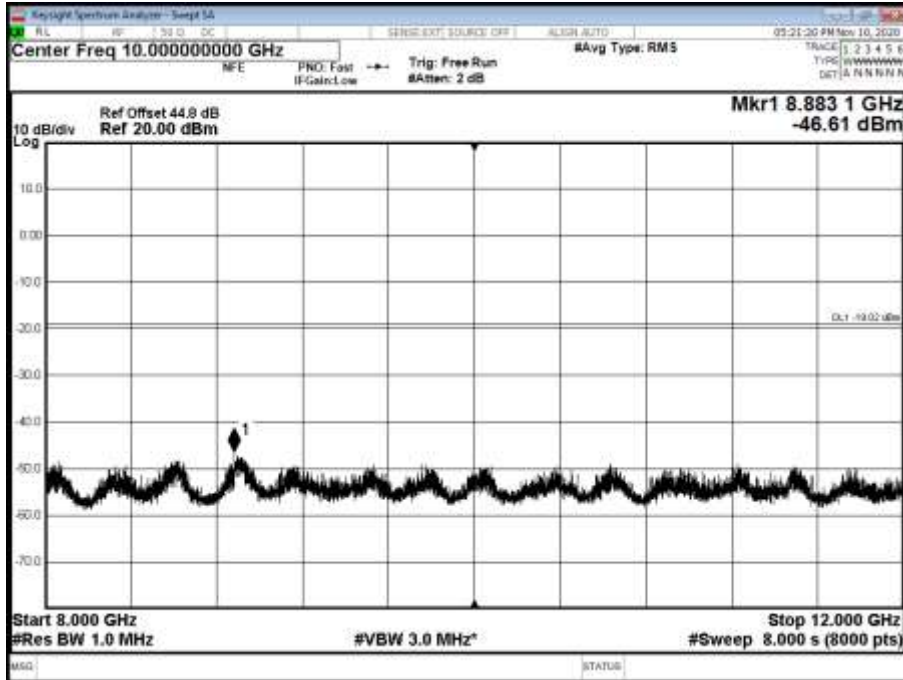

Antenna A - NR Modulation QPSK - NR Carrier Bandwidth 5.0 MHz 15 kHz SCS - Channel Position T - Band 4 - Range 12000 to 18000 MHz

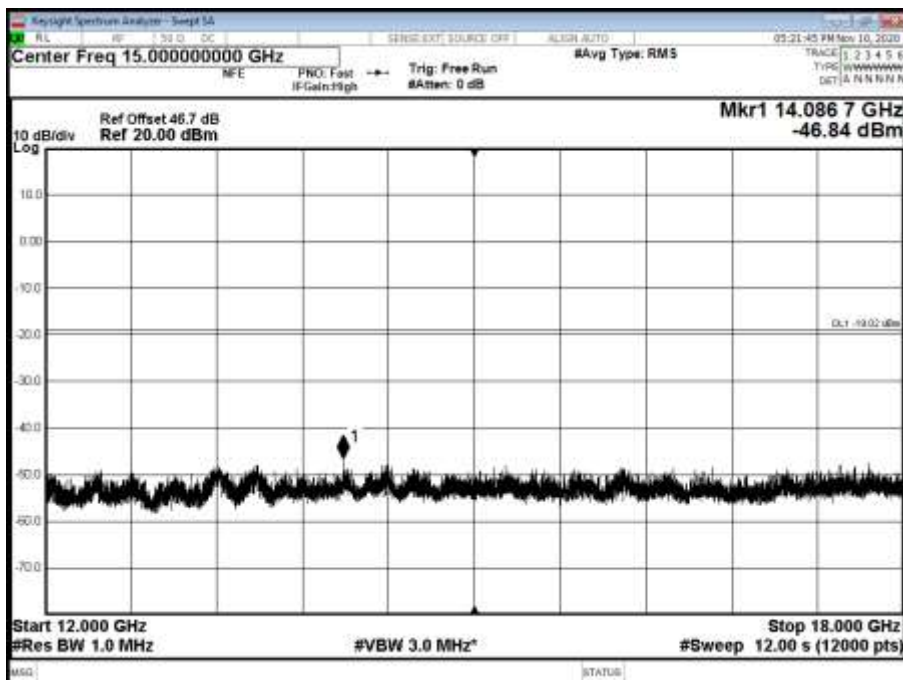



Antenna A - NR Modulation QPSK - NR Carrier Bandwidth 5.0 MHz 15 kHz SCS - Channel Position T - Band 5 - Range 18000 to 21000 MHz

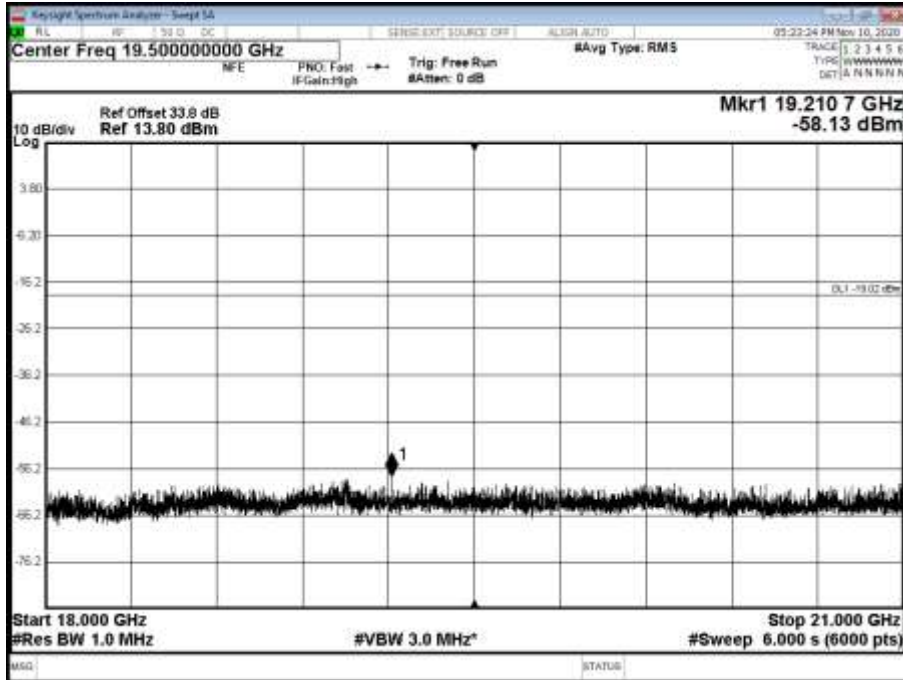

Antenna A - NR Modulation QPSK - NR Carrier Bandwidth 10.0 MHz 15 kHz SCS - Channel Position B - Band 1 - Range 0.009 to 3500 MHz

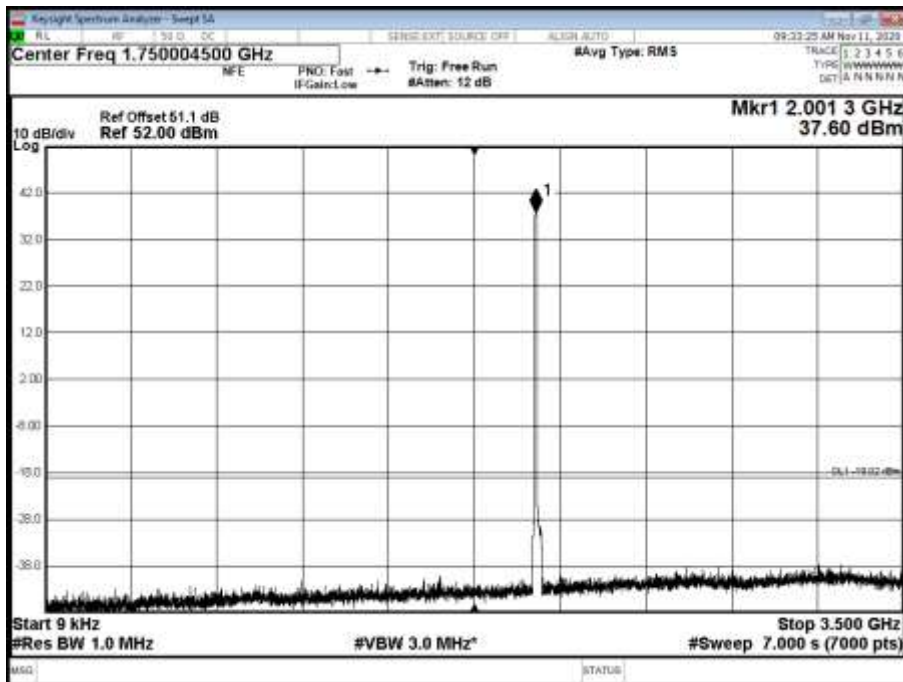



Antenna A - NR Modulation QPSK - NR Carrier Bandwidth 10.0 MHz 15 kHz SCS - Channel Position B - Band 2 - Range 3500 to 8000 MHz

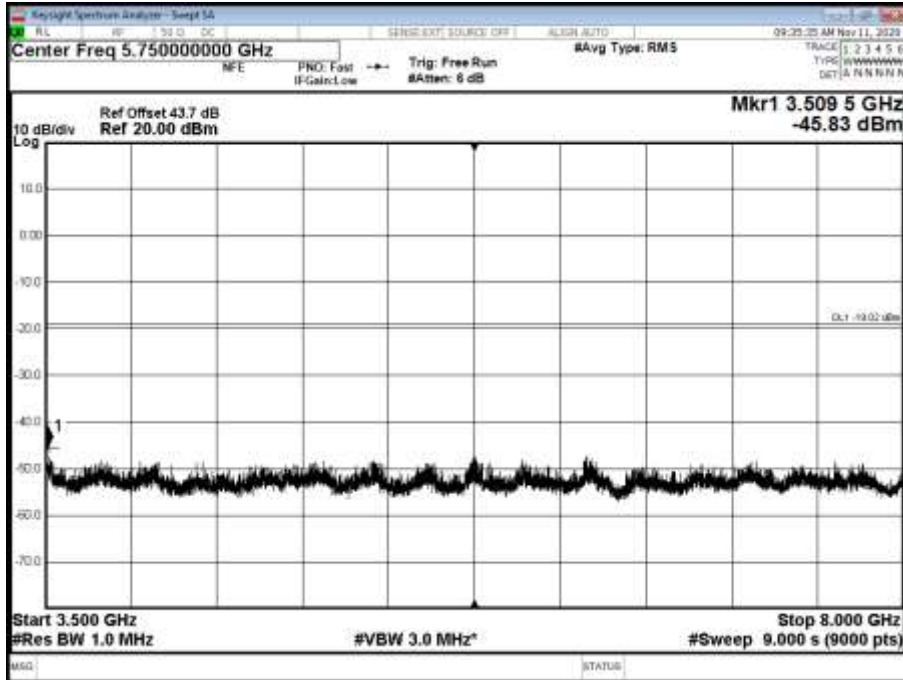

Antenna A - NR Modulation QPSK - NR Carrier Bandwidth 10.0 MHz 15 kHz SCS - Channel Position B - Band 3 - Range 8000 to 12000 MHz

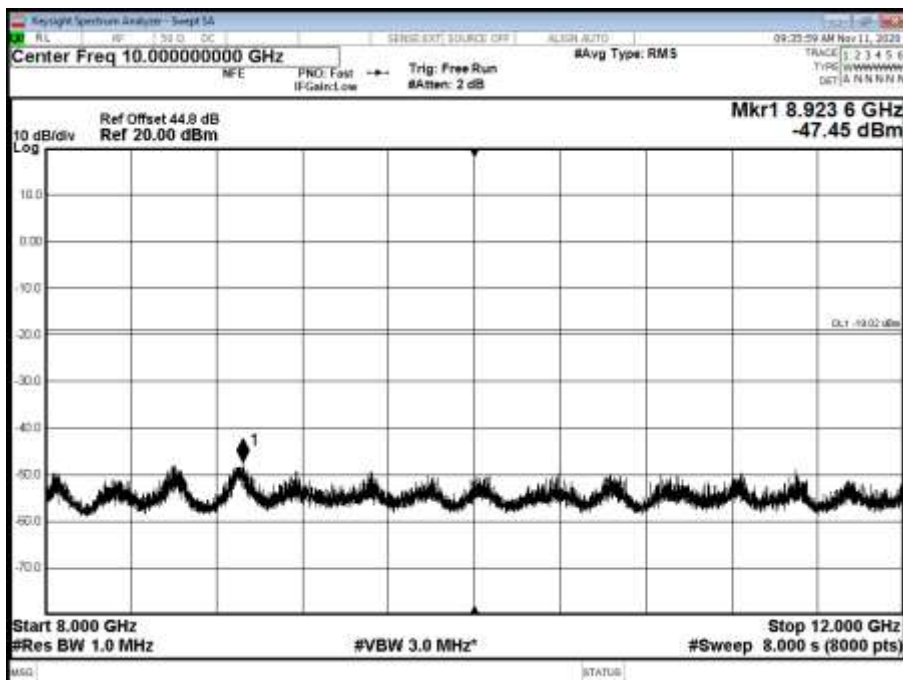



Antenna A - NR Modulation QPSK - NR Carrier Bandwidth 10.0 MHz 15 kHz SCS - Channel Position B - Band 4 - Range 12000 to 18000 MHz

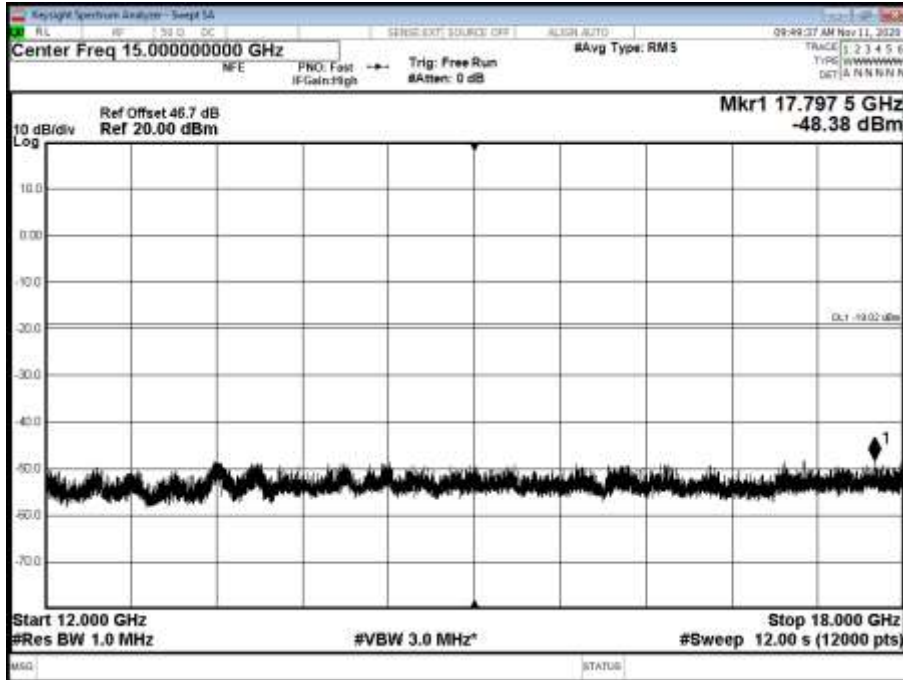

Antenna A - NR Modulation QPSK - NR Carrier Bandwidth 10.0 MHz 15 kHz SCS - Channel Position B - Band 5 - Range 18000 to 21000 MHz

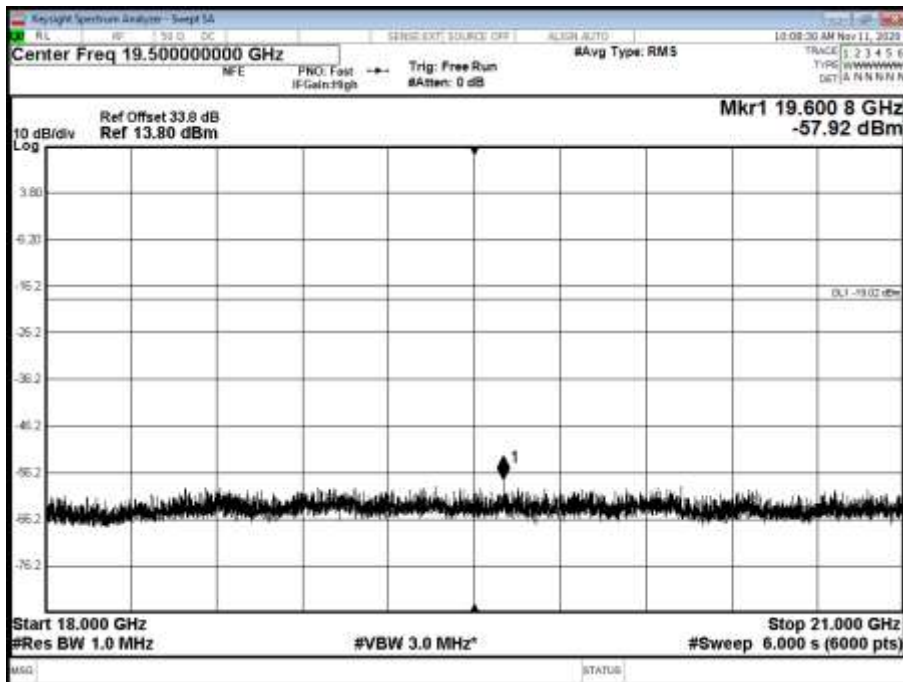



Antenna A - NR Modulation QPSK - NR Carrier Bandwidth 10.0 MHz 15 kHz SCS - Channel Position M - Band 1 - Range 0.009 to 3500 MHz

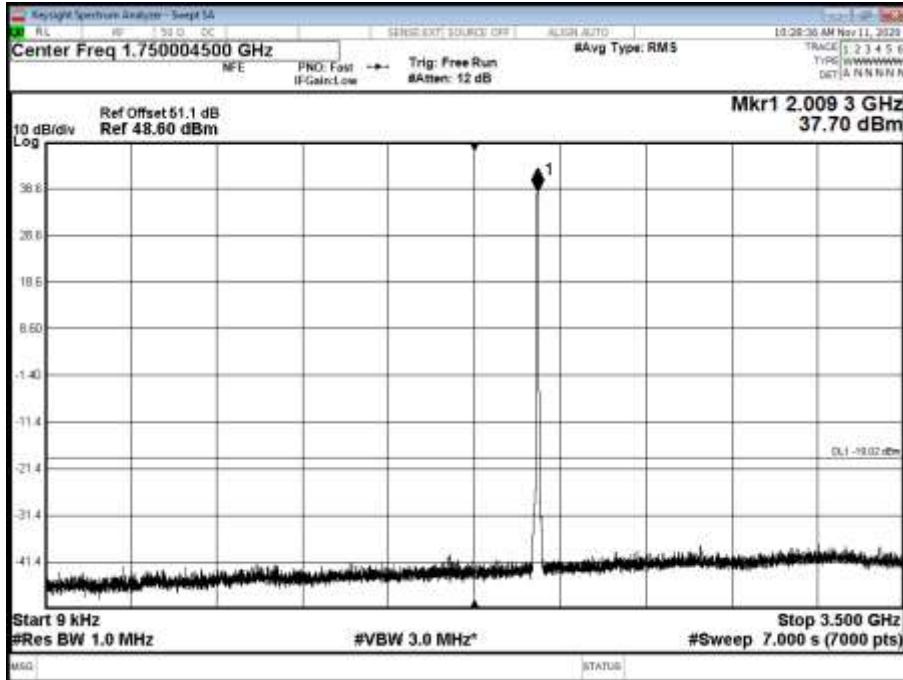

Antenna A - NR Modulation QPSK - NR Carrier Bandwidth 10.0 MHz 15 kHz SCS - Channel Position M - Band 2 - Range 3500 to 8000 MHz

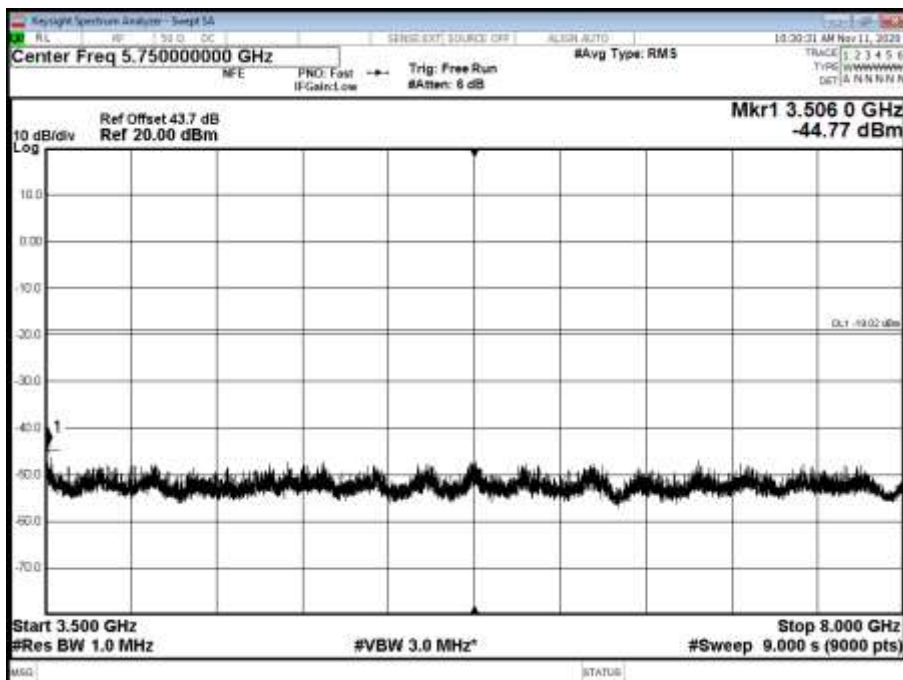



Antenna A - NR Modulation QPSK - NR Carrier Bandwidth 10.0 MHz 15 kHz SCS - Channel Position M - Band 3 - Range 8000 to 12000 MHz

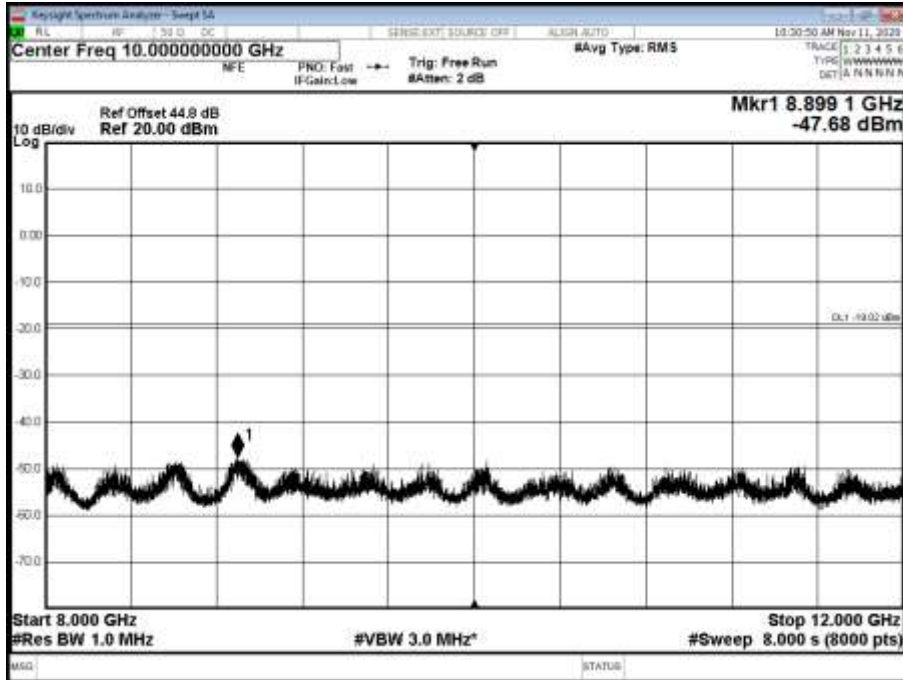

Antenna A - NR Modulation QPSK - NR Carrier Bandwidth 10.0 MHz 15 kHz SCS - Channel Position M - Band 4 - Range 12000 to 18000 MHz

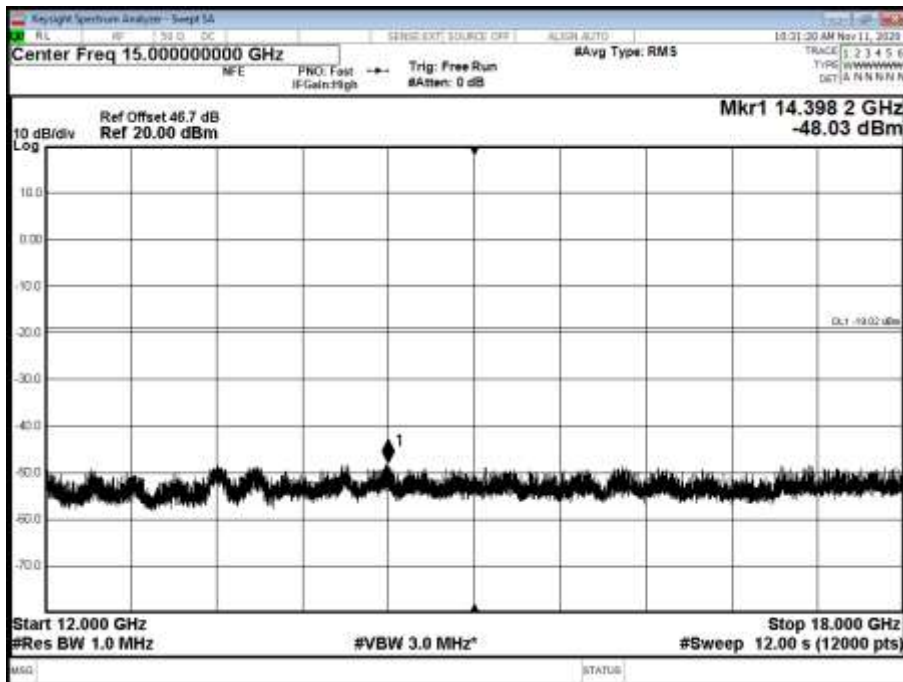



Antenna A - NR Modulation QPSK - NR Carrier Bandwidth 10.0 MHz 15 kHz SCS - Channel Position M - Band 5 - Range 18000 to 21000 MHz

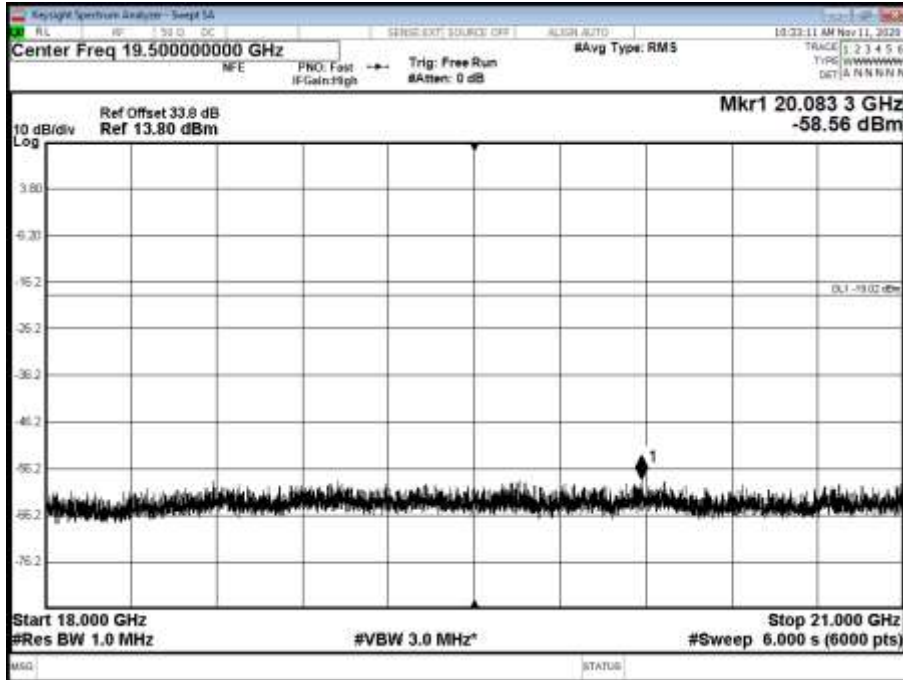

Antenna A - NR Modulation QPSK - NR Carrier Bandwidth 10.0 MHz 15 kHz SCS - Channel Position T - Band 1 - Range 0.009 to 3500 MHz

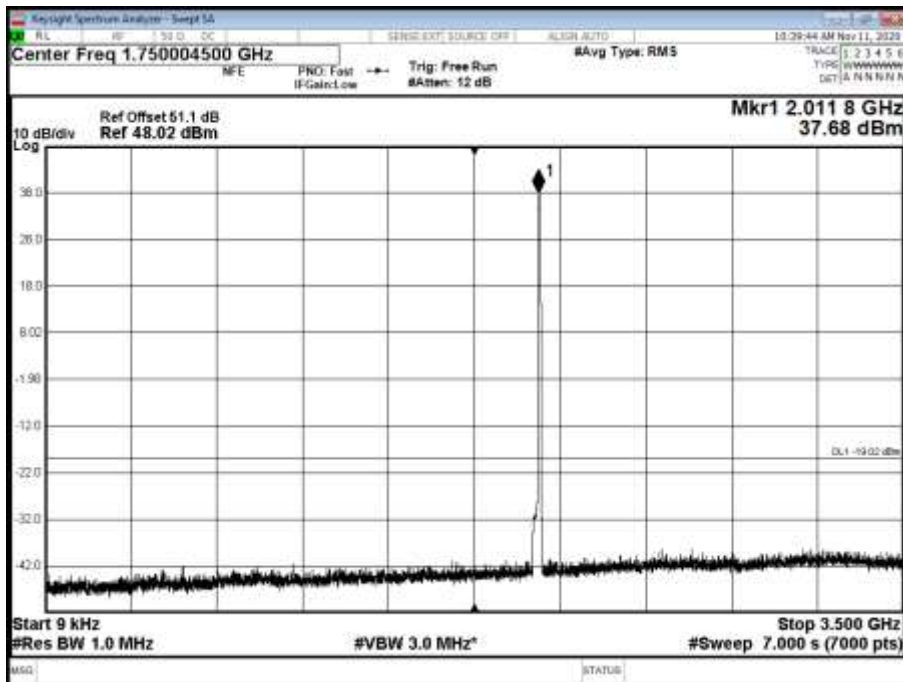



Antenna A - NR Modulation QPSK - NR Carrier Bandwidth 10.0 MHz 15 kHz SCS - Channel Position T - Band 2 - Range 3500 to 8000 MHz

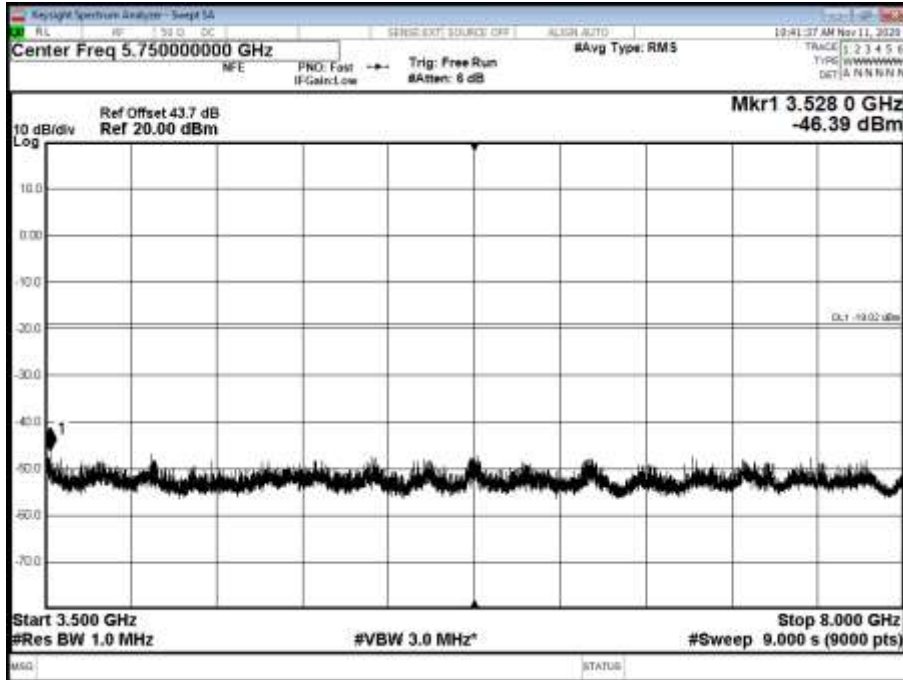

Antenna A - NR Modulation QPSK - NR Carrier Bandwidth 10.0 MHz 15 kHz SCS - Channel Position T - Band 3 - Range 8000 to 12000 MHz

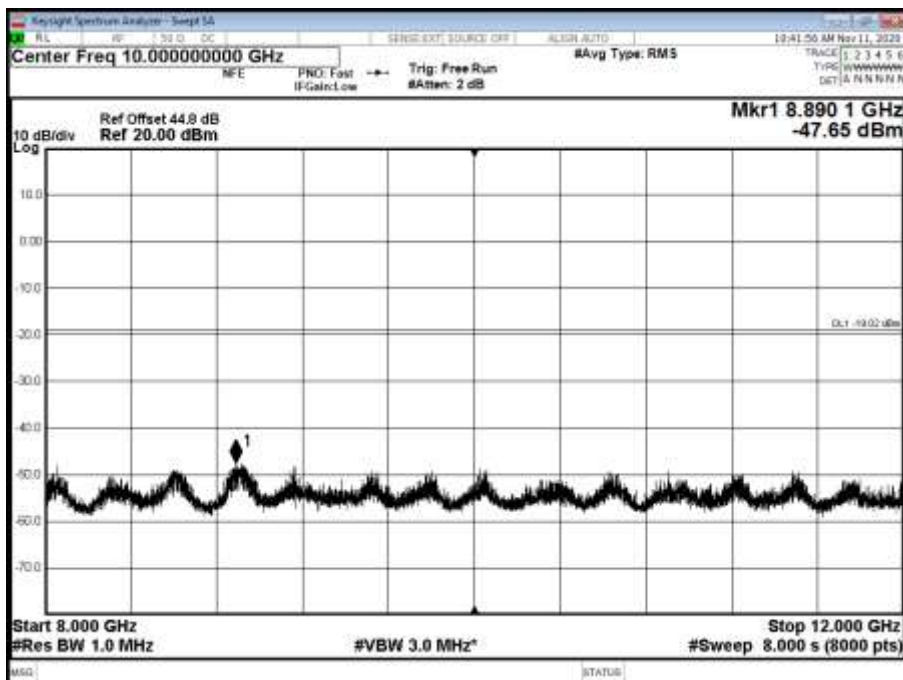





Antenna A - NR Modulation QPSK - NR Carrier Bandwidth 10.0 MHz 15 kHz SCS - Channel Position T - Band 4 - Range 12000 to 18000 MHz

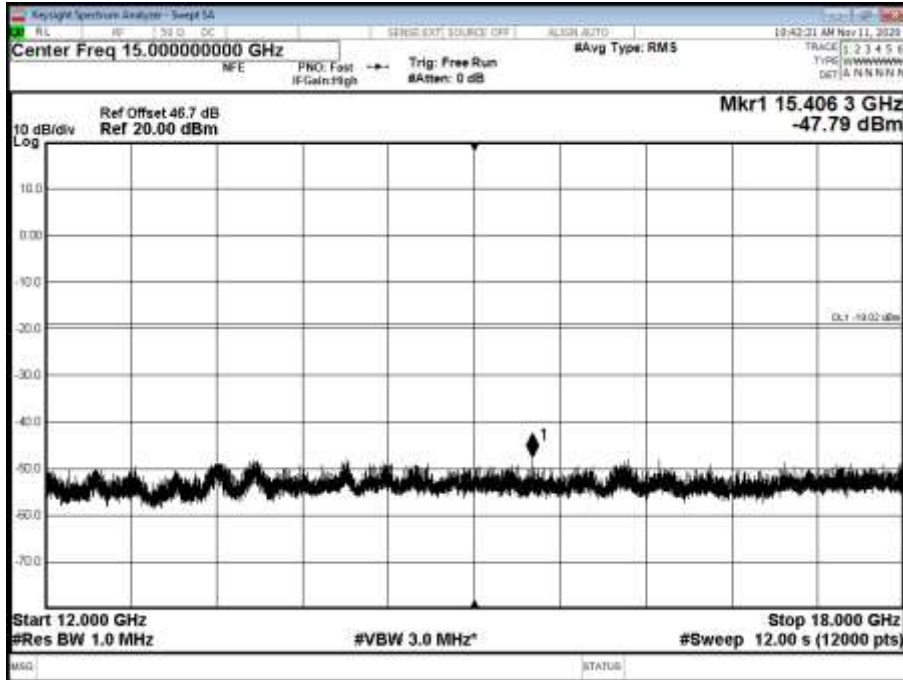

Antenna A - NR Modulation QPSK - NR Carrier Bandwidth 10.0 MHz 15 kHz SCS - Channel Position T - Band 5 - Range 18000 to 21000 MHz

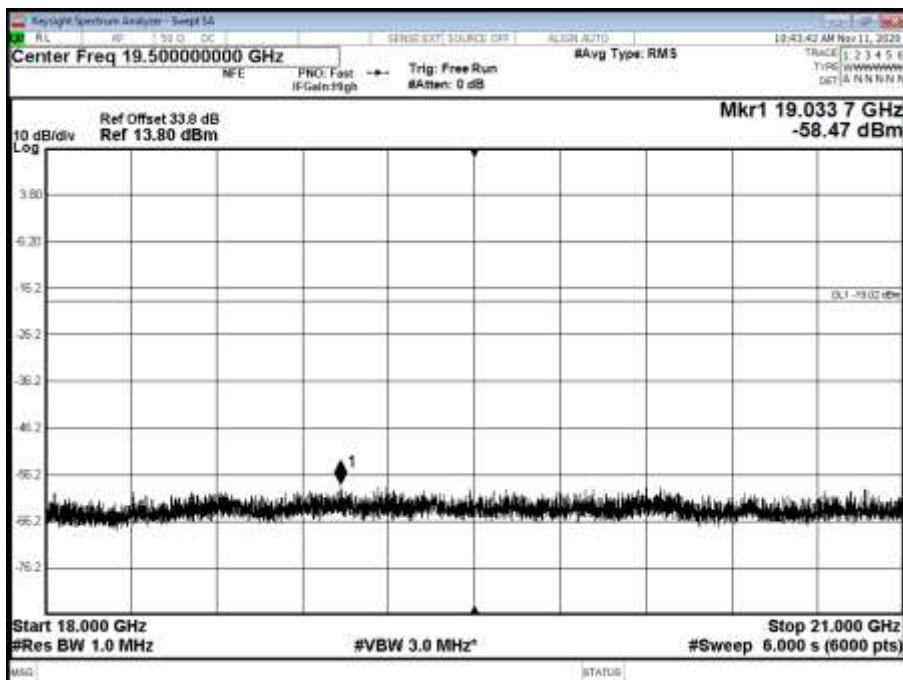



Antenna A - NR Modulation QPSK - NR Carrier Bandwidth 15.0 MHz 15 kHz SCS - Channel Position B - Band 1 - Range 0.009 to 3500 MHz

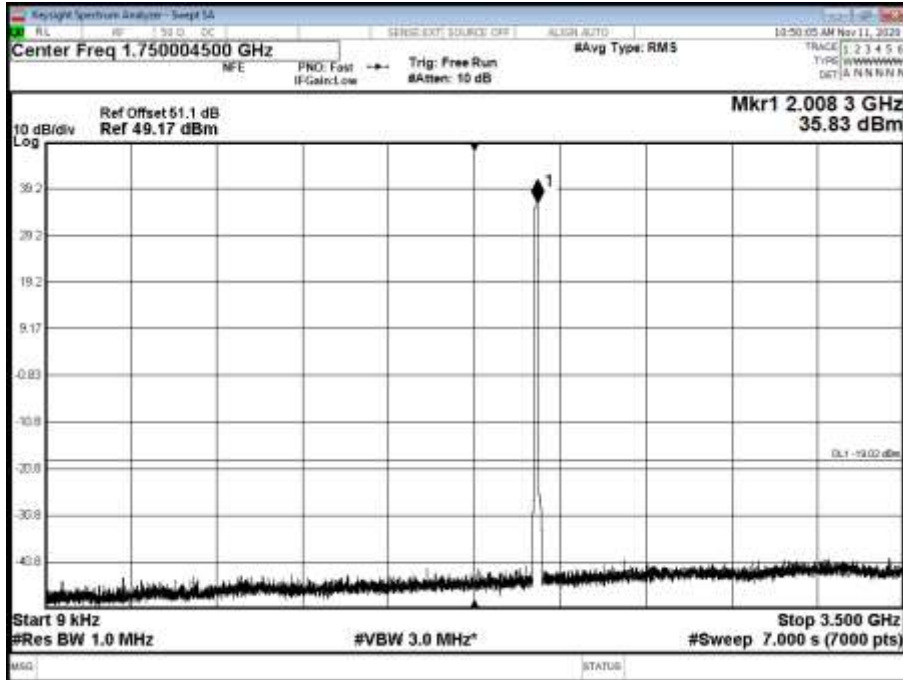

Antenna A - NR Modulation QPSK - NR Carrier Bandwidth 15.0 MHz 15 kHz SCS - Channel Position B - Band 2 - Range 3500 to 8000 MHz

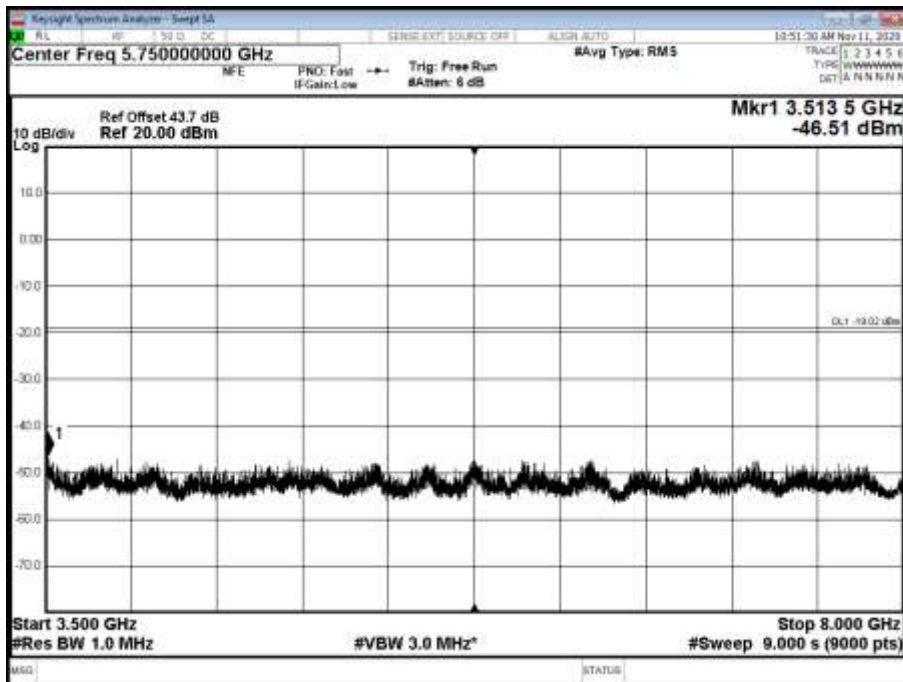



Antenna A - NR Modulation QPSK - NR Carrier Bandwidth 15.0 MHz 15 kHz SCS - Channel Position B - Band 3 - Range 8000 to 12000 MHz

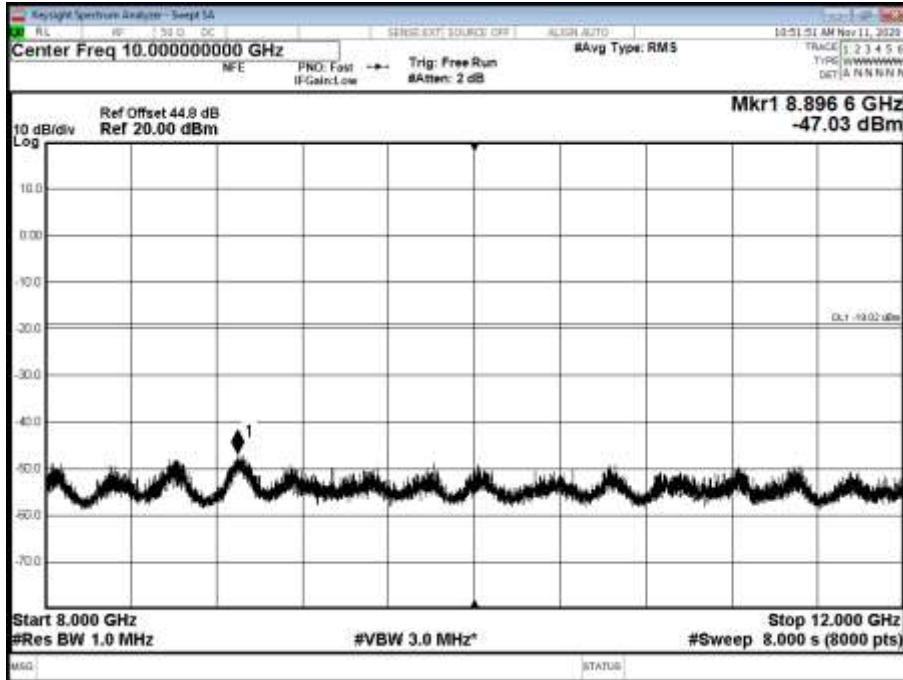

Antenna A - NR Modulation QPSK - NR Carrier Bandwidth 15.0 MHz 15 kHz SCS - Channel Position B - Band 4 - Range 12000 to 18000 MHz

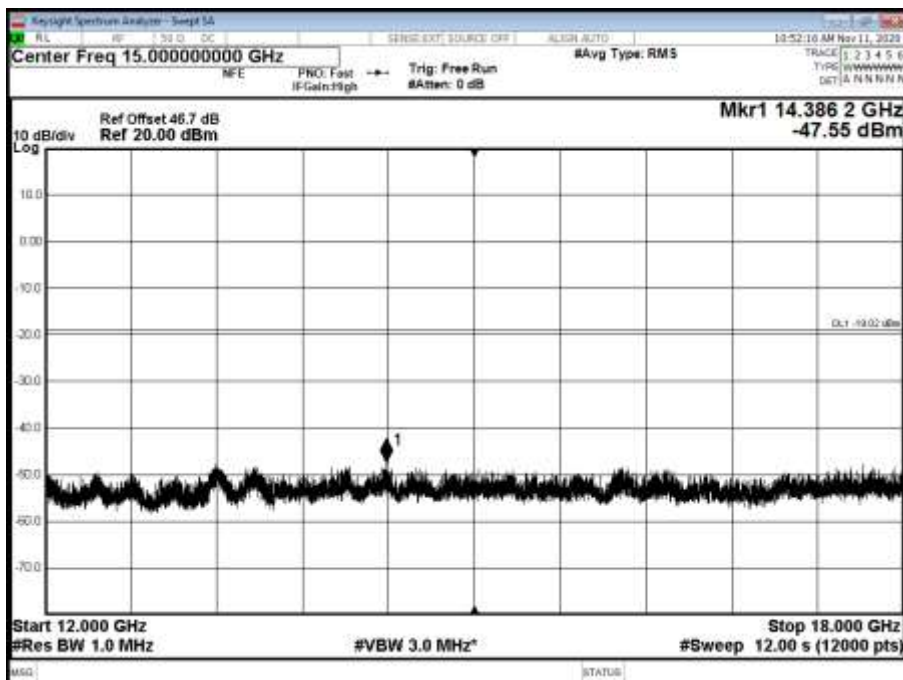



Antenna A - NR Modulation QPSK - NR Carrier Bandwidth 15.0 MHz 15 kHz SCS - Channel Position B - Band 5 - Range 18000 to 21000 MHz

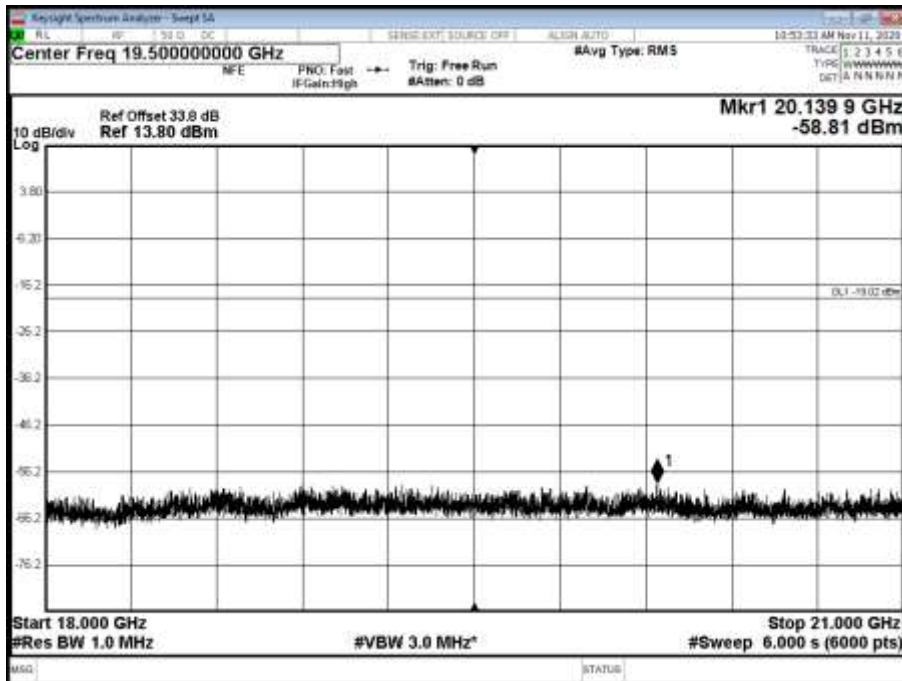

Antenna A - NR Modulation QPSK - NR Carrier Bandwidth 15.0 MHz 15 kHz SCS - Channel Position M - Band 1 - Range 0.009 to 3500 MHz

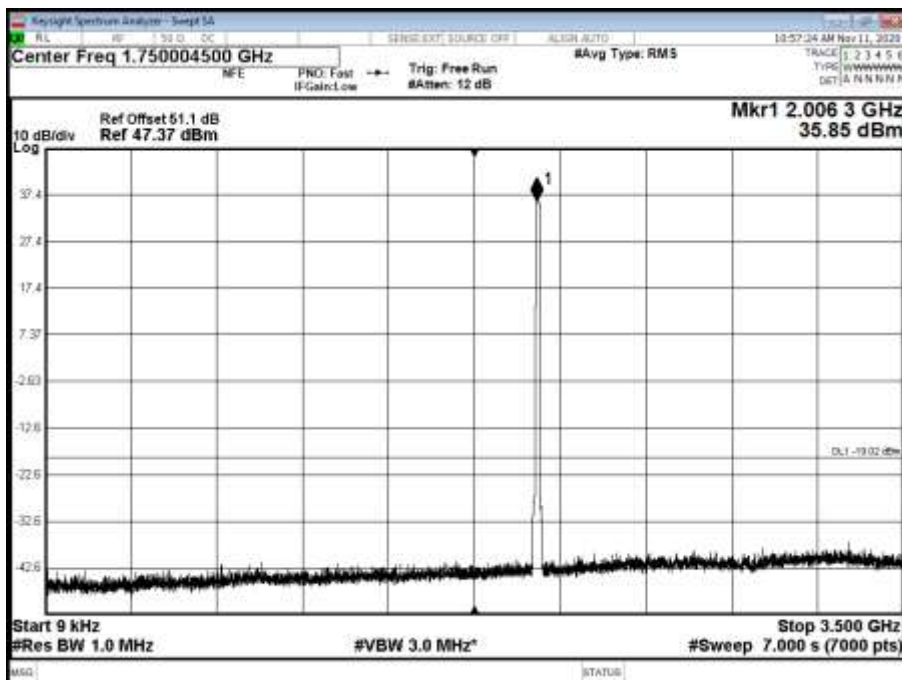



Antenna A - NR Modulation QPSK - NR Carrier Bandwidth 15.0 MHz 15 kHz SCS - Channel Position M - Band 2 - Range 3500 to 8000 MHz

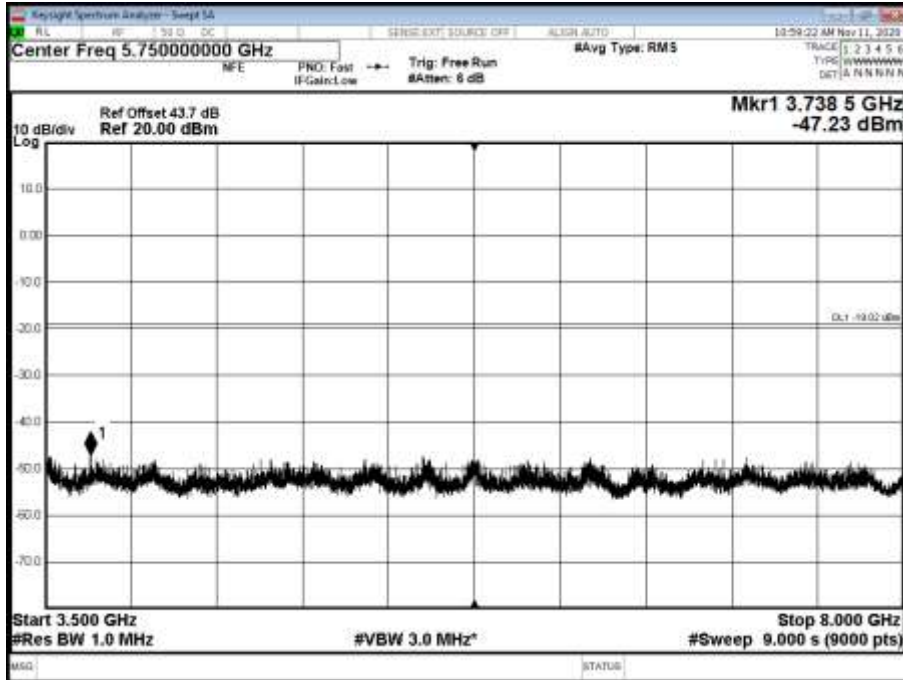

Antenna A - NR Modulation QPSK - NR Carrier Bandwidth 15.0 MHz 15 kHz SCS - Channel Position M - Band 3 - Range 8000 to 12000 MHz

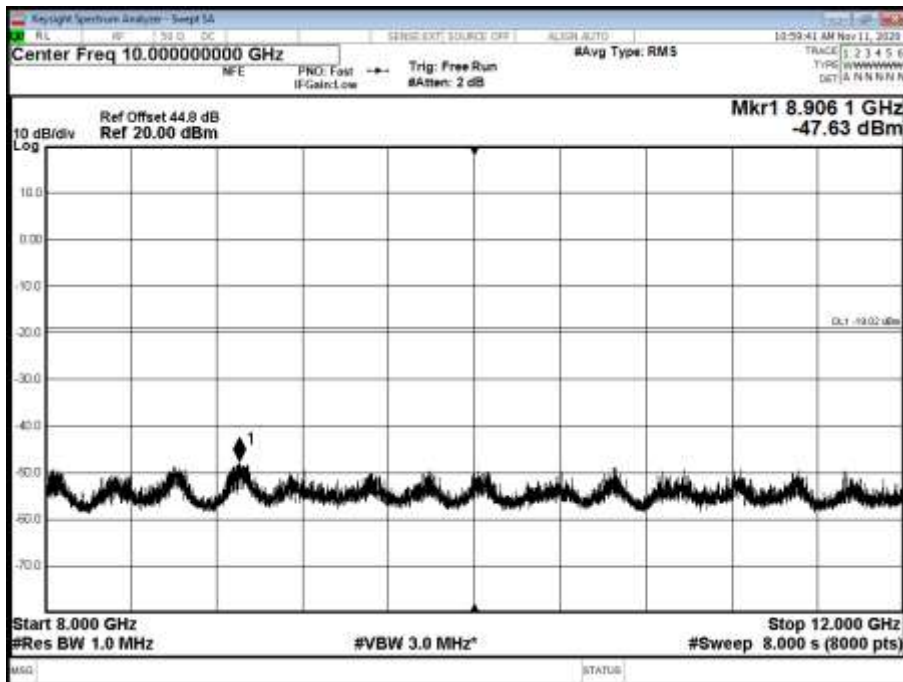



Antenna A - NR Modulation QPSK - NR Carrier Bandwidth 15.0 MHz 15 kHz SCS - Channel Position M - Band 4 - Range 12000 to 18000 MHz

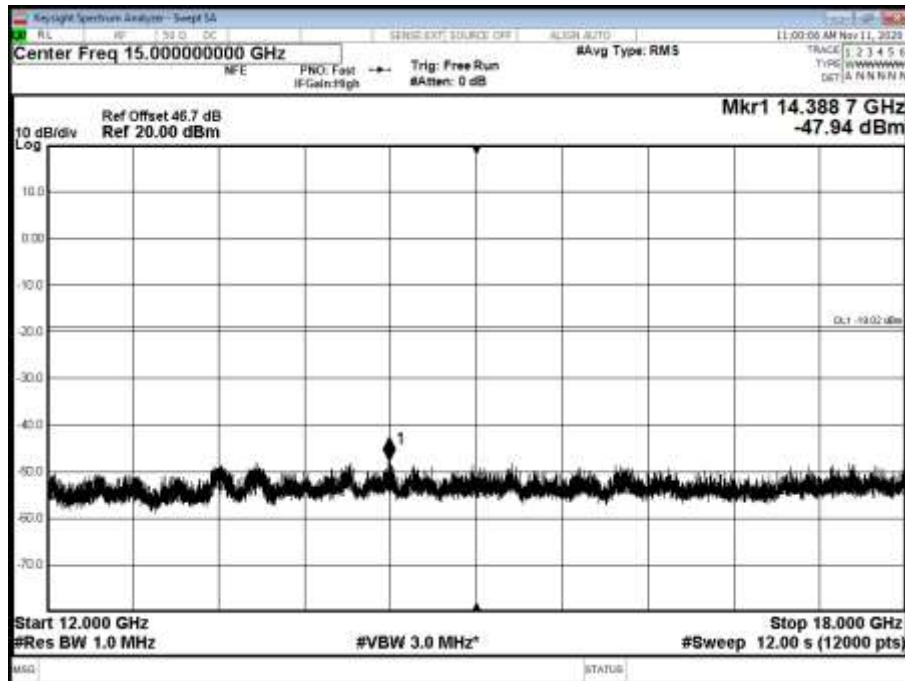

Antenna A - NR Modulation QPSK - NR Carrier Bandwidth 15.0 MHz 15 kHz SCS - Channel Position M - Band 5 - Range 18000 to 21000 MHz

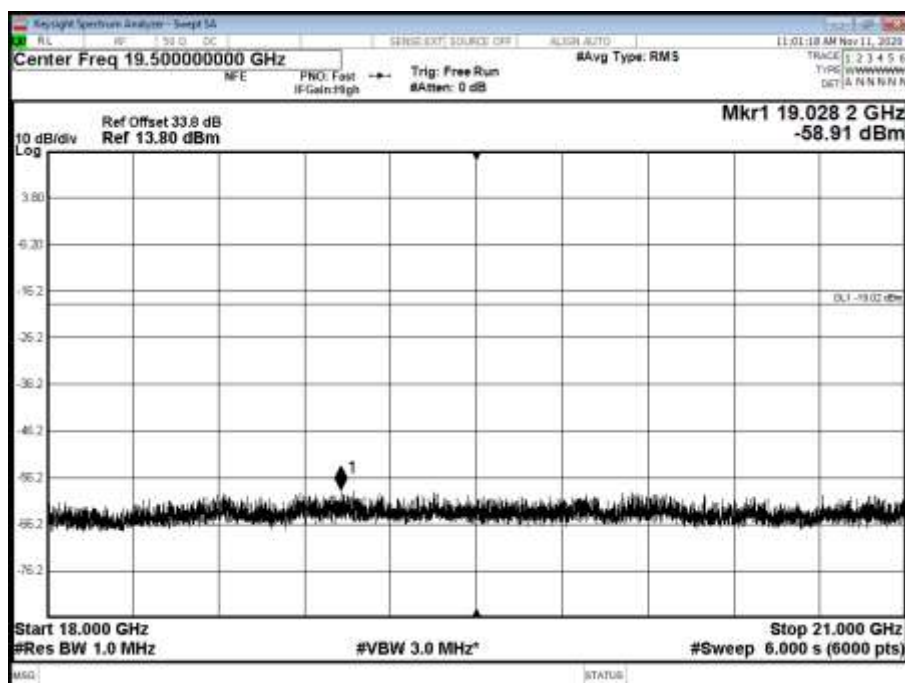



Antenna A - NR Modulation QPSK - NR Carrier Bandwidth 15.0 MHz 15 kHz SCS - Channel Position T - Band 1 - Range 0.009 to 3500 MHz

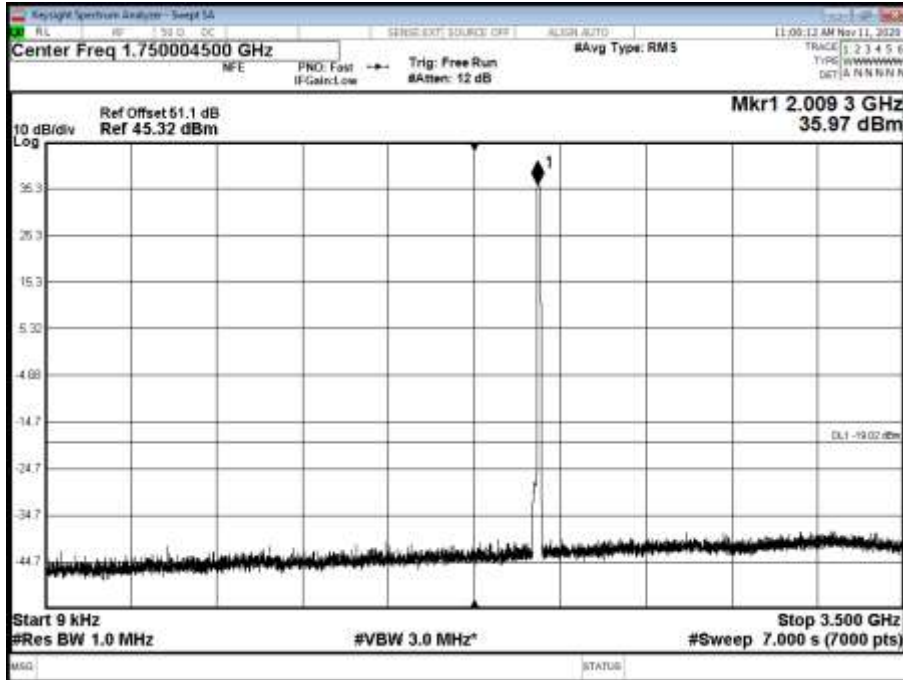

Antenna A - NR Modulation QPSK - NR Carrier Bandwidth 15.0 MHz 15 kHz SCS - Channel Position T - Band 2 - Range 3500 to 8000 MHz

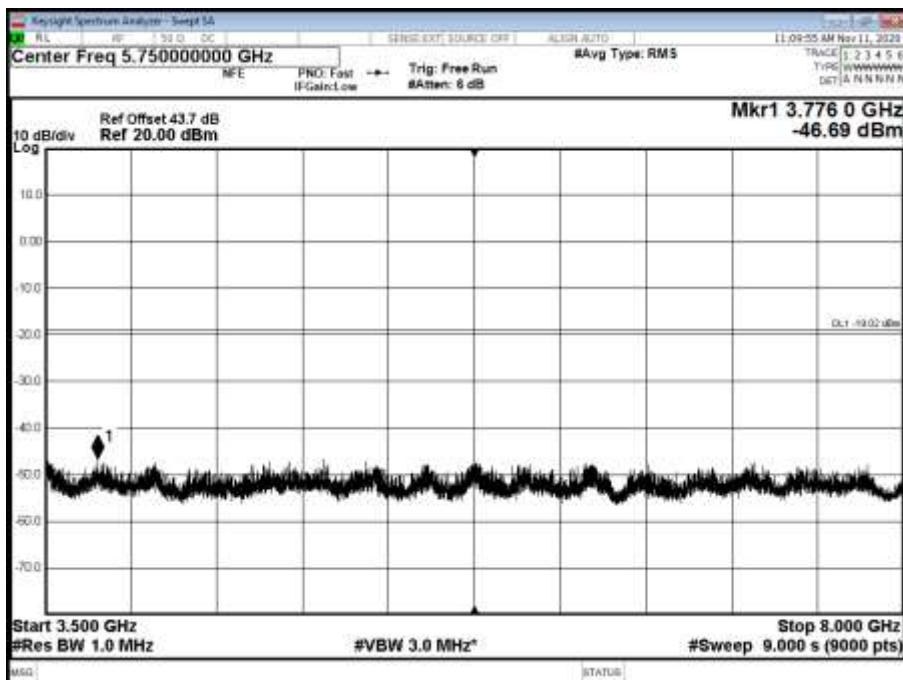



Antenna A - NR Modulation QPSK - NR Carrier Bandwidth 15.0 MHz 15 kHz SCS - Channel Position T - Band 3 - Range 8000 to 12000 MHz

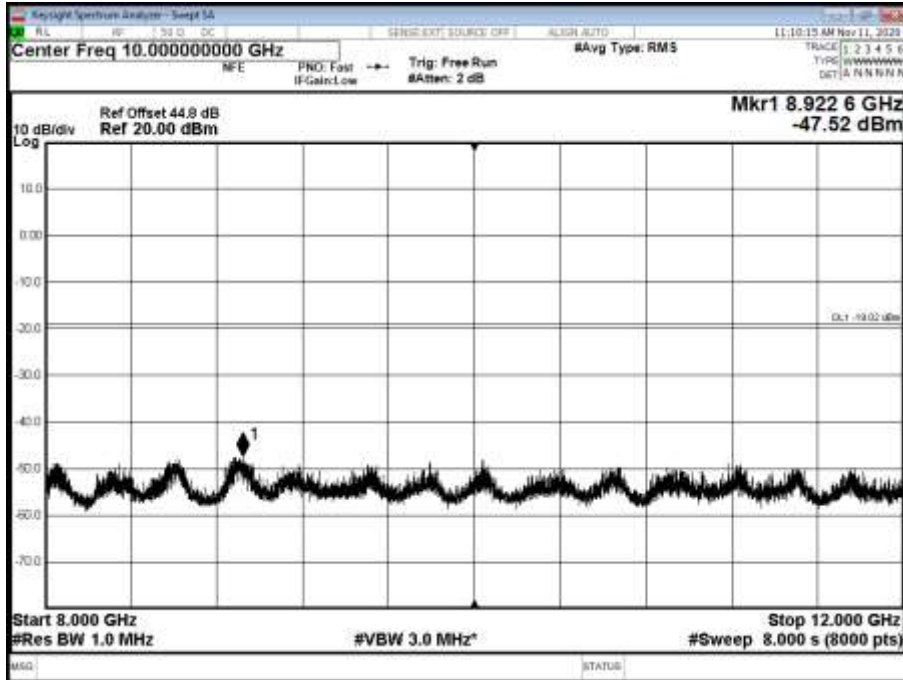

Antenna A - NR Modulation QPSK - NR Carrier Bandwidth 15.0 MHz 15 kHz SCS - Channel Position T - Band 4 - Range 12000 to 18000 MHz

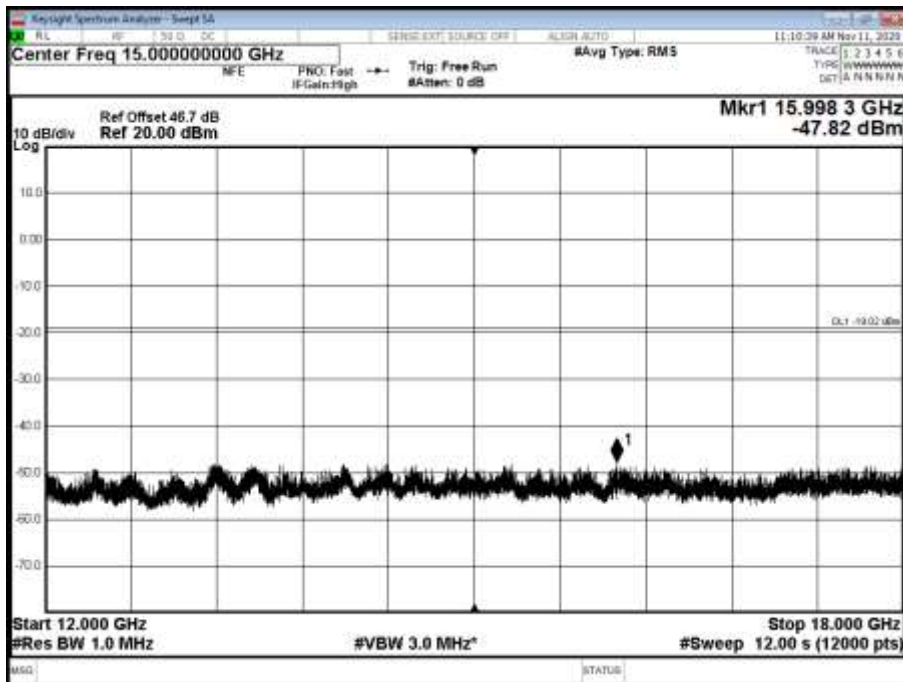





Antenna A - NR Modulation QPSK - NR Carrier Bandwidth 15.0 MHz 15 kHz SCS - Channel Position T - Band 5 - Range 18000 to 21000 MHz

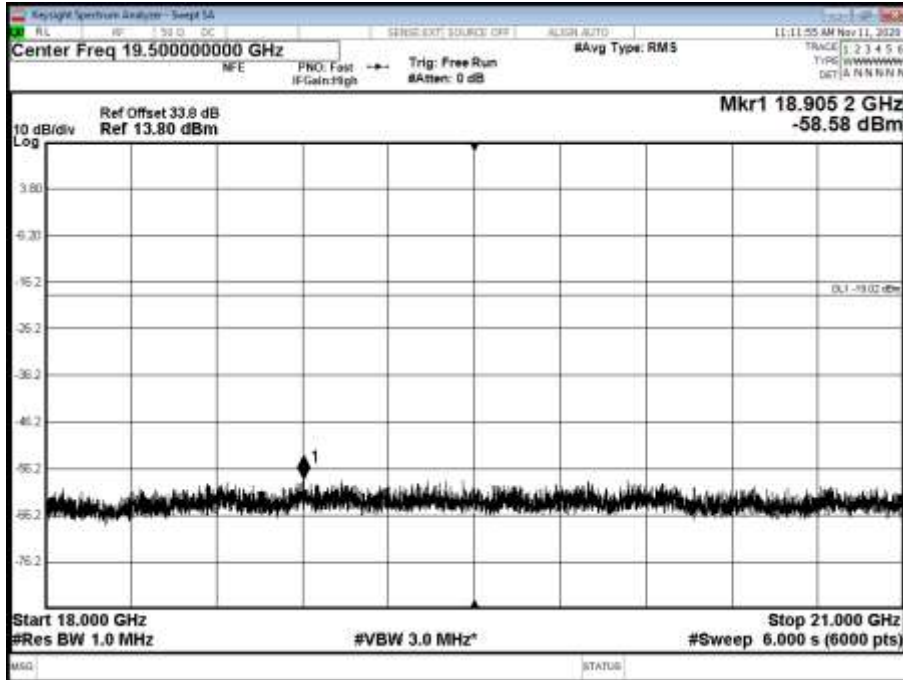

Antenna A - NR Modulation QPSK - NR Carrier Bandwidth 20.0 MHz 15 kHz SCS - Channel Position B - Band 1 - Range 0.009 to 3500 MHz

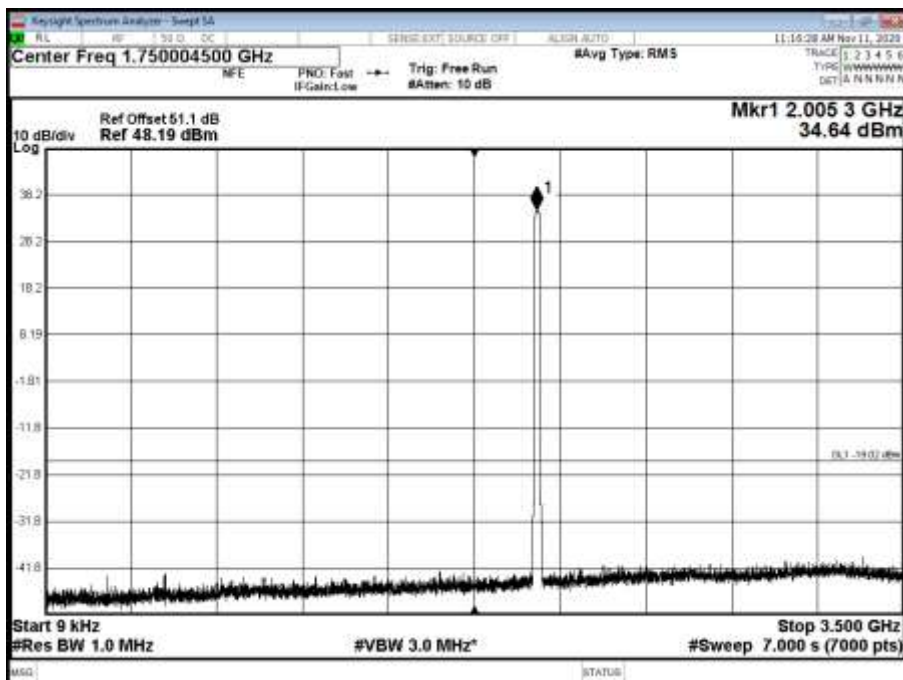



Antenna A - NR Modulation QPSK - NR Carrier Bandwidth 20.0 MHz 15 kHz SCS - Channel Position B - Band 2 - Range 3500 to 8000 MHz

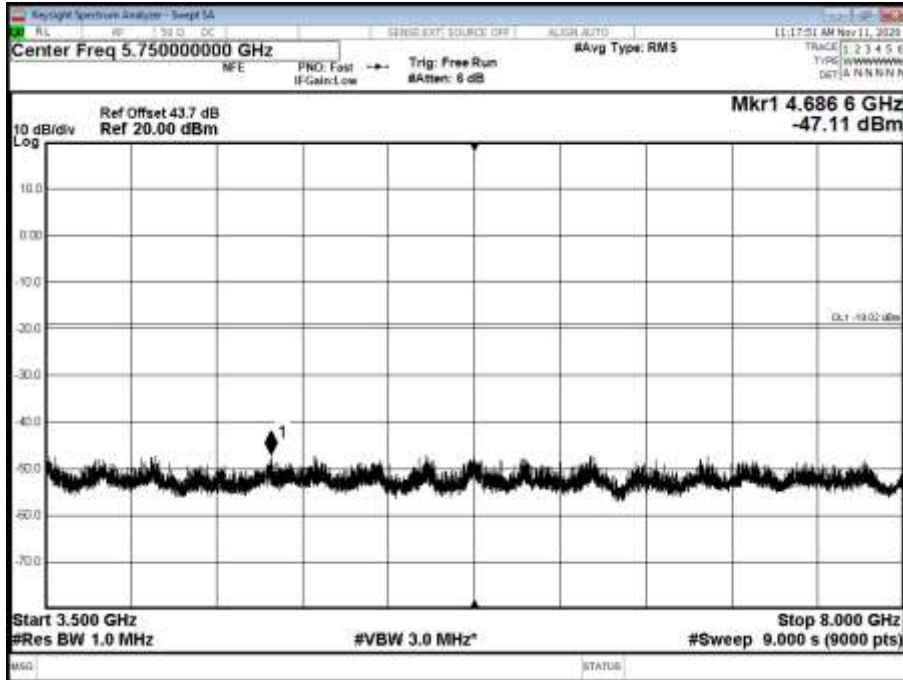

Antenna A - NR Modulation QPSK - NR Carrier Bandwidth 20.0 MHz 15 kHz SCS - Channel Position B - Band 3 - Range 8000 to 12000 MHz

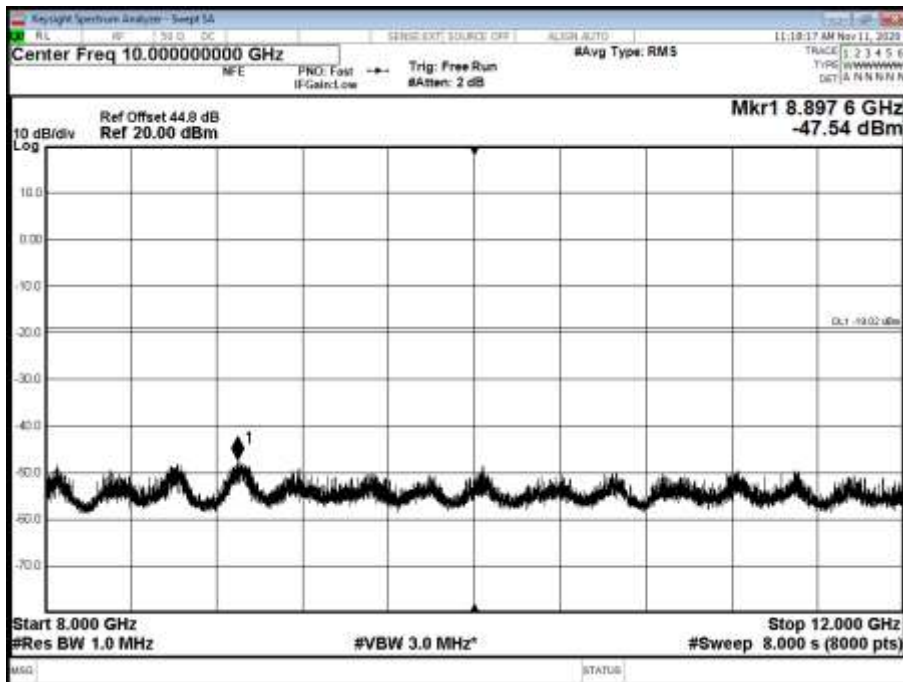



Antenna A - NR Modulation QPSK - NR Carrier Bandwidth 20.0 MHz 15 kHz SCS - Channel Position B - Band 4 - Range 12000 to 18000 MHz

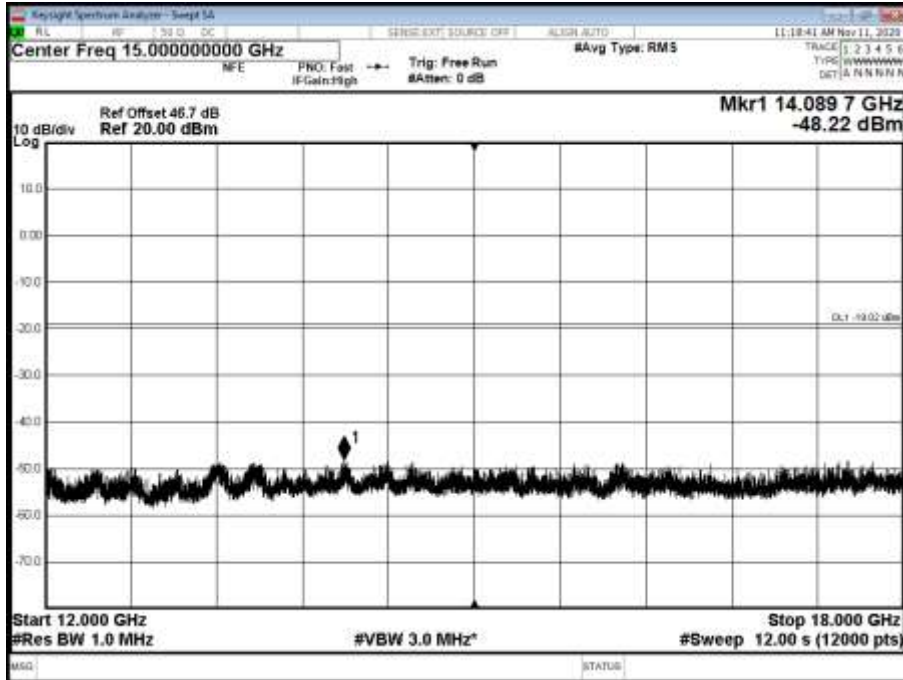

Antenna A - NR Modulation QPSK - NR Carrier Bandwidth 20.0 MHz 15 kHz SCS - Channel Position B - Band 5 - Range 18000 to 21000 MHz

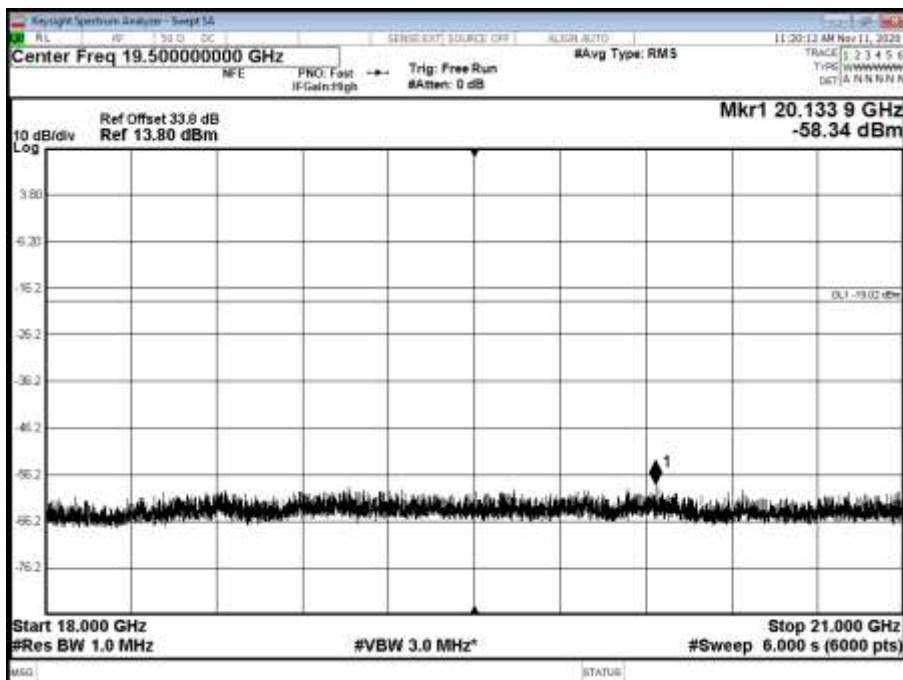



Antenna A - NR Modulation QPSK - NR Carrier Bandwidth 20.0 MHz 15 kHz SCS - Channel Position M - Band 1 - Range 0.009 to 3500 MHz

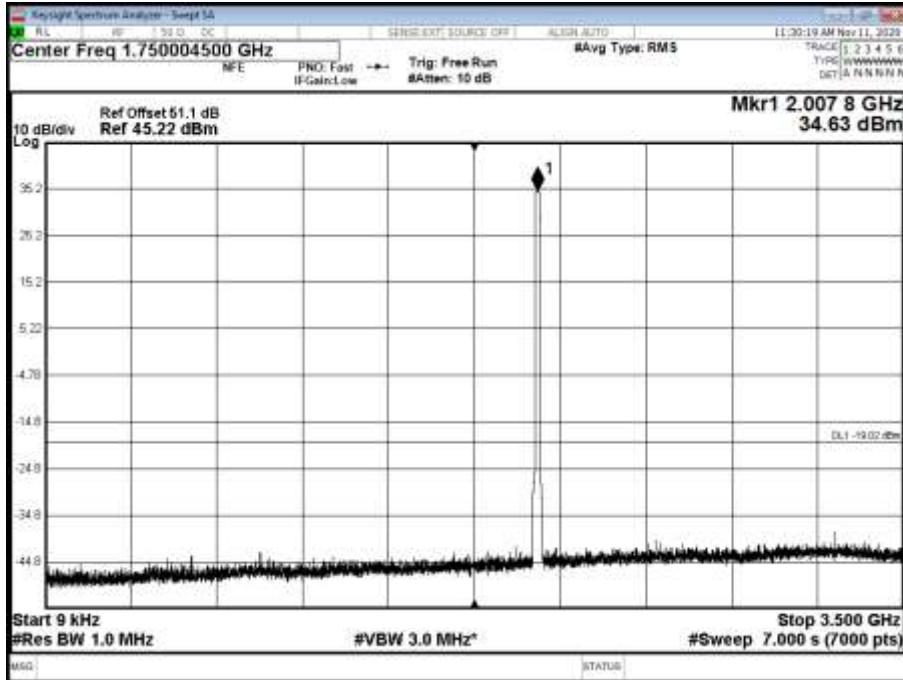

Antenna A - NR Modulation QPSK - NR Carrier Bandwidth 20.0 MHz 15 kHz SCS - Channel Position M - Band 2 - Range 3500 to 8000 MHz

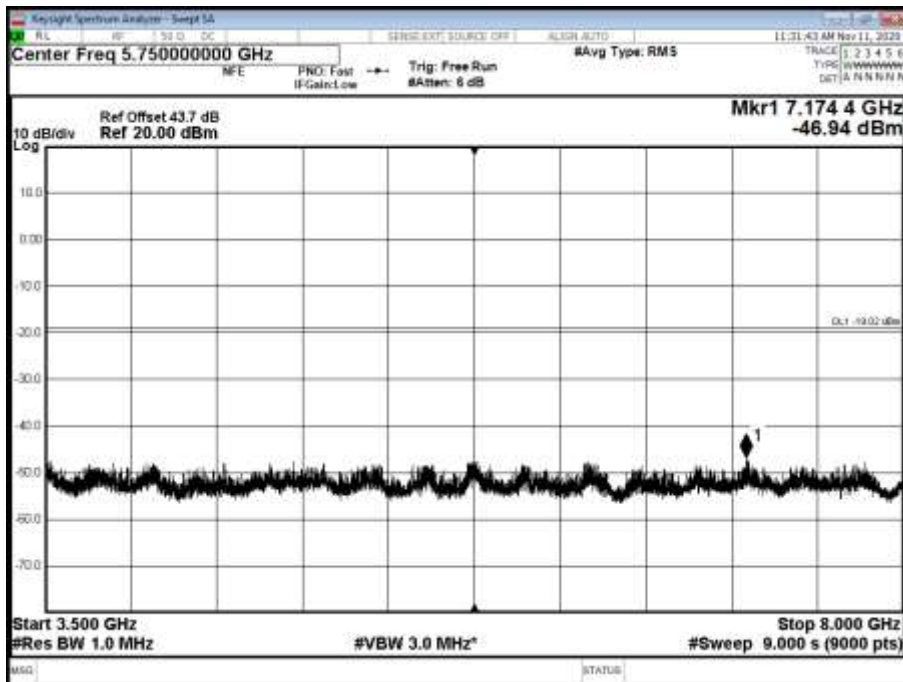



Antenna A - NR Modulation QPSK - NR Carrier Bandwidth 20.0 MHz 15 kHz SCS - Channel Position M - Band 3 - Range 8000 to 12000 MHz

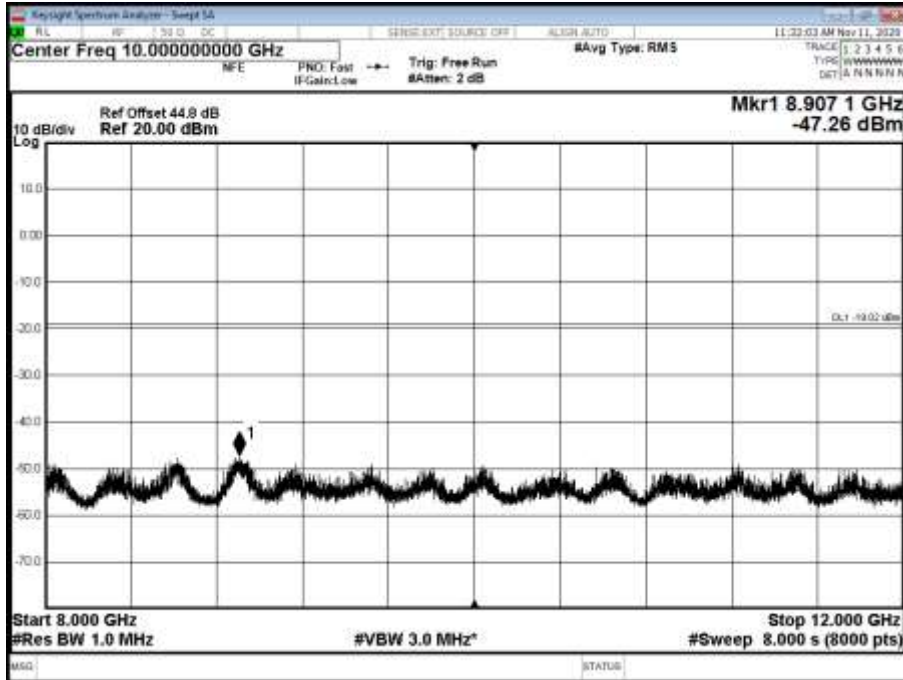

Antenna A - NR Modulation QPSK - NR Carrier Bandwidth 20.0 MHz 15 kHz SCS - Channel Position M - Band 4 - Range 12000 to 18000 MHz

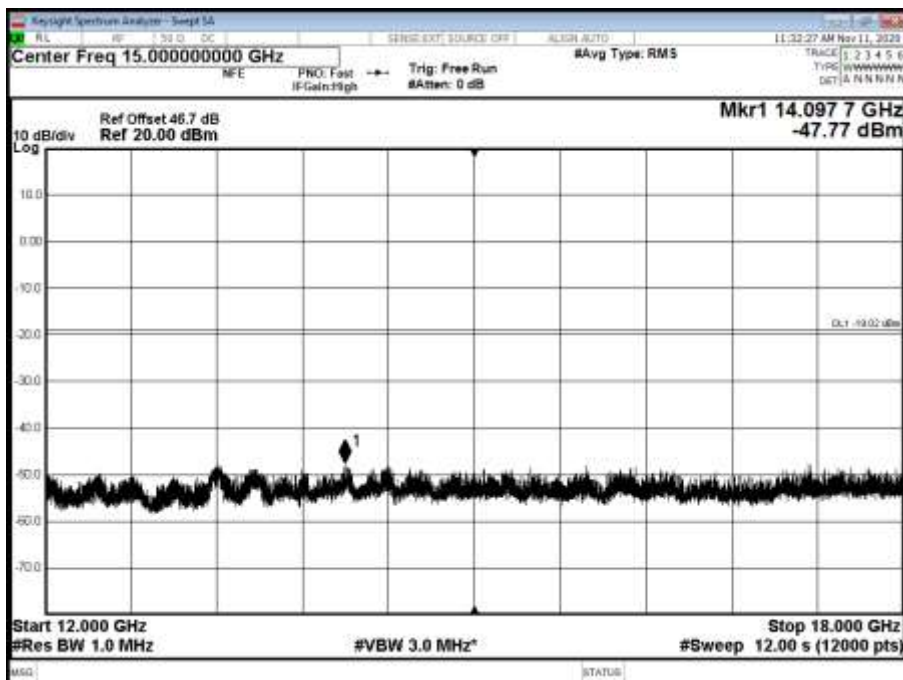



Antenna A - NR Modulation QPSK - NR Carrier Bandwidth 20.0 MHz 15 kHz SCS - Channel Position M - Band 5 - Range 18000 to 21000 MHz

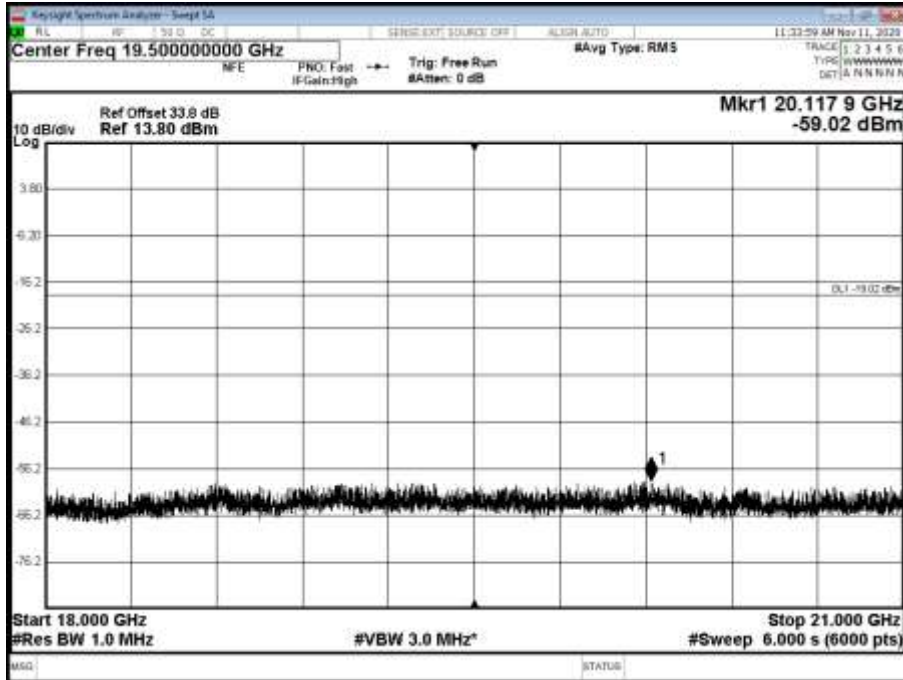

Antenna A - NR Modulation QPSK - NR Carrier Bandwidth 20.0 MHz 15 kHz SCS - Channel Position T - Band 1 - Range 0.009 to 3500 MHz

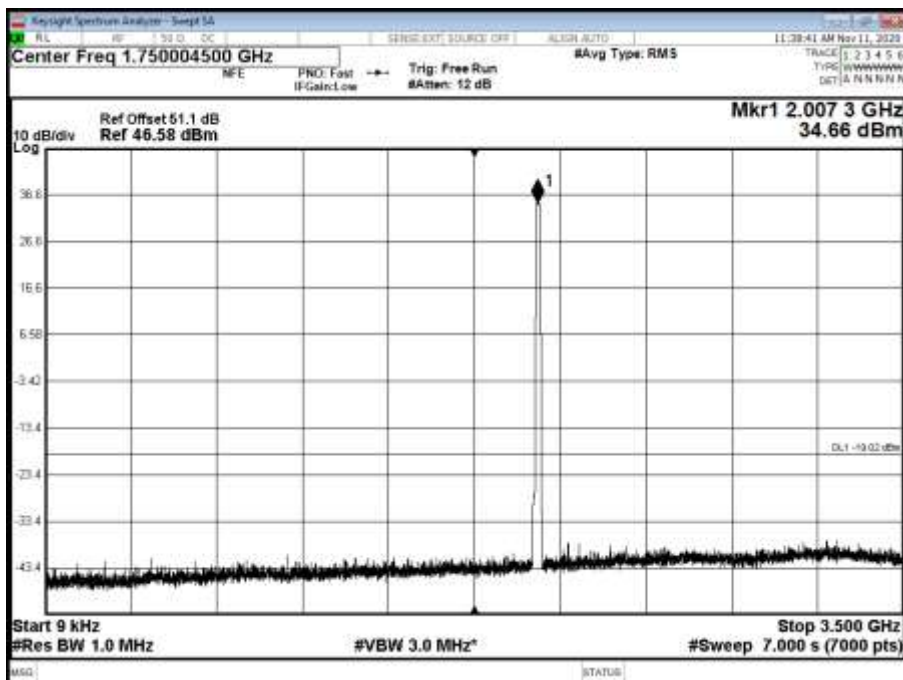



Antenna A - NR Modulation QPSK - NR Carrier Bandwidth 20.0 MHz 15 kHz SCS - Channel Position T - Band 2 - Range 3500 to 8000 MHz

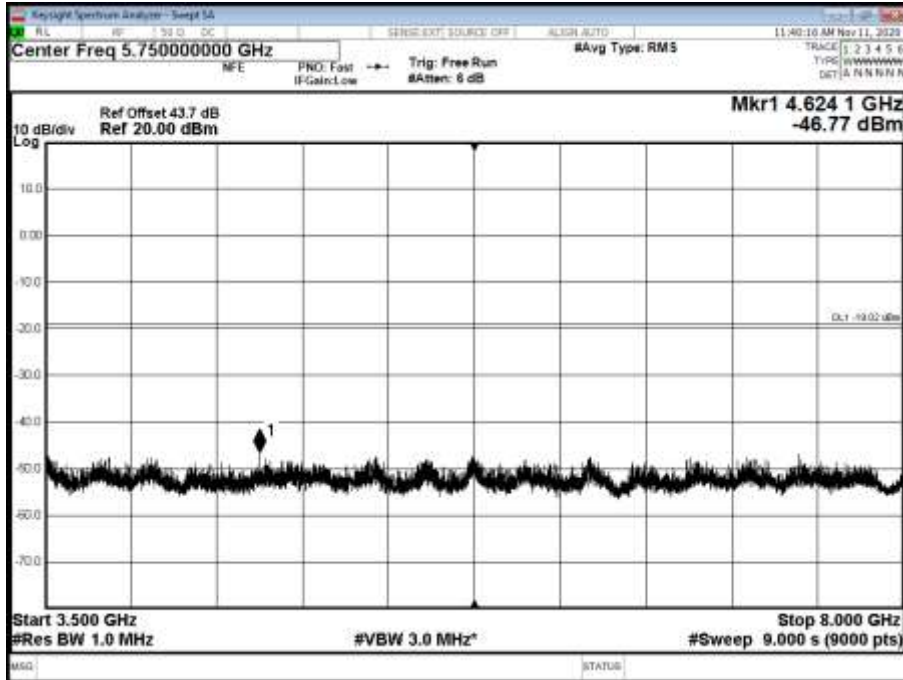

Antenna A - NR Modulation QPSK - NR Carrier Bandwidth 20.0 MHz 15 kHz SCS - Channel Position T - Band 3 - Range 8000 to 12000 MHz

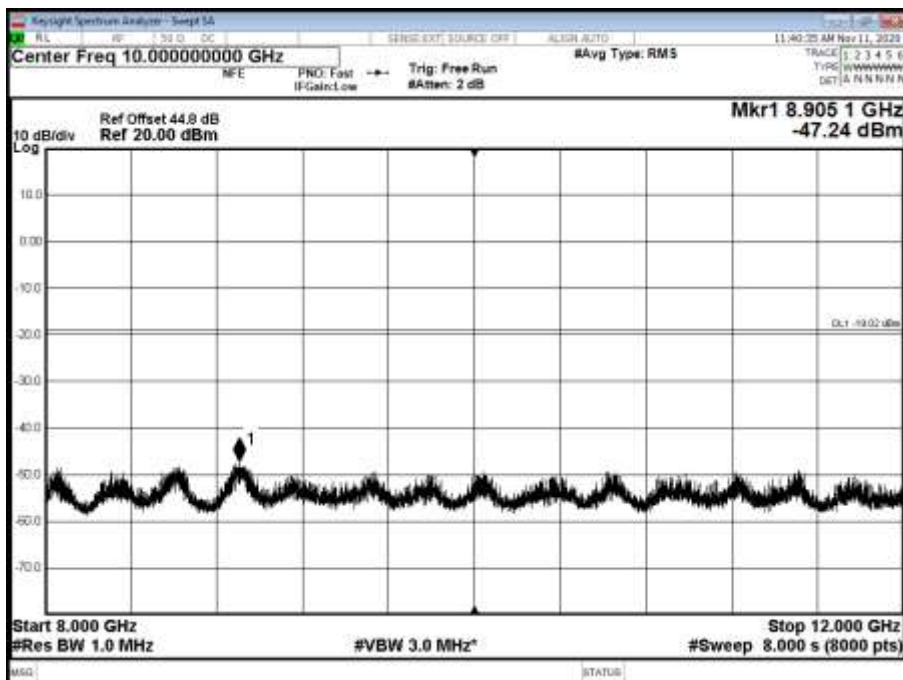



Antenna A - NR Modulation QPSK - NR Carrier Bandwidth 20.0 MHz 15 kHz SCS - Channel Position T - Band 4 - Range 12000 to 18000 MHz

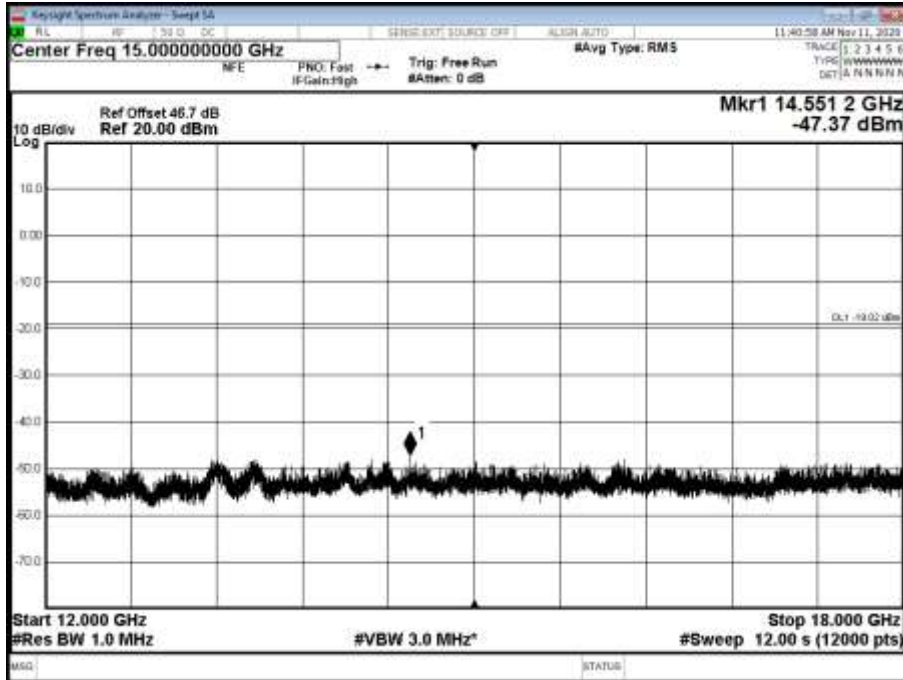

Antenna A - NR Modulation QPSK - NR Carrier Bandwidth 20.0 MHz 15 kHz SCS - Channel Position T - Band 5 - Range 18000 to 21000 MHz

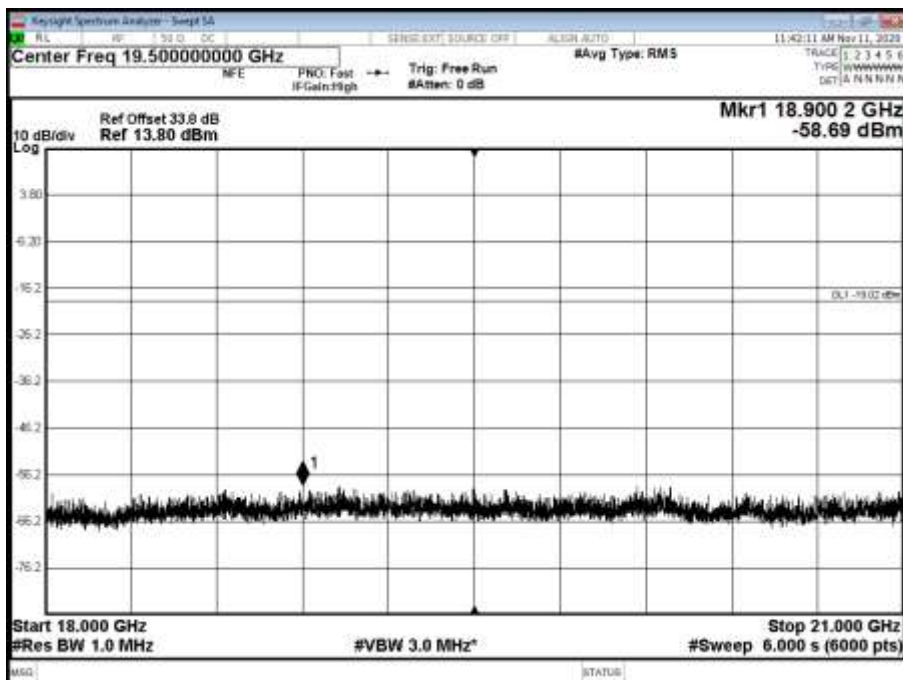

Limit	-19dBm
-------	--------





### **SECTION 3**

#### **TEST EQUIPMENT USED**



### 3.1 TEST EQUIPMENT USED

List of absolute measuring and other principal items of test equipment.

Instrument	Manufacturer	Type No.	TE No.	Calibration Period (months)	Calibration Due
<b>Maximum Peak Output Power and Peak to Average Ratio - Conducted</b>					
Thermo-Hygro-Barometer	PCE Instruments	PCE-THB-40	5480	12	18-Mar-2021
Power Supply	Rohde & Schwarz	HMP4040	4954	-	O/P MON
Multimeter	Fluke	79	3057	12	21-Aug-2021
Attenuator 10dB 100W	Weinschel	48-10-43	4867	12	23-Jul-2021
Attenuator 40dB 100W	Weinschel	48-40-43-LIM	5134	12	29-Nov-2020
PXA Signal Analyser	Keysight	N9030A	4653	12	10-Feb-2021
Frequency Standard	Spectracom	SecureSync 1200-0408-0601	4393	6	08-May-2021
Rubidium Standard	Rohde & Schwarz	XSRM	1316	6	08-May-2021
Analyser	Rohde & Schwarz	ZVA 40	3548	12	11-Dec-2020
Calibration Kit	Rohde & Schwarz	ZV-Z54	4368	12	28-Nov-2020
<b>Occupied Bandwidth</b>					
Thermo-Hygro-Barometer	PCE Instruments	PCE-THB-40	5480	12	18-Mar-2021
Power Supply	Rohde & Schwarz	HMP4040	4954	-	O/P MON
Multimeter	Fluke	79	3057	12	21-Aug-2021
Attenuator 10dB 100W	Weinschel	48-10-43	4867	12	23-Jul-2021
Attenuator 40dB 100W	Weinschel	48-40-43-LIM	5134	12	29-Nov-2020
PXA Signal Analyser	Keysight	N9030A	4653	12	10-Feb-2021
Frequency Standard	Spectracom	SecureSync 1200-0408-0601	4393	6	08-May-2021
Rubidium Standard	Rohde & Schwarz	XSRM	1316	6	08-May-2021
Analyser	Rohde & Schwarz	ZVA 40	3548	12	11-Dec-2020
Calibration Kit	Rohde & Schwarz	ZV-Z54	4368	12	28-Nov-2020
<b>Band Edge</b>					
Thermo-Hygro-Barometer	PCE Instruments	PCE-THB-40	5480	12	18-Mar-2021
Power Supply	Rohde & Schwarz	HMP4040	4954	-	O/P MON
Multimeter	Fluke	79	3057	12	21-Aug-2021
Attenuator 10dB 100W	Weinschel	48-10-43	4867	12	23-Jul-2021
Attenuator 40dB 100W	Weinschel	48-40-43-LIM	5134	12	29-Nov-2020
PXA Signal Analyser	Keysight	N9030A	4653	12	10-Feb-2021
Frequency Standard	Spectracom	SecureSync 1200-0408-0601	4393	6	08-May-2021
Rubidium Standard	Rohde & Schwarz	XSRM	1316	6	08-May-2021
Analyser	Rohde & Schwarz	ZVA 40	3548	12	11-Dec-2020
Calibration Kit	Rohde & Schwarz	ZV-Z54	4368	12	28-Nov-2020
<b>Transmitter Spurious Emissions</b>					
Thermo-Hygro-Barometer	PCE Instruments	PCE-THB-40	5480	12	18-Mar-2021
Power Supply	Rohde & Schwarz	HMP4040	4954	-	O/P MON
Multimeter	Fluke	79	3057	12	21-Aug-2021



Instrument	Manufacturer	Type No.	TE No.	Calibration Period (months)	Calibration Due
Attenuator 10dB 100W	Weinschel	48-10-43	4867	12	23-Jul-2021
Attenuator 40dB 100W	Weinschel	48-40-43-LIM	5134	12	29-Nov-2020
PXA Signal Analyser	Keysight	N9030A	4653	12	10-Feb-2021
Frequency Standard	Spectracom	SecureSync 1200-0408-0601	4393	6	08-May-2021
Rubidium Standard	Rohde & Schwarz	XSRM	1316	6	08-May-2021
Analyser	Rohde & Schwarz	ZVA 40	3548	12	11-Dec-2020
Calibration Kit	Rohde & Schwarz	ZV-Z54	4368	12	28-Nov-2020
Cable attenuator	Aralab	CSF6767C-C2S6500	5175	-	O/P MON
HPF 3GHz	Advance Power Components	11SH10-3000/X18000-O/O	4411	12	01-Jul-2021
Waveguide	FMI UK	18-26 GHz	-	-	O/P MON

N/A – Not Applicable

O/P Mon – Output Monitored with Calibrated Equipment



### 3.2 MEASUREMENT UNCERTAINTY

For a 95% confidence level, the measurement uncertainties for defined systems are:-

Test Discipline	Frequency / Parameter	MU	
Conducted Maximum Peak Output Power	30 MHz to 20 GHz Amplitude	$\pm 0.885$ dB	
Conducted Emissions	30 MHz to 20 GHz Amplitude	$\pm 1.782$ dB	
Occupied Bandwidth	Up to 20 MHz Bandwidth	5 MHz Bandwidth	$\pm 33321$ Hz
		10 MHz Bandwidth	$\pm 67172$ Hz
		15 MHz Bandwidth	$\pm 346046$ Hz
		20 MHz Bandwidth	$\pm 91060$ Hz
Band Edge	30 MHz to 20 GHz Amplitude	$\pm 0.885$ dB	

#### Measurement Uncertainty Decision Rule

Determination of conformity with the specification limits is based on the decision rule according to IEC Guide 115: 2007, clause 4.4.3 and 4.5.1.



## **SECTION 5**

### **ACCREDITATION, DISCLAIMERS AND COPYRIGHT**



#### 4.1 ACCREDITATION, DISCLAIMERS AND COPYRIGHT



This report relates only to the actual item/items tested.

Our UKAS Accreditation does not cover opinions and interpretations and any expressed are outside the scope of our UKAS Accreditation.

Results of tests not covered by our UKAS Accreditation Schedule are marked NUA (Not UKAS Accredited).

© 2021 TÜV SÜD



## **ANNEX A**

### **MODULE LIST**



Configuration A1			
Product	Product No	R-State	Serial No
Radio 4415 B70	KRC161 760/3	R5B	D827942869
Software Version:	CXP9013268/15	Revision:	R84FN