



Report On

FCC Testing of the
Remote Radio Unit Dot 4455/4465 B77DB77GB41 KRY 901 551/1
KRY 901 551/2 LTE, NR, LTE and NR (2496-2690 MHz) Base Station
in accordance with FCC CFR 47 Part 2, FCC CFR 47 Part 27

COMMERCIAL-IN-CONFIDENCE

FCC: TA8AKRY901551-1 & TA8AKRY901551-2

PREPARED BY

Handwritten signature of Glen Westwell in black ink.

Glen Westwell
Senior Test Engineer

APPROVED BY

Handwritten signature of Scott Drysdale in black ink.

Scott Drysdale
Authorised Signatory

DATED

08/25/2023

Document 75959061 B41 Report 01 Issue 2

24-August-2023



CONTENTS

Section	Page No
1	REPORT INFORMATION 2
1.1	Report Details 3
1.2	Brief Summary of Results 4
1.3	Test Rationale..... 5
1.4	Configuration Description 6
1.5	Declaration of Build Status 8
1.6	Product Information 10
1.7	Test Setup 11
1.8	Test Conditions..... 13
1.9	Deviation From The Standard 13
1.10	Modification Record 13
1.11	Additional Information 13
2	TEST DETAILS 14
2.1	Maximum Peak Output Power and Peak to Average Ratio - Conducted..... 15
2.2	Band Edge 53
2.3	Transmitter Spurious Emissions 84
2.4	Frequency Stability 100
3	TEST EQUIPMENT USED 101
3.1	Test Equipment Used 102
3.2	Measurement Uncertainty 103
4	ACCREDITATION, DISCLAIMERS AND COPYRIGHT 104
4.1	Accreditation, Disclaimers and Copyright..... 105
ANNEX A	Module Lists.....A.2



SECTION 1

REPORT INFORMATION



1.1 REPORT DETAILS

Manufacturer	Ericsson
Address	Torshamnsgatan 23 Kista SE-16480 Stockholm Sweden
Product Name & Product Number	Dot 4465 B77DB77GB41 KRY 901 551/2
Serial Number(s)	E96A102435
Software Version	CXP 203 0045/26 - R17B569
Hardware Version	R1A
Non-Tested Variant (See Section 1.11 Additional Information)	Dot 4455 B77DB77GB41 KRY 901 551/1
Test Specification/Issue/Date	FCC CFR 47 Part 2: 2021 FCC CFR 47 Part 27: 2022
Test Plan	RA FCC Test Plan for Dot 4455_4465 B77DB77GB41
Start of Test	3-August r-2023
Finish of Test	9-August-2023
Name of Engineer(s)	Glen Westwell
Related Document(s)	KDB 971168 D01 v02r02 KDB 662911 D01 v02r01 ANSI C63.26-2015

ENGINEERING STATEMENT

The measurements shown in this report were made in accordance with the procedures described on test pages. All reported testing was carried out on a sample equipment to demonstrate compliance with and FCC CFR 47 Part 2: 2021, FCC CFR 47 Part 27: 2022. The sample tested was found to comply with the requirements defined in the applied rules.

Test Engineer(s);

Glen Westwell



1.2 BRIEF SUMMARY OF RESULTS

The tests that have been selected are detailed in the customer Test Plan as defined in section 1.1 of this report. The Test Plan is based on the TÜV SÜD FCC Test Plan Rationale, available on request.

A brief summary of results for each configuration, in accordance with FCC CFR 47 Part 2, FCC CFR 47 Part 27 is shown below.

Section	Specification Clause		Test Description	Result
	FCC CFR 47 Part 2	FCC CFR 47 Part 27		
2.1	2.1046	27.50	Maximum Peak Output Power and Peak to Average Ratio - Conducted	Pass
2.2	2.1051	27.53	Band Edge	Pass
2.3	2.1051	27.53	Transmitter Spurious Emissions	Pass
2.4	2.1055	27.54	Frequency Stability	Pass

Testing in this Report covers only B41 (2496-2690 MHz)



1.3 TEST RATIONALE

The tests that have been selected are detailed in the customer Test Plan as defined in section 1.1 of this report. The Test Plan is based on the TÜV SÜD FCC Test Plan Rationale, available on request.



1.4 CONFIGURATION DESCRIPTION

Configuration A					
RAT	No. of Carriers	Carrier Bandwidth	Carrier Frequency Configuration (MHz)		
			Bottom	Middle	Top
LTE	1	5 MHz	2498.5	2593	2687.5
		10 MHz	2501	2593	2685
		15 MHz	2503.5	2593	2682.5
		20 MHz	2506	2593	2680
NR	1	10 MHz	2501	2593	2685
		15 MHz	2503.5	2593	2682.5
		20 MHz	2506	2593	2680
		30 MHz	2511	2593	2675
		40 MHz	2516	2593	2670
		50 MHz	2521	2593	2665
		60 MHz	2526	2593	2660
		70 MHz	2531	2593	2655
		80 MHz	2536	2593	2650
		90 MHz	2541	2593	2645
		100 MHz	2546	2593	2640

Configuration B Channel Allocations					
RAT	No. of Carriers	Carrier Bandwidth	Carrier Frequency Configuration (MHz)		
			Bottom	Middle	Top
LTE	2	5+5 MHz	2498.5+2503.5	2590.5+2595.5	2682.5+2687.5
		20+20 MHz	2506+2526	2583+2603	2660+2680
NR	2	10+10 MHz	2501+2511	2588+2598	2675+2685
		50+50 MHz	2521+2571	2568+2618	2615+2665
NR10+LTE5	2	10+5 MHz	2501+2508.5	2590.5+2598	2680+2687.5
* NR10+LTE5	2	10+5 MHz	2501+2593.5	--	2695+2687.5

Note: * - Non-Contiguous Configuration.



Configuration C Channel Allocations					
RAT	No. of Carriers	Carrier BW	Carrier Frequency Configuration (MHz)		
			Bottom	Middle	Top
LTE	6	5 MHz	2498.5+2503.5+2508.5	2580.5+2585.5+2590.5+	2662.5+2667.5+2672.5
			2513.5+2518.5+2523.5	2595.5+2600.5+2605.5	2677.5+2682.5+2687.5
		15 MHz	2503.5+2518.5+2533.5+	2555.5+2570.5+2585.5+	2607.5+2622.5+2637.5+
			2548.5+2563.5+2578.5	2600.5+2615.5+2630.5	2652.5+2667.5+2682.5
NR	6	10 MHz	2501+2511+2521+	2568+2578+2588+	2635+2645+2655+
			2531+2541+2551	2598+2608+2618	2665+2675+2685
NR	6	15 MHz	2503.5+2518.5+2533.5+	2555.5+2570.5+2585.5+	2607.5+2622.5+2637.5+
			2548.5+2563.5+2578.5	2600.5+2615.5+2630.5	2652.5+2667.5+2682.5
3NR10+3LTE5	6	10+5 MHz	2501+2511+2521+	2575.5+2585.5+2595.5+	2650+2660+2670+
			2528.5+2533.5+2538.5	2603+2608+2613	2677.5+2682.5+2687.5
* 3NR10+3LTE5	6	10+5 MHz	2501+2511+2521	--	2595+2605+2615
			2583.5+2588.5+2593.5	--	2677.5+2682.5+2687.5

Note: * - Non-Contiguous Configuration.



1.5 DECLARATION OF BUILD STATUS

MAIN EUT	
MANUFACTURING DESCRIPTION	Radio Dot
MANUFACTURER	Ericsson
TYPE	Remote Radio Base Station
PART NUMBER	KRY 901 551/1 and KRY 901 551/2
SERIAL NUMBER	E96A102435
HARDWARE VERSION	R1A
SOFTWARE VERSION	CXP 203 0045/26 - R17B569
TRANSMITTER OPERATING RANGE	B77D: 3700-3980MHz B77G: 3450-3550MHz B41: 2496-2690MHz
RECEIVER OPERATING RANGE	B77D: 3700-3980MHz B77G: 3450-3550MHz B41: 2496-2690MHz
COUNTRY OF ORIGIN	Poland
INTERMEDIATE FREQUENCIES	None
EMISSION DESIGNATOR(S): (i.e. G1D, GXW)	B77D NR: 10M0F9W, 15M0F9W, 20M0F9W, 30M0F9W, 40M0F9W, 50M0F9W, 60M0F9W, 70M0F9W 80M0F9W, 90M0F9W, 100MF9W B77G NR: 10M0F9W, 20M0F9W, 30M0F9W, 40M0F9W, 50M0F9W, 60M0F9W, 70M0F9W 80M0F9W, 90M0F9W, 100MF9W B41 NR: 10M0F9W, 15M0F9W, 20M0F9W, 30M0F9W, 40M0F9W, 50M0F9W, 60M0F9W, 70M0F9W 80M0F9W, 90M0F9W, 100MF9W B41 LTE: 5M00W7D, 10M0W7D, 15M0W7D, 20M0W7D
MODULATION TYPES: (i.e. GMSK, QPSK)	NR: QPSK, 16QAM, 64QAM, 256QAM LTE: QPSK, 16QAM, 64QAM, 256QAM
HIGHEST INTERNALLY GENERATED FREQUENCY	3.98 GHz
OUTPUT POWER (W or dBm)	B77D: 4 x 0.4W (26dBm) (1 carrier limited to 24dBm) B77G: 2 x 0.4W (26dBm) (1 carrier limited to 24dBm) B41: 2 x 0.4W (26dBm) (1 carrier limited to 24dBm)
Antenna gain (dBi)	B77D: 5.39 dBi B77G: 5.19 dBi B41: 5.65 dBi
FCC ID	TA8AKRY901551-1 & TA8AKRY901551-2
INDUSTRY CANADA ID	NA
TECHNICAL DESCRIPTION (a brief description of the intended use and operation)	Dot 4455 B77DB77GB41 (KRY 901 551/1) and Dot 4465 B77DB77GB41 (KRY 901 551/2) are Remote Radio Units forming part of the Ericsson Radio Base Station (RBS) equipment. The Dot provides radio access for mobile and fixed devices and is intended for the indoor environment. The radio operates over 8 Transmit ports in MRO (NR+LTE); Single, Multi-Carrier, and MIMO transmission with a maximum rated RF Output up to 0.4W per port over an operational temperature of 5°C to +40°C. The unit is designed to be ceiling or wall mounted. The 4455 and 4465 radios are identical except that Dot 4455 has internal antennas and Dot 4465 has external RF ports.



Signature 

.....

Denis Lalonde

Date: 9 August 2023

Declaration of Build Status Serial Number: E96A102435

No responsibility will be accepted by TÜV SÜD as to the accuracy of the information declared in this document by the manufacturer.



1.6 PRODUCT INFORMATION

1.6.1 Technical Description

The Equipment Under Test (EUT) Dot 4465 B77DB77GB41 KRY 901 515/2 is an Ericsson AB Radio Unit working in the public mobile service Band 41 band which provides communication connections to Band 41 network.

The EUT is declared as operating from a nominal -48V DC supply.

The Equipment Under Test (EUT) is shown in the photograph below. A full technical description can be found in the Manufacturer's documentation.

Equipment Under Test



1.7 TEST SETUP

Conducted Test Set Up – Band Edge, Conducted Emissions

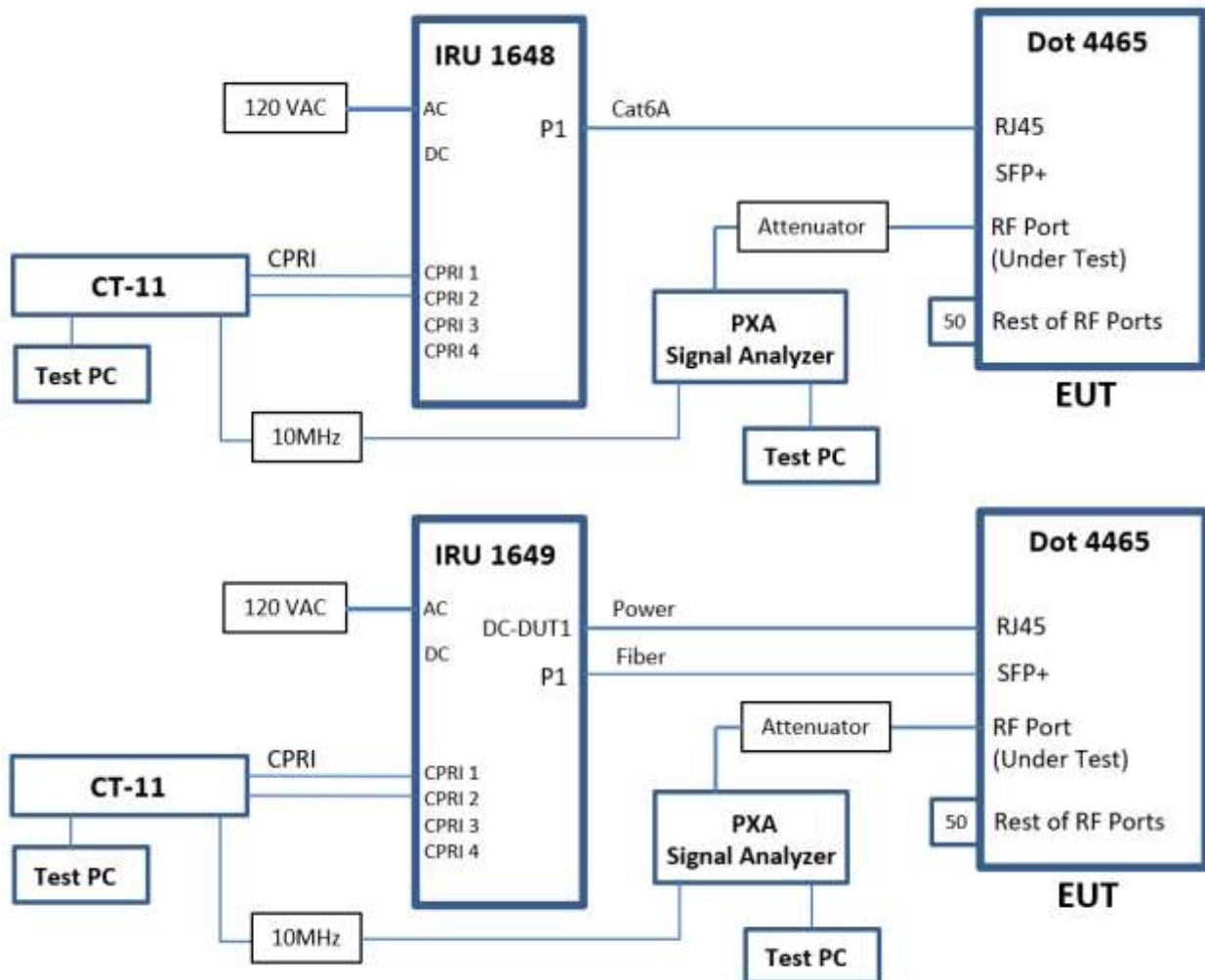

Conducted Test Set Up – Frequency Stability

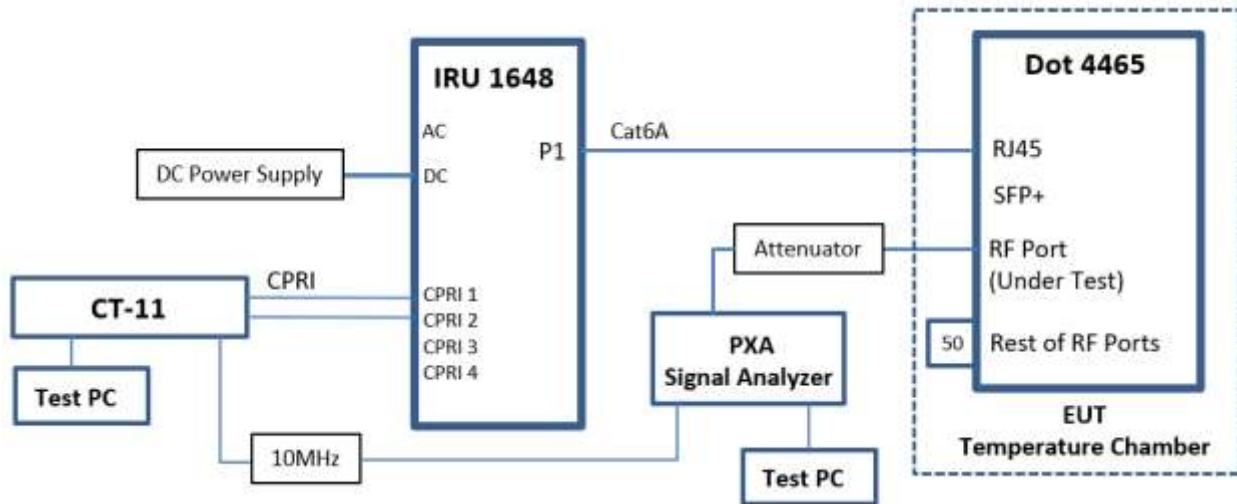



1.8 TEST CONDITIONS

For all tests the EUT was set up in accordance with the relevant test standard and to represent typical operating conditions. Tests were applied with the EUT situated as described in the Test Method for each Test.

The EUT was powered from a -54V DC supply unless otherwise stated.

FCC Measurement Facility Registration Number
CA4810 TUV SUD Ottawa, Canada, 1280 Teron Rd., Kanata On.

Under our A2LA Accreditation, TÜV SÜD Canada conducted the following tests Ericsson, Ottawa Laboratory, 349 Terry Fox Dr, Kanata, ON.

Test Name	Name of Engineer(s)
Maximum Peak Output Power and Peak to Average Ratio - Conducted	Glen Westwell
Band Edge	Glen Westwell
Transceiver Spurious Emissions	Glen Westwell
Frequency Stability	Glen Westwell

1.9 DEVIATION FROM THE STANDARD

No deviations from the applicable test standards or test plan were made during testing.

1.10 MODIFICATION RECORD

No modifications were made to the EUT during testing.

1.11 ADDITIONAL INFORMATION

1. This filing is for a Radio Certification for use in the USA under the following FCC ID's:

FCC ID: TA8AKRY901551-1 & TA8AKRY901551-2

2. Transmitter performance was measured for top, mid & bottom channels for contiguous and non-contiguous (NC) operation, where applicable, across all antenna ports as presented in the average power measurement tables. Typical performance is presented. All configuration data is on file and available upon request.

3. The Dot 4455 B77DB77GB41 and Dot 4465 B77DB77GB41 radios are identical except that Dot 4455 has internal antennas and Dot 4465 has external RF ports.



SECTION 2

TEST DETAILS



2.1 MAXIMUM PEAK OUTPUT POWER AND PEAK TO AVERAGE RATIO - CONDUCTED

2.1.1 Specification Reference

FCC CFR 47 Part 27, Clause 27.50

2.1.2 Date of Test and Modification State

08 and 09-August-2023 - Modification State 0

2.1.3 Test Equipment Used

The major items of test equipment used for the above tests are identified in Section 3.1.

2.1.4 Environmental Conditions

Ambient Temperature	24.7 - 25.0°C
Relative Humidity	31.7 - 33.1%

2.1.5 Test Method

All measurements were made in accordance with FCC KDB 971168 D01, clause 5.2.1 and summed in accordance with FCC KDB 662911 D01.

2.1.6 Test Results



Configuration A

Maximum Output Power 24.00 dBm / Port

Antenna Gain (dBi)	Modulation	Carrier Bandwidth	Peak to Average Ratio (PAR) / Output Power					
			Antenna Port	PAR (dB)	Channel Position B			
					Average Power			
5.65				dBm	EIRP (dBm)	dBm/MHz	EIRP dBm/MHz	
1A	LTE: QPSK	5.0 MHz	10.22	23.28	28.93	16.71	22.36	
1B	LTE: QPSK	5.0 MHz	-	23.41	29.06	16.71	22.36	
Total			-	26.36	32.01	19.72	25.37	
1A	LTE: QPSK	10.0 MHz	10.00	23.44	29.09	14.01	19.66	
1B	LTE: QPSK	10.0 MHz	-	23.56	29.21	14.01	19.66	
Total			-	26.51	32.16	17.02	22.67	
1A	LTE: QPSK	15.0 MHz	10.39	23.66	29.31	12.72	18.37	
1B	LTE: QPSK	15.0 MHz	-	23.81	29.46	12.72	18.37	
Total			-	26.75	32.40	15.73	21.38	
1A	LTE: QPSK	20.0 MHz	10.21	23.58	29.23	11.31	16.96	
1B	LTE: QPSK	20.0 MHz	-	23.75	29.40	11.31	16.96	
Total			-	26.68	32.33	14.32	19.97	
1A	NR: QPSK	10.0 MHz	9.77	24.11	29.76	14.70	20.35	
1B	NR: QPSK	10.0 MHz	-	24.20	29.85	14.70	20.35	
Total			-	27.17	32.82	17.71	23.36	
1A	NR: QPSK	15.0 MHz	9.33	24.08	29.73	13.01	18.66	
1B	NR: QPSK	15.0 MHz	-	24.34	29.99	13.01	18.66	
Total			-	27.22	32.87	16.02	21.67	
1A	NR: QPSK	20.0 MHz	9.53	23.88	29.53	11.67	17.32	
1B	NR: QPSK	20.0 MHz	-	23.97	29.62	11.67	17.32	
Total			-	26.94	32.59	14.68	20.33	
1A	NR: QPSK	30.0 MHz	9.60	23.77	29.42	9.87	15.52	
1B	NR: QPSK	30.0 MHz	-	23.92	29.57	9.87	15.52	
Total			-	26.86	32.51	12.88	18.53	
1A	NR: QPSK	40.0 MHz	9.76	23.78	29.43	8.44	14.09	
1B	NR: QPSK	40.0 MHz	-	23.90	29.55	8.44	14.09	
Total			-	26.85	32.50	11.45	17.10	
1A	NR: QPSK	50.0 MHz	9.54	24.23	29.88	7.90	13.55	
1B	NR: QPSK	50.0 MHz	-	24.37	30.02	7.90	13.55	
Total			-	27.31	32.96	10.91	16.56	
1A	NR: QPSK	60.0 MHz	9.46	24.17	29.82	6.96	12.61	
1B	NR: QPSK	60.0 MHz	-	24.34	29.99	6.96	12.61	
Total			-	27.27	32.92	9.97	15.62	
1A	NR: QPSK	70.0 MHz	9.74	24.10	29.75	6.30	11.95	
1B	NR: QPSK	70.0 MHz	-	24.39	30.04	6.30	11.95	
Total			-	27.26	32.91	9.31	14.96	
1A	NR: QPSK	80.0 MHz	9.56	24.10	29.75	5.66	11.31	
1B	NR: QPSK	80.0 MHz	-	24.28	29.93	5.66	11.31	
Total			-	27.20	32.85	8.67	14.32	
1A	NR: QPSK	90.0 MHz	9.53	23.61	29.26	4.78	10.43	
1B	NR: QPSK	90.0 MHz	-	23.73	29.38	4.78	10.43	
Total			-	26.68	32.33	7.79	13.44	
1A	NR: QPSK	100.0 MHz	9.36	23.75	29.40	4.08	9.73	
1B	NR: QPSK	100.0 MHz	-	23.80	29.45	4.08	9.73	
Total			-	26.79	32.44	7.09	12.74	



Antenna Gain (dBi)	Modulation	Carrier Bandwidth	Peak to Average Ratio (PAR) / Output Power					
			Antenna Port	PAR (dB)	Channel Position M			
					Average Power			
5.65				dBm	EIRP (dBm)	dBm/MHz	EIRP dBm/MHz	
1A	LTE: QPSK	5.0 MHz	9.38	23.26	28.91	16.95	22.60	
1B	LTE: QPSK	5.0 MHz	-	23.68	29.33	16.95	22.60	
Total			-	26.49	32.14	19.96	25.61	
1A	LTE: QPSK	10.0 MHz	10.28	23.47	29.12	13.88	19.53	
1B	LTE: QPSK	10.0 MHz	-	23.71	29.36	13.88	19.53	
Total			-	26.60	32.25	16.89	22.54	
1A	LTE: QPSK	15.0 MHz	9.73	23.44	29.09	12.52	18.17	
1B	LTE: QPSK	15.0 MHz	-	23.75	29.40	12.52	18.17	
Total			-	26.61	32.26	15.53	21.18	
1A	LTE: QPSK	20.0 MHz	10.50	23.57	29.22	11.28	16.93	
1B	LTE: QPSK	20.0 MHz	-	23.70	29.35	11.28	16.93	
Total			-	26.65	32.30	14.29	19.94	
1A	NR: QPSK	10.0 MHz	9.63	23.85	29.50	14.47	20.12	
1B	NR: QPSK	10.0 MHz	-	24.14	29.79	14.47	20.12	
Total			-	27.01	32.66	17.48	23.13	
1A	NR: QPSK	15.0 MHz	9.52	23.77	29.42	12.60	18.25	
1B	NR: QPSK	15.0 MHz	-	24.33	29.98	12.60	18.25	
Total			-	27.07	32.72	15.61	21.26	
1A	NR: QPSK	20.0 MHz	9.34	23.80	29.45	11.45	17.10	
1B	NR: QPSK	20.0 MHz	-	23.99	29.64	11.45	17.10	
Total			-	26.91	32.56	14.46	20.11	
1A	NR: QPSK	30.0 MHz	9.29	23.74	29.39	9.64	15.29	
1B	NR: QPSK	30.0 MHz	-	24.00	29.65	9.64	15.29	
Total			-	26.88	32.53	12.65	18.30	
1A	NR: QPSK	40.0 MHz	9.40	23.66	29.31	8.23	13.88	
1B	NR: QPSK	40.0 MHz	-	23.91	29.56	8.23	13.88	
Total			-	26.80	32.45	11.24	16.89	
1A	NR: QPSK	50.0 MHz	9.13	24.17	29.82	7.58	13.23	
1B	NR: QPSK	50.0 MHz	-	24.38	30.03	7.58	13.23	
Total			-	27.29	32.94	10.59	16.24	
1A	NR: QPSK	60.0 MHz	9.53	24.19	29.84	6.83	12.48	
1B	NR: QPSK	60.0 MHz	-	24.28	29.93	6.83	12.48	
Total			-	27.25	32.90	9.84	15.49	
1A	NR: QPSK	70.0 MHz	9.51	24.22	29.87	6.22	11.87	
1B	NR: QPSK	70.0 MHz	-	24.38	30.03	6.22	11.87	
Total			-	27.31	32.96	9.23	14.88	
1A	NR: QPSK	80.0 MHz	9.28	24.26	29.91	5.38	11.03	
1B	NR: QPSK	80.0 MHz	-	24.35	30.00	5.38	11.03	
Total			-	27.32	32.97	8.39	14.04	
	NR: QPSK	90.0 MHz	9.82	23.55	29.20	4.52	10.17	
1B	NR: QPSK	90.0 MHz	-	23.76	29.41	4.52	10.17	
Total			-	26.67	32.32	7.53	13.18	
1A	NR: QPSK	100.0 MHz	9.38	23.48	29.13	4.30	9.95	
1B	NR: QPSK	100.0 MHz	-	23.84	29.49	4.30	9.95	
Total			-	26.67	32.32	7.31	12.96	



Antenna Gain (dBi)	Modulation	Carrier Bandwidth	Peak to Average Ratio (PAR) / Output Power				
			Channel Position T				
			PAR (dB)	Average Power			
dBm	EIRP (dBm)	dBm/MHz		EIRP dBm/MHz			
5.65							
Antenna Port							
1A	LTE: QPSK	5.0 MHz	8.33	23.34	28.99	16.82	22.47
1B	LTE: QPSK	5.0 MHz	-	23.45	29.10	16.82	22.47
Total			-	26.41	32.06	19.83	25.48
1A	LTE: QPSK	10.0 MHz	9.45	23.41	29.06	14.15	19.80
1B	LTE: QPSK	10.0 MHz	-	23.57	29.22	14.15	19.80
Total			-	26.50	32.15	17.16	22.81
1A	LTE: QPSK	15.0 MHz	10.40	23.12	28.77	12.50	18.15
1B	LTE: QPSK	15.0 MHz	-	23.40	29.05	12.50	18.15
Total			-	26.27	31.92	15.51	21.16
1A	LTE: QPSK	20.0 MHz	9.11	23.65	29.30	11.49	17.14
1B	LTE: QPSK	20.0 MHz	-	23.66	29.31	11.49	17.14
Total			-	26.67	32.32	14.50	20.15
1A	NR: QPSK	10.0 MHz	9.71	24.02	29.67	14.59	20.24
1B	NR: QPSK	10.0 MHz	-	24.08	29.73	14.59	20.24
Total			-	27.06	32.71	17.60	23.25
1A	NR: QPSK	15.0 MHz	9.68	23.39	29.04	12.71	18.36
1B	NR: QPSK	15.0 MHz	-	24.02	29.67	12.71	18.36
Total			-	26.73	32.38	15.72	21.37
1A	NR: QPSK	20.0 MHz	9.53	23.85	29.50	11.58	17.23
1B	NR: QPSK	20.0 MHz	-	23.87	29.52	11.58	17.23
Total			-	26.87	32.52	14.59	20.24
1A	NR: QPSK	30.0 MHz	9.50	23.80	29.45	9.81	15.46
1B	NR: QPSK	30.0 MHz	-	23.94	29.59	9.81	15.46
Total			-	26.88	32.53	12.82	18.47
1A	NR: QPSK	40.0 MHz	9.53	24.23	29.88	8.94	14.59
1B	NR: QPSK	40.0 MHz	-	24.29	29.94	8.94	14.59
Total			-	27.27	32.92	11.95	17.60
1A	NR: QPSK	50.0 MHz	9.69	24.11	29.76	7.98	13.63
1B	NR: QPSK	50.0 MHz	-	24.29	29.94	7.98	13.63
Total			-	27.21	32.86	10.99	16.64
1A	NR: QPSK	60.0 MHz	9.33	24.14	29.79	7.10	12.75
1B	NR: QPSK	60.0 MHz	-	24.38	30.03	7.10	12.75
Total			-	27.27	32.92	10.11	15.76
1A	NR: QPSK	70.0 MHz	9.52	24.20	29.85	6.44	12.09
1B	NR: QPSK	70.0 MHz	-	24.29	29.94	6.44	12.09
Total			-	27.26	32.91	9.45	15.10
1A	NR: QPSK	80.0 MHz	9.62	24.14	29.79	5.78	11.43
1B	NR: QPSK	80.0 MHz	-	24.31	29.96	5.78	11.43
Total			-	27.24	32.89	8.79	14.44
	NR: QPSK	90.0 MHz	9.57	23.57	29.22	4.89	10.54
1B	NR: QPSK	90.0 MHz	-	23.95	29.60	4.89	10.54
Total			-	26.77	32.42	7.90	13.55
1A	NR: QPSK	100.0 MHz	9.17	23.63	29.28	4.26	9.91
1B	NR: QPSK	100.0 MHz	-	23.85	29.50	4.26	9.91
Total			-	26.75	32.40	7.27	12.92

Remarks

1. Transmitter performance has been presented for top, mid, bottom channels across all antenna ports as represented in the following tables. 2. Typical performance and measurement plot data has been presented for reference. 3. All plot data is on file and available upon request.

Antenna Port A Carrier Power - Modulation LTE: QPSK - Carrier Bandwidth 5.0 MHz - Channel Position B



Antenna Port A Pk-Av Ratio - Modulation LTE: QPSK - Carrier Bandwidth 5.0 MHz - Channel Position B

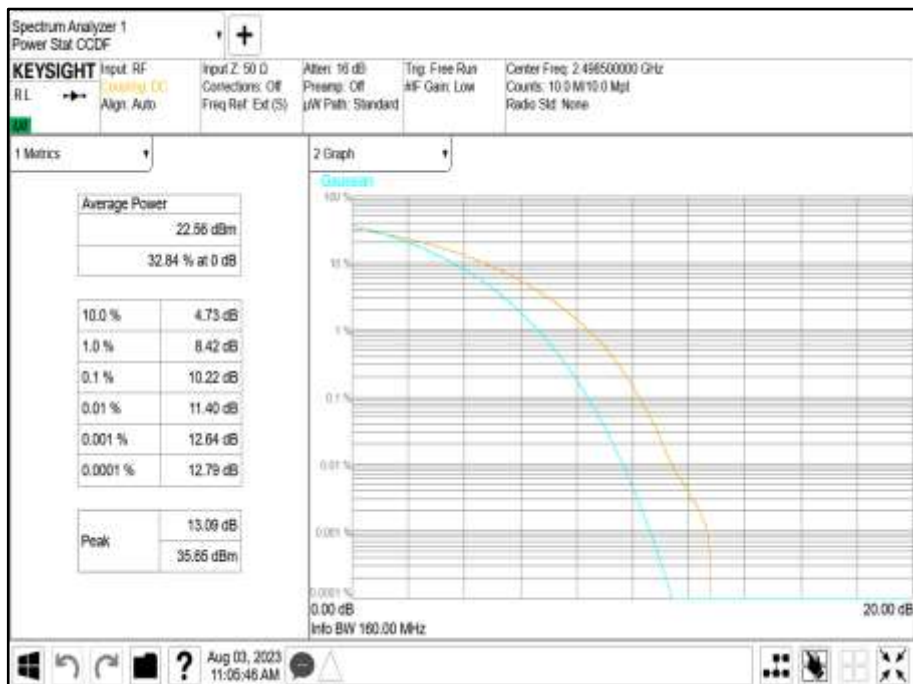

Antenna Port A PSD - Modulation LTE: QPSK - Carrier Bandwidth 5.0 MHz - Channel Position B



Antenna Port A Carrier Power - Modulation LTE: QPSK - Carrier Bandwidth 10.0 MHz - Channel Position B



Antenna Port A Pk-Av Ratio - Modulation LTE: QPSK - Carrier Bandwidth 10.0 MHz - Channel Position B



Antenna Port A PSD - Modulation LTE: QPSK - Carrier Bandwidth 10.0 MHz - Channel Position B

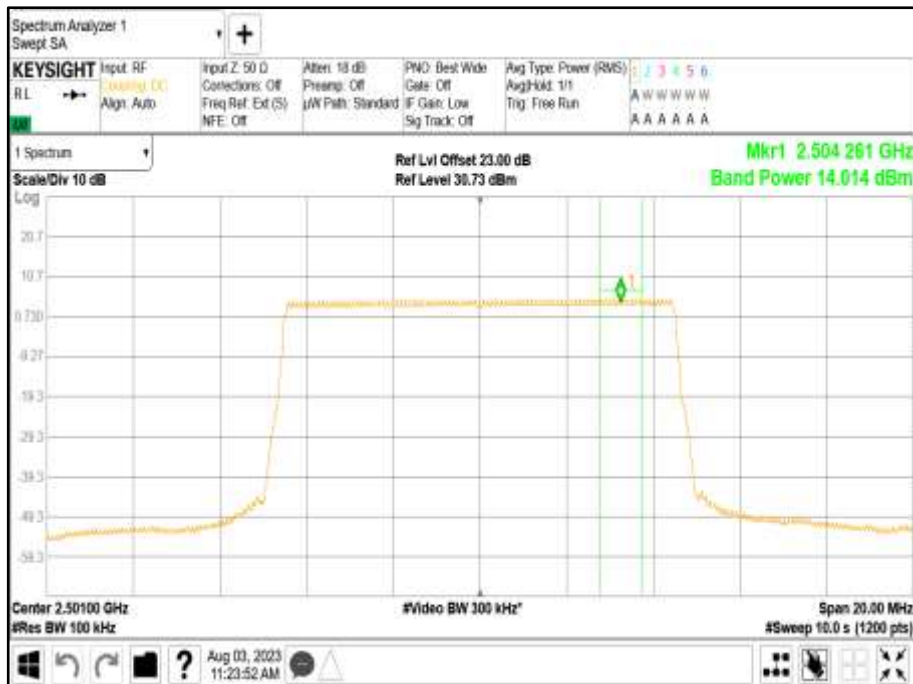

Antenna Port A Carrier Power - Modulation LTE: QPSK - Carrier Bandwidth 15.0 MHz - Channel Position B



Antenna Port A Pk-Av Ratio - Modulation LTE: QPSK - Carrier Bandwidth 15.0 MHz - Channel Position B



Antenna Port A PSD - Modulation LTE: QPSK - Carrier Bandwidth 15.0 MHz - Channel Position B

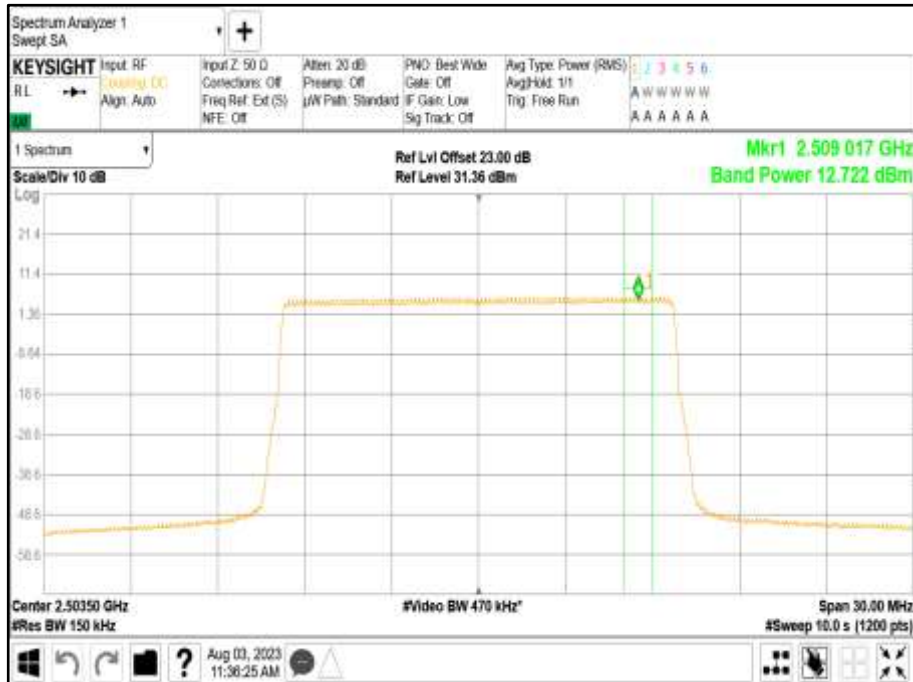

Antenna Port A Carrier Power - Modulation LTE: QPSK - Carrier Bandwidth 20.0 MHz - Channel Position B



Antenna Port A Pk-Av Ratio - Modulation LTE: QPSK - Carrier Bandwidth 20.0 MHz - Channel Position B

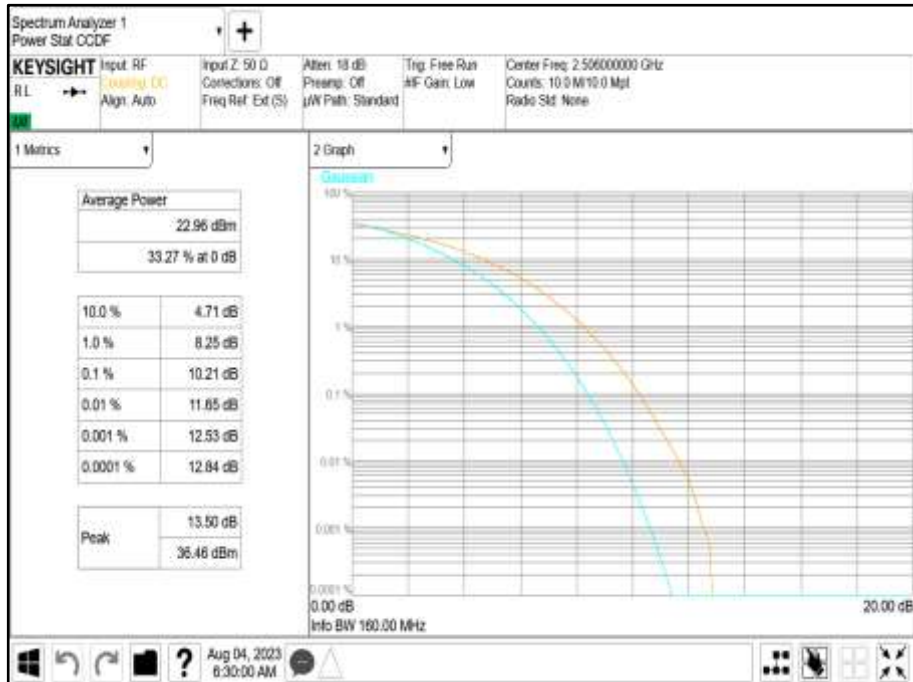

Antenna Port A PSD - Modulation LTE: QPSK - Carrier Bandwidth 20.0 MHz - Channel Position B





Antenna Port A Carrier Power - Modulation NR: QPSK - Carrier Bandwidth 10.0 MHz - Channel Position B



Antenna Port A Pk-Av Ratio - Modulation NR: QPSK - Carrier Bandwidth 10.0 MHz - Channel Position B

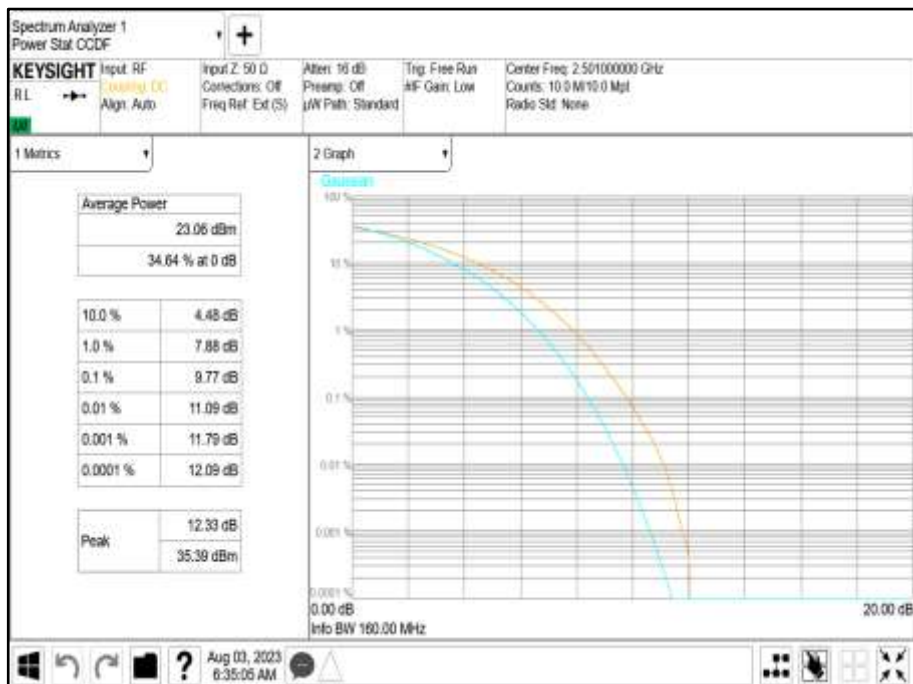

Antenna Port A PSD - Modulation NR: QPSK - Carrier Bandwidth 10.0 MHz - Channel Position B



Antenna Port A Carrier Power - Modulation NR: QPSK - Carrier Bandwidth 15.0 MHz - Channel Position B



Antenna Port A Pk-Av Ratio - Modulation NR: QPSK - Carrier Bandwidth 15.0 MHz - Channel Position B



Antenna Port A PSD - Modulation NR: QPSK - Carrier Bandwidth 15.0 MHz - Channel Position B





Antenna Port A Carrier Power - Modulation NR: QPSK - Carrier Bandwidth 20.0 MHz - Channel Position B



Antenna Port A Pk-Av Ratio - Modulation NR: QPSK - Carrier Bandwidth 20.0 MHz - Channel Position B

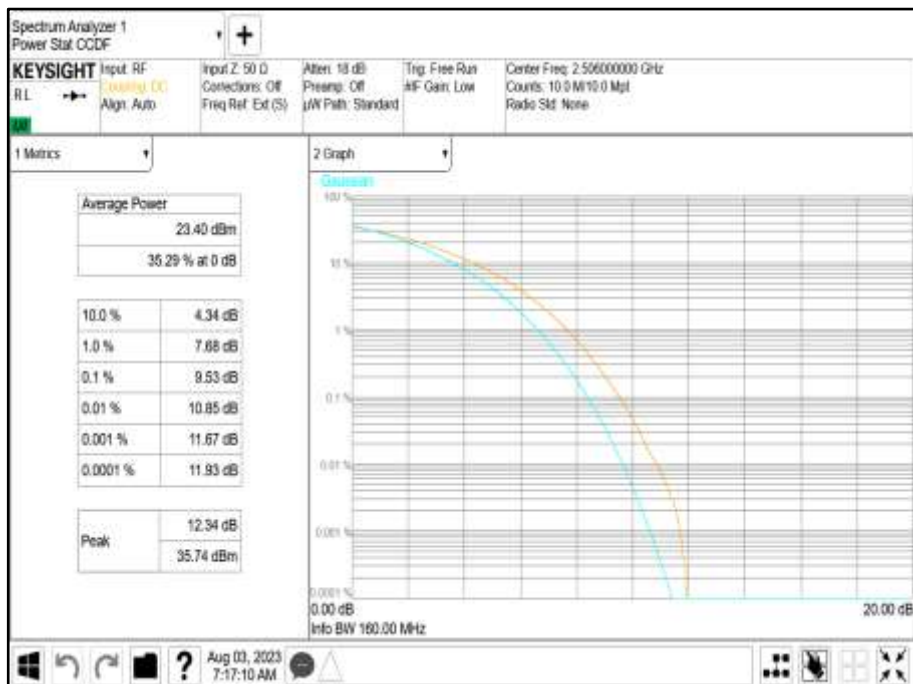

Antenna Port A PSD - Modulation NR: QPSK - Carrier Bandwidth 20.0 MHz - Channel Position B



Antenna Port A Carrier Power - Modulation NR: QPSK - Carrier Bandwidth 30.0 MHz - Channel Position B

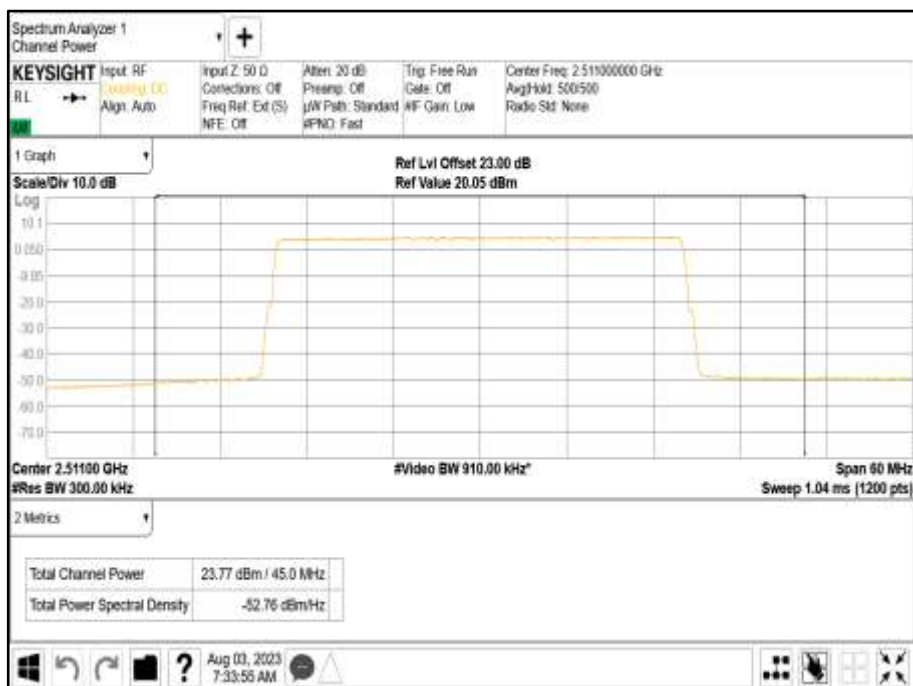

Antenna Port A Pk-Av Ratio - Modulation NR: QPSK - Carrier Bandwidth 30.0 MHz - Channel Position B



Antenna Port A PSD - Modulation NR: QPSK - Carrier Bandwidth 30.0 MHz - Channel Position B





Antenna Port A Carrier Power - Modulation NR: QPSK - Carrier Bandwidth 40.0 MHz - Channel Position B



Antenna Port A Pk-Av Ratio - Modulation NR: QPSK - Carrier Bandwidth 40.0 MHz - Channel Position B

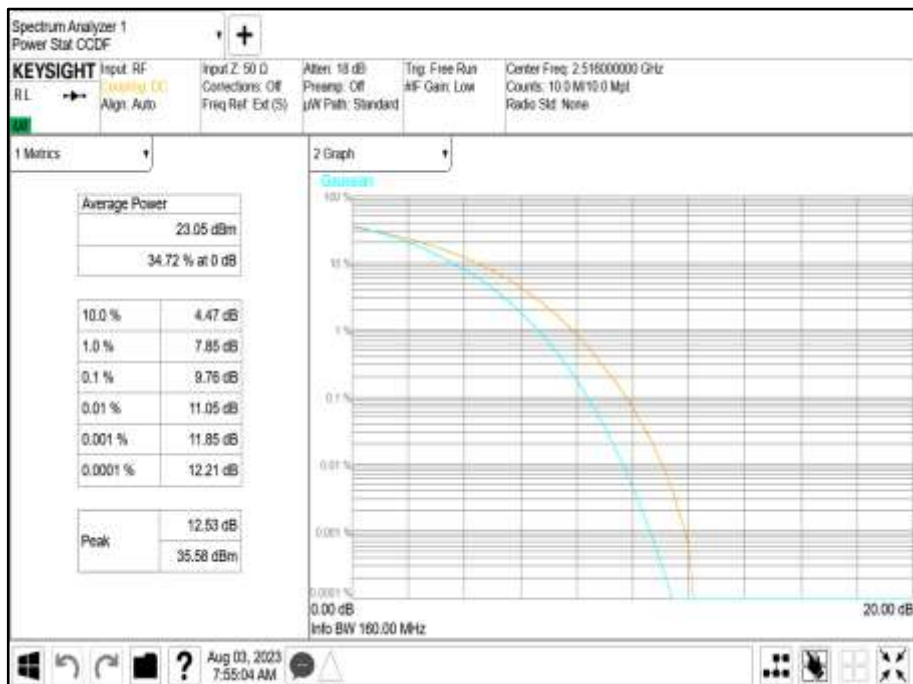

Antenna Port A PSD - Modulation NR: QPSK - Carrier Bandwidth 40.0 MHz - Channel Position B



Antenna Port A Carrier Power - Modulation NR: QPSK - Carrier Bandwidth 50.0 MHz - Channel Position B



Antenna Port A Pk-Av Ratio - Modulation NR: QPSK - Carrier Bandwidth 50.0 MHz - Channel Position B

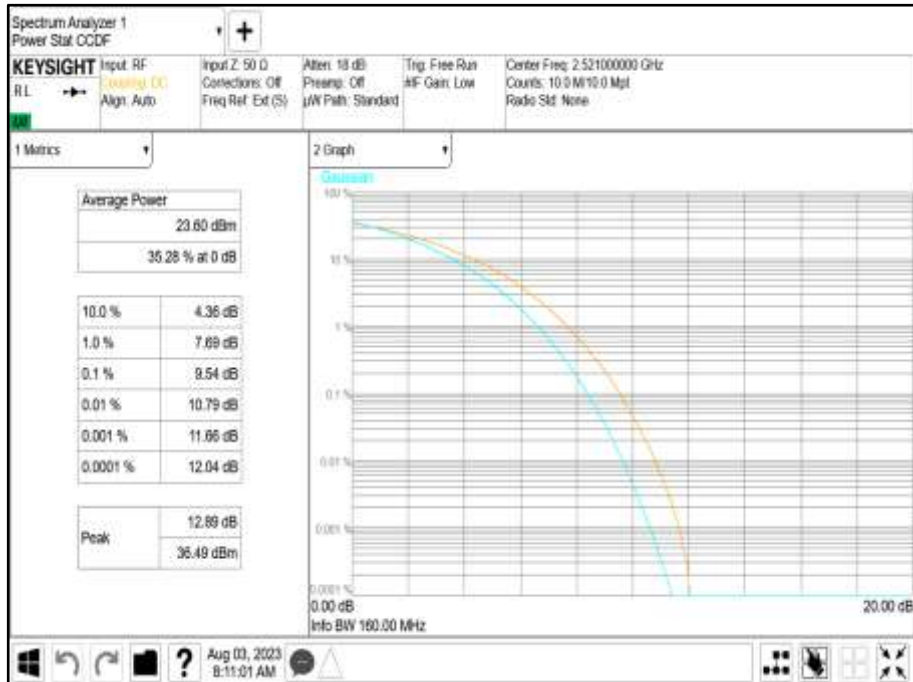

Antenna Port A PSD - Modulation NR: QPSK - Carrier Bandwidth 50.0 MHz - Channel Position B

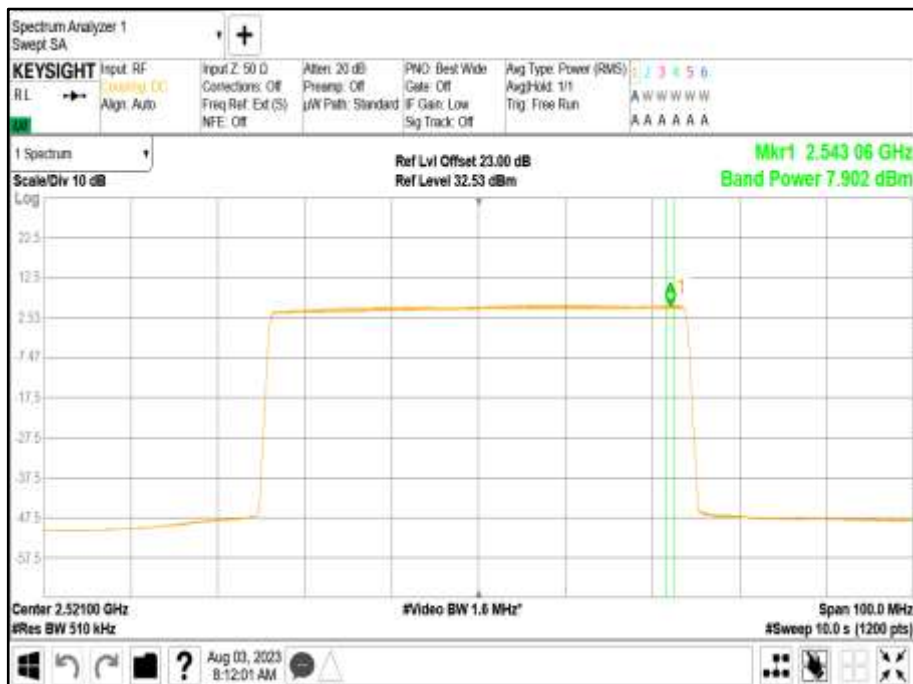



Antenna Port A Carrier Power - Modulation NR: QPSK - Carrier Bandwidth 60.0 MHz - Channel Position B



Antenna Port A Pk-Av Ratio - Modulation NR: QPSK - Carrier Bandwidth 60.0 MHz - Channel Position B

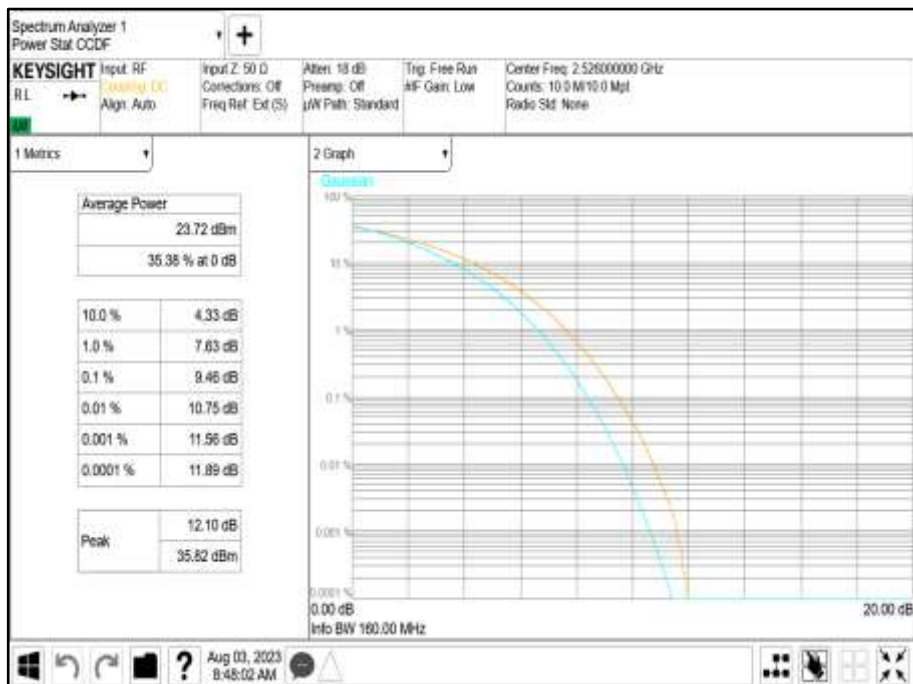

Antenna Port A PSD - Modulation NR: QPSK - Carrier Bandwidth 60.0 MHz - Channel Position B



Antenna Port A Carrier Power - Modulation NR: QPSK - Carrier Bandwidth 70.0 MHz - Channel Position B



Antenna Port A Pk-Av Ratio - Modulation NR: QPSK - Carrier Bandwidth 70.0 MHz - Channel Position B

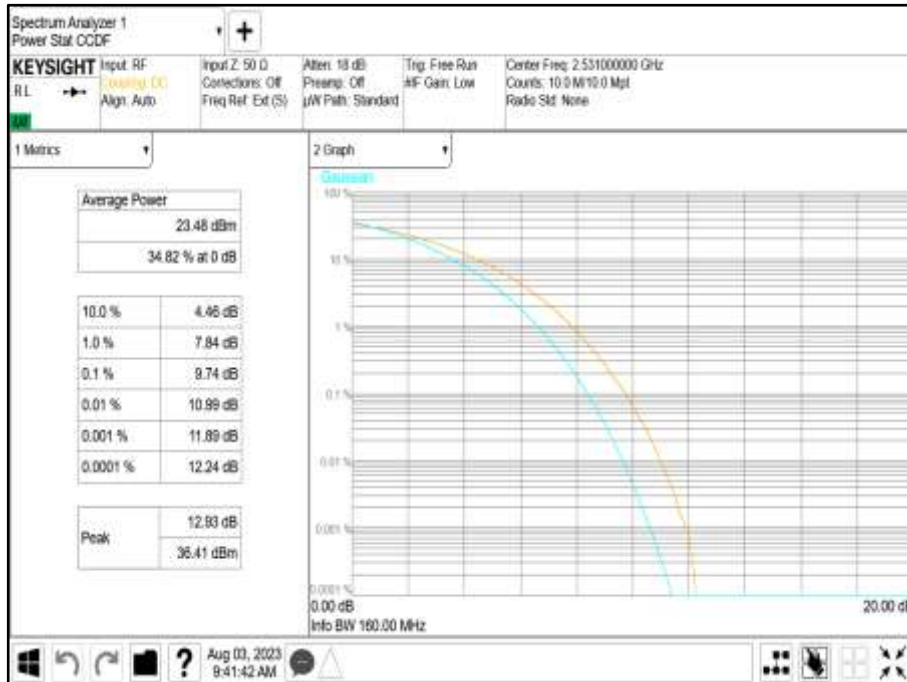

Antenna Port A PSD - Modulation NR: QPSK - Carrier Bandwidth 70.0 MHz - Channel Position B





Antenna Port A Carrier Power - Modulation NR: QPSK - Carrier Bandwidth 80.0 MHz - Channel Position B



Antenna Port A Pk-Av Ratio - Modulation NR: QPSK - Carrier Bandwidth 80.0 MHz - Channel Position B

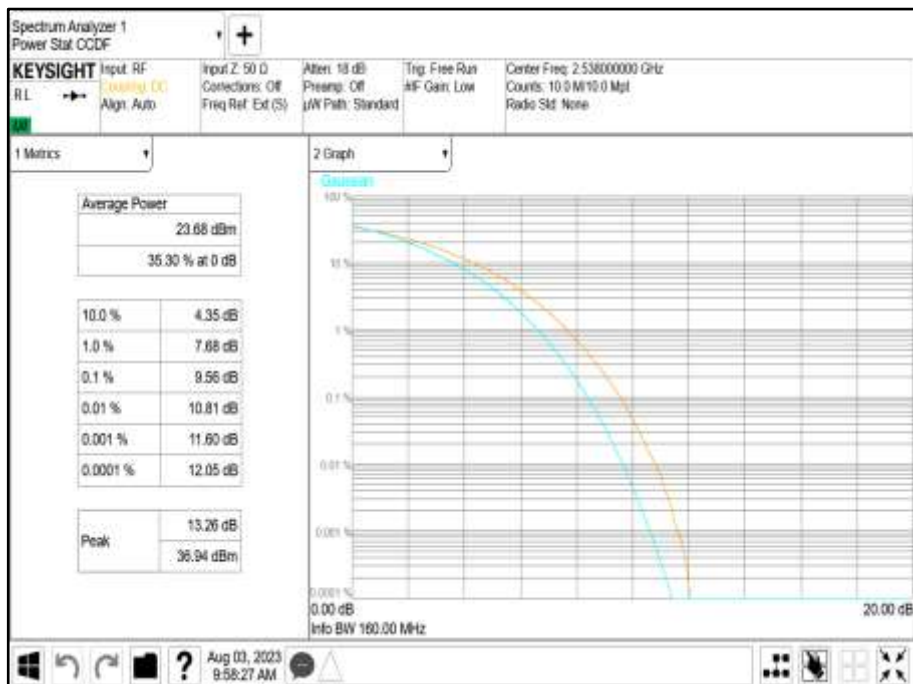

Antenna Port A PSD - Modulation NR: QPSK - Carrier Bandwidth 80.0 MHz - Channel Position B



Antenna Port A Carrier Power - Modulation NR: QPSK - Carrier Bandwidth 90.0 MHz - Channel Position B



Antenna Port A Carrier Power - Modulation NR: QPSK - Carrier Bandwidth 100.0 MHz - Channel Position B



Antenna Port A Pk-Av Ratio - Modulation NR: QPSK - Carrier Bandwidth 100.0 MHz - Channel Position B

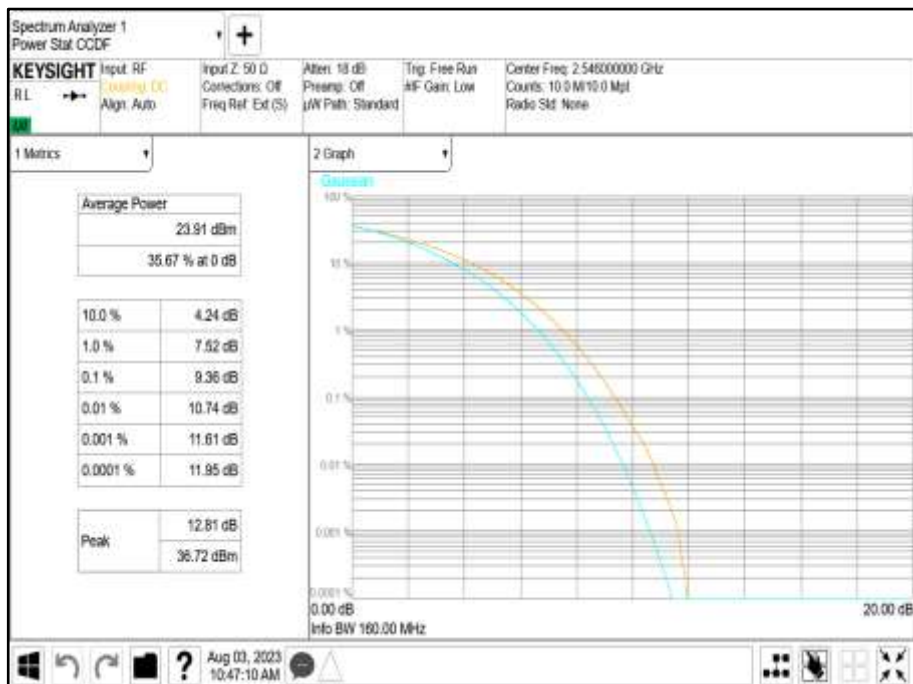



Antenna Port A PSD - Modulation NR: QPSK - Carrier Bandwidth 100.0 MHz - Channel Position B





Configuration B

Maximum Output Power 26.00 dBm / Port

Antenna Gain (dBi) 5.65	Modulation	Carrier Bandwidth	Output Power	
			Channel Position B	
			Average Power (dBm)	
Antenna Port			dBm	EIRP (dBm)
1A	LTE5: QPSK	L5.0+L5.0 MHz	25.47	31.12
1B	LTE5: QPSK	L5.0+L5.0 MHz	25.63	31.28
Total			28.56	34.21
1A	LTE20: QPSK	L20.0+L20.0 MHz	25.67	31.32
1B	LTE20: QPSK	L20.0+L20.0 MHz	25.41	31.06
Total			28.55	34.20
1A	NR10: QPSK	NR10+NR10 MHz	25.91	31.56
1B	NR10: QPSK	NR10+NR10 MHz	26.00	31.65
Total			28.97	34.62
1A	NR50: QPSK	NR50+NR50 MHz	25.61	31.26
1B	NR50: QPSK	NR50+NR50 MHz	25.83	31.48
Total			28.73	34.38
1A	NR10+LTE5: QPSK	NR10+L5 MHz	25.99	31.64
1B	NR10+LTE5: QPSK	NR10+L5 MHz	26.00	31.65
Total			29.01	34.66
1A	* NR10+LTE5: QPSK	* NR10+L5 MHz	25.47	31.12
1B	* NR10+LTE5: QPSK	* NR10+L5 MHz	25.66	31.31
Total			28.58	34.23

Antenna Gain (dBi) 5.65	Modulation	Carrier Bandwidth	Output Power	
			Channel Position M	
			Average Power (dBm)	
Antenna Port			dBm	EIRP (dBm)
1A	LTE5: QPSK	L5.0+L5.0 MHz	25.57	31.22
1B	LTE5: QPSK	L5.0+L5.0 MHz	25.71	31.36
Total			28.65	34.30
1A	LTE20: QPSK	L20.0+L20.0 MHz	25.49	31.14
1B	LTE20: QPSK	L20.0+L20.0 MHz	25.45	31.10
Total			28.48	34.13
1A	NR10: QPSK	NR10+NR10 MHz	25.88	31.53
1B	NR10: QPSK	NR10+NR10 MHz	26.01	31.66
Total			28.96	34.61
1A	NR50: QPSK	NR50+NR50 MHz	25.53	31.18
1B	NR50: QPSK	NR50+NR50 MHz	25.77	31.42
Total			28.66	34.31
1A	NR10+LTE5: QPSK	NR10+L5 MHz	25.99	31.64
1B	NR10+LTE5: QPSK	NR10+L5 MHz	26.11	31.76
Total			29.06	34.71
1A	* NR10+LTE5: QPSK	* NR10+L5 MHz	-	-
1B	* NR10+LTE5: QPSK	* NR10+L5 MHz	-	-
Total			-	-



Antenna Gain (dBi)	Modulation	Carrier Bandwidth	Output Power	
			Channel Position T	
			Average Power (dBm)	
Antenna Port			dBm	EIRP (dBm)
5.65				
1A	LTE5: QPSK	L5.0+L5.0 MHz	25.42	31.07
1B	LTE5: QPSK	L5.0+L5.0 MHz	25.61	31.26
Total			28.65	34.30
1A	LTE20: QPSK	L20.0+L20.0 MHz	25.28	30.93
1B	LTE20: QPSK	L20.0+L20.0 MHz	25.42	31.07
Total			28.48	34.13
1A	NR10: QPSK	NR10+NR10 MHz	25.74	31.39
1B	NR10: QPSK	NR10+NR10 MHz	26.08	31.73
Total			28.96	34.61
1A	NR50: QPSK	NR50+NR50 MHz	25.70	31.35
1B	NR50: QPSK	NR50+NR50 MHz	25.83	31.48
Total			28.66	34.31
1A	NR10+LTE5: QPSK	NR10+L5 MHz	25.85	31.50
1B	NR10+LTE5: QPSK	NR10+L5 MHz	26.01	31.66
Total			29.06	34.71
1A	* NR10+LTE5: QPSK	* NR10+L5 MHz	25.61	31.26
1B	* NR10+LTE5: QPSK	* NR10+L5 MHz	25.72	31.37
Total			28.68	34.33

Remarks

1. The table results are measured at all antenna ports, worst-case performance presented. 2. The plot results represent typical radio performance across all channels. 3. Plot data performance for all transmitter ports and channels are available on request. 4 * indicates a Non-Contiguous (NC) configuration.



Antenna Port A Carrier Power - Modulation LTE5: QPSK - Carrier Bandwidth L5.0+L5.0 MHz - Channel Position B

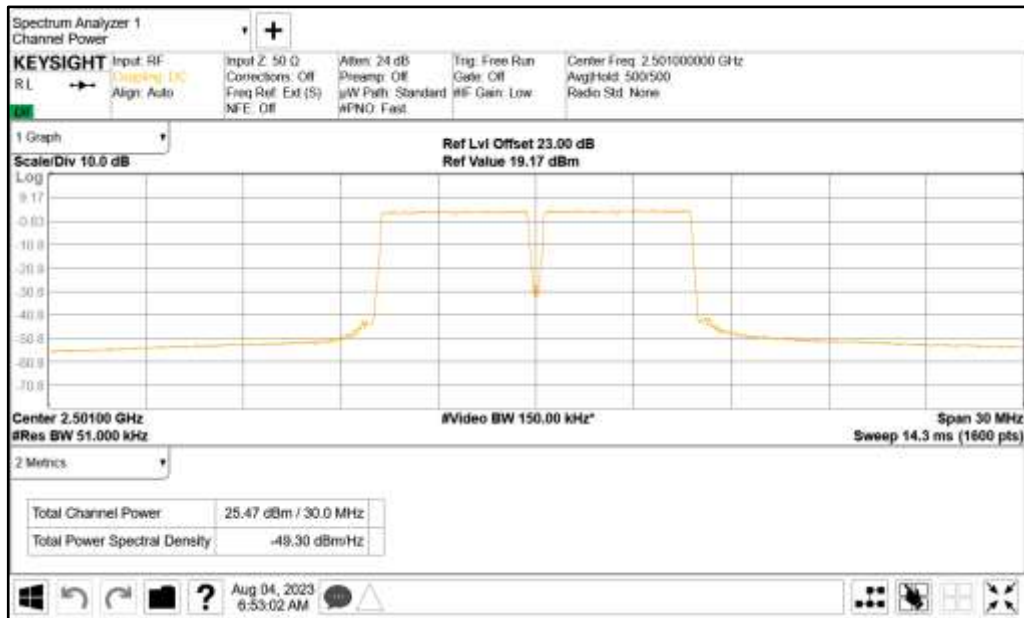

Antenna Port A Carrier Power - Modulation LTE20: QPSK - Carrier Bandwidth L20.0+L20.0 MHz - Channel Position B

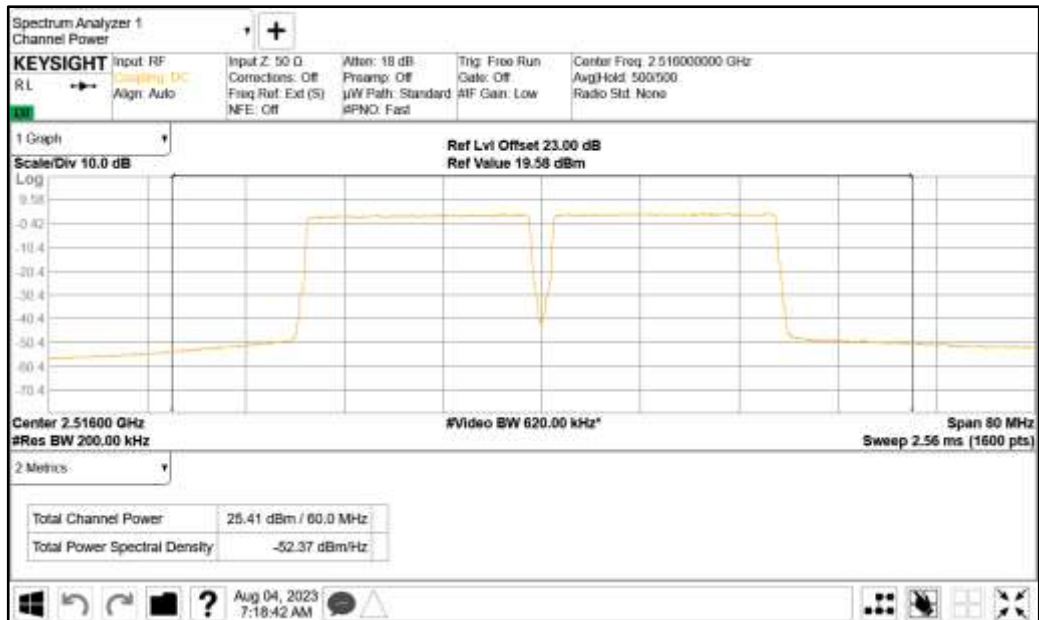



Antenna Port A Carrier Power - Modulation NR10: QPSK - Carrier Bandwidth NR10+NR10 MHz - Channel Position B

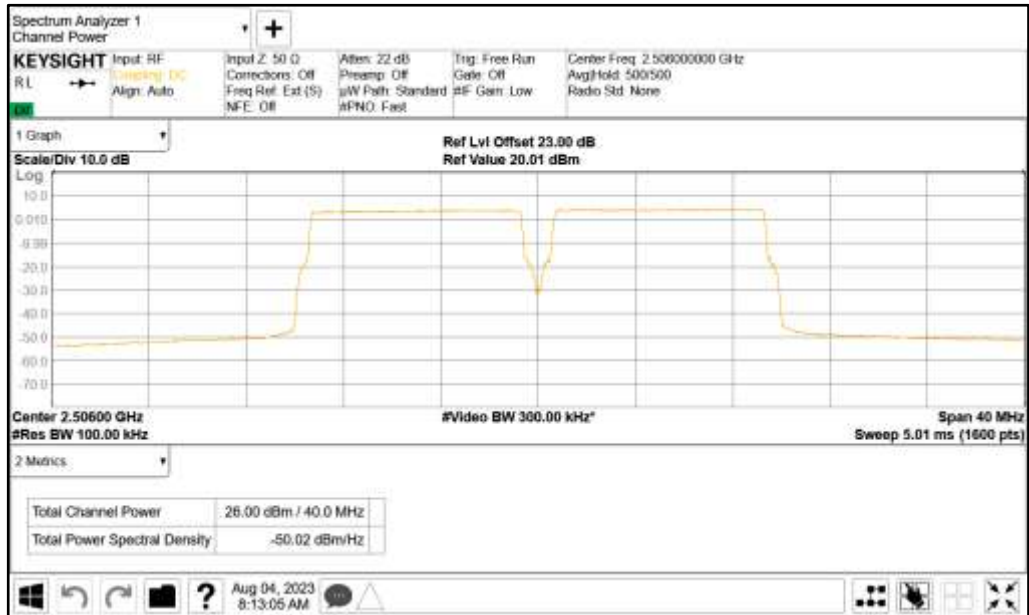

Antenna Port A Carrier Power - Modulation NR90: QPSK - Carrier Bandwidth NR50+NR50 MHz - Channel Position B





Antenna Port A Carrier Power - Modulation NR10+LTE5: QPSK - Carrier Bandwidth NR10+L5 MHz - Channel Position B

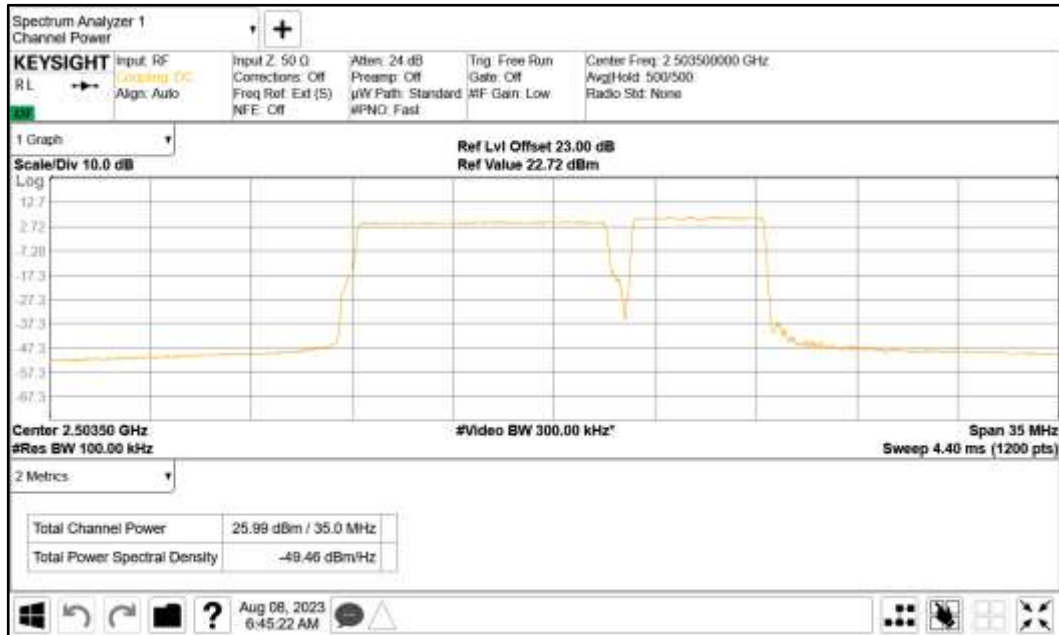

Antenna Port A Carrier Power - Modulation * NR10+LTE5: QPSK - Carrier Bandwidth *NR10+L5 MHz - Channel Position B

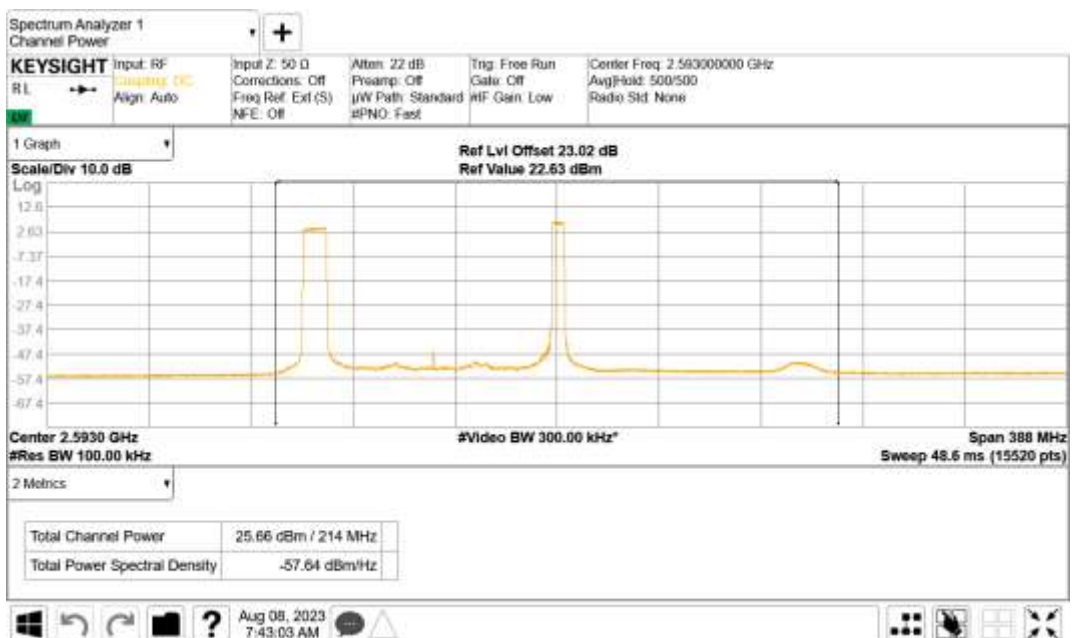



Configuration C

Maximum Output Power 26.00 dBm / Port

Antenna Gain (dBi)	Modulation	Carrier Bandwidth	Output Power	
			Channel Position B	
5.65			Average Power (dBm)	
Antenna Port			dBm	EIRP (dBm)
1A	LTE: QPSK	5+5+5+5+5+5 MHz	25.16	30.81
1B	LTE: QPSK	5+5+5+5+5+5 MHz	25.52	31.17
Total			28.35	34.00
1A	LTE: QPSK	15+15+15+15+15+15 MHz	25.26	30.91
1B	LTE: QPSK	15+15+15+15+15+15 MHz	25.41	31.06
Total			28.35	34.00
1A	NR: QPSK	10+10+10+10+10+10 MHz	25.72	31.37
1B	NR: QPSK	10+10+10+10+10+10 MHz	25.87	31.52
Total			28.81	34.46
1A	NR: QPSK	15+15+15+15+15+15 MHz	25.75	31.40
1B	NR: QPSK	15+15+15+15+15+15 MHz	25.91	31.56
Total			28.84	34.49
1A	NR10+LTE5: QPSK	10+10+10+5+5+5 MHz	25.68	31.33
1B	NR10+LTE5: QPSK	10+10+10+5+5+5 MHz	25.88	31.53
Total			28.79	34.44
1A	* NR10+LTE5: QPSK	10+10+10+5+5+5 MHz	25.16	30.81
1B	* NR10+LTE5: QPSK	10+10+10+5+5+5 MHz	25.31	30.96
Total			28.25	33.90

Antenna Gain (dBi)	Modulation	Carrier Bandwidth	Output Power	
			Channel Position M	
5.65			Average Power (dBm)	
Antenna Port			dBm	EIRP (dBm)
1A	LTE: QPSK	5+5+5+5+5+5 MHz	25.57	31.22
1B	LTE: QPSK	5+5+5+5+5+5 MHz	25.69	31.34
Total			28.64	34.29
1A	LTE: QPSK	15+15+15+15+15+15 MHz	25.27	30.92
1B	LTE: QPSK	15+15+15+15+15+15 MHz	25.49	31.14
Total			28.39	34.04
1A	NR: QPSK	10+10+10+10+10+10 MHz	25.69	31.34
1B	NR: QPSK	10+10+10+10+10+10 MHz	25.91	31.56
Total			28.81	34.46
1A	NR: QPSK	15+15+15+15+15+15 MHz	25.67	31.32
1B	NR: QPSK	15+15+15+15+15+15 MHz	26.13	31.78
Total			28.92	34.57
1A	NR10+LTE5: QPSK	10+10+10+5+5+5 MHz	25.79	31.44
1B	NR10+LTE5: QPSK	10+10+10+5+5+5 MHz	26.16	31.81
Total			28.99	34.64
1A	* NR10+LTE5: QPSK	10+10+10+5+5+5 MHz	-	-
1B	* NR10+LTE5: QPSK	10+10+10+5+5+5 MHz	-	-
Total			-	-



Antenna Gain (dBi)	Modulation	Carrier Bandwidth	Output Power	
			Channel Position T	
Antenna Port			Average Power (dBm)	
			dBm	EIRP (dBm)
5.65				
1A	LTE: QPSK	5+5+5+5+5+5 MHz	25.53	31.18
1B	LTE: QPSK	5+5+5+5+5+5 MHz	25.68	31.33
Total			28.62	34.27
1A	LTE: QPSK	15+15+15+15+15+15 MHz	25.25	30.90
1B	LTE: QPSK	15+15+15+15+15+15 MHz	25.46	31.11
Total			28.37	34.02
1A	NR: QPSK	10+10+10+10+10+10 MHz	25.71	31.36
1B	NR: QPSK	10+10+10+10+10+10 MHz	25.87	31.52
Total			28.80	34.45
1A	NR: QPSK	15+15+15+15+15+15 MHz	25.68	31.33
1B	NR: QPSK	15+15+15+15+15+15 MHz	25.89	31.54
Total			28.80	34.45
1A	NR10+LTE5: QPSK	10+10+10+5+5+5 MHz	26.01	31.66
1B	NR10+LTE5: QPSK	10+10+10+5+5+5 MHz	26.00	31.65
Total			29.02	34.67
1A	* NR10+LTE5: QPSK	10+10+10+5+5+5 MHz	25.30	30.95
1B	* NR10+LTE5: QPSK	10+10+10+5+5+5 MHz	25.44	31.09
Total			28.38	34.03

Remarks

1. The table results are measured at all antenna ports, worst-case performance presented. 2. The plot results represent typical radio performance across all channels. 3. Plot data performance for all transmitter ports and channels are available on request. 4 * indicates a Non-Contiguous (NC) configuration.

Antenna Port B Carrier Power - Modulation LTE: QPSK - Carrier Bandwidth 5+5+5+5+5+5 MHz - Channel Position B



Antenna Port B Carrier Power - Modulation LTE: QPSK - Carrier Bandwidth 15+15+15+15+15+15 MHz - Channel Position B

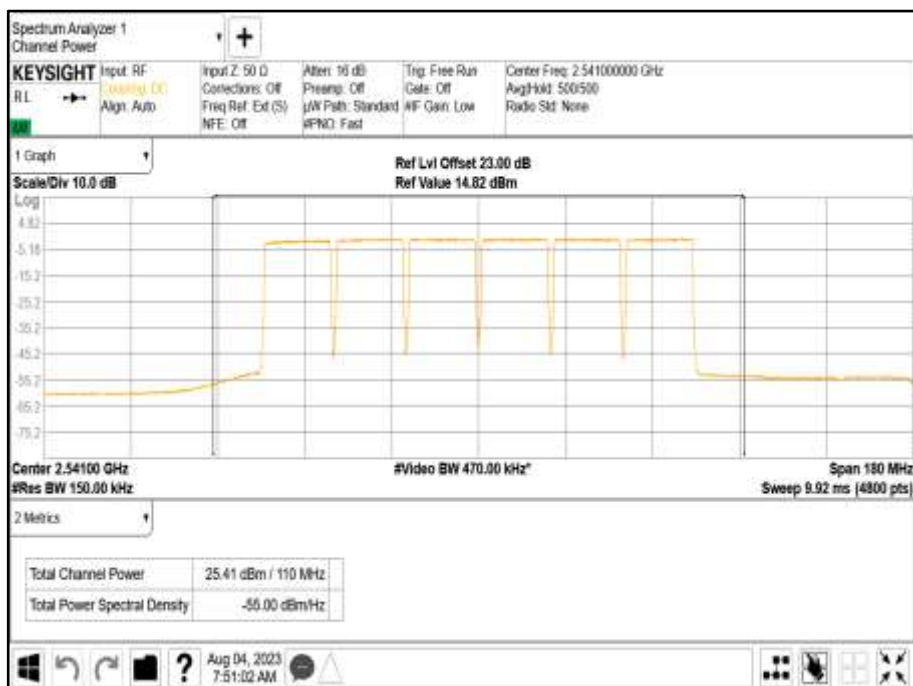

Antenna Port B Carrier Power - Modulation NR: QPSK - Carrier Bandwidth
10+10+10+10+10+10 MHz - Channel Position B

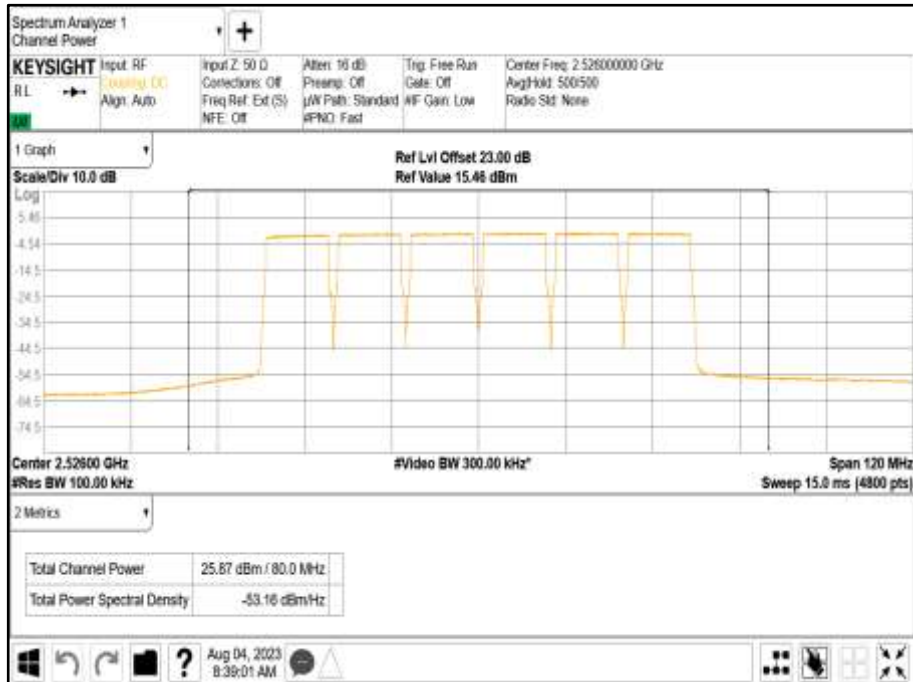

Antenna Port B Carrier Power - Modulation NR: QPSK - Carrier Bandwidth
15+15+15+15+15+15 MHz - Channel Position B

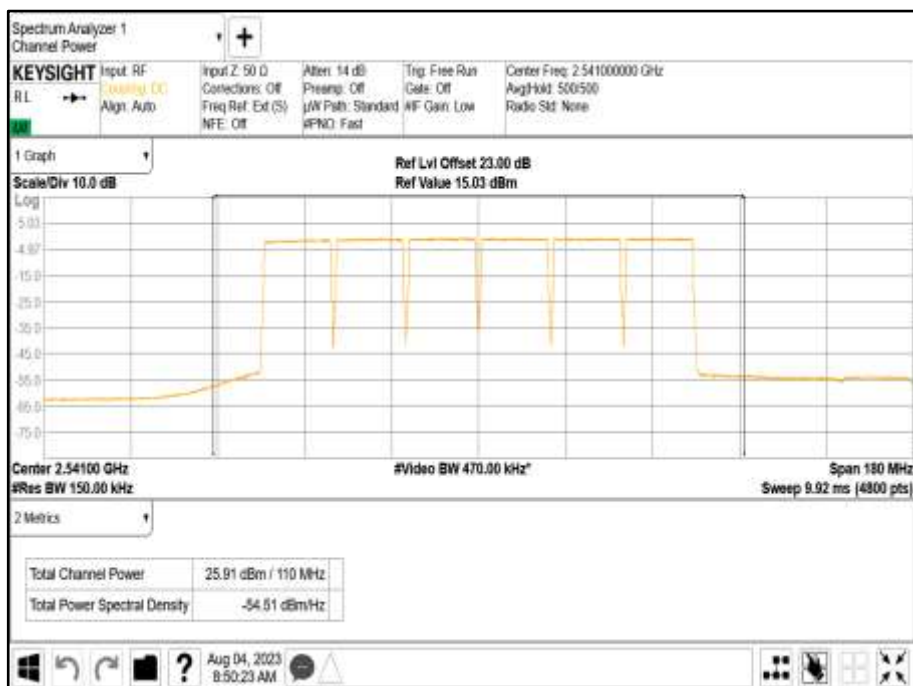

Antenna Port B Carrier Power - Modulation NR10+LTE5: QPSK - Carrier Bandwidth 10+10+10+5+5+5 MHz - Channel Position B

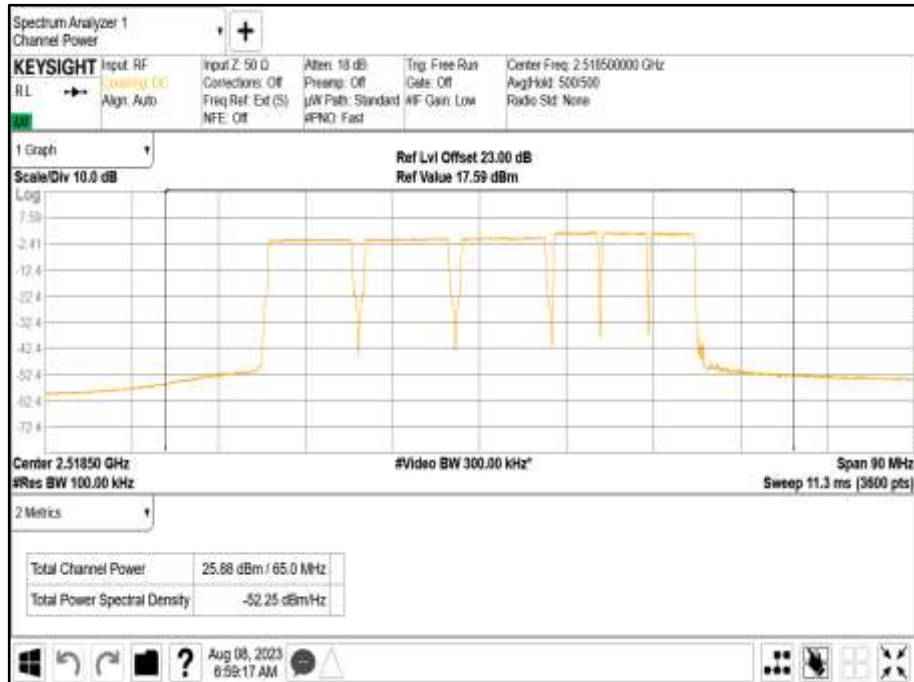

Antenna Port B Carrier Power - Modulation * NR10+LTE5: QPSK - Carrier Bandwidth 10+10+10+5+5+5 MHz - Channel Position B

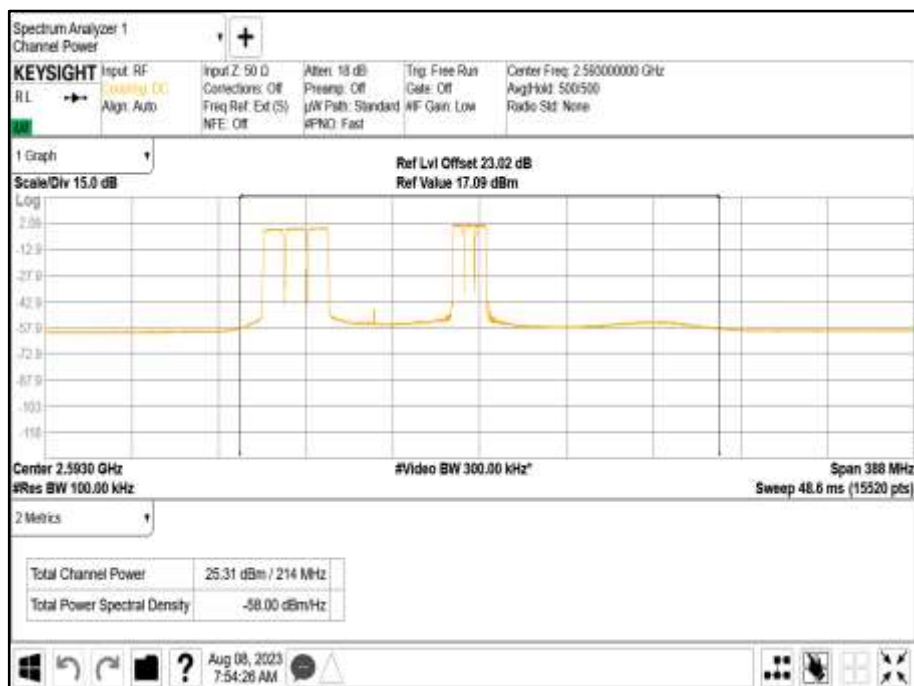



Limit	
Maximum rated output power	$\leq 33 \text{ dBW} + 10\log(X/Y) \text{ dBW}$
Peak to Average Ratio	13 dB



2.2 BAND EDGE

2.2.1 Specification Reference

FCC CFR 47 Part 27, Clause 27.53
FCC CFR 47 Part 2, Clause 2.1051

2.2.2 Date of Test and Modification State

08 and 09-August-2023 - Modification State 0

2.2.3 Test Equipment Used

The major items of test equipment used for the above tests are identified in Section 3.1.

2.2.4 Environmental Conditions

Ambient Temperature	24.7 - 25.0°C
Relative Humidity	31.7 - 33.1%

2.2.5 Test Method

All measurements were made in accordance with FCC KDB 971168 D01, Clause 6.0.

Band Edge measurements were used an Integration Bandwidth of at least 1% of the measured 26dB Bandwidth.

Each antenna port has been declared as being equivalent, therefore measurements were made on one antenna port only. To account for this, the limit was tightened by $10 * \text{Log}(N)$, where N is equal to the number of MIMO antenna ports.

For dual port, the limit was calculated as being $-13 \text{ dBm} - 10 * \text{Log}(2) = -16 \text{ dBm}$.

2.2.6 Test Results



Configuration A

Maximum Output Power 24.00 dBm / Port

Antenna Port A	Modulation	Carrier Bandwidth	Band Edge (MHz)	
			Channel Position B	Channel Position T
A	LTE: QPSK	LTE: 5.0 MHz	2,498.5	2,687.5
A	LTE: QPSK	LTE: 10.0 MHz	2,501.0	2,685.0
A	LTE: QPSK	LTE: 15.0 MHz	2,503.5	2,682.5
A	LTE: QPSK	LTE: 20.0 MHz	2,506.0	2,680.0
A	NR: QPSK	NR: 10.0 MHz	2,501.0	2,685.0
A	NR: QPSK	NR: 15.0 MHz	2,503.5	2,682.5
A	NR: QPSK	NR: 20.0 MHz	2,506.0	2,680.0
A	NR: QPSK	NR: 30.0 MHz	2,511.0	2,675.0
A	NR: QPSK	NR: 40.0 MHz	2,516.0	2,670.0
A	NR: QPSK	NR: 50.0 MHz	2,521.0	2,665.0
A	NR: QPSK	NR: 60.0 MHz	2,526.0	2,660.0
A	NR: QPSK	NR: 70.0 MHz	2,531.0	2,655.0
A	NR: QPSK	NR: 80.0 MHz	2,538.0	2,650.0
A	NR: QPSK	NR: 90.0 MHz	2,541.0	2,645.0
A	NR: QPSK	NR: 100.0 MHz	2,546.0	2,640.0

Remarks

1. Band edge data was captured from the transmit port with maximum measured power.
2. Worst case band edge data presented.

Antenna A - Modulation LTE: QPSK - Carrier Bandwidth LTE: 5.0 MHz - Channel Position B



Antenna A - Modulation LTE: QPSK - Carrier Bandwidth LTE: 5.0 MHz - Channel Position T



Antenna A - Modulation LTE: QPSK - Carrier Bandwidth LTE: 10.0 MHz - Channel Position B

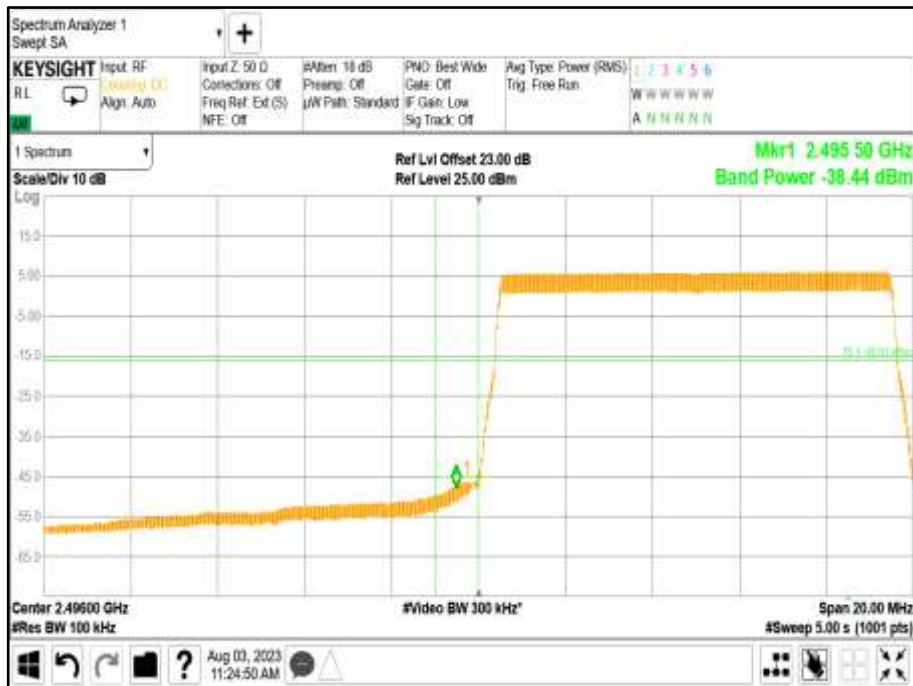

Antenna A - Modulation LTE: QPSK - Carrier Bandwidth LTE: 10.0 MHz - Channel Position T



Antenna A - Modulation LTE: QPSK - Carrier Bandwidth LTE: 15.0 MHz - Channel Position B

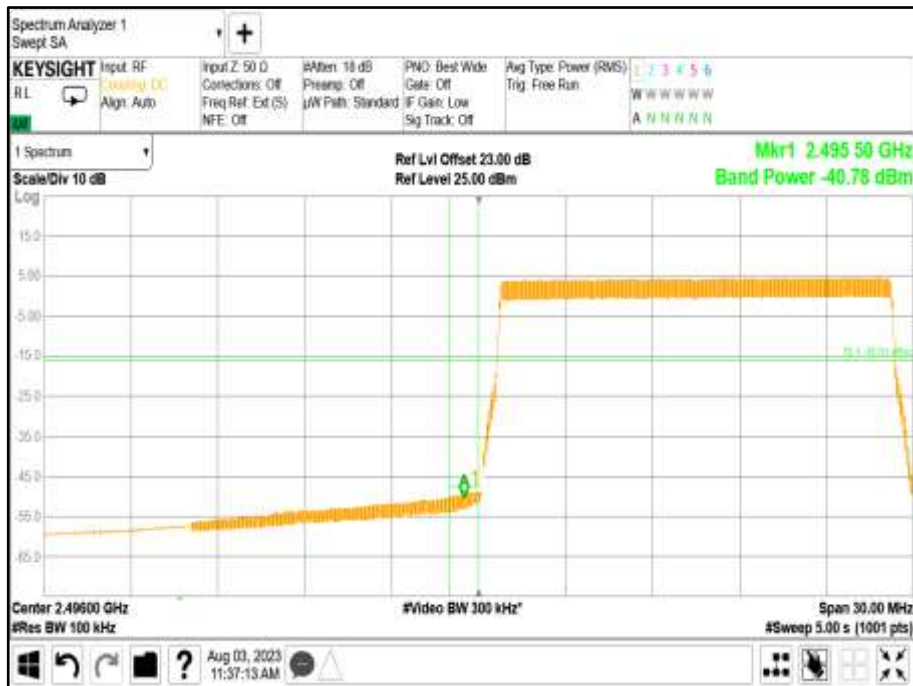

Antenna A - Modulation LTE: QPSK - Carrier Bandwidth LTE: 15.0 MHz - Channel Position T



Antenna A - Modulation LTE: QPSK - Carrier Bandwidth LTE: 20.0 MHz - Channel Position B

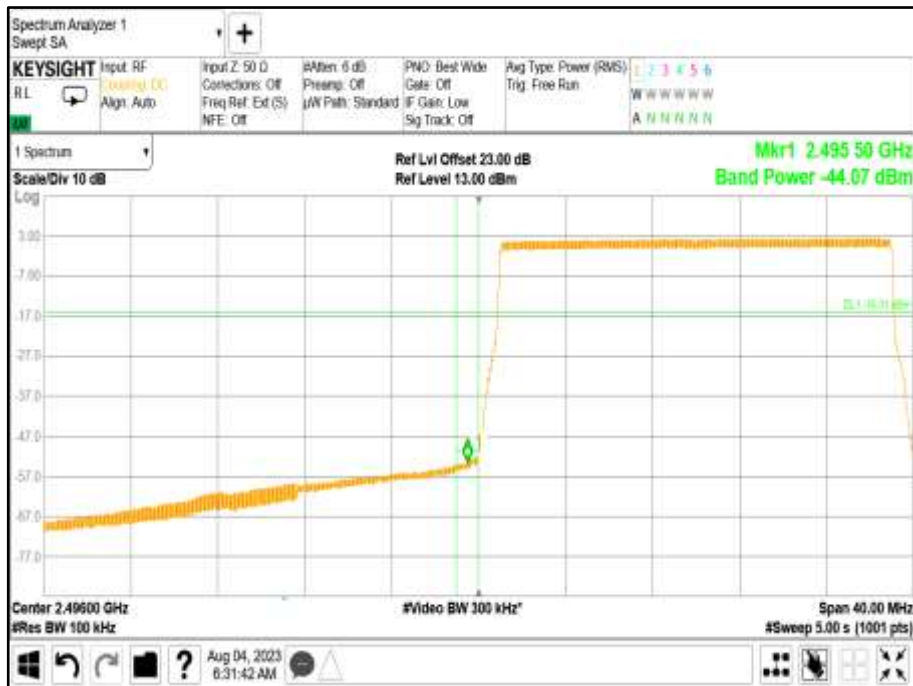

Antenna A - Modulation LTE: QPSK - Carrier Bandwidth LTE: 20.0 MHz - Channel Position T



Antenna A - Modulation NR: QPSK - Carrier Bandwidth NR: 10.0 MHz - Channel Position B

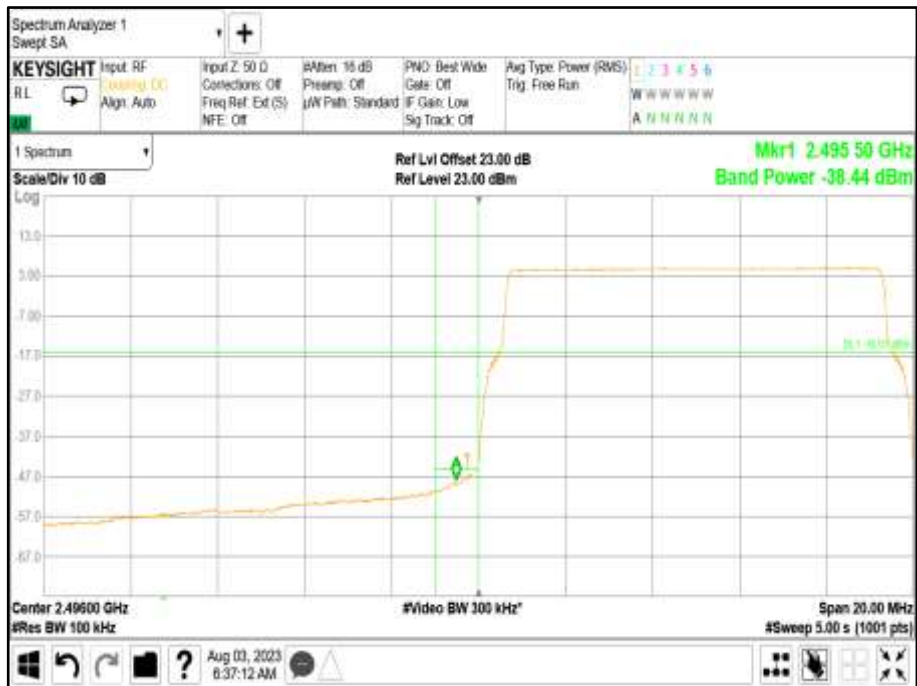

Antenna A - Modulation NR: QPSK - Carrier Bandwidth NR: 10.0 MHz - Channel Position T

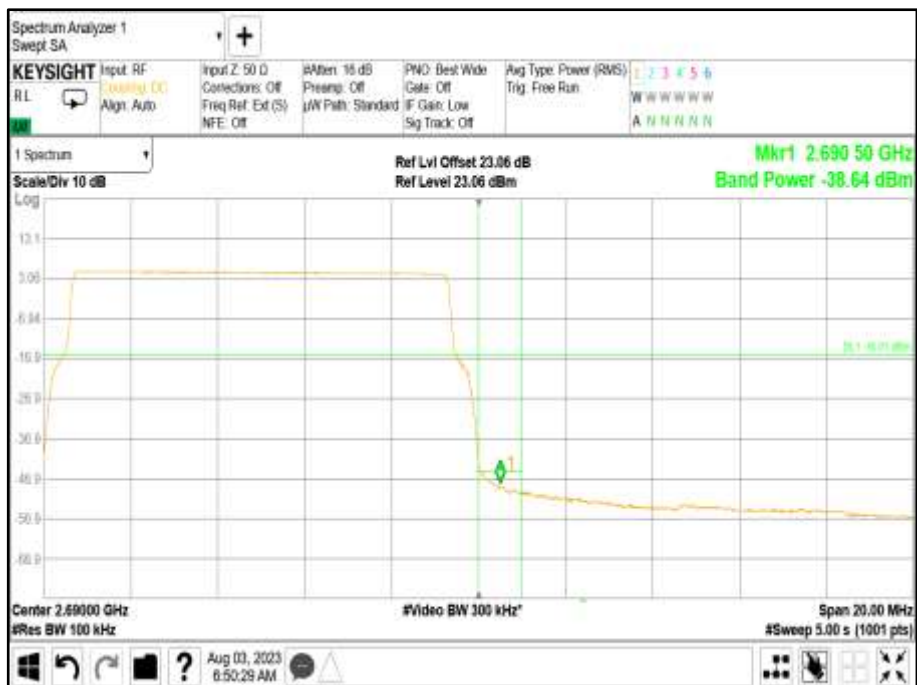

Antenna A - Modulation NR: QPSK - Carrier Bandwidth NR: 15.0 MHz - Channel Position B

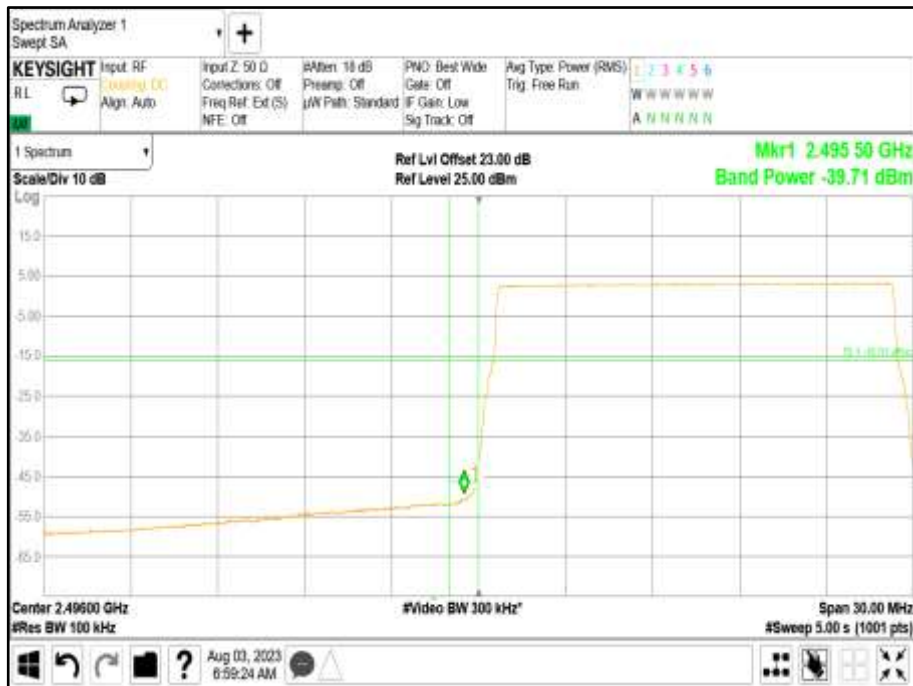

Antenna A - Modulation NR: QPSK - Carrier Bandwidth NR: 15.0 MHz - Channel Position T



Antenna A - Modulation NR: QPSK - Carrier Bandwidth NR: 20.0 MHz - Channel Position B



Antenna A - Modulation NR: QPSK - Carrier Bandwidth NR: 20.0 MHz - Channel Position T



Antenna A - Modulation NR: QPSK - Carrier Bandwidth NR: 30.0 MHz - Channel Position B



Antenna A - Modulation NR: QPSK - Carrier Bandwidth NR: 30.0 MHz - Channel Position T



Antenna A - Modulation NR: QPSK - Carrier Bandwidth NR: 40.0 MHz - Channel Position B



Antenna A - Modulation NR: QPSK - Carrier Bandwidth NR: 40.0 MHz - Channel Position T



Antenna A - Modulation NR: QPSK - Carrier Bandwidth NR: 50.0 MHz - Channel Position B



Antenna A - Modulation NR: QPSK - Carrier Bandwidth NR: 50.0 MHz - Channel Position T



Antenna A - Modulation NR: QPSK - Carrier Bandwidth NR: 60.0 MHz - Channel Position B



Antenna A - Modulation NR: QPSK - Carrier Bandwidth NR: 60.0 MHz - Channel Position T



Antenna A - Modulation NR: QPSK - Carrier Bandwidth NR: 70.0 MHz - Channel Position B

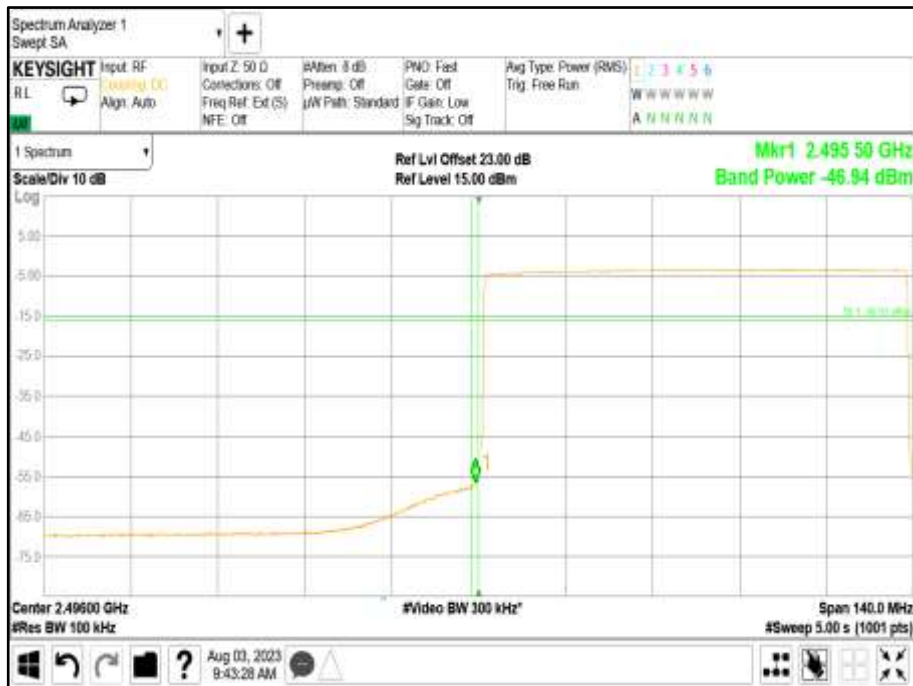

Antenna A - Modulation NR: QPSK - Carrier Bandwidth NR: 70.0 MHz - Channel Position T



Antenna A - Modulation NR: QPSK - Carrier Bandwidth NR: 80.0 MHz - Channel Position B



Antenna A - Modulation NR: QPSK - Carrier Bandwidth NR: 80.0 MHz - Channel Position T



Antenna A - Modulation NR: QPSK - Carrier Bandwidth NR: 90.0 MHz - Channel Position B



Antenna A - Modulation NR: QPSK - Carrier Bandwidth NR: 90.0 MHz - Channel Position T



Antenna A - Modulation NR: QPSK - Carrier Bandwidth NR: 100.0 MHz - Channel Position B



Antenna A - Modulation NR: QPSK - Carrier Bandwidth NR: 100.0 MHz - Channel Position T





Configuration B

Maximum Output Power 26.00 dBm / Port

Antenna	Modulation	Carrier Bandwidth	Band Edge (MHz)	
			Channel Position B	Channel Position T
4A	LTE5: QPSK	L5.0+L5.0 MHz	2498.5+2503.5	2682.5+2687.5
4B	LTE20: QPSK	L20.0+L20.0 MHz	2506+2526.0	2660+2680
4A	NR10: QPSK	NR10+NR10 MHz	2501+2511	2665+2685
4B	NR50: QPSK	NR50+NR50 MHz	2521+2571	2615+2665
4A	NR10+LTE5: QPSK	NR10+L5 MHz	2501+2508.5	2680+2687.5
4B	* NR10+LTE5: QPSK	* NR10+L5 MHz	2,501.0+2593.5	2595+2687.5

Remarks

1. The plots results represent typical radio performance.
2. * indicates a Non-Contiguous (NC) configuration.

Antenna Port A - Modulation LTE5: QPSK - Carrier Bandwidth L5.0+L5.0 MHz - Channel Position B

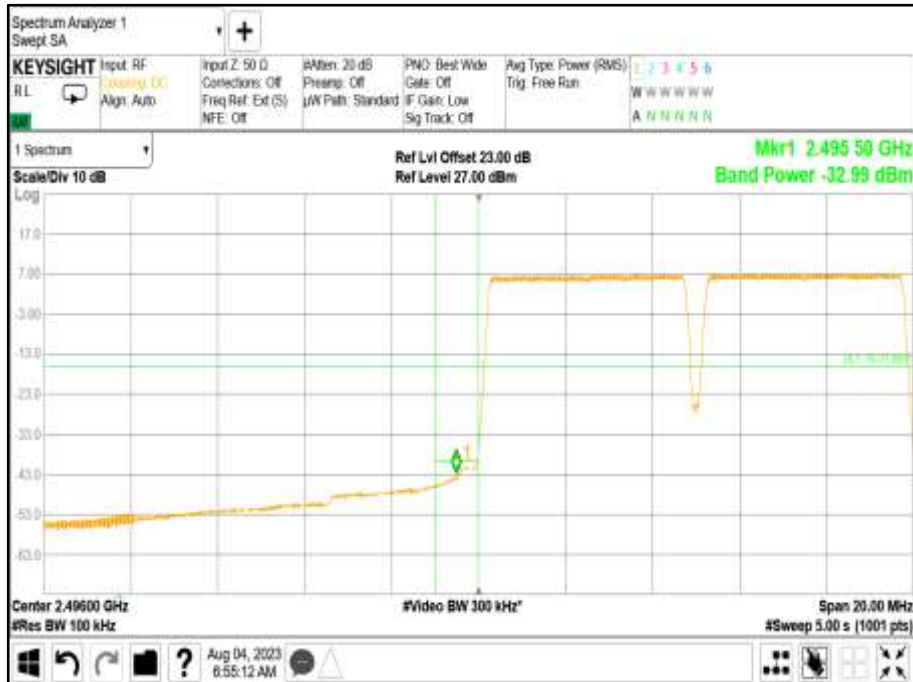

Antenna Port A - Modulation LTE5: QPSK - Carrier Bandwidth L5.0+L5.0 MHz - Channel Position T

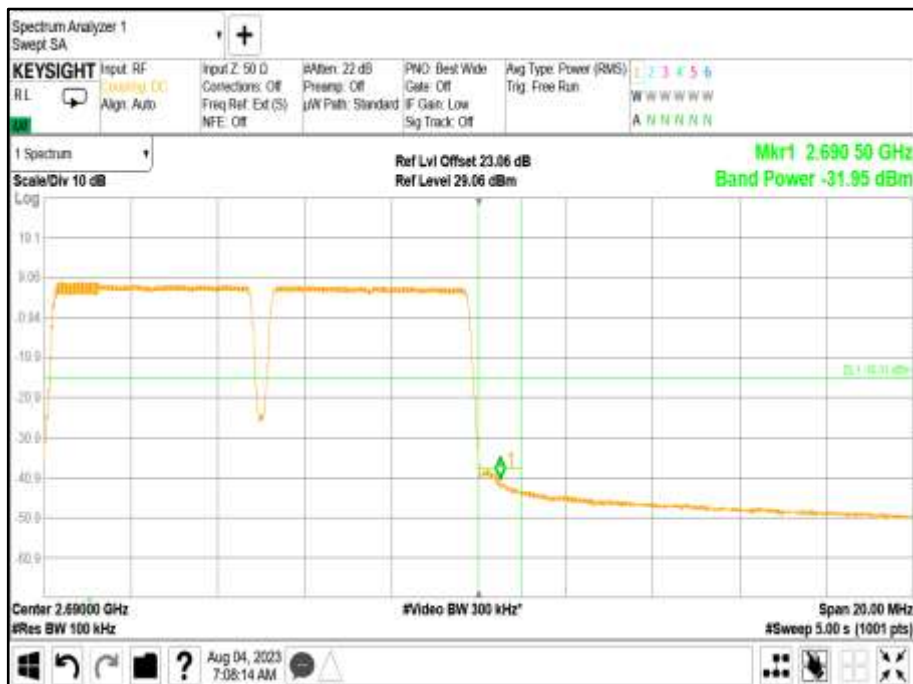

Antenna Port A - Modulation LTE20: QPSK - Carrier Bandwidth L20.0+L20.0 MHz - Channel Position B



Antenna Port A - Modulation LTE20: QPSK - Carrier Bandwidth L20.0+L20.0 MHz - Channel Position T



Antenna Port A - Modulation NR10: QPSK - Carrier Bandwidth NR10+NR10 MHz - Channel Position B

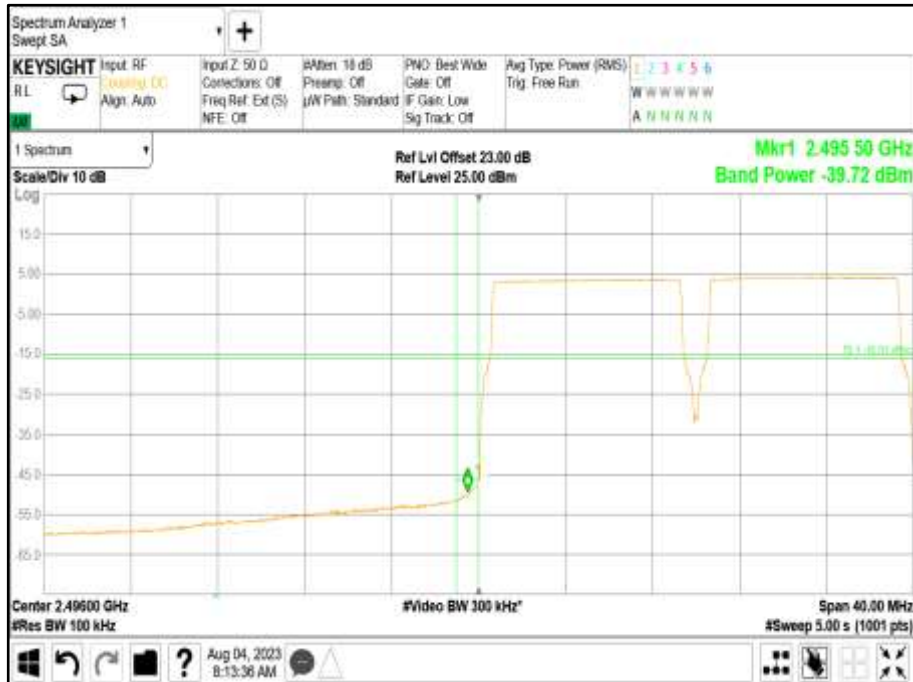

Antenna Port A - Modulation NR10: QPSK - Carrier Bandwidth NR10+NR10 MHz - Channel Position T

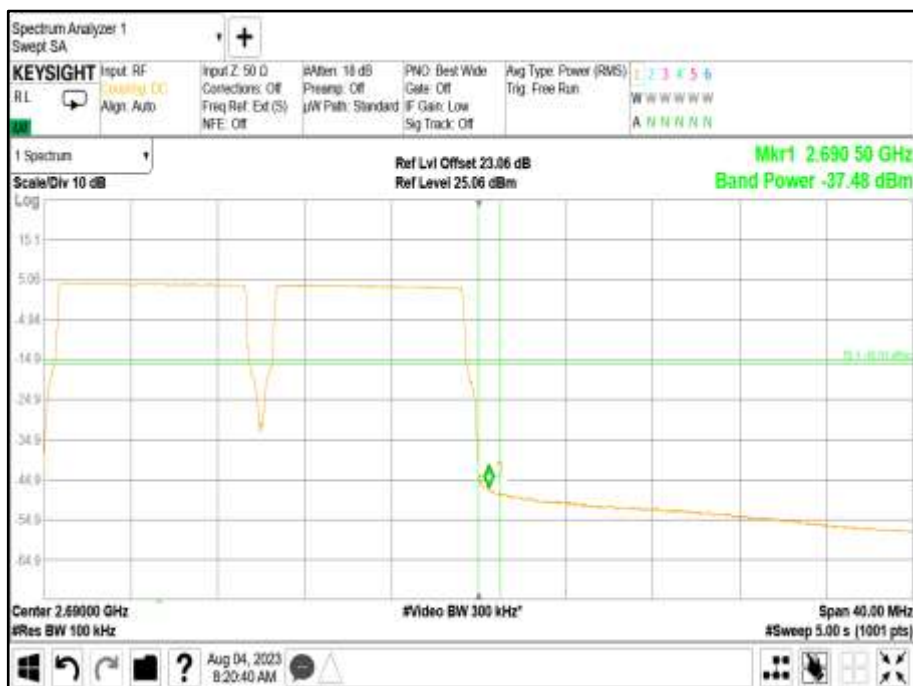

Antenna Port A - Modulation NR50: QPSK - Carrier Bandwidth NR50+NR50 MHz - Channel Position B



Antenna Port A - Modulation NR50: QPSK - Carrier Bandwidth NR50+NR50 MHz - Channel Position T



Antenna Port A - Modulation NR10+LTE5: QPSK - Carrier Bandwidth NR10+L5 MHz - Channel Position B



Antenna Port A - Modulation NR10+LTE5: QPSK - Carrier Bandwidth NR10+L5 MHz - Channel Position T



Antenna Port A - Modulation * NR10+LTE5: QPSK - Carrier Bandwidth * NR10+L5 MHz - Channel Position B

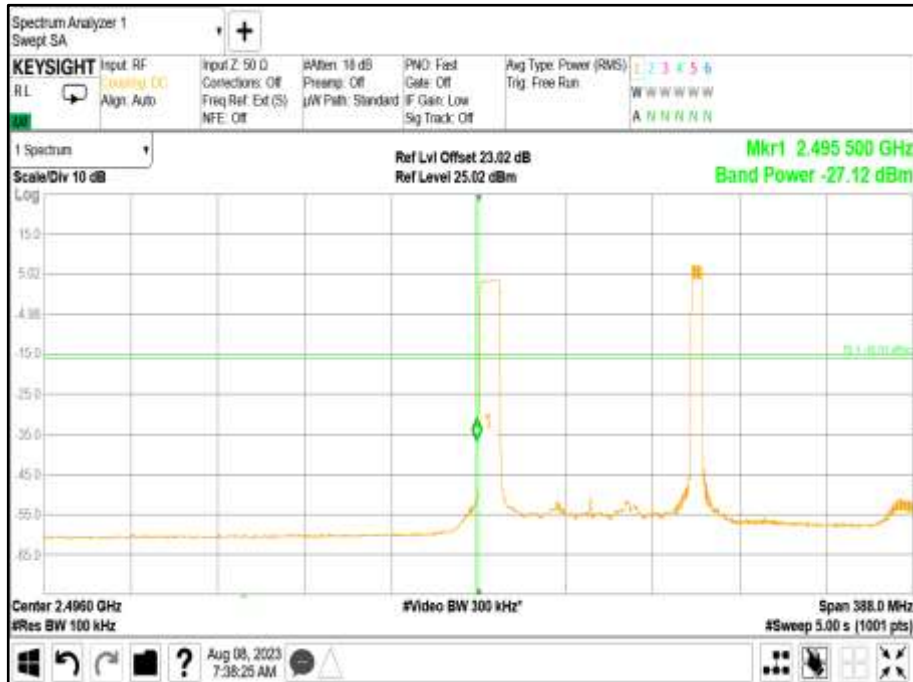

Antenna Port A - Modulation * NR10+LTE5: QPSK - Carrier Bandwidth * NR10+L5 MHz - Channel Position T

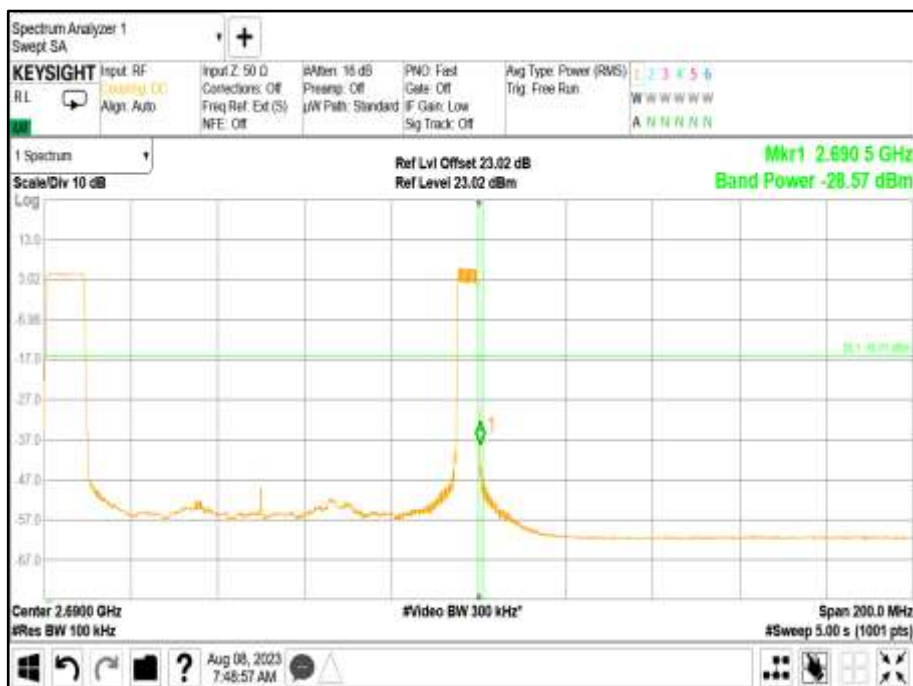



Configuration C

Maximum Output Power 26.00 dBm / Port

Antenna	Modulation	Carrier Bandwidth	Band Edge (MHz)	
			Channel Position B	Channel Position T
A	LTE: QPSK	5+5+5+5+5+5 MHz	2498.5+2503.5+2508.5+2513.5+2518.5+2523.5	2662.5+2667.5+2672.5+2677.5+2682.5+2687.5
A	LTE: QPSK	15+15+15+15+15+15 MHz	2503.5+2518.5+2533.5+2548.5+2563.5+2578.5	2607.5+2622.5+2637.5+2652.5+2667.5+2682.5
A	NR: QPSK	10+10+10+10+10+10 MHz	2501+2511+2521+2531+2541+2551	2635+2645+2655+2665+2675+2685
A	NR: QPSK	15+15+15+15+15+15 MHz	2503.5+2518.5+2533.5+2548.5+2563.5+2578.5	2607.5+2622.5+2637.5+2652.5+2667.5+2682.5
A	NR10+LTE5: QPSK	10+10+10+5+5+5 MHz	2501+2511+2521+2528.5+2533.5+2538.5	2650+2660+2670+2677.5+2682.5+2687.5
A	* NR10+LTE5: QPSK	10+10+10+5+5+5 MHz	2501+2511+2521+2583.5+2588.5+2593.5	2595+2605+2615+2677.5+2682.5+2687.5

Remarks

1. The plots results represent typical radio performance.
2. * indicates a Non-Contiguous (NC) configuration.

Antenna Port A Plots - Modulation LTE: QPSK - Carrier Bandwidth 5+5+5+5+5+5 MHz - Channel Position B

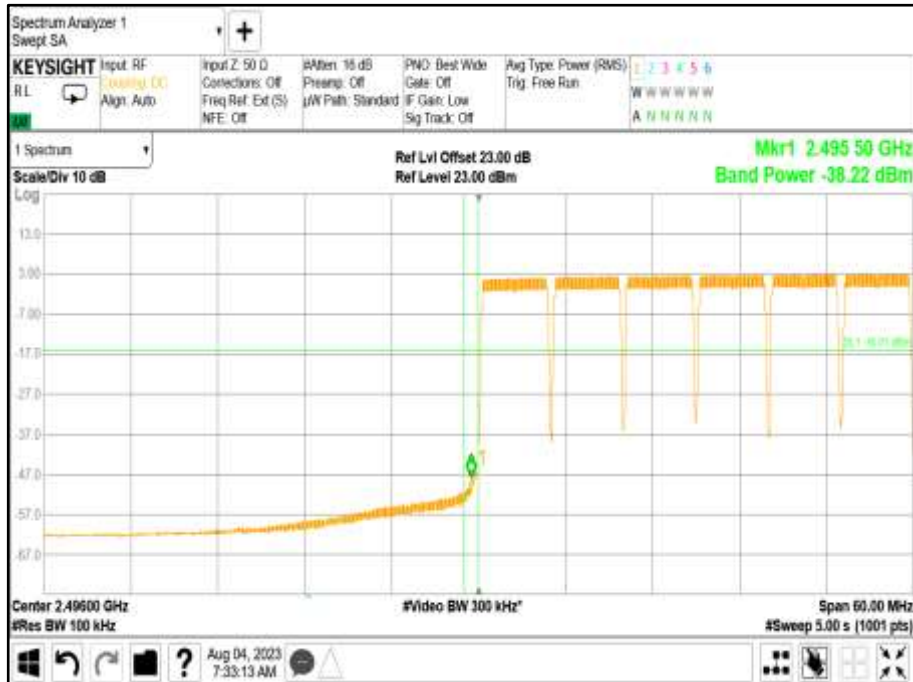

Antenna Port A - Modulation LTE: QPSK - Carrier Bandwidth 5+5+5+5+5+5 MHz - Channel Position T



Antenna Port A - Modulation LTE: QPSK - Carrier Bandwidth 15+15+15+15+15+15 MHz - Channel Position B



Antenna Port A - Modulation LTE: QPSK - Carrier Bandwidth 15+15+15+15+15+15 MHz - Channel Position T



Antenna Port A - Modulation NR: QPSK - Carrier Bandwidth 10+10+10+10+10+10 MHz - Channel Position B



Antenna Port A - Modulation NR: QPSK - Carrier Bandwidth 10+10+10+10+10+10 MHz - Channel Position T



Antenna Port A- Modulation NR: QPSK - Carrier Bandwidth 15+15+15+15+15+15 MHz - Channel Position B



Antenna Port A - Modulation NR: QPSK - Carrier Bandwidth 15+15+15+15+15+15 MHz - Channel Position T



Antenna Port A - Modulation NR10+LTE5: QPSK - Carrier Bandwidth 10+10+10+5+5+5 MHz - Channel Position B



Antenna Port A - Modulation NR10+LTE5: QPSK - Carrier Bandwidth 10+10+10+5+5+5 MHz - Channel Position T





Antenna Port A - Modulation * NR10+LTE5: QPSK - Carrier Bandwidth 10+10+10+5+5+5 MHz - Channel Position B

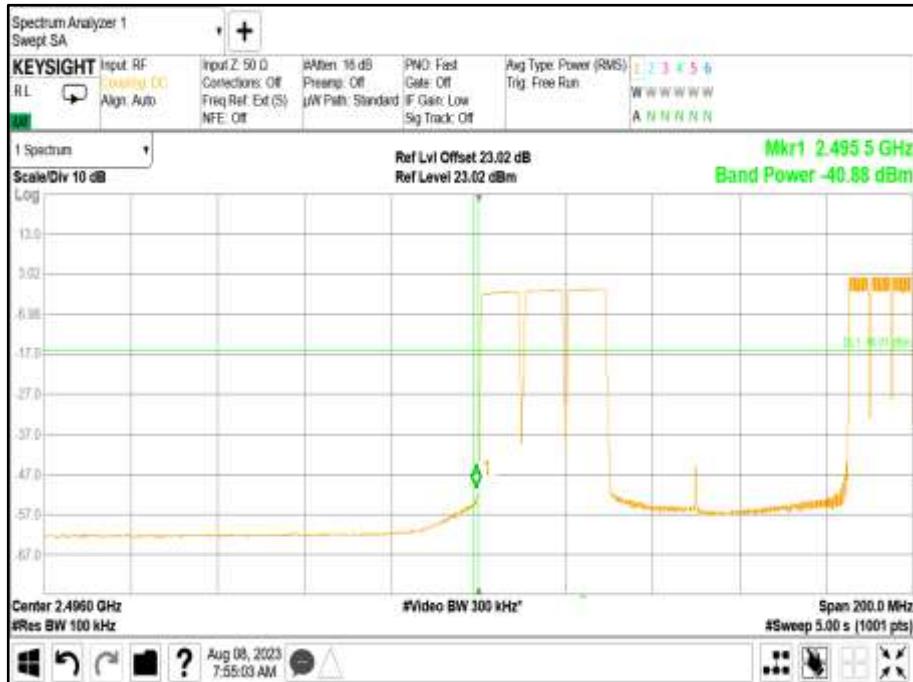

Antenna Port A - Modulation * NR10+LTE5: QPSK - Carrier Bandwidth 10+10+10+5+5+5 MHz - Channel Position T



Limit	-16 dBm
-------	---------



2.3 TRANSMITTER SPURIOUS EMISSIONS

2.3.1 Specification Reference

FCC CFR 47 Part 27, Clause 27.53
FCC CFR 47 Part 2, Clause 2.1051

2.3.2 Date of Test and Modification State

08 and 09-August-2023 - Modification State 0

2.3.3 Test Equipment Used

The major items of test equipment used for the above tests are identified in Section 3.1.

2.3.4 Environmental Conditions

Ambient Temperature	24.7 - 25.0°C
Relative Humidity	31.7 - 33.1%

2.3.5 Test Method

All measurements were made in accordance with FCC KDB 971168 D01, Clause 6.1.

Each antenna port has been declared as being equivalent, therefore measurements were made on one antenna port only. To account for this, the limit was tightened by $10 * \text{Log}(N)$, where N is equal to the number of MIMO antenna ports.

For dual port, the limit was calculated as being $-13 \text{ dBm} - 10 * \text{Log}(2) = -16 \text{ dBm}$.

2.3.6 Test Results

Configuration A

Maximum Output Power 24.00 dBm

Remarks

1. Transceiver spurious emissions have been searched for all channel bandwidths and antenna ports.
2. Representative spurious emissions performance has been presented for all modulations. The smallest Ch BW has been found to result in the worst-case performance.
3. Plot data performance for all channel bandwidths, and channel positions are on file and available on request.



Antenna A - Modulation LTE: QPSK - Carrier Bandwidth 5.0 MHz - Channel Position B - Band 1.00 - Range 0.009 to 4000 MHz

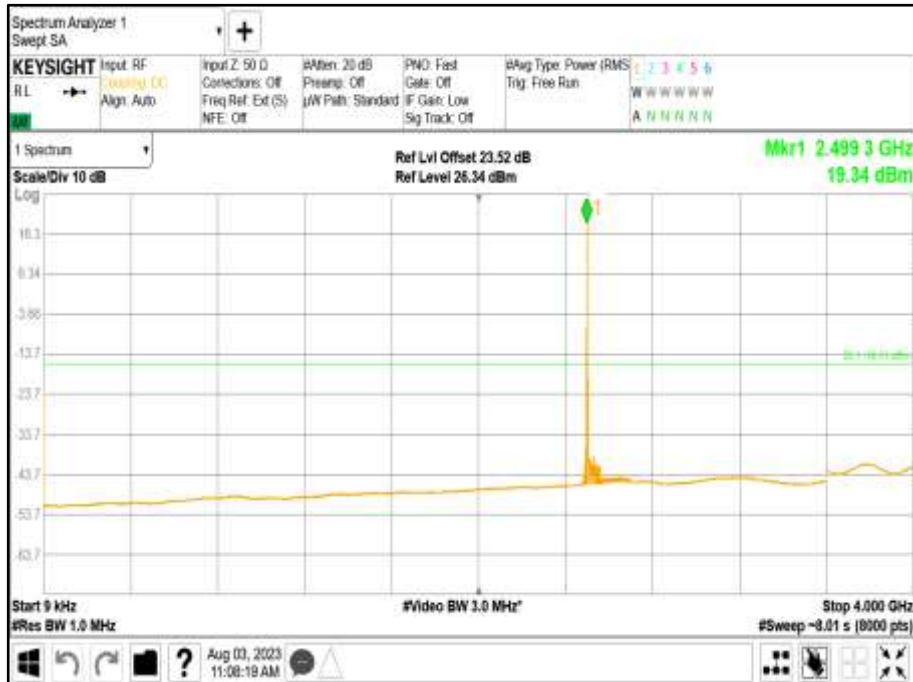

Antenna A - Modulation LTE: QPSK - Carrier Bandwidth 5.0 MHz - Channel Position B - Band 2 - Range 4000 to 12000 MHz

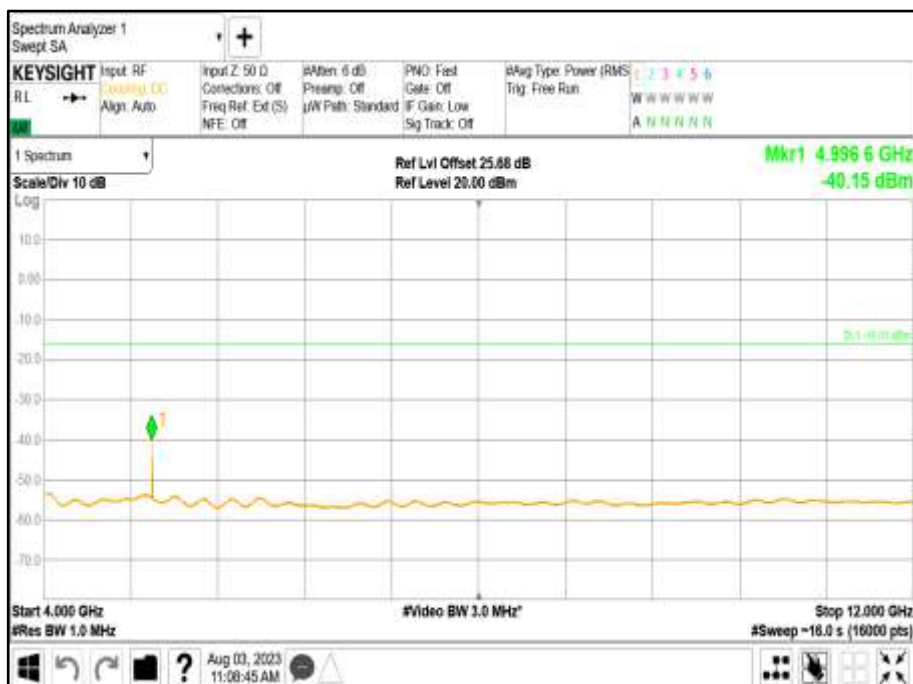

Antenna A - Modulation LTE: QPSK - Carrier Bandwidth 5.0 MHz - Channel Position B - Band 3
- Range 12000 to 26900 MHz

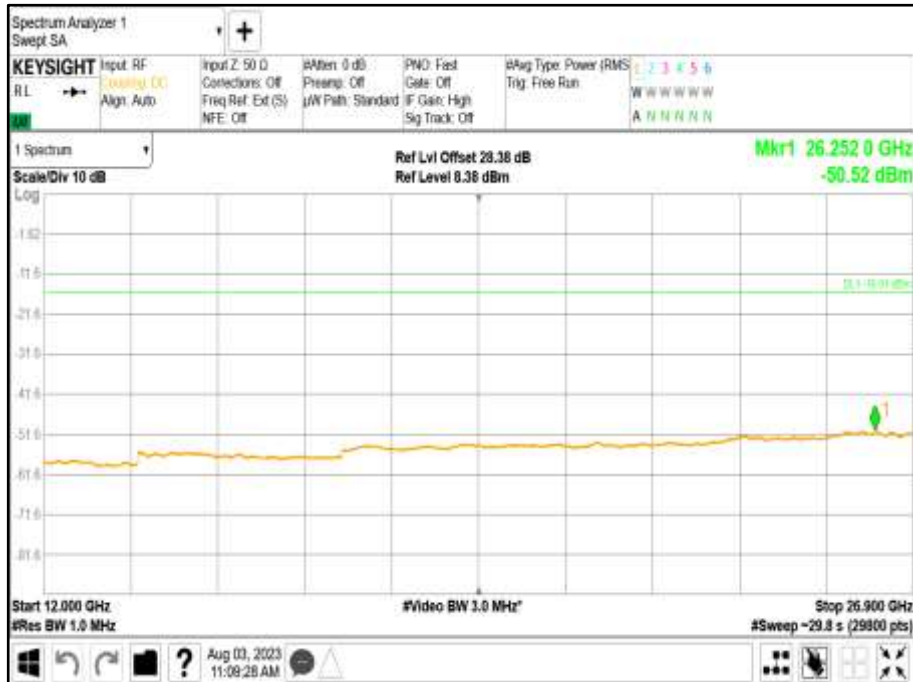

Antenna A - Modulation NR: QPSK - Carrier Bandwidth 20.0 MHz - Channel Position B - Band 1.00
- Range 0.009 to 4000 MHz

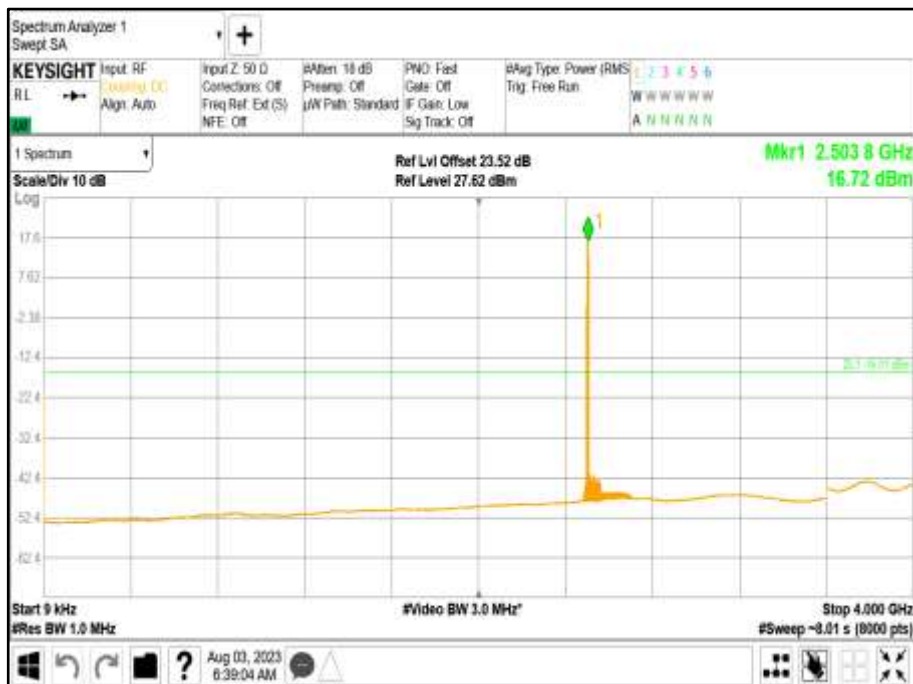



Antenna A - Modulation NR: QPSK - Carrier Bandwidth 20.0 MHz - Channel Position B - Band 2
- Range 4000 to 12000 MHz

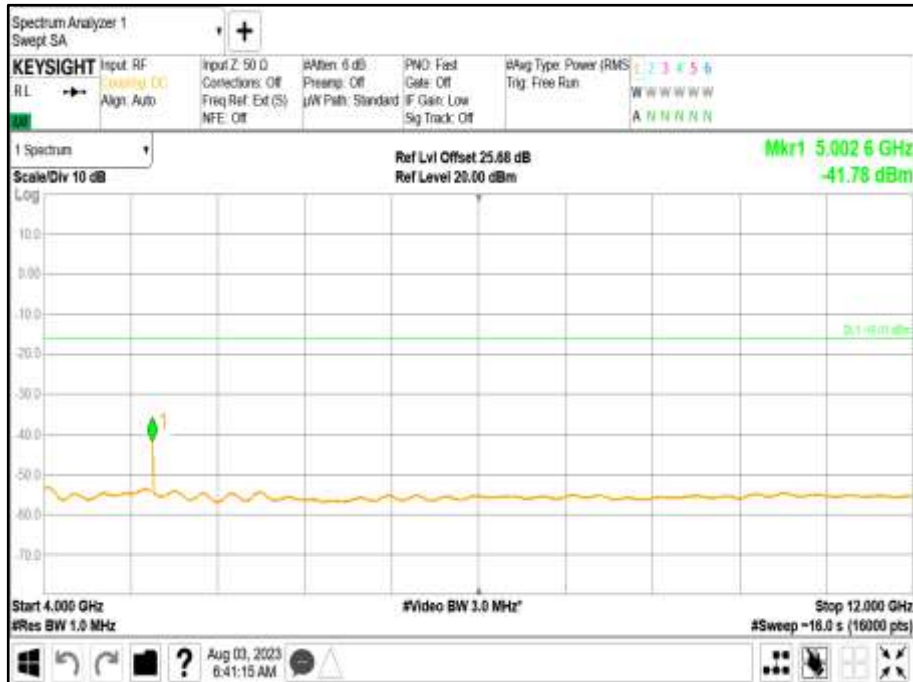

Antenna A - Modulation NR: QPSK - Carrier Bandwidth 20.0 MHz - Channel Position B - Band 3
- Range 12000 to 26900 MHz

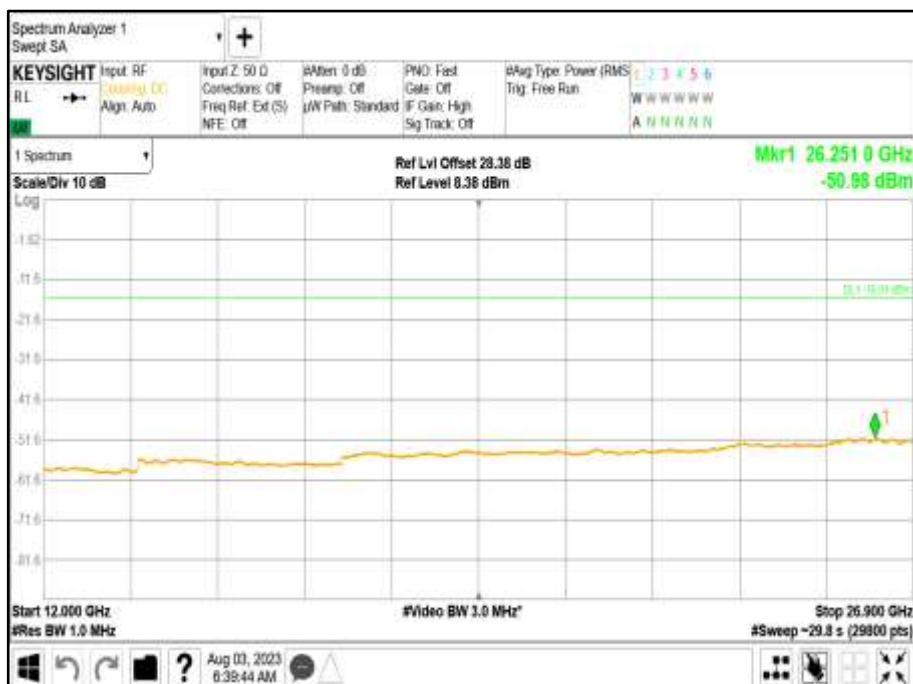



Configuration B

Maximum Output Power 26.00 dBm / Port

Remarks

1. Representative worst-case spurious emissions performance has been presented.
2. All channel BW plots are available upon request.



Antenna A - Modulation LTE5: QPSK - Carrier Bandwidth L5.0+L5.0 MHz - Channel Position B - Band 1.00 - Range 0.009 to 4000 MHz

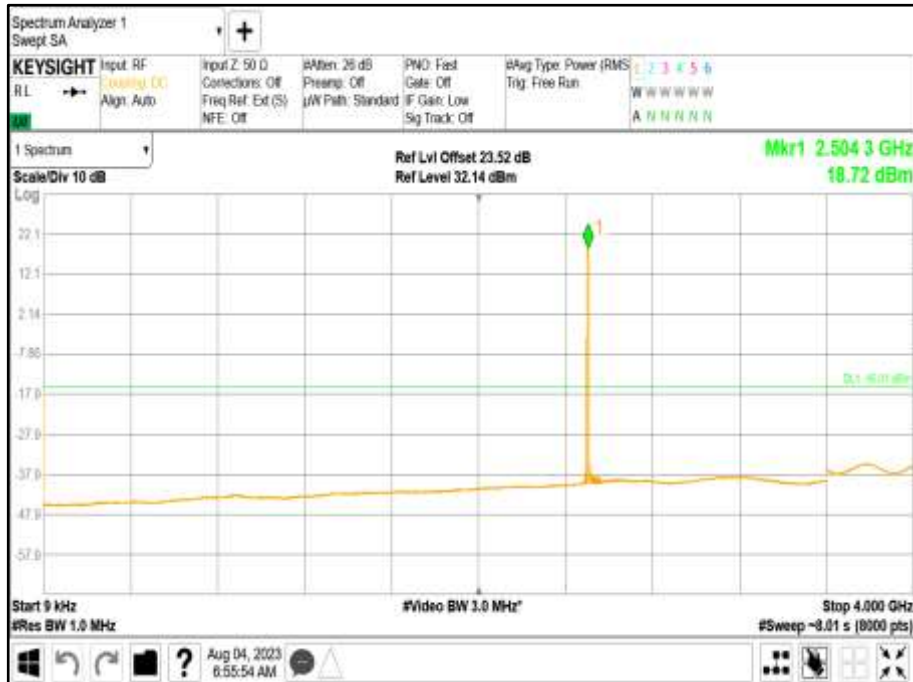

Antenna A - Modulation LTE5: QPSK - Carrier Bandwidth L5.0+L5.0 MHz - Channel Position B - Band 2 - Range 4000 to 12000 MHz



Antenna A - Modulation LTE5: QPSK - Carrier Bandwidth L5.0+L5.0 MHz - Channel Position B - Band 3 - Range 12000 to 26900 MHz



Antenna A - Modulation NR10: QPSK - Carrier Bandwidth NR10+NR10 MHz - Channel Position B - Band 1.00 - Range 0.009 to 4000 MHz

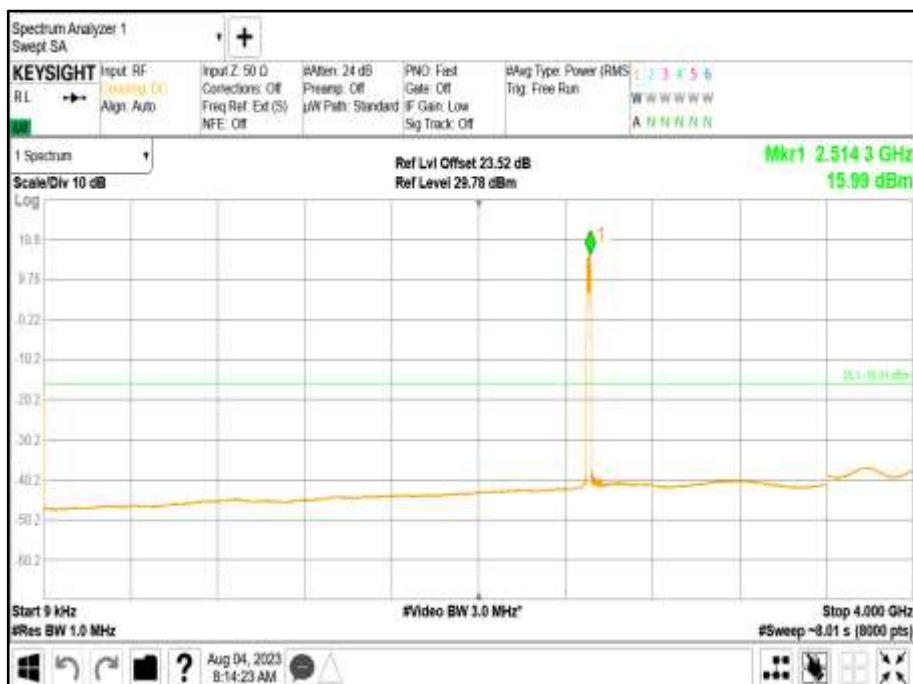



Antenna A - Modulation NR10: QPSK - Carrier Bandwidth NR10+NR10 MHz - Channel Position B - Band 2 - Range 4000 to 12000 MHz

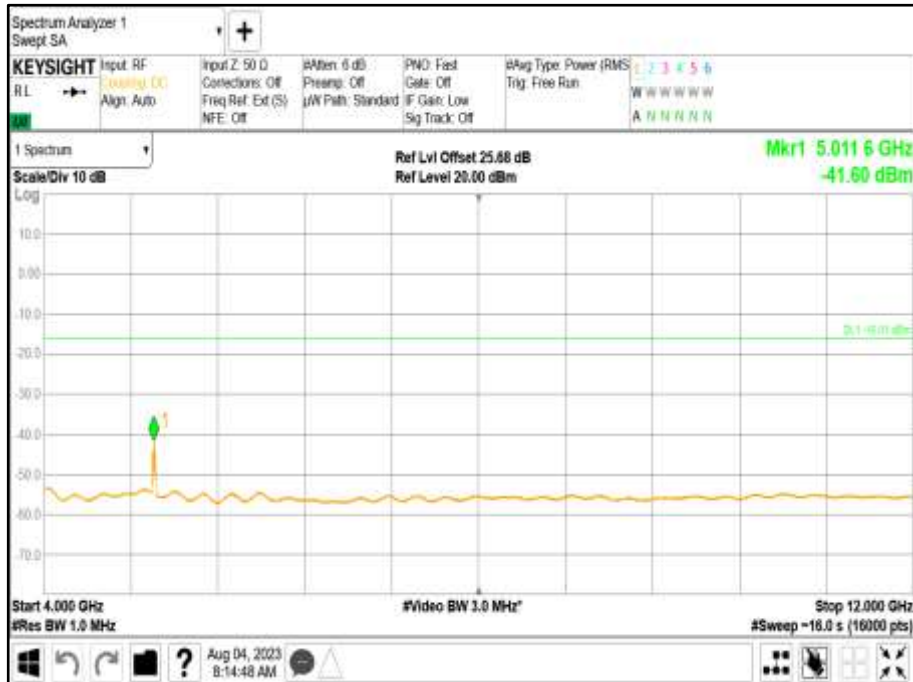

Antenna A - Modulation NR10: QPSK - Carrier Bandwidth NR10+NR10 MHz - Channel Position B - Band 3 - Range 12000 to 26900 MHz





Antenna A - Modulation * NR10+LTE5: QPSK - Carrier Bandwidth * NR10+L5 MHz - Channel Position B - Band 1.00 - Range 0.009 to 4000 MHz

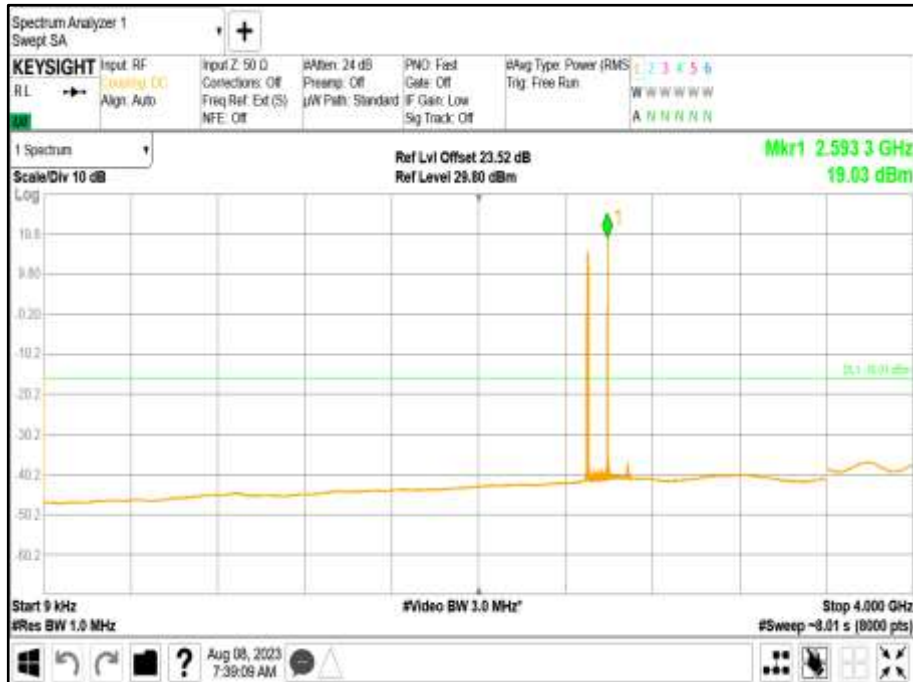

Antenna A - Modulation * NR10+LTE5: QPSK - Carrier Bandwidth * NR10+L5 MHz - Channel Position B - Band 2 - Range 4000 to 12000 MHz

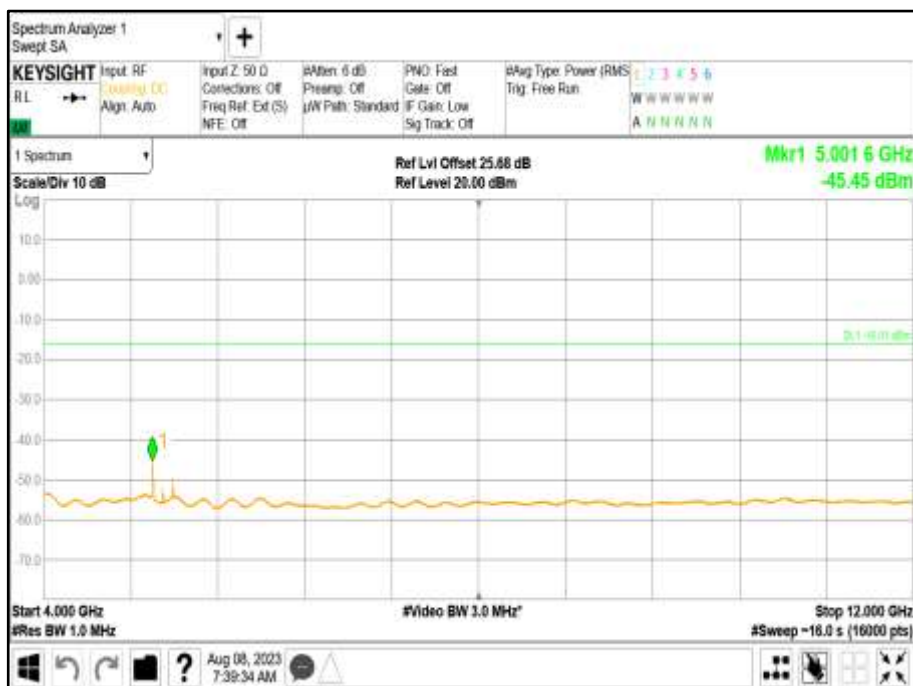



Antenna A - Modulation * NR10+LTE5: QPSK - Carrier Bandwidth * NR10+L5 MHz - Channel Position B - Band 3 - Range 12000 to 26900 MHz

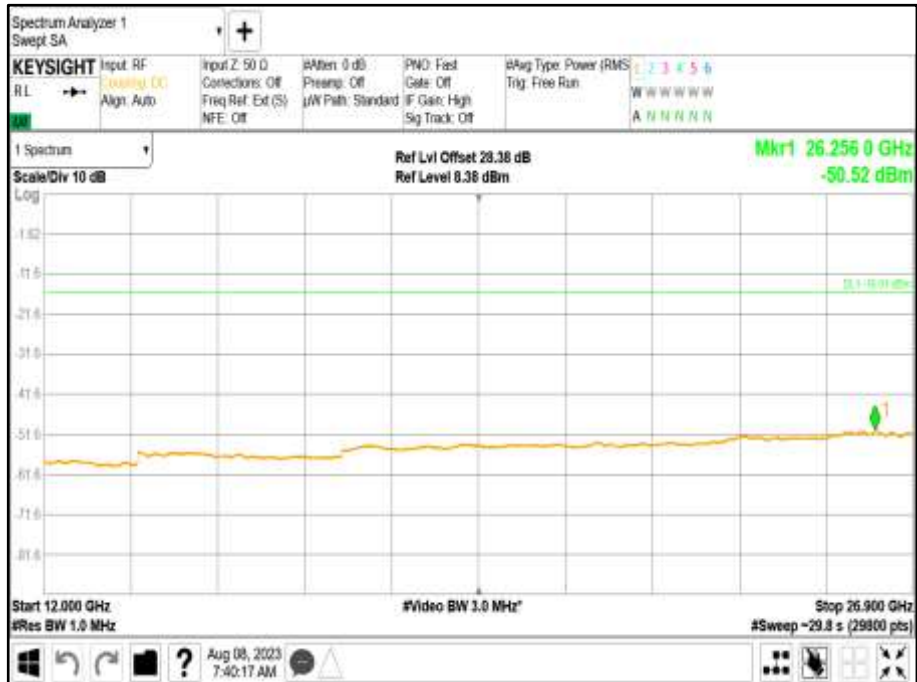



Configuration C

Maximum Output Power 26.00 dBm / Port

Remarks

1. Transceiver spurious emissions have been searched for all channel bandwidths and antenna ports.
2. Representative spurious emissions performance has been presented. The smallest Ch BW has been found to result in the worst-case performance.
3. * represents non-contiguous configuration.
4. Plot data performance for all channel bandwidths, and channel positions are on file and available on request.

Antenna A - Modulation LTE5: QPSK - Carrier Bandwidth 5+5+5+5+5+5 MHz - Channel Position B - Band 1.00 - Range 0.009 to 4000 MHz



Antenna A - Modulation LTE5: QPSK - Carrier Bandwidth 5+5+5+5+5+5 MHz - Channel Position B - Band 2 - Range 4000 to 12000 MHz

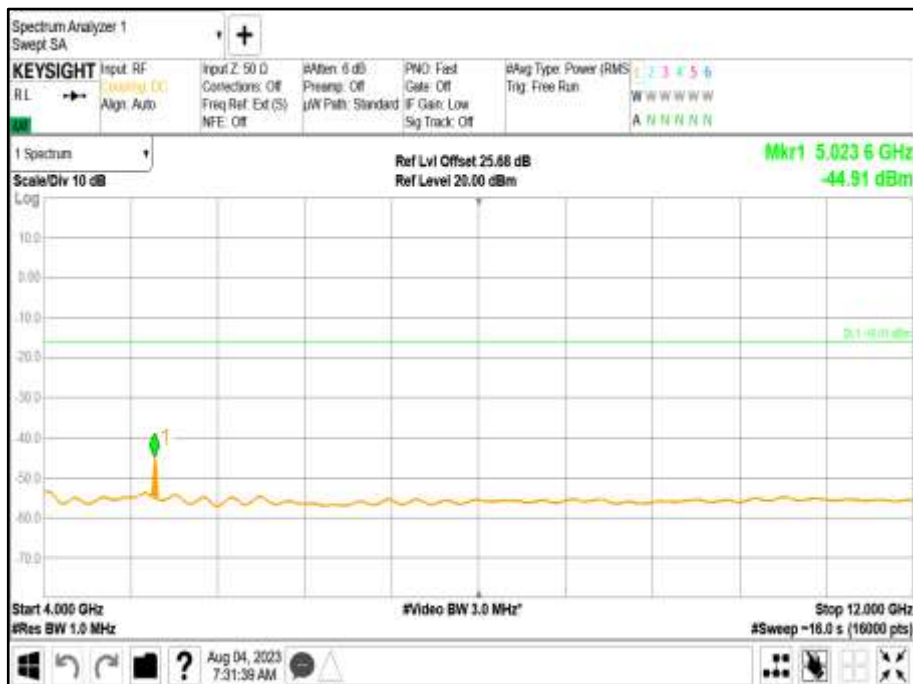

Antenna A - Modulation LTE5: QPSK - Carrier Bandwidth 5+5+5+5+5+5 MHz - Channel Position B - Band 3 - Range 12000 to 26900 MHz



Antenna A - Modulation NR10: QPSK - Carrier Bandwidth 10+10+10+10+10+10 MHz - Channel Position B - Band 1.00 - Range 0.009 to 4000 MHz

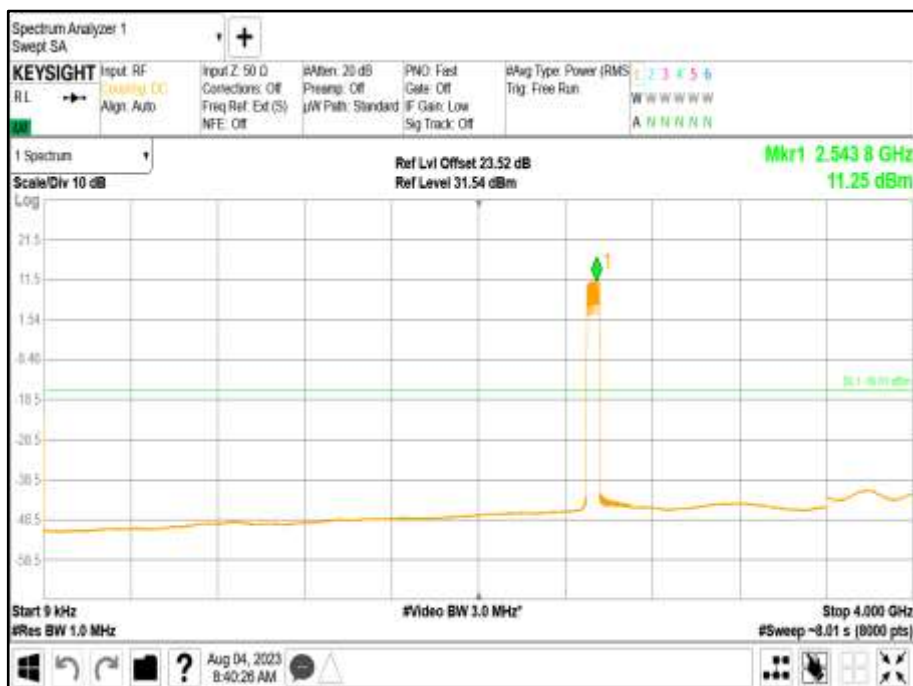



Antenna A - Modulation NR10: QPSK - Carrier Bandwidth 10+10+10+10+10+10 MHz - Channel Position B - Band 2 - Range 4000 to 12000 MHz

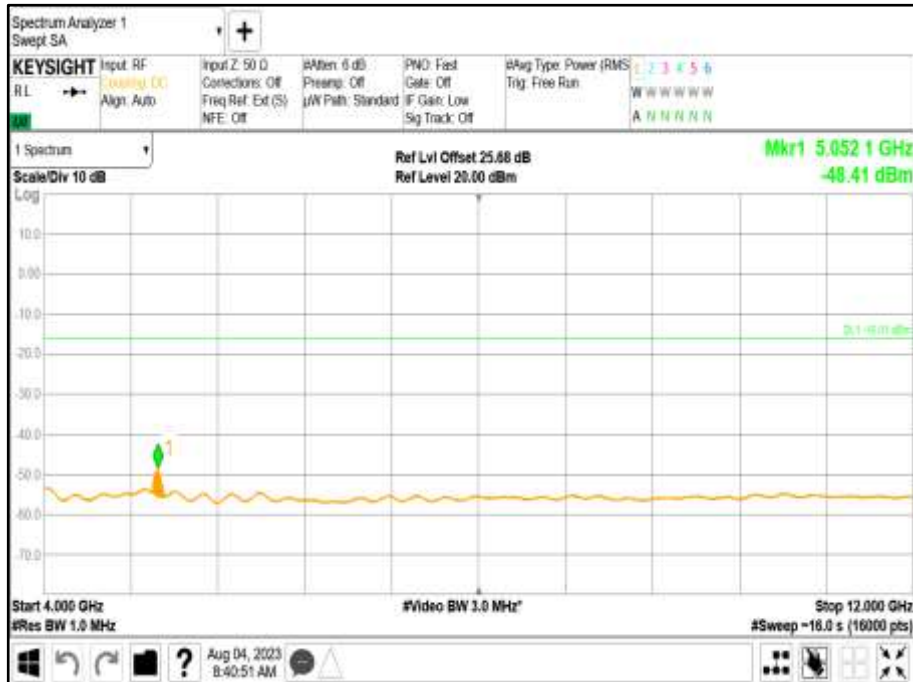

Antenna A - Modulation NR10: QPSK - Carrier Bandwidth 10+10+10+10+10+10 MHz - Channel Position B - Band 3 - Range 12000 to 26900 MHz



Antenna A - Modulation * NR10+LTE5: QPSK - Carrier Bandwidth * 10+10+10+5+5+5 MHz - Channel Position B - Band 1.00 - Range 0.009 to 4000 MHz



Antenna A - Modulation * NR10+LTE5: QPSK - Carrier Bandwidth * 10+10+10+5+5+5 MHz - Channel Position B - Band 2 - Range 4000 to 12000 MHz

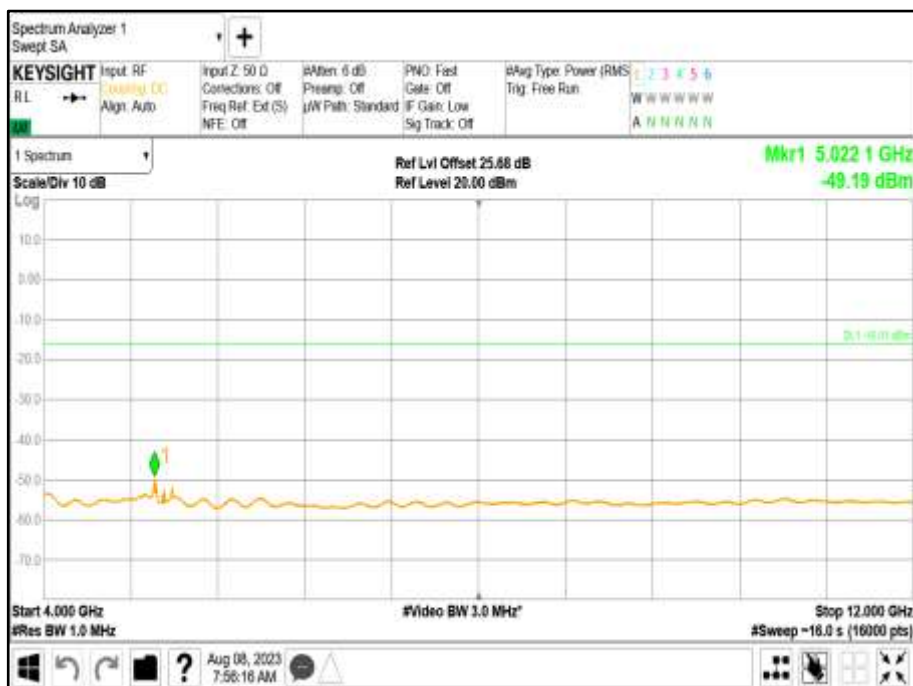



Antenna A - Modulation * NR10+LTE5: QPSK - Carrier Bandwidth * 10+10+10+5+5+5 MHz -
 Channel Position B - Band 3 - Range 12000 to 26900 MHz



Limit	-16dBm
-------	--------



2.4 FREQUENCY STABILITY

2.4.1 Specification Reference

FCC CFR 47 Part 27, Clause 27.54
 FCC CFR 47 Part 2, Clause 2.1055

2.4.2 Date of Test and Modification State

10-August-2023 - Modification State 0

2.4.3 Test Equipment Used

The major items of test equipment used for the above tests are identified in Section 3.1.

2.4.4 Environmental Conditions

Ambient Temperature 24.3°C
 Relative Humidity 30.9%

2.4.5 Test Method

All measurements were made in accordance with FCC KDB 971168 D01, Clause 9 and ANSI C63.26 Clause 5.6

2.4.6 Test Results

Configuration A

Maximum Output Power 24.00 dBm

Temperature	Voltage	B41 Frequency Error (Hz)
		Channel Position B (2 593 000 000 Hz)
-30°C	-48.0 V DC	Transmitter shuts off
-20°C	-48.0 V DC	Transmitter shuts off
-10°C	-48.0 V DC	1.60
0°C	-48.0 V DC	2.34
+10°C	-48.0 V DC	1.97
+20°C	-40.5 V DC	4.75
+20°C	-48.0 V DC	3.40
+20°C	-57.5 V DC	1.69
+30°C	-48.0 V DC	3.69
+40°C	-48.0 V DC	3.52
+50°C	-48.0 V DC	2.67

Remarks

Worst Case deviation or 4.75 Hz = 0.0018312 ppm

Limit	The frequency stability shall be sufficient to ensure that the fundamental emissions stay within the authorized bands of operation.
-------	---



SECTION 3

TEST EQUIPMENT USED



3.1 TEST EQUIPMENT USED

List of absolute measuring and other principal items of test equipment.

Instrument	Manufacturer	Type No.	TE No.	Calibration Period (months)	Calibration Due
Spectrum Analyzer	Keysight	PXA N9030B	MY57144347	12	30-Mar-2024
Thermometer / Refrigeration	Control Company	14-648-233 11705863	230126941	24	22-Feb-2025
PSU	Xantrex	XKW60-50	E00109862	-	O/P Mon
Attenuator (20dB)	Mini-Circuits	BW-K10-2W44+	-	-	O/P Mon
Climate Chamber	Burnsco	RTC-37P-3-3	-07-07	-	O/P Mon

TU – Traceability Unschedule

N/A – Not Applicable

O/P Mon – Output Monitored with Calibrated Equipment



3.2 MEASUREMENT UNCERTAINTY

For a 95% confidence level, the measurement uncertainties for defined systems are:-

Test Discipline	Frequency / Parameter	MU	
Conducted Maximum Peak Output Power	30 MHz to 20 GHz Amplitude	± 0.7 dB	
Conducted Emissions	30 MHz to 20 GHz Amplitude	± 2.1 dB	
Frequency Stability	30 MHz to 2 GHz	± 5.0 Hz	
Occupied Bandwidth	Up to 20 MHz Bandwidth	5 MHz Bandwidth	± 11547 Hz
		10 MHz Bandwidth	± 23094 Hz
		15 MHz Bandwidth	± 34641 Hz
		20 MHz Bandwidth	± 46188 Hz
Band Edge	30 MHz to 20 GHz Amplitude	±0.8 dB	
Radiated Spurious Emissions	30 MHz to 1 GHz	± 5.2 dB	
	1 GHz to 40GHz	± 6.3 dB	

Measurement Uncertainty Decision Rule

Determination of conformity with the specification limits is based on the results of the compliance measurement and does not take into account measurement instrumentation uncertainty as defined in ANSI C63.26:2015 Clause 1.3.

Risk: The uncertainty of measurement about the measured result is negligible with regard to the final pass/fail decision. The measurement result can be directly compared with the test limit to determine conformance with the requirement (compare IEC Guide 115). The level of risk to falsely accept and falsely reject items is further described in ILAC-G8



SECTION 4

ACCREDITATION, DISCLAIMERS AND COPYRIGHT



4.1 ACCREDITATION, DISCLAIMERS AND COPYRIGHT



Certificate # 2955.19

This report relates only to the actual item/items tested.

Our A2LA Accreditation does not cover opinions and interpretations and any expressed are outside the scope of our A2LA Accreditation.

© 2023 TÜV SÜD
TÜV SÜD
TUV SUD Canada, 1280 Teron Rd., Kanata On.

ANNEX A

MODULE LIST

Configuration A/B/C			
Product	Product No	R-State	Serial No
Dot 4465 B77DB77GB41 (EUT)	KRY 901 551/2	R1A	E96A102435
CT11	LPC 102 494/1	R2A	T01G495060
IRU 1648 (for Contig)	KRC 161 842/1	R1D	TD3F105259
IRU 1649 (for Non-contig)	KRC 161 842/2	R1D	TD3F071564
Software Version:	CXP 203 0045/26	Revision:	R17B569