



Add value.
Inspire trust.

Report On

FCC Testing of the
Ericsson NR KRY 901 515/3 (Dot 44Kr B77D) and KRY 901 515/4 (Dot
41Kr B77D), 3700-3980 MHz Base Station in accordance with FCC
CFR 47 Part 2, FCC CFR 47 Part 27

COMMERCIAL-IN-CONFIDENCE

FCC: TA8AKRY901515-3

PREPARED BY

Handwritten signature of Glen Westwell.

Glen Westwell
Test Engineer

APPROVED BY

Handwritten signature of Scott Drysdale.

Scott Drysdale
Authorised Signatory

DATED

26-May-2022

Document 7169011236.1 Report 01 Issue 1

26-May-2022



CONTENTS

Section	Page No
1	REPORT INFORMATION 2
1.1	Report Details 3
1.2	Brief Summary of Results 4
1.3	Test Rationale..... 5
1.4	Configuration Description 6
1.5	Declaration of Build Status 7
1.6	Product Information 8
1.7	Test Setup 9
1.8	Test Conditions..... 11
1.9	Deviation From The Standard 11
1.10	Modification Record 11
1.11	Additional Information 11
2	TEST DETAILS 12
2.1	Maximum Peak Output Power and Peak to Average Ratio - Conducted..... 13
2.2	Occupied Bandwidth..... 29
2.3	Band Edge 33
2.4	Transmitter Spurious Emissions..... 43
2.5	Frequency Stability 54
3	TEST EQUIPMENT USED 56
3.1	Test Equipment Used 57
3.2	Measurement Uncertainty 58
4	ACCREDITATION, DISCLAIMERS AND COPYRIGHT 59
4.1	Accreditation, Disclaimers and Copyright..... 60
ANNEX A	Module Lists.....A.2



SECTION 1

REPORT INFORMATION



1.1 REPORT DETAILS

Manufacturer	Ericsson
Address	Torshamnsgatan 23 Kista SE-16480 Stockholm Sweden
Product Name & Product Number	Dot 41Kr B77D - KRY 901 515/4
Software Version	CXP 203 0045/26 Revision R11AK58
Hardware Version	R1B
Non-Tested Variant	Dot 44Kr B77D - KRY 901 515/3
Test Specification/Issue/Date	FCC CFR 47 Part 2: 2020 FCC CFR 47 Part 27: 2020
Test Plan	DOT 44Kr B77D_RA-FCC_testplan_NR_(TUV SUD)
Start of Test	11-August-2021
Finish of Test	1-February-2022
Name of Engineer(s)	Glen Westwell
Related Document(s)	KDB 971168 D01 v02r02 KDB 662911 D01 v02r01 ICES-003: Issue 7 (2020-10) ANSI C63.26-2015

ENGINEERING STATEMENT

The measurements shown in this report were made in accordance with the procedures described on test pages. All reported testing was carried out on a sample equipment to demonstrate compliance with and FCC CFR 47 Part 2: 2020, FCC CFR 47 Part 27: 2020. The sample tested was found to comply with the requirements defined in the applied rules.

Test Engineer(s);

Glen Westwell



1.2 BRIEF SUMMARY OF RESULTS

A brief summary of results for each configuration, in accordance with FCC CFR 47 Part 2, FCC CFR 47 Part 27 is shown below.

Section	Specification Clause		Test Description	Result
	FCC CFR 47 Part 2	FCC CFR 47 Part 27		
2.1	2.1046	27.50	Maximum Peak Output Power and Peak to Average Ratio - Conducted	Pass
2.2	2.1049	27.53	Occupied Bandwidth	Pass
2.3	2.1051	27.53	Band Edge	Pass
2.4	2.1051	27.53	Transmitter Spurious Emissions	Pass
2.5	2.1055	27.54	Frequency Stability	Pass



1.3 TEST RATIONALE

The tests that have been selected are detailed in the customer Test Plan as defined in section 1.1 of this report. The Test Plan is based on the TÜV SÜD FCC Test Plan Rationale, available on request.



1.4 CONFIGURATION DESCRIPTION

Configuration A					
RAT	NO. of Carriers	Carrier Bandwidth	Carrier Frequency Configuration (MHz)		
			Bottom	Middle	Top
NR	1	20 MHz	3710.0	3840.0	3970.0
		40 MHz	3720.0	3840.0	3960.0
		60 MHz	3730.0	3840.0	3950.0
		80 MHz	3740.0	3840.0	3940.0
		100 MHz	3750.0	3840.0	3930.0

Configuration B					
RAT	No. of Carriers	Carrier Bandwidth	Carrier Frequency Configuration (MHz)		
			Bottom	Middle	Top
NR	2	20+20 MHz	3710.0+3730.0	3830.0+3850.0	3950.0+3970.0
		80+80 MHz	3740.0+3860.0	3800.0+3880.0	3820.0+3940.0

Configuration C					
RAT	No. of Carriers	Carrier BW	Carrier Frequency Configuration (MHz)		
			Bottom	Middle	Top
NR	6	20 MHz	3710+3730+3750+	3790.0+3810.0+3830.0	3870+3890+3910+
			3770+3790+3810	3850.0+3870.0+3890.0	3930+3950+3970

Non-contiguous configurations.

Non-contiguous Configuration B					
RAT	No. of Carriers	Carrier Bandwidth	Carrier Frequency Configuration (MHz)		
			Bottom	Middle	Top
NR	2	20 + 20 MHz	3710.0 + 3890.0	3750.0 + 3930.0	3790.0 + 3970.0
		80 + 80 MHz	3740.0 + 3860.0	3780.0 + 3900.0	3820.0 + 3940.0

Non-contiguous Configuration C					
RAT	No. of Carriers	Carrier Bandwidth	Carrier Frequency Configuration (MHz)		
			Bottom	Middle	Top
NR	6	20 MHz	3710.0+3730.0+3750.0	3750.0+3770.0+3790.0	3790.0+3810.0+3830.0
			+ 3850.0+3870.0+3890.0	+ 3890.0+3910.0+3930.0	+ 3930.0+3950.0+3970.0



1.5 DECLARATION OF BUILD STATUS

MAIN EUT	
MANUFACTURING DESCRIPTION	Radio Dot
MANUFACTURER	Ericsson
TYPE	Remote Radio Base Station
PART NUMBER	KRY 901 515/3 and KRY 901 515/4
SERIAL NUMBER	On file
HARDWARE VERSION	R1B
SOFTWARE VERSION	CXP 203 0045/26 - R11AK58
TRANSMITTER OPERATING RANGE	3700 – 3980 MHz
RECEIVER OPERATING RANGE	3700 – 3980 MHz
COUNTRY OF ORIGIN	China
INTERMEDIATE FREQUENCIES	None
EMISSION DESIGNATOR(S): (i.e. G1D, GXW)	NR: 20M0F9W, 40M0F9W, 60M0F9W, 80M0F9W, 100MF9W
MODULATION TYPES: (i.e. GMSK, QPSK)	NR: QPSK, 16QAM, 64QAM, 256QAM
HIGHEST INTERNALLY GENERATED FREQUENCY	3.98 GHz
OUTPUT POWER (W or dBm)	4 x 0.4W (26dBm)
Antenna gain (dBi)	4.9 dBi
FCC ID	TA8AKRY901515-3 & TA8AKRY901515-4
INDUSTRY CANADA ID	NA
TECHNICAL DESCRIPTION (a brief description of the intended use and operation)	The Dot 44Kr B77D (KRY 901 515/3) and the Dot 41Kr B77D (KRY 901 515/4) are Remote Radio Units forming part of the Ericsson Radio Base Station (RBS) equipment. The Dot provides radio access for mobile and fixed devices and is intended for the indoor environment. The radio operates over 4 Transmit ports in SRO (NR); Single, Multi-Carrier, and MIMO transmission with a maximum rated RF Output of 0.4W per port over an operational temperature of 5°C to +40°C. The unit is designed to be ceiling or wall mounted. The 44Kr and 41Kr radios are identical except that Dot 44Kr has internal antennas and Dot 41Kr has external ports.

Signature:

Denis Lalonde

Date: 18 May 2022

No responsibility will be accepted by TÜV SÜD UK, TÜV SÜD Canada Limited as to the accuracy of the information declared in this document by the manufacturer.

1.6 PRODUCT INFORMATION

1.6.1 Technical Description

The Equipment Under Test (EUT) DOT 41Kr B77D - KRY 901 515/4 is an Ericsson AB Radio Unit working in the public mobile service Band 77D band which provides communication connections to Band 77D network. The EUT operates from a -48V DC supply.

The Equipment Under Test (EUT) is shown in the photograph below. A full technical description can be found in the Manufacturer's documentation.

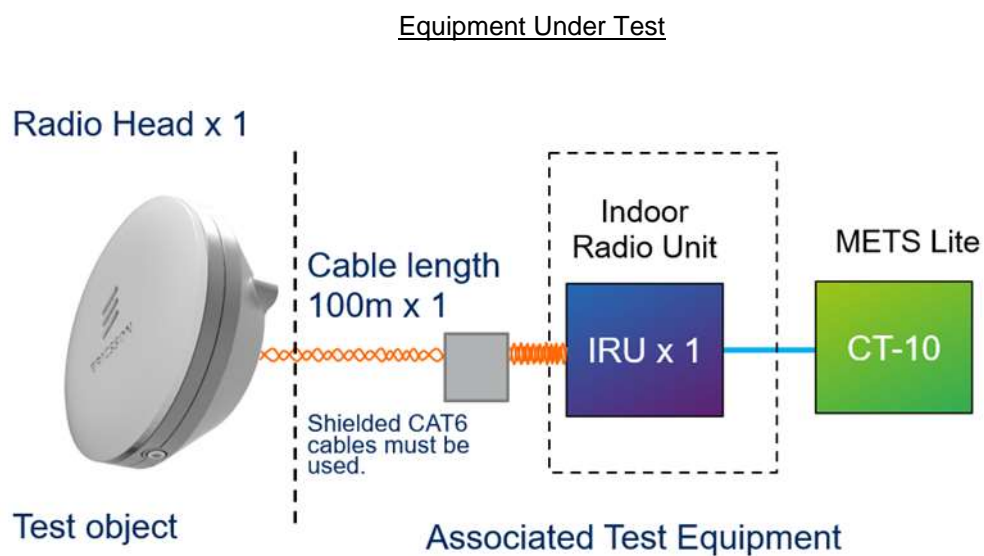

1.7 TEST SETUP

Conducted Test Set Up

Contiguous configuration

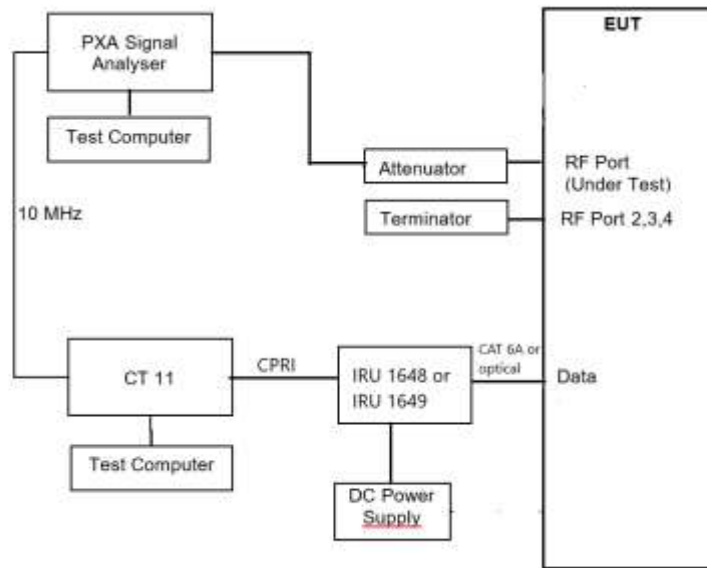

Non-Contiguous configuration

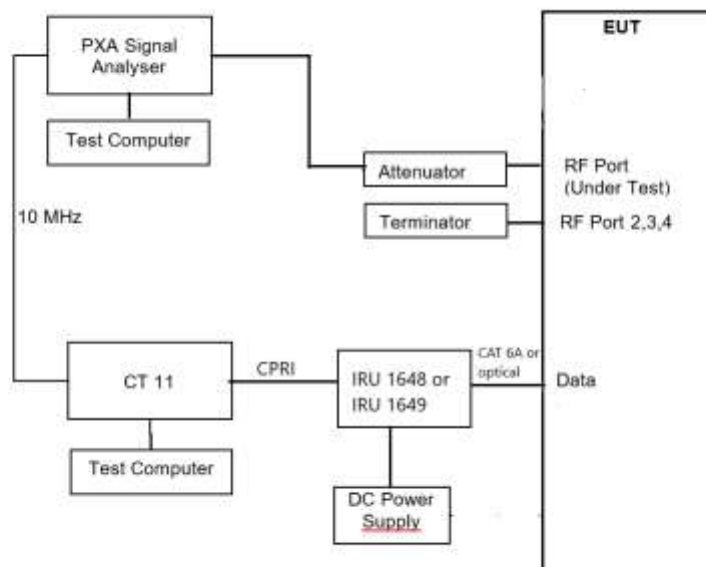



1.8 TEST CONDITIONS

For all tests the EUT was set up in accordance with the relevant test standard and to represent typical operating conditions. Tests were applied with the EUT situated as described in the Test Method for each Test.

The EUT was powered from a -48V DC supply.

FCC Measurement Facility Registration Number
CA4810 TUV SUD Canada, 1280 Teron Rd., Kanata On.

Under our A2LA Accreditation, TÜV SÜD Canada conducted the following tests Ericsson, Ottawa Laboratory: 349 Terry Fox Dr, Kanata, ON.

Test Name	Name of Engineer(s)
Maximum Peak Output Power and Peak to Average Ratio - Conducted	Glen Westwell Steve McFarlane
Occupied Bandwidth	Glen Westwell Steve McFarlane
Band Edge	Glen Westwell Steve McFarlane
Transceiver Spurious Emissions	Glen Westwell Steve McFarlane
Freq. Stab.	Glen Westwell

1.9 DEVIATION FROM THE STANDARD

No deviations from the applicable test standards or test plan were made during testing.

1.10 MODIFICATION RECORD

No modifications were made to the EUT during testing.

1.11 ADDITIONAL INFORMATION

Ericsson will limit this product through the software from operating across the whole of Band 77, it will be limited to Band 77D.

1. This filing is for a Radio Certification for use in the USA under the following ID's:

FCC ID: TA8AKRY901515-3 & TA8AKRY901515-4

2. Transmitter performance was measured for top, mid & bottom channels for contiguous and non-contiguous (NC) operation, where applicable, across all antenna ports as presented in the average power measurement tables. Typical performance is presented and representative of all configuration performance. All configuration data is on file and available upon request.

3. Initial pre-testing was carried out to determine the worst case modulation scheme by measuring the output power from QPSK, 16QAM, 64QAM and 256QAM on the middle channel of one antenna port. From these tests, it was determined that QPSK was equivalent or the worst case modulation scheme and was used for all final testing.



SECTION 2

TEST DETAILS



2.1 MAXIMUM PEAK OUTPUT POWER AND PEAK TO AVERAGE RATIO - CONDUCTED

2.1.1 Specification Reference

FCC CFR 47 Part 27, Clause 27.50
FCC CFR 47 Part 2, Clause 2.1046

2.1.2 Date of Test and Modification State

11-August-2021 - Modification State 0

2.1.3 Test Equipment Used

The major items of test equipment used for the above tests are identified in Section 3.1.

2.1.4 Environmental Conditions

Ambient Temperature	24.6°C
Relative Humidity	30.8%

2.1.5 Test Method

All measurements were made in accordance with FCC KDB 971168 D01, clause 5.2.1 and summed in accordance with FCC KDB 662911 D01.

2.1.6 Test Results



Configuration A

Maximum Output Power 26.00 dBm / Port

Antenna Gain (dBi)	Modulation	Carrier Bandwidth	Peak to Average Ratio (PAR) / Output Power				
			Channel Position B				
Antenna Port			PAR (dB)	Average Power			
	dBm	EIRP (dBm)		dBm/MHz	EIRP dBm/MHz		
4.90							
A	NR: QPSK	20.0 MHz	9.98	25.25	30.15	13.29	18.19
B	NR: QPSK	20.0 MHz	-	24.91	29.81	13.29	18.19
C	NR: QPSK	20.0 MHz	-	25.10	30.00	13.29	18.19
D	NR: QPSK	20.0 MHz	-	25.19	30.09	13.29	18.19
Total			-	31.13	36.03	19.31	24.21
A	NR: QPSK	40.0 MHz	10.31	25.74	30.64	10.86	15.76
B	NR: QPSK	40.0 MHz	-	25.62	30.52	10.86	15.76
C	NR: QPSK	40.0 MHz	-	25.67	30.57	10.86	15.76
D	NR: QPSK	40.0 MHz	-	25.78	30.68	10.86	15.76
Total			-	31.72	36.62	16.88	21.78
A	NR: QPSK	60.0 MHz	10.33	25.98	30.88	9.33	14.23
B	NR: QPSK	60.0 MHz	-	25.92	30.82	9.33	14.23
C	NR: QPSK	60.0 MHz	-	25.88	30.78	9.33	14.23
D	NR: QPSK	60.0 MHz	-	26.18	31.08	9.33	14.23
Total			-	32.01	36.91	15.35	20.25
A	NR: QPSK	80.0 MHz	9.95	26.16	31.06	8.16	13.06
B	NR: QPSK	80.0 MHz	-	25.94	30.84	8.16	13.06
C	NR: QPSK	80.0 MHz	-	26.13	31.03	8.16	13.06
D	NR: QPSK	80.0 MHz	-	26.13	31.03	8.16	13.06
Total			-	32.11	37.01	14.18	19.08
A	NR: QPSK	100.0 MHz	10.69	25.33	30.23	6.48	11.38
B	NR: QPSK	100.0 MHz	-	25.10	30.00	6.48	11.38
C	NR: QPSK	100.0 MHz	-	25.19	30.09	6.48	11.38
D	NR: QPSK	100.0 MHz	-	25.24	30.14	6.48	11.38
Total			-	31.24	36.14	12.50	17.40



Antenna Gain (dBi)	Modulation	Carrier Bandwidth	Peak to Average Ratio (PAR) / Output Power				
			Antenna Port	PAR (dB)	Channel Position M		
Average Power							
4.90				dBm	EIRP (dBm)	dBm/MHz	EIRP dBm/MHz
A	NR: QPSK	20.0 MHz	10.31	25.26	30.16	13.44	18.34
B	NR: QPSK	20.0 MHz	-	25.35	30.25	13.44	18.34
C	NR: QPSK	20.0 MHz	-	25.22	30.12	13.44	18.34
D	NR: QPSK	20.0 MHz	-	25.55	30.45	13.44	18.34
Total			-	31.37	36.27	19.46	24.36
A	NR: QPSK	40.0 MHz	9.68	25.96	30.86	10.93	15.83
B	NR: QPSK	40.0 MHz	-	25.79	30.69	10.93	15.83
C	NR: QPSK	40.0 MHz	-	25.71	30.61	10.93	15.83
D	NR: QPSK	40.0 MHz	-	25.89	30.79	10.93	15.83
Total			-	31.86	36.76	16.95	21.85
A	NR: QPSK	60.0 MHz	9.23	26.05	30.95	9.32	14.22
B	NR: QPSK	60.0 MHz	-	26.02	30.92	9.32	14.22
C	NR: QPSK	60.0 MHz	-	26.13	31.03	9.32	14.22
D	NR: QPSK	60.0 MHz	-	26.29	31.19	9.32	14.22
Total			-	32.14	37.04	15.34	20.24
A	NR: QPSK	80.0 MHz	9.56	26.27	31.17	8.20	13.10
B	NR: QPSK	80.0 MHz	-	26.09	30.99	8.20	13.10
C	NR: QPSK	80.0 MHz	-	26.15	31.05	8.20	13.10
D	NR: QPSK	80.0 MHz	-	26.33	31.23	8.20	13.10
Total			-	32.23	37.13	14.22	19.12
A	NR: QPSK	100.0 MHz	10.28	25.22	30.12	7.02	11.92
B	NR: QPSK	100.0 MHz	-	25.09	29.99	7.02	11.92
C	NR: QPSK	100.0 MHz	-	25.31	30.21	7.02	11.92
D	NR: QPSK	100.0 MHz	-	25.55	30.45	7.02	11.92
Total			-	31.32	36.22	13.04	17.94

Antenna Gain (dBi)	Modulation	Carrier Bandwidth	Peak to Average Ratio (PAR) / Output Power				
			Antenna Port	PAR (dB)	Channel Position T		
Average Power							
4.90				dBm	EIRP (dBm)	dBm/MHz	EIRP dBm/MHz
A	NR: QPSK	20.0 MHz	10.14	25.25	30.15	13.44	18.34
B	NR: QPSK	20.0 MHz	-	24.51	29.41	13.44	18.34
C	NR: QPSK	20.0 MHz	-	24.94	29.84	13.44	18.34
D	NR: QPSK	20.0 MHz	-	24.98	29.88	13.44	18.34
Total			-	30.95	35.85	19.46	24.36
A	NR: QPSK	40.0 MHz	9.15	25.99	30.89	11.18	16.08
B	NR: QPSK	40.0 MHz	-	25.34	30.24	11.18	16.08
C	NR: QPSK	40.0 MHz	-	25.90	30.80	11.18	16.08
D	NR: QPSK	40.0 MHz	-	25.88	30.78	11.18	16.08
Total			-	31.81	36.71	17.20	22.10
A	NR: QPSK	60.0 MHz	9.16	26.19	31.09	9.61	14.51
B	NR: QPSK	60.0 MHz	-	25.90	30.80	9.61	14.51
C	NR: QPSK	60.0 MHz	-	25.94	30.84	9.61	14.51
D	NR: QPSK	60.0 MHz	-	26.38	31.28	9.61	14.51
Total			-	32.13	37.03	15.63	20.53
A	NR: QPSK	80.0 MHz	9.72	26.31	31.21	8.50	13.40
B	NR: QPSK	80.0 MHz	-	25.99	30.89	8.50	13.40
C	NR: QPSK	80.0 MHz	-	26.14	31.04	8.50	13.40
D	NR: QPSK	80.0 MHz	-	26.32	31.22	8.50	13.40
Total			-	32.21	37.11	14.52	19.42
A	NR: QPSK	100.0 MHz	9.99	25.31	30.21	6.75	11.65
B	NR: QPSK	100.0 MHz	-	25.01	29.91	6.75	11.65
C	NR: QPSK	100.0 MHz	-	25.25	30.15	6.75	11.65
D	NR: QPSK	100.0 MHz	-	25.32	30.22	6.75	11.65
Total			-	31.24	36.14	12.77	17.67



Remarks

1. Transmitter performance has been presented for top, mid, bottom channels across all antenna ports as represented in the following tables.
2. Typical performance and measurement plot data has been presented for reference.
3. All contiguous and non-contiguous (NC) plot data is on file and available upon request.



Antenna Port A Carrier Power - Modulation NR: QPSK - Carrier Bandwidth 20.0 MHz - Channel Position B



Antenna Port A Pk-Av Ratio - Modulation NR: QPSK - Carrier Bandwidth 20.0 MHz - Channel Position B

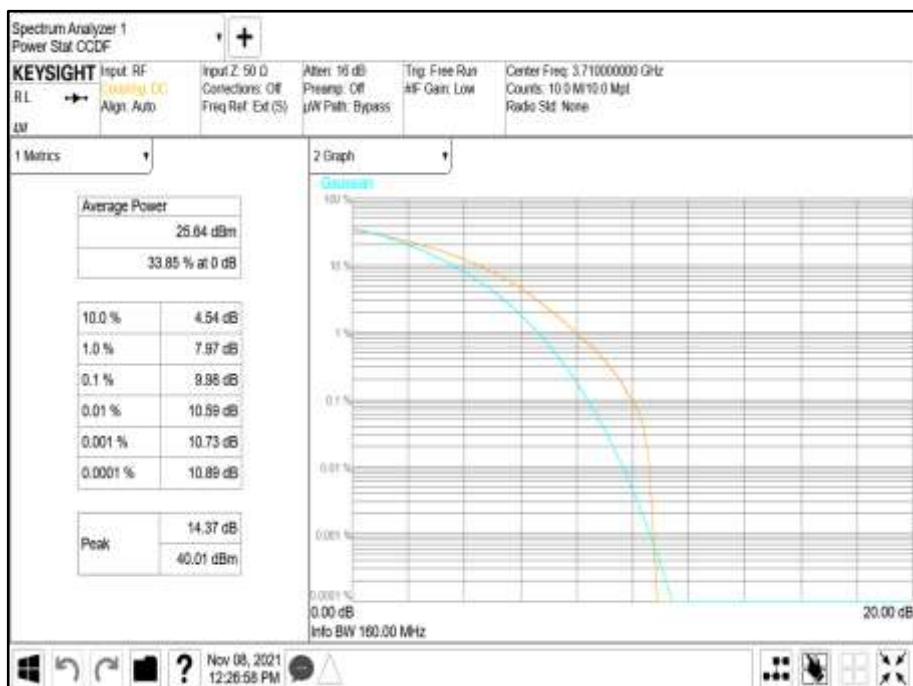



Antenna Port A PSD - Modulation NR: QPSK - Carrier Bandwidth 20.0 MHz - Channel Position B



Antenna Port A Carrier Power - Modulation NR: QPSK - Carrier Bandwidth 40.0 MHz - Channel Position B

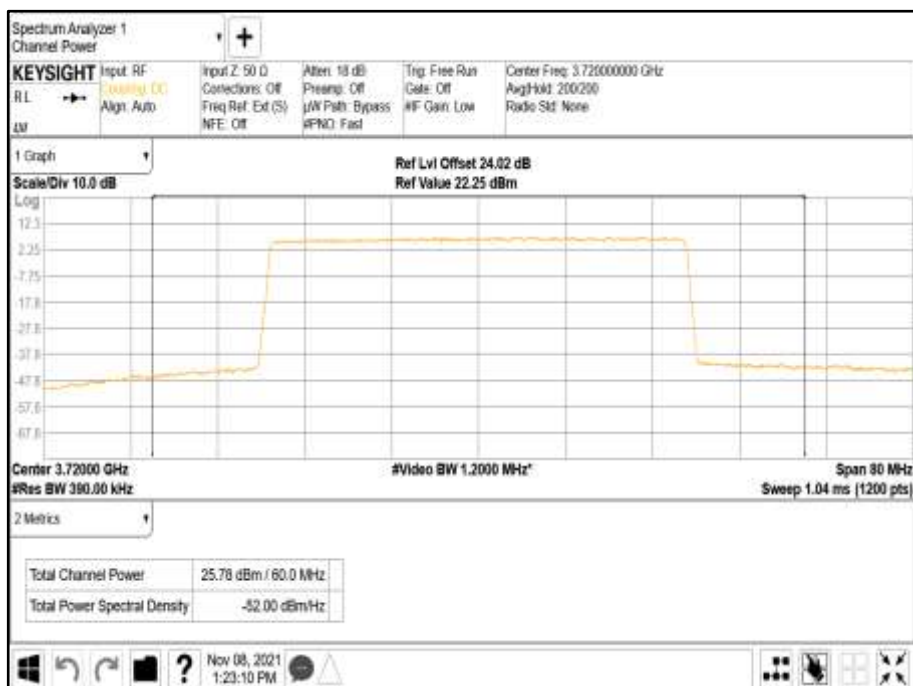



Antenna Port A Pk-Av Ratio - Modulation NR: QPSK - Carrier Bandwidth 40.0 MHz - Channel Position B

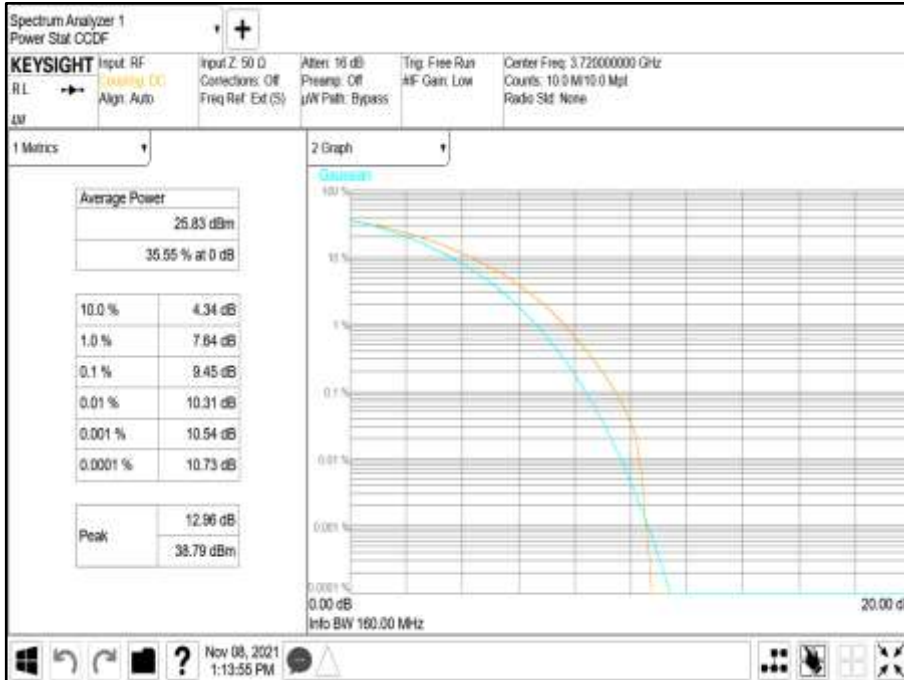

Antenna Port A PSD - Modulation NR: QPSK - Carrier Bandwidth 40.0 MHz - Channel Position B





Antenna Port A PSD - Modulation NR: QPSK - Carrier Bandwidth 60.0 MHz - Channel Position B



Antenna Port A Carrier Power - Modulation NR: QPSK - Carrier Bandwidth 80.0 MHz - Channel Position B





Antenna Port A Pk-Av Ratio - Modulation NR: QPSK - Carrier Bandwidth 80.0 MHz - Channel Position B

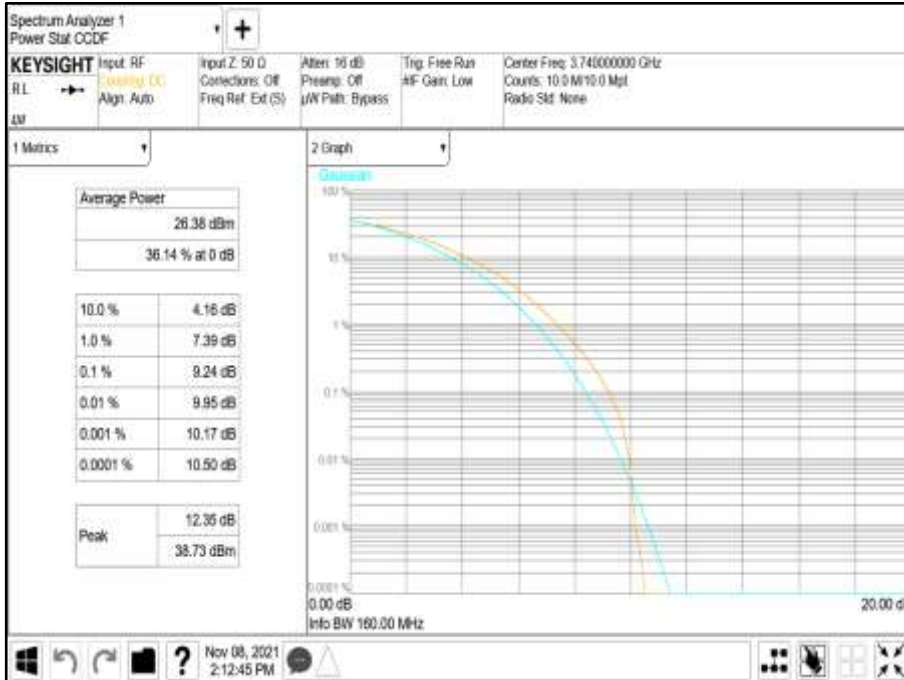

Antenna Port A PSD - Modulation NR: QPSK - Carrier Bandwidth 80.0 MHz - Channel Position B





Antenna Port A Carrier Power - Modulation NR: QPSK - Carrier Bandwidth 100.0 MHz - Channel Position B



Antenna Port A Pk-Av Ratio - Modulation NR: QPSK - Carrier Bandwidth 100.0 MHz - Channel Position B

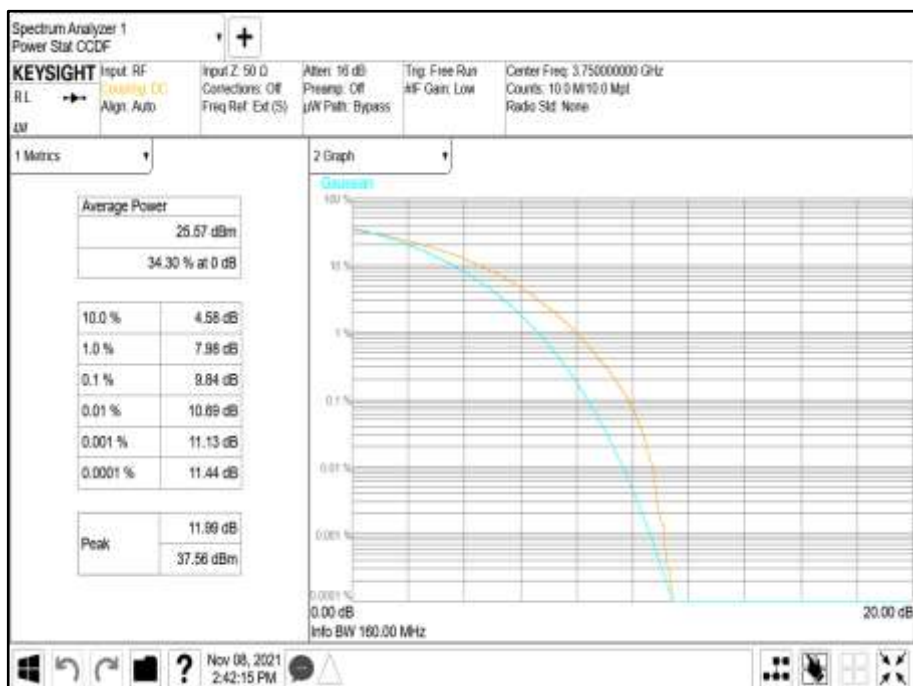



Antenna Port A PSD - Modulation NR: QPSK - Carrier Bandwidth 100.0 MHz - Channel Position B





Configuration B

Maximum Output Power 26.00 dBm / Port

Antenna Gain (dBi)	Modulation	Carrier Bandwidth	Output Power	
			Channel Position M	
Antenna Port			Average Power (dBm)	
			dBm	EIRP (dBm)
4.90				
A	NR20: QPSK	NR20.0+NR20.0 MHz	25.04	29.94
B	NR20: QPSK	NR20.0+NR20.0 MHz	25.30	30.20
C	NR20: QPSK	NR20.0+NR20.0 MHz	25.54	30.44
D	NR20: QPSK	NR20.0+NR20.0 MHz	25.77	30.67
Total			31.44	36.34
A	NR80: QPSK (NC)	NR80.0+NR80.0 MHz	25.32	30.22
B	NR80: QPSK (NC)	NR80.0+NR80.0 MHz	25.48	30.38
C	NR80: QPSK (NC)	NR80.0+NR80.0 MHz	25.38	30.28
D	NR80: QPSK (NC)	NR80.0+NR80.0 MHz	25.55	30.45
Total			31.45	36.35

Remarks

1. The table results are measured at all antenna ports.
2. The plot results represent typical radio performance across all channels.
3. Plot data performance for all transmitter ports and channels for both contiguous and non-contiguous (NC) operation are available on request.



Antenna Port C Carrier Power - Modulation NR20: QPSK - Carrier Bandwidth NR20.0+NR20.0 MHz - Channel Position M



Antenna Port A Carrier Power - Modulation NR80: QPSK (NC) - Carrier Bandwidth NR80.0+NR80.0 MHz - Channel Position M

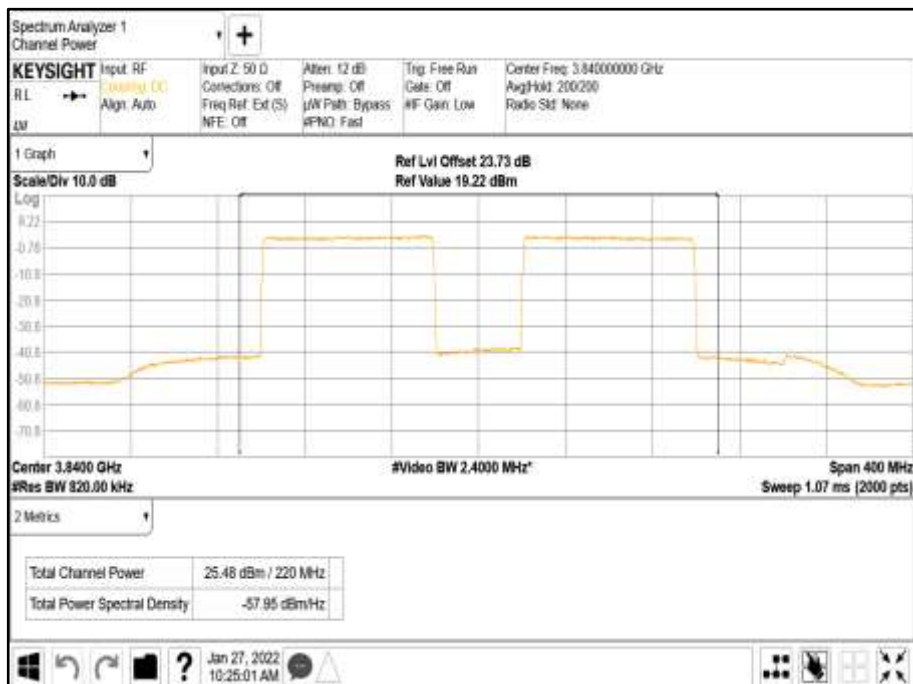



Configuration C

Maximum Output Power 26.00 dBm / Port

Antenna Gain (dBi)	Modulation	Carrier Bandwidth	Output Power	
			Channel Position M	
Antenna Port			Average Power (dBm)	
			dBm	EIRP (dBm)
4.90				
A	NR20: QPSK	20+20+20+20+20+20 MHz	25.26	30.16
B	NR20: QPSK	20+20+20+20+20+20 MHz	25.13	30.03
C	NR20: QPSK	20+20+20+20+20+20 MHz	25.37	30.27
D	NR20: QPSK	20+20+20+20+20+20 MHz	25.44	30.34
Total			31.32	36.22
A	NR20: QPSK (NC)	20+20+20+20+20+20 MHz	25.55	30.45
B	NR20: QPSK (NC)	20+20+20+20+20+20 MHz	25.45	30.35
C	NR20: QPSK (NC)	20+20+20+20+20+20 MHz	25.44	30.34
D	NR20: QPSK (NC)	20+20+20+20+20+20 MHz	25.72	30.57
Total			31.56	36.46

Remarks

1. The table results are measured at all antenna ports.
2. The plot results represent typical radio performance across all channels.
3. Plot data performance for all transmitter ports and channels for both contiguous and non-contiguous (NC) operation are available on request.



Antenna Port D Carrier Power - Modulation NR: QPSK - Carrier Bandwidth 20+20+20+20+20+20 MHz - Channel Position M

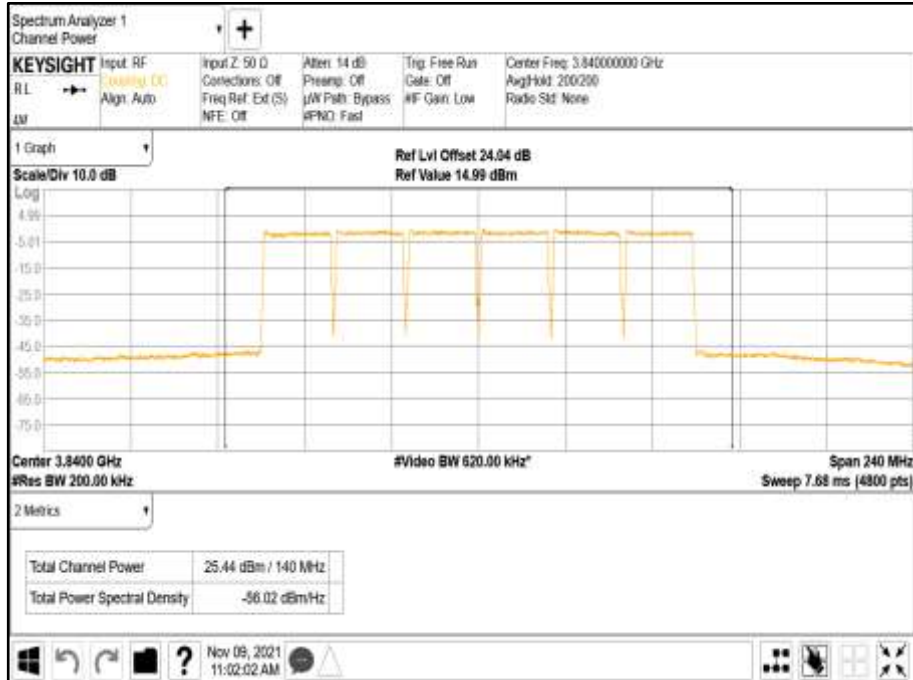

Antenna Port D Carrier Power - Modulation NR: QPSK (NC) - Carrier Bandwidth 20+20+20+20+20+20 MHz - Channel Position M

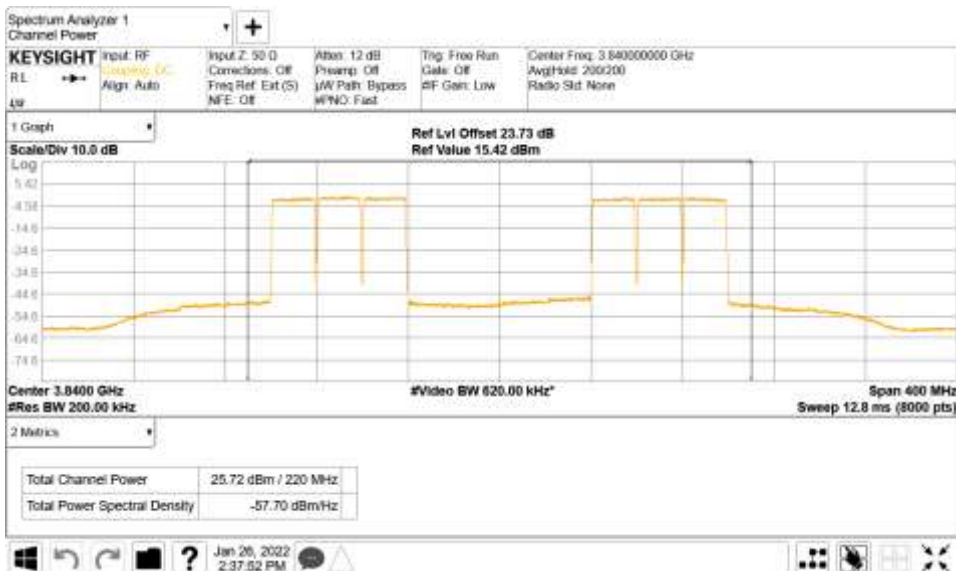

Limit	
Maximum rated output power (Non-Rural)	≤ 1640 W/MHz or ≤ +62.15 dBm/MHz
Maximum rated output power (Rural)	≤ 3280 W/MHz or ≤ +65.15 dBm/MHz
Peak to Average Ratio	13 dB



2.2 OCCUPIED BANDWIDTH

2.2.1 Specification Reference

FCC CFR 47 Part 27, Clause 27.53
FCC CFR 47 Part 2, Clause 2.1049

2.2.2 Date of Test and Modification State

11-August-2021 - Modification State 0

2.2.3 Test Equipment Used

The major items of test equipment used for the above tests are identified in Section 3.1.

2.2.4 Environmental Conditions

Ambient Temperature 24.6°C
Relative Humidity 30.8%

2.2.5 Test Method

All measurements were made in accordance with FCC KDB 971168 D01, Clause 4.2 and 4.3. The Spectrum Analyser RBW was configured to be at least 1% of the channel bandwidth of the carrier to be measured.

2.2.6 Test Results

Configuration A

Maximum Output Power 26.00 dBm / Port

Modulation	Carrier Bandwidth	Result (MHz)	
		Channel Bandwidth	
		Occupied Bandwidth	-26 dB Bandwidth
NR: QPSK	NR: 20.0 MHz	18.25	19.68
NR: QPSK	NR: 40.0 MHz	37.82	39.73
NR: QPSK	NR: 60.0 MHz	57.74	59.75
NR: QPSK	NR: 80.0 MHz	77.38	79.97
NR: QPSK	NR: 100.0 MHz	97.34	100.60

Remarks

Representative occupied bandwidth performance results presented. Plot data performance for all transmitter ports and channel positions are on file and available on request.



Antenna A - Modulation NR: QPSK - LTE Carrier Bandwidth NR: 20.0 MHz - Channel Position B

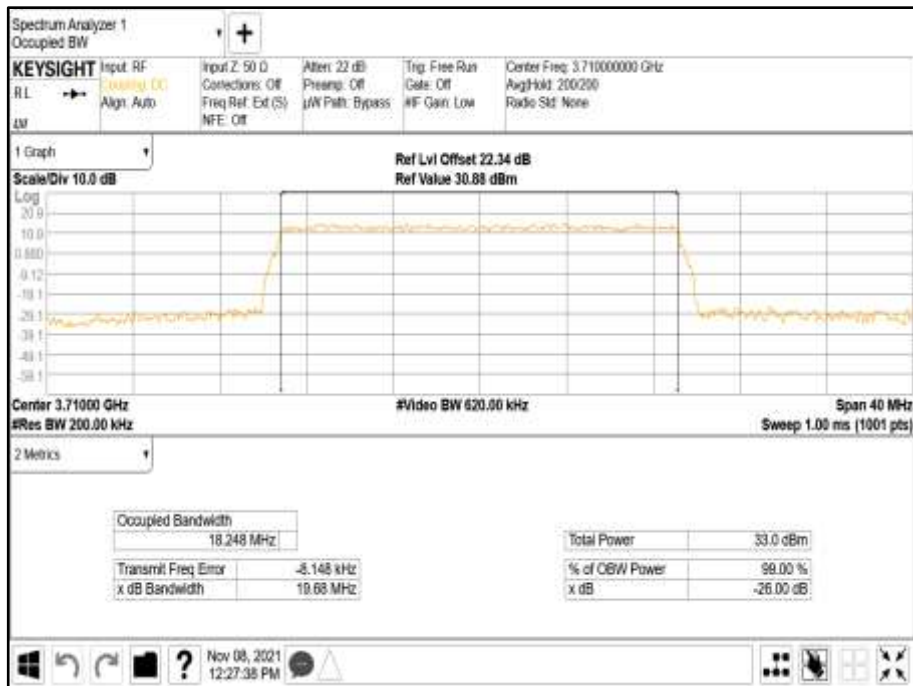



Antenna A - Modulation NR: QPSK - LTE Carrier Bandwidth NR: 40.0 MHz - Channel Position B

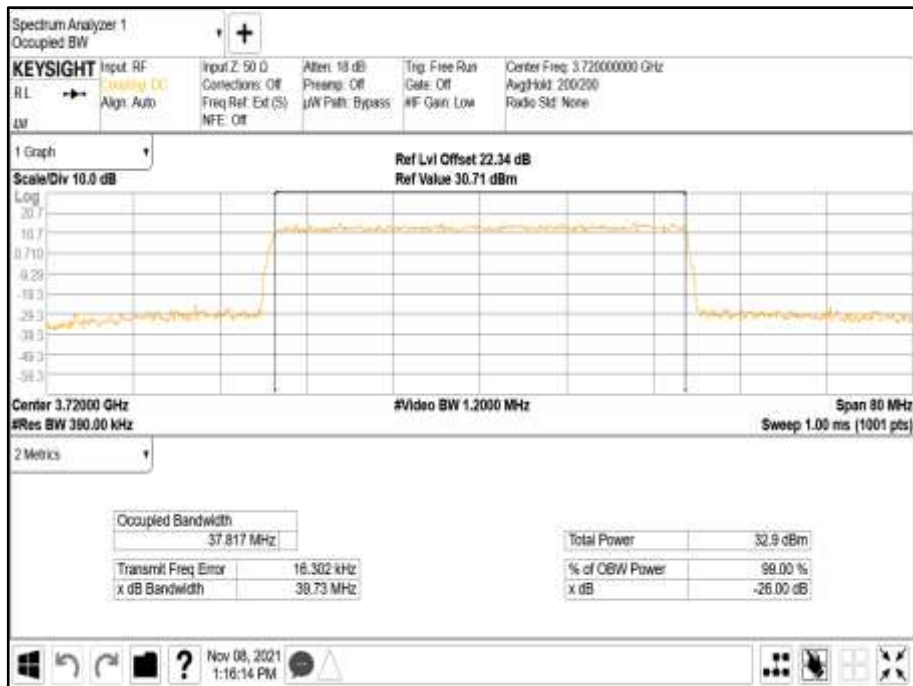

Antenna A - Modulation NR: QPSK - LTE Carrier Bandwidth NR: 60.0 MHz - Channel Position B

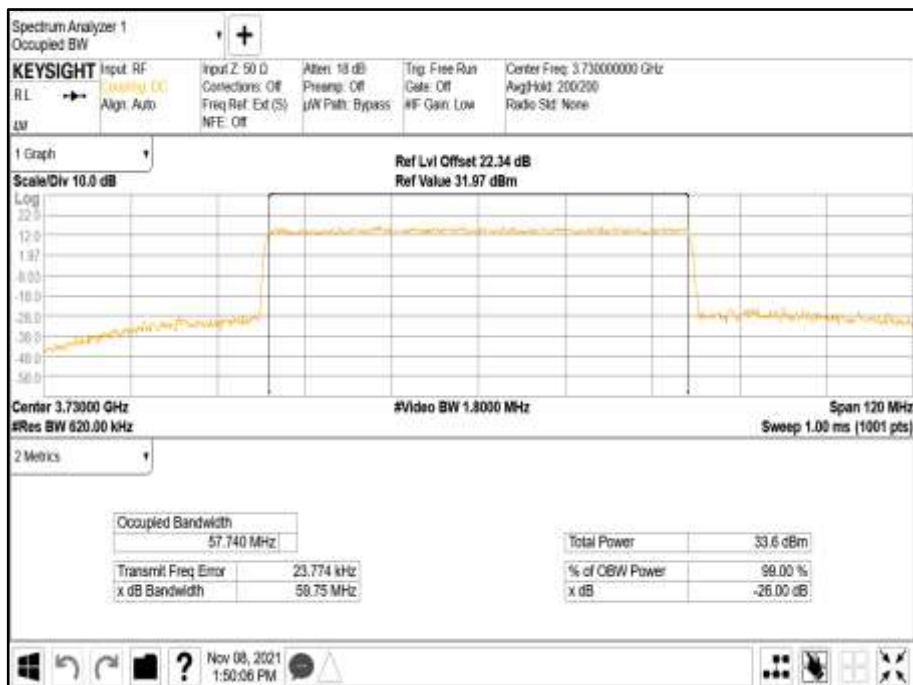



Antenna A - Modulation NR: QPSK - LTE Carrier Bandwidth NR: 80.0 MHz - Channel Position B

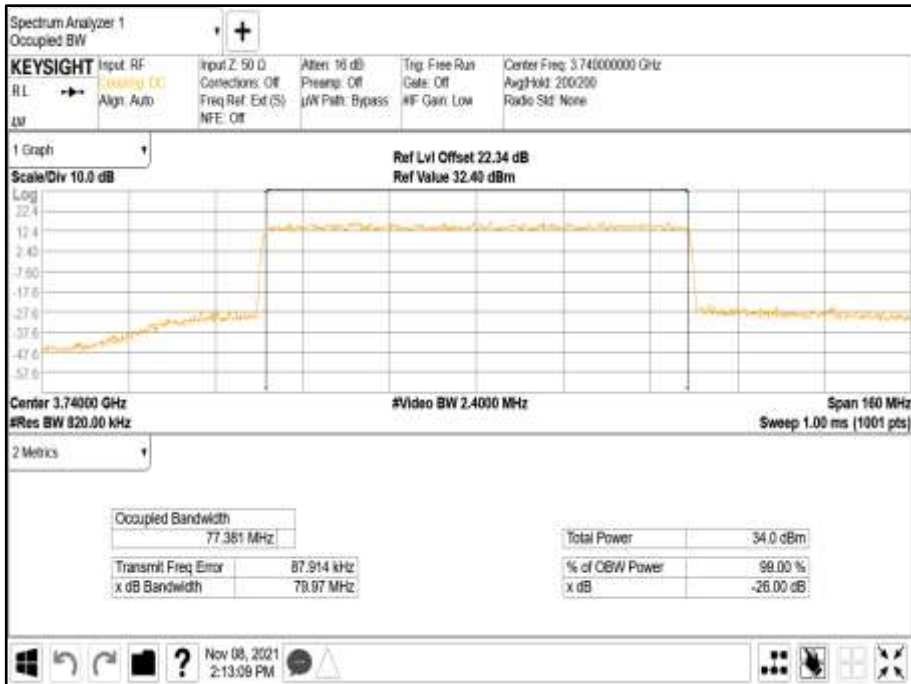

Antenna A - Modulation NR: QPSK - LTE Carrier Bandwidth NR: 100.0 MHz - Channel Position B

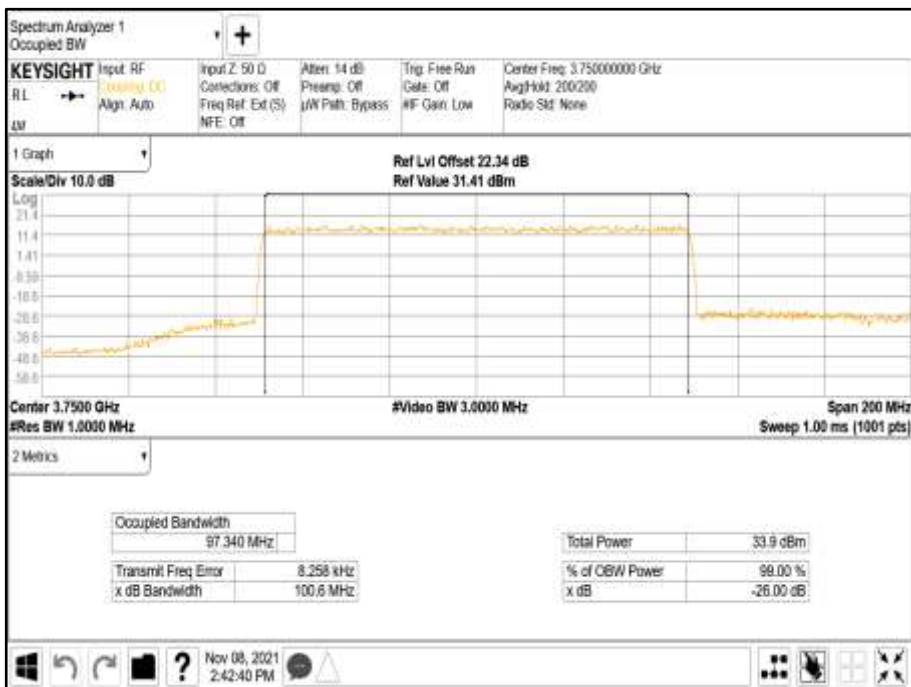



2.3 BAND EDGE

2.3.1 Specification Reference

FCC CFR 47 Part 27, Clause 27.53
FCC CFR 47 Part 2, Clause 2.1051

2.3.2 Date of Test and Modification State

11-August-2021 - Modification State 0

2.3.3 Test Equipment Used

The major items of test equipment used for the above tests are identified in Section 3.1.

2.3.4 Environmental Conditions

Ambient Temperature 24.6°C
Relative Humidity 30.8%

2.3.5 Test Method

All measurements were made in accordance with FCC KDB 971168 D01, Clause 6.0.

Band Edge measurements were used an Integration Bandwidth of at least 1% of the measured 26dB Bandwidth.

The product has 4 ports. To account for this, the limit was tightened by $10 * \text{Log}(N)$, where N is equal to the number of MIMO antenna ports.

For single port, the limit was calculated as being $-13 \text{ dBm} - 10 * \text{Log}(4) = -19 \text{ dBm}$.

2.3.6 Test Results

Configuration A

Maximum Output Power 26.00 dBm / Port

Antenna Port A	Modulation	Carrier Bandwidth	Band Edge (MHz)	
			Channel Position B	Channel Position T
A	NR: QPSK	NR: 20.0 MHz	3,710.0	3,970.0
A	NR: QPSK	NR: 40.0 MHz	3,720.0	3,960.0
A	NR: QPSK	NR: 60.0 MHz	3,730.0	3,950.0
A	NR: QPSK	NR: 80.0 MHz	3,740.0	3,940.0
A	NR: QPSK	NR: 100.0 MHz	3,750.0	3,930.0

Remarks

1. Bandedge data was captured from the transmit port with maximum measured power.
2. Worst case bandedge data presented.



Antenna Port A - Modulation NR: QPSK - Carrier Bandwidth NR: 20.0 MHz - Channel Position B

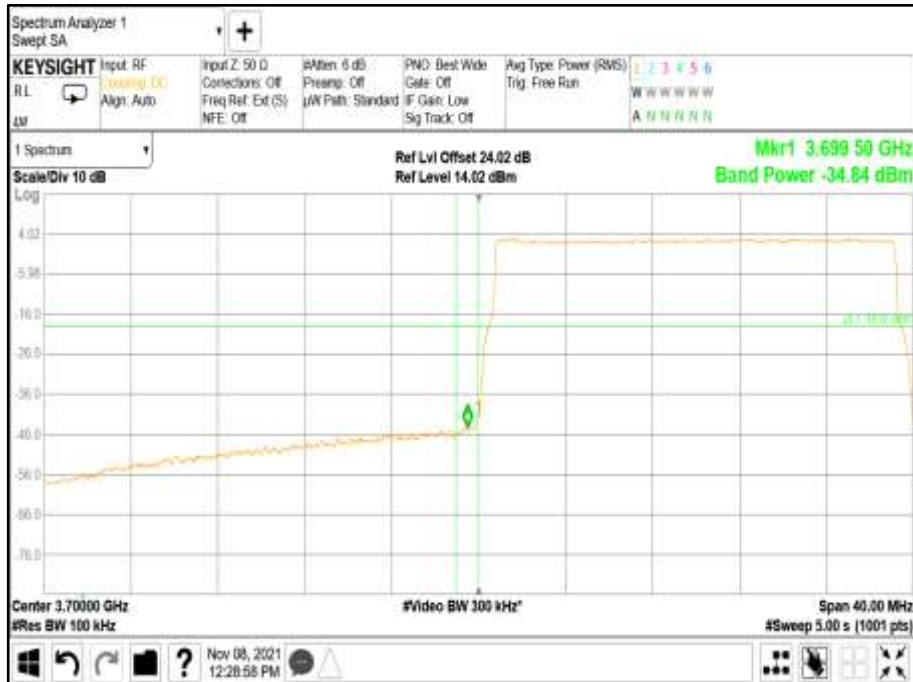

Antenna Port A - Modulation NR: QPSK - Carrier Bandwidth NR: 20.0 MHz - Channel Position I

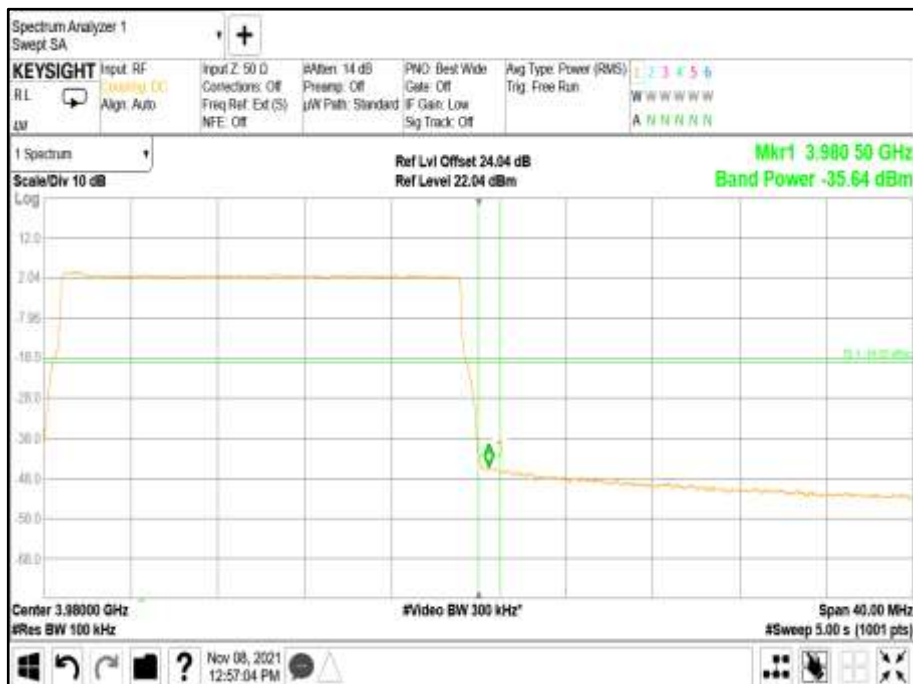



Antenna Port A - Modulation NR: QPSK - Carrier Bandwidth NR: 40.0 MHz - Channel Position B



Antenna Port A - Modulation NR: QPSK - Carrier Bandwidth NR: 40.0 MHz - Channel Position I





Antenna Port A - Modulation NR: QPSK - Carrier Bandwidth NR: 60.0 MHz - Channel Position B

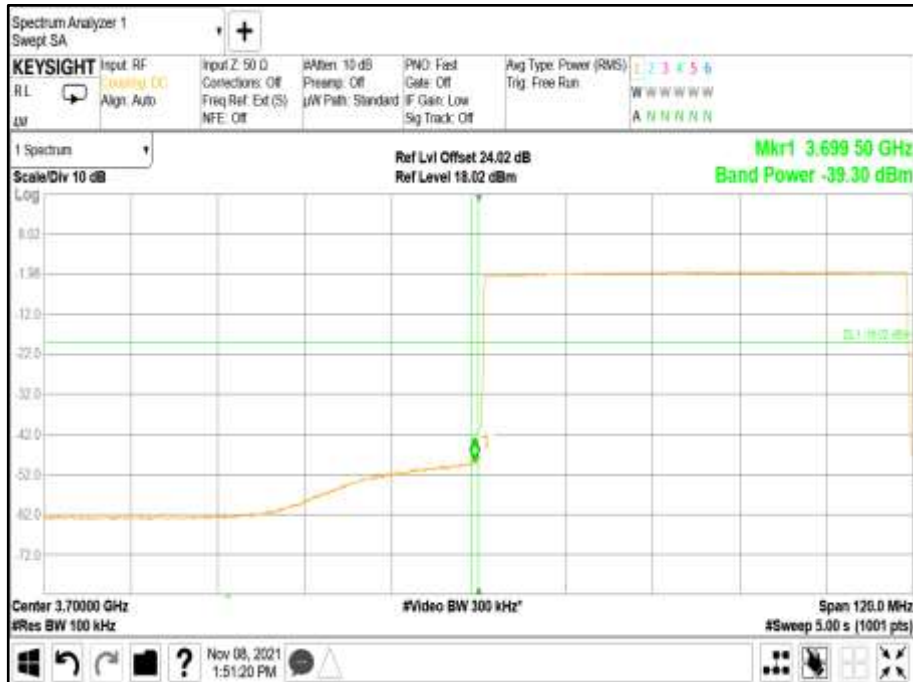

Antenna Port A - Modulation NR: QPSK - Carrier Bandwidth NR: 60.0 MHz - Channel Position I





Antenna Port A - Modulation NR: QPSK - Carrier Bandwidth NR: 80.0 MHz - Channel Position B

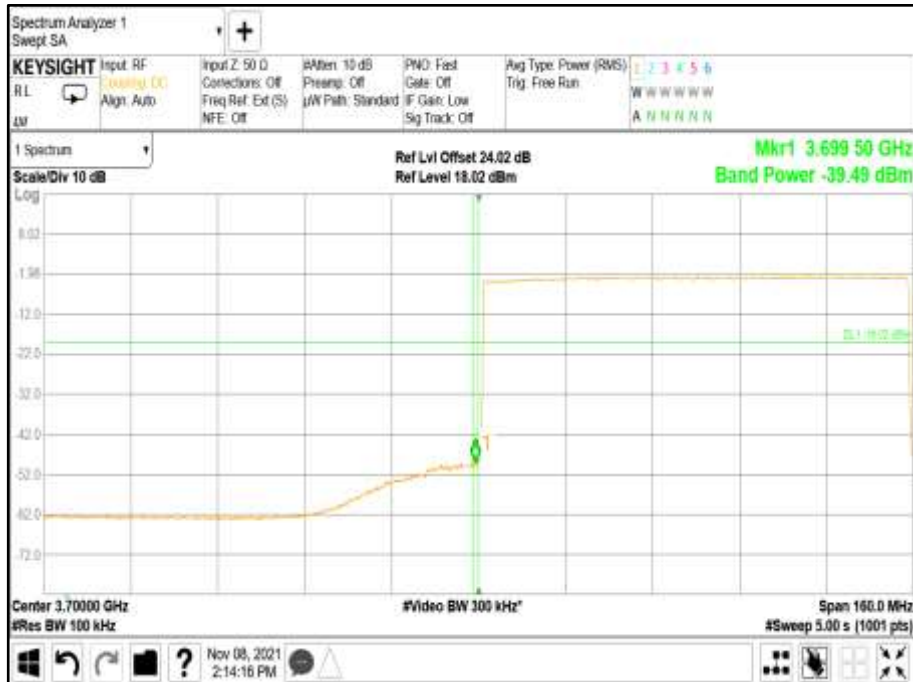

Antenna Port A - Modulation NR: QPSK - Carrier Bandwidth NR: 80.0 MHz - Channel Position I

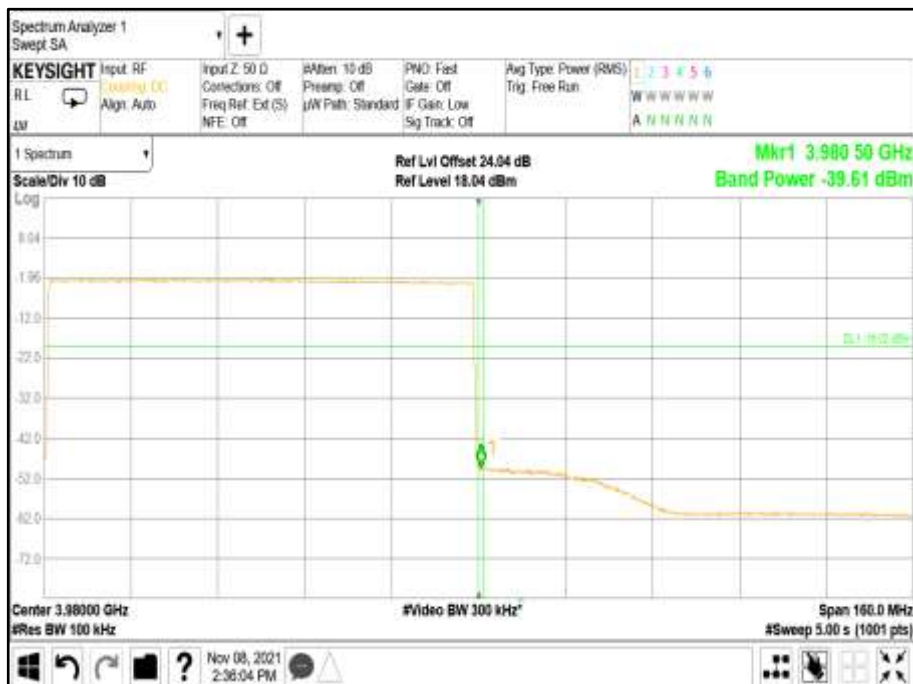



Antenna Port A - Modulation NR: QPSK - Carrier Bandwidth NR: 100.0 MHz - Channel Position B

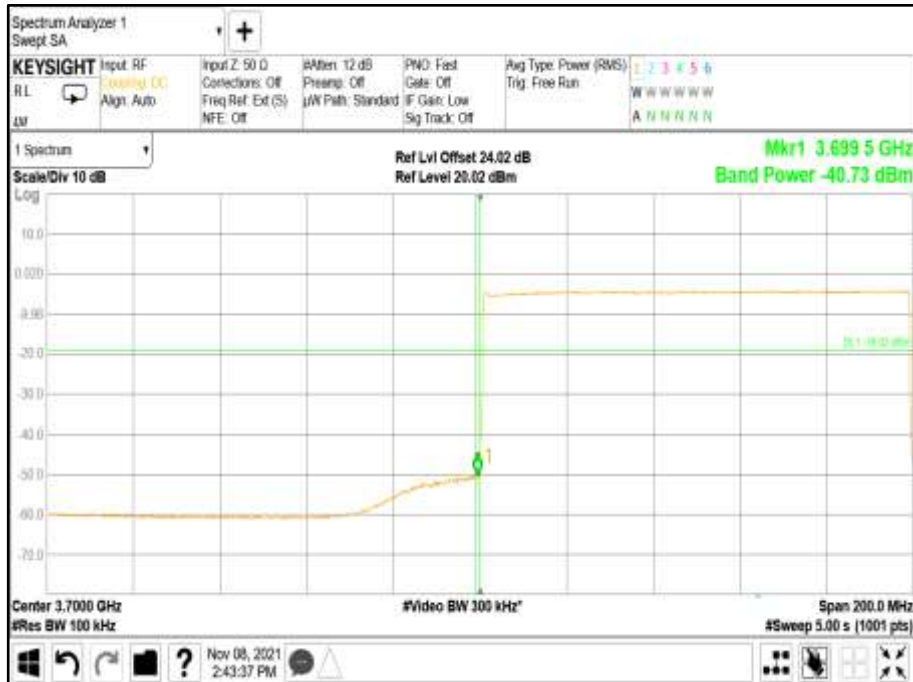

Antenna Port A - Modulation NR: QPSK - Carrier Bandwidth NR: 100.0 MHz - Channel Position I

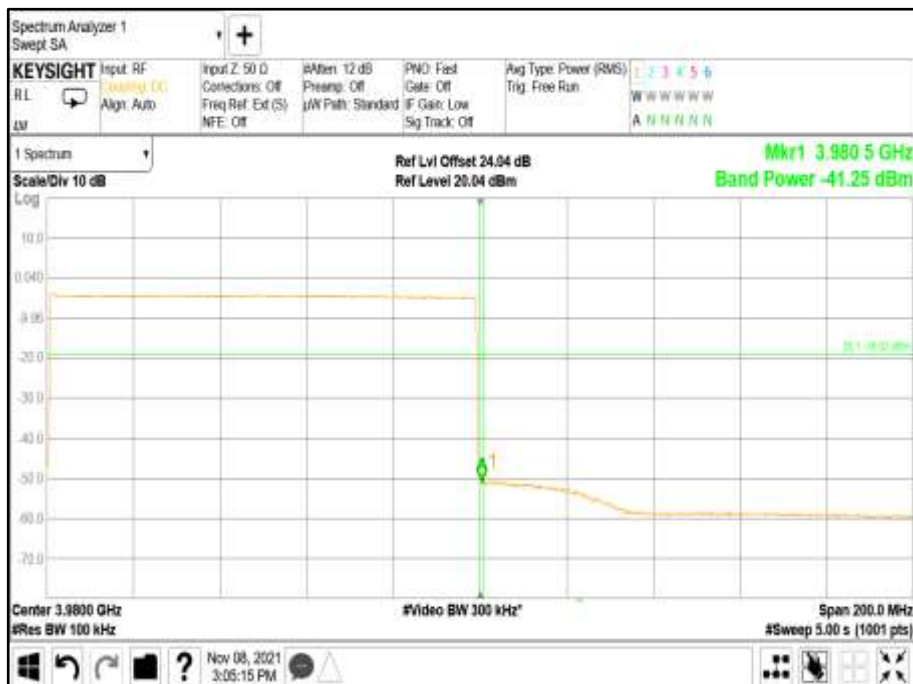



Configuration B

Maximum Output Power 26.00 dBm / Port

Antenna	Modulation	Carrier Bandwidth	Band Edge (MHz)	
			Channel Position B	Channel Position T
A	NR20: QPSK	NR20.0+NR20.0 MHz	3710.0+3730.0	3950.0+3970.0
A	NR80: QPSK (NC)	NR80.0+NR80.0 MHz	3740.0+3860.0	3820.0+3940.0

Remarks

The plot results represent typical radio performance.

Antenna Port A - Modulation NR20: QPSK - Carrier Bandwidth NR20.0+NR20.0 MHz - Channel Position B





Antenna Port A - Modulation NR20: QPSK - Carrier Bandwidth NR20.0+NR20.0 MHz - Channel Position T



Antenna Port A - Modulation NR80: QPSK (NC) - Carrier Bandwidth NR80.0+NR80.0 MHz - Channel Position B

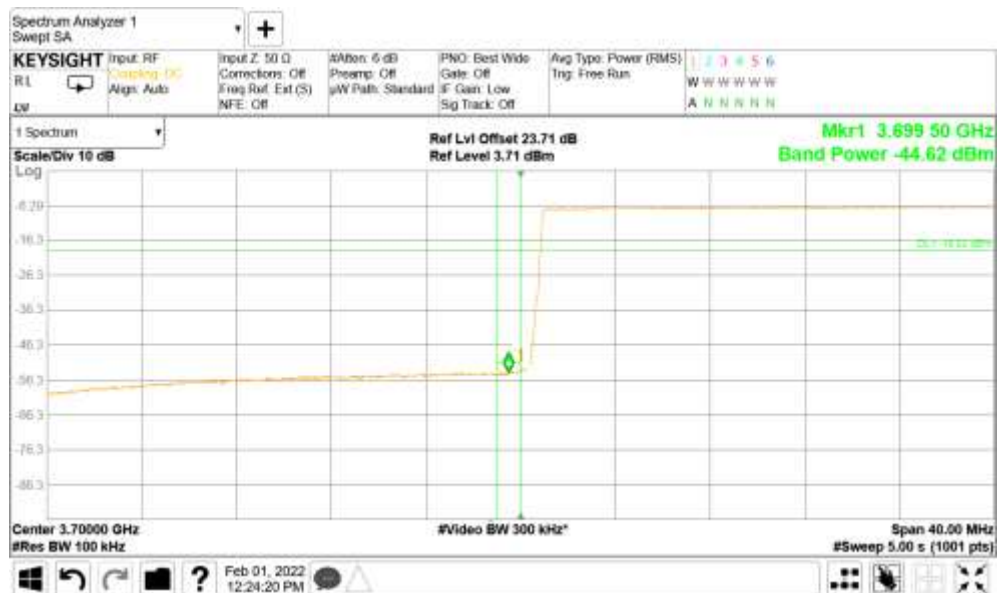



Antenna Port A - Modulation NR80: QPSK (NC) - Carrier Bandwidth NR80.0+NR80.0 MHz - Channel Position T



Configuration C

Maximum Output Power 26.00 dBm / Port

Antenna	Modulation	Carrier Bandwidth	Band Edge (MHz)	
			Channel Position B	Channel Position T
A	NR20: QPSK	20+20+20+20+20+20 MHz	3710+3730+3750+3770+3790+3810	3870+3890+3910+3930+3950+3970
A	NR20: QPSK	20+20+20+20+20+20 MHz	3710+3730+3750+3850+3870+3890	3790+3810+3830+3930+3950+3970

- Measurements for all configurations, contiguous and non-contiguous have been verified as compliant.
- Typical plot performance is presented.



- Antenna Port A - Modulation NR20: QPSK - Carrier Bandwidth 20+20+20+20+20+20 MHz - Channel Position B



- Antenna Port A - Modulation NR20: QPSK - Carrier Bandwidth 20+20+20+20+20+20 MHz - Channel Position T



FCC Part 27.50 Clauses (j)

Limit	-19 dBm
-------	---------



2.4 TRANSMITTER SPURIOUS EMISSIONS

2.4.1 Specification Reference

FCC CFR 47 Part 27, Clause 27.53
FCC CFR 47 Part 2, Clause 2.1051

2.4.2 Date of Test and Modification State

11-August-2021 - Modification State 0

2.4.3 Test Equipment Used

The major items of test equipment used for the above tests are identified in Section 3.1.

2.4.4 Environmental Conditions

Ambient Temperature 24.6°C
Relative Humidity 30.8%

2.4.5 Test Method

All measurements were made in accordance with FCC KDB 971168 D01, Clause 6.1.

This product has 4 ports. To account for this, the limit was tightened by $10 * \text{Log}(N)$, where N is equal to the number of MIMO antenna ports.

For single port, the limit was calculated as being $-13 \text{ dBm} - 10 * \text{Log}(4) = -19 \text{ dBm}$.

2.4.6 Test Results

Configuration A

Maximum Output Power 26.00 dBm / Port

Antenna	Modulation	Carrier Bandwidth	Channel Position	Band	Range
A	NR: QPSK	20.0 MHz	B	1	0.009 to 4000 MHz
A	NR: QPSK	20.0 MHz	B	2	4000 to 12000 MHz
A	NR: QPSK	20.0 MHz	B	3	12000 to 18000 MHz
A	NR: QPSK	20.0 MHz	B	4	18000 to 39800 MHz

Remarks

1. Transceiver spurious emissions have been searched for all channel bandwidths and antenna ports.

2. Representative spurious emissions performance using the most narrow channel bandwidth has been presented for all modulations. The smallest Ch BW has been found to result in the worst case performance.

3. Plot data performance for all channel bandwidths, and channel positions for both contiguous and non-contiguous (NC) operation are on file and available on request.

Antenna A - Modulation NR: QPSK - Carrier Bandwidth 20.0 MHz - Channel Position B - Band 1 - Range 0.009 to 4000 MHz

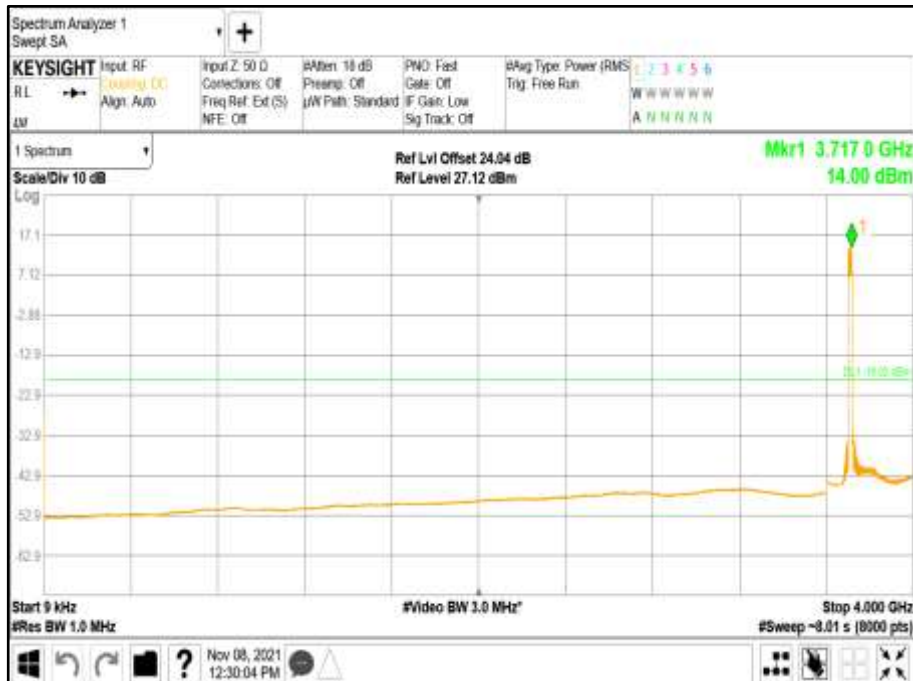

Antenna A - Modulation NR: QPSK - Carrier Bandwidth 20.0 MHz - Channel Position B - Band 2 - Range 4000 to 12000 MHz

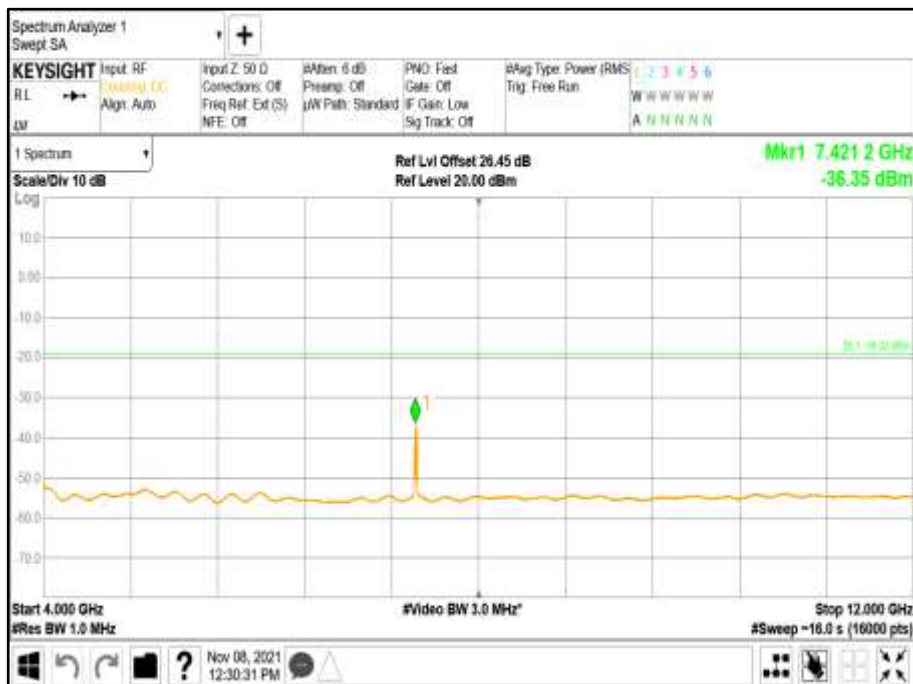



Antenna A - Modulation NR: QPSK - Carrier Bandwidth 20.0 MHz - Channel Position B - Band 3 - Range 12000 to 18000 MHz



Antenna A - Modulation NR: QPSK - Carrier Bandwidth 20.0 MHz - Channel Position B - Band 4 - Range 18000 to 39800 MHz

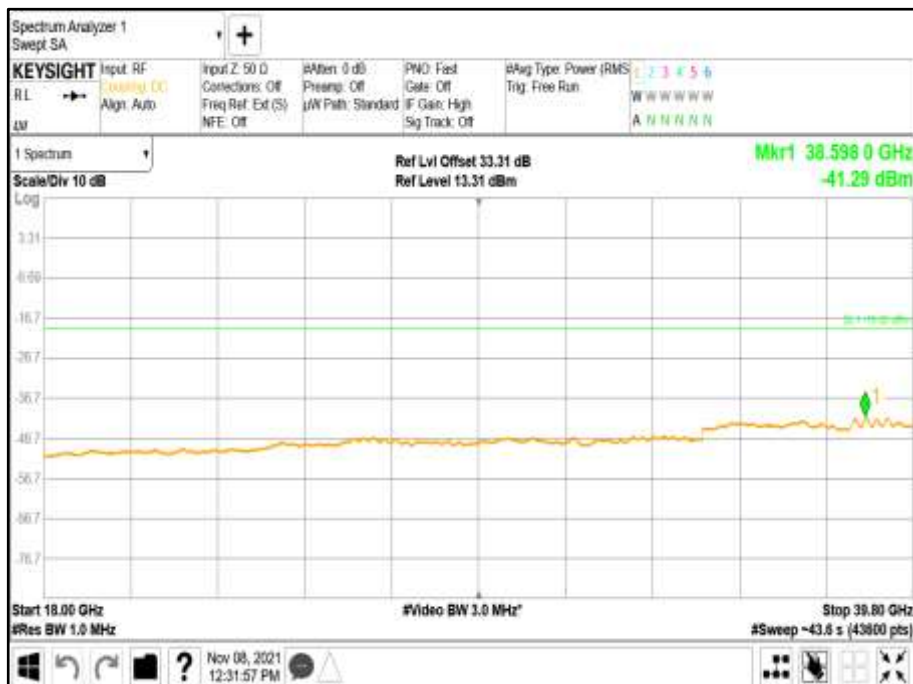



Configuration B

Maximum Output Power 26.00 dBm / Port

Antenna	Modulation	Carrier Bandwidth	Channel Position	Band	Range
A	NR20: QPSK	NR20.0+NR20.0 MHz	B	1	0.009 to 4000 MHz
A	NR20: QPSK	NR20.0+NR20.0 MHz	B	2	4000 to 12000 MHz
A	NR20: QPSK	NR20.0+NR20.0 MHz	B	3	12000 to 18000 MHz
A	NR20: QPSK	NR20.0+NR20.0 MHz	B	4	18000 to 39800 MHz
A	NR80: QPSK (NC)	NR80.0+NR80.0 MHz	B	1	0.009 to 4000 MHz
A	NR80: QPSK (NC)	NR80.0+NR80.0 MHz	B	2	4000 to 12000 MHz
A	NR80: QPSK (NC)	NR80.0+NR80.0 MHz	B	3	12000 to 18000 MHz
A	NR80: QPSK (NC)	NR80.0+NR80.0 MHz	B	4	18000 to 39800 MHz

Remarks

1. Transceiver spurious emissions have been searched for all channel bandwidths and antenna ports.
2. Representative spurious emissions performance using the most narrow channel bandwidth has been presented for all modulations. The smallest Ch BW has been found to result in the worst case performance.
3. Plot data performance for all channel bandwidths, and channel positions for both contiguous and non-contiguous (NC) operation are on file and available on request.



Antenna A - Modulation NR20: QPSK - Carrier Bandwidth NR20.0+NR20.0 MHz - Channel Position B - Band 1 - Range 0.009 to 4000 MHz



Antenna A - Modulation NR20: QPSK - Carrier Bandwidth NR20.0+NR20.0 MHz - Channel Position B - Band 2 - Range 4000 to 12000 MHz

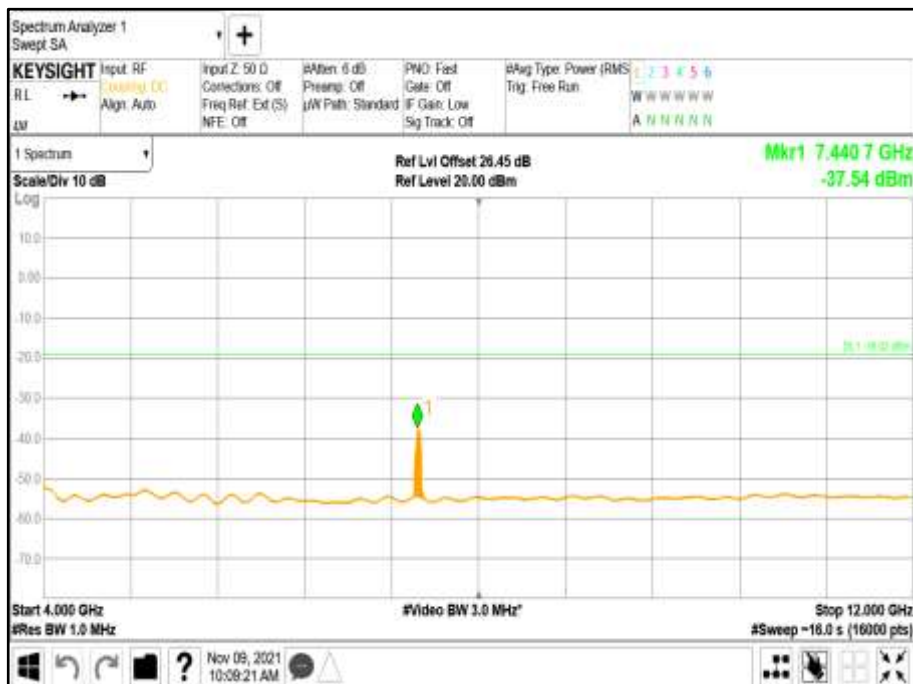



Antenna A - Modulation NR20: QPSK - Carrier Bandwidth NR20.0+NR20.0 MHz - Channel Position B - Band 3 - Range 12000 to 18000 MHz



Antenna A - Modulation NR20: QPSK - Carrier Bandwidth NR20.0+NR20.0 MHz - Channel Position B - Band 4 - Range 18000 to 39800 MHz





Antenna A - Modulation NR80: QPSK (NC) - Carrier Bandwidth NR80.0+NR80.0 MHz - Channel Position B - Band 1 - Range 0.009 to 4000 MHz



Antenna A - Modulation NR80: QPSK (NC) - Carrier Bandwidth NR80.0+NR80.0 MHz - Channel Position B - Band 2 - Range 4000 to 12000 MHz





Antenna A - Modulation NR80: QPSK (NC) - Carrier Bandwidth NR80.0+NR80.0 MHz - Channel Position B - Band 3 - Range 12000 to 18000 MHz



Antenna A - Modulation NR80: QPSK (NC) - Carrier Bandwidth NR80.0+NR80.0 MHz - Channel Position B - Band 4 - Range 18000 to 39800 MHz

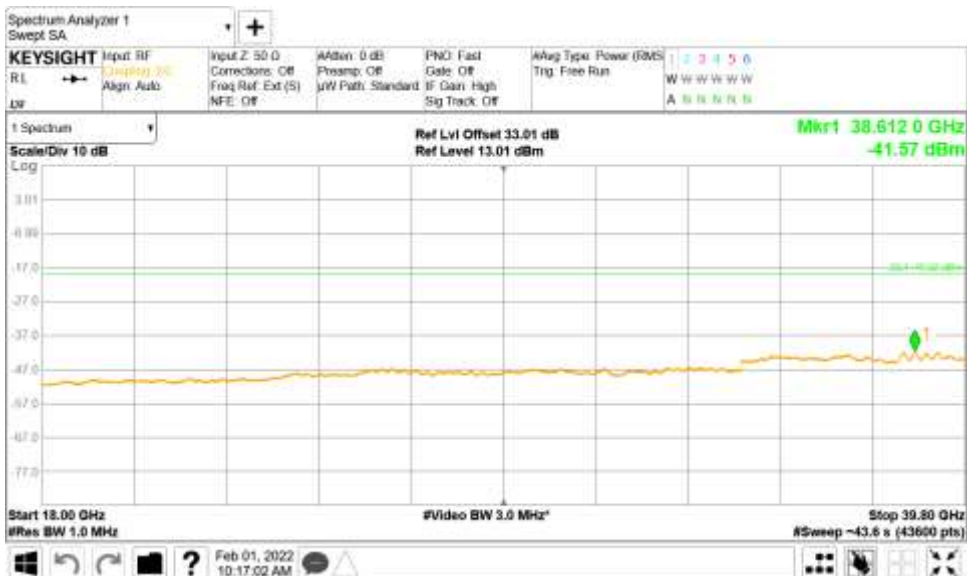



Configuration C

Maximum Output Power 26.00 dBm / Port

Antenna	Modulation	Carrier Bandwidth	Channel Position	Band	Range
A	NR20: QPSK	20+20+20+20+20+20 MHz	B	1	0.009 to 4000 MHz
A	NR20: QPSK	20+20+20+20+20+20 MHz	B	2	4000 to 12000 MHz
A	NR20: QPSK	20+20+20+20+20+20 MHz	B	3	12000 to 18000 MHz
A	NR20: QPSK	20+20+20+20+20+20 MHz	B	4	18000 to 38900 MHz

Remarks

1. Transceiver spurious emissions have been searched for all channel bandwidths and antenna ports.
2. Representative spurious emissions performance using the most narrow channel bandwidth has been presented for all modulations. The smallest Ch BW has been found to result in the worst case performance.
3. Plot data performance for all channel bandwidths, and channel positions for both contiguous and non-contiguous (NC) operation are on file and available on request.



Antenna A - Modulation NR20: QPSK - Carrier Bandwidth 20+20+20+20+20+20 MHz - Channel Position B - Band 1 - Range 0.009 to 4000 MHz



Antenna A - Modulation NR20: QPSK - Carrier Bandwidth 20+20+20+20+20+20 MHz - Channel Position B - Band 2 - Range 4000 to 12000 MHz

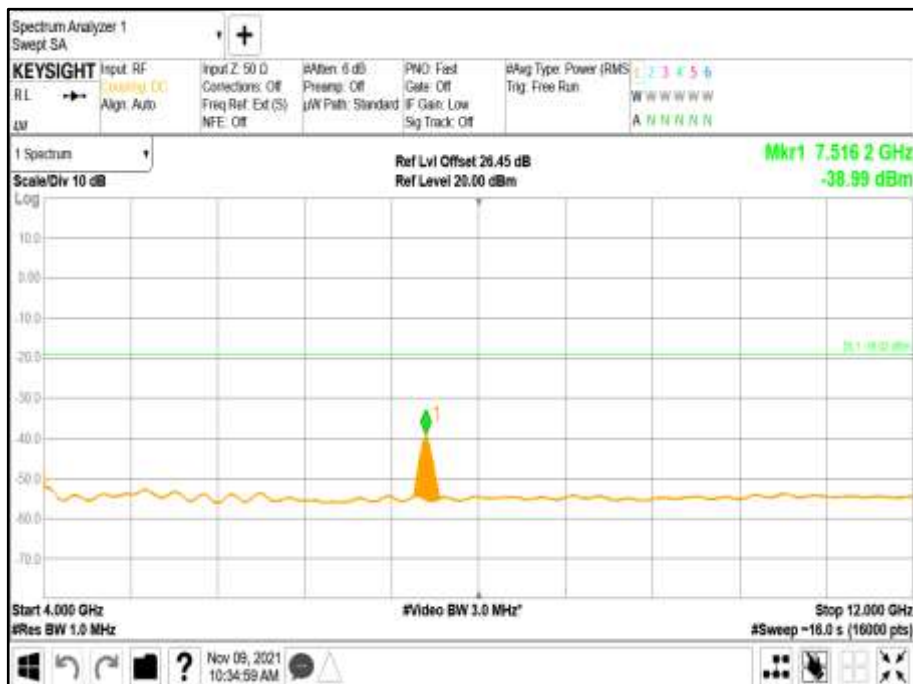



Antenna A - Modulation NR20: QPSK - Carrier Bandwidth 20+20+20+20+20+20 MHz - Channel Position B - Band 3 - Range 12000 to 18000 MHz



Antenna A - Modulation NR20: QPSK - Carrier Bandwidth 20+20+20+20+20+20 MHz - Channel Position B - Band 4 - Range 18000 to 38900 MHz

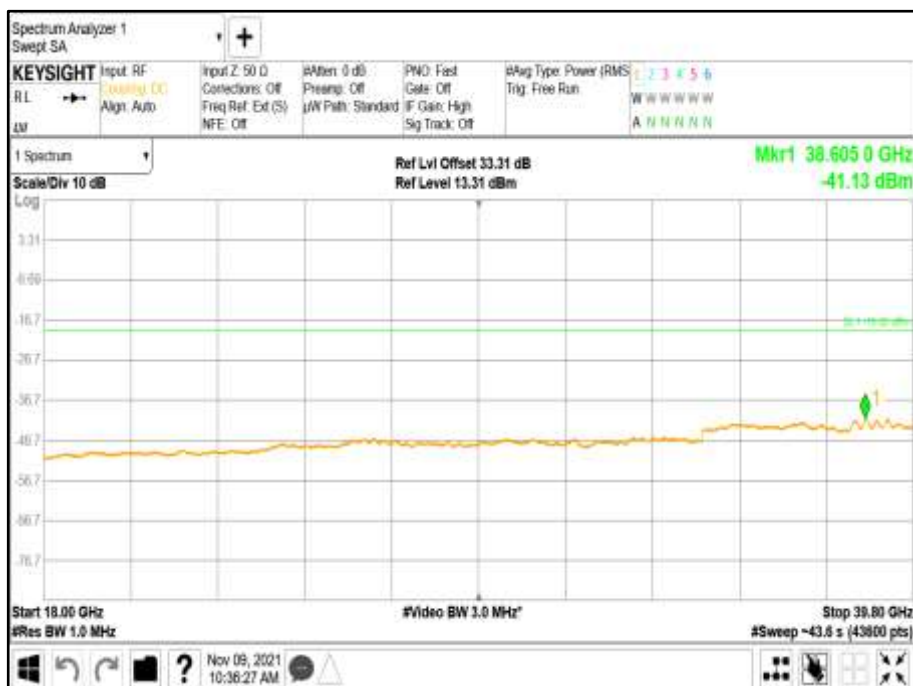

Limit	The power of any emission outside of the authorized operating frequency ranges must be attenuated below the transmitting power (P) by a factor of at least 43 + 10 log(P) db.
-------	---



2.5 FREQUENCY STABILITY

2.5.1 Specification Reference

FCC CFR 47 Part 2, Clause 2.1051

2.5.2 Date of Test and Modification State

11-August-2021 - Modification State 0

2.5.3 Test Equipment Used

The major items of test equipment used for the above tests are identified in Section 3.1.

2.5.4 Environmental Conditions

Ambient Temperature 24.6°C
Relative Humidity 30.8%

2.5.5 Test Method

All measurements were made in accordance with FCC KDB 971168 D01, Clause 9 and ANSI C63.26 Clause 5.6

2.5.6 Test Results

Configuration A

Maximum Output Power 26.00 dBm / Port

Temperature	Voltage	Frequency Error (Hz)
		Channel Position B (3 840 000 000 Hz)
-30°C	-48.0 V DC	Turns Off
-20°C	-48.0 V DC	Turns Off
-10°C	-48.0 V DC	1.7699
0°C	-48.0 V DC	2.8903
+10°C	-48.0 V DC	2.7228
+20°C	-40.5 V DC	2.7096
+20°C	-48.0 V DC	2.1851
+20°C	-57.5 V DC	1.1306
+30°C	-48.0 V DC	1.0311
+40°C	-48.0 V DC	-1.2185
+50°C	-48.0 V DC	-2.6671

Remarks

Worst Case deviation at 2.8903 Hz = 0.0007527 ppm



Limit	The frequency stability shall be sufficient to ensure that the fundamental emissions stay within the authorized bands of operation.
-------	---



SECTION 3

TEST EQUIPMENT USED



3.1 TEST EQUIPMENT USED

List of absolute measuring and other principal items of test equipment.

Instrument	Manufacturer	Type No.	TE No.	Calibration Period (months)	Calibration Due
Spectrum Analyzer	Keysight	PXA N9030B	MY57144347	24	24/04/2022
Thermometer / Refrigeration	VWR	89094-746	210697579	24	13-Aug-2023
PSU	Xantrex	XKW60-50	E00109862	-	O/P Mon
Digital Multimeter	Fluke	23	SSG012027	12	22/10/2022
Attenuator (20dB)	Mini-Circuits	BW-K10-2W44+	-	-	O/P Mon
Climate Chamber	Burnsco	RTC-37P-3-3	-07-07	-	O/P Mon

N/A – Not Applicable

O/P Mon – Output Monitored with Calibrated Equipment



3.2 MEASUREMENT UNCERTAINTY

For a 95% confidence level, the measurement uncertainties for defined systems are:-

Test Discipline	Frequency / Parameter	MU	
Conducted Maximum Peak Output Power	30 MHz to 20 GHz Amplitude	± 0.7 dB	
Conducted Emissions	30 MHz to 20 GHz Amplitude	± 2.1 dB	
Frequency Stability	30 MHz to 2 GHz	± 5.0 Hz	
Occupied Bandwidth	Up to 20 MHz Bandwidth	5 MHz Bandwidth	± 11547 Hz
		10 MHz Bandwidth	± 23094 Hz
		15 MHz Bandwidth	± 34641 Hz
		20 MHz Bandwidth	± 46188 Hz
Band Edge	30 MHz to 20 GHz Amplitude	±0.8 dB	
Radiated Spurious Emissions	30 MHz to 1 GHz	± 5.2 dB	
	1 GHz to 40GHz	± 6.3 dB	

Measurement Uncertainty Decision Rule

Determination of conformity with the specification limits is based on the decision rule according to IEC Guide 115:2007, Clause 4.4.3 and 4.5.1. (Procedure 2). The measurement results are directly compared with the test limit to determine conformance with the requirements of the standard.

Risk: The uncertainty of measurement about the measured result is negligible with regard to the final pass/fail decision. The measurement result can be directly compared with the test limit to determine conformance with the requirement (compare IEC Guide 115). The level of risk to falsely accept and falsely reject items is further described in ILAC-G8



SECTION 4

ACCREDITATION, DISCLAIMERS AND COPYRIGHT



4.1 ACCREDITATION, DISCLAIMERS AND COPYRIGHT



This report relates only to the actual item/items tested.

This report does not imply product endorsement by any government, accreditation agency, or TÜV SÜD Canada Inc.

Opinions or interpretations expressed in this report, if any, are outside the scope of TÜV SÜD Canada Inc. accreditations. Any opinions expressed do not necessarily reflect the opinions of TÜV SÜD Canada Inc., unless otherwise stated.

This report relates only to the actual item/items tested

© 2022 TÜV SÜD

ANNEX A

MODULE LIST

Configuration A/B/C			
Product	Product No	R-State	Serial No
DOT 41Kr B77D (EUT)	KRY 901 515/4	R1B	on file
DOT 41Kr B77D (EUT)	KRY 901 515/4	R1B	on file
CT11	LPC 102 494/1	R2A	T01G495060
IRU 16Fr	KRC 161 842/7	R1A	on file
IRU 1649	KRC 161 842/2	R1D	TD3F105272
Software Version:	CXP2030045/26	Revision:	R12A108