

Contact person
Jörgen Wassholm
Electronics
+46 10 516 57 06
jorgen.wassholm@sp.se

Date Reference Page
2015-02-13 4P08534-01-F24 1 (2)

Ericsson AB
Niklas Warnström
PDU HW
Torshamnsgatan 21
164 83 Stockholm

Radio measurements on RD 2242 B2 with FCC ID TA8AKRY901328-1 and IC:287AB-AS9013281

(9 appendices)

Test object

Product name: RD 2242 B2
Product number: KRY 901 328/1

Summary

See appendix 1 for general information and appendix 9 for external photos.

Standard	Compliant	Appendix
FCC CFR 47 part 2 and 24 / IC RSS-133 Issue 6		
2.1046 / RSS-133 6.4 RF power output conducted	Yes	2
2.1046 / RSS-133 6.4 RF power output radiated	Yes	3
2.1049 / RSS-Gen 6.6 Occupied bandwidth	Yes	4
2.1051 / RSS-133 6.5 Band edge	Yes	5
2.1051 / RSS-133 6.5 Spurious emission at antenna terminals	Yes	6
2.1053 / RSS-133 6.5 Field strength of spurious radiation	Yes	7
2.1055 / RSS-133 6.3 Frequency stability	Yes	8

Note: Above RSS-133 items are given as cross-reference only. Measurements were performed according to ANSI procedures referenced by FCC and covered by SP's accreditation.

SP Technical Research Institute of Sweden

Electronics - EMC

Performed by

Examined by

Jörgen Wassholm

Anders Nordlöf

SP Technical Research Institute of Sweden

Postal address

SP
Box 857
SE-501 15 BORÅS
Sweden

Office location

Västeråsen
Brinellgatan 4
SE-504 62 BORÅS

Phone / Fax / E-mail

+46 10 516 50 00
+46 33 13 55 02
info@sp.se

Laboratories are accredited by the Swedish Board for Accreditation and Conformity Assessment (SWEDAC) under the terms of Swedish legislation. This report may not be reproduced other than in full, except with the prior written approval of the issuing laboratory.

Table of contents

Description of the test object	Appendix 1
Operation mode during measurements	Appendix 1
Test setups	Appendix 1
Purpose of test	Appendix 1
RF power output conducted	Appendix 2
RF power output radiated	Appendix 3
Occupied bandwidth	Appendix 4
Band edge	Appendix 5
Spurious emission at antenna terminals	Appendix 6
Field strength of spurious radiation	Appendix 7
Frequency stability	Appendix 8
External photos	Appendix 9

Appendix 1

Description of the test object

Radio equipment:	RD 2242 B2 Product number: KRY 901 328/1 FCC ID TA8AKRY901328-1 IC 287AB-AS9013281 IC MODEL NO: AS9013281
Hardware revision state:	R2B
Tested configuration:	LTE single RAT
Frequency bands:	TX: 1930 – 1990 MHz RX: 1850 – 1910 MHz
Antenna ports:	2 TX/RX ports, (internally connected to integrated Omni directional antenna elements)
RF configuration:	Single carrier, multi carrier, TX-diversity and MIMO 2x2
RF power tolerance	+2.7/ -4.3dB
Nominal output power per antenna port:	Single carrier: 1x 17 dBm (1 x 50mW) Multi carrier: 2 x 14 dBm (2 x 25mW)
Antenna type:	Omni directional antenna
Antenna gain:	+3 dBi
Channel bandwidths:	Singel carrier: 5 MHz, 10 MHz, 15 MHz and 20 MHz Multi carrier: 5 MHz, 10 MHz, 15 MHz and 20 MHz
Modulations:	QPSK, 16QAM and 64QAM
Nominal supply voltage:	-48VDC (associated equipment)

Appendix 1

Operation mode during measurements

Measurements were performed with the test object transmitting test models as defined in 3GPP TS 36.141. Test model E-TM1.1 represent QPSK modulation, test model E-TM3.2 represent 16QAM modulation and test model E-TM3.1 represent 64QAM modulation.

The settings below were deemed representative for all traffic scenarios when settings with different modulations, channel bandwidths, number of carriers and RF configurations has been tested to find the worst case setting. All measurements were performed with the test object configured for maximum transmit power. The settings below were used for all measurements if not otherwise noted.

MIMO mode, single carrier, E-TM1.1

MIMO mode, multi carrier, 2 carriers, E-TM1.1

Cable configurations between RD and IRU

The cables, used during tests, correspond to minimum and maximum length, according to clause 2.9 in Exhibit 12 – Technical Circuit Description. The following cable configurations has been used:

RDI Cable 20 m: total cable length 20 m patch cables included.

RDI Cable 92 m: total cable length 92 m patch cables included.

RDI Cable 200 m: total cable length 200 m patch cables included.

Patch cable	Cat 6a Schneider Electric Actassi CL-MNC6A
RDI cable	Cat 6a Schneider Electric Actassi CL-MXC6A

Conducted measurements

The conducted measurements were performed on RD 2242 B2 with product number KRY 901 328/1.

The test object was mounted in a fixture and powered by the RBS Main Unit via the RDI LAN cable.

All TX parameters were measured at port RF B with port RF A terminated into 50 ohm. Complete measurements were made on RF B, limited measurements on RF A.

Radiated measurements

The test object was mounted in a fixture and powered by the RBS Main Unit via the 200 m RDI LAN cable representing worst case. In field strength of spurious radiation both RF ports were terminated into 50 ohm. For RF power output measurement the internal antenna was used.

Appendix 1

Purpose of test

The purpose of the tests is to verify compliance to the performance characteristics specified in applicable items of FCC CFR 47 and Industry Canada RSS-133 and RSS-Gen.

References

Measurements were done according to relevant parts of the following standards:

ANSI 63.4 2009

ANSI/TIA -603-C 2004

CFR 47 part 2, October 1st, 2013

CFR 47 part 24, October 1st, 2013

3GPP TS 36.141, version 11.4.0

RSS-Gen Issue 4

RSS-133 Issue 6

Appendix 1

Uncertainties

Measurement and test instrument uncertainties are described in the quality assurance documentation "SP-QD 10885". The uncertainties are calculated with a coverage factor $k=2$ (95% level of confidence).

Compliance evaluation is based on a shared risk principle with respect to the measurement uncertainty.

Reservation

The test results in this report apply only to the particular test object as declared in the report.

Delivery of test object

The test object was delivered 2015-01-19.

Manufacturer's representative

Lars Wallin, Ericsson AB.

Test engineers

Andreas Johnson, Maulo Rivera, Tomas Isbring, Patric Augustsson and Jörgen Wassholm, SP.

Test participant

None.

Appendix 1

Measurement equipment

	Calibration Due	SP number
Semi anechoic chamber, Tesla	2015-12	503 881
R&S ESU 26	2015-08	901 553
R&S FSQ 40	2015-07	504 143
R&S FSW 43	2015-07	902 073
Control computer with R&S software EMC32 ver. 9.15.0	-	- 503 889
High pass filter	2015-12	BX40074
High pass filter	2015-07	901 501
High pass filter	2015-07	901 502
High pass filter	2015-07	504 199
High pass filter	2015-07	901 373
High pass filter	2016-07	503 739
High pass filter	2015-07	503 740
High pass filter	2015-07	504 200
RF attenuator	2016-07	503 248
RF attenuator	2016-06	503 249
RF attenuator	2015-08	504 159
RF attenuator	2015-07	900 233
RF attenuator	2015-11	900 691
RF attenuator	2015-06	901 384
Chase Bilog Antenna CBL 6111A	2017-10	503 182
EMCO Horn Antenna 3115	2016-09	502 175
µComp Nordic, Low Noise Amplifier	2016-01	901 545
Flann STD Gain Horn Antenna 16-240	-	503 939
Flann STD Gain Horn Antenna 18-240	-	503 900
Flann STD Gain Horn Antenna 20240-20	-	503 674
Schwarzbeck preamplifier BBV 9742	2015-12	504 085
Temperature and humidity meter, Testo 635	2015-03	504 203
Temperature and humidity meter, Testo 625	2015-06	504 188
Temperature Chamber	-	503 360
Multimeter Fluke 87	2015-08	502 190

Appendix 1

Test frequencies used for conducted and radiated measurements

TX test frequencies, single carrier:

EARFCN Downlink	Frequency [MHz]	Symbolic name	Comment
625	1932.5	B	TX bottom frequency in 5 MHz BW configuration
650	1935.0	B	TX bottom frequency in 10 MHz BW configuration.
675	1937.5	B	TX bottom frequency in 15 MHz BW configuration.
700	1940.0	B	TX bottom frequency in 20 MHz BW configuration.
900	1960.0	M	TX band mid frequency all BW configurations
1100	1980.0	T	TX top frequency in 20 MHz BW configuration.
1125	1982.5	T	TX top frequency in 15 MHz BW configuration.
1150	1985.0	T	TX top frequency in 10 MHz BW configuration.
1175	1987.5	T	TX top frequency in 5 MHz BW configuration

Appendix 1

TX test frequencies, multi carrier:

EARFCN Downlink	Frequency [MHz]	Symbolic name	Comment
625 675	1932.5 1937.5	B2-5	TX bottom frequency in 5 MHz BW configuration 2 carriers.
650 750	1935.0 1945.0	B2-10	TX bottom frequency in 10 MHz BW configuration 2 carriers.
675 825	1937.5 1952.5	B2-15	TX bottom frequency in 15 MHz BW configuration 2 carriers.
700 900	1940.0 1960.0	B2-20	TX bottom frequency in 20 MHz BW configuration 2 carriers.
875 925	1957.5 1962.5	M2-5	TX mid frequency in 5 MHz BW configuration 2 carriers.
850 950	1955.0 1965.0	M2-10	TX mid frequency in 10 MHz BW configuration 2 carriers.
825 975	1952.5 1967.5	M2-15	TX mid frequency in 15 MHz BW configuration 2 carriers.
800 1000	1950.0 1970.0	M2-20	TX mid frequency in 20 MHz BW configuration 2 carriers.
1125 1175	1982.5 1987.5	T2-5	TX Top frequency in 5 MHz BW configuration 2 carriers.
1000 1175	1970.0 1987.5	T2-5 ₂	TX Top frequency in 5 MHz BW configuration 2 carriers.
1050 1150	1975.0 1985.0	T2-10	TX Top frequency in 10 MHz BW configuration 2 carriers.
975 1125	1967.5 1982.5	T2-15	TX Top frequency in 15 MHz BW configuration 2 carriers.
900 1100	1960.0 1980.0	T2-20	TX Top frequency in 20 MHz BW configuration 2 carriers.
675 762	1937.5 1946.2	B2im1	TX bottom frequency in 5 MHz BW configuration 2 carriers.
1038 1125	1973.8 1982.5	T2im1	TX Top frequency in 5 MHz BW configuration 2 carriers.
796 1004	1949.6 1970.4	B2/T2im2	TX Mid frequency in 5 MHz BW configuration 2 carriers.

All RX frequencies were configured 80 MHz below the corresponding TX frequency according the applicable duplex offset for the operating band.

Appendix 1

Test setup conducted measurements

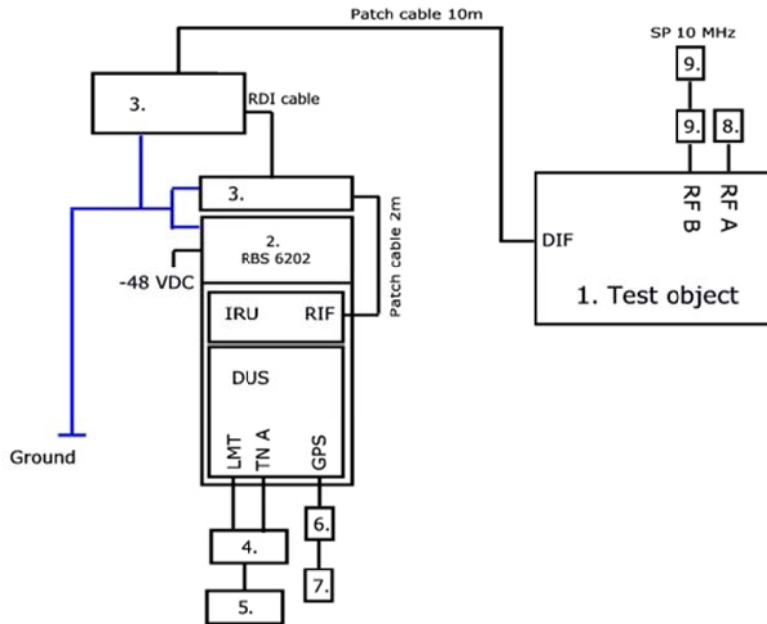

Test object

1.	RD 2242 B4, KRY 901 328/1, revision R2B, s/n: C828953704 (FCC ID: TA8AKRY901328-1 and IC: 287AB-AS9013281) with software: CXP 901 3268/14, revision R59FC
----	---

Associated equipment:

2.	RBS 6202: BYB 911 40/1, revision R3B, s/n: TU8J525857 DUS 41 01, KDU 137 624/1, revision R5A/A, s/n: D16H559114 IRU 2242, KRC 161 444/1, revision R1C, s/n: C828558497
3.	Patch panel, BGK 901 55/1, revision R1A, s/n: -
6.	GPS 02 01, NCD 901 41/1, revision R1D, s/n: TU8K474887
7.	GPS Active Antenna, KRE 101 2082/1

Functional test equipment:

4.	Switch Netgear FS726T
5.	Laptop EliteBook 8540w
8.	Attenuator/ Terminator 50 ohm
9.	SP test instrument according measurement equipment list

Appendix 1

Test setup radiated measurements

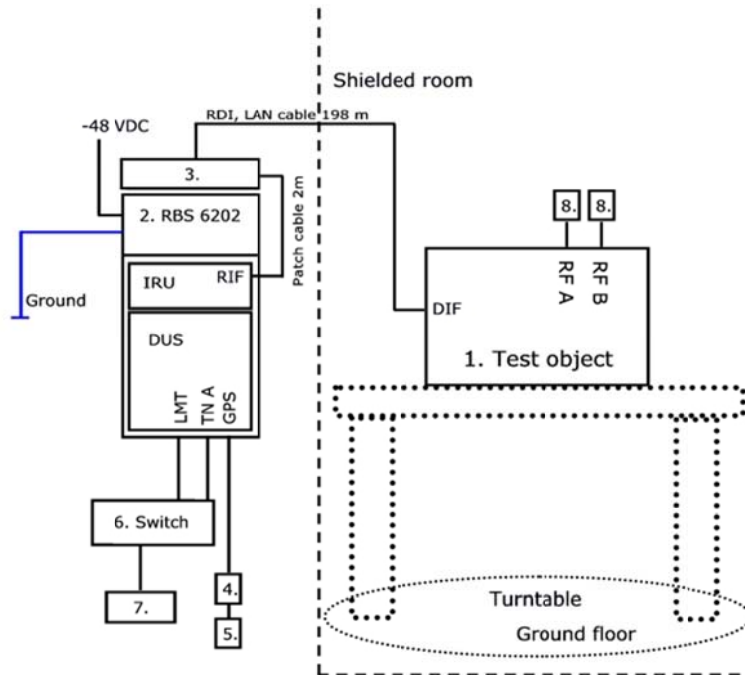

Test object

1.	RD 2242 B4, KRY 901 328/1, revision R2B, s/n: C828953704 (FCC ID: TA8AKRY901328-1 and IC: 287AB-AS9013281) with software: CXP 901 3268/14, revision R59FC
----	---

Associated equipment:

2.	RBS 6202: BYB 911 40/1, revision R3B, s/n: TU8J525857 DUS 41 01, KDU 137 624/1, revision R5A/A, s/n: D16H559114 IRU 2242, KRC 161 444/1, revision R1C, s/n: C828558497
3.	Patch panel, BGK 901 55/1, revision R1A, s/n: -
6.	GPS 02 01, NCD 901 41/1, revision R1D, s/n: TU8KH76616
7.	GPS Active Antenna, KRE 101 2082/1

Functional test equipment:

6.	Netgear switch FS726T
7.	HP Elitebook 8540w
8.	Attenuator/ Terminator 50 ohm

Appendix 1

Interfaces:	Type of port:
Antenna port (A), Hirose connector	Antenna
Antenna port (B), Hirose connector	Antenna
DIF, Patch cable Cat 6a Schneider Electric Actassi CL-MNC6A	Signal

RBS software:

Software	Revision
CXP 102 051/22	R46AL

Appendix 2

RF power output measurements according to CFR 47 §24.232 / IC RSS-133 6.4, conducted

Date	Temperature	Humidity
2015-01-20	22 °C ± 3 °C	20 % ± 5 %
2015-01-21	22 °C ± 3 °C	20 % ± 5 %
2015-01-22	21 °C ± 3 °C	20 % ± 5 %
2015-01-23	22 °C ± 3 °C	18 % ± 5 %
2015-01-26	22 °C ± 3 °C	18 % ± 5 %

Test set-up and procedure

The test object was connected to a signal analyser measuring peak and RMS output power in CDF mode. A resolution bandwidth of 50 MHz was used.

Measurement equipment	SP number
R&S FSQ 40	504 143
RF attenuator	900 691
Testo 635, temperature and humidity meter	504 203

Measurement uncertainty: 1.1 dB

Appendix 2

Results

Configuration: RDI Cable 200 m

MIMO mode, single carrier

Rated output power level at RF connector 1x 17 dBm.

Carrier BW [MHz]	Symbolic name	[RMS dBm/ PAR dB]		
		Port RF A	Port RF B	Total power ¹⁾
5	T	16.49/ 7.67	17.84/ 7.74	20.24
10	T	16.75/ 7.67	18.73/ 7.72	20.86
15	T	17.06/ 7.76	19.37/ 7.86	21.38
20	T	17.29/ 7.81	18.95/ 7.79	21.21

MIMO mode, multi carrier

Rated output power level at RF connector 2x 14 dBm.

Carrier BW [MHz]	Symbolic name	[RMS dBm/ PAR dB]		
		Port RF A	Port RF B	Total power ¹⁾
5	B2-5	14.90/ 7.76	15.49/ 7.81	18.22
5	M2-5	16.41/ 7.72	16.94/ 7.74	19.69
5	T2-5	16.73/ 7.74	18.14/ 7.79	20.50
10	T2-10	17.19/ 7.81	18.27/ 7.88	20.77
15	T2-15	16.84/ 7.98	18.00/ 8.08	20.47
20	T2-20	16.46/ 8.00	17.55/ 8.13	20.05

¹⁾: Summed output power according to FCC KDB662911 D01 Multiple transmitter output v02r01.

Note: The PAR value is the 0.1 % Peak to Average Ratio.

Appendix 2

Configuration: RDI Cable 92 m

MIMO mode, single carrier

Rated output power level at RF connector 1x 17 dBm.

Carrier BW [MHz]	Symbolic name	[RMS dBm/ PAR dB]		
		Port RF A	Port RF B	Total power ¹⁾
5	M	15.91/ 7.69	17.47/ 7.72	19.77
10	T	16.31/ 7.64	18.14/ 7.72	20.33
15	T	15.92/ 7.74	18.54/ 7.79	20.43
20	T	16.24/ 7.79	18.73/ 7.86	20.67

MIMO mode, multi carrier

Rated output power level at RF connector 2x 14 dBm.

Carrier BW [MHz]	Symbolic name	[RMS dBm/ PAR dB]		
		Port RF A	Port RF B	Total power ¹⁾
5	B2-5	15.36/ 7.79	16.25/ 7.76	18.84
5	M2-5	16.19/ 7.72	17.47/ 7.72	19.89
5	T2-5	15.52/ 7.72	18.05/ 7.76	19.97

¹⁾: Summed output power according to FCC KDB662911 D01 Multiple transmitter output v02r01.

Note: The PAR value is the 0.1 % Peak to Average Ratio.

Appendix 2

Configuration: RDI Cable 20 m

MIMO mode, single carrier

Rated output power level at RF connector 1x 17 dBm.

Carrier BW [MHz]	Symbolic name	[RMS dBm/ PAR dB]		
		Port RF A	Port RF B	Total power ¹⁾
5	M	16.47/ 7.69	16.82/ 7.78	19.66
10	M	16.35/ 7.67	17.03/ 7.69	19.72
15	T	15.56/ 7.76	17.04/ 7.79	19.37
20	T	15.85/ 7.81	17.27/ 7.84	19.63

MIMO mode, multi carrier

Rated output power level at RF connector 2x 14 dBm.

Carrier BW [MHz]	Symbolic name	[RMS dBm/ PAR dB]		
		Port RF A	Port RF B	Total power ¹⁾
5	B2-5	16.21/ 7.76	16.53/ 7.74	19.38
5	M2-5	16.66/ 7.72	17.44/ 7.72	20.08
5	T2-5	15.06/ 7.72	16.76/ 7.79	19.00

¹⁾: Summed output power according to FCC KDB662911 D01 Multiple transmitter output v02r01.

Note: The PAR value is the 0.1 % Peak to Average Ratio.

Appendix 2

Configuration: RDI Cable 200 m

MIMO mode, single carrier

Measured output power per 1 MHz.

Carrier BW [MHz]	Symbolic name	[RMS dBm]		Total power ¹⁾ [RMS dBm]
		Port RF A	Port RF B	
5	T	10.63	12.91	15.91
10	T	8.37	10.78	13.78
15	T	6.68	9.21	12.21
20	T	5.56	7.51	10.51

Configuration: RDI Cable 92 m

MIMO mode, single carrier

Measured output power per 1 MHz.

Carrier BW [MHz]	Symbolic name	[RMS dBm]		Total power ¹⁾ [RMS dBm]
		Port RF A	Port RF B	
5	M	9.77	11.73	14.73
10	T	7.42	9.71	12.71
15	T	5.82	7.98	10.98
20	T	4.72	6.67	9.67

¹⁾: Measured according to FCC KDB662911 D01 Multiple Transmitter Output v02r01. Method E), 2), c). "Measure and add $10 \log(N_{Ant})$ ".

Appendix 2

Configuration: RDI Cable 20 m

MIMO mode, single carrier

Measured output power per 1 MHz.

Carrier BW [MHz]	Symbolic name	[RMS dBm]		Total power ¹⁾ [RMS dBm]
		Port RF A	Port RF B	
5	M	10.41	10.89	13.89
10	M	7.85	8.24	11.24
15	T	5.63	7.00	10.00
20	T	4.98	6.28	9.28

¹⁾: Measured according to FCC KDB662911 D01 Multiple Transmitter Output v02r01. Method E), 2), c). “Measure and add 10 log(N_{Ant})”.

Limits

§24.232 The maximum output power may not exceed 3280 W/MHz (EIRP).
The Peak to Average Ratio (PAR) may not exceed 13 dB.

RSS-133 Base station transmitters operating in the band 1930-1995 MHz shall not have output power exceeding 100 watts. When the transmitter power is measured in terms of average value, the peak-to-average ratio(PAR) of the power shall not exceed 13 dB

There is no EIRP limit specified for base station equipment in the RSS-133.

EIRP compliance is addressed at the time of licensing, as required by the responsible IC Bureau. Licensee’s are required to take into account the antenna gain to get the maximum usable power settings to prevent the radiated output power to exceed the EIRP limits specified in SRSP-510

Complies?	Yes
-----------	-----

Appendix 3

RF power output measurements according to CFR 47 §24.232 / IC RSS-133 6.4, radiated

Date	Temperature	Humidity
2015-02-03	22 °C ± 3°C	18 % ± 5 %
2015-02-04	22 °C ± 3°C	20 % ± 5 %

Test set-up and procedure

The measurements were performed according to ANSI/TIA-603-C.

The test was performed with continuous transmission.

The test of radiated emission was performed in a semi anechoic chamber. The measurements were performed with both horizontal and vertical polarizations of the antenna. The antenna distance was 3.0 m.

The fundamental was scanned with PEAK-detector with the antenna height was varied between 1-4 m and the turntable was rotated between 0-360 degrees for maximum response. The carrier power was measured with RMS- detector activated with a RBW of 1 MHz. The output power was verified with the substitution method according to ANSI/TIA-603-C. The antenna distance during the measurements was 3.0 m.

Measurement equipment

Measurement equipment	SP number
Semi anechoic chamber	503 881
R&S ESU 26	901 553
EMC 32 ver. 9.15.0	503 899
EMCO Horn Antenna 3115	502 175
EMCO Horn Antenna 3115	902 212
Coaxial cable	503 936
R&S SMB 100A	900 120
Attenuator	BX41643
Testo 635 temperature and humidity meter	504 188

Measurement uncertainty:

3.1 dB

Appendix 3

The test set-up during the effective radiated output power measurements is shown in the picture below, side position.



The test set-up during the effective radiated output power measurements is shown in the picture below, upright position.



Appendix 3

Results

Configuration: RDI Cable 200 m

Upright position

Bandwidth configuration (MHz)	Symbolic name B		Symbolic name M		Symbolic name T	
	Vertical/Horizontal RMS power (EIRP)		Vertical/Horizontal RMS power (EIRP)		Vertical/Horizontal RMS power (EIRP)	
	dBm/ MHz	mW/ MHz	dBm/ MHz	mW/ MHz	dBm/ MHz	mW/ MHz
5	9.8/ 10.7	9.5/ 11.7	12.3/ 12.3	17.0/ 17.0	12.3/ 12.8	17.0/ 19.1
10	-	-	9.4/ 9.9	8.7/ 9.8	-	-
15	-	-	7.9/ 8.6	6.2/ 7.2	-	-
20	-	-	7.0/ 7.5	5.0/ 5.6	-	-

Side position

Bandwidth configuration (MHz)	Symbolic name B		Symbolic name M		Symbolic name T	
	Vertical/Horizontal RMS power (EIRP)		Vertical/Horizontal RMS power (EIRP)		Vertical/Horizontal RMS power (EIRP)	
	dBm/ MHz	mW/ MHz	dBm/ MHz	mW/ MHz	dBm/ MHz	mW/ MHz
5	8.3/ 11.1	6.8/ 12.9	11.0/ 13.6	12.6/ 22.9	11.3/ 14.2	13.5/ 26.3
10	-	-	8.5/ 10.4	7.1/ 11.0	-	-
15			7.2/ 9.6	5.3/ 9.1		
20			6.0/ 8.2	4.0/ 6.6		



Appendix 3

Limits

§24.232 The maximum output power may not exceed 3280 W/MHz (EIRP).
The Peak to Average Ratio (PAR) may not exceed 13 dB.

RSS-133 Base station transmitters operating in the band 1930-1995 MHz shall not have output power exceeding 100 watts. When the transmitter power is measured in terms of average value, the peak-to-average ratio(PAR) of the power shall not exceed 13 dB

There is no EIRP limit specified for base station equipment in the RSS-133.

EIRP compliance is addressed at the time of licensing, as required by the responsible IC Bureau. Licensee's are required to take into account the antenna gain to get the maximum usable power settings to prevent the radiated output power to exceed the EIRP limits specified in SRSP-510

Complies?	Yes
-----------	-----

Appendix 4

Occupied bandwidth measurements according to 47 CFR 2.1049 / RSS-Gen 6.6

Date	Temperature	Humidity
2015-01-20	22 °C ± 3 °C	20 % ± 5 %
2015-01-21	22 °C ± 3 °C	20 % ± 5 %
2015-01-22	21 °C ± 3 °C	20 % ± 5 %

Test set-up and procedure

The measurements were made according to in FCC: KDB: 971168 D01 Power Meas Licens, v02r02 and IC: RSS-Gen section 6.6. The output was connected to a signal analyzer with the Peak detector activated and max hold. The signal analyser was connected to an external 10 MHz reference standard during the measurements.

Measurement equipment	SP number
R&S FSQ 40	504 143
RF attenuator	900 691
Testo 635, temperature and humidity meter	504 203

Measurement uncertainty: 3.7 dB

Appendix 4

Results

Configuration: RDI Cable 92 m

MIMO mode, single carrier

Diagram	BW configuration	Symbolic name	Tested Port	Occupied BW (99%) [MHz]
1	5 MHz	B	RF B	4.48
2	5 MHz	M	RF B	4.48
3	5 MHz	T	RF B	4.48

Configuration: RDI Cable 200 m

MIMO mode, single carrier

Diagram	BW configuration	Symbolic name	Tested Port	Occupied BW (99%) [MHz]
4	5 MHz	B	RF B	4.48
5	5 MHz	M	RF B	4.48
6	5 MHz	T	RF A	4.48
7	5 MHz	T	RF B	4.48
8	10 MHz	M	RF B	8.91
9	15 MHz	M	RF B	13.36
10	20 MHz	M	RF B	17.78

Configuration: RDI Cable 20 m

MIMO mode, single carrier

Diagram	BW configuration	Symbolic name	Tested Port	Occupied BW (99%) [MHz]
11	5 MHz	B	RF B	4.47
12	5 MHz	M	RF B	4.49
13	5 MHz	T	RF B	4.47

Appendix 4

Diagram 1:

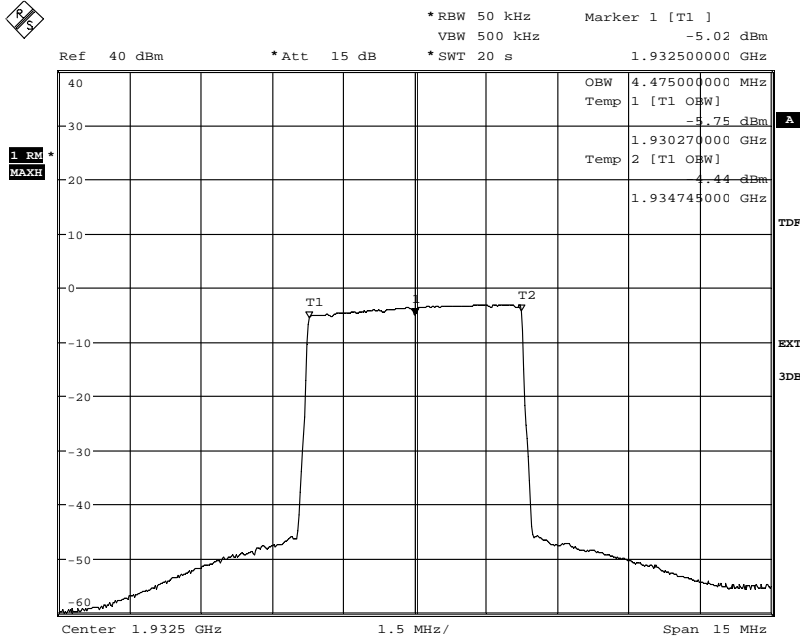

Date: 22.JAN.2015 10:49:49

Diagram 2:

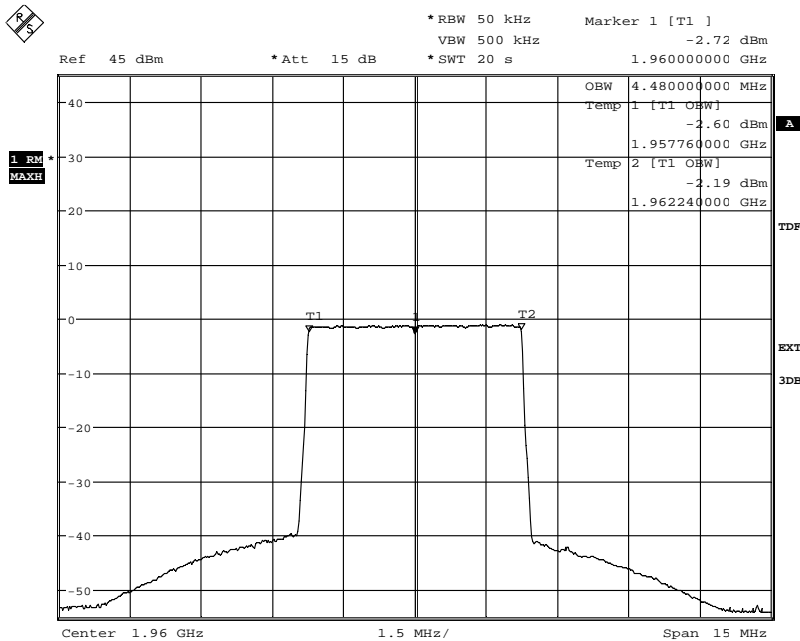

Date: 22.JAN.2015 08:20:41

Appendix 4

Diagram 3:

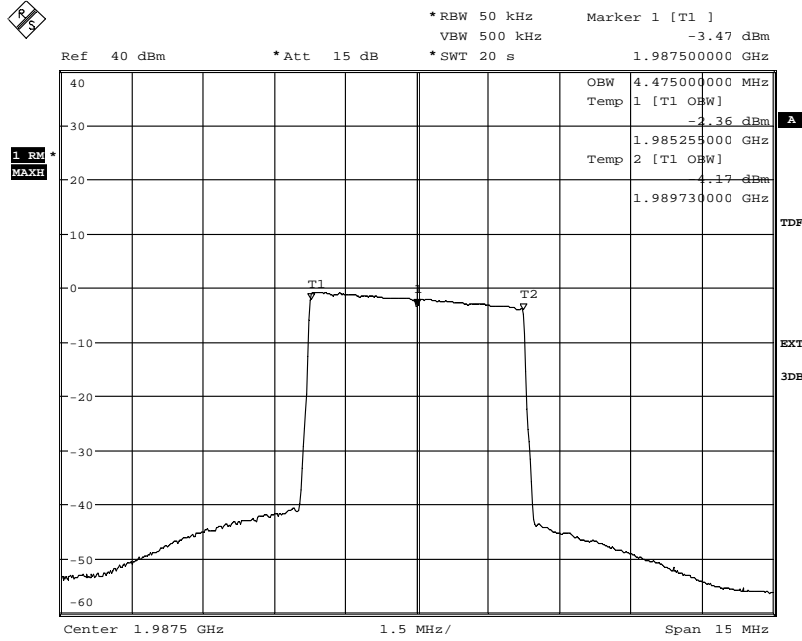

Date: 22.JAN.2015 10:32:26

Diagram 4:

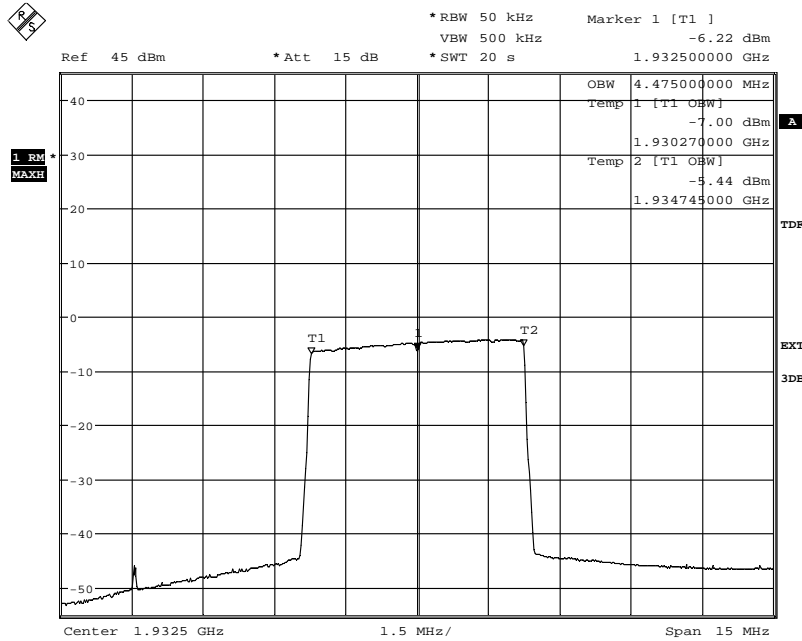

Date: 21.JAN.2015 10:12:06

Appendix 4

Diagram 5:

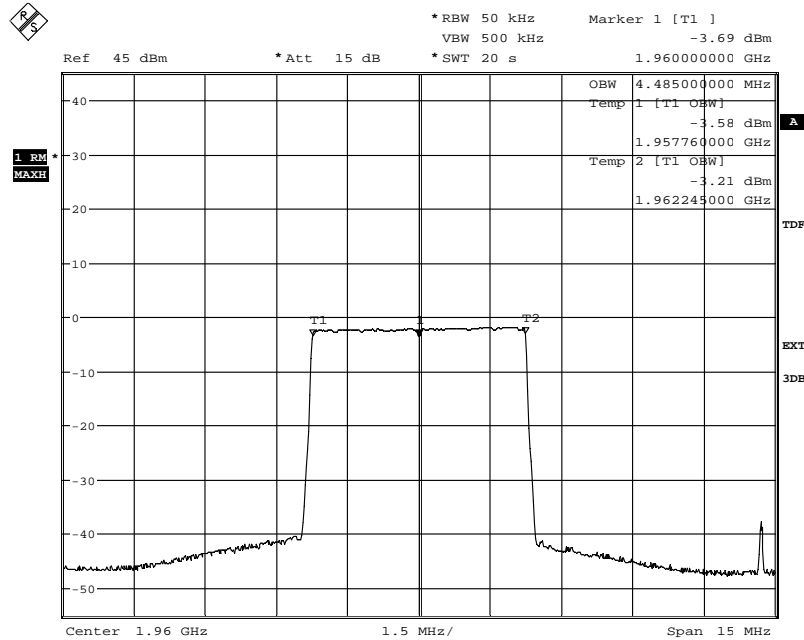

Date: 21.JAN.2015 08:39:44

Diagram 6:

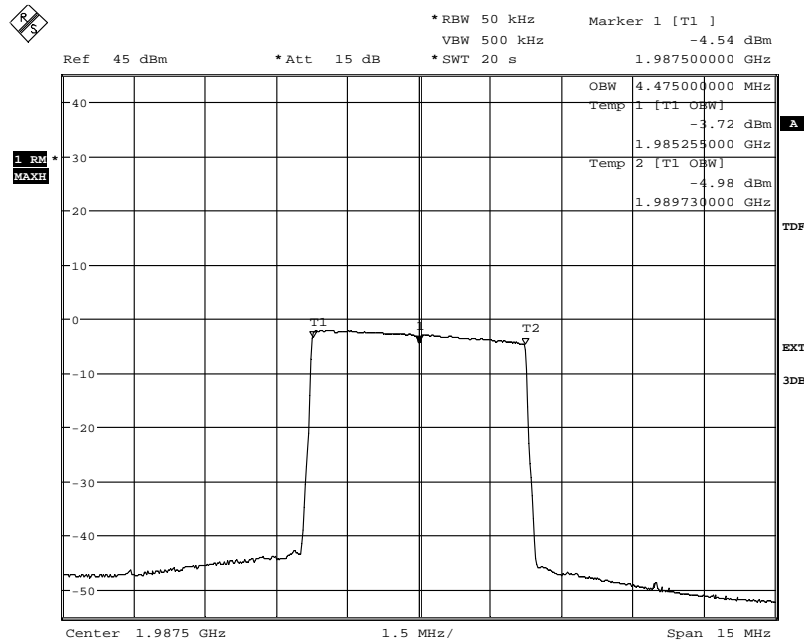

Date: 21.JAN.2015 10:45:28

Appendix 4

Diagram 7:

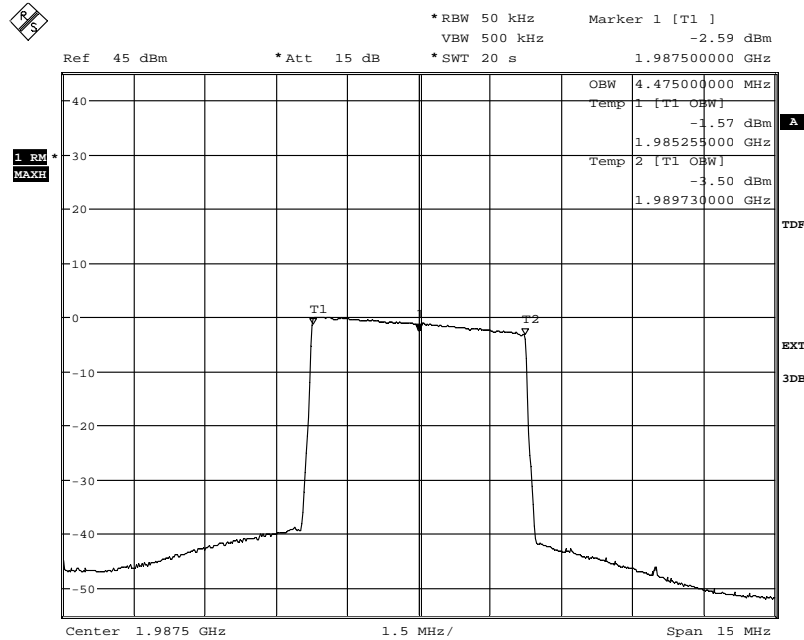

Date: 20.JAN.2015 14:55:39

Diagram 8:

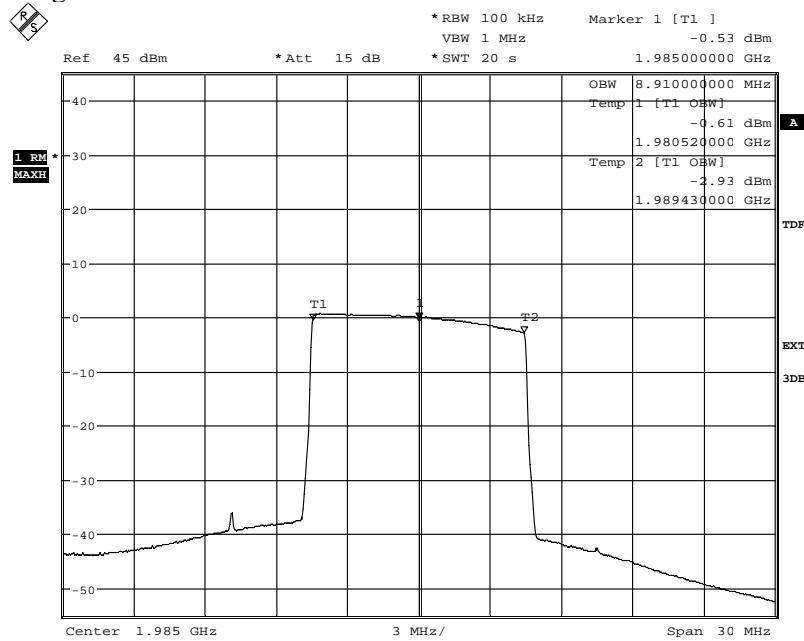

Date: 20.JAN.2015 08:41:40

Appendix 4

Diagram 9:

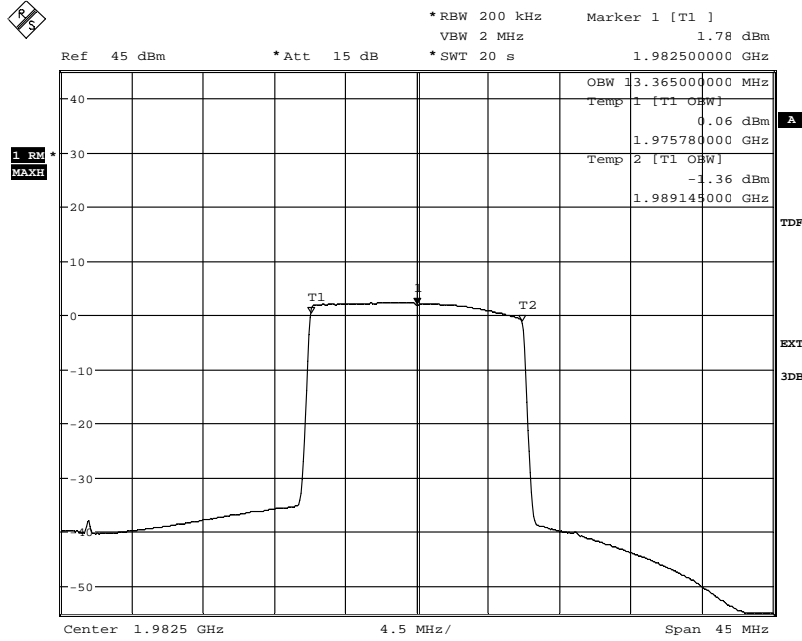

Date: 20.JAN.2015 12:09:44

Diagram 10:

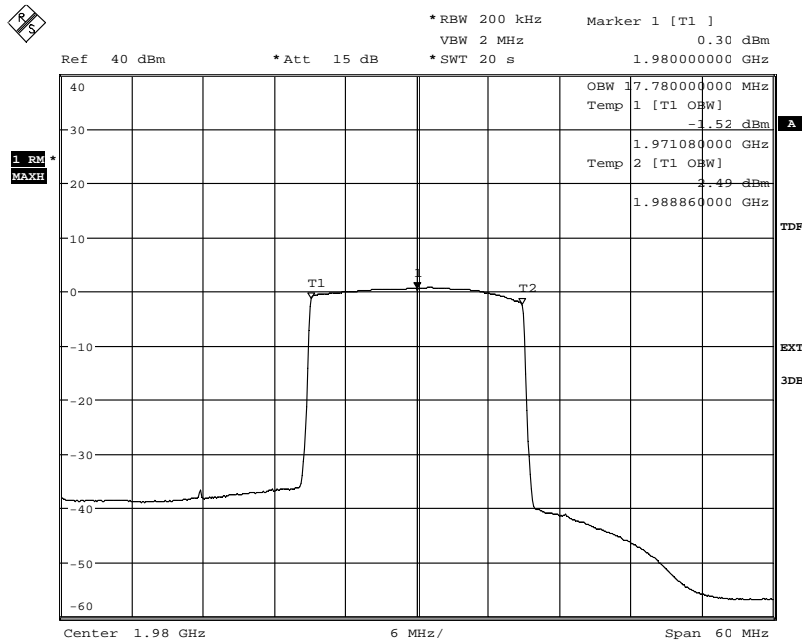

Date: 20.JAN.2015 11:33:16

Appendix 4

Diagram 11:

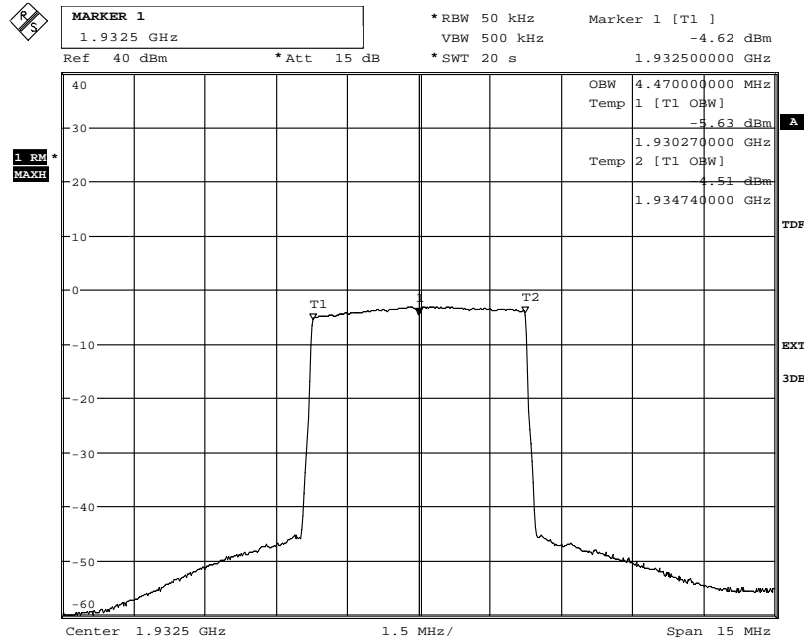

Date: 22.JAN.2015 14:47:49

Diagram 12:

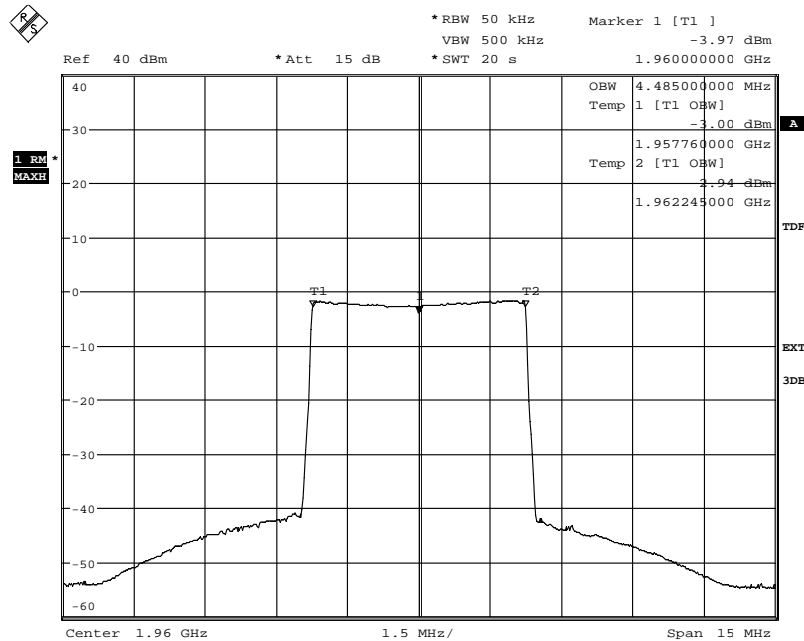

Date: 22.JAN.2015 14:44:57

Appendix 4

Diagram 13:

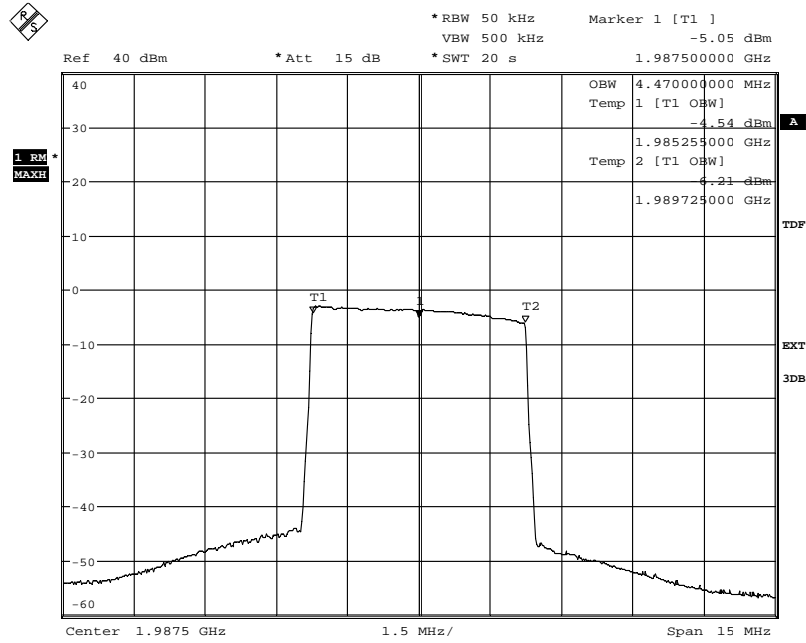

Date: 22.JAN.2015 14:39:55

Appendix 5

Band edge measurements according to CFR 47 §24.238 / IC RSS-133 6.5

Date	Temperature	Humidity
2015-01-20	22 °C ± 3 °C	20 % ± 5 %
2015-01-21	22 °C ± 3 °C	20 % ± 5 %
2015-01-22	21 °C ± 3 °C	20 % ± 5 %
2015-01-23	22 °C ± 3 °C	18 % ± 5 %

Test set-up and procedure

The measurements were made per definition in §24.238. The test object was connected to a spectrum analyser with the RMS detector activated. The spectrum analyzer was connected to an external 10 MHz reference standard during the measurements.

Beyond the 1st MHz off the band edges the limit was adjusted to compensate for reduced measurement bandwidths pursuant to the FCC rules, specifying a RBW of at least 1% of the fundamental emission bandwidth up to 1 MHz away from the band edges and a RBW of 1 MHz for measurements of emissions more than 1 MHz away from the band edges. A resolution bandwidth of 200 kHz was used 1 MHz to 6 MHz away from the band edges, to compensate for the reduced resolution bandwidth the limit was adjusted by 7 dB to -20 dBm. Before comparing the results to the limit, 3 dB [10 log (2)] should be added according to method E), 3), a), (iii) Measure and add 10 log(N_{ANT})” of FCC KDB662911 D01 Multiple Transmitter Output v02r01.

Measurement equipment	SP number
R&S FSQ 43	504 143
RF attenuator	900 691
Testo 635, temperature and humidity meter	504 203

Measurement uncertainty: 3.7 dB

Appendix 5

Results

Configuration: RDI Cable 92 m

MIMO mode, single carrier

Diagram	BW configuration	Symbolic name	Tested Port
1 a-c	5 MHz	B	RF B
2 a-c	5 MHz	T	RF B

MIMO mode, multi carrier

Diagram	BW configuration	Symbolic name	Tested Port
3 a-c	5 MHz	B2-5	RF B
4 a-c	5 MHz	T2-5	RF B

Configuration: RDI Cable 200 m

MIMO mode, single carrier

Diagram	BW configuration	Symbolic name	Tested Port
5 a-c	5 MHz	B	RF A
6 a-c	5 MHz	B	RF B
7 a-c	10 MHz	B	RF B
8 a-c	15 MHz	B	RF B
9 a-c	20 MHz	B	RF B
10 a-c	5 MHz	T	RF A
11 a-c	5 MHz	T	RF B
12 a-c	10 MHz	T	RF B
13 a-c	15 MHz	T	RF B
14 a-c	20 MHz	T	RF B

MIMO mode, multi carrier

Diagram	BW configuration	Symbolic name	Tested Port
15 a-c	5 MHz	B2-5	RF B
16 a-c	5 MHz	T2-5	RF B

Configuration: RDI Cable 20 m

MIMO mode, single carrier

Diagram	BW configuration	Tested frequency	Tested Port
17 a-c	5 MHz	B	RF B
18 a-c	5 MHz	T	RF B

Limits

CFR 47 §24.238 and RSS-133 6.5

Outside a licensee's frequency band(s) of operation the power of any emission shall be attenuated below the transmitter power (P) by at least $43 + 10 \log (P)$ dB, resulting in a limit of -13 dBm.

Complies?	Yes
-----------	-----

Appendix 5

Diagram 1 a:

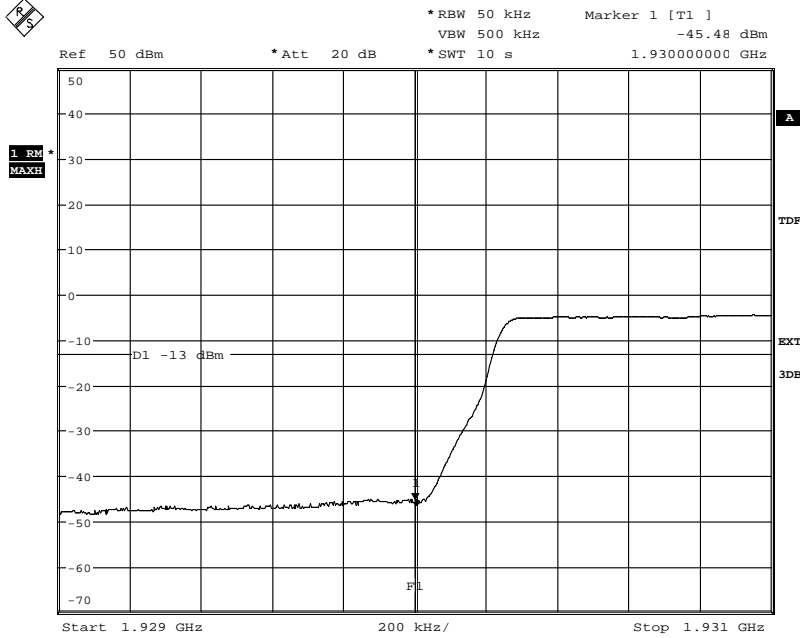

Date: 22.JAN.2015 10:45:21

Diagram 1 b:

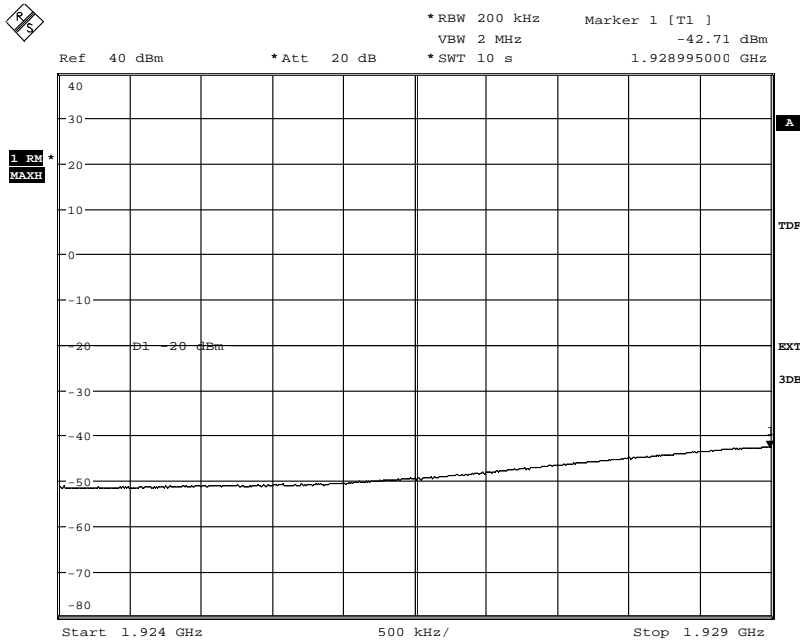

Date: 22.JAN.2015 10:46:38

Appendix 5

Diagram 1c:

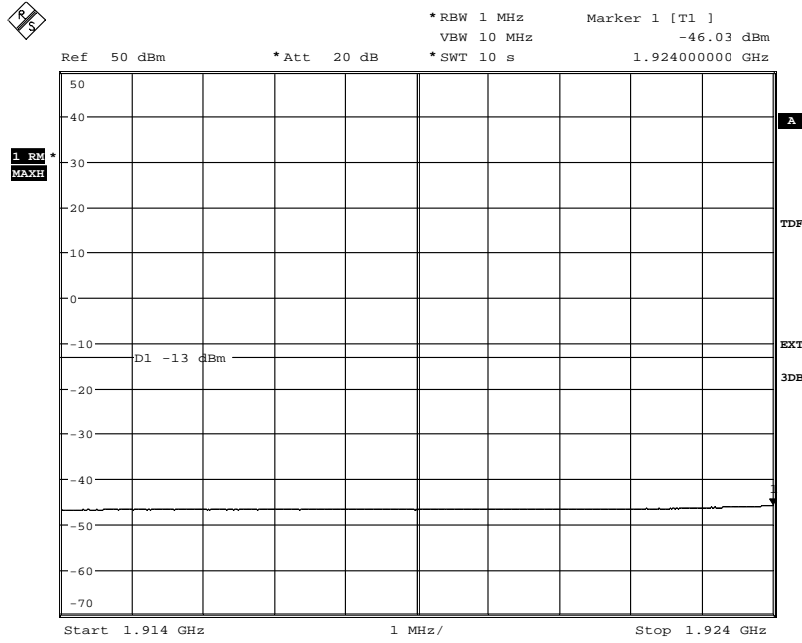

Date: 22.JAN.2015 10:47:34

Appendix 5

Diagram 2 a:

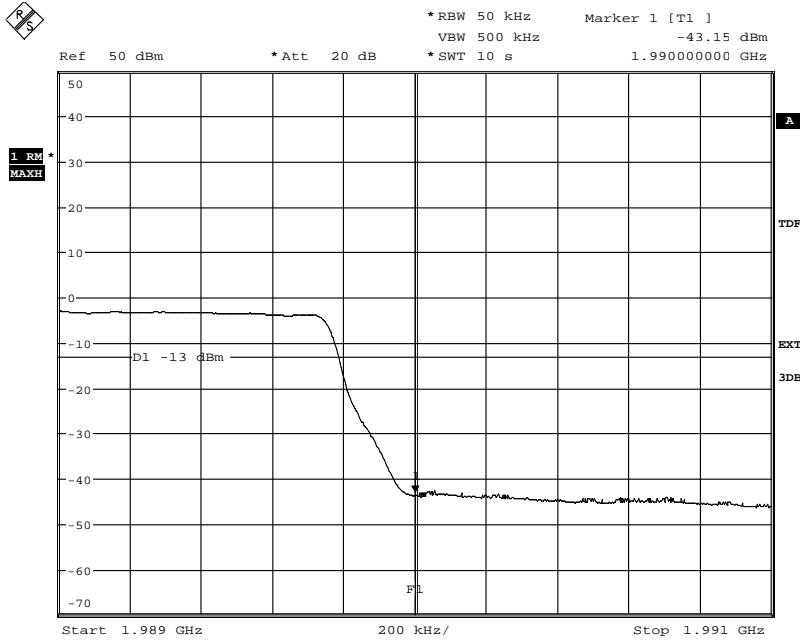

Date: 22.JAN.2015 10:28:14

Diagram 2 b:

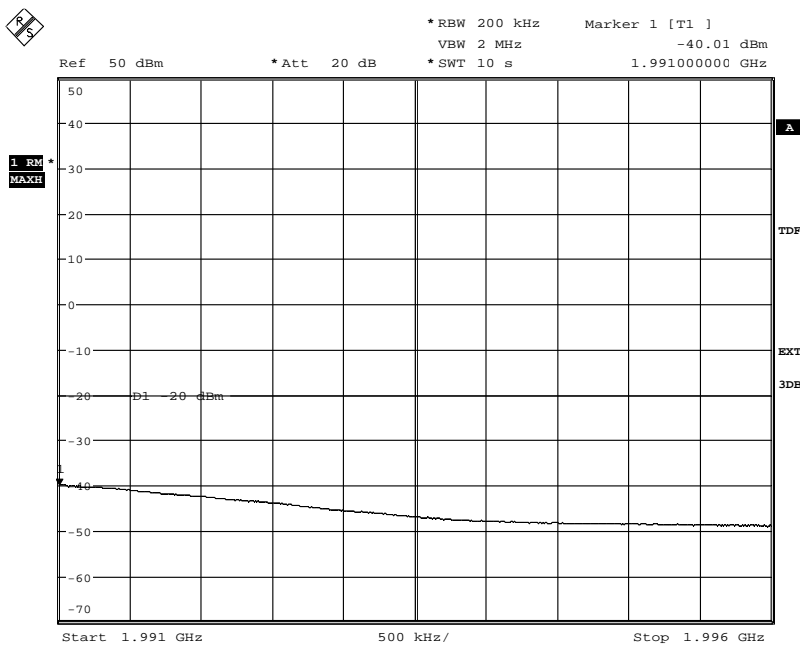

Date: 22.JAN.2015 10:29:06

Appendix 5

Diagram 2 c:

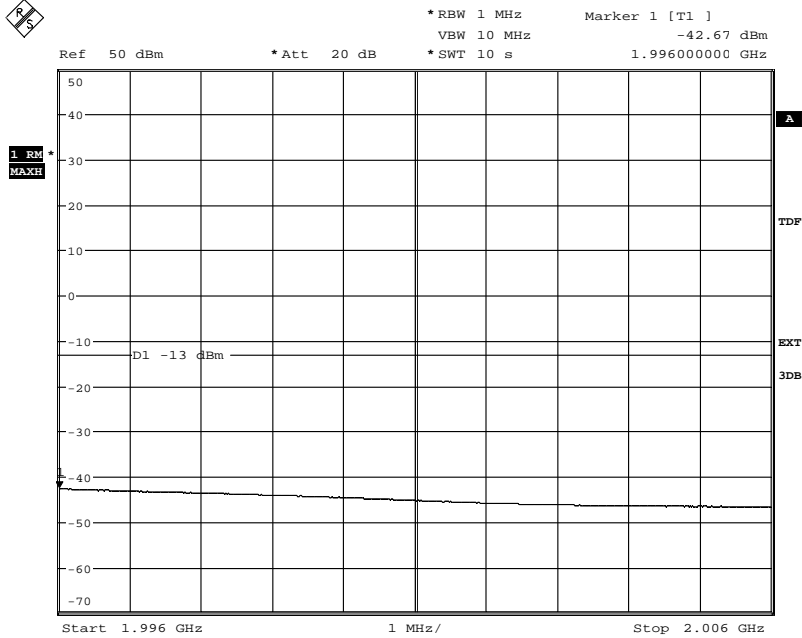

Date: 22.JAN.2015 10:29:49

Appendix 5

Diagram 3 a:

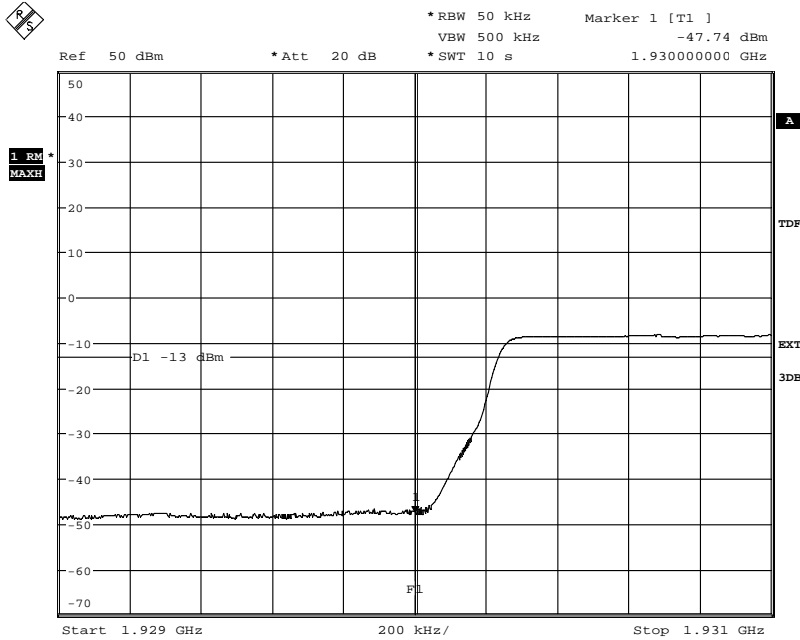

Date: 23.JAN.2015 13:58:30

Diagram 3 b:

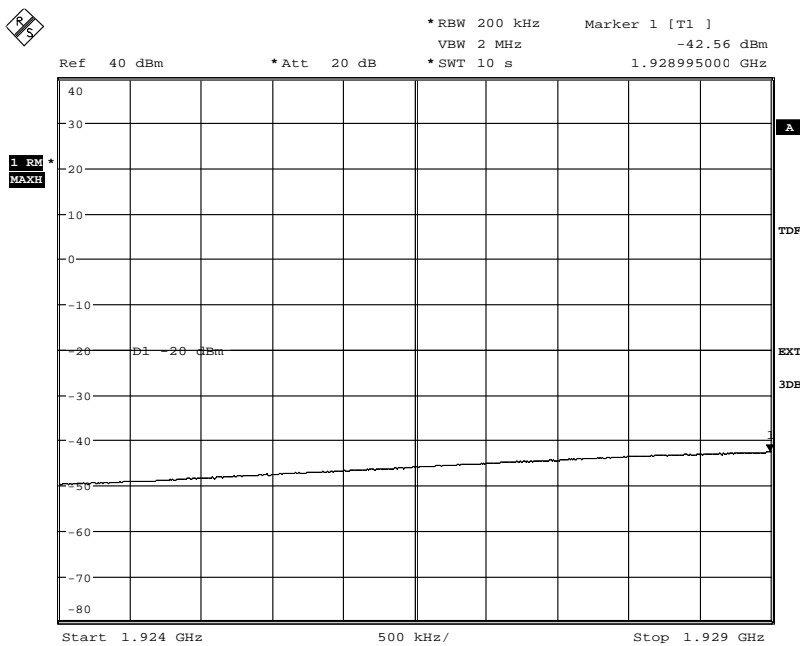

Date: 23.JAN.2015 14:00:05

Appendix 5

Diagram 3 c:

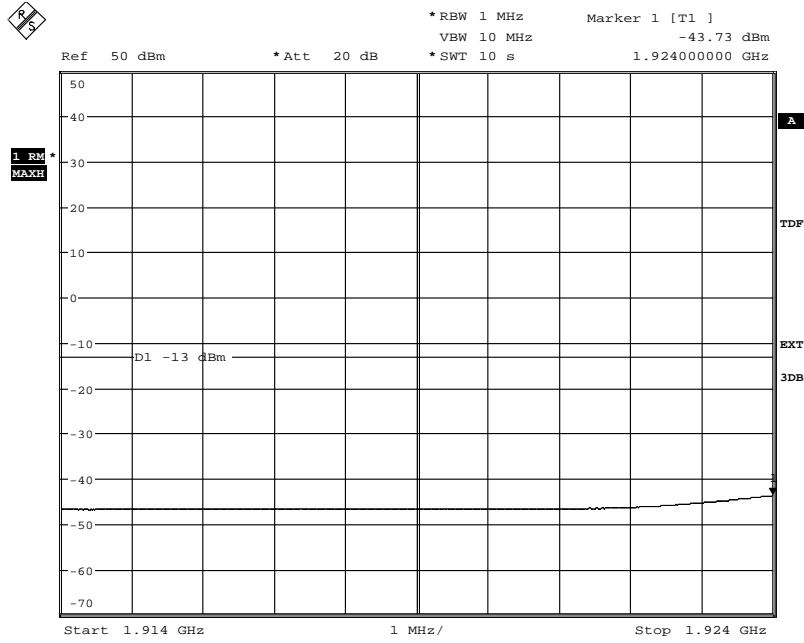

Date: 23.JAN.2015 14:01:41

Appendix 5

Diagram 4 a:

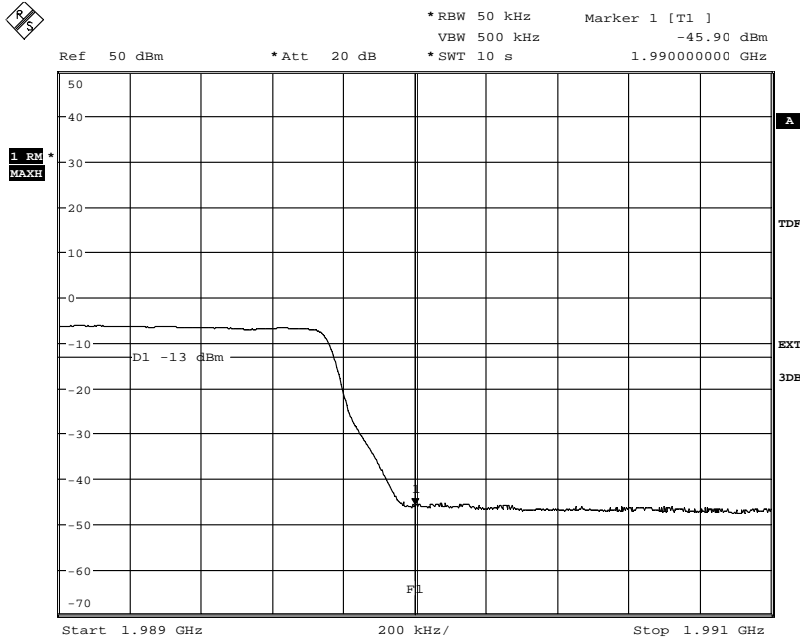

Date: 23.JAN.2015 14:09:56

Diagram 4 b:

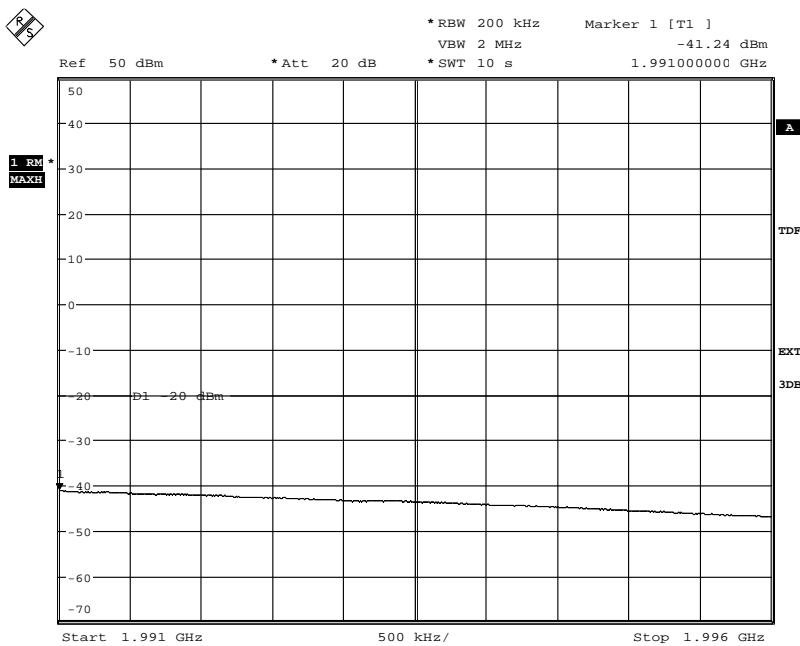

Date: 23.JAN.2015 14:11:24

Appendix 5

Diagram 4 c:

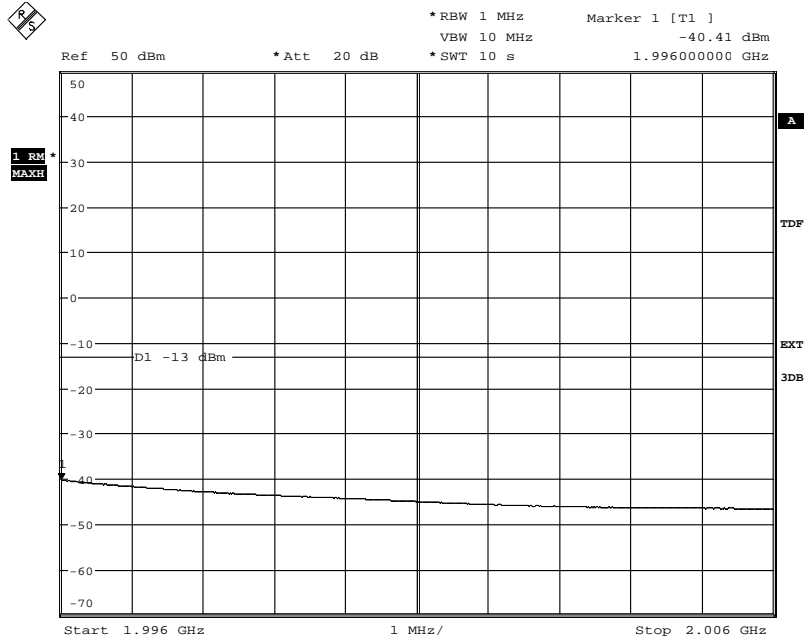

Date: 23.JAN.2015 14:13:21

Appendix 5

Diagram 5 a:

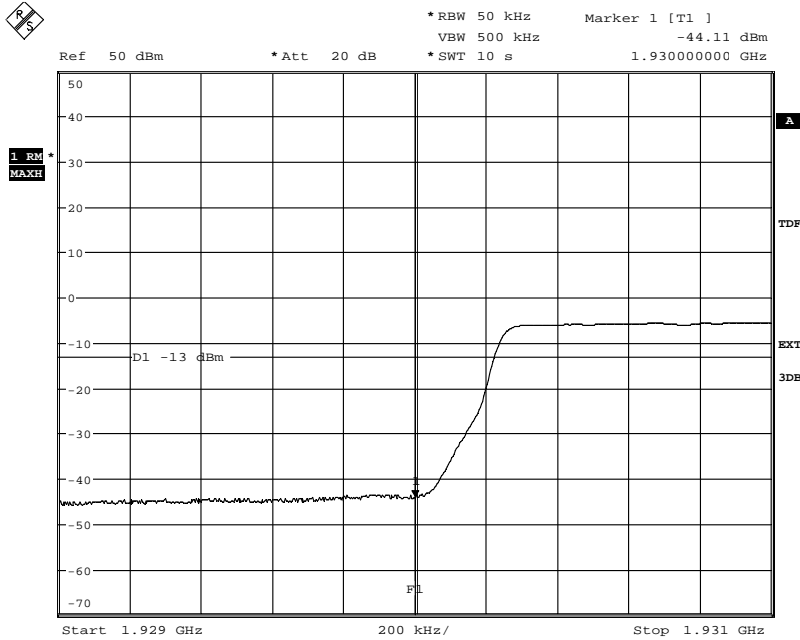

Date: 21.JAN.2015 11:25:33

Diagram 5 b:

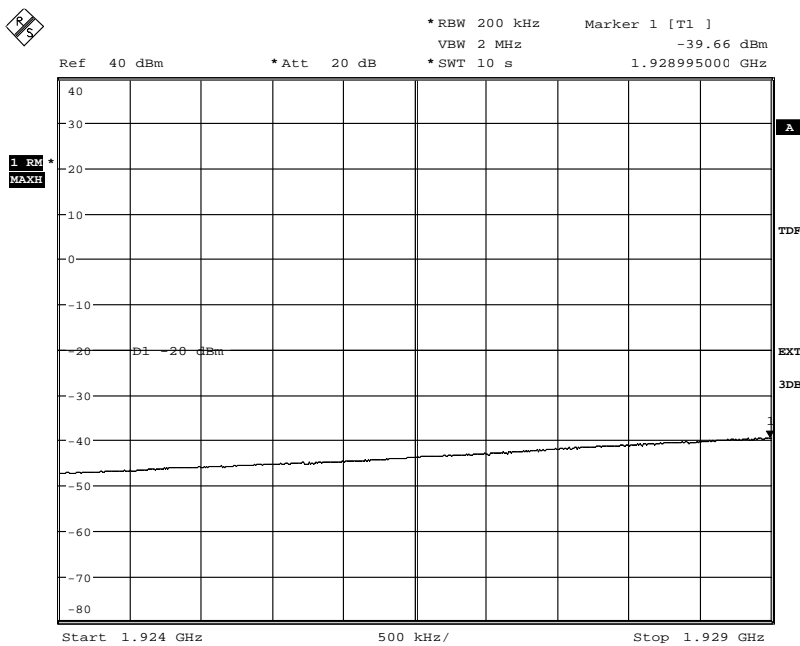

Date: 21.JAN.2015 11:27:18

Appendix 5

Diagram 5 c:

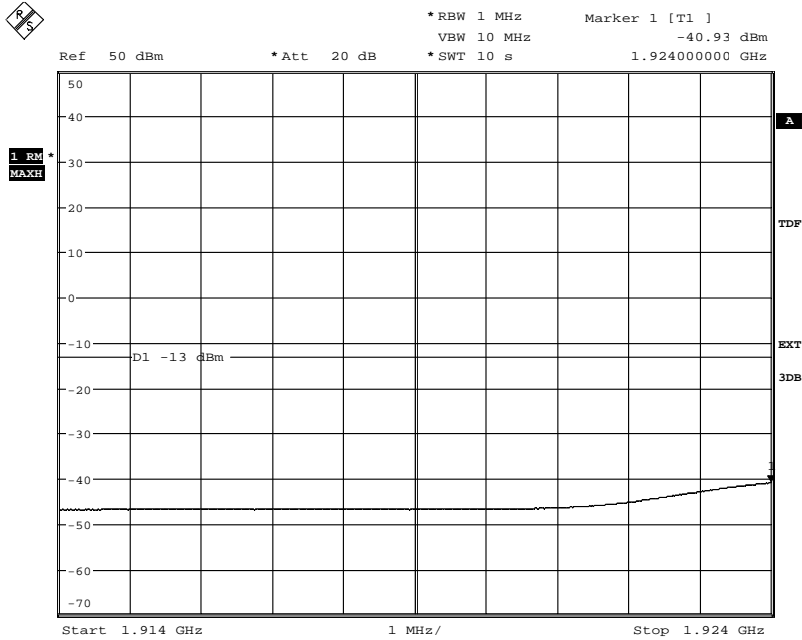

Date: 21.JAN.2015 11:28:30

Appendix 5

Diagram 6 a:

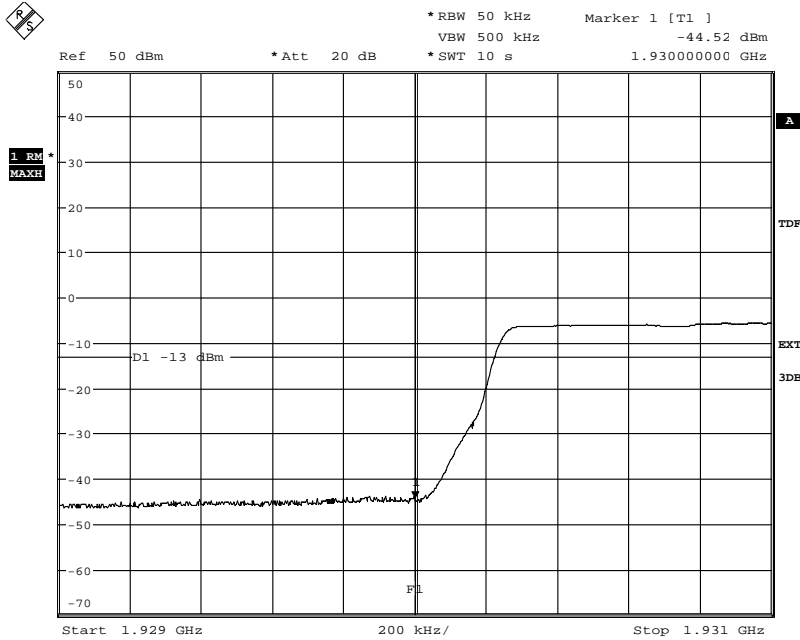

Date: 21.JAN.2015 10:07:51

Diagram 6 b:

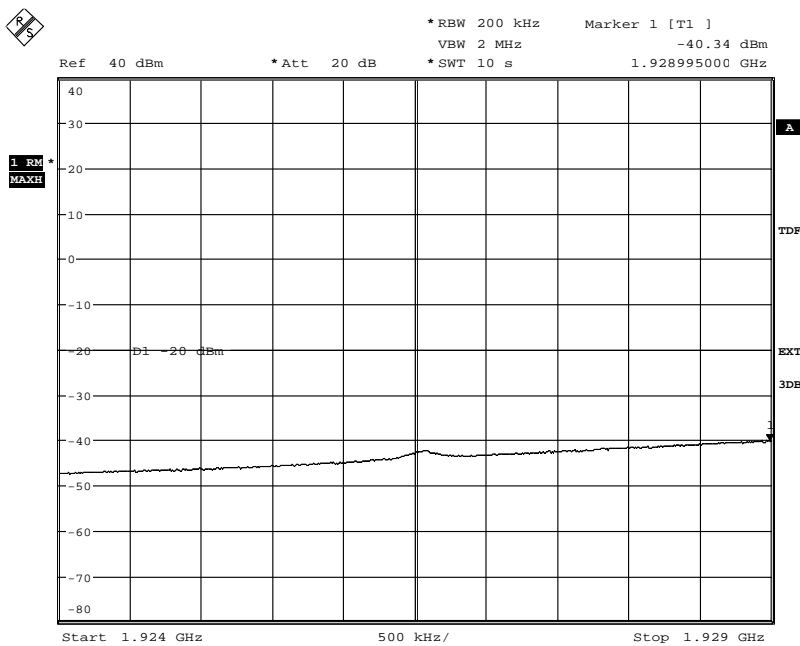

Date: 21.JAN.2015 10:06:45

Appendix 5

Diagram 6 c:

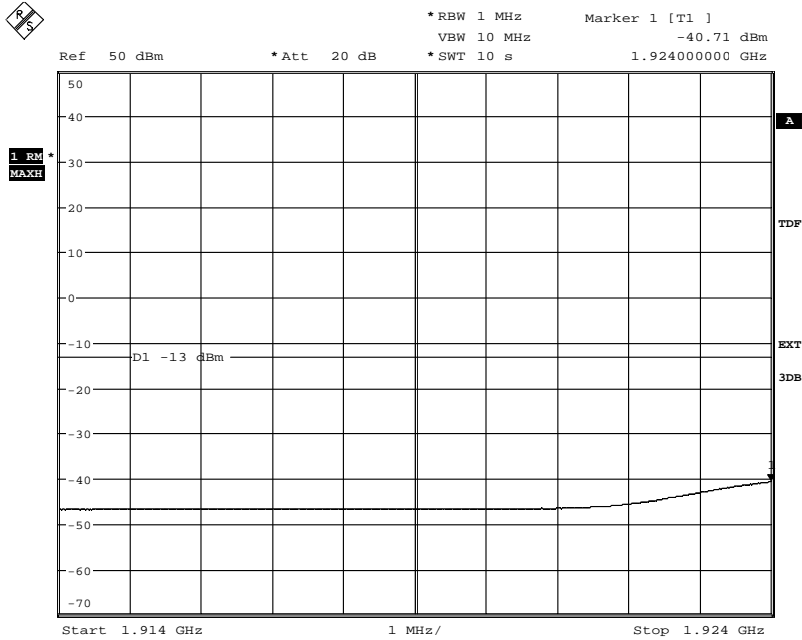

Date: 21.JAN.2015 10:05:41

Appendix 5

Diagram 7 a:

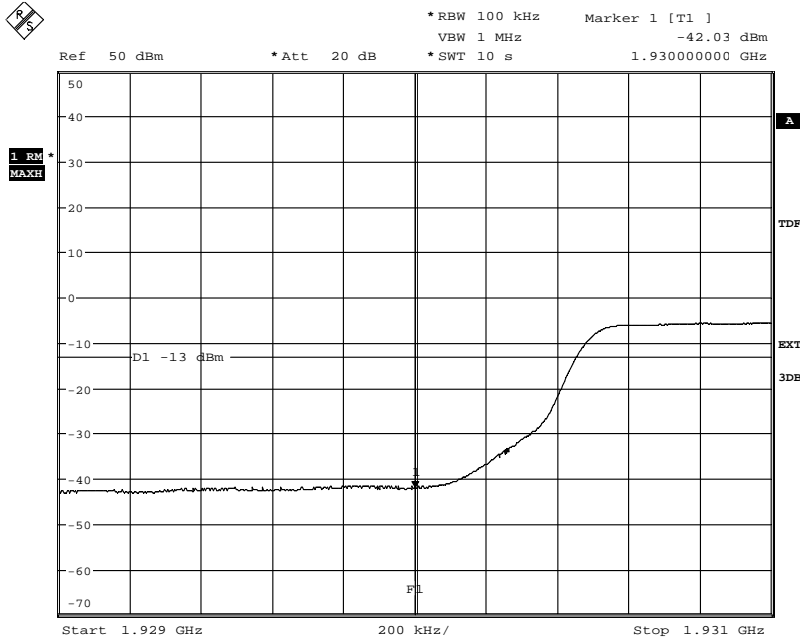

Date: 21.JAN.2015 10:00:27

Diagram 7 b:

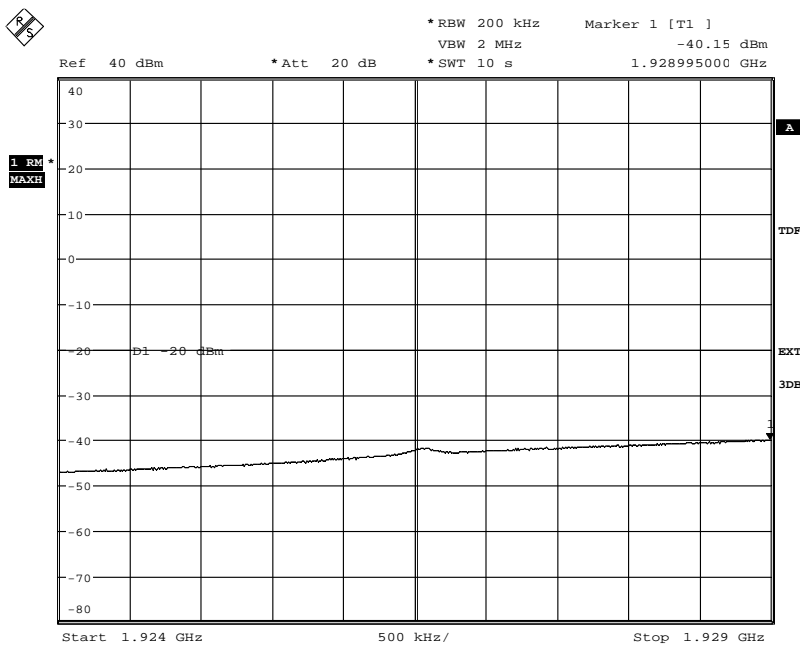

Date: 21.JAN.2015 10:01:29

Appendix 5

Diagram 7 c:

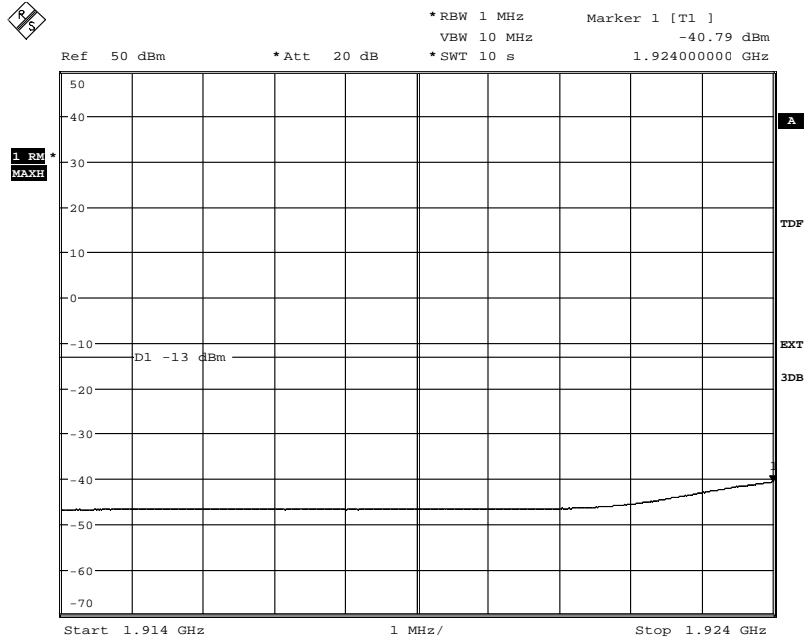

Date: 21.JAN.2015 10:02:36

Appendix 5

Diagram 8 a:

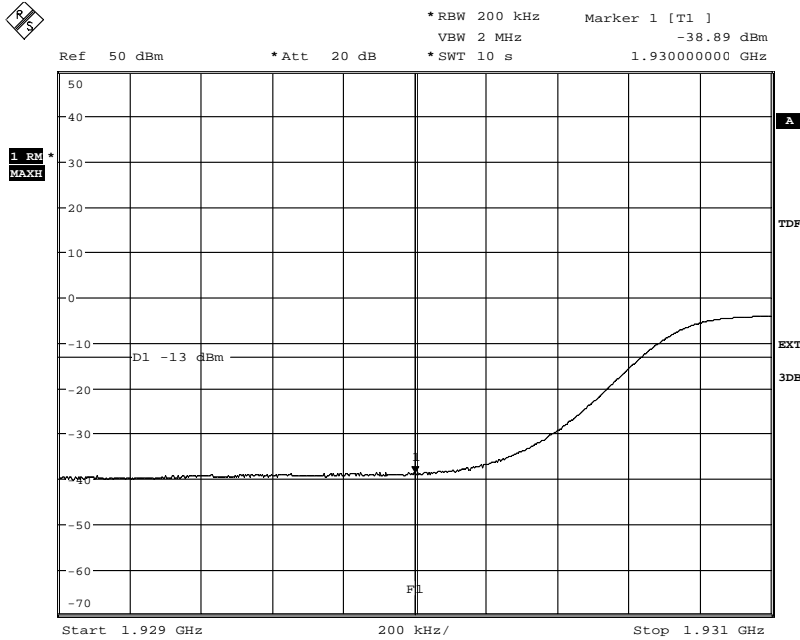

Date: 21.JAN.2015 09:58:19

Diagram 8 b:

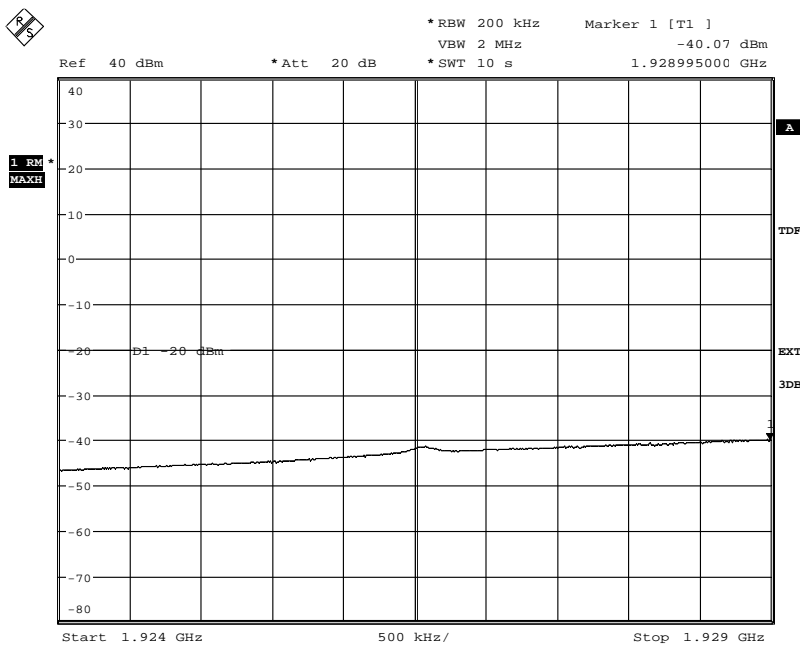

Date: 21.JAN.2015 09:56:28

Appendix 5

Diagram 8 c:

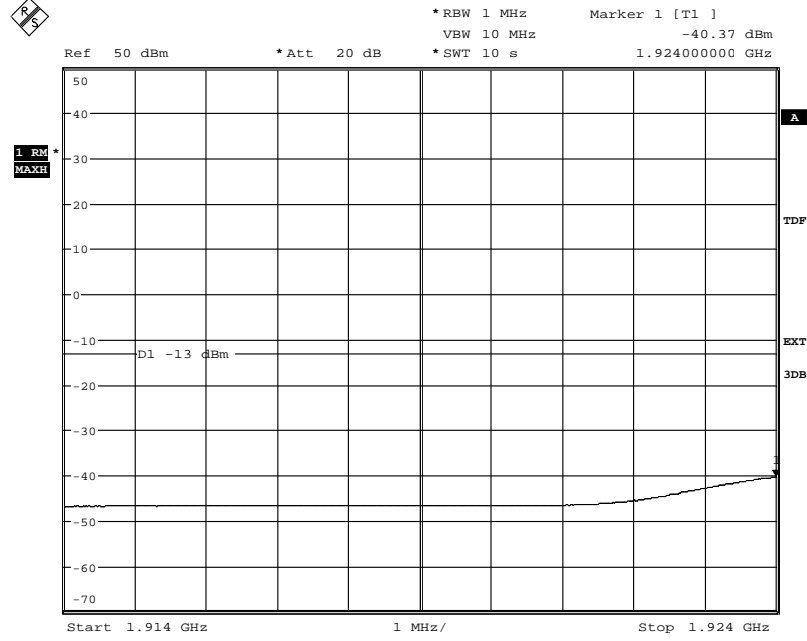

Date: 21.JAN.2015 09:55:33

Appendix 5

Diagram 9 a:

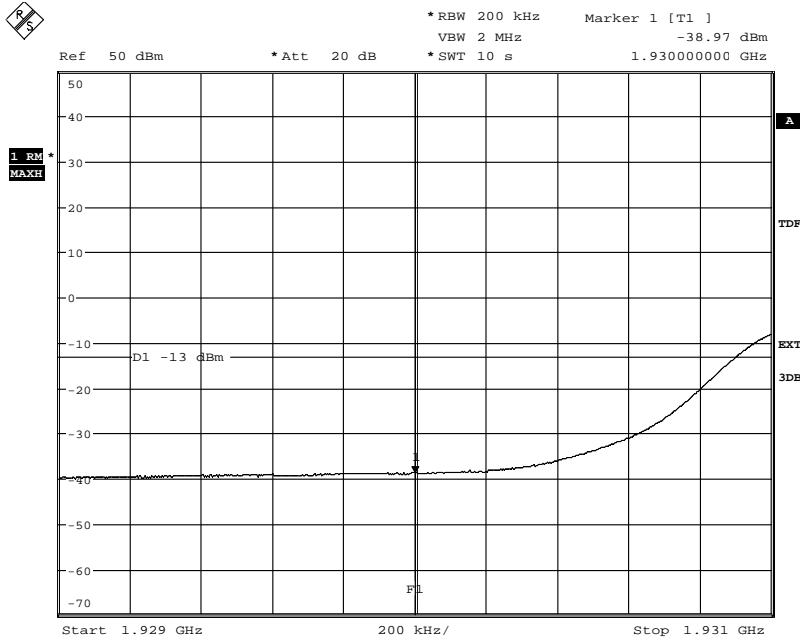

Date: 21.JAN.2015 09:51:26

Diagram 9 b:

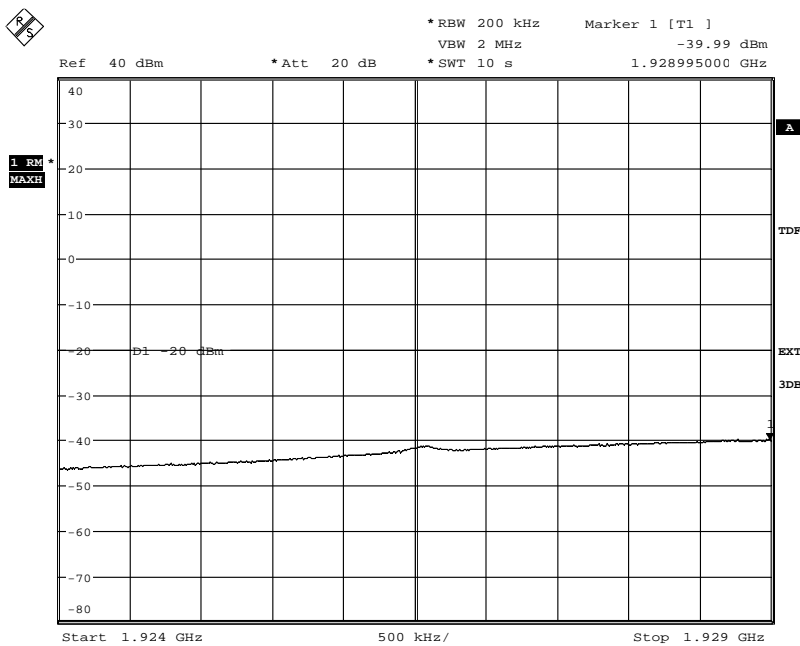

Date: 21.JAN.2015 09:52:35

Appendix 5

Diagram 9 c:

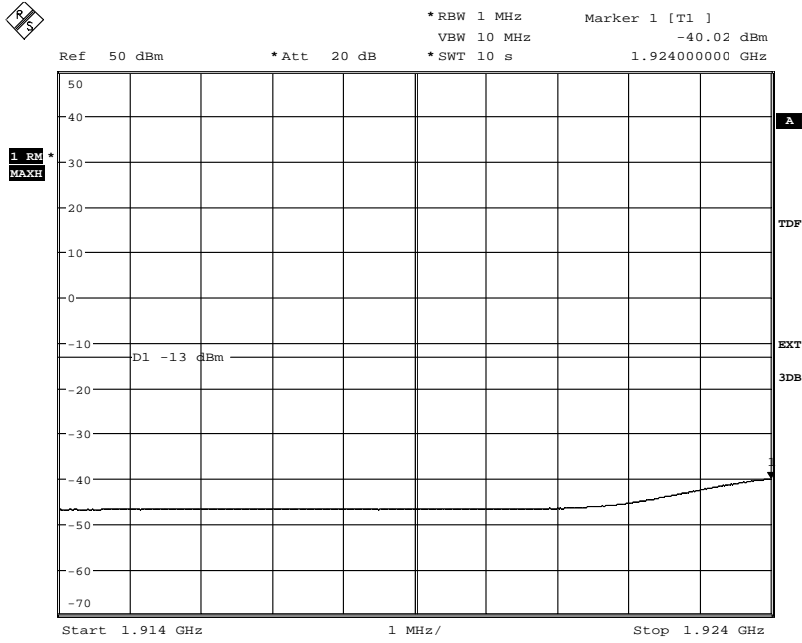

Date: 21.JAN.2015 09:53:33

Appendix 5

Diagram 10 a:

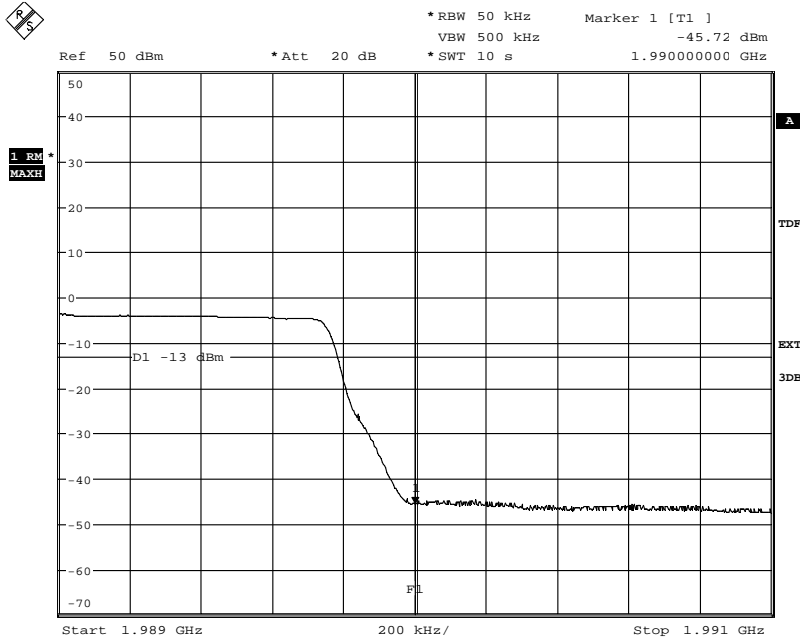

Date: 21.JAN.2015 10:40:26

Diagram 10 b:

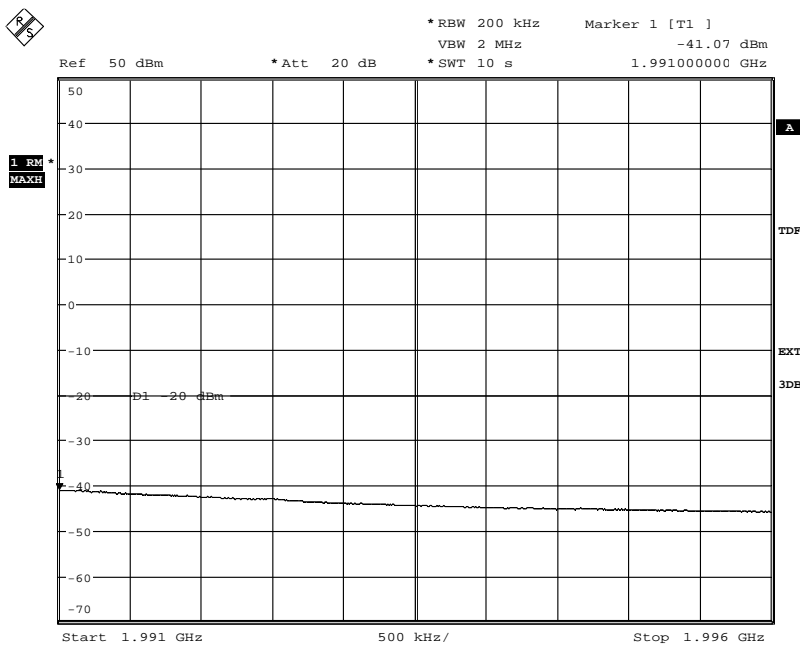

Date: 21.JAN.2015 10:41:35

Appendix 5

Diagram 10 c:

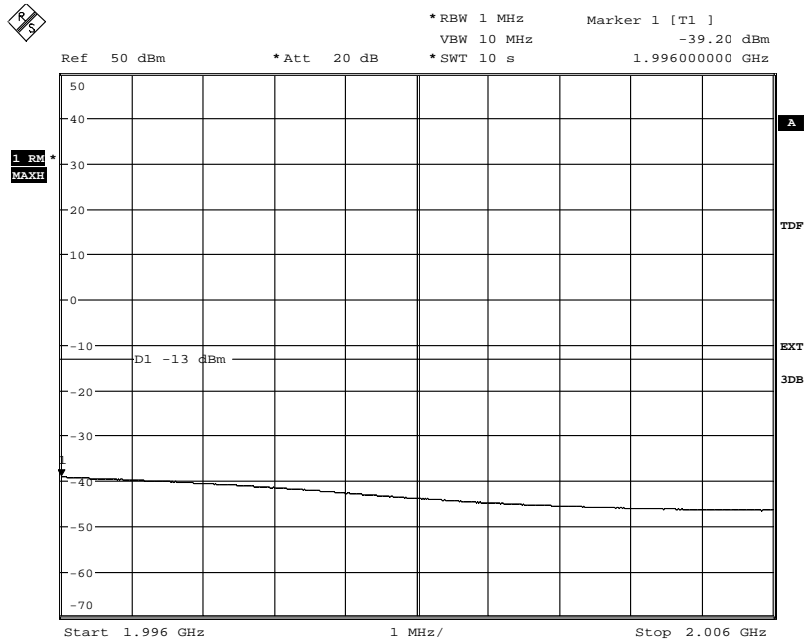

Date: 21.JAN.2015 10:42:35

Appendix 5

Diagram 11 a:

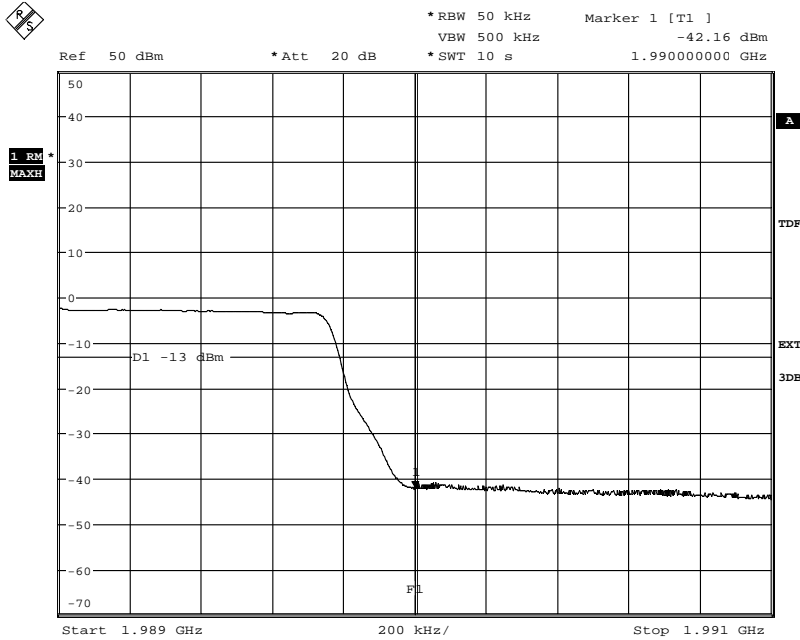

Date: 20.JAN.2015 14:58:18

Diagram 11 b:

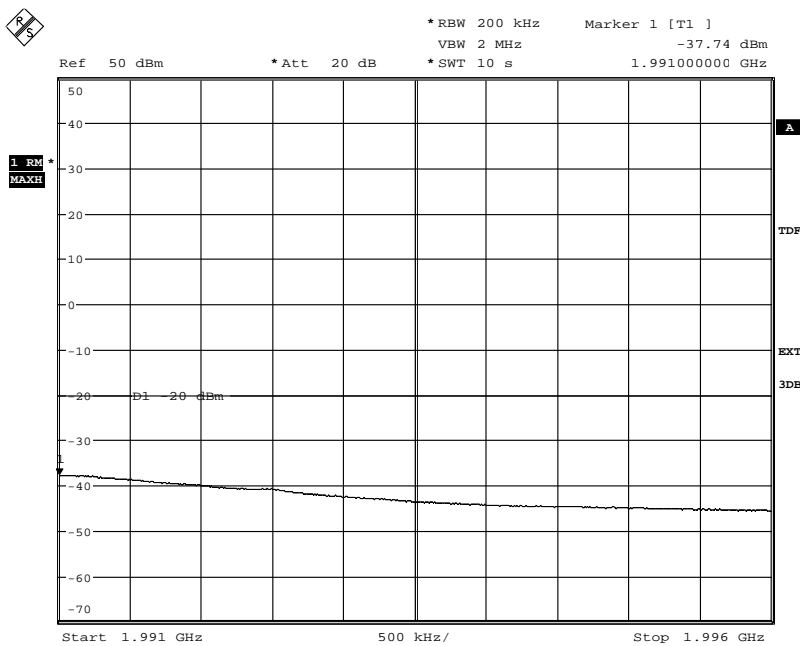

Date: 20.JAN.2015 14:59:32

Appendix 5

Diagram 11 c:

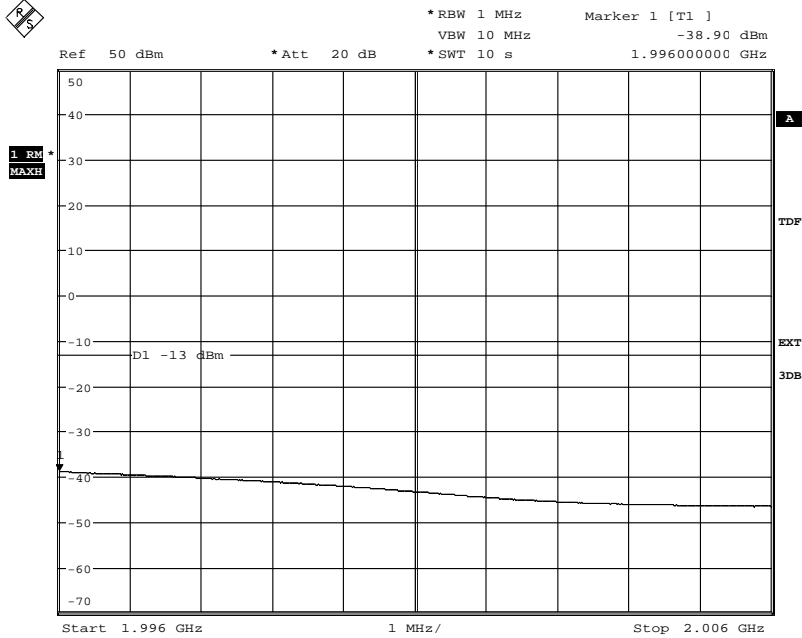

Date: 20.JAN.2015 15:00:57

Appendix 5

Diagram 12 a:

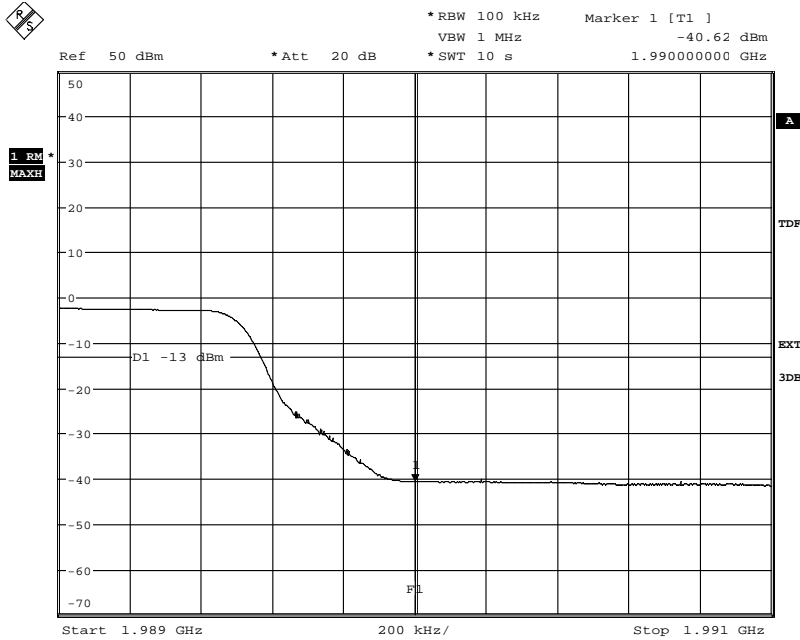

Date: 20.JAN.2015 08:45:10

Diagram 12 b:

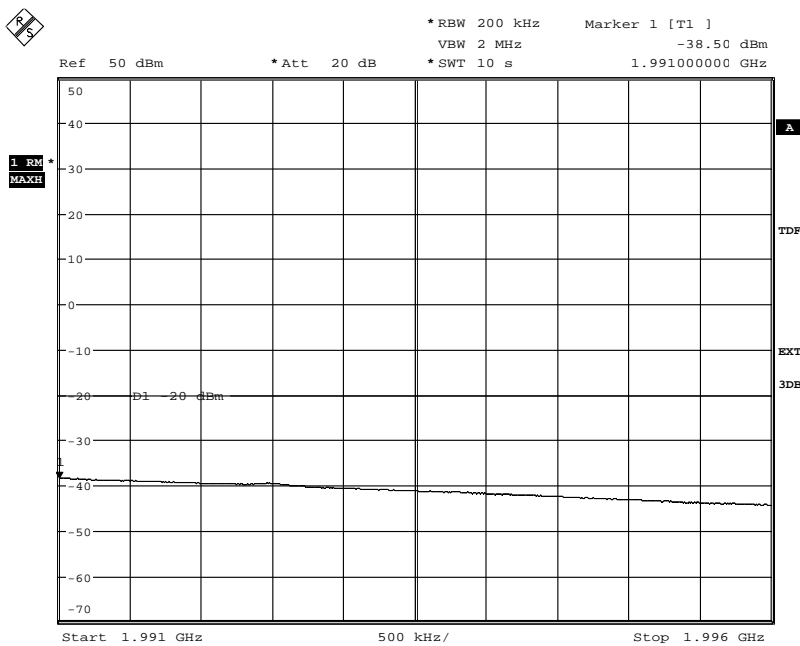

Date: 20.JAN.2015 08:46:48

Appendix 5

Diagram 12 c:

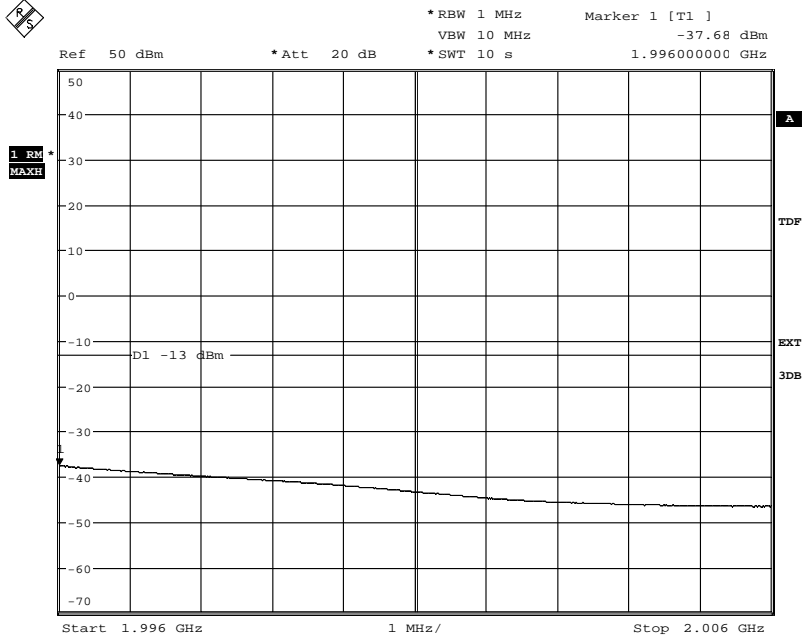

Date: 20.JAN.2015 08:47:43

Appendix 5

Diagram 13 a:

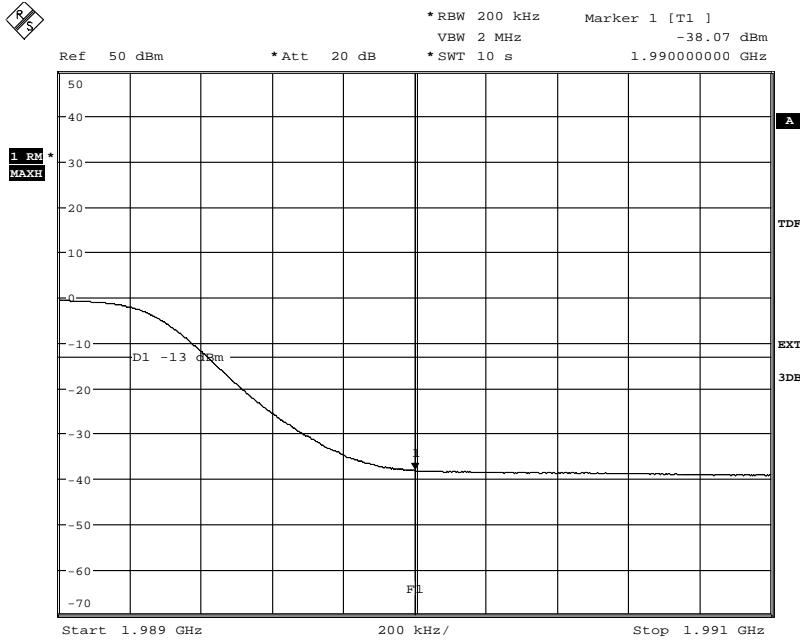

Date: 20.JAN.2015 12:01:25

Diagram 13 b:

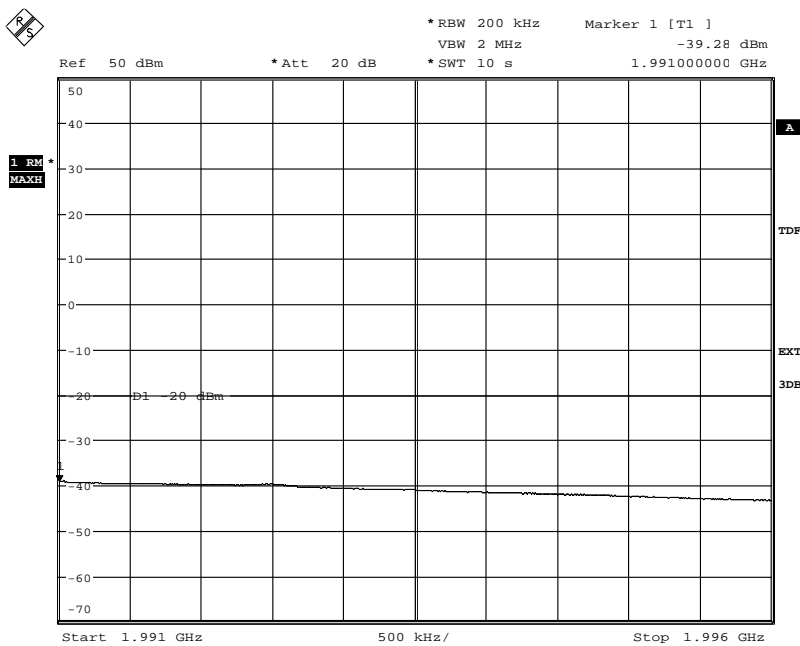

Date: 20.JAN.2015 12:02:47

Appendix 5

Diagram 13 c:

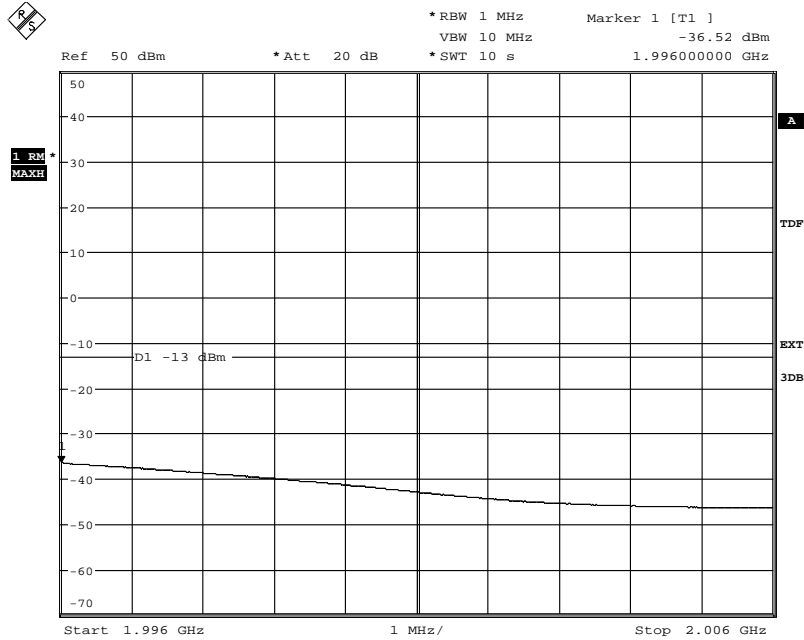

Date: 20.JAN.2015 12:03:59

Appendix 5

Diagram 14 a:

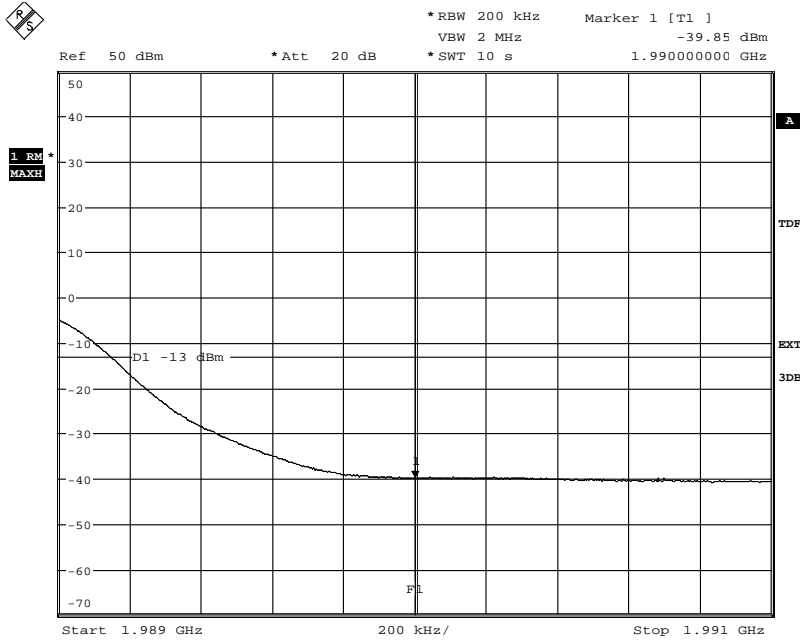

Date: 20.JAN.2015 11:28:13

Diagram 14 b:

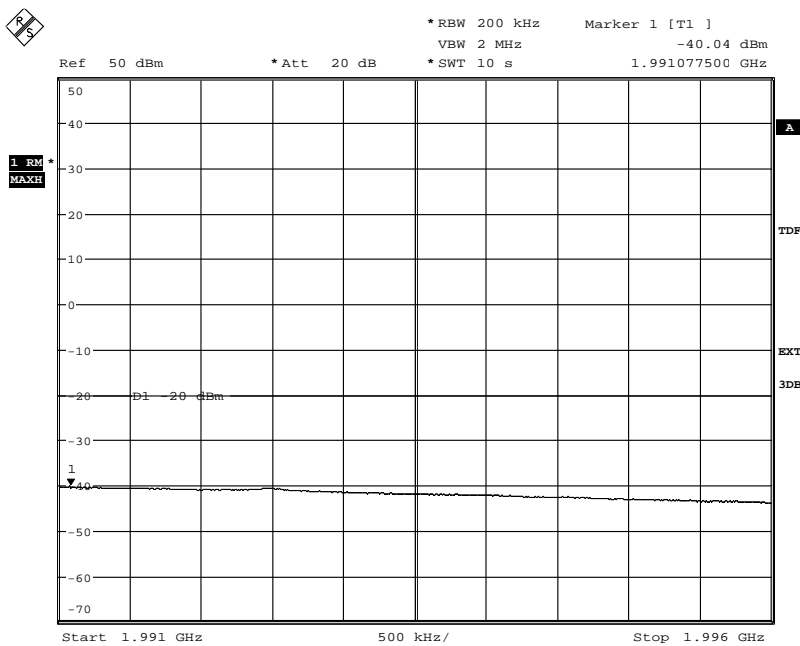

Date: 20.JAN.2015 11:29:22

Appendix 5

Diagram 14 c:

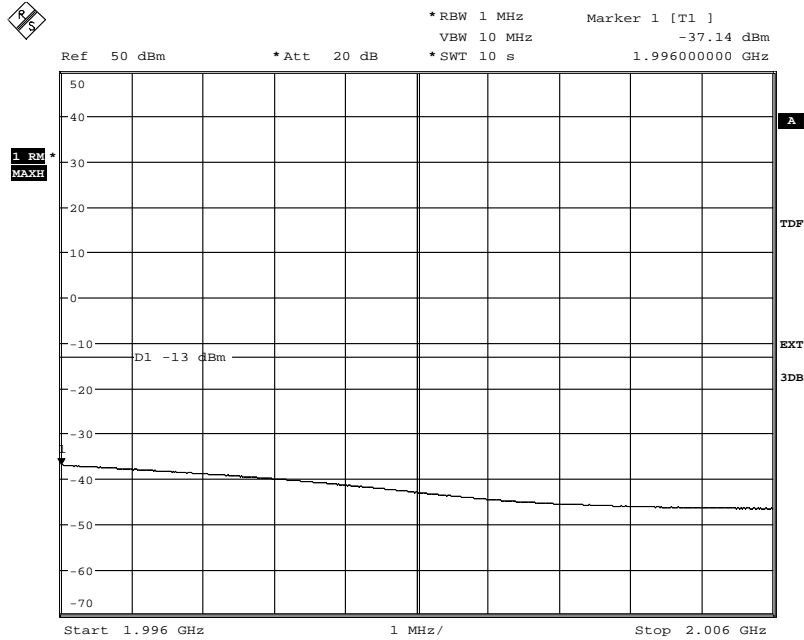

Date: 20.JAN.2015 11:30:14

Appendix 5

Diagram 15 a:

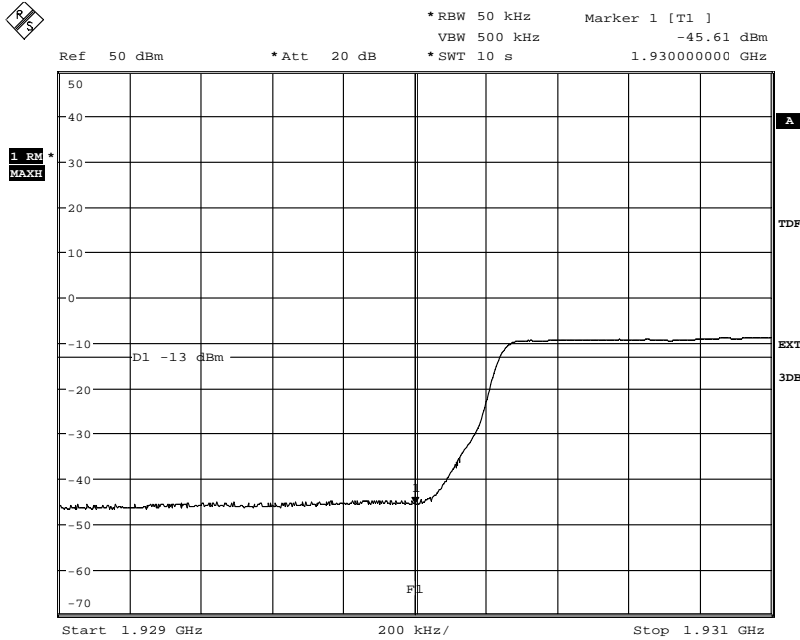

Date: 23.JAN.2015 07:29:04

Diagram 15 b:

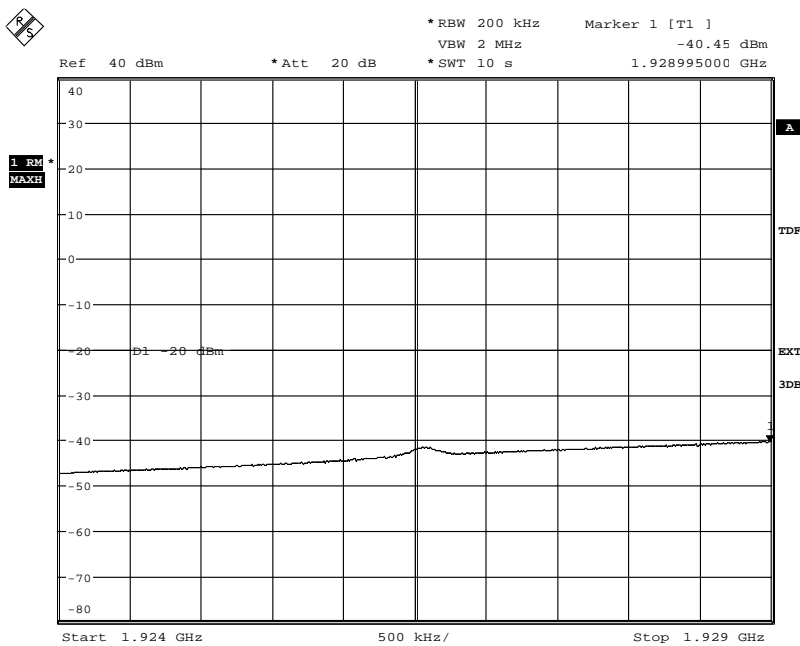

Date: 23.JAN.2015 07:30:27

Appendix 5

Diagram 15 c:

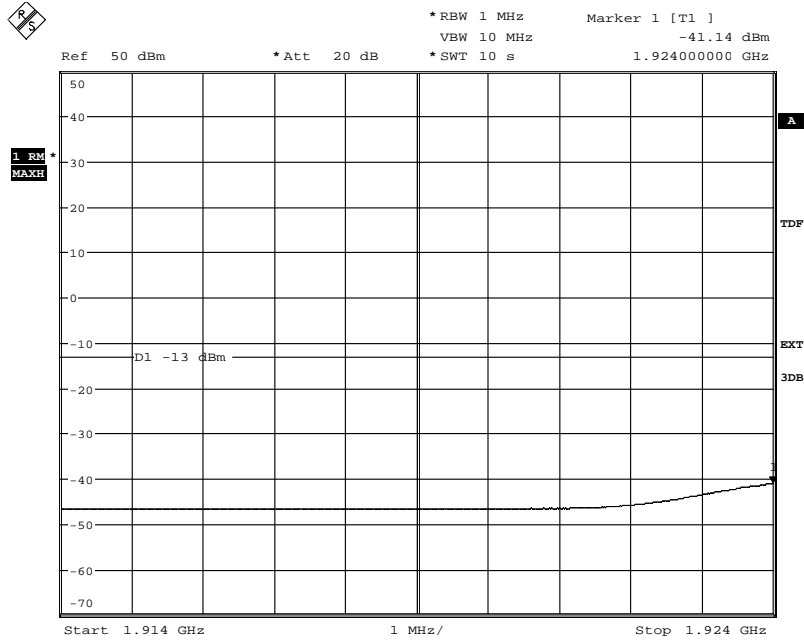

Date: 23.JAN.2015 07:31:20

Appendix 5

Diagram 16 a:

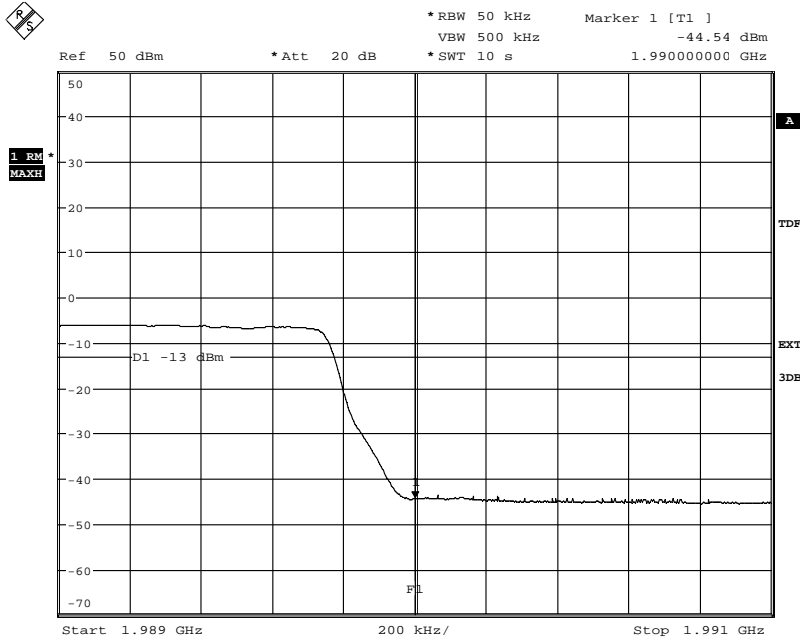

Date: 23.JAN.2015 07:25:20

Diagram 16 b:

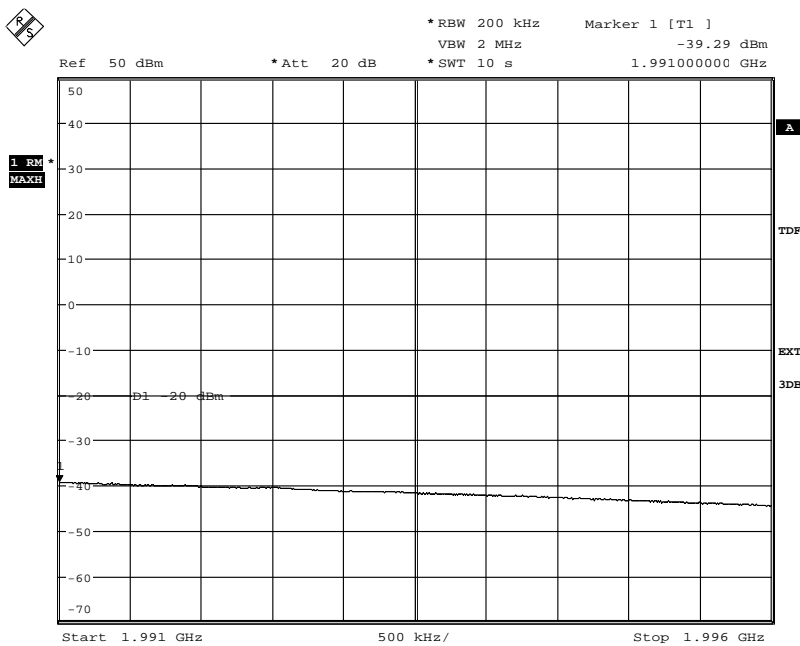

Date: 23.JAN.2015 07:26:30

Appendix 5

Diagram 16 c:

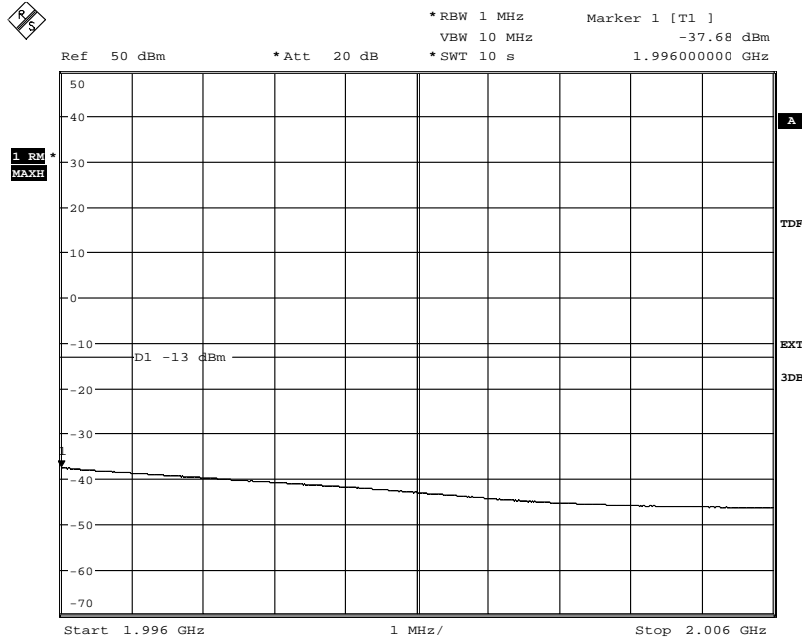

Date: 23.JAN.2015 07:27:21

Appendix 5

Diagram 17 a:

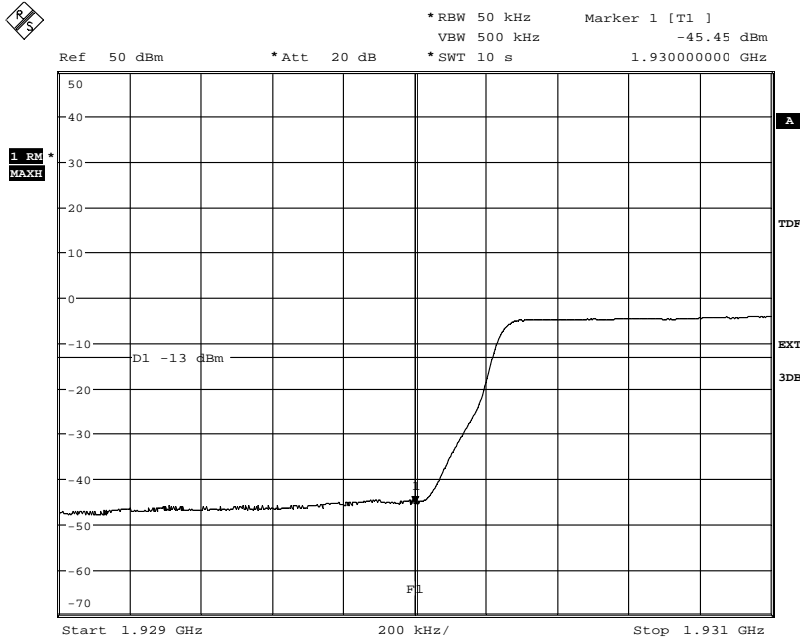

Date: 22.JAN.2015 14:50:30

Diagram 17 b:

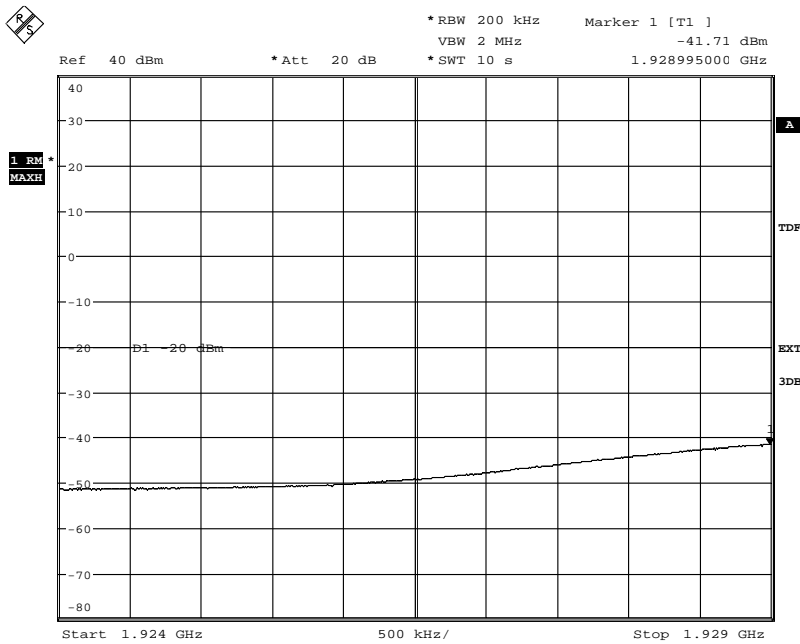

Date: 22.JAN.2015 14:52:43

Appendix 5

Diagram 17 c:

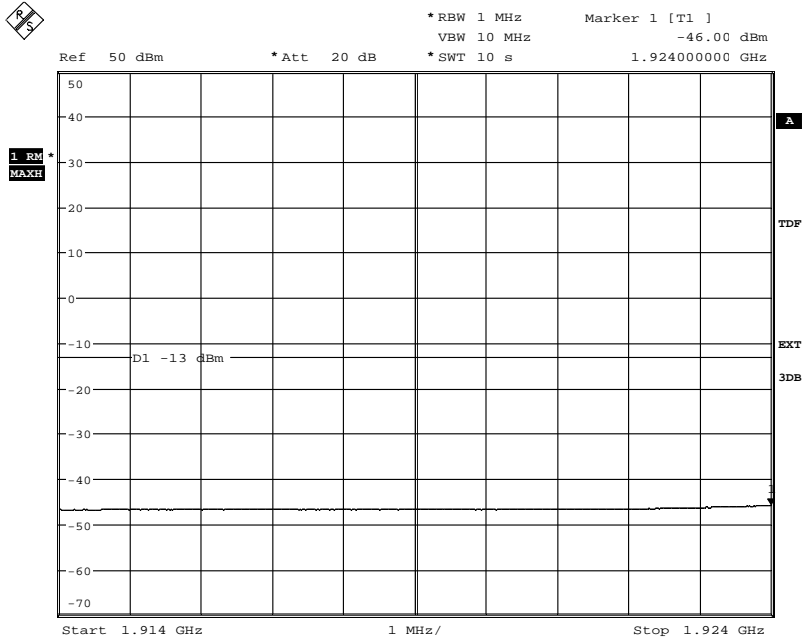

Date: 22.JAN.2015 14:53:42

Appendix 5

Diagram 18 a:

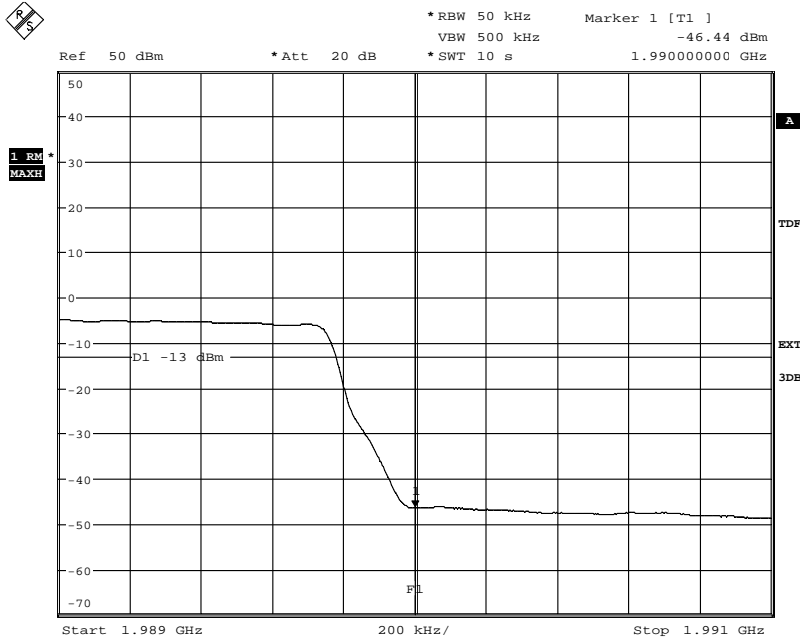

Date: 22.JAN.2015 15:02:30

Diagram 18 b:

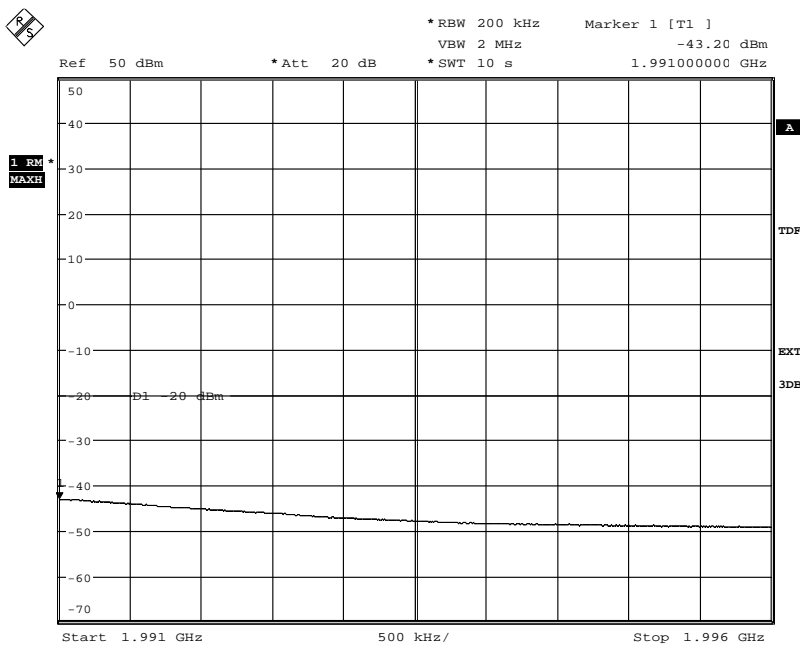

Date: 22.JAN.2015 15:03:47

Appendix 5

Diagram 18 c:

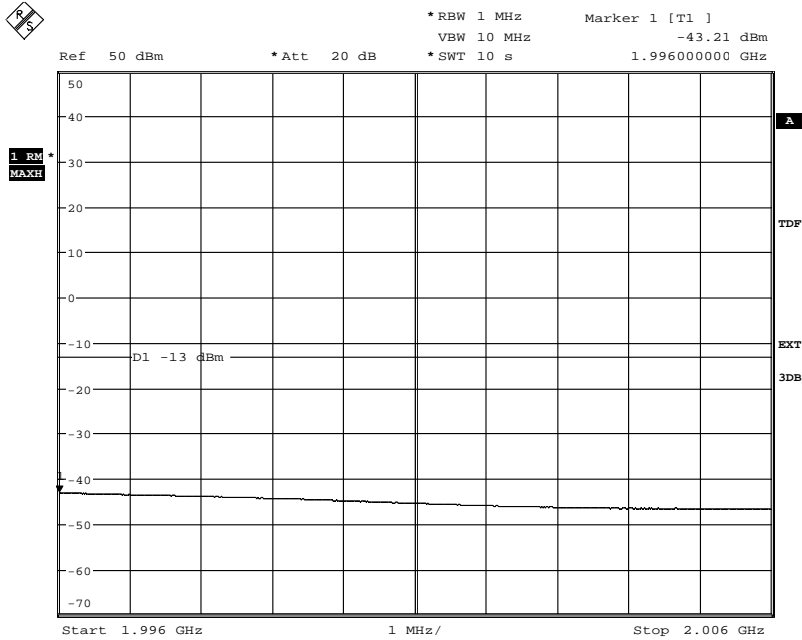

Date: 22.JAN.2015 15:04:38

Appendix 6

Conducted spurious emission measurements according to CFR 47 §24.238 / IC RSS-133 6.5

Date	Temperature	Humidity
2015-01-20	22 °C ± 3 °C	20 % ± 5 %
2015-01-21	22 °C ± 3 °C	20 % ± 5 %
2015-01-22	21 °C ± 3 °C	20 % ± 5 %
2015-01-23	22 °C ± 3 °C	18 % ± 5 %
2015-01-26	22 °C ± 3 °C	18 % ± 5 %

Test set-up and procedure

The measurements were made per definition in §24.238. The output was connected to a spectrum analyser with a RBW setting of 1 MHz and RMS detector activated. The spectrum analyser was connected to an external 10 MHz reference standard during the measurements.

Before comparing the results to the limit, 3 dB [10 log (2)] should be added according to method E), 3), (iii) “measure and add 10 log(N_{ANT})” of FCC KDB662911 D01 Multiple Transmitter Output v02r01.

Measurement equipment	SP number
R&S FSQ 40	504 143
RF attenuator	900 691
HP filter	BX40074
Testo 635, temperature and humidity meter	504 203

Measurement uncertainty: 3.7 dB

Appendix 6

Results

Configuration: RDI Cable 92 m

MIMO mode, single carrier

Diagram	BW configuration / [MHz]	Symbolic name	Tested Port
1 a+b+c+d	5 MHz	B	RF B
2 a+b+c+d	5 MHz	M	RF B
3 a+b+c+d	5 MHz	T	RF B

MIMO mode, multi carrier

Diagram	BW configuration	Symbolic name	Tested Port
4 a+b+c+d+e	5 MHz	B2/T2im2	RF B

Appendix 6

Configuration: RDI Cable 200 m

MIMO mode, single carrier

Diagram	BW configuration / [MHz]	Symbolic name	Tested Port
5 a+b+c+d+e	5 MHz	B	RF B
6 a+b+c+d+e	5 MHz	M	RF B
7 a+b+c+d+e	5 MHz	T	RF A
8 a+b+c+d+e	5 MHz	T	RF B
9 a+b+c+d+e	10 MHz	T	RF B
10 a+b+c+d+e	15 MHz	T	RF B
11 a+b+c+d+e	20 MHz	T	RF B

MIMO mode, multi carrier

Diagram	BW configuration	Symbolic name	Tested Port
12 a+b+c+d+e	5 MHz	B2im1	RF B
13 a+b+c+d+e	5 MHz	T2im1	RF B
14 a+b+c+d+e	5 MHz	B2/T2im2	RF B
15 a+b+c+d+e	20 MHz	T2-20	RF B
16 a	15 MHz	T2-15	RF B
17 a	10 MHz	T2-10	RF B

Configuration: RDI Cable 20 m

MIMO mode, single carrier

Diagram	BW configuration / [MHz]	Symbolic name	Tested Port
18 a+b+c+d	5 MHz	M	RF B

MIMO mode, multi carrier

Diagram	BW configuration	Symbolic name	Tested Port
19 a+b+c+d+e	5 MHz	B2/T2im2	RF B

Appendix 6

Remark

The emission at 9 kHz on the plots was not generated by the test object. A complementary measurement with a smaller RBW showed that it was related to the LO feed-through.

The highest fundamental frequency is 1.99 GHz. The measurements were made up to 20 GHz (10x1.99 GHz = 19.90 GHz).

Limits

§24.238 and RSS-133 6.5

Outside a licensee's frequency band(s) of operation the power of any emission shall be attenuated below the transmitter power (P) by at least $43 + 10 \log (P)$ dB, resulting in a limit of -13 dBm per 1 MHz RBW.

Complies?	Yes
-----------	-----

Appendix 6

Diagram 1 a:

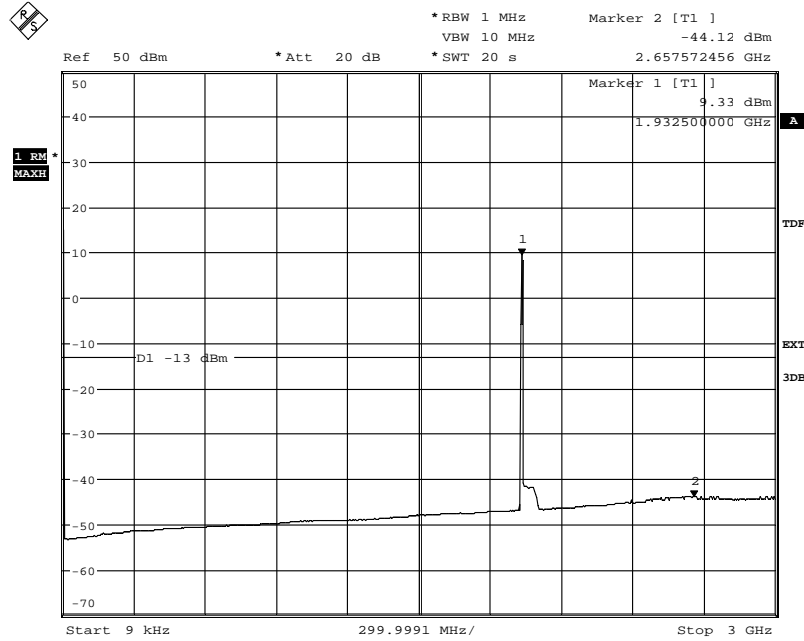

Date: 22.JAN.2015 10:43:26

Diagram1 b:

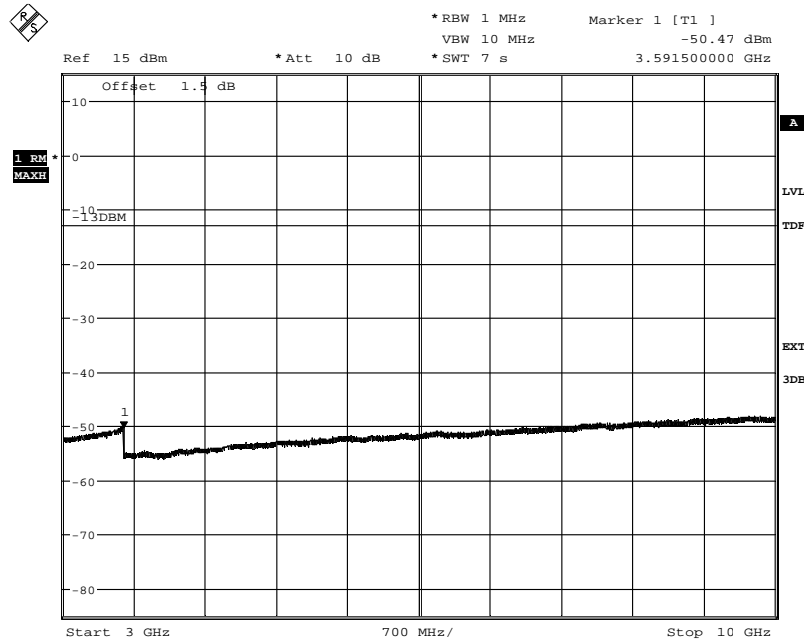

Date: 22.JAN.2015 08:43:25

Appendix 6

Diagram 1 c:

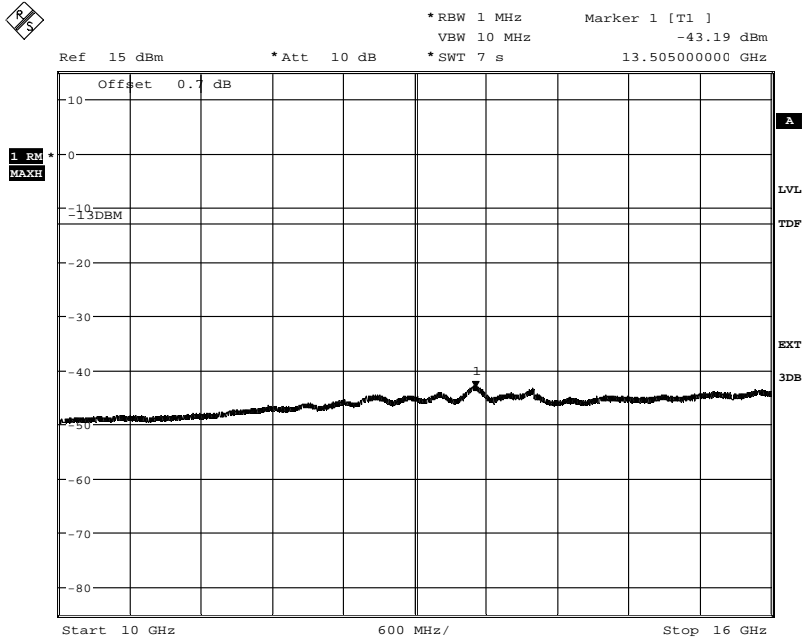

Date: 22.JAN.2015 08:44:24

Diagram 1 d:

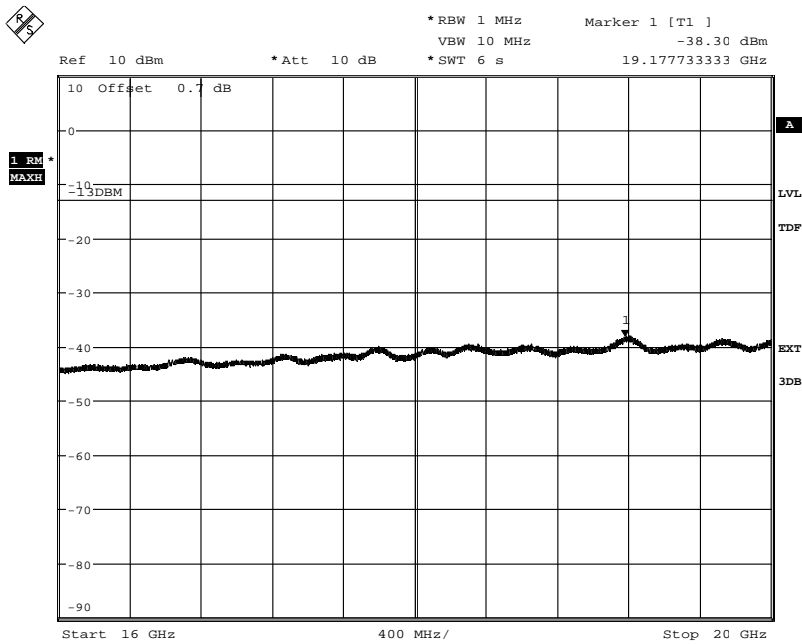

Date: 22.JAN.2015 08:42:12

Appendix 6

Diagram 2 a:

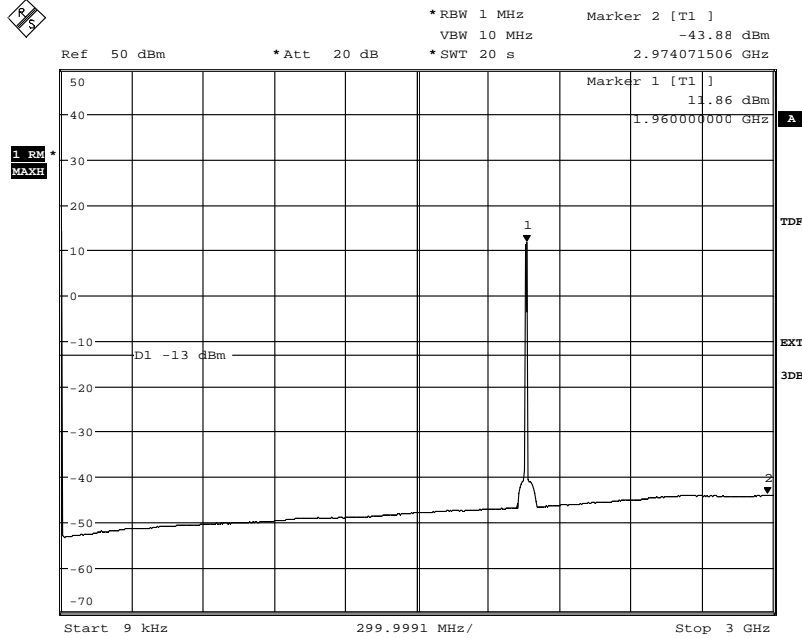

Date: 22.JAN.2015 08:22:56

Diagram 2 b:

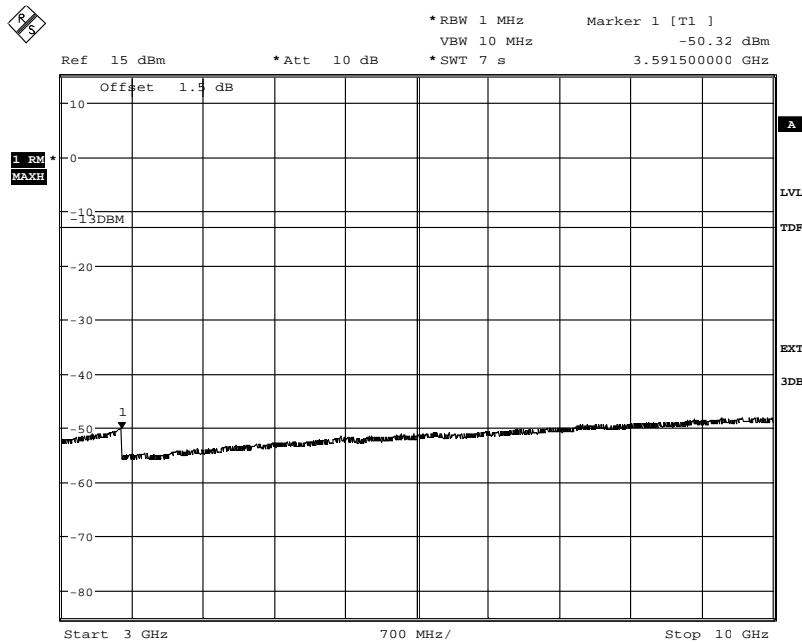

Date: 22.JAN.2015 08:27:02

Appendix 6

Diagram 2 c:

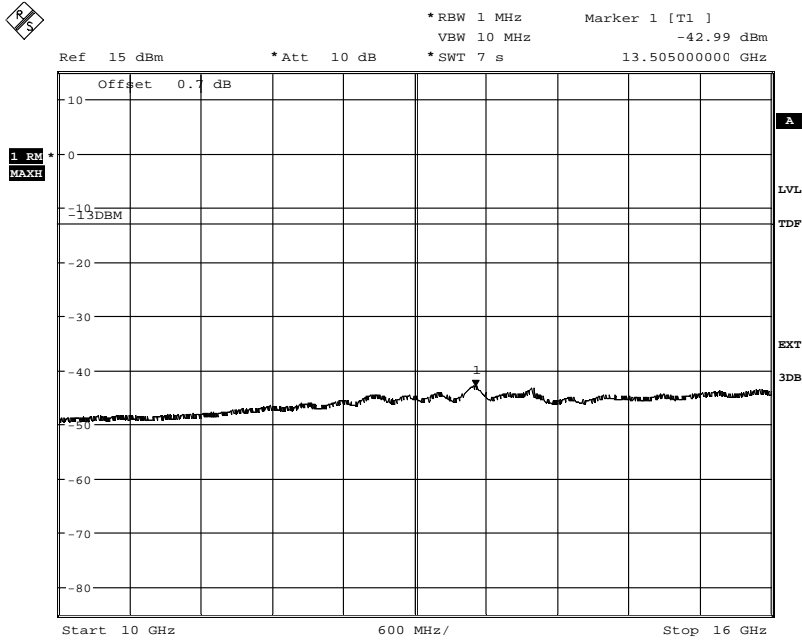

Date: 22.JAN.2015 08:29:08

Diagram 2 d:

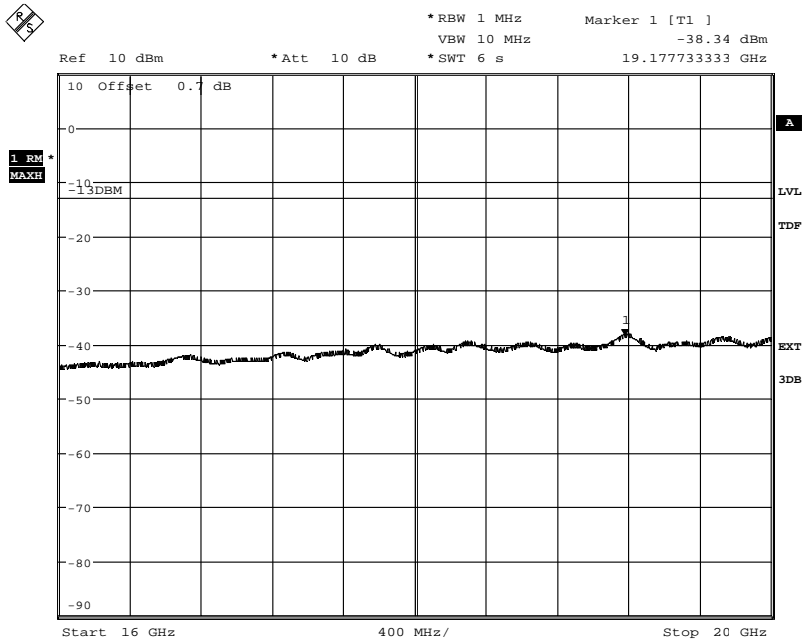

Date: 22.JAN.2015 08:39:05

Appendix 6

Diagram 3 a:

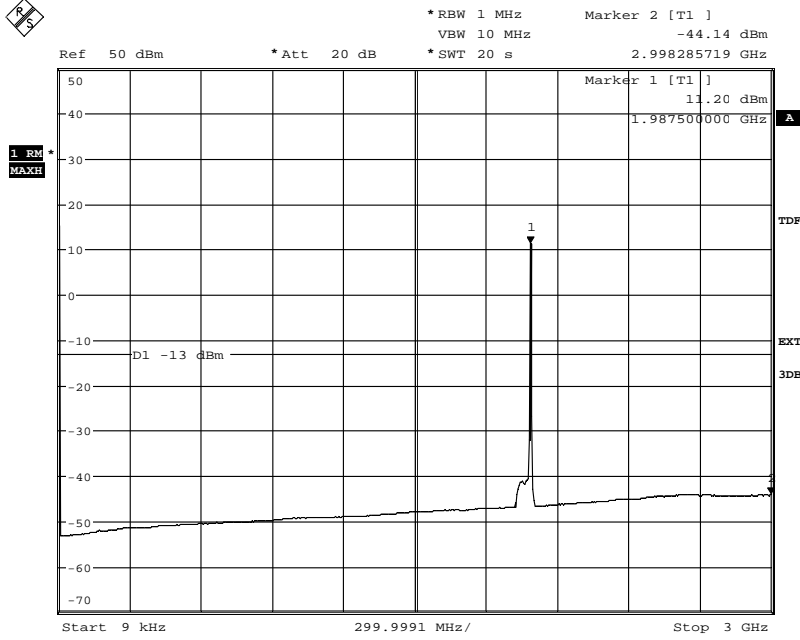

Date: 22.JAN.2015 10:27:12

Diagram 3 b:

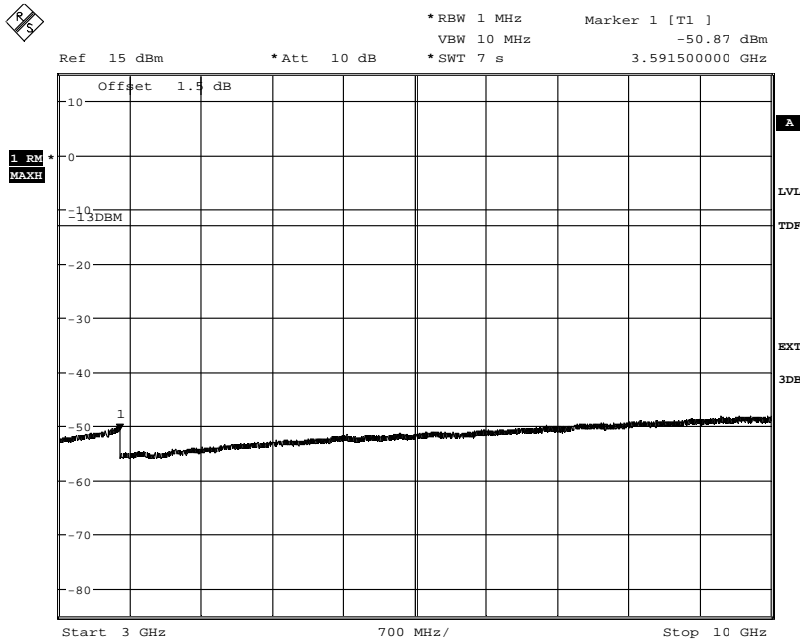

Date: 22.JAN.2015 08:47:35

Appendix 6

Diagram 3 c:

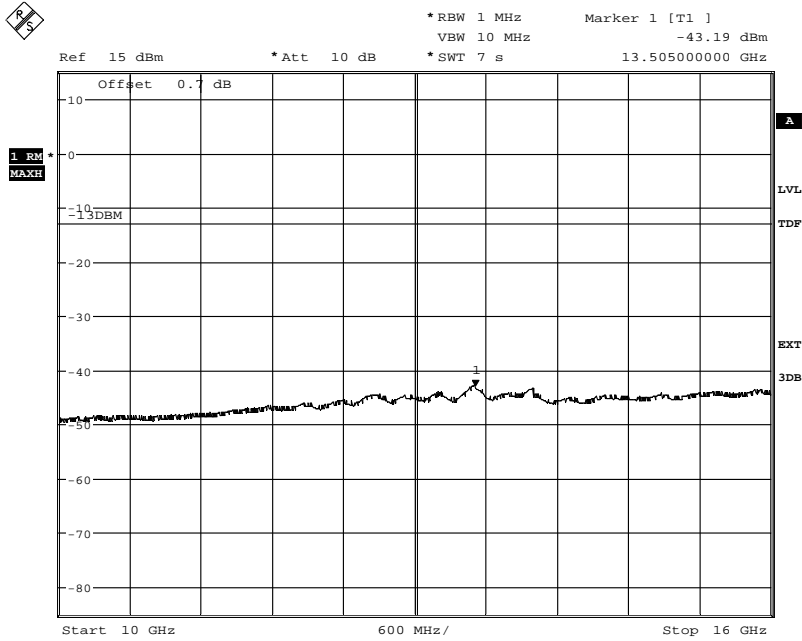

Date: 22.JAN.2015 08:45:24

Diagram 3 d:

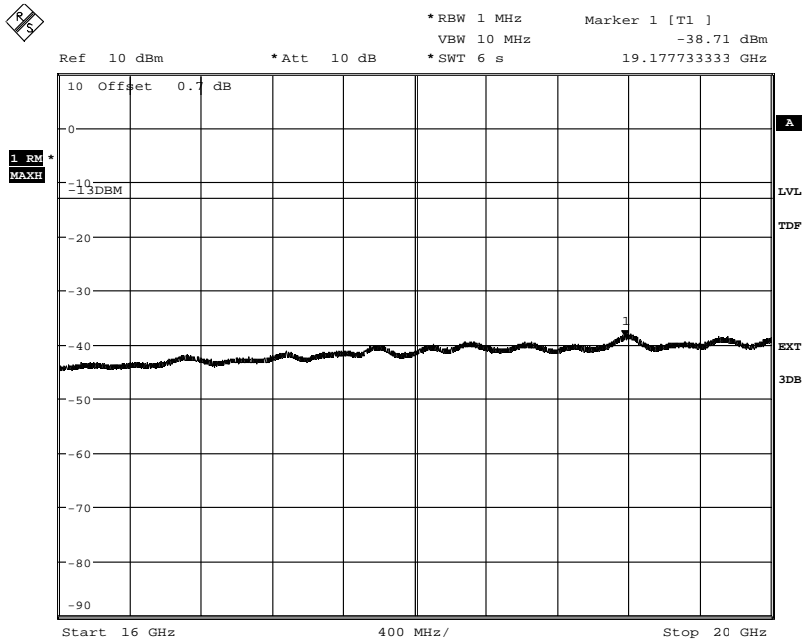

Date: 22.JAN.2015 08:46:31

Appendix 6

Diagram 4 a:

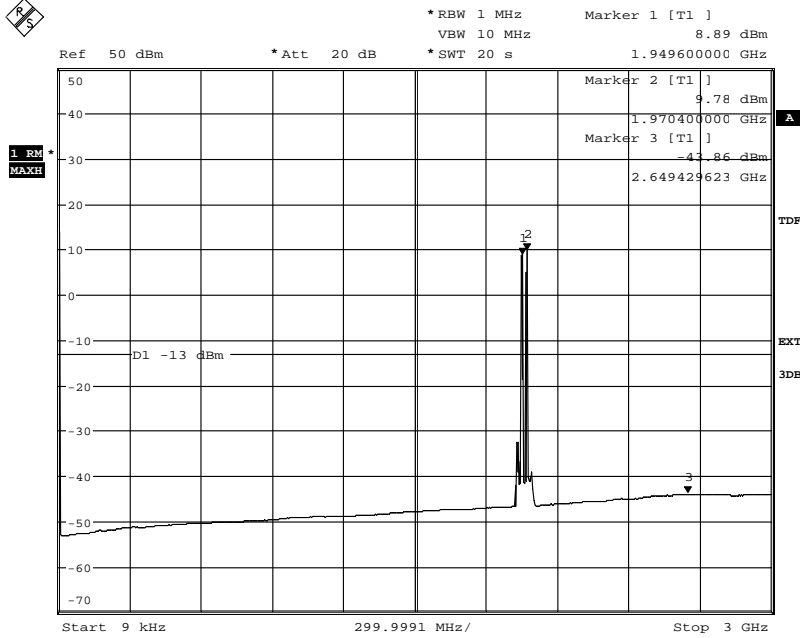

Date: 26.JAN.2015 09:35:17

Diagram 4 b:

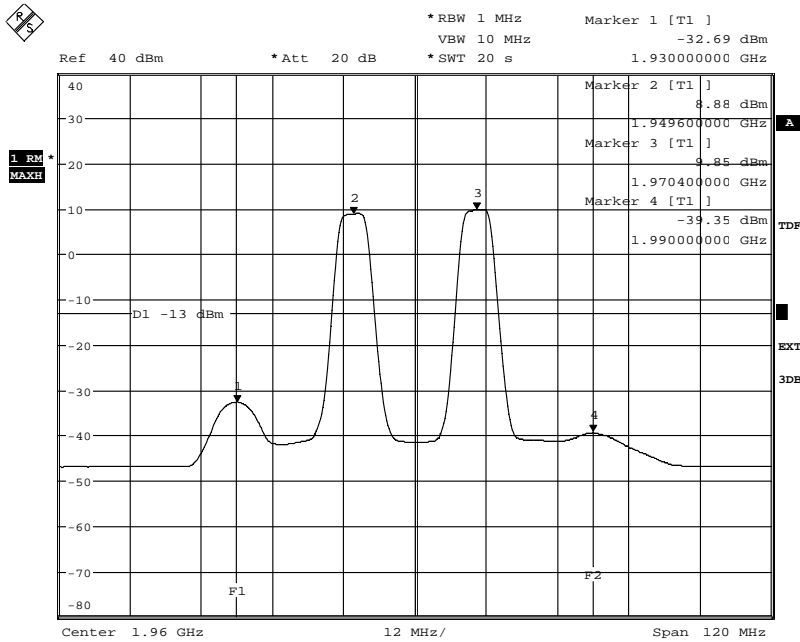

Date: 26.JAN.2015 09:38:19

Appendix 6

Diagram 4 c:

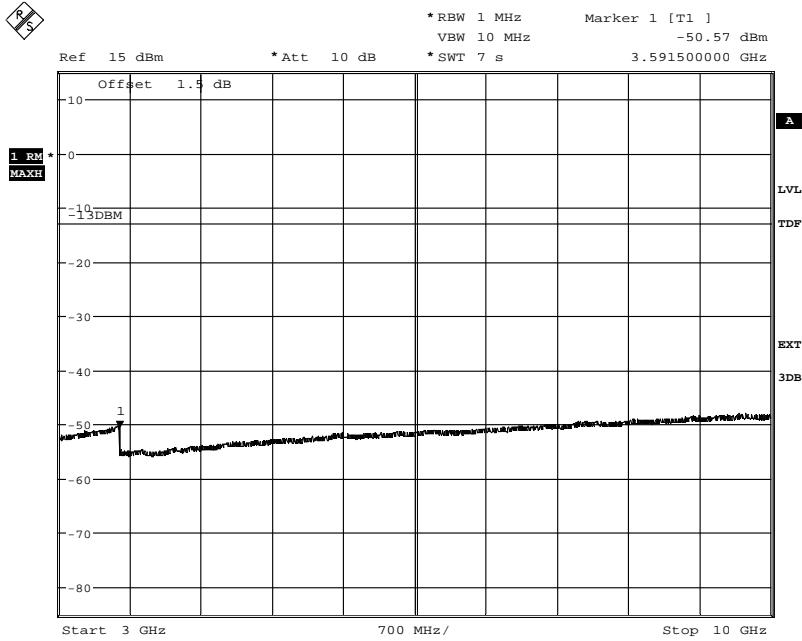

Date: 26.JAN.2015 09:39:50

Diagram 4 d:

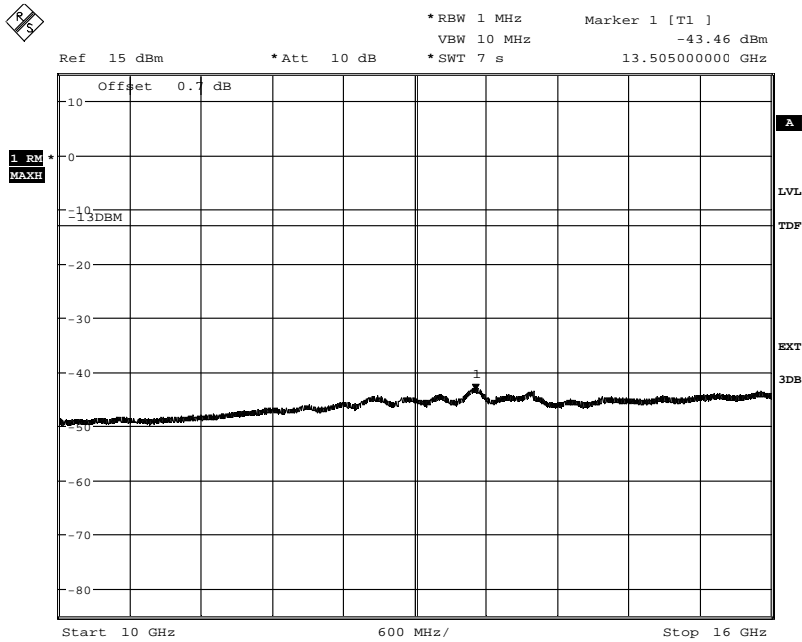

Date: 26.JAN.2015 09:41:07

Appendix 6

Diagram 4 e:

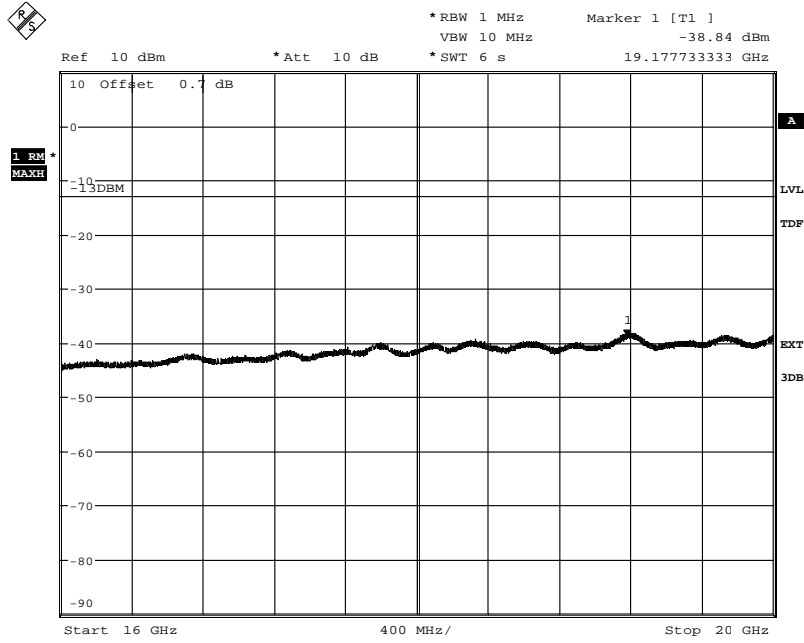

Date: 26.JAN.2015 09:42:06

Appendix 6

Diagram 5 a:

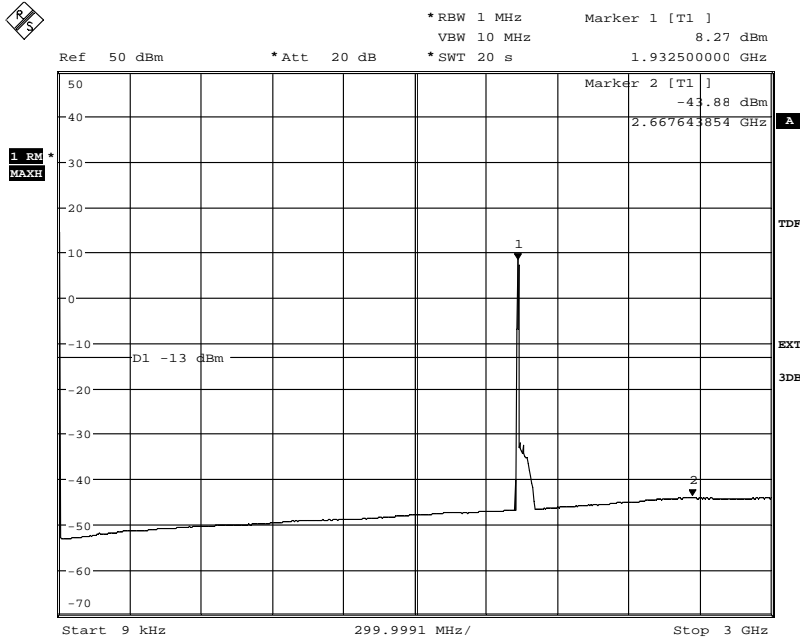

Date: 21.JAN.2015 08:58:27

Diagram 5 b:

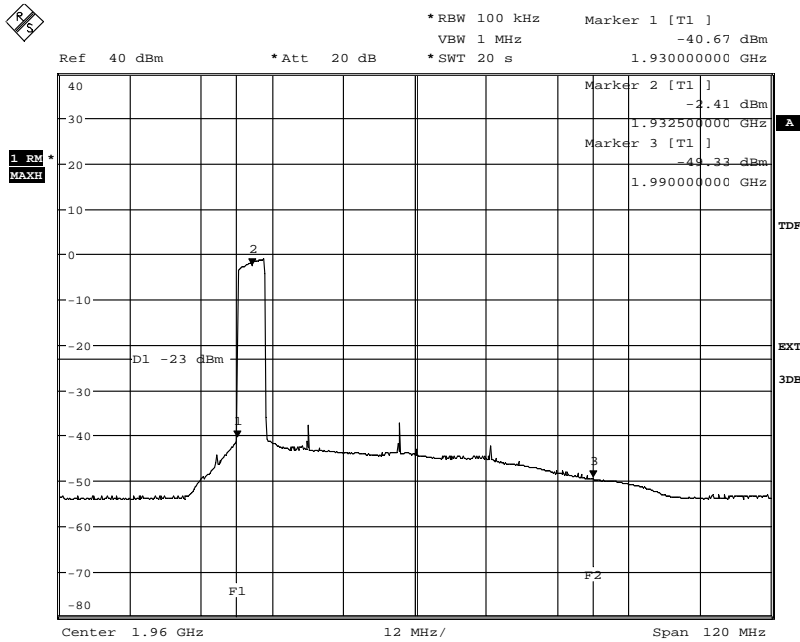

Date: 21.JAN.2015 08:55:47

Appendix 6

Diagram 5 c:

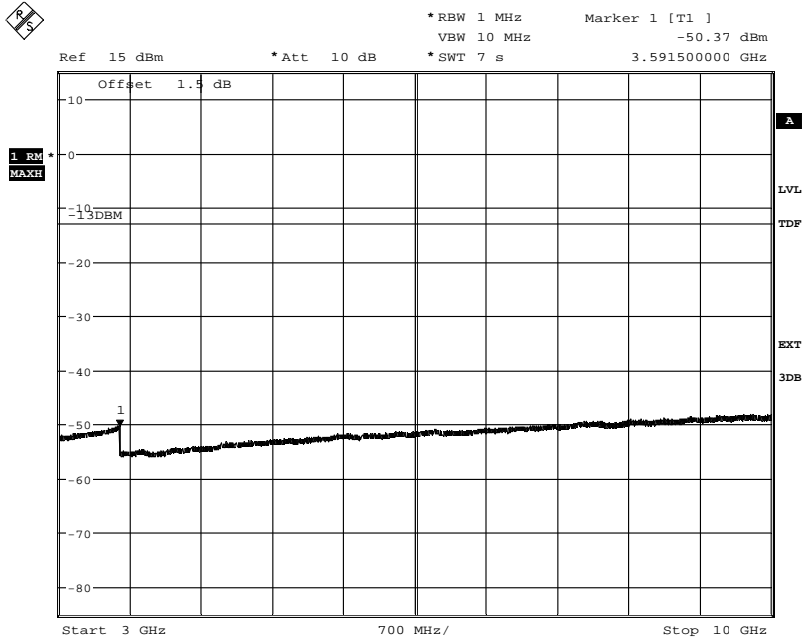

Date: 21.JAN.2015 10:19:26

Diagram 5 d:

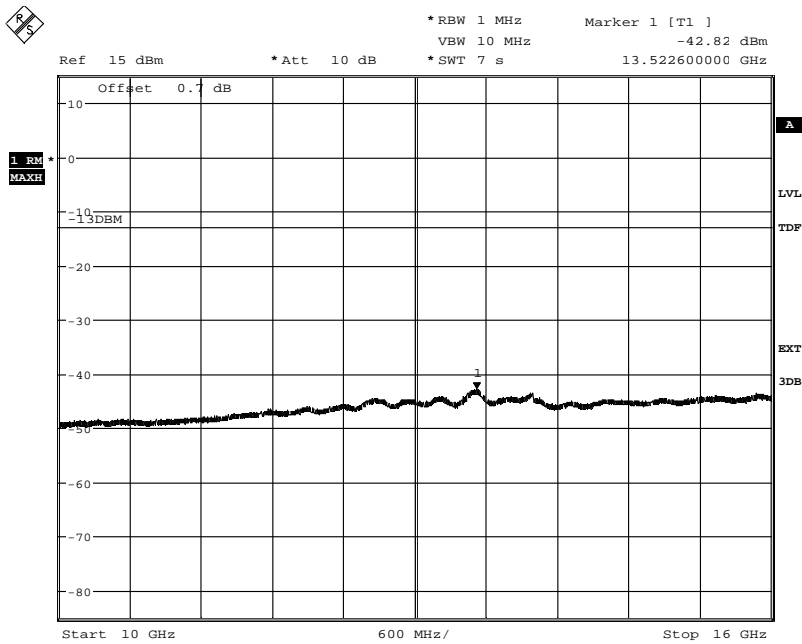

Date: 21.JAN.2015 10:20:43

Appendix 6

Diagram 5 e:

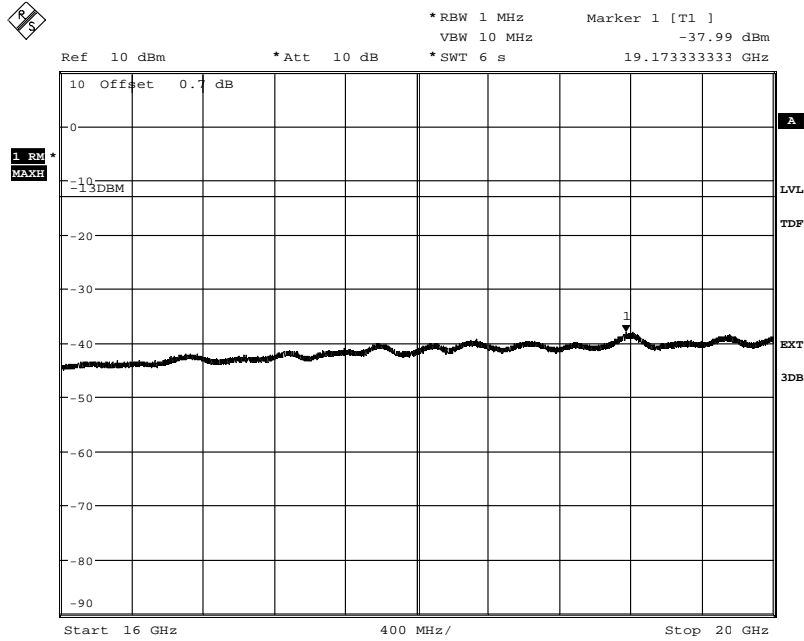

Date: 21.JAN.2015 10:21:53

Appendix 6

Diagram 6 a:

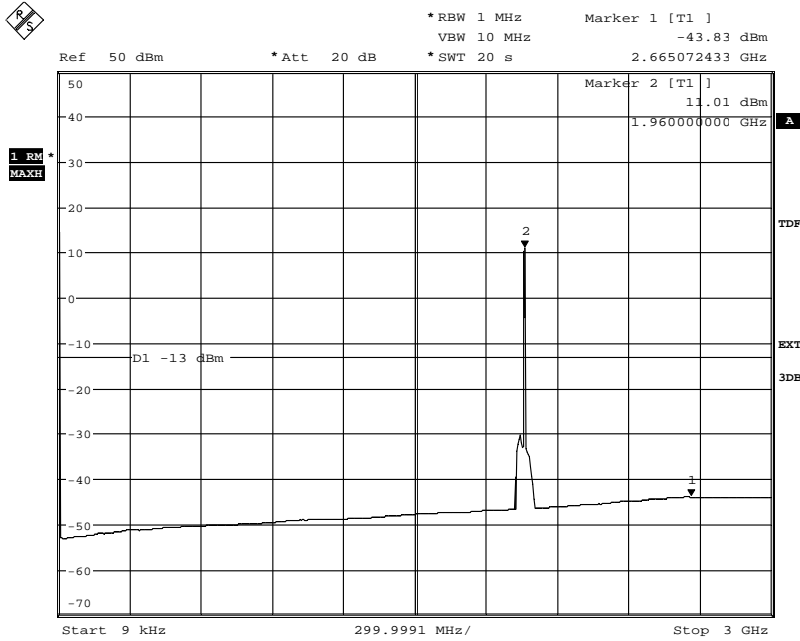

Date: 21.JAN.2015 08:49:36

Diagram 6 b:

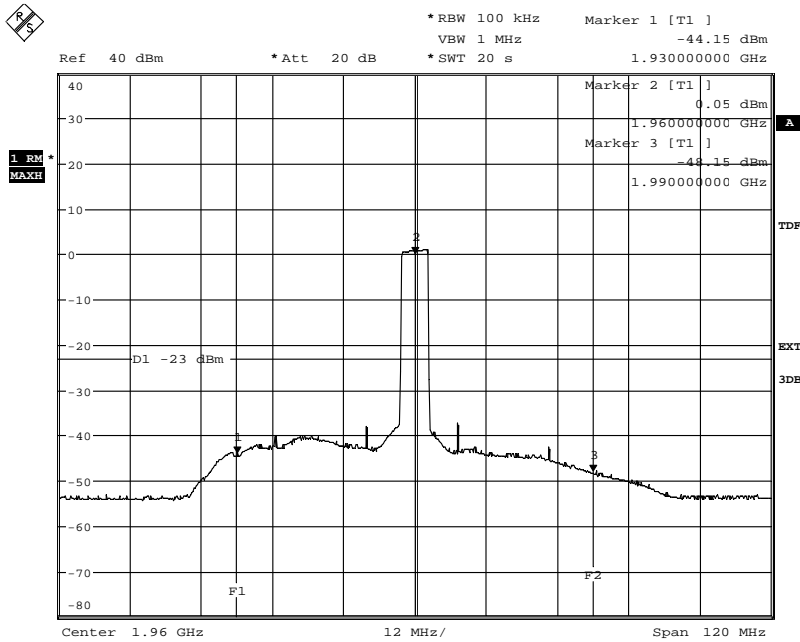

Date: 21.JAN.2015 08:51:34

Appendix 6

Diagram 6 c:

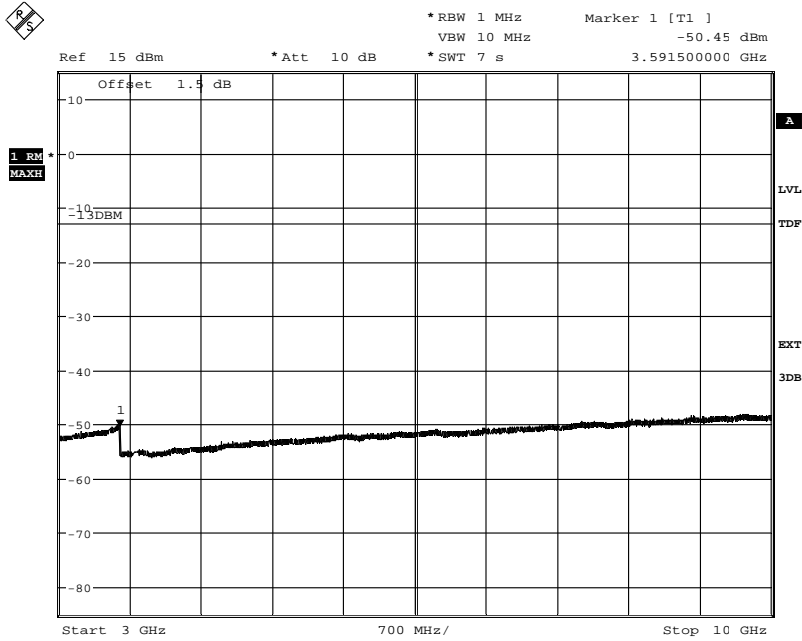

Date: 21.JAN.2015 10:26:26

Diagram 6 d:

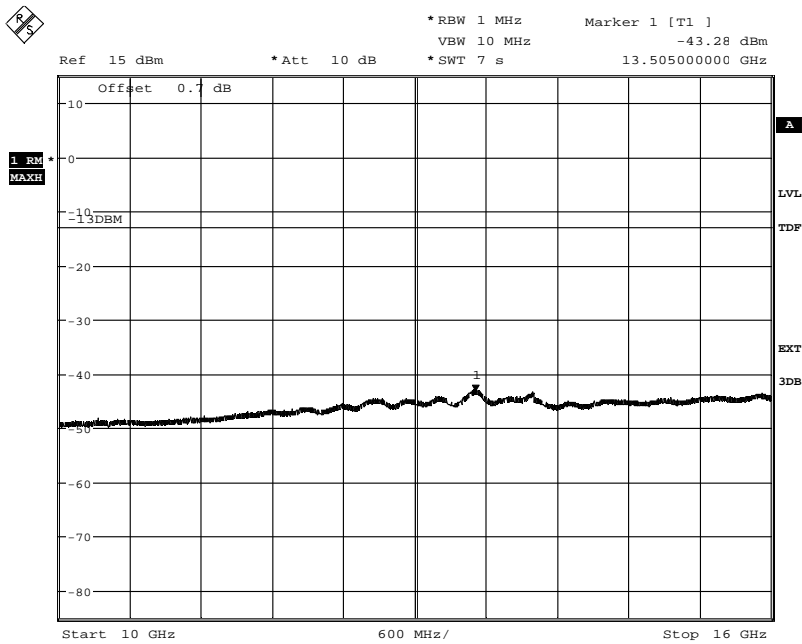

Date: 21.JAN.2015 10:25:09

Appendix 6

Diagram 6 e:

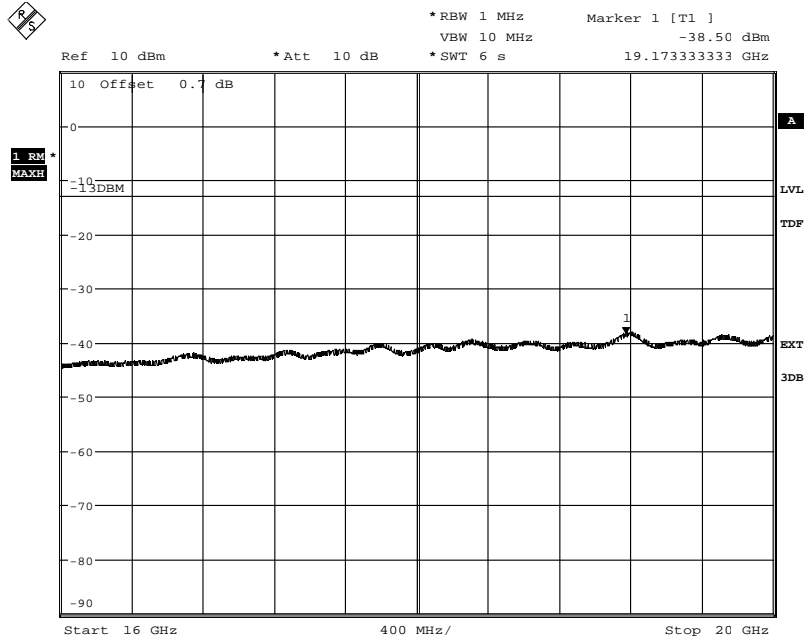

Date: 21.JAN.2015 10:23:43

Appendix 6

Diagram 7 a:

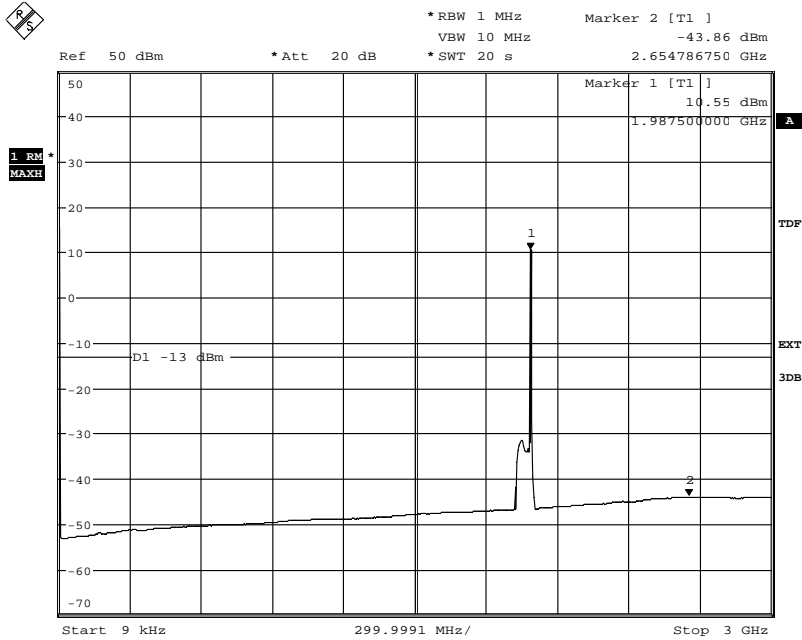

Date: 21.JAN.2015 10:36:11

Diagram 7 b:

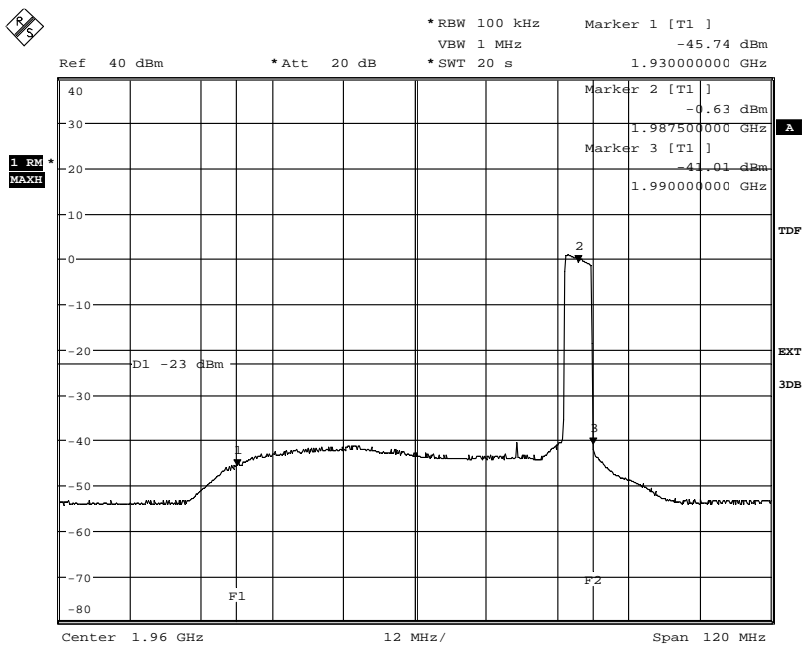

Date: 21.JAN.2015 10:37:45

Appendix 6

Diagram 7 c:

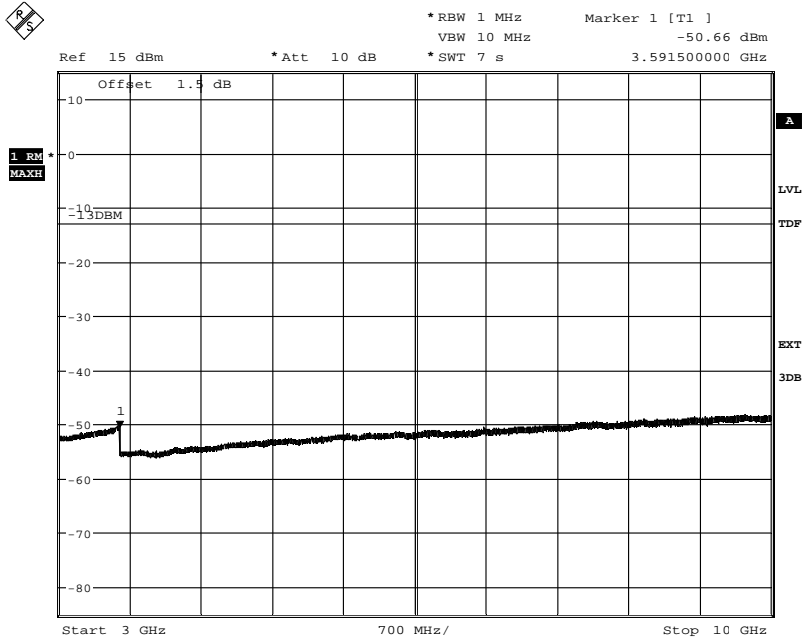

Date: 21.JAN.2015 10:29:23

Diagram 7 d:

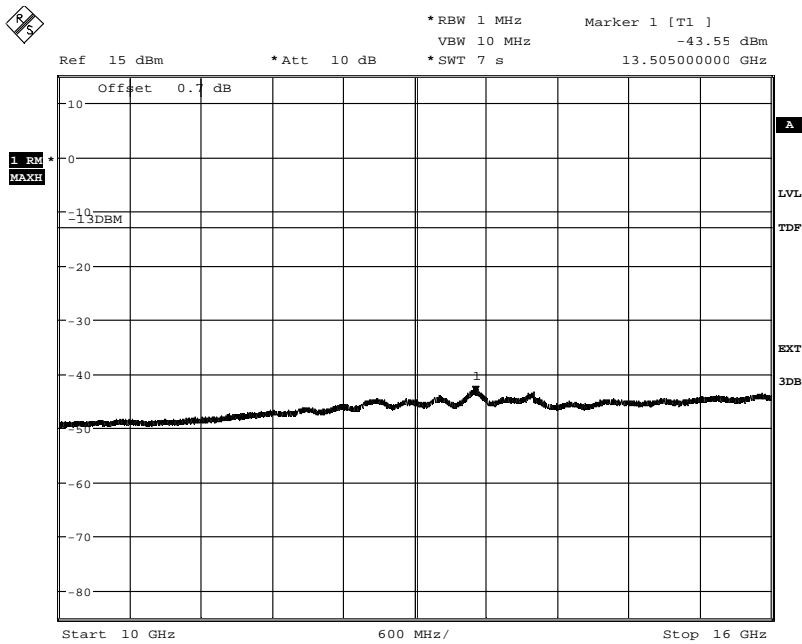

Date: 21.JAN.2015 10:30:33

Appendix 6

Diagram 7 e:

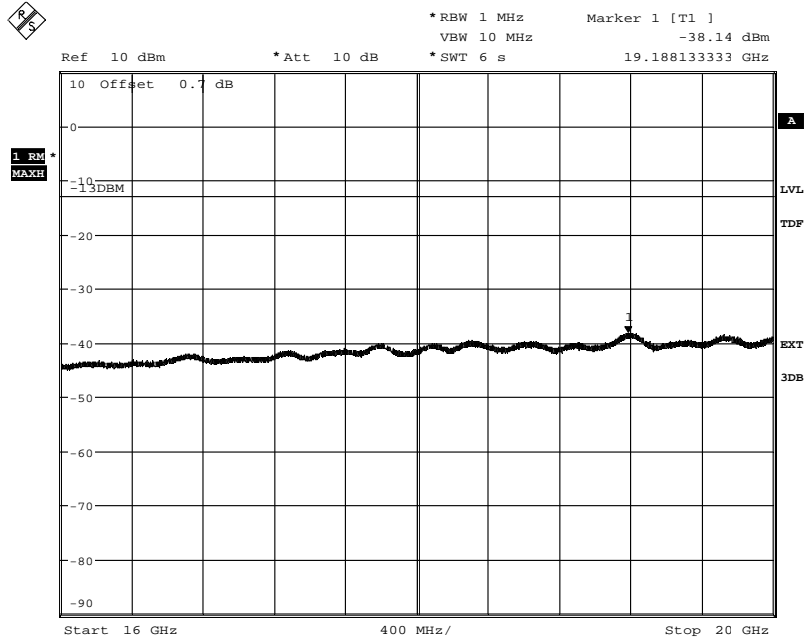

Date: 21.JAN.2015 10:31:59

Appendix 6

Diagram 8 a:

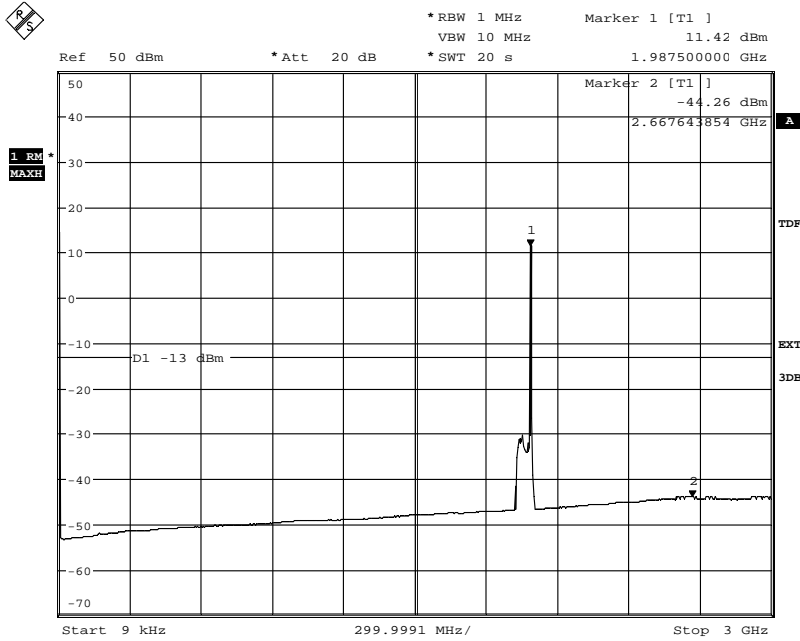

Date: 21.JAN.2015 09:00:38

Diagram 8 b:

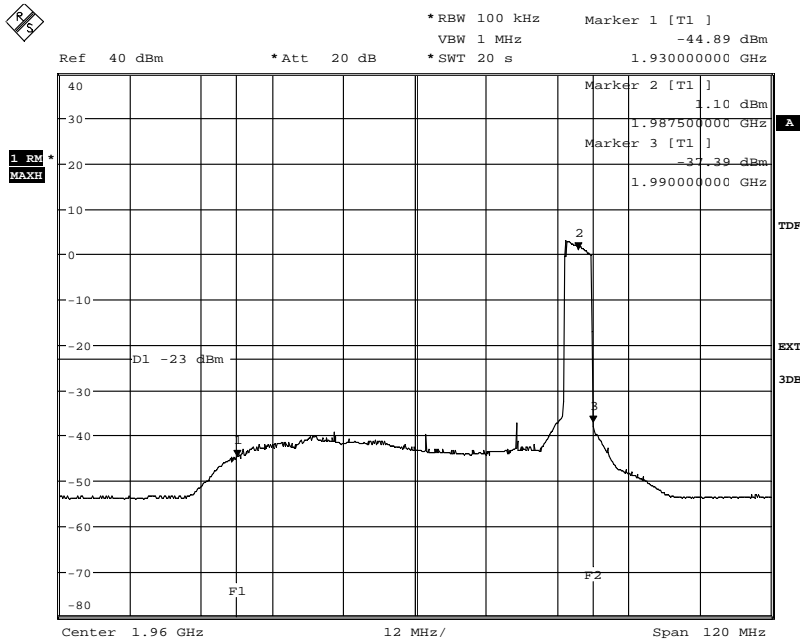

Date: 20.JAN.2015 15:18:20

Appendix 6

Diagram 8 c:

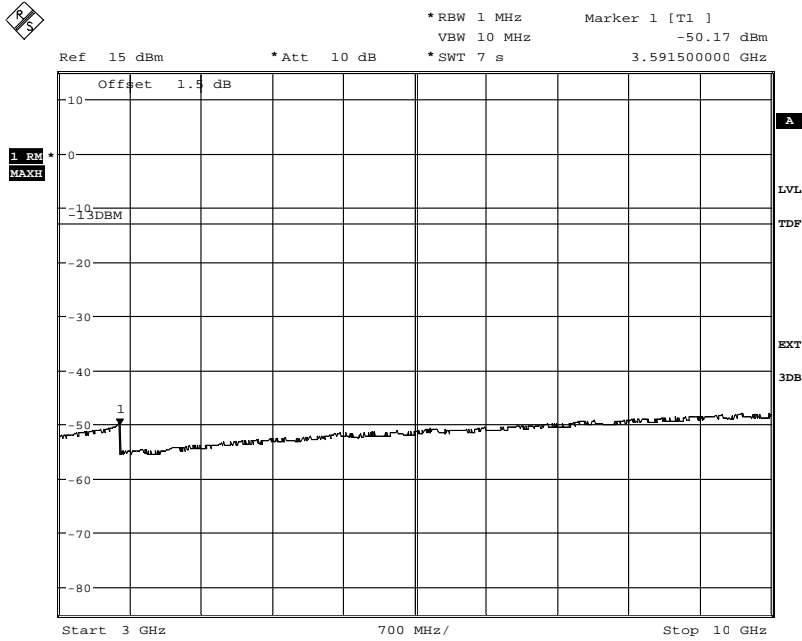

Date: 20.JAN.2015 15:07:49

Diagram 8 d:

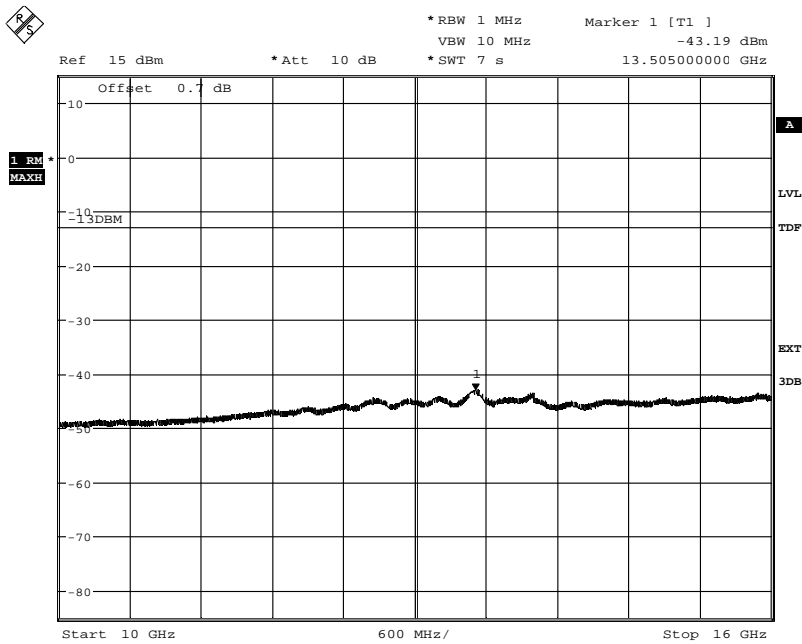

Date: 20.JAN.2015 15:09:01

Appendix 6

Diagram 8 e:

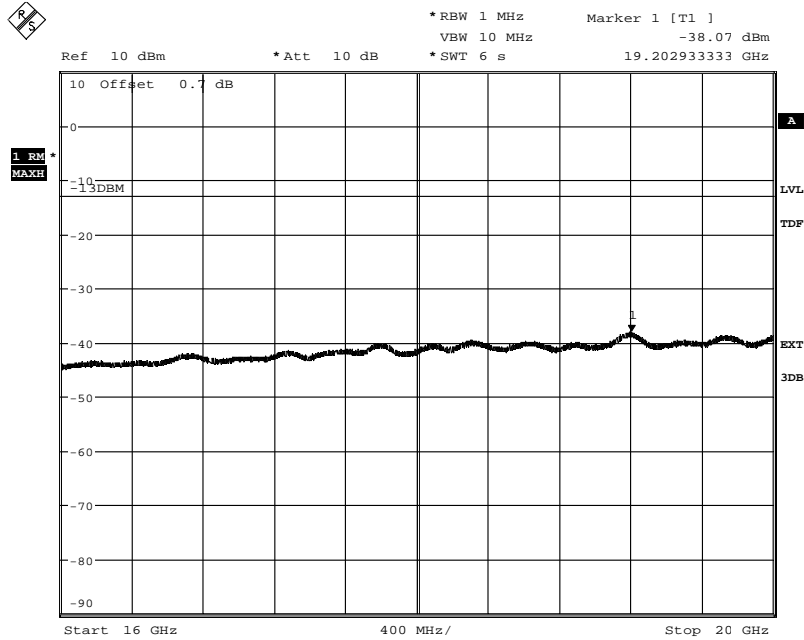

Date: 20.JAN.2015 15:10:21

Appendix 6

Diagram 9 a:

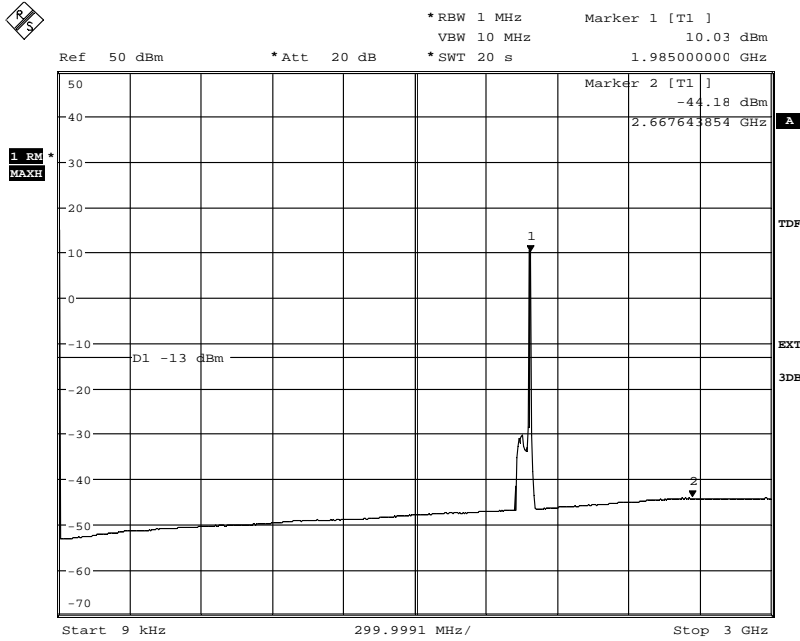

Date: 21.JAN.2015 09:43:15

Diagram 9 b:

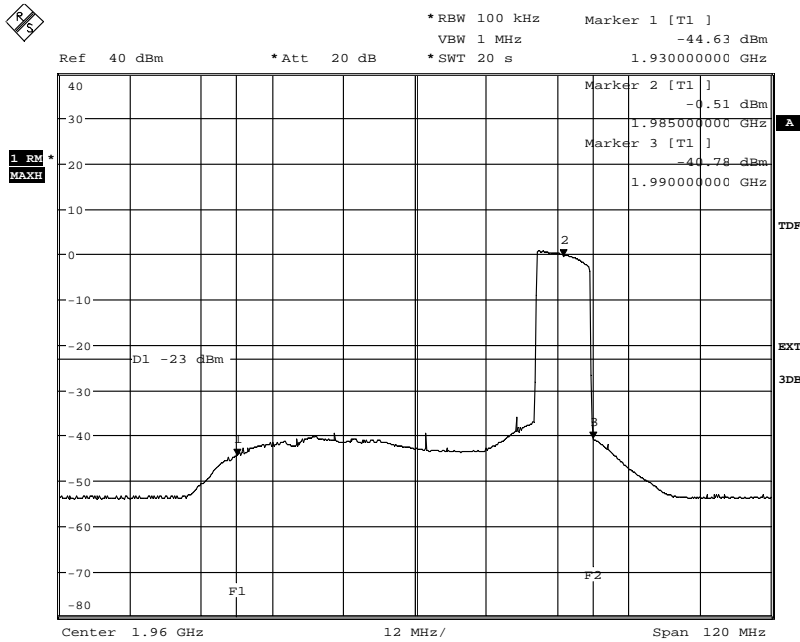

Date: 20.JAN.2015 09:23:09

Appendix 6

Diagram 9 c:

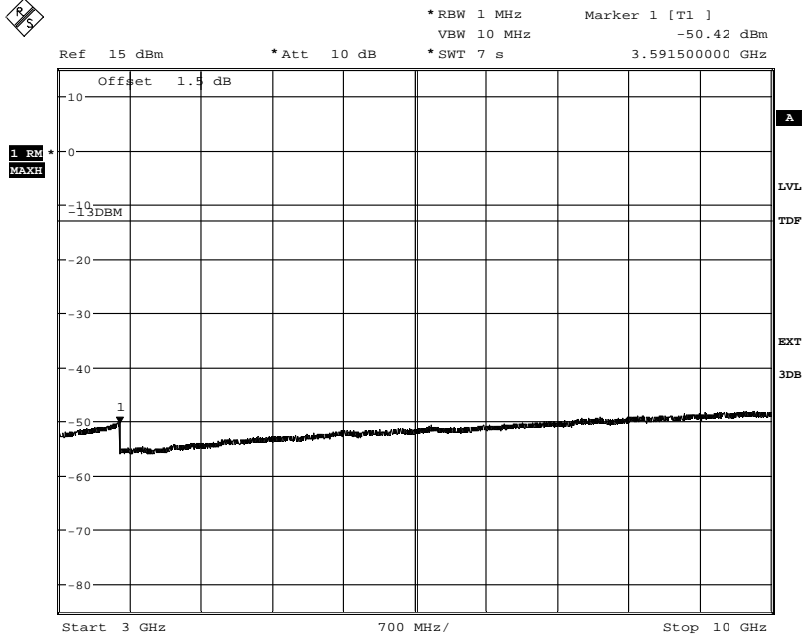

Date: 20.JAN.2015 09:25:29

Diagram 9 d:

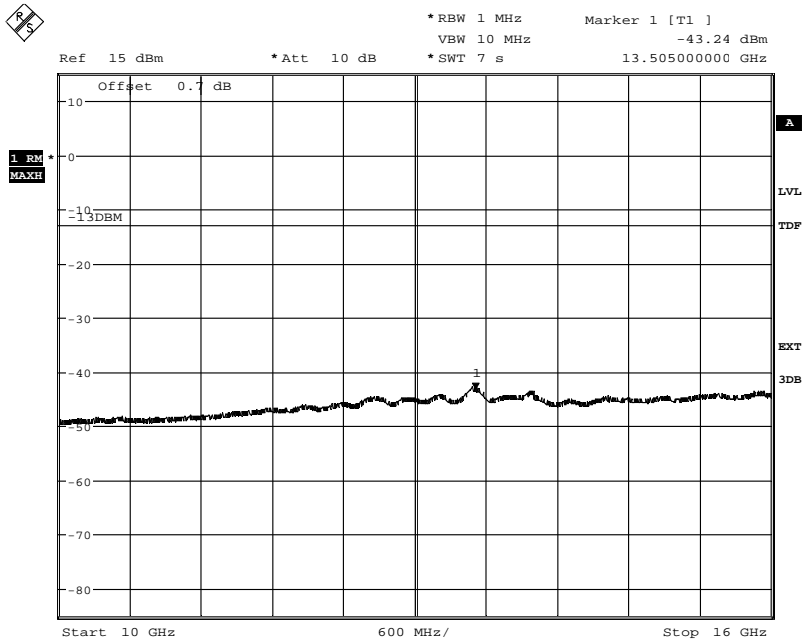

Date: 20.JAN.2015 09:27:06

Appendix 6

Diagram 9 e:

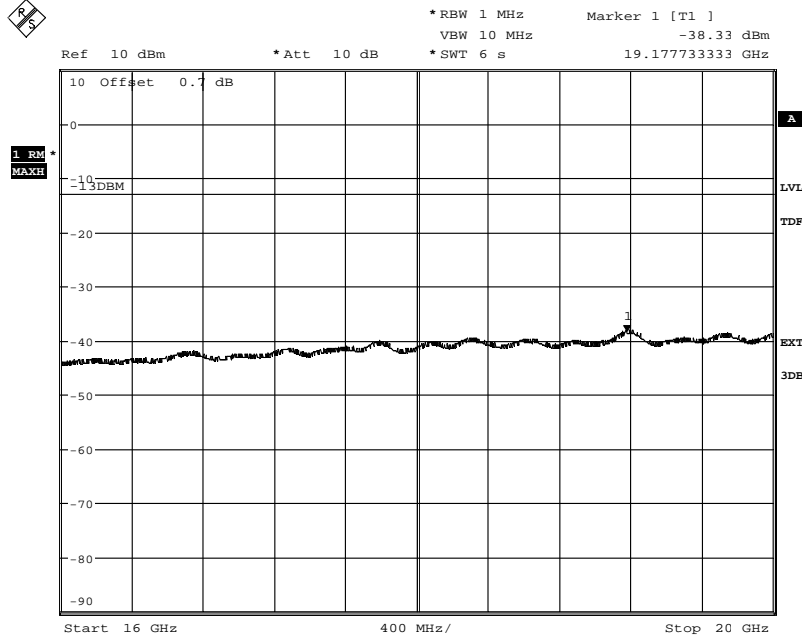

Date: 20.JAN.2015 09:31:49

Appendix 6

Diagram 10 a:

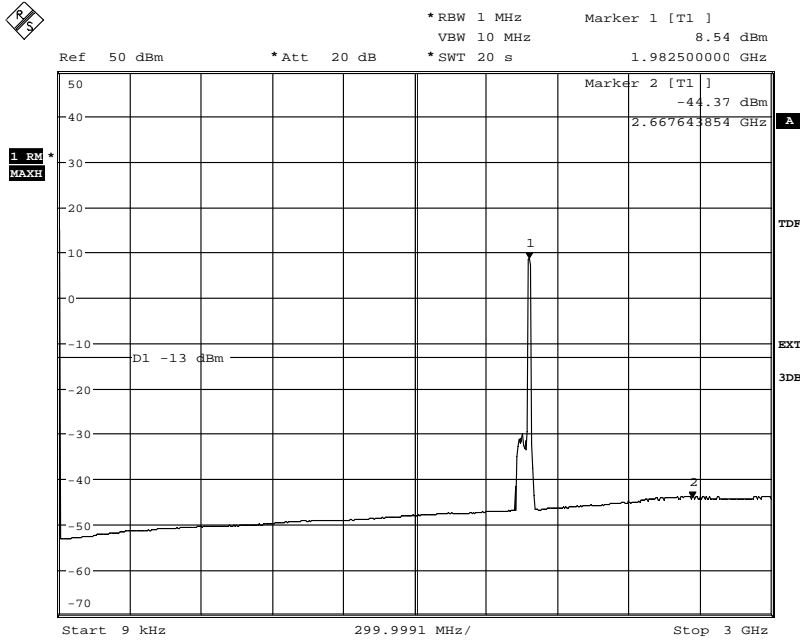

Date: 21.JAN.2015 09:46:03

Diagram 10 b:

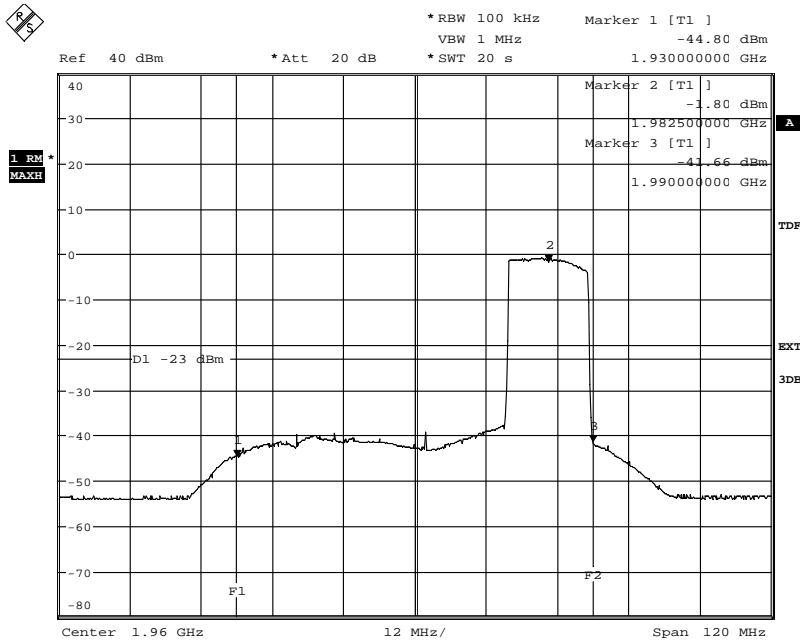

Date: 20.JAN.2015 09:46:14

Appendix 6

Diagram 10 c:

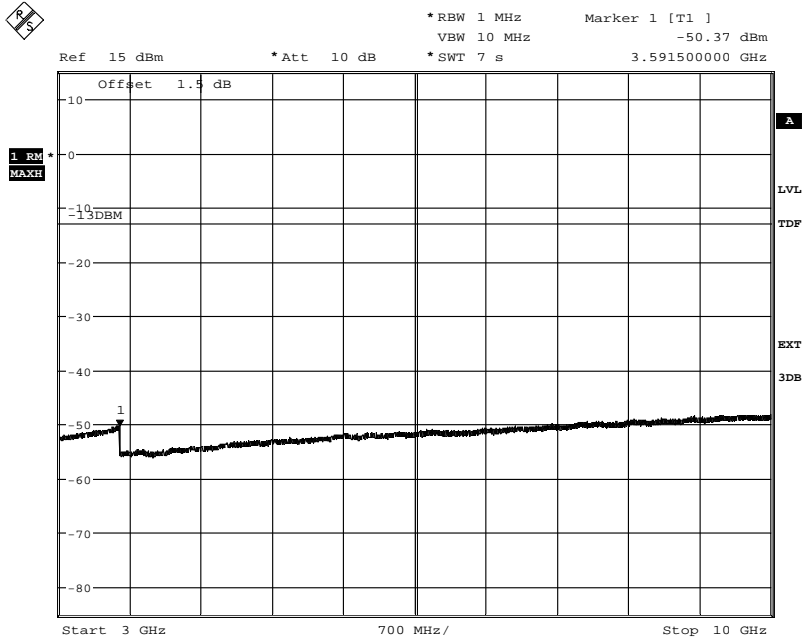

Date: 20.JAN.2015 09:36:08

Diagram 10 d:

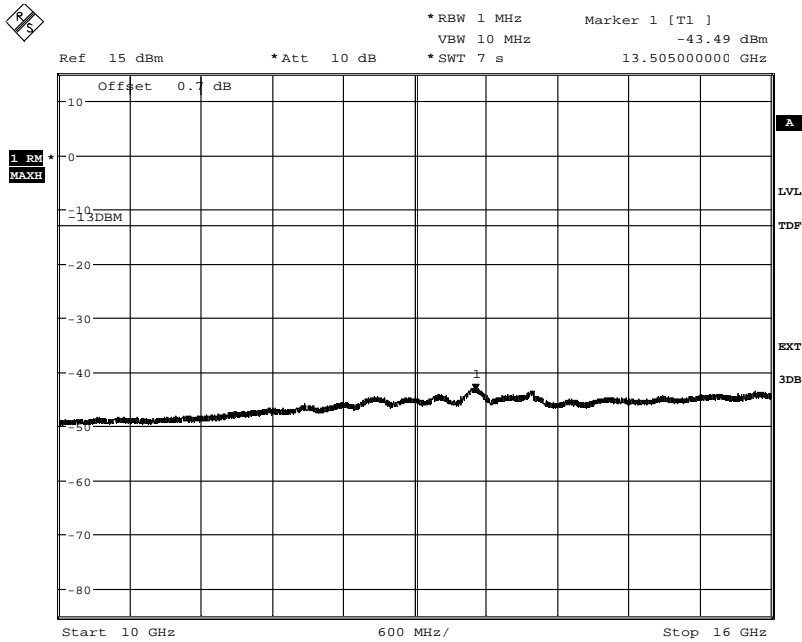

Date: 20.JAN.2015 09:34:27

Appendix 6

Diagram 10 e:

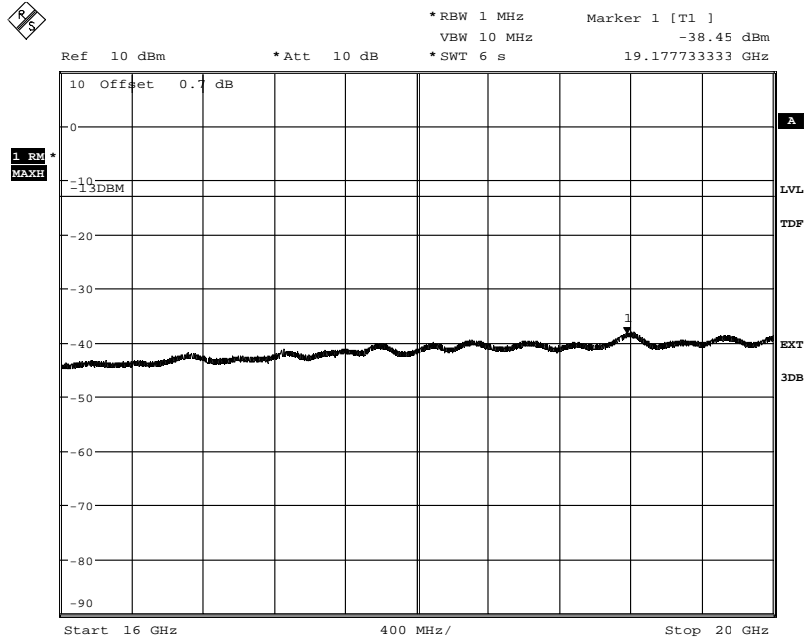

Date: 20.JAN.2015 09:33:21

Appendix 6

Diagram 11 a:

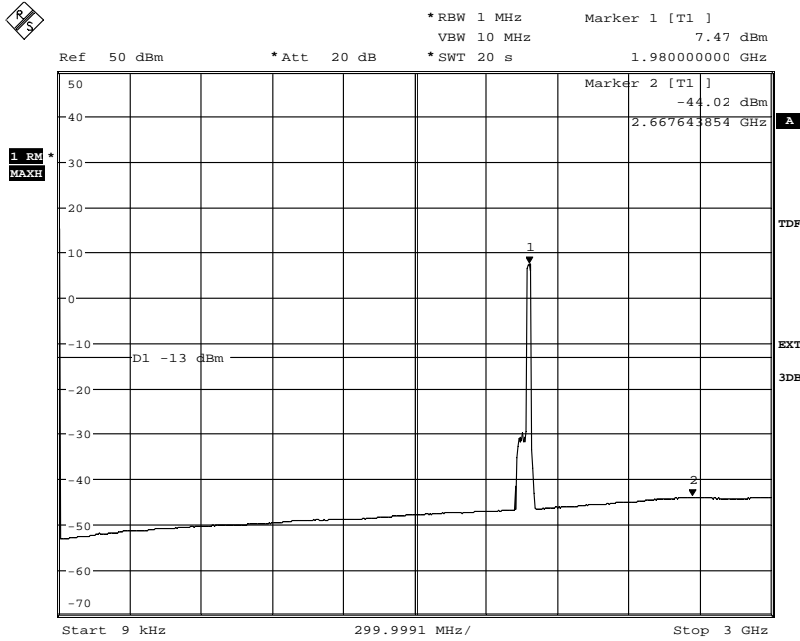

Date: 21.JAN.2015 09:48:21

Diagram 11 b:

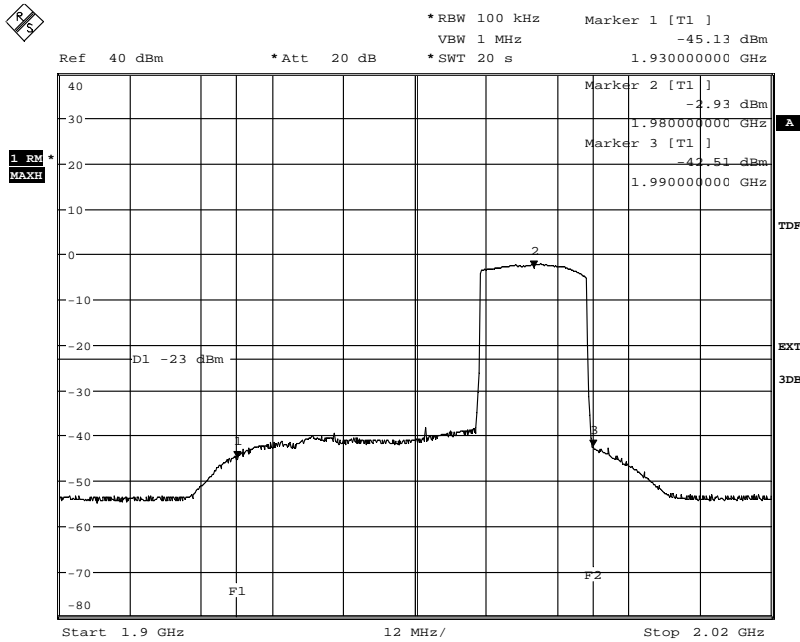

Date: 20.JAN.2015 09:49:19

Appendix 6

Diagram 11 c:

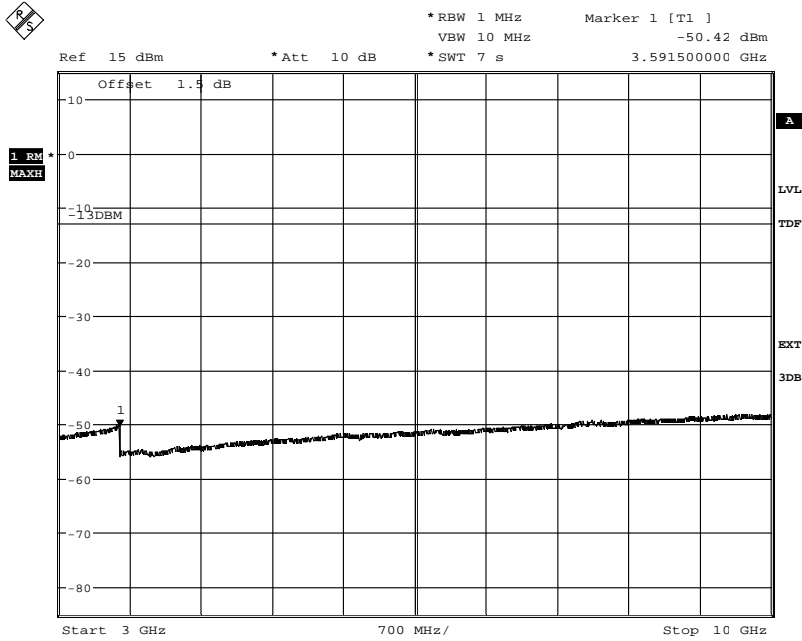

Date: 20.JAN.2015 09:38:20

Diagram 11 d:

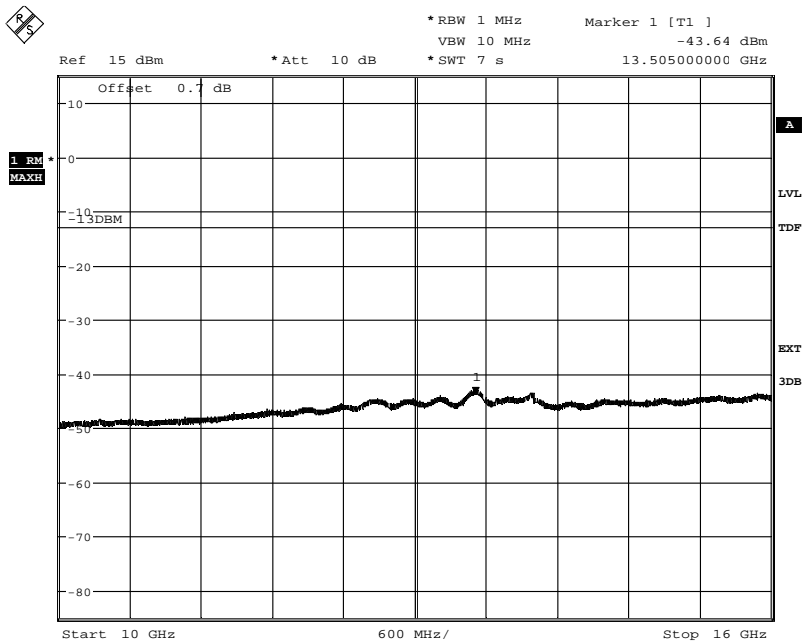

Date: 20.JAN.2015 09:39:17

Appendix 6

Diagram 11 e:

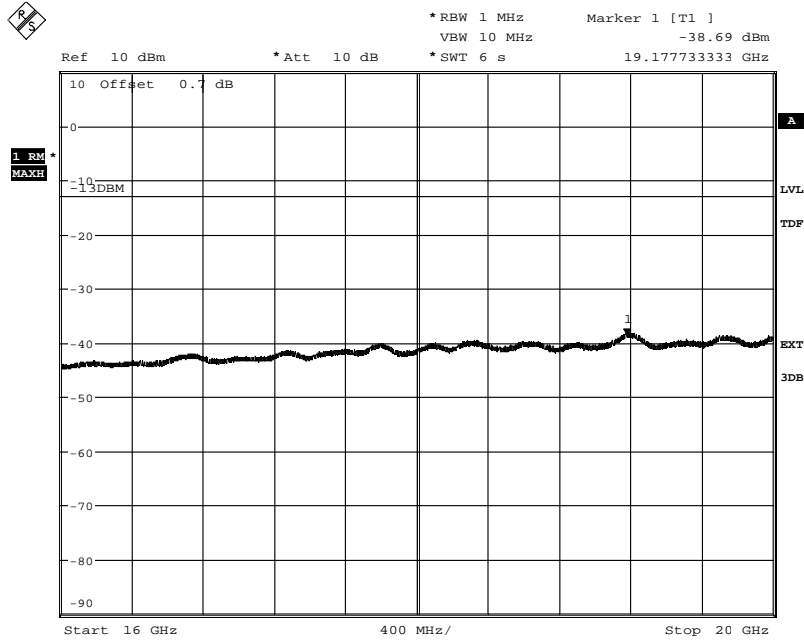

Date: 20.JAN.2015 09:40:33

Appendix 6

Diagram 12 a:

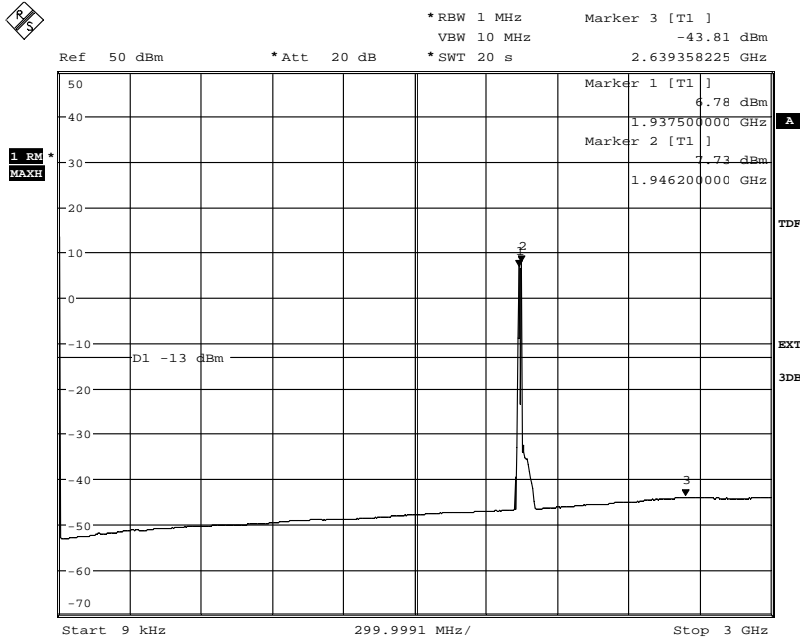

Date: 23.JAN.2015 07:40:21

Diagram 12 b:

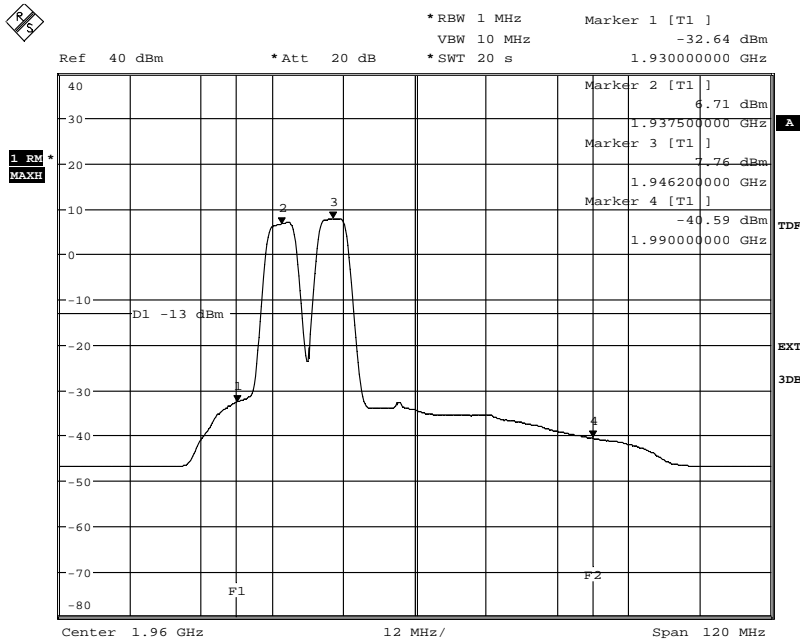

Date: 23.JAN.2015 07:38:17

Appendix 6

Diagram 12 c:

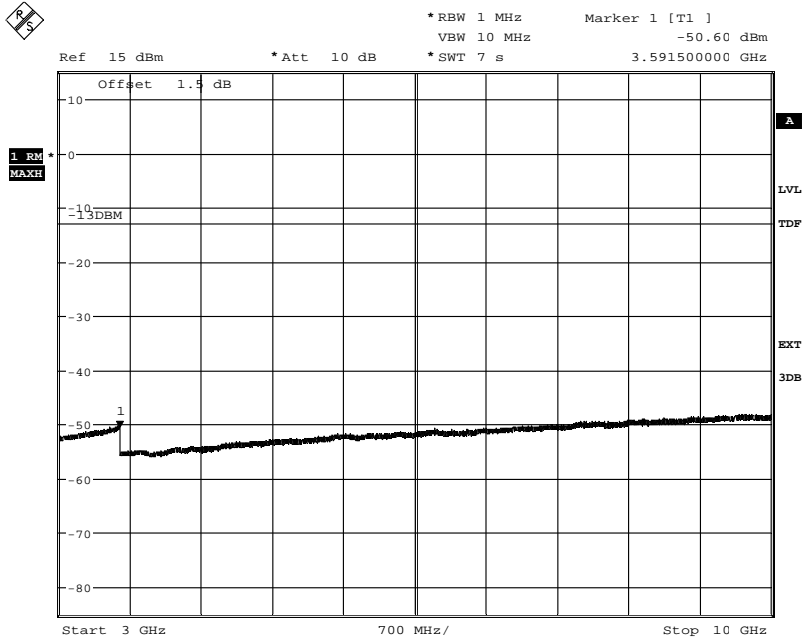

Date: 23.JAN.2015 07:42:15

Diagram 12 d:

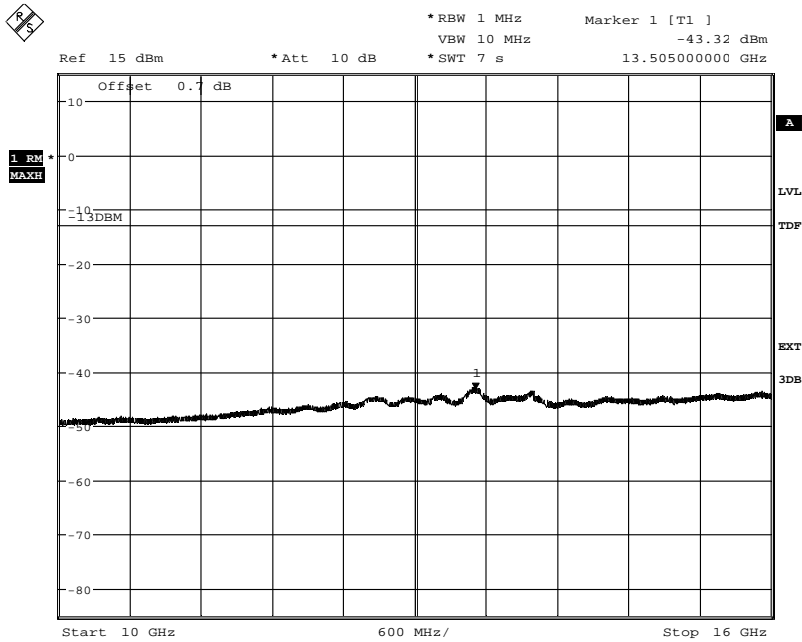

Date: 23.JAN.2015 07:48:01

Appendix 6

Diagram 12 e:

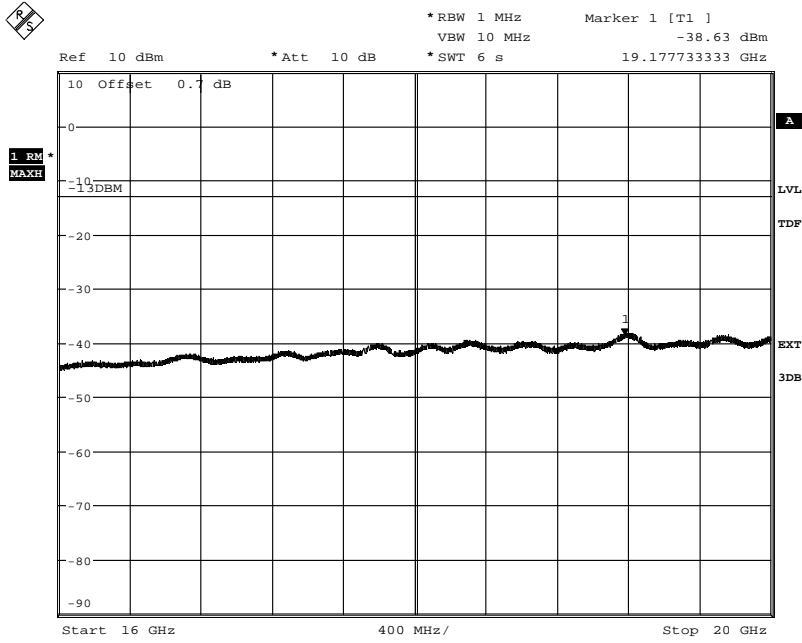

Date: 23.JAN.2015 07:48:58

Appendix 6

Diagram 13 a:

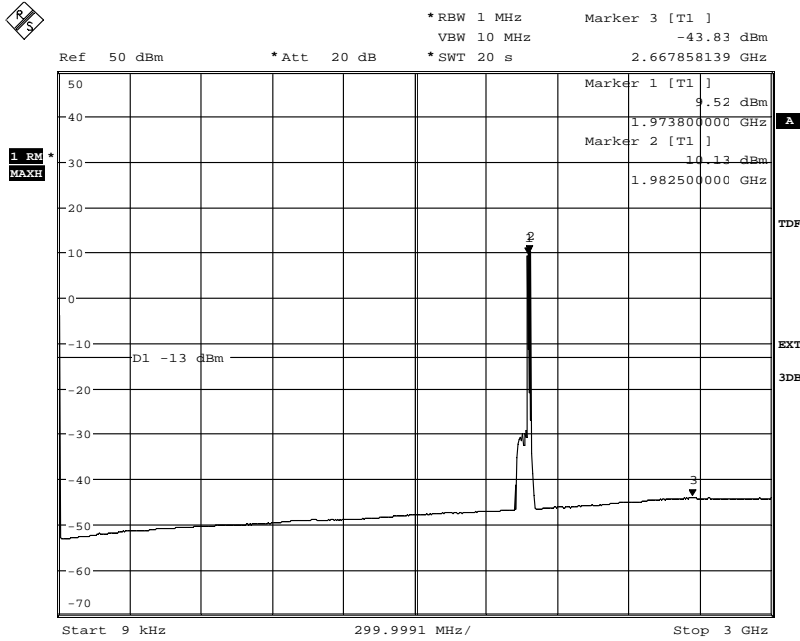

Date: 23.JAN.2015 07:57:44

Diagram 13 b:

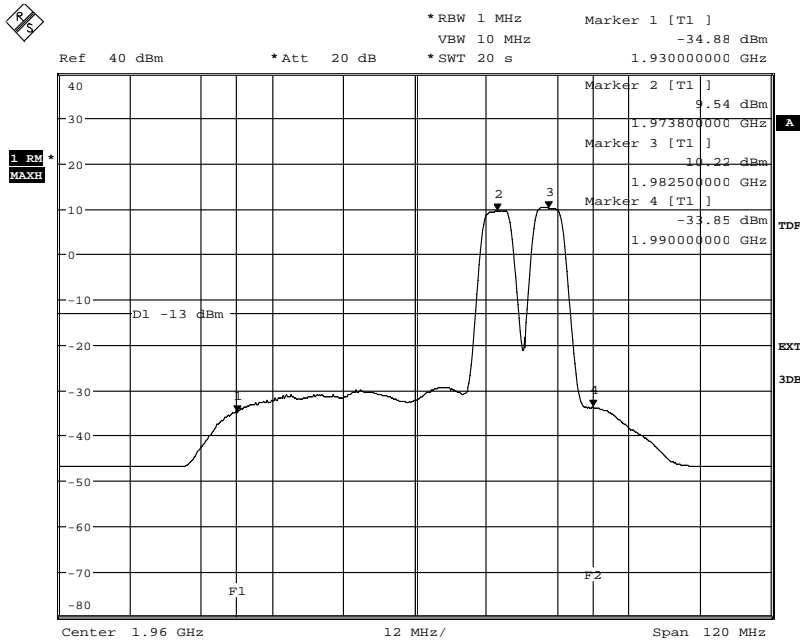

Date: 23.JAN.2015 07:56:18

Appendix 6

Diagram 13 c:

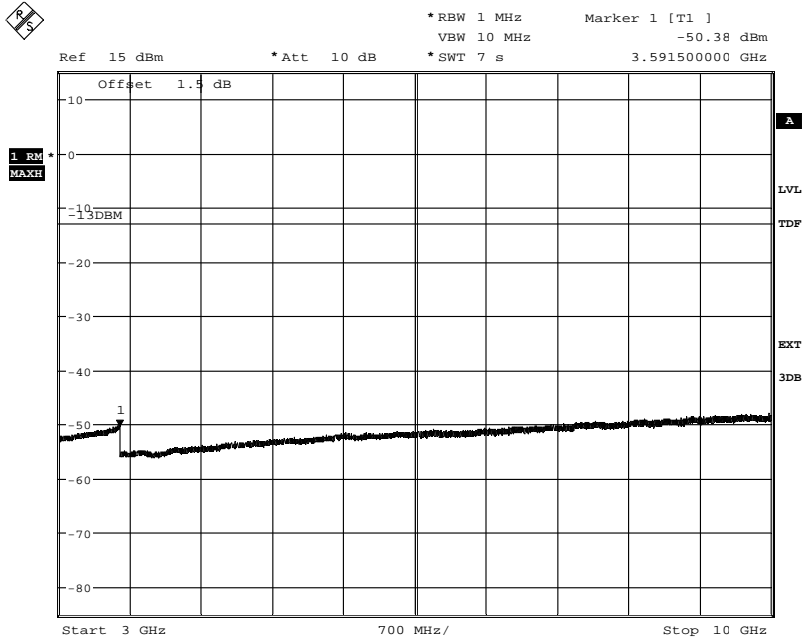

Date: 23.JAN.2015 07:53:05

Diagram 13 d:

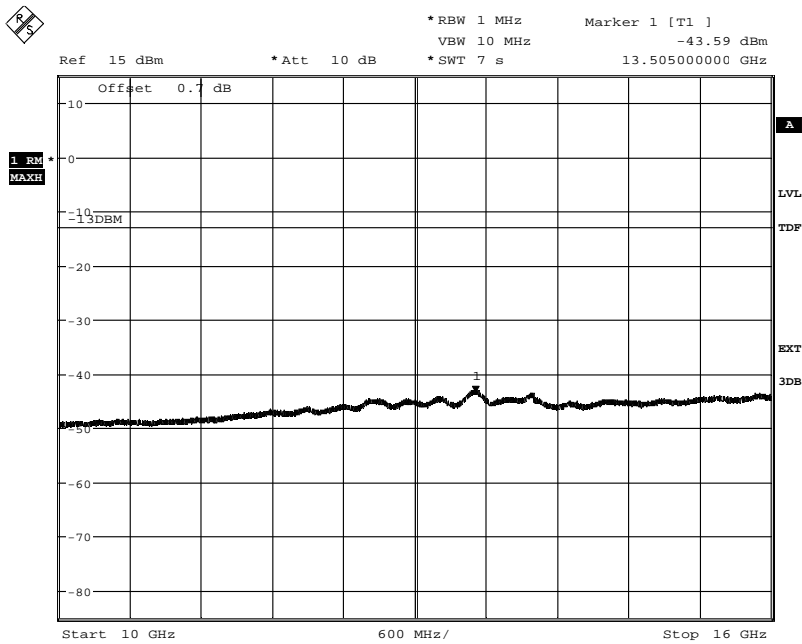

Date: 23.JAN.2015 07:51:57

Appendix 6

Diagram 13 e:

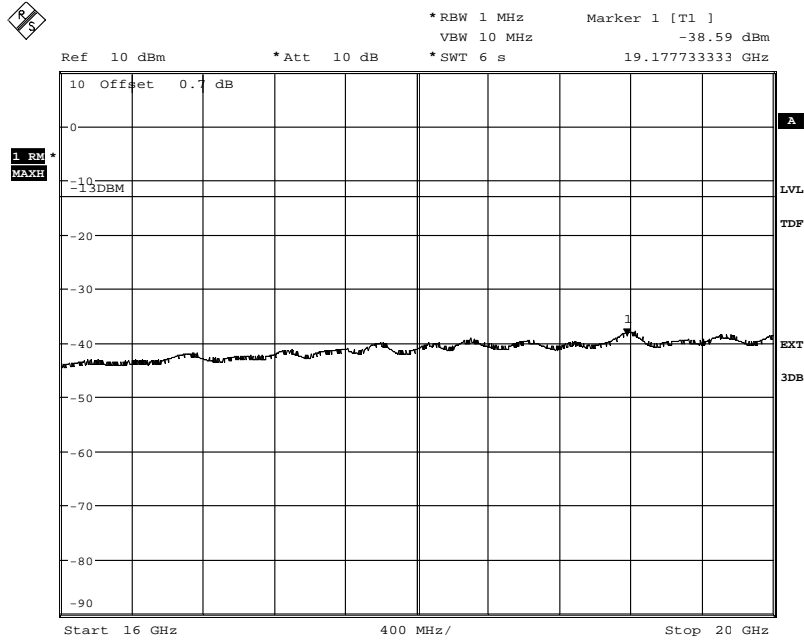

Date: 23.JAN.2015 07:50:50

Appendix 6

Diagram 14 a:

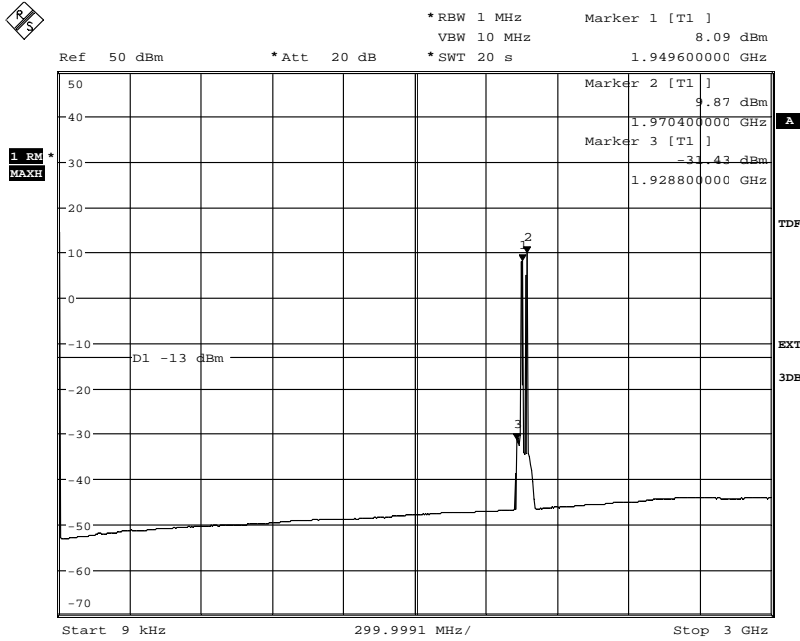

Date: 23.JAN.2015 08:17:51

Diagram 14 b:

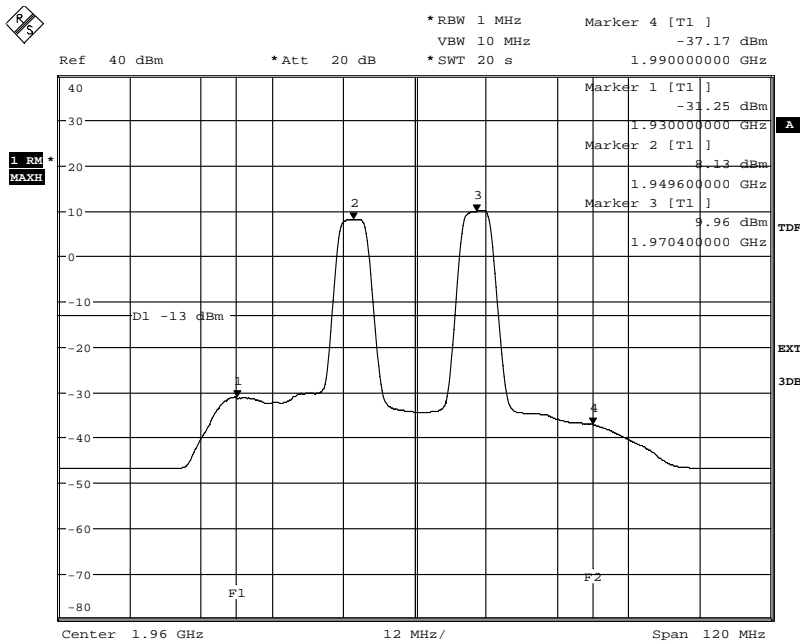

Date: 23.JAN.2015 08:12:58

Appendix 6

Diagram 14 c:

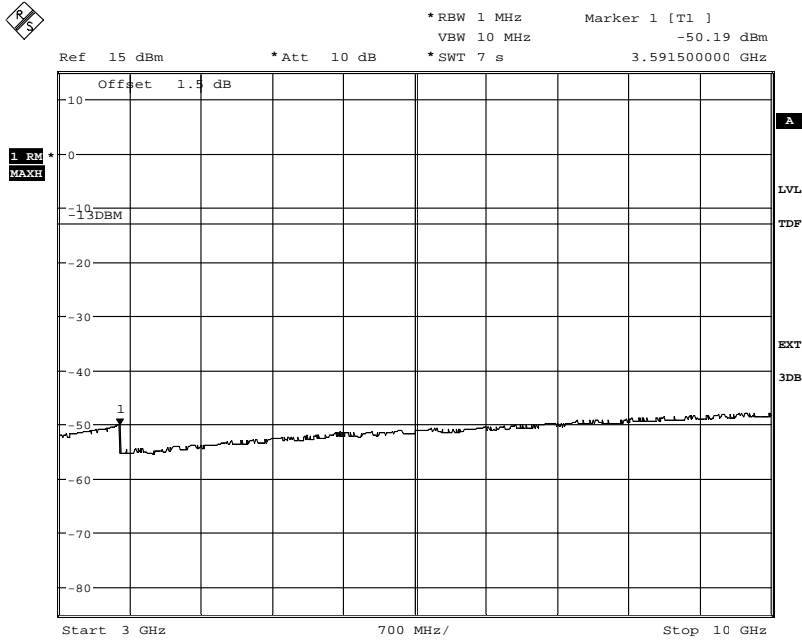

Date: 23.JAN.2015 08:33:49

Diagram 14 d:

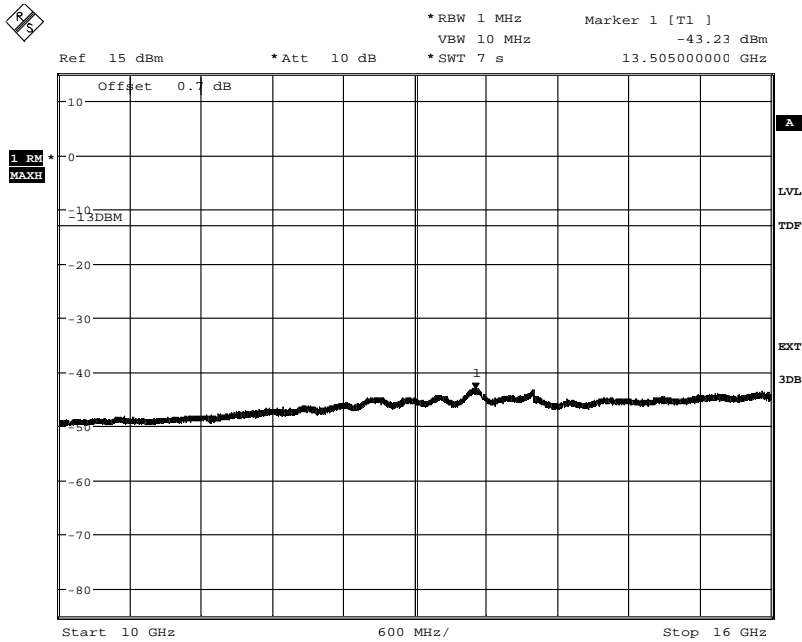

Date: 23.JAN.2015 08:34:56

Appendix 6

Diagram 14 e:

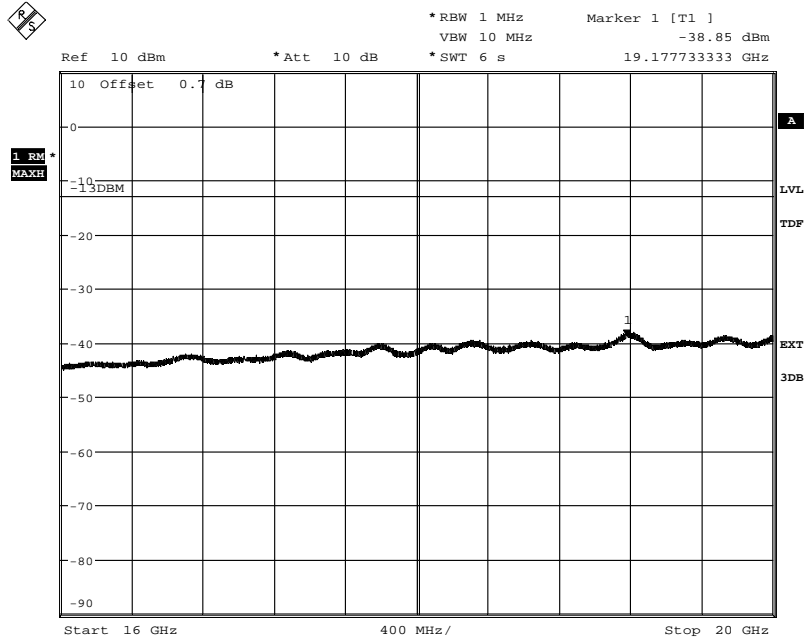

Date: 23.JAN.2015 08:35:56

Appendix 6

Diagram 15 c:

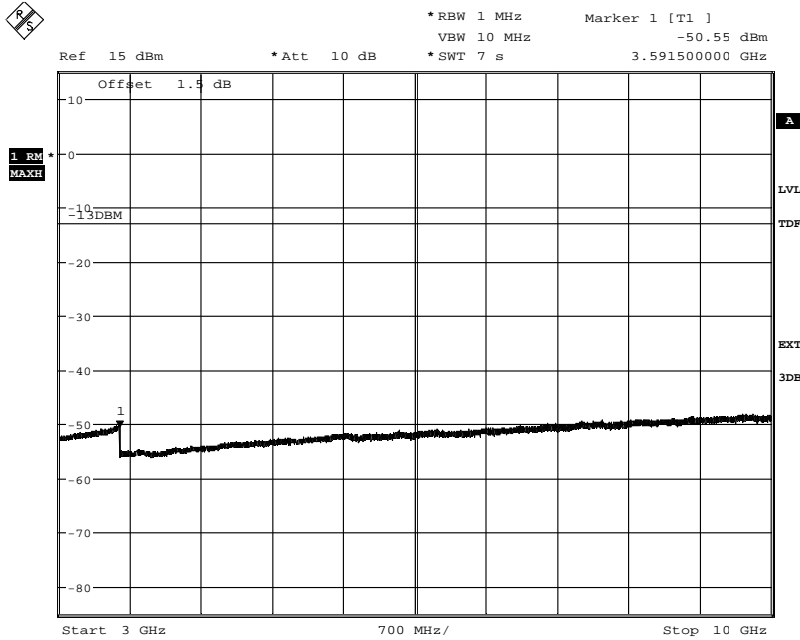

Date: 23.JAN.2015 08:49:56

Diagram 15 d:

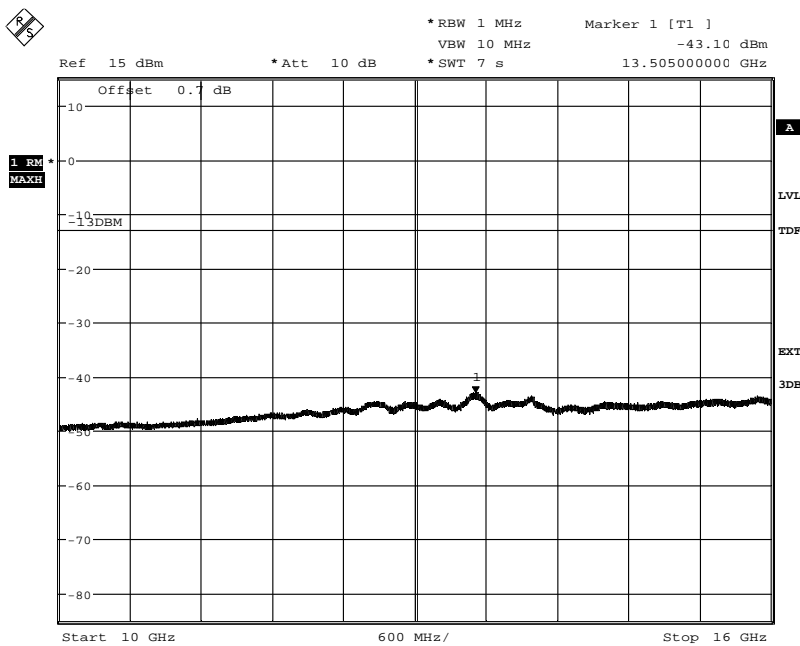

Date: 23.JAN.2015 08:49:00

Appendix 6

Diagram 15 e:

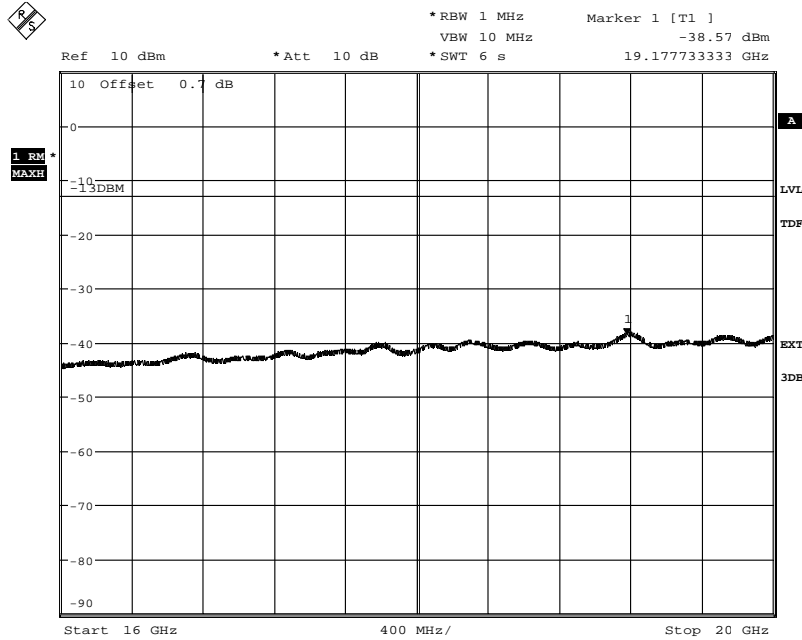

Date: 23.JAN.2015 08:47:36

Appendix 6

Diagram 16a:

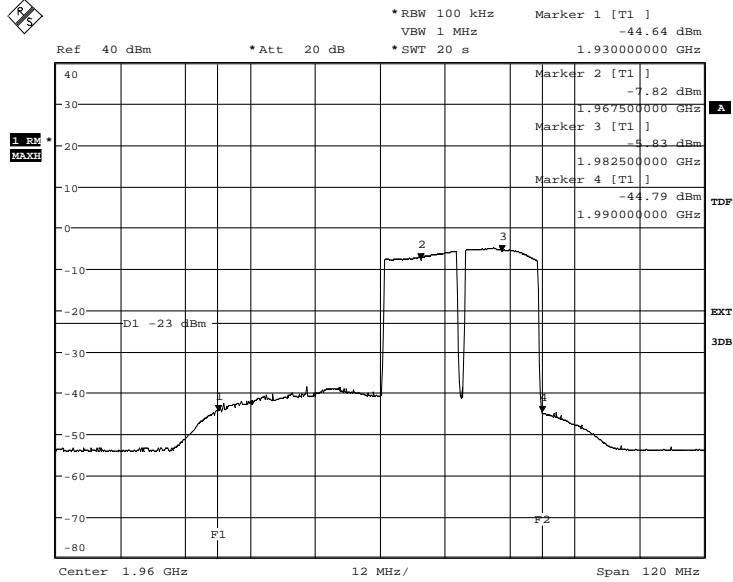

Date: 23.JAN.2015 10:43:46

Diagram 17 a:

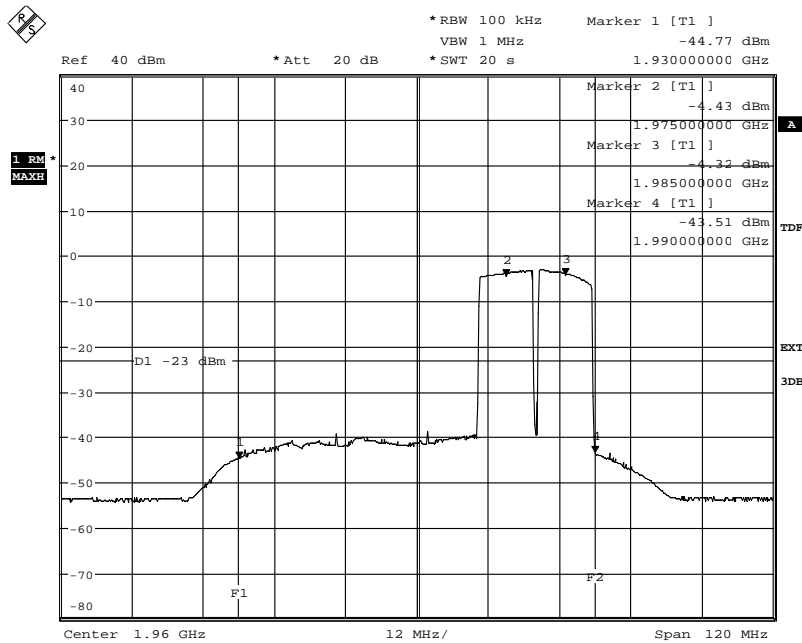

Date: 23.JAN.2015 10:47:56

Appendix 6

Diagram 18 a:

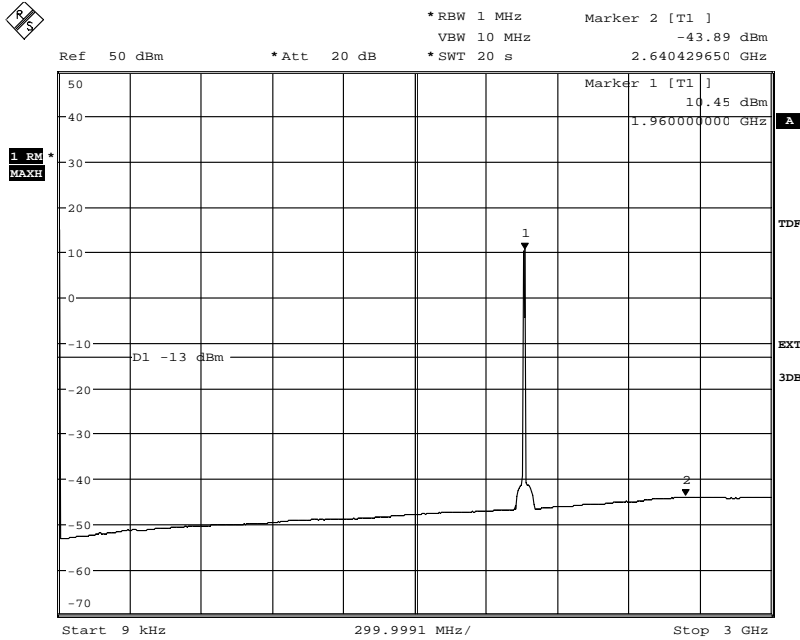

Date: 22.JAN.2015 15:11:38

Diagram 18 b:

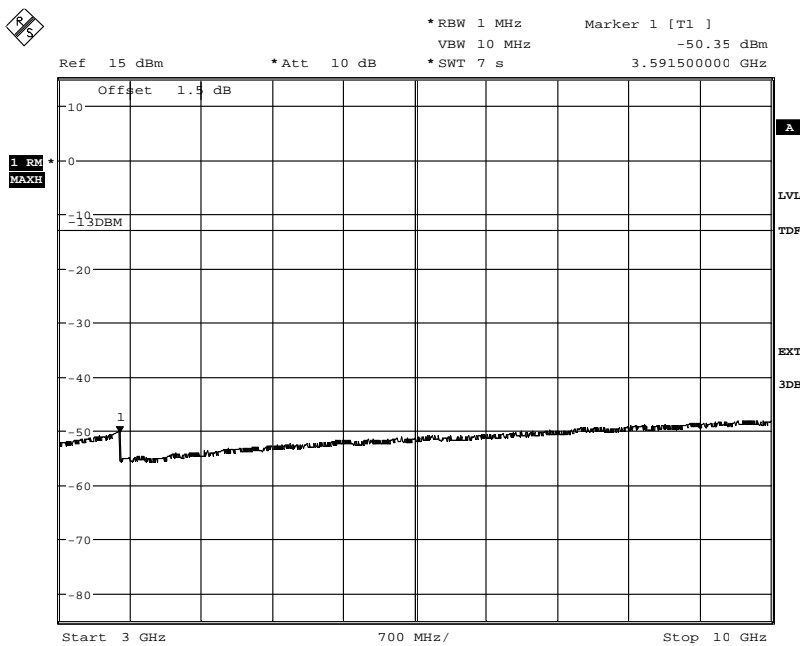

Date: 22.JAN.2015 15:14:21

Appendix 6

Diagram 18 c:

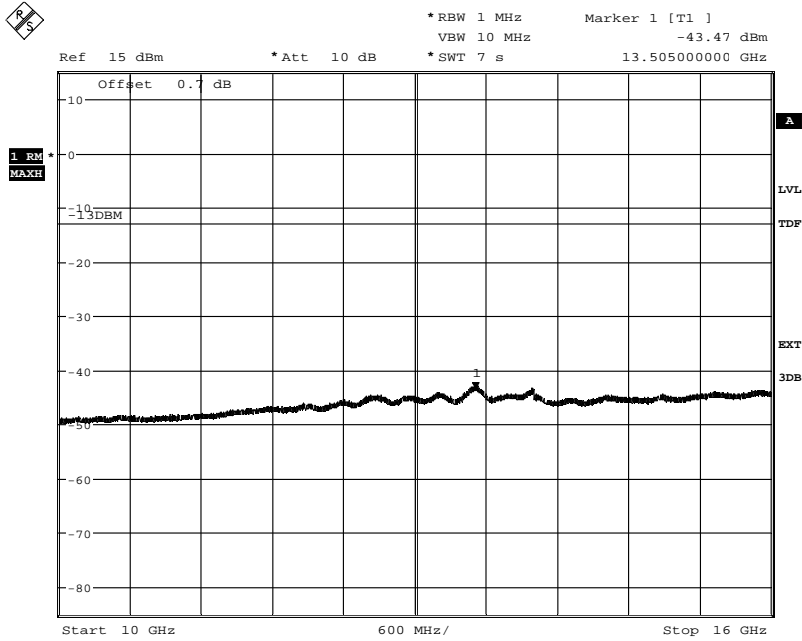

Date: 22.JAN.2015 15:15:33

Diagram 18 d:

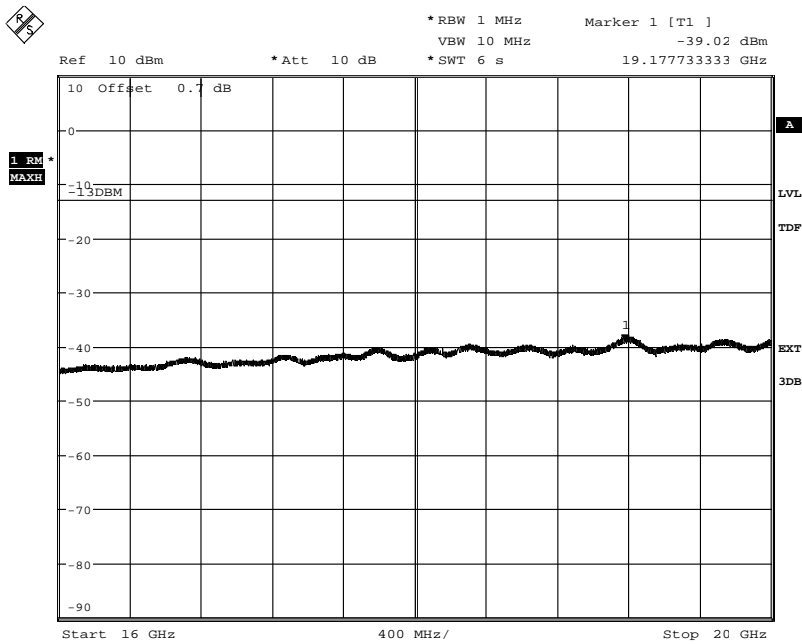

Date: 22.JAN.2015 15:16:50

Appendix 6

Diagram 19 a:

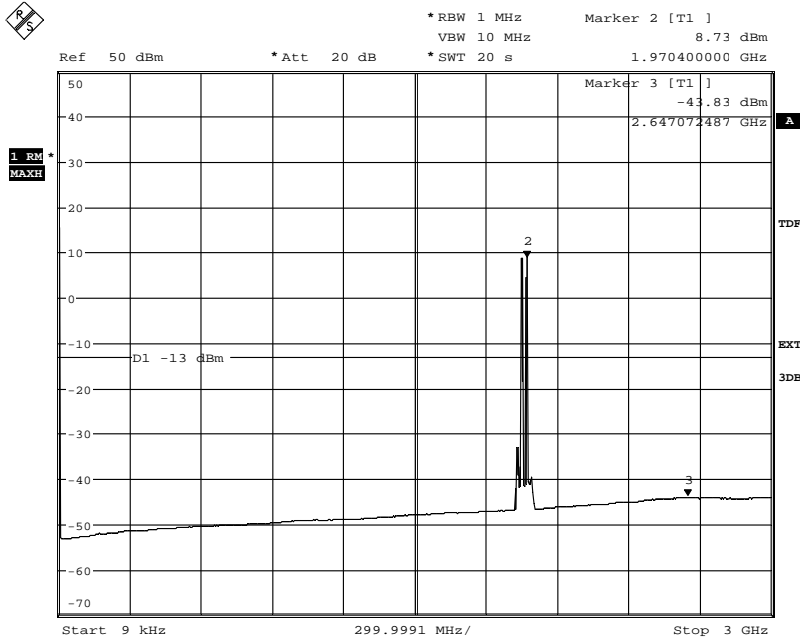

Date: 26.JAN.2015 09:57:05

Diagram 19 b:

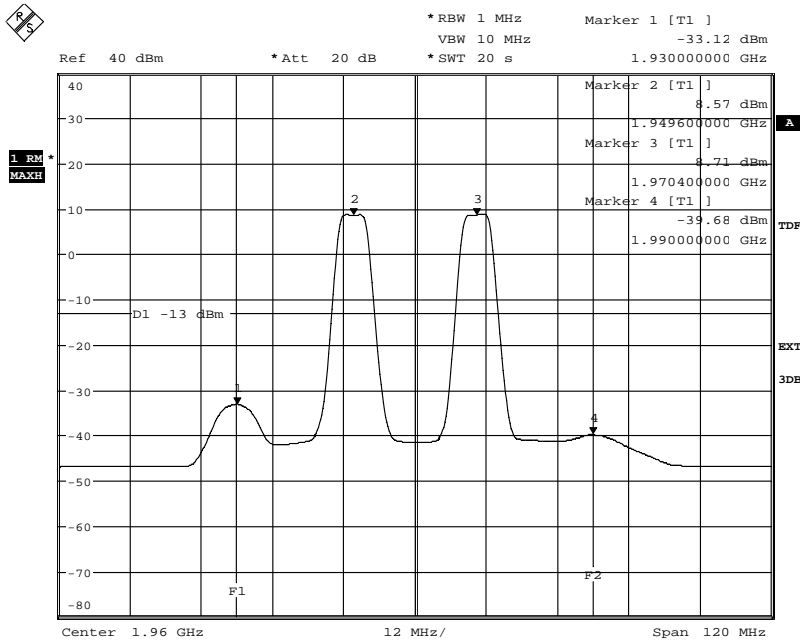

Date: 26.JAN.2015 09:55:24

Appendix 6

Diagram 19 c:

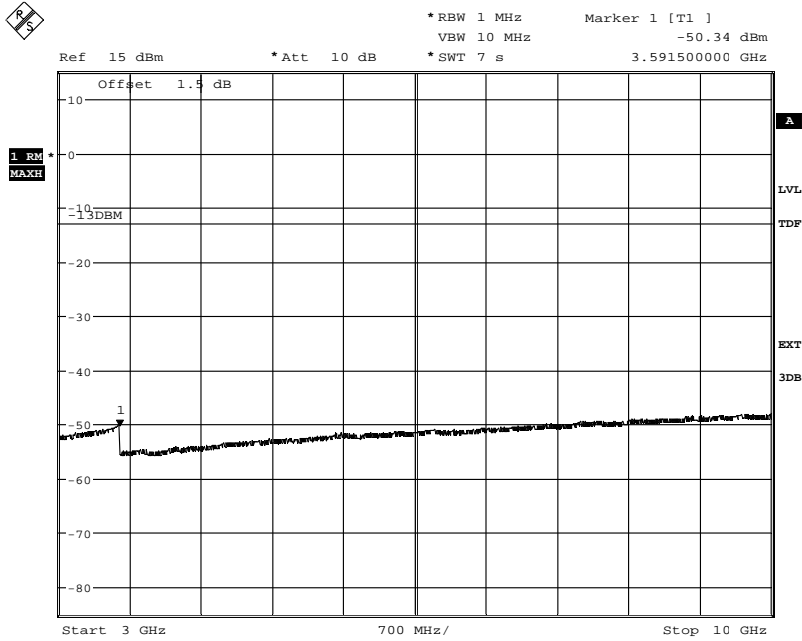

Date: 26.JAN.2015 09:53:04

Diagram 19 d:

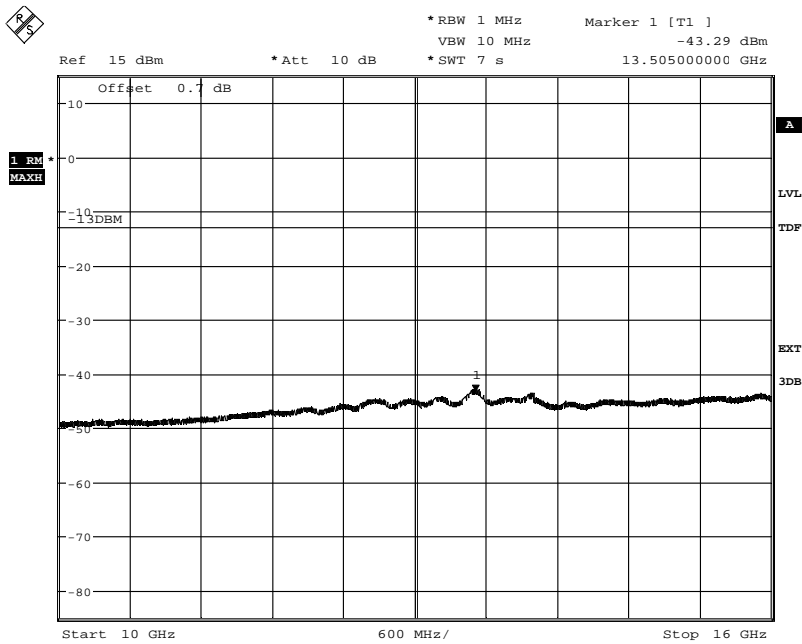

Date: 26.JAN.2015 09:51:18

Appendix 6

Diagram 19 e:

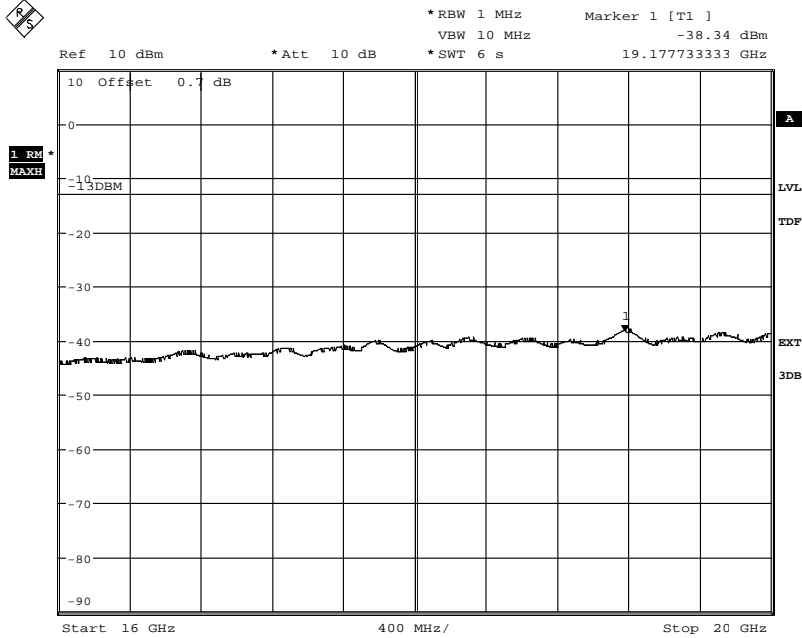

Date: 26.JAN.2015 09:49:50

Appendix 7

Field strength of spurious radiation measurements according to CFR 47 §24.238 / IC RSS-133 6.5

Date	Temperature	Humidity
2015-01-29	23 °C ± 3°C	24 % ± 5 %
2015-01-30	22 °C ± 3°C	27 % ± 5 %
2015-02-03	22 °C ± 3°C	18 % ± 5 %

Test set-up and procedure

The test sites are listed at FCC, Columbia with registration number: 93866. The test site complies with RSS-Gen, Industry Canada file no. 3482A-1.

The measurements were performed with both horizontal and vertical polarization of the antenna. The antenna distance was 3 m in the frequency range 30 MHz – 18 GHz and 1m in the frequency range 18 – 20 GHz.

In the frequency range 30 MHz – 20 GHz the measurement was performed in power with a RBW of 1 MHz. A propagation loss in free space was calculated. The used formula was

$$\gamma = 20 \log \left(\frac{4\pi D}{\lambda} \right), \gamma \text{ is the propagation loss and } D \text{ is the antenna distance.}$$

The measurement procedure was as the following:

1. The pre-measurement was first performed with peak detector. The EUT was measured in eight directions and with the antenna at three heights, 1.0 m, 1.5 m and 2.0 m.
2. Spurious radiation on frequencies closer than 20 dB to the limit in the pre-measurement is scanned 0-360 degrees and the antenna is scanned 1- 4 m for maximum response. The emission is then measured with the RMS detector and the RMS value is reported. Frequencies closer than 10 dB to the limit when measured with the RMS detector were measured with the substitution method according ANSI/TIA-603-C.

Appendix 7

The test set-up during the spurious radiation measurements is shown in the picture below:



Measurement equipment

Measurement equipment	SP number
Semi anechoic chamber	503 881
R&S ESU 26	901 553
EMC32 ver. 9.15.0	503 899
Chase Bilog Antenna CBL 6111A	503 182
EMCO Horn Antenna 3115	502 175
Flann STD Gain Horn Antenna 16-240	503 939
Flann STD Gain Horn Antenna 18-240	503 900
Flann STD Gain Horn Antenna 20240-20	503 674
µComp Nordic, Low Noise Amplifier	901 545
Schwarzbeck BBV9742, Low Noise Amplifier	504 085
HP Filter 3-18 GHz	504 200
Temperature and humidity meter, Testo 625	504 188

Appendix 7

Tested configurations

Configuration: RDI Cable 200 m

Symbolic name	Bandwidth (MHz)
B	5
M	5,10,15 and 20
T	5
T2-5 ₂	5+5

Results, representing worst case, T2-5₂: Diagram 1 a-d

Frequency (MHz)	Spurious emission level (dBm)	
	Vertical	Horizontal
30-20 000	All emission > 20 dB below limit	All emission > 20 dB below limit

Measurement uncertainty:

3.2 dB up to 18 GHz, 3.1 dB above 18 GHz

Limits

CFR 47 §24.238 and RSS-133 6.5

Outside a licensee's frequency band(s) of operation the power of any emission shall be attenuated below the transmitter power (P) by at least $43 + 10 \log (P)$ dB, resulting in a limit of -13 dBm per 1 MHz RBW.

Complies?	Yes
-----------	-----

Appendix 7

Diagram 1 a:

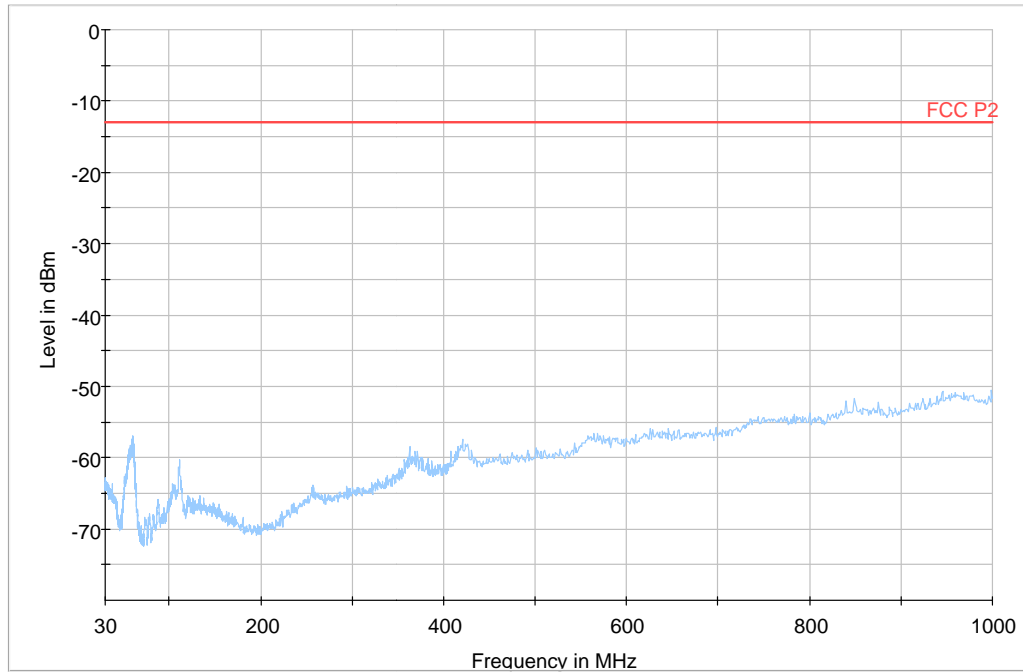
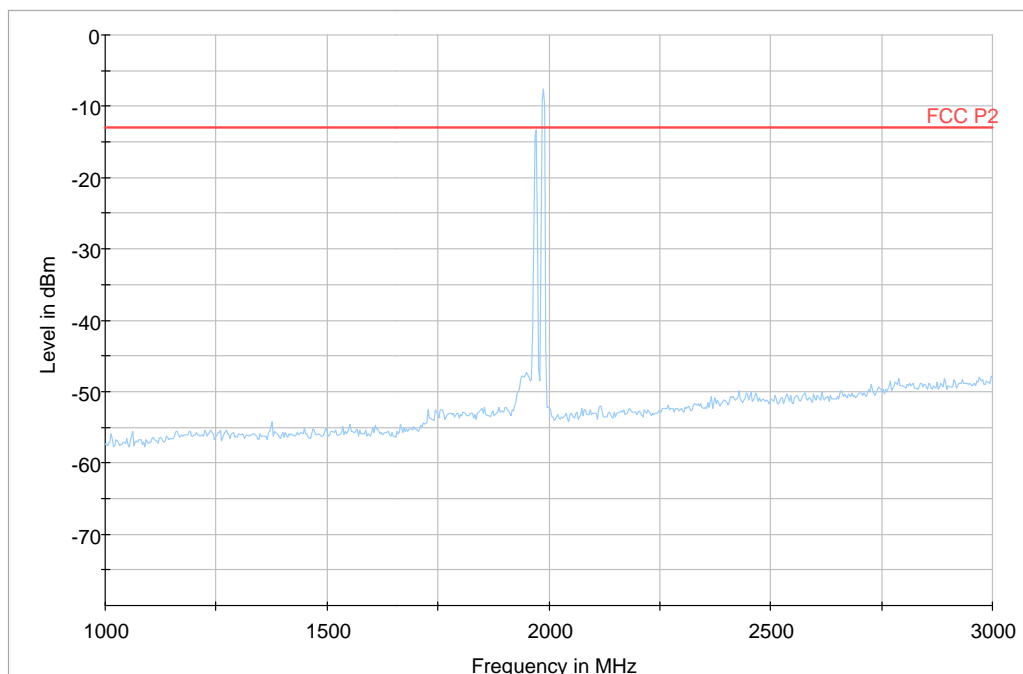

Diagram 1 b:



Note: The emission at 1970.0 and 1987.5 MHz are the carrier frequencies and shall be ignored in the context.

Appendix 7

Diagram 1 c:

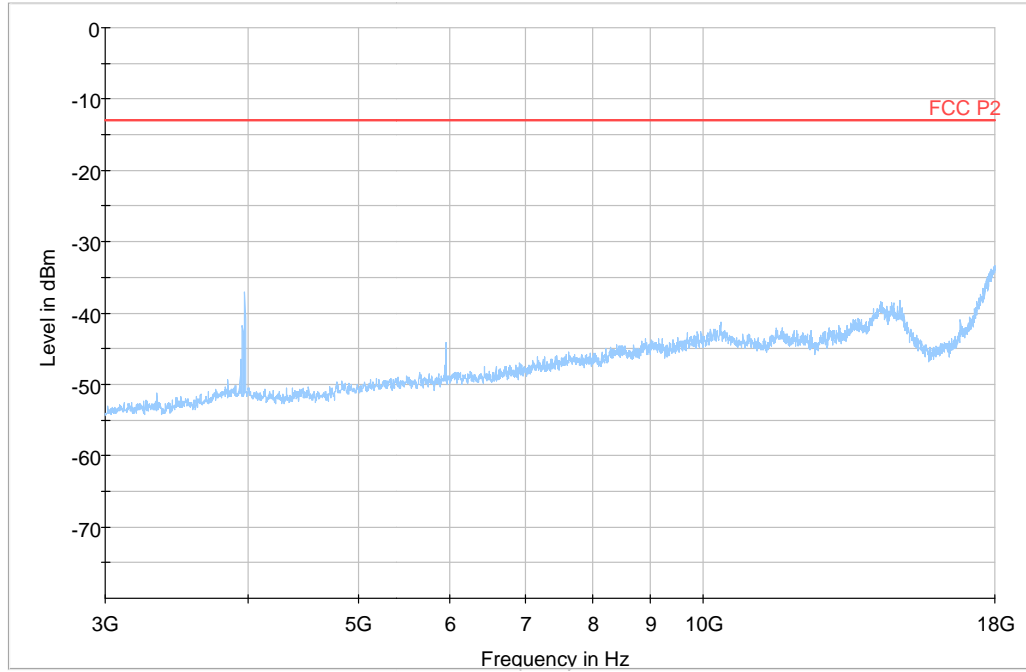
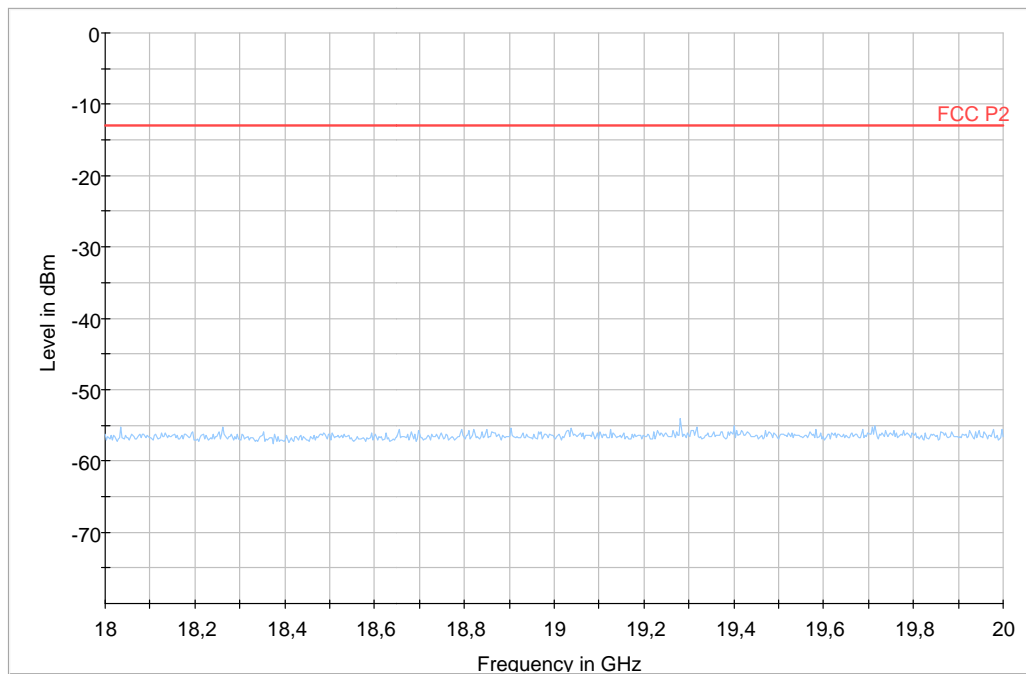

Diagram 1 d:



Appendix 8

Frequency stability measurements according to CFR 47 §24.235 / IC RSS 133 6.3

Date 2014-02-05 to 2014-02-09	Temperature (test equipment) 21-22 °C ± 3 °C	Humidity (test equipment) 25-29 % ± 5 %
----------------------------------	---	--

Test set-up and procedure

The measurement was made per 3GPP TS 36.141. The output was connected to a spectrum analyser. The spectrum analyser was connected to an external 10 MHz reference standard during the measurements.

The measurement was also made using a resolution bandwidth of 1% of the emission bandwidth, a reference point at the unwanted emission level which complies with the attenuation of $43 + 10 \log_{10} p$ (watts) (i.e. -13dBm) (for MIMO -16dBm) at the band edge of the lowest and highest channel was selected, and the frequency at these points was recorded as fL and fH respectively.

Measurement equipment	SP number
Rohde & Schwarz signal analyzer FSQ 40	504 143
RF attenuator	900 691
Testo 635, Temperature and humidity meter	504 203
Temperature cabinet	503 360

Appendix 8

Results

Nominal transmitter frequency was 1960.0 MHz (M) with a bandwidth of 5 MHz. Rated output power level at connector RF A (maximum): 17 dBm.

Configuration: RDI Cable 200 m

Test conditions		Frequency error (Hz)
Supply voltage DC (V)	Temp. (°C)	
-48.0	+20	+10
-55.2	+20	-11
-40.8	+20	+11
-48.0	+30	+12
-48.0	+40	+10
-48.0	+50	+14
-48.0	+10	+11
-48.0	0	+10
-48.0	-10	Not possible to activate transmitter
Maximum freq. error (Hz)		14
Measurement uncertainty		$< \pm 1 \times 10^{-7}$

Appendix 8

Configuration: RDI Cable 200 m

Test conditions			Frequency margin to band edge at -16dBm			
Supply voltage DC [V]	Temp [°C].	Carrier Bandwidth [MHz]	Test frequency Symbolic name Bottom		Test frequency Symbolic name Top	
			fL [MHz]	Offset to lower band edge (1930 MHz) [kHz]	fH [MHz]	Offset to upper band edge (1990 MHz) [kHz]
-48.0	+20	5	1930.212	212.0	1989.793	207.0
-48.0	+20	20	1930.856	856.0	1989.171	829.0

The frequency error results clearly shows that the frequency stability is good enough to ensure that the transmitted carrier stay within the operating band.

Remark

It was deemed sufficient to test a limited combination of TX frequencies, channel bandwidths configurations with one test model (modulation), as all combinations share a common internal reference to derive the TX frequency from.

Limits

§24.235

The frequency stability shall be sufficient to ensure that the fundamental emission stays within the authorized frequency block.

RSS-133 6.3 Frequency stability:

The carrier frequency shall not depart from the reference frequency in excess of ± 1.0 ppm (± 1960 Hz) for base stations when tested to the temperature and supply voltage variations specified in RSS-Gen.

Complies?	Yes
-----------	-----

Appendix 9

External photos

Top side



Bottom side



Side



Label

