



 <p>Akkred. Nr 1761 Provning ISO/IEC 17025</p>	<p>Rapport utfärdad av ackrediterat provningslaboratorium <i>Test report issued by an Accredited Testing Laboratory</i></p>
---	--

EMF Test Report: Ericsson Street Macro 6701 B261 (FCC)

Document number:	GFTL-19:000819 Uen Rev B	Date of report:	2019-09-19
Testing laboratory:	Ericsson EMF Research Laboratory Ericsson AB SE-164 80 Stockholm Sweden	Company/Client:	Shigeru Kawabata Ericsson AB Mobilvägen 12 22 362, Lund Sweden
Tests performed by:	Paramananda Joshi	Dates of tests:	2019-07-03 to 2019-07-09 (Rev A) 2019-09-16 to 2019-09-18 (Rev B)
Manufacturer and market name(s) of device:	Ericsson Street Macro 6701 B261		
Testing has been performed in accordance with:	FCC OET Bulletin 65 IEC 62232:2017		
Test results:	RF exposure compliance boundaries (exclusion zones) related to the limits in FCC 47 CFR 1.1310 to be included in the Customer Product Information (CPI) for Ericsson Street Macro 6701 B261.		
Additional information:			
Signature:	Test Engineer  <hr/> Paramananda Joshi Senior Researcher paramananda.joshi@ericsson.com Tel: +46 10 711 00 06	Quality Manager  <hr/> Christer Törnevik Senior Expert – EMF and Health christer.tornevik@ericsson.com Tel: +46 10 714 12 35	

Summary of EMF Test Report¹

Equipment under test (EUT)

Product name	Street Macro 6701		
Product number	KRK 101 01/1 KRK 101 01/2 KRK 101 01/11 KRK 101 01/21		
Supported bands, Tx frequency range (GHz) and standards	B261	27.5 – 28.35	NR
Duplexing technology and fraction of downlink transmission time to total time	TDD (72.1 %)		
Exposure environment	General public/uncontrolled, Workers/controlled		
EIRP^{2,3} (dBm) and IEC 62232 installation class [4]	45.1, 48.1, 51.1 (Configuration Mode 1) 48.1, 51.1, 54.1 (Configuration Mode 2)	E100, E100, E+ E100, E+, E+	

Results

RF exposure compliance boundaries, outside of which the exposure is below the general public (GP) and workers (W) exposure limits, are listed below.

Dimensions of the box-shaped compliance boundary for general public (GP) and workers (W) exposure for Street Macro 6701 applicable in markets employing the FCC RF exposure limits for maximum output power with power tolerance and TDD downlink duty cycle included.

Mode and output power for Street Macro 6701							Dimensions of the box-shaped compliance boundary (m)							
							Distance in front of EUT		Width		Height		Distance behind EUT	
Band	Standard	Config Mode ⁴	Nominal total EIRP	Power tolerance	TDD DL duty cycle	Sector shapes	GP	W	GP	W	GP	W	GP	W
B261	NR	1	47 dBm	1.5 dB	72.1 %	Hotspot1	0.7	0.3	0.8	0.7	1.0	1.0	0.2	0.2
B261	NR	1, 2	50 dBm	1.5 dB	72.1 %	Hotspot1, Hotspot2, Macro3, Macro3b ⁵	0.9	0.4	1.1	0.7	1.0	1.0	0.2	0.2
B261	NR	1, 2	53 dBm	1.5 dB	72.1 %	Hotspot1, Hotspot2, Macro3, Macro3b	1.3	0.6	1.5	0.7	1.0	1.0	0.2	0.2
B261	NR	2	56 dBm	1.5 dB	72.1 %	Hotspot2, Macro3, Macro3b	1.8	0.8	2.1	1.0	1.0	1.0	0.2	0.2

For the power levels specified in the table which include tolerances, and the upward rounding of compliance boundary dimensions to the nearest decimeter, the specified results are conservative.

¹ This page contains a summary of the test results. The full report provides a complete description of all test details and results.

² The stated EIRP value is the maximum total EIRP without including power tolerance and is obtained using the antenna patterns provided by the client.

³ These values are provided for the lowest, the middle and the highest output power level in Table 3.

⁴ Configuration Mode

⁵ Sector shape Macro3 with a down-tilt of 7.5°.

1 General information

The test results presented in this report define compliance boundaries for Street Macro 6701 B261. Outside of these compliance boundaries, the radio frequency (RF) exposure levels are below the limits specified by the Federal Communications Commission (FCC) [1]. The tests were performed by calculations in accordance with the Ericsson RF exposure calculation procedure for base stations [2], which is in conformity with the FCC OET Bulletin 65 [3] and IEC 62232:2017 [4].

It should be noted that the test results presented in this test report are valid for the frequency range specified in Table 1, for the antenna properties specified in Table 2, and for the power level, the power tolerance and TDD downlink duty cycle specified in Table 3. These data as well as the applied antenna pattern files were supplied by the client and may affect the validity of the results.

Proposed EMF health and safety information for inclusion in the Customer Product Information (CPI) is provided in Appendices A, B and C.

2 Equipment under test

Tables 1 and 2 below summarize the technical data for the equipment under test (EUT) and the antenna properties for the integrated antenna. Table 3 lists the nominal total output power levels from the radio unit and the total time-averaged output power including output power tolerance and the TDD downlink duty cycle for Configuration Mode 1 and Configuration Mode 2. In Configuration Mode 1, the phased array antenna module (PAAM) of the product is divided into two halves, each containing 2 x 24 subarrays. In this configuration, the product can generate four beams, one for each array half and polarization. In Configuration Mode 2, the full array, containing 4 x 24 subarrays, can generate two beams, one for each polarization.

EMF compliance assessments were conducted for each configuration mode at the lowest, the middle and the highest output power level in Table 3.

The EUT related data in Tables 1-3 were supplied by the client.

Table 1 Technical data for the EUT.

Product name and product number	Street Macro 6701		KRK 101 01/1 KRK 101 01/2 KRK 101 01/11 KRK 101 01/21
Supported bands, Tx frequency range (GHz), and standards	B261	27.5 – 28.35	NR
Dimensions⁶, H x W x D (mm)	531 x 200 x 125		
Duplexing technology and fraction of downlink transmission time to total time	TDD (72.1 %)		
Exposure environment	General public/uncontrolled, Workers/controlled		
EIRP^{2,3} (dBm) and IEC 62232 installation class [4]	45.1, 48.1, 51.1 (Configuration Mode 1) 48.1, 51.1, 54.1 (Configuration Mode 2)		E100, E100, E+ E100, E+, E+

⁶ The dimensions of the EUT exclude mounting brackets.

Table 2 Properties of the integrated antenna.

Type	Phased Array Antenna Module (PAAM)
Number of antenna panels	2 (Configuration Mode 1) 1 (Configuration Mode 2)
Number of beams	4 (Configuration Mode 1) 2 (Configuration Mode 2)
Gain ⁷ (dBi)	25.6 (Configuration Mode 1) 28.6 (Configuration Mode 2)
EIRP ⁸ (dBm) per beam	41-47 in a step size of 1 dB (Configuration Mode 1) 47-53 in a step size of 1 dB (Configuration Mode 2)
Horizontal HPBW ⁹ (degrees)	4.1°
Vertical HPBW ⁹ (degrees)	20.9° (Configuration Mode 1) 10.4° (Configuration Mode 2)
Number of antenna elements (N_H, N_V) per antenna panel	(24, 4) (2 polarizations) for Configuration Mode 1 (24, 8) (2 polarizations) for Configuration Mode 2
Element separation distance (Δ_H, Δ_V) (mm)	(5.288, 6.406)
Maximum scan range in horizontal plane (degrees)	±60°
Maximum scan range in vertical plane (degrees)	±15°

Table 3 EUT configuration with nominal output power level and total power level including output power tolerance and TDD downlink duty cycle.

Band	Standard	Config Mode	Nominal total output power (dBm/W)	TDD downlink duty cycle	Power tolerance (dB)	Total time-averaged output power (dBm/W)
B261	NR	1, 2	21 / 0.125	72.1 %	1.5	21.1 / 0.128
B261	NR	1, 2	22 / 0.158	72.1 %	1.5	22.1 / 0.161
B261	NR	1, 2	23 / 0.200	72.1 %	1.5	23.1 / 0.203
B261	NR	1, 2	24 / 0.250	72.1 %	1.5	24.1 / 0.256
B261	NR	1, 2	25 / 0.316	72.1 %	1.5	25.1 / 0.322
B261	NR	1, 2	26 / 0.398	72.1 %	1.5	26.1 / 0.405
B261	NR	1, 2	27 / 0.500	72.1 %	1.5	27.1 / 0.510

3 Exposure conditions

The EUT is intended to be installed on walls, poles and similar structures making it possible to ensure that the general public has no access to the EMF compliance boundary. Other installation related exposure conditions are not reasonably foreseeable for the EUT.

The maximum TDD downlink duty cycle was considered to obtain the maximum time-averaged output power. Other factors such as beam scanning in elevation and azimuth, RBS utilization, and scheduling time are reasonably foreseeable and will significantly reduce the time-averaged power and the RF exposure. These factors were however not considered in this assessment, which adds to the conservativeness of the obtained compliance boundaries.

4 EMF compliance boundary calculations

The RF exposure was evaluated using calculations performed according to the Ericsson RF Exposure Calculation Procedure for Base Stations [2], which conforms to FCC OET Bulletin 65 [3] and IEC 62232 [4]. The calculations were made using the far-field spherical formula. The first step in calculating the compliance boundary was to use the spherical far-field formula to estimate power density:

$$S_{\text{sph}}(\theta, \phi) = \frac{P_a G(\theta, \phi)}{4\pi r^2},$$

⁷ The stated gain value is the maximum gain of antenna per panel obtained from the antenna patterns provided by the client .

⁸ The stated EIRP value is the nominal maximum value without power tolerance included.

⁹ The stated half-power beam widths are for broadside beam.

where S, P_a, G, r, θ , and ϕ denote the power density, the total time-averaged power accepted by antenna, the antenna gain, the distance from the antenna, and the angular variables in a spherical coordinate system, respectively. The total time-averaged power delivered to the antenna include tolerances and the TDD downlink duty cycle. The envelope of antenna gains for all possible traffic beams was obtained from far-field measurements provided by the client. Such envelope patterns were provided for two different frequencies, specifically 27.7 GHz and 28 GHz within Band 261.

There are different available coverage shapes of the beam envelope pattern depending on deployment scenarios (Hotspot1 for Configuration Mode 1, and Hotspot2, Macro3 and Macro3b⁵ for Configuration Mode 2). Maximum gain values, corresponding to the envelope patterns, were used in the above equation to estimate power density for each sector shape. The maximum gain value of the antenna considering all possible scan directions and sector shapes was found to be 25.6 dBi for Configuration Mode 1 and 28.6 dBi for Configuration Mode 2.

The compliance distance for the spherical model, $CD_{sph}(\theta, \phi)$ was obtained for each sector shape by solving the following equation for r :

$$\frac{S_{sph}(r, \theta, \phi)}{S_{gp,w}^{lim}} = 1,$$

where $S_{gp,w}^{lim}$ denotes the FCC power density reference levels for general public/uncontrolled and workers/controlled exposure in the frequency range used by the EUT. RF EMF exposure limits are given in Table 4 [1].

Table 4 RF EMF exposure limits applicable for the frequency range used by the EUT [1].

Quantity	General public / Uncontrolled exposure limit	Workers / Controlled exposure limit
Power density S (W/m ²)	10	50

Based on the calculated compliance distances, a box-shaped compliance boundary was determined. To comply with the FCC requirement of a minimum test separation distance for a non-portable device of 20 cm, the minimum distance from the EUT to the compliance boundary was set to 20 cm.

5 Results

A box-shaped compliance boundary is used, characterized by its width, height, and the compliance distances behind and in front of the equipment, see Figure 1. Outside of this box, the RF exposure is below the exposure limits.

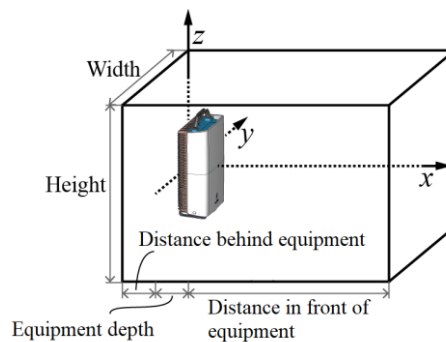

Figure 1 Box-shaped structure specifying the compliance boundary for the tested RBS product.

In Figure 2 to Figure 5 compliance distance results as obtained using the far-field spherical formula for general public (blue line) and workers (red line) exposure are given for the tested configuration leading to the largest compliance boundary for each sector shape. Results are provided for the FCC exposure limits. Also shown are the resulting symmetric compliance boundaries (black lines, solid for general public, dashed for workers exposure). The reported compliance boundary dimensions are given in Table 5 rounded upwards to the nearest decimeter.

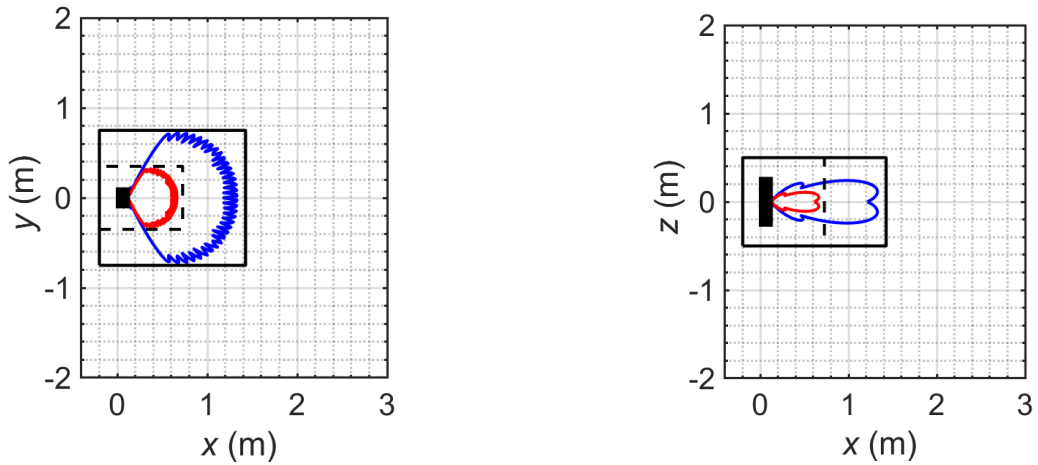

Figure 2 Compliance boundaries for general public (black solid line) and workers (black dashed line) exposure for markets where the FCC exposure limits apply for Hotspot1 sector shape (Config Mode 1). The blue solid lines correspond to compliance distance results for general public exposure obtained using the spherical models. The solid red lines indicate the corresponding compliance distance results for workers exposure. The EUT is shown from above (left) and from the side (right) with its backplane located at $x = 0$ m. Mode: B261 (28 GHz) (NR). Total power delivered to the antenna: 0.51 W.

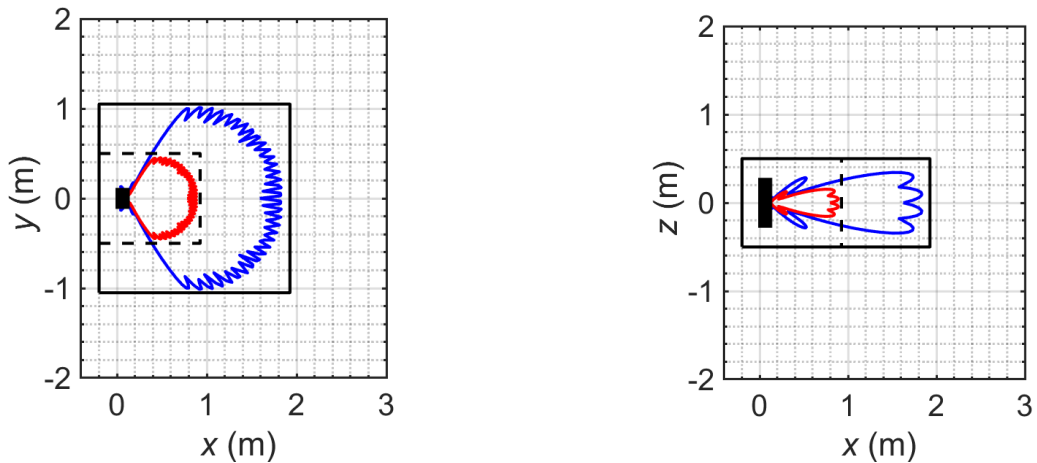

Figure 3 Compliance boundaries for general public (black solid line) and workers (black dashed line) exposure for markets where the FCC exposure limits apply for Hotspot2 sector shape (Config Mode 2). The blue solid lines correspond to compliance distance results for general public exposure obtained using the spherical models. The solid red lines indicate the corresponding compliance distance results for workers exposure. The EUT is shown from above (left) and from the side (right) with its backplane located at $x = 0$ m. Mode: B261 (28 GHz) (NR). Total power delivered to the antenna: 0.51 W.

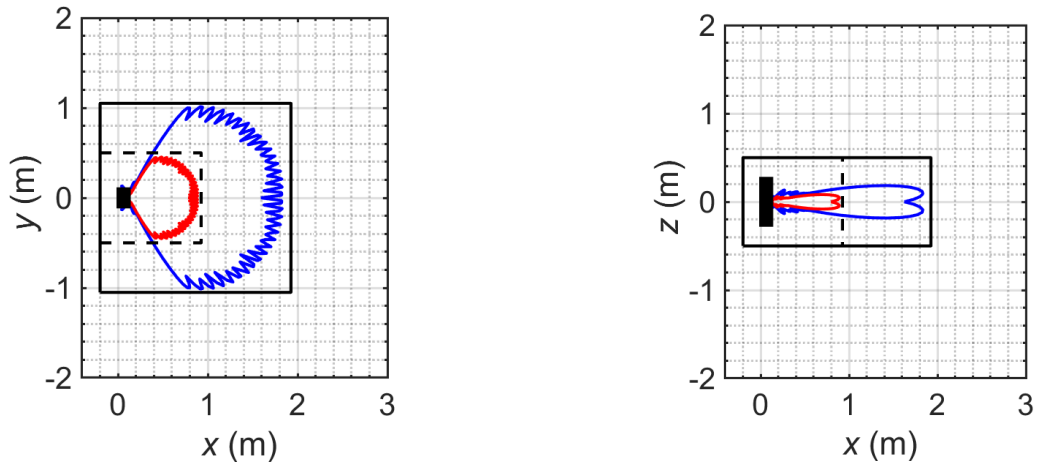

Figure 4 Compliance boundaries for general public (black solid line) and workers (black dashed line) exposure for markets where the FCC exposure limits apply for Macro3 sector shape (Config Mode 2). The blue solid lines correspond to compliance distance results for general public exposure obtained using the spherical models. The solid red lines indicate the corresponding compliance distance results for workers exposure. The EUT is shown from above (left) and from the side (right) with its backplane located at $x = 0$ m. Mode: B261 (28 GHz) (NR). Total power delivered to the antenna: 0.51 W.

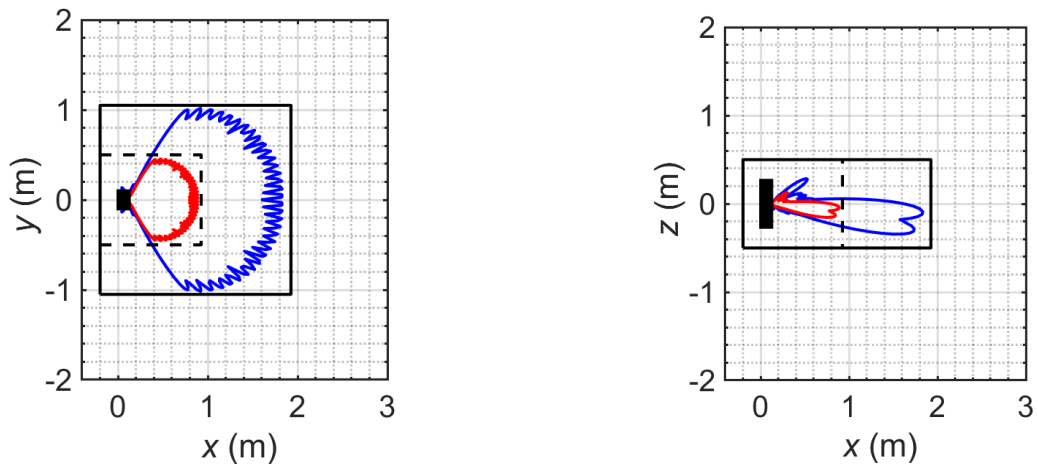

Figure 5 Compliance boundaries for general public (black solid line) and workers (black dashed line) exposure for markets where the FCC exposure limits apply for Macro3b sector shape (Config Mode 2). The blue solid lines correspond to compliance distance results for general public exposure obtained using the spherical models. The solid red lines indicate the corresponding compliance distance results for workers exposure. The EUT is shown from above (left) and from the side (right) with its backplane located at $x = 0$ m. Mode: B261 (28 GHz) (NR). Total power delivered to the antenna: 0.51 W.

Table 5 Dimensions of the box-shaped compliance boundary for general public (GP) and workers (W) exposure for Street Macro 6701 applicable in markets employing the FCC RF exposure limits for maximum output power with power tolerance and TDD downlink duty cycle included.

Mode and output power for Street Macro 6701							Dimensions of the box-shaped compliance boundary (m)							
							Distance in front of EUT		Width		Height		Distance behind EUT	
Band	Standard	Config Mode ⁴	Nominal total EIRP	Power tolerance	TDD DL duty cycle	Sector shapes	GP	W	GP	W	GP	W	GP	W
B261	NR	1	47 dBm	1.5 dB	72.1 %	Hotspot1	0.7	0.3	0.8	0.7	1.0	1.0	0.2	0.2
B261	NR	1, 2	50 dBm	1.5 dB	72.1 %	Hotspot1, Hotspot2, Macro3, Macro3b ⁵	0.9	0.4	1.1	0.7	1.0	1.0	0.2	0.2
B261	NR	1, 2	53 dBm	1.5 dB	72.1 %	Hotspot1, Hotspot2, Macro3, Macro3b	1.3	0.6	1.5	0.7	1.0	1.0	0.2	0.2
B261	NR	2	56 dBm	1.5 dB	72.1 %	Hotspot2, Macro3, Macro3b	1.8	0.8	2.1	1.0	1.0	1.0	0.2	0.2

For the power levels specified in the table which include tolerances, and the upward rounding of compliance boundary dimensions to the nearest decimeter, the specified results are conservative.

6 Uncertainty

For the input parameters defined in the test report, the calculated compliance boundary dimensions determined according the approach described in Section 4 results in an exposure assessment which is conservative. The compliance boundary dimensions were determined by comparing the evaluated RF exposure directly with the limits.

7 Conclusion

The Ericsson Street Macro 6701 B261 has been tested using methods and procedures specified in FCC OET Bulletin 65 [3] and IEC 62232:2017 [4]. The results in Section 5 show the compliance boundary dimensions for the considered configuration of the product. Outside of these compliance boundaries, the RF exposure is below the limits specified in [1].

8 References

- [1] FCC, Code of Federal Regulations CFR title 47, part 1.1310 “Radiofrequency radiation exposure limits”, Federal Communications Commission (FCC), August 1997.
- [2] GFTE-16:001718 Uen, “Ericsson RF exposure calculation procedure for base stations”.
- [3] FCC, “Evaluating compliance with FCC guidelines for human exposure to radiofrequency electromagnetic fields. OET Bulletin 65. Edition 97-01.” Federal Communications Commission (FCC), Office of Engineering and Technology, August 1997.
- [4] IEC 62232:2017, Determination of RF field strength, power density and SAR in the vicinity of radiocommunication base stations for the purpose of evaluating human exposure, June 2017.
- [5] Ericsson, LME-12:001904 Uen, “Exposure to radio frequency electromagnetic fields”.

9 Revision history

Rev.	Date	Description
A	2019-07-10	First revision
B	2019-09-19	Added results for Configuration Mode 1 and 2 at different power levels.

Appendix A. Information to be included in the CPI

Table A.1 lists the compliance boundaries (exclusion zones), outside of which the RF EMF exposure from Street Macro 6701 is below the limits applicable in:

- USA (47 CFR 1.1310)

Information is provided for the theoretical maximum exposure condition.

Table A.1: Dimensions of the box-shaped compliance boundary for general public (GP) and occupational (O) exposure applicable in USA and markets employing the FCC RF exposure limits.

Mode and output power for Street Macro 6701							Dimensions of the box-shaped compliance boundary (m)							
							Distance in front of equipment		Width		Height		Distance behind equipment	
Band	Standard	Configuration Mode	Nominal total EIRP	IEC 62232 installation class	Power tolerance	TDD DL duty cycle	GP	W	GP	W	GP	W	GP	W
B261	NR	1	47 dBm	E100	1.5 dB	72.1 %	0.7	0.3	0.8	0.7	1.0	1.0	0.2	0.2
B261	NR	1, 2	50 dBm	E100	1.5 dB	72.1 %	0.9	0.4	1.1	0.7	1.0	1.0	0.2	0.2
B261	NR	1, 2	53 dBm	E+	1.5 dB	72.1 %	1.3	0.6	1.5	0.7	1.0	1.0	0.2	0.2
B261	NR	2	56 dBm	E+	1.5 dB	72.1 %	1.8	0.8	2.1	1.0	1.0	1.0	0.2	0.2

(1) The compliance boundaries are determined for maximum output power with power tolerance and TDD downlink duty cycle included.

Appendix B. Guidelines on how to install the product

The Ericsson Street Macro 6701 product (KRK 101 01/1, KRK 101 01/2, KRK 101 01/11, KRK 101 01/21) shall be installed to make sure that the general public does not have access to the applicable RF EMF compliance boundary. The compliance boundary dimensions were determined for the product transmitting in free space.

Appendix C. Guidelines for workers during installation, maintenance, and repair of the product

For Ericsson Street Macro 6701 product (KRK 101 01/1, KRK 101 01/2, KRK 101 01/11, KRK 101 01/21), if work needs to be performed within the compliance boundary applicable for workers, the radio equipment shall be powered off, or the power be reduced to a level ensuring that the RF EMF exposure is below the relevant exposure limit for workers.

If work is conducted on behalf of Ericsson, minimum EMF related requirements are provided in [5].

Appendix D. Picture of Street Macro 6701

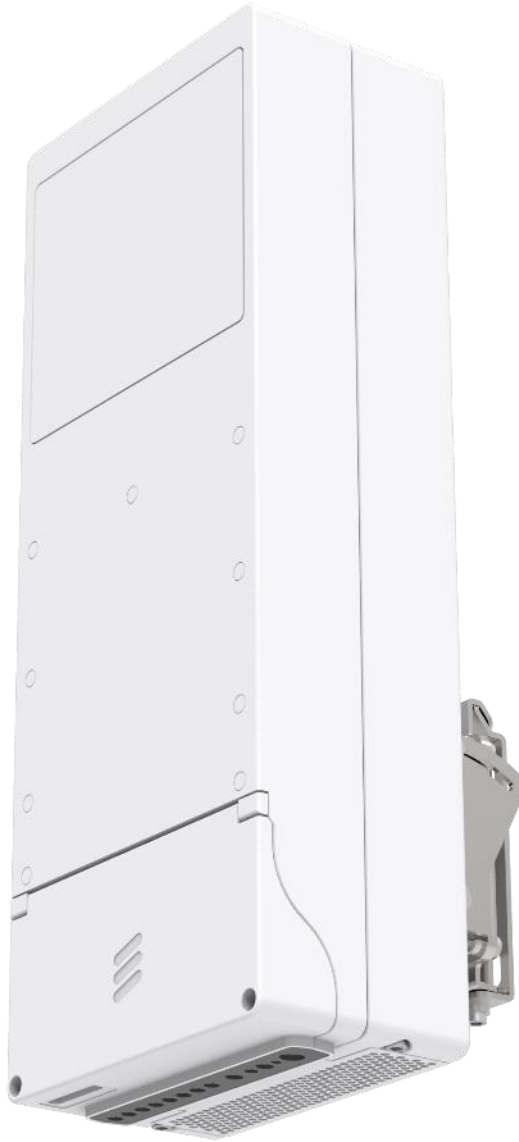

Figure D.1 Picture of Street Macro 6701