



Product Service

Choose certainty.
Add value.



Report On

FCC Testing of the
Ericsson AB (700MHz) RBS 6501 B13 KRD 901 113/X* Radio Base
Station In accordance with FCC CFR 47 Part 27

* See note on page 4

COMMERCIAL-IN-CONFIDENCE

FCC ID: TA8AKRD901113

PREPARED BY

Guangdi Dong
Project Engineer

APPROVED BY

Nic Forsyth
Authorised Signatory

DATED

14 February 2014

Document 75925374 Report 01 Issue 1

February 2014

CONTENTS

Section	Page No
1	REPORT INFORMATION 3
1.1	Report Details 4
1.2	Brief Summary of Results 5
1.3	Configuration Description 6
1.4	Declaration of Build Status 7
1.5	Product Information 8
1.6	Test Setup 9
1.7	Test Conditions 11
1.8	Deviation From The Standard 11
1.9	Modification Record 11
1.10	Alternative Test Site 11
2	TEST DETAILS 12
2.1	Maximum Peak Output Power and Peak to Average Ratio - Conducted 13
2.2	Maximum Peak Output Power - Radiated 15
2.3	Occupied Bandwidth 18
2.4	Spurious Emission at Band Edge 21
2.5	Radiated Spurious Emissions 30
2.6	Conducted Spurious Emissions 35
2.7	Frequency Stability 49
3	TEST EQUIPMENT USED 51
3.1	Test Equipment Used 52
3.2	Measurement Uncertainty 54
4	ACCREDITATION, DISCLAIMERS AND COPYRIGHT 55
4.1	Accreditation, Disclaimers and Copyright 56



Product Service

SECTION 1

REPORT INFORMATION

1.1 INTRODUCTION

Testing was carried out in support of an application for Grant of RBS 6501 B13 KRD 901 113/X* in LTE mode.

Manufacturer	Ericsson AB
Address	Isafjordsgatan 10 SE-164 80 Stockholm 16480 Sweden
Product Name	RBS 6501 B13
Product Number	KRD 901 113/X*
Serial Number(s)	CB4S376829 CB4S430808
Software Version	CXP 102 051/19 Rev R32AT
Hardware Version	R1A
Test Specification/Issue/Date	FCC CFR 47 Part 27: 2013
Start of Test	13 January 2014
Finish of Test	07 February 2014
Name of Engineer(s)	Guangdi Dong
Related Document(s)	ANSI C63.4: 2009 FCC CFR 47 Part 2: 2013

*Note: X can be 1 to 4.

RBS 6501 B13 is available in the following four variants with the listed product numbers and descriptions. The differences between them are as follows:

Product Number	Description
KRD 901 113/1	100 - 250 VAC power feed with integrated antenna
KRD 901 113/2	-48 VDC power feed with integrated antenna
KRD 901 113/3	100 - 250 VAC power feed without integrated antenna
KRD 901 113/4	-48 VDC power feed without integrated antenna

1.2 BRIEF SUMMARY OF RESULTS

A brief summary of results for each configuration, in accordance with FCC CFR 47 Part 2 and Part 27 is shown below.

Section	Spec Clause		Test Description	Result
	Part 2	Part 27		
2.1	2.1046	27.50 (b)	Maximum Peak Output Power and Peak to Average Ratio – Conducted	Pass
2.2	-	27.50 (b)	Maximum Peak Output Power – Radiated	Pass
2.3	2.1049	27.53 (c)	Occupied Bandwidth	Pass
2.4	2.1051	27.53 (c)	Spurious Emissions at Band Edge	Pass
2.5	2.1053	27.53 (c)	Radiated Spurious Emissions	Pass
2.6	2.1051	27.53 (c) , (f)	Conducted Spurious Emissions	Pass
2.7	2.1055	27.54	Frequency Stability	Pass
-	-	-	Receiver Spurious Emissions	N/A

N/A – Not Applicable

1.3 CONFIGURATION DESCRIPTION

Configuration Code	Carrier(s)	Configuration Description
L-MIMO-SC	1C	LTE MIMO, Single Carrier
L-MIMO-MC 1	2C	LTE MIMO, Multi Carrier x2

1.4 DECLARATION OF BUILD STATUS

MAIN EUT	
MANUFACTURING DESCRIPTION	Radio Base Station
MANUFACTURER	Ericsson AB
PRODUCT NAME	RBS 6501 B13
PRODUCT NUMBER	KRD 901 113/1 KRD 901 113/2 KRD 901 113/3 KRD 901 113/4
TRANSMITTER OPERATING RANGE	TX: 746MHz - 756MHz RX: 777MHz - 787MHz
MODULATIONS	QPSK, 16QAM, 64QAM
INTERMEDIATE FREQUENCIES	-
ITU DESIGNATION OF EMISSION	5M00F9W, 10M0F9W
SUPPORTED CHANNEL BANDWIDTH CONFIGURATION	5MHz, 10MHz
OUTPUT POWER (RMS) (W or dBm)	MIMO: 2 x 37dBm (2 x 5W)
Antenna Gain	Internal antenna KRE 101 2135/1: >5dBi Semi-integrated Omni antenna KRE 101 2245/1: 2dBi
INSTANTANEOUS BANDWIDTH	10MHz
FCC ID	TA8AKRD901113
AC Power source	100-250 V AC
DC Power source	-48V DC
TECHNICAL DESCRIPTION (a brief description of the intended use and operation)	The equipment is a LTE Radio Base Station

Signature

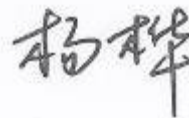

Date

07 February 2014

D of B S Serial No

75925374/01

No responsibility will be accepted by TÜV SÜD Product Service as to the accuracy of the information declared in this document by the manufacturer.

1.5 PRODUCT INFORMATION

1.5.1 Technical Description

The Equipment Under Test (EUT) RBS 6501 B13 KR D 901 113/X is an Ericsson Radio Base Station working in the public mobile service 700 MHz band which provides communication connections to 700MHz network in LTE Modes. The RBS 6501 B13 Radio Base Station supports 100 - 250 VAC and -48 VDC power supply.

The RBS 6501 B13 KR D 901 113/X Radio Base Station is likely to use an integrated wide sector antenna or semi-integrated omni antenna.

The Equipment Under Test (EUT) is shown in the photograph below. A full technical description can be found in the manufacturer's documentation.



Equipment Under Test

1.6 TEST SETUP

Test Setup, Conducted Measurement:

Configuration setup:

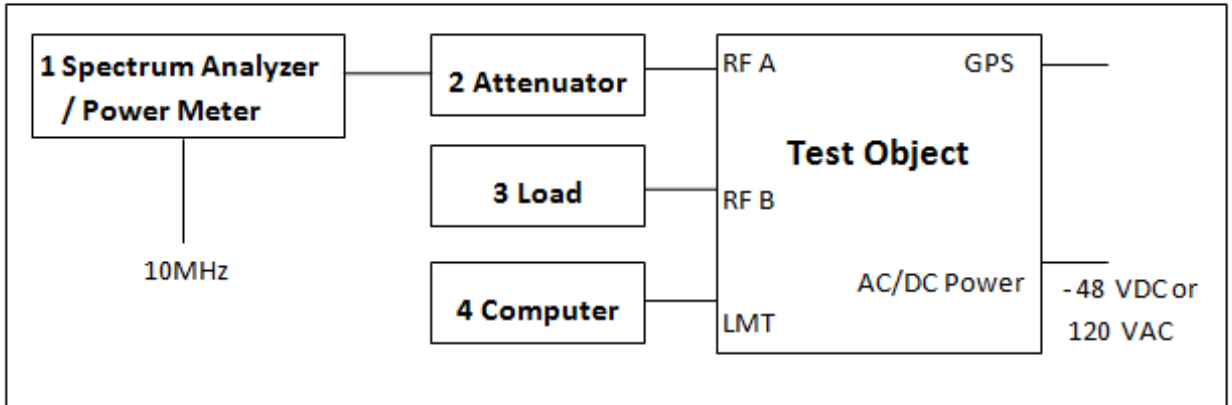

Product Name	Product Number	Version	Serial Number
RBS 6501 B13	KRD 901 113/1	R1A	CB4S430808
RBS 6501 B13	KRD 901 113/4	R1A	CB4S376829

No.	Auxiliary Equipment	Part Number / Model Type	Version	Serial Number
1	Spectrum Analyzer	FSQ26	--	200687
	Power Meter	NRP	--	101593
	Power Sensor	NRP-Z51	--	102123
2	Attenuator	48-40-43-LIM	--	BR5020
3	Load	TFE100	--	09121647
4	Computer	Advantech-610H	--	ETD/L913

Test Setup, Radiated Measurement:

Base Station setup:

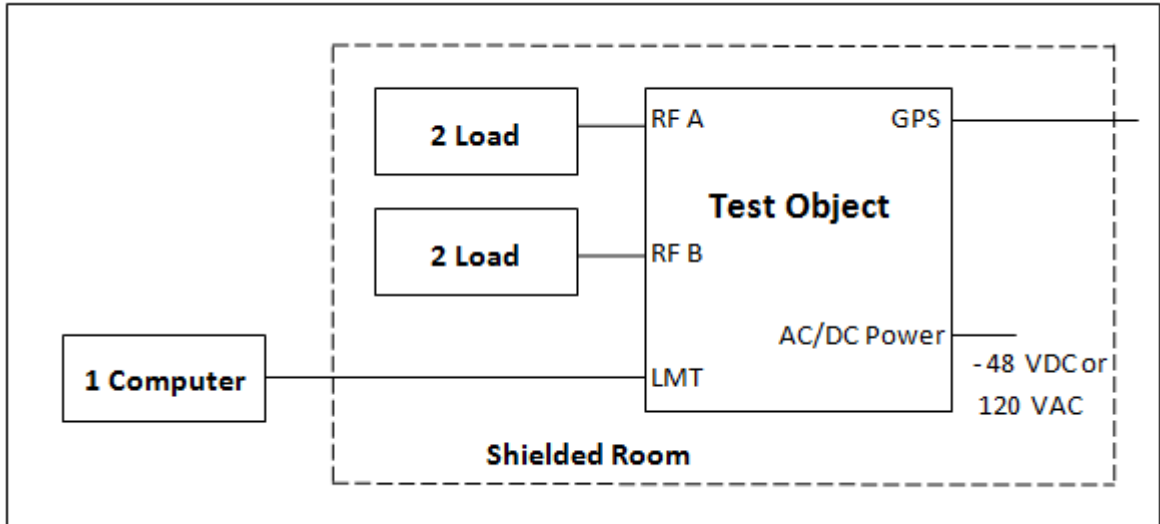

Product Name	Product Number	Version	Serial Number
RBS 6501 B13	KRD 901 113/1	R1A	CB4S430808
RBS 6501 B13	KRD 901 113/4	R1A	CB4 S376829

No.	Auxiliary Equipment	Part Number / Model Type	Version	Serial Number
1	Computer	Advantech-610H	--	ETD/L913
2	Load	TFE100	--	09121647
	Load	TFZ10-3R	--	20100908079

1.7 TEST CONDITIONS

For all tests the EUT was set up in accordance with the relevant test standard and to represent typical operating conditions. Tests were applied with the EUT situated in a shielded enclosure, test laboratories or a chamber as appropriate.

All test cases were tested with the EUT supplied with -48V DC by an external power supply. Frequency stability measurements were tested using both -48V DC and 120V AC.

1.8 DEVIATION FROM THE STANDARD

No deviations from the applicable test standards or test plan were made during testing.

1.9 MODIFICATION RECORD

Modification State 0 - No modifications were made to the EUT during testing.

1.10 ALTERNATIVE TEST SITE

Under our group UKAS Accreditation, TÜV SÜD Product Service conducted the following tests at Ericsson in Beijing, China:

- Maximum Average Output Power and Peak to Average Ratio – Conducted
- Occupied Bandwidth
- Band Edge
- Conducted Spurious Emissions
- Frequency Stability

Radiated Spurious Emissions and Maximum Average Output Power Radiated testing have been performed under the following site registrations:

FCC Accreditation 910917:

The State Radio Monitoring Centre, No.80 Beilishi Road, Xicheng District, Beijing, China.



Product Service

SECTION 2

TEST DETAILS

2.1 MAXIMUM PEAK OUTPUT POWER AND PEAK TO AVERAGE RATIO - CONDUCTED

2.1.1 Specification Reference

FCC CFR 47 Part 2, Clause 2.1046
FCC CFR 47 Part 27, Clause 27.50 (b)

2.1.2 Equipment Under Test

RBS 6501 B13, KRD 901 113/4, S/N: CB4S376829

2.1.3 Date of Test and Modification State

13 January 2014 - Modification State 0

2.1.4 Test Equipment Used

The major items of test equipment used for the above tests are identified in Section 3.1.

2.1.5 Environmental Conditions

Ambient Temperature	23.5 °C
Relative Humidity	21.5 %

2.1.6 Test Method

The path loss between the EUT and the power sensor was measured and recorded for the test band. The path loss was entered as an offset into the Power Meter and Spectrum Analyzer. The EUT was configured to transmit on Maximum Power on the configurations defined in the tables below. Using a power meter and attenuator(s), the output power of the EUT was measured at the antenna terminal. A peak to average ratio measurement was performed at the conducted port of the EUT. The spectrum analyser Complementary Cumulative Distribution Function (CCDF) was used to determine the largest deviation between the average and the peak power of the EUT in given bandwidth. A resolution bandwidth of 10MHz was used. The Average Power and Peak to Average Ratio was measured and recorded with the results being compared with the limits. In the case of MIMO devices, the power was measured from each antenna port and the results summed in accordance with FCC KDB 662911 D01 Multiple Transmitter Output v02r01.

2.1.7 Test Results

Configuration L-MIMO-SC

Maximum Output Power 37.0dBm per carrier

Antenna	Modulation / Carrier Bandwidth (MHz)	Average Output Power / Peak to Average Ratio (PAR)								
		Channel Position B 748.5MHz			Channel Position M 751.0MHz			Channel Position T 753.5MHz		
		Power (dBm)	Power (dBm/MHz ¹)	PAR (dB)	Power (dBm)	Power (dBm/MHz ¹)	PAR (dB)	Power (dBm)	Power (dBm/MHz ¹)	PAR (dB)
A	QPSK / 5.0 MHz	36.86	30.02	6.75	36.88	30.04	6.83	36.83	29.99	6.95
B		36.75	29.91	6.78	36.82	29.98	6.81	36.78	29.94	6.93
Total		39.81	-	-	39.86	-	-	39.81	-	-

Note 1:

1 MHz Power for 5MHz BW=Output Power - 10lg(OBW/1)=Output Power - 10lg(4.83) =Output Power – 6.84

Antenna	Modulation / Carrier Bandwidth (MHz)	Average Output Power / Peak to Average Ratio (PAR)								
		Channel Position B 748.5MHz			Channel Position M 751.0MHz			Channel Position T 753.5MHz		
		Power (dBm)	Power (dBm/MHz ¹)	PAR (dB)	Power (dBm)	Power (dBm/MHz ¹)	PAR (dB)	Power (dBm)	Power (dBm/MHz ¹)	PAR (dB)
A	QPSK / 10.0 MHz	-	-	-	36.78	27.04	7.07	-	-	-
B		-	-	-	36.74	27.00	7.14	-	-	-
Total		-	-	-	39.77	-	-	-	-	-

Note 1:

1 MHz Power for 10MHz BW=Output Power - 10lg(OBW/1)=Output Power - 10lg(9.42) =Output Power – 9.74

Configuration L-MIMO-MC 1 (2C)

Maximum Output Power 34.0dBm per carrier

Antenna	Carrier Bandwidth (MHz)	Average Output Power / Peak to Average Ratio (PAR)					
		Channel Position B -		Channel Position M _{RFBW} 748.5MHz + 753.5MHz		Channel Position T -	
		Power (dBm)	PAR (dB)	Power (dBm)	PAR (dB)	Power (dBm)	PAR (dB)
A	QPSK / 5.0 MHz	-	-	36.84	6.99	-	-
B		-	-	36.77	6.93	-	-
Total		-	-	39.81	-	-	-

Limit	
Peak Power	≤ 1000 W (ERP)/ MHz or ≤+60 dBm/MHz
Peak to Average Ratio	13 dB

2.2 MAXIMUM PEAK OUTPUT POWER - RADIATED

2.2.1 Specification Reference

FCC CFR 47 Part 27, Clause 27.50 (b)

2.2.2 Equipment Under Test

RBS 6501 B13 , KR D 901 113/4, S/N: CB4S376829

2.2.3 Date of Test and Modification State

15 and 28 January 2014 - Modification State 0

2.2.4 Test Equipment Used

The major items of test equipment used for the above tests are identified in Section 3.1.

2.2.5 Environmental Conditions

Ambient Temperature	25.5 – 27.5°C
Relative Humidity	26.3 – 27.0%

2.2.6 Test Method

The measurements were performed according to ANSI C63.4.

The EUT was set to transmit at maximum power and testing was carried out on bottom, middle and top Channels. The test of radiated emission was performed in a semi anechoic chamber. The measurements were performed with both horizontal and vertical polarizations of the antennas. The antenna distance was 3.0 m.

The fundamental was scanned with peak detector with the antenna height varied between 1-4 m and the turntable rotated between 0-360 degrees for maximum response. The carrier power was measured with RMS detector activated with a RBW of 1MHz. The output power was verified with the substitution method. The antenna distance during the measurements was 3.0m.

2.2.7 Test Results

Configuration L-MIMO-SC

Maximum Output Power 37.0dBm per carrier

Internal antenna KRE 101 2135/1, upright mounted

Bandwidth Configuration (MHz)	Channel Position B	Vertical/Horizontal RMS power	
		dBm/MHz	W/MHz
5.0	748.5MHz	39.5/41.9	8.91/15.49

Bandwidth Configuration (MHz)	Channel Position M	Vertical/Horizontal RMS power	
		dBm/MHz	W/MHz
5.0	751.0MHz	39.8/41.8	9.55/15.14
10.0		36.3/38.2	4.27/6.61

Bandwidth Configuration (MHz)	Channel Position T	Vertical/Horizontal RMS power	
		dBm/MHz	W/MHz
5.0	753.5MHz	39.2/40.3	8.32/10.72

Internal antenna KRE 101 2135/1, side mounted

Bandwidth Configuration (MHz)	Channel Position B	Vertical/Horizontal RMS power	
		dBm/MHz	W/MHz
5.0	748.5MHz	40.9/41.4	12.30/13.80

Bandwidth Configuration (MHz)	Channel Position M	Vertical/Horizontal RMS power	
		dBm/MHz	W/MHz
5.0	751.0MHz	41.0/40.3	12.59/10.72
10.0		32.3/36.7	1.70/4.68

Bandwidth Configuration (MHz)	Channel Position T	Vertical/Horizontal RMS power	
		dBm/MHz	W/MHz
5.0	753.5MHz	40.9/40.2	12.30/10.47

Semi-integrated Omni antenna KRE 101 2245/1, upright mounted

Bandwidth Configuration (MHz)	Channel Position B	Vertical/Horizontal RMS power	
		dBm/MHz	W/MHz
5.0	748.5MHz	38.4/30.6	6.92/1.15

Bandwidth Configuration (MHz)	Channel Position M	Vertical/Horizontal RMS power	
		dBm/MHz	W/MHz
5.0	751.0MHz	38.6/30.7	7.42/1.17
10.0	751.0MHz	35.3/27.6	3.39/0.58

Bandwidth Configuration (MHz)	Channel Position T	Vertical/Horizontal RMS power	
		dBm/MHz	W/MHz
5.0	753.5MHz	38.7/30.7	7.41/1.17

Semi-integrated Omni antenna KRE 101 2245/1, side mounted

Bandwidth Configuration (MHz)	Channel Position B	Vertical/Horizontal RMS power	
		dBm/MHz	W/MHz
5.0	748.5MHz	36.1/31.3	4.07/1.35

Bandwidth Configuration (MHz)	Channel Position M	Vertical/Horizontal RMS power	
		dBm/MHz	W/MHz
5.0	751.0MHz	36.3/31.4	4.27/1.38
10.0	751.0MHz	33.2/28.7	2.09/0.74

Bandwidth Configuration (MHz)	Channel Position T	Vertical/Horizontal RMS power	
		dBm/MHz	W/MHz
5.0	753.5MHz	36.3/31.1	4.27/1.29

Limit	
ERP	≤ 1000 W / MHz or ≤+60 dBm/MHz

2.3 OCCUPIED BANDWIDTH

2.3.1 Specification Reference

FCC CFR 47 Part 2, Clause 2.1049 (h)
 FCC CFR 47 Part 27, Clause 27.53 (c)

2.3.2 Equipment Under Test

RBS 6501 B13, KRD 901 113/4, S/N: CB4S376829

2.3.3 Date of Test and Modification State

13 and 23 January 2014 - Modification State 0

2.3.4 Test Equipment Used

The major items of test equipment used for the above tests are identified in Section 3.1.

2.3.5 Environmental Conditions

Ambient Temperature 21.5 – 22.8°C
 Relative Humidity 22.5 – 24.5%

2.3.6 Test Method

The EUT was set to transmit at maximum power and testing was carried out on Bottom, Middle and Top Channels. Using the Occupied Bandwidth measurement function in the Spectrum Analyser, the Occupied Bandwidth is defined as the width of the signal between two points, one below the carrier centre frequency and one above the carrier centre frequency, outside of which all emissions are attenuated by at least X dB below the transmitter power, where the value of X is typically specified as 26. The Occupied Bandwidth was measured from each antenna port in accordance with FCC KDB 971168 D01 v02r01.

The results are shown in the plots below.

2.3.7 Test Results

Configuration L-MIMO-SC

Maximum Output Power 37.0dBm per carrier

Modulation / Bandwidth	Occupied Bandwidth (MHz)		
	Channel Position B 748.5MHz	Channel Position M 751.0MHz	Channel Position T 753.5MHz
QPSK / 5.0 MHz	4.83	4.83	4.83

Modulation / Bandwidth	Occupied Bandwidth (MHz)		
	Channel Position B -	Channel Position M 751.0MHz	Channel Position T -
QPSK / 10.0 MHz	-	9.42	-

Channel Position B - QPSK / Bandwidth 5.0 MHz

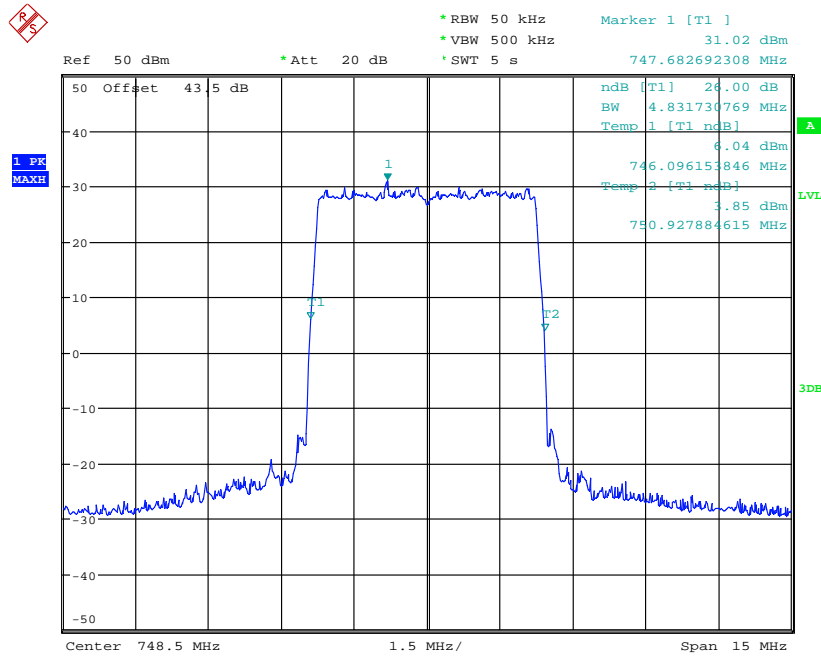

Date: 23.JAN.2014 11:23:35

Channel Position M - QPSK / Bandwidth 5.0 MHz

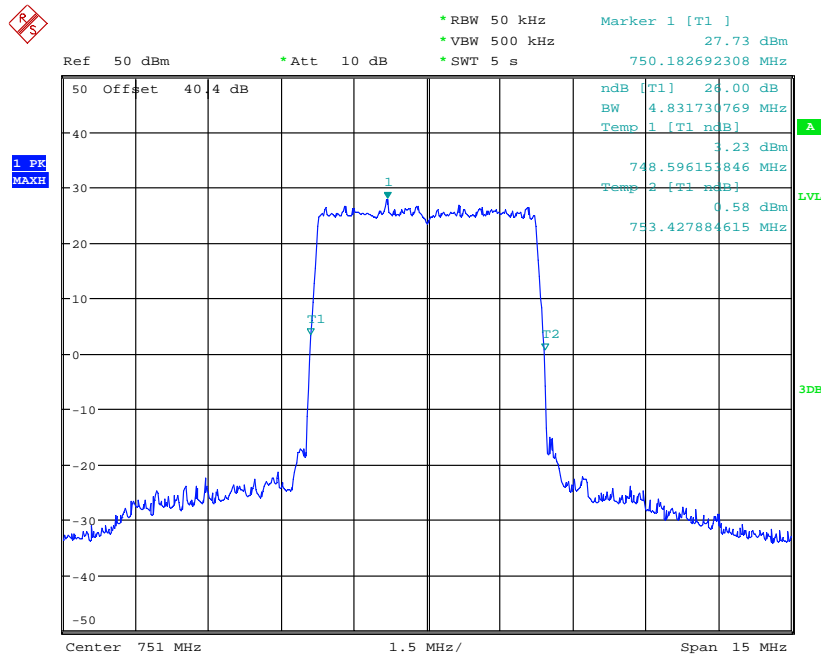

Date: 23.JAN.2014 13:56:26

Channel Position M - QPSK / Bandwidth 10.0 MHz

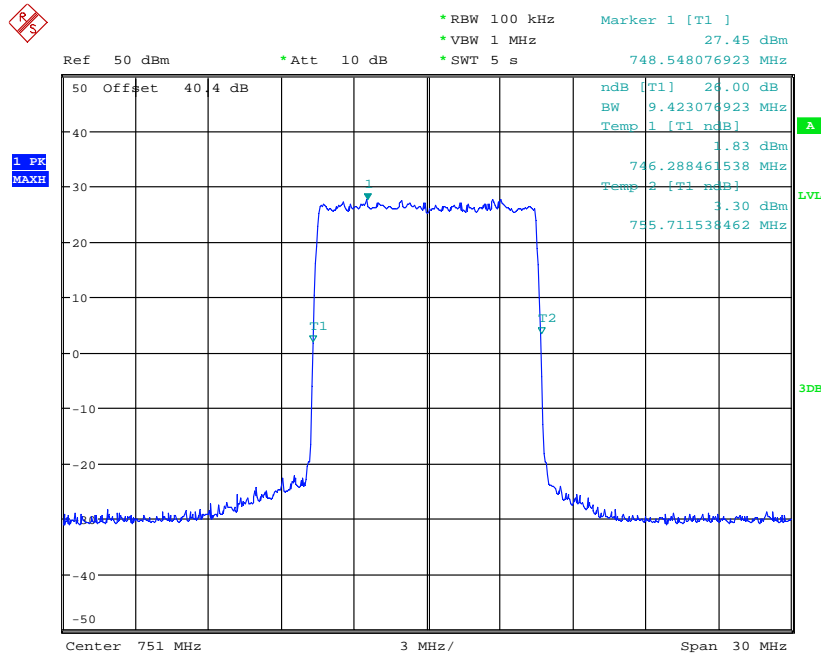

Date: 23.JAN.2014 13:59:46

Channel Position T - QPSK / Bandwidth 5.0 MHz

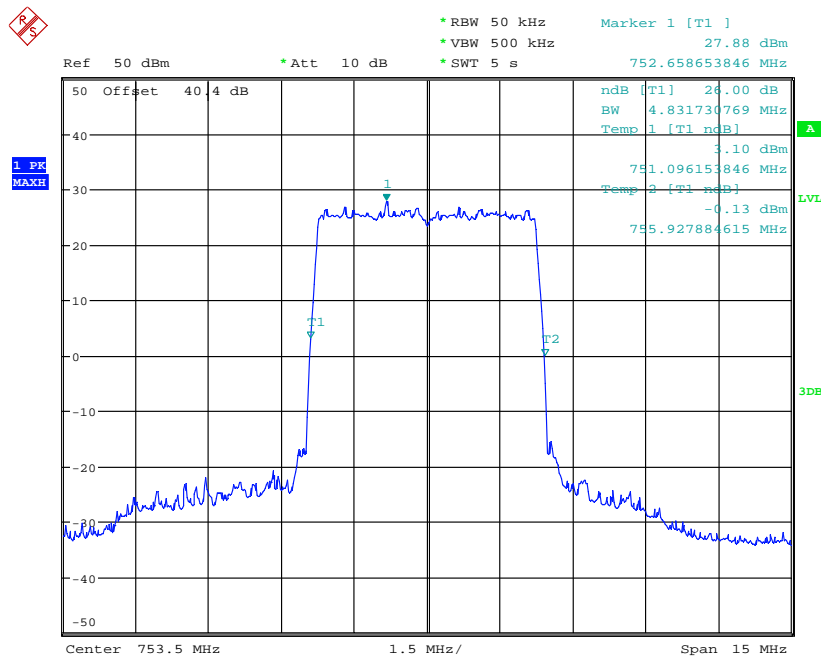

Date: 23.JAN.2014 13:49:48

2.4 SPURIOUS EMISSION AT BAND EDGE

2.4.1 Specification Reference

FCC CFR 47 Part 2, Clause 2.1051
FCC CFR 47 Part 27, Clause 27.53 (c)

2.4.2 Equipment Under Test

RBS 6501 B13, KRD 901 113/4, S/N: CB4S376829

2.4.3 Date of Test and Modification State

23 January 2014 - Modification State 0

2.4.4 Test Equipment Used

The major items of test equipment used for the above tests are identified in Section 3.1.

2.4.5 Environmental Conditions

Ambient Temperature	23.5 °C
Relative Humidity	22.5 %

2.4.6 Test Method

In accordance with FCC CFR 47 Part 27, Clause 27.53 (c), any emissions outside of the block edges shall be attenuated by at least $43 + 10 \log(P)$. In the 1MHz bands immediately outside and adjacent to the frequency block, a resolution bandwidth of at least 1% of the emission bandwidth should be used.

For measurements of emissions > 1MHz away from the band edges, an RBW of 100 kHz or greater should be used.

For MIMO mode configurations, the limit was adjusted with a correction of $-3\text{dB} [10\log(2)]$ by using the Measure and Add $10\log(N)$ dB technique according to FCC KDB662911 D01 accounting for simultaneous transmission from antennas port RF A and RF B.

The path loss was measured and entered as a reference level offset. The EUT was set to transmit at its maximum rated output power in the configurations described in the tables below. Measurements were made at the top and bottom of the band for 5 MHz channel bandwidth and the middle of the band for 10MHz channel bandwidth.

The results are shown in the plots below.

2.4.7 Test Results

Configuration L-MIMO-SC

Maximum Output Power 37.0dBm per carrier

Band Edge Frequency	Channel Bandwidth	Edge Test with modulation QPSK Channel Frequencies
Channel Position B 746.0 MHz	5.0 MHz	748.5 MHz
	10.0 MHz	751.0 MHz
Channel Position T 756.0 MHz	5.0 MHz	753.5 MHz
	10.0 MHz	751.0 MHz

Note: The channels shown in the table above are the minimum and maximum channels that can be used in the authorised frequency ranges to maintain compliance. Channels outside of the ranges shown in the above tables shall not be made available to the end user.

Channel Position B - QPSK / Bandwidth 5.0 MHz

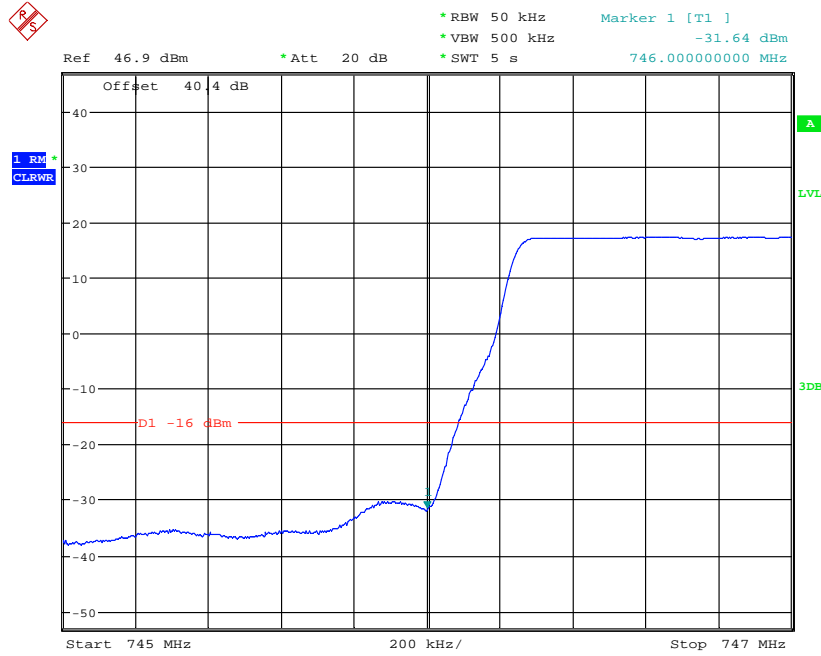

Date: 23.JAN.2014 11:26:19

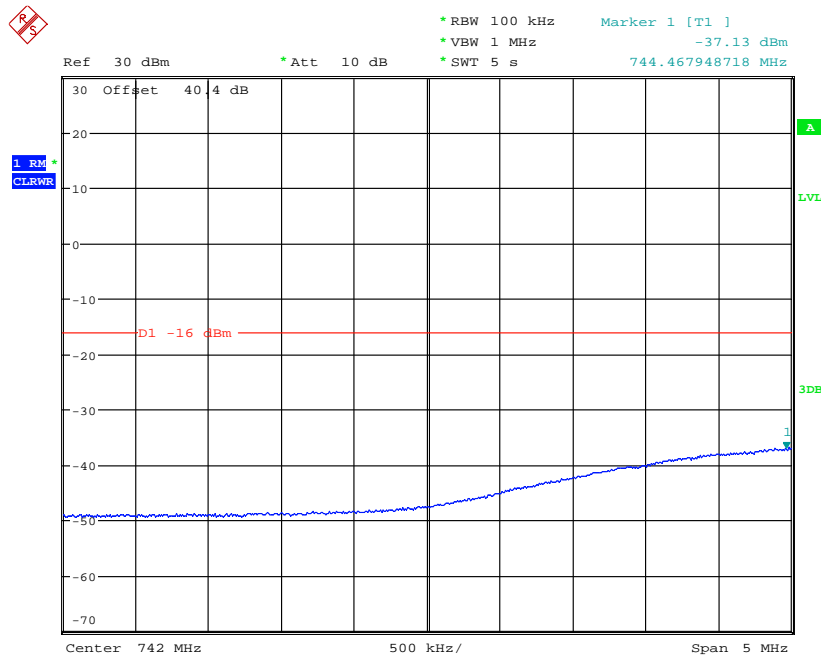

Date: 23.JAN.2014 11:29:04

Channel Position B - QPSK / Bandwidth 10.0 MHz

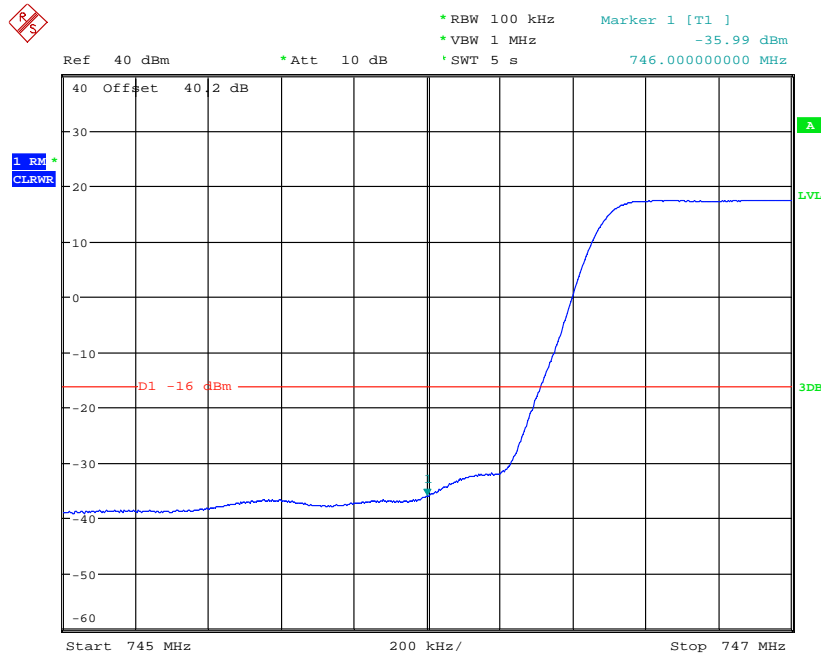

Date: 13.JAN.2014 14:07:56

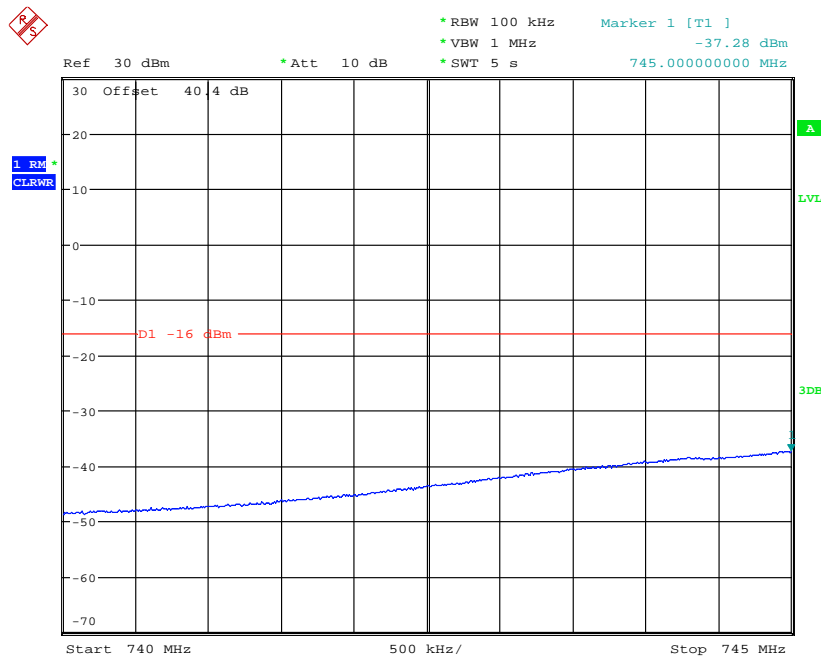

Date: 23.JAN.2014 14:05:47

Channel Position T - QPSK / Bandwidth 5.0 MHz

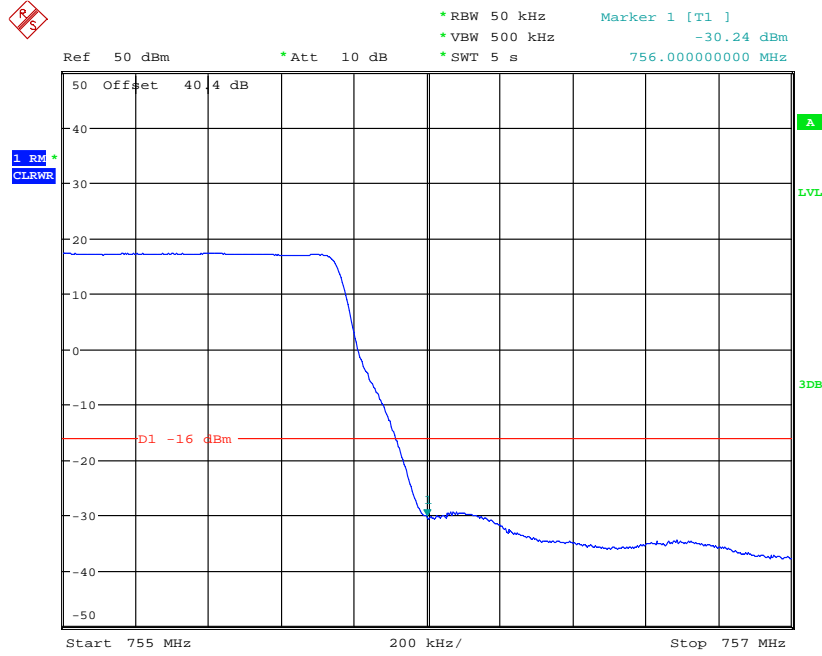

Date: 23.JAN.2014 13:51:19

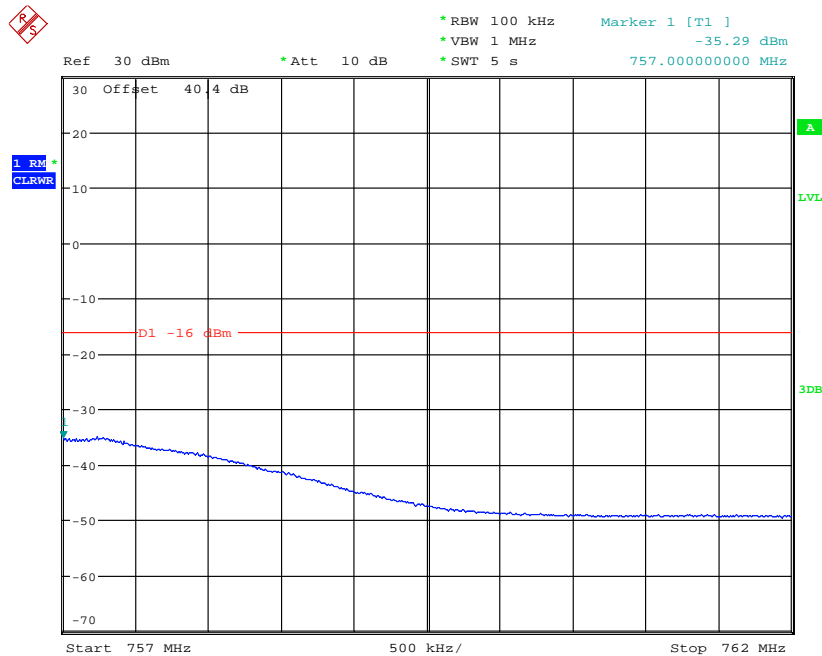

Date: 23.JAN.2014 13:52:34

Channel Position T - QPSK / Bandwidth 10.0 MHz

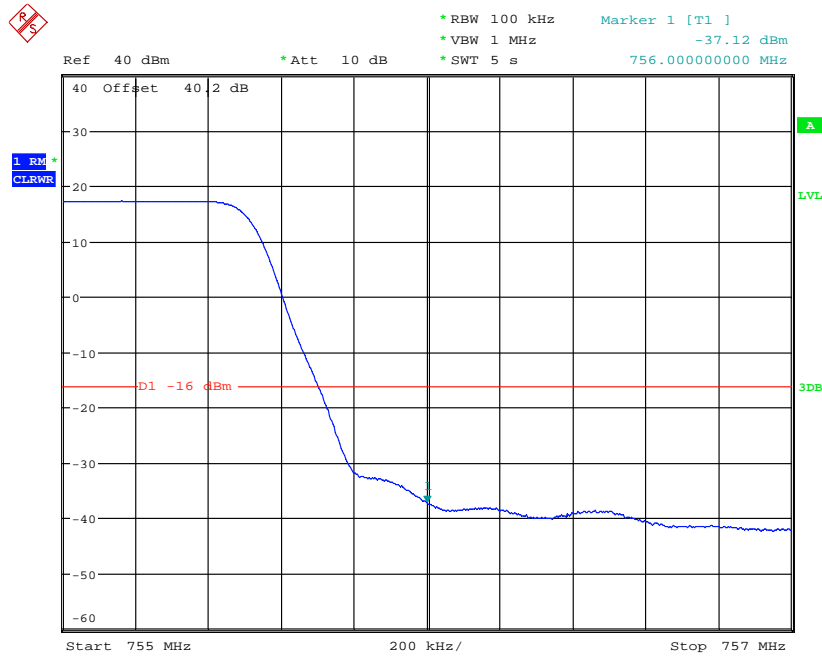

Date: 13.JAN.2014 14:08:38

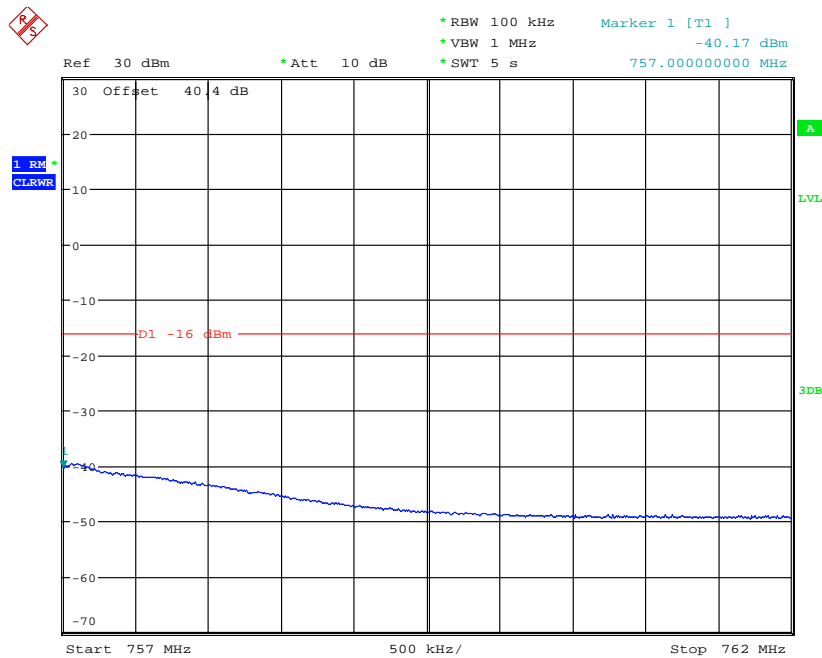

Date: 23.JAN.2014 14:07:31

Configuration L-MIMO-MC 1 (2C)

Maximum Output Power 34.0dBm per carrier

Band Edge Frequency	Channel Bandwidth	Edge Test with modulation QPSK Channel Frequencies
Channel Position B_{RFBW} 746.0 MHz	5.0 MHz	748.5 MHz + 753.5 MHz
	10.0 MHz	-
Channel Position T_{RFBW} 756.0 MHz	5.0 MHz	748.5 MHz + 753.5 MHz
	10.0 MHz	-

Note: The channels shown in the table above are the minimum and maximum channels that can be used in the authorised frequency ranges to maintain compliance. Channels outside of the ranges shown in the above tables shall not be made available to the end user.

Channel Position B_{RFBW} - QPSK / Bandwidth 5.0 MHz

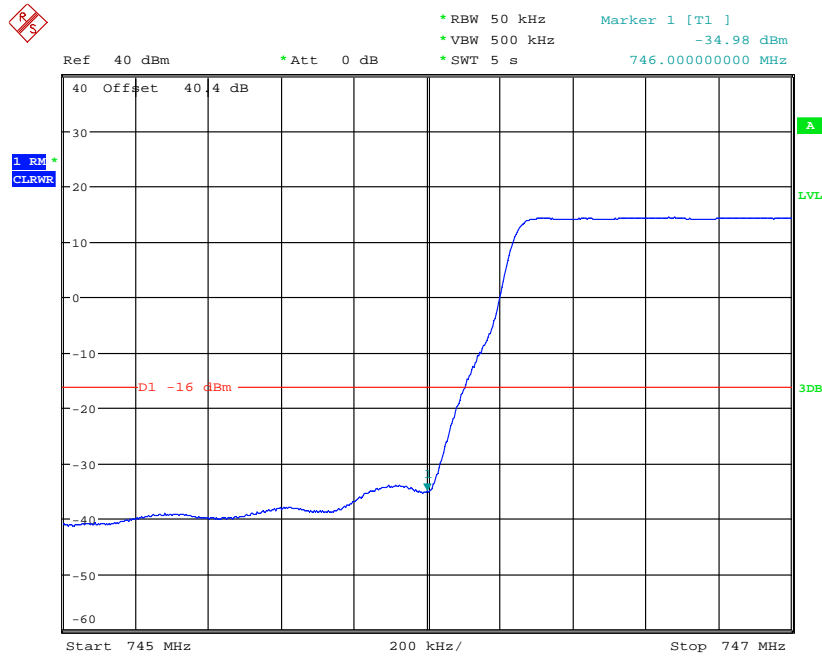

Date: 23.JAN.2014 14:24:40

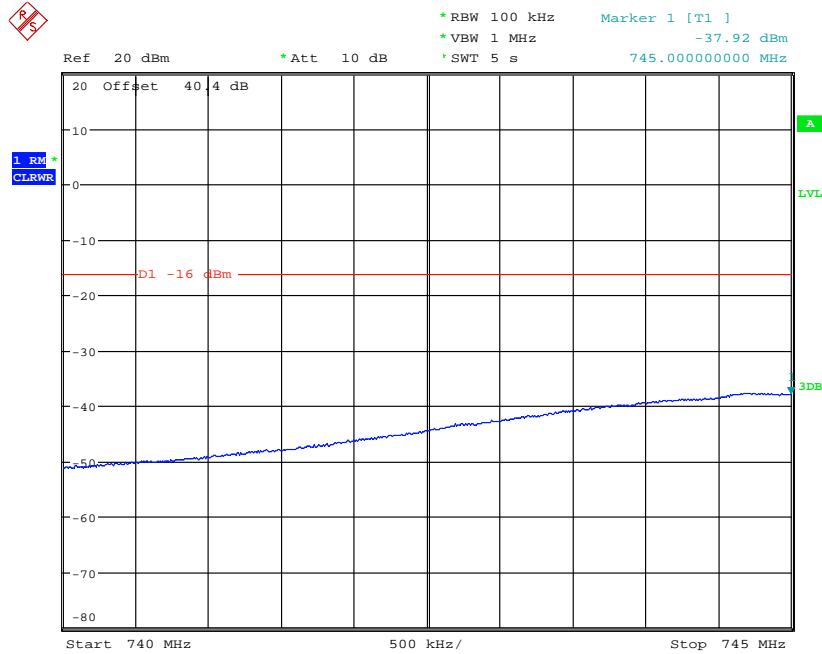

Date: 23.JAN.2014 14:26:14

Channel Position T_{RFBW} – QPSK / Bandwidth 5.0 MHz

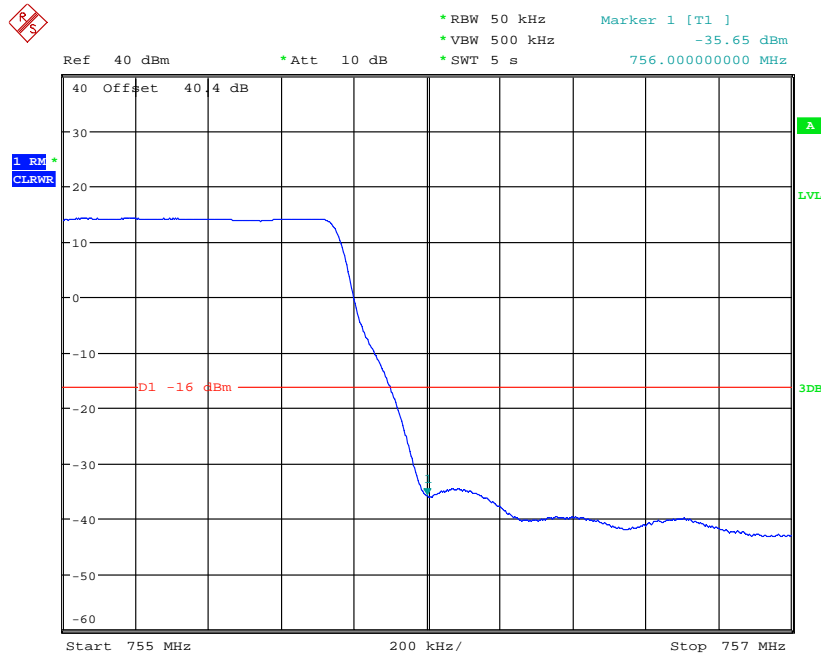

Date: 23.JAN.2014 14:28:30

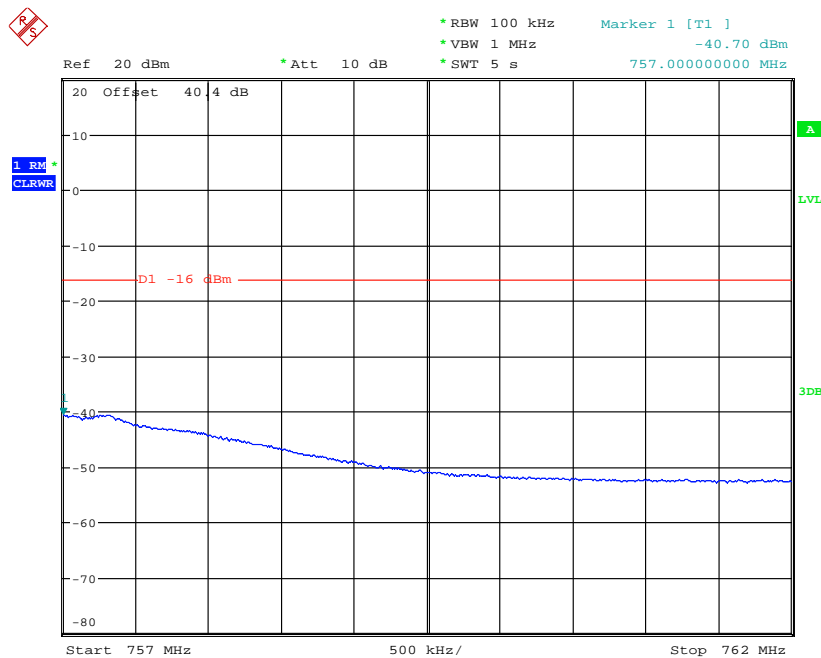

Date: 23.JAN.2014 14:27:08

Limit	-13 dBm
-------	---------

2.5 RADIATED SPURIOUS EMISSIONS

2.5.1 Specification Reference

FCC CFR 47 Part 2, Clause 2.1053
FCC CFR 47 Part 27, Clause 27.53 (c)

2.5.2 Equipment Under Test

RBS 6501 B13, KRD 901 113/4, S/N: CB4S376829

2.5.3 Date of Test and Modification State

14 January 2014 - Modification State 0

2.5.4 Test Equipment Used

The major items of test equipment used for the above tests are identified in Section 3.1.

2.5.5 Environmental Conditions

Ambient Temperature	23.0 °C
Relative Humidity	24.5 %

2.5.6 Test Method

The EUT was operated with a dummy load connected to the antenna connector rather than an integral antenna. Limitations in the measurement equipment meant that this was necessary to prevent the unit from radiating at full power, overloading the preamplifier.

A preliminary profile of the Spurious Radiated Emissions was obtained by operating the EUT on a remotely controlled turntable within the chamber. Measurements of emissions from the EUT were obtained with the Measurement Antenna in both Horizontal and Vertical Polarisations.

Emissions identified within the range 30MHz – 8GHz were then formally measured using a Peak detector as the worst case.

The measurement of the outside a licensee's frequency band(s) of operation was performed with a resolution bandwidth of 100 kHz.

The limits for outside a licensee's frequency band(s) of operation the power of the Spurious Emissions have been calculated, as shown below using the following formula:

Field Strength of Carrier - $(43 + 10\text{Log}(P))$ dB

On all frequencies between 763 – 775 MHz and 793 – 805 MHz the power of any emission shall be attenuated below the transmitter power, by at least $76 + 10 \log(P)$ dB in a 6.25 kHz band segment, and the measurement was performed with a resolution bandwidth of 10 kHz.

Where:

Field Strength is measured in dB μ V/m

P is measured Transmitter Power in Watts

The measurements were performed at a 3m distance unless otherwise stated.

Determination of Spurious Emission Limit

As the EUT does not have an integral antenna, the field strength of the carrier has been calculated assuming that the power is to be fed to a half-wave tuned dipoles as per 2.1053 (a).

$$E_{(v/m)} = (30 \times G_i \times P_o)^{0.5} / d$$

Where G_i is the antenna gain of ideal half-wave dipoles,
 P_o is the power out of the transceiver in W,
 d is the measurement distance in meter.

Therefore at 3m measurement distance the field strength using the lowest transceiver output power would be:

$$E_{(v/m)} = (30 \times 1.64 \times 4.72)^{0.5} / 3 = 5.08V/m = 134.14 \text{ dB}\mu V/m$$

A value of 4.72W is used for P_o as the lowest transceiver output power is 36.74dBm.

As per 27.53 (c)(1) the spurious emission must be attenuated by $43 + 10\log(P_o)$ dB this gives:

$$43 + 10\log(4.72) = 49.74 \text{ dB}$$

Therefore the limit at 3m measurement distance is:

$$134.14 - 49.74 = 84.4 \text{ dB}\mu V/m$$

As per 27.53 (c)(3) the spurious emission must be attenuated by $76 + 10\log(P_o)$ dB this gives:

$$76 + 10\log(4.72) = 82.74 \text{ dB}$$

Therefore the limit at 3m measurement distance is:

$$134.14 - 82.74 = 51.4 \text{ dB}\mu V/m$$

This limit has been used to determine Pass or Fail for the harmonics measured and detailed in the following results.

The results are shown in the plots below.

2.5.7 Test Results

Note: Only the worst case results plots have been included as all of the emissions are greater than 20dB below the limit. A set of plots have been included to show the measurement system noise floor.

Configuration L-MIMO-SC

Maximum Output Power 37.0dBm per carrier, LTE Bandwidth 5.0MHz

Channel Position	Channel Frequencies
Channel Position B	748.5MHz
Channel Position M	751.0MHz
Channel Position T	753.5MHz

Channel Position B - QPSK / Bandwidth 5.0MHz - 30MHz – 3GHz

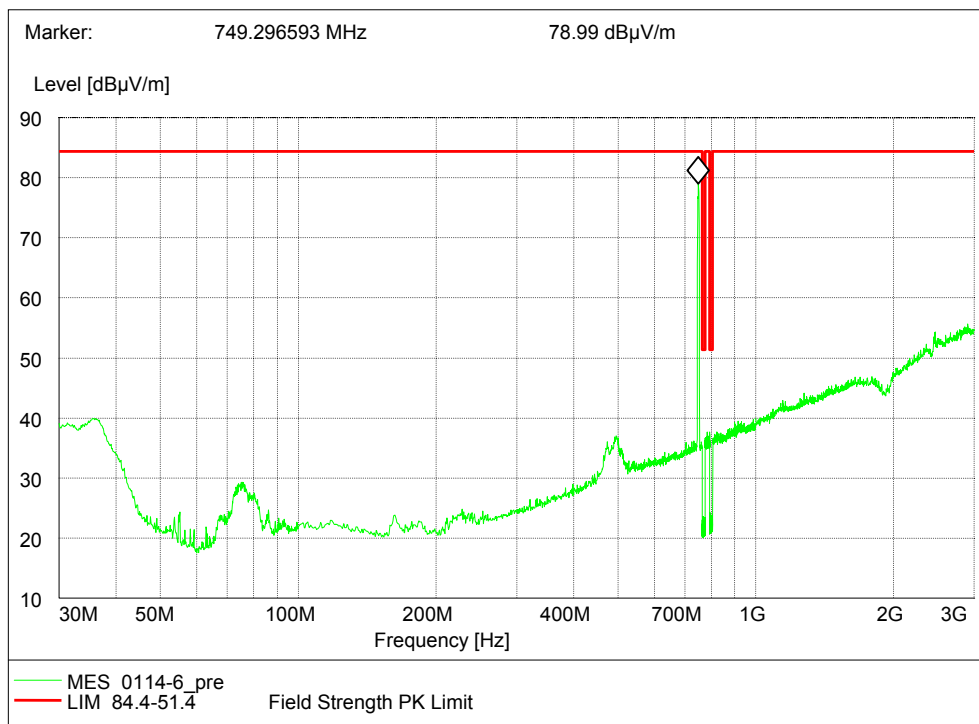

Channel Position B - QPSK / Bandwidth 5.0MHz – 755MHz – 810MHz (Zoom the above plot)

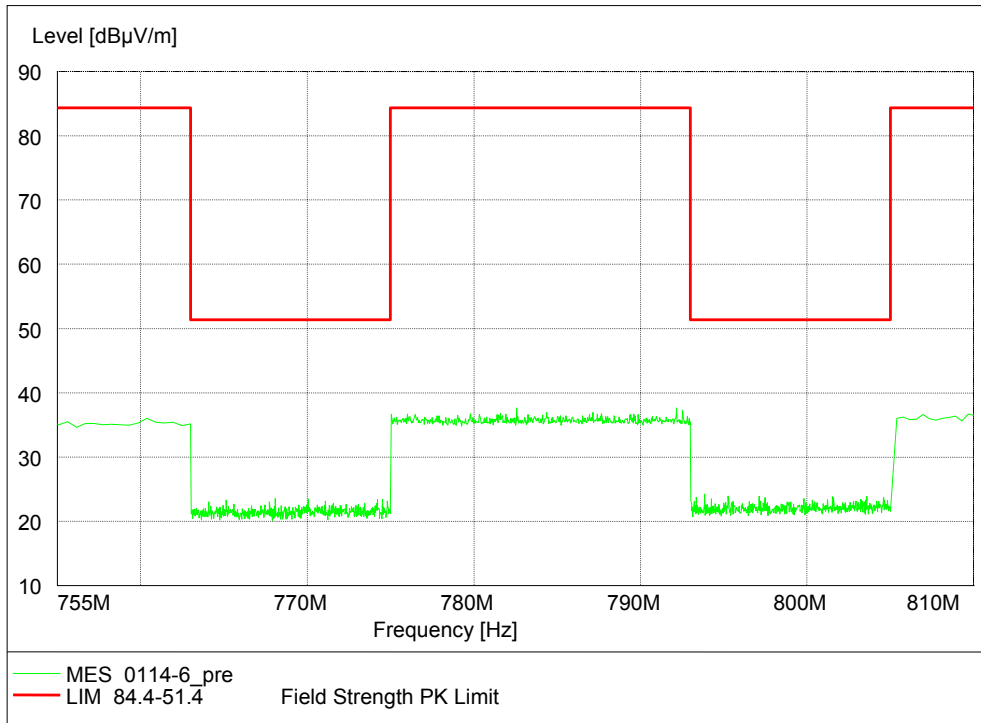

Channel Position B - QPSK / Bandwidth 5.0MHz – 3GHz – 8GHz

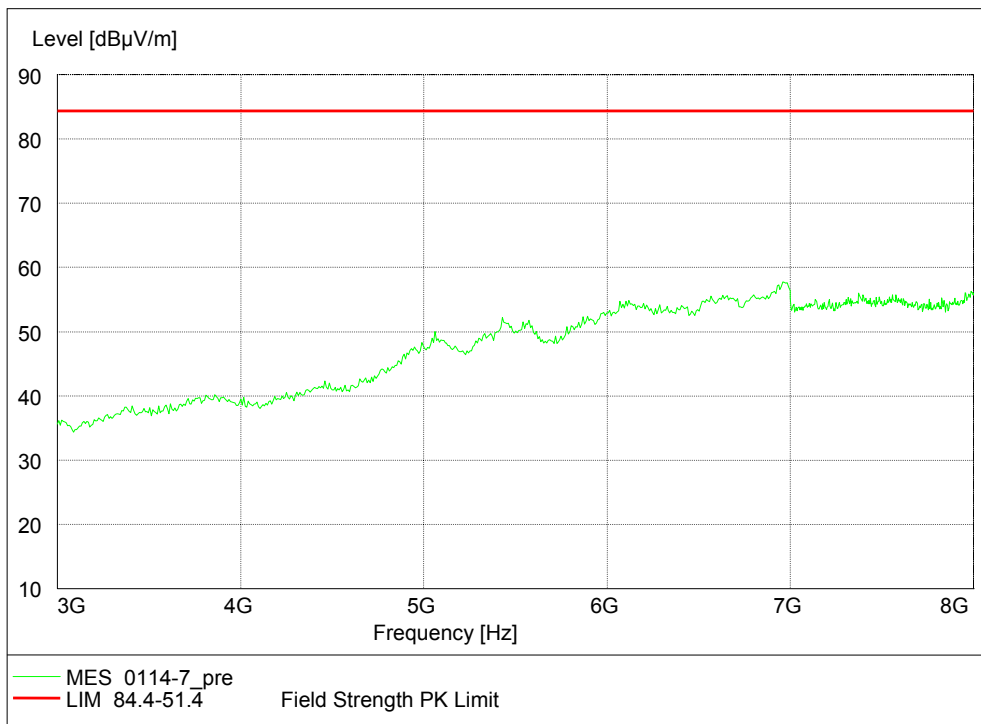

Channel Position M - QPSK

No emissions were detected within 20dB of the limit.

Channel Position T - QPSK

No emissions were detected within 20dB of the limit.

Configuration L-MIMO-SC

Maximum Output Power 37.0dBm per carrier, LTE Bandwidth 10MHz

Channel Position	Channel Frequencies
Channel Position M	751.0MHz

Channel Position M - QPSK

No emissions were detected within 20dB of the limit.

Configuration L-MIMO-MC 1 (2C)

Maximum Output Power 34.0dBm per carrier, LTE Bandwidth 5.0MHz

Channel Position	Channel Frequencies
Channel Position M _{RFBW}	748.5MHz + 753.5MHz

Channel Position M_{RFBW} - QPSK

No emissions were detected within 20dB of the limit.

Limit	-13dBm / 84.4dB μ V/m for outside a licensee's frequency band(s) of operation -46dBm / 51.4dB μ V/m for 763 – 775 MHz and 793 – 805 MHz
-------	--

Remarks

The EUT does not exceed -13dBm / 84.4dB μ V/m and -46dBm / 51.4dB μ V/m at the measured frequencies.

2.6 CONDUCTED SPURIOUS EMISSIONS

2.6.1 Specification Reference

FCC CFR 47 Part 2, Clause 2.1051
FCC CFR 47 Part 27, Clause 27.53 (c)(f)

2.6.2 Equipment Under Test

RBS 6501 B13, KRD 901 113/4, S/N: CB4S376829

2.6.3 Date of Test and Modification State

23 January 2014 - Modification State 0

2.6.4 Test Equipment Used

The major items of test equipment used for the above tests are identified in Section 3.1.

2.6.5 Environmental Conditions

Ambient Temperature	23.5 °C
Relative Humidity	22.5 %

2.6.6 Test Method

In accordance with FCC CFR 47 Part 2, Clause 2.1051, the spurious emissions from the antenna terminal were measured. In accordance with FCC CFR 47 Part 27, Clause 27.53(c), any emissions outside a licensee's frequency band(s) of operation shall be attenuated by at least $43 + 10 \log(P)$, and the measurement was performed with a resolution bandwidth of 1 MHz. On all frequencies between 763 – 775 MHz and 793 – 805 MHz the power of any emission shall be attenuated below the transmitter power, by at least $76 + 10 \log(P)$ dB in a 6.25 kHz band segment, and the measurement was performed with a resolution bandwidth of 10 kHz.

In accordance with FCC CFR 47 Part 27, Clause 27.53(f), in the band 1559–1610 MHz shall be limited to -70 dBW/MHz equivalent isotropically radiated power (EIRP), and the measurement was performed with a resolution bandwidth of 1 MHz.

The EUT was set to transmit at its maximum rated output power. The path loss between the Spectrum Analyser and the EUT was measured with the worst case level being entered as a reference level offset. In accordance with 27.53 (c), peak detector with the trace set to max hold was used. The frequency spectrum was then investigated between 9kHz and 8GHz. Testing was carried out on the bottom, middle and top channels.

For MIMO mode configurations, the limit was adjusted with a correction of -3dB $[10\log 2]$ by using the Measure and Add $10\log(N)$ dB technique according to FCC KDB662911 D01 accounting for simultaneous transmission from antenna ports RF A and RF B.

The measurements were performed on the output connector RF A. Limited complementary measurement were done at output connector RF B to verify identical performance for both transmitter chains in MIMO mode.

2.6.7 Test Results

Configuration L-MIMO-SC

Maximum Output Power 37.0dBm per carrier

Channel Position	Bandwidth	Channel Frequency
Channel Position B	5.0MHz	748.5MHz
Channel Position M	5.0MHz	751.0MHz
	10.0MHz	
Channel Position T	5.0MHz	753.5MHz

Channel Position B - QPSK / Bandwidth 5.0MHz - 9kHz – 1GHz

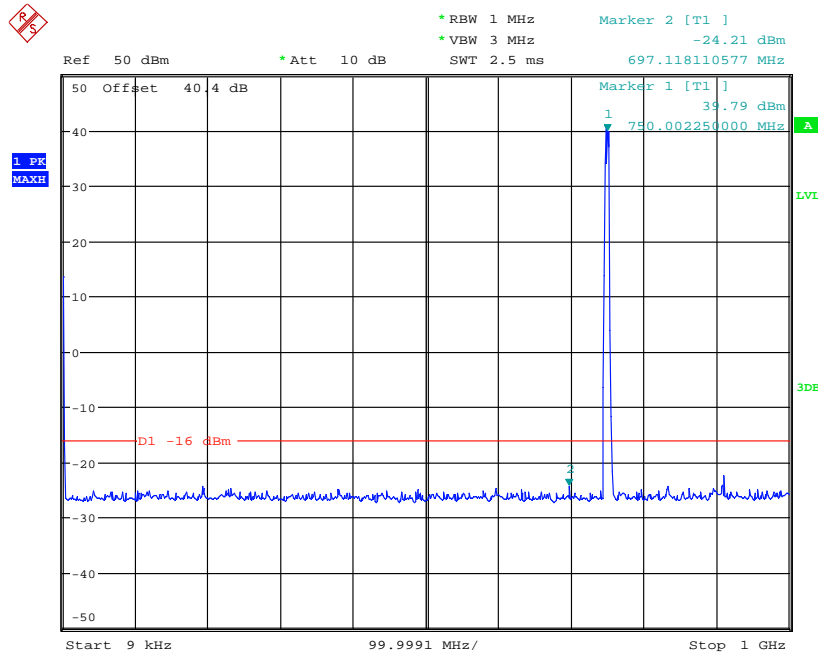

Date: 23.JAN.2014 13:31:24

Channel Position B - QPSK / Bandwidth 5.0MHz - 1GHz – 8GHz

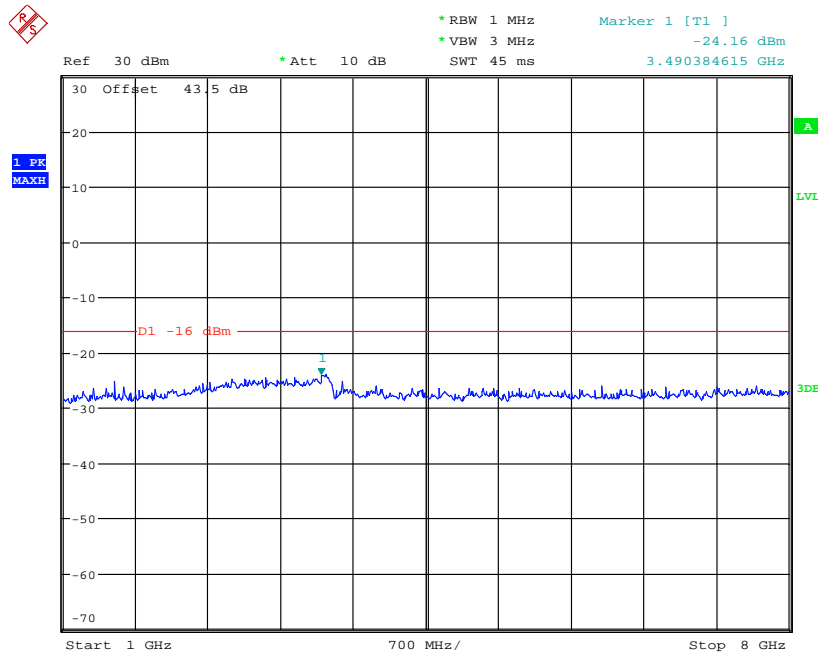

Date: 23.JAN.2014 13:33:06

Channel Position B - QPSK / Bandwidth 5.0MHz - 763MHz – 805MHz

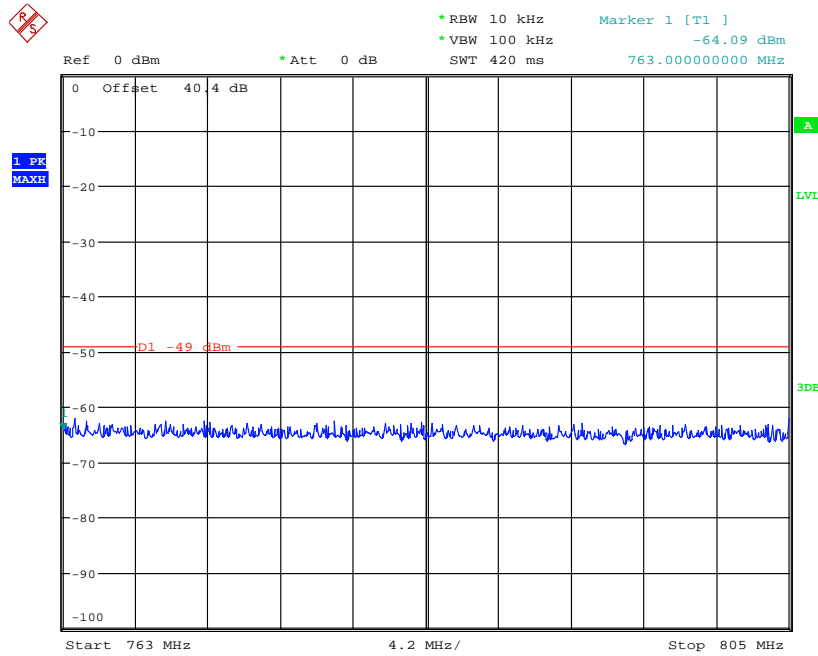

Date: 23.JAN.2014 13:37:34

Channel Position B - QPSK / Bandwidth 5.0MHz - 1.559GHz – 1.610GHz

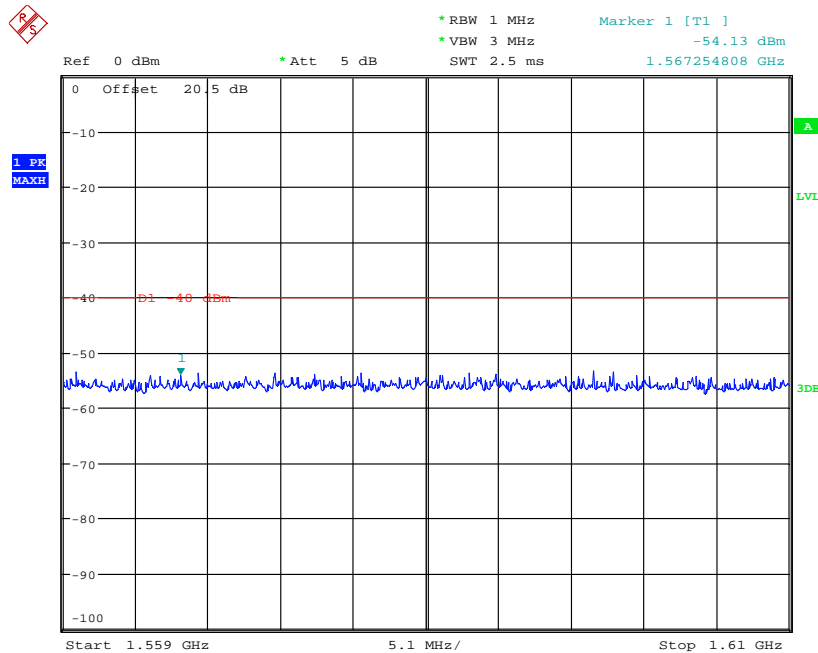

Date: 23.JAN.2014 15:14:19

Note: The limi3 dB [10log(2)] according to “measure and add 10log(N_{ANT})” of FCC KDB662911 D01 Multiple Transmitter Output V02

Channel Position M - QPSK / Bandwidth 5.0MHz - 9kHz – 1GHz

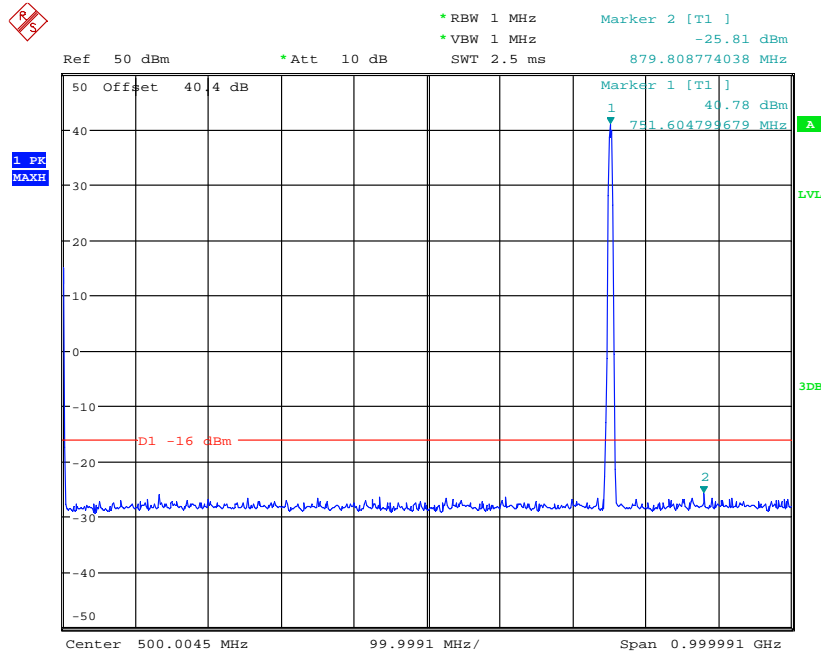

Date: 13.JAN.2014 15:24:56

Channel Position M - QPSK / Bandwidth 5.0MHz - 1GHz – 8GHz

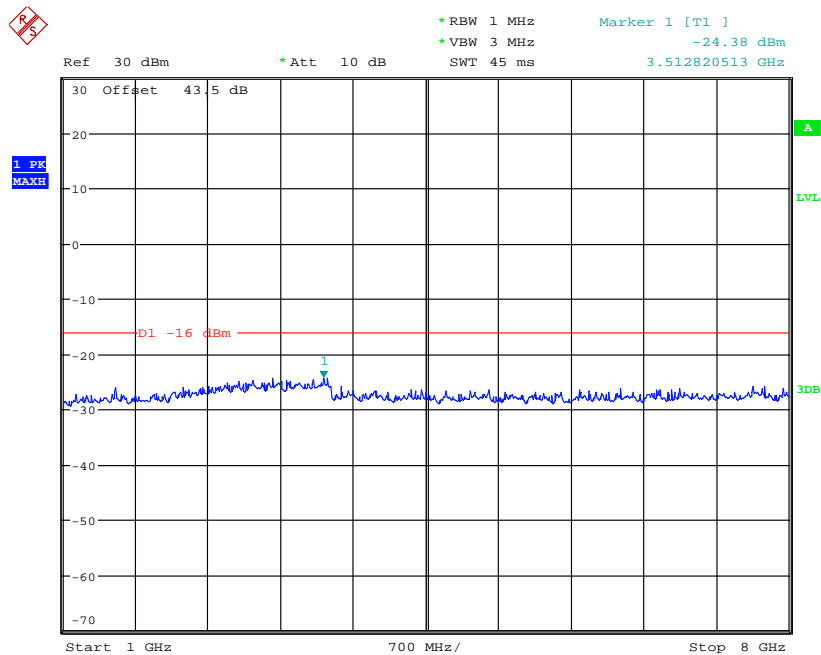

Date: 23.JAN.2014 11:15:43

Channel Position M - QPSK / Bandwidth 5.0MHz - 763MHz – 805MHz

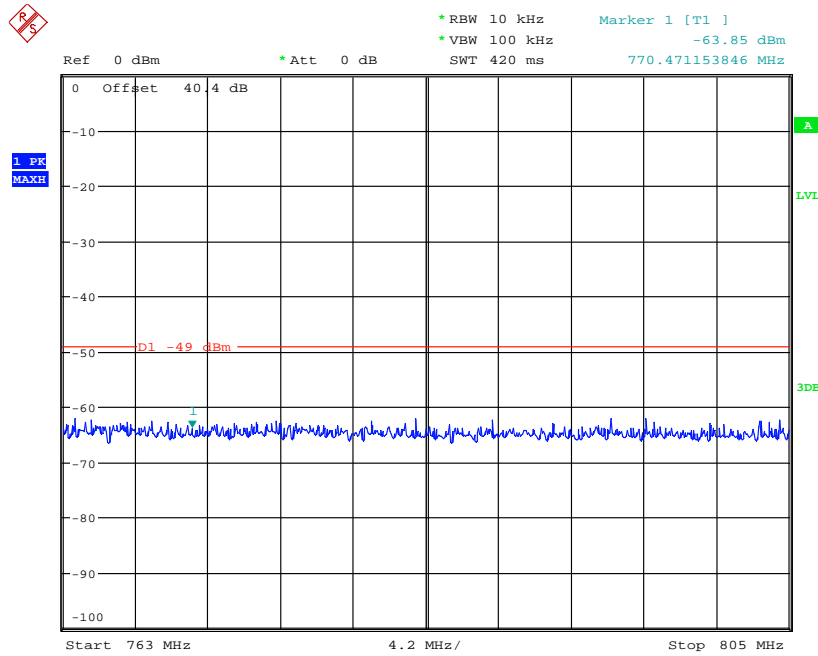

Date: 23.JAN.2014 11:13:45

Channel Position M - QPSK / Bandwidth 5.0MHz - 1.559GHz – 1.610GHz

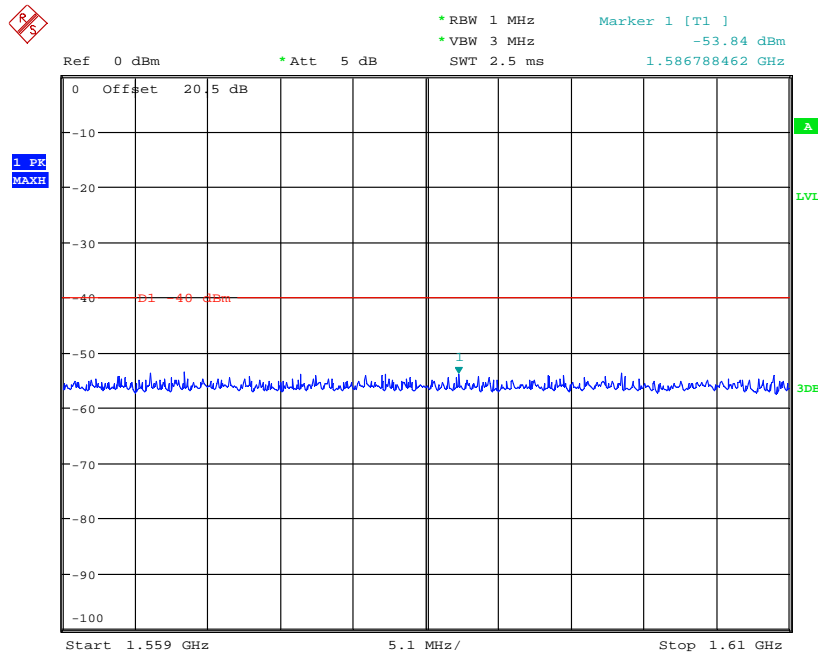

Date: 23.JAN.2014 15:16:17

Note: The limit should be reduced by 3 dB [10log(2)] to -43 dBm according to “measure and add 101og(N_{ANT})” of FCC KDB662911 D01 Multiple Transmitter Output V02

Channel Position M - QPSK / Bandwidth 10.0MHz - 9kHz – 1GHz

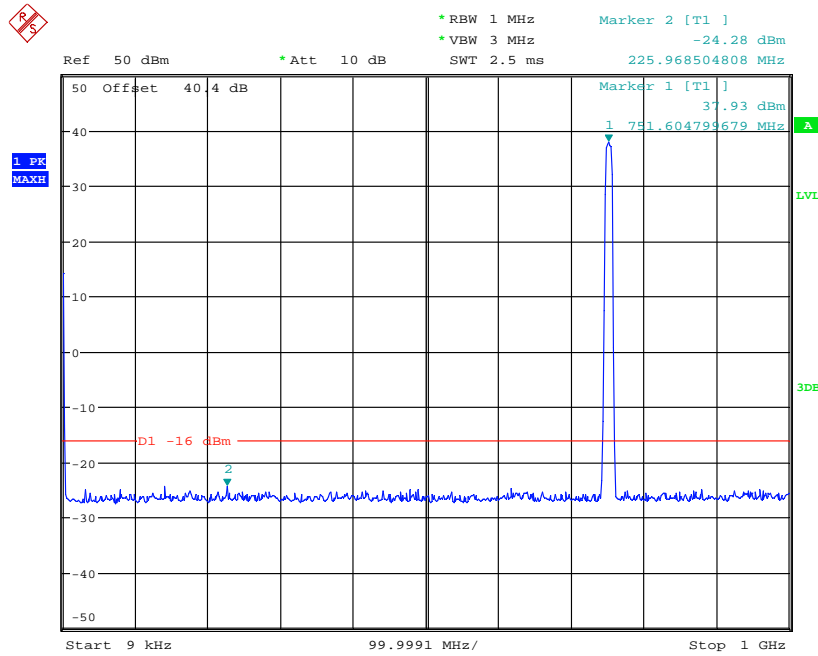

Date: 23.JAN.2014 14:09:26

Channel Position M - QPSK / Bandwidth 10.0MHz - 1GHz – 8GHz

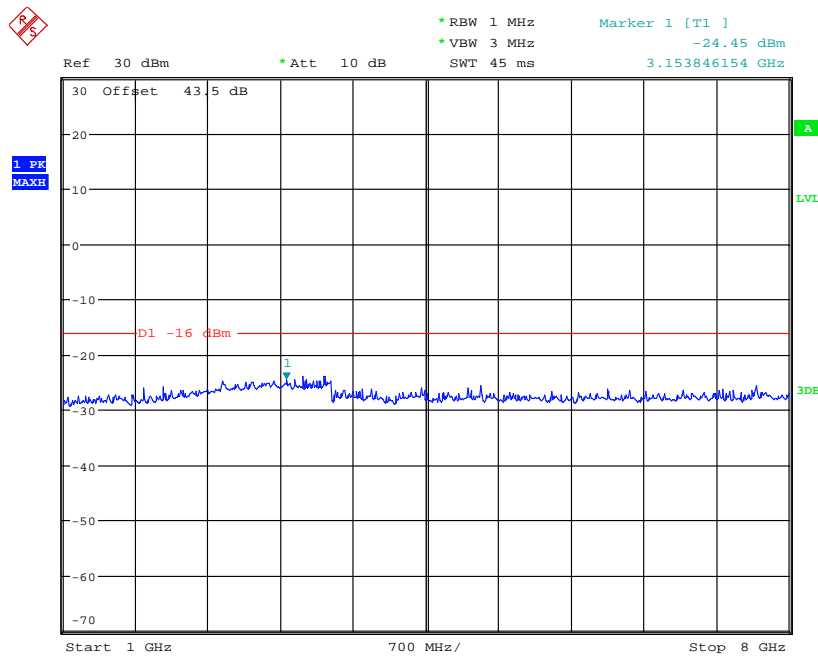

Date: 23.JAN.2014 14:10:32

Channel Position M - QPSK / Bandwidth 10.0MHz - 763MHz – 805MHz

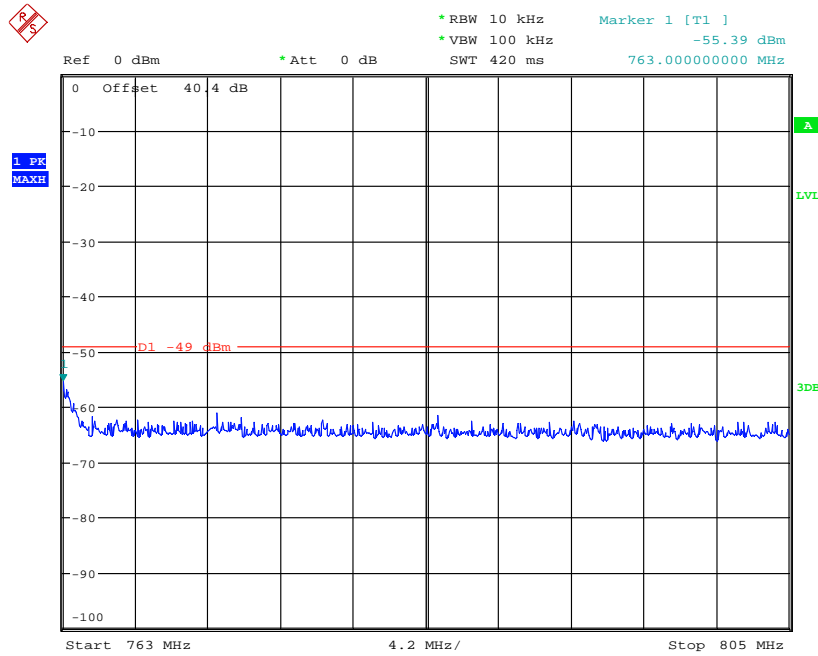

Date: 23.JAN.2014 14:14:19

Channel Position M - QPSK / Bandwidth 10.0MHz - 1.559GHz – 1.610GHz

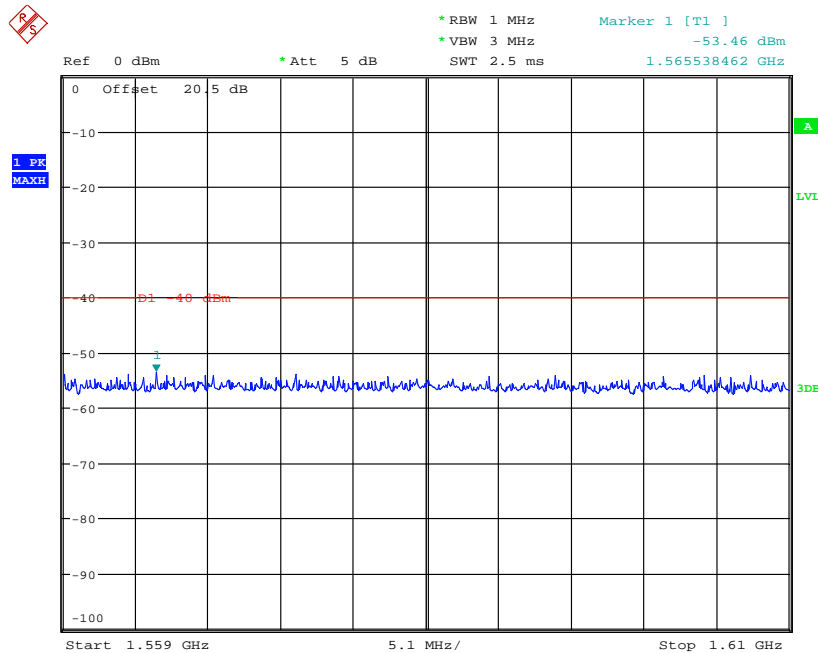

Date: 23.JAN.2014 15:18:34

Note: The limit should be reduced by 3 dB [10log(2)] to -43 dBm according to “measure and add 101og(N_{ANT})” of FCC KDB662911 D01 Multiple Transmitter Output V02

Channel Position T - QPSK / Bandwidth 5.0MHz - 9kHz – 1GHz

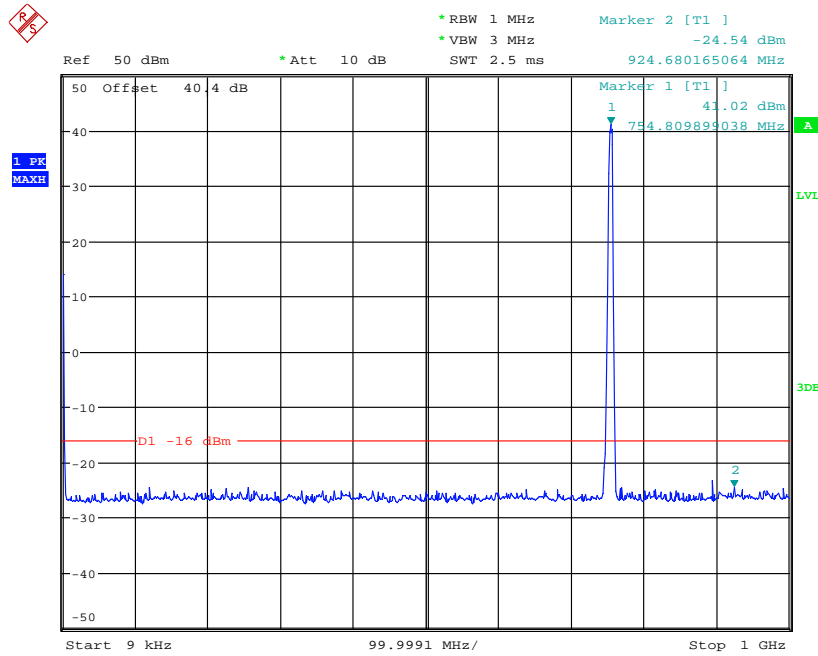

Date: 23.JAN.2014 13:46:48

Channel Position T - QPSK / Bandwidth 5.0MHz - 1GHz – 8GHz

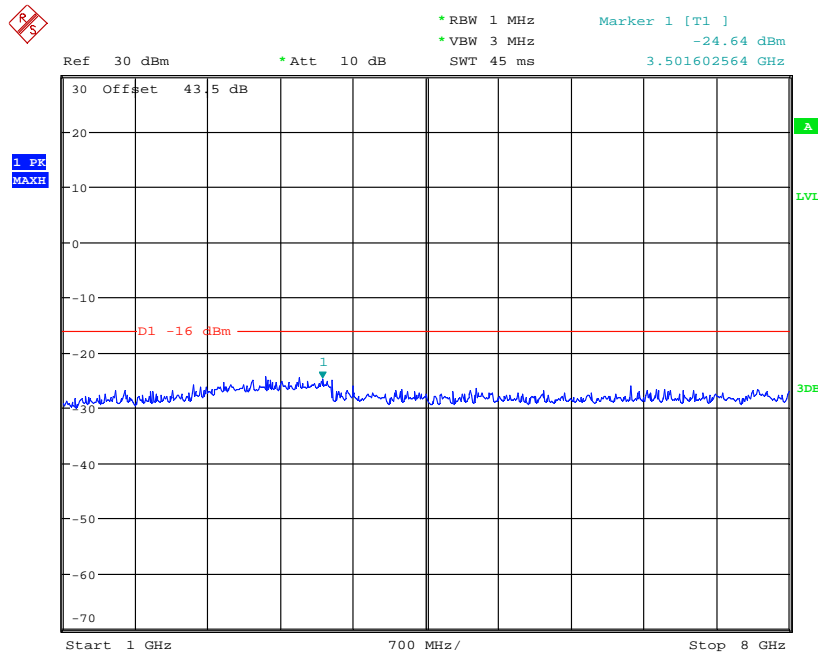

Date: 23.JAN.2014 13:44:42

Channel Position T - QPSK / Bandwidth 5.0MHz - 763MHz – 805MHz

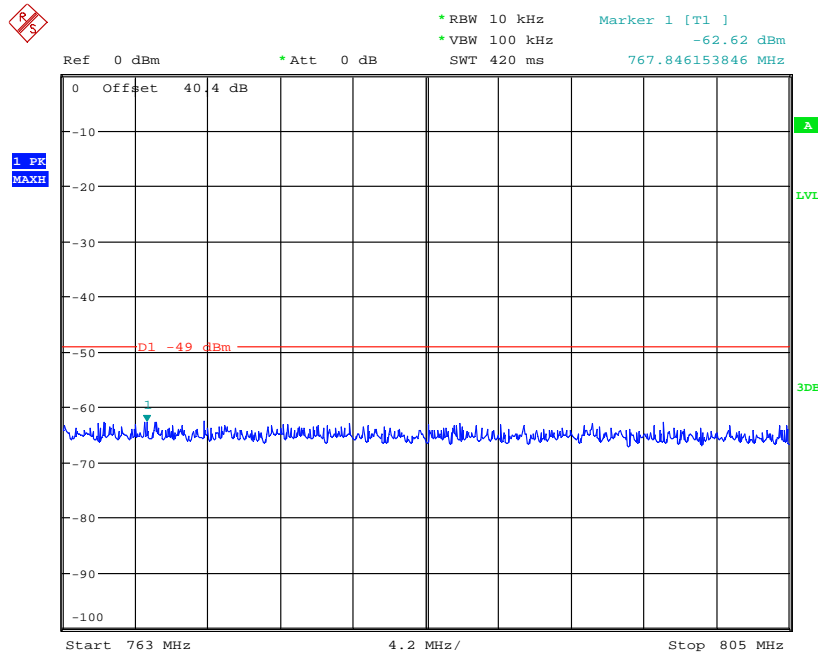

Date: 23.JAN.2014 13:41:11

Channel Position T - QPSK / Bandwidth 5.0MHz - 1.559GHz – 1.610GHz

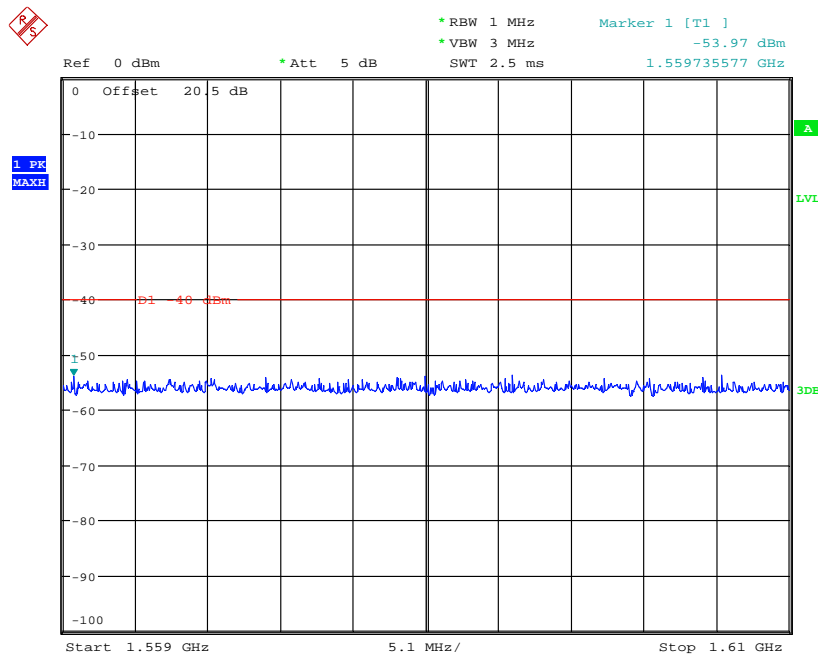

Date: 23.JAN.2014 15:17:28

Note: The limit should be reduced by 3 dB [10log(2)] to -43 dBm according to “measure and add 101og(N_{ANT})” of FCC KDB662911 D01 Multiple Transmitter Output V02

Configuration L-MIMO-MC 1 (2C)

Maximum Output Power 34.0dBm per carrier

Channel Position	Bandwidth	Channel Frequency
Channel Position M_{RFBW}	5.0MHz	748.5MHz + 753.5MHz

Channel Position M_{RFBW} - QPSK / Bandwidth 5.0MHz - 9kHz – 1GHz

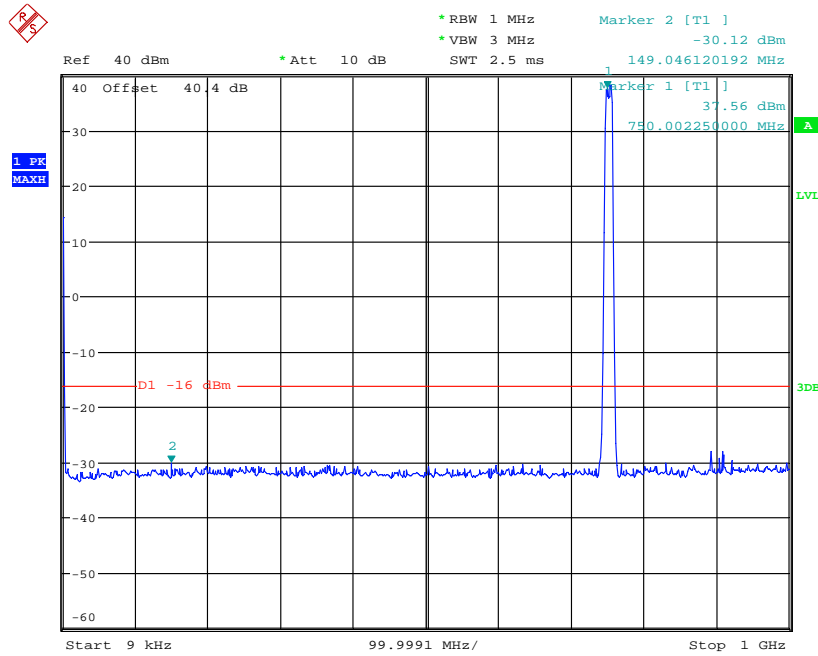

Date: 23.JAN.2014 14:20:12

Channel Position M_{RFBW} - QPSK / Bandwidth 5.0MHz - 1GHz – 8GHz

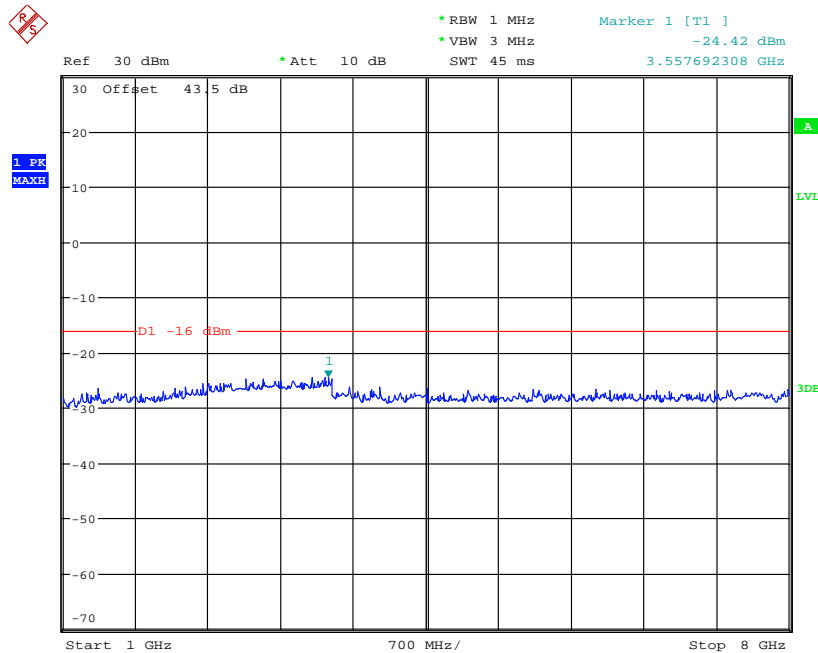

Date: 23.JAN.2014 14:21:06

Channel Position M_{RFBW} - QPSK / Bandwidth 5.0MHz - 763MHz – 805MHz

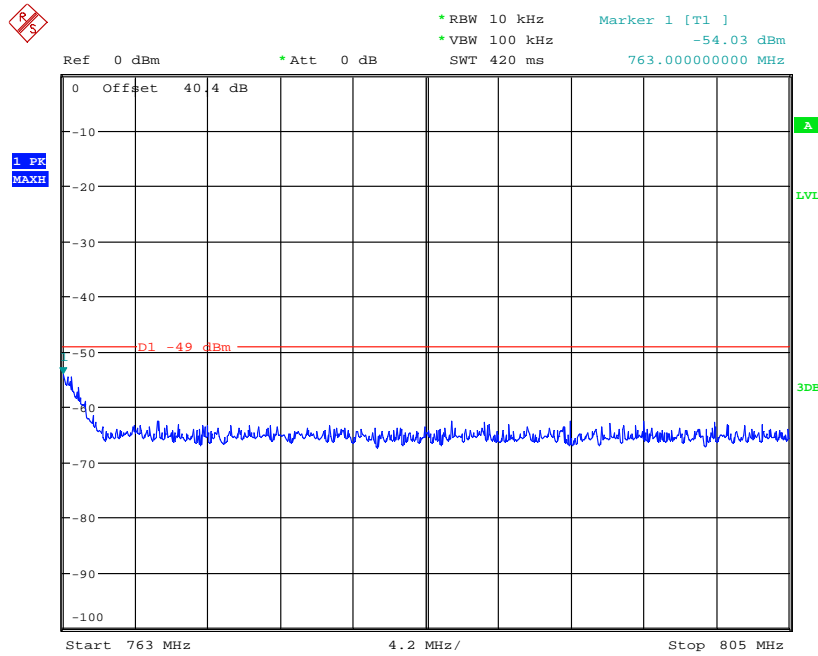

Date: 23.JAN.2014 14:18:48

Channel Position M_{RFBW} - QPSK / Bandwidth 5.0MHz - 1.559GHz – 1.610GHz

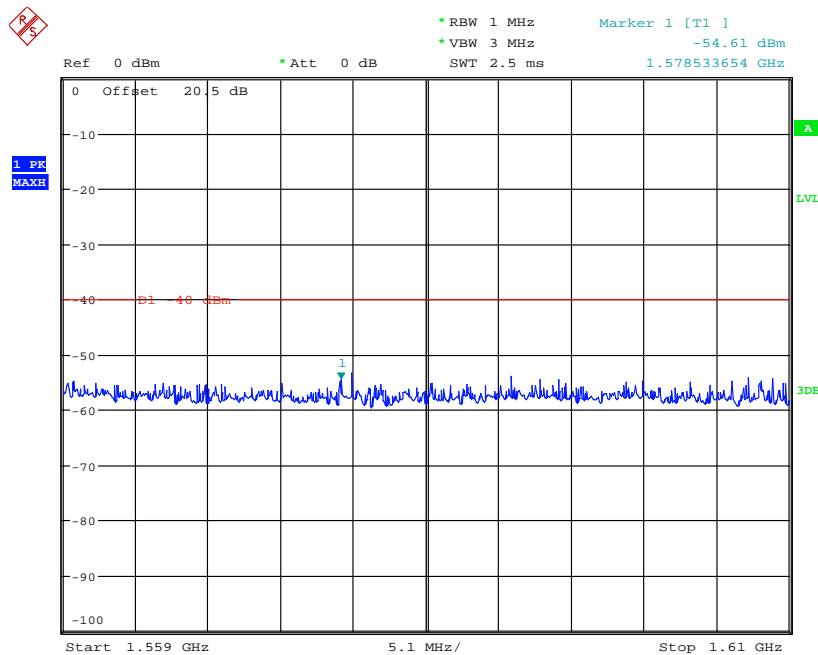

Date: 23.JAN.2014 15:08:15

Note: The limit should be reduced by 3 dB $[10\log(2)]$ to -43 dBm according to “measure and add $10\log(N_{ANT})$ ” of FCC KDB662911 D01 Multiple Transmitter Output V02

Limit	-13dBm for outside a licensee's frequency band(s) of operation -46dBm for 763MHz – 805MHz -40dBm for 1559 MHz – 1610MHz
-------	---

2.7 FREQUENCY STABILITY

2.7.1 Specification Reference

FCC CFR 47 Part 2, Clause 2.1055
FCC CFR 47 Part 27, Clause 27.54

2.7.2 Equipment Under Test

RBS 6501 B13, KRD 901 113/1, S/N: CB4S430808
RBS 6501 B13, KRD 901 113/4, S/N: CB4S376829

2.7.3 Date of Test and Modification State

22 January 2014 - Modification State 0

2.7.4 Test Equipment Used

The major items of test equipment used for the above tests are identified in Section 3.1.

2.7.5 Environmental Conditions

Ambient Temperature	22.5 °C
Relative Humidity	23.5 %

2.7.6 Test Method

Frequency Error – Temperature Variation

The EUT was tested over the temperature range -30°C to +50°C in 10°C steps with -48 VDC Power Supply. At each temperature step, the Base Station was configured to transmit a 5 MHz LTE carrier with QPSK modulation at maximum power on the middle channel of the operating band. After achieving thermal balance, the averages of 200 transmission bursts were measured and the result recorded.

Frequency Error – Voltage Variation

The EUT was tested at the supplied voltages varied from 85 to 115 percent of the nominal values of both -48 VDC and 120 VAC power supplies. At +20°C, the Base Station was configured to transmit a 5 MHz LTE carrier with QPSK modulation at maximum power on the middle channel of the operating band. The average of 200 transmission bursts was measured and the result recorded.

Test Results

Configuration L-MIMO-SC

Maximum Output Power 37.0dBm per carrier, Channel Bandwidth 5MHz

Supply Voltage DC (V)	Temperature	Frequency Stability (Hz)
		Channel Position M (751.0MHz)
-48.0	-30°C	+10.66
	-20°C	-11.12
	-10°C	+11.13
	0°C	-10.75
	+10°C	-11.08
	+20°C	+10.86
	+30°C	+11.28
	+40°C	-10.76
	+50°C	+11.29

Configuration L-MIMO-SC

Maximum Output Power 37.0dBm per carrier, Channel Bandwidth 5MHz

Supply Voltage DC (V)	Temperature	Frequency Stability (Hz)
		Channel Position M (751.0MHz)
-40.8 V	+20°C	-9.59
-48.0 V		+10.86
-55.2 V		+11.22

Supply Voltage AC (V)	Temperature	Frequency Stability (Hz)
		Channel Position M (751.0MHz)
-102.0 V	+20°C	-7.23
-120.0 V		-7.05
-138.0 V		+7.03

Limit	$\pm (0.05\text{ppm or } +12 \text{ Hz) or } \pm 49.55 \text{ Hz}^1$
-------	--

Remarks

¹ Limit according to 3GPP TS 36.141 V9.6.0.

The frequency stability of the EUT is sufficient to keep it within the authorised frequency ranges at any temperature and voltage interval across the measured range.



Product Service

SECTION 3

TEST EQUIPMENT USED

3.1 TEST EQUIPMENT USED

List of absolute measuring and other principal items of test equipment.

Instrument	Manufacturer	Type No.	TE No.	Calibration Period (months)	Calibration Due
Maximum Average Output Power and Peak to Average Ratio - Conducted					
Network Analyzer	Agilent	8720D	US36140166	12	17-Nov-2014
Power Meter	Rohde & Schwarz	NRP	101593	12	04-Aug-2014
Power Sensor	Rohde & Schwarz	NRP-Z51	102123	12	04-Aug-2014
Spectrum Analyser	Rohde & Schwarz	FSQ26	200687	12	01-Apr-2014
40dB Attenuator	Aeroflex / Weinschel	48-40-43-LIM	BR5020	-	O/P MON
Load	Shanghai Huaxiang	TFE100	09121647	-	O/P MON
DC Power Supply	Dahua	DH1716A-10	1000303181	-	O/P MON
Maximum Average Output Power - Radiated					
EMI Receiver	Rohde & Schwarz	ESI 40	100015	12	19-Aug-2014
Ultra log test antenna	Rohde & Schwarz	HL562	100167	12	19-Aug-2014
Double-Ridged Wave-guide Horn Antenna	Rohde & Schwarz	HF 906	100029	12	19-Aug-2014
Pyramidal Horn Antenna	EMCO	9120E	391	12	19-Aug-2014
Antenna master	Frankonia	MA 260	-	-	19-Aug-2014
Semi Anechoic Chamber	Frankonia	23.18m×16.88m×9.60m	-	12	19-Aug-2014
Single Generator	Rohde & Schwarz	SMR40	100152	12	19-Aug-2014
40dB Attenuator	Aeroflex / Weinschel	48-40-43-LIM	BR5020	-	O/P MON
DC Power Supply	Dahua	DH1716-5D	2007060047	-	O/P MON
Digital Multimeter	FLUKE	179	91820401	12	24-Dec-2014
Thermo-hygrometer	AZ Instruments	8705	9151655	12	12-Dec-2014
Occupied Bandwidth					
Network Analyzer	Agilent	8720D	US36140166	12	17-Nov-2014
Spectrum Analyser	Rohde & Schwarz	FSQ26	100253	12	04-Aug-2014
40dB Attenuator	Aeroflex / Weinschel	48-40-43-LIM	BR5020	-	O/P MON
Load	Shanghai Huaxiang	TFE100	09121647	-	O/P MON
DC Power Supply	Dahua	DH1716A-10	1000303181	-	O/P MON
Band Edge					
Network Analyzer	Agilent	8720D	US36140166	12	17-Nov-2014
Spectrum Analyser	Rohde & Schwarz	FSQ26	200687	12	01-Apr-2014
40dB Attenuator	Aeroflex / Weinschel	48-40-43-LIM	BR5020	-	O/P MON
Load	Shanghai Huaxiang	TFE100	09121647	-	O/P MON
DC Power Supply	Dahua	DH1716A-10	1000303181	-	O/P MON
Conducted Spurious Emission					
Network Analyzer	Agilent	8720D	US36140166	12	17-Nov-2014
Spectrum Analyser	Rohde & Schwarz	FSQ26	200687	12	01-Apr-2014
40dB Attenuator	Aeroflex / Weinschel	48-40-43-LIM	BR5020	-	O/P MON
20dB Attenuator	Shanghai Huaxiang	T:54451395	090722015	-	O/P MON
Load	Shanghai Huaxiang	TFE100	09121647	-	O/P MON
DC Power Supply	Dahua	DH1716A-10	1000303181	-	O/P MON

Instrument	Manufacturer	Type No.	TE No.	Calibration Period (months)	Calibration Due
Radiated Spurious Emissions					
Load	Shanghai Huaxiang	TF150-3	06081410	-	O/P MON
Load	Shanghai Huaxiang	TF100	09121614	-	O/P MON
EMI Receiver	Rohde & Schwarz	ESI 40	100015	12	19-Aug-2014
Ultra log test antenna	Rohde & Schwarz	HL562	100167	12	19-Aug-2014
Double-Ridged Wave-guide Horn Antenna	Rohde & Schwarz	HF 906	100029	12	19-Aug-2014
Pyramidal Horn Antenna	EMCO	3160-09	760840	12	19-Aug-2014
Pyramidal Horn Antenna	EMCO	3160-10	808234	12	19-Aug-2014
Antenna master	Frankonia	MA 260	-	-	19-Aug-2014
Relay Switch Unit	Rohde & Schwarz	331.1601.31	338965002	-	TU
Semi Anechoic Chamber	Frankonia	23.18m×16.88m×9.60m	-	12	19-Aug-2014
DC Power Supply	Dahua	DH1716-5D	2007060047	-	O/P MON
Digital Multimeter	FLUKE	179	91820401	12	24-Dec-2014
Thermo-hygrometer	AZ Instruments	8705	9151655	12	12-Dec-2014
Frequency Stability					
Network Analyzer	Agilent	8720D	US36140166	12	17-Nov-2014
Spectrum Analyser	Rohde & Schwarz	FSQ26	200687	12	01-Apr-2014
40dB Attenuator	Aeroflex / Weinschel	48-40-43-LIM	BR5020	-	O/P MON
Climate Chamber	Shang Hai Zenda	ZTH100U	10080065	-	O/P MON
Load	Shanghai Huaxiang	TFE100	09121647	-	O/P MON
DC Power Supply	Dahua	DH1716A-10	1000303181	-	O/P MON
AC Power Supply	Chroma	6530	ETD/L710	12	O/P MON
Digital Multimeter	FLUKE	179	91820401	12	24-Dec-2014
Thermo-hygrometer	AZ Instruments	8705	9151655	12	12-Dec-2014

N/A – Not Applicable

OP MON – Output Monitored with Calibrated Equipment

3.2 MEASUREMENT UNCERTAINTY

For a 95% confidence level, the measurement uncertainties for defined systems are:-

Test Discipline	Frequency / Parameter	MU
Conducted Maximum Peak Output Power	30MHz to 10GHz Amplitude	0.5dB*
ERP	30MHz to 18GHz Amplitude	2.6dB
Conducted Emissions	30MHz to 40GHz Amplitude	3.0dB*
Frequency stability	30MHz to 2GHz	$<\pm 1 \times 10^{-7}$
Radiated Emissions, Bilog Antenna, AOATS	30MHz to 1GHz Amplitude	5.1dB*
Radiated Emissions, Horn Antenna, AOATS	1GHz to 40GHz Amplitude	6.3dB*
Worst case error for both Time and Frequency measurement 12 parts in 10^6		

* In accordance with CISPR 16-4



Product Service

SECTION 5

ACCREDITATION, DISCLAIMERS AND COPYRIGHT

4.1 ACCREDITATION, DISCLAIMERS AND COPYRIGHT



This report relates only to the actual item/items tested.

Our UKAS Accreditation does not cover opinions and interpretations and any expressed are outside the scope of our UKAS Accreditation.

Results of tests not covered by our UKAS Accreditation Schedule are marked NUA (Not UKAS Accredited).

© 2014 TÜV SÜD Product Service