



Add value.
Inspire trust.



Report On

FCC and ISED Testing of the
Ericsson Radio 4490HP 44B5 44B12A C, KRC 161 981/3 ESS, LTE,
NR, LTE and NB-IoT IB, NB-IoT GB, NR and NB-IoT IB (850 MHz)
Base Station in accordance with FCC CFR 47 Part 2: 2021,
FCC CFR 47 Part 22: 202, ISED RSS-GEN: Issue 5: March 2019
Amendment 1, 2021 Amendment 2, ISED RSS-132: Issue 4: 2023

COMMERCIAL-IN-CONFIDENCE

FCC: TA8AKRC161981

IC: 287AB-AS161981

PREPARED BY

APPROVED BY

DATED

Maggie Whiting
Key Account Manager

Steve Scarfe
Authorised Signatory

05 April 2023

Document 75957662 Report 01 Issue 1

April-2023



CONTENTS

Section	Page No
1	REPORT INFORMATION 2
1.1	Report Details 3
1.2	Brief Summary of Results 4
1.3	Test Rationale..... 5
1.4	Configuration Description 6
1.5	Declaration of Build Status 7
1.6	Product Information 9
1.7	Test Setup 10
1.8	Deviation From The Standard 12
1.9	Modification Record 12
1.10	Additional Information 13
2	TEST DETAILS 14
2.1	Maximum Peak Output Power and Peak to Average Ratio - Conducted..... 15
2.2	Occupied Bandwidth..... 46
2.3	Band Edge 82
2.4	Transmitter Spurious Emissions 108
2.5	Frequency Stability 155
3	TEST EQUIPMENT USED 157
3.1	Test Equipment Used 158
3.2	Measurement Uncertainty 160
3.3	Measurement Software Used 161
4	ACCREDITATION, DISCLAIMERS AND COPYRIGHT 162
4.1	Accreditation, Disclaimers and Copyright..... 163
ANNEX A	Module Lists.....A.2



SECTION 1

REPORT INFORMATION



1.1 REPORT DETAILS

Manufacturer	Ericsson
Address	Torshamnsgatan 23 Kista SE-16480 Stockholm Sweden
Product Name & Product Number	Radio 4490HP 44B5 44B12A C - KRC 161 981/3
IC Model Name	AS161981
Serial Number(s)	E23E439818
Software Version	CXP2021113/1_R16A470
Hardware Version	R1B
Non-Tested Variant (See Section 1.10 Additional Information)	Radio 4490HP 44B5 44B12A C - KRC 161 981/31
Test Specification/Issue/Date	FCC CFR 47 Part 2: 2021, FCC CFR 47 Part 22: 202, ISED RSS-GEN: Issue 5: March 2019 Amendment 1, 2021 Amendment 2, ISED RSS-132: Issue 4: 2023
Test Plan	General RA FCC-ISED Test Plan for Radio 4490HP B5B12A_H
Start of Test	08-March-2023
Finish of Test	31-March-2023
Name of Engineer(s)	Ashok Kumar
Related Document(s)	KDB 971168 D01 v02r02 KDB 662911 D01 v02r01 ICES-003: Issue 7 (2020-10) ANSI C63.26-2015 SRSP-503 Issue 08:January 2023

ENGINEERING STATEMENT

The measurements shown in this report were made in accordance with the procedures described on test pages. All reported testing was carried out on a sample equipment to demonstrate compliance with FCC CFR 47 Part 2: 2021, FCC CFR 47 Part 22: 202, ISED RSS-GEN: Issue 5: March 2019 Amendment 1, 2021 Amendment 2, ISED RSS-132: Issue 4: 2023. The sample tested was found to comply with the requirements defined in the applied rules.

Test Engineer(s);

Ashok Kumar



1.2 BRIEF SUMMARY OF RESULTS

The tests that have been selected are detailed in the customer Test Plan as defined in section 1.1 of this report. The Test Plan is based on the TÜV SÜD FCC Test Plan Rationale, available on request.

A brief summary of results for each configuration, in accordance with FCC CFR 47 Part 2, FCC CFR 47 Part 22, ISED RSS-GEN and ISED RSS-132 is shown below.

Section	Specification Clause				Test Description	Result
	FCC CFR 47 Part 2	FCC CFR 47 Part 22	RSS-GEN	ISED RSS-132		
2.1	2.1046	22.913 (a)	-	5.4	Maximum Peak Output Power and Peak to Average Ratio - Conducted	Pass
2.2	2.1049	22.917 (b)	6.7	5.5	Occupied Bandwidth	Pass
2.3	2.1051	22.917(b)	-	5.5	Band Edge	Pass
2.4	2.1051	22.917(b)	6.13	5.5	Transmitter Spurious Emissions	Pass
2.5	2.1055	22.355	6.11	5.3	Frequency Stability	Pass

Testing in this Report covers only B5 (850 MHz)

For additional configurations and test cases not contained within this test report, refer to the following reports:

TÜV SÜD Document 75957662 Report 02 - Radio 4490HP 44B5 44B12A C – B12A (700MHz) and Multiband B12A + B5 only.

TÜV SÜD Document 7595662 Report 03 - Radio 4490HP 44B5 44B12A C – B5 (8500MHz) – ESS only.

TÜV SÜD Document 7595662 Report 04 - Radio 4490HP 44B5 44B12A C – B12A (700MHz) – ESS only.



1.3 TEST RATIONALE

The tests that have been selected are detailed in the customer Test Plan as defined in section 1.1 of this report. The Test Plan is based on the TÜV SÜD FCC Test Plan Rationale, available on request.



1.4 CONFIGURATION DESCRIPTION

Config No	RAT	No Of carriers	Carrier Bandwidth	Carrier Frequency Configuration (MHz)				
				Channel position B (MHz)	Channel position M (MHz)	Channel position T (MHz)	Power (dBm) per Carrier	
1	LTE	1	5.0 MHz	871.5	881.5	891.5	47.8	
			10.0 MHz	874.0	881.5	889.0	47.8	
2		2	5.0 MHz	-	871.5+891.5	-	44.8	
			10.0 MHz	-	874.0+889.0	-	44.8	
3		5	5.0 MHz	-	871.5+876.5+881.5+886.5+891.5	-	40.8	
4		NR	1	5.0 MHz 15 kHz SCS	871.5	881.5	891.5	47.8
				10.0 MHz 30 kHz SCS	874.0	881.5	889.0	47.8
				15.0 MHz 30 kHz SCS	876.5	881.5	886.5	47.8
				20.0 MHz 30 kHz SCS	879.0	881.5	884.0	47.8
				25.0 MHz 30 kHz SCS	-	881.5(B.M.T)	-	47.8
5			2	5.0 MHz 15 kHz SCS	-	871.5+891.5	-	44.8
	10.0 MHz 30 kHz SCS			-	874.0+889.0	-	44.8	
6	5		5.0 MHz 15 kHz SCS	-	871.5+876.5+881.5+886.5+891.5	-	40.8	
7	LTE+NR		2	5.0 MHz (LTE) + 15.0 MHz 30 kHz SCS (NR)	-	(NR) 876.5 + (LTE) 891.5	-	44.8
8			3	5.0 MHz(LTE) + 5.0 MHz (LTE) + 15.0 MHz 30 kHz SCS (NR)	-	(NR) 876.5 + (LTE) 886.5 + (LTE) 891.5	-	43
9	NR NB-IoT IB		1	5.0 MHz 15 kHz SCS	871.5	881.5	891.5	47.8
		10.0 MHz 30 kHz SCS		874.0	881.5	889.0	47.8	
		15.0 MHz 30 kHz SCS		876.5	881.5	886.5	47.8	
		20.0 MHz 30 kHz SCS		879.0	881.5	884.0	47.8	
		25.0 MHz 30 kHz SCS		881.5	881.5	881.5	47.8	
10	LTE NB-IoT IB	1	5.0 MHz	871.5	881.5	891.5	47.8	
11	LTE NB-IoT GB	1	10.0 MHz	874.0	881.5	889.0	47.8	



1.5 DECLARATION OF BUILD STATUS

Equipment Description		
Technical Description:	Multi standard Radio 4490HP 44B5 44B12A C 4Tx/4Rx	
Manufacturer:	Ericsson AB	
Model:	Radio 4490HP 44B5 44B12A C	
Part Number:	KRC161981/3 and Variant KRC161981/31	
Hardware Version:	R1B	
Software Version:	CXP2021113/1_R16A470	
FCC ID of the product under test	TA8AKRC161981	
IC ID of the product under test	287AB-AS161981	
HVIN:	AS161981	
Intentional Radiators		
RAT	LTE +NB-IoT(IB, GB) SCS:15kHz	NR + NB-IoT(IB) ,SCS:15kHz, 30kHz
Frequency Range (MHz to MHz) B5	DL: 869 - 894 MHz, UL 824-849 MHz	DL: 869 - 894 MHz, UL 824-849 MHz
Frequency Range (MHz to MHz) B12A	DL: 729 - 745 MHz, UL 699- 715MHz	DL: 729 - 745 MHz, UL 699-715MHz
Conducted Declared Output Power (dBm)	47,8 Max output power per port/ 60W 50,8 Max output power multi band per port/120W 56.81Max output power per Radio 480W.	47,8 Max output power per port / 60W 50,8 Max output powermultiband per port/120W. 56.81Max output power per Radio 480W.
Antenna Gain (dBi)	According to SRSP-503(B5) & SRSP-518(B12A) calculation	
Antenna Impedance(Ω)	50	
Total RF bandwidth (IBW) B5	25MHz	25MHz
Total RF bandwidth (IBW) B12A	16MHz	16MHz
Supported Bandwidth(s) (MHz) B5	5,10MHz	5,10,15, 20,25MHz(SCS15kHz),10,15, 20, 25MHz(SCS30kHz)
Supported Bandwidth(s) (MHz) B5	ESS: 10MHz	
Supported Bandwidth(s) (MHz) B12A	5,10MHz	5,10,15MHz(SCS 15kHz),10,15MHz(SCS 30kHz)
Supported Bandwidth(s) (MHz) B12A	ESS :10MHz	
Modulation Scheme(s)	QPSK, 16QAM, 64QAM, 256QAM	QPSK, 16QAM, 64QAM, 256QAM
Supported NB-IoT: B5, B12A	NB-IoT(IB,GB), Modulation QPSK,	NB-IoT(IB) ,Modulation QPSK,
ITU Emission Designator	B5:	B12A:
	LTE with and without NB IoT IB: 5 MHz, BW: 4M48W7D LTE with NB IoT GB: 10 MHz,BW: 9M35W7D LTE carrier aggregation: 25MHz, BW: 24M3W7D (5 x 5MHz, CA)	LTE with and without NB IoT IB: 5 MHz, BW:4M49W7D LTE with NB IoT GB: 10 MHz,BW: 9M33W7D LTE carrier aggregation: 10MHz, BW: 9M45W7D (5MHz + 5MHz, CA)
	NR with NB IoT IB: 5 MHz, BW: 4M56W7D 10 MHz,BW:9M40W7D 15 MHz,BW:14M4W7D 20 MHz,BW:19M2W7D 25 MHz,BW:23M9W7D NR carrier aggregation: 25MHz, BW: 24M3W7D (5 x 5MHz, CA)	NR with NB IoT IB: 5 MHz, BW: 4M56W7D 10 MHz,BW:9M42W7D 15 MHz,BW:14M4W7D 20 MHz,BW:not support 25MHz,BW:not support NR carrier aggregation: 10MHz, BW: 9M43W7D (5MHz + 5MHz, CA)



Duplex mode:	FDD	FDD
Supported transmission modes:	4X4 MIMO	4X4 MIMO
Maximum number of carriers per band B5/Port	5	5
Maximum number of carriers per band 12A/Port	3	3
Maximum number of carriers per multi band (B5, 12A)/Port	8	8
Maximum NB-IoT GB carriers per host carrier	2	2
Maximum NB-IoT IB carriers per host carrier	1	1
Unintentional Radiators		
Highest frequency generated or used in the device or on which the device operates or tunes	Up to 25.8 Gbit/s	
Lowest frequency generated or used in the device or on which the device operates or tunes if <30MHz	.-	
Class A Digital Device (Use in commercial, industrial or business environment)	.-	
Class B Digital Device (Use in residential environment)	Class B	
DC Power Supply (Delete if Not Applicable)		
Nominal voltage:	-48V	
Extreme upper voltage:	-36V	
Extreme lower voltage:	-58.5V	
Max current:	36A	
Temperature		
Minimum temperature:	-40°C	
Maximum temperature:	55°C	
Ancillaries		
Manufacturer:	X	Part Number: X
Model:	X	Model: X
I hereby declare that I am entitled to sign on behalf of the manufacturer and that the information supplied is correct and complete.		
Name:	Afrah Ali sadiq	
Position held:	Regulatory Approval Engineer	
Email address:	Afrah.ali.sadiq@ericsson.com	
Telephone number:	.+46724650796	
Date:	03/04/2023	

No responsibility will be accepted by TÜV SÜD as to the accuracy of the information declared in this document by the manufacturer.

1.6 PRODUCT INFORMATION

1.6.1 Technical Description

The Equipment Under Test (EUT) Radio 4490HP 44B5 44B12A C - KRC 161 981/3 is an Ericsson AB Radio Unit working in the public mobile service Band 5 band which provides communication connections to Band 5 network.

The EUT is declared as operating from a nominal -48V DC supply.

The Equipment Under Test (EUT) is shown in the photograph below. A full technical description can be found in the Manufacturer's documentation.



Equipment Under Test

1.7 TEST SETUP

Conducted Test Set Up

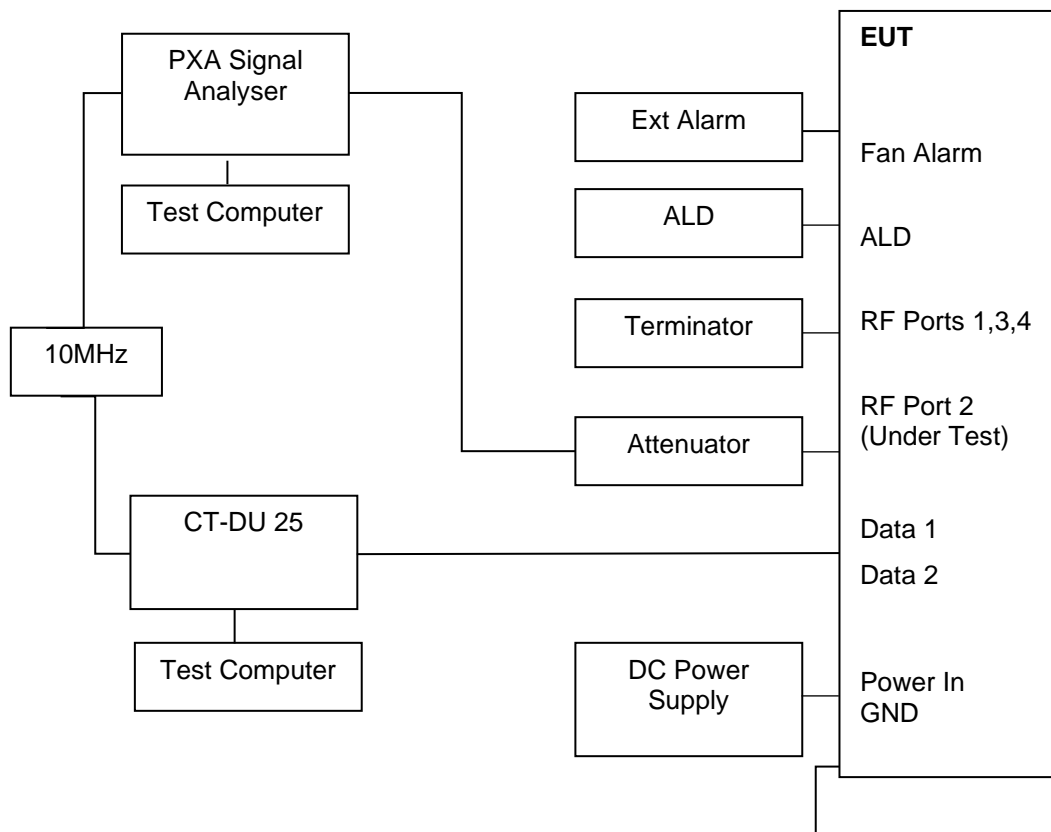



Test Conditions

For all tests the EUT was set up in accordance with the relevant test standard and to represent typical operating conditions. Tests were applied with the EUT situated as described in the Test Method for each Test.

The EUT was powered from a -54V DC supply unless otherwise stated.

563983 Ericsson Test Laboratory, Kista
Postal Address: Ericsson AB, Isafjordsgatan 10, Stockholm, SE-16 440, Sweden
CA4810 TUV SUD Ottawa, Canada

ISED Accreditation

IC#26170 Ericsson Test Laboratory, Kista
Postal Address: Ericsson AB, Isafjordsgatan 10, Stockholm, SE-164 40, Sweden

Under our group Swedac Accreditation, TÜV SÜD Sverige conducted the following tests
Ericsson Test Lab, Kista.

Test Name	Name of Engineer(s)
Occupied Bandwidth	Ashok Kumar
Band Edge	Ashok Kumar
Transmitter Spurious Emissions	Ashok Kumar
Frequency Stability	Ashok Kumar

1.8 DEVIATION FROM THE STANDARD

No deviations from the applicable test standards or test plan were made during testing.

1.9 MODIFICATION RECORD

No modifications were made to the EUT during testing.



1.10 ADDITIONAL INFORMATION

The Test Plan is based on the TÜV SÜD Document FCC and ISED Test Plan Rationale for Base Station Equipment.

Pre-testing was performed in accordance with the Test Plan to establish the worst-case Port, modulation schemes and bandwidths.

The port with the highest power, worst case port was port 2

Worst case modulation was QPSK (LTE), QPSK (NR)

Worst case bandwidth was 5 MHz for LTE, 25 MHz for NR SCS 15kHz and 25 MHz for NR SCS 30 kHz.

For 2 Carrier Multi RAT tests the following combinations were chosen as the worst case supported NR 15 MHz SCS 30kHz + LTE 5 MHz SCS 15kHz.

For 3 Carrier Multi RAT tests the following combinations were chosen as the worst case supported NR 15 MHz SCS 30kHz + LTE 5 MHz SCS 15kHz+ LTE 5 MHz SCS 15kHz.

Transmitter performance was measured for top, mid & bottom channels across all 4 antenna ports as presented in the average power measurement tables.

This EUT uses the same port for Tx and Rx and therefore RX Spurious Emissions has not been performed. Rx Spurious Emissions have been covered by testing to FCC Part 15B, which are covered by a separate test report.

Ericsson have provided the following details about the variant of the Radio 4490HP 44B5 44B12A C, KRC 161 981/3*

KRC 161 981/31** – (with security software for testing purpose.

Note*: Tests have been performed on this unit.

Note**: This will be the marketed, sold unit.

Therefore, KRC 161 981/31 is equivalent to KRC 161 981/3 in conducted radio performance terms, as such no extra testing is required to prove conformity.

Throughout this report the power unit dBm is used. dBm is a unit of level used to indicate that a power level is expressed in decibels (dB) with reference to one milliwatt (mW). It is used as a convenient measure of absolute power because of its capability to express both very large and very small values in a short form.



SECTION 2

TEST DETAILS



2.1 MAXIMUM PEAK OUTPUT POWER AND PEAK TO AVERAGE RATIO - CONDUCTED

2.1.1 Specification Reference

FCC CFR 47 Part 22, Clause 22.913 (a)
ISED RSS-132, Clause 5.4
FCC CFR 47 Part 2, Clause 2.1046

2.1.2 Date of Test and Modification State

08, 09, 10, 13, 15, 20, 21, 24 March-2023 - Modification State 0

2.1.3 Test Equipment Used

The major items of test equipment used for the above tests are identified in Section 3.1.

2.1.4 Environmental Conditions

Ambient Temperature	22.0 - 22.8°C
Relative Humidity	37.8 - 39.8%

2.1.5 Test Method

All measurements were made in accordance with FCC KDB 971168 D01, clause 5.2.1 and summed in accordance with FCC KDB 662911 D01.

The plot results presented are the measured worst case and represent typical performance for all bands and antenna ports, plot data performance is on file and available on request.

Calculations

Total power = Measured Output Power (port A, worst case) + 10log (NANT)
Where NANT refers to the number of Ports.

Total Power = Measured Output Power (port 2, worst case) + 10log (4)

Remarks

* Maximum antenna system gain (including cable loss), GANT (dBi) 50 ohm, for the tested configurations, to comply with Maximum radiated output power in ISED SRSP-503

2.1.6 Test Results



Configuration 1

Maximum Output Power 47.80 dBm

Antenna	LTE Modulation	LTE Carrier Bandwidth	Peak to Average Ratio (PAR) / Output Power / PSD										
			Channel Position B										
			PAR (dB)	Average Power/PSD		Total Power Port 1+2+3+4		Urban E.I.R.P Limit 820W/5MHz		Non Urban E.I.R.P Limit 1640W/5MHz		GANT* Urban	GANT* Non Urban
	dBm	dBm/MHz	dBm	dBm/MHz	dBm	dBm/MHz	dBm	dBm/MHz	dBm	dBm/MHz	dBi	dBi	
2	QPSK	5.0 MHz	7.25	47.38	41.07	53.40	47.09	59.14	-	62.15	-	5.74	8.75
2	QPSK	10.0 MHz	7.33	47.50	38.30	53.52	44.32	-	52.15	-	55.16	7.83	10.84

Antenna 2 - LTE Modulation QPSK - LTE Carrier Bandwidth 5.0 MHz - Channel Position B

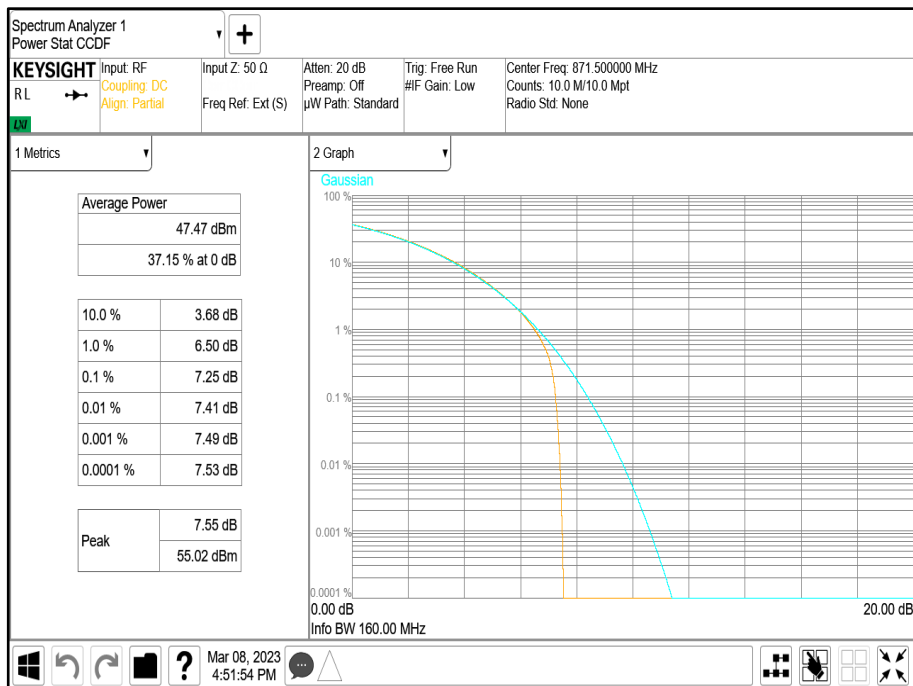



Antenna 2 - LTE Modulation QPSK - LTE Carrier Bandwidth 10.0 MHz - Channel Position B

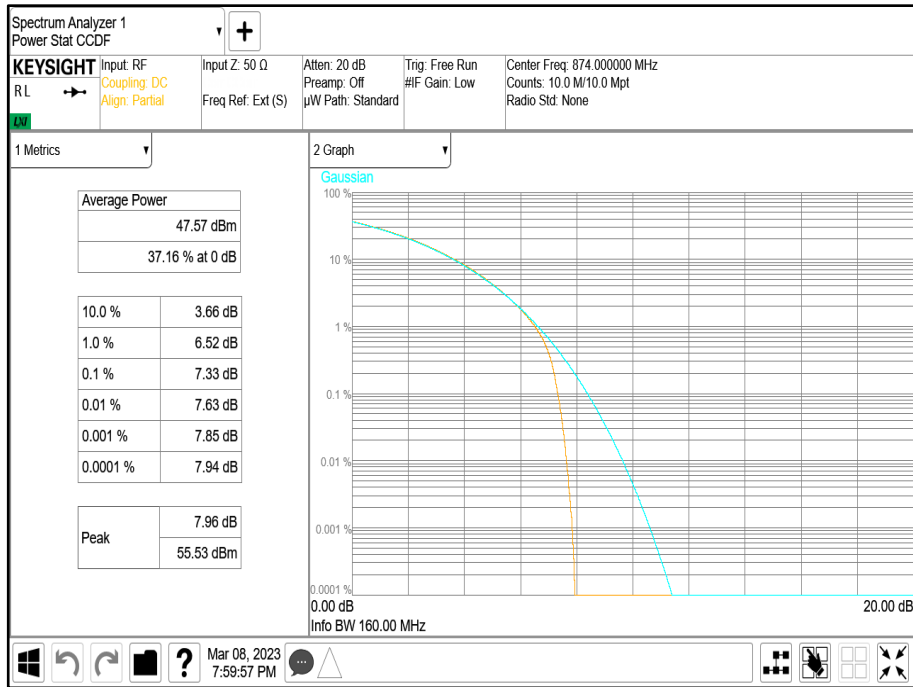



Configuration 1

Maximum Output Power 47.80 dBm

Antenna	LTE Modulation	LTE Carrier Bandwidth	Peak to Average Ratio (PAR) / Output Power / PSD										
			Channel Position M										
			PAR (dB)	Average Power/PSD		Total Power Port 1+2+3+4		Urban E.I.R.P Limit 820W/5MHz		Non Urban E.I.R.P Limit 1640W/5MHz		GANT* Urban	GANT* Non Urban
dBm	dBm/MHz	dBm		dBm/MHz	dBm	dBm/MHz	dBm	dBm/MHz	dBm	dBm/MHz	dBi	dBi	
2	QPSK	5.0 MHz	7.24	47.29	40.89	53.31	46.91	59.14	-	62.15	-	5.83	8.84
2	QPSK	10.0 MHz	7.23	47.35	37.99	53.37	44.01	-	52.15	-	55.16	8.14	11.15

Antenna 2 - LTE Modulation QPSK - LTE Carrier Bandwidth 5.0 MHz - Channel Position M

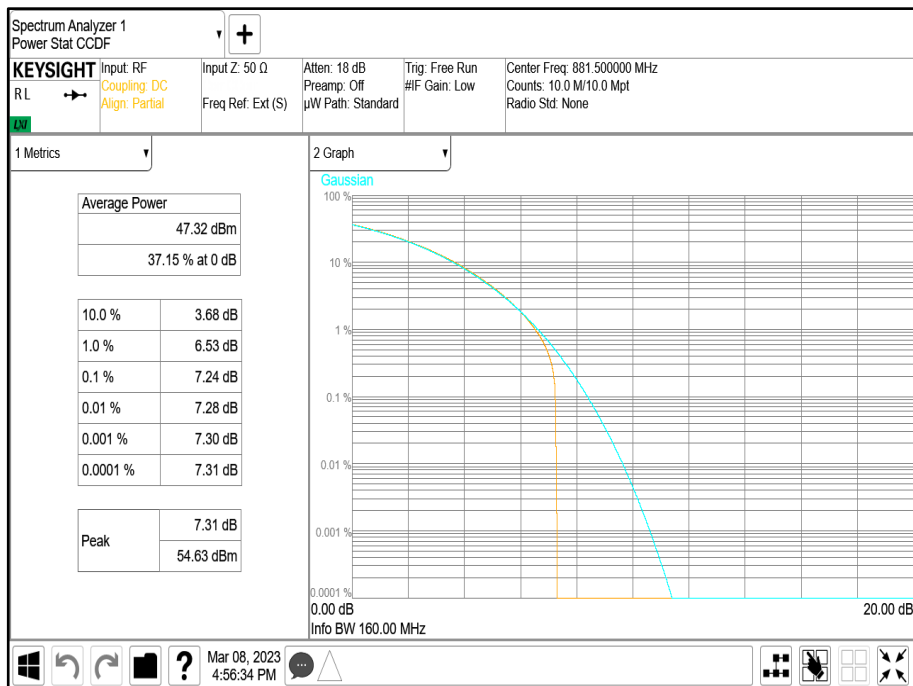



Antenna 2 - LTE Modulation QPSK - LTE Carrier Bandwidth 10.0 MHz - Channel Position M

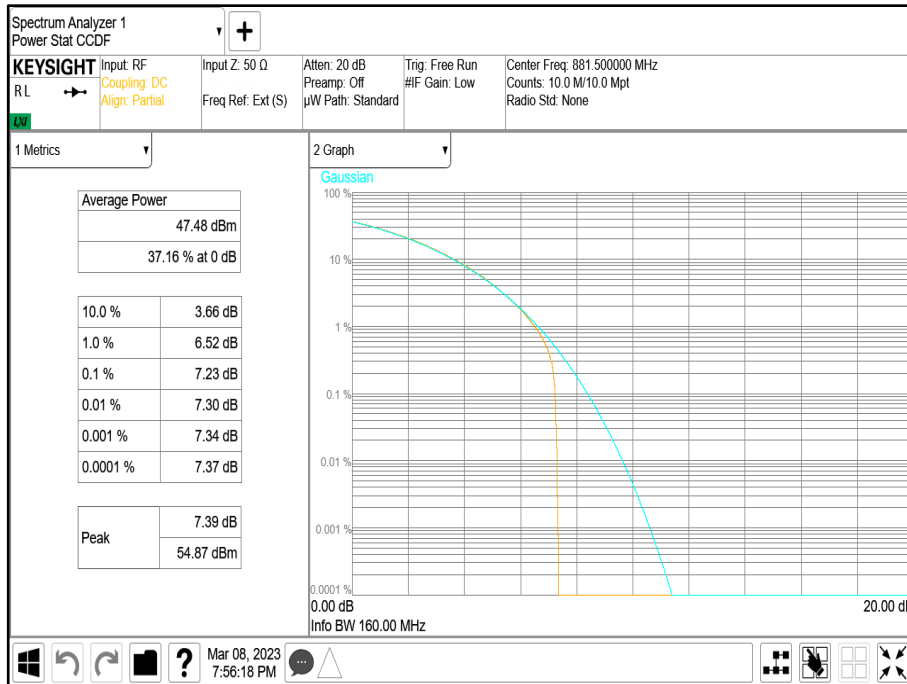

Configuration 1

Maximum Output Power 47.80 dBm

Antenna	LTE Modulation	LTE Carrier Bandwidth	Peak to Average Ratio (PAR) / Output Power / PSD										
			Channel Position T										
			PAR (dB)	Average Power/PSD		Total Power Port 1+2+3+4		Urban E.I.R.P Limit 820W/5MHz		Non Urban E.I.R.P Limit 1640W/5MHz		GANT* Urban	GANT* Non Urban
	dBm	dBm/MHz	dBm	dBm/MHz	dBm	dBm/MHz	dBm	dBm/MHz	dBm	dBm/MHz	dBi	dBi	
2	QPSK	5.0 MHz	7.25	47.21	41.43	53.23	47.45	59.14	-	62.15	-	5.91	8.92
2	QPSK	10.0 MHz	7.31	47.44	38.96	53.46	44.98	-	52.15	-	55.16	7.17	10.18



Antenna 2 - LTE Modulation QPSK - LTE Carrier Bandwidth 5.0 MHz - Channel Position T

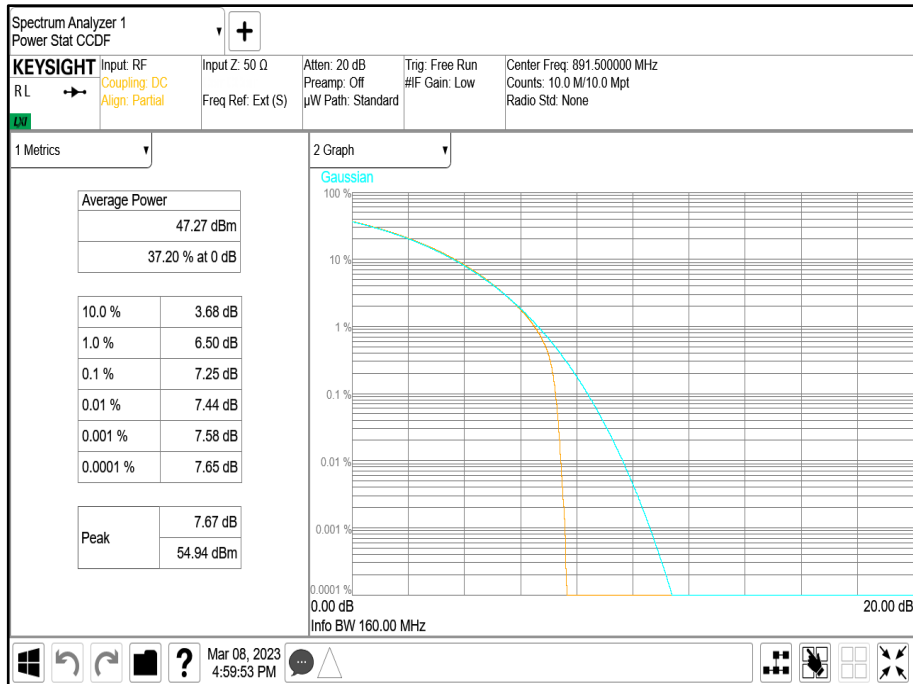

Antenna 2 - LTE Modulation QPSK - LTE Carrier Bandwidth 10.0 MHz - Channel Position T

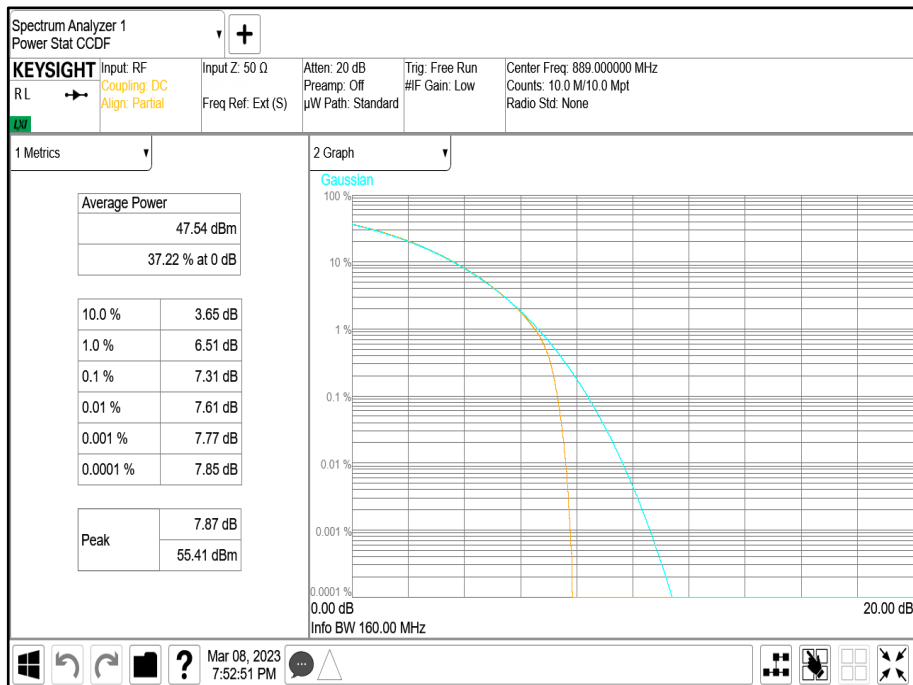



Configuration 2

Maximum Output Power 47.80 dBm

Antenna	LTE Modulation	LTE Carrier Bandwidth	Peak to Average Ratio (PAR) / Output Power / PSD				
			Channel Position M				
			PAR (dB)	Average Power/PSD		Total Power Port 1+2+3+4	
				dBm	dBm/MHz	dBm	dBm/MHz
2	QPSK	5.0 MHz	-	47.22	37.72	53.24	43.74
2	QPSK	10.0 MHz	-	47.17	34.81	53.19	40.83

Configuration 3

Maximum Output Power 47.80 dBm

Antenna	LTE Modulation	LTE Carrier Bandwidth	Peak to Average Ratio (PAR) / Output Power / PSD				
			Channel Position M				
			PAR (dB)	Average Power/PSD		Total Power Port 1+2+3+4	
				dBm	dBm/MHz	dBm	dBm/MHz
2	QPSK	5.0 MHz	-	47.16	33.82	53.18	39.84

Configuration 4

Maximum Output Power 47.80 dBm

Antenna	NR Modulation	NR Carrier Bandwidth	Peak to Average Ratio (PAR) / Output Power / PSD										
			Channel Position B										
			PAR (dB)	Average Power/PSD		Total Power Port 1+2+3+4		Urban E.I.R.P Limit 820W/5MHz		Non Urban E.I.R.P Limit 1640W/5MHz		GANT* Urban	GANT* Non Urban
				dBm	dBm/MHz	dBm	dBm/MHz	dBm	dBm/MHz	dBm	dBm/MHz	dBi	dBi
2	QPSK	5.0 MHz 15 kHz SCS	7.28	47.66	42.50	53.68	48.52	59.14	-	62.15	-	5.46	8.47
2	QPSK	10.0 MHz 30 kHz SCS	7.31	47.44	38.41	53.46	44.43	-	52.15	-	55.16	7.72	10.73
2	QPSK	15.0 MHz 30 kHz SCS	7.42	47.42	36.32	53.44	42.34	-	53.15	-	56.16	10.81	13.82
2	QPSK	20.0 MHz 30 kHz SCS	7.41	47.50	35.13	53.52	41.15	-	54.15	-	57.16	13.00	16.01
2	QPSK	25.0 MHz 30 kHz SCS	7.41	47.26	33.81	53.28	39.83	-	55.15	-	58.16	15.32	18.33



Antenna 2 - NR Modulation QPSK - NR Carrier Bandwidth 5.0 MHz 15 kHz SCS - Channel Position B

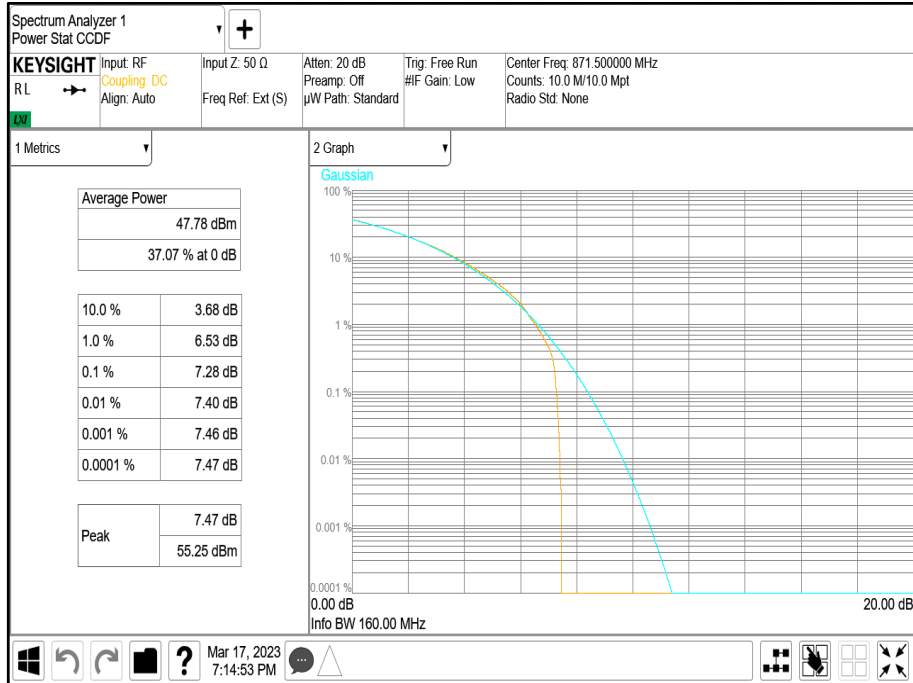

Antenna 2 - NR Modulation QPSK - NR Carrier Bandwidth 10.0 MHz 30 kHz SCS - Channel Position B

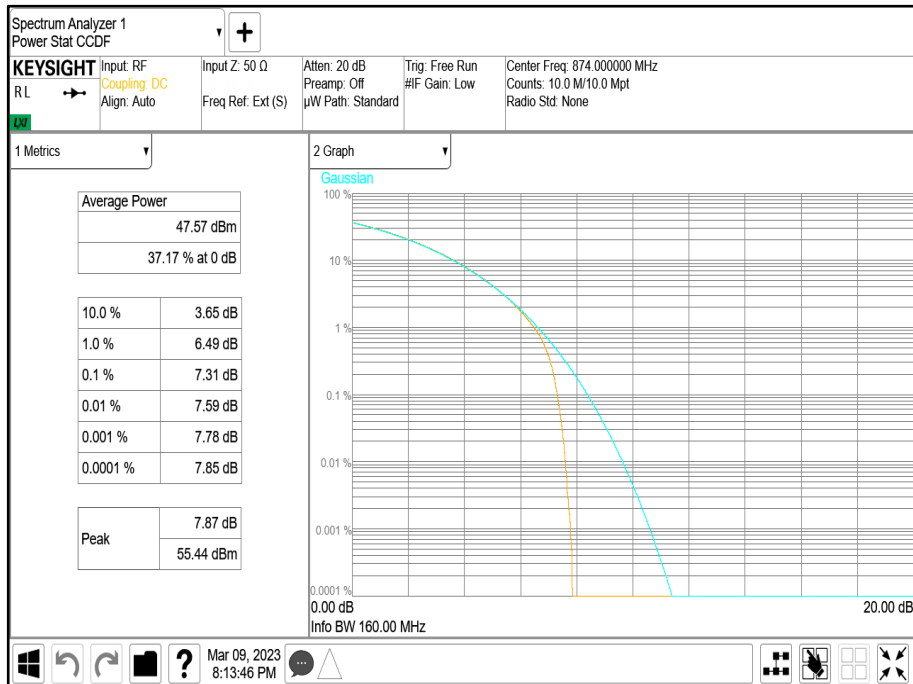



Antenna 2 - NR Modulation QPSK - NR Carrier Bandwidth 15.0 MHz 30 kHz SCS - Channel Position B

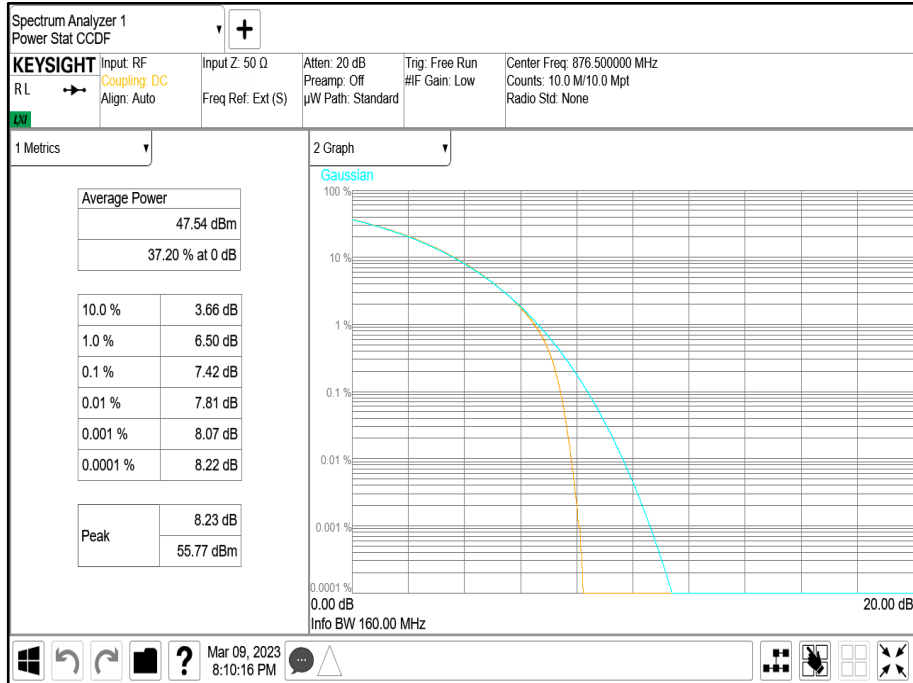

Antenna 2 - NR Modulation QPSK - NR Carrier Bandwidth 20.0 MHz 30 kHz SCS - Channel Position B

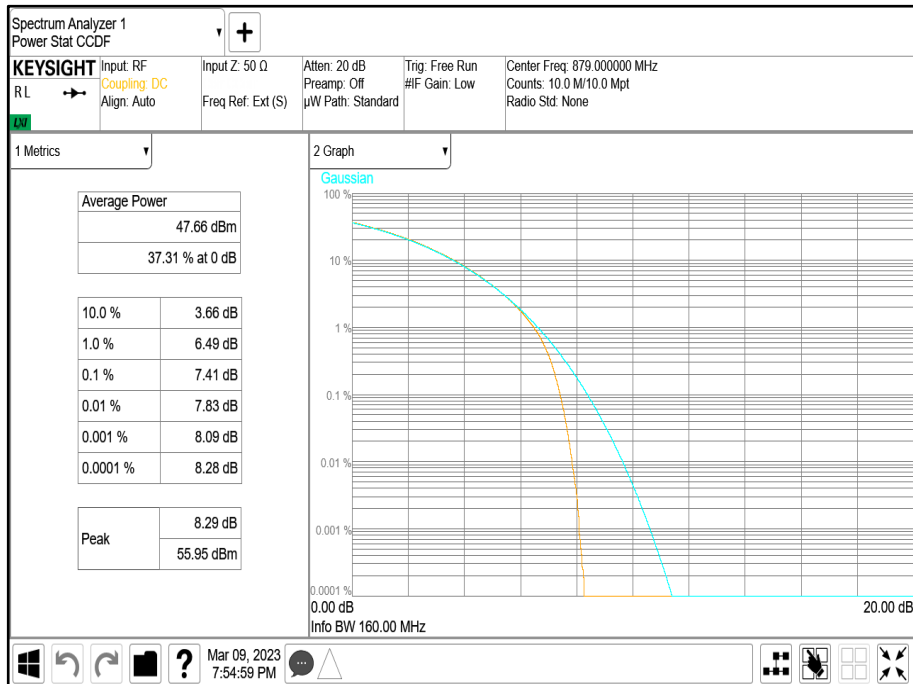



Antenna 2 - NR Modulation QPSK - NR Carrier Bandwidth 25.0 MHz 30 kHz SCS - Channel Position B

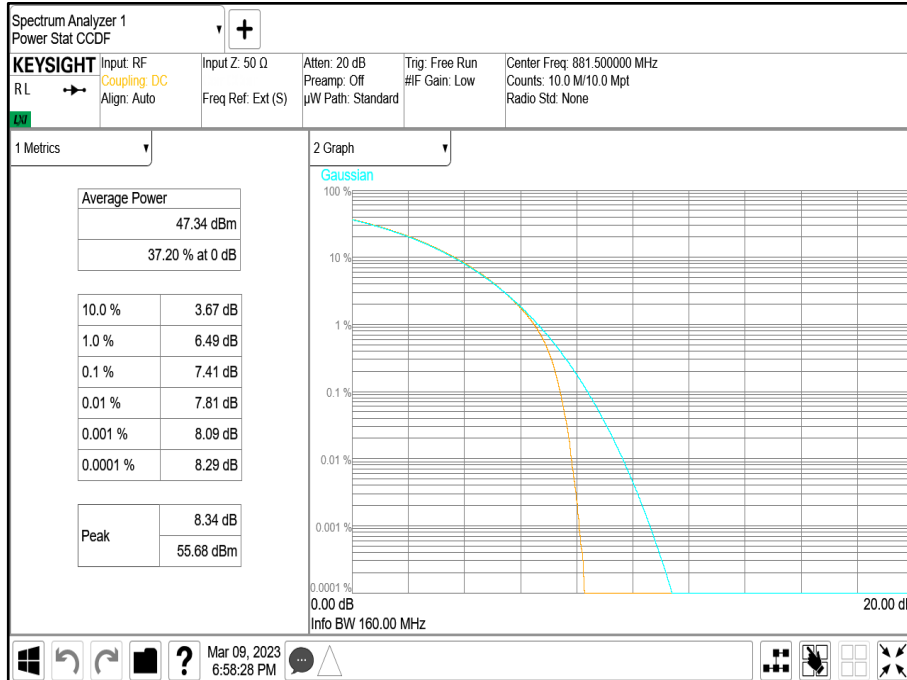

Configuration 4

Maximum Output Power 47.80 dBm

Antenna	NR Modulation	NR Carrier Bandwidth	Peak to Average Ratio (PAR) / Output Power / PSD										
			Channel Position M										
			PAR (dB)	Average Power/PSD		Total Power Port 1+2+3+4		Urban E.I.R.P Limit 820W/5MHz		Non Urban E.I.R.P Limit 1640W/5MHz		GANT* Urban	GANT* Non Urban
				dBm	dBm/MHz	dBm	dBm/MHz	dBm	dBm/MHz	dBm	dBm/MHz	dBi	dBi
2	QPSK	5.0 MHz 15 kHz SCS	7.23	47.45	42.32	53.47	48.34	59.14	-	62.15	-	5.67	8.68
2	QPSK	10.0 MHz 30 kHz SCS	7.23	47.36	38.17	53.38	44.19	-	52.15	-	55.16	7.96	10.97
2	QPSK	15.0 MHz 30 kHz SCS	7.28	47.28	36.18	53.30	42.20	-	53.15	-	56.16	10.95	13.96
2	QPSK	20.0 MHz 30 kHz SCS	7.27	47.31	34.99	53.33	41.01	-	54.15	-	57.16	13.14	16.15
2	QPSK	25.0 MHz 30 kHz SCS	-	-	-	-	-	-	-	-	-	-	-

Remarks

The IBW of this band is 25 MHz and therefore only one channel was performed at 25MHz bandwidth



Antenna 2 - NR Modulation QPSK - NR Carrier Bandwidth 5.0 MHz 15 kHz SCS - Channel Position M

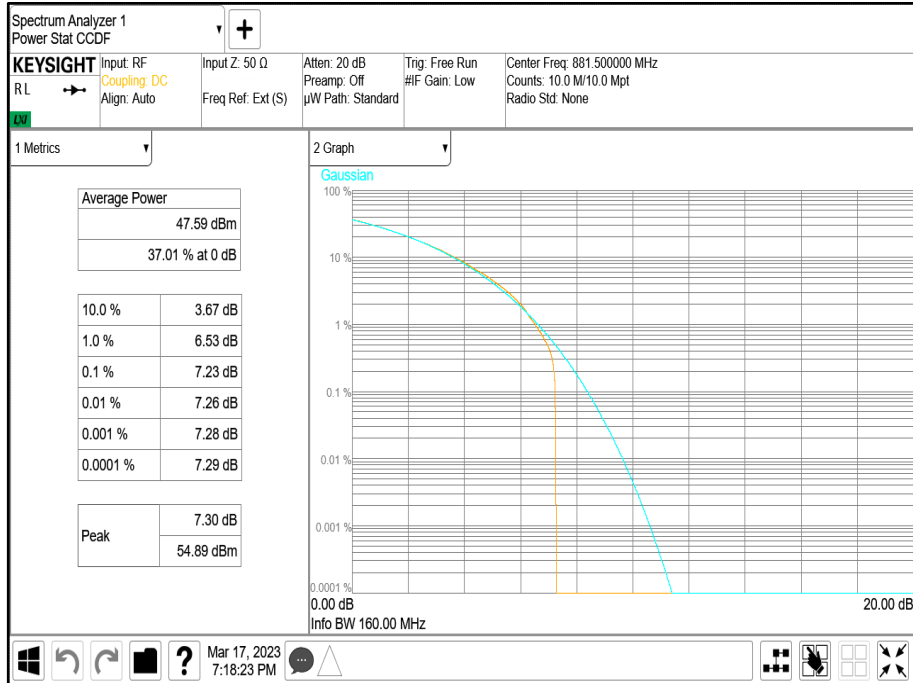

Antenna 2 - NR Modulation QPSK - NR Carrier Bandwidth 10.0 MHz 30 kHz SCS - Channel Position M

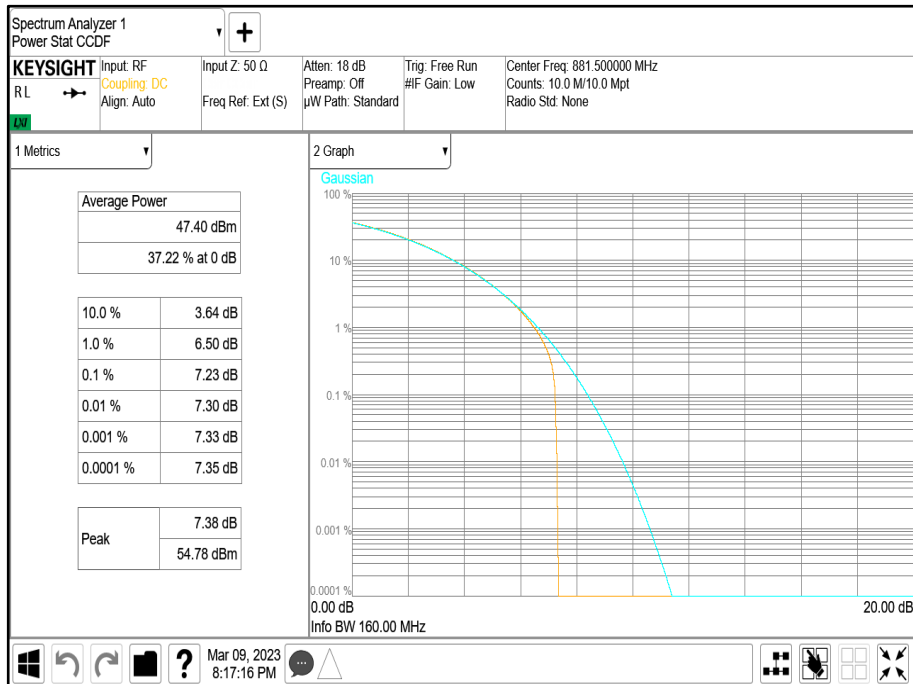



Antenna 2 - NR Modulation QPSK - NR Carrier Bandwidth 15.0 MHz 30 kHz SCS - Channel Position M

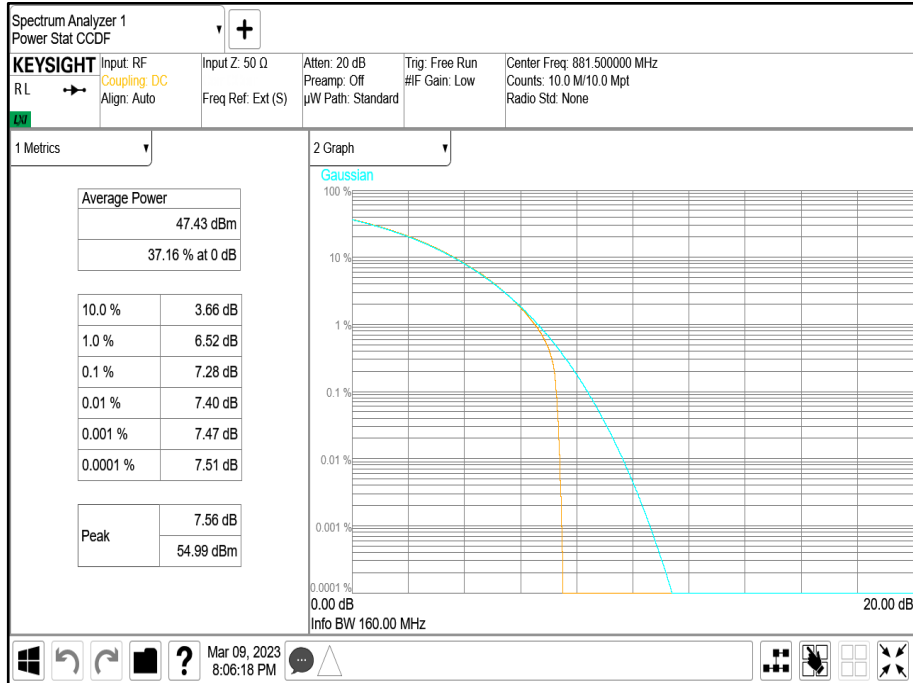

Antenna 2 - NR Modulation QPSK - NR Carrier Bandwidth 20.0 MHz 30 kHz SCS - Channel Position M

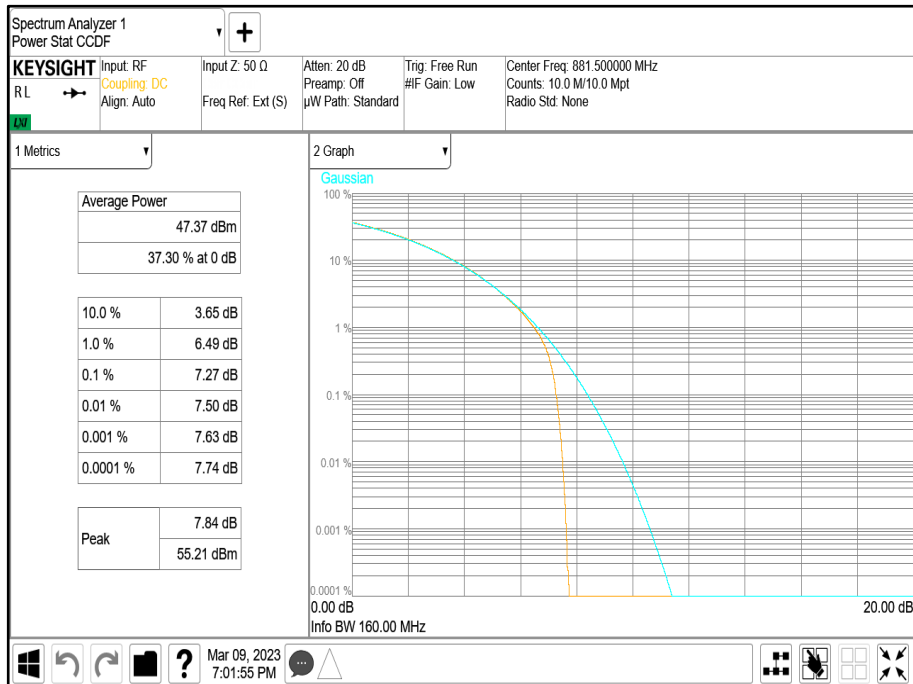



Configuration 4

Maximum Output Power 47.80 dBm

Antenna	NR Modulation	NR Carrier Bandwidth	Peak to Average Ratio (PAR) / Output Power / PSD										
			Channel Position T										
			PAR (dB)	Average Power/PSD		Total Power Port 1+2+3+4		Urban E.I.R.P Limit 820W/5MHz		Non Urban E.I.R.P Limit 1640W/5MHz		GANT* Urban	GANT* Non Urban
dBm	dBm/MHz	dBm		dBm/MHz	dBm	dBm/MHz	dBm	dBm/MHz	dBm	dBm/MHz	dBi	dBi	
2	QPSK	5.0 MHz 15 kHz SCS	7.21	47.32	42.26	53.34	48.28	59.14	-	62.15	-	5.80	8.81
2	QPSK	10.0 MHz 30 kHz SCS	7.30	47.32	38.11	53.34	44.13	-	52.15	-	55.16	8.02	11.03
2	QPSK	15.0 MHz 30 kHz SCS	7.37	47.41	36.26	53.43	42.28	-	53.15	-	56.16	10.87	13.88
2	QPSK	20.0 MHz 30 kHz SCS	7.31	47.45	35.03	53.47	41.05	-	54.15	-	57.16	13.10	16.11
2	QPSK	25.0 MHz 30 kHz SCS	-	-	-	-	-	-	-	-	-	-	-

Remarks

The IBW of this band is 25 MHz and therefore only one channel was performed at 25MHz bandwidth

Antenna 2 - NR Modulation QPSK - NR Carrier Bandwidth 5.0 MHz 15 kHz SCS - Channel Position T

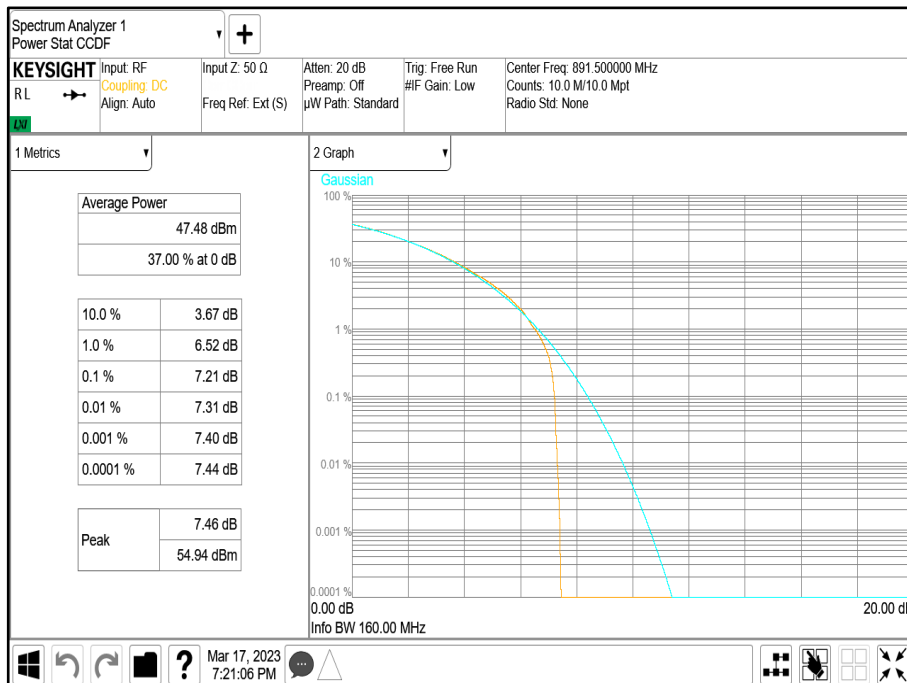



Antenna 2 - NR Modulation QPSK - NR Carrier Bandwidth 10.0 MHz 30 kHz SCS - Channel Position T

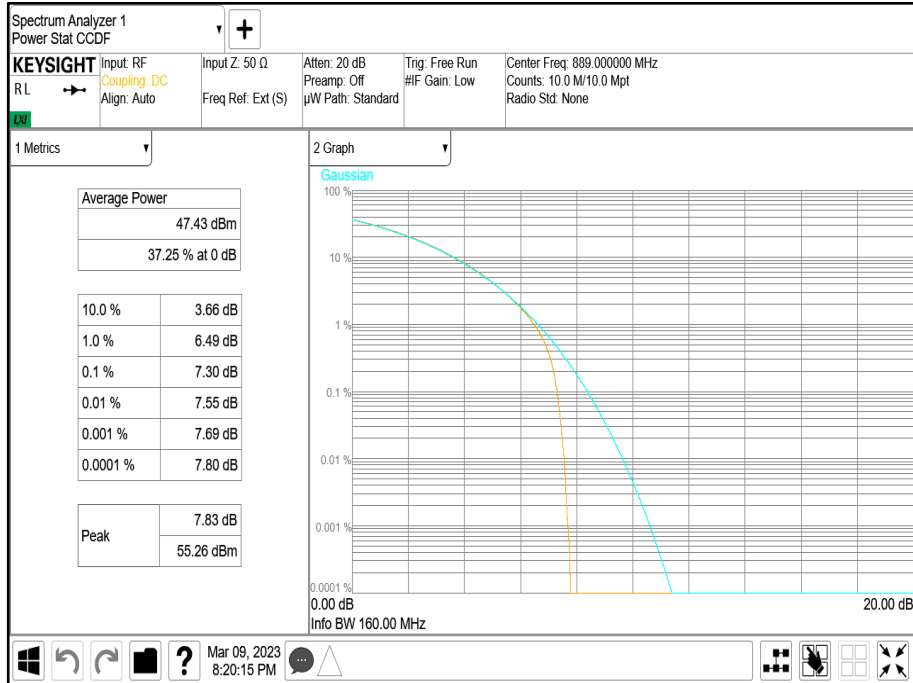

Antenna 2 - NR Modulation QPSK - NR Carrier Bandwidth 15.0 MHz 30 kHz SCS - Channel Position T

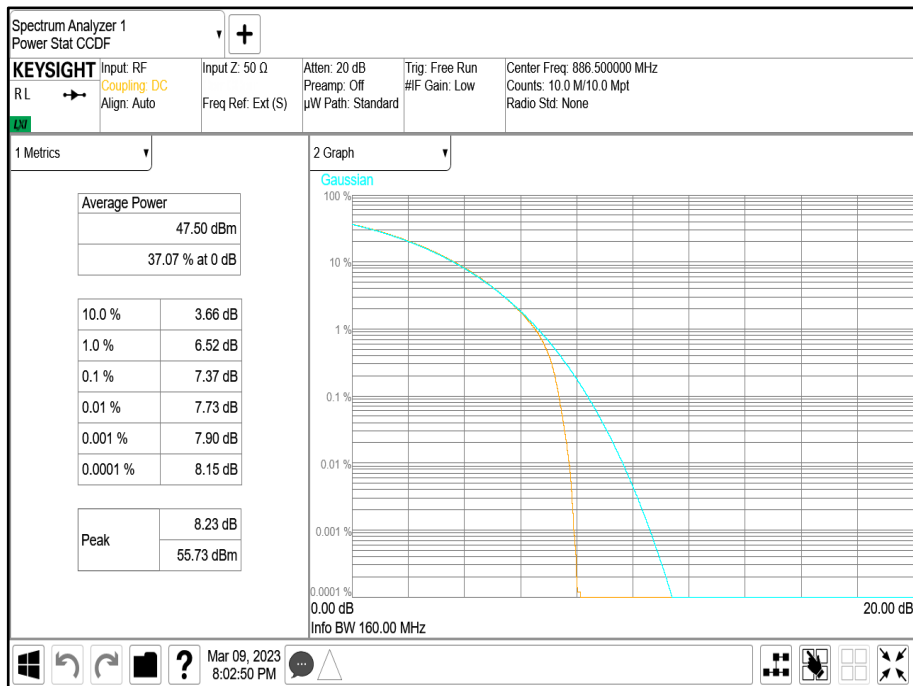



Antenna 2 - NR Modulation QPSK - NR Carrier Bandwidth 20.0 MHz 30 kHz SCS - Channel Position T

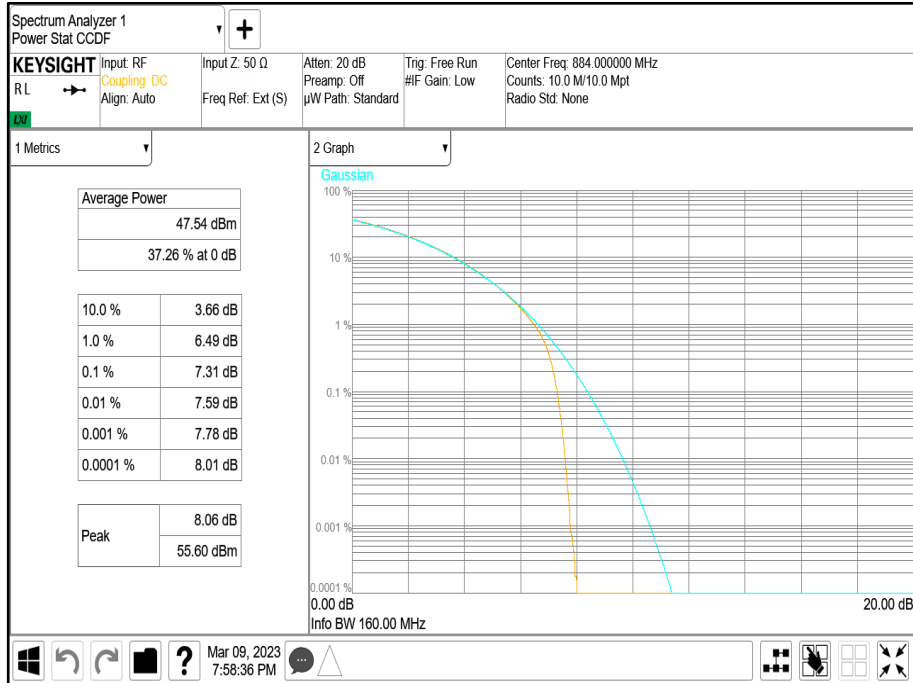

Configuration 5

Maximum Output Power 47.80 dBm

Antenna	NR Modulation	NR Carrier Bandwidth	Peak to Average Ratio (PAR) / Output Power / PSD				
			Channel Position M				
			PAR (dB)	Average Power/PSD		Total Power Port 1+2+3+4	
			dBm	dBm/MHz	dBm	dBm/MHz	
2	QPSK	5.0 MHz 15 kHz SCS	-	47.28	38.40	53.30	44.42
2	QPSK	10.0 MHz 30 kHz SCS	-	47.14	34.97	53.16	40.99

Configuration 6

Maximum Output Power 47.80 dBm

Antenna	NR Modulation	NR Carrier Bandwidth	Peak to Average Ratio (PAR) / Output Power / PSD				
			Channel Position M				
			PAR (dB)	Average Power/PSD		Total Power Port 1+2+3+4	
			dBm	dBm/MHz	dBm	dBm/MHz	
2	QPSK	5.0 MHz 15 kHz SCS	-	47.30	34.50	53.32	40.52



Configuration 7

Maximum Output Power 47.80 dBm

Antenna	LTE / NR Modulation	LTE / NR Carrier Bandwidth	Peak to Average Ratio (PAR) / Output Power / PSD				
			Channel Position M				
			PAR (dB)	Average Power/PSD		Total Power Port 1+2+3+4	
				dBm	dBm/MHz	dBm	dBm/MHz
2	QPSK / QPSK	15.0 MHz / 5.0 MHz	-	47.16	37.66	53.18	43.68

Configuration 8

Maximum Output Power 47.80 dBm

Antenna	LTE / NR Modulation	LTE / NR Carrier Bandwidth	Peak to Average Ratio (PAR) / Output Power / PSD				
			Channel Position M				
			PAR (dB)	Average Power/PSD		Total Power Port 1+2+3+4	
				dBm	dBm/MHz	dBm	dBm/MHz
A	QPSK / QPSK	15.0 MHz / 5.0 MHz	-	47.24	36.09	53.26	42.11

Configuration 9

Maximum Output Power 47.80 dBm

Antenna	NR NB-IoT IB Modulation	NR NB-IoT IB Carrier Bandwidth	Peak to Average Ratio (PAR) / Output Power / PSD										
			Channel Position B										
			PAR (dB)	Average Power/PSD		Total Power Port 1+2+3+4		Urban E.I.R.P Limit 820W/5MHz		Non Urban E.I.R.P Limit 1640W/5MHz		GANT* Urban	GANT* Non Urban
				dBm	dBm/MHz	dBm	dBm/MHz	dBm	dBm/MHz	dBm	dBm/MHz	dBm	dBm/MHz
2	QPSK	5.00 MHz	7.35	47.39	41.92	53.41	47.94	59.14	-	62.15	-	5.73	8.74
2	QPSK	10.00 MHz	7.42	47.59	39.37	53.61	45.39	-	52.15	-	55.16	6.76	9.77
2	QPSK	15.00 MHz	7.45	47.51	38.80	53.53	44.82	-	53.15	-	56.16	8.33	11.34
2	QPSK	20.00 MHz	7.57	47.15	38.05	53.17	44.07	-	54.15	-	57.16	10.08	13.09
2	QPSK	25.00 MHz	7.47	47.31	34.59	53.33	40.61	-	55.15	-	58.16	14.54	17.55



Antenna 2 - NR NB-IoT IB Modulation QPSK - NR NB-IoT IB Carrier Bandwidth 5.00 MHz - Channel Position B

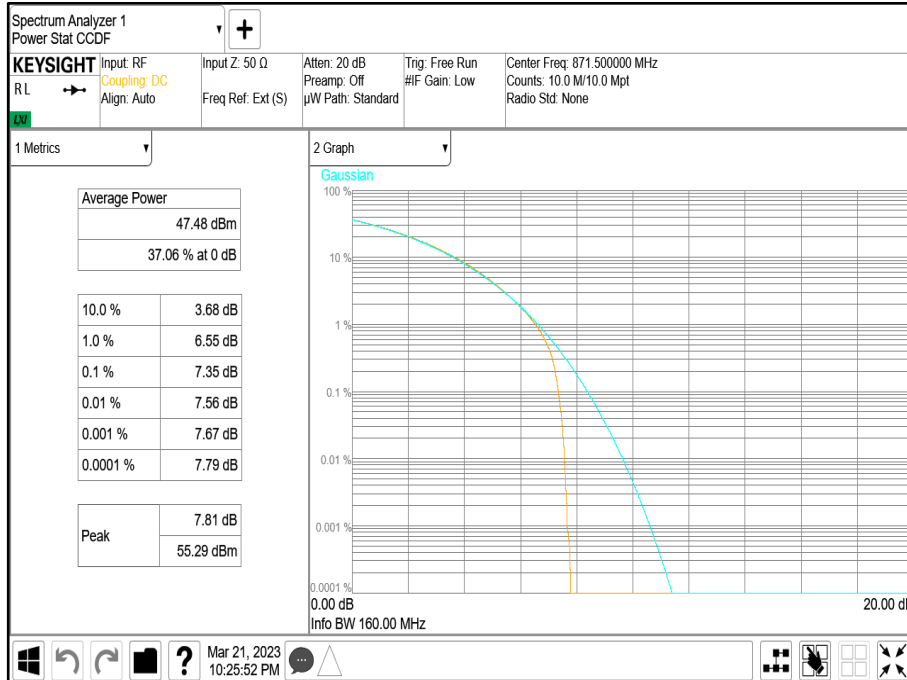

Antenna 2 - NR NB-IoT IB Modulation QPSK - NR NB-IoT IB Carrier Bandwidth 10.00 MHz - Channel Position B

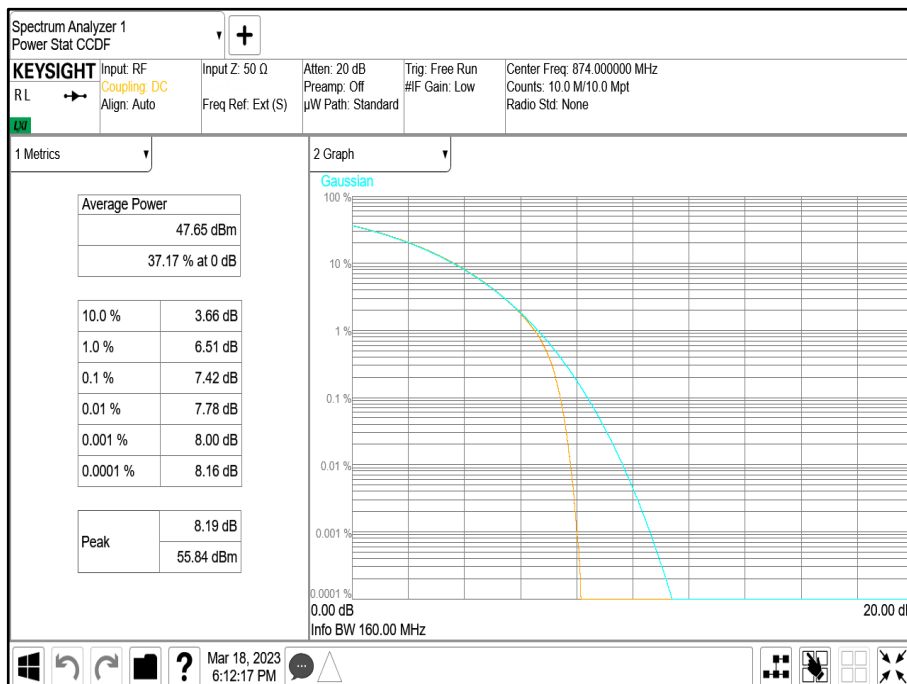



Antenna 2 - NR NB-IoT IB Modulation QPSK - NR NB-IoT IB Carrier Bandwidth 15.00 MHz - Channel Position B

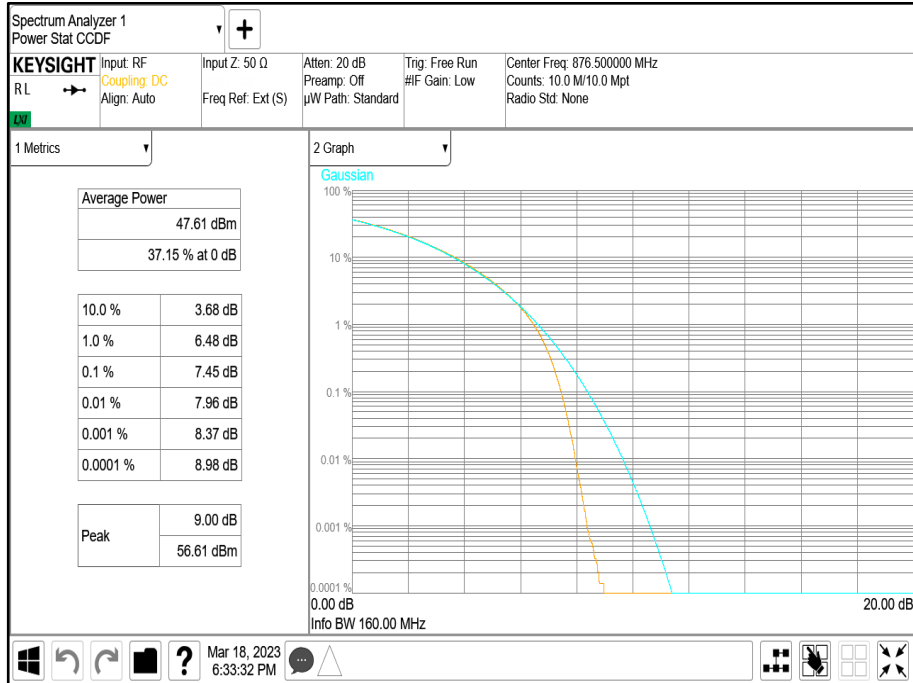

Antenna 2 - NR NB-IoT IB Modulation QPSK - NR NB-IoT IB Carrier Bandwidth 20.00 MHz - Channel Position B

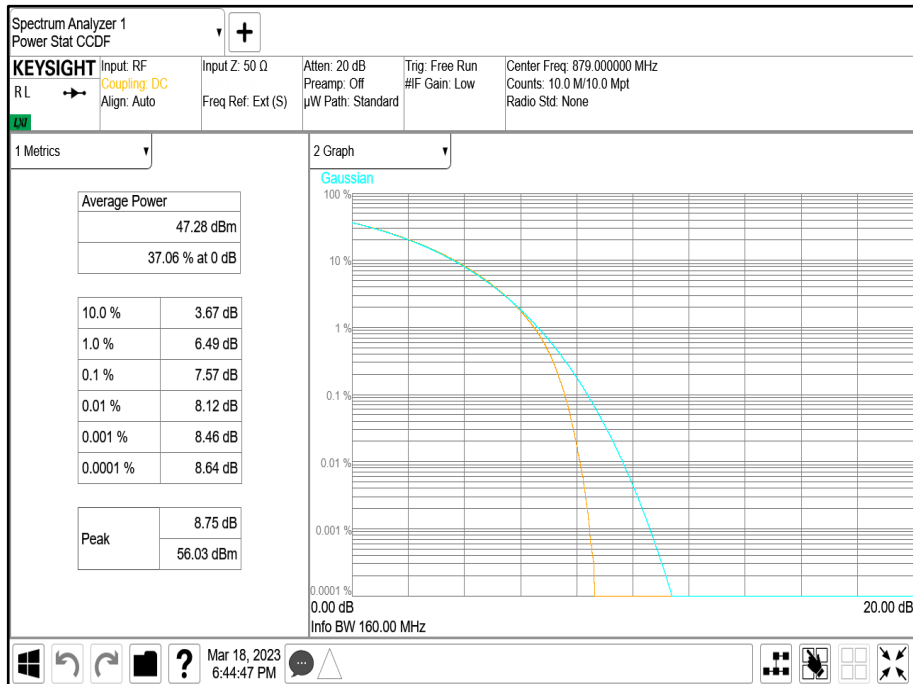



Antenna 2 - NR NB-IoT IB Modulation QPSK - NR NB-IoT IB Carrier Bandwidth 25.00 MHz - Channel Position B

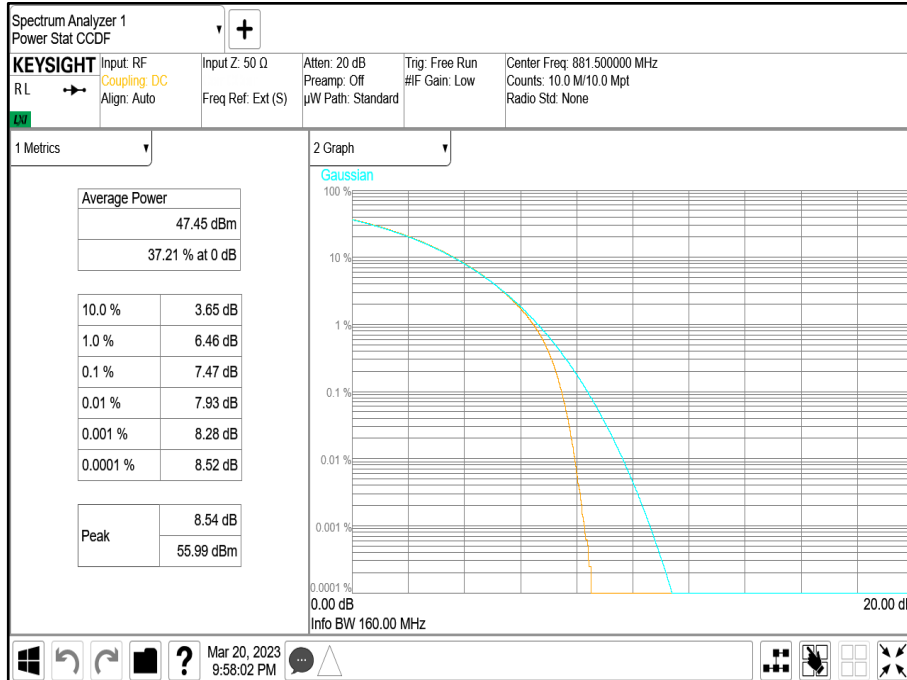

Configuration 9

Maximum Output Power 47.80 dBm

Antenna	NR NB-IoT IB Modulation	NR NB-IoT IB Carrier Bandwidth	Peak to Average Ratio (PAR) / Output Power / PSD										
			Channel Position M										
			PAR (dB)	Average Power/PSD		Total Power Port 1+2+3+4		Urban E.I.R.P Limit 820W/5MHz		Non Urban E.I.R.P Limit 1640W/5MHz		GANT* Urban	GANT* Non Urban
				dBm	dBm/MHz	dBm	dBm/MHz	dBm	dBm/MHz	dBm	dBm/MHz	dBi	dBi
2	QPSK	5.00 MHz	7.37	47.23	41.79	53.25	47.81	59.14	-	62.15	-	5.89	8.90
2	QPSK	10.00 MHz	7.29	47.30	38.88	53.32	44.90	-	52.15	-	55.16	7.25	10.26
2	QPSK	15.00 MHz	7.19	47.40	38.43	53.42	44.45	-	53.15	-	56.16	8.70	11.71
2	QPSK	20.00 MHz	7.38	47.06	37.83	53.08	43.85	-	54.15	-	57.16	10.30	13.31
2	QPSK	25.00 MHz	7.47	47.36	34.57	53.38	40.59	-	55.15	-	58.16	14.56	17.57



Antenna 2 - NR NB-IoT IB Modulation QPSK - NR NB-IoT IB Carrier Bandwidth 5.00 MHz - Channel Position M

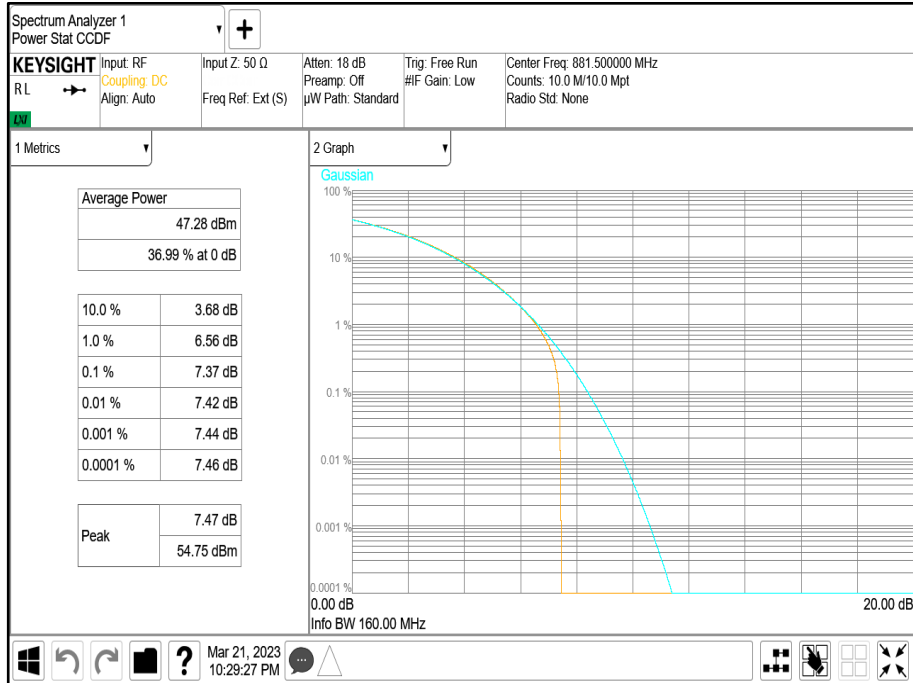

Antenna 2 - NR NB-IoT IB Modulation QPSK - NR NB-IoT IB Carrier Bandwidth 10.00 MHz - Channel Position M

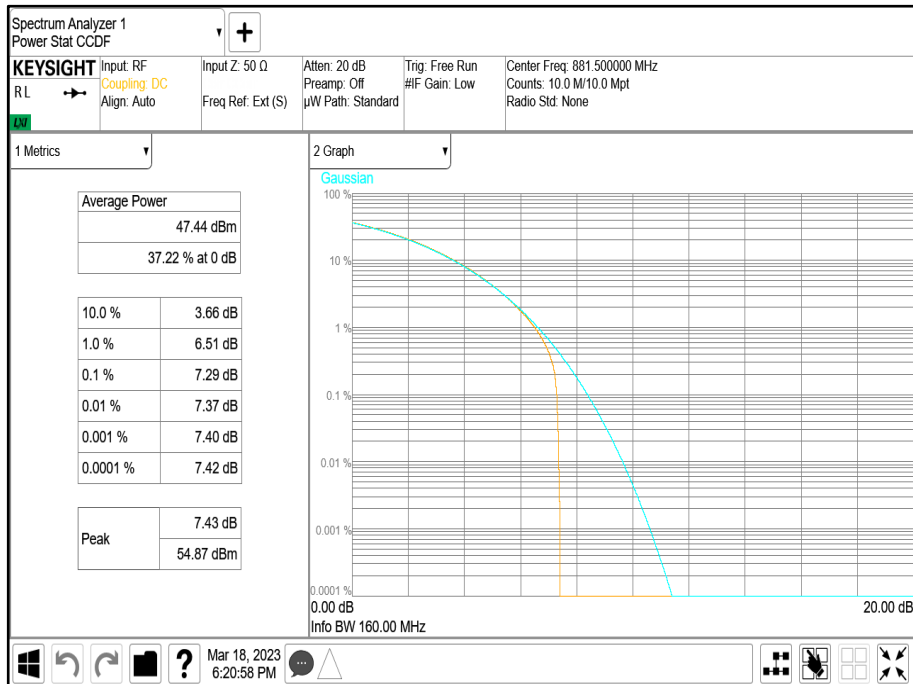



Antenna 2 - NR NB-IoT IB Modulation QPSK - NR NB-IoT IB Carrier Bandwidth 15.00 MHz - Channel Position M

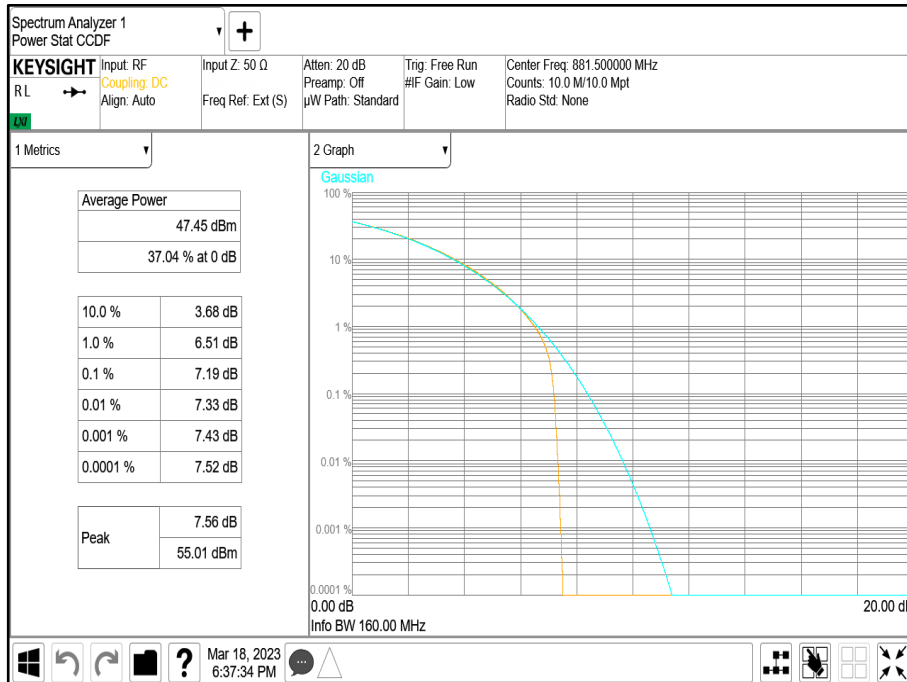

Antenna 2 - NR NB-IoT IB Modulation QPSK - NR NB-IoT IB Carrier Bandwidth 20.00 MHz - Channel Position M

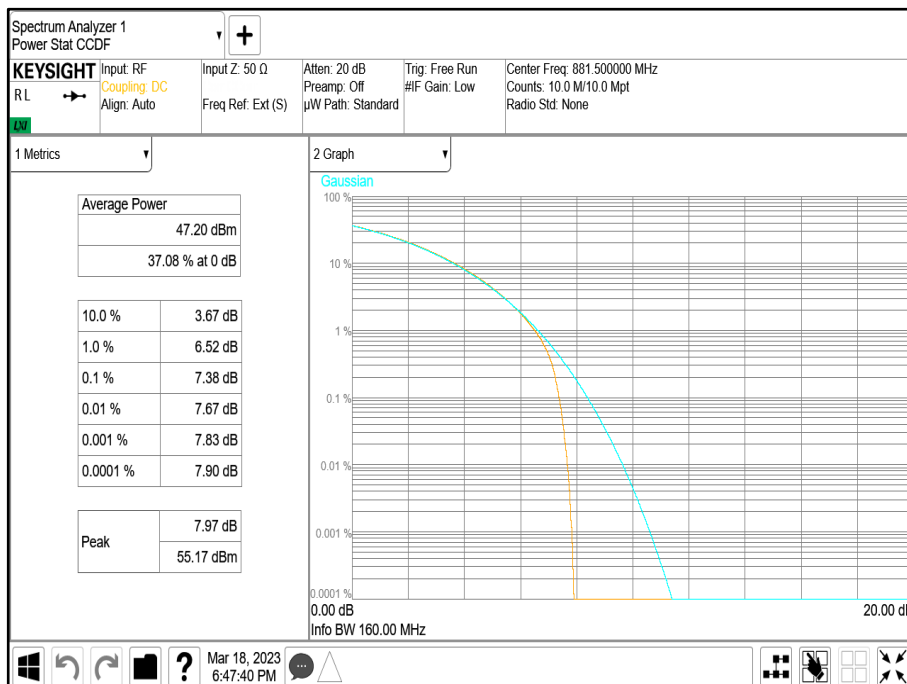



Antenna 2 - NR NB-IoT IB Modulation QPSK - NR NB-IoT IB Carrier Bandwidth 25.00 MHz - Channel Position M

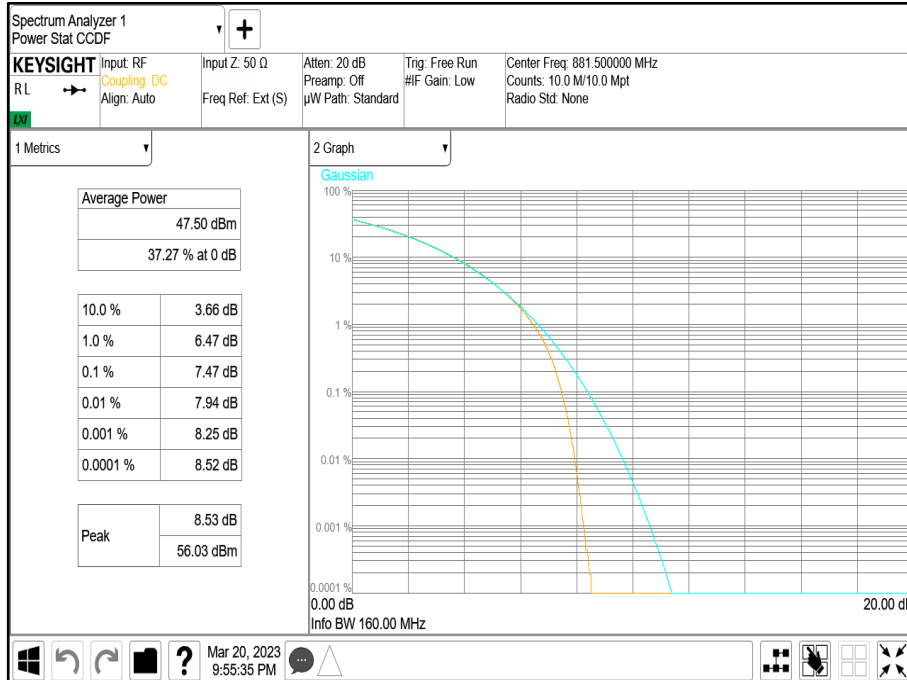

Configuration 9

Maximum Output Power 47.80 dBm

Antenna	NR NB-IoT IB Modulation	NR NB-IoT IB Carrier Bandwidth	Peak to Average Ratio (PAR) / Output Power / PSD										
			Channel Position T										
			PAR (dB)	Average Power/PSD		Total Power Port 1+2+3+4		Urban E.I.R.P Limit 820W/5MHz		Non Urban E.I.R.P Limit 1640W/5MHz		GANT* Urban	GANT* Non Urban
				dBm	dBm/MHz	dBm	dBm/MHz	dBm	dBm/MHz	dBm	dBm/MHz	dBi	dBi
2	QPSK	5.00 MHz	7.38	47.13	41.92	53.15	47.94	59.14	-	62.15	-	5.99	9.00
2	QPSK	10.00 MHz	7.41	47.30	38.97	53.32	44.99	-	52.15	-	55.16	7.16	10.17
2	QPSK	15.00 MHz	7.35	47.34	38.53	53.36	44.55	-	53.15	-	56.16	8.60	11.61
2	QPSK	20.00 MHz	7.45	47.03	37.91	53.05	43.93	-	54.15	-	57.16	10.22	13.23
2	QPSK	25.00 MHz	7.47	47.46	34.58	53.48	40.60	-	55.15	-	58.16	14.55	17.56



Antenna 2 - NR NB-IoT IB Modulation QPSK - NR NB-IoT IB Carrier Bandwidth 5.00 MHz - Channel Position T

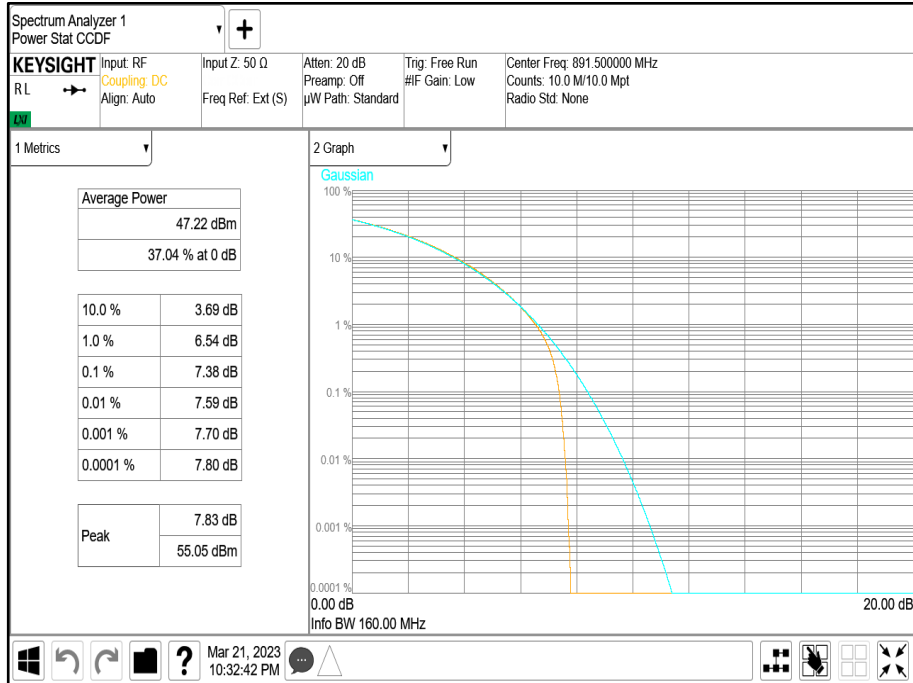

Antenna 2 - NR NB-IoT IB Modulation QPSK - NR NB-IoT IB Carrier Bandwidth 10.00 MHz - Channel Position T

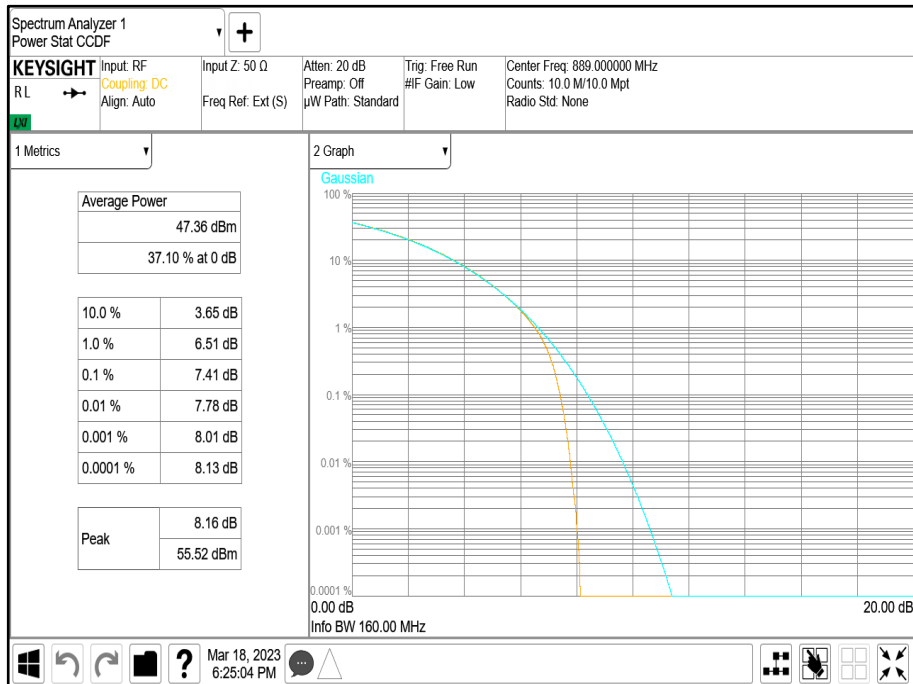



Antenna 2 - NR NB-IoT IB Modulation QPSK - NR NB-IoT IB Carrier Bandwidth 15.00 MHz - Channel Position T

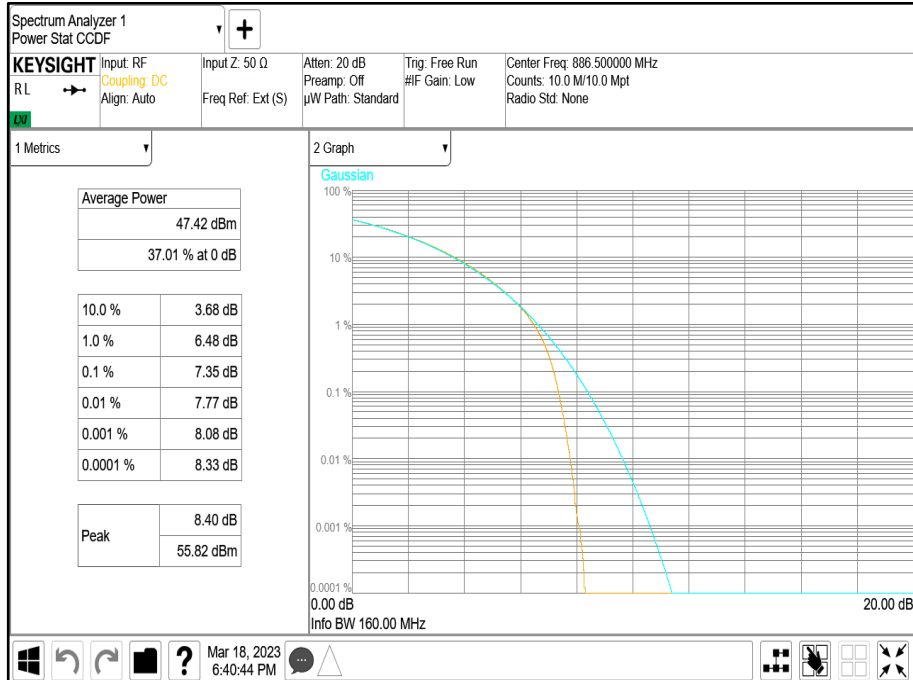

Antenna 2 - NR NB-IoT IB Modulation QPSK - NR NB-IoT IB Carrier Bandwidth 20.00 MHz - Channel Position T

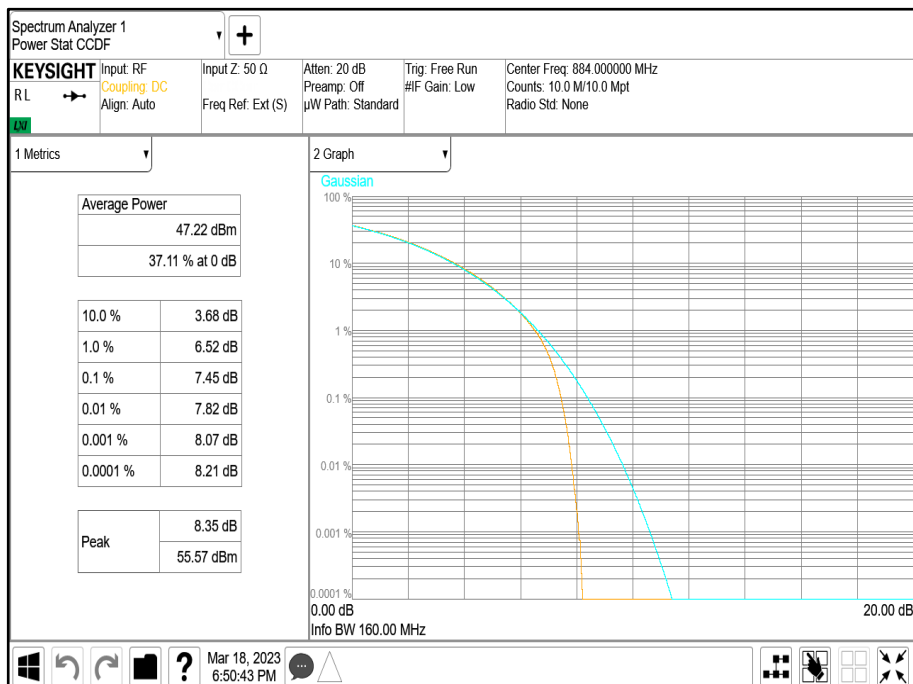



Antenna 2 - NR NB-IoT IB Modulation QPSK - NR NB-IoT IB Carrier Bandwidth 25.00 MHz - Channel Position T

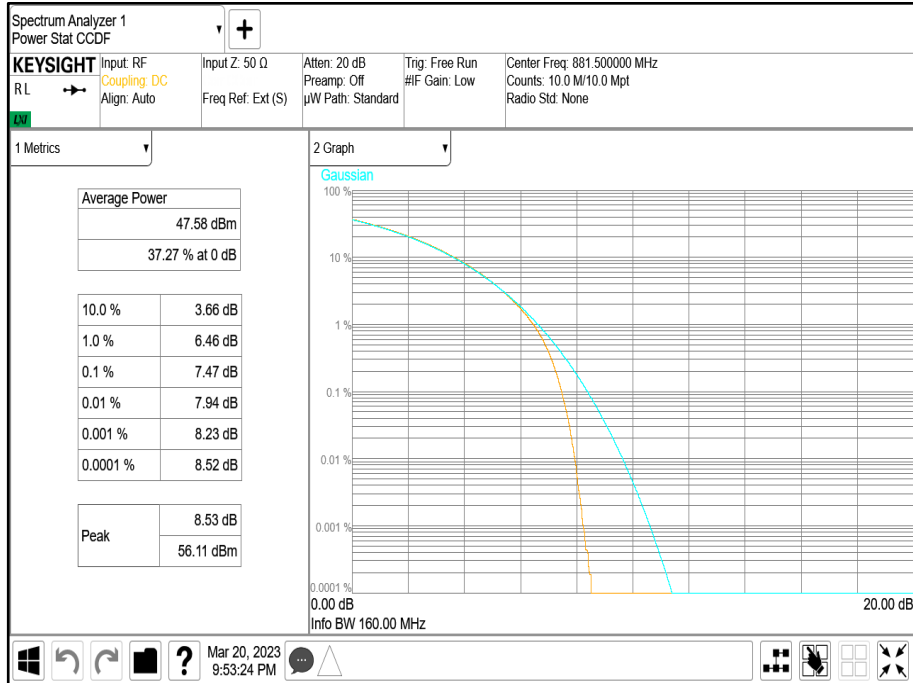

Configuration 10

Maximum Output Power 47.80 dBm

Antenna	LTE / NB-IoT IB Modulation	LTE / NB-IoT IB Carrier Bandwidth	Peak to Average Ratio (PAR) / Output Power / PSD										
			Channel Position B										
			PAR (dB)	Average Power/PSD		Total Power Port 1+2+3+4		Urban E.I.R.P Limit 820W/5MHz		Non Urban E.I.R.P Limit 1640W/5MHz		GANT* Urban	GANT* Non Urban
				dBm	dBm/MHz	dBm	dBm/MHz	dBm	dBm/MHz	dBm	dBm/MHz	dBm	dBm
2	QPSK	5.00 MHz	7.65	47.13	41.79	53.15	47.81	59.14	-	62.15	-	5.99	9.00



Antenna 2 - LTE / NB-IoT IB Modulation QPSK - LTE / NB-IoT IB Carrier Bandwidth 5.00 MHz - Channel Position B

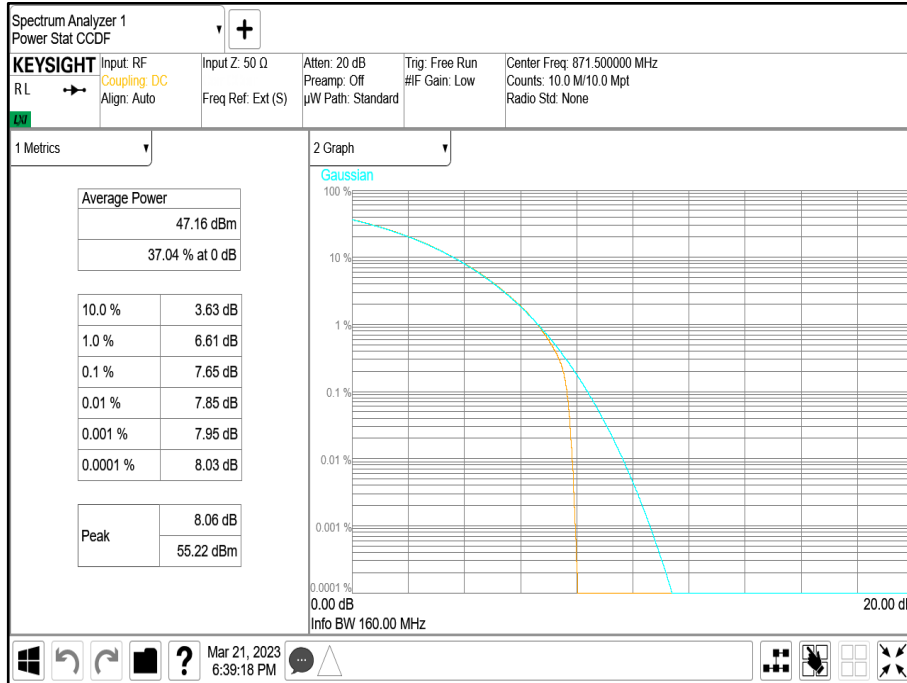

Configuration 10

Maximum Output Power 47.80 dBm

Antenna	LTE / NB-IoT IB Modulation	LTE / NB-IoT IB Carrier Bandwidth	Peak to Average Ratio (PAR) / Output Power / PSD										
			Channel Position M										
			PAR (dB)	Average Power/PSD		Total Power Port 1+2+3+4		Urban E.I.R.P Limit 820W/5MHz		Non Urban E.I.R.P Limit 1640W/5MHz		GANT* Urban	GANT* Non Urban
				dBm	dBm/MHz	dBm	dBm/MHz	dBm	dBm/MHz	dBm	dBm/MHz	dBi	dBi
2	QPSK	5.00 MHz	7.68	47.01	41.83	53.03	47.85	59.14	-	62.15	-	6.11	9.12



Antenna 2 - LTE / NB-IoT IB Modulation QPSK - LTE / NB-IoT IB Carrier Bandwidth 5.00 MHz - Channel Position M

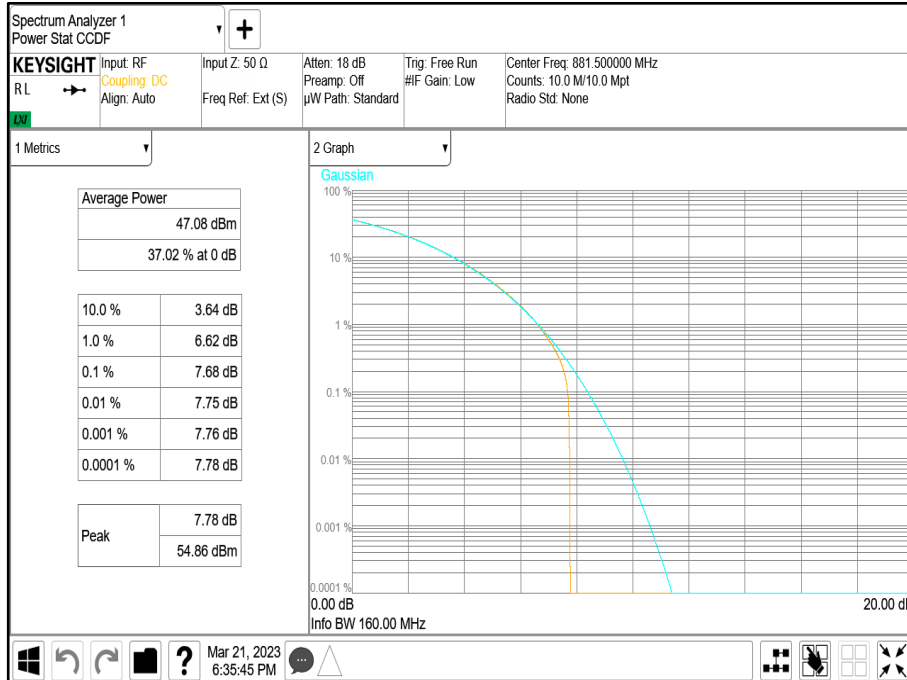

Configuration 10

Maximum Output Power 47.80 dBm

Antenna	LTE / NB-IoT IB Modulation	LTE / NB-IoT IB Carrier Bandwidth	Peak to Average Ratio (PAR) / Output Power / PSD										
			Channel Position T										
			PAR (dB)	Average Power/PSD		Total Power Port 1+2+3+4		Urban E.I.R.P Limit 820W/5MHz		Non Urban E.I.R.P Limit 1640W/5MHz		GANT* Urban	GANT* Non Urban
				dBm	dBm/MHz	dBm	dBm/MHz	dBm	dBm/MHz	dBm	dBm/MHz	dBi	dBi
2	QPSK	5.00 MHz	7.65	46.94	41.92	52.96	47.94	59.14	-	62.15	-	6.18	9.19



Antenna 2 - LTE / NB-IoT IB Modulation QPSK - LTE / NB-IoT IB Carrier Bandwidth 5.00 MHz - Channel Position T

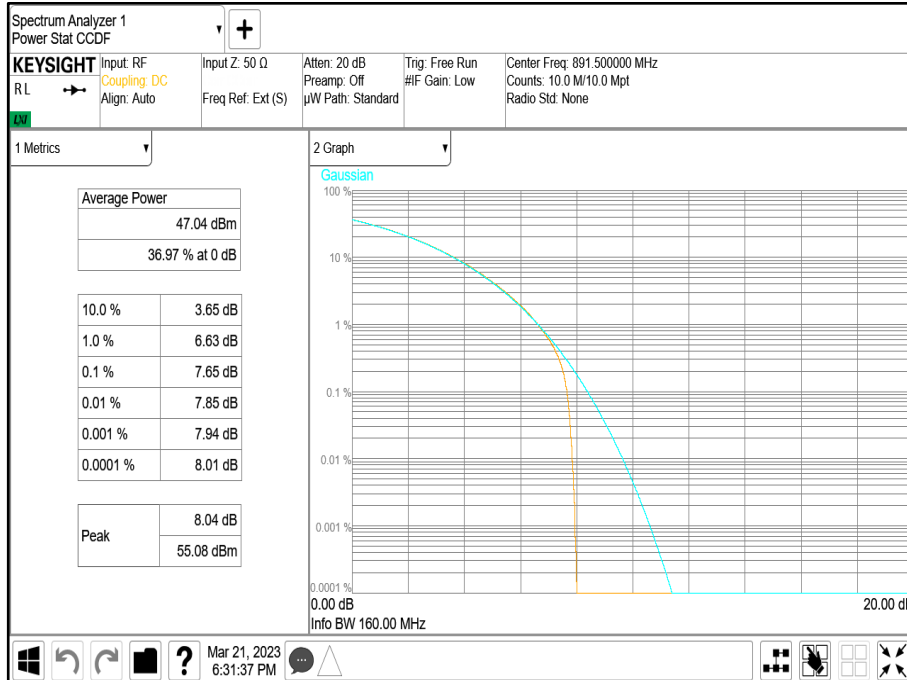

Configuration 11

Maximum Output Power 47.80 dBm

Antenna	LTE / NB-IOT GB Modulation	LTE / NB-IOT GB Carrier Bandwidth	Peak to Average Ratio (PAR) / Output Power / PSD										
			Channel Position B										
			PAR (dB)	Average Power/PSD		Total Power Port 1+2+3+4		Urban E.I.R.P Limit 820W/5MHz		Non Urban E.I.R.P Limit 1640W/5MHz		GANT* Urban	GANT* Non Urban
				dBm	dBm/MHz	dBm	dBm/MHz	dBm	dBm/MHz	dBm	dBm/MHz	dBi	dBi
2	QPSK	10.00 MHz	7.70	47.04	38.47	53.06	44.49	59.14	-	62.15	-	6.08	9.09



Antenna 2 - LTE / NB-IOT GB Modulation QPSK - LTE / NB-IOT GB Carrier Bandwidth 10.00 MHz - Channel Position B

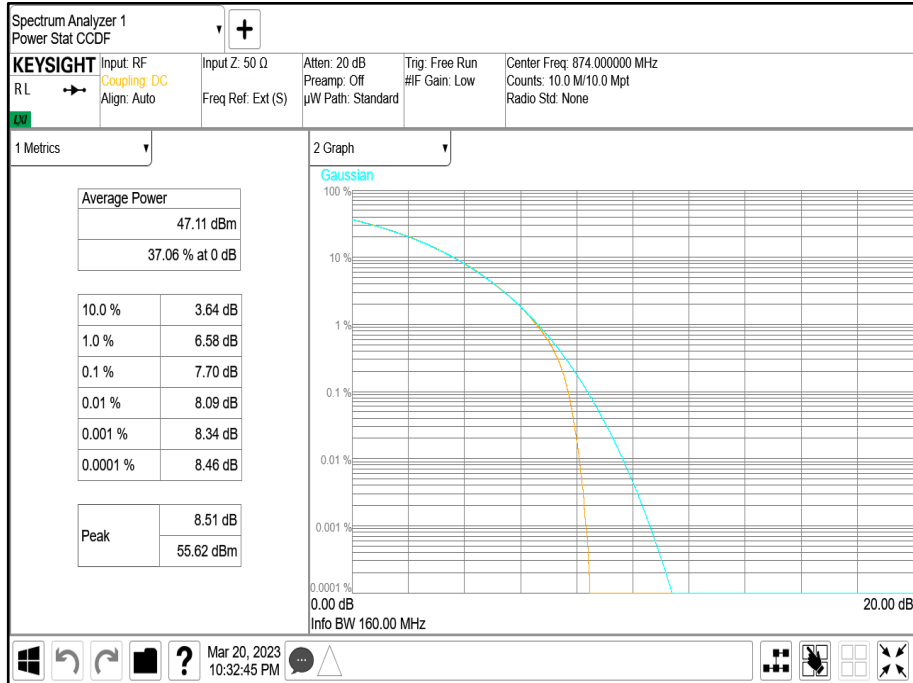

Configuration 11

Maximum Output Power 47.80 dBm

Antenna	LTE / NB-IOT GB Modulation	LTE / NB-IOT GB Carrier Bandwidth	Peak to Average Ratio (PAR) / Output Power / PSD										
			Channel Position M										
			PAR (dB)	Average Power/PSD		Total Power Port 1+2+3+4		Urban E.I.R.P Limit 820W/5MHz		Non Urban E.I.R.P Limit 1640W/5MHz		GANT* Urban	GANT* Non Urban
				dBm	dBm/MHz	dBm	dBm/MHz	dBm	dBm/MHz	dBm	dBm/MHz	dBm	dBm
2	QPSK	10.00 MHz	7.66	46.95	38.61	52.97	44.63	59.14	-	62.15	-	6.17	9.18



Antenna 2 - LTE / NB-IOT GB Modulation QPSK - LTE / NB-IOT GB Carrier Bandwidth 10.00 MHz - Channel Position M

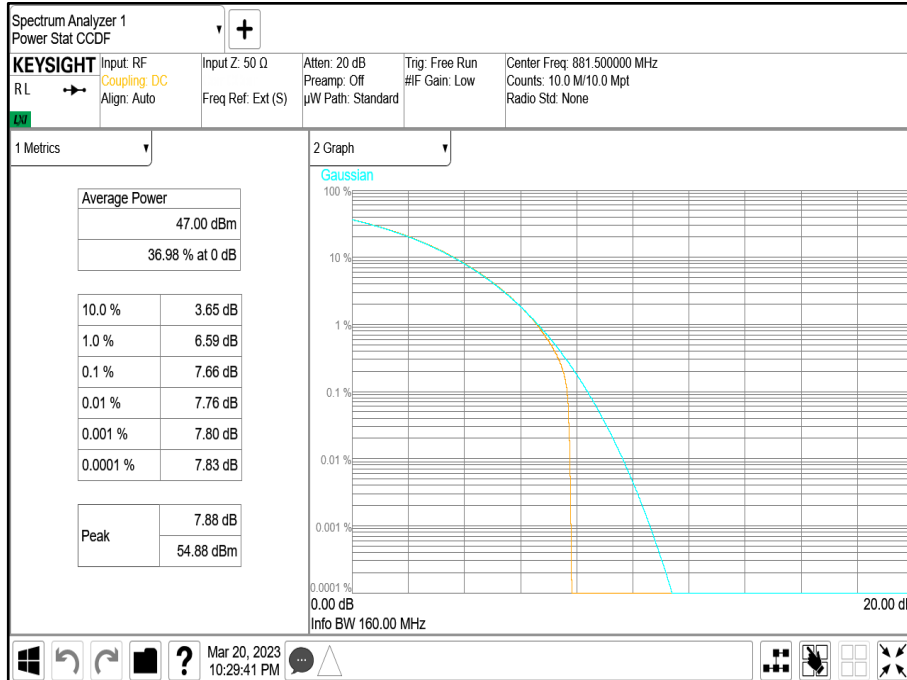

Configuration 11

Maximum Output Power 47.80 dBm

Antenna	LTE / NB-IOT GB Modulation	LTE / NB-IOT GB Carrier Bandwidth	Peak to Average Ratio (PAR) / Output Power / PSD										
			Channel Position T										
			PAR (dB)	Average Power/PSD		Total Power Port 1+2+3+4		Urban E.I.R.P Limit 820W/5MHz		Non Urban E.I.R.P Limit 1640W/5MHz		GANT* Urban	GANT* Non Urban
				dBm	dBm/MHz	dBm	dBm/MHz	dBm	dBm/MHz	dBm	dBm/MHz	dBi	dBi
2	QPSK	10.00 MHz	7.69	46.95	38.99	52.97	45.01	59.14	-	62.15	-	6.17	9.18



Antenna 2 - LTE / NB-IOT GB Modulation QPSK - LTE / NB-IOT GB Carrier Bandwidth 10.00 MHz - Channel Position T

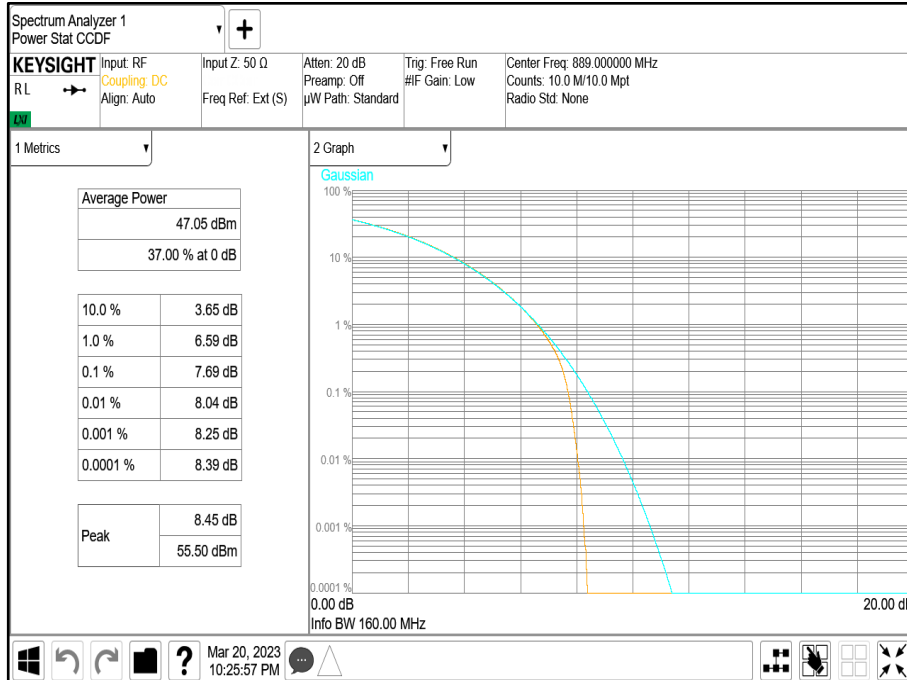

FCC Part 22.913(a) Clauses (i) & (i)

Limit	
Maximum ERP (Non-Urban)	≤ 800W/MHz - 2000 W/MHz (>72km from International Border)
	≤ 1000 W or ≤ 800W/MHz
Maximum ERP (Urban)	≤ 500 W or ≤ 400W/MHz
Peak to Average Ratio	13 dB

RSS-132 Clause 5.4

Limit	
Peak to Average Ratio	13 dB

SRSP-503 Power and Antenna Height Limitations Clause 5.1.1 & 5.1.2

Limit	
Maximum EIRP (Non-Urban)	≤ 1640 W/5MHz or ≤+62.15 dBm/5MHz or ≤+55.16 dBm/MHz
Maximum EIRP (Urban)	≤ 820 W/5MHz or ≤+59.15 dBm/5MHz or ≤+52.15 dBm/MHz



2.2 OCCUPIED BANDWIDTH

2.2.1 Specification Reference

FCC CFR 47 Part 22, Clause 22.917 (b)
ISED RSS-GEN, Clause 6.7
ISED RSS-132, Clause 5.5
FCC CFR 47 Part 2, Clause 2.1049

2.2.2 Date of Test and Modification State

08, 09, 10, 13, 16, 20, 21, 29, 31 March -2023 - Modification State 0

2.2.3 Test Equipment Used

The major items of test equipment used for the above tests are identified in Section 3.1.

2.2.4 Environmental Conditions

Ambient Temperature	22.0 - 22.8°C
Relative Humidity	38.6 - 39.8%

2.2.5 Test Method

All measurements were made in accordance with FCC KDB 971168 D01, Clause 4.2 and 4.3. The Spectrum Analyser RBW was configured to be at least 1% of the channel bandwidth of the carrier to be measured.

For 26 dB Bandwidth, in accordance with KDB 971168 D01, a peak detector and a trace setting of Max Hold were used. The trace was allowed to stabilise. Using the Spectrum Analyser function, the 26dB measurement result was obtained.

4.2 Occupied bandwidth – relative measurement procedure

The reference value is the highest level of the spectral envelope of the modulated signal, unless otherwise specified in an applicable rule section.

Subclause 5.4.3 of ANSI C63.26-2015 is applicable.

4.3 Occupied bandwidth – power bandwidth (99 %) measurement procedure

Subclause 5.4.4 of ANSI C63.26-2015 is applicable (wherein the recommendation is to use the 99 % power bandwidth function of a spectrum analyzer).

2.2.6 Test Results

Configuration 1

Maximum Output Power 47.80 dBm



Antenna	LTE Modulation	LTE Carrier Bandwidth	Result (kHz)					
			Channel Position B		Channel Position M		Channel Position T	
			Occupied Bandwidth	-26 dB Bandwidth	Occupied Bandwidth	-26 dB Bandwidth	Occupied Bandwidth	-26 dB Bandwidth
2	QPSK	5.0 MHz	4,484.48	4,794.12	4,481.95	4,797.58	4,483.22	4,801.73
2	QPSK	10.0 MHz	8,973.06	9,595.73	8,954.30	9,615.22	8,958.74	9,606.99

Antenna 2 - LTE Modulation QPSK - LTE Carrier Bandwidth 5.0 MHz - Channel Position B

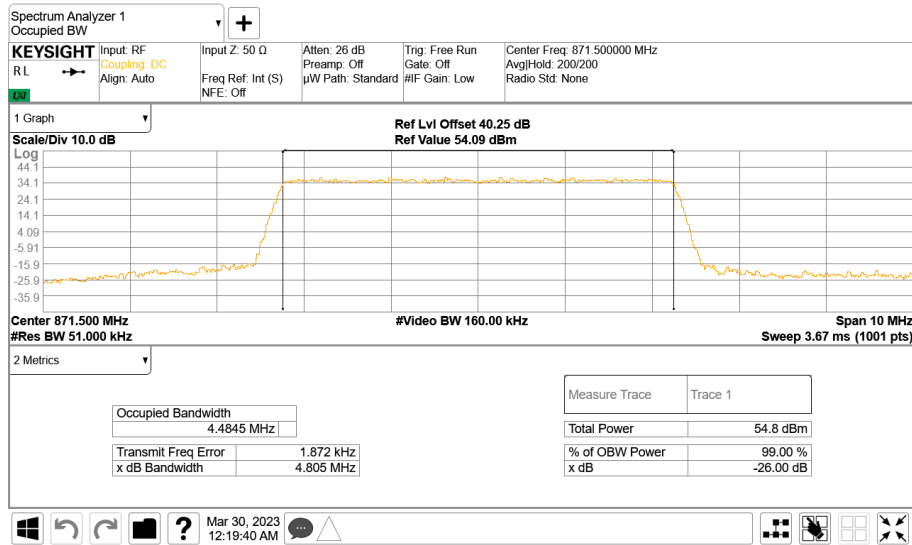

Antenna 2 - LTE Modulation QPSK - LTE Carrier Bandwidth 5.0 MHz - Channel Position M

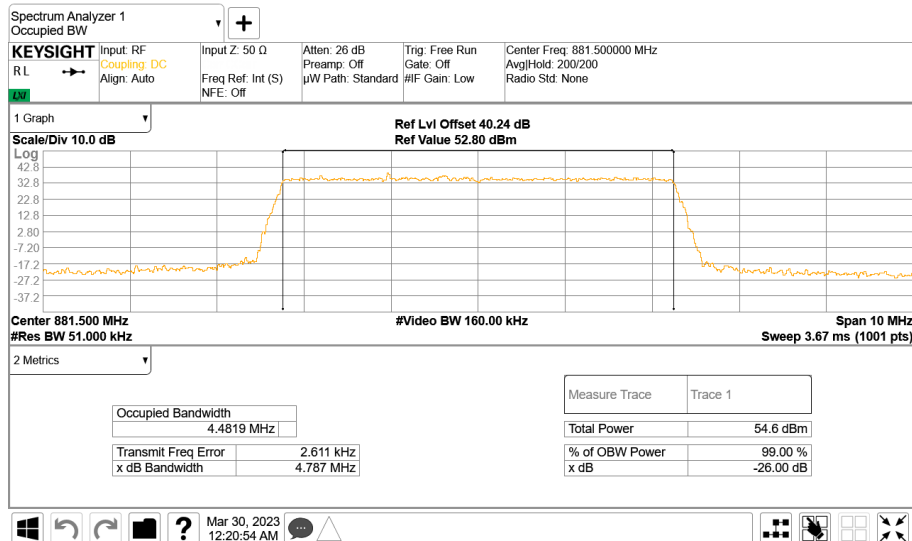



Antenna 2 - LTE Modulation QPSK - LTE Carrier Bandwidth 5.0 MHz - Channel Position T

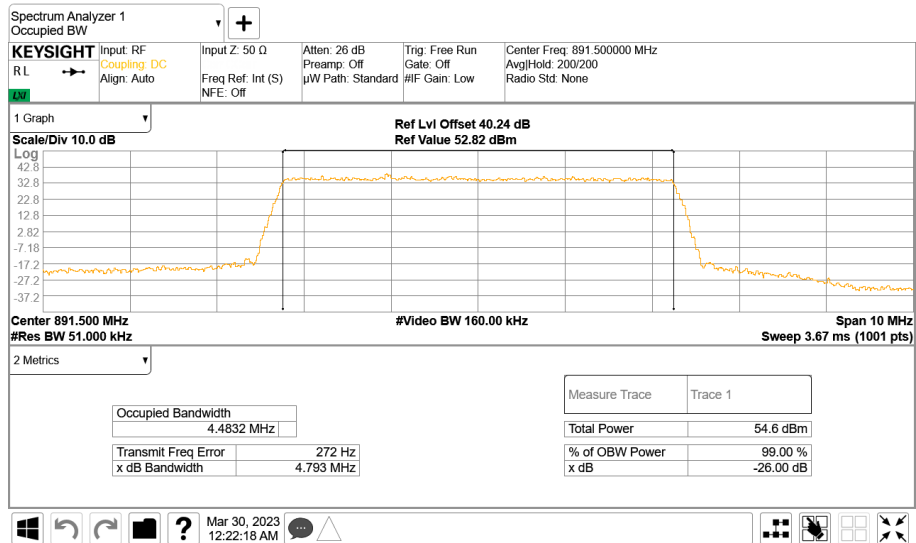

Antenna 2 - LTE Modulation QPSK - LTE Carrier Bandwidth 10.0 MHz - Channel Position B

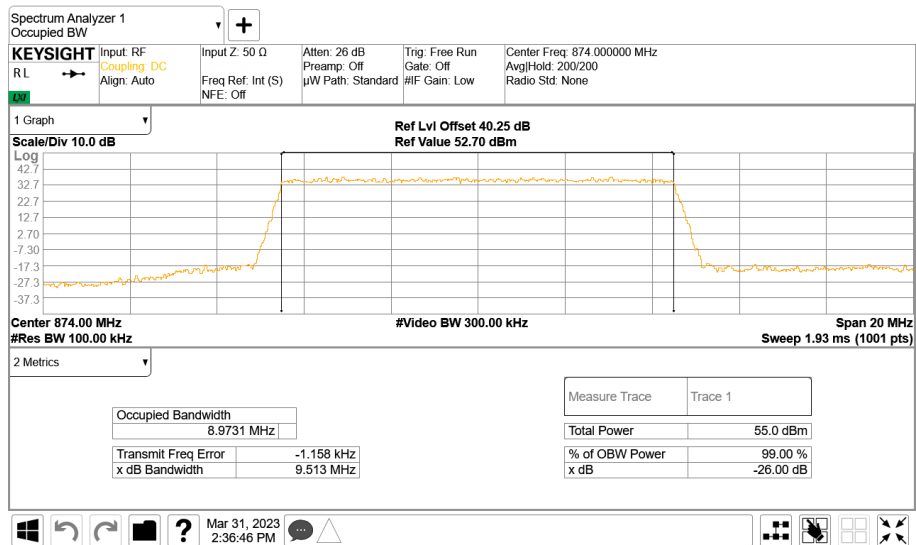



Antenna 2 - LTE Modulation QPSK - LTE Carrier Bandwidth 10.0 MHz - Channel Position M

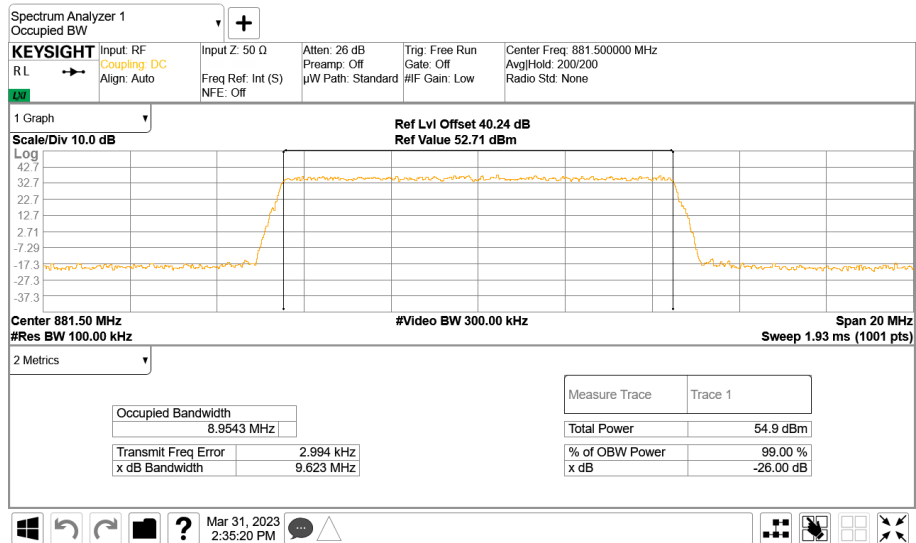

Antenna 2 - LTE Modulation QPSK - LTE Carrier Bandwidth 10.0 MHz - Channel Position T

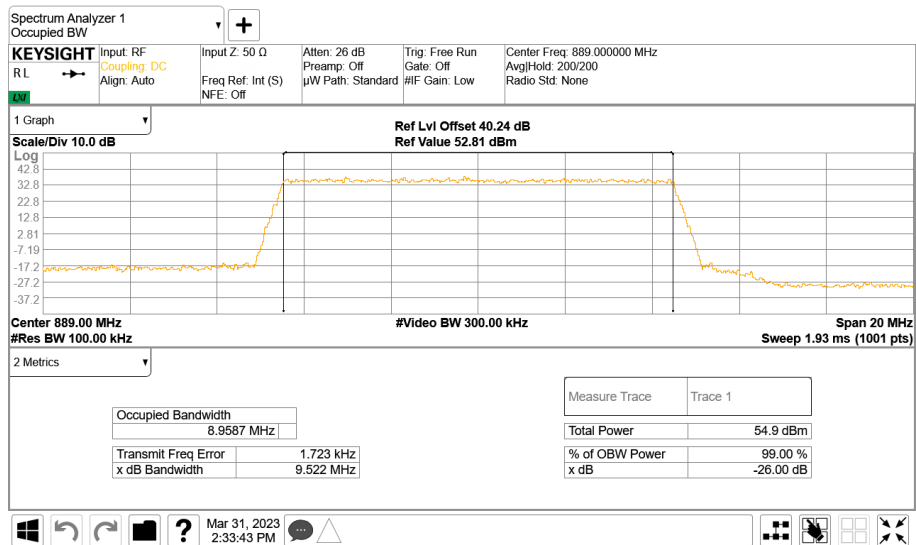



Configuration 2

Maximum Output Power 47.80 dBm

Antenna	LTE Modulation	LTE Carrier Bandwidth	Result (kHz)					
			Channel Position B		Channel Position M		Channel Position T	
			Occupied Bandwidth	-26 dB Bandwidth	Occupied Bandwidth	-26 dB Bandwidth	Occupied Bandwidth	-26 dB Bandwidth
2	QPSK	5.0 MHz	9465.30	9852.63	9454.56	9855.94	9472.17	9862.15
2	QPSK	10.0 MHz	18862.98	19648.96	18845.94	19631.01	18866.35	19634.88

Antenna 2 - LTE Modulation QPSK - LTE Carrier Bandwidth 5.0 MHz - Channel Position B

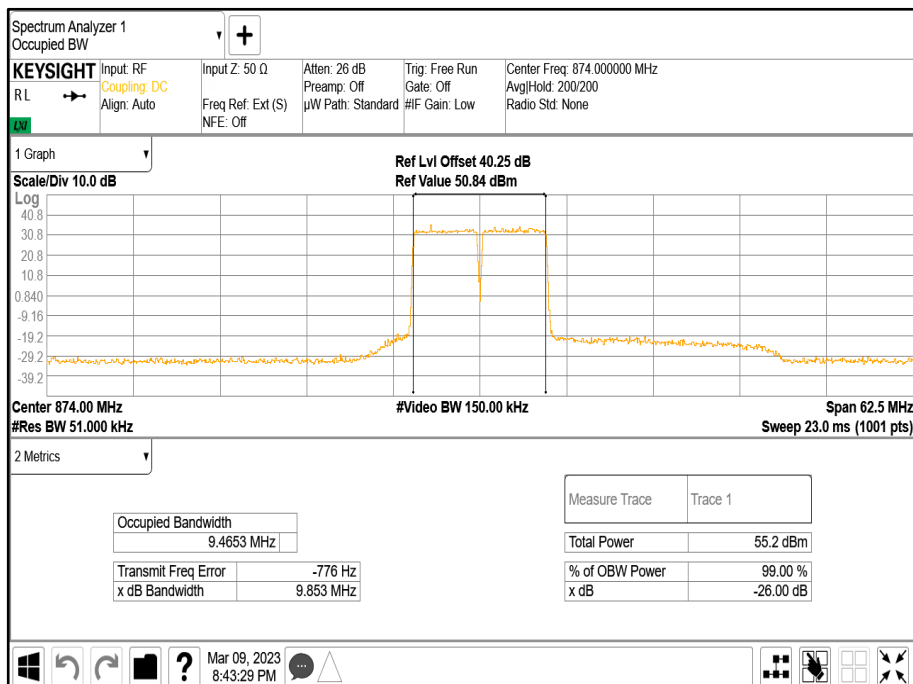



Antenna 2 - LTE Modulation QPSK - LTE Carrier Bandwidth 5.0 MHz - Channel Position M

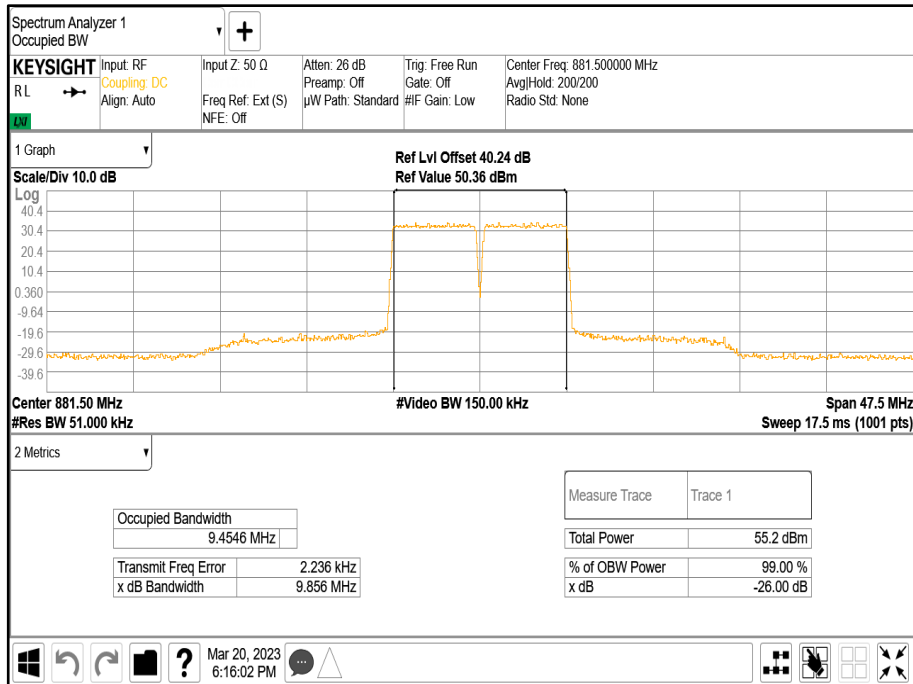

Antenna 2 - LTE Modulation QPSK - LTE Carrier Bandwidth 5.0 MHz - Channel Position T

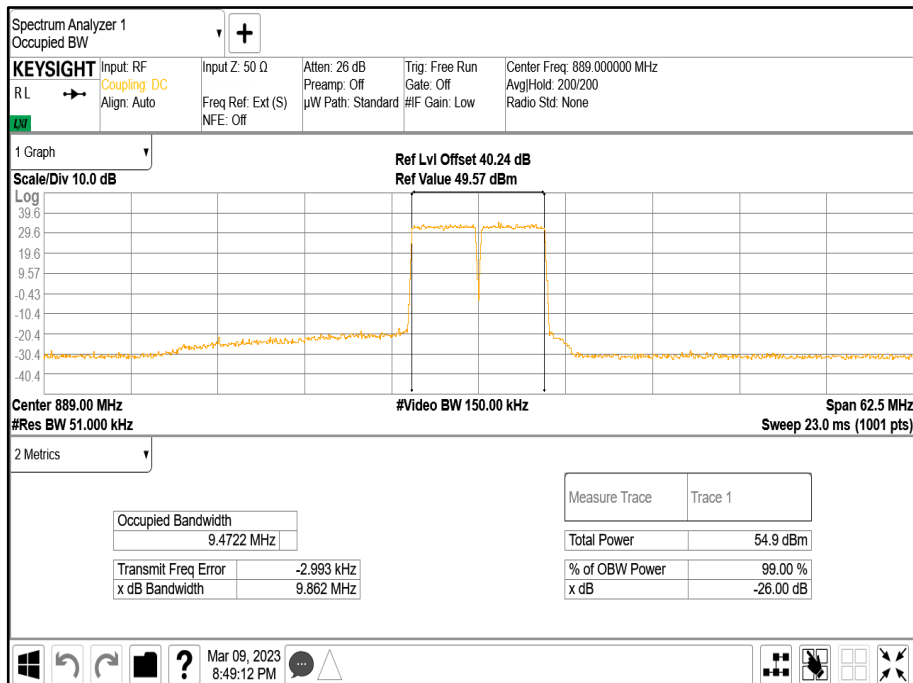



Antenna 2 - LTE Modulation QPSK - LTE Carrier Bandwidth 10.0 MHz - Channel Position B

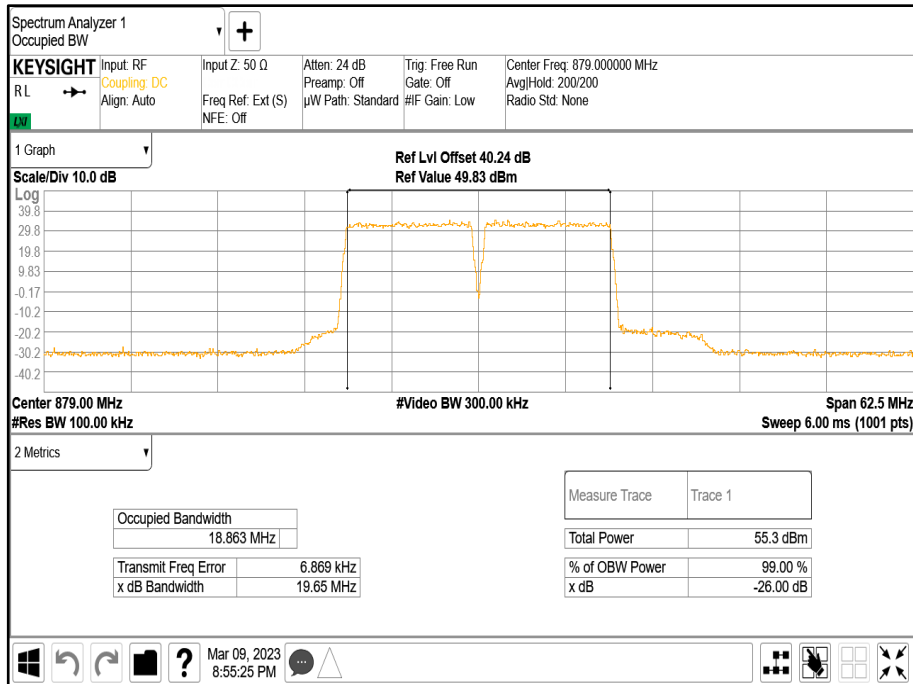

Antenna 2 - LTE Modulation QPSK - LTE Carrier Bandwidth 10.0 MHz - Channel Position M

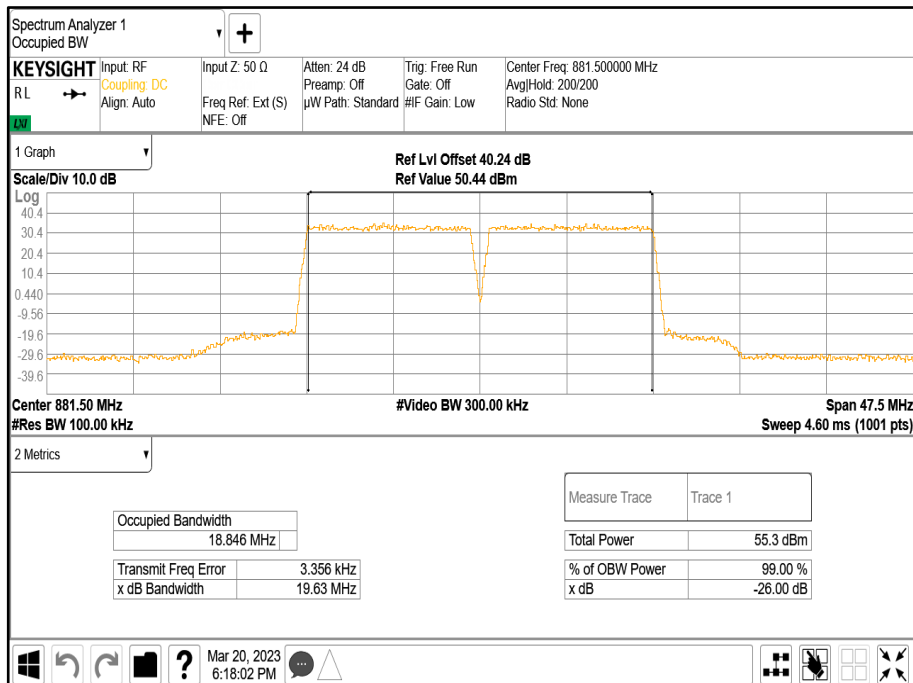



Antenna 2 - LTE Modulation QPSK - LTE Carrier Bandwidth 10.0 MHz - Channel Position T

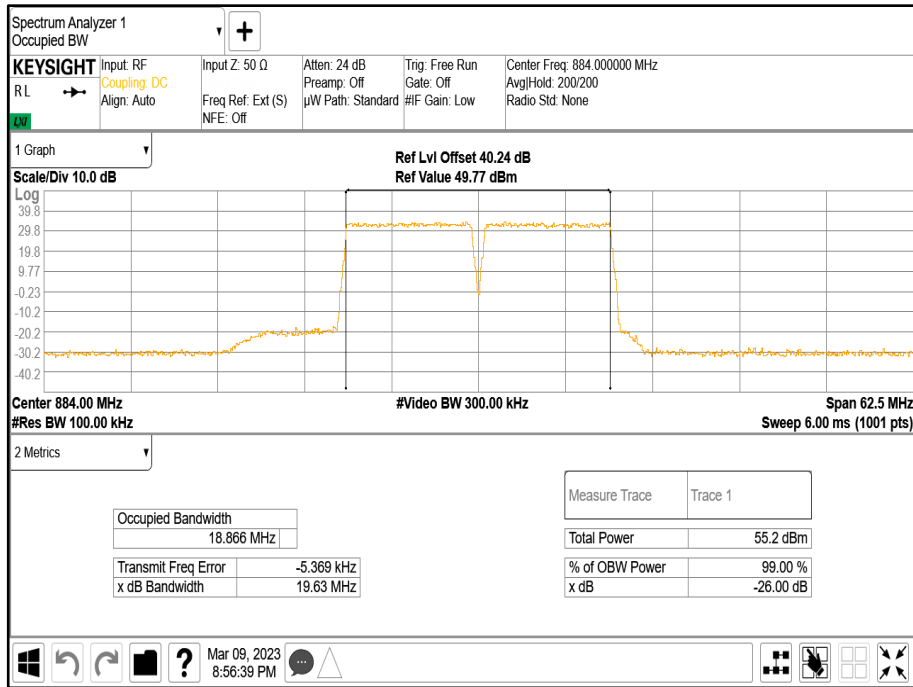

Configuration 3

Maximum Output Power 47.80 dBm

Antenna	LTE Modulation	LTE Carrier Bandwidth	Result (kHz)					
			Channel Position B		Channel Position M		Channel Position T	
			Occupied Bandwidth	-26 dB Bandwidth	Occupied Bandwidth	-26 dB Bandwidth	Occupied Bandwidth	-26 dB Bandwidth
2	QPSK	5.0 MHz	24291.07	24863.26	24273.53	24866.67	24295.23	24861.58



Antenna 2 - LTE Modulation QPSK - LTE Carrier Bandwidth 5.0 MHz - Channel Position B

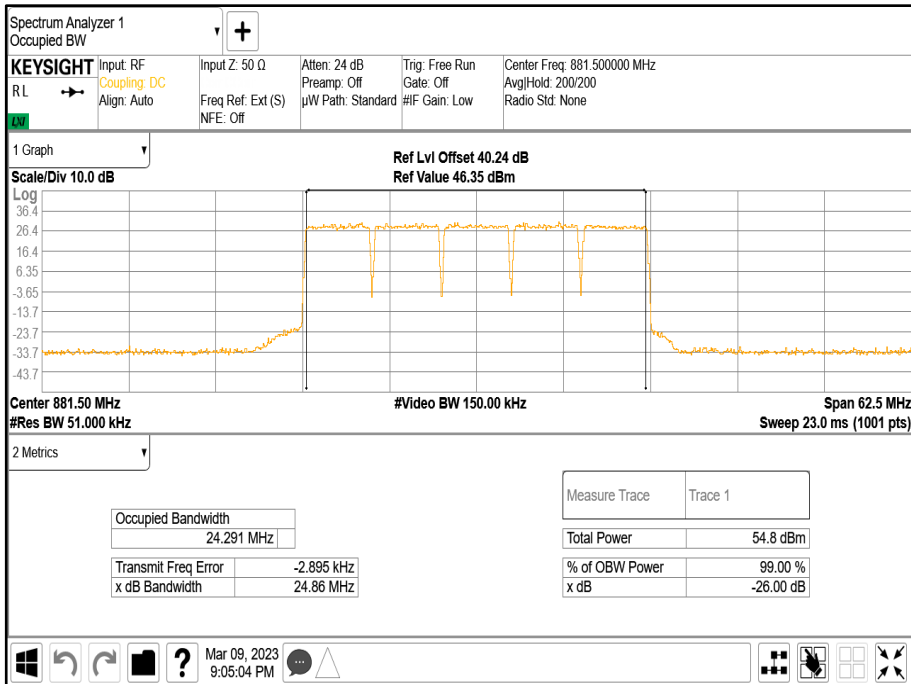

Antenna 2 - LTE Modulation QPSK - LTE Carrier Bandwidth 5.0 MHz - Channel Position M

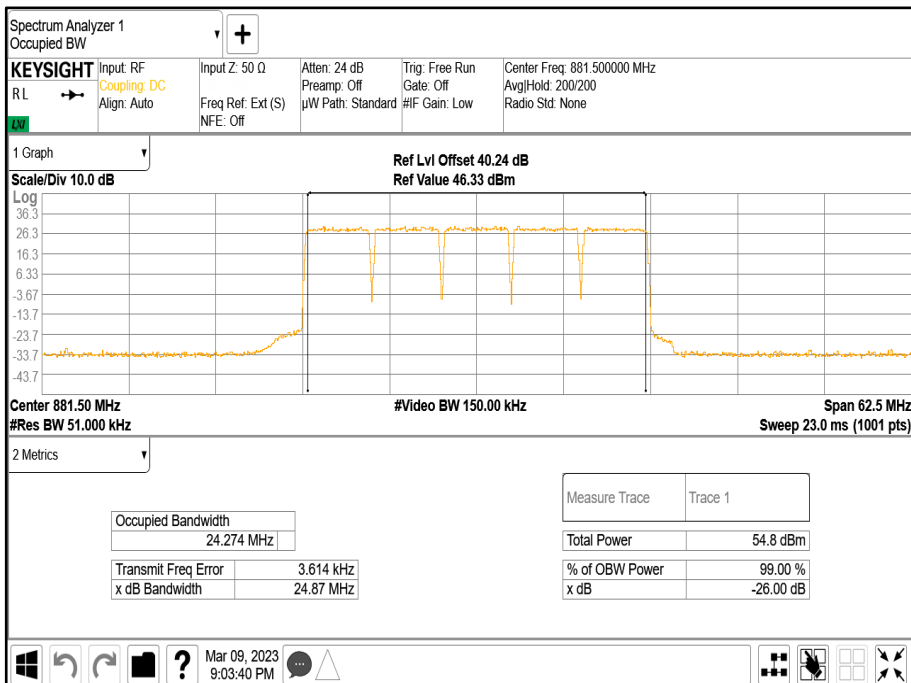



Antenna 2 - LTE Modulation QPSK - LTE Carrier Bandwidth 5.0 MHz - Channel Position T

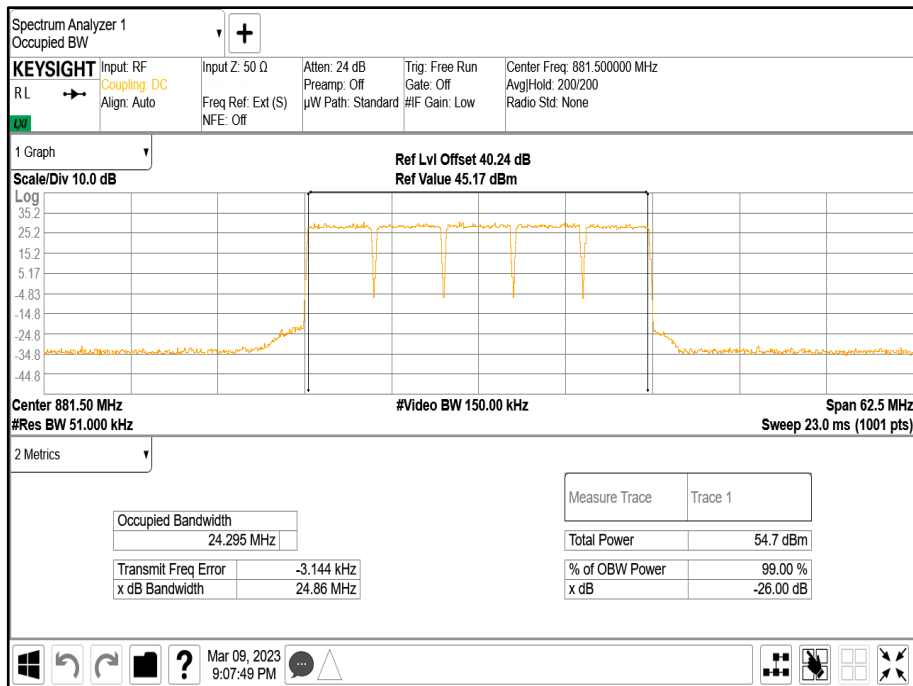

Configuration 4

Maximum Output Power 47.80 dBm

Antenna	NR Modulation	NR Carrier Bandwidth	Result (kHz)					
			Channel Position B		Channel Position M		Channel Position T	
			Occupied Bandwidth	-26 dB Bandwidth	Occupied Bandwidth	-26 dB Bandwidth	Occupied Bandwidth	-26 dB Bandwidth
2	QPSK	5.0 MHz 15 kHz SCS	4,486.03	4,773.67	4,473.69	4,781.77	4,471.00	4,778.21
2	QPSK	10.0 MHz 30 kHz SCS	8,639.21	9,607.37	8,589.39	9,661.17	8,597.27	9,627.05
2	QPSK	15.0 MHz 30 kHz SCS	13554.77	14707.16	13578.39	14739.79	13571.60	14690.54
2	QPSK	20.0 MHz 30 kHz SCS	18241.06	19672.63	18208.86	19715.12	18267.57	19634.84
2	QPSK	25.0 MHz 30 kHz SCS	23186.80	24618.34	-	-	-	-

Remarks

The IBW of this band is 25 MHz and therefore only one channel was performed at 25MHz bandwidth



Antenna 2 - NR Modulation QPSK - NR Carrier Bandwidth 5.0 MHz 15 kHz SCS - Channel Position B

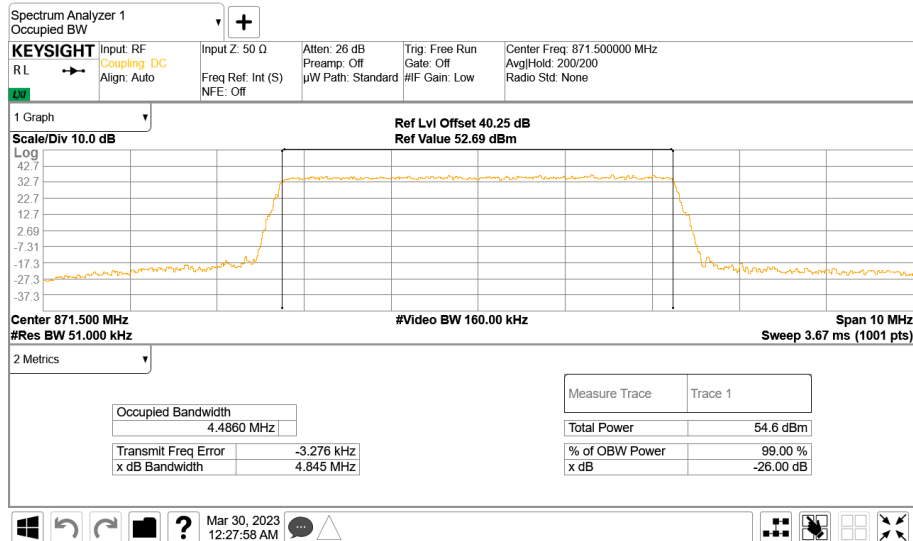

Antenna 2 - NR Modulation QPSK - NR Carrier Bandwidth 5.0 MHz 15 kHz SCS - Channel Position M

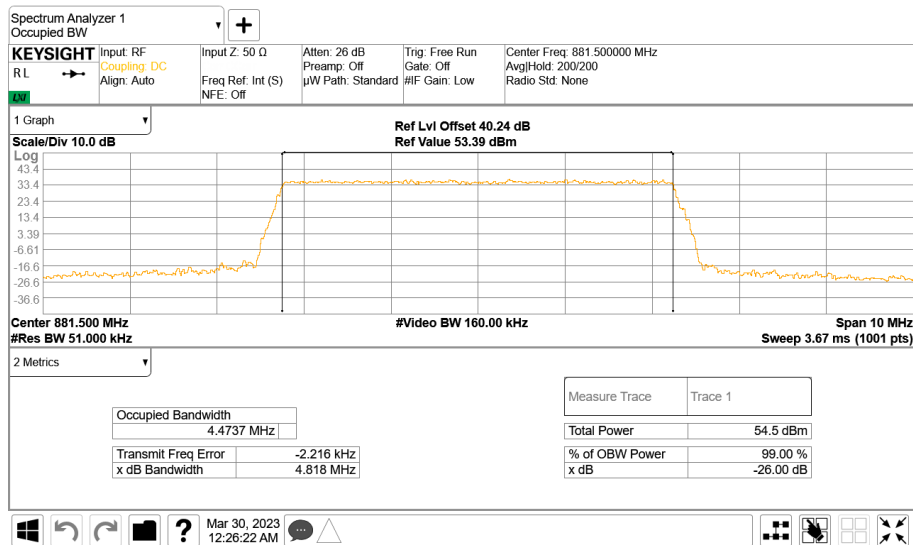



Antenna 2 - NR Modulation QPSK - NR Carrier Bandwidth 5.0 MHz 15 kHz SCS - Channel Position T

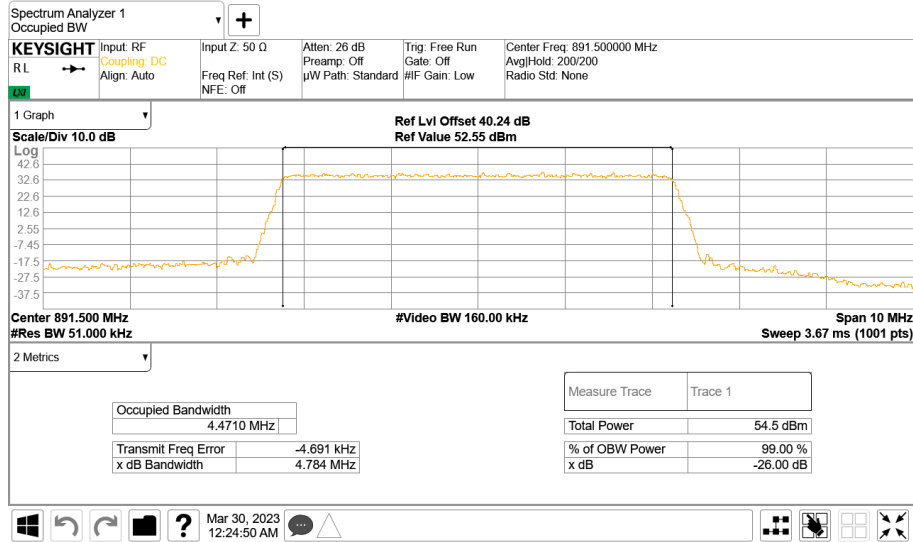

Antenna 2 - NR Modulation QPSK - NR Carrier Bandwidth 10.0 MHz 30 kHz SCS - Channel Position B

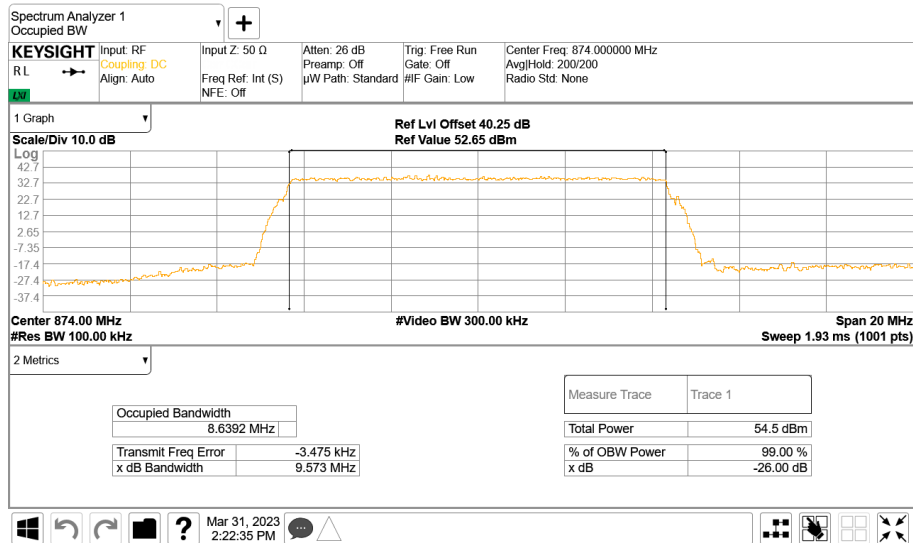



Antenna 2 - NR Modulation QPSK - NR Carrier Bandwidth 10.0 MHz 30 kHz SCS - Channel Position M

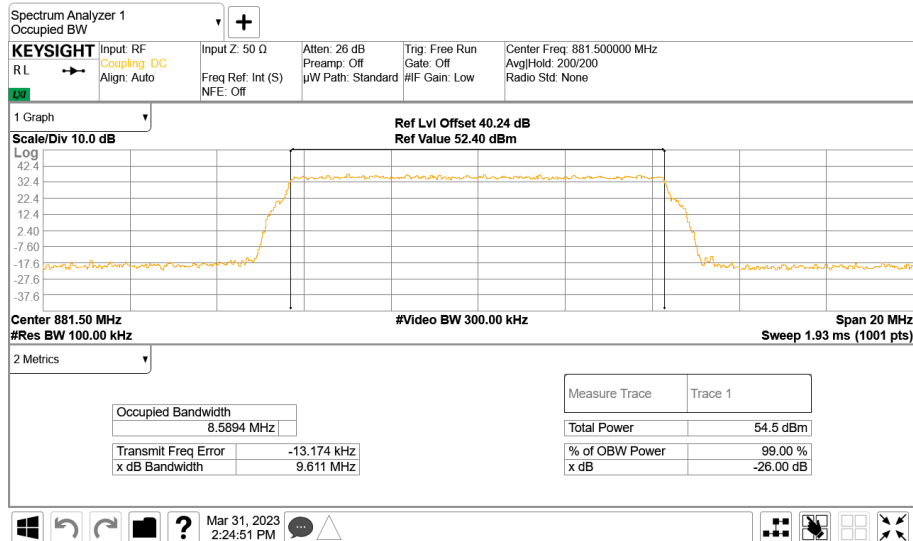

Antenna 2 - NR Modulation QPSK - NR Carrier Bandwidth 10.0 MHz 30 kHz SCS - Channel Position T

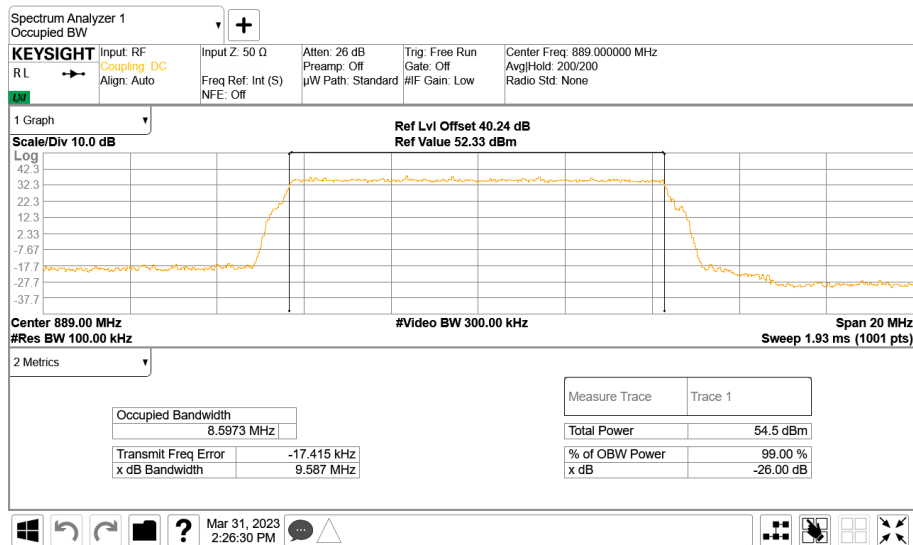



Antenna 2 - NR Modulation QPSK - NR Carrier Bandwidth 15.0 MHz 30 kHz SCS - Channel Position B

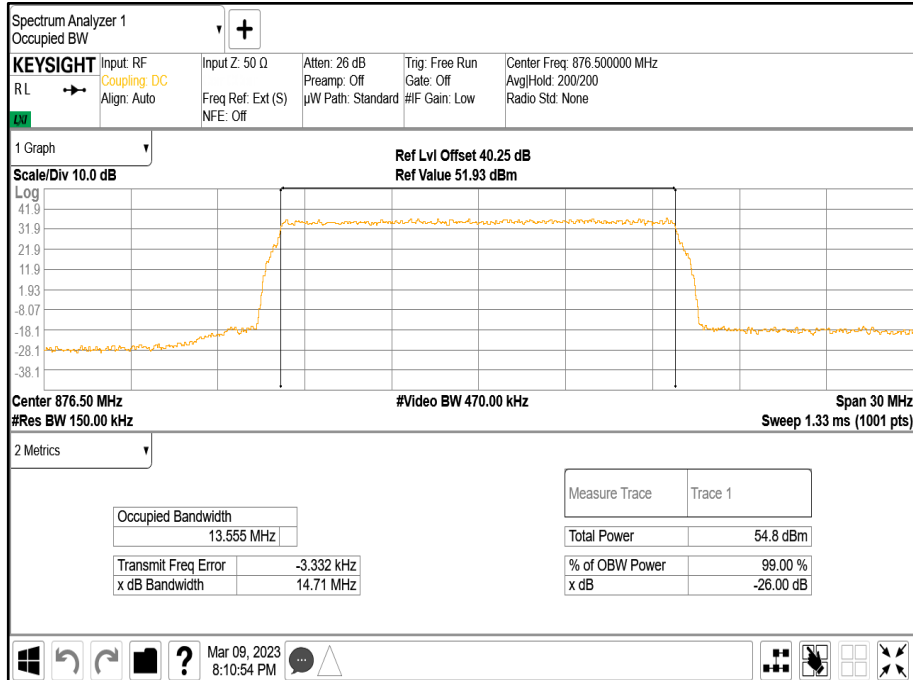

Antenna 2 - NR Modulation QPSK - NR Carrier Bandwidth 15.0 MHz 30 kHz SCS - Channel Position M

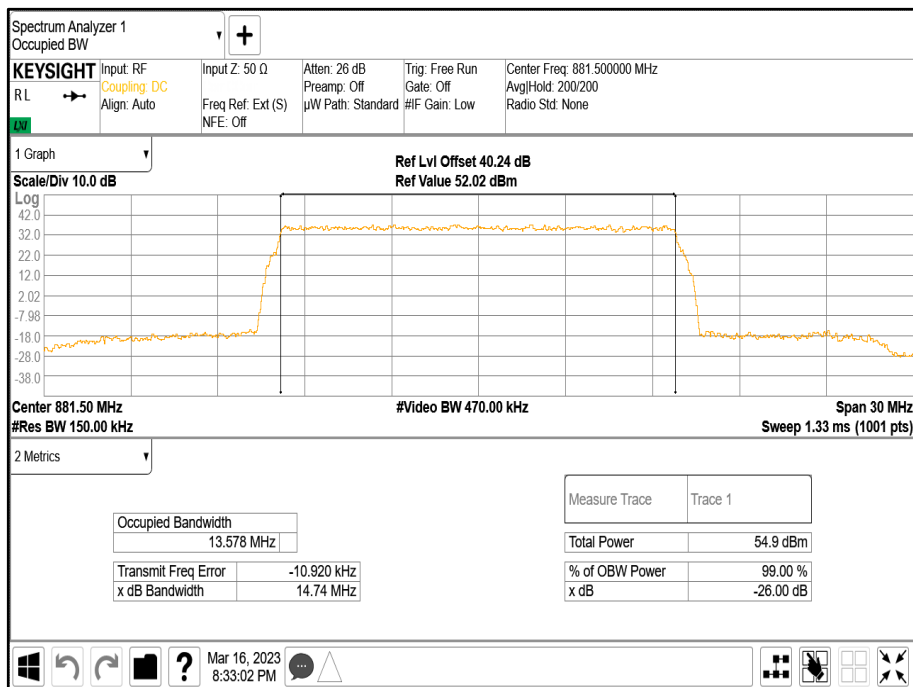



Antenna 2 - NR Modulation QPSK - NR Carrier Bandwidth 15.0 MHz 30 kHz SCS - Channel Position T

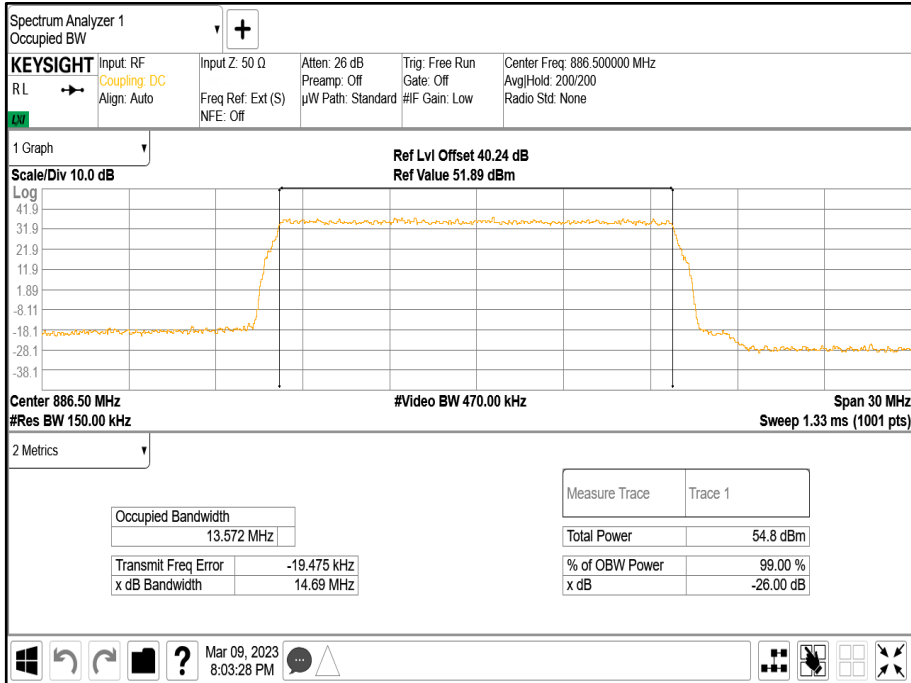

Antenna 2 - NR Modulation QPSK - NR Carrier Bandwidth 20.0 MHz 30 kHz SCS - Channel Position B

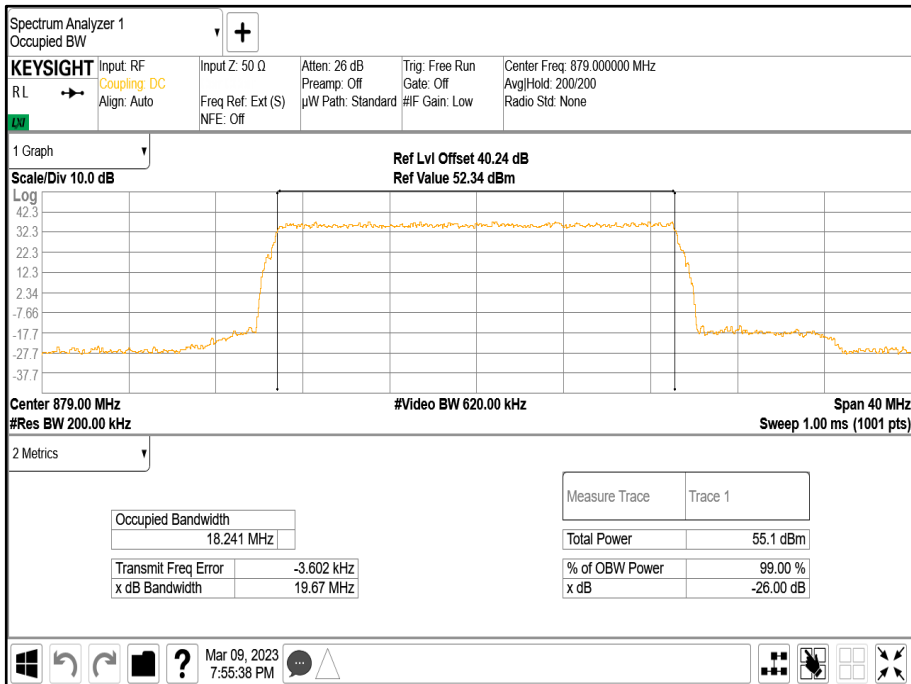



Antenna 2 - NR Modulation QPSK - NR Carrier Bandwidth 20.0 MHz 30 kHz SCS - Channel Position M

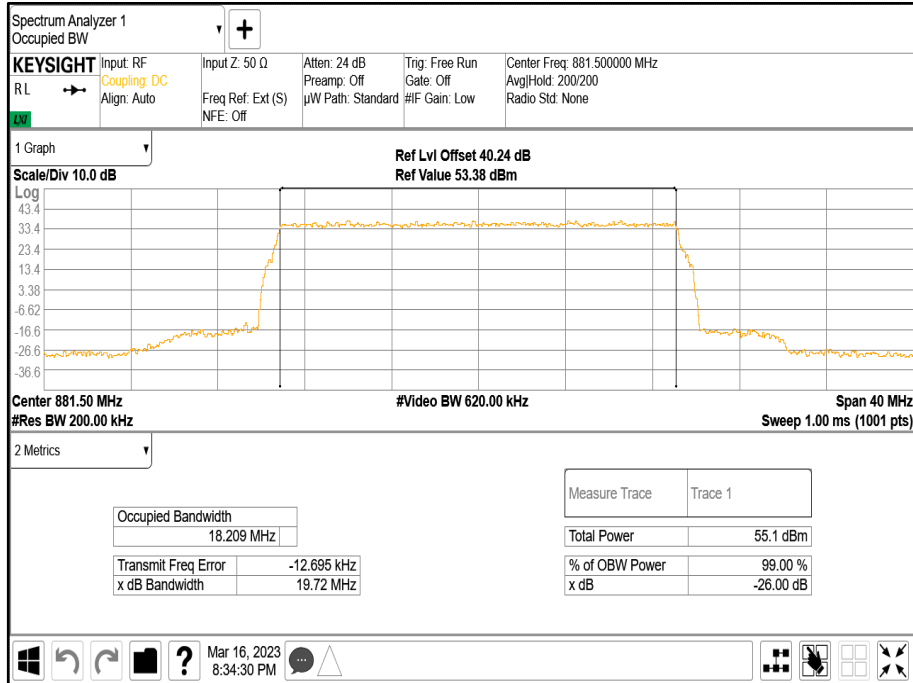

Antenna 2 - NR Modulation QPSK - NR Carrier Bandwidth 20.0 MHz 30 kHz SCS - Channel Position T

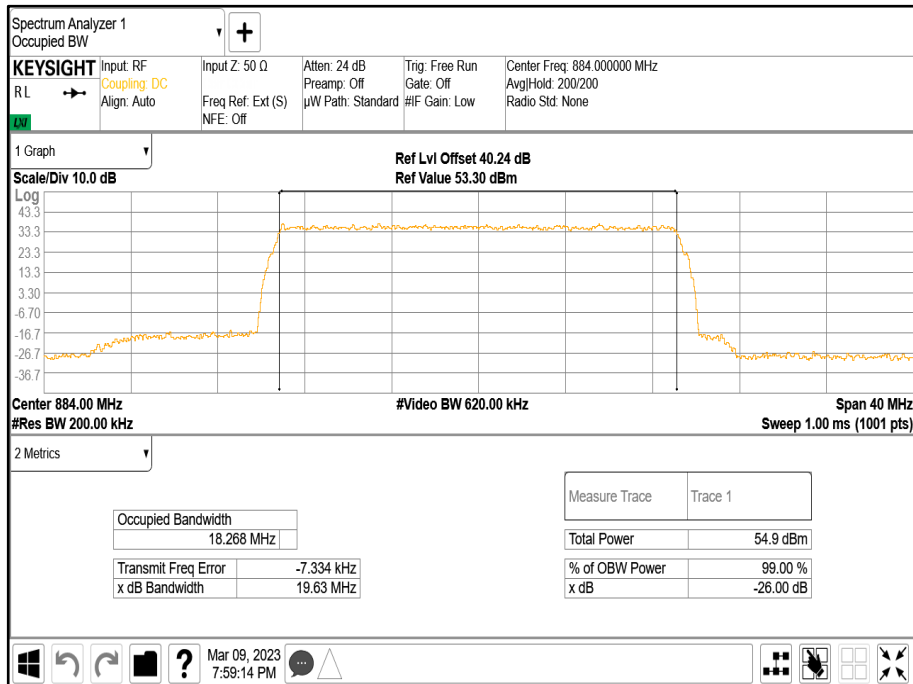



Antenna 2 - NR Modulation QPSK - NR Carrier Bandwidth 25.0 MHz 30 kHz SCS - Channel Position B

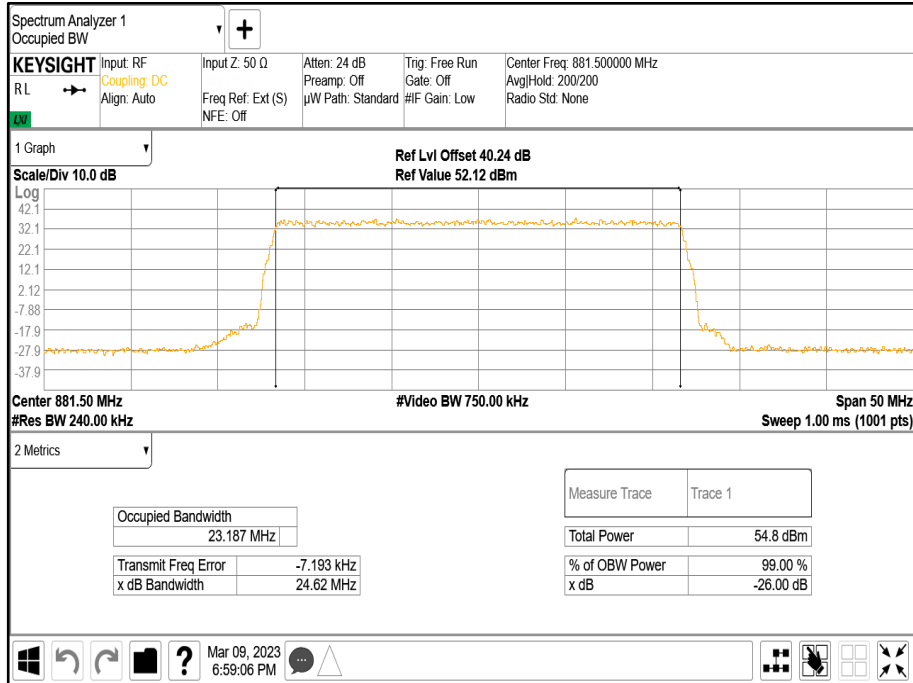

Configuration 5

Maximum Output Power 47.80 dBm

Antenna	NR Modulation	NR Carrier Bandwidth	Result (kHz)					
			Channel Position B		Channel Position M		Channel Position T	
			Occupied Bandwidth	-26 dB Bandwidth	Occupied Bandwidth	-26 dB Bandwidth	Occupied Bandwidth	-26 dB Bandwidth
2	QPSK	5.0 MHz 15 kHz SCS	9438.18	9862.90	9448.81	9860.88	9459.99	9857.75
2	QPSK	10.0 MHz 30 kHz SCS	18519.80	19633.40	18513.24	19676.48	18527.17	19673.29