

Ericsson AB

RF TEST REPORT

Report Type:

FCC Part 27 RF report

PRODUCT NAME:

Radio 4480 44B71 44B85A C

REPORT NUMBER:

240100802SHA-001

ISSUE DATE:

January 25, 2024

DOCUMENT CONTROL NUMBER:

TTRFFCC Part 27_V1 © 2018 Intertek



Applicant: Ericsson AB
Isafjordsgatan 10 SE-164 80 Stockholm 16480 Sweden

Manufacturer: Ericsson AB
Isafjordsgatan 10 SE-164 80 Stockholm 16480 Sweden

FCC ID: TA8AKRC161922

IC: 287AB-AS161922

SUMMARY:

The equipment complies with the requirements according to the following standard(s) or Specification:

FCC CFR 47 Part 27: MISCELLANEOUS WIRELESS COMMUNICATIONS SERVICES

RSS-130 Issue 2: Equipment Operating in the Frequency Bands 617-652 MHz, 663-698 MHz, 698-756 MHz and 777-787 MHz

PREPARED BY:



Project Engineer
Victor Yang

REVIEWED BY:

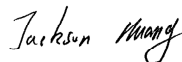

Reviewer
Jackson Huang

This report is for the exclusive use of Intertek's Client and is provided pursuant to the agreement between Intertek and its Client. Intertek's responsibility and liability are limited to the terms and conditions of the agreement. Intertek assumes no liability to any party, other than to the Client in accordance with the agreement, for any loss, expense or damage occasioned by the use of this report. Only the Client is authorized to permit copying or distribution of this report and then only in its entirety. Any use of the Intertek name or one of its marks for the sale or advertisement of the tested material, product or service must first be approved in writing by Intertek. The observations and test results in this report are relevant only to the sample tested. This report by itself does not imply that the material, product, or service is or has ever been under an Intertek certification program.

TEST REPORT

Content

REVISION HISTORY	4
MEASUREMENT RESULT SUMMARY	5
1 GENERAL INFORMATION	6
1.1 DESCRIPTION OF EQUIPMENT UNDER TEST (EUT)	6
1.2 TECHNICAL SPECIFICATION	7
1.3 DESCRIPTION OF TEST FACILITY	8
2 TEST SPECIFICATIONS	9
2.1 RELATED DOCUMENTS	9
2.2 PRODUCT INFORMATION.....	9
2.3 CONFIGURATION DESCRIPTION.....	10
2.4 TEST SETUP.....	11
2.5 TEST ENVIRONMENT CONDITION:.....	12
2.6 INSTRUMENT LIST	13
2.7 MEASUREMENT UNCERTAINTY	14
3 MAXIMUM OUTPUT POWER AND PEAK TO AVERAGE POWER RATIO AND EIRP	15
3.1 LIMIT	15
3.2 MEASUREMENT PROCEDURE	16
3.3 MEASUREMENT RESULT	17
4 OCCUPIED BANDWIDTH	25
4.1 MEASUREMENT PROCEDURE	25
4.2 MEASUREMENT RESULT	26
5 UNWANTED EMISSIONS AT BAND EDGE	30
5.1 LIMIT	30
5.2 MEASUREMENT PROCEDURE	30
5.3 MEASUREMENT RESULT	31
6 CONDUCTED UNWANTED EMISSION	35
6.1 LIMIT	35
6.2 MEASUREMENT PROCEDURE	35
6.3 MEASUREMENT RESULT	36
7 FREQUENCY STABILITY	50
7.1 LIMIT.....	50
7.2 MEASUREMENT PROCEDURE	50
7.3 MEASUREMENT RESULT	51

Revision History

Report No.	Version	Description	Issued Date
240100802SHA-001	Rev. 01	Initial issue of report	January 25, 2024

Measurement result summary

TEST ITEM	FCC REFERANCE	IC REFERANCE	RESULT
Max Output Power and Peak to Average Power Ratio and EIRP	27.50(d)	RSS-130 4.6	Pass
Occupied Bandwidth	27.53(g) 2.1049	RSS-GEN 6.7	Pass
Unwanted Emissions at Band Edge	27.53(g)	RSS-130 4.7	Pass
Conducted Unwanted Emission	27.53(g)	RSS-130 4.7	Pass
Frequency Stability	27.54	RSS-130 4.5	Pass

1 GENERAL INFORMATION

1.1 Description of Equipment Under Test (EUT)

Description:	Remote Radio Unit
Product name:	Radio 4480 44B71 44B85A C
Product number:	KRC 161 922/1
HVIN	AS161922
Serial Number(s)	E23E285588
Rating:	-48V DC
Software Version:	CXP9013268%15_R97BE
Hardware Version:	R2A
Sample received date:	January 10, 2024
Date of test:	January 10, 2024 ~ January 15, 2024

1.2 Technical Specification

Frequency Range:	B71: TX (DL): 617-652MHz; RX (UL): 663-698MHz B85A: TX (DL): 728-745MHz; RX (UL): 698-715MHz
Number of Antenna ports:	4 TX/RX
Supported RAT:	Single RAT: LTE, NR, NB-IoT (IB, GB, SA) Multi RAT: LTE+ NR; LTE+ NB-IoT SA; NR +NB-IoT SA, LTE+ NR + NB-IoT SA
Max RF bandwidth (IBW):	B71:35MHz B85A:17MHz
Supported Number of Carriers:	Max 6 carriers
Supported modulation:	LTE/NR: QPSK, 16QAM, 64QAM, 256QAM NB IoT SA/ GB/ IB: QPSK, BPSK (BPSK is for up link only)
Supported Channel Bandwidth:	B71: NR: 5MHz, 10MHz, 15MHz, 20MHz, 25MHz, 30MHz, 35MHz; LTE:5MHz, 10MHz, 15MHz, 20MHz; NB-IoT(SA): 200 kHz B85A: NR: 5MHz, 10MHz, 15MHz LTE:5MHz, 10MHz NB-IoT(SA): 200 kHz
Declaration output power:	B71: 60 W per band B85A: 40 W per band Both bands: With fan 100 W, Without fan 80 W B71: 5 MHz: 40 W 10, 15, 20, 25, 30, 35 MHz: 60 W NB IoT SA: 20 W B85A: 5, 10, 15 MHz: 40 NB IoT SA: 20 W

Note: Information in the 1.2 sheet declared by the manufacturer.

1.3 Description of Test Facility

Conducted testing:

Name:	Intertek Testing Services Shanghai
Address 1:	Building 86, No. 1198 Qinzhou Road(North), Shanghai 200233, P.R. China
Address 2:	No. 5 Lize East Street, Ericsson Tower, Chaoyang District, Beijing 100102 P.R.C.
Telephone:	+86 21 61278200
Telefax:	+86 21 54262353
The test facility is recognized, certified, or accredited by these organizations:	FCC Accredited Lab Designation Number: CN0175
	IC Registration Lab CAB identifier.: CN0014
	A2LA Accreditation Lab Certificate Number: 3309.02

2 TEST SPECIFICATIONS

2.1 Related documents

FCC Part 27 (2022)

FCC Part 2 (2022)

RSS-130 issue 2 February 2019

ISED RSS-Gen issue 5 March 2019 Amendment 1 February 2021 Amendment 2

ANSI C63.26:2015

KDB 971168 D01 v03r01

KDB 662911 D01 v02r01

2.2 Product Information

The Equipment Under Test (EUT) is an Ericsson Remote Radio Unit working in the wireless communications services 617-652MHz & 728-745MHz band which provides communication connections to network in LTE, NR, NB-IoT (IB, GB, SA) modes and MSR modes. The Radio 4480 44B71 44B85A C operates from a -48V DC power supply.

The EUT includes 4 TX/RX ports and it can be configured to transmit in MIMO mode, and MIMO mode was used for measurements as the worst configuration. The complete testing was performed with the EUT transmitting at maximum RF power unless otherwise stated.

A full technical description can be found in the Manufacturer's documentation.

2.3 Configuration Description

The following settings were used to represent all traffic scenarios. The output power was measured on the bottom, middle and top channel of all applicable antenna ports. By measuring the output power of QPSK, 16QAM, 64QAM and 256QAM on one of the antenna ports, it was determined that 16QAM for NR was the worst case modulation schemes and were used for all testing.

Complete testing was carried out on the worst case antenna port which was established as being the highest output power from the 4 measured ports on worst case modulation scheme. This antenna port was Port C for all modes.

The settings below were used for all measurements unless otherwise noted:

B71 NR

Configuration	Carrier	NR Carrier BW(MHz)	Carrier Frequency Configuration		
			Bottom	Middle	Top
NR-1C	1	25	629.5	634.5	639.5
		30	632	634.5	637
		35	-	634.5	-

B71 NR

Configuration	Carrier	NR Carrier BW(MHz)	Carrier Frequency Configuration		
			Bottom	Middle	Top
NR-1C-BE	1	25	629.5	-	639.5
		30	632	-	637
		35	-	634.5	-

2.4 Test Setup

Conducted Measurement:

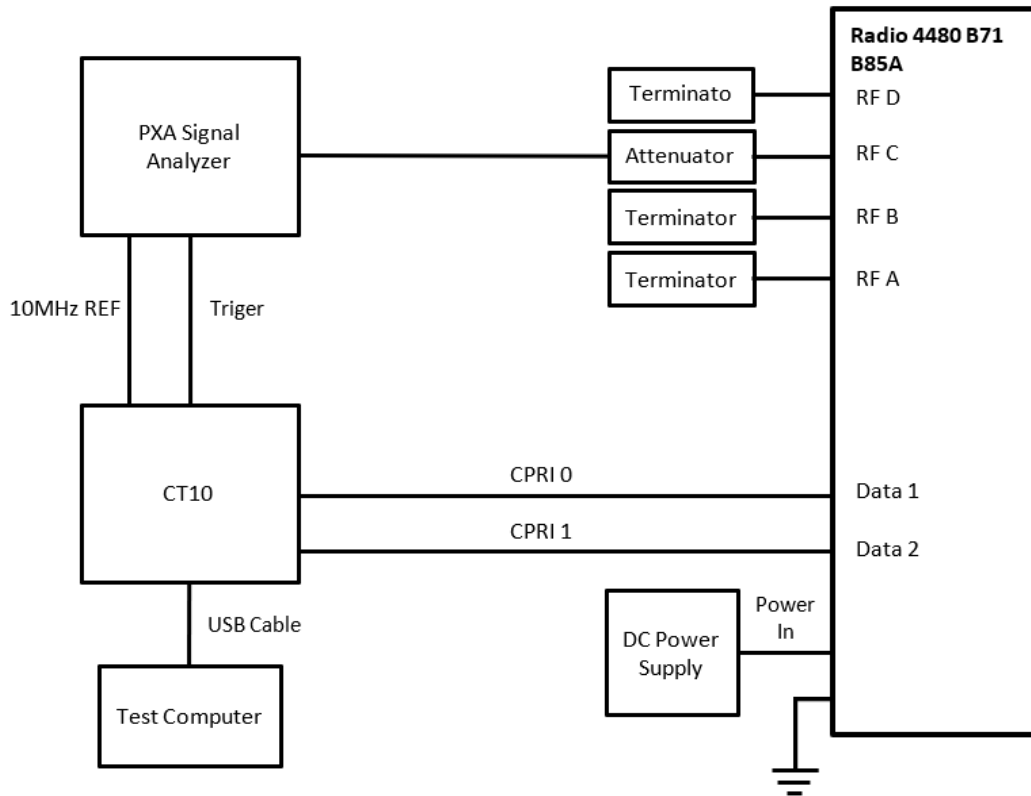

No.	Auxiliary Equipment	Product Number / Model Type	Version
1	Test computer	Precision 3560	-
2	CT10	LPC 102487/1	R1C
3	DC Power Supply N8737A	US21E7359S	-
4	300W 40db Attenuator	US21E7359S	-
5	250W Terminator	A220320237	-
6	250W Terminator	A220320241	-
7	250W Terminator	A220320242	-
8	SPE Test Kit Box	BAMS-1017018157	-

Proper Attenuator will be chosen to use in relative test case. And the cable loss of specified Attenuator with connect cable will be calibrated before test for relative frequency range and the worst reading will be used as offset in the relative test case.

2.5 Test environment condition:

Test items	Temperature	Humidity
Max Output Power and Peak to Average Power Ratio and EIRP	21°C	54% RH
Occupied Bandwidth		
Unwanted Emissions at Band Edge		
Conducted Unwanted Emission		
Frequency Stability	Please refer to clause 8	

2.6 Instrument list

Intertek Testing Services					
Used	Equipment	Manufacturer	Type	S/N	Due date
<input checked="" type="checkbox"/>	PXA Signal Analyzer	Keysight	N9030A	EC1046	2024.4.7
<input type="checkbox"/>	Signal Generator	R&S	SMU200A	EC1050	2024.4.2
<input checked="" type="checkbox"/>	Multi-meter	Fluke	117	EC1051	2024.2.5
<input checked="" type="checkbox"/>	Climatic Chamber	赛宝	CEEC-WR16H-50W	EC1052	2024.8.28
<input checked="" type="checkbox"/>	Humiture meter	托普	TPJ-20	EC1053	2024.2.21

2.7 Measurement uncertainty

The measurement uncertainty represents an expanded uncertainty expressed at approximately the 95% confidence level using a coverage factor of k=2.

Test item	Measurement uncertainty
Maximum output power	0.73dB
Occupied Bandwidth	0.88%
Unwanted Emissions at Band Edge	3.03dB
Conducted Unwanted Emission	3.03dB
Frequency stability	0.77×10^{-7}

TEST REPORT

3 Maximum Output Power and Peak to Average Power Ratio and EIRP

Test result: Pass

3.1 Limit

FCC CFR 47 Part 27:

(1) Fixed and base stations transmitting a signal with an emission bandwidth of 1 MHz or less must not exceed an effective radiated power (ERP) of 1000 watts and an antenna height of 305 m height above average terrain (HAAT), except that antenna heights greater than 305 m HAAT are permitted if power levels are reduced below 1000 watts ERP in accordance with Table 1 of this section;

Antenna height (AAT) in meters (feet)	Effective radiated power (ERP) (watts)
Above 1372 (4500)	65
Above 1220 (4000) To 1372 (4500)	70
Above 1067 (3500) To 1220 (4000)	75
Above 915 (3000) To 1067 (3500)	100
Above 763 (2500) To 915 (3000)	140
Above 610 (2000) To 763 (2500)	200
Above 458 (1500) To 610 (2000)	350
Above 305 (1000) To 458 (1500)	600
Up to 305 (1000)	1000

(2) Fixed and base stations transmitting a signal with an emission bandwidth greater than 1 MHz must not exceed an ERP of 1000 watts/MHz and an antenna height of 305 m HAAT, except that antenna heights greater than 305 m HAAT are permitted if power levels are reduced below 1000 watts/MHz ERP in accordance with Table 3 of this section;

Antenna height (AAT) in meters (feet)	Effective radiated power (ERP) per MHz (watts/MHz)
Above 1220 (4000) To 1372 (4500)	70
Above 1067 (3500) To 1220 (4000)	75
Above 915 (3000) To 1067 (3500)	100
Above 763 (2500) To 915 (3000)	140
Above 610 (2000) To 763 (2500)	200
Above 458 (1500) To 610 (2000)	350
Above 305 (1000) To 458 (1500)	600
Up to 305 (1000)	1000

RSS-130 Issue 2:

For fixed and base stations transmitting in accordance with section 4, the maximum permissible equivalent isotropically radiated power (e.i.r.p.) is 1640 watts and 1640 watts/MHz for a channel bandwidth less than or equal to 1 MHz and greater than 1 MHz, respectively. These e.i.r.p. limits apply for stations with an antenna height above average terrain (HAAT) up to 305 metres.

Peak to Average Ratio: ≤13 dB

TEST REPORT**3.2 Measurement Procedure**

The EUT was configured to transmit on maximum power and proper modulation. The transmitter power shall be measured in terms of a root-mean-square (RMS) average value. In case of the EUT was configured to MIMO mode, since the EUT transmits on all antennas simultaneously in the same frequency range, using the Measure-and-Sum approach, the output power at all antennas were tested, and the total output power were then summed mathematically in linear power units according to FCC KDB 662911 D01.

A peak to average ratio measurement is performed at the conducted ports of the EUT for single carrier for single RAT mode. The spectrum analyzers Complementary Cumulative Distribution Function (CCDF) was used and 0.1% probability value recorded.

3.3 Measurement result

NR-1C

Antenna Port	NR Modulation	NR Carrier Bandwidth (MHz)	Output power / Peak-to-Average Ratio (PAR)								
			Channel position B			Channel position M			Channel position T		
			Power (dBm)	Power (dBm /MHz)	PAR (dB)	Power (dBm)	Power (dBm /MHz)	PAR (dB)	Power (dBm)	Power (dBm /MHz)	PAR (dB)
A	16QAM	25	47.60	34.26	7.33	47.63	34.36	7.44	47.69	34.47	7.71
B	16QAM	25	47.64	34.29	7.33	47.67	34.38	7.45	47.68	34.44	7.74
C	16QAM	25	47.67	34.34	7.32	47.69	34.42	7.44	47.68	34.50	7.71
D	16QAM	25	47.76	34.44	7.33	47.67	34.30	7.46	47.57	34.40	7.74
Total			53.69	40.35	-	53.69	40.39	-	53.68	40.47	-
Limit			-	62.15	13	-	62.15	13	-	62.15	13
Max antenna gain			-	21.80	-	-	21.76	-	-	21.68	-

Antenna Port	NR Modulation	NR Carrier Bandwidth (MHz)	Output power / Peak-to-Average Ratio (PAR)								
			Channel position B			Channel position M			Channel position T		
			Power (dBm)	Power (dBm /MHz)	PAR (dB)	Power (dBm)	Power (dBm /MHz)	PAR (dB)	Power (dBm)	Power (dBm /MHz)	PAR (dB)
A	16QAM	30	47.61	33.52	7.40	47.65	33.56	7.52	47.65	33.60	7.73
B	16QAM	30	47.66	33.58	7.43	47.65	33.55	7.57	47.65	33.59	7.77
C	16QAM	30	47.70	33.60	7.41	47.69	33.60	7.53	47.69	33.62	7.74
D	16QAM	30	47.67	33.56	7.43	47.61	33.59	7.57	47.60	33.55	7.80
Total			53.68	39.59	-	53.67	39.60	-	53.67	39.61	-
Limit			-	62.15	13	-	62.15	13	-	62.15	13
Max antenna gain			-	22.56	-	-	22.55	-	-	22.54	-

Antenna Port	NR Modulation	NR Carrier Bandwidth (MHz)	Output power / Peak-to-Average Ratio (PAR)								
			Channel position B			Channel position M			Channel position T		
			Power (dBm)	Power (dBm /MHz)	PAR (dB)	Power (dBm)	Power (dBm /MHz)	PAR (dB)	Power (dBm)	Power (dBm /MHz)	PAR (dB)
A	16QAM	35	-	-	-	47.62	32.84	7.71	-	-	-
B	16QAM	35	-	-	-	47.67	32.90	7.75	-	-	-
C	16QAM	35	-	-	-	47.68	32.91	7.72	-	-	-
D	16QAM	35	-	-	-	47.64	32.85	7.76	-	-	-
Total			-	-	-	53.67	38.90	-	-	-	-
Limit			-	-	-	-	62.15	13	-	-	-
Max antenna gain			-	-	-	-	23.25	-	-	-	-

NR 25MHz, Channel B, Power

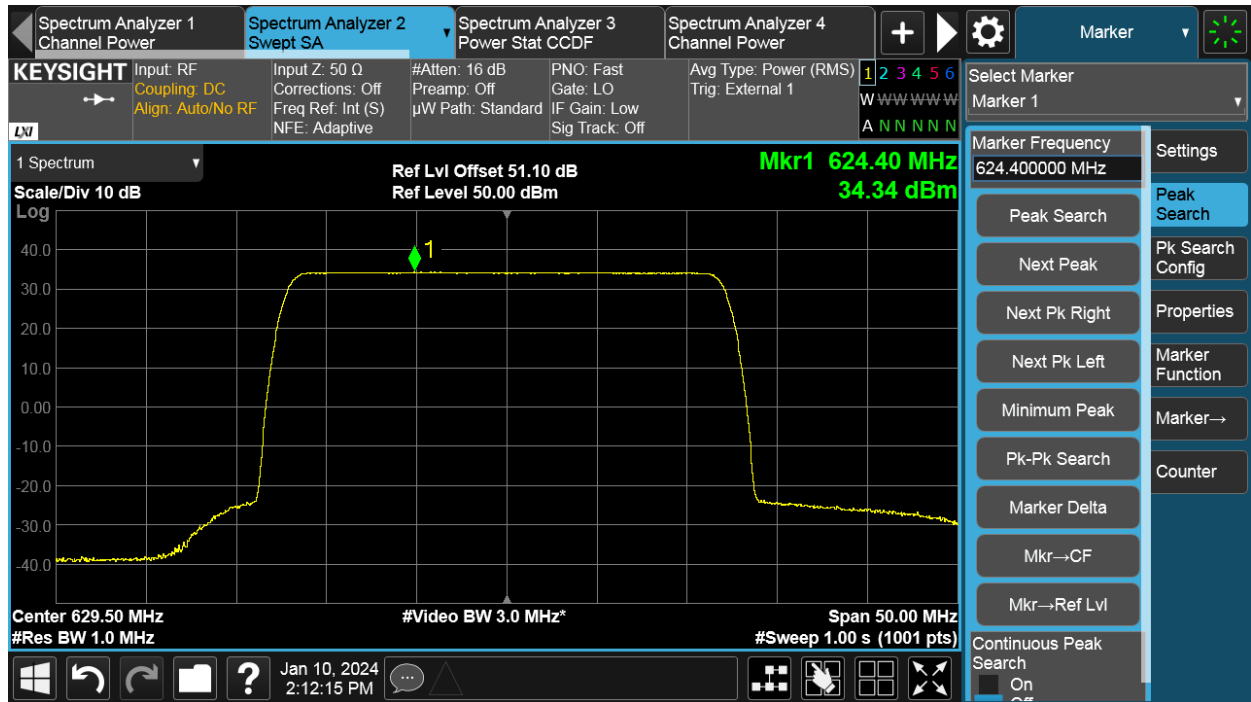

NR 25MHz, Channel B, PAR

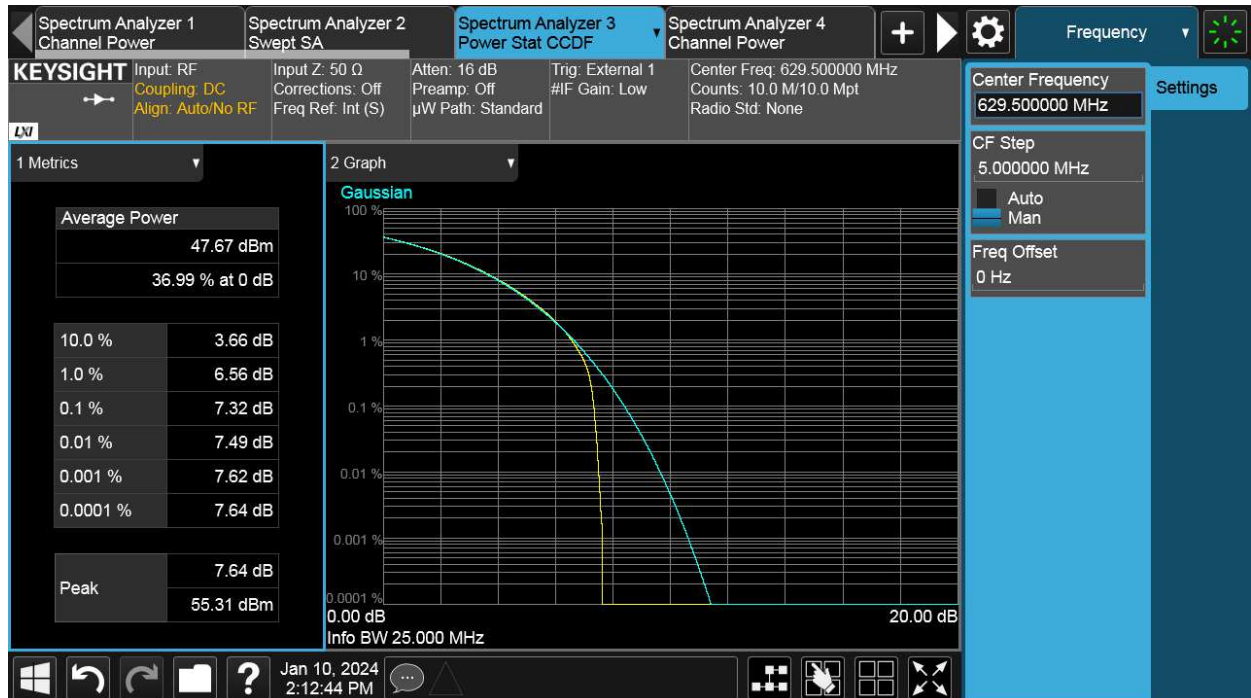

NR 25MHz, Channel M, Power

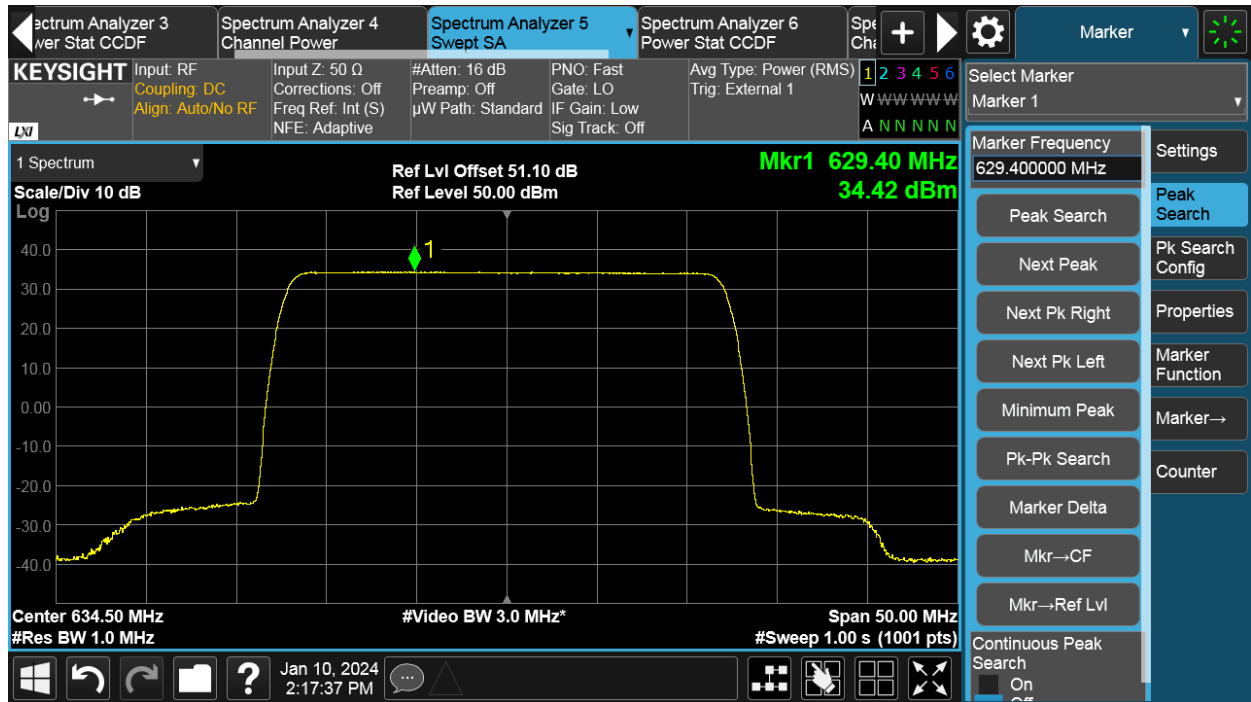

NR 25MHz, Channel M, PAR



NR 25MHz, Channel T, Power

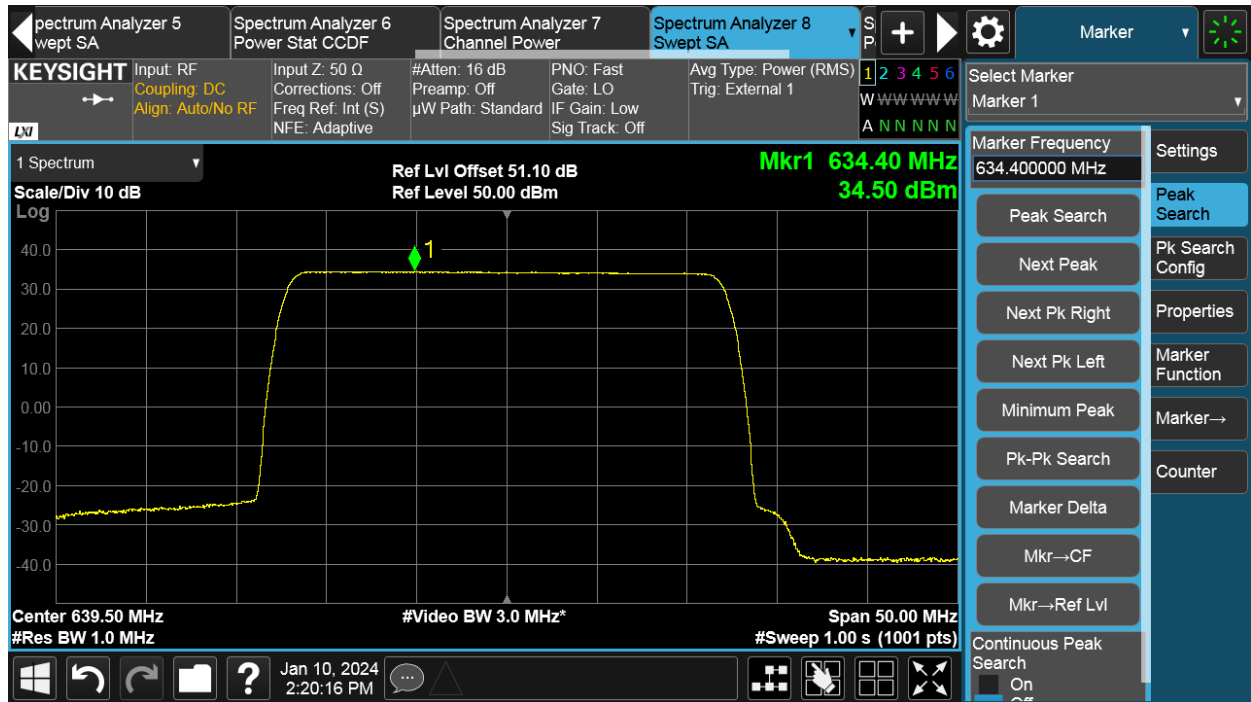

NR 25MHz, Channel T, PAR



NR 30MHz, Channel B, Power

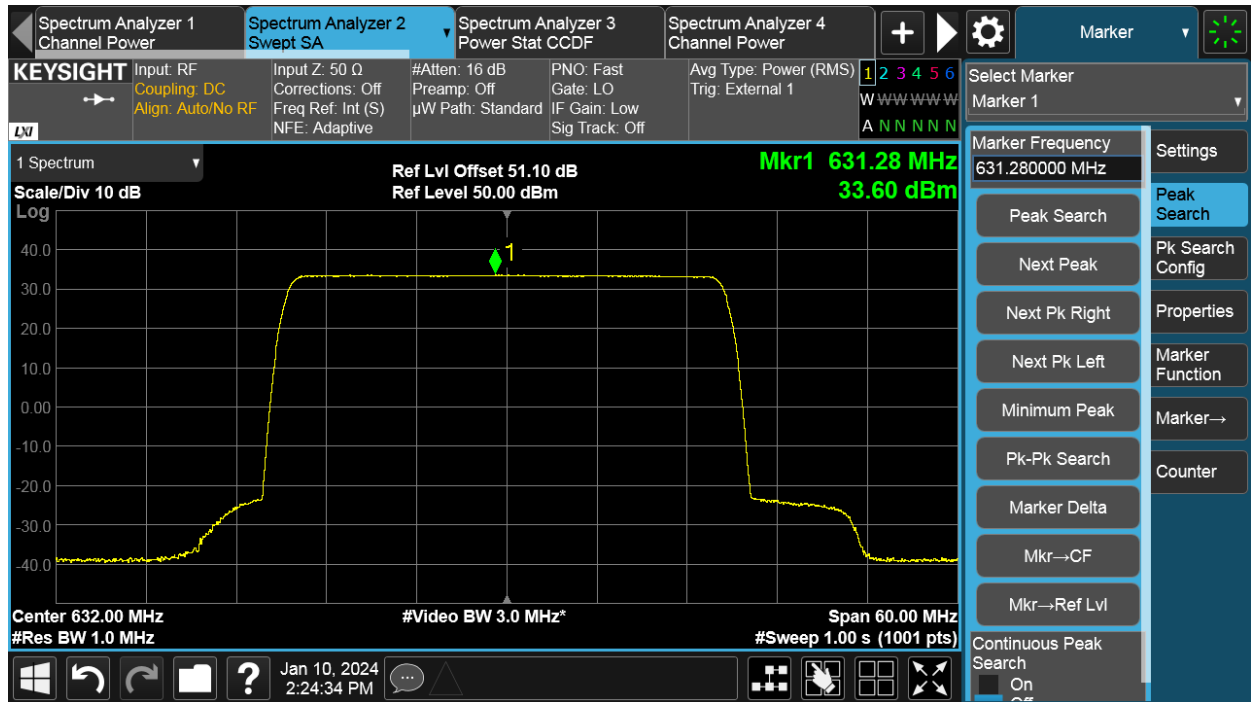

NR 30MHz, Channel B, PAR

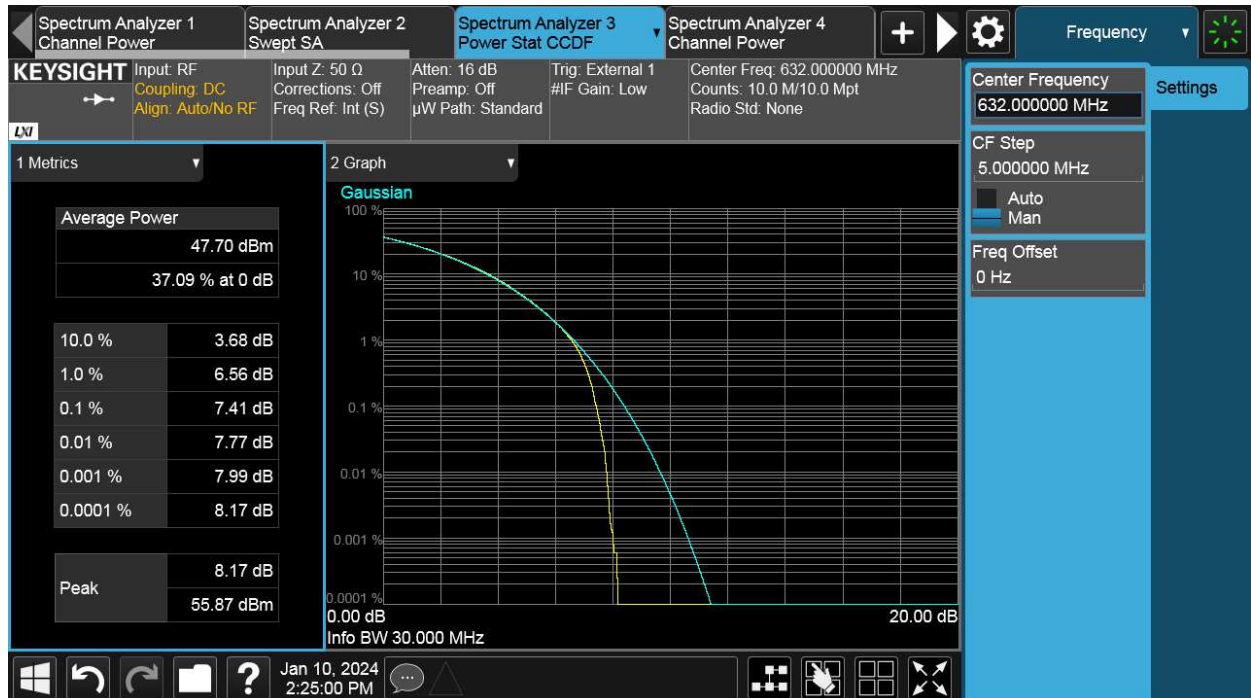

NR 30MHz, Channel M, Power

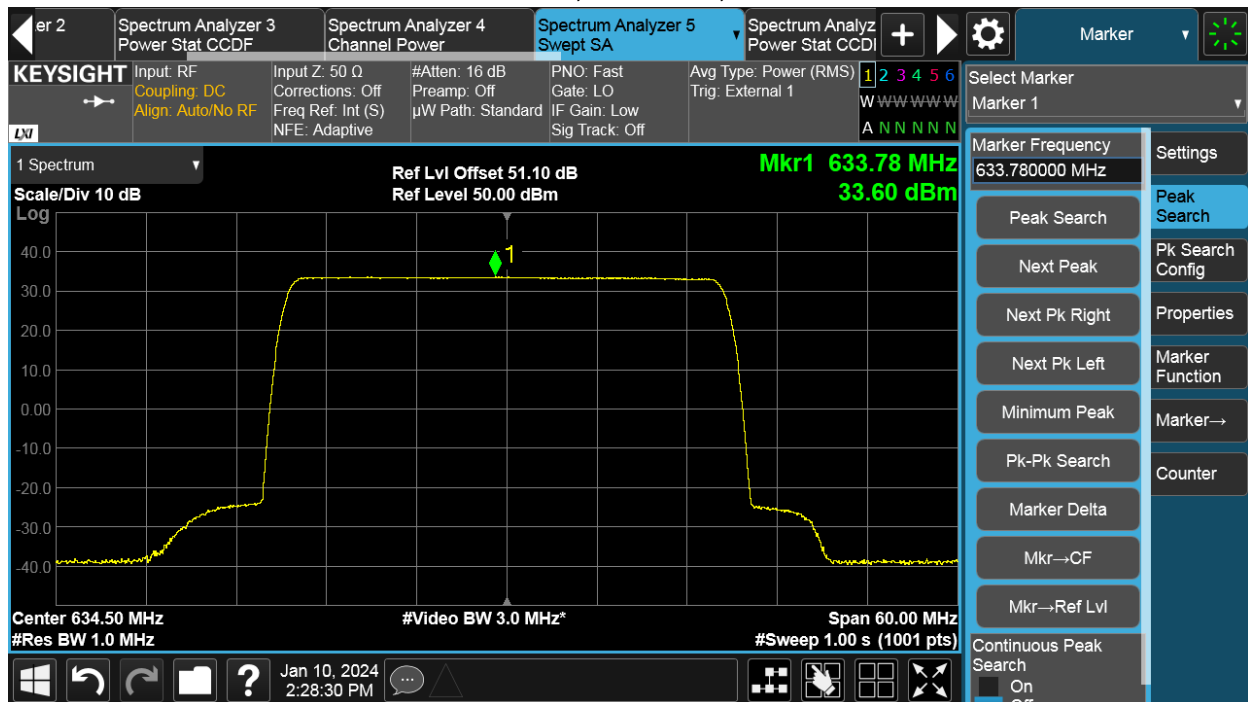

NR 30MHz, Channel M, PAR



NR 30MHz, Channel T, Power

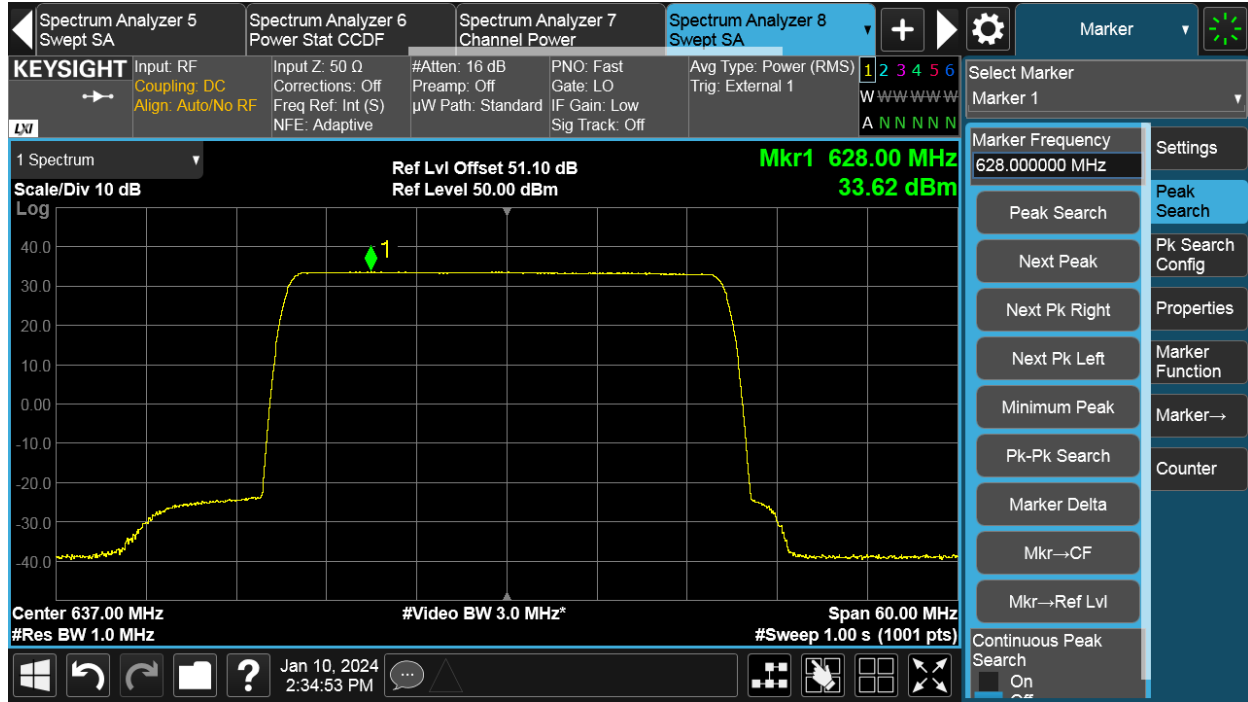

NR 30MHz, Channel T, PAR

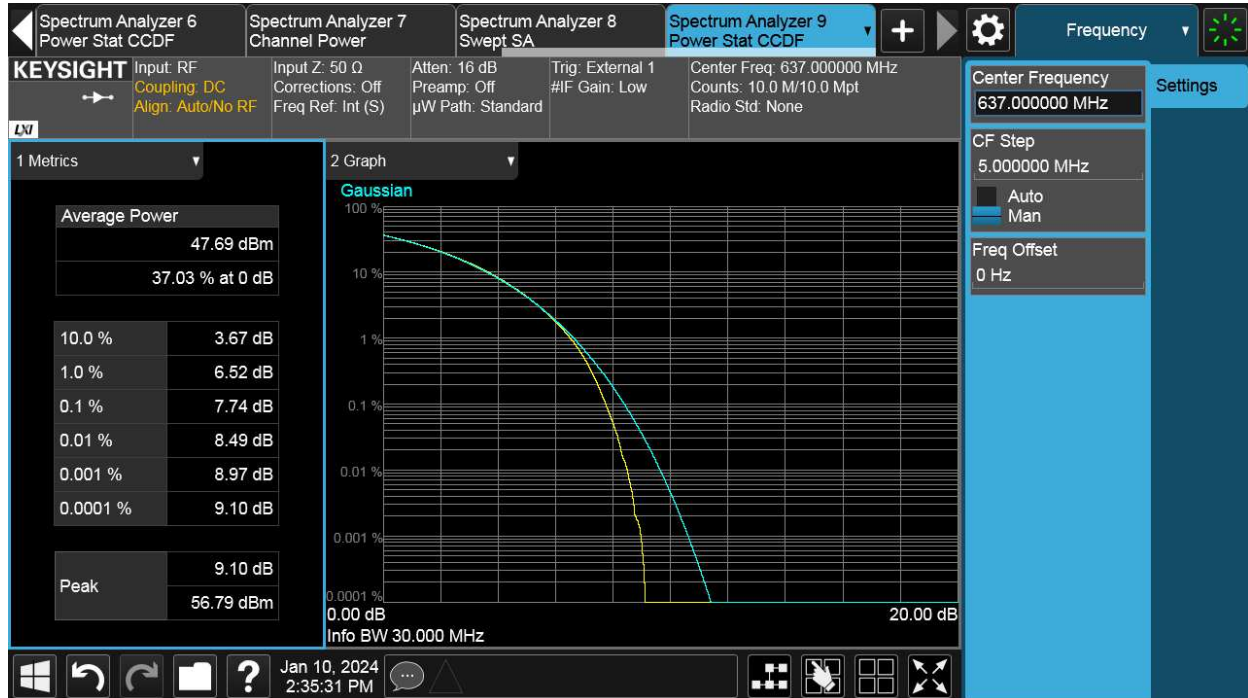

NR 35MHz, Channel M, Power

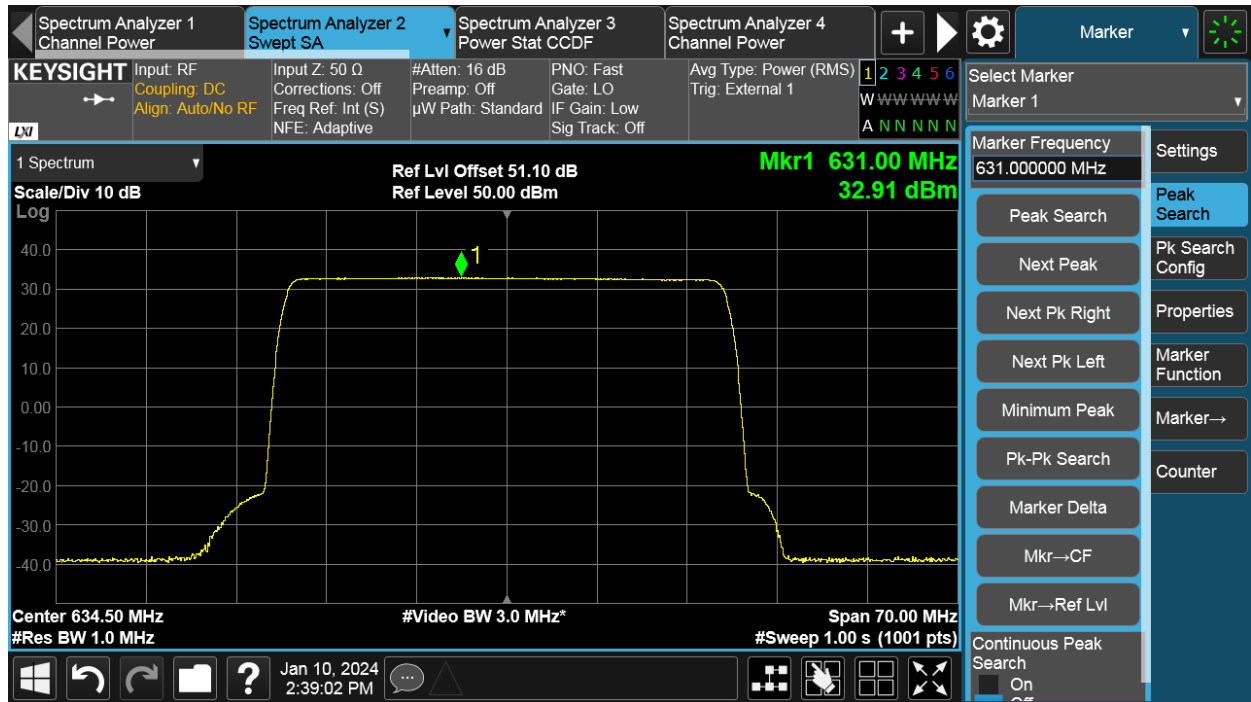

NR 35MHz, Channel M, PAR

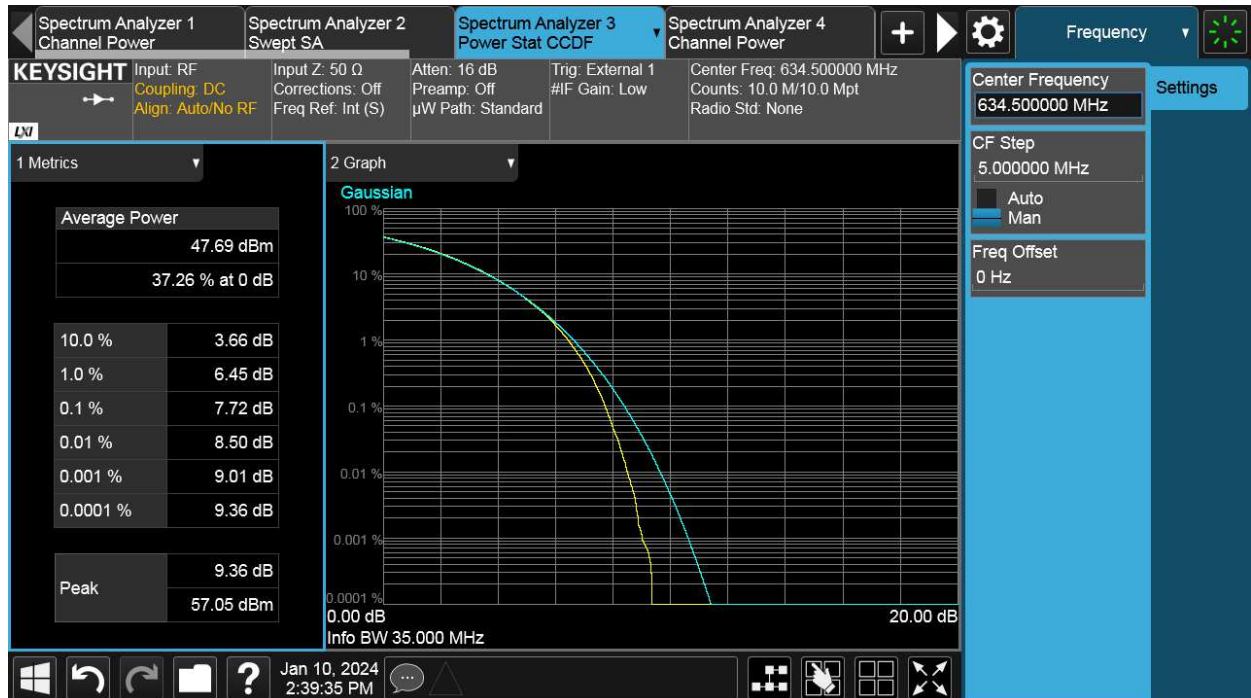

TEST REPORT**4 Occupied Bandwidth****Test result: Pass****4.1 Measurement Procedure**

The EUT was set to transmit at maximum power and testing was carried out on bottom, middle and top channels. Using the Occupied Bandwidth measurement function in the spectrum analyzer, the 26dB bandwidth was measured in accordance with FCC KDB 971168 D01 Clause 4.2.

The measurement method is from KDB 971168 4.2:

- a) The spectrum analyzer center frequency is set to the nominal EUT channel center frequency. The frequency span for the spectrum analyzer shall be set wide enough to capture all modulation products including the emission skirts (i.e., two to five times the OBW).
- b) The nominal IF filter bandwidth (3 dB RBW) shall be in the range of 1 to 5 % of the anticipated OBW, and the VBW shall be at least 3 times the RBW.
- c) Set the reference level of the instrument as required to keep the signal from exceeding the maximum input mixer level for linear operation. In general, the peak of the spectral envelope must be at least $10\log(\text{OBW} / \text{RBW})$ below the reference level.
- d) Set the detection mode to peak, and the trace mode to max hold.
- e) Use the 99 % power bandwidth function of the spectrum analyzer and report the measured bandwidth.

TEST REPORT

4.2 Measurement result

NR-1C

99% Occupied Bandwidth

Antenna Port	Modulation	Bandwidth	Occupied Bandwidth (MHz)		
			Channel Position B	Channel Position M	Channel Position T
C	16QAM	25MHz	23.718	23.720	23.716
C	16QAM	30MHz	28.540	28.543	28.540
C	16QAM	35MHz	-	33.561	-

-26dBc Occupied Bandwidth

Antenna Port	Modulation	Bandwidth	Occupied Bandwidth (MHz)		
			Channel Position B	Channel Position M	Channel Position T
C	16QAM	25MHz	24.79	24.80	24.80
C	16QAM	30MHz	29.56	29.56	29.57
C	16QAM	35MHz	-	34.71	-

16QAM, 25MHz, Channel position B

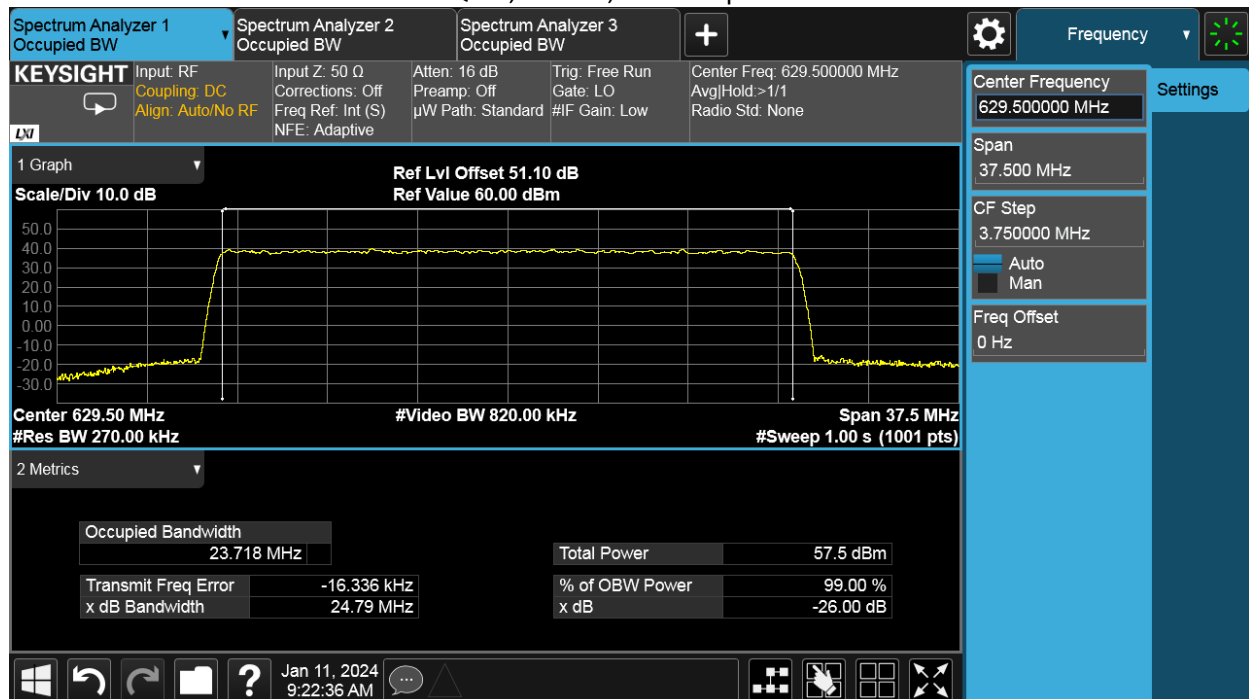

16QAM, 25MHz, Channel position M

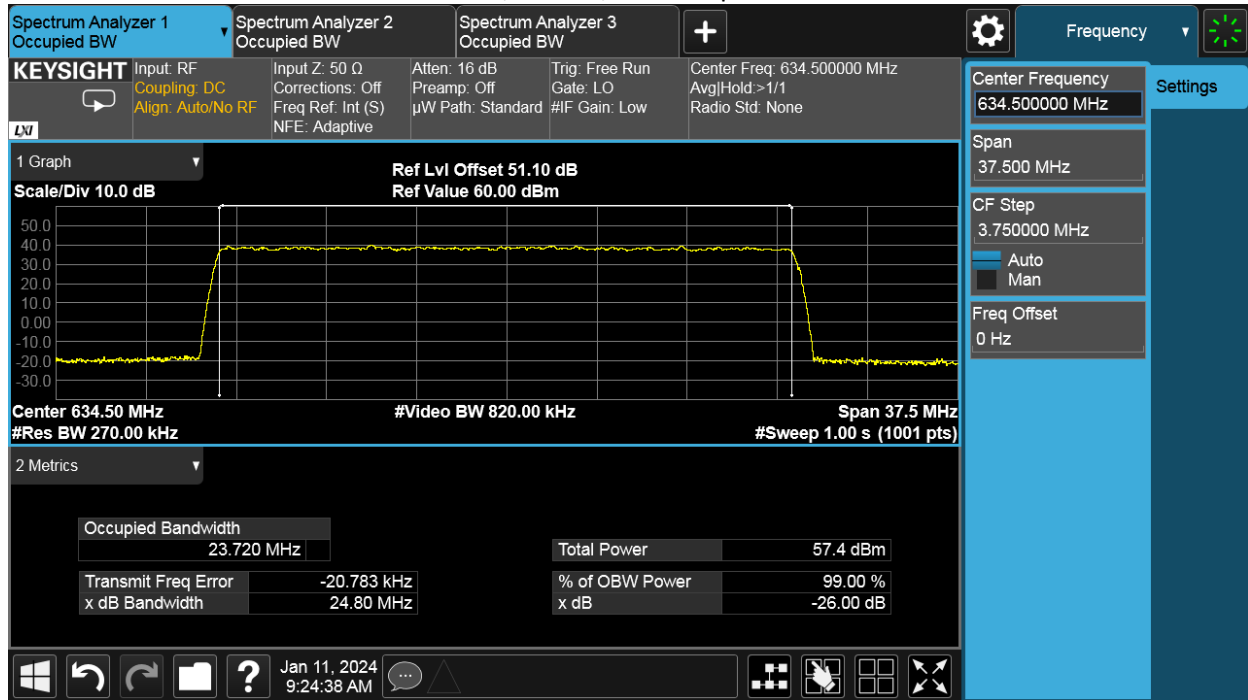

16QAM, 25MHz, Channel position T

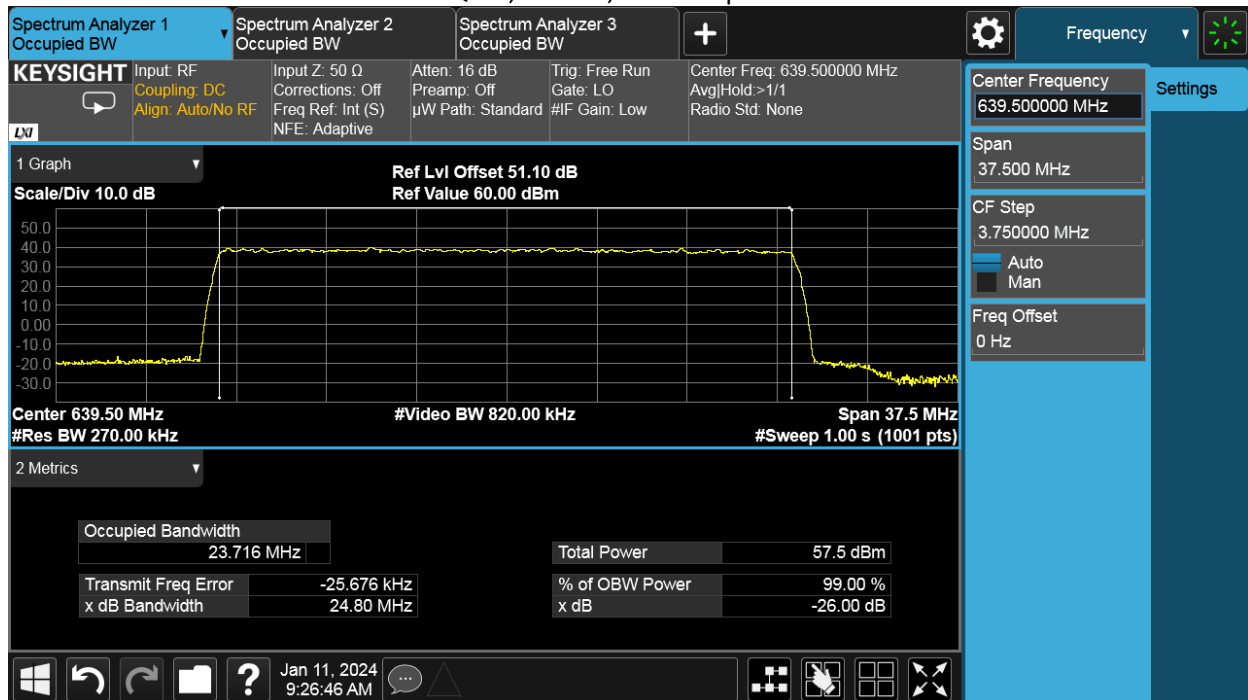

16QAM, 30MHz, Channel position B

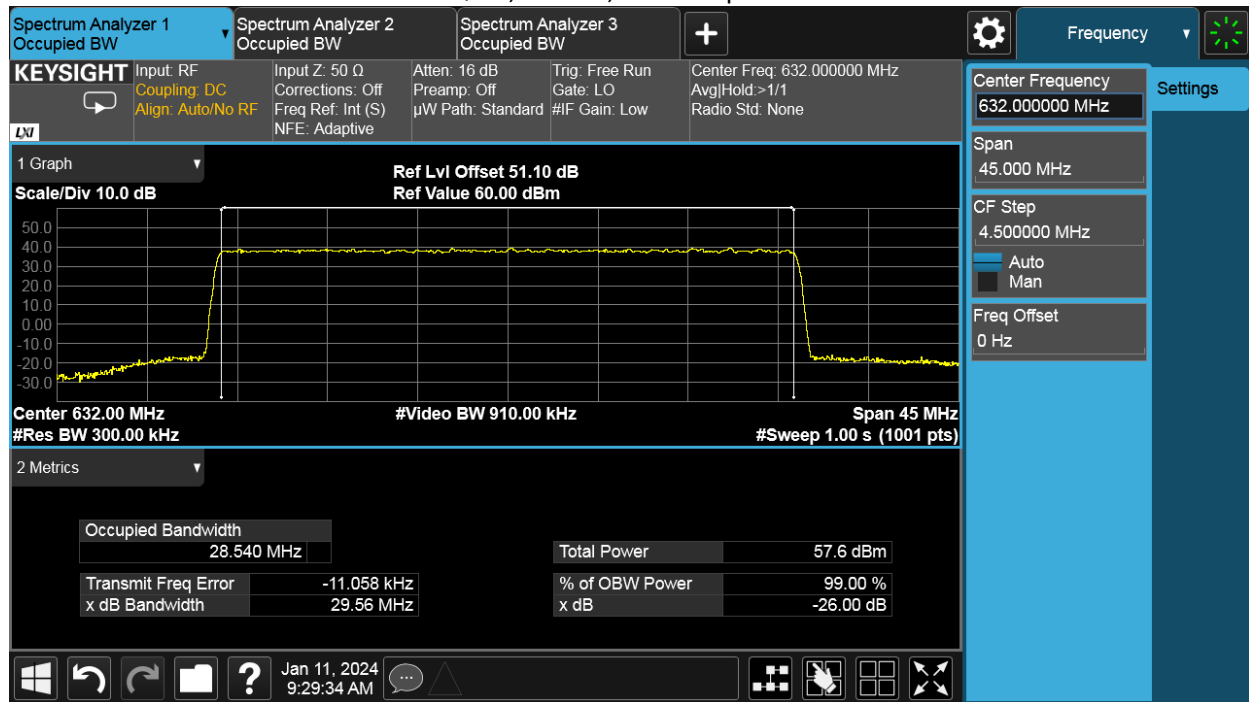

16QAM, 30MHz, Channel position M

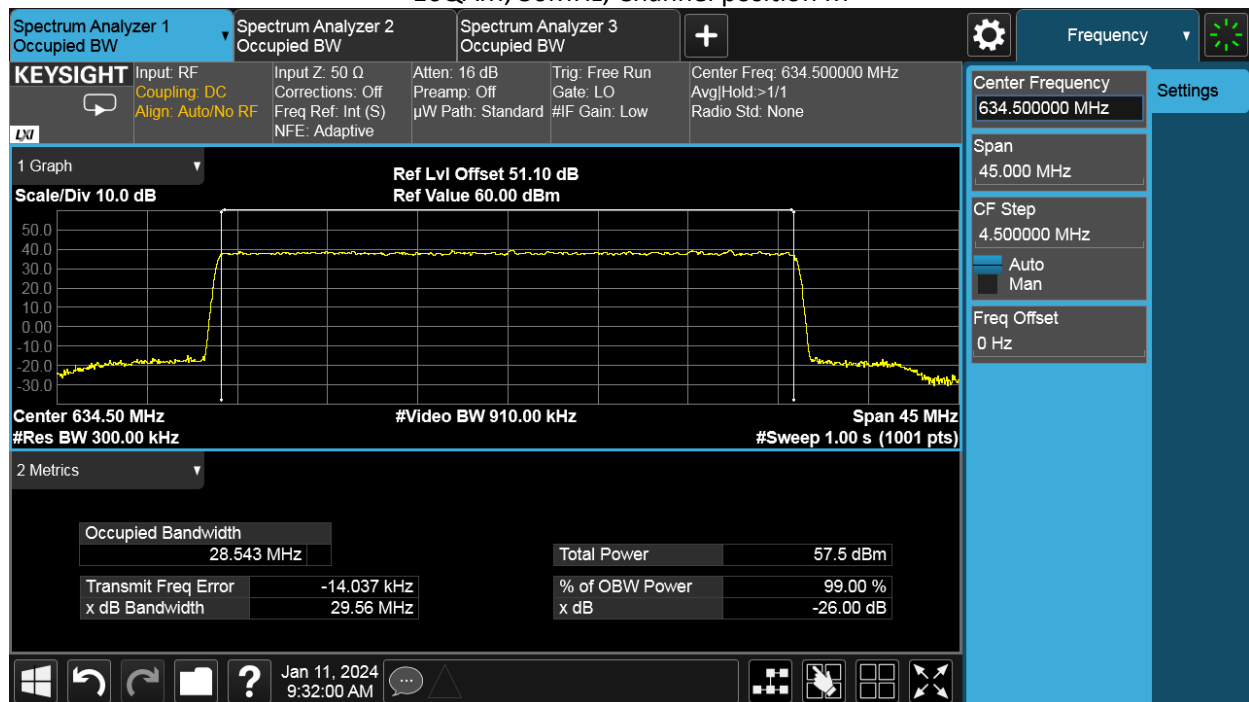

16QAM, 30MHz, Channel position T

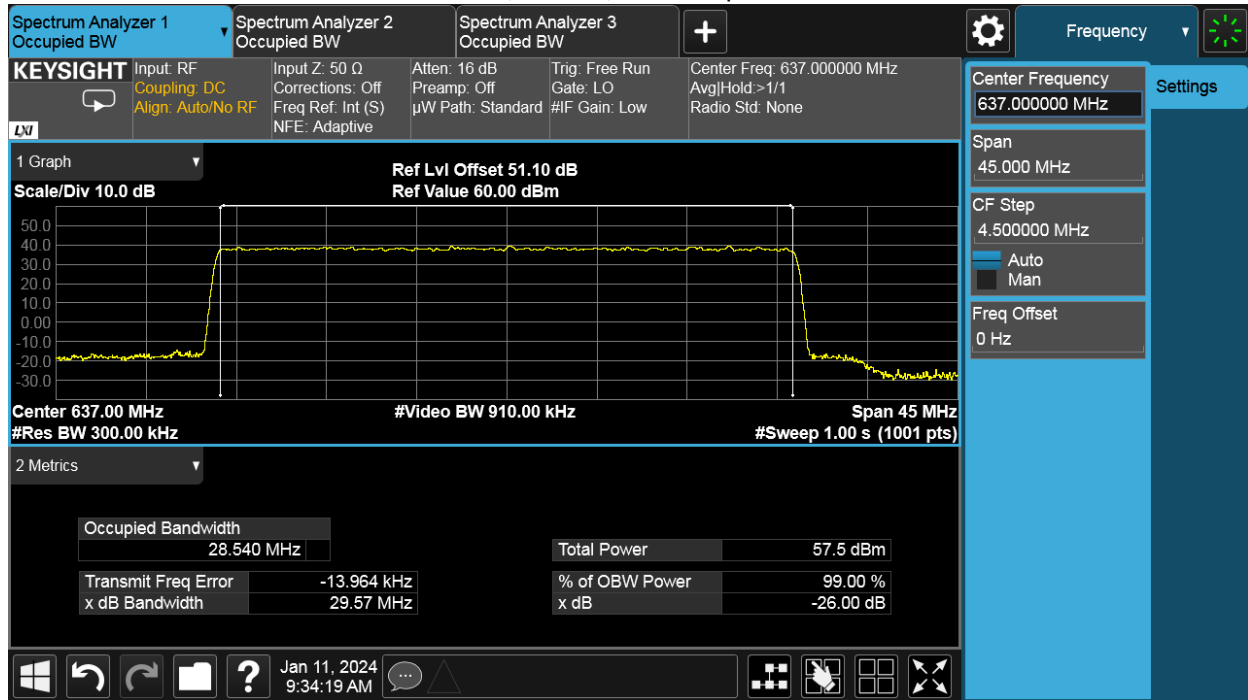

16QAM, 35MHz, Channel position M

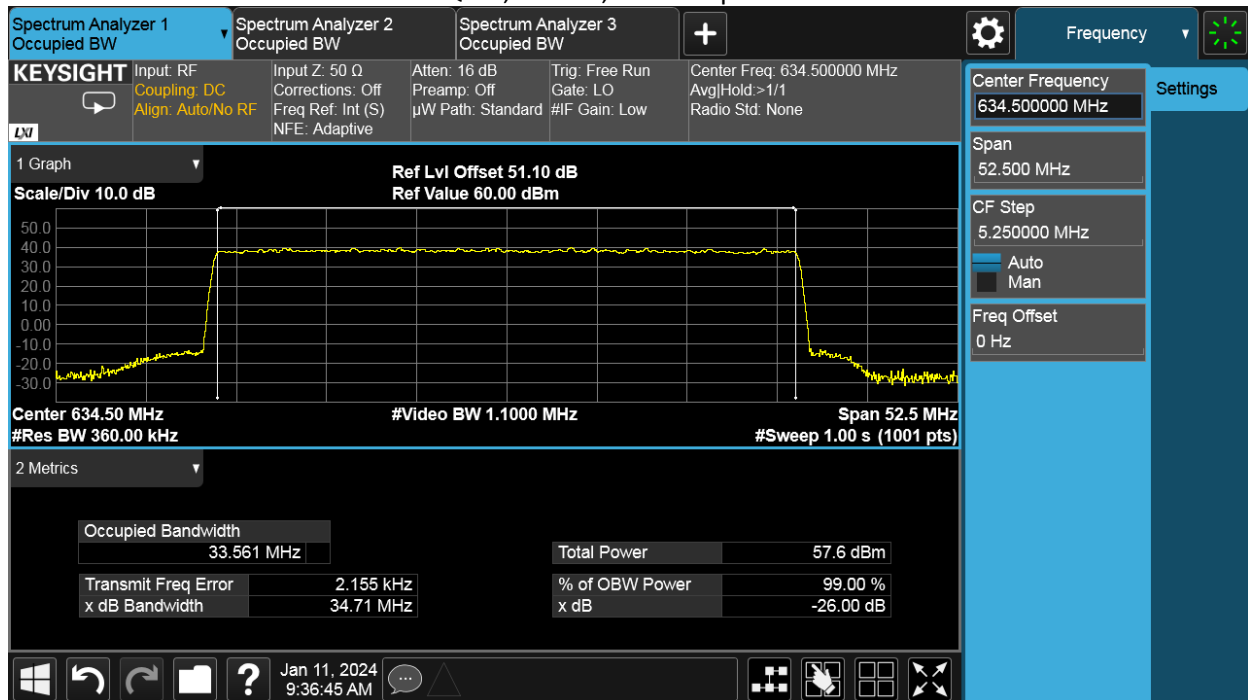

5 Unwanted Emissions at Band Edge

Test result: Pass

5.1 Limit

The unwanted emissions in any 100 kHz bandwidth on any frequency outside the low frequency edge and the high frequency edge of each frequency block range(s), shall be attenuated below the transmitter power, P (dBW), by at least $43 + 10 \log_{10} p$ (watts), dB. However, in the 100 kHz band immediately outside of the equipment's frequency block range, a resolution bandwidth of 30 kHz may be employed.

5.2 Measurement Procedure

The power of any emission outside of the authorized operating frequency ranges must be attenuated below the transmitting power (P) by a factor of at least $43 + 10 \log(P)$ dB.

For MIMO mode configurations, the limit was adjusted with a correction of -6.02dB [$10 \log(1/4)$] by using the Measure and Add $10 \log(N)$ dB technique according to KDB 662911 D01 Multiple Transmitter Output accounting for simultaneous transmission from antenna ports . Then the limit was adjusted to -19.02dBm.

Spectrum analyzer detector was set as RMS.

5.3 Measurement result

NR-1C-BE

Antenna Port	Channel Position	Modulation	Carrier Bandwidth (MHz)	RBW (kHz)	Limit (dBm)
C	B	16QAM	25	30	-19.02
C	T	16QAM	25	30	-19.02

Channel Position B

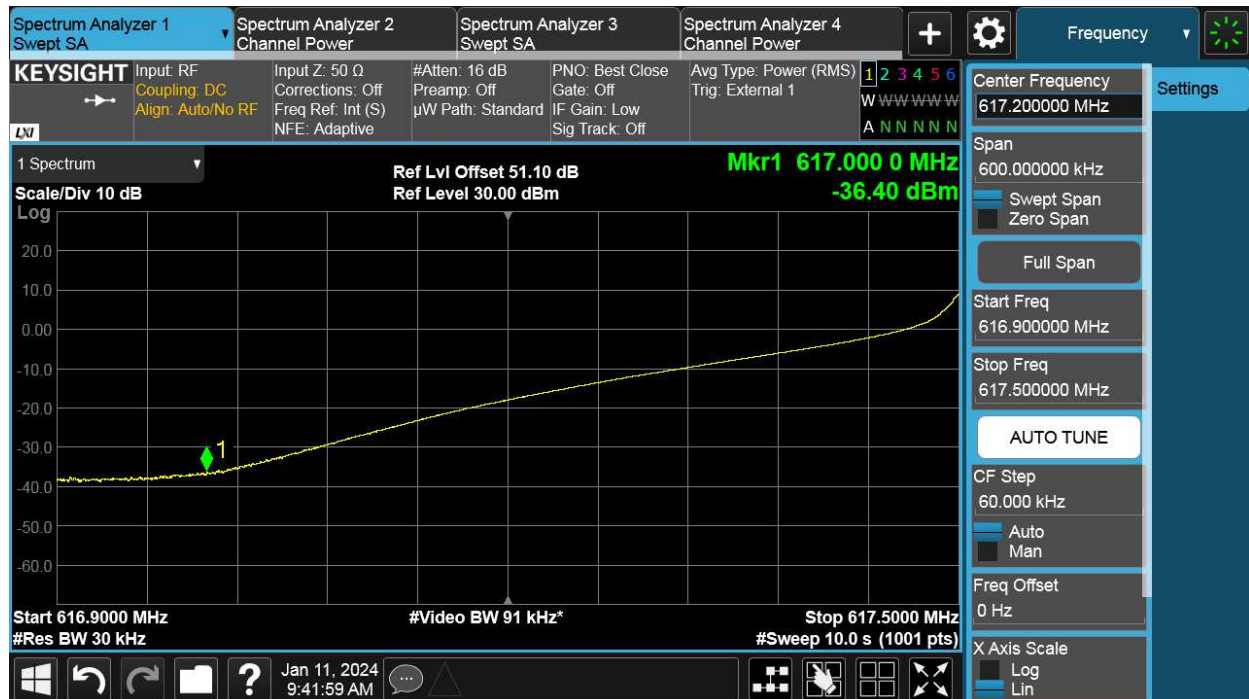

Channel Position T



Antenna Port	Channel Position	Modulation	Carrier Bandwidth (MHz)	RBW (kHz)	Limit (dBm)
C	B	16QAM	30	30	-19.02
C	T	16QAM	30	30	-19.02

Channel Position B

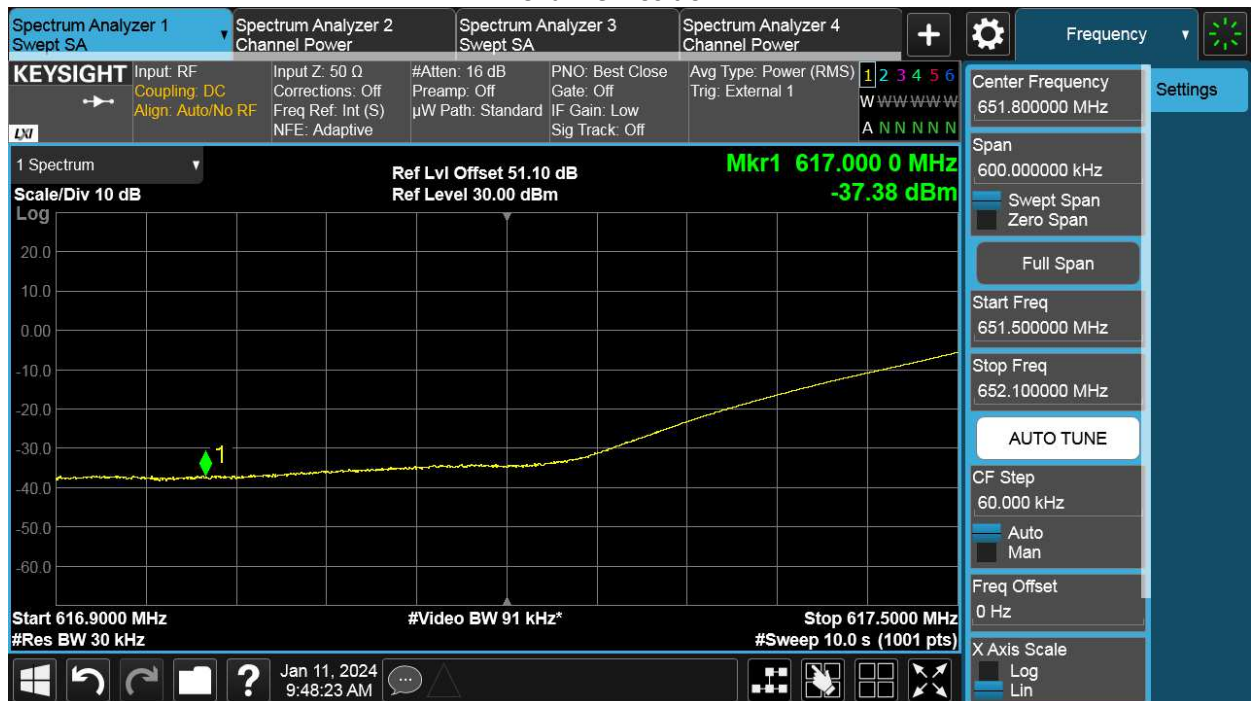

Channel Position T

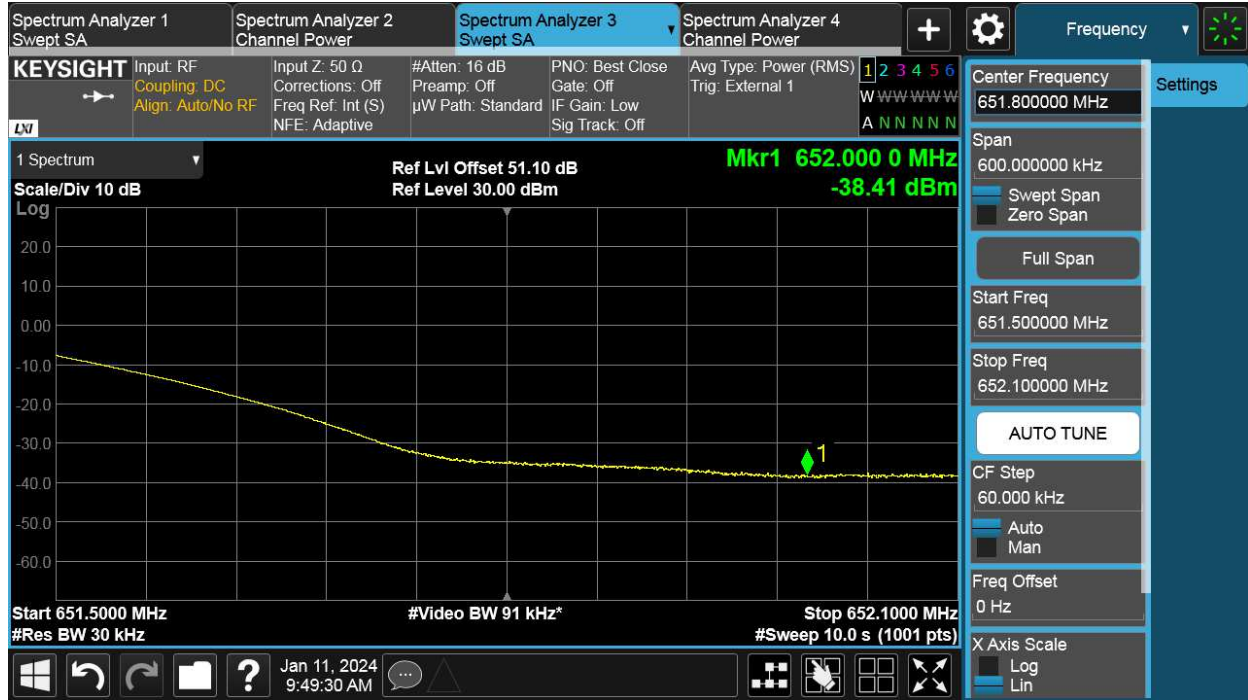

Antenna Port	Channel Position	Modulation	Carrier Bandwidth (MHz)	RBW (kHz)	Limit (dBm)
C	M	16QAM	35	30	-19.02

Channel Position M

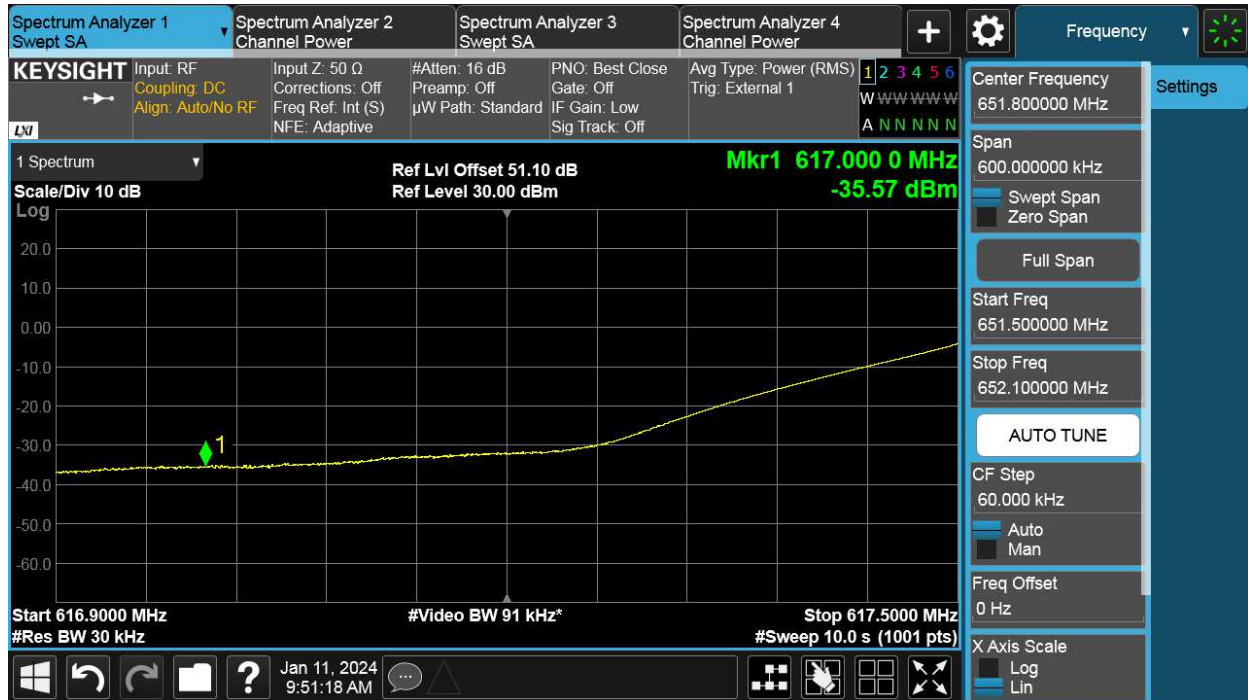

TEST REPORT



TEST REPORT

6 Conducted Unwanted Emission

Test result: Pass

6.1 Limit

The unwanted emissions in any 100 kHz bandwidth on any frequency outside the low frequency edge and the high frequency edge of each frequency block range(s), shall be attenuated below the transmitter power, P (dBW), by at least $43 + 10 \log_{10} p$ (watts), dB. However, in the 100 kHz band immediately outside of the equipment's frequency block range, a resolution bandwidth of 30 kHz may be employed.

6.2 Measurement Procedure

In accordance with FCC rules, the power of any emission outside of the authorized operating frequency ranges must be attenuated below the transmitting power (P) by a factor of at least $43 + 10 \log(P)$ dB.

The spurious emissions from the antenna terminal were measured. The transmitter output power was attenuated using an attenuator and the frequency spectrum investigated from 9kHz to 7GHz. The resolution bandwidth of 100kHz was employed for frequency band 9kHz to 1GHz. The resolution bandwidth of 1MHz was employed for frequency band 1GHz to 7GHz. The spectrum analyzer detector was set to RMS.

For MIMO mode configurations, the limit was adjusted with a correction of -6.02dB [$10\log(1/4)$] by using the Measure and Add $10\log(N)$ dB technique according to KDB 662911 D01 Multiple Transmitter Output accounting for simultaneous transmission from antenna ports. Then the limit was adjusted to -19.02dBm.

TEST REPORT

6.3 Measurement result

NR-1C

Antenna Port	Channel Position	NR Modulation	NR Channel BW (MHz)	Limit (dBm)
C	B	16QAM	25	-19.02
C	M	16QAM	25	-19.02
C	T	16QAM	25	-19.02

Channel Position B

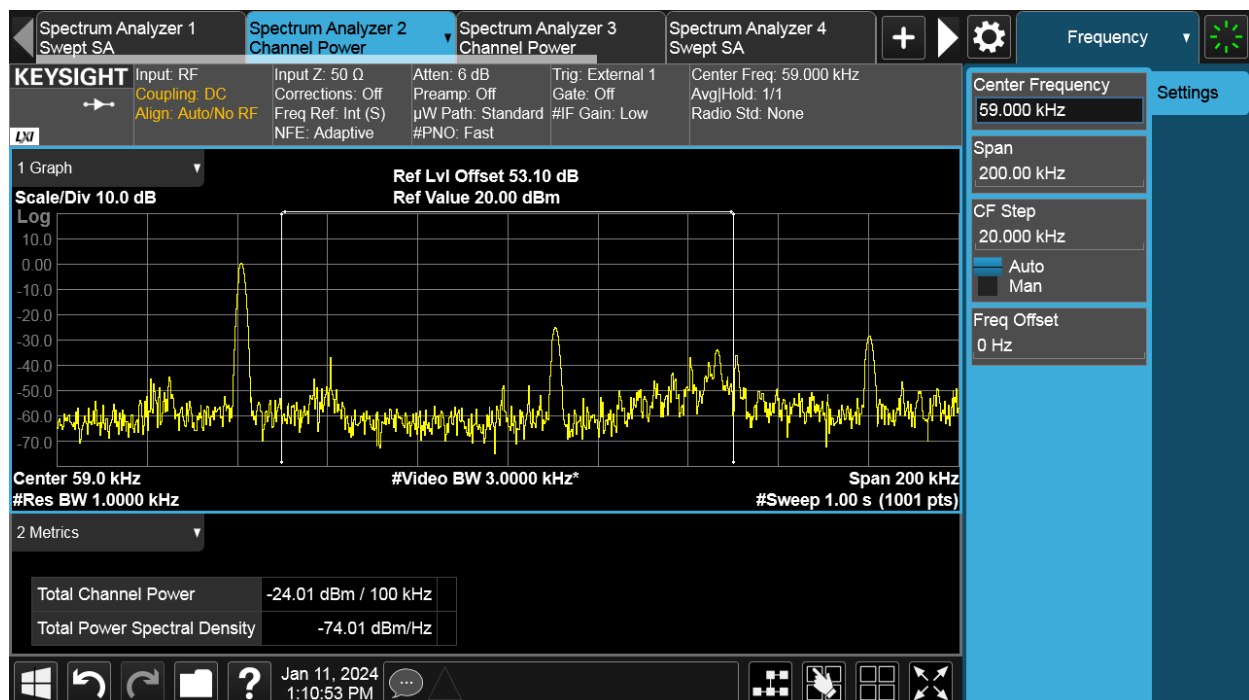
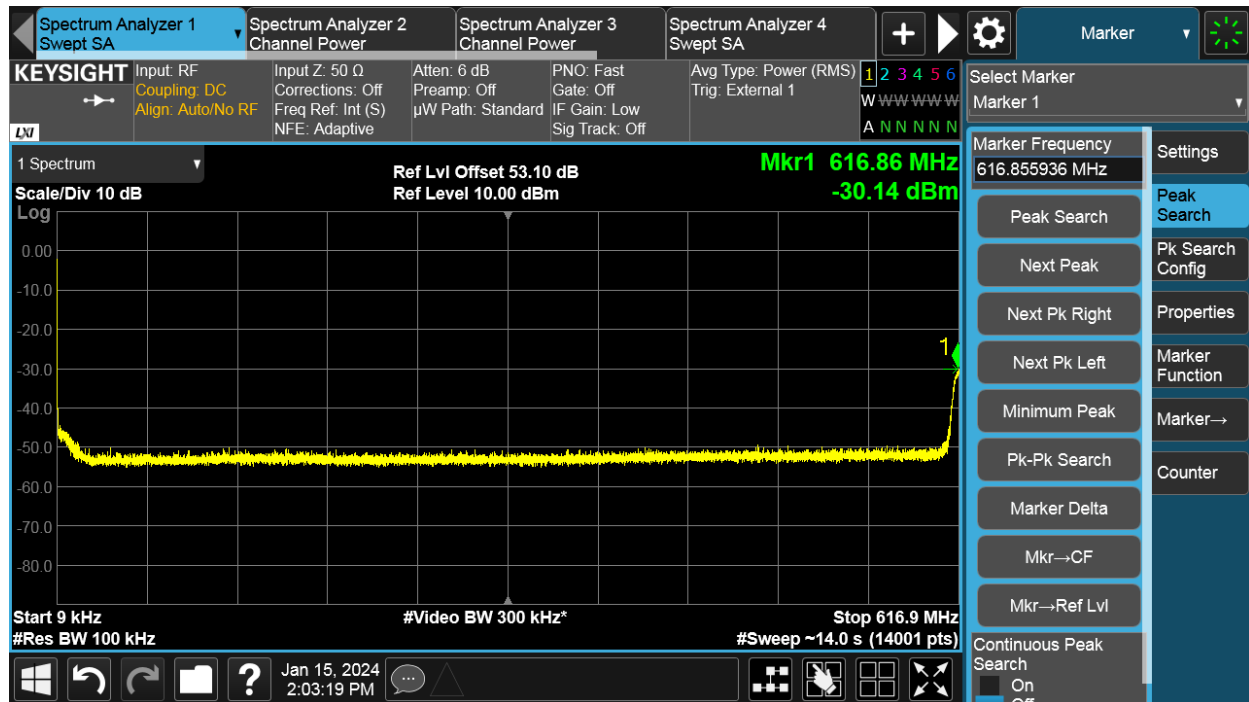

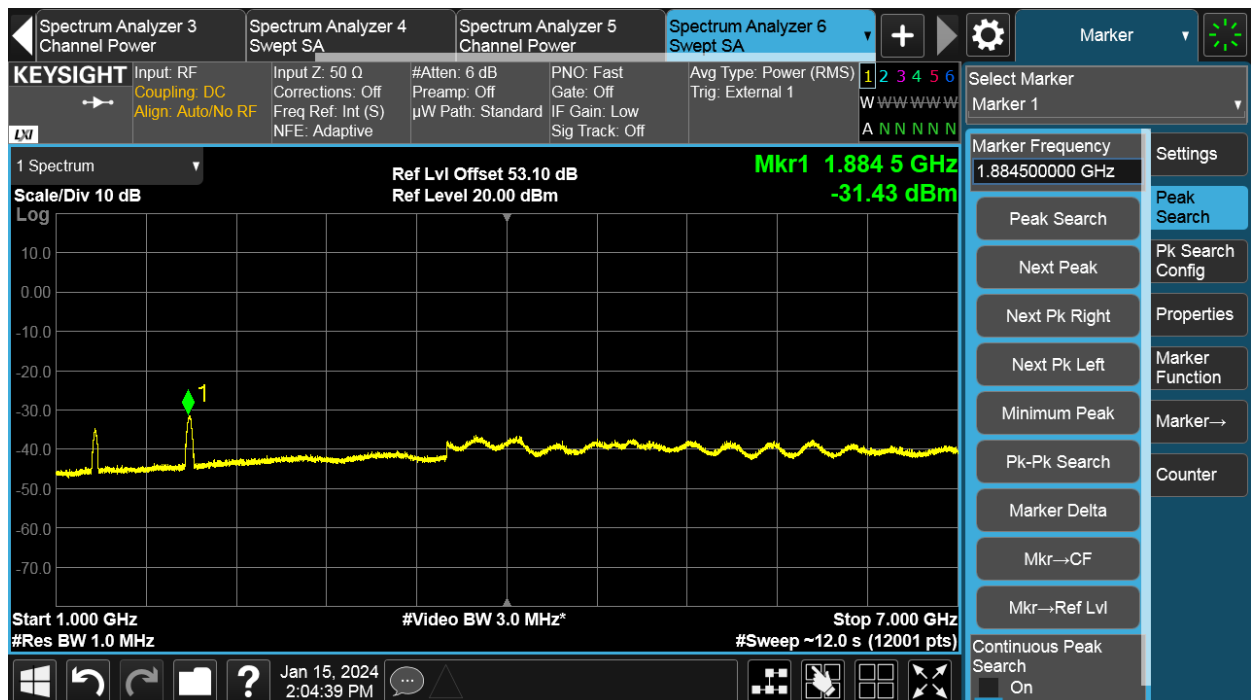
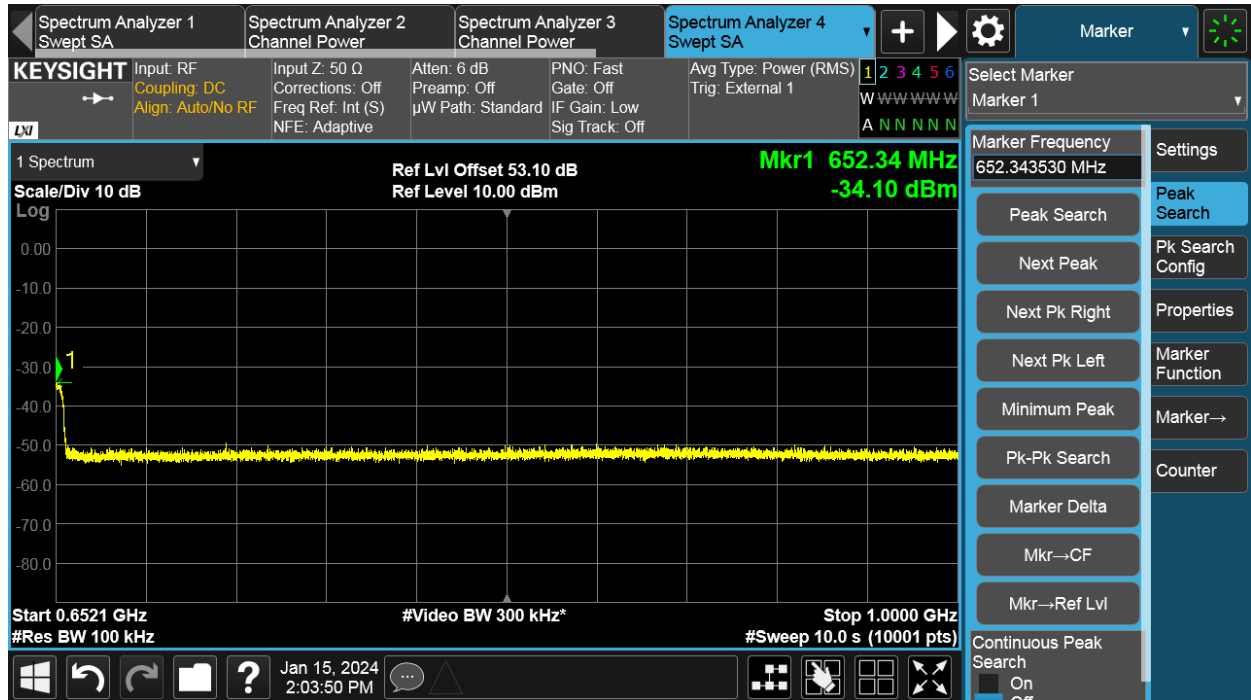

Channel Position M

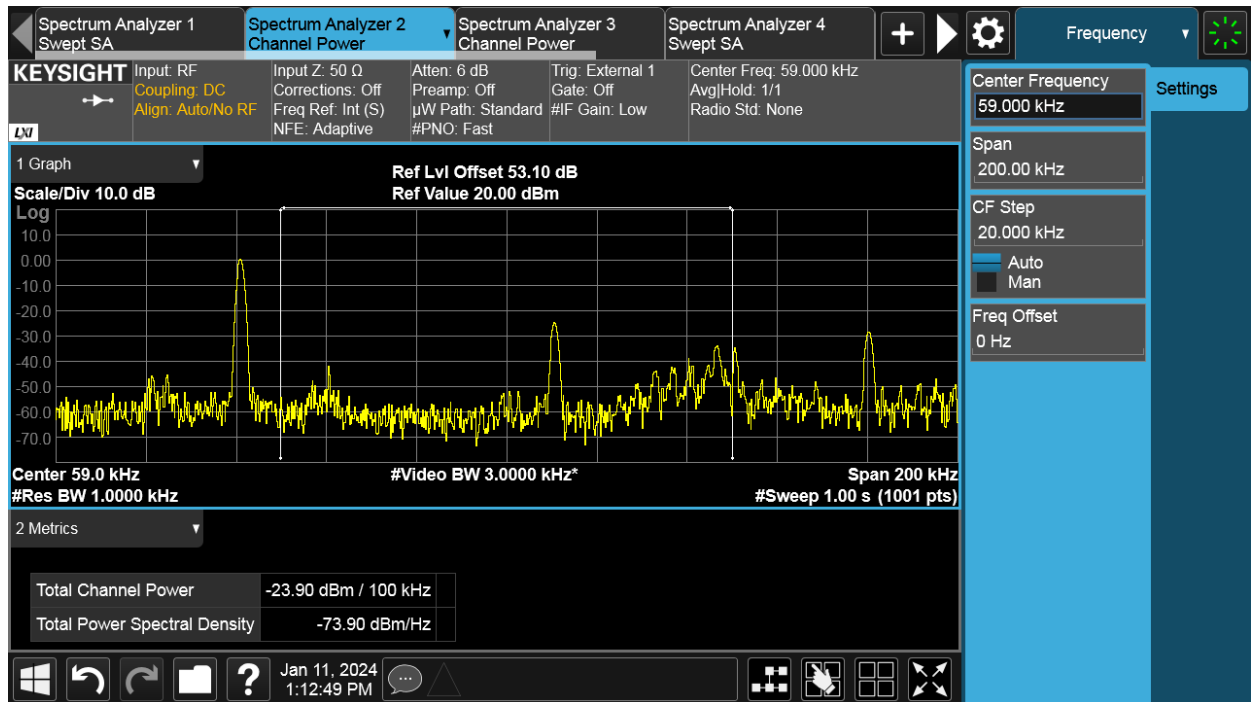
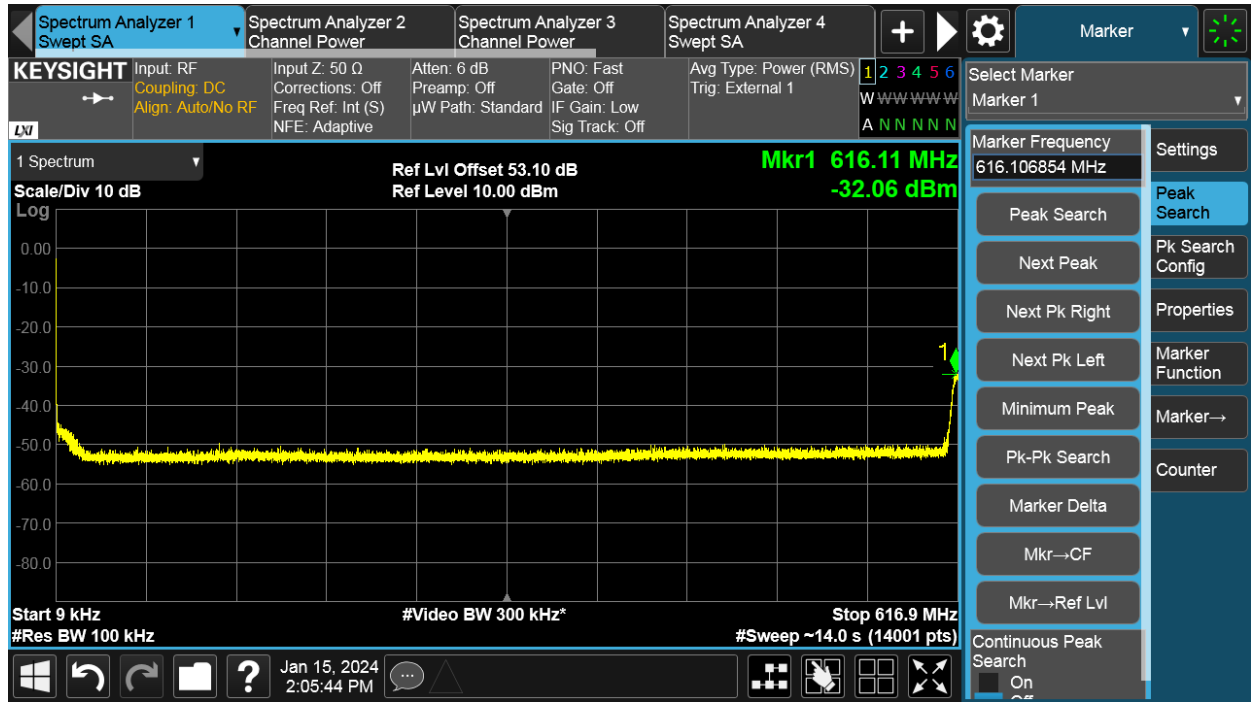

TEST REPORT

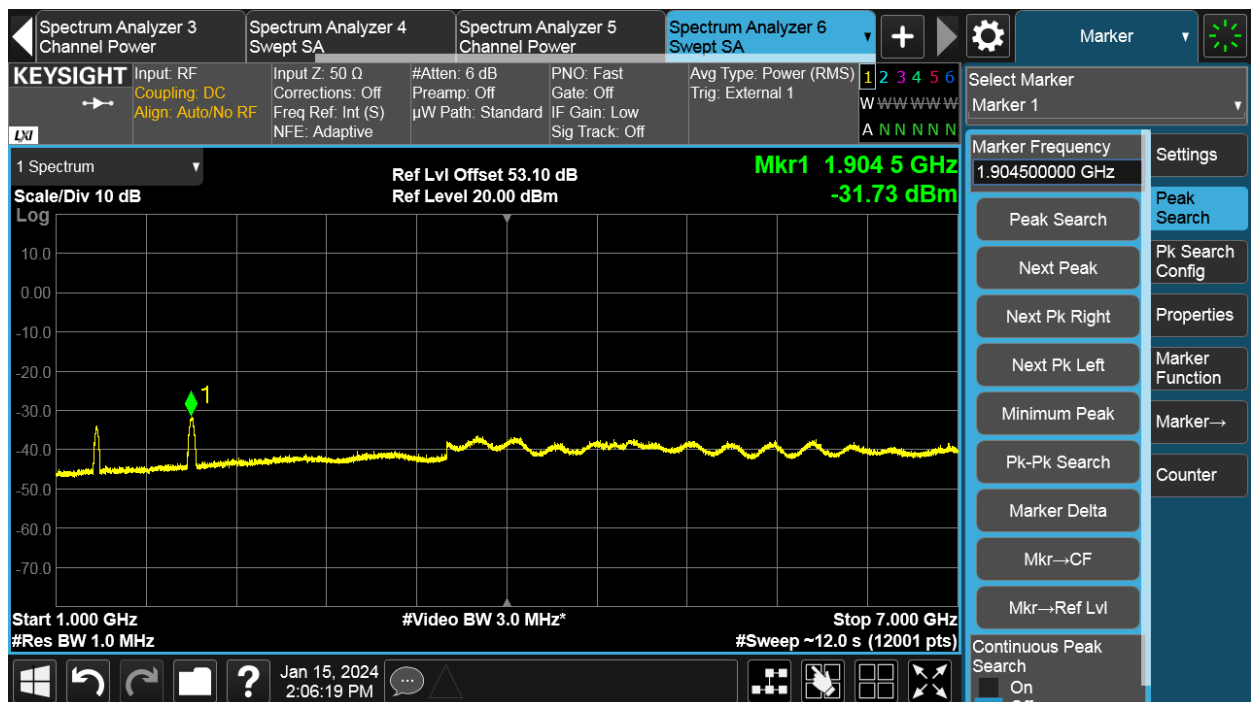
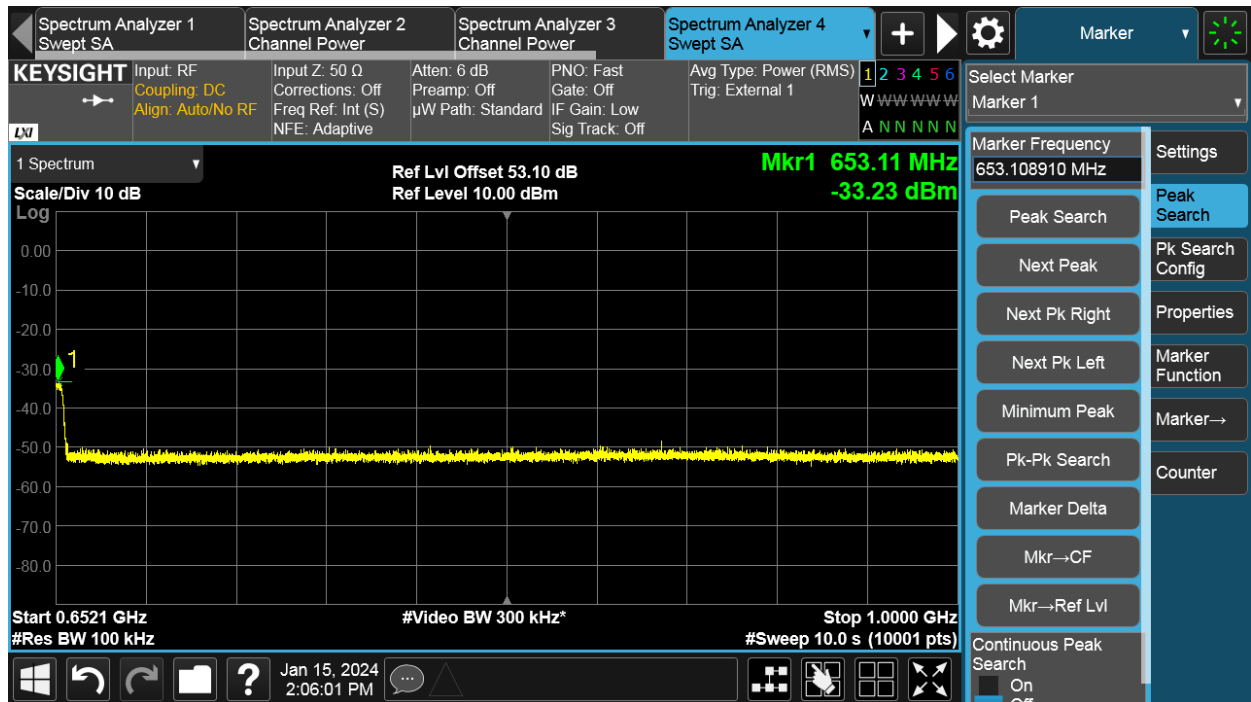

Channel Position T

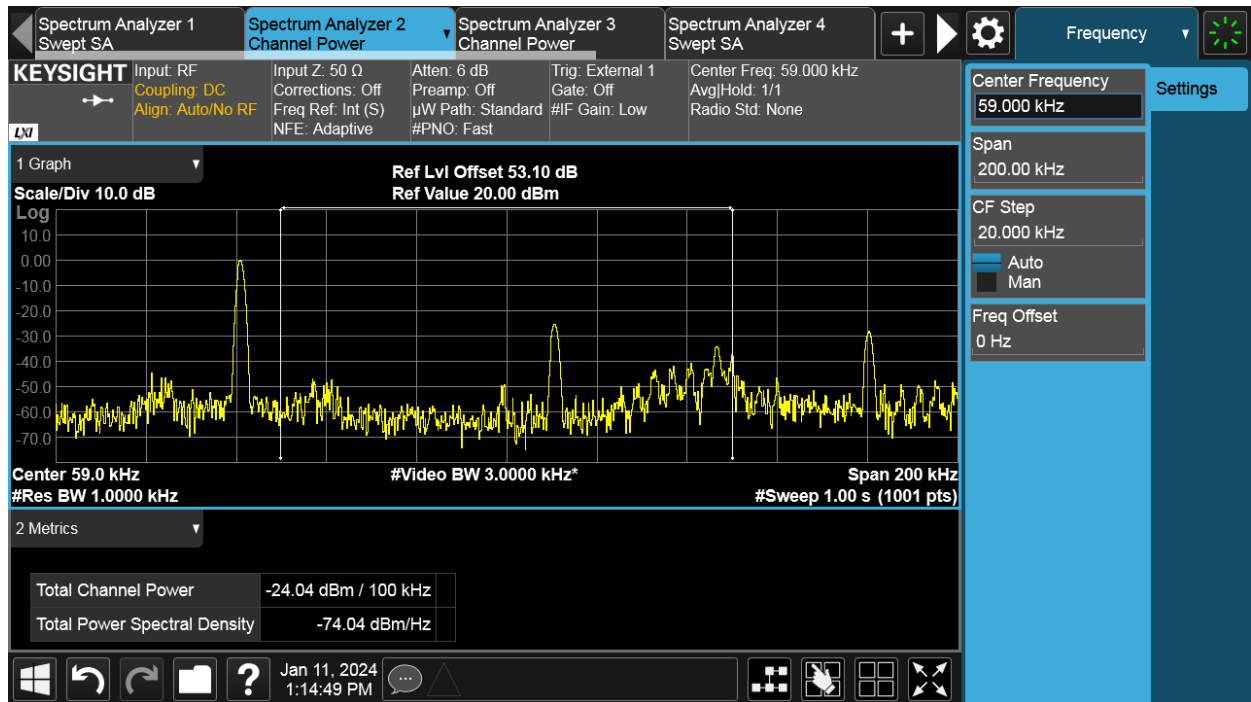
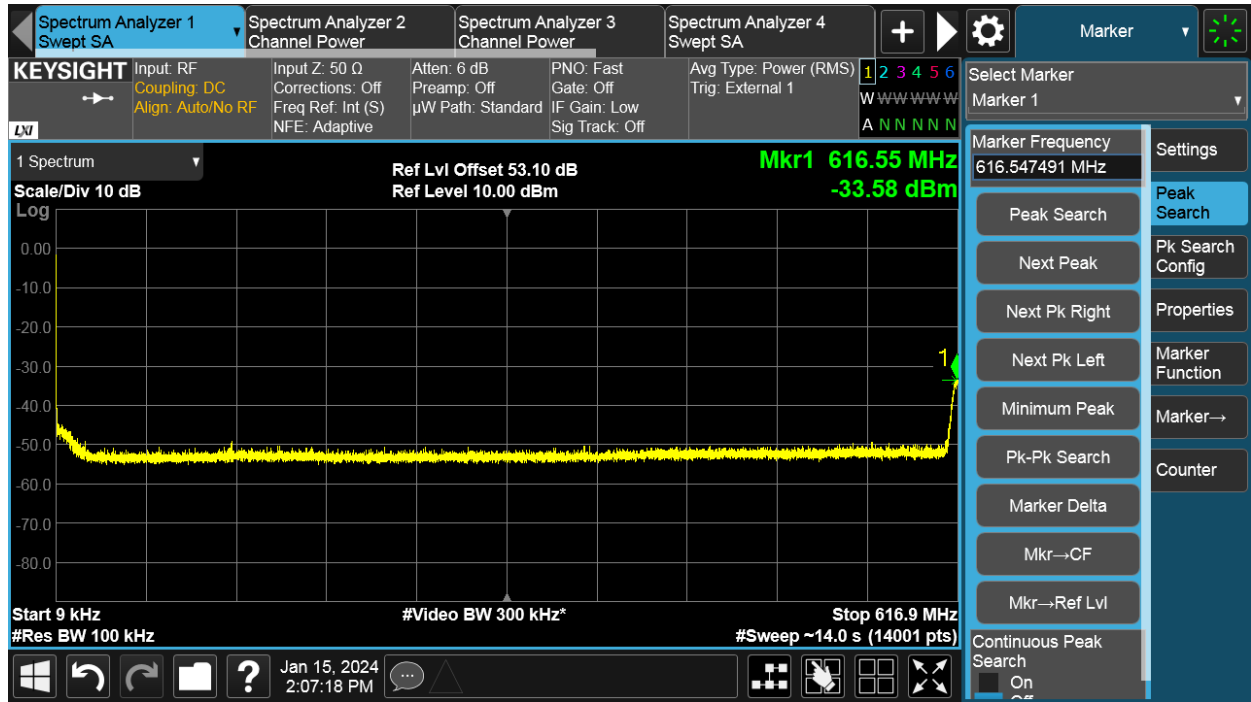

TEST REPORT

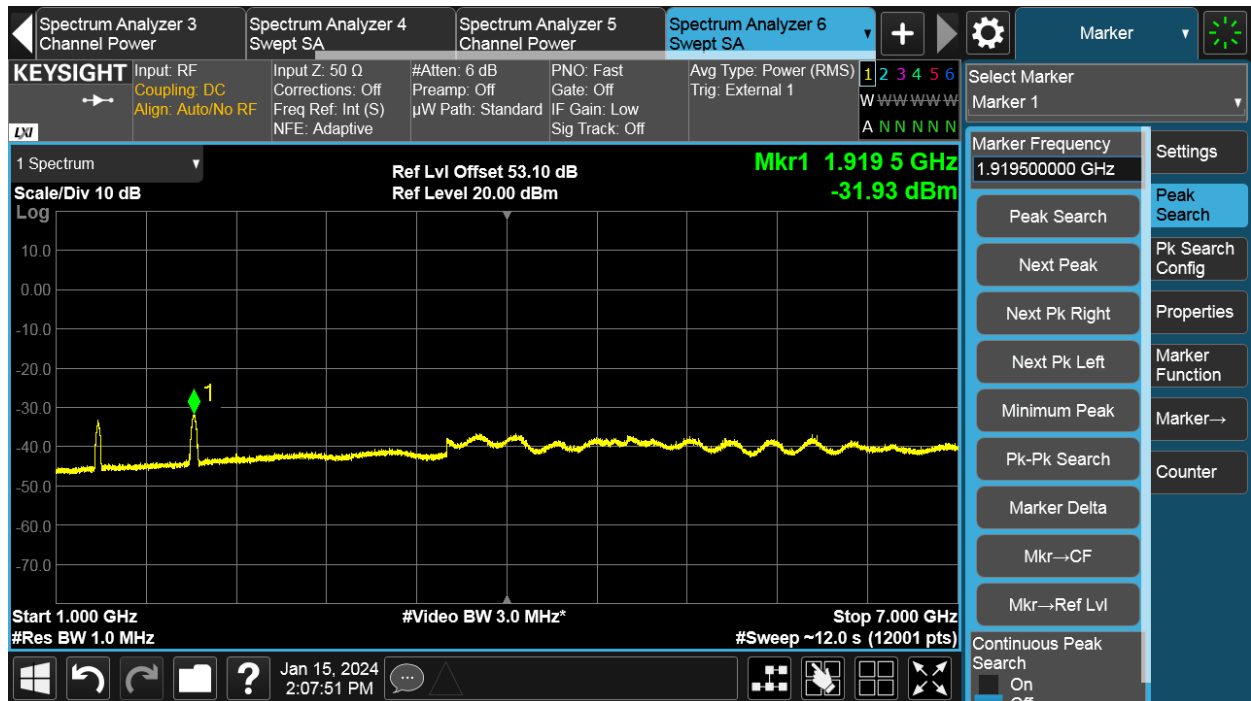
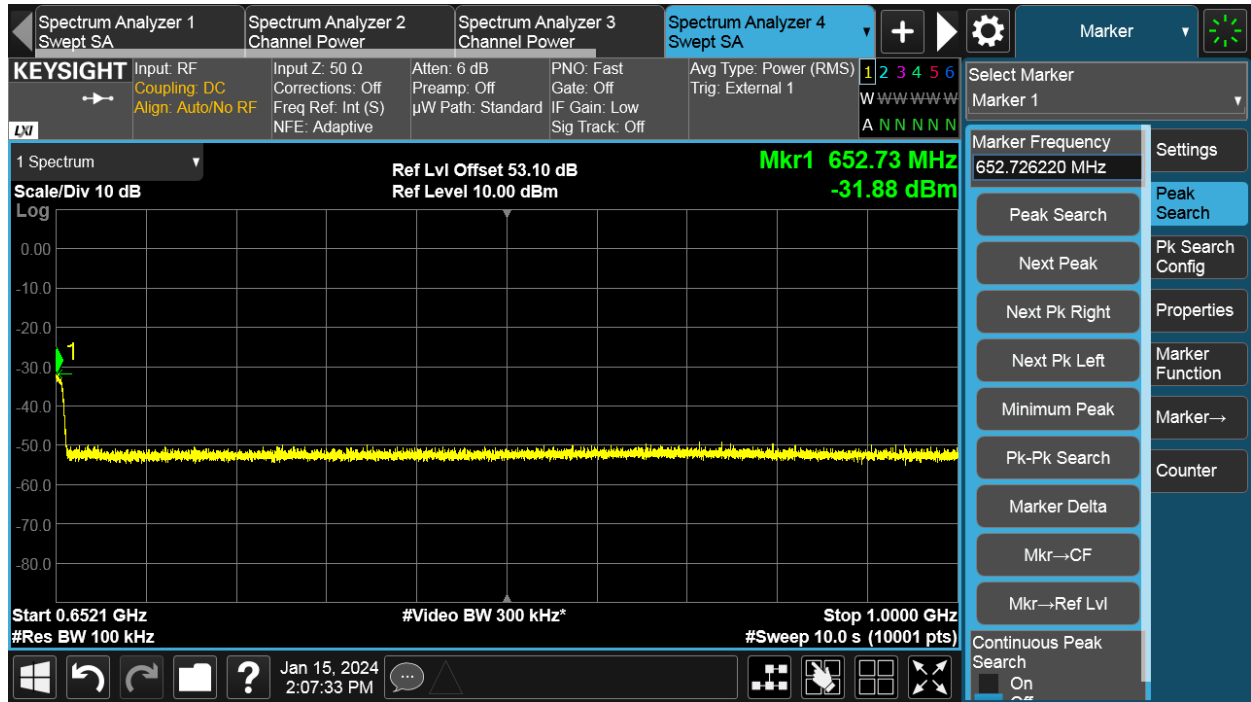

Antenna Port	Channel Position	NR Modulation	NR Channel Bandwidth (MHz)	Limit (dBm)
C	B	16QAM	30	-19.02
C	M	16QAM	30	-19.02
C	T	16QAM	30	-19.02

Channel Position B

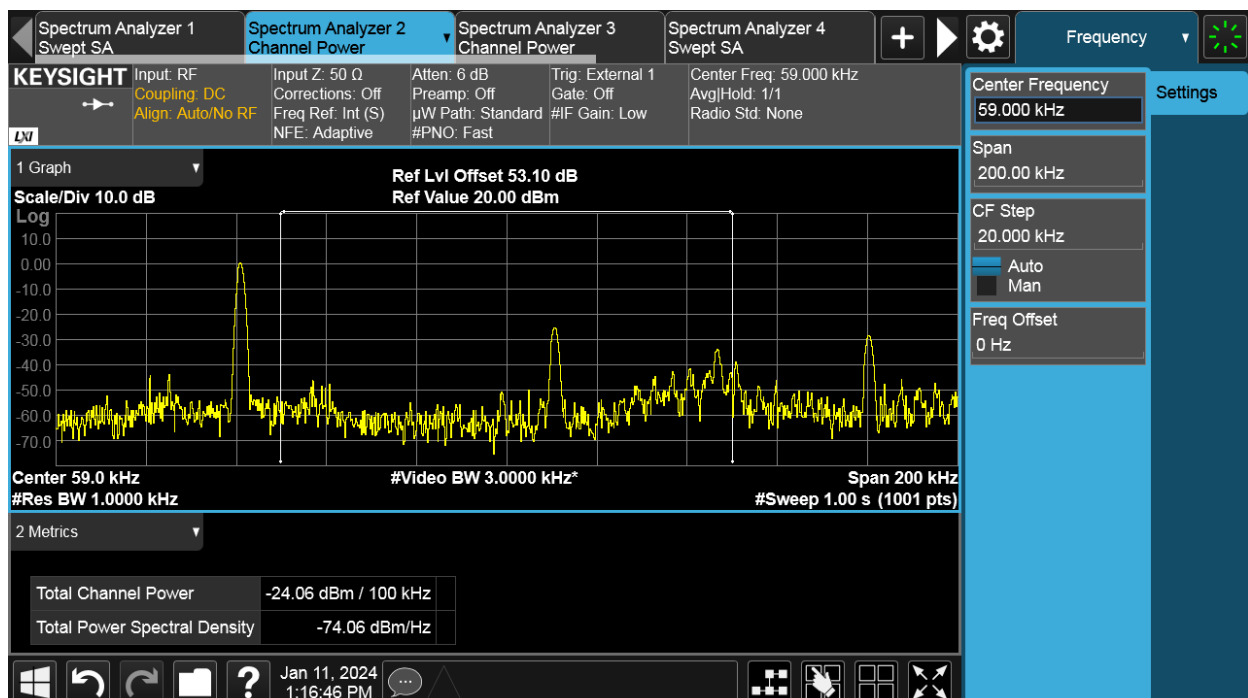
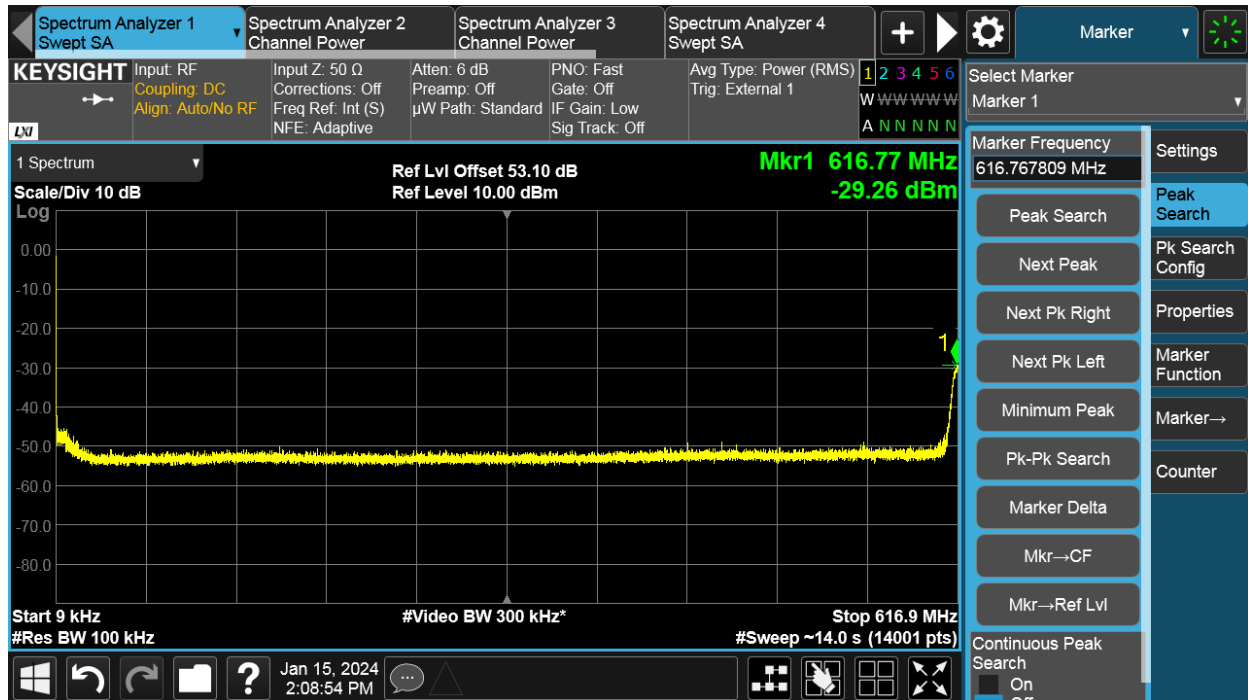

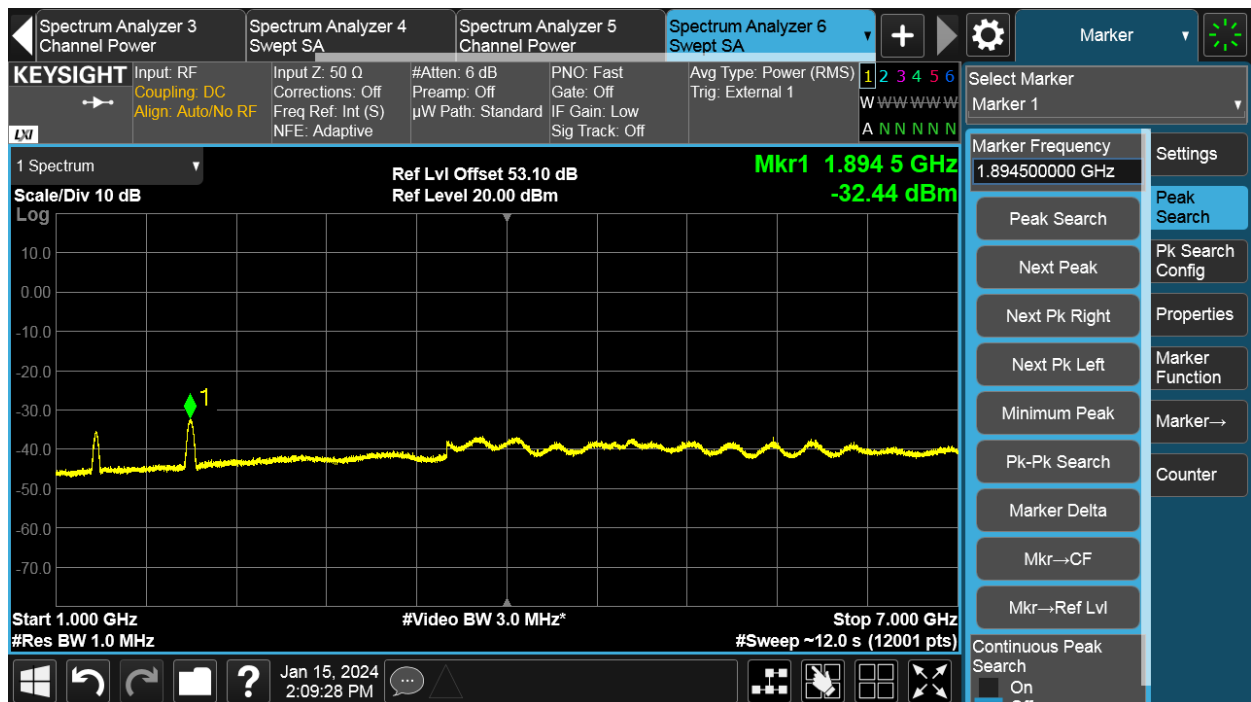
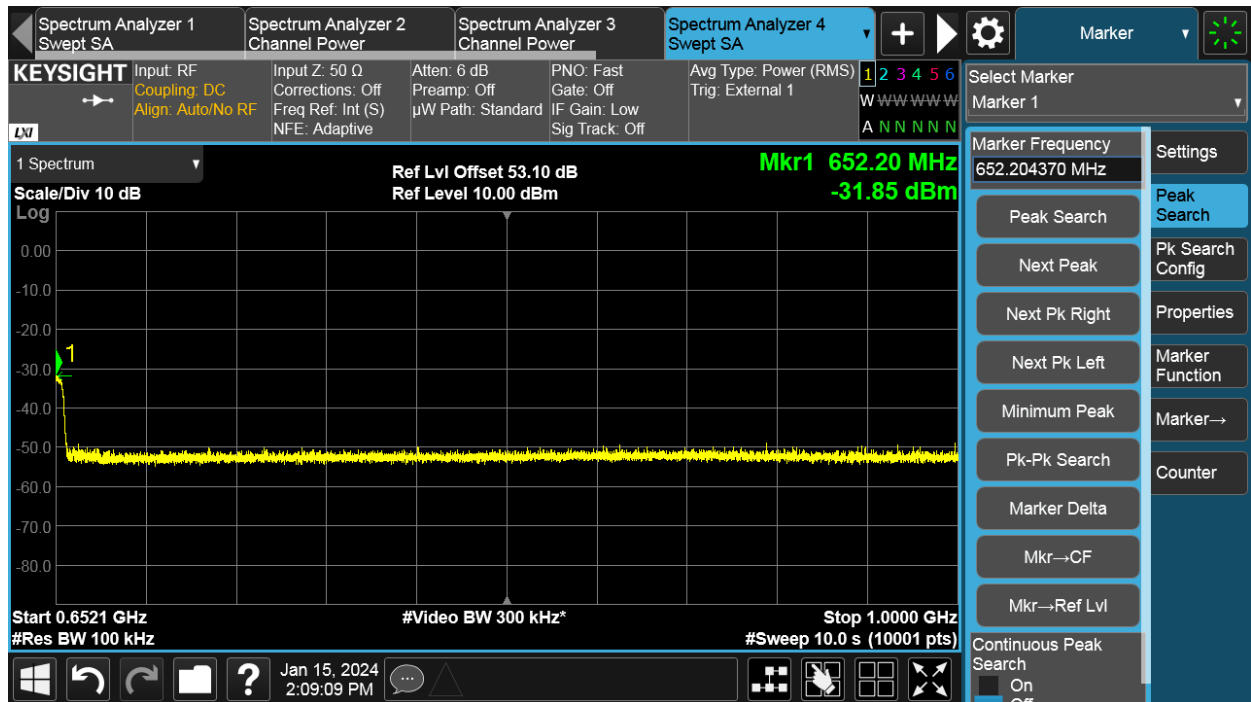

Channel Position M

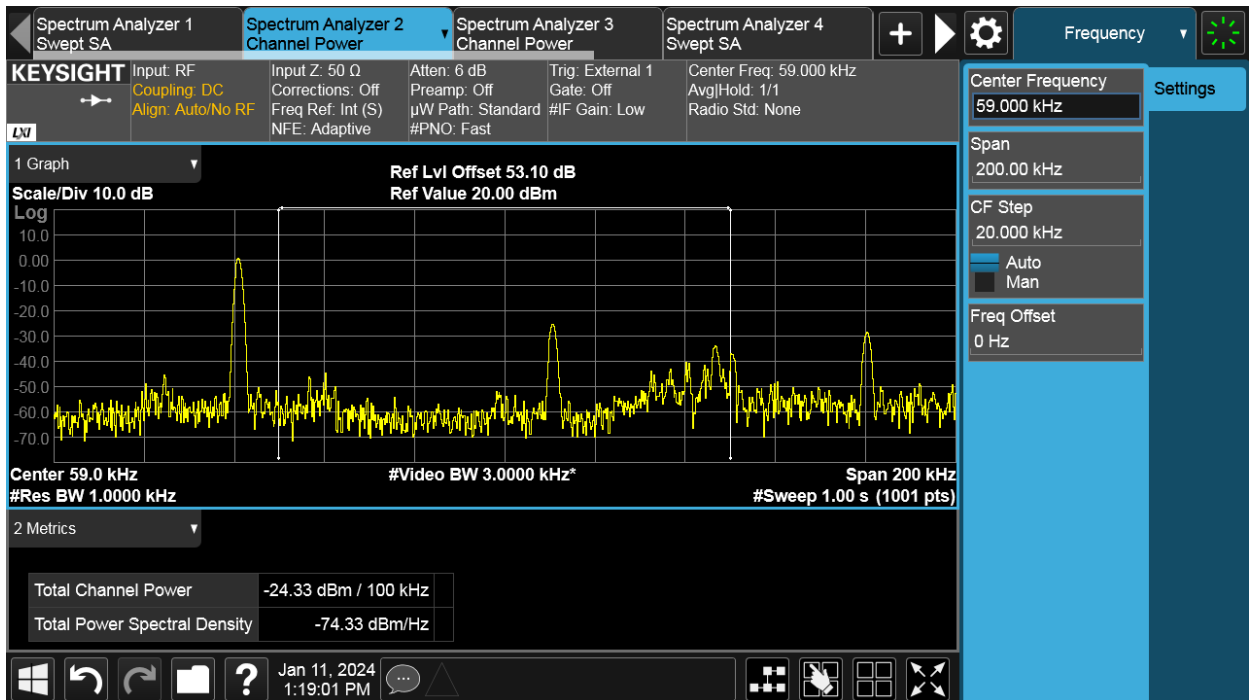
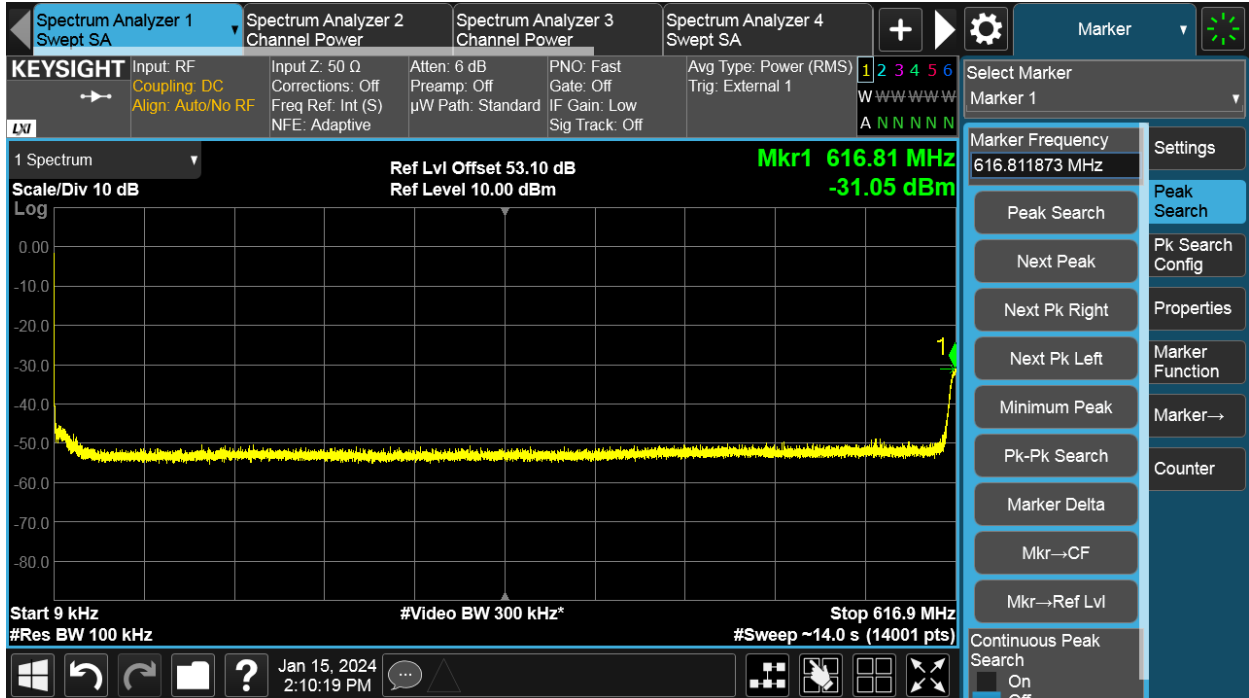

TEST REPORT

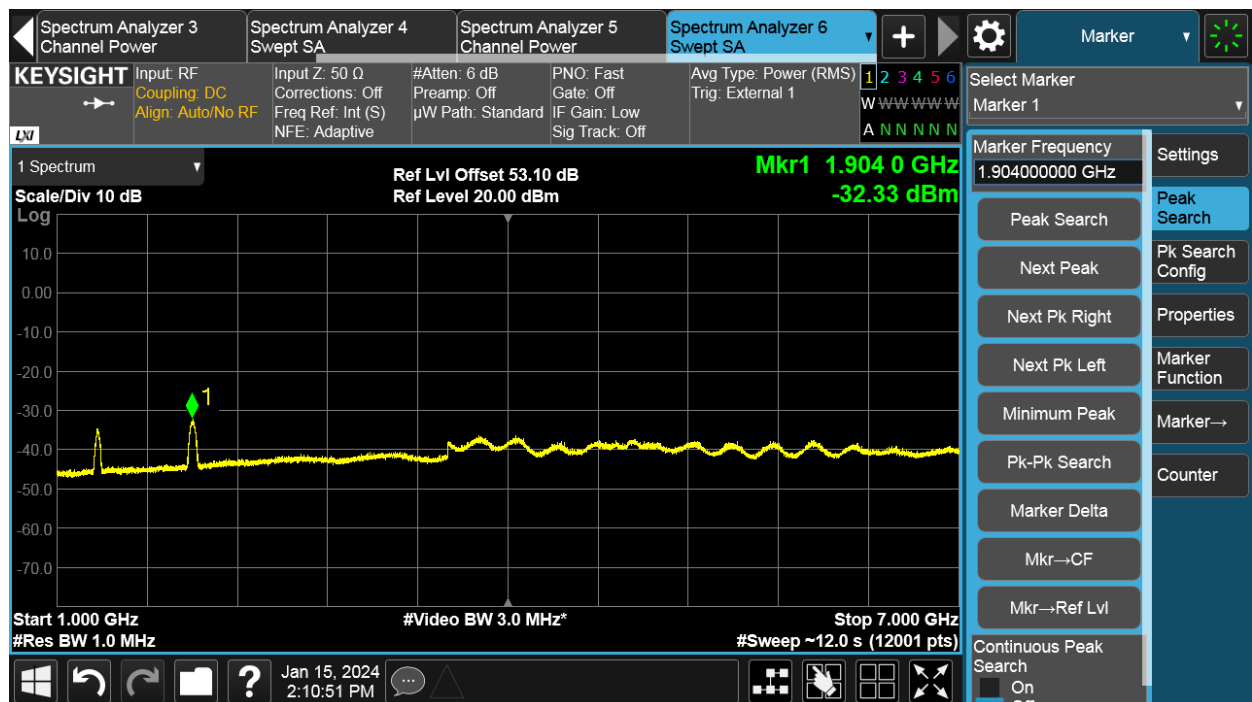
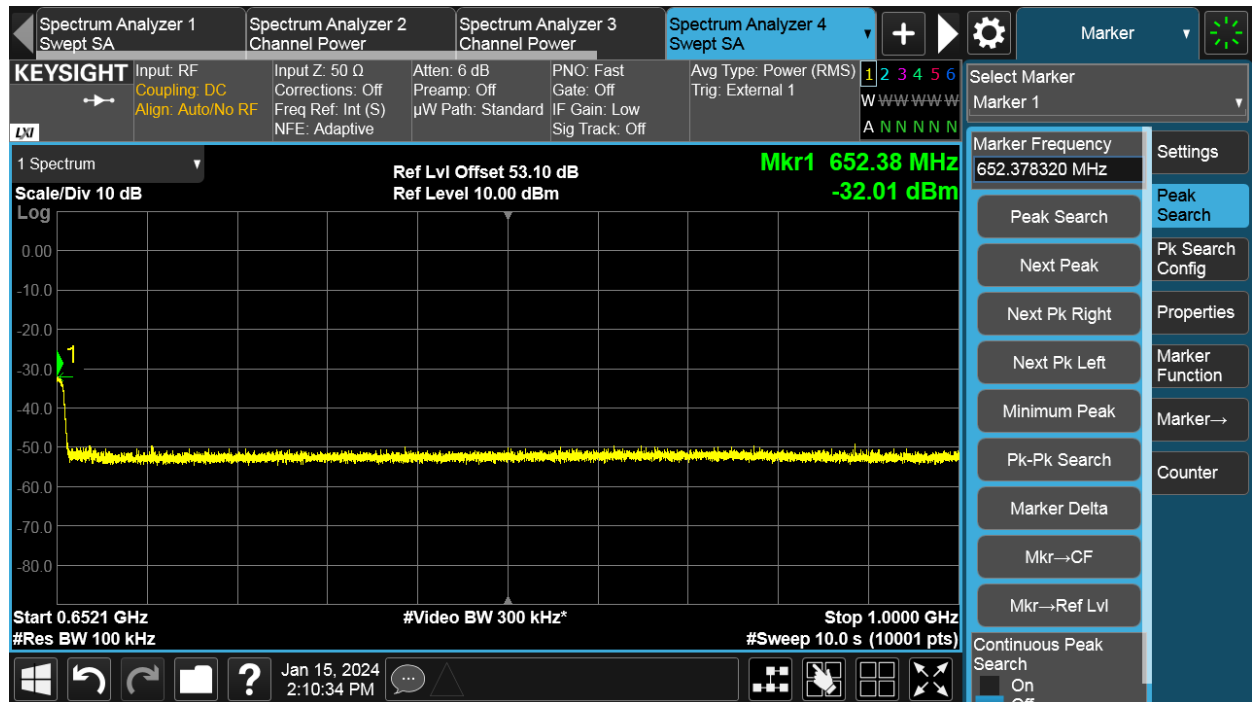

Channel Position T

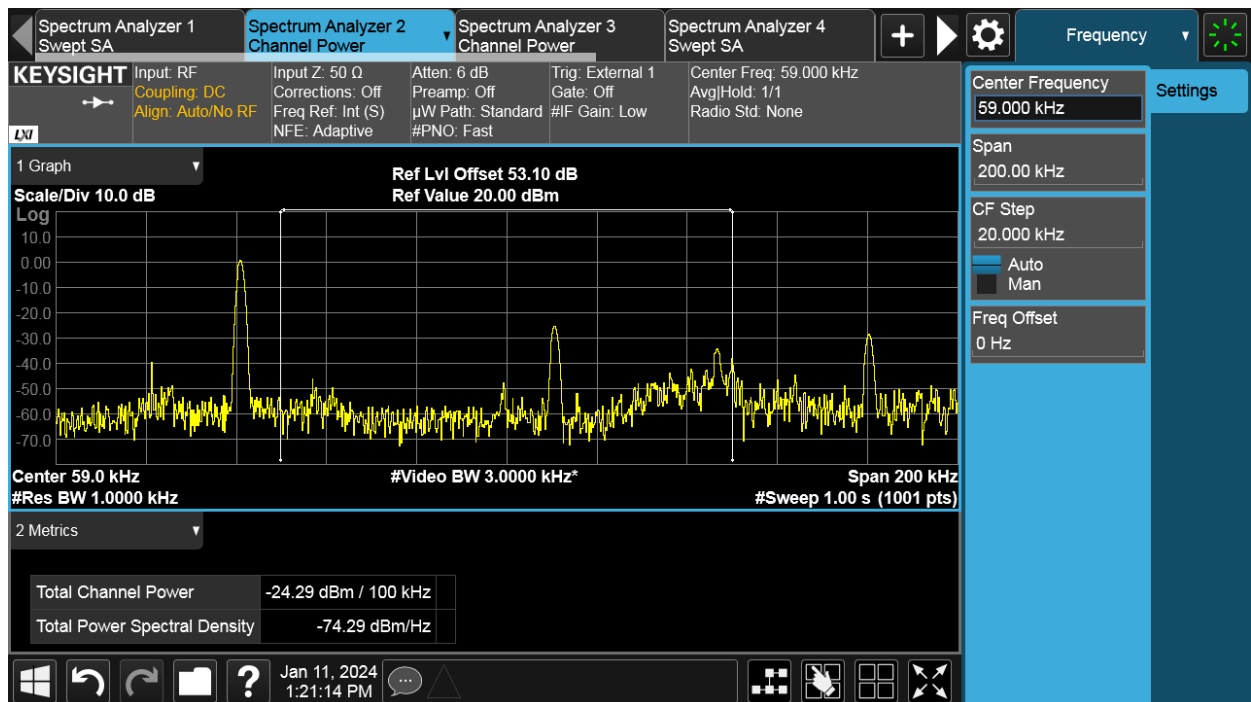
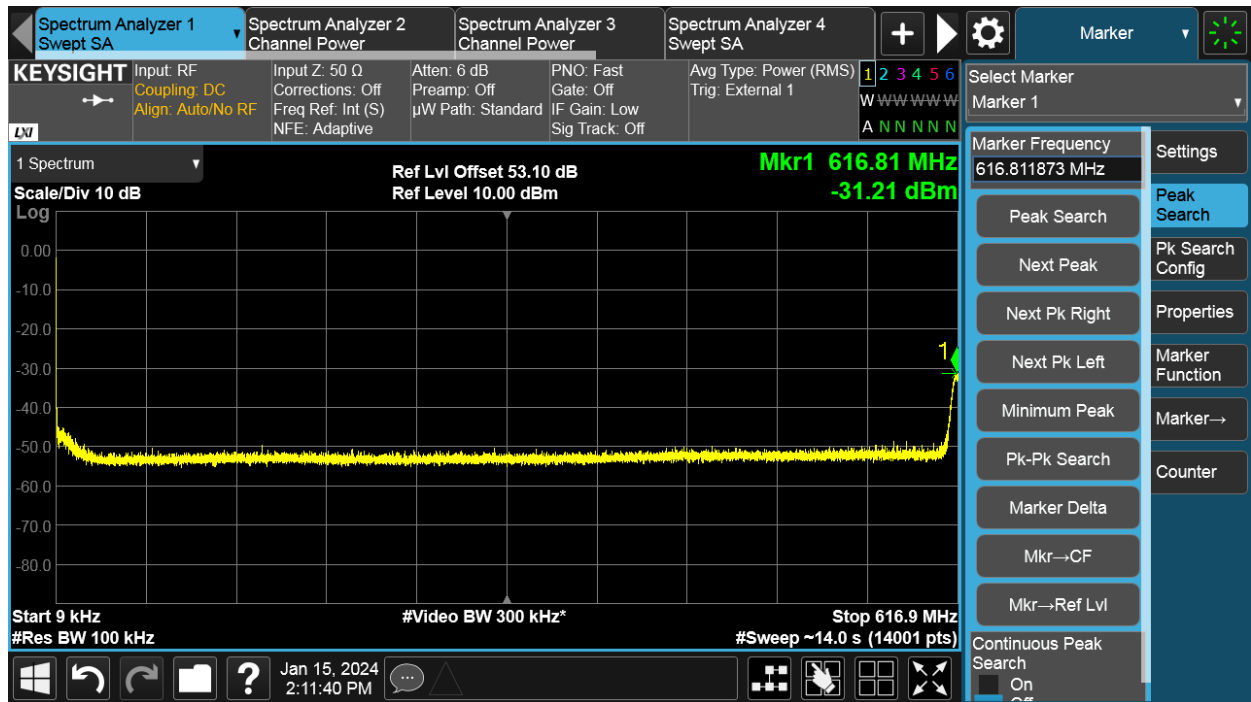

TEST REPORT

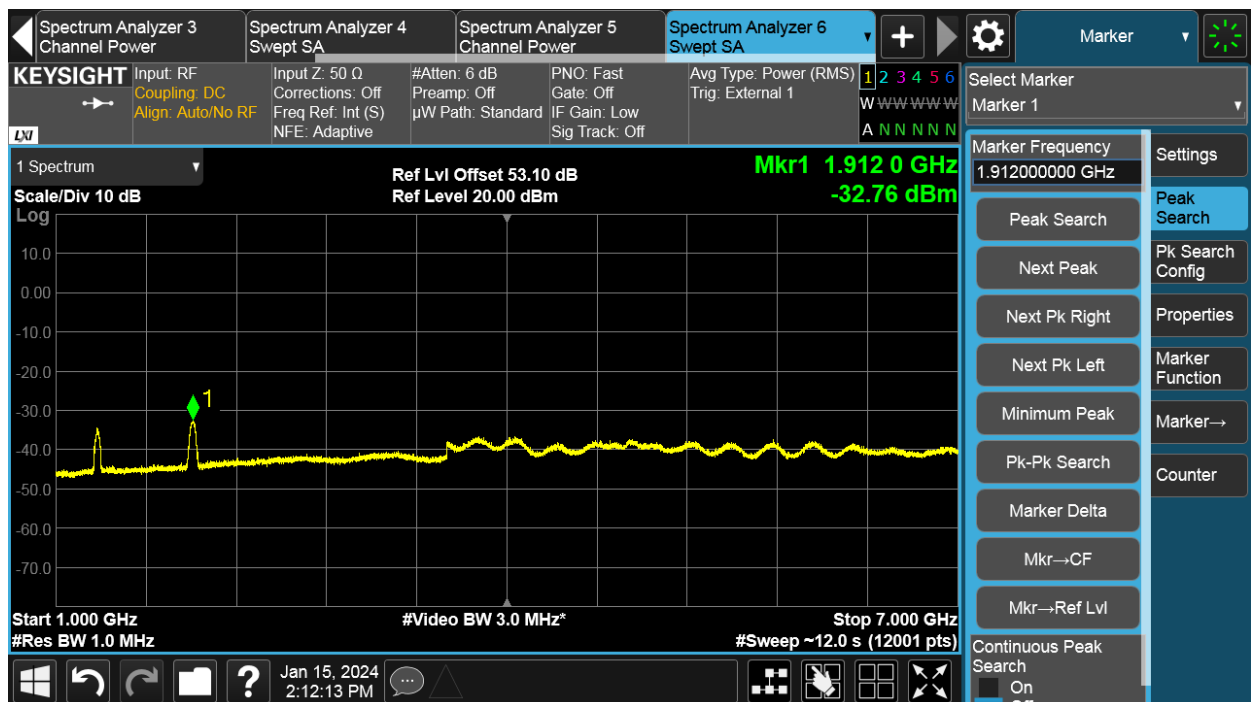
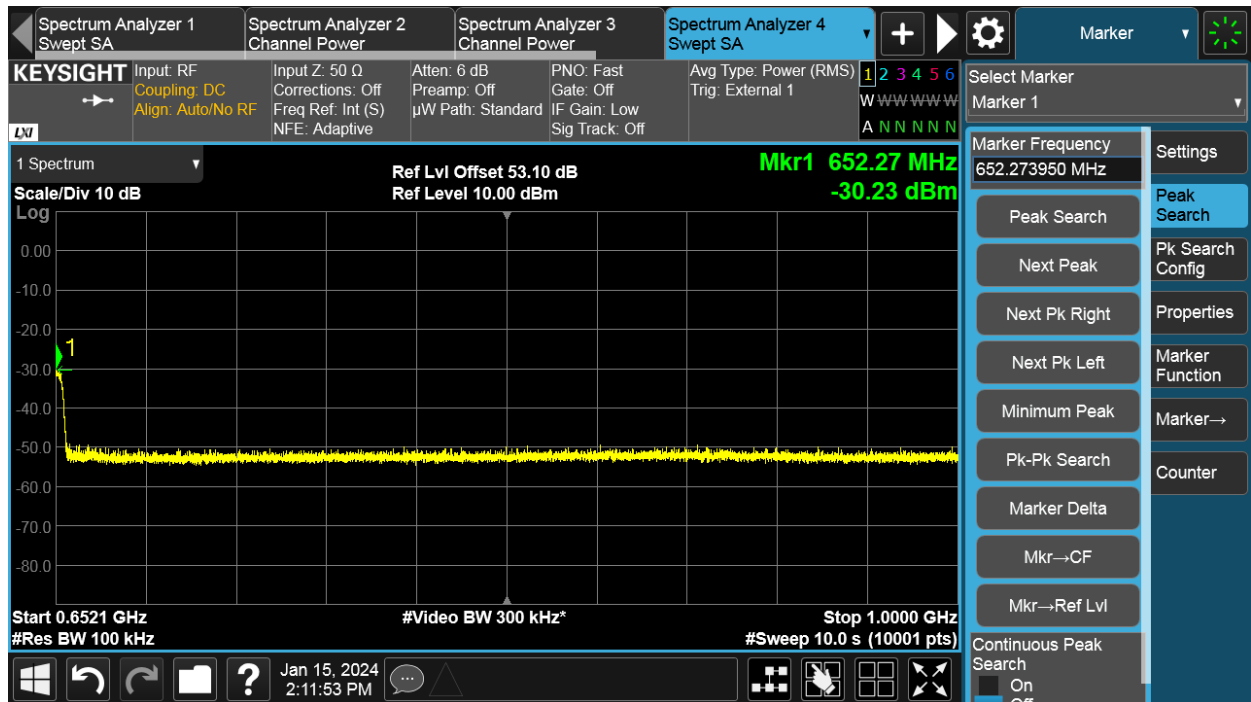

Antenna Port	Channel Position	NR Modulation	NR Channel Bandwidth (MHz)	Limit (dBm)
C	M	16QAM	35	-19.02

Channel Position M

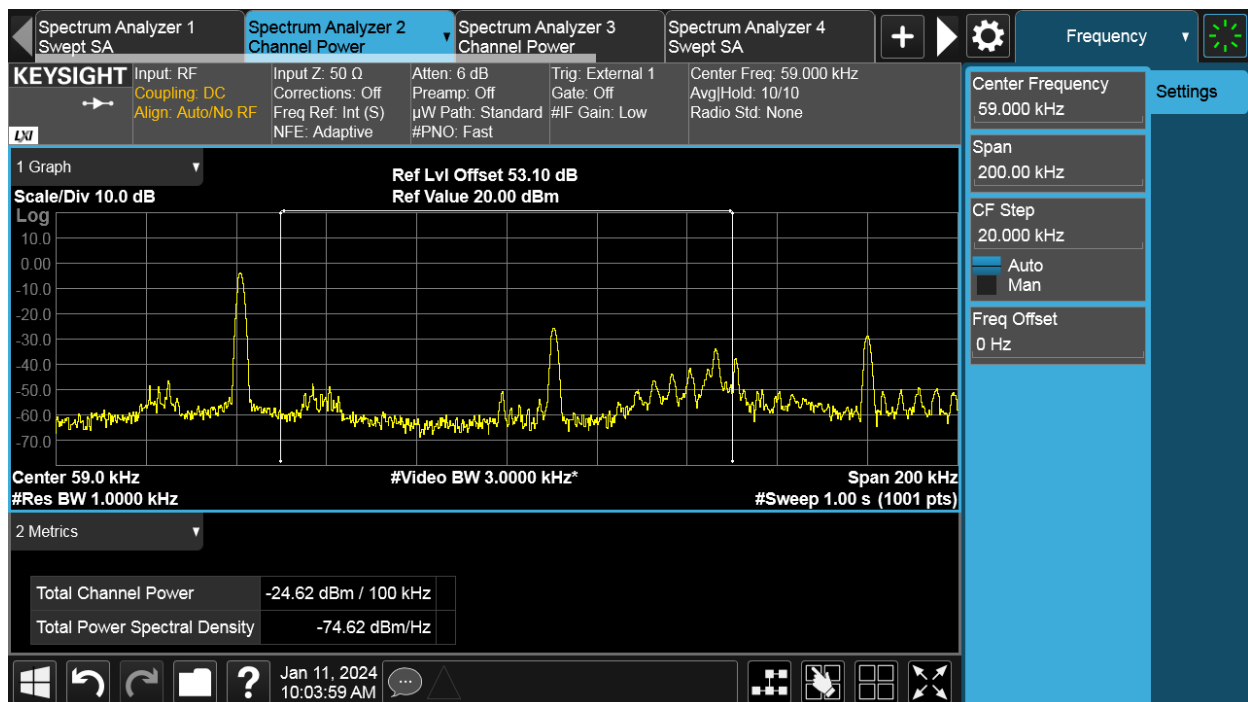
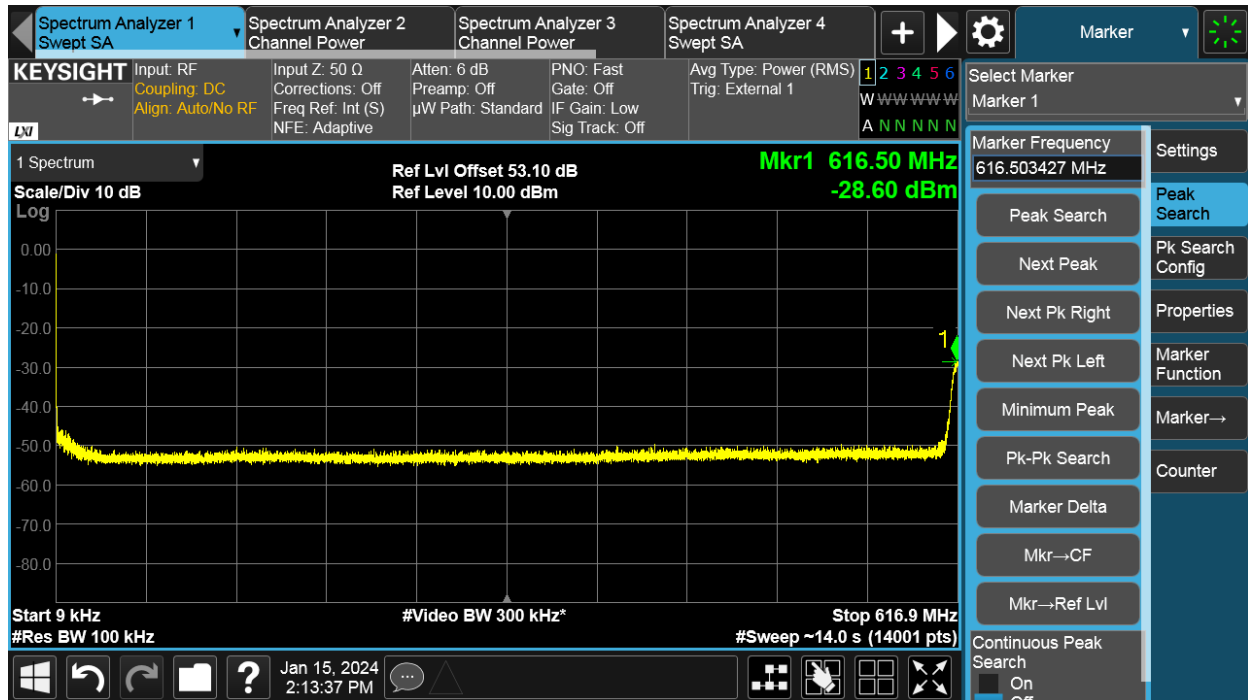

TEST REPORT

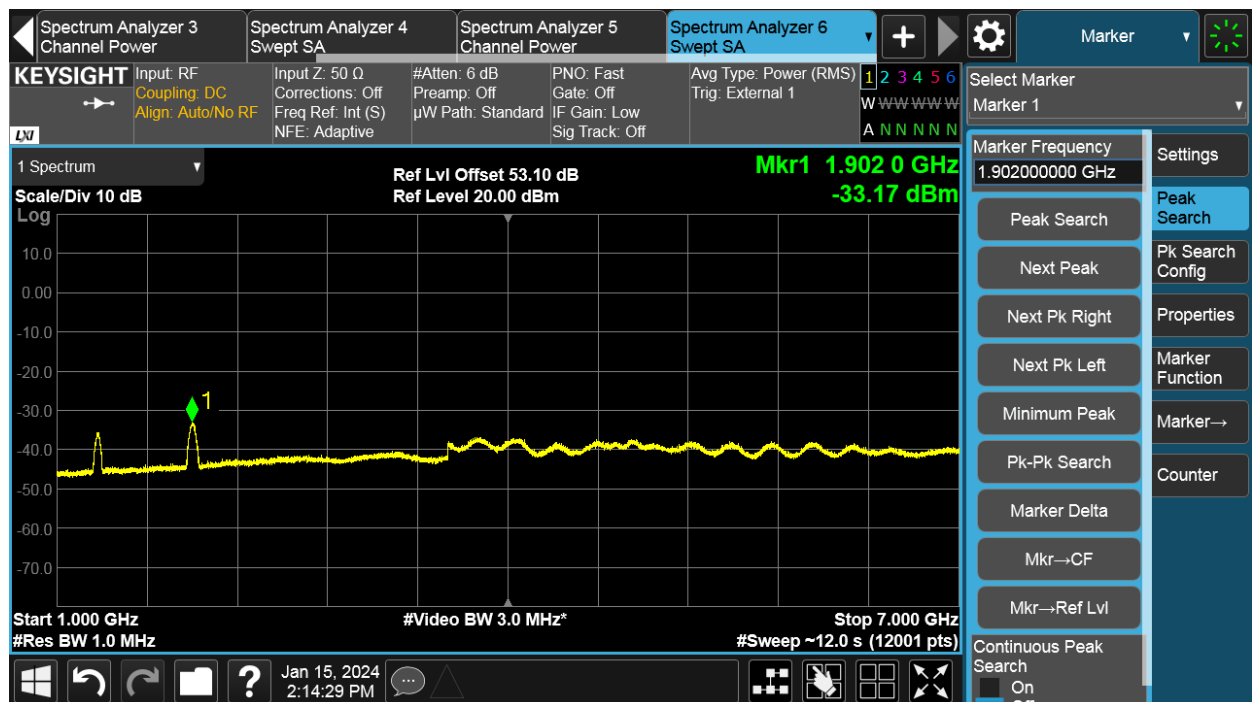
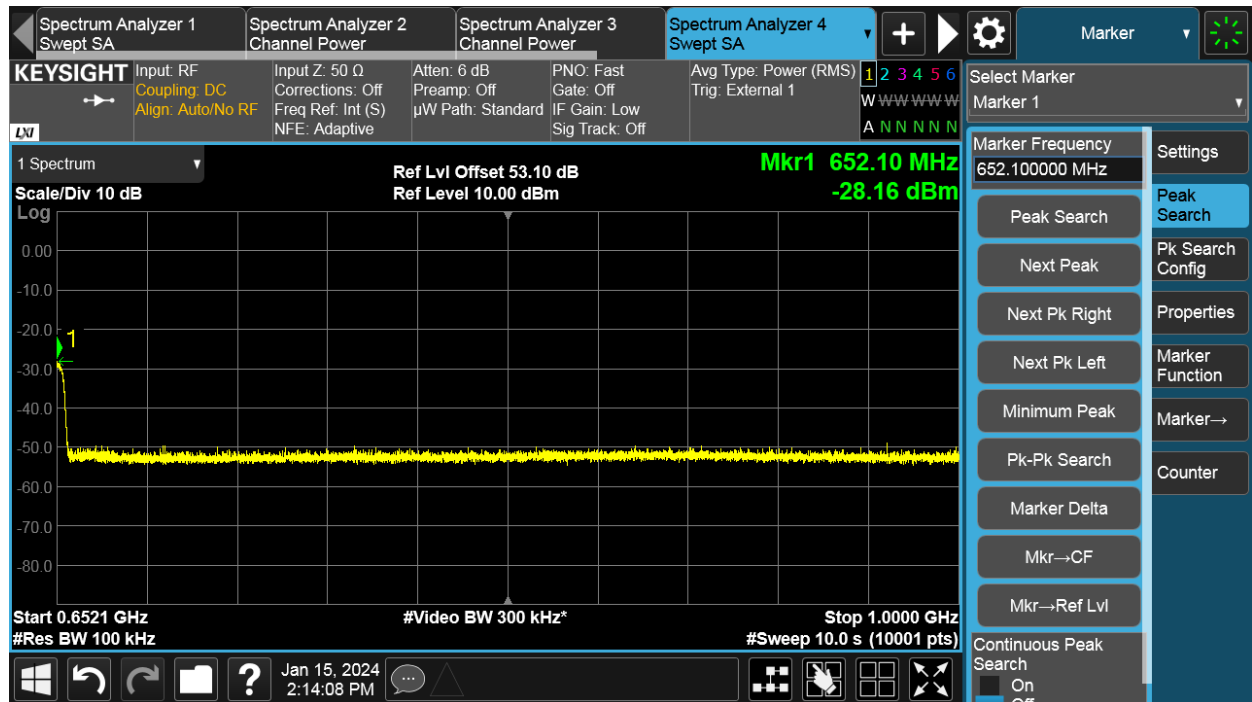

7 Frequency Stability

Test result: **Tested**

7.1 Limit

The frequency stability shall be sufficient to ensure that the fundamental emissions stay within the authorized bands of operation.

7.2 Measurement Procedure

Temperature Variation

The EUT was tested over the temperature range -40°C to +55°C in 10°C steps with -48 VDC Power Supply. At each temperature step, the Base Station was configured to transmit at maximum power on the middle channel of the operating band.

Voltage Variation

The EUT was tested at the supplied voltages varied from 85 to 115 percent of the nominal values of -48 VDC. At +20°C, the Base Station was configured to transmit at maximum power on the middle channel of the frequency block.

7.3 Measurement result

Frequency Error – Temperature Variation

NR-1C, Channel Bandwidth: 35MHz

Antenna Port	Modulation	Temperature (°C)	Frequency Stability (Hz)		
			Channel Position B	Channel Position M	Channel Position T
C	16QAM	-40	-	-0.71	-
		-30	-	-0.92	-
		-20	-	-0.77	-
		-10	-	-0.75	-
		0	-	-0.81	-
		10	-	-0.72	-
		20	-	-0.76	-
		30	-	-0.76	-
		40	-	-0.72	-
		50	-	-0.82	-
		55	-	-0.81	-

Frequency Error – Voltage Variation

NR-1C, Channel Bandwidth: 35MHz

Antenna Port	Modulation	Temperature (°C)	Supply Voltage (V)	Frequency Stability (Hz)		
				Channel Position B	Channel Position M	Channel Position T
C	16QAM	20	-40.8	-	-0.86	-
			-48.0	-	-0.76	-
			-55.2	-	-0.72	-

***** END *****