



Choose Scandinavian trust

Radio Test report – Radio 4460 B2/25 B66 C

Project number:
421910-1TRFWL-R1

Applicant:
Ericsson Canada Inc.

Product name:
Radio 4460

Model (PMN):
Radio 4460 44B2/25 44B66 C

Part number:
KRC 161 912/3

FCC ID:
TA8AKRC161912-3

ISED Reg. Number:
287AB-AS1619123

HVIN:
AS1619123

Requirements/Summary:

Standard	Environmental phenomenon	Compliance
FCC 47 CFR Part 27	Miscellaneous wireless communications services	Yes
FCC 47 CFR Part 24, Subpart E	Broadband Personal Communications Services (PCS)	Yes
RSS-133 Issue 6 A1, Jan 18, 2018	2 GHz Personal Communications Services	Yes
RSS-139 Issue 3, July 16, 2015	Advanced Wireless Services (AWS) Equipment Operating in the Bands 1710–1780 MHz and 2110–2180 MHz	Yes
RSS-170 Issue 3, July 9, 2015	Ancillary Terrestrial Component (ATC) Equipment Operating in the Mobile-Satellite Service (MSS) Bands AWS-4 (2180–2200MHz) Limitation as per IC P9 Licensing Agreement https://www.ic.gc.ca/eic/site/smt-gst.nsf/eng/sf11536.html	Yes

Date of issue: June 29, 2021

Andrey Adelberg, Senior EMC/Wireless Specialist

Tested by

Signature

Kevin Rose, Wireless/EMC Specialist

Reviewed by

Signature



Two test locations

Company name	Nemko Canada Inc.	
Address	303 River Road	349 Terry Fox
City	Ottawa	Ottawa
Province	Ontario	Ontario
Postal code	K1V 1H2	K2K 2V6
Country	Canada	Canada
Telephone	+1 613 737 9680	+1 613 963 8000
Facsimile	+1 613 737 9691	
Toll free	+1 800 563 6336	
Website	www.nemko.com	
Site number	FCC test site registration number: CA2040, IC: 2040A-4 (3 m semi anechoic chamber)	

Limits of responsibility

Note that the results contained in this report relate only to the items tested and were obtained in the period between the date of initial receipt of samples and the date of issue of the report.

This test report has been completed in accordance with the requirements of ISO/IEC 17025. All results contain in this reAnt Are within Nemko Canada's ISO/IEC 17025 accreditation.

Copyright notification

Nemko Canada Inc. authorizes the applicant to reproduce this report provided it is reproduced in its entirety and for use by the company's employees only. Any use which a third party makes of this report, or any reliance on or decisions to be made based on it, are the responsibility of such third parties.

Nemko Canada Inc. accepts no responsibility for damages, if any, suffered by any third party as a result of decisions made or actions based on this report.

© Nemko Canada Inc.

Table of contents

Table of contents	3
Section 1. Report summary	4
1.1 Applicant and manufacturer	4
1.2 Test specifications	4
1.3 Test method	4
1.4 Statement of compliance	4
1.5 Test report revision history	4
Section 2. Summary of test results.....	5
2.1 Testing location	5
2.2 Testing period	5
2.3 Sample information.....	5
2.4 FCC Part 27/24 test results	6
2.5 RSS-133/139/170 test results.....	6
Section 3. Equipment under test (EUT) details	7
3.1 EUT information	7
3.2 Product description and theory of operation	9
3.3 EUT test details.....	10
3.4 EUT setup diagram	22
3.5 Setup photographs	23
3.6 Setup photographs, continued.....	24
Section 4. Engineering considerations.....	25
4.1 Modifications incorporated in the EUT.....	25
4.2 Technical judgment	25
4.3 Deviations from laboratory tests procedures	25
Section 5. Test conditions.....	26
5.1 Atmospheric conditions	26
5.2 Power supply range.....	26
Section 6. Measurement uncertainty	27
6.1 Uncertainty of measurement	27
Section 7. Test equipment	28
7.1 Test equipment list.....	28
Section 8. Testing data	29
8.1 Maximum output power at RF antenna connector (Band 66).....	29
8.2 Transmitter output power (EIRP) and antenna height (Band 2/25).....	48
8.3 Spurious emissions at RF antenna connector (Band 66).....	71
8.4 Radiated spurious emissions (Band 66 & 2/25)	120
8.5 Spurious out-of-band emissions (Band 2/25)	125
8.6 Receiver conducted spurious emissions (Band 66 & 2/25).....	220
8.7 Frequency stability (Band 66).....	221
8.8 Frequency stability (Band 2/25)	222
8.9 Occupied bandwidth (Band 66)	223
8.10 Occupied bandwidth (Band 2/25).....	230
Section 9. Block diagrams of test setups	238
9.1 Radiated emissions set-up for frequencies below 1 GHz.....	238
9.2 Radiated emissions set-up for frequencies above 1 GHz.....	238
9.3 Conducted emissions set-up	239

Section 1. Report summary

1.1 Applicant and manufacturer

Company name	Ericsson Canada Inc.
Address	349 Terry Fox Drive, Ottawa, ON, Canada, K2K 2V6

1.2 Test specifications

FCC 47 CFR Part 2	Frequency Allocations and Radio Treaty Matters; General Rules and Regulations
FCC 47 CFR Part 24, Subpart E	Broadband Personal Communications Services (PCS)
FCC 47 CFR Part 27	Miscellaneous wireless communications services (2110–2200 MHz)
RSS-133 Issue 6 A1, Jan. 18, 2018	2 GHz Personal Communications Services
RSS-139 Issue 3, July 16, 2015	Advanced Wireless Services (AWS) equipment operating in the bands 1710–1780 MHz and 2110–2180 MHz
SRSP-510, Issue 5, February 2009	Technical Requirements for Personal Communications Services (PCS) in the Bands 1850–1915 MHz and 1930–1995 MHz
RSS-170 Issue 3, July 9, 2015*	Ancillary Terrestrial Component (ATC) Equipment Operating in the Mobile-Satellite Service (MSS) Bands
RSS-Gen, Issue 5, April 2018	General Requirements for Compliance of Radio Apparatus

*Equipment operating in the ancillary terrestrial component (ATC) of the frequency bands 2000–2020 MHz and 2180–2200 MHz is certified under RSS-170. Limitations specified under Industry Canada P9 Licensing Agreement applied as per <https://www.ic.gc.ca/eic/site/smt-gst.nsf/eng/sf11536.html>

1.3 Test method

ANSI C63.26-2015	American National Standard for Compliance Testing of Transmitters Used in Licensed Radio Services
KDB 662911 D01	Multiple Transmitter Output v02r01
KDB 662911 D02	MIMO with Cross-Polarized Antennas v01

1.4 Statement of compliance

In the configuration tested, the EUT was found compliant. Testing was completed against customer test plan. Results obtained indicate that the product under test complies in full with the requirements tested.

This test report (**421910-1TRFWL-R1**) applies to the *Radio 4460 44B2/25 44B66 C* with part number *KRC 161 912/3*. See “Summary of test results” for full details.

EUT Configuration(s) SRO/MRO:

B2/B25:	B66:
LTE/NR: 5, 10, 15, 20 MHz, Max 6 Carriers	LTE/NR: 5, 10, 15, 20 MHz (Max 6 Carriers)
WCDMA/CDMA/GSM: Max 1 Carrier	WCDMA: Max 1 Carrier
LTE + NR	LTE + NR
LTE/NR + WCDMA/CDMA/GSM	LTE/NR + WCDMA
WCDMA+GSM	

1.5 Test report revision history

Table 1.5-1: Test report revision history

Revision #	Date of issue	Details of changes made to test report
TRF	June 29, 2021	Original report issued



Section 2. Summary of test results

2.1 Testing location

Test location (s) Ottawa

2.2 Testing period

Test start date May 12, 2021 Test end date May 26, 2021

2.3 Sample information

Receipt date May 12, 2021 Nemko sample ID number 1

2.4 FCC Part 27/24 test results

Table 2.4-1: FCC results summary

Part	Test description	Verdict
§27.50(b)	Maximum output power at RF antenna connector	Pass
§27.53	Spurious emissions at RF antenna connector	Pass
§27.53	Radiated spurious emissions (conducted and radiated)	Pass
§24.229	Frequencies	Pass ¹
§24.232(a)(2)	Power and antenna height limits for base stations with BW greater than 1 MHz	Pass
§24.238(a)	Emission limitations for Broadband PCS equipment – out of band emissions (conducted and radiated)	Pass
§2.1049	Occupied bandwidth	Pass

Notes: Only tests requested by the client have been performed

¹EUT transmits within 1930–1995 MHz frequency range

2.5 RSS-133/139/170 test results

Table 2.5-1: ISED results summary

Part	Test description	Verdict
RSS-133, 6.1	Frequency Plan	Pass ¹
RSS-133, 6.2	Types of Modulation	Pass ²
RSS-133, 6.4	Transmitter Output Power and Equivalent Isotropically Radiated Power	Pass
RSS-133, 6.5	Transmitter Unwanted Emissions (conducted and radiated)	Pass
RSS-139, 4.1	Transmitter output power and Equivalent Isotropic Radiated Power (e.i.r.p.)	Pass
RSS-139, 4.2	Spurious emissions at RF antenna connector	Pass
RSS-139, 4.2	Radiated spurious emissions (conducted and radiated)	Pass
RSS-170, 5.3	Transmitter output power and Equivalent Isotropic Radiated Power (e.i.r.p.)	Pass
RSS-170, 5.4	Spurious emissions at RF antenna connector	Pass
RSS-170, 5.4	Radiated spurious emissions (conducted and radiated)	Pass
RSS-Gen, 6.7	Occupied bandwidth	Pass
RSS-Gen, 7.4	Receiver conducted spurious emissions	Pass

Notes: Only tests requested by the client have been performed

¹EUT transmits within 1930–1995 MHz frequency range

²EUT employs digital modulation (QPSK to 256-QAM)

ATC Base Station Equipment operating in bands 2000–2020 MHz and 2180–2200 MHz

The unwanted emissions of ATC base station equipment transmitting in the bands 2000–2020 MHz and 2180–2200 MHz shall comply with the following:

- (1) The power of any unwanted emissions at frequencies outside the equipment's operating frequency block shall be attenuated below the transmitter power P (dBW), by $43 + 10 \log p$ (watts), dB.
- (2) For equipment operating in the band 2180–2200 MHz, in addition to (1), the power of any emissions on all frequencies between 2200 MHz and 2290 MHz shall not exceed an e.i.r.p. of $-100.6 \text{ dBW}/4 \text{ kHz}$ ($-70.6 \text{ dBm}/4 \text{ kHz}$).

*** This requirement is for implementation and is enforced at the time of licensing. Therefore, results are not included in this report.**

Note: Requirement number 2 above is amended as detailed in the following ISED document: <https://www.ic.gc.ca/eic/site/smt-gst.nsf/eng/sf11536.html>

Section 3. Equipment under test (EUT) details

3.1 EUT information

Product name	Radio 4460	
Model	Radio 4460 44B2/25 44B66 C	
Part number	KRC 161 912/3	
Revision	R1C/A	
Serial number	E23C828735	
Antenna ports	4 TX/RX Ports	
RF BW / IBW	B2 IBW DL: 60 MHz B2 IBW UL: 60 MHz B25 IBW DL: 65 MHz B25 IBW UL: 65 MHz	B66 IBW DL: 90 MHz B66 IBW UL: 70 MHz
FDD	B2/25: 80 MHz	B66: 400 MHz
Frequency	B2 TX (DL): 1930 – 1990 MHz B2 RX (UL): 1850 – 1910 MHz B25 TX (DL): 1930–1995 MHz B25 RX (UL): 1850–1915 MHz	B66 TX (DL): 2110–2200 MHz B66 RX (UL): 1710–1780 MHz
Nominal O/P per Antenna port	140 W (51.46 dBm): 80 W per Band	
Nominal O/P per Antenna port per Band	Single Carrier: 1 × 80 W (49.03 dBm/Carrier) 2 Carrier: 2 × 40 W (46.02 dBm/Carrier total) 3 Carrier: 3 × 26.7 W (44.26 dBm/Carrier total)	
Accuracy (nominal)	±0.1 ppm	
Nominal voltage	-48 V _{DC} @ 40 A	
RAT	B2: LTE, (LTE+NB-IoT (IB, GB)), NR, GSM, WCDMA, CDMA B25: LTE, (LTE+NB-IoT (IB, GB)), NR	B66: LTE, (LTE+NB-IoT (IB, GB)), NR, WCDMA (B4)
Modulation	LTE: QPSK, 16 QAM, 64 QAM, 256 QAM NR: QPSK, 16 QAM, 64 QAM, 256 QAM NB-IoT: QPSK WCDMA: QPSK, 16 QAM, 64 QAM GSM: GMSK, 8-PSK, AQPSK CDMA: QPSK, 8-PSK, 16 QAM	
Channel bandwidth	LTE: 5, 10, 15, 20 MHz NR: 5, 10, 15, 20 MHz WCDMA: 5 MHz CDMA: 1.25MHz GSM: 200 kHz	
Channel bandwidth LTE + NB-IoT	LTE+NB-IoT IB: 5, 10, 15, 20 MHz LTE+NB-IoT GB: 10, 15, 20 MHz NB-IoT (GB, IB): 200 kHz	
Maximum combined OBW per port	B25: 65 MHz	B66: 90 MHz
CPRI	2.5G, 4.9G, 9.8G, 10.1 Gbps	

Section 3:

Equipment under test (EUT) details



Channel raster	LTE: 100 kHz NR: 100 kHz WCDMA / GSM: 200 kHz CDMA: 50 kHz		
Regulatory requirements	Radio: FCC Part 2, 24, 27, RSS-Gen, RSS-133, RSS-139, (RSS-170 / IC P9 Licensing Agreement AWS-4) EMC: FCC Part 15, ICES-003 Safety: IEC/EN 62368-1, UL/CSA 62368-1 IEC/EN 60950-22, UL 50E /CAN/CSA, IEC/EN 60529, Type 3 Enclosure		
Emission Designator	LTE: 5M00W7D, 10M0W7D, 15M0W7D, 20M0W7D NR: 5M00W7D, 10M0W7D, 15M0W7D, 20M0W7D WCDMA: 5M00F9W GSM: 200KG7W CDMA: 1M25F9W		
Supported Configurations	Single Antenna, TX Diversity, MIMO, Carrier Aggregation, Ericsson Spectral Sharing (ESS)		
Operating temperature	-40 °C to +55 °C		
Total Power based on IBW	560 W total / radio (4 ports × 140 W)		
Supported carriers /band/ port SRO/MRO	Up to 6 carriers. LTE: Max 6 NR: Max 6 LTE + NB-IoT: GB Max 2, IB Max 2 WCDMA/CDMA/GSM: Max 1		
Carrier Configuration: B2/25: W, G, C are limited to B2 B66: W is limited to B4	B2/25	B66	
	SRO: LTE, NR, W, G, C	SRO: LTE, NR, WCDMA	
	MRO: L+NR, L+W, L+G, L+C, NR+W, NR+G, NR+C, C+NR+L, G+NR+L, W+NR+L	MRO: L+NR, L+W, NR+W, W+NR+L	
Total Power based on IBW	560 W (57.48 dBm) Total / Radio		140 W / Port (max)
Radio Band Power (max.)	Configurations /Port:	B2/25:	B66:
	1	80 W	60 W
	2	60 W	80 W
	3	70 W	70 W
RAT SC Carrier Power (max)	RAT	BW	PWR/Carrier(max)
	LTE/NR	5 MHz	20 W
	LTE/NR	10 MHz	40 W
	LTE/NR	15 MHz	60 W
	LTE/NR	20 MHz	80 W
	WCDMA	5 MHz	20 W
	GSM	200 kHz	20 W
	CDMA	1.25 MHz	20 W

3.2 Product description and theory of operation

EUT description of the methods used to exercise the EUT and all relevant ports:

Description/theory of operation	<p>Radio 4460 44B2B/B25 44B66 C (KRC 161 912/3) is a multi-standard remote Dual Band radio forming part of the Ericsson RBS (Radio Base Station) equipment. Radio 4460 provides radio access for mobile and fixed devices and is designed for the outdoor environment. Radio 4460 operates over 2 bands (Band 2/25 and Band 66) via 4 TX/RX ports connected directly into an integrated antenna. Radio unit installation is designed for pole, wall or rail mount options. A fiber optic interface (4) provides the RRU/RBS control and digital interface between the Radio and the RBS. Radio 4460 product is convection cooled and shall be mounted vertically.</p> <p>Output RF Power is rated at 4 x 140 W. Altitude during operation: Below 4000 m</p> <p>Radio 4460 is a synthesized Transceiver designed for use in the 3GPP (Third Generation Partnership Project) for LTE (Long Term Evolution) - E-UTRA Base Station, NR (New Radio), WCDMA, GSM and CDMA. Radio 4460 B2/25 B66 C is a 4TX/4RX remote radio unit (RRU). This RRU operates in Band 2/25 as defined by 3GPP. TX (DL): 1930–1995 MHz, RX (UL): 1850–1915 MHz and Band 66 TX (DL): 2110–2200 MHz, RX (UL): 1710–1780 MHz</p> <p>For LTE/NR, Radio 4460 B2/25 B66 supports modulations QPSK, 16QAM, 64QAM and 256QAM. Channel Bandwidth is configurable for 5, 10, 15 or 20 MHz. For WCDMA: QPSK, 16QAM, 64QAM; for GSM: GMSK, 8-PSK, AQPSK; for CDMA: QPSK, 8-PSK, 16QAM. The Radio transmits SRO/MRO in single carrier mode and multi carrier mode within the Band Specific IBW (Instantaneous Band Width). LTE NB-IoT is supported for IB and GB.</p> <p>Radio 4460 supports single and multi-beam FD MIMO (Multiple Input Multiple Output), Carrier Aggregation and ESS/DSS).</p>																																	
Ports/Interface	<table border="1"> <thead> <tr> <th>Port</th> <th>Description</th> </tr> </thead> <tbody> <tr> <td>ANT 1–16</td> <td>RF Output ports from 1 to 4</td> </tr> <tr> <td>Alarm</td> <td>Alarm</td> </tr> <tr> <td>ALD</td> <td>Antenna Line Device</td> </tr> <tr> <td>Data 1</td> <td>Optical Interface Data 1</td> </tr> <tr> <td>Data 2</td> <td>Optical Interface Data 2</td> </tr> <tr> <td>Data 3</td> <td>Optical Interface Data 3</td> </tr> <tr> <td>Data 4</td> <td>Optical Interface Data 4</td> </tr> <tr> <td>DC Input 1-2</td> <td>-48 V_{DC}</td> </tr> <tr> <td>MMI</td> <td>Display - Radio Status</td> </tr> <tr> <td>GND</td> <td>Ground</td> </tr> </tbody> </table>	Port	Description	ANT 1–16	RF Output ports from 1 to 4	Alarm	Alarm	ALD	Antenna Line Device	Data 1	Optical Interface Data 1	Data 2	Optical Interface Data 2	Data 3	Optical Interface Data 3	Data 4	Optical Interface Data 4	DC Input 1-2	-48 V _{DC}	MMI	Display - Radio Status	GND	Ground											
Port	Description																																	
ANT 1–16	RF Output ports from 1 to 4																																	
Alarm	Alarm																																	
ALD	Antenna Line Device																																	
Data 1	Optical Interface Data 1																																	
Data 2	Optical Interface Data 2																																	
Data 3	Optical Interface Data 3																																	
Data 4	Optical Interface Data 4																																	
DC Input 1-2	-48 V _{DC}																																	
MMI	Display - Radio Status																																	
GND	Ground																																	
Physical	<table border="1"> <tbody> <tr> <td>Dimensions</td> <td>398 mm × 494 mm × 316 mm (H × W × D)</td> </tr> <tr> <td>Weight</td> <td>49 kg</td> </tr> <tr> <td>Operating Temperature</td> <td>-40 to +55 °C</td> </tr> <tr> <td>Mounting</td> <td>Pole, Wall, Rail Mount</td> </tr> <tr> <td>Cooling</td> <td>Convection (forced air)</td> </tr> </tbody> </table>	Dimensions	398 mm × 494 mm × 316 mm (H × W × D)	Weight	49 kg	Operating Temperature	-40 to +55 °C	Mounting	Pole, Wall, Rail Mount	Cooling	Convection (forced air)																							
Dimensions	398 mm × 494 mm × 316 mm (H × W × D)																																	
Weight	49 kg																																	
Operating Temperature	-40 to +55 °C																																	
Mounting	Pole, Wall, Rail Mount																																	
Cooling	Convection (forced air)																																	
Software details	CXP9013268%15_R86KC																																	
Radio Hardware Configuration	<table border="1"> <thead> <tr> <th>Product: KRC 161 912/3</th> <th>R1C/A</th> <th>Description</th> </tr> </thead> <tbody> <tr> <td>NTB 101 1912/1</td> <td>R1C</td> <td>Parts</td> </tr> <tr> <td>NTB 101 1913/1</td> <td>R1C</td> <td>Parts</td> </tr> <tr> <td>1/KRC 161 912/3</td> <td>R1C/A</td> <td>Radio Unit (2)</td> </tr> <tr> <td>ROA 128 8480/1</td> <td>R1F</td> <td>Radio PCP</td> </tr> <tr> <td>ROZ 104 8488/1</td> <td>R1C</td> <td>DC-DC Circuit</td> </tr> <tr> <td>ROR 101 8480/25</td> <td>R1D</td> <td>PAM B25 (2)</td> </tr> <tr> <td>ROR 101 8480/66</td> <td>R1B</td> <td>PAM B66 (2)</td> </tr> <tr> <td>KRF 901 591</td> <td>R1A</td> <td>Filter Unit</td> </tr> <tr> <td>NTB 101 1914/1</td> <td>R1C</td> <td>Parts</td> </tr> <tr> <td>...NTB 101 1915/1</td> <td>R1C</td> <td>Parts</td> </tr> </tbody> </table>	Product: KRC 161 912/3	R1C/A	Description	NTB 101 1912/1	R1C	Parts	NTB 101 1913/1	R1C	Parts	1/KRC 161 912/3	R1C/A	Radio Unit (2)	ROA 128 8480/1	R1F	Radio PCP	ROZ 104 8488/1	R1C	DC-DC Circuit	ROR 101 8480/25	R1D	PAM B25 (2)	ROR 101 8480/66	R1B	PAM B66 (2)	KRF 901 591	R1A	Filter Unit	NTB 101 1914/1	R1C	Parts	...NTB 101 1915/1	R1C	Parts
Product: KRC 161 912/3	R1C/A	Description																																
NTB 101 1912/1	R1C	Parts																																
NTB 101 1913/1	R1C	Parts																																
1/KRC 161 912/3	R1C/A	Radio Unit (2)																																
ROA 128 8480/1	R1F	Radio PCP																																
ROZ 104 8488/1	R1C	DC-DC Circuit																																
ROR 101 8480/25	R1D	PAM B25 (2)																																
ROR 101 8480/66	R1B	PAM B66 (2)																																
KRF 901 591	R1A	Filter Unit																																
NTB 101 1914/1	R1C	Parts																																
...NTB 101 1915/1	R1C	Parts																																
Product Identification / Markings and Labels	<p>The image shows two labels for the radio unit. The top label contains the following information: (1P)KRC 161 912/3, (21P)R1C, (S)E23C828735, 20210420, Made in Estonia, and FCC ID: TA8AKRC161912-3, IC: 287AB-AS1619123, AS1619123. Below the labels is a technical drawing of the radio unit with various components labeled with callouts such as 4BVTZTMini ZFA_1, 2.1 Q-1,1, ALD_1, A_1,1Z, A_2,1Z, B_1,1Z, 1.2 Q-2,2, B_2,1Z, A_2,2Z, ALD_2, and 4BVTZTMini ZFA_2.</p>																																	



3.3 EUT test details

EUT setup/configuration rationale for Down link:

RAT	Modulation	Performance Requirement	Test Model / Configuration
LTE/NR	QPSK	N/A	E-TM1.1
LTE/NR	16QAM	N/A	E-TM3.2
LTE/NR	64QAM	N/A	E-TM3.1
LTE/NR	256QAM	N/A	E-TM3.1a
WCDMA	QPSK	N/A	TM1
WCDMA	16QAM	N/A	TM5
WCDMA	64QAM	N/A	TM6
CDMA	QPSK	N/A	TM2
GSM	GMSK	N/A	TM1

LTE Single Carrier B25

Bandwidth, MHz	LTE Transmit / DL, MHz					
	B	EARFCN	M	EARFCN	T	EARFCN
5	1932.5	8065	1962.5	8365	1992.5	8665
10	1935.0	8090	1962.5	8365	1990.0	8640
15	1937.5	8115	1962.5	8365	1987.5	8615
20	1940.0	8140	1962.5	8365	1985.0	8590

Bandwidth, MHz	LTE Receive / UL, MHz					
	B	EARFCN	M	EARFCN	T	EARFCN
5	1852.5	26065	1882.5	26365	1912.5	26665
10	1855.0	26090	1882.5	26365	1910.0	26640
15	1857.5	26115	1882.5	26365	1907.5	26615
20	1860.0	26140	1882.5	26365	1905.0	26590

NR Single Carrier B25

Bandwidth, MHz	Transmit / DL, MHz					
	B	NR-ARFCN	M	NR-ARFCN	T	NR-ARFCN
5	1932.5	386500	1962.5	392500	1992.5	398500
10	1935.0	387000	1962.5	392500	1990.0	398000
15	1937.5	387500	1962.5	392500	1987.5	397500
20	1940.0	388000	1962.5	392500	1985.0	397000

Bandwidth, MHz	Receive / UL, MHz					
	B	NR-ARFCN	M	NR-ARFCN	T	NR-ARFCN
5	1852.5	370500	1882.5	376500	1912.5	382500
10	1855.0	371000	1882.5	376500	1910.0	382000
15	1857.5	371500	1882.5	376500	1907.5	381500
20	1860.0	372000	1882.5	376500	1905.0	381000

WCDMA Single Carrier B2

Bandwidth, MHz	Transmit / DL, MHz					
	B	UARFCN	M	UARFCN	T	UARFCN
5	1932.4	9662	1960	9800	1987.6	9938

Bandwidth, MHz	Receive / UL, MHz					
	B	Channel	M	EARFCN	T	Channel
1.25	1851.250	25	1880.000	600	1908.750	1175

EUT test details, continued

GSM Single Carrier B2

Bandwidth, MHz	Transmit / DL, MHz					
	B	ARFCN	M	ARFCN	T	ARFCN
0.2	1930.2	512	1960	661	1989.8	810

Bandwidth, MHz	Receive / UL, MHz					
	B	ARFCN	M	ARFCN	T	ARFCN
0.2	1850.2	512	1880.0	661	1909.8	810

CDMA Single Carrier B2

Bandwidth, MHz	Transmit / DL, MHz					
	B	Channel	M	Channel	T	Channel
1.25	1931.250	25	1960.000	600	1988.750	1175

Bandwidth, MHz	Receive / UL, MHz					
	B	Channel	M	EARFCN	T	Channel
1.25	1851.250	25	1880.000	600	1908.750	1175

LTE Single Carrier B66

Bandwidth, MHz	LTE Transmit / DL, MHz					
	B	EARFCN	M	EARFCN	T	EARFCN
5	2112.5	66461	2155.0	66886	2197.5	67311
10	2115.0	66486	2155.0	66886	2195.0	67286
15	2117.5	66511	2155.0	66886	2192.5	67261
20	2120.0	66536	2155.0	66886	2190.0	67236

Bandwidth, MHz	LTE Receive / UL, MHz					
	B	EARFCN	M	EARFCN	T	EARFCN
5	1712.5	131997	1745.0	132322	n/a	n/a
10	1715.0	132022	1745.0	132322	n/a	n/a
15	1717.5	132047	1745.0	132322	n/a	n/a
20	1720.0	132072	1745.0	132322	n/a	n/a

NR Single Carrier B66

Bandwidth, MHz	Transmit / DL, MHz					
	B	NR-ARFCN	M	NR-ARFCN	T	NR-ARFCN
5	2112.5	422500	2155.0	431000	2197.5	439500
10	2115.0	423000	2155.0	431000	2195.0	439000
15	2117.5	423500	2155.0	431000	2192.5	438500
20	2120.0	424000	2155.0	431000	2190.0	438000

Bandwidth, MHz	Receive / UL, MHz					
	B	NR-ARFCN	M	NR-ARFCN	T	NR-ARFCN
5	1712.5	342500	1755.0	351000	n/a	n/a
10	1715.0	343000	1755.0	351000	n/a	n/a
15	1717.5	343500	1755.0	351000	n/a	n/a
20	1720.0	344000	1755.0	351000	n/a	n/a



EUT test details, continued

WCDMA Single Carrier B66 (B4 portion)

Bandwidth, MHz	Transmit / DL, MHz					
	B	UARFCN	M	UARFCN	T	UARFCN
5	2112.4	1537	2132.6	1638	2152.6	1738

Bandwidth, MHz	Receive / UL, MHz					
	B	UARFCN	M	UARFCN	T	UARFCN
5	1712.4	1312	1732.6	1413	1752.6	1513

B25 LTE Multiple-Carriers for Band Edge and Spurious Emissions:

Bandwidth, MHz	Transmit / DL, MHz							
	B1	EARFCN	B2	EARFCN	T2	EARFCN	T1	EARFCN
10	1935.0	8090	1945.0	8190	1980.0	8540	1990.0	8640

Bandwidth, MHz	Receive / UL, MHz							
	B1	EARFCN	B2	EARFCN	T2	EARFCN	T1	EARFCN
10	1855.0	26090	1865.0	26190	1900.0	26540	1910.0	26640

B25 LTE Multiple-Carriers for Band Edge and Spurious Emissions:

Bandwidth, MHz	Transmit / DL, MHz											
	B1	EARFCN	B2	EARFCN	B3	EARFCN	T3	EARFCN	T2	EARFCN	T1	EARFCN
10	1935.0	8090	1945.0	8190	1955.0	8290	1970.0	8440	1980.0	8540	1990.0	8640

Bandwidth, MHz	Receive / UL, MHz											
	B1	EARFCN	B2	EARFCN	B3	EARFCN	T3	EARFCN	T2	EARFCN	T1	EARFCN
10	1855.0	26090	1865.0	26190	1875.0	26290	1890.0	26440	1900.0	26540	1910.0	26640

B25 LTE Multiple-Carriers for Band Edge and Spurious Emissions:

Bandwidth, MHz	Transmit / DL, MHz							
	B1	B2	B3	B4	T4	T3	T2	T1
5	1932.5	1937.5	1942.5	1947.5	1977.5	1982.5	1987.5	1992.5

Bandwidth, MHz	Receive / UL, MHz							
	B1	B2	B3	B4	T4	T3	T2	T1
5	1852.5	1857.5	1862.5	1867.5	1897.5	1902.5	1907.5	1912.5

B25 NR Multiple-Carriers for Band Edge and Spurious Emissions:

Bandwidth, MHz	Transmit / DL, MHz							
	B1	NR-ARFCN	B2	NR-ARFCN	T2	NR-ARFCN	T1	NR-ARFCN
10	1935.0	387000	1945.0	389000	1980.0	396000	1990.0	398000

Bandwidth, MHz	Receive / UL, MHz							
	B1	NR-ARFCN	B2	NR-ARFCN	T2	NR-ARFCN	T1	NR-ARFCN
10	1855.0	371000	1865.0	1855.0	1900.0	380000	1910.0	382000

EUT test details, continued

B25 NR Multiple-Carriers for Band Edge and Spurious Emissions:

Bandwidth, MHz	Transmit / DL, MHz												
	B1	NR-ARFCN	B2	NR-ARFCN	B3	NR-ARFCN		T3	NR-ARFCN	T2	NR-ARFCN	T1	NR-ARFCN
10	1935.0	387000	1945.0	389000	1955.0	391000		1970.0	394000	1980.0	396000	1990.0	398000

Bandwidth, MHz	Receive / UL, MHz												
	B1	NR-ARFCN	B2	NR-ARFCN	B3	NR-ARFCN		T3	NR-ARFCN	T2	NR-ARFCN	T1	NR-ARFCN
10	1855.0	371000	1865.0	373000	1875.0	375000		1890.0	378000	1900.0	380000	1910.0	382000

B25 NR Multiple-Carriers for Band Edge and Spurious Emissions:

Bandwidth, MHz	Transmit / DL, MHz									
	B1	B2	B3	B4		T4	T3	T2	T1	
5	1932.5	1937.5	1942.5	1947.5		1977.5	1982.5	1987.5	1992.5	

Bandwidth, MHz	Receive / UL, MHz									
	B1	B2	B3	B4		T4	T3	T2	T1	
5	1852.5	1857.5	1862.5	1867.5		1897.5	1902.5	1907.5	1912.5	

B66 LTE Multiple-Carriers for Band Edge and Spurious Emissions:

Bandwidth, MHz	Transmit / DL, MHz									
	B1	EARFCN	B2	EARFCN		T2	EARFCN	T1	EARFCN	
10	2115.0	66486	2125.0	66586		2185.0	67186	2195.0	67286	

Bandwidth, MHz	Receive / UL, MHz									
	B1	EARFCN	B2	EARFCN		T2	EARFCN	T1	EARFCN	
10	1715.0	132022	1725.0	132122		n/a	n/a	n/a	n/a	

B66 LTE Multiple-Carriers for Band Edge and Spurious Emissions:

Bandwidth, MHz	Transmit / DL, MHz												
	B1	EARFCN	B2	EARFCN	B3	EARFCN		T3	EARFCN	T2	EARFCN	T1	EARFCN
10	2115.0	66486	2125.0	66586	2135.0	66686		2175.0	67086	2185.0	67186	2195.0	67286

Bandwidth, MHz	Receive / UL, MHz												
	B1	EARFCN	B2	EARFCN	B3	EARFCN		T3	EARFCN	T2	EARFCN	T1	EARFCN
10	1715.0	132022	1725.0	132122	1735.0	132122		1775.0	132622	n/a	n/a	n/a	n/a

B66 LTE Multiple-Carriers for Band Edge and Spurious Emissions:

Bandwidth, MHz	Transmit / DL, MHz									
	B1	B2	B3	B4		T4	T3	T2	T1	
5	2112.5	2117.5	2122.5	2127.5		2182.5	2187.5	2192.5	2197.5	

Bandwidth, MHz	Receive / UL, MHz									
	B1	B2	B3	B4		T4	T3	T2	T1	
5	1712.5	1717.5	1722.5	1727.5		n/a	n/a	n/a	n/a	



EUT test details, continued

B66 NR Multiple-Carriers for Band Edge and Spurious Emissions:

Bandwidth, MHz	Transmit / DL, MHz							
	B1	NR-ARFCN	B2	NR-ARFCN	T2	NR-ARFCN	T1	NR-ARFCN
10	2115.0	423000	2125.0	425000	2185.0	437000	2195.0	439000

Bandwidth, MHz	Receive / UL, MHz							
	B1	NR-ARFCN	B2	NR-ARFCN	T2	NR-ARFCN	T1	NR-ARFCN
10	1715.0	343000	1725.0	345000	n/a	n/a	n/a	n/a

B66 NR Multiple-Carriers for Band Edge and Spurious Emissions:

Bandwidth, MHz	Transmit / DL, MHz											
	B1	EARFCN	B2	EARFCN	B3	EARFCN	T3	EARFCN	T2	EARFCN	T1	EARFCN
10	2115.0	423000	2125.0	425000	2135.0	427000	2175.0	435000	2185.0	437000	2195.0	439000

Bandwidth, MHz	Receive / UL, MHz											
	B1	EARFCN	B2	EARFCN	B3	EARFCN	T3	EARFCN	T2	EARFCN	T1	EARFCN
10	1715.0	343000	1725.0	345000	1735.0	347000	1775.0	355000	n/a	n/a	n/a	n/a

B66 NR Multiple-Carriers for Band Edge and Spurious Emissions:

Bandwidth, MHz	Transmit / DL, MHz							
	B1	B2	B3	B4	T4	T3	T2	T1
5	2112.5	2117.5	2122.5	2127.5	2182.5	2187.5	2192.5	2197.5

Bandwidth, MHz	Receive / UL, MHz							
	B1	B2	B3	B4	T4	T3	T2	T1
5	1712.5	1717.5	1722.5	1727.5	n/a	n/a	n/a	n/a

B25 LTE Multiple-Carriers for spurious emissions (IBW=65MHz):

Bandwidth (MHz)	Transmit / DL (MHz)			
	C1	EARFCN	C2	EARFCN
10	1935.0	8090	1990.0	8640
15	1937.5	8115	1987.5	8615
20	1940.0	8140	1985.0	8590
10	1957.5	8315	1967.5	8415

Bandwidth (MHz)	Receive / UL (MHz)			
	C1	EARFCN	C2	EARFCN
10	1855.0	26090	1910.0	26640
15	1857.5	26115	1907.5	26615
20	1860.0	26140	1905.0	26590
10	1877.5	26315	1887.5	26415

EUT test details, continued

B25 LTE Multiple-Carriers for spurious emissions (IBW=65MHz):

Bandwidth (MHz)	Transmit / DL (MHz)					
	C1	EARFCN	C2	EARFCN	C3	EARFCN
10	1935.0	8090	1945.0	8190	1990.0	8640
15	1937.5	8115	1952.5	8265	1987.5	8615
20	1940.0	8140	1960.0	8340	1985.0	8590
10	1952.5	8265	1962.5	8365	1972.5	8465

Bandwidth (MHz)	Receive / UL (MHz)					
	C1	EARFCN	C2	EARFCN	C3	EARFCN
10	1855.0	26090	1865.0	26190	1910.0	26640
15	1857.5	26115	1872.5	26265	1907.5	26615
20	1860.0	26140	1880.0	26340	1905.0	26590
10	1872.5	26265	1882.5	26365	1892.5	26465

B25 LTE Multiple-Carriers for spurious emissions (IBW=65MHz):

Bandwidth (MHz)	Transmit / DL (MHz)							
	C1	EARFCN	C2	EARFCN	C3	EARFCN	C4	EARFCN
5	1932.5	8065	1937.5	8115	1962.5	8365	1992.5	8665
5	1955.0	8290	1960.0	8340	1965.0	8390	1970.0	8440

Bandwidth (MHz)	Receive / UL (MHz)							
	C1	EARFCN	C2	EARFCN	C3	EARFCN	C4	EARFCN
5	1852.5	26065	1857.5	26115	1882.5	26365	1912.5	26665
5	1875.0	26290	1880.0	26340	1885.0	26390	1890.0	26440

B25 NR Multiple-Carriers for spurious emissions (IBW=65MHz):

Bandwidth (MHz)	Transmit / DL (MHz)			
	C1	NR-ARFCN	C2	NR-ARFCN
10	1935.0	387000	1990.0	398000
15	1937.5	387500	1987.5	397500
20	1940.0	388000	1985.0	397000
10	1957.5	391500	1967.5	393500

Bandwidth (MHz)	Receive / UL (MHz)			
	C1	NR-ARFCN	C2	NR-ARFCN
10	1855.0	371000	1910.0	382000
15	1857.5	371500	1907.5	381500
20	1860.0	372000	1905.0	381000
10	1877.5	375500	1887.5	377500

B25 NR Multiple-Carriers for spurious emissions (IBW=65MHz):

Bandwidth (MHz)	Transmit / DL (MHz)					
	C1	NR-ARFCN	C2	NR-ARFCN	C3	NR-ARFCN
10	1935.0	387000	1945.0	389000	1990.0	398000
15	1937.5	387500	1952.5	390500	1987.5	397500
20	1940.0	388000	1960.0	392000	1985.0	397000
10	1952.5	390500	1962.5	392500	1972.5	394500

Bandwidth (MHz)	Receive / UL (MHz)					
	C1	NR-ARFCN	C2	NR-ARFCN	C3	NR-ARFCN
10	1855.0	371000	1865.0	373000	1910.0	382000
15	1857.5	371500	1872.5	374500	1907.5	381500
20	1860.0	372000	1880.0	376000	1905.0	381000
10	1872.5	374500	1882.5	376500	1892.5	378500

EUT test details, continued

B25 NR Multiple-Carriers for spurious emissions (IBW=65MHz):

Bandwidth (MHz)	Transmit / DL (MHz)							
	C1	NR-ARFCN	C2	NR-ARFCN	C3	NR-ARFCN	C4	NR-ARFCN
5	1932.5	386500	1937.5	387500	1962.5	392500	1992.5	398500
5	1955	391000	1960	392000	1965	393000	1970	394000

Bandwidth (MHz)	Receive / UL (MHz)							
	C1	NR-ARFCN	C2	NR-ARFCN	C3	NR-ARFCN	C4	NR-ARFCN
5	1852.5	370500	1857.5	371500	1882.5	376500	1912.5	382500
5	1875.0	375000	1880.0	376000	1885.0	377000	1890.0	378000

B66 LTE Multiple-Carriers for spurious emissions (IBW=90MHz)

Bandwidth (MHz)	Transmit / DL (MHz)			
	C1	EARFCN	C2	EARFCN
10	2115.0	66486	2175.0	67086
15	2117.5	66511	2172.5	67061
20	2120.0	66536	2170.0	67036
10	2150.0	66836	2160.0	66936

Bandwidth (MHz)	Receive / UL (MHz)			
	C1	EARFCN	C2	EARFCN
5	1712.5	131997	n/a	n/a
10	1715.0	132022	n/a	n/a
15	1717.5	132047	n/a	n/a
20	1720.0	132072	n/a	n/a
10	1750.0	132372	1760.0	132472

B66 LTE Multiple-Carriers for spurious emissions (IBW=90MHz):

Bandwidth (MHz)	Transmit / DL (MHz)					
	C1	EARFCN	C2	EARFCN	C3	EARFCN
10	2115.0	66486	2125.0	66586	2195.0	67286
15	2117.5	66511	2132.5	66661	2192.5	67261
20	2120.0	66536	2140.0	66736	2190.0	67236
10	2145.0	66786	2155.0	66886	2165.0	66986

Bandwidth (MHz)	Receive / UL (MHz)					
	C1	EARFCN	C2	EARFCN	C3	EARFCN
10	1715.0	132022	1725.0	132122	n/a	n/a
15	1717.5	132047	1732.5	132197	n/a	n/a
20	1720.0	132072	1740.0	132272	n/a	n/a
10	1745.0	132322	1755.0	132422	1765.0	132522

EUT test details, continued

B66 LTE Multiple-Carriers for spurious emissions (IBW=90MHz):

Bandwidth (MHz)	Transmit / DL (MHz)							
	C1	EARFCN	C2	EARFCN	C3	EARFCN	C4	EARFCN
5	2112.5	66461	2117.5	66511	2155.0	66886	2197.5	67311
5	2147.5	66811	2152.5	66861	2157.5	66911	2162.5	66961

Bandwidth (MHz)	Receive / UL (MHz)							
	C1	EARFCN	C2	EARFCN	C3	EARFCN	C4	EARFCN
5	1712.5	131997	1717.5	132047	1755.0	132422	n/a	n/a
5	1747.5	132347	1752.5	132397	1757.5	132447	1762.5	132497

B66 NR Multiple-Carriers for spurious emissions (IBW=90MHz):

Bandwidth (MHz)	Transmit / DL (MHz)			
	C1	NR-ARFCN	C2	NR-ARFCN
10	2115.0	423000	2195.0	439000
15	2117.5	423500	2192.5	438500
20	2120.0	424000	2190.0	438000
10	2150.0	430000	2160.0	432000

Bandwidth (MHz)	Receive / UL (MHz)			
	C1	NR-ARFCN	C2	NR-ARFCN
10	1715.0	343000	n/a	n/a
15	1717.5	343500	n/a	n/a
20	1720.0	344000	n/a	n/a
10	1750.0	350000	1760.0	352000

B66 NR Multiple-Carriers for spurious emissions (IBW=90MHz):

Bandwidth (MHz)	Transmit / DL (MHz)					
	C1	NR-ARFCN	C2	NR-ARFCN	C3	NR-ARFCN
10	2115.0	423000	2125.0	425000	2195.0	439000
15	2117.5	423500	2132.5	426500	2192.5	438500
20	2120.0	424000	2140.0	428000	2190.0	438000
10	2145.0	429000	2155.0	431000	2165.0	433000

Bandwidth (MHz)	Receive / UL (MHz)					
	C1	NR-ARFCN	C2	NR-ARFCN	C3	NR-ARFCN
10	1715.0	343000	1725.0	345000	n/a	n/a
15	1717.5	343500	1732.5	346500	n/a	n/a
20	1720.0	344000	1740.0	348000	n/a	n/a
10	1745.0	349000	1755.0	351000	1765.0	353000

B66 NR Multiple-Carriers for spurious emissions (IBW=90MHz):

Bandwidth (MHz)	Transmit / DL (MHz)							
	C1	NR-ARFCN	C2	NR-ARFCN	C3	NR-ARFCN	C4	NR-ARFCN
5	2112.5	422500	2117.5	423500	2155.0	431000	2197.5	439500
5	2147.5	429500	2152.5	430500	2157.5	431500	2162.5	432500

Bandwidth (MHz)	Receive / UL (MHz)							
	C1	NR-ARFCN	C2	NR-ARFCN	C3	NR-ARFCN	C4	NR-ARFCN
5	1712.5	342500	1717.5	343500	1755.0	351000	n/a	n/a
5	1747.5	349500	1752.5	350500	1757.5	351500	1762.5	352500

EUT test details, continued

B25 Mixed Mode (WCDMA with LTE/NR/GSM) for Band Edge and/or Spurious Emissions:

Carrier configurations	Transmit / DL, MHz
2C, WCDMA + LTE 15MHz, Bottom	1932.4(W) + 1942.4(L15)
2C, WCDMA + LTE 15MHz, Middle	1960(W) + 1970(L15)
2C, WCDMA + NR 15MHz, Bottom	1932.4(W) + 1942.4(N15)
2C, WCDMA + NR 15MHz, Middle	1960(W) + 1970(N15)
2C, WCDMA + GSM, Bottom	1932.4(W) + 1935(G)
2C, WCDMA + GSM, Middle	1960(W) + 1962.6(G)
2C, GSM + WCDMA, Top	1985(G) + 1987.6(W)
3C, WCDMA + LTE 10MHz + NR 5MHz, Bottom	1932.4(W) + 1940(L10) + 1947.5(N5)
3C, WCDMA + LTE 10MHz + NR 5MHz, Middle	1960(W) + 1967.5(L10) + 1975(N5)
3C, WCDMA + NR 10MHz + LTE 5MHz, Bottom	1932.4(W) + 1940(N10) + 1947.5(L5)
3C, WCDMA + NR 10MHz + LTE 5MHz, Middle	1960(W) + 1967.5(N10) + 1975(L5)
6C, WCDMA + 4 x NR 5MHz + LTE 5MHz, Bottom	1932.4(W) + 1937.5(N5) + 1942.5(N5) + 1947.5(N5) + 1952.5(N5) + 1957.5(L5)
6C, WCDMA + 4 x NR 5MHz + LTE 5MHz, Middle	1960(W) + 1965(N5) + 1970(N5) + 1975(N5) + 1980(N5) + 1985(L5)

B25 Mixed Mode (CDMA with LTE/NR) for Band Edge and/or Spurious Emissions:

Carrier configurations	Transmit / DL, MHz
2C, CDMA + LTE 15MHz, Bottom	1931.25(C) + 1939.4(L15)
2C, CDMA + LTE 15MHz, Middle	1960(C) + 1968.1(L15)
2C, CDMA + NR 15MHz, Bottom	1931.25(C) + 1939.4(N15)
2C, CDMA + NR 15MHz, Middle	1960(C) + 1968.1(N15)
3C, CDMA + LTE 10MHz + NR 5MHz, Bottom	1931.25(C) + 1936.9(L10) + 1944.4(N5)
3C, CDMA + LTE 10MHz + NR 5MHz, Middle	1960(C) + 1965.7(L10) + 1973.2(N5)
3C, CDMA + NR 10MHz + LTE 5MHz, Bottom	1931.25(C) + 1936.9(N10) + 1944.4(L5)
3C, CDMA + NR 10MHz + LTE 5MHz, Middle	1960(C) + 1965.7(N10) + 1973.2(L5)
6C, CDMA + 4 x NR 5MHz + LTE 5MHz, Bottom	1931.25(C) + 1934.4(N5) + 1939.4(N5) + 1944.4(N5) + 1949.4(N5) + 1954.4(L5)
6C, CDMA + 4 x NR 5MHz + LTE 5MHz, Middle	1960(C) + 1963.1(N5) + 1968.1(N5) + 1973.1(N5) + 1978.1(N5) + 1983.1(L5)

B25 Mixed Mode (GSM with LTE/NR/WCDMA) for Band Edge and/or Spurious Emissions:

Carrier configurations	Transmit / DL, MHz
2C, GSM + LTE 15MHz, Bottom	1930.2(G) + 1937.8(L15)
2C, GSM + LTE 15MHz, Middle	1960(G) + 1967.5(L15)
2C, GSM + NR 15MHz, Bottom	1930.2(G) + 1937.8(N15)
2C, GSM + NR 15MHz, Middle	1960(G) + 1967.5(N15)
2C, GSM + WCDMA, Bottom	1930.2(G) + 1932.8(W)
2C, GSM + WCDMA, Middle	1960(G) + 1962.6(W)
2C, WCDMA + GSM, Top	1987.2(W) + 1989.8(G)
3C, GSM + LTE 10MHz + NR 5MHz, Bottom	1930.2(G) + 1935.3(L10) + 1942.8(N5)
3C, GSM + LTE 10MHz + NR 5MHz, Middle	1960(G) + 1965.1(L10) + 1972.6(N5)
3C, GSM + NR 10MHz + LTE 5MHz, Bottom	1930.2(G) + 1935.3(N10) + 1942.8(L5)
3C, GSM + NR 10MHz + LTE 5MHz, Middle	1960(G) + 1965.1(N10) + 1972.6(L5)
6C, GSM + 4 x NR 5MHz + LTE 5MHz, Bottom	1930.2(G) + 1932.8(N5) + 1937.8(N5) + 1942.8(N5) + 1947.8(N5) + 1952.8(L5)
6C, GSM + 4 x NR 5MHz + LTE 5MHz, Middle	1960(G) + 1962.6(N5) + 1967.6(N5) + 1972.6(N5) + 1977.6(N5) + 1982.6(L5)

EUT test details, continued

B25 Mixed Mode (LTE with NR/WCDMA/CDMA/GSM) for Band Edge and/or Spurious Emissions:

Carrier configurations	Transmit / DL, MHz
2C, LTE 15MHz + NR 5MHz, Bottom	1937.5(L15) + 1947.5(N5)
2C, LTE 15MHz + NR 5MHz, Middle	1962.5(L15) + 1972.5(N5)
2C, NR 5MHz + LTE 15MHz, Top	1977.5(N5) + 1987.5(L15)
2C, LTE 15MHz + WCDMA, Bottom	1937.5(L15) + 1947.4(W)
2C, WCDMA + LTE 15MHz, Top	1977.6(W) + 1987.5(L15)
2C, LTE 15MHz + CDMA, Bottom	1937.5(L15) + 1945.65(C)
2C, CDMA + LTE 15MHz, Top	1979.35(C) + 1987.5(L15)
2C, LTE 15MHz + GSM, Bottom	1937.5(L15) + 1945.2(G)
2C, GSM + LTE 15MHz, Top	1979.8(G) + 1987.5(L15)
3C, LTE 10MHz + GSM + NR 5MHz, Bottom	1935(L10) + 1940.2(G) + 1942.8(N5)
3C, NR 5MHz + GSM + LTE 10MHz, Top	1982.2(N5) + 1984.8(G) + 1990(L10)
3C, LTE 10MHz + WCDMA + NR 5MHz, Bottom	1935(L10) + 1942.4(W) + 1947.5(N5)
3C, NR 5MHz + WCDMA + LTE 10MHz, Top	1977.5(N5) + 1982.6(W) + 1990(L10)
3C, LTE 10MHz + CDMA + NR 5MHz, Bottom	1935(L10) + 1940.65(C) + 1943.8(N5)
3C, NR 5MHz + CDMA + LTE 10MHz, Top	1981.2(N5) + 1984.35(C) + 1990(L10)
3C, NR 10MHz + WCDMA + LTE 5MHz, Top	1980(N10) + 1987.6(W) + 1992.5(L5)
3C, NR 10MHz + CDMA + LTE 5MHz, Top	1983.1(N10) + 1988.75(C) + 1992.5(L5)
3C, NR 10MHz + GSM + LTE 5MHz, Top	1984.7(N10) + 1989.8(G) + 1992.5(L5)
6C, LTE 5MHz + WCDMA + 4 x NR 5MHz, Bottom	1932.5(L5) + 1937.4(W) + 1942.5(N5) + 1947.5(N5) + 1952.5(N5) + 1957.5(N5)
6C, 4 x NR 5MHz + WCDMA + LTE 5MHz, Top	1967.5(N5) + 1972.5(N5) + 1977.5(N5) + 1982.5(N5) + 1987.6(W) + 1992.5(L5)
6C, LTE 5MHz + CDMA + 4 x NR 5MHz, Bottom	1932.5(L5) + 1935.65(C) + 1938.8(N5) + 1943.8(N5) + 1948.8(N5) + 1953.8(N5)
6C, 4 x NR 5MHz + CDMA + LTE 5MHz, Top	1970.6(N5) + 1975.6(N5) + 1980.6(N5) + 1985.6(N5) + 1988.75(C) + 1992.5(L5)
6C, LTE 5MHz + GSM + 4 x NR 5MHz, Bottom	1932.5(L5) + 1935.2(G) + 1937.8(N5) + 1942.8(N5) + 1947.8(N5) + 1952.8(N5)
6C, 4 x NR 5MHz + GSM + LTE 5MHz, Top	1972.2(N5) + 1977.2(N5) + 1982.2(N5) + 1987.2(N5) + 1989.8(G) + 1992.5(L5)

B25 Mixed Mode (NR with LTE/WCDMA/CDMA/GSM) for Band Edge and/or Spurious Emissions:

Carrier configurations	Transmit / DL, MHz
2C, NR 15MHz + LTE 5MHz, Bottom	1937.5(N15) + 1947.5(L5)
2C, NR 15MHz + LTE 5MHz, Middle	1962.5(N15) + 1972.5(L5)
2C, LTE 5MHz + NR 15MHz, Top	1977.5(L5) + 1987.5(N15)
2C, NR 15MHz + WCDMA, Bottom	1937.5(N15) + 1947.4(W)
2C, WCDMA + NR 15MHz, Top	1977.6(W) + 1987.5(N15)
2C, NR 15MHz + CDMA, Bottom	1937.5(N15) + 1945.65(C)
2C, CDMA + NR 15MHz, Top	1979.35(C) + 1987.5(N15)
2C, NR 15MHz + GSM, Bottom	1937.5(N15) + 1945.2(G)
2C, GSM + NR 15MHz, Top	1979.8(G) + 1987.5(N15)
3C, NR 10MHz + GSM + LTE 5MHz, Bottom	1935(N10) + 1940.2(G) + 1942.8(L5)
3C, LTE 5MHz + GSM + NR 10MHz, Top	1982.2(L5) + 1984.8(G) + 1990(N10)
3C, NR 10MHz + WCDMA + LTE 5MHz, Bottom	1935(N10) + 1942.4(W) + 1947.5(L5)
3C, LTE 5MHz + WCDMA + NR 10MHz, Top	1977.5(L5) + 1982.6(W) + 1990(N10)
3C, NR 10MHz + CDMA + LTE 5MHz, Bottom	1935(N10) + 1940.65(C) + 1943.8(L5)
3C, LTE 5MHz + CDMA + NR 10MHz, Top	1981.2(L5) + 1984.35(C) + 1990(N10)
3C, LTE 10MHz + WCDMA + NR 5MHz, Top	1980(L10) + 1987.6(W) + 1992.5(N5)
3C, LTE 10MHz + CDMA + NR 5MHz, Top	1983.1(L10) + 1988.75(C) + 1992.5(N5)
3C, LTE 10MHz + GSM + NR 5MHz, Top	1984.7(L10) + 1989.8(G) + 1992.5(N5)
6C, NR 5MHz + WCDMA + 3 x NR 5MHz + LTE 5MHz, Bottom	1932.5(N5) + 1947.4(W) + 1942.5(N5) + 1947.5(N5) + 1952.5(N5) + 1957.5(L5)
6C, LTE 5MHz + 3 x NR 5MHz + WCDMA + NR 5MHz, Top	1967.5(L5) + 1972.5(N5) + 1977.5(N5) + 1982.5(N5) + 1987.6(W) + 1992.5(N5)
6C, NR 5MHz + CDMA + 3 x NR 5MHz + LTE 5MHz, Bottom	1932.5(N5) + 1935.65(C) + 1938.8(N5) + 1943.8(N5) + 1948.8(N5) + 1953.8(L5)
6C, LTE 5MHz + 3 NR 5MHz + CDMA + NR 5MHz, Top	1970.6(L5) + 1975.6(N5) + 1980.6(N5) + 1985.6(N5) + 1988.75(C) + 1992.5(N5)
6C, NR 5MHz + GSM + 3 x NR 5MHz + LTE 5MHz, Bottom	1932.5(N5) + 1935.2(G) + 1937.8(N5) + 1942.8(N5) + 1947.8(N5) + 1952.8(L5)
6C, LTE 5MHz + 3 NR 5MHz + GSM + NR 5MHz, Top	1972.2(L5) + 1977.2(N5) + 1982.2(N5) + 1987.2(N5) + 1989.8(G) + 1992.5(N5)

EUT test details, continued

B66 Mixed Mode (WCDMA with LTE/NR) for Band Edge and/or Spurious Emissions:

Carrier configurations	Transmit / DL, MHz
2C, WCDMA + LTE 15MHz, Bottom	2112.4(W) + 2122.5(L15)
2C, WCDMA + NR 15MHz, Bottom	2112.4(W) + 2122.5(N15)
3C, WCDMA + LTE 10MHz + NR 5MHz, Bottom	2112.4(W) + 2120(L10) + 2127.5(N5)
3C, WCDMA + NR 10MHz + LTE 5MHz, Bottom	2112.4(W) + 2120(N10) + 2127.5(L5)
6C, WCDMA + 4 x LTE 5MHz + NR 5MHz, Bottom	2112.4(W) + 2117.5(L5) + 2122.5(L5) + 2127.5(L5) + 2132.5(L5) + 2137.5(N5)
6C, WCDMA + 4 x LTE 5MHz + NR 5MHz, Middle	2152.6(W) + 2157.5(L5) + 2162.5(L5) + 2167.5(L5) + 2172.5(L5) + 2177.5(N5)

B66 Mixed Mode (LTE with NR/WCDMA) for Band Edge and/or Spurious Emissions:

Carrier configurations	Transmit / DL, MHz
2C, LTE 15MHz + NR 5MHz, Bottom	2117.5(L15) + 2127.5(N5)
2C, LTE 15MHz + NR 5MHz, Middle	2155(L15) + 2165(N5)
2C, NR 5MHz + LTE 15MHz, Top	2182.5(N5) + 2192.5(L15)
2C, LTE 15MHz + WCDMA, Bottom	2117.5(L15) + 2127.4(W)
2C, WCDMA + LTE 15MHz, Middle	2145(W) + 2155(L15)
2C, WCDMA + LTE 15MHz, Top	2152.6(W) + 2192.5(L15)
3C, LTE 10MHz + NR 5MHz + WCDMA, Bottom	2115(L10) + 2122.5(N5) + 2127.4(W)
3C, WCDMA + LTE 10MHz + NR 5MHz, Middle	2147.4(W) + 2155(L10) + 2162.5(N5)
3C, WCDMA + NR 5MHz + LTE 10MHz, Top	2147.4(W) + 2187.5(N5) + 2195(L10)
6C, 4 LTE 5MHz + WCDMA + NR 5MHz, Bottom	2112.5(L5) + 2117.5(L5) + 2122.5(L5) + 2127.5(L5) + 2132.4(W) + 2137.5(N5)
6C, WCDMA + NR 5MHz + 4 LTE 5MHz, Top	2152.6(W) + 2177.5(N5) + 2182.5(L5) + 2187.5(L5) + 2192.5(L5) + 2197.5(L5)

B66 Mixed Mode (NR with LTE/WCDMA) for Band Edge and/or Spurious Emissions:

Carrier configurations	Transmit / DL, MHz
2C, NR 15MHz + LTE 5MHz, Bottom	2117.5(N15) + 2127.5(L5)
2C, NR 15MHz + LTE 5MHz, Middle	2155(N15) + 2165(L5)
2C, LTE 5MHz + NR 15MHz, Top	2182.5(L5) + 2192.5(N15)
2C, NR 15MHz + WCDMA, Bottom	2117.5(N15) + 2127.4(W)
2C, WCDMA + NR 15MHz, Middle	2145(W) + 2155(N15)
2C, WCDMA + NR 15MHz, Top	2152.6(W) + 2192.5(N15)
3C, NR 10MHz + LTE 5MHz + WCDMA, Bottom	2115(N10) + 2122.5(L5) + 2127.4(W)
3C, WCDMA + NR 10MHz + LTE 5MHz, Middle	2147.4(W) + 2155(N10) + 2162.5(L5)
3C, WCDMA + LTE 5MHz + NR 10MHz, Top	2147.4(W) + 2187.5(L5) + 2195(N10)
6C, NR 5MHz + WCDMA + 4 x LTE 5MHz, Bottom	2112.5(N5) + 2117.4(W) + 2122.5(L5) + 2127.5(L5) + 2132.5(L5) + 2137.5(L5)
6C, WCDMA + 4 x LTE 5MHz + NR 5MHz, Top	2152.6(W) + 2177.5(L5) + 2182.5(L5) + 2187.5(L5) + 2192.5(L5) + 2197.5(N5)

EUT test details, continued

B25 Mixed Mode for Spurious Emissions (IBW=65MHz):

Carrier configurations	Transmit / DL, MHz
2C, LTE 10MHz Bottom + NR 10MHz Top	1935(L10) + 1990(N10)
2C, LTE 15MHz Bottom + GSM Top	1937.5(L15) + 1989.8(G)
2C, GSM Bottom + LTE 15MHz Top	1930.2(G) + 1987.5(L15)
2C, GSM Middle + LTE 15MHz Top	1960(G) + 1987.5(L15)
2C, NR 15MHz Bottom + GSM Top	1937.5(N15) + 1989.8(G)
2C, GSM Bottom + NR 15MHz Top	1930.2(G) + 1987.5(N15)
2C, GSM Middle + NR 15MHz Top	1960(G) + 1987.5(N15)
2C, WCDMA Bottom + LTE 15MHz Top	1932.4(W) + 1987.5(L15)
2C, WCDMA Bottom + NR 15MHz Top	1932.4(W) + 1987.5(N15)
2C, CDMA Bottom + LTE 15MHz Top	1931.25(C) + 1987.5(L15)
2C, CDMA Bottom + NR 15MHz Top	1931.25(C) + 1987.5(N15)
2C, GSM Bottom + WCDMA Top	1930.2(G) + 1987.6(W)
3C, LTE 10MHz Bottom + WCDMA Top + NR 5MHz Top	1935(L10) + 1987.6(W) + 1992.5(N5)
3C, LTE 10MHz Bottom + CDMA Top + NR 5MHz Top	1935(L10) + 1988.75(C) + 1992.5(N5)
3C, LTE 10MHz Bottom + GSM Top + NR 5MHz Top	1935(L10) + 1989.8(G) + 1992.5(N5)
3C, NR 10MHz Bottom + WCDMA Top + LTE 5MHz Top	1935(N10) + 1987.6(W) + 1992.5(L5)
3C, NR 10MHz Bottom + CDMA Top + LTE 5MHz Top	1935(N10) + 1988.75(C) + 1992.5(L5)
3C, NR 10MHz Bottom + GSM Top + LTE 5MHz Top	1935(N10) + 1989.8(G) + 1992.5(L5)
6C, GSM Bottom + LTE 20MHz Bottom + NR 5MHz Middle + NR 10MHz Top + LTE 5MHz Top + NR 5MHz Top	1930.2(G) + 1940.3(L20) + 1962.5(N5) + 1980(N10) + 1987.5(L5) + 1992.5(N5)
6C, WCDMA Bottom + LTE 15MHz Bottom + NR 5MHz Middle + NR 10MHz Top + LTE 5MHz Top + NR 5MHz Top	1932.4(W) + 1942.5(L15) + 1962.5(N5) + 1980(N10) + 1987.5(L5) + 1992.5(N5)
6C, CDMA Bottom + LTE 15MHz Bottom + NR 5MHz Middle + NR 10MHz Top + LTE 5MHz Top + NR 5MHz Top	1931.25(C) + 1939.4(L15) + 1962.5(N5) + 1980(N10) + 1987.5(L5) + 1992.5(N5)
6C, WCDMA Bottom + LTE 5MHz Middle + 4 x NR 5MHz Top	1932.4(W) + 1962.5(L5) + 1977.5(N5) + 1982.5(N5) + 1987.5(N5) + 1992.5(N5)
6C, CDMA Bottom + LTE 5MHz Middle + 4 x NR 5MHz Top	1931.25(C) + 1962.5(L5) + 1977.5(N5) + 1982.5(N5) + 1987.5(N5) + 1992.5(N5)
6C, GSM Bottom + LTE 5MHz Middle + 4 x NR 5MHz Top	1930.2(G) + 1962.5(L5) + 1977.5(N5) + 1982.5(N5) + 1987.5(N5) + 1992.5(N5)

B66 Mixed Mode for Spurious Emissions (IBW=90MHz):

Carrier configurations	Transmit / DL, MHz
2C, LTE 10MHz Bottom + NR 10MHz Top	2115(L10) + 2195(N10)
2C, WCDMA Bottom + LTE 15MHz Top	2112.4(W) + 2192.5(L15)
2C, WCDMA Bottom + NR 15MHz Top	2112.4(W) + 2192.5(N15)
3C, LTE 10MHz Bottom + WCDMA Middle + NR 5MHz Top	2115(L10) + 2152.6(W) + 2197.5(N5)
3C, LTE 5MHz Bottom + WCDMA Middle + NR 10MHz Top	2112.5(L5) + 2152.6(W) + 2195(N10)
6C, WCDMA Bottom + LTE 15MHz Bottom + NR 5MHz Middle + NR 10MHz Top + LTE 5MHz Top + NR 5MHz Top	2112.4(W) + 2122.5(L15) + 2155(N5) + 2185(N10) + 2192.5(L5) + 2197.5(N5)
6C, WCDMA Bottom + NR 5MHz Middle + 4 x LET 5MHz Top	2112.4(W) + 2155(N5) + 2182.5(L5) + 2187.5(L5) + 2192.5(L5) + 2197.5(L5)

3.4 EUT setup diagram

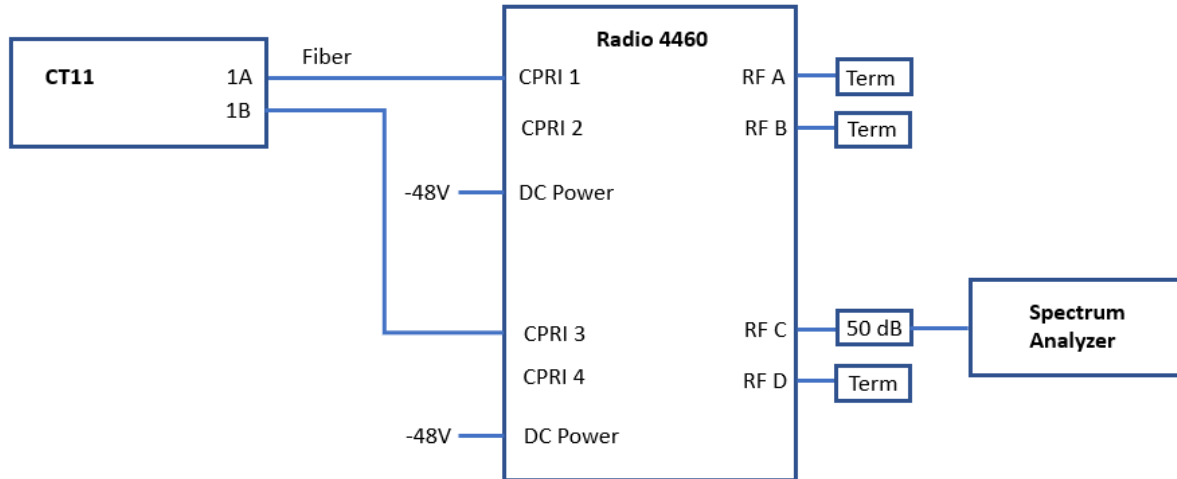

Figure 3.4-1: Setup diagram – Radio Compliance

3.5 Setup photographs

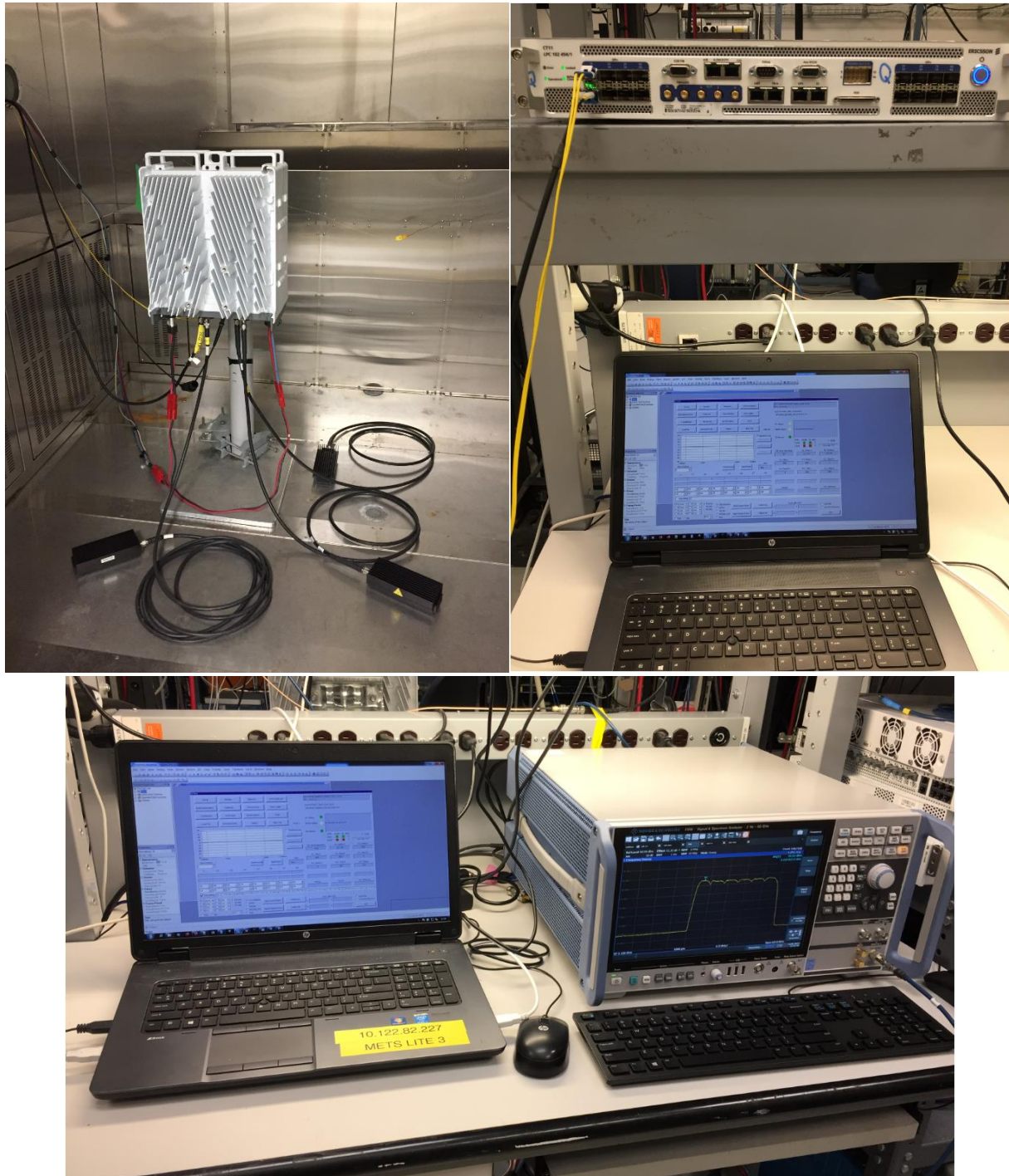

Figure 3.5-1: Set up photo for Radio Compliance Testing

3.6 Setup photographs, continued

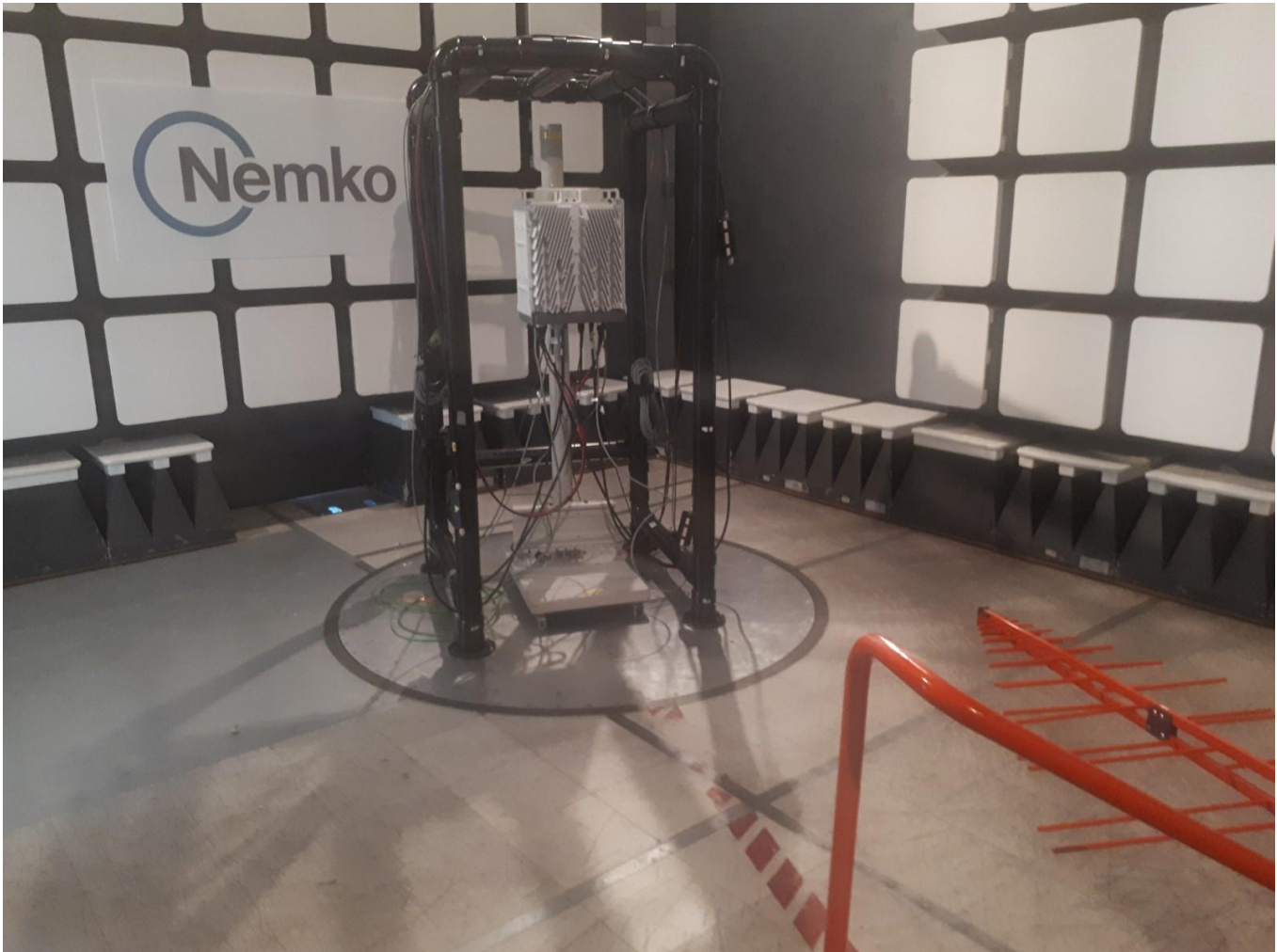

Figure 3.6-1: EUT Set-up photo for Radiated Compliance Testing

Section 4. Engineering considerations

4.1 Modifications incorporated in the EUT

There were no modifications performed to the EUT during this assessment.

4.2 Technical judgment

None

4.3 Deviations from laboratory tests procedures

No deviations were made from laboratory procedures.

Section 5. Test conditions

5.1 Atmospheric conditions

Temperature	15–30 °C
Relative humidity	20–75 %
Air pressure	860–1060 mbar

When it is impracticable to carry out tests under these conditions, a note to this effect stating the ambient temperature and relative humidity during the tests shall be recorded and stated.

5.2 Power supply range

The normal test voltage for equipment to be connected to the mains shall be the nominal mains voltage. For the purpose of the present document, the nominal voltage shall be the declared voltage, or any of the declared voltages $\pm 5\%$, for which the equipment was designed.

Section 6. Measurement uncertainty

6.1 Uncertainty of measurement

Measurement uncertainty budgets for the tests are detailed below. Measurement uncertainty calculations assume a coverage factor of $K = 2$ with 95% certainty.

Test name	Measurement uncertainty, dB
All antenna port measurements	0.55
Conducted spurious emissions	1.13
Radiated spurious emissions	3.78

Section 7. Test equipment

7.1 Test equipment list

Table 7.1-1: Equipment list

Equipment	Manufacturer	Model no.	Asset no.	Cal cycle	Next cal.
3 m EMI test chamber	TDK	SAC-3	FA002047	1 year	March 26, 2022
Flush mount turntable	Sunol	FM2022	FA002082	—	NCR
Controller	Sunol	SC104V	FA002060	—	NCR
Antenna mast	Sunol	TLT2	FA002061	—	NCR
Receiver/spectrum analyzer	Rohde & Schwarz	ESU 26	FA002043	1 year	November 6, 2021
Horn (1–18 GHz)	ETS Lindgren	3117	FA002840	1 year	February 2, 2022
Preamp (1–18 GHz)	ETS Lindgren	124334	FA002873	1 year	October 13, 2021
50 Ω coax cable	C.C.A.	None	FA002556	1 year	March 24, 2022
Horn antenna (18–40 GHz)	EMCO	3116	FA001847	1 year	May 11, 2022
Pre-amplifier (18–26 GHz)	Narda	BBS-1826N612	FA001550	—	VOU
High pass filter (3-18 GHz)	Thilithic Inc.	6HC3000/18000-1.3-KK	FA002231	—	VOU
Spectrum signal analyzer	Rhode&Schwarz	FSW50	FA003267	1 year	December 7, 2021
Power sensor	Rohde & Schwarz	NRP-Z91	FA002488	1 year	May 27, 2022
Testing Equipment*	Ericsson	CT11	T01G495060	—	NCR

Notes: NCR - no calibration required, VOU - verify on use.

* Testing equipment (CT11) is the test equipment that drives the radios traffic.

Section 8. Testing data

8.1 Maximum output power at RF antenna connector (Band 66)

8.1.1 Definitions and limits

FCC §27.50(d) Operation within the bands: 2110–2155 MHz and 2155–2180 MHz.

(1) The power of each fixed or base station transmitting in the 1995–2000 MHz, 2110–2155 MHz, 2155–2180 MHz or 2180–2200 MHz band and located in any county with population density of 100 or fewer persons per square mile, based upon the most recently available population statistics from the Bureau of the Census, is limited to:

(i) An equivalent isotropically radiated power (EIRP) of 3280 watts when transmitting with an emission bandwidth of 1 MHz or less;

(ii) An EIRP of 3280 watts/MHz when transmitting with an emission bandwidth greater than 1 MHz.

(2) The power of each fixed or base station transmitting in the 1995–2000 MHz, the 2110–2155 MHz 2155–2180 MHz band, or 2180–2200 MHz band and situated in any geographic location other than that described in paragraph (d)(1) of this section is limited to:

(i) An equivalent isotropically radiated power (EIRP) of 1640 watts when transmitting with an emission bandwidth of 1 MHz or less;

(ii) An EIRP of 1640 watts/MHz when transmitting with an emission bandwidth greater than 1 MHz.

(3) A licensee operating a base or fixed station in the 2110–2155 MHz band utilizing a power greater than 1640 watts EIRP and greater than 1640 watts/MHz EIRP must coordinate such operations in advance with all Government and non-Government satellite entities in the 2025–2110 MHz band. A licensee operating a base or fixed station in the 2110–2180 MHz band utilizing power greater than 1640 watts EIRP and greater than 1640 watts/MHz EIRP must be coordinated in advance with the following licensees authorized to operate within 120 kilometers (75 miles) of the base or fixed station operating in this band: All Broadband Radio Service (BRS) licensees authorized under this part in the 2155–2160 MHz band and all advanced wireless services (AWS) licensees authorized to operate on adjacent frequency blocks in the 2110–2180 MHz band.

(5) Equipment employed must be authorized in accordance with the provisions of §24.51. Power measurements for transmissions by stations authorized under this section may be made either in accordance with a Commission-approved average power technique or in compliance with paragraph (d)(6) of this section. In measuring transmissions in this band using an average power technique, the peak-to-average ratio (PAR) of the transmission may not exceed 13 dB.

(6) Peak transmit power must be measured over any interval of continuous transmission using instrumentation calibrated in terms of an rms-equivalent voltage. The measurement results shall be properly adjusted for any instrument limitations, such as detector response times, limited resolution bandwidth capability when compared to the emission bandwidth, sensitivity, etc., so as to obtain a true peak measurement for the emission in question over the full bandwidth of the channel.

8.1.1 Definitions and limits, continued

RSS-139, Section 4.1

The transmitter power shall be measured in terms of a root-mean-square (RMS) average value.

RSS-139, Section 6.5

Consult SRSP-513 for e.i.r.p. limits on fixed and base stations operating in the band 2110–2180 MHz.

In addition, the peak to average power ratio (PAPR) of the equipment shall not exceed 13 dB for more than 0.1% of the time, using a signal that corresponds to the highest PAPR during periods of continuous transmission.

RSS-170, Section 5.3.1

Consult SRSP-519 for e.i.r.p. limits on ATC base stations operating in the bands 2000–2020 MHz and 2180–2200 MHz.

SRSP-513, Section 5.1

5.1.1 Fixed and base stations

5.1.1.1 For fixed and base stations operating within the frequency range 2110–2180 MHz with a channel bandwidth equal to or less than 1 MHz, the maximum permissible equivalent isotropically radiated power (e.i.r.p.) is 1640 watts with an antenna height above average terrain (HAAT) up to 300 metres.

5.1.1.2 For fixed and base stations operating within the frequency range 2110–2180 MHz with a channel bandwidth greater than 1 MHz, the maximum permissible e.i.r.p. is 1640 watts/MHz e.i.r.p. (i.e. no more than 1640 watts e.i.r.p. in any 1 MHz band segment) with an antenna height above average terrain (HAAT) up to 300 metres.

5.1.1.3 Fixed and base stations located in geographic areas at a distance greater than 26 km from large or medium population centres, and transmitting within the frequency range 2110–2180 MHz, may increase their e.i.r.p. up to a maximum of 3280 watts/MHz (i.e. no more than 3280 watts e.i.r.p. in any 1 MHz band segment), with an antenna HAAT up to 300 metres.

Within 26 km of any large or medium population centre, fixed and base stations may operate at increased e.i.r.p. if more than 50% of the population within a particular sector's coverage is located outside these large and medium population centres.

Fixed and base stations with increased e.i.r.p. must not be used to provide coverage to large and medium population centres. However, some incidental coverage of these large and medium population centres by stations with increased e.i.r.p. is permitted.

This provision also applies for fixed and base stations with a channel bandwidth equal to or less than 1 MHz (i.e. the e.i.r.p. may be increased up to a maximum of 3280 watts).

5.1.1.4 Fixed and base station antenna heights above average terrain may exceed 300 metres with a reduction in e.i.r.p. The maximum permissible e.i.r.p. for installations with antenna HAAT in excess of 300 metres is given in the following table:

Table 8.1-1: Reduction to Maximum Allowable E.I.R.P. for HAAT > 300 m

HAAT (m)	Maximum EIRP, W/MHz
HAAT ≤ 300	1640 (or 3280 ¹)
300 < HAAT ≤ 500	1070
500 < HAAT ≤ 1000	490
1000 < HAAT ≤ 1500	270
1500 < HAAT ≤ 2000	160

Note: ¹for fixed and base stations with a channel bandwidth equal to or less than 1 MHz

8.1.1 Definitions and limits, continued

SRSP-519, Section 5.1

The equivalent isotropically radiated power (e.i.r.p.) of base stations shall not exceed 1640 W when transmitting with an emission bandwidth of 1 MHz or less, and 1640 W/MHz when transmitting with an emission bandwidth greater than 1 MHz.

Base stations located outside of large or medium population may increase their e.i.r.p. to a maximum of 3280 W when transmitting with an emission bandwidth of 1 MHz or less, and to 3280 W/MHz when transmitting with an emission bandwidth greater than 1 MHz.

A licensee operating a base station utilizing an e.i.r.p greater than 1640 W/MHz must coordinate in advance with all AWS-4 licensees authorized to operate on adjacent frequency blocks within the same band.

Base station antenna heights above average terrain may exceed 300 m with a corresponding reduction in e.i.r.p. in accordance with Table above

8.1.2 Test summary

Test date	January 22, 2021
Test engineer	Andrey Adelberg

8.1.3 Observations, settings, and special notes

Output power was measured with RMS power meter per ANSI C63.26 Paragraph 5.2.4.2 method. PSD was measured using method described in paragraph 5.2.4.4.

- Randomly selected sample plots provided for information and settings only
- Total MIMO PSD was calculated as follows: PSD from one antenna port + $10 \times \text{Log}_{10}(4)$
- RBS (Radio Base Station) EIRP Limits are deployment dependent. To ensure compliance with legal limits detailed in section 8.1.1, RBS set up and carrier configurations are addressed during site commissioning.
- Report results are compiled for the maximum output rated power for worst case emission assessment. EIRP, based on possible beam configuration, indicate the maximum power / worst case beam configuration based on ideal antenna parameters. Customer carrier configuration and power will be limited to comply with legal limits of 1640 W/MHz or 3280 W/MHz during RBS site set up and commissioning. Non-compliant configurations will be restricted to lower carrier power to ensure compliance.
- **To ensure compliance under worst case conditions with maximum output power based on a MIMO configuration, the maximum antenna gain for an RBS (Radio Base Station) system with Radio 4460 44B2/25 44B66 C is 18 dBi with 1 dB path loss. Maximum measured PSD to EIRP margin 17.21 dB.**

Spectrum analyzer settings for PSD:

Detector mode	RMS
Resolution bandwidth	1 MHz
Video bandwidth	>RBW
Measurement mode	Power over emission bandwidth
Trace mode	Averaging
Measurement time	Auto

8.1.4 Test data

Table 8.1-2: EIRP calculation based on the worst-case PSD measurement

Frequency, MHz	RF power density, dBm/MHz	Total MIMO PSD, dBm/MHz	Cable loss, dB	Antenna gain, dBi	EIRP PSD, dBm/MHz	EIRP limit, dBm/MHz	Margin, dB
2117.5	38.92	44.94	-1.00	18.00	61.94	62.15	0.21

Table 8.1-3: RF power density measurement results of a single-carrier operation for LTE on 5 MHz channel

Frequency, MHz	RF power density, dBm/MHz	Total MIMO PSD, dBm/MHz	EIRP limit, dBm/MHz	Margin, dB
2112.5	37.68	43.70	62.15	18.45
2155.0	37.50	43.52	62.15	18.63
2197.5	37.42	43.44	62.15	18.71

Table 8.1-4: RF power density measurement results of a single-carrier operation for LTE with IB on 5 MHz channel

Frequency, MHz	RF power density, dBm/MHz	Total MIMO PSD, dBm/MHz	EIRP limit, dBm/MHz	Margin, dB
2112.5	37.92	43.94	62.15	18.21
2155.0	37.96	43.98	62.15	18.17
2197.5	38.10	44.12	62.15	18.03

Table 8.1-5: RF power density measurement results of a single-carrier operation for NR on 5 MHz channel

Frequency, MHz	RF power density, dBm/MHz	Total MIMO PSD, dBm/MHz	EIRP limit, dBm/MHz	Margin, dB
2112.5	37.86	43.88	62.15	18.27
2155.0	37.80	43.82	62.15	18.33
2197.5	37.80	43.82	62.15	18.33

Table 8.1-6: RF power density measurement results of a single-carrier operation for WCDMA

Frequency, MHz	RF power density, dBm/MHz	Total MIMO PSD, dBm/MHz	EIRP limit, dBm/MHz	Margin, dB
2112.4	38.33	44.35	62.15	17.80
2132.6	38.30	44.32	62.15	17.83
2152.6	38.22	44.24	62.15	17.91

Table 8.1-7: RF power density measurement results of a single-carrier operation for LTE on 10 MHz channel

Frequency, MHz	RF power density, dBm/MHz	Total MIMO PSD, dBm/MHz	EIRP limit, dBm/MHz	Margin, dB
2115.0	37.75	43.77	62.15	18.38
2155.0	37.82	43.84	62.15	18.31
2195.0	37.68	43.70	62.15	18.45

Table 8.1-8: RF power density measurement results of a single-carrier operation for LTE with IoT on 10 MHz channel

Frequency, MHz	RF power density, dBm/MHz	Total MIMO PSD, dBm/MHz	EIRP limit, dBm/MHz	Margin, dB
2115.0	37.09	43.11	62.15	19.04
2155.0	37.53	43.55	62.15	18.60
2195.0	37.13	43.15	62.15	19.00

Test data, continued

Table 8.1-9: RF power density measurement results of a single-carrier operation for NR on 10 MHz channel

Frequency, MHz	RF power density, dBm/MHz	Total MIMO PSD, dBm/MHz	EIRP limit, dBm/MHz	Margin, dB
2115.0	37.18	43.20	62.15	18.95
2155.0	37.12	43.14	62.15	19.01
2195.0	37.08	43.10	62.15	19.05

Table 8.1-10: RF power density measurement results of a single-carrier operation for LTE on 15 MHz channel

Frequency, MHz	RF power density, dBm/MHz	Total MIMO PSD, dBm/MHz	EIRP limit, dBm/MHz	Margin, dB
2117.5	38.44	44.46	62.15	17.69
2155.0	38.64	44.66	62.15	17.49
2192.5	38.54	44.56	62.15	17.59

Table 8.1-11: RF power density measurement results of a single-carrier operation for LTE with IoT on 15 MHz channel

Frequency, MHz	RF power density, dBm/MHz	Total MIMO PSD, dBm/MHz	EIRP limit, dBm/MHz	Margin, dB
2117.5	37.52	43.54	62.15	18.61
2155.0	37.50	43.52	62.15	18.63
2192.5	37.35	43.37	62.15	18.78

Table 8.1-12: RF power density measurement results of a single-carrier operation for NR on 15 MHz channel

Frequency, MHz	RF power density, dBm/MHz	Total MIMO PSD, dBm/MHz	EIRP limit, dBm/MHz	Margin, dB
2117.5	38.92	44.94	62.15	17.21
2155.0	38.73	44.75	62.15	17.40
2192.5	38.68	44.70	62.15	17.45

Table 8.1-13: RF power density measurement results of a single-carrier operation for LTE on 20 MHz channel

Frequency, MHz	RF power density, dBm/MHz	Total MIMO PSD, dBm/MHz	EIRP limit, dBm/MHz	Margin, dB
2120.0	38.15	44.17	62.15	17.98
2155.0	37.99	44.01	62.15	18.14
2190.0	38.05	44.07	62.15	18.08

Table 8.1-14: RF power density measurement results of a single-carrier operation for LTE with IoT on 20 MHz channel

Frequency, MHz	RF power density, dBm/MHz	Total MIMO PSD, dBm/MHz	EIRP limit, dBm/MHz	Margin, dB
2120.0	37.69	43.71	62.15	18.44
2155.0	37.42	43.44	62.15	18.71
2190.0	37.45	43.47	62.15	18.68

Table 8.1-15: RF power density measurement results of a single-carrier operation for NR on 20 MHz channel

Frequency, MHz	RF power density, dBm/MHz	Total MIMO PSD, dBm/MHz	EIRP limit, dBm/MHz	Margin, dB
2120.0	37.34	43.36	62.15	18.79
2155.0	37.30	43.32	62.15	18.83
2190.0	37.45	43.47	62.15	18.68

Test data, continued

Table 8.1-16: RF power density measurement results of a multi-carrier operation for LTE on 5 MHz channel

Notes	RF power density, dBm/MHz	Total MIMO PSD, dBm/MHz	EIRP limit, dBm/MHz	Margin, dB
4 carriers	37.11	43.13	62.15	19.02

Table 8.1-17: RF power density measurement results of a multi-carrier operation for NR on 5 MHz channel

Notes	RF power density, dBm/MHz	Total MIMO PSD, dBm/MHz	EIRP limit, dBm/MHz	Margin, dB
4 carriers	37.68	43.70	62.15	18.45

Table 8.1-18: RF power density measurement results of a multi-carrier operation for LTE on 10 MHz channel

Notes	RF power density, dBm/MHz	Total MIMO PSD, dBm/MHz	EIRP limit, dBm/MHz	Margin, dB
2 carriers	37.06	43.08	62.15	19.07
3 carriers	35.48	41.50	62.15	20.65

Table 8.1-19: RF power density measurement results of a multi-carrier operation for NR on 10 MHz channel

Notes	RF power density, dBm/MHz	Total MIMO PSD, dBm/MHz	EIRP limit, dBm/MHz	Margin, dB
2 carriers	36.94	42.96	62.15	19.19
3 carriers	34.95	40.97	62.15	21.18

Table 8.1-20: RF power density measurement results of a multi-carrier operation for LTE on 15 MHz channel

Notes	RF power density, dBm/MHz	Total MIMO PSD, dBm/MHz	EIRP limit, dBm/MHz	Margin, dB
2 carriers	36.12	42.14	62.15	20.01
3 carriers	34.73	40.75	62.15	21.40

Table 8.1-21: RF power density measurement results of a multi-carrier operation for NR on 15 MHz channel

Notes	RF power density, dBm/MHz	Total MIMO PSD, dBm/MHz	EIRP limit, dBm/MHz	Margin, dB
2 carriers	36.23	42.25	62.15	19.90
3 carriers	34.80	40.82	62.15	21.33

Table 8.1-22: RF power density measurement results of a multi-carrier operation for LTE on 20 MHz channel

Notes	RF power density, dBm/MHz	Total MIMO PSD, dBm/MHz	EIRP limit, dBm/MHz	Margin, dB
2 carriers	34.46	40.48	62.15	21.67
3 carriers	32.93	38.95	62.15	23.20

Table 8.1-23: RF power density measurement results of a multi-carrier operation for NR on 20 MHz channel

Notes	RF power density, dBm/MHz	Total MIMO PSD, dBm/MHz	EIRP limit, dBm/MHz	Margin, dB
2 carriers	34.02	40.04	62.15	22.11
3 carriers	32.06	38.08	62.15	24.07

Test data, continued

Table 8.1-24: RF power density measurement results of a multi-RAT operation

Notes	RF power density, dBm/MHz	Total MIMO PSD, dBm/MHz	EIRP limit, dBm/MHz	Margin, dB
LTE 10 MHz and NR 10 MHz	36.71	42.73	62.15	19.42
LTE 5 MHz and WCDMA and NR 10 MHz	37.47	43.49	62.15	18.66
LTE 15 MHz + NR 5 MHz	37.06	43.08	62.15	19.07
NR 15 MHz + LTE 5 MHz	38.22	44.24	62.15	17.91
LTE 10 MHz and WCDMA and NR 15 MHz	37.33	43.35	62.15	18.80
WCDMA + LTE 15 MHz and NR 5 MHz and NR 10 MHz + LTE 5 MHz and NR 5 MHz	35.65	41.67	62.15	20.48
WCDMA + 4xLTE 5 MHz + NR 5 MHz	35.43	41.45	62.15	20.70
WCDMA + LTE 10 MHz + NR 5 MHz	37.26	43.28	62.15	18.87
WCDMA + NR 10 MHz + LTE 5 MHz	37.18	43.20	62.15	18.95
WCDMA and LTE 15 MHz	37.20	43.22	62.15	18.93
WCDMA + LTE 15 MHz	37.64	43.66	62.15	18.49
WCDMA and NR 15 MHz	37.87	43.89	62.15	18.26
WCDMA + NR 15 MHz	38.25	44.27	62.15	17.88
WCDMA and NR 5 MHz and 4xLTE 5 MHz	35.39	41.41	62.15	20.74

Note: "and": non-contiguous channels; "+": contiguous channels

Test data, continued

Table 8.1-25: RF total channel power measurement results for LTE

Remarks	5 MHz channel (20 W)	10 MHz channel (40 W)	15 MHz channel (60 W)	20 MHz channel (80 W)
Low channel, QPSK	42.89	45.65	47.62	48.80
Low channel, 16-QAM	42.89	45.66	47.63	48.81
Low channel, 64-QAM	42.89	45.65	47.62	48.80
Low channel, 256-QAM	42.86	45.66	47.59	48.81
Mid channel, QPSK	42.85			
Top channel, QPSK	42.80			
Mid channel, 16-QAM		45.82	47.61	48.80
Top channel, 16-QAM		45.61	47.59	48.82
2 carriers, 16-QAM		48.14	48.24	48.25
3 carriers, 16-QAM		48.23	48.33	48.35
4 carriers, QPSK	48.23			

Note: all results in the table are in dBm units

Table 8.1-26: RF total channel power measurement results for LTE with IB or IoT

Remarks	5 MHz channel* (20 W)	10 MHz channel (40 W)	15 MHz channel (60 W)	20 MHz channel (80 W)
Low channel, QPSK	42.84 / 42.84	45.44	47.46	48.60
Mid channel, QPSK	42.80 / 42.80	45.62	47.49	48.59
Top channel, QPSK	42.75 / 42.75	45.42	47.44	48.60

Notes: *Guard-band (IB) at the bottom of the channel or at the top of the channel
All results in the table are in dBm units

Table 8.1-27: RF total channel power measurement results for NR

Remarks	5 MHz channel (20 W)	10 MHz channel (40 W)	15 MHz channel (60 W)	20 MHz channel (80 W)
Low channel, QPSK	42.82	45.66	47.59	48.82
Low channel, 16-QAM	42.83	45.65	47.61	48.80
Low channel, 64-QAM	42.76	45.62	47.58	48.80
Low channel, 256-QAM	42.78	45.66	47.59	48.79
Mid channel, 16-QAM	42.81		47.62	
Top channel, 16-QAM	42.76		47.58	
Mid channel, QPSK		45.81		48.82
Top channel, QPSK		45.61		48.82
2 carriers, QPSK		48.27		48.38
3 carriers, QPSK		48.30		48.45
2 carriers, 16-QAM			48.33	
3 carriers, 16-QAM			48.39	
4 carriers, 16-QAM	48.22			

Note: all results in the table are in dBm units

Test data, continued

Table 8.1-28: RF total channel power measurement results for WCDMA

Remarks	Power (dBm)
Low channel, QPSK	42.81
Low channel, 16-QAM	42.82
Low channel, 64-QAM	42.82
Mid channel, 16-QAM	42.88
Top channel, 16-QAM	42.82

Table 8.1-29: RF total channel power measurement results for multi-RAT operation

Remarks	Power (dBm)
WCDMA and LTE 5 MHz and 4xNR 5 MHz	48.24
LTE 5 MHz and WCDMA and NR 10 MHz	48.25
LTE 10 MHz and WCDMA and NR 5 MHz	48.13
LTE 10 MHz and NR 10 MHz	48.18
WCDMA and LTE 15 MHz	48.11
WCDMA and NR 15 MHz	48.22
WCDMA + LTE 15 MHz and NR 5 MHz and NR 10 MHz + LTE 5 MHz + NR 5 MHz	48.21

Note: "and": non-contiguous channels; "+": contiguous channels

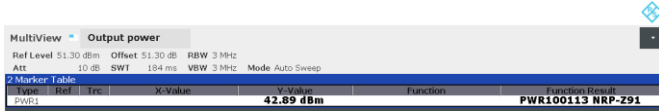

Figure 8.1-1: Output channel power of LTE 5 MHz channel bandwidth, single carrier operation, sample plot

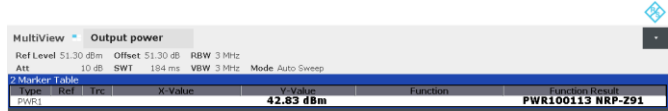

Figure 8.1-2: Output channel power of NR 5 MHz channel bandwidth, single carrier operation, sample plot

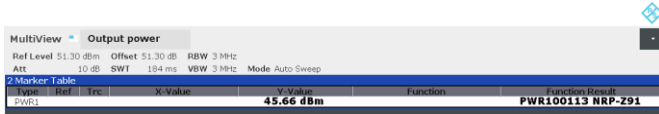

Figure 8.1-3: Output channel power of LTE 10 MHz channel bandwidth, single carrier operation, sample plot



Figure 8.1-4: Output channel power of NR 10 MHz channel bandwidth, single carrier operation, sample plot

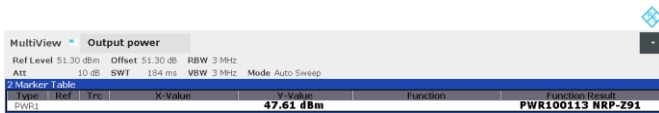

Figure 8.1-5: Output channel power of LTE 15 MHz channel bandwidth, single carrier operation, sample plot



Figure 8.1-6: Output channel power of NR 15 MHz channel bandwidth, single carrier operation, sample plot



Figure 8.1-7: Output channel power of LTE 20 MHz channel bandwidth, single carrier operation, sample plot



Figure 8.1-8: Output channel power of NR 20 MHz channel bandwidth, single carrier operation, sample plot

Test data, continued

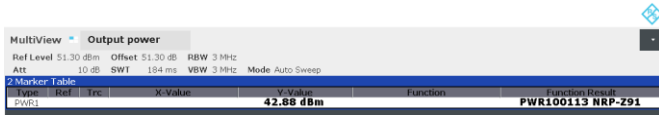

Figure 8.1-9: Output channel power of WCDMA, single carrier operation, sample plot

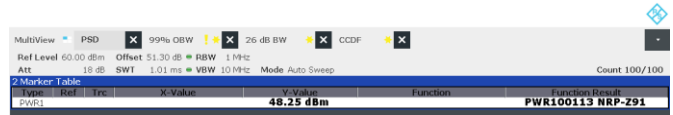

Figure 8.1-10: Output channel power of multi-RAT operation (LTE 5 MHz and WCDMA and NR 10 MHz), single carrier operation, sample plot

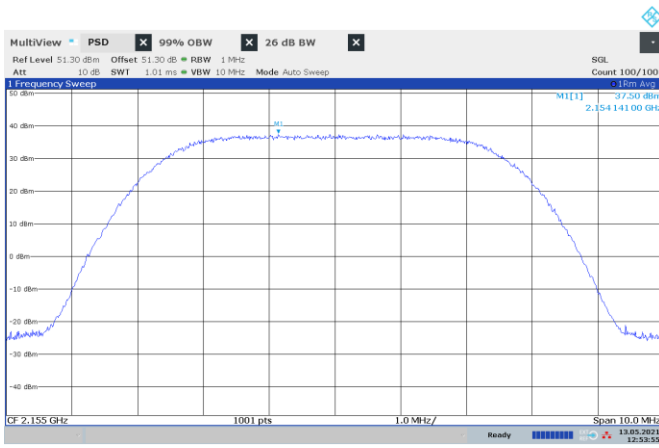

Figure 8.1-11: PSD of LTE 5 MHz channel bandwidth, single carrier operation, sample plot

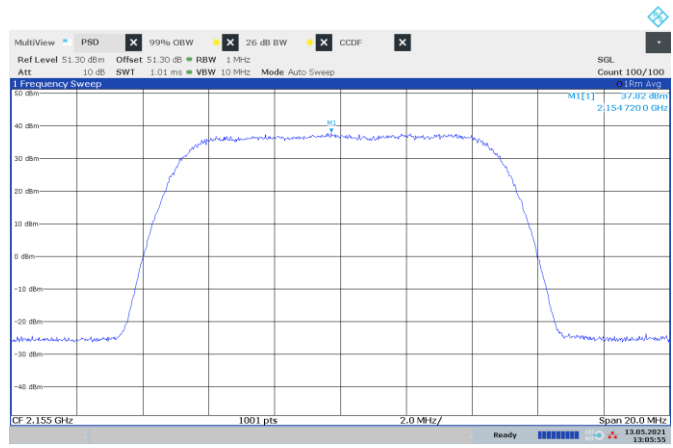

Figure 8.1-12: PSD of LTE 10 MHz channel bandwidth, single carrier operation, sample plot

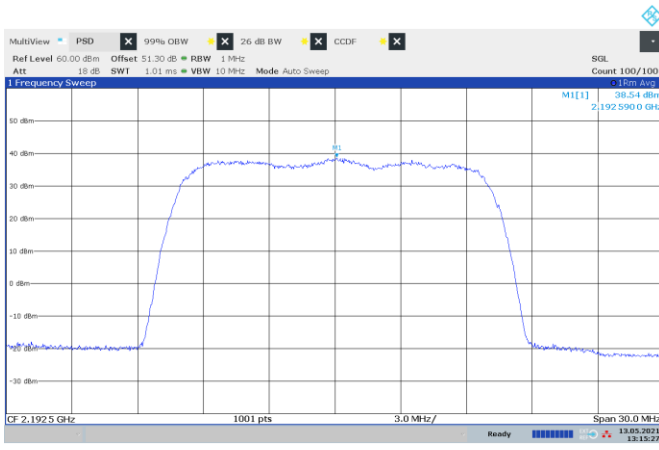

Figure 8.1-13: PSD of LTE 15 MHz channel bandwidth, single carrier operation, sample plot

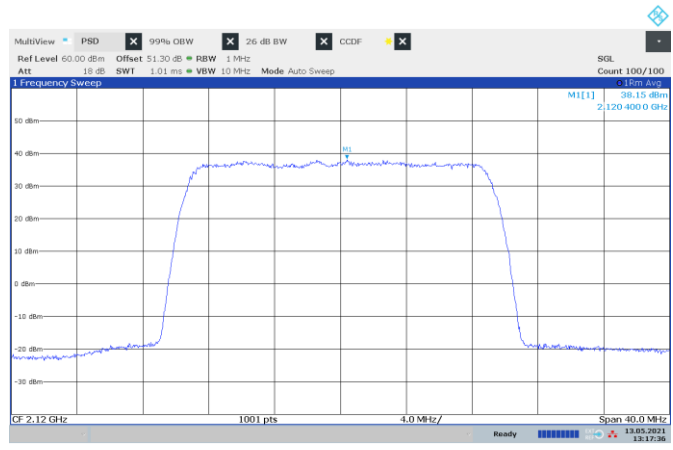

Figure 8.1-14: PSD of LTE 20 MHz channel bandwidth, single carrier operation, sample plot

Test data, continued

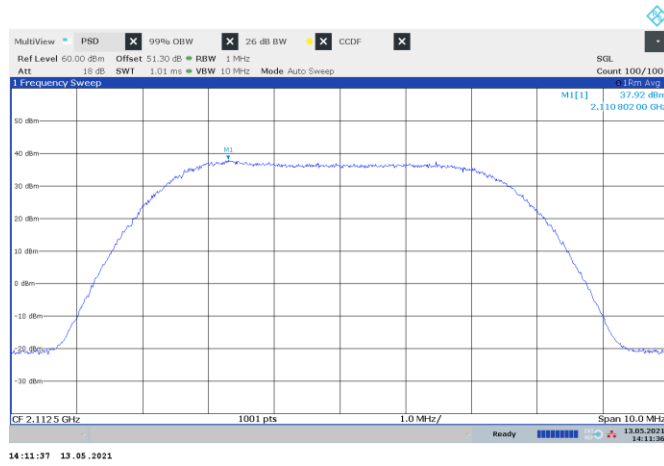

Figure 8.1-15: PSD of LTE 5 MHz channel bandwidth with guard-band, single carrier operation, sample plot

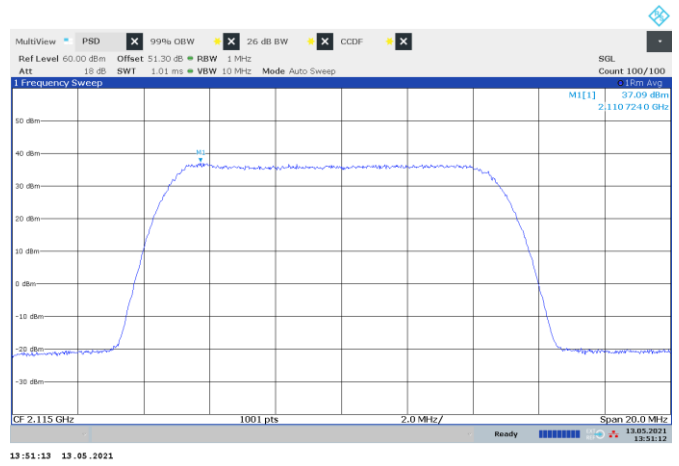

Figure 8.1-16: PSD of LTE 10 MHz channel bandwidth with IoT, single carrier operation, sample plot

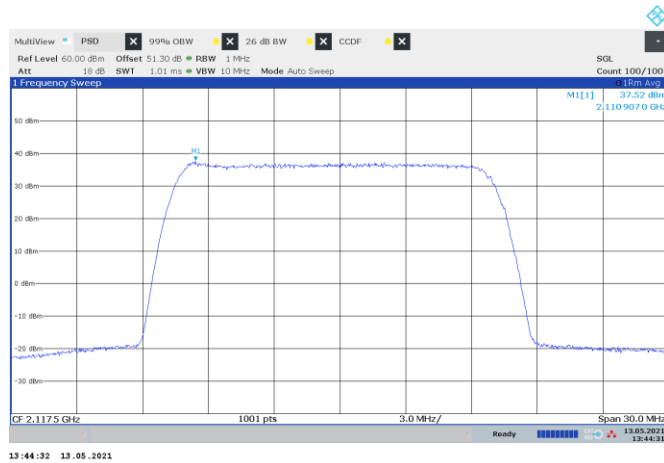

Figure 8.1-17: PSD of LTE 15 MHz channel bandwidth with IoT, single carrier operation, sample plot

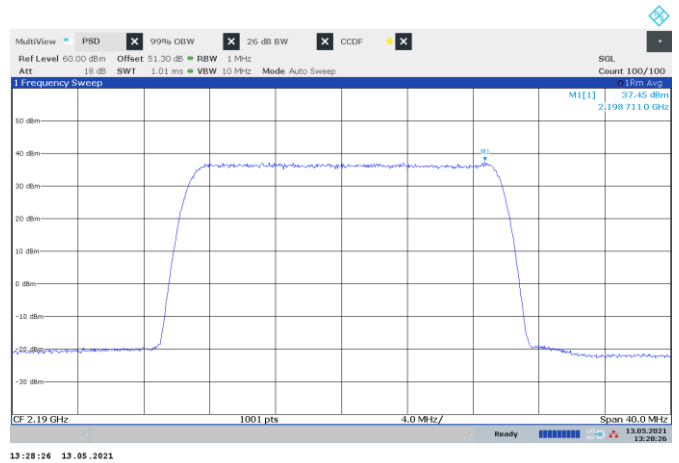

Figure 8.1-18: PSD of LTE 20 MHz channel bandwidth with IoT, single carrier operation, sample plot

Test data, continued

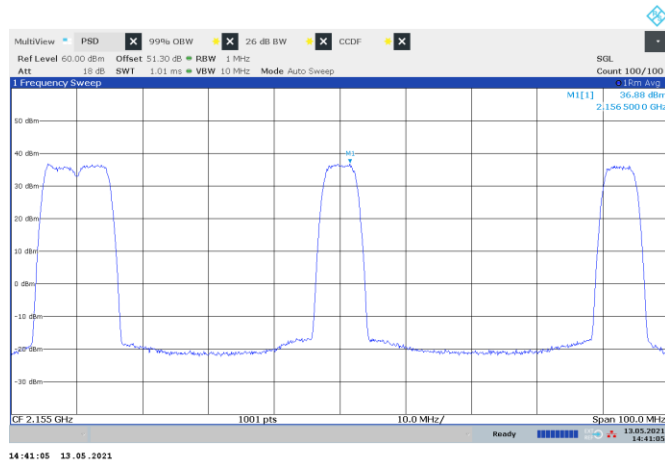

Figure 8.1-19: PSD of LTE 5 MHz channel bandwidth, multi-carrier operation, sample plot

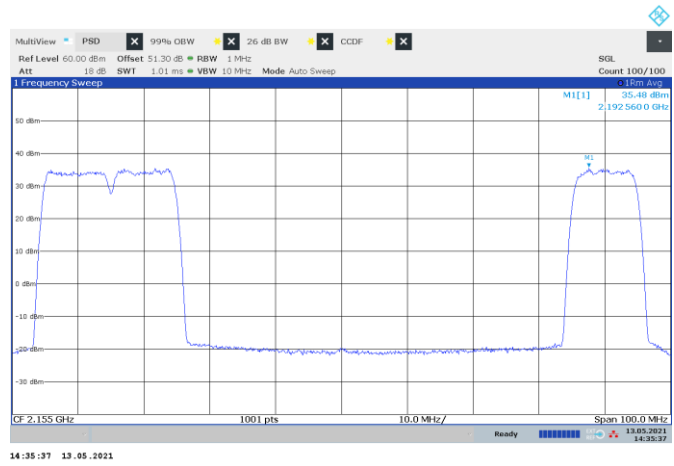

Figure 8.1-20: PSD of LTE 10 MHz channel bandwidth, multi-carrier operation, sample plot

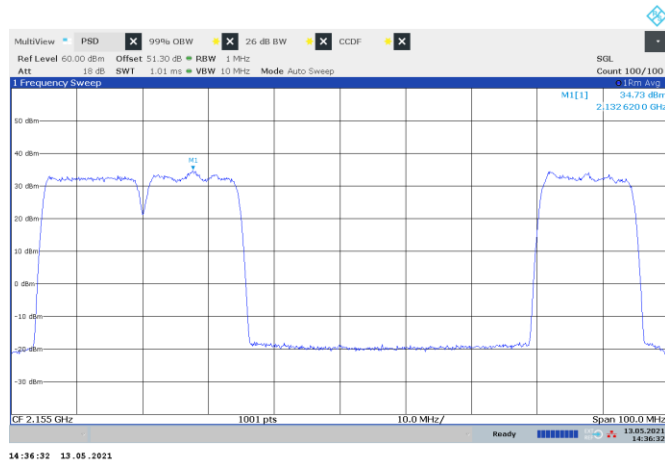

Figure 8.1-21: PSD of LTE 15 MHz channel bandwidth, multi-carrier operation, sample plot

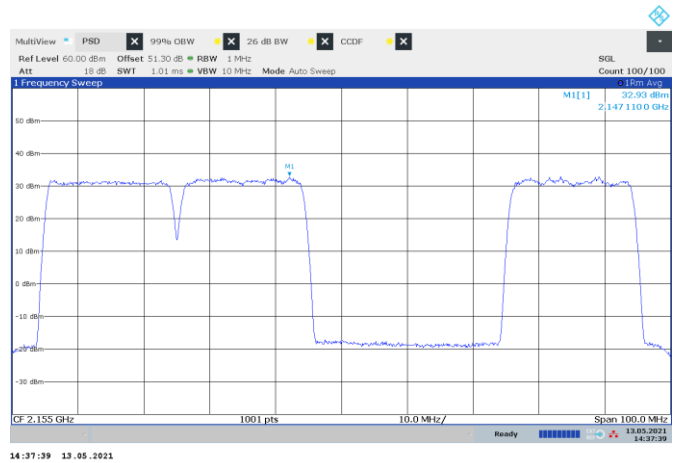

Figure 8.1-22: PSD of LTE 20 MHz channel bandwidth, multi-carrier operation, sample plot

Test data, continued

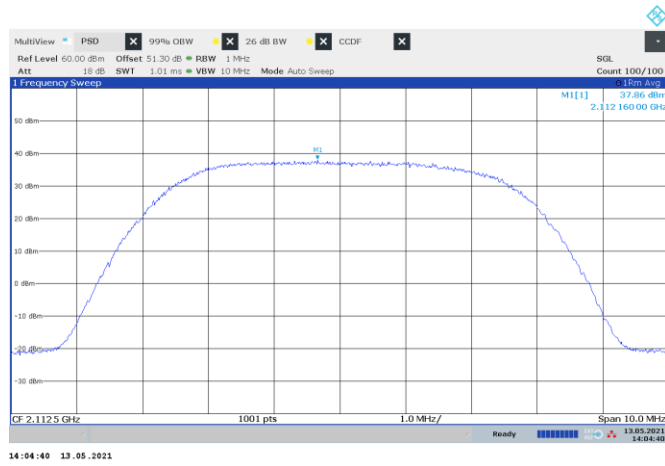

Figure 8.1-23: PSD of NR 5 MHz channel bandwidth, single carrier operation, sample plot

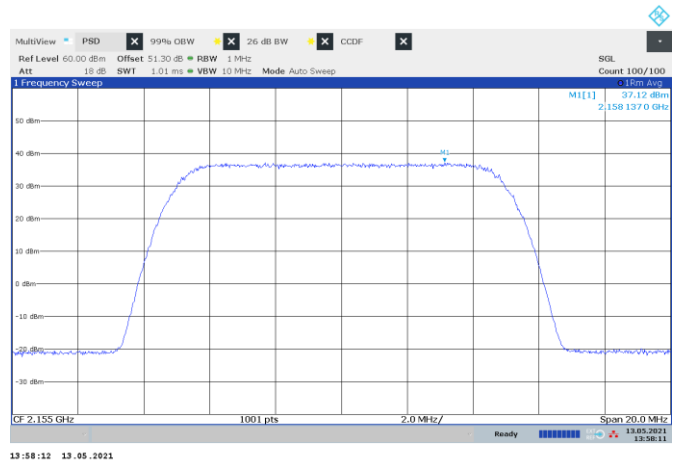

Figure 8.1-24: PSD of NR 10 MHz channel bandwidth, single carrier operation, sample plot



Figure 8.1-25: PSD of NR 15 MHz channel bandwidth, single carrier operation, sample plot

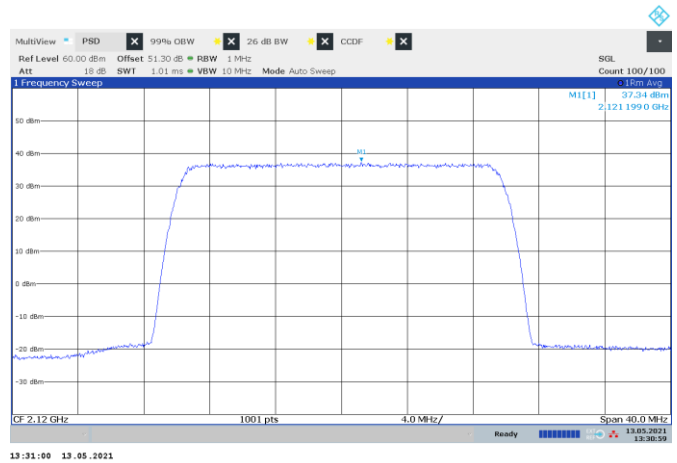

Figure 8.1-26: PSD of NR 20 MHz channel bandwidth, single carrier operation, sample plot

Test data, continued

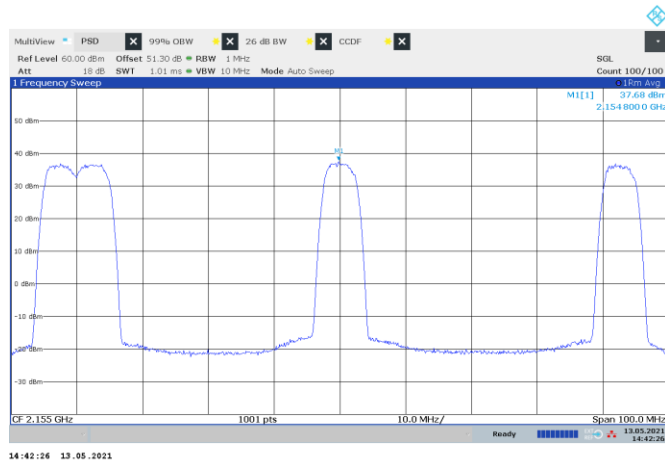

Figure 8.1-27: PSD of NR 5 MHz channel bandwidth, multi-carrier operation, sample plot

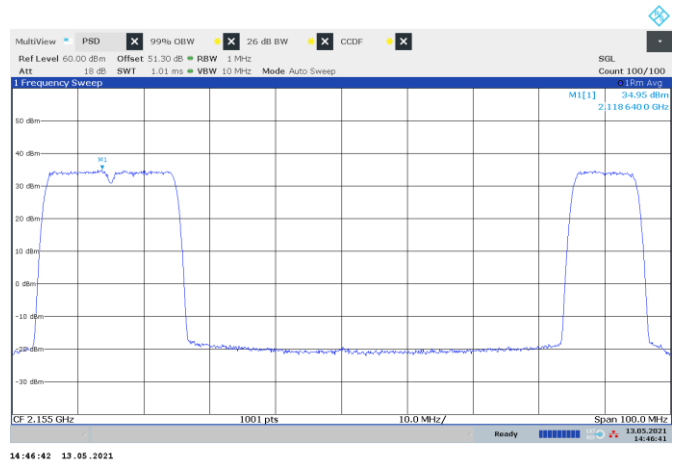

Figure 8.1-28: PSD of NR 10 MHz channel bandwidth, multi-carrier operation, sample plot

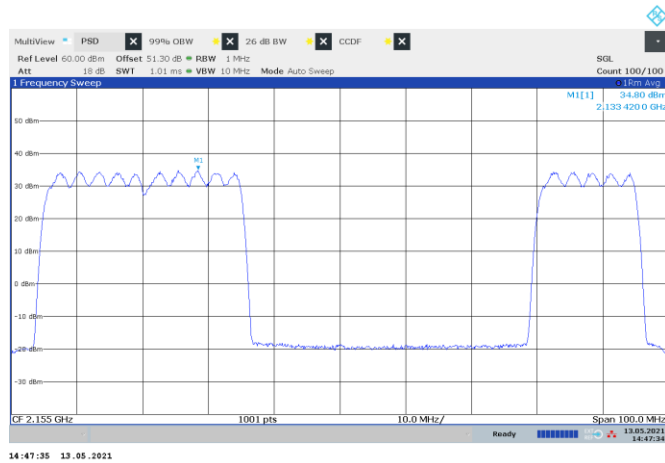

Figure 8.1-29: PSD of NR 15 MHz channel bandwidth, multi-carrier operation, sample plot

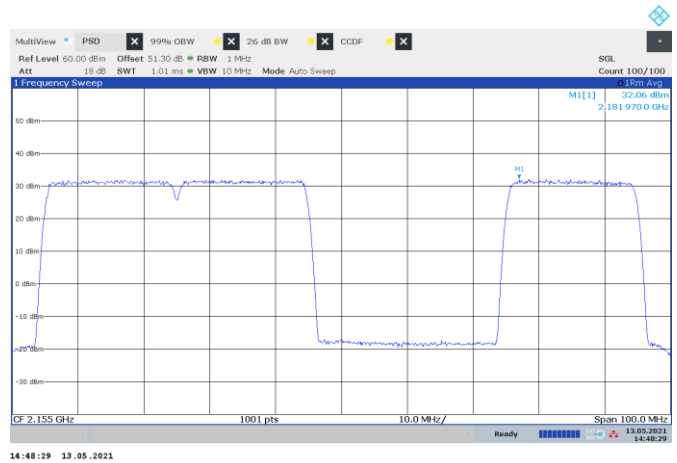

Figure 8.1-30: PSD of NR 20 MHz channel bandwidth, multi-carrier operation, sample plot

Test data, continued

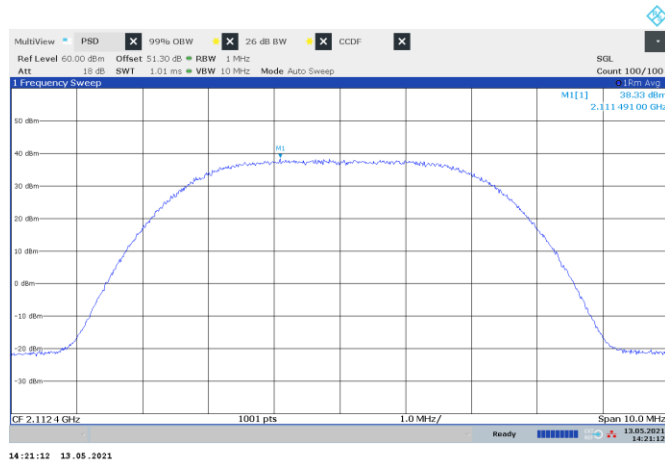

Figure 8.1-31: PSD of WCDMA, sample plot

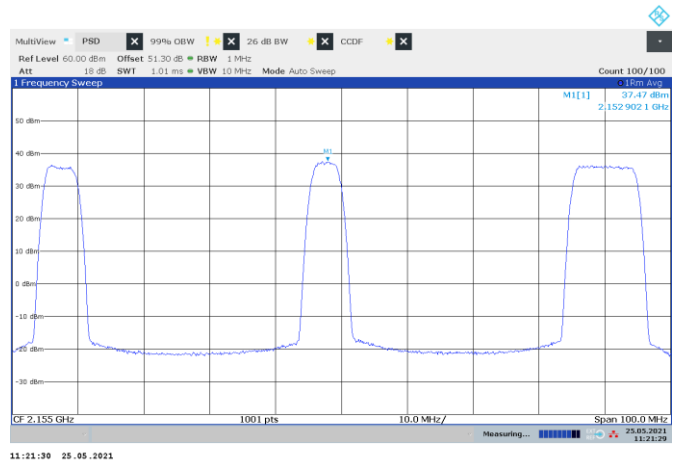

Figure 8.1-32: PSD of multi-RAT operation, LTE 5 MHz and WCDMA and NR 10 MHz

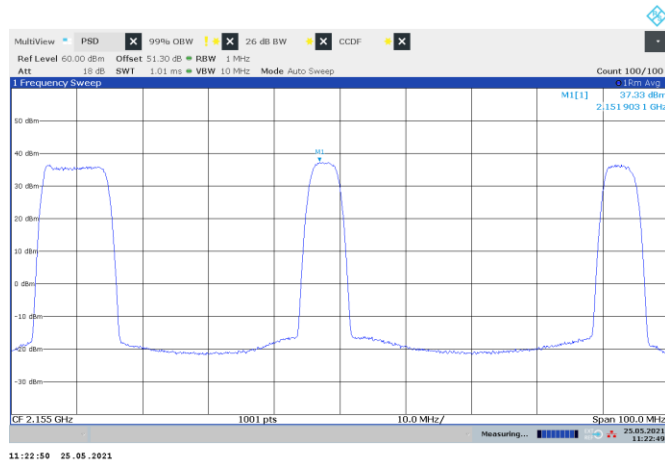

Figure 8.1-33: PSD of multi-RAT operation, LTE 10 MHz and WCDMA and NR 5 MHz

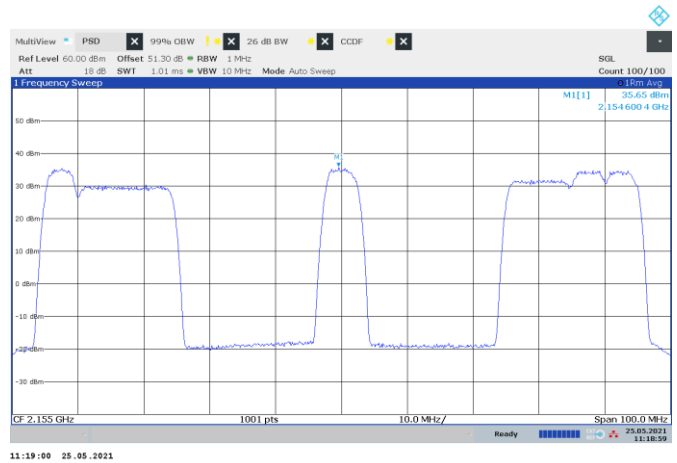

Figure 8.1-34: PSD of multi-RAT operation, WCDMA + LTE 15 MHz and NR 5 MHz and NR 10 MHz + LTE 5 MHz + NR 5 MHz

Test data, continued

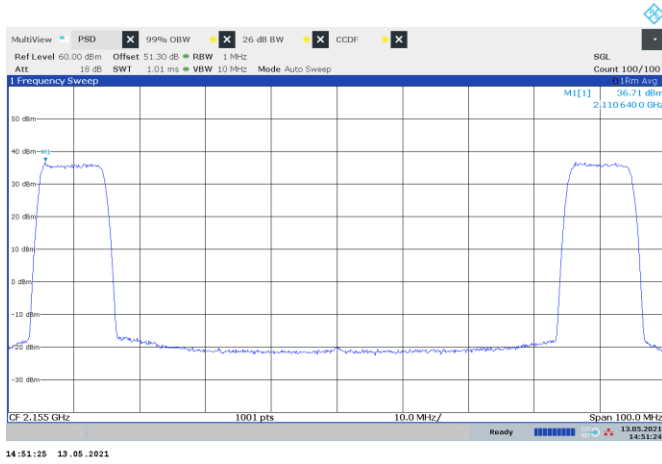

Figure 8.1-35: PSD of multi-RAT operation, LTE 10 MHz and NR 10 MHz

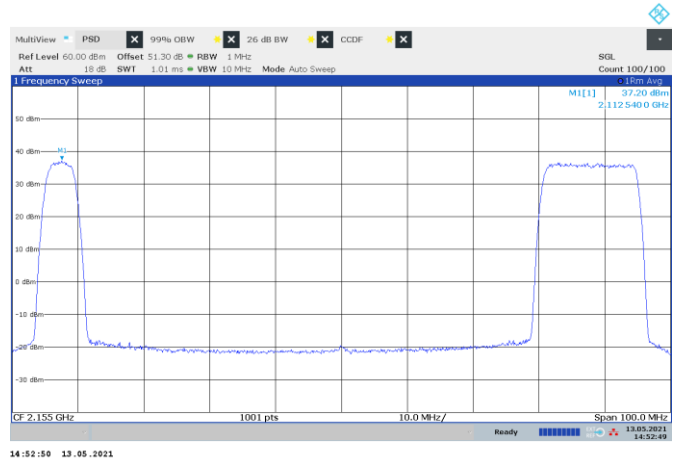

Figure 8.1-36: PSD of multi-RAT operation, WCDMA and LTE 15 MHz

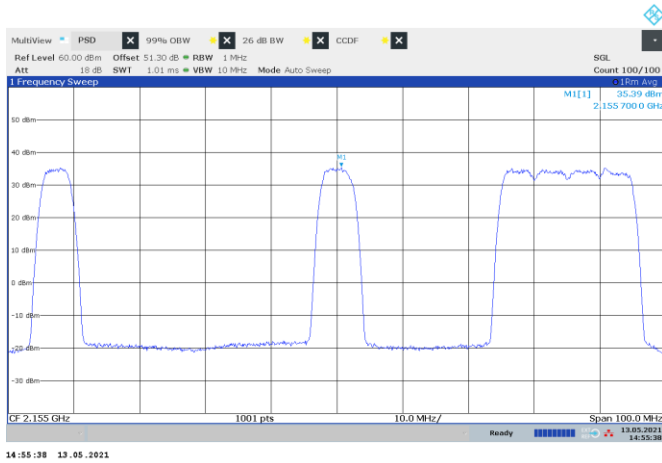

Figure 8.1-37: PSD of multi-RAT operation, WCDMA and LTE 5 MHz and 4xNR 5 MHz

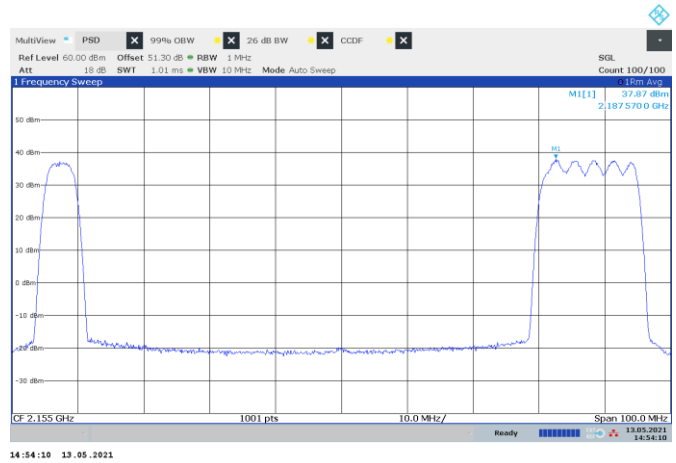

Figure 8.1-38: PSD of multi-RAT operation, WCDMA and NR 15 MHz

Test data, continued

Table 8.1-30: Complementary Cumulative Distribution Function (CCDF) of the PAPR reduction measurement results for single carrier operation for LTE 5 MHz

Remarks	Frequency, MHz	0.1% CCDF, dB	PAPR reduction limit, dB	Margin, dB
5 MHz, Low channel	2112.5	8.44	13.00	4.56
5 MHz, Mid channel	2155.0	8.36	13.00	4.64
5 MHz, Top channel	2197.5	8.36	13.00	4.64
5 MHz with guard-band (IB), Low	2112.5	8.34	13.00	4.66
5 MHz with guard-band (IB), Mid	2155.0	8.32	13.00	4.68
5 MHz with guard-band (IB), Top	2197.5	8.36	13.00	4.64

Table 8.1-31: Complementary Cumulative Distribution Function (CCDF) of the PAPR reduction measurement results for single carrier operation for LTE 10 MHz

Remarks	Frequency, MHz	0.1% CCDF, dB	PAPR reduction limit, dB	Margin, dB
10 MHz, Low channel	2115.0	8.32	13.00	4.68
10 MHz, Mid channel	2155.0	8.34	13.00	4.66
10 MHz, Top channel	2195.0	8.36	13.00	4.64
10 MHz with IoT, Low channel	2115.0	8.34	13.00	4.66
10 MHz with IoT, Mid channel	2155.0	8.36	13.00	4.64
10 MHz with IoT, Top channel	2195.0	8.44	13.00	4.56

Table 8.1-32: Complementary Cumulative Distribution Function (CCDF) of the PAPR reduction measurement results for single carrier operation for LTE 15 MHz

Remarks	Frequency, MHz	0.1% CCDF, dB	PAPR reduction limit, dB	Margin, dB
15 MHz, Low channel	2112.5	8.22	13.00	4.78
15 MHz, Mid channel	2155.0	8.18	13.00	4.82
15 MHz, Top channel	2197.5	8.22	13.00	4.78
15 MHz with IoT, Low channel	2112.5	8.24	13.00	4.76
15 MHz with IoT, Mid channel	2155.0	8.18	13.00	4.82
15 MHz with IoT, Top channel	2197.5	8.16	13.00	4.84

Table 8.1-33: Complementary Cumulative Distribution Function (CCDF) of the PAPR reduction measurement results for single carrier operation for LTE 20 MHz

Remarks	Frequency, MHz	0.1% CCDF, dB	PAPR reduction limit, dB	Margin, dB
20 MHz, Low channel	2120.0	8.00	13.00	5.00
20 MHz, Mid channel	2155.0	8.00	13.00	5.00
20 MHz, Top channel	2190.0	8.06	13.00	4.94
20 MHz with IoT, Low channel	2120.0	8.12	13.00	4.88
20 MHz with IoT, Mid channel	2155.0	8.08	13.00	4.92
20 MHz with IoT, Top channel	2190.0	8.16	13.00	4.84

Table 8.1-34: Complementary Cumulative Distribution Function (CCDF) of the PAPR reduction measurement results for single carrier operation for WCDMA

Remarks	Frequency, MHz	0.1% CCDF, dB	PAPR reduction limit, dB	Margin, dB
Low channel	2112.4	7.34	13.00	5.66
Mid channel	2132.6	7.34	13.00	5.66
Top channel	2152.6	7.34	13.00	5.66

Test data, continued

Table 8.1-35: Complementary Cumulative Distribution Function (CCDF) of the PAPR reduction measurement results for single carrier operation for NR 5 MHz

Remarks	Frequency, MHz	0.1% CCDF, dB	PAPR reduction limit, dB	Margin, dB
5 MHz, Low channel	2112.5	8.60	13.00	4.40
5 MHz, Mid channel	2155.0	8.28	13.00	4.72
5 MHz, Top channel	2197.5	8.50	13.00	4.50

Table 8.1-36: Complementary Cumulative Distribution Function (CCDF) of the PAPR reduction measurement results for single carrier operation for NR 10 MHz

Remarks	Frequency, MHz	0.1% CCDF, dB	PAPR reduction limit, dB	Margin, dB
10 MHz, Low channel	2115.0	8.28	13.00	4.72
10 MHz, Mid channel	2155.0	8.62	13.00	4.38
10 MHz, Top channel	2195.0	8.42	13.00	4.58

Table 8.1-37: Complementary Cumulative Distribution Function (CCDF) of the PAPR reduction measurement results for single carrier operation for NR 15 MHz

Remarks	Frequency, MHz	0.1% CCDF, dB	PAPR reduction limit, dB	Margin, dB
15 MHz, Low channel	2112.5	8.44	13.00	4.56
15 MHz, Mid channel	2155.0	8.42	13.00	4.58
15 MHz, Top channel	2197.5	8.44	13.00	4.56

Table 8.1-38: Complementary Cumulative Distribution Function (CCDF) of the PAPR reduction measurement results for single carrier operation for NR 20 MHz

Remarks	Frequency, MHz	0.1% CCDF, dB	PAPR reduction limit, dB	Margin, dB
20 MHz, Low channel	2120.0	8.40	13.00	4.60
20 MHz, Mid channel	2155.0	8.08	13.00	4.92
20 MHz, Top channel	2190.0	8.22	13.00	4.78

Test data, continued

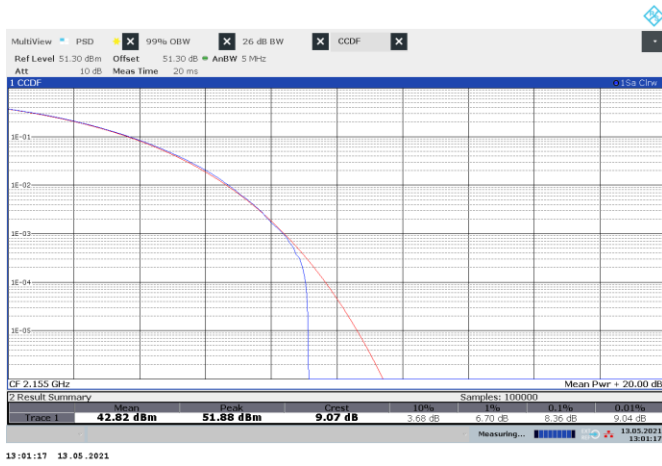

Figure 8.1-39: CCDF sample plot, LTE



Figure 8.1-40: CCDF sample plot, NR

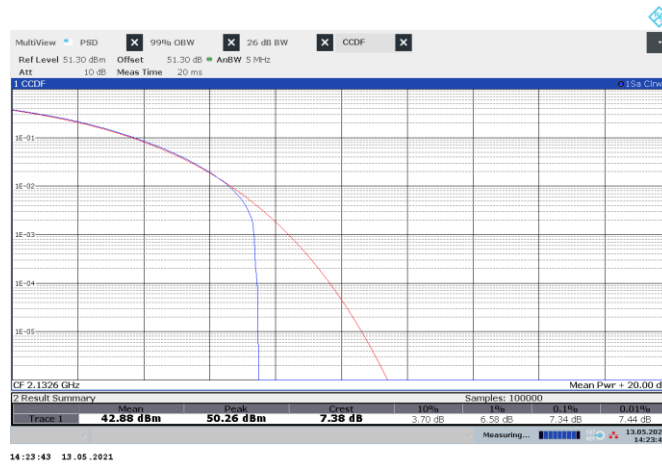

Figure 8.1-41: CCDF sample plot, WCDMA

8.2 Transmitter output power (EIRP) and antenna height (Band 2/25)

8.2.1 Definitions and limits

FCC §24.232(a)(2):

Base stations with an emission bandwidth greater than 1 MHz are limited to 1640 watts/MHz equivalent isotropically radiated power (EIRP) with an antenna height up to 300 meters HAAT, except as described in paragraph (b) below.

(2) Base station antenna heights may exceed 300 meters HAAT with a corresponding reduction in power; see table below.

(b)(1) Base stations that are located in counties with population densities of 100 persons or fewer per square mile, based upon the most recently available population statistics from the Bureau of the Census, with an emission bandwidth of 1 MHz or less are limited to 3280 watts equivalent isotropically radiated power (EIRP) with an antenna height up to 300 meters HAAT.

(d) Power measurements for transmissions by stations authorized under this section may be made either in accordance with a Commission-approved average power technique or in compliance with paragraph (e) of this section. In both instances, equipment employed must be authorized in accordance with the provisions of §24.51. In measuring transmissions in this band using an average power technique, the peak-to-average ratio (PAR) of the transmission may not exceed 13 dB.

RSS-133, Section 6.4

The equivalent isotropically radiated power (e.i.r.p.) for transmitters shall not exceed the limits given in SRSP-510.

In addition, the transmitter's peak-to-average power ratio (PAPR) shall not exceed 13 dB for more than 0.1% of the time using a signal corresponding to the highest PAPR during periods of continuous transmission.

SRSP-510, Section 5.1

5.1.1 Base stations

For base stations with a channel bandwidth greater than 1 MHz, the maximum e.i.r.p. is limited to 3280 watts/MHz e.i.r.p. (i.e., no more than 3280 watts e.i.r.p. in any 1 MHz band segment) with an antenna height above average terrain (HAAT) up to 300 metres. Fixed or base stations operating in urban areas are limited to a maximum allowable e.i.r.p. of 1640 watts/MHz e.i.r.p. Base station antenna heights above average terrain may exceed 300 metres with a corresponding reduction in e.i.r.p. according to the following table.

Table 8.2-1: Reduction to Maximum Allowable E.I.R.P. for HAAT > 300 m

HAAT (m)	Maximum EIRP, W/MHz
HAAT ≤ 300	1640
300 < HAAT ≤ 500	1070
500 < HAAT ≤ 1000	490
1000 < HAAT ≤ 1500	270
1500 < HAAT ≤ 2000	160

8.2.2 Test summary

Test date	May 12, 2021
Test engineer	Andrey Adelberg

8.2.3 Observations, settings, and special notes

Output power was measured with RMS power meter per ANSI C63.26 Paragraph 5.2.4.2 method. PSD was measured using method described in paragraph 5.2.4.4.

- Randomly selected sample plots provided for information and settings only
- Total MIMO PSD was calculated as follows: PSD from one antenna port + $10 \times \text{Log}_{10}(4)$
- There is no MIMO operation with GSM and CDMA
- RBS (Radio Base Station) EIRP Limits are deployment dependent. To ensure compliance with legal limits detailed in section 8.1.2, RBS set up and carrier configurations are addressed during site commissioning.
- Report results are compiled for the maximum output rated power for worst case emission assessment. EIRP, based on possible beam configuration, indicate the maximum power / worst case beam configuration based on ideal antenna parameters. Customer carrier configuration and power will be limited to comply with legal limits of 1640 W/MHz or 3280 W/MHz during RBS site set up and commissioning. Non-compliant configurations will be restricted to lower carrier power to ensure compliance.
- **To ensure compliance under worst case conditions with maximum output power based on a MIMO configuration, the maximum antenna gain for an RBS (Radio Base Station) system with Radio 4460 44B2/25 44B66 C is 18 dBi with 1 dB path loss. Maximum measured PSD to EIRP margin 17.08 dB.**

Spectrum analyzer settings for PSD:

Detector mode	RMS
Resolution bandwidth	1 MHz
Video bandwidth	>RBW
Measurement mode	Power over emission bandwidth
Trace mode	Averaging

8.2.1 Test data

Table 8.2-2: EIRP calculation based on the worst-case PSD measurement

Frequency, MHz	RF power density, dBm/MHz	Total MIMO PSD, dBm/MHz	Cable loss, dB	Antenna gain, dBi	EIRP PSD, dBm/MHz	EIRP limit, dBm/MHz	Margin, dB
1937.5	39.05	45.07	-1.00	18.00	62.07	62.15	0.08

Table 8.2-3: RF power density measurement results of a single-carrier operation for LTE on 5 MHz channel

Frequency, MHz	RF power density, dBm/MHz	Total MIMO PSD, dBm/MHz	EIRP limit, dBm/MHz	Margin, dB
1932.5	37.51	43.53	62.15	18.62
1962.5	37.61	43.63	62.15	18.52
1992.5	37.66	43.68	62.15	18.47

Table 8.2-4: RF power density measurement results of a single-carrier operation for LTE with IB on 5 MHz channel

Frequency, MHz	RF power density, dBm/MHz	Total MIMO PSD, dBm/MHz	EIRP limit, dBm/MHz	Margin, dB
1932.5	38.06	44.08	62.15	18.07
1962.5	38.04	44.06	62.15	18.09
1992.5	38.10	44.12	62.15	18.03

Table 8.2-5: RF power density measurement results of a single-carrier operation for NR on 5 MHz channel

Frequency, MHz	RF power density, dBm/MHz	Total MIMO PSD, dBm/MHz	EIRP limit, dBm/MHz	Margin, dB
1932.5	37.83	43.85	62.15	18.30
1962.5	37.91	43.93	62.15	18.22
1992.5	37.98	44.00	62.15	18.15

Table 8.2-6: RF power density measurement results of a single-carrier operation for WCDMA

Frequency, MHz	RF power density, dBm/MHz	Total MIMO PSD, dBm/MHz	EIRP limit, dBm/MHz	Margin, dB
1932.4	38.43	44.45	62.15	17.70
1960.0	38.30	44.32	62.15	17.83
1987.6	38.28	44.30	62.15	17.85

Table 8.2-7: RF power density measurement results of a single-carrier operation for CDMA

Frequency, MHz	RF power density, dBm/MHz	EIRP limit, dBm/MHz	Margin, dB
1931.25	41.72	62.15	20.43
1960.00	42.26	62.15	19.89
1988.75	41.67	62.15	20.48

Table 8.2-8: RF power density measurement results of a single-carrier operation for GSM

Frequency, MHz	RF power density, dBm/MHz	EIRP limit, dBm/MHz	Margin, dB
1930.2	42.76	62.15	19.39
1960.0	42.93	62.15	19.22
1989.8	42.84	62.15	19.31

Test data, continued

Table 8.2-9: RF power density measurement results of a single-carrier operation for LTE on 10 MHz channel

Frequency, MHz	RF power density, dBm/MHz	Total MIMO PSD, dBm/MHz	EIRP limit, dBm/MHz	Margin, dB
1935.0	38.48	44.50	62.15	17.65
1962.5	38.67	44.69	62.15	17.46
1990.0	38.01	44.03	62.15	18.12

Table 8.2-10: RF power density measurement results of a single-carrier operation for LTE with IoT on 10 MHz channel

Frequency, MHz	RF power density, dBm/MHz	Total MIMO PSD, dBm/MHz	EIRP limit, dBm/MHz	Margin, dB
1935.0	37.40	43.42	62.15	18.73
1962.5	38.61	44.63	62.15	17.52
1990.0	37.77	43.79	62.15	18.36

Table 8.2-11: RF power density measurement results of a single-carrier operation for NR on 10 MHz channel

Frequency, MHz	RF power density, dBm/MHz	Total MIMO PSD, dBm/MHz	EIRP limit, dBm/MHz	Margin, dB
1935.0	38.33	44.35	62.15	17.80
1962.5	38.37	44.39	62.15	17.76
1990.0	38.36	44.38	62.15	17.77

Table 8.2-12: RF power density measurement results of a single-carrier operation for LTE on 15 MHz channel

Frequency, MHz	RF power density, dBm/MHz	Total MIMO PSD, dBm/MHz	EIRP limit, dBm/MHz	Margin, dB
1937.5	38.96	44.98	62.15	17.17
1962.5	38.91	44.93	62.15	17.22
1987.5	38.86	44.88	62.15	17.27

Table 8.2-13: RF power density measurement results of a single-carrier operation for LTE with IoT on 15 MHz channel

Frequency, MHz	RF power density, dBm/MHz	Total MIMO PSD, dBm/MHz	EIRP limit, dBm/MHz	Margin, dB
1937.5	37.59	43.61	62.15	18.54
1962.5	37.92	43.94	62.15	18.21
1987.5	37.51	43.53	62.15	18.62

Table 8.2-14: RF power density measurement results of a single-carrier operation for NR on 15 MHz channel

Frequency, MHz	RF power density, dBm/MHz	Total MIMO PSD, dBm/MHz	EIRP limit, dBm/MHz	Margin, dB
1937.5	39.05	45.07	62.15	17.08
1962.5	38.97	44.99	62.15	17.16
1987.5	38.92	44.94	62.15	17.21

Test data, continued

Table 8.2-15: RF power density measurement results of a single-carrier operation for LTE on 20 MHz channel

Frequency, MHz	RF power density, dBm/MHz	Total MIMO PSD, dBm/MHz	EIRP limit, dBm/MHz	Margin, dB
1940.0	38.00	44.02	62.15	18.13
1962.5	37.66	43.68	62.15	18.47
1985.0	37.60	43.62	62.15	18.53

Table 8.2-16: RF power density measurement results of a single-carrier operation for LTE with IoT on 20 MHz channel

Frequency, MHz	RF power density, dBm/MHz	Total MIMO PSD, dBm/MHz	EIRP limit, dBm/MHz	Margin, dB
1940.0	37.43	43.45	62.15	18.70
1962.5	37.82	43.84	62.15	18.31
1985.0	37.60	43.62	62.15	18.53

Table 8.2-17: RF power density measurement results of a single-carrier operation for NR on 20 MHz channel

Frequency, MHz	RF power density, dBm/MHz	Total MIMO PSD, dBm/MHz	EIRP limit, dBm/MHz	Margin, dB
1940.0	37.62	43.64	62.15	18.51
1962.5	37.38	43.40	62.15	18.75
1985.0	37.50	43.52	62.15	18.63

Table 8.2-18: RF power density measurement results of a multi-carrier operation for LTE on 5 MHz channel

Notes	RF power density, dBm/MHz	Total MIMO PSD, dBm/MHz	EIRP limit, dBm/MHz	Margin, dB
4 carriers	36.88	42.90	62.15	19.25

Table 8.2-19: RF power density measurement results of a multi-carrier operation for NR on 5 MHz channel

Notes	RF power density, dBm/MHz	Total MIMO PSD, dBm/MHz	EIRP limit, dBm/MHz	Margin, dB
4 carriers	37.17	43.19	62.15	18.96

Table 8.2-20: RF power density measurement results of a multi-carrier operation for LTE on 10 MHz channel

Notes	RF power density, dBm/MHz	Total MIMO PSD, dBm/MHz	EIRP limit, dBm/MHz	Margin, dB
2 carriers	37.47	43.49	62.15	18.66
3 carriers	35.75	41.77	62.15	20.38

Table 8.2-21: RF power density measurement results of a multi-carrier operation for NR on 10 MHz channel

Notes	RF power density, dBm/MHz	Total MIMO PSD, dBm/MHz	EIRP limit, dBm/MHz	Margin, dB
2 carriers	37.67	43.69	62.15	18.46
3 carriers	35.84	41.86	62.15	20.29

Test data, continued

Table 8.2-22: RF power density measurement results of a multi-carrier operation for LTE on 15 MHz channel

Notes	RF power density, dBm/MHz	Total MIMO PSD, dBm/MHz	EIRP limit, dBm/MHz	Margin, dB
2 carriers	36.83	42.85	62.15	19.30
3 carriers	34.81	40.83	62.15	21.32

Table 8.2-23: RF power density measurement results of a multi-carrier operation for NR on 15 MHz channel

Notes	RF power density, dBm/MHz	Total MIMO PSD, dBm/MHz	EIRP limit, dBm/MHz	Margin, dB
2 carriers	36.47	42.49	62.15	19.66
3 carriers	34.93	40.95	62.15	21.20

Table 8.2-24: RF power density measurement results of a multi-carrier operation for LTE on 20 MHz channel

Notes	RF power density, dBm/MHz	Total MIMO PSD, dBm/MHz	EIRP limit, dBm/MHz	Margin, dB
2 carriers	34.67	40.69	62.15	21.46
3 carriers	32.92	38.94	62.15	23.21

Table 8.2-25: RF power density measurement results of a multi-carrier operation for NR on 20 MHz channel

Notes	RF power density, dBm/MHz	Total MIMO PSD, dBm/MHz	EIRP limit, dBm/MHz	Margin, dB
2 carriers	34.00	40.02	62.15	22.13
3 carriers	32.24	38.26	62.15	23.89

Table 8.2-26: RF power density measurement results of a multi-RAT operation (MIMO)

Notes	RF power density, dBm/MHz	PSD MIMO, dBm/MHz	EIRP limit, dBm/MHz	Margin, dB
LTE 15 MHz + NR 5 MHz	37.20	43.22	62.15	18.93
NR 15 MHz + LTE 5 MHz	38.18	44.20	62.15	17.95
LTE 5 MHz and WCDMA + NR 10 MHz	37.36	43.38	62.15	18.77
LTE 10 MHz and NR 10 MHz	37.56	43.58	62.15	18.57
LTE 10 MHz and WCDMA + NR 5 MHz	37.48	43.50	62.15	18.65
WCDMA + 4xNR 5 MHz + LTE 5 MHz	35.61	41.63	62.15	20.52
WCDMA and LTE 5 MHz and 4xNR 5 MHz	35.53	41.55	62.15	20.60
WCDMA + LTE 10 MHz + NR 5 MHz	37.26	43.28	62.15	18.87
WCDMA + NR 10 MHz + LTE 5 MHz	37.48	43.50	62.15	18.65
WCDMA and LTE 15 MHz	37.21	43.23	62.15	18.92
WCDMA + LTE 15 MHz	37.46	43.48	62.15	18.67
WCDMA and NR 15 MHz	38.23	44.25	62.15	17.90
WCDMA + NR 15 MHz	38.20	44.22	62.15	17.93
WCDMA + LTE 15 MHz and NR 5 MHz and NR 10 MHz + LTE 5 MHz + NR 5 MHz	35.12	41.14	62.15	21.01

Note: "and": non-contiguous channels; "+": contiguous channels

Test data, continued

Table 8.2-27: RF power density measurement results of a multi-RAT operation (SISO)

Remarks	RF Power density, dBm/MHz	EIRP limit, dBm/MHz	Margin, dB
GSM + LTE 10 MHz + NR 5 MHz	43.08	62.15	19.07
GSM + NR 10 MHz + LTE 5 MHz	42.72	62.15	19.43
GSM and LTE 5 MHz and 4×NR 5 MHz	39.77	62.15	22.38
GSM + 4×NR 5 MHz + LTE 5 MHz	41.12	62.15	21.03
GSM and WCDMA	42.03	62.15	20.12
GSM + WCDMA	42.72	62.15	19.43
GSM and LTE 15 MHz	42.59	62.15	19.56
GSM + LTE 15 MHz	42.86	62.15	19.29
GSM and NR 15 MHz	42.53	62.15	19.62
GSM + NR 15 MHz	42.77	62.15	19.38
GSM + LTE 20 MHz and NR 5 MHz and NR 10 MHz + LTE 5 MHz + NR 5 MHz	39.86	62.15	22.29
CDMA and LTE 5 MHz and 4×NR 5 MHz	38.58	62.15	23.57
CDMA and LTE 15 MHz	40.22	62.15	21.93
CDMA and NR 15 MHz	40.31	62.15	21.84
CDMA + LTE 15 MHz and NR 5 MHz and NR 10 MHz + LTE 5 MHz + NR 5 MHz	38.55	62.15	23.60
LTE 5 MHz and CDMA + NR 10 MHz	40.73	62.15	21.42
LTE 10 MHz and CDMA + NR 5 MHz	40.93	62.15	21.22
CDMA + 4×NR 5 MHz + LTE 5 MHz	39.20	62.15	22.95
CDMA + LTE 10 MHz + NR 5 MHz	41.40	62.15	20.75
CDMA + NR 10 MHz + LTE 5 MHz	41.36	62.15	20.79
CDMA + LTE 15 MHz	41.67	62.15	20.48
CDMA + NR 15 MHz	41.30	62.15	20.85

Note: "and": non-contiguous channels; "+": contiguous channels

Table 8.2-28: RF total channel power measurement results for LTE

Remarks	5 MHz channel (20 W)	10 MHz channel (40 W)	15 MHz channel (60 W)	20 MHz channel (80 W)
Low channel, QPSK	43.03	45.83	47.73	48.99
Low channel, 16-QAM	43.03	45.84	47.75	48.98
Low channel, 64-QAM	43.03	45.83	47.74	48.98
Low channel, 256-QAM	43.00	45.83	47.74	48.98
Mid channel, QPSK	42.97			48.96
Top channel, QPSK	42.93			48.93
Mid channel, 16-QAM		45.95	47.75	
Top channel, 16-QAM		45.73	47.74	
2 carriers, 16-QAM		48.39	48.48	48.52
3 carriers, 16-QAM		48.45	48.53	48.56
4 carriers, QPSK	48.00			

Note: all results in the table are in dBm units

Table 8.2-29: RF total channel power measurement results for LTE with IB or IoT

Remarks	5 MHz channel* (20 W)	10 MHz channel (40 W)	15 MHz channel (60 W)	20 MHz channel (80 W)
Low channel, QPSK	43.00 / 43.01	45.55	47.74	48.72
Mid channel, QPSK	42.97 / 42.97	45.69	47.56	48.69
Top channel, QPSK	42.94 / 42.94	45.47	47.54	48.68

Notes: *Guard-band (IB) at the bottom of the channel or at the top of the channel
All results in the table are in dBm units

Table 8.2-30: RF total channel power measurement results for NR

Remarks	5 MHz channel (20 W)	10 MHz channel (40 W)	15 MHz channel (60 W)	20 MHz channel (80 W)
Low channel, QPSK	43.03	45.82	47.73	49.00
Low channel, 16-QAM	43.04	45.83	47.76	48.99

Section 8
Test name
Specification

Testing data
Transmitter output power (EIRP) and antenna height (Band 2/25)
FCC Part 24 and RSS-133 Issue 6



Low channel, 64-QAM	42.97	45.78	47.71	48.98
Low channel, 256-QAM	43.00	45.82	47.73	48.97
Mid channel, 16-QAM		45.97	47.75	
Top channel, 16-QAM		45.76	47.73	
Mid channel, QPSK	42.99			48.94
Top channel, QPSK	42.95			48.93
2 carriers, QPSK				48.60
3 carriers, QPSK				48.61
2 carriers, 16-QAM		48.50	48.55	
3 carriers, 16-QAM		48.51	48.58	
4 carriers, 16-QAM	48.01			

Note: all results in the table are in dBm units

Test data, continued

Table 8.2-31: RF total channel power measurement results for WCDMA

Remarks	Power (dBm)
Low channel, QPSK	43.02
Low channel, 16-QAM	43.03
Low channel, 64-QAM	43.03
Mid channel, 16-QAM	42.98
Top channel, 16-QAM	42.93

Table 8.2-32: RF total channel power measurement results for CDMA

Remarks	Power (dBm)
Low channel	43.02
Mid channel	42.98
Top channel	42.94

Table 8.2-33: RF total channel power measurement results for GSM

Remarks	Power (dBm)
Low channel	42.64
Mid channel	42.74
Top channel	42.69

Table 8.2-34: RF total channel power measurement results for multi-RAT operation

Remarks	Power (dBm)
CDMA and LTE 5 MHz and 4×NR 5 MHz	48.25
GSM and LTE 5 MHz and 4×NR 5 MHz	48.32
LTE 15 MHz and CDMA	48.07
LTE 15 MHz and WCDMA	48.35
LTE 15 MHz and GSM	48.55
NR 15 MHz and WCDMA	48.49
NR 15 MHz and CDMA	48.19
NR 15 MHz and GSM	48.65
WCDMA and GSM	45.44
CDMA and LTE 5 MHz and 4×NR 5 MHz	48.49
CDMA + LTE 15 MHz and NR 5 MHz and NR 10 MHz + LTE 5 MHz + NR 5 MHz	48.10
GSM + LTE 20 MHz and NR 5 MHz and NR 10 MHz + LTE 5 MHz + NR 5 MHz	48.23
LTE 10 MHz and CDMA + NR 5 MHz	47.95
LTE 10 MHz and GSM + NR 5 MHz	47.88
LTE 10 MHz and WCDMA + NR 5 MHz	48.24
LTE 10 MHz and NR 10 MHz	48.40
NR 10 MHz and CDMA + LTE 5 MHz	48.05
NR 10 MHz and GSM + LTE 5 MHz	48.00
NR 10 MHz and WCDMA + LTE 5 MHz	48.35
WCDMA + LTE 15 MHz and NR 5 MHz and NR 10 MHz + LTE 5 MHz + NR 5 MHz	48.41

Note: "and": non-contiguous channels; "+": contiguous channels

Test data, continued



Figure 8.2-1: Output channel power of LTE 5 MHz channel bandwidth, single carrier operation, sample plot



Figure 8.2-2: Output channel power of NR 5 MHz channel bandwidth, single carrier operation, sample plot



Figure 8.2-3: Output channel power of LTE 10 MHz channel bandwidth, single carrier operation, sample plot



Figure 8.2-4: Output channel power of NR 10 MHz channel bandwidth, single carrier operation, sample plot



Figure 8.2-5: Output channel power of LTE 15 MHz channel bandwidth, single carrier operation, sample plot



Figure 8.2-6: Output channel power of NR 15 MHz channel bandwidth, single carrier operation, sample plot



Figure 8.2-7: Output channel power of LTE 20 MHz channel bandwidth, single carrier operation, sample plot



Figure 8.2-8: Output channel power of NR 20 MHz channel bandwidth, single carrier operation, sample plot

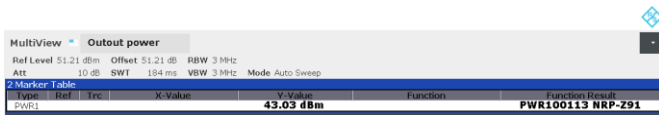

Figure 8.2-9: Output channel power of WCDMA, single carrier operation, sample plot



Figure 8.2-10: Output channel power of CDMA, single carrier operation, sample plot

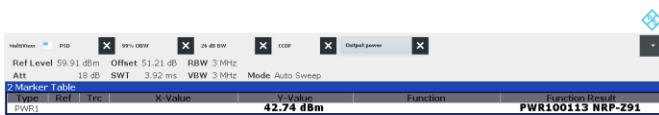

Figure 8.2-11: Output channel power of GSM, single carrier operation, sample plot



Figure 8.2-12: Output channel power of multi-RAT operation, sample plot

Test data, continued

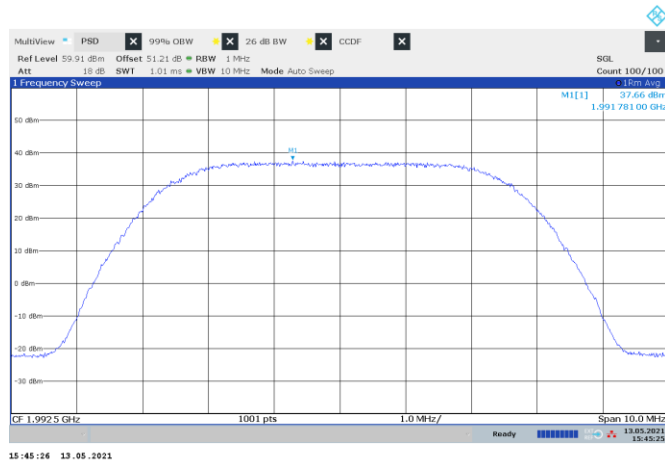

Figure 8.2-13: PSD of LTE 5 MHz channel bandwidth, single carrier operation, sample plot

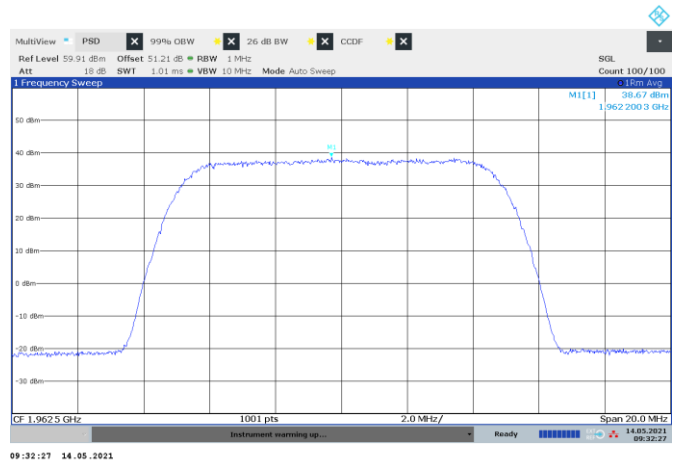

Figure 8.2-14: PSD of LTE 10 MHz channel bandwidth, single carrier operation, sample plot

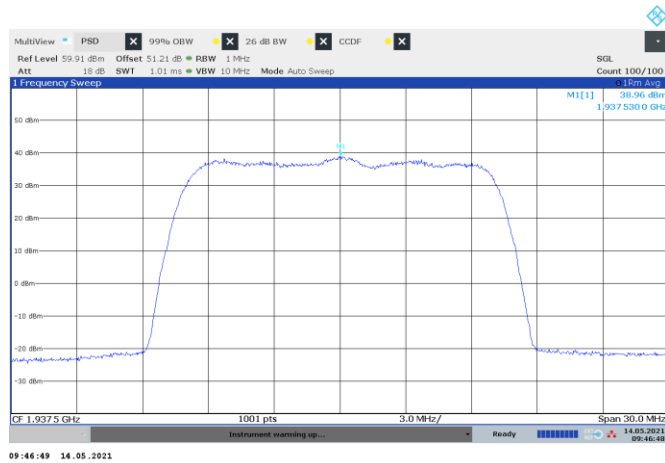

Figure 8.2-15: PSD of LTE 15 MHz channel bandwidth, single carrier operation, sample plot

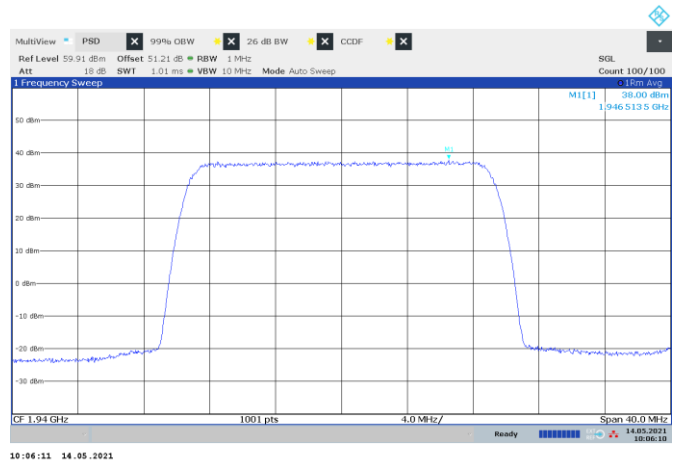

Figure 8.2-16: PSD of LTE 20 MHz channel bandwidth, single carrier operation, sample plot

Test data, continued

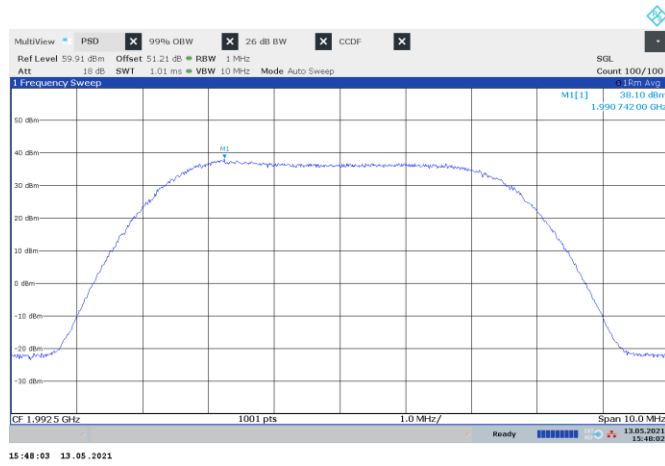

Figure 8.2-17: PSD of LTE 5 MHz channel bandwidth with guard-band, single carrier operation, sample plot

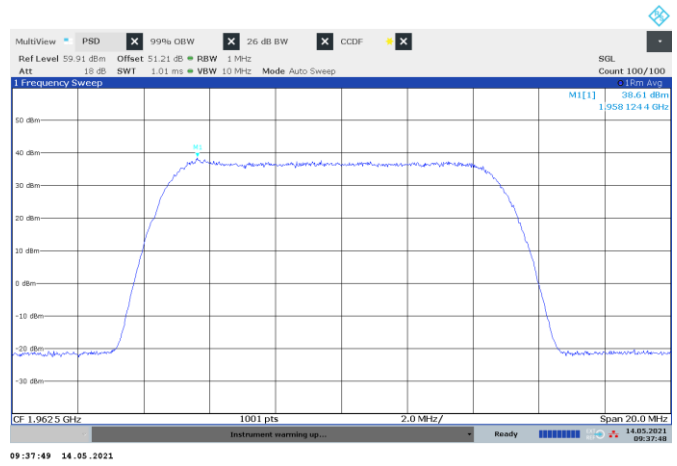

Figure 8.2-18: PSD of LTE 10 MHz channel bandwidth with IoT, single carrier operation, sample plot

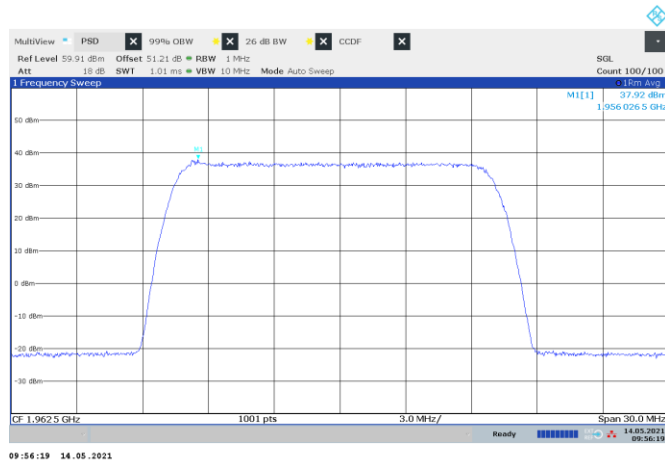

Figure 8.2-19: PSD of LTE 15 MHz channel bandwidth with IoT, single carrier operation, sample plot

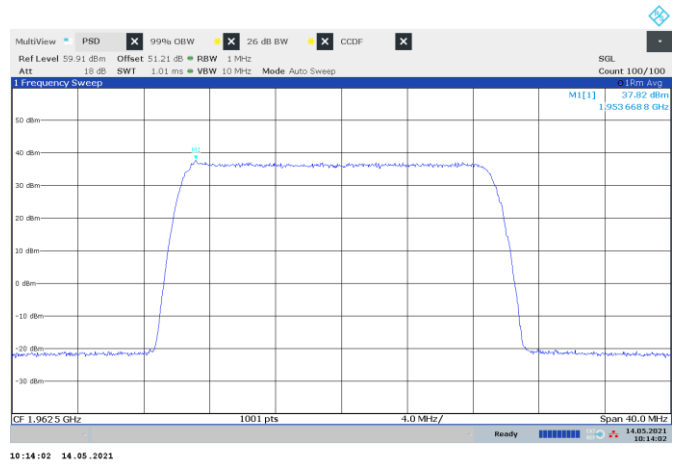

Figure 8.2-20: PSD of LTE 20 MHz channel bandwidth with IoT, single carrier operation, sample plot

Test data, continued

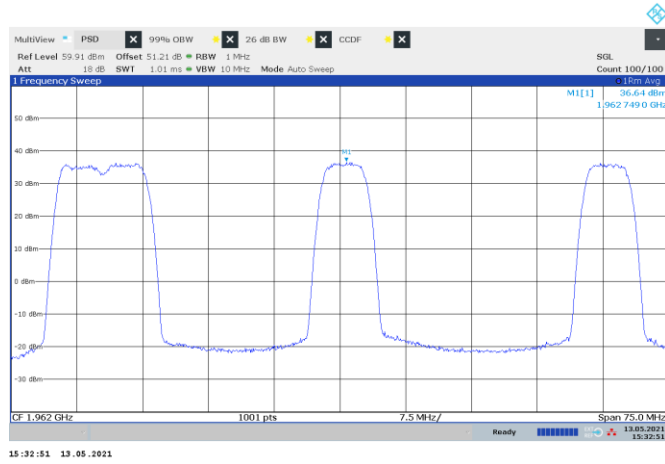

Figure 8.2-21: PSD of LTE 5 MHz channel bandwidth, multi-carrier operation, sample plot

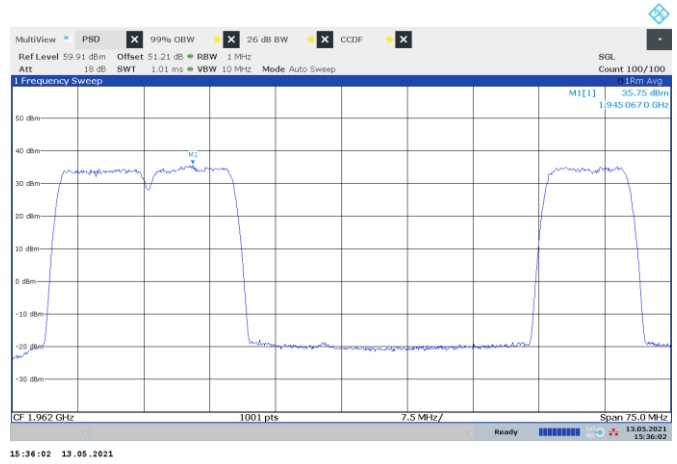

Figure 8.2-22: PSD of LTE 10 MHz channel bandwidth, multi-carrier operation, sample plot

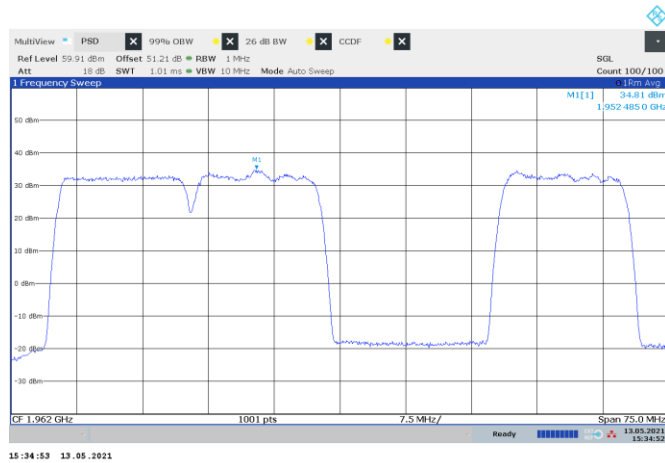

Figure 8.2-23: PSD of LTE 15 MHz channel bandwidth, multi-carrier operation, sample plot

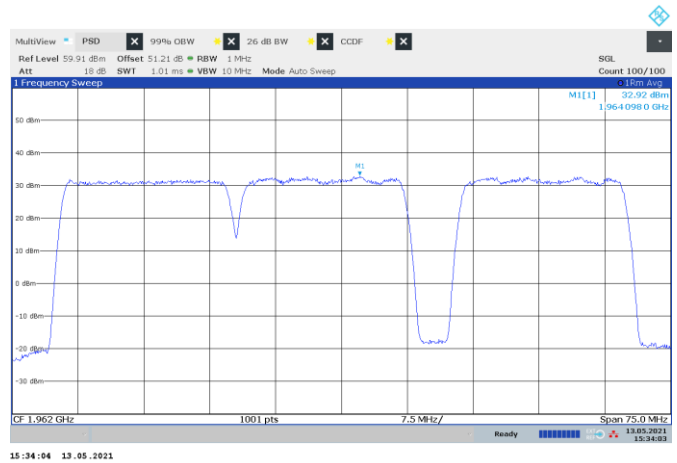

Figure 8.2-24: PSD of LTE 20 MHz channel bandwidth, multi-carrier operation, sample plot

Test data, continued

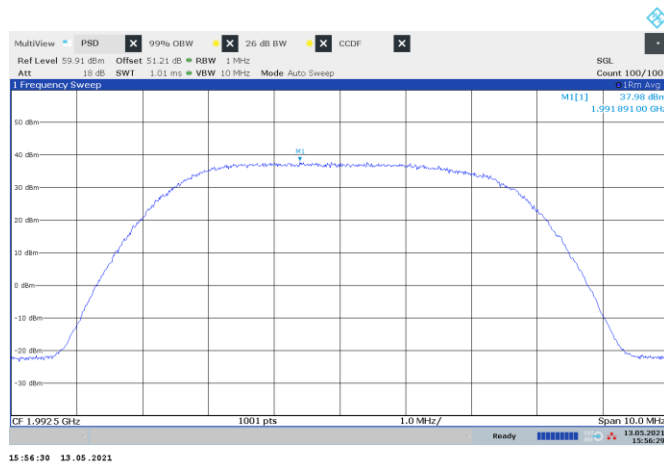

Figure 8.2-25: PSD of NR 5 MHz channel bandwidth, single carrier operation, sample plot

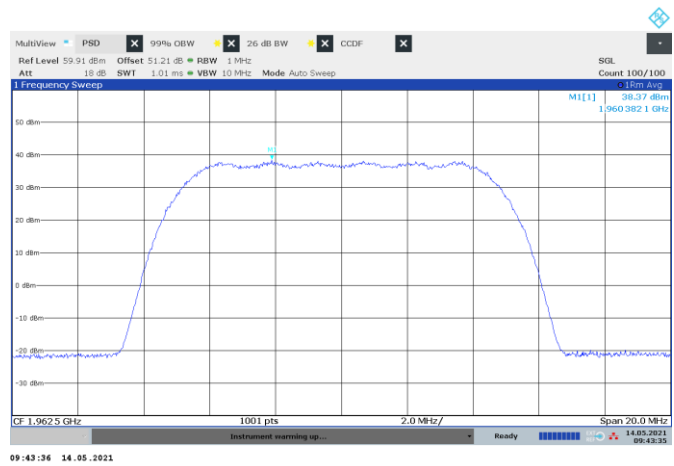

Figure 8.2-26: PSD of NR 10 MHz channel bandwidth, single carrier operation, sample plot

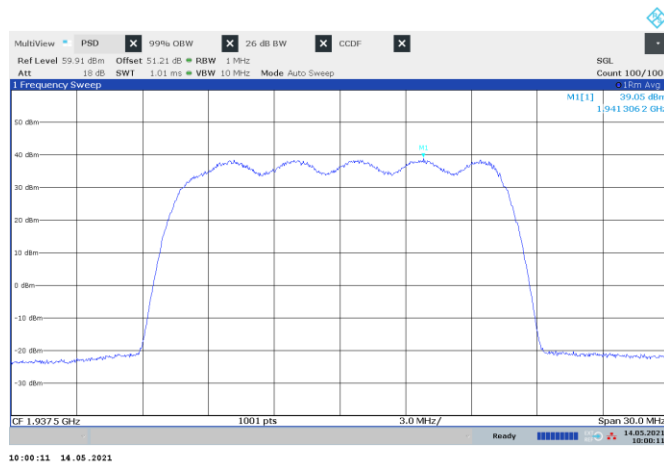

Figure 8.2-27: PSD of NR 15 MHz channel bandwidth, single carrier operation, sample plot

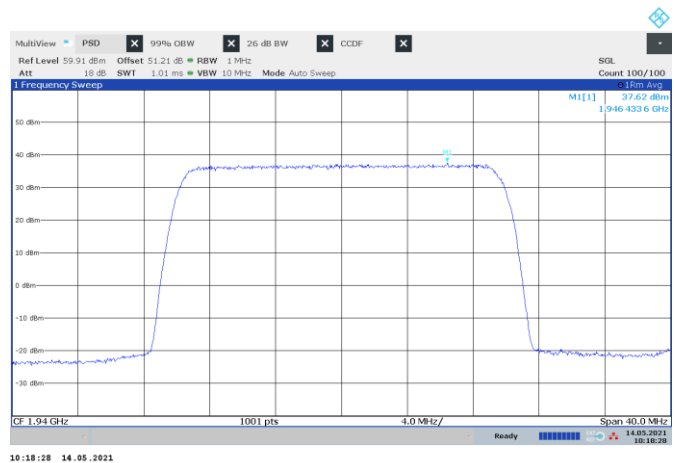

Figure 8.2-28: PSD of NR 20 MHz channel bandwidth, single carrier operation, sample plot

Test data, continued

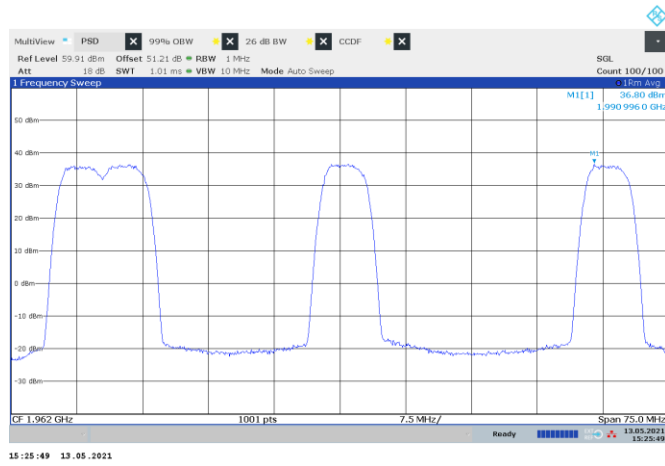

Figure 8.2-29: PSD of NR 5 MHz channel bandwidth, multi-carrier operation, sample plot

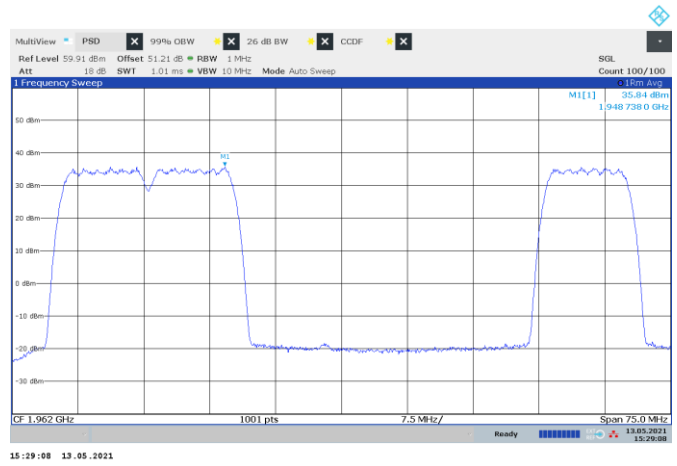

Figure 8.2-30: PSD of NR 10 MHz channel bandwidth, multi-carrier operation, sample plot

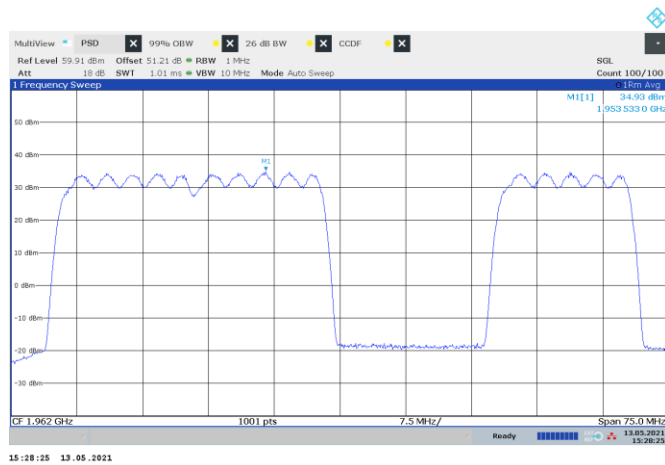

Figure 8.2-31: PSD of NR 15 MHz channel bandwidth, multi-carrier operation, sample plot

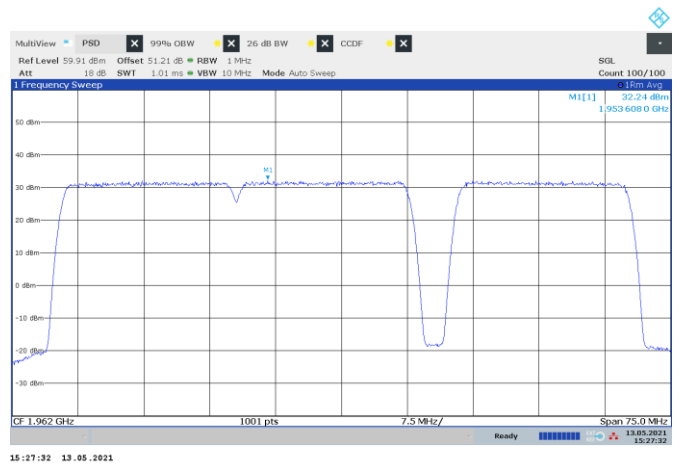

Figure 8.2-32: PSD of NR 20 MHz channel bandwidth, multi-carrier operation, sample plot

Test data, continued

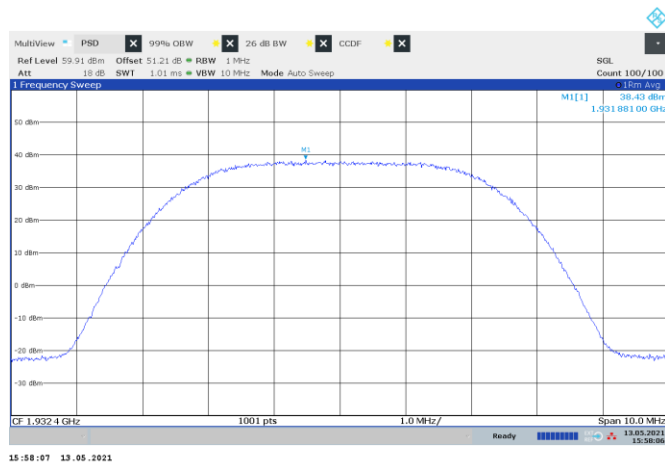

Figure 8.2-33: PSD of WCDMA, sample plot

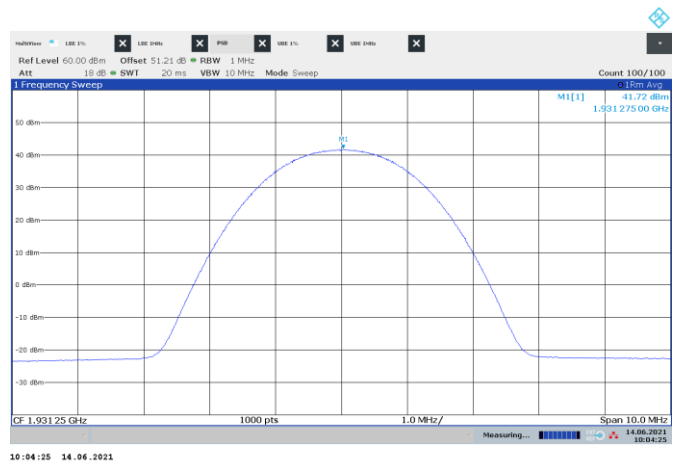

Figure 8.2-34: PSD of CDMA, sample plot

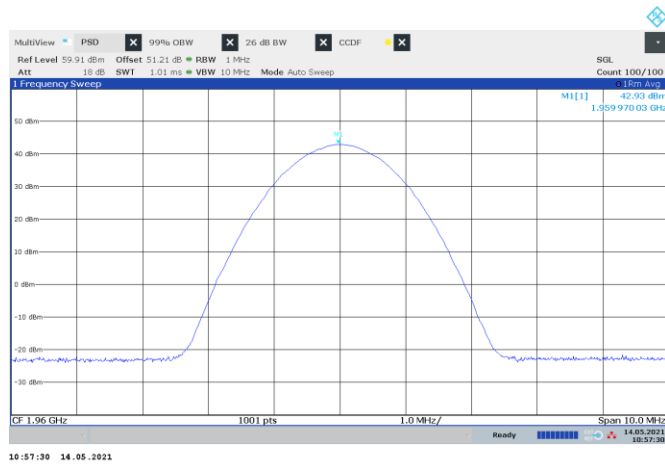

Figure 8.2-35: PSD of GSM, sample plot

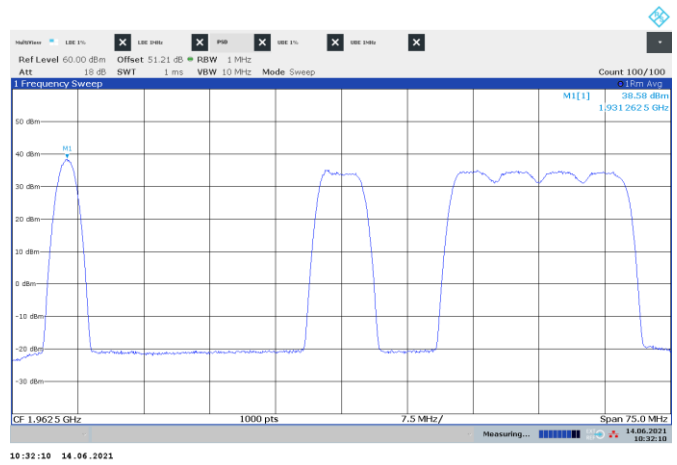

Figure 8.2-36: PSD of multi-RAT operation, CDMA and LTE 5 MHz and 4xNR 5 MHz

Test data, continued

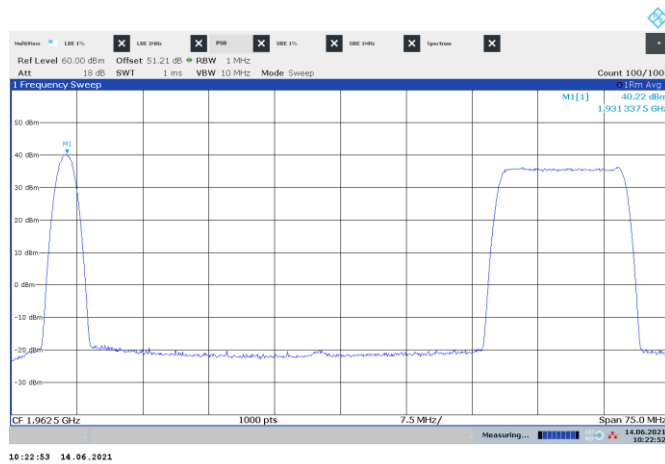

Figure 8.2-37: PSD of multi-RAT operation, CDMA and LTE 15 MHz

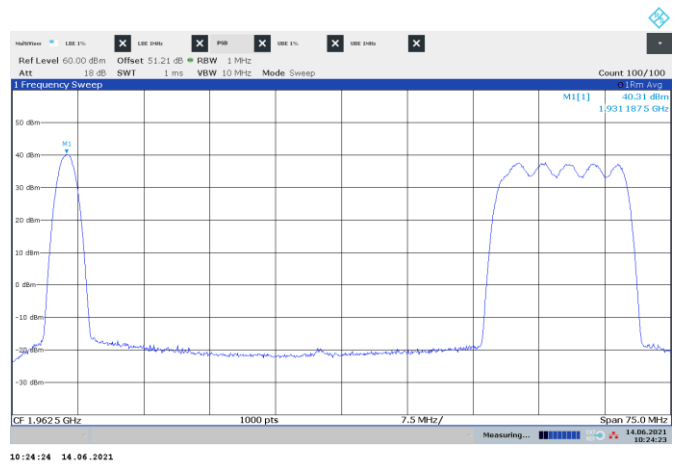

Figure 8.2-38: PSD of multi-RAT operation, CDMA and NR 15 MHz

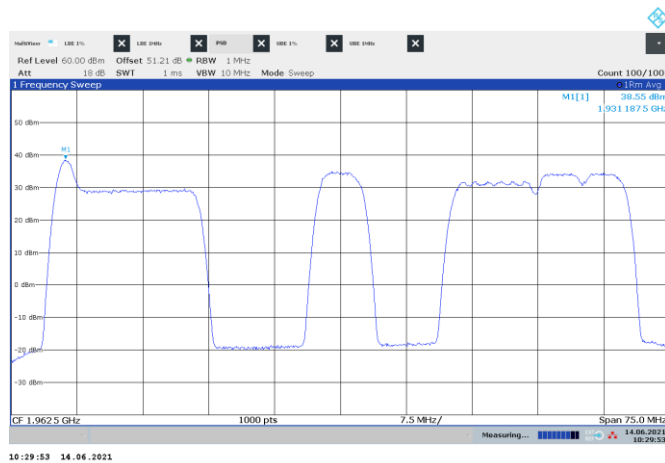

Figure 8.2-39: PSD of multi-RAT operation, CDMA + LTE 15 MHz and NR 5 MHz and NR 10 MHz + LTE 5 MHz

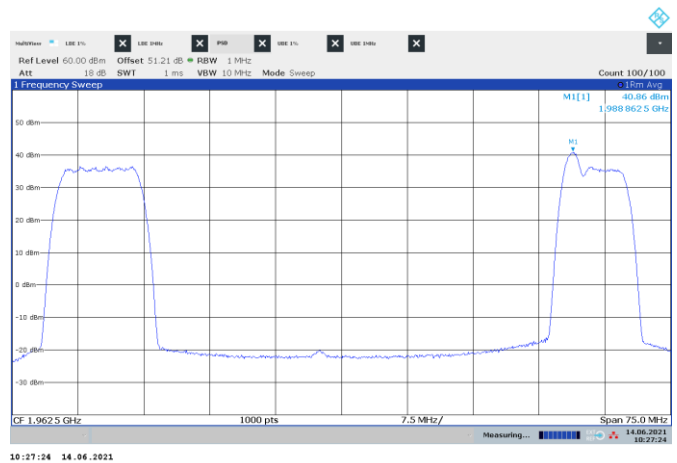

Figure 8.2-40: PSD of multi-RAT operation, NR 10 MHz and CDMA + LTE 5 MHz

Test data, continued

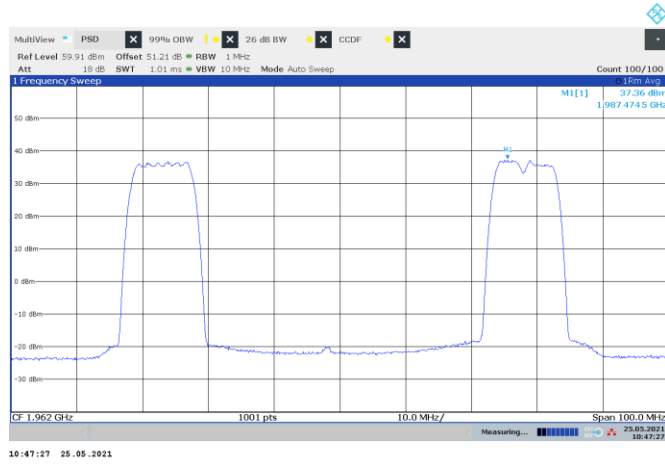

Figure 8.2-41: PSD of multi-RAT operation, LTE 5 MHz and WCDMA and NR 10 MHz

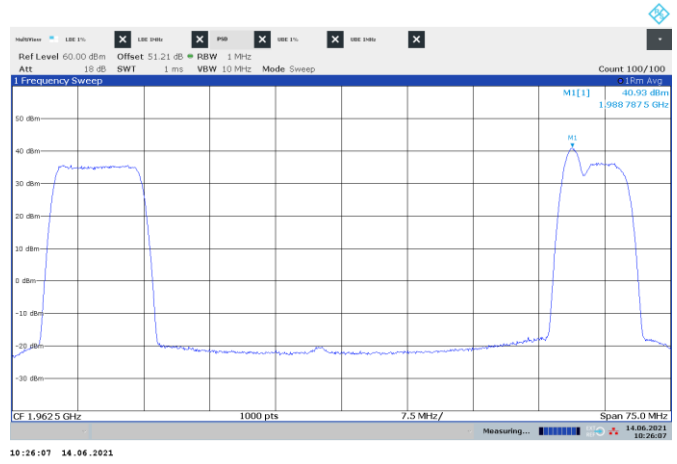

Figure 8.2-42: PSD of multi-RAT operation, LTE 10 MHz and CDMA + NR 5 MHz

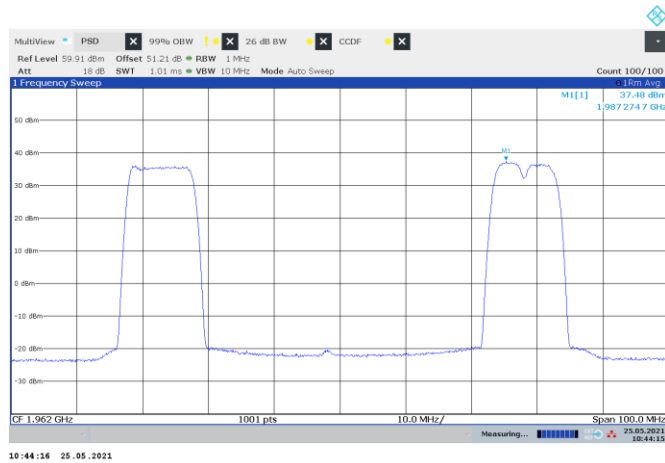

Figure 8.2-43: PSD of multi-RAT operation, LTE 10 MHz and WCDMA and NR 5 MHz

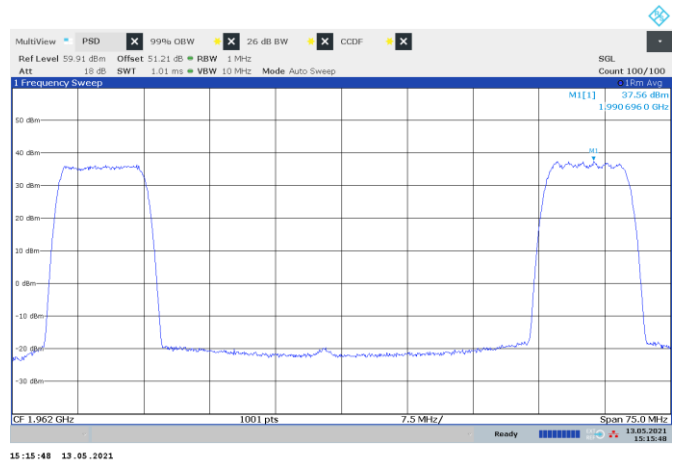

Figure 8.2-44: PSD of multi-RAT operation, LTE 10 MHz and NR 10 MHz

Test data, continued

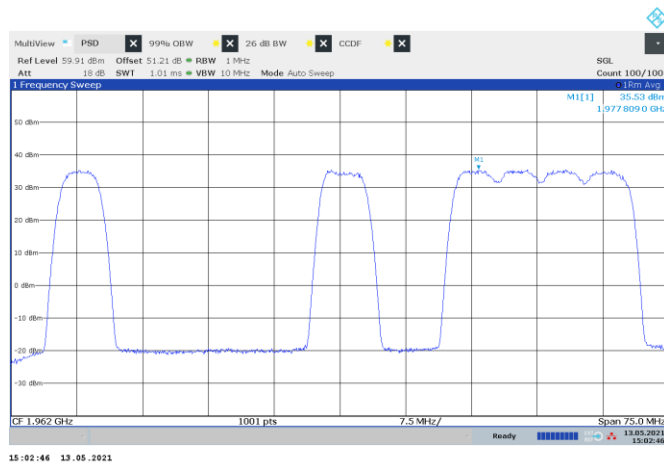

Figure 8.2-45: PSD of multi-RAT operation, WCDMA and LTE 5 MHz and 4xNR 5 MHz

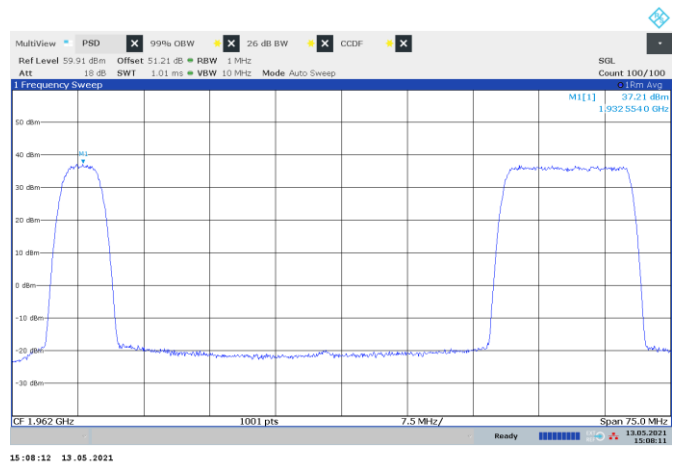

Figure 8.2-46: PSD of multi-RAT operation, WCDMA and LTE 15 MHz

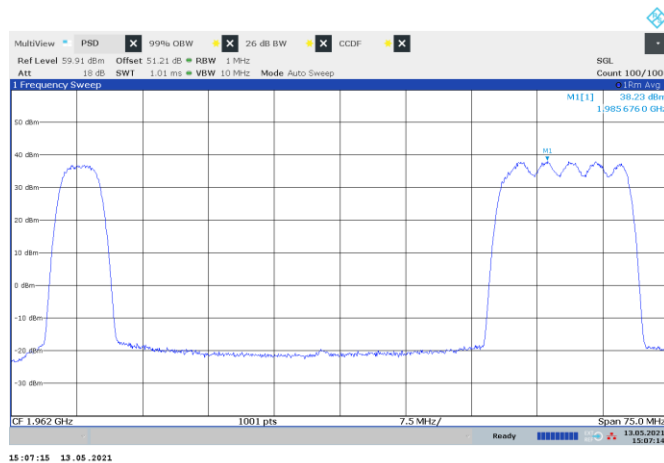

Figure 8.2-47: PSD of multi-RAT operation, WCDMA and NR 15 MHz

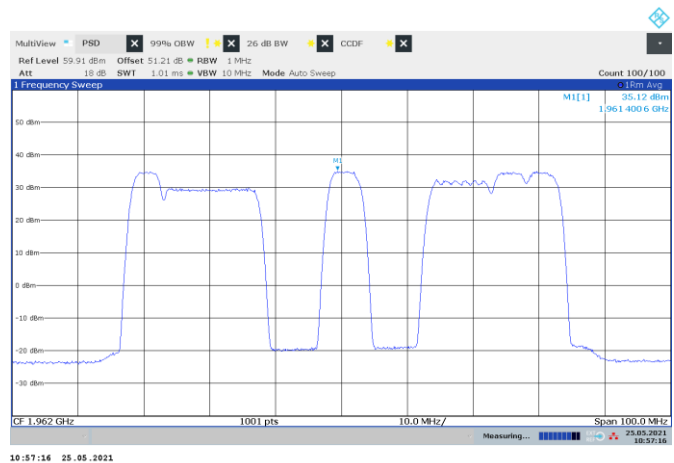

Figure 8.2-48: PSD of multi-RAT operation, WCDMA + LTE 15 MHz and NR 5 MHz and NR 10 MHz + LTE 5 MHz + NR 5 MHz

Test data, continued

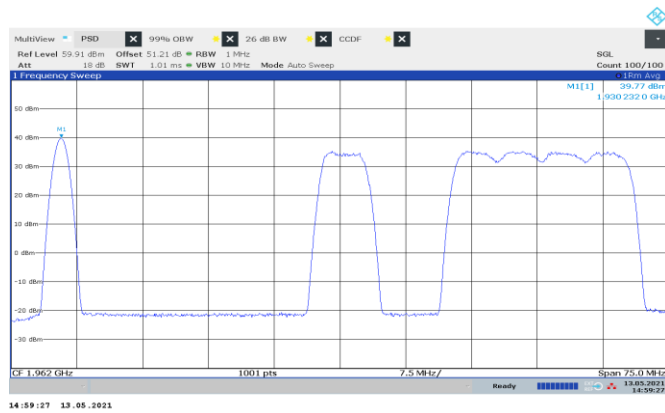

Figure 8.2-49: PSD of multi-RAT operation, GSM and LTE 5 MHz and 4xNR 5 MHz

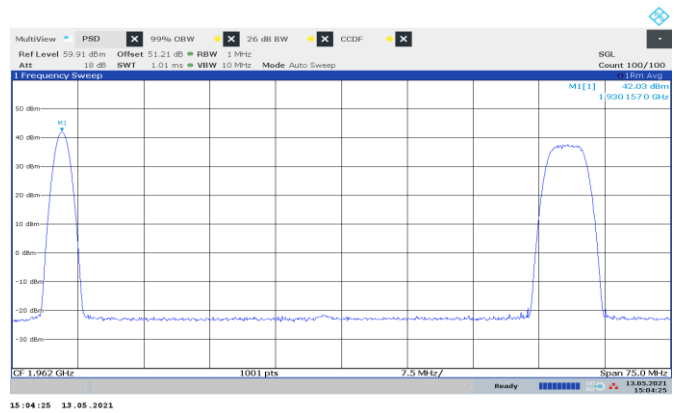

Figure 8.2-50: PSD of multi-RAT operation, GSM and WCDMA

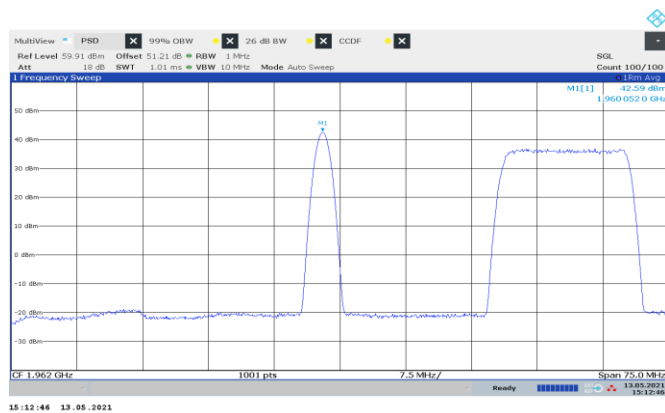

Figure 8.2-51: PSD of multi-RAT operation, GSM and LTE 15 MHz

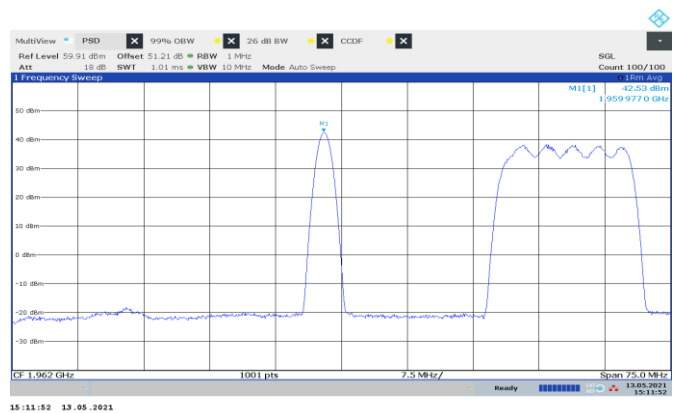

Figure 8.2-52: PSD of multi-RAT operation, GSM and NR 15 MHz



Figure 8.2-53: PSD of multi-RAT operation, GSM + LTE 20 MHz and NR 5 MHz and NR 10 MHz + LTE 5 MHz + NR 5 MHz

Test data, continued

Table 8.2-35: Complementary Cumulative Distribution Function (CCDF) of the PAPR reduction measurement results for single carrier operation for LTE 5 MHz

Remarks	Frequency, MHz	0.1% CCDF, dB	PAPR reduction limit, dB	Margin, dB
5 MHz, Low channel	1932.5	8.40	13.00	4.60
5 MHz, Mid channel	1962.5	8.34	13.00	4.66
5 MHz, Top channel	1992.5	8.38	13.00	4.62
5 MHz with guard-band (IB), Low	1932.5	8.36	13.00	4.64
5 MHz with guard-band (IB), Mid	1962.5	8.28	13.00	4.72
5 MHz with guard-band (IB), Top	1992.5	8.32	13.00	4.68

Table 8.2-36: Complementary Cumulative Distribution Function (CCDF) of the PAPR reduction measurement results for single carrier operation for LTE 10 MHz

Remarks	Frequency, MHz	0.1% CCDF, dB	PAPR reduction limit, dB	Margin, dB
10 MHz, Low channel	1935.0	8.36	13.00	4.64
10 MHz, Mid channel	1962.5	8.32	13.00	4.68
10 MHz, Top channel	1990.0	8.32	13.00	4.68
10 MHz with IoT, Low channel	1935.0	8.38	13.00	4.62
10 MHz with IoT, Mid channel	1962.5	8.34	13.00	4.66
10 MHz with IoT, Top channel	1990.0	8.34	13.00	4.66

Table 8.2-37: Complementary Cumulative Distribution Function (CCDF) of the PAPR reduction measurement results for single carrier operation for LTE 15 MHz

Remarks	Frequency, MHz	0.1% CCDF, dB	PAPR reduction limit, dB	Margin, dB
15 MHz, Low channel	1937.5	8.24	13.00	4.76
15 MHz, Mid channel	1962.5	8.22	13.00	4.78
15 MHz, Top channel	1987.5	8.22	13.00	4.78
15 MHz with IoT, Low channel	1937.5	8.18	13.00	4.82
15 MHz with IoT, Mid channel	1962.5	8.16	13.00	4.84
15 MHz with IoT, Top channel	1987.5	8.18	13.00	4.82

Table 8.2-38: Complementary Cumulative Distribution Function (CCDF) of the PAPR reduction measurement results for single carrier operation for LTE 20 MHz

Remarks	Frequency, MHz	0.1% CCDF, dB	PAPR reduction limit, dB	Margin, dB
20 MHz, Low channel	1940.0	8.10	13.00	4.90
20 MHz, Mid channel	1962.5	8.06	13.00	4.94
20 MHz, Top channel	1985.0	8.06	13.00	4.94
20 MHz with IoT, Low channel	1940.0	8.12	13.00	4.88
20 MHz with IoT, Mid channel	1962.5	8.12	13.00	4.88
20 MHz with IoT, Top channel	1985.0	8.08	13.00	4.92

Table 8.2-39: Complementary Cumulative Distribution Function (CCDF) of the PAPR reduction measurement results for single carrier operation for WCDMA

Remarks	Frequency, MHz	0.1% CCDF, dB	PAPR reduction limit, dB	Margin, dB
Low channel	1932.4	7.34	13.00	5.66
Mid channel	1960.0	7.32	13.00	5.68
Top channel	1987.6	7.36	13.00	5.64

Table 8.2-40: Complementary Cumulative Distribution Function (CCDF) of the PAPR reduction measurement results for single carrier operation for CDMA

Remarks	Frequency, MHz	0.1% CCDF, dB	PAPR reduction limit, dB	Margin, dB
Low channel	1931.875	7.42	13.00	5.58
Mid channel	1960.000	7.38	13.00	5.62
Top channel	1988.125	7.42	13.00	5.58

Test data, continued

Table 8.2-41: Complementary Cumulative Distribution Function (CCDF) of the PAPR reduction measurement results for single carrier operation for GSM

Remarks	Frequency, MHz	0.1% CCDF, dB	PAPR reduction limit, dB	Margin, dB
Low channel	1930.2	7.52	13.00	5.48
Mid channel	1960.0	7.52	13.00	5.48
Top channel	1989.8	8.32	13.00	4.68

Table 8.2-42: Complementary Cumulative Distribution Function (CCDF) of the PAPR reduction measurement results for single carrier operation for NR 5 MHz

Remarks	Frequency, MHz	0.1% CCDF, dB	PAPR reduction limit, dB	Margin, dB
Low channel	1932.5	8.30	13.00	4.70
Mid channel	1962.5	8.24	13.00	4.76
Top channel	1992.5	8.28	13.00	4.72

Table 8.2-43: Complementary Cumulative Distribution Function (CCDF) of the PAPR reduction measurement results for single carrier operation for NR 10 MHz

Remarks	Frequency, MHz	0.1% CCDF, dB	PAPR reduction limit, dB	Margin, dB
Low channel	1935.0	8.54	13.00	4.46
Mid channel	1962.5	8.76	13.00	4.24
Top channel	1990.0	8.60	13.00	4.40

Table 8.2-44: Complementary Cumulative Distribution Function (CCDF) of the PAPR reduction measurement results for single carrier operation for NR 15 MHz

Remarks	Frequency, MHz	0.1% CCDF, dB	PAPR reduction limit, dB	Margin, dB
Low channel	1937.5	8.34	13.00	4.66
Mid channel	1962.5	8.46	13.00	4.54
Top channel	1987.5	8.26	13.00	4.74

Table 8.2-45: Complementary Cumulative Distribution Function (CCDF) of the PAPR reduction measurement results for single carrier operation for NR 20 MHz

Remarks	Frequency, MHz	0.1% CCDF, dB	PAPR reduction limit, dB	Margin, dB
Low channel	1940.0	8.48	13.00	4.52
Mid channel	1962.5	8.18	13.00	4.82
Top channel	1985.0	8.04	13.00	4.96



Figure 8.2-54: CCDF sample plot, LTE

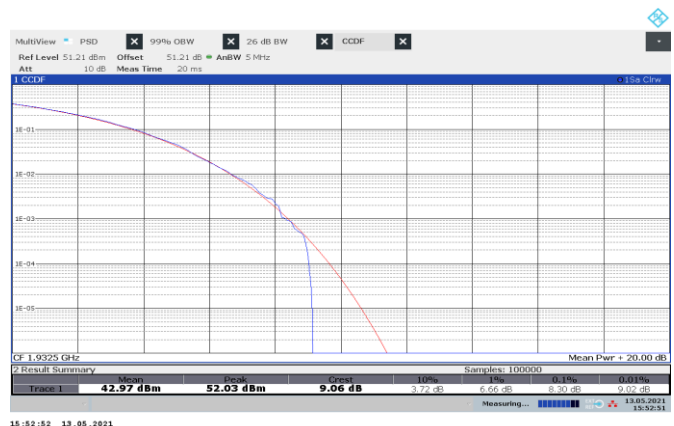

Figure 8.2-55: CCDF sample plot, NR



Figure 8.2-56: CCDF sample plot, CDMA

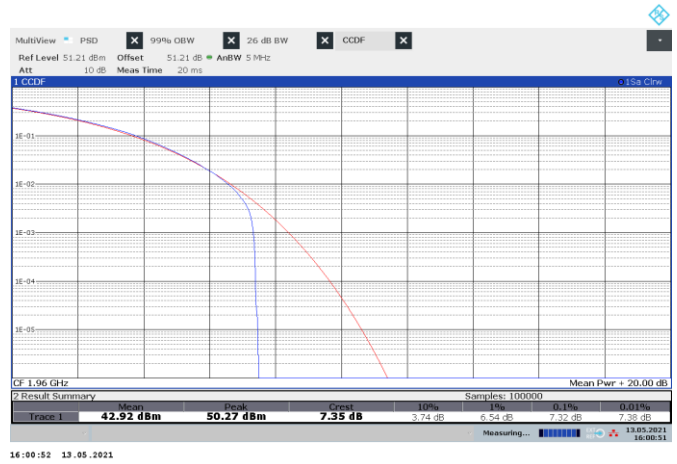

Figure 8.2-57: CCDF sample plot, WCDMA

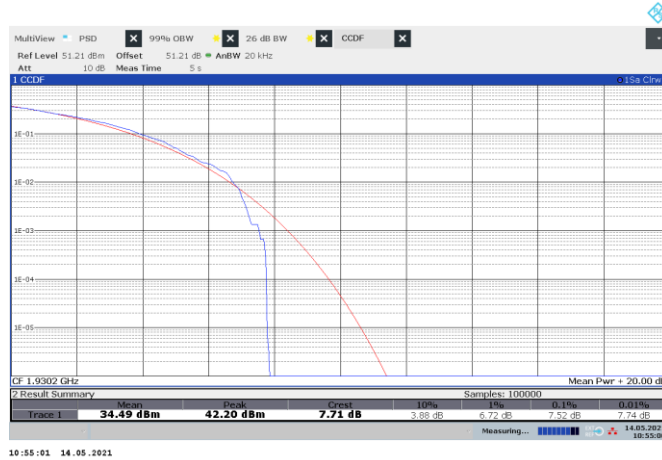

Figure 8.2-58: CCDF sample plot, GSM

8.3 Spurious emissions at RF antenna connector (Band 66)

8.3.1 Definitions and limits

FCC §27.53:

(h) AWS emission limits

(1) General protection levels. Except as otherwise specified below, for operations in the 1695–1710 MHz, 1710–1755 MHz, 1755–1780 MHz, 1915–1920 MHz, 1995–2000 MHz, 2000–2020 MHz, 2110–2155 MHz, 2155–2180 MHz, and 2180–2200 bands, the power of any emission outside a licensee's frequency block shall be attenuated below the transmitter power (P) in watts by at least $43 + 10 \log_{10}(P)$ dB.

(3) Measurement procedure.

(i) Compliance with this provision is based on the use of measurement instrumentation employing a resolution bandwidth of 1 megahertz or greater. However, in the 1-megahertz bands immediately outside and adjacent to the licensee's frequency block, a resolution bandwidth of at least one percent of the emission bandwidth of the fundamental emission of the transmitter may be employed. The emission bandwidth is defined as the width of the signal between two points, one below the carrier center frequency and one above the carrier center frequency, outside of which all emissions are attenuated at least 26 dB below the transmitter power.

(ii) When measuring the emission limits, the nominal carrier frequency shall be adjusted as close to the licensee's frequency block edges, both upper and lower, as the design permits.

(iii) The measurements of emission power can be expressed in peak or average values, provided they are expressed in the same parameters as the transmitter power.

RSS-139, Section 6.6:

i. In the first 1.0 MHz bands immediately outside and adjacent to the equipment's smallest operating frequency block, which can contain the equipment's occupied bandwidth, the emission power per any 1% of the emission bandwidth shall be attenuated below the transmitter output power P (in dBW) by at least $43 + 10 \log_{10} p$ (watts) dB.

ii. After the first 1.0 MHz outside the equipment's smallest operating frequency block, which can contain the equipment's occupied bandwidth, the emission power in any 1 MHz bandwidth shall be attenuated below the transmitter output power P (in dBW) by at least $43 + 10 \log_{10} p$ (watts) dB.

RSS-170, Section 5.4:

The transmitter unwanted emissions shall be measured for all channel bandwidths with the carrier frequency set at both the highest and lowest channels in which the equipment is designed to operate.

The e.i.r.p. density of unwanted and carrier-off state emissions outlined in this section (Section 5.4) shall be averaged over any 2-ms active transmission using an RMS detector with a resolution bandwidth of 1 MHz for broadband emissions and a resolution bandwidth of 1 kHz for discrete emissions, unless stated otherwise.

For ATC equipment operating in the bands 2000–2020 MHz and 2180–2200 MHz, the unwanted emission limits shall be determined using a measurement bandwidth of 1 MHz or greater. However, in the 1 MHz band immediately outside and adjacent to the equipment's operating frequency block, a resolution bandwidth of at least 1% of the occupied bandwidth may be employed.

5.4.1.2 ATC Base Station Equipment operating in bands 2000–2020 MHz and 2180–2200 MHz

The unwanted emissions of ATC base station equipment transmitting in the bands 2000–2020 MHz and 2180–2200 MHz shall comply with the following:

(1) The power of any unwanted emissions at frequencies outside the equipment's operating frequency block shall be attenuated below the transmitter power P (dBW), by $43 + 10 \log p$ (watts), dB.

(2) *For equipment operating in the band 2180–2200 MHz, in addition to (1), the power of any emissions on all frequencies between 2200 MHz and 2290 MHz shall not exceed an e.i.r.p. of -100.6 dBW/4 kHz (-70.6 dBm/4 kHz).

*** This requirement is for implementation and is enforced at the time of licensing. Therefore, results are not included in this report.**

Requirement number 2 above is amended as detailed in the following ISED document...

<https://www.ic.gc.ca/eic/site/smt-gst.nsf/eng/sf11536.html>

8.3.2 Test summary

Test date	May 17, 2021
Test engineer	Andrey Adelberg

8.3.3 Observations, settings and special notes

- The spectrum was searched from 30 MHz to the 10th harmonic.
- All measurements were performed using an average (RMS) detector per ANSI C63.26 Paragraph 5.7.2 method.
- Limit line (43 + 10 log₁₀(P) or -13 dBm) was adjusted for MIMO operation by 6 dB*: -13 dBm - 6 dB = -19 dBm
 *MIMO correction factor for 4 antenna ports: 10 × Log₁₀(4) = 6 dB
- RBW 1 MHz, VBW was wider than RBW.
- On the conducted spurious emissions plots “FAIL” levels belong to either fundamental frequency or band edges, which were re-measured further down in the report.

8.3.4 Test data



13:46:08 17.05.2021

Figure 8.3-1: Conducted spurious emissions of LTE 5 MHz low channel, single carrier operation

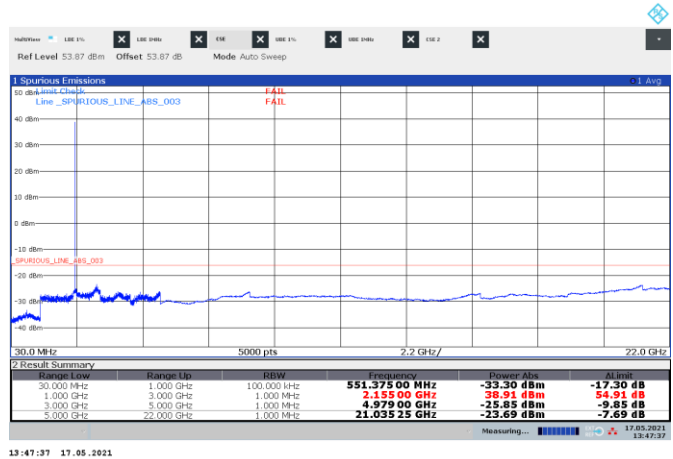

13:47:37 17.05.2021

Figure 8.3-2: Conducted spurious emissions of LTE 5 MHz mid channel, single carrier operation

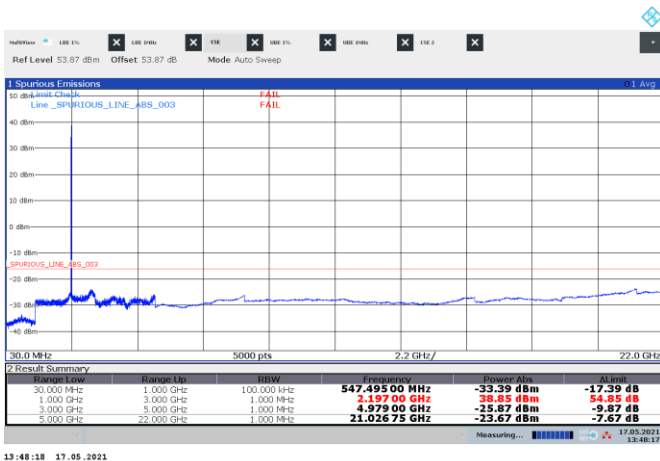

13:48:18 17.05.2021

Figure 8.3-3: Conducted spurious emissions of LTE 5 MHz top channel, single carrier operation

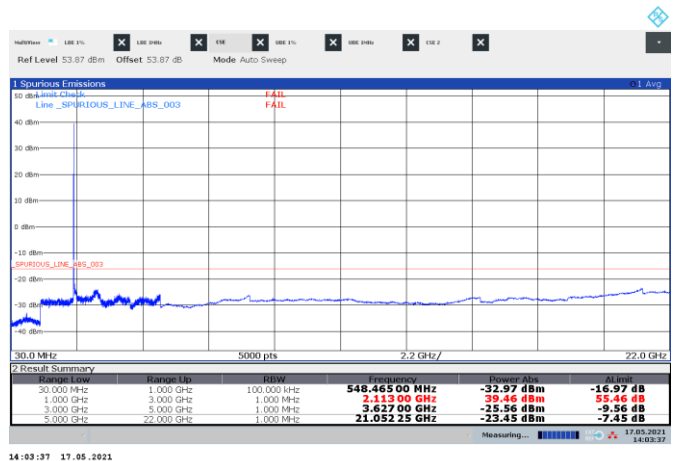

14:03:37 17.05.2021

Figure 8.3-4: Conducted spurious emissions of LTE 10 MHz low channel, single carrier operation

Test data, continued

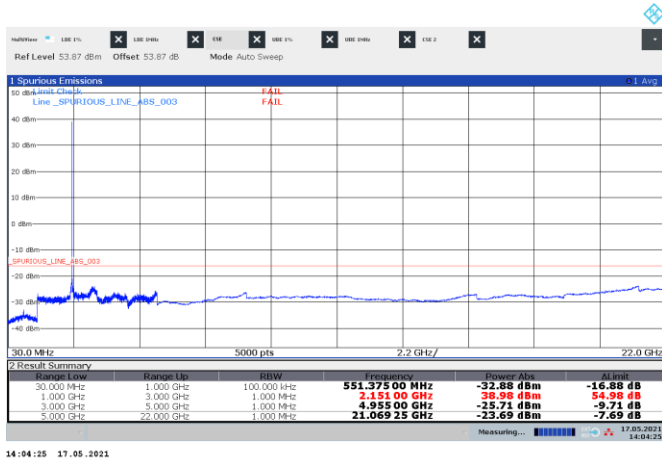

Figure 8.3-5: Conducted spurious emissions of LTE 10 MHz mid channel, single carrier operation

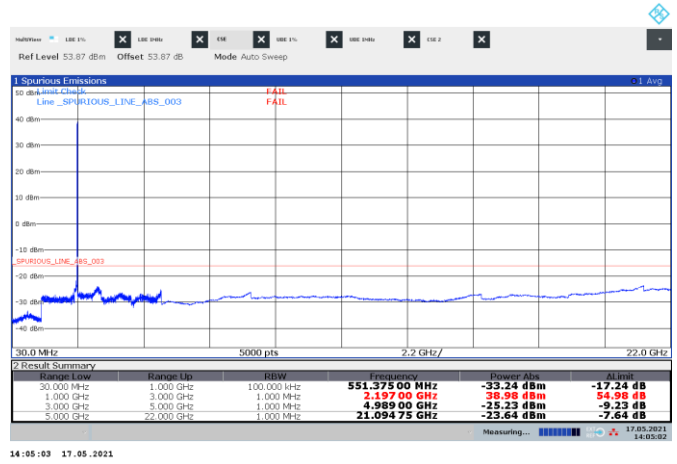

Figure 8.3-6: Conducted spurious emissions of LTE 10 MHz top channel, single carrier operation

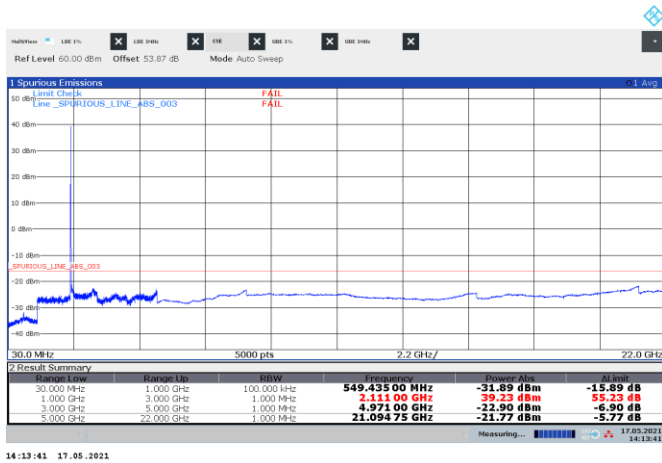

Figure 8.3-7: Conducted spurious emissions of LTE 15 MHz low channel, single carrier operation

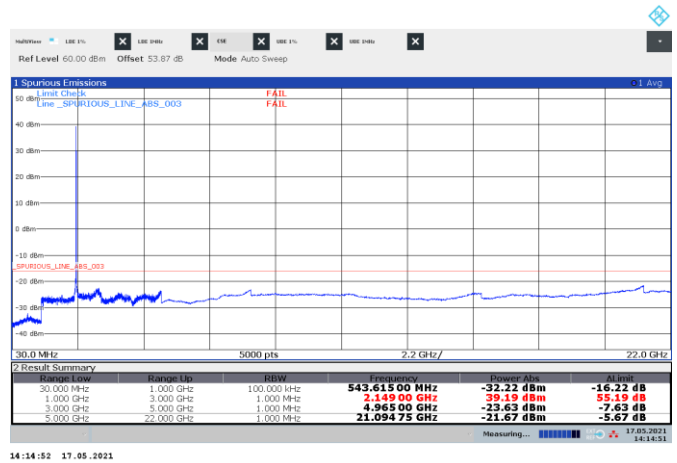

Figure 8.3-8: Conducted spurious emissions of LTE 15 MHz mid channel, single carrier operation