



**Add value.
Inspire trust.**

Report On

FCC Testing of the
Ericsson Remote Radio Unit NR, LTE and NB-IoT KRC 161 887/1,
LPRU 4410 B5 B13 (700 MHz and 850 MHz), with compatible Main
Unit in a Base Station configuration in accordance with FCC CFR 47
Part 2, FCC CFR 47 Part 22, and FCC CFR Part 27

COMMERCIAL-IN-CONFIDENCE

FCC: TA8AKRC161887-1

PREPARED BY

Handwritten signature of Glen Westwell.

Glen Westwell
Senior Test Engineer

APPROVED BY

Handwritten signature of Scott Drysdale.

Scott Drysdale
Authorised Signatory

DATED

April 23, 2020



CONTENTS

Section	Page No
1	REPORT INFORMATION 2
1.1	Report Details 3
1.2	Brief Summary of Results 4
1.3	Configuration Hescription 5
1.4	Declaration of Build Status 6
1.5	Product Information 7
1.6	Test Setup 8
1.7	Test Conditions 9
1.8	Deviation From The Standard 9
1.9	Modification Record 9
1.10	Additional Information Error! Bookmark not defined.
2	TEST DETAILS 10
2.1	Maximum Peak Output Power and Peak to Average Ratio – Conducted 11
2.2	Occupied Bandwidth 107
2.3	Band Edge 150
2.4	Transmitter Spurious Emissions 214
2.5	Frequency Stability 297
3	TEST EQUIPMENT USED 298
3.1	Test Equipment Used 299
3.2	Measurement Uncertainty 300
4	ACCREDITATION, DISCLAIMERS AND COPYRIGHT 301
4.1	Accreditation, Disclaimers and Copyright 302
ANNEX A	Module Lists A.2



SECTION 1

REPORT INFORMATION



1.1 REPORT DETAILS

Manufacturer	Ericsson
Address	Torshamnsgatan 23 Kista SE-16480 Stockholm Sweden
Product Name & Product Number	LPRU 4410 B5 B13 & KRC 161 887/1
Serial Number(s)	TD3F057135
Software Version	CXP9013268%17_R82DD
Hardware Version	R1A
Test Specification/Issue/Date	FCC CFR 47 Part 2: 2019 FCC CFR 47 Part 22: 2019 FCC CFR 47 Part 27: 2019
Test Plan	LRPU 4410 B5B13_RA_testplan_NR_LTE (TUV SUD) – 31 March 2020
Start of Test	04 February 2020
Finish of Test	02 April 2020
Name of Engineer(s)	Scott Drysdale Glen Westwell
TUV SUD Canada number	7169007217
Related Document(s)	KDB 971168 D01 v02r02 KDB 662911 D01 v02r01

ENGINEERING STATEMENT

The measurements shown in this report were made in accordance with the procedures described on test pages. All reported testing was carried out on a sample equipment to demonstrate compliance with FCC CFR 47 Part 22& 27. The sample tested was found to comply with the requirements defined in the applied rules.

Test Engineer(s);

Scott Drysdale

Glen Westwell



1.2 BRIEF SUMMARY OF RESULTS

A brief summary of results for each configuration, in accordance with FCC CFR 47 Part 2, FCC CFR 47 Part 22 and FCC CFR 47 Part 27 are shown below.

Section	Specification Clause		Test Description	Result
	FCC CFR 47 Part 2	FCC CFR 47 Part 22		
2.1	2.1046	22.913 (a)	Maximum Peak Output Power and Peak to Average Ratio - Conducted	Pass
2.2	2.1049	22.917	Occupied Bandwidth	Pass
2.3	2.1051	22.917	Band Edge	Pass
2.4	2.1051	22.917	Transmitter Spurious Emissions	Pass
2.5	2.1055	-	Frequency Stability	Pass

Section	Specification Clause		Test Description	Result
	FCC CFR 47 Part 2	FCC CFR 47 Part 27		
2.1	2.1046	27.50	Maximum Peak Output Power and Peak to Average Ratio - Conducted	Pass
2.2	2.1049	27.53	Occupied Bandwidth	Pass
2.3	2.1051	27.53 (c)	Band Edge	Pass
2.4	2.1051	27.53 (c)	Transmitter Spurious Emissions	Pass
2.5	2.1055	27.54	Frequency Stability	Pass

Measurement Uncertainty Decision Statement

Determination of conformity with the specification limits is based on the results of the compliance measurement and does not take into account measurement instrumentation uncertainty as defined in ANSI C63.26:2015 Clause 1.3.



1.3 CONFIGURATION DESCRIPTION

Configuration A-F=B5 G-H=B13	RAT	No. Of carriers	Carrier Bandwidth	Carrier Frequency Configuration (MHz)		
				Bottom	Middle	Top
A	LTE	1	5 MHz	871.5	881.5	891.5
			10 MHz	874	881.5	889
B	LTE	5	5 MHz	871.5 + 876.5 + 881.5 + 886.5 + 891.5	-	871.5 + 876.5 + 881.5 + 886.5 + 891.5
C	NR	1	5 MHz – SCS 15kHz	871.5	881.5	891.5
			10 MHz – SCS 15kHz	874	881.5	889
			15 MHz – SCS 15kHz	876.5	881.5	886.5
			20 MHz – SCS 15kHz	879	881.5	884
D	NR	2	5 MHz – SCS 15kHz	871.5 + 876.5	879 + 894	886.5 + 891.5
			10 MHz – SCS 15kHz	874 + 884	874 + 889	879 + 889
E	LTE(5MHz) + 2NR(5MHz)	3	15 MHz – SCS 15kHz	876.5	881.5	886.5
F	LTE(NB-IoT 10 MHz) + NR(10 MHz)	3	20 MHz – SCS 15kHz	879	881.5	884
G	LTE	1	5 MHz	748.5	751	753.5
			10 MHz	751	751	751
H	LTE	2	5 MHz	748.5 + 753.5	748.5 + 753.5	748.5 + 753.5



1.4 DECLARATION OF BUILD STATUS

MAIN EUT	
MANUFACTURING DESCRIPTION	LPRU 4410 B5B13
MANUFACTURER	Ericsson
TYPE	Remote Radio Base Station
PART NUMBER	KRC 161 887/1
SERIAL NUMBER	TD3F057135
HARDWARE VERSION	R1A
SOFTWARE VERSION	CXP9013268%17_R82DD
TRANSMITTER OPERATING RANGE	B5: 869-894 MHz, B13: 746-756MHz
RECEIVER OPERATING RANGE	B5: 824-849 MHz, B13: 777-787MHz
COUNTRY OF ORIGIN	China
INTERMEDIATE FREQUENCIES	None
EMISSION DESIGNATOR(S): (i.e. G1D, GXW)	B5 and B13 LTE: 5M00W7D, 10M0W7D B5 and B13 NBloT Guardband: 10M0W7D B5 NR: 5M00F9W, 10M0F9W, 15M0F9W, 20M0F9W
MODULATION TYPES: (i.e. GMSK, QPSK)	LTE: QPSK, 16QAM, 64QAM, 256QAM NR: QPSK, 16QAM, 64QAM, 256QAM
HIGHEST INTERNALLY GENERATED FREQUENCY	0.894 GHz
OUTPUT POWER (W or dBm)	B5: 4 x 0.05W (17dBm) B13: 4 x 0.05W (17dBm)
FCC ID	TA8AKRC161887-1
INDUSTRY CANADA ID	
TECHNICAL DESCRIPTION (a brief description of the intended use and operation)	LPRU 4410 B5B13 (KRC 161 887/1) is a Remote Radio Unit forming part of the Ericsson Radio Base Station (RBS) equipment. The LPRU provides radio access for mobile and fixed devices and is intended for the indoor environment. The radio operates over 8 Transmit ports in MRO (LTE, NBloT, and NR);Single, and Multi-Carrier transmission with a maximum rated RF Output of 0.05W per port over an operational temperature of 0°C to +50°C. The unit is designed to be rack mounted. .

Signature:

.....

Denis Lalonde

Date: 16 April 2020

Declaration of Build Status Serial Number: TD3F057135

No responsibility will be accepted by TÜV SÜD as to the accuracy of the information declared in this document by the manufacturer.

1.5 PRODUCT INFORMATION

1.5.1 Technical Description

The Equipment Under Test (EUT) LPRU 4410 B5 B13 is an Ericsson AB Radio Unit working in the public mobile service (700 and 850 MHz) bands which provides communication connections to (700 and 850 MHz) network. The LPRU 4410 B5 B13 operates from a -48V DC supply.

The Equipment Under Test (EUT) is shown in the photograph below. A full technical description can be found in the Manufacturer's documentation.

Equipment Under Test



1.6 TEST SETUP

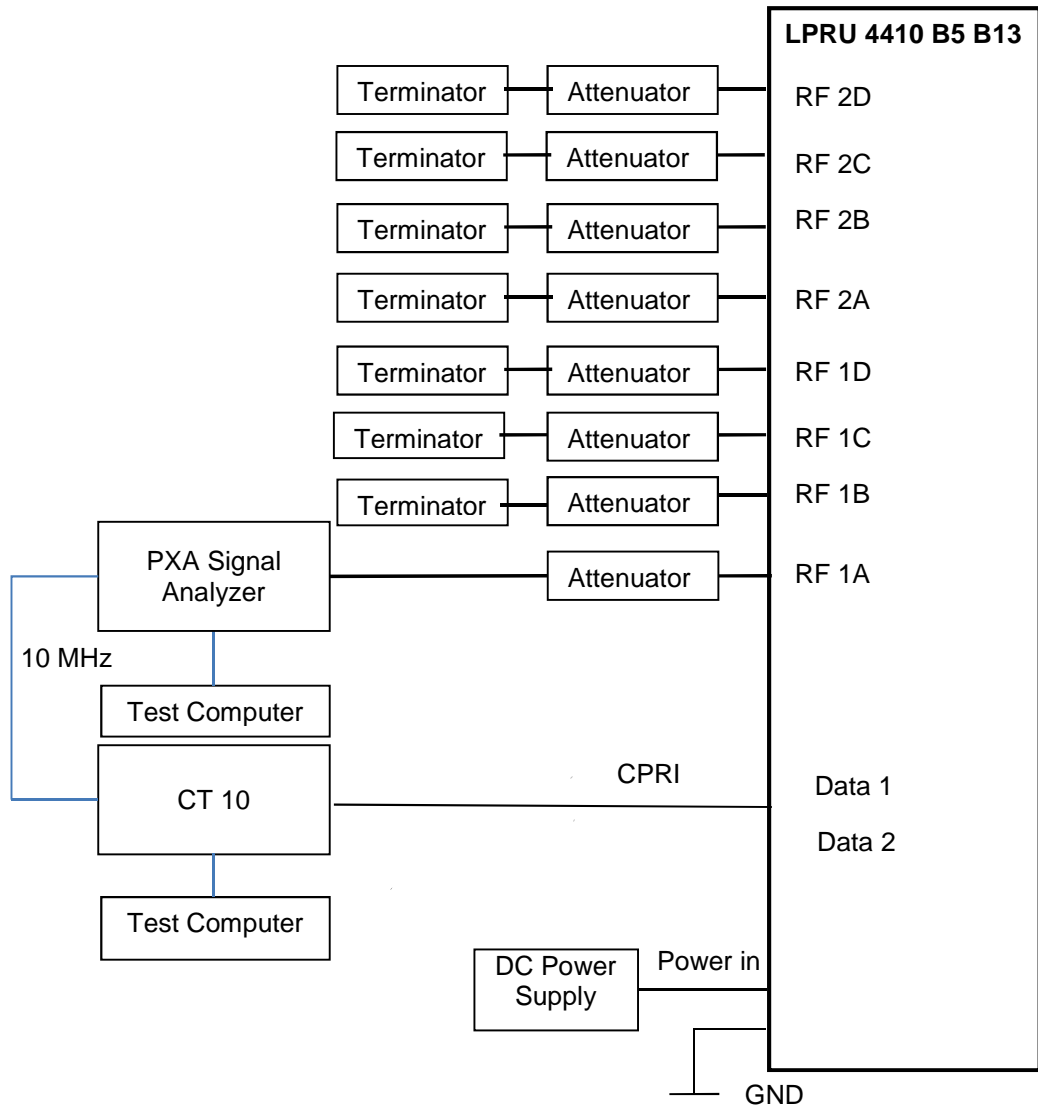



1.7 TEST CONDITIONS

For all tests the EUT was set up in accordance with the relevant test standard and to represent typical operating conditions. Tests were applied with the EUT situated as described in the Test Method for each Test.

The EUT was powered from a -48V DC supply.

FCC Measurement Facility Registration Number: CA4810

1.8 DEVIATION FROM THE STANDARD

No deviations from the applicable test standards or test plan were made during testing.

1.9 MODIFICATION RECORD

Band 5 BOM Changes					
Ref Des	Old EPN	Description	New EPN	Description	
L13A7	REG 724 5181/91PH	INDUCTOR/9.1nH 3% 0201	REG 724 5181/75PH	7.5nH 3% 0201	
L14A7	REG 724 5181/91PH	INDUCTOR/9.1nH 3% 0201	REG 724 5181/75PH	7.5nH 3% 0201	

Band 13 BOM Changes					
Ref Des	Old EPN	Description	New EPN	Description	
R102A8	DNI	NA	RJC 545 1111/18C	1.8pF +/-0.25pF 0201 100V HQ C0G	
R103A8	DNI	NA	RJC 545 1111/18C	1.8pF +/-0.25pF 0201 100V HQ C0G	
R119A10	REP 621 105/51	RESISTOR/51Kohm 1% 0201 0.05W	REP 621 104/1	1kohm 1% 0201 0.05W	



Product Service

SECTION 2

TEST DETAILS



2.1 MAXIMUM PEAK OUTPUT POWER AND PEAK TO AVERAGE RATIO – CONDUCTED

2.1.1 Specification Reference

FCC CFR 47 Part 22, Clause 22.913 (a)
 FCC CFR 47 Part 27, Clause 27.50
 FCC CFR 47 Part 2, Clause 2.1046

2.1.2 Date of Test and Modification State

04, 06 February and 01 April 2020, - Modification State 0

2.1.3 Test Equipment Used

The major items of test equipment used for the above tests are identified in Section 3.1.

2.1.4 Environmental Conditions

Ambient Temperature 23.5 – 26.3°C
 Relative Humidity 31.3 - 36.9%

2.1.5 Test Method

All measurements were made in accordance with FCC KDB 971168 D01, clause 5.2.1 and summed in accordance with FCC KDB 662911 D01.

2.1.6 Test Results

FCC Part 22

Configuration A

Maximum Output Power 17 dBm per port

Antenna	LTE Modulation	LTE Carrier Bandwidth	Peak to Average Ratio (PAR) / Output Power		
			Channel Position B		
			PAR (dB)	Average Power	
dBm	dBm/MHz				
A	QPSK	5.0 MHz	8.07	16.38	10.61
B	QPSK	5.0 MHz	8.01	16.54	10.84
C	QPSK	5.0 MHz	8.10	15.86	10.12
D	QPSK	5.0 MHz	8.07	16.09	10.34
Total			-	22.25	16.51
A	QPSK	10.0 MHz	8.35	15.86	6.95
B	QPSK	10.0 MHz	8.26	16.22	7.52
C	QPSK	10.0 MHz	8.35	15.50	6.94
D	QPSK	10.0 MHz	8.29	16.00	7.12
Total			-	21.92	13.16



Product Service

Antenna A - LTE Modulation QPSK - LTE Carrier Bandwidth 5.0 MHz - Channel Position B

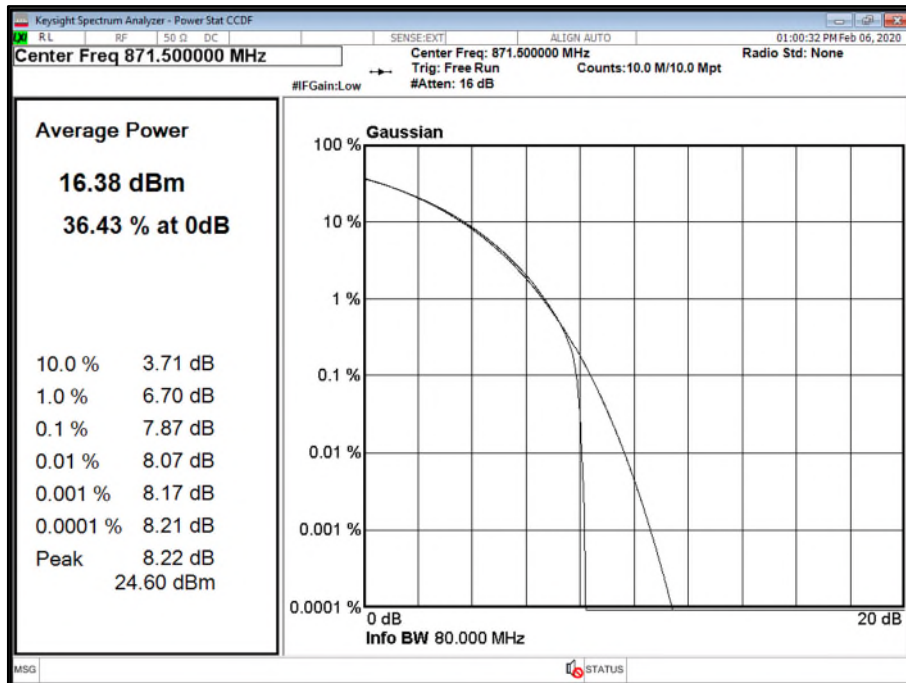

Antenna B - LTE Modulation QPSK - LTE Carrier Bandwidth 5.0 MHz - Channel Position B

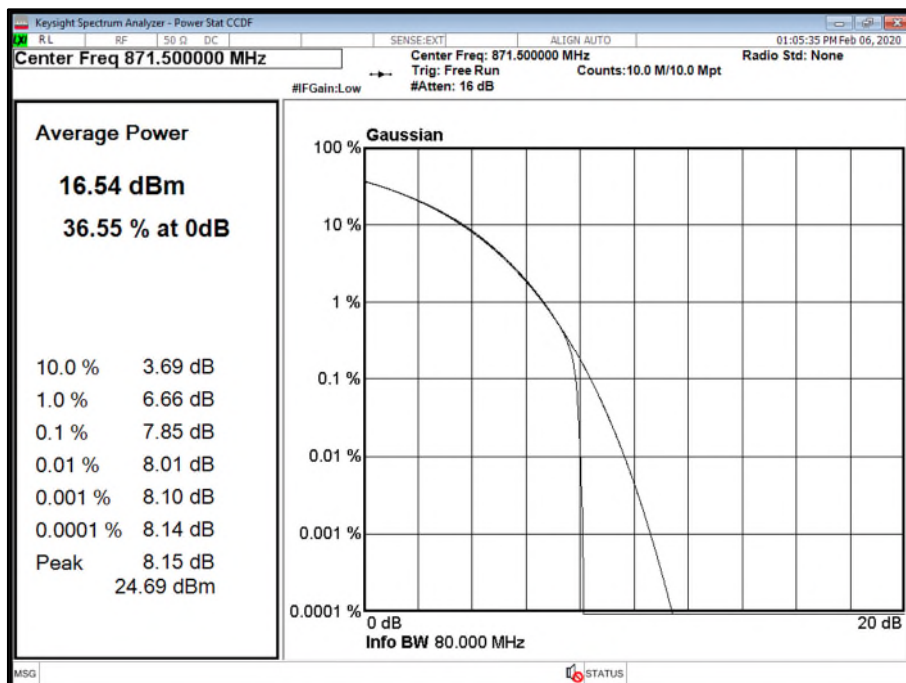

Antenna C - LTE Modulation QPSK - LTE Carrier Bandwidth 5.0 MHz - Channel Position B

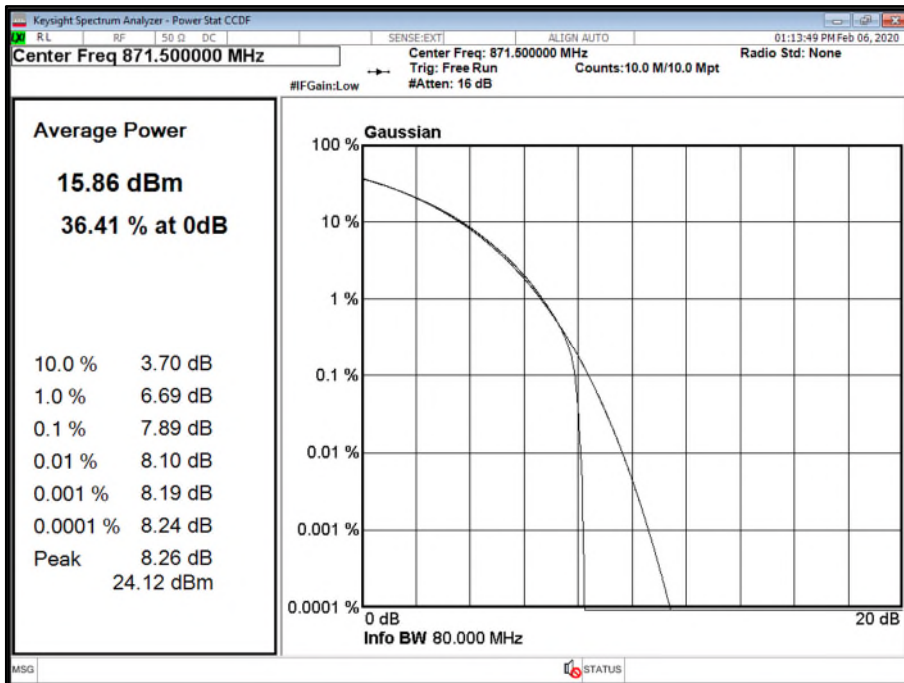

Antenna D - LTE Modulation QPSK - LTE Carrier Bandwidth 5.0 MHz - Channel Position B

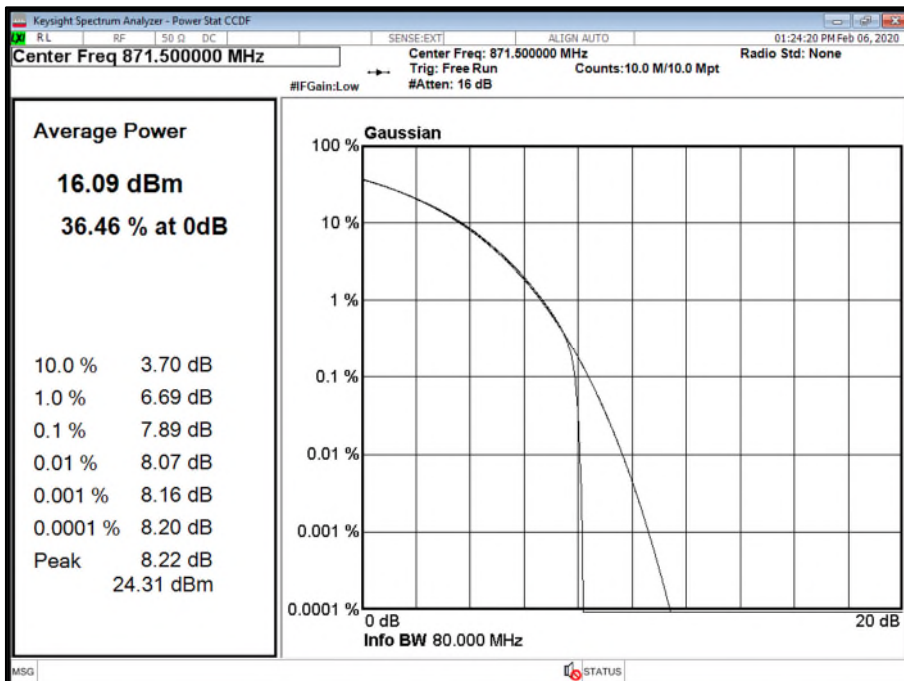



Product Service

Antenna A - LTE Modulation QPSK - LTE Carrier Bandwidth 10.0 MHz - Channel Position B

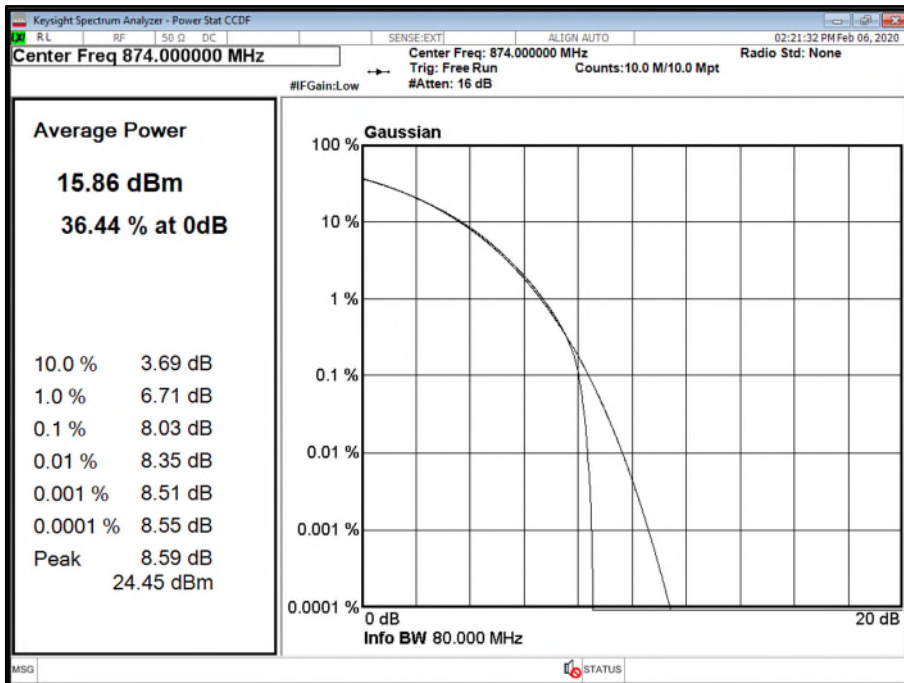

Antenna B - LTE Modulation QPSK - LTE Carrier Bandwidth 10.0 MHz - Channel Position B

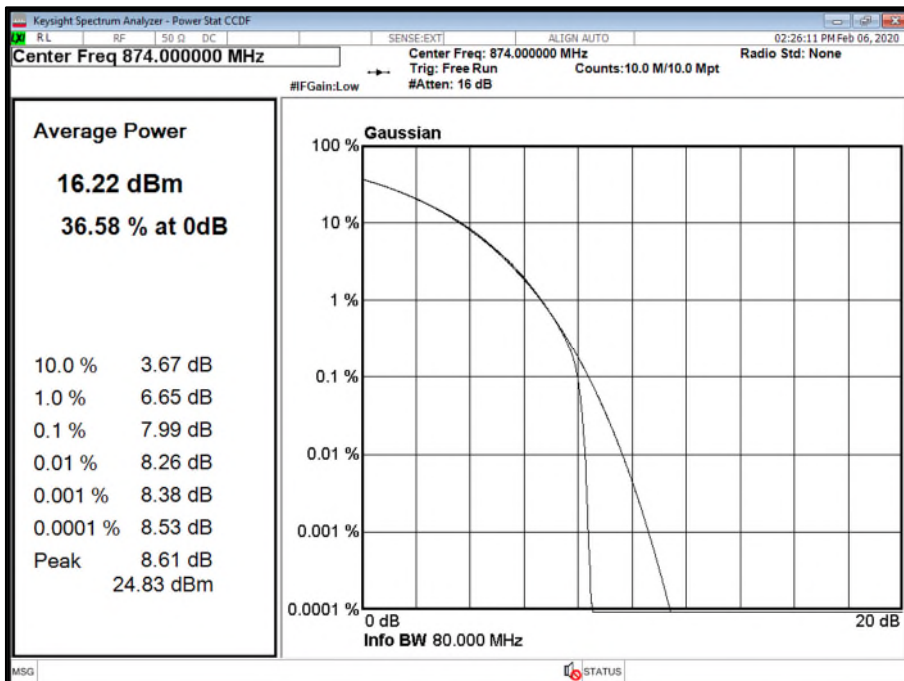

Antenna C - LTE Modulation QPSK - LTE Carrier Bandwidth 10.0 MHz - Channel Position B

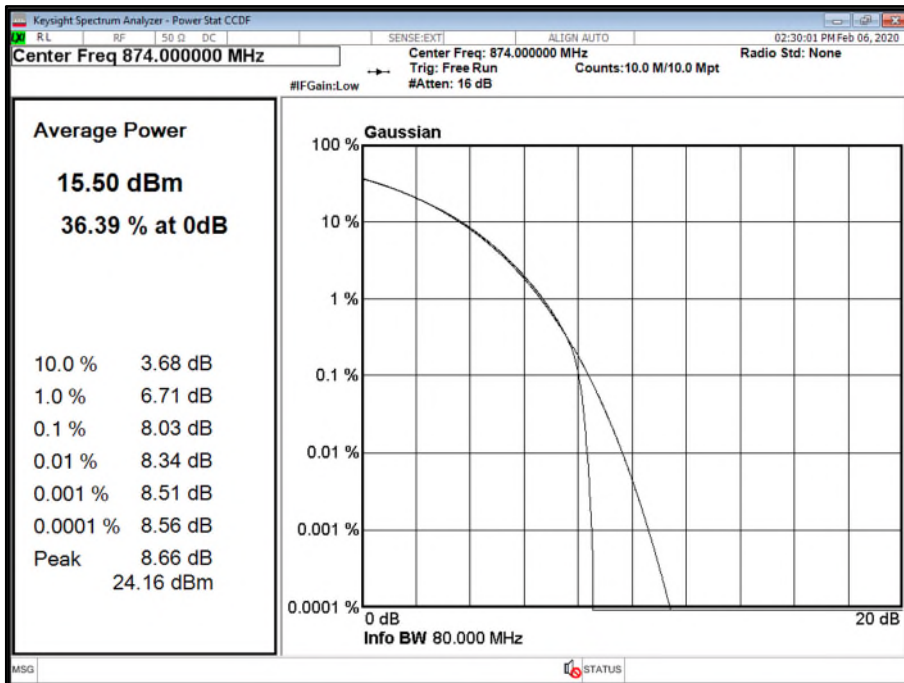

Antenna D - LTE Modulation QPSK - LTE Carrier Bandwidth 10.0 MHz - Channel Position B

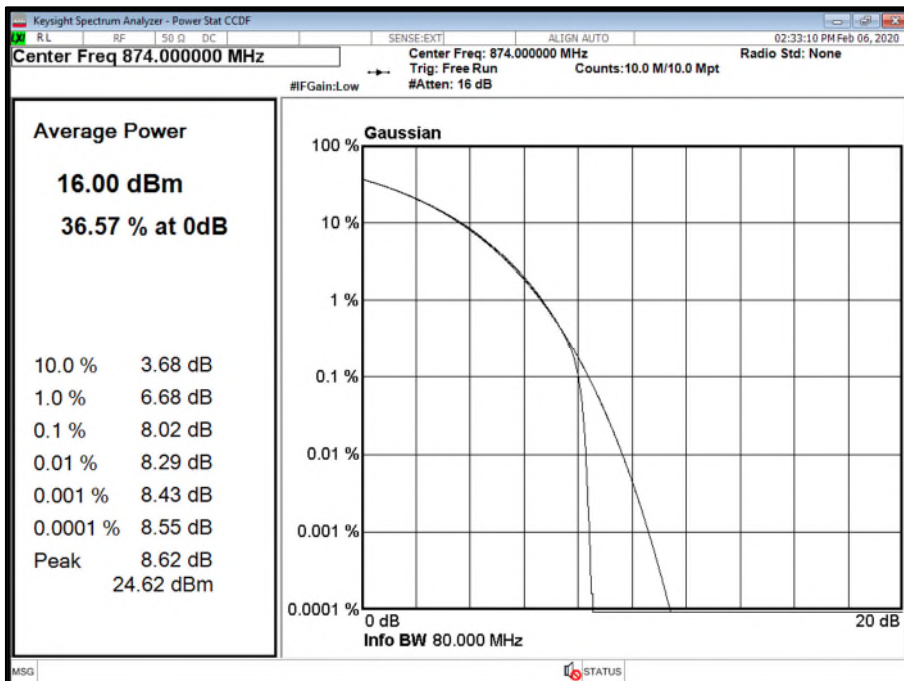



Product Service

Antenna A - LTE Modulation QPSK - LTE Carrier Bandwidth 5.0 MHz - Channel Position B

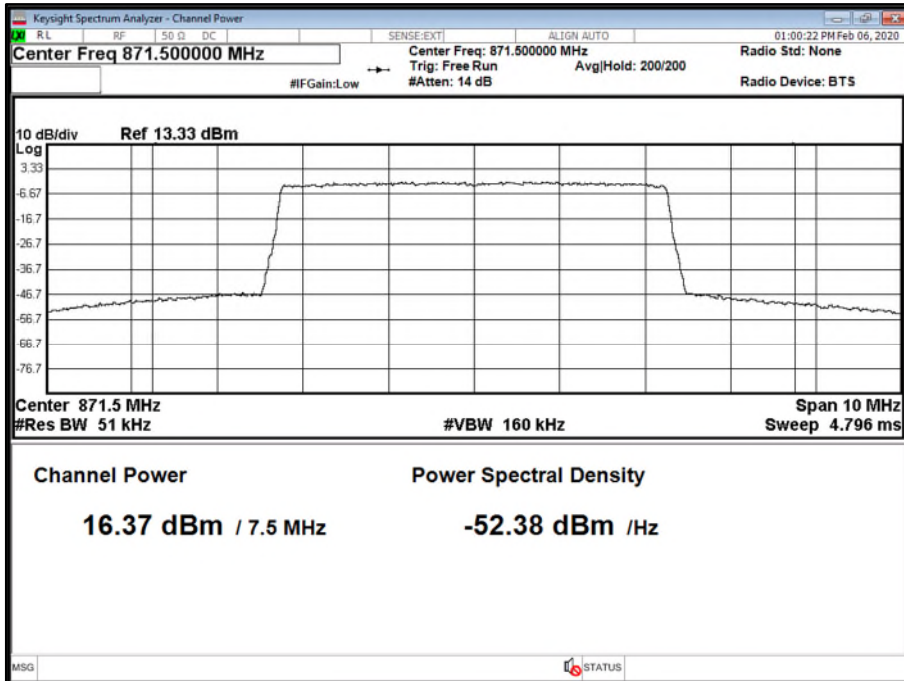

Antenna B - LTE Modulation QPSK - LTE Carrier Bandwidth 5.0 MHz - Channel Position B

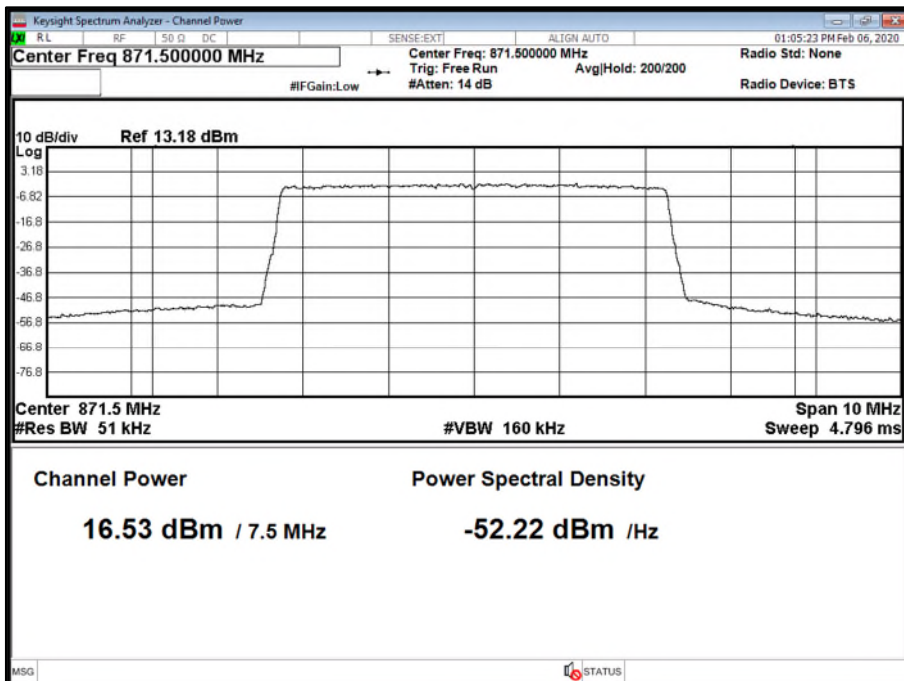



Product Service

Antenna C - LTE Modulation QPSK - LTE Carrier Bandwidth 5.0 MHz - Channel Position B

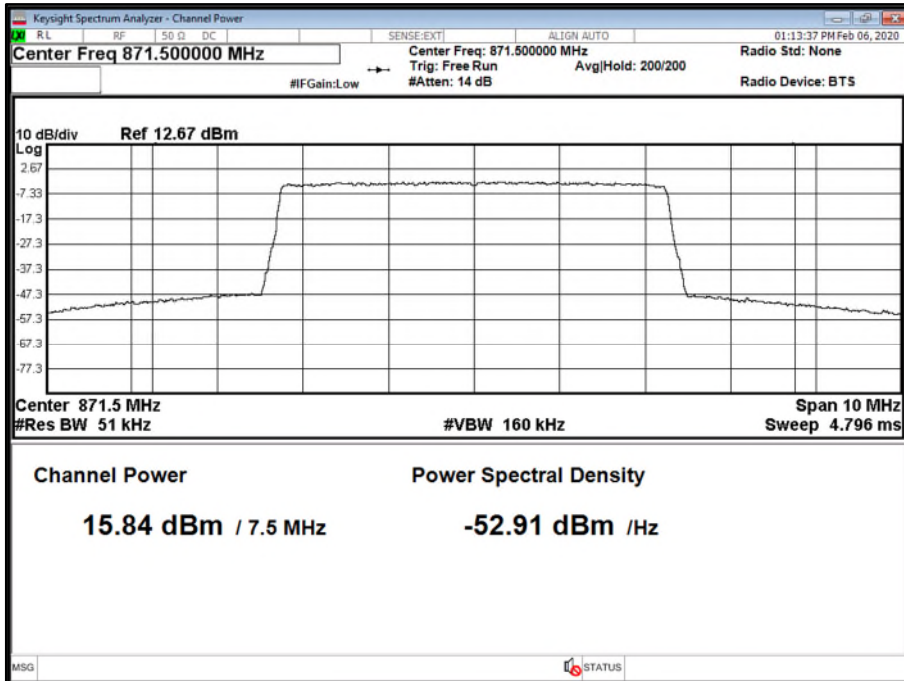

Antenna D - LTE Modulation QPSK - LTE Carrier Bandwidth 5.0 MHz - Channel Position B

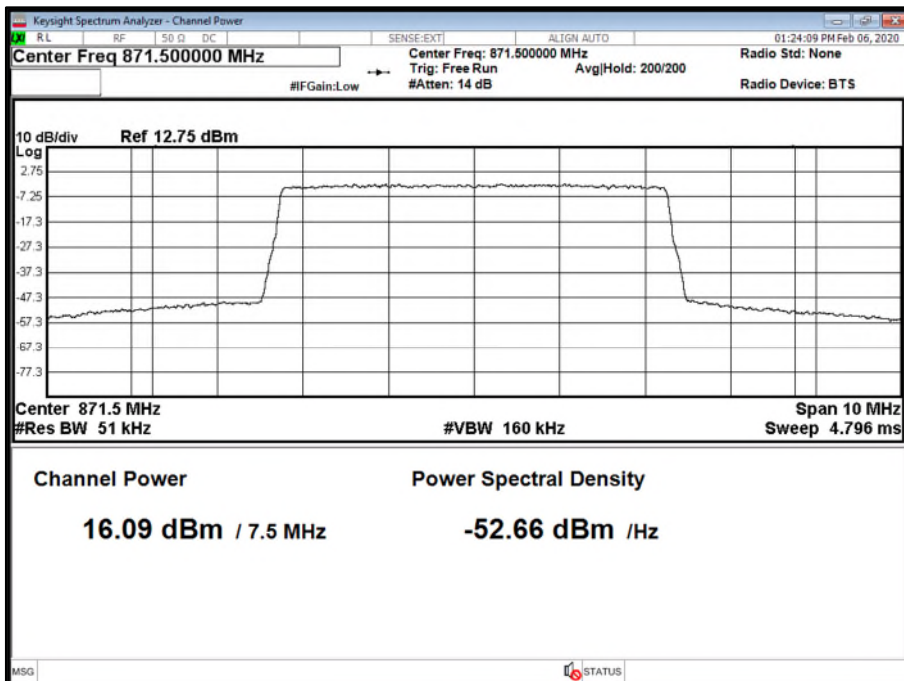



Product Service

Antenna A - LTE Modulation QPSK - LTE Carrier Bandwidth 10.0 MHz - Channel Position B

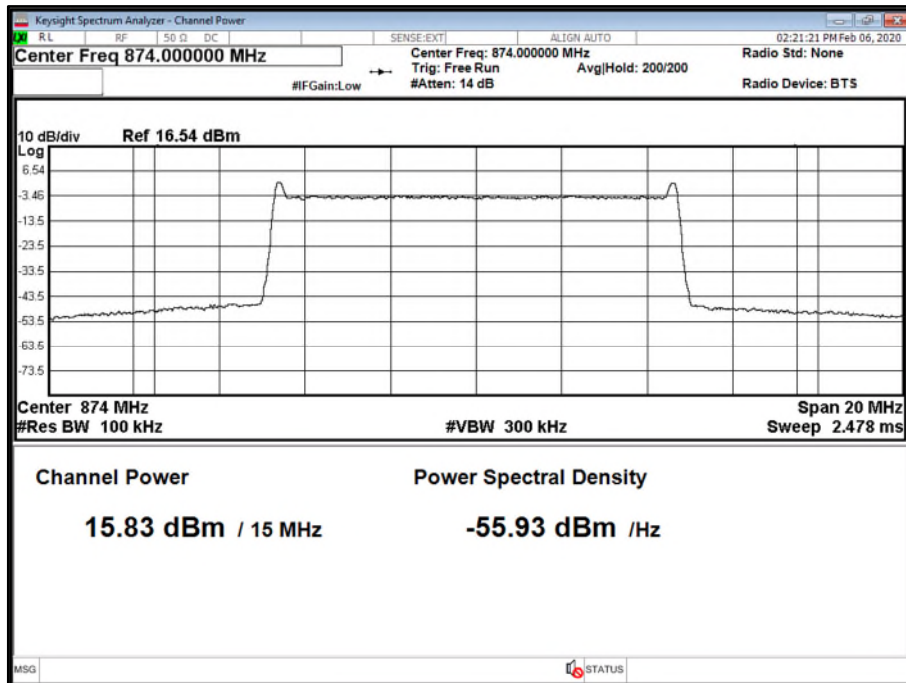

Antenna B - LTE Modulation QPSK - LTE Carrier Bandwidth 10.0 MHz - Channel Position B

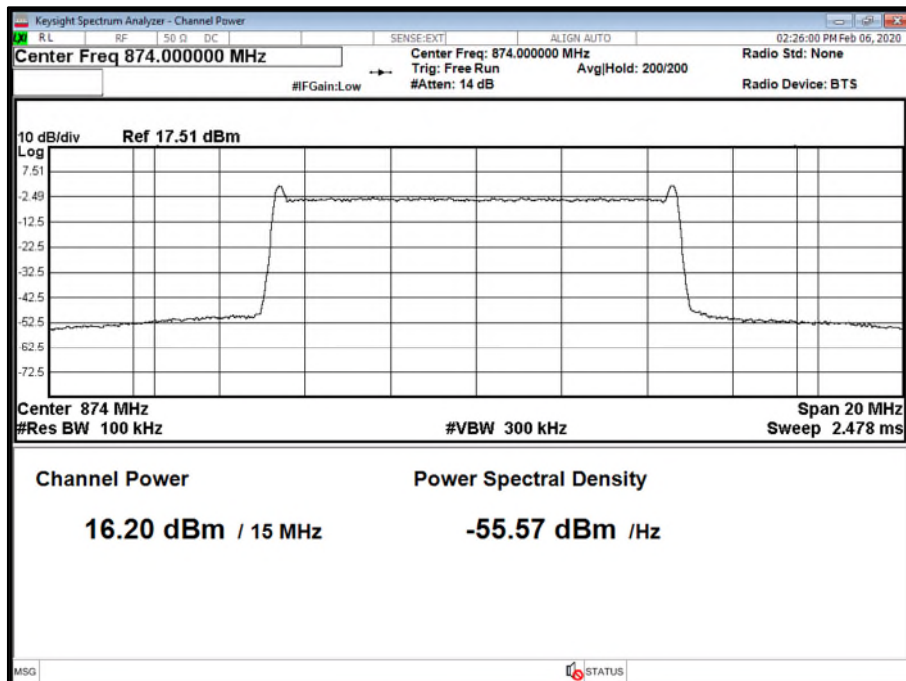



Product Service

Antenna C - LTE Modulation QPSK - LTE Carrier Bandwidth 10.0 MHz - Channel Position B

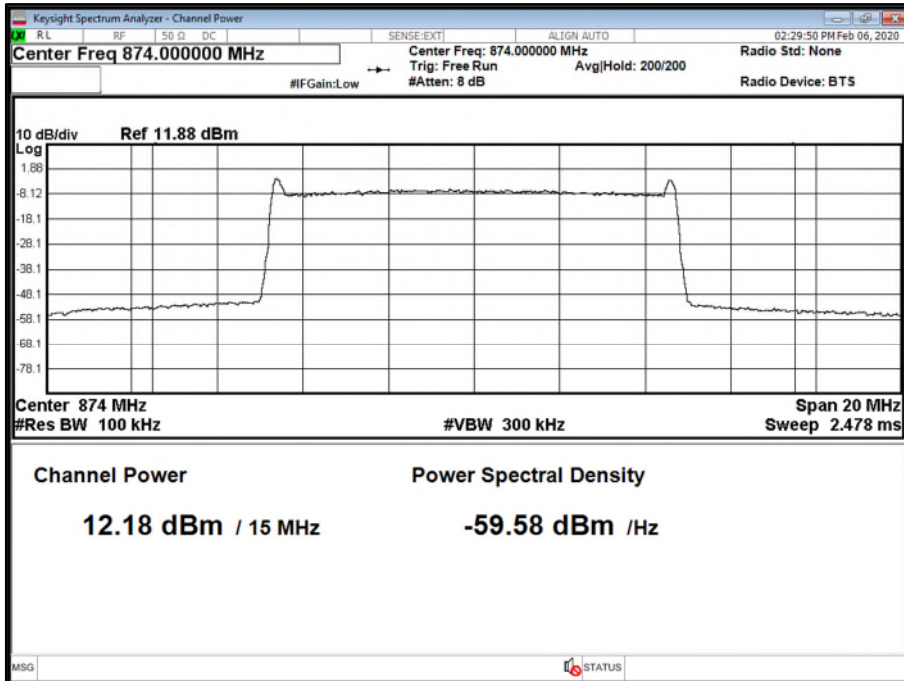

Antenna D - LTE Modulation QPSK - LTE Carrier Bandwidth 10.0 MHz - Channel Position B

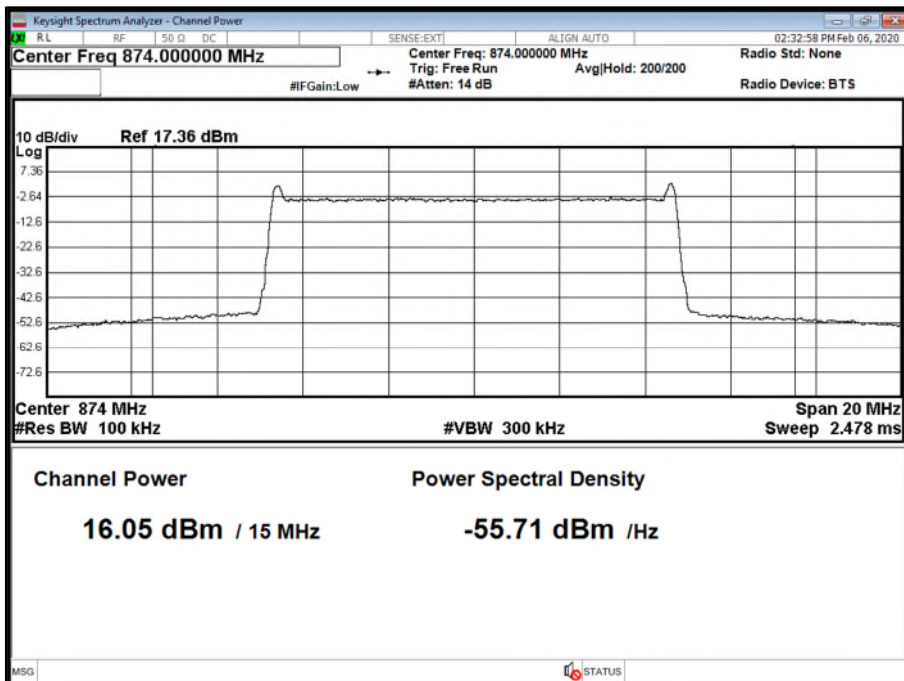



Product Service

Configuration A

Maximum Output Power 17 dBm per port

Antenna	LTE Modulation	LTE Carrier Bandwidth	Peak to Average Ratio (PAR) / Output Power		
			Channel Position M		
			PAR (dB)	Average Power	
dBm	dBm/MHz				
A	QPSK	5.0 MHz	8.09	16.46	10.71
B	QPSK	5.0 MHz	8.02	16.26	10.51
C	QPSK	5.0 MHz	8.09	16.46	10.64
D	QPSK	5.0 MHz	8.10	15.63	9.97
Total			-	22.24	16.49
A	QPSK	10.0 MHz	8.24	15.82	7.21
B	QPSK	10.0 MHz	8.19	16.33	7.62
C	QPSK	10.0 MHz	8.24	15.83	7.38
D	QPSK	10.0 MHz	8.25	16.08	7.25
Total			-	22.04	13.39

Antenna A - LTE Modulation QPSK - LTE Carrier Bandwidth 5.0 MHz - Channel Position M

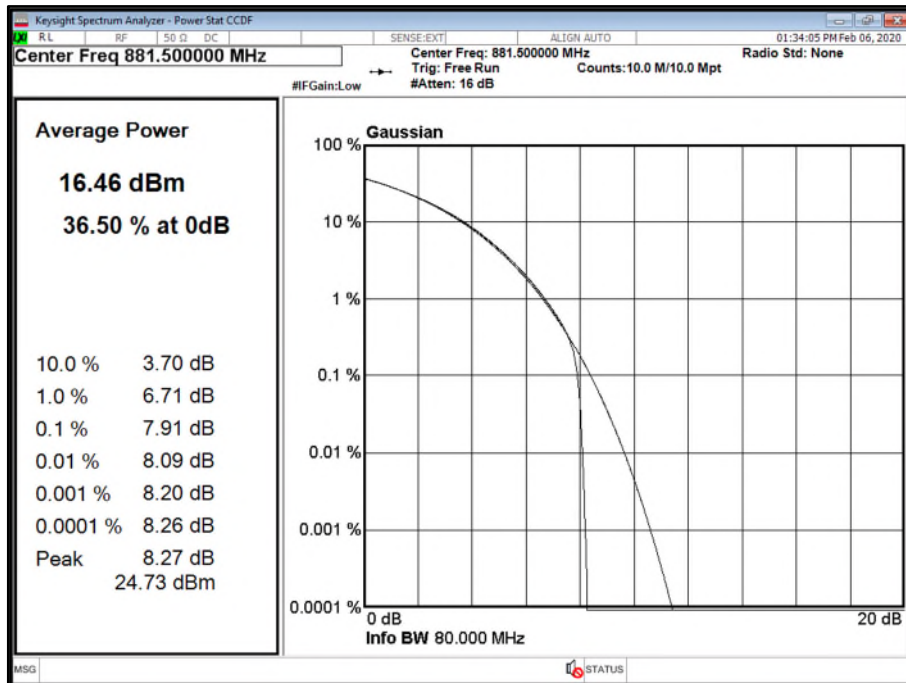

Antenna B - LTE Modulation QPSK - LTE Carrier Bandwidth 5.0 MHz - Channel Position M

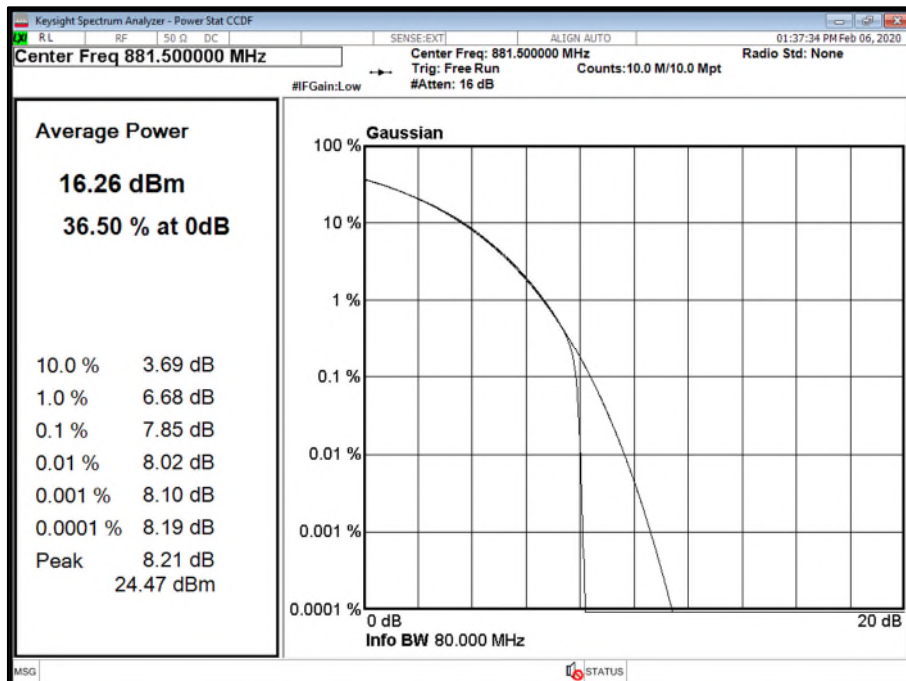



Product Service

Antenna C - LTE Modulation QPSK - LTE Carrier Bandwidth 5.0 MHz - Channel Position M

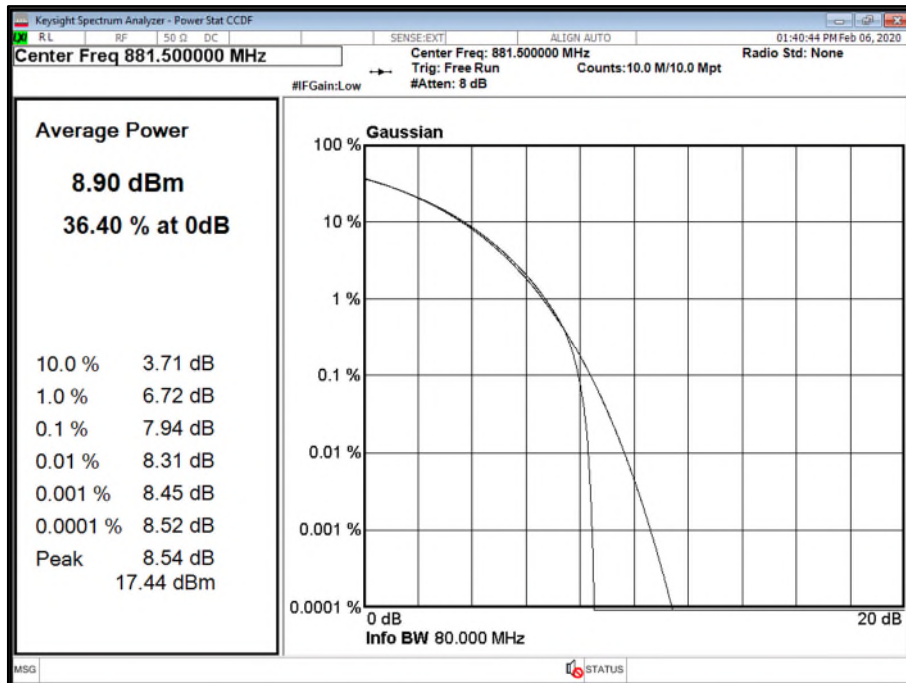

Antenna D - LTE Modulation QPSK - LTE Carrier Bandwidth 5.0 MHz - Channel Position M

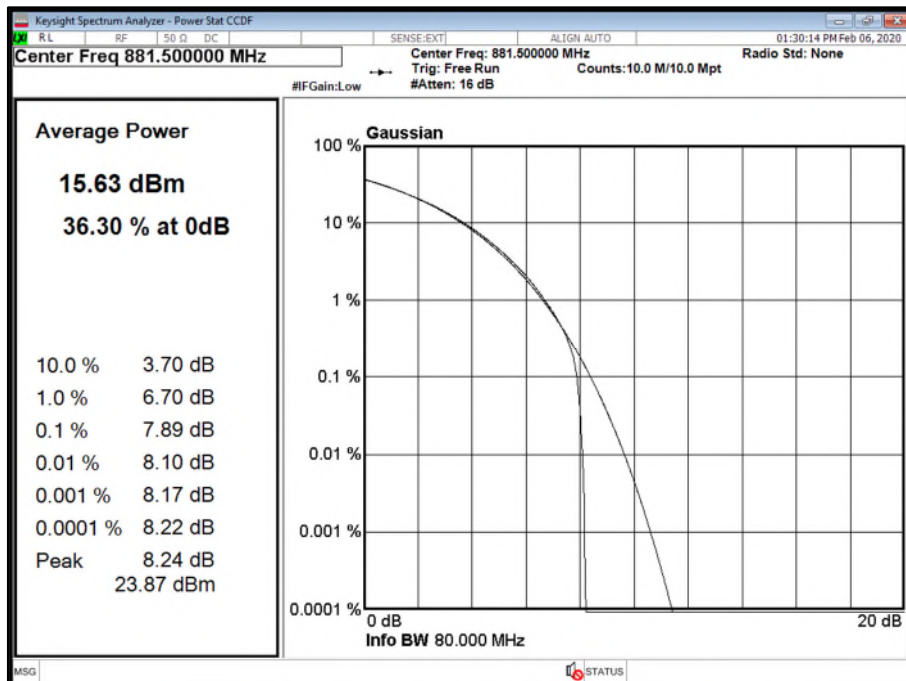



Product Service

Antenna A - LTE Modulation QPSK - LTE Carrier Bandwidth 10.0 MHz - Channel Position M

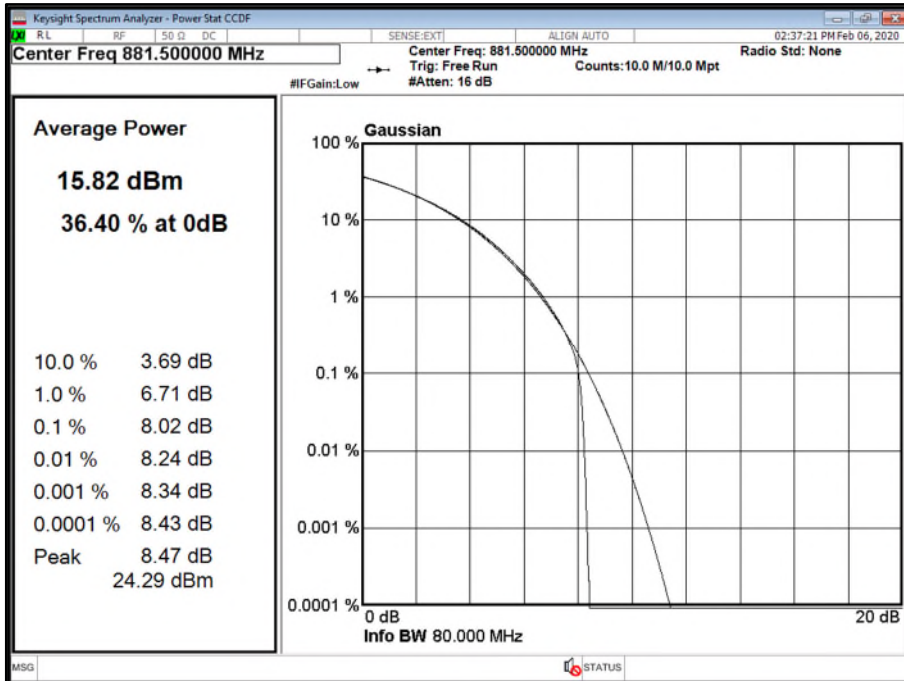

Antenna B - LTE Modulation QPSK - LTE Carrier Bandwidth 10.0 MHz - Channel Position M

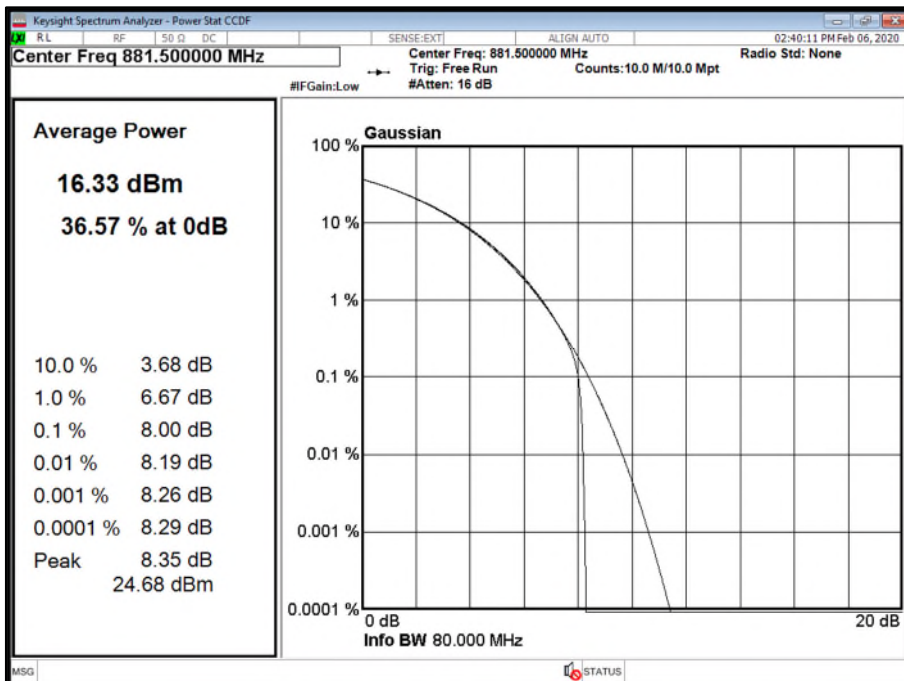

Antenna C - LTE Modulation QPSK - LTE Carrier Bandwidth 10.0 MHz - Channel Position M

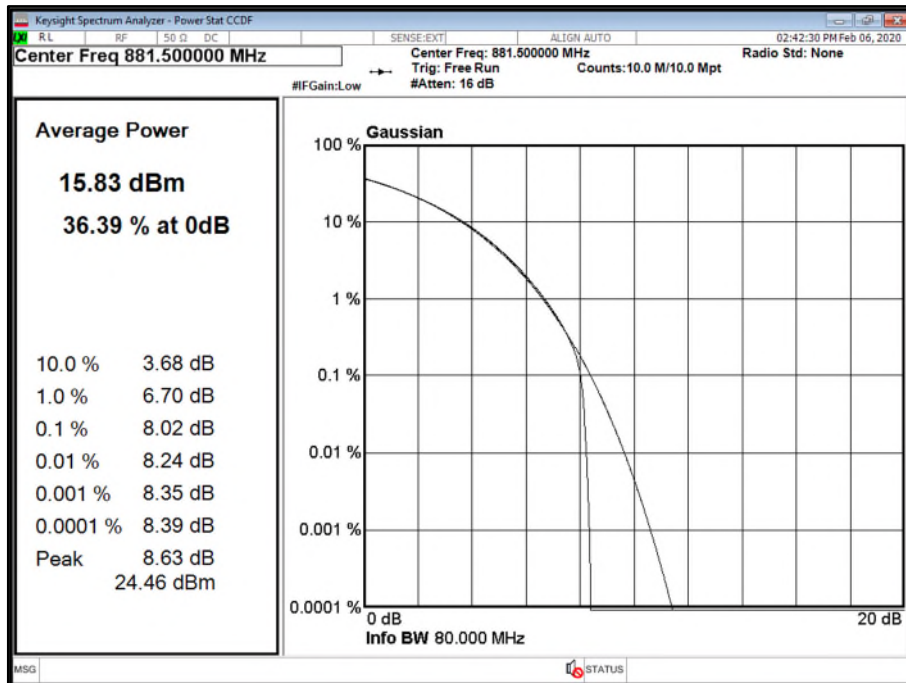

Antenna D - LTE Modulation QPSK - LTE Carrier Bandwidth 10.0 MHz - Channel Position M

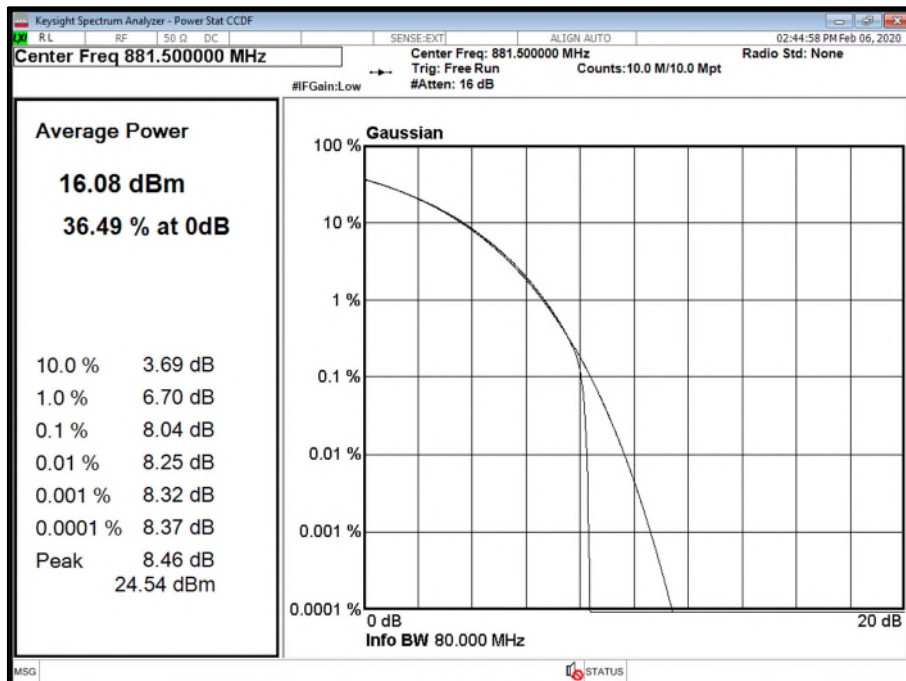



Product Service

Antenna A - LTE Modulation QPSK - LTE Carrier Bandwidth 5.0 MHz - Channel Position M

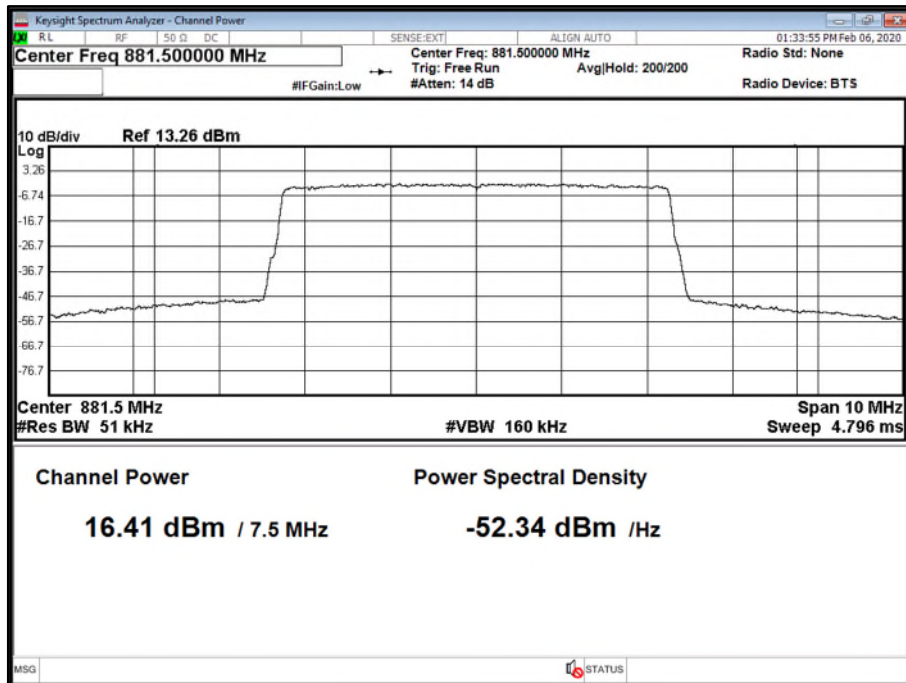

Antenna B - LTE Modulation QPSK - LTE Carrier Bandwidth 5.0 MHz - Channel Position M

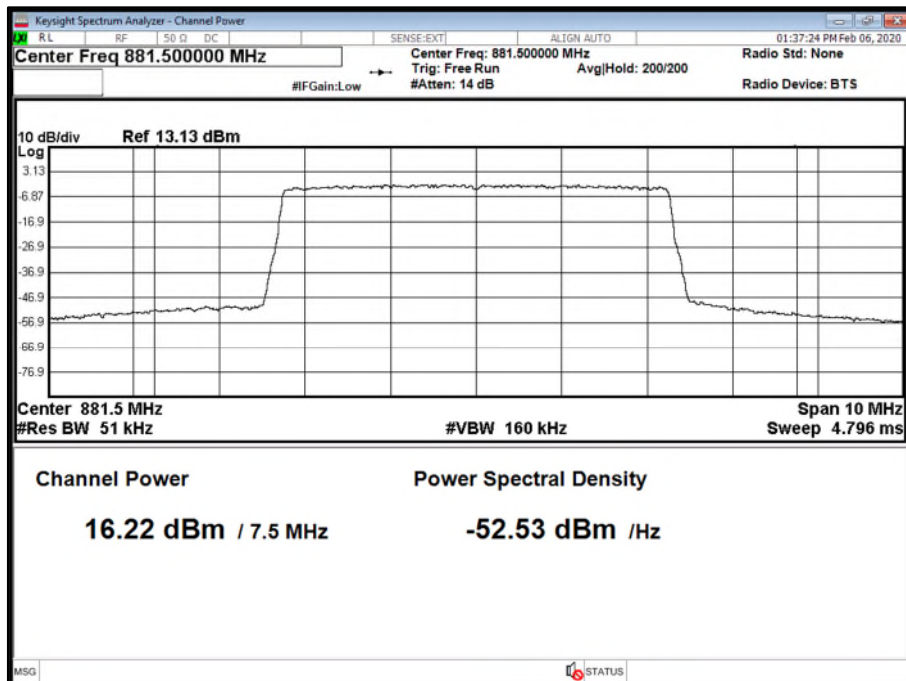



Product Service

Antenna C - LTE Modulation QPSK - LTE Carrier Bandwidth 5.0 MHz - Channel Position M

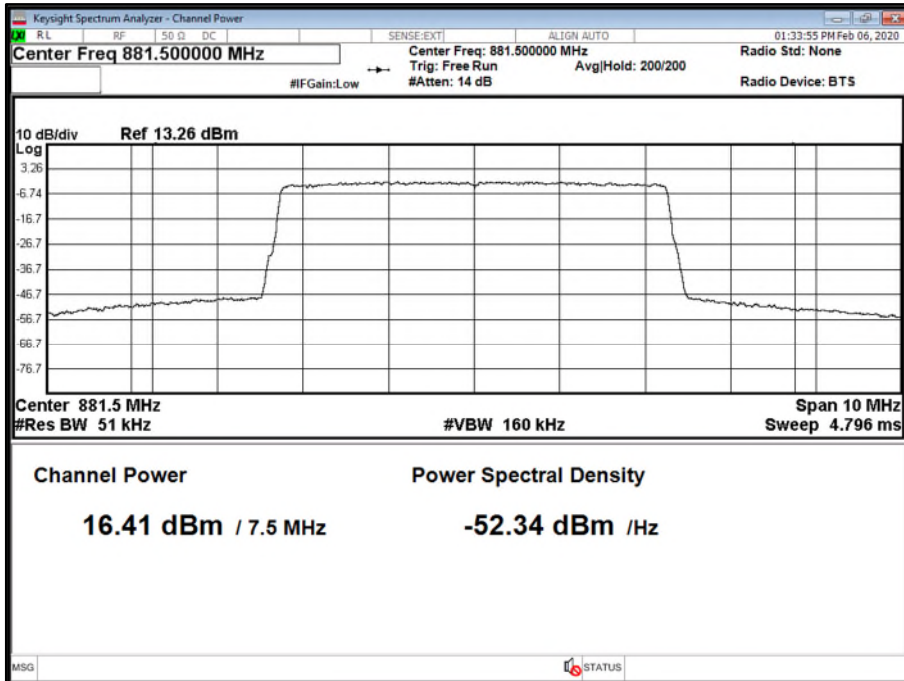

Antenna D - LTE Modulation QPSK - LTE Carrier Bandwidth 5.0 MHz - Channel Position M

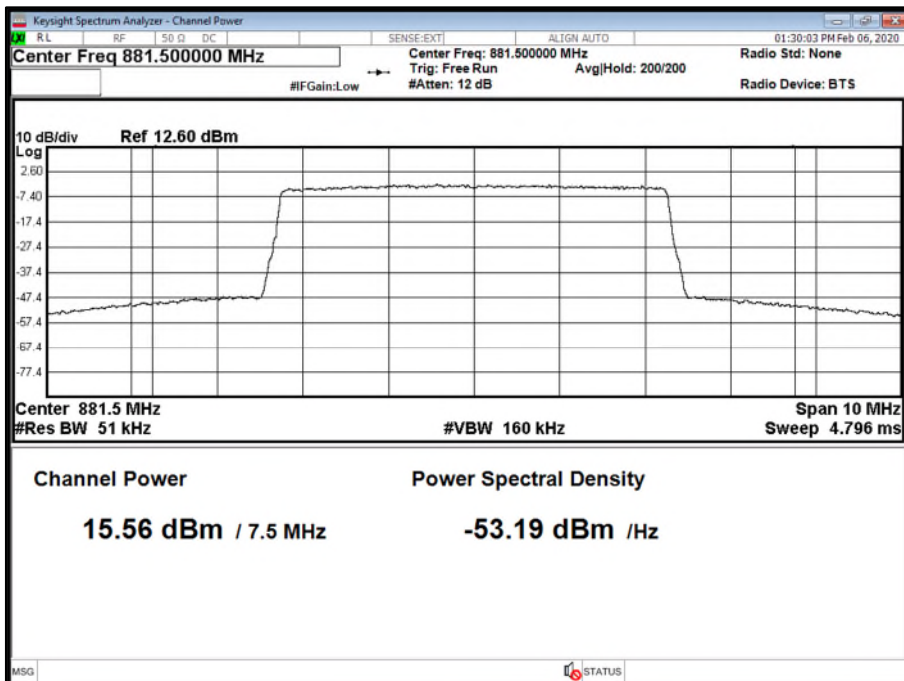



Product Service

Antenna A - LTE Modulation QPSK - LTE Carrier Bandwidth 10.0 MHz - Channel Position M

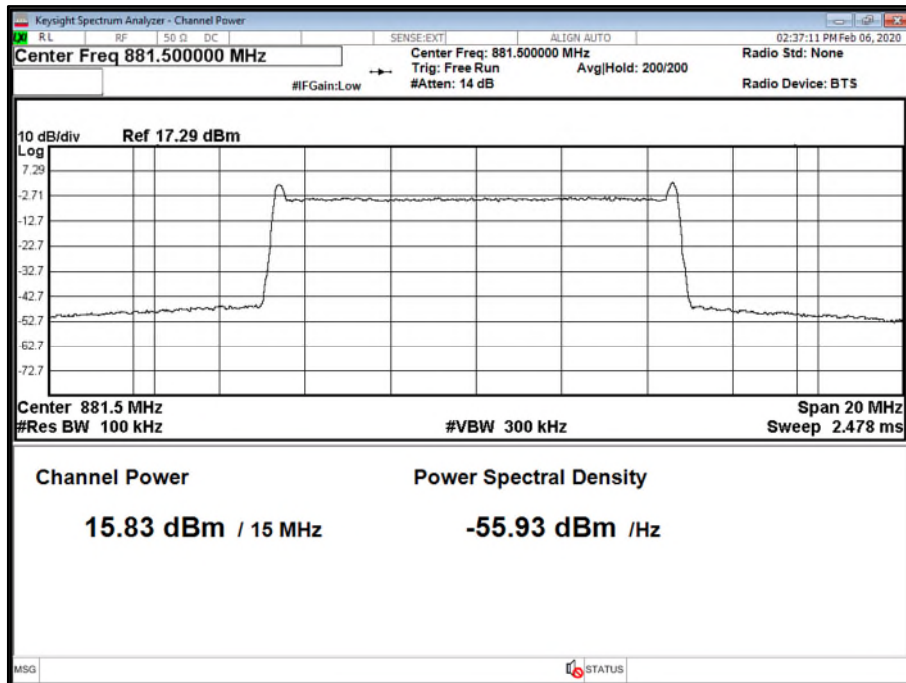

Antenna B - LTE Modulation QPSK - LTE Carrier Bandwidth 10.0 MHz - Channel Position M

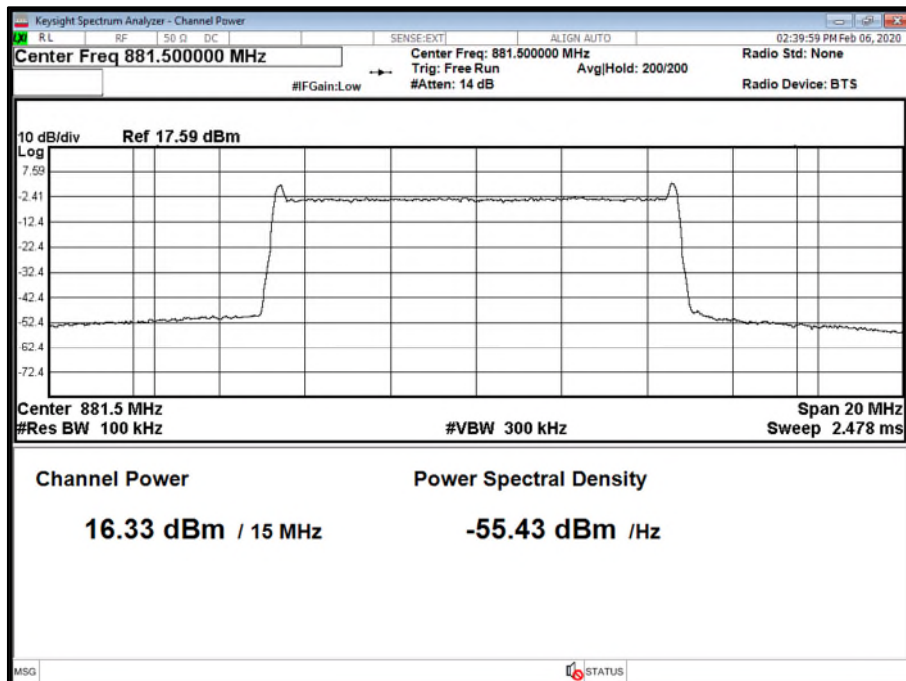



Product Service

Antenna C - LTE Modulation QPSK - LTE Carrier Bandwidth 10.0 MHz - Channel Position M

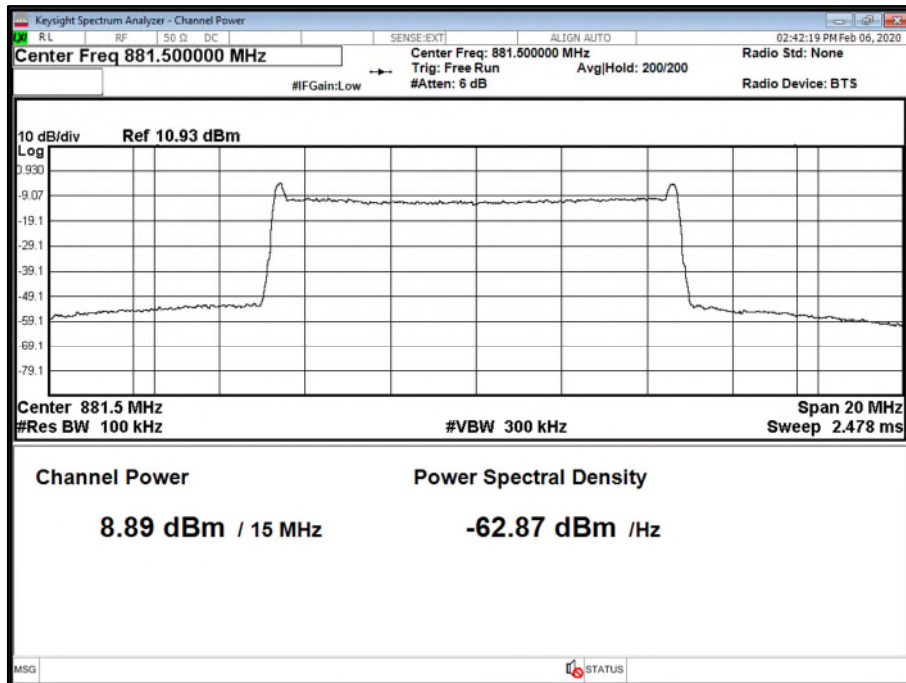

Antenna D - LTE Modulation QPSK - LTE Carrier Bandwidth 10.0 MHz - Channel Position M

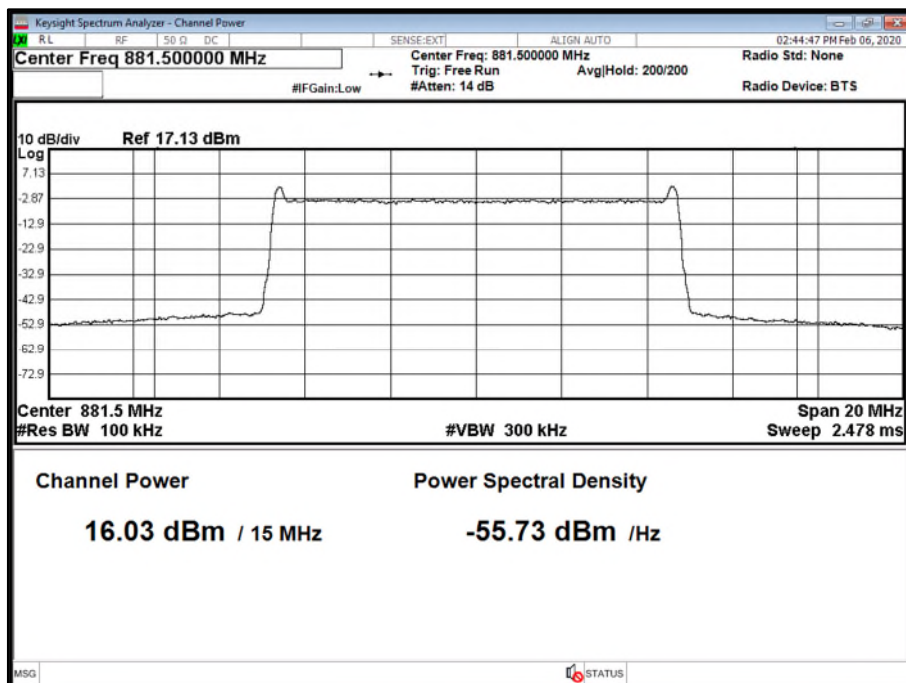

Configuration A

Maximum Output Power 17 dBm per port



Product Service

Antenna	LTE Modulation	LTE Carrier Bandwidth	Peak to Average Ratio (PAR) / Output Power		
			PAR (dB)	Channel Position T	
				Average Power	
				dBm	dBm/MHz
A	QPSK	5.0 MHz	8.07	16.39	10.69
B	QPSK	5.0 MHz	8.03	16.44	10.61
C	QPSK	5.0 MHz	8.09	15.94	10.25
D	QPSK	5.0 MHz	8.12	16.13	10.50
Total			-	22.25	16.54
A	QPSK	10.0 MHz	8.32	15.69	7.28
B	QPSK	10.0 MHz	8.29	16.07	7.45
C	QPSK	10.0 MHz	8.32	15.69	7.28
D	QPSK	10.0 MHz	8.33	16.08	7.35
Total			-	21.91	13.36

Antenna A - LTE Modulation QPSK - LTE Carrier Bandwidth 5.0 MHz - Channel Position T

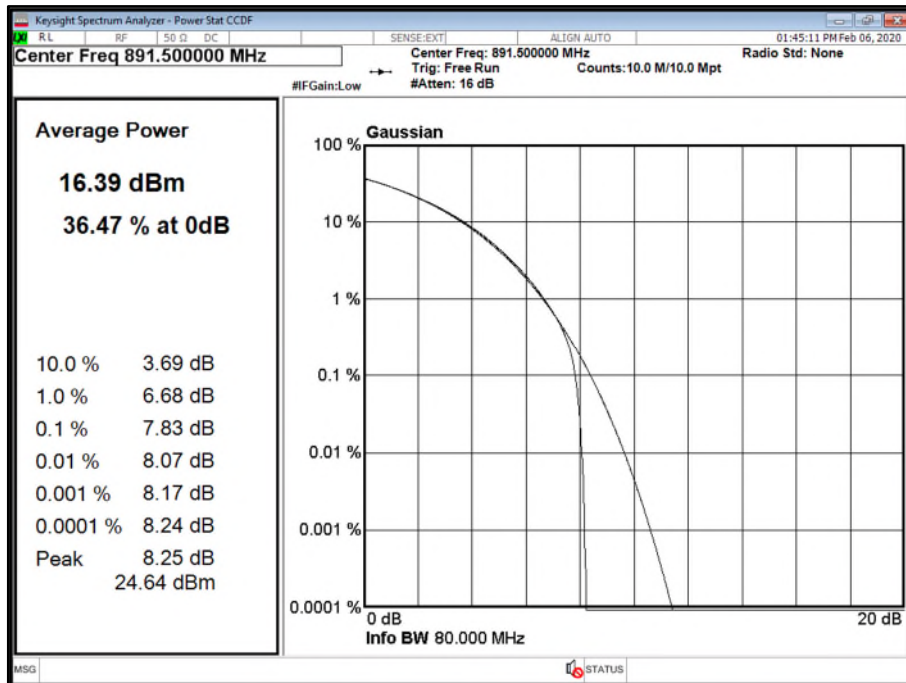

Antenna B - LTE Modulation QPSK - LTE Carrier Bandwidth 5.0 MHz - Channel Position T

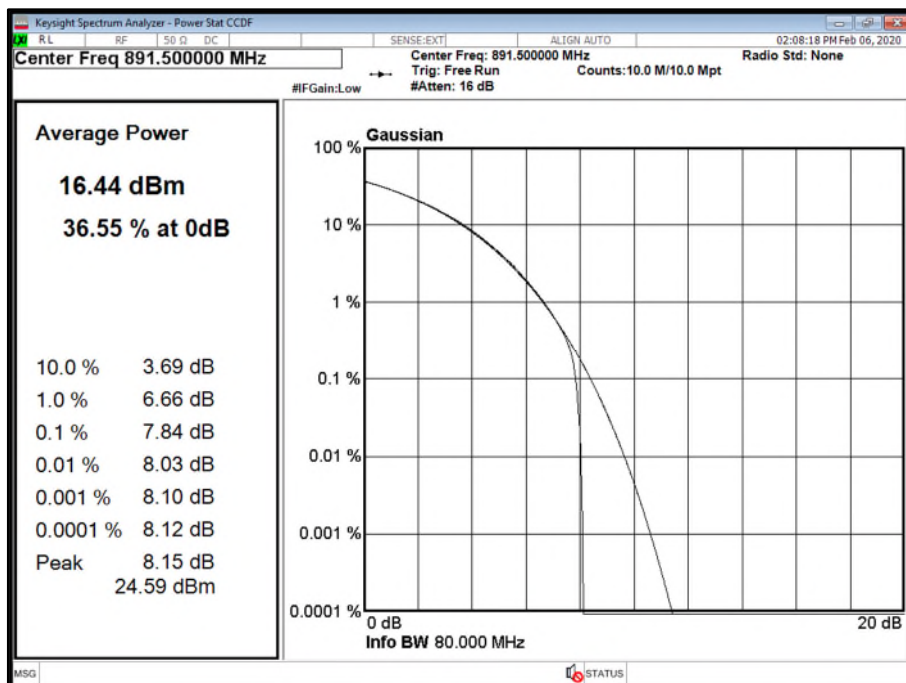

Antenna C - LTE Modulation QPSK - LTE Carrier Bandwidth 5.0 MHz - Channel Position T

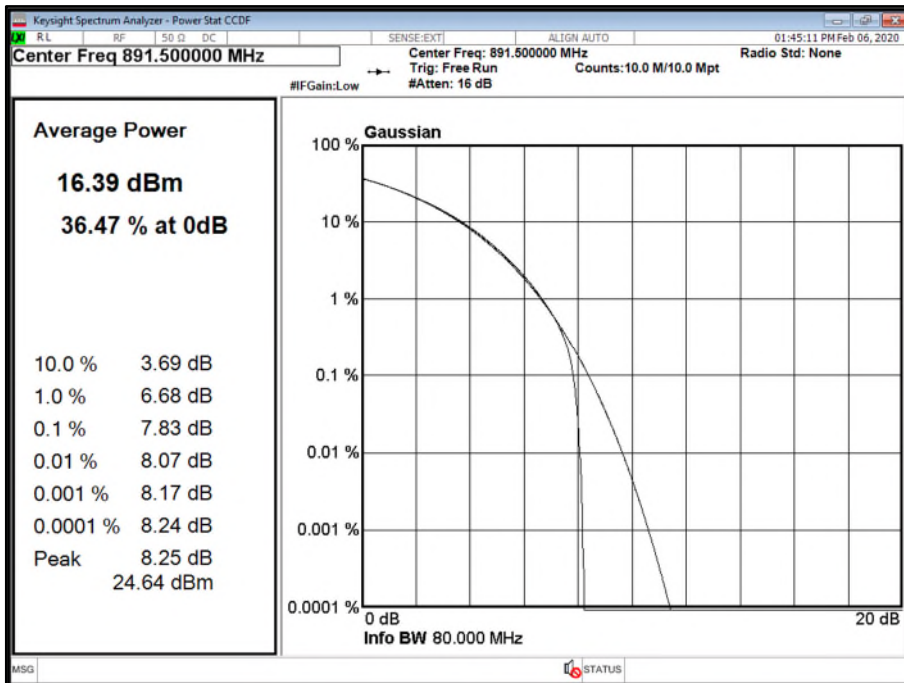

Antenna D - LTE Modulation QPSK - LTE Carrier Bandwidth 5.0 MHz - Channel Position T

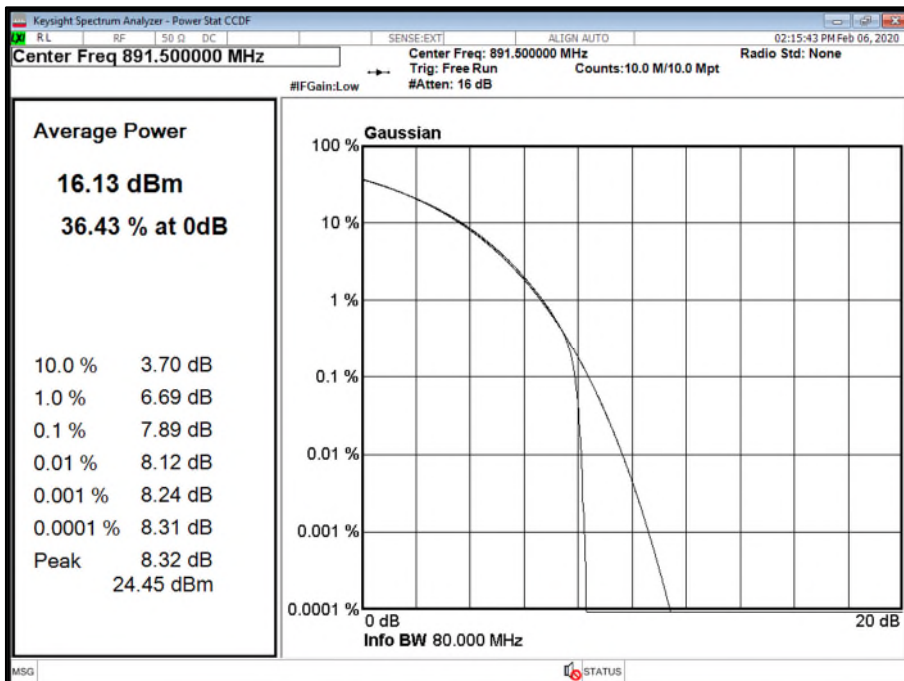



Product Service

Antenna A - LTE Modulation QPSK - LTE Carrier Bandwidth 10.0 MHz - Channel Position T

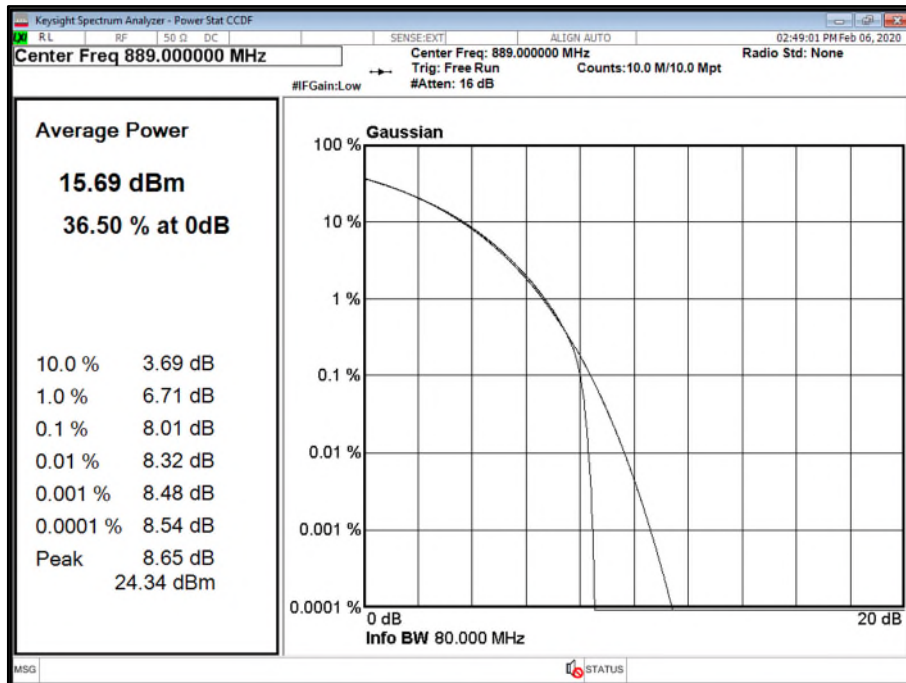

Antenna B - LTE Modulation QPSK - LTE Carrier Bandwidth 10.0 MHz - Channel Position T

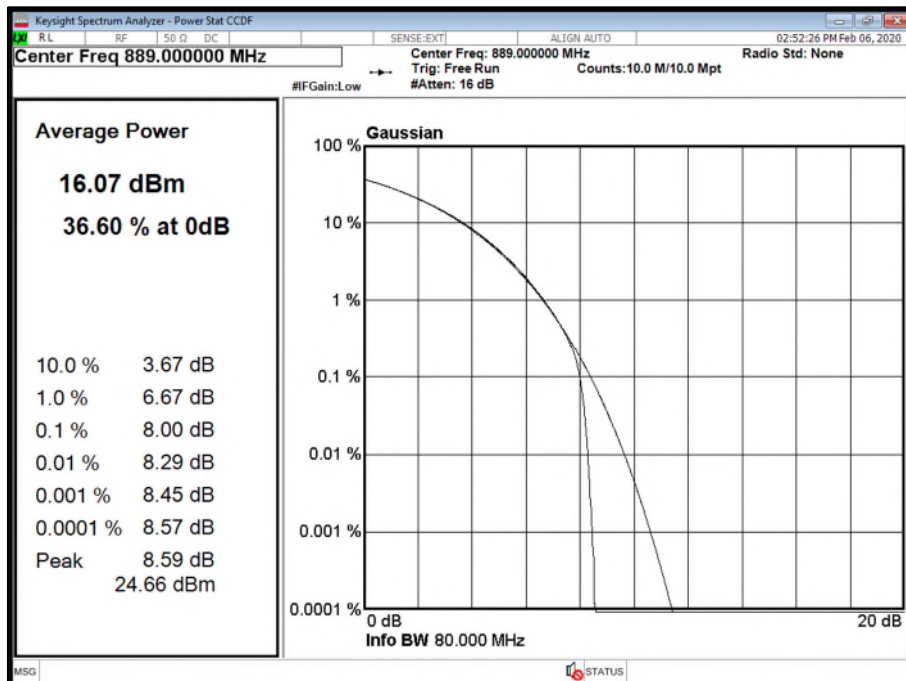

Antenna C - LTE Modulation QPSK - LTE Carrier Bandwidth 10.0 MHz - Channel Position T

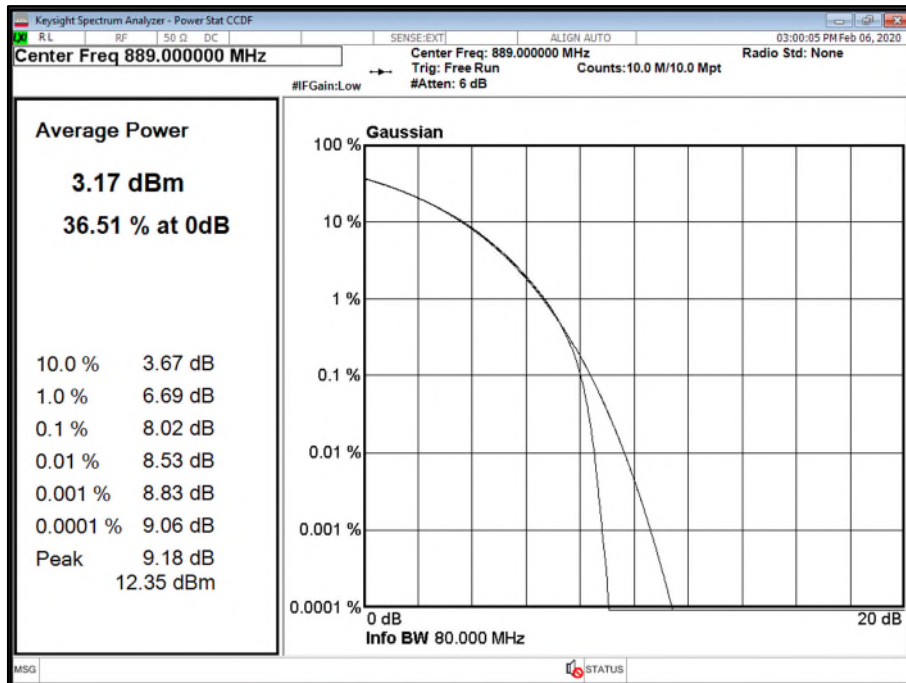

Antenna D - LTE Modulation QPSK - LTE Carrier Bandwidth 10.0 MHz - Channel Position T

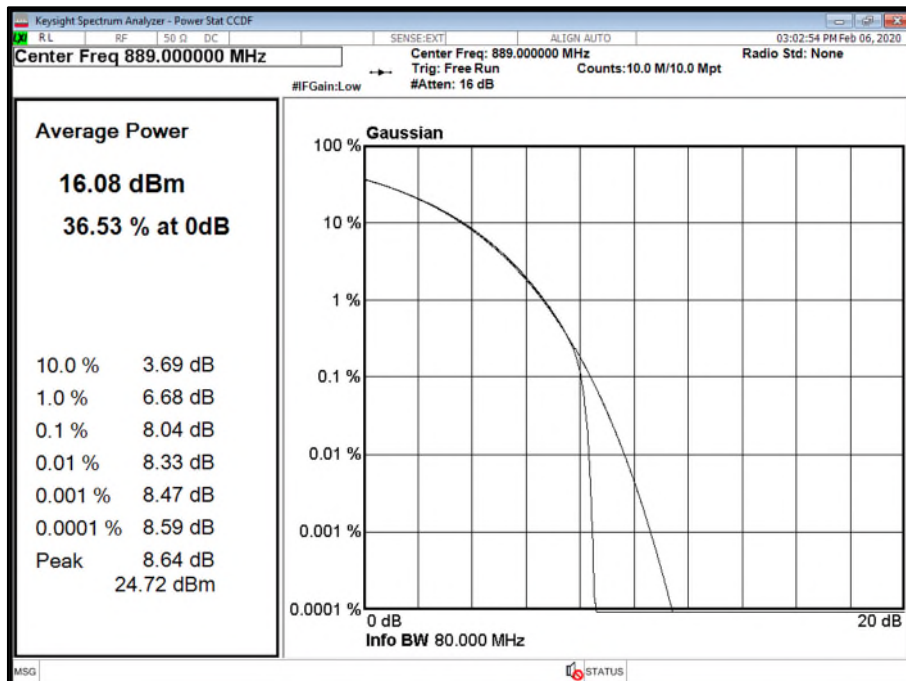



Product Service

Antenna A - LTE Modulation QPSK - LTE Carrier Bandwidth 5.0 MHz - Channel Position T

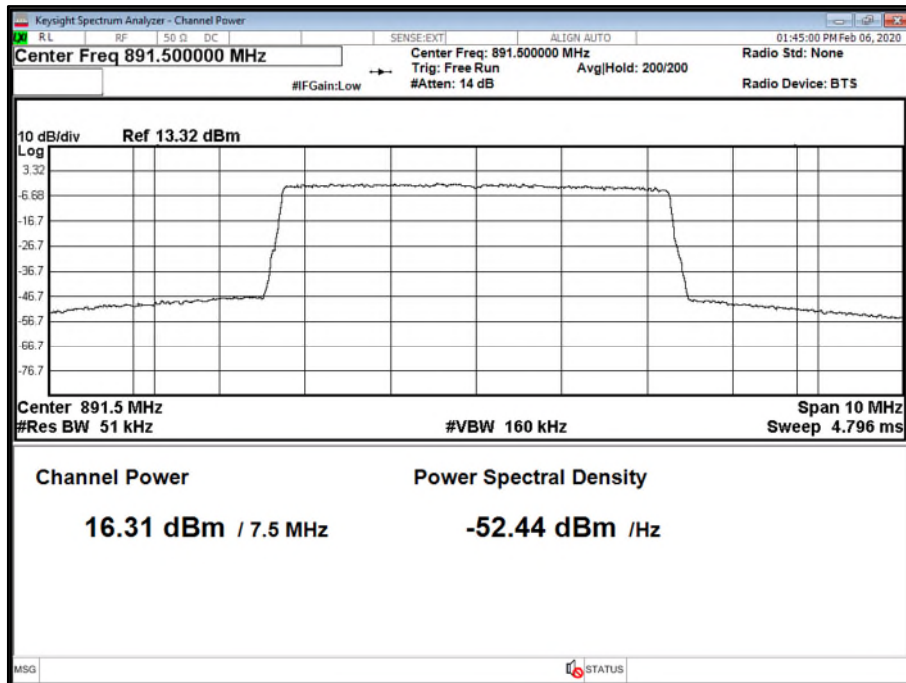

Antenna B - LTE Modulation QPSK - LTE Carrier Bandwidth 5.0 MHz - Channel Position T

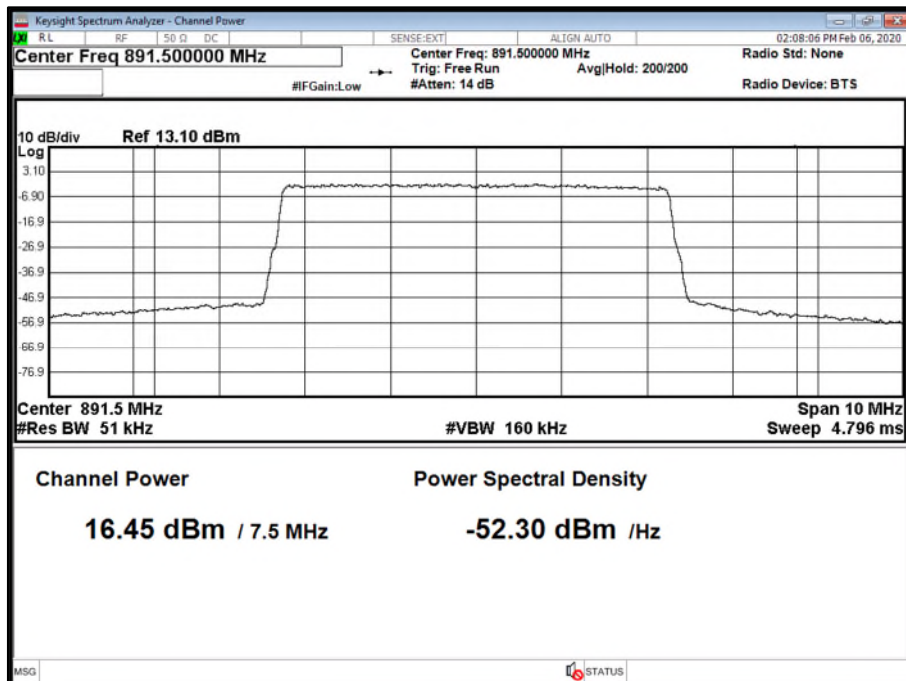



Product Service

Antenna C - LTE Modulation QPSK - LTE Carrier Bandwidth 5.0 MHz - Channel Position T

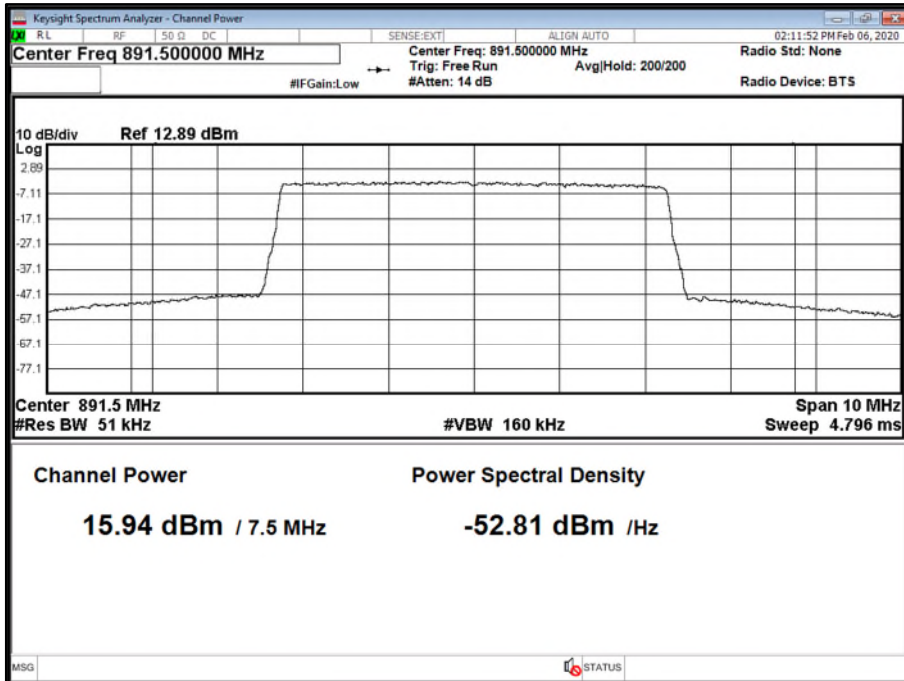

Antenna D - LTE Modulation QPSK - LTE Carrier Bandwidth 5.0 MHz - Channel Position T

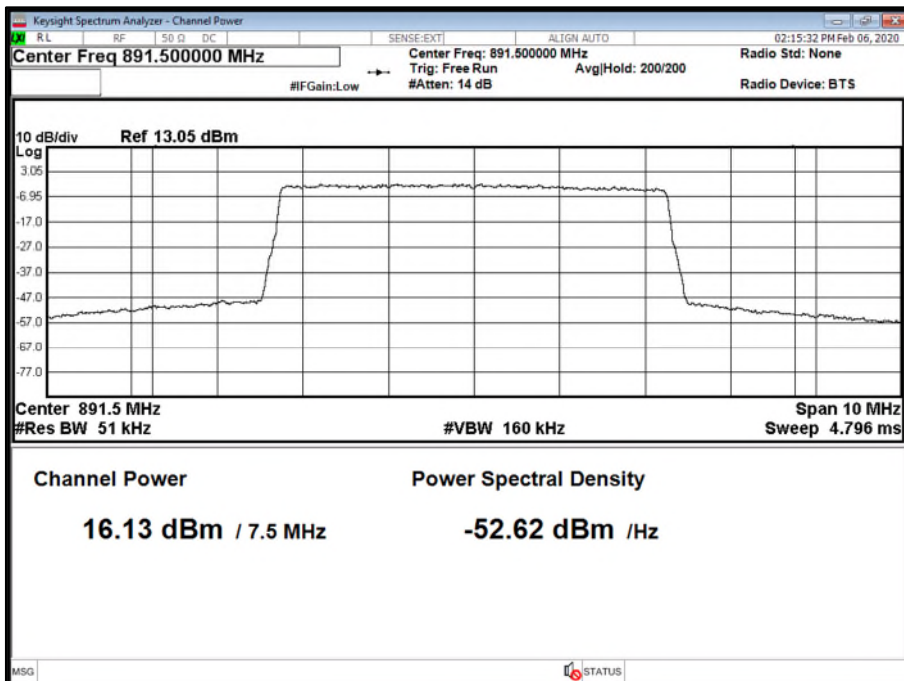



Product Service

Antenna A - LTE Modulation QPSK - LTE Carrier Bandwidth 10.0 MHz - Channel Position T

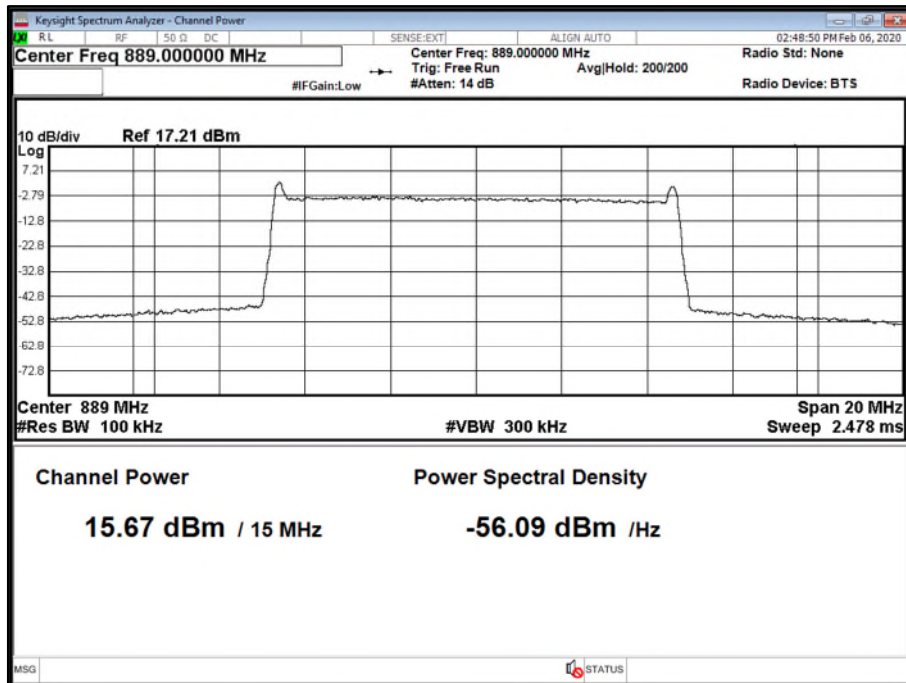

Antenna B - LTE Modulation QPSK - LTE Carrier Bandwidth 10.0 MHz - Channel Position T

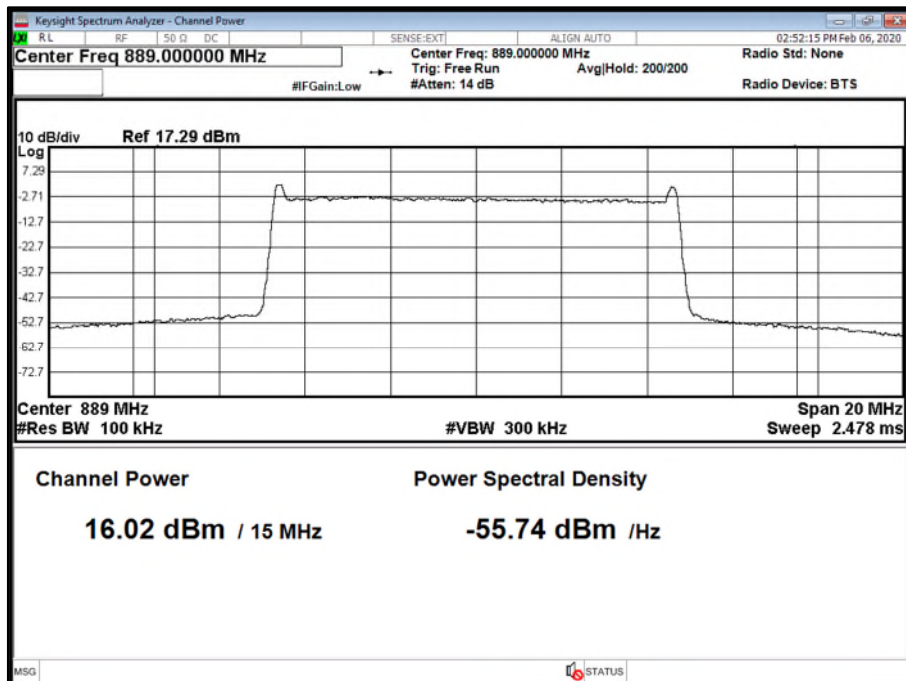



Product Service

Antenna C - LTE Modulation QPSK - LTE Carrier Bandwidth 10.0 MHz - Channel Position T

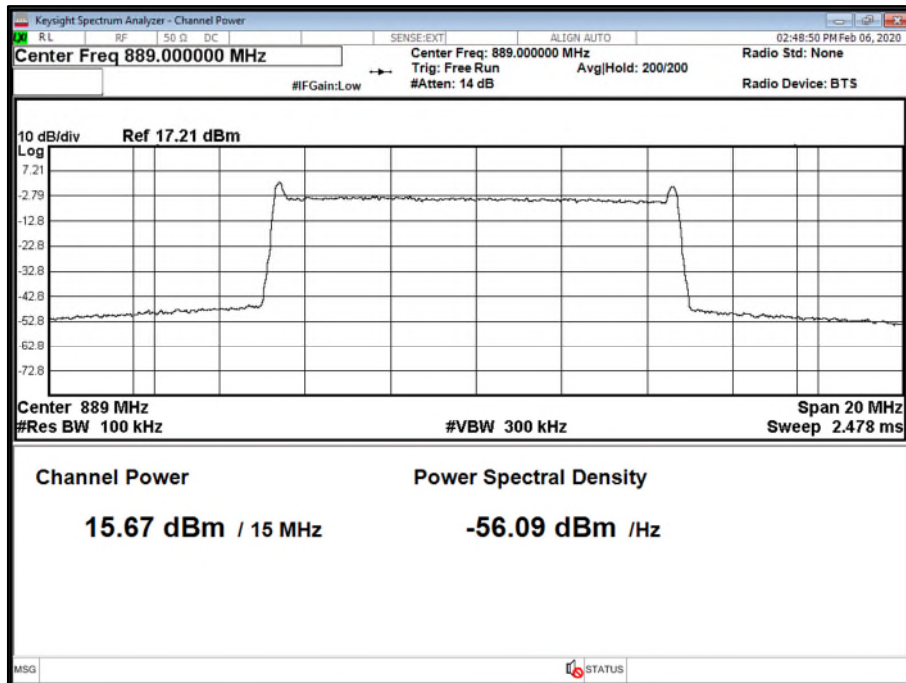

Antenna D - LTE Modulation QPSK - LTE Carrier Bandwidth 10.0 MHz - Channel Position T

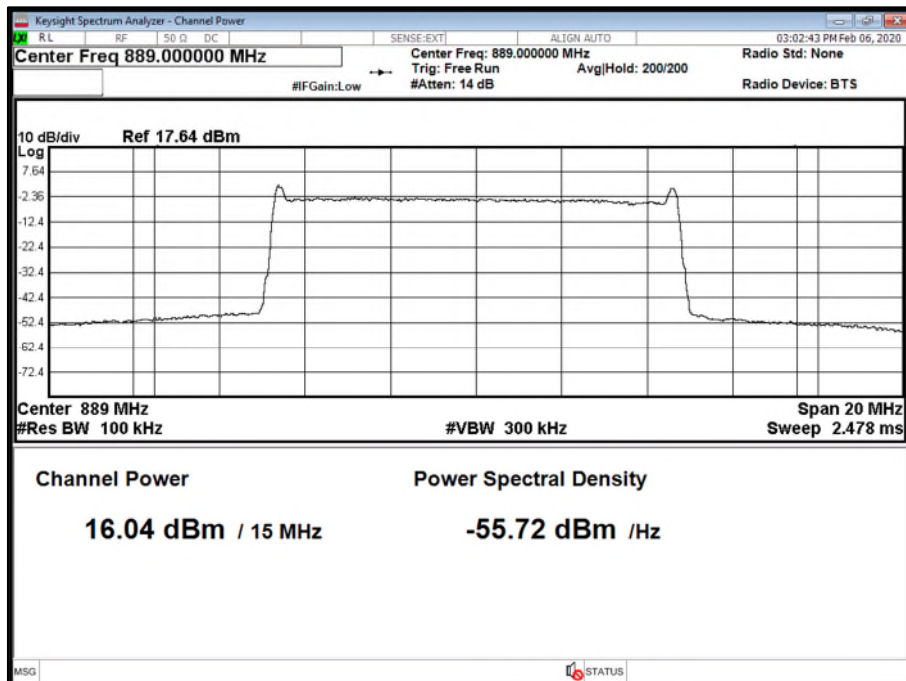



Product Service

Configuration B

Maximum Output Power 17 dBm per port

Antenna	LTE Modulation	LTE Carrier Bandwidth	Peak to Average Ratio (PAR) / Output Power		
			Channel Position M		
			PAR (dB)	Average Power	
dBm	dBm/MHz				
A	QPSK	5.0+5.0+5.0+5.0+5.0 MHz	-	15.86	-
B	QPSK	5.0+5.0+5.0+5.0+5.0 MHz	-	15.91	-
C	QPSK	5.0+5.0+5.0+5.0+5.0 MHz	-	15.85	-
D	QPSK	5.0+5.0+5.0+5.0+5.0 MHz	-	15.85	-
Total			-	21.89	-



Product Service

Antenna A - LTE Modulation QPSK - LTE Carrier Bandwidth 5.0+5.0+5.0+5.0+5.0 MHz - Channel Position M

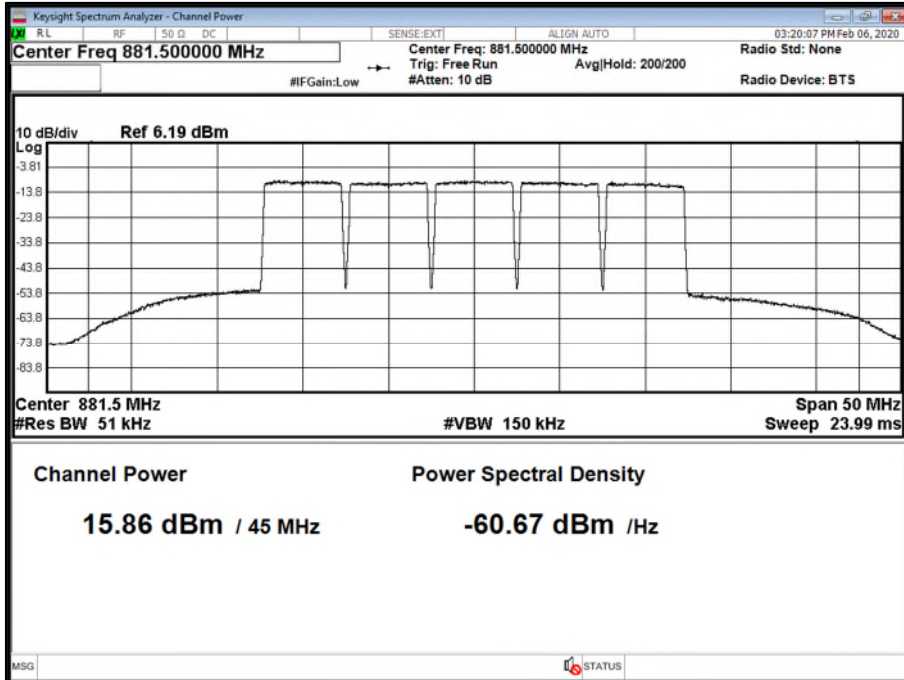

Antenna B - LTE Modulation QPSK - LTE Carrier Bandwidth 5.0+5.0+5.0+5.0+5.0 MHz - Channel Position M

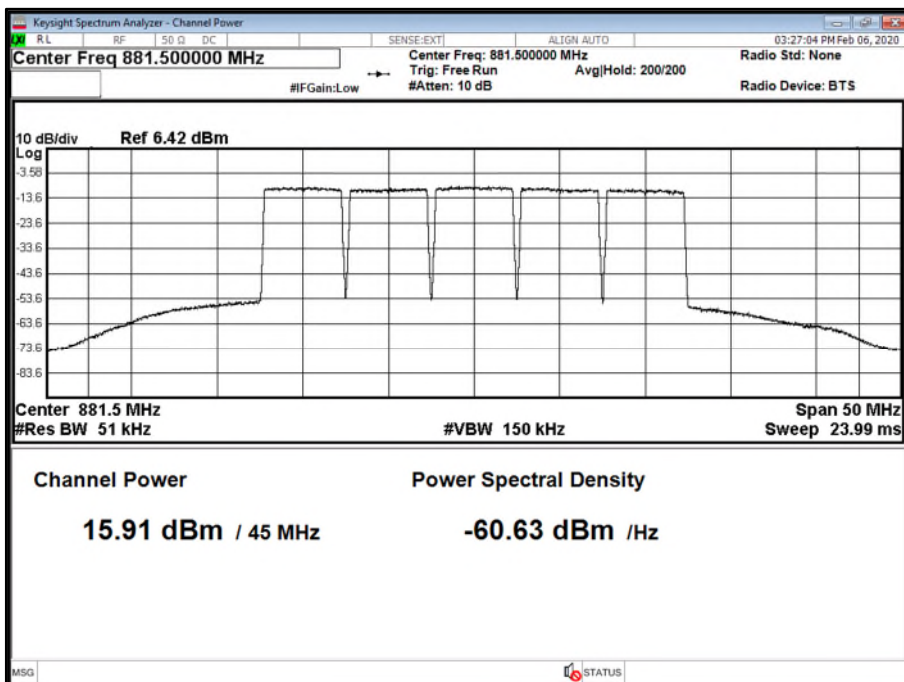



Product Service

Antenna C - LTE Modulation QPSK - LTE Carrier Bandwidth 5.0+5.0+5.0+5.0+5.0 MHz - Channel Position M

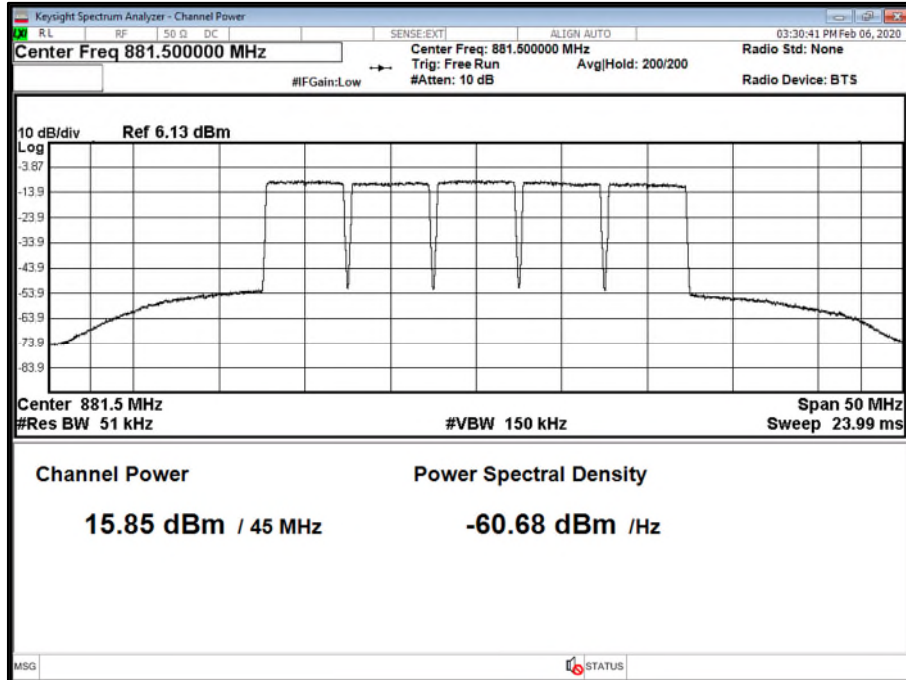

Antenna D - LTE Modulation QPSK - LTE Carrier Bandwidth 5.0+5.0+5.0+5.0+5.0 MHz - Channel Position M

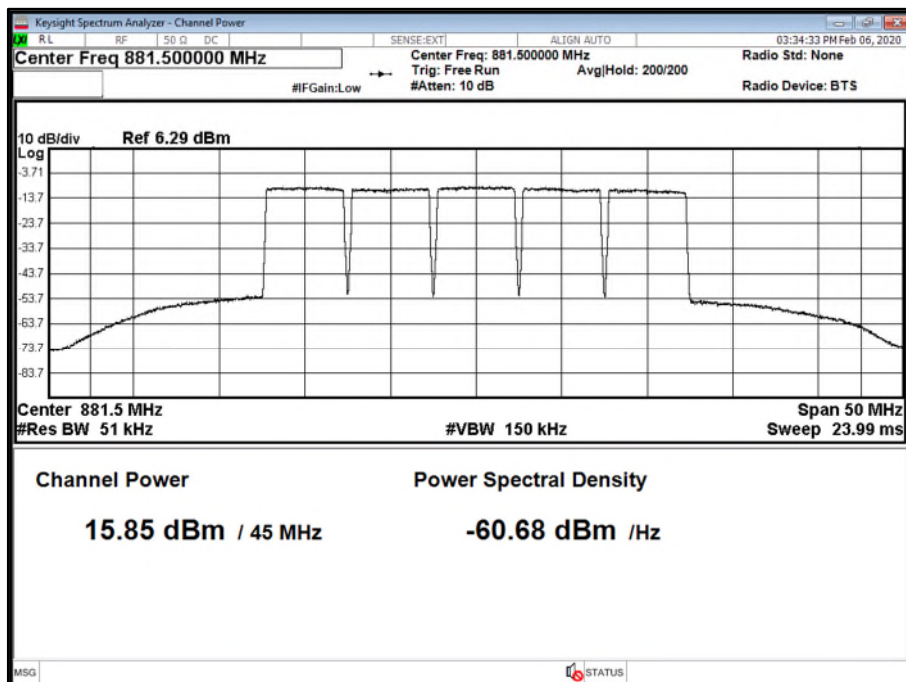



Product Service

Configuration C

Maximum Output Power 17 dBm per port

Antenna	NR Modulation	NR Carrier Bandwidth	Peak to Average Ratio (PAR) / Output Power		
			Channel Position B		
			PAR (dB)	Average Power	
dBm	dBm/MHz				
A	QPSK	5.0 MHz 15 kHz SCS	9.04	16.25	10.62
B	QPSK	5.0 MHz 15 kHz SCS	8.91	16.20	10.40
C	QPSK	5.0 MHz 15 kHz SCS	9.00	16.10	10.36
D	QPSK	5.0 MHz 15 kHz SCS	8.83	16.12	10.40
Total			-	22.19	16.47
A	QPSK	10.0 MHz 15 kHz SCS	9.10	15.87	7.43
B	QPSK	10.0 MHz 15 kHz SCS	9.01	15.74	7.03
C	QPSK	10.0 MHz 15 kHz SCS	9.09	15.69	7.12
D	QPSK	10.0 MHz 15 kHz SCS	9.06	15.80	7.00
Total			-	21.80	13.17
A	QPSK	15.0 MHz 15 kHz SCS	9.27	16.20	5.82
B	QPSK	15.0 MHz 15 kHz SCS	9.10	16.07	5.94
C	QPSK	15.0 MHz 15 kHz SCS	9.27	16.20	5.82
D	QPSK	15.0 MHz 15 kHz SCS	8.99	15.87	5.63
Total			-	22.11	11.82
A	QPSK	20.0 MHz 15 kHz SCS	9.23	16.29	4.51
B	QPSK	20.0 MHz 15 kHz SCS	8.96	16.26	4.56
C	QPSK	20.0 MHz 15 kHz SCS	9.11	15.41	3.65
D	QPSK	20.0 MHz 15 kHz SCS	8.94	16.33	4.67
Total			-	22.11	10.39

Remarks

Transmitter port A presented worst case power/typical performance. These results are included for reference.



Product Service

Antenna A - NR Modulation QPSK - NR Carrier Bandwidth 5.0 MHz 15 kHz SCS - Channel Position B

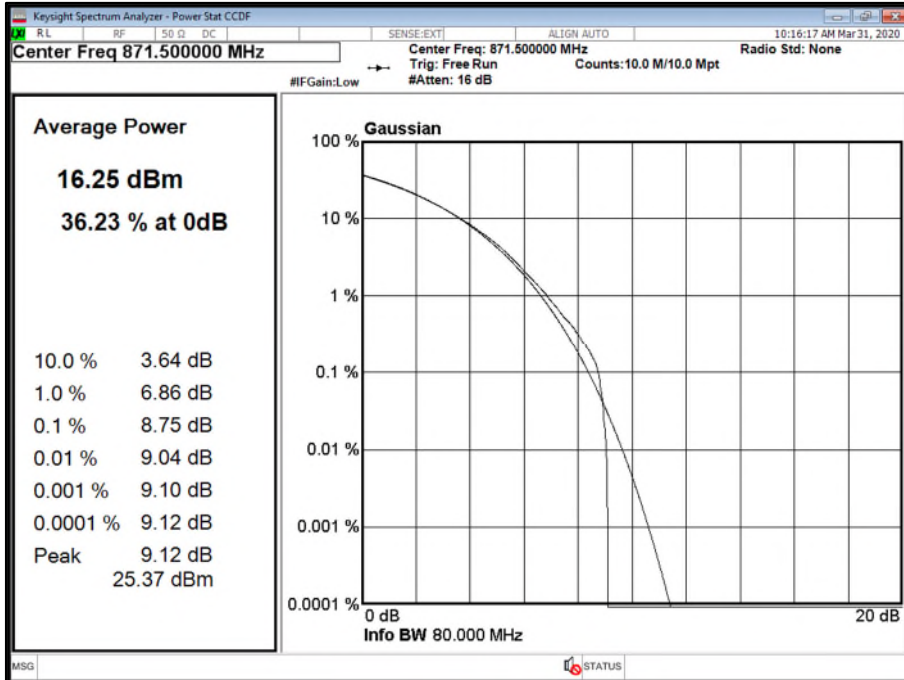

Antenna B - NR Modulation QPSK - NR Carrier Bandwidth 5.0 MHz 15 kHz SCS - Channel Position B

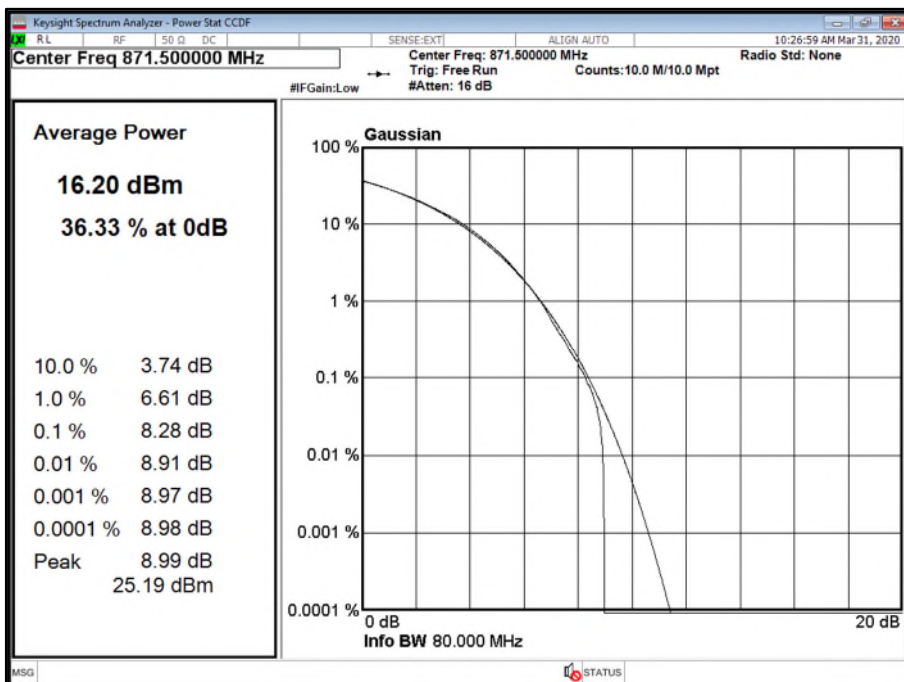



Product Service

Antenna C - NR Modulation QPSK - NR Carrier Bandwidth 5.0 MHz 15 kHz SCS - Channel Position B

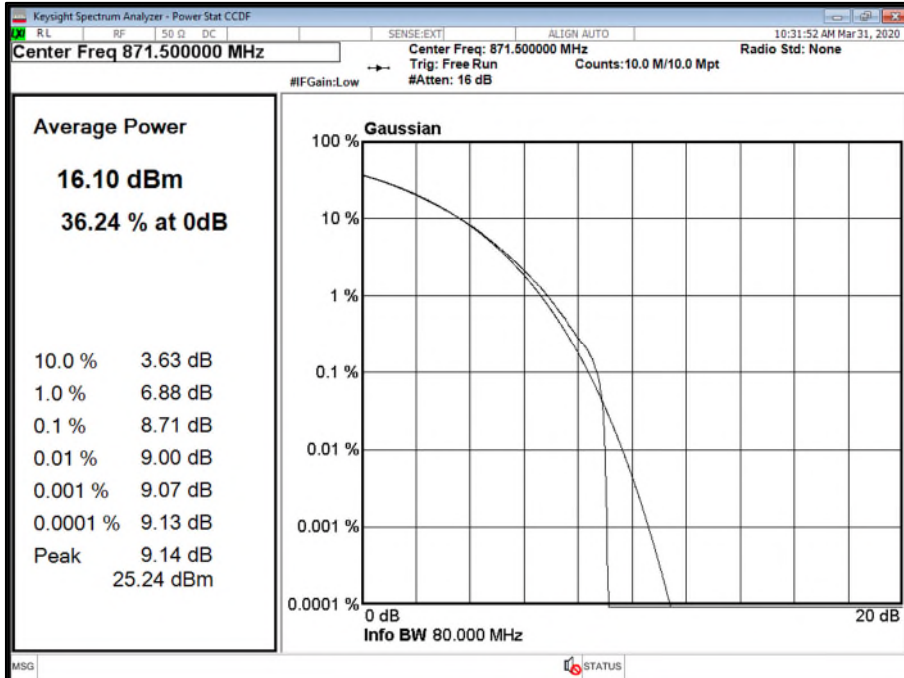

Antenna D - NR Modulation QPSK - NR Carrier Bandwidth 5.0 MHz 15 kHz SCS - Channel Position B

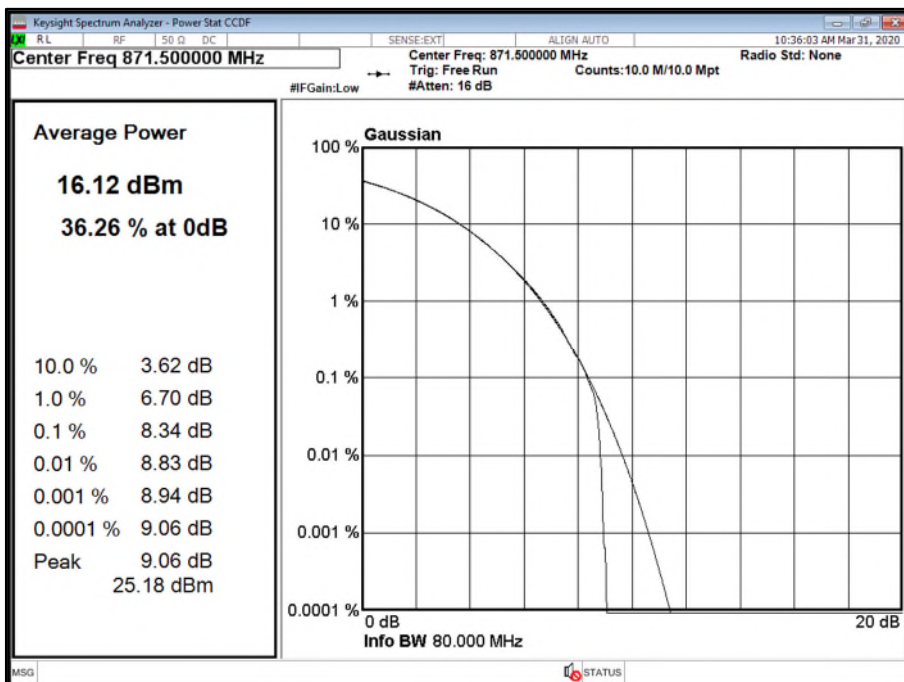



Product Service

Antenna A - NR Modulation QPSK - NR Carrier Bandwidth 10.0 MHz 15 kHz SCS - Channel Position B

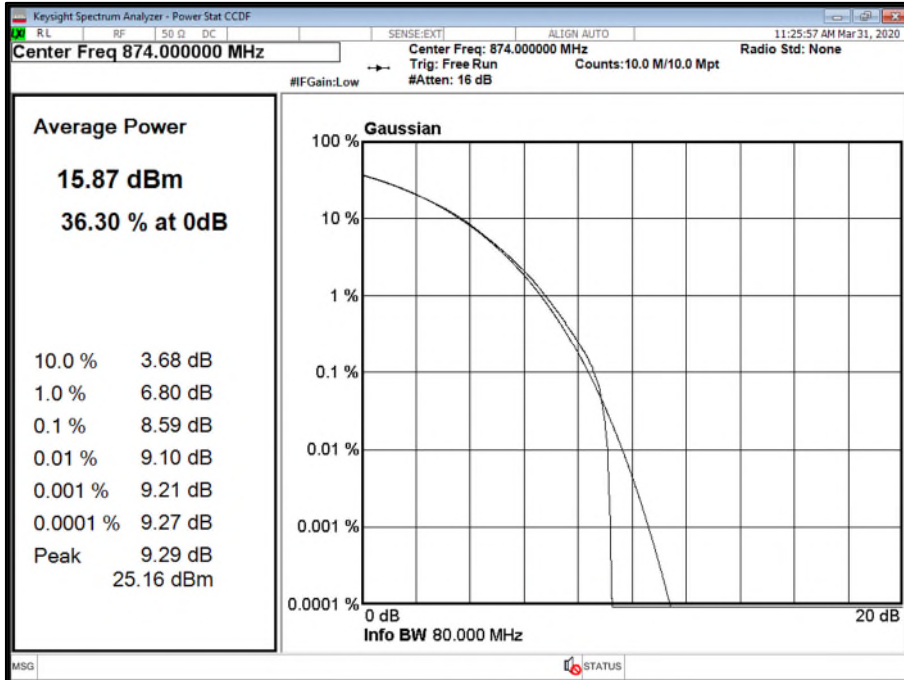

Antenna B - NR Modulation QPSK - NR Carrier Bandwidth 10.0 MHz 15 kHz SCS - Channel Position B

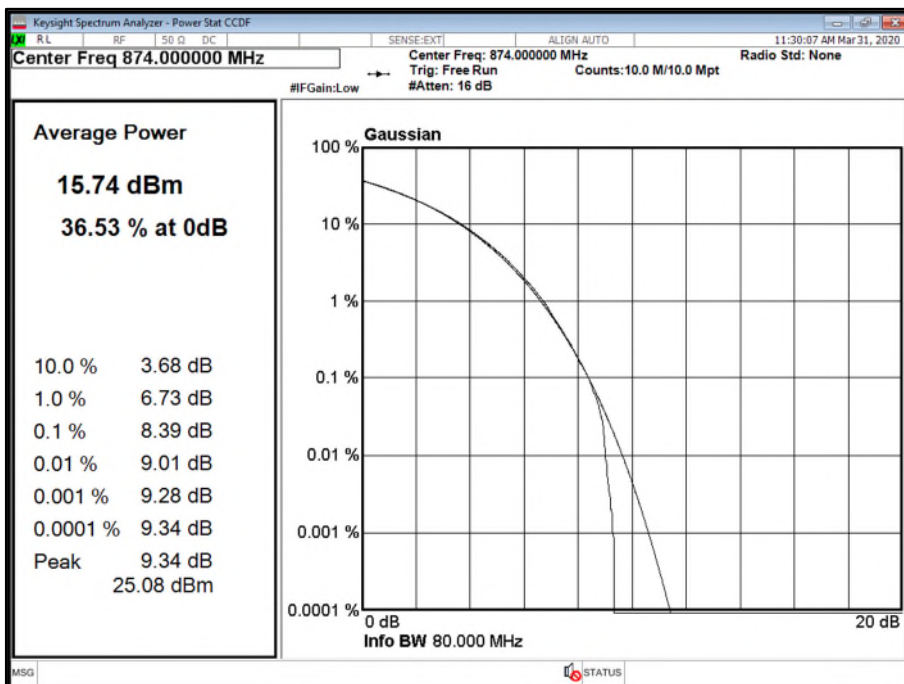



Product Service

Antenna C - NR Modulation QPSK - NR Carrier Bandwidth 10.0 MHz 15 kHz SCS - Channel Position B

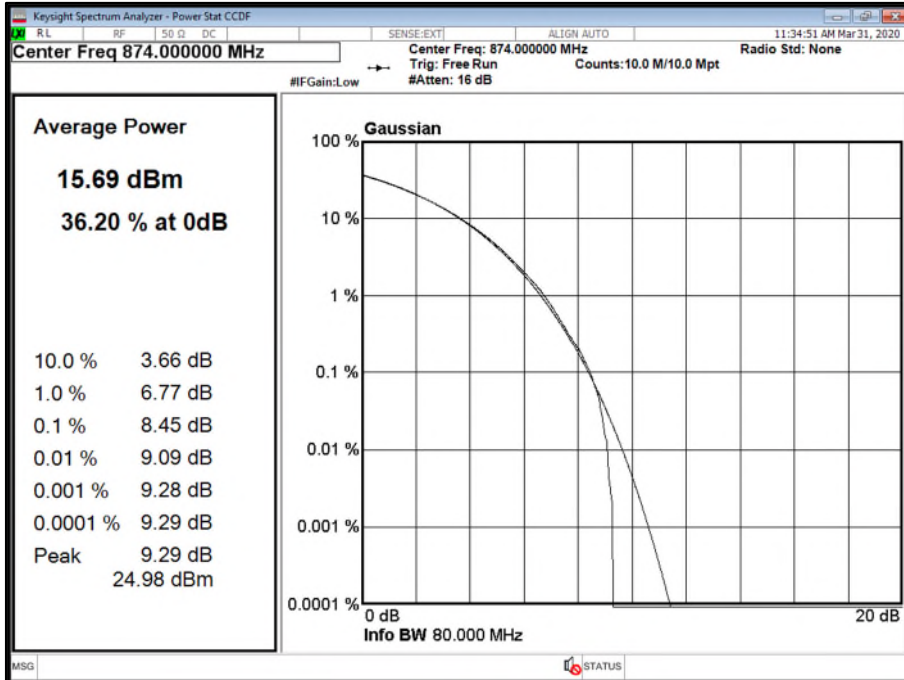

Antenna D - NR Modulation QPSK - NR Carrier Bandwidth 10.0 MHz 15 kHz SCS - Channel Position B

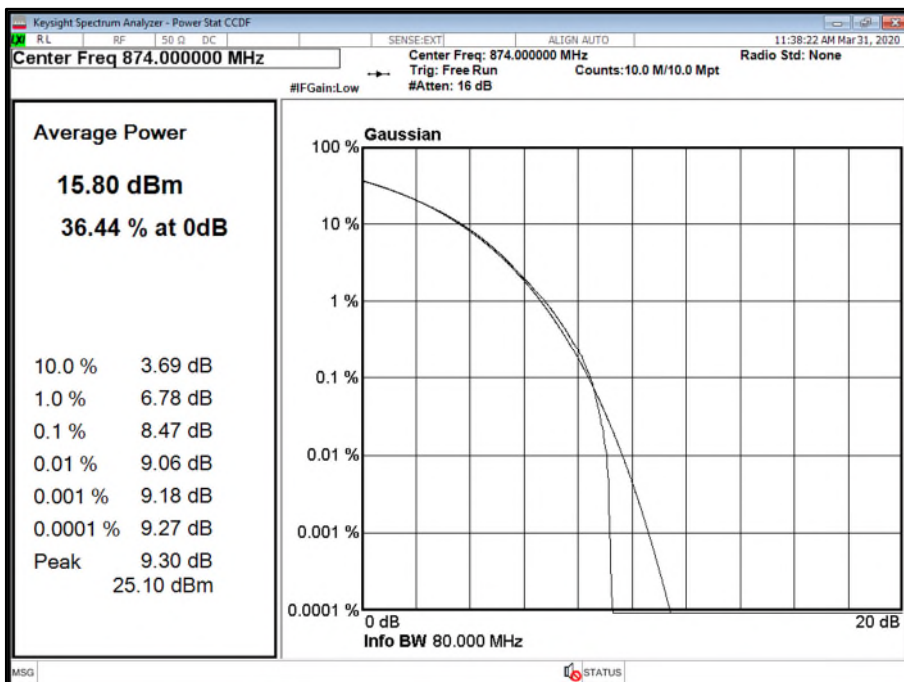



Product Service

Antenna A - NR Modulation QPSK - NR Carrier Bandwidth 15.0 MHz 15 kHz SCS - Channel Position B

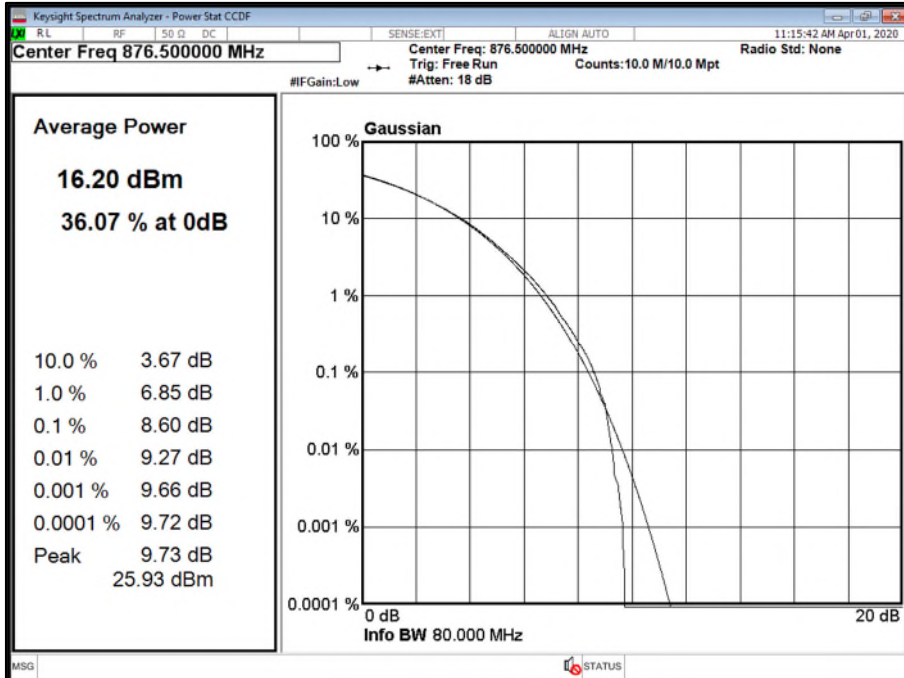

Antenna B - NR Modulation QPSK - NR Carrier Bandwidth 15.0 MHz 15 kHz SCS - Channel Position B

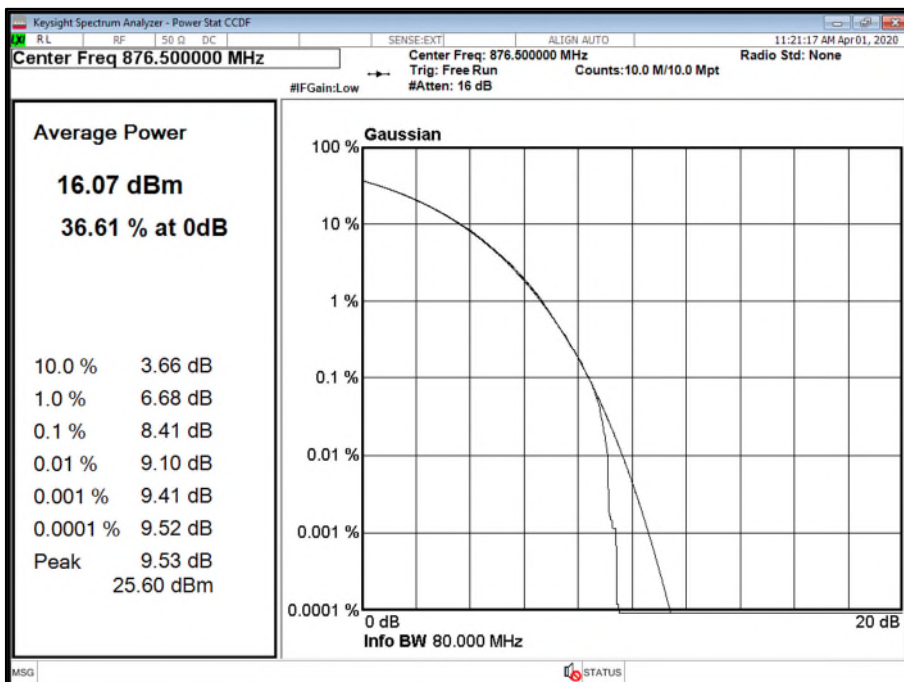



Product Service

Antenna C - NR Modulation QPSK - NR Carrier Bandwidth 15.0 MHz 15 kHz SCS - Channel Position B

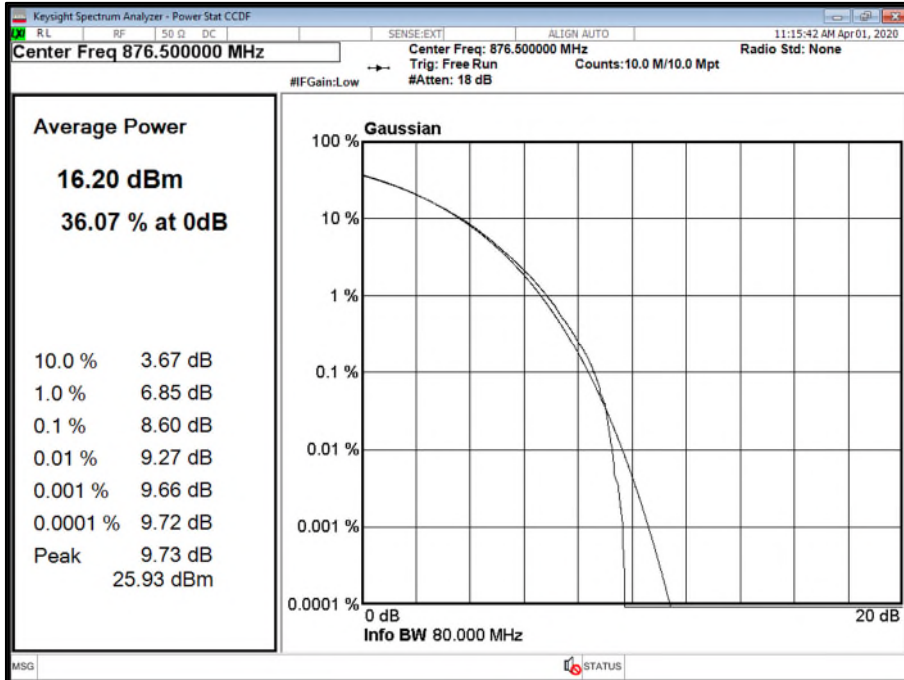

Antenna D - NR Modulation QPSK - NR Carrier Bandwidth 15.0 MHz 15 kHz SCS - Channel Position B

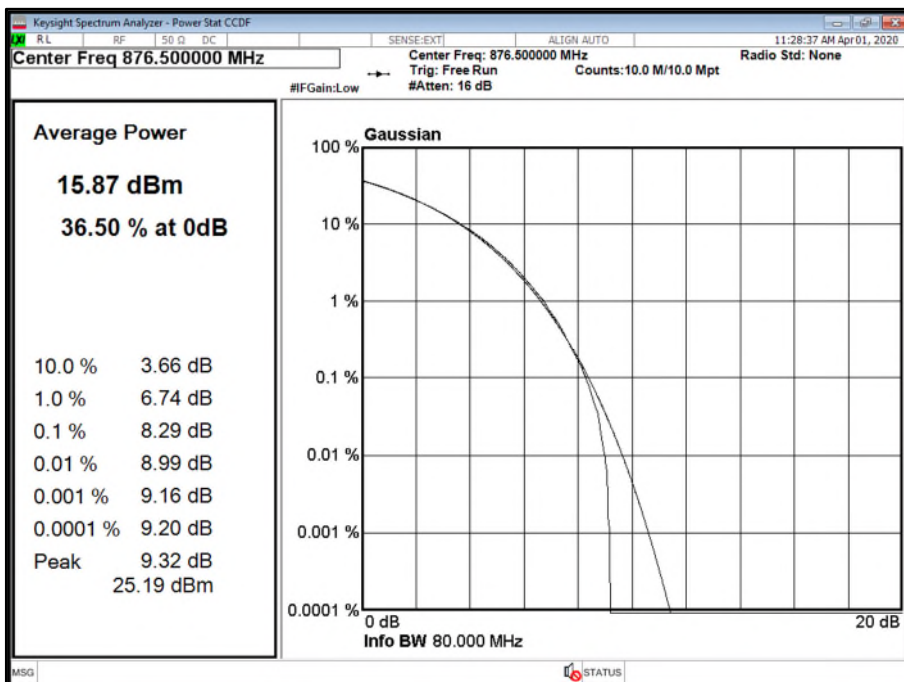



Product Service

Antenna A - NR Modulation QPSK - NR Carrier Bandwidth 20.0 MHz 15 kHz SCS - Channel Position B

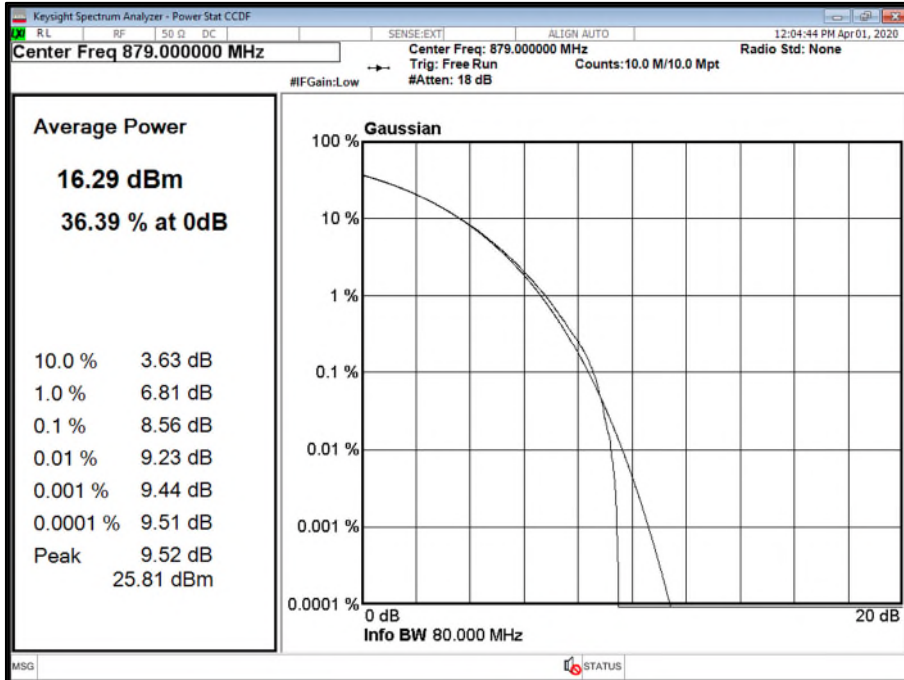

Antenna B - NR Modulation QPSK - NR Carrier Bandwidth 20.0 MHz 15 kHz SCS - Channel Position B

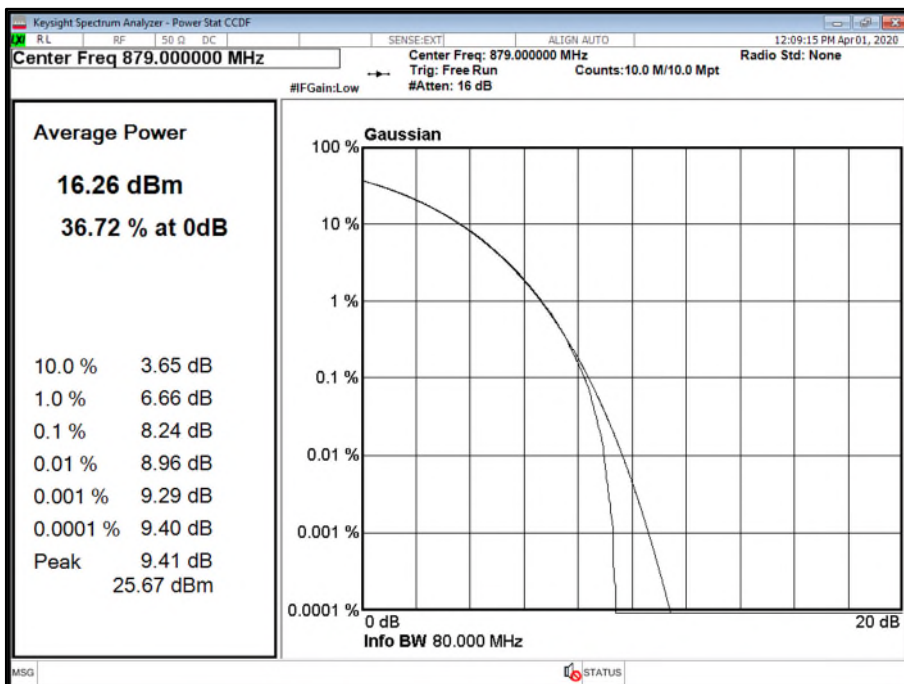



Product Service

Antenna C - NR Modulation QPSK - NR Carrier Bandwidth 20.0 MHz 15 kHz SCS - Channel Position B

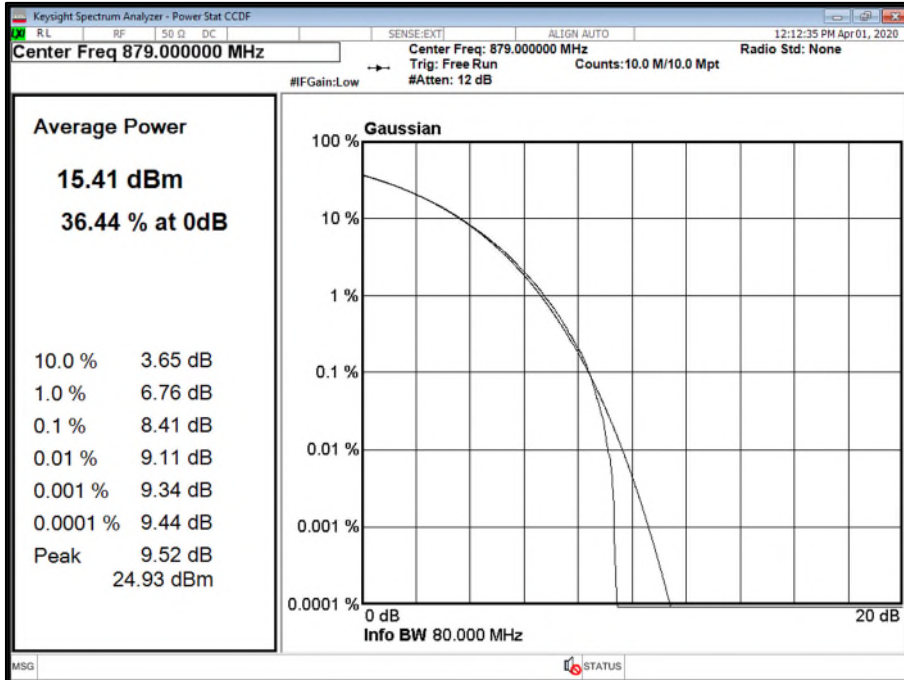

Antenna D - NR Modulation QPSK - NR Carrier Bandwidth 20.0 MHz 15 kHz SCS - Channel Position B

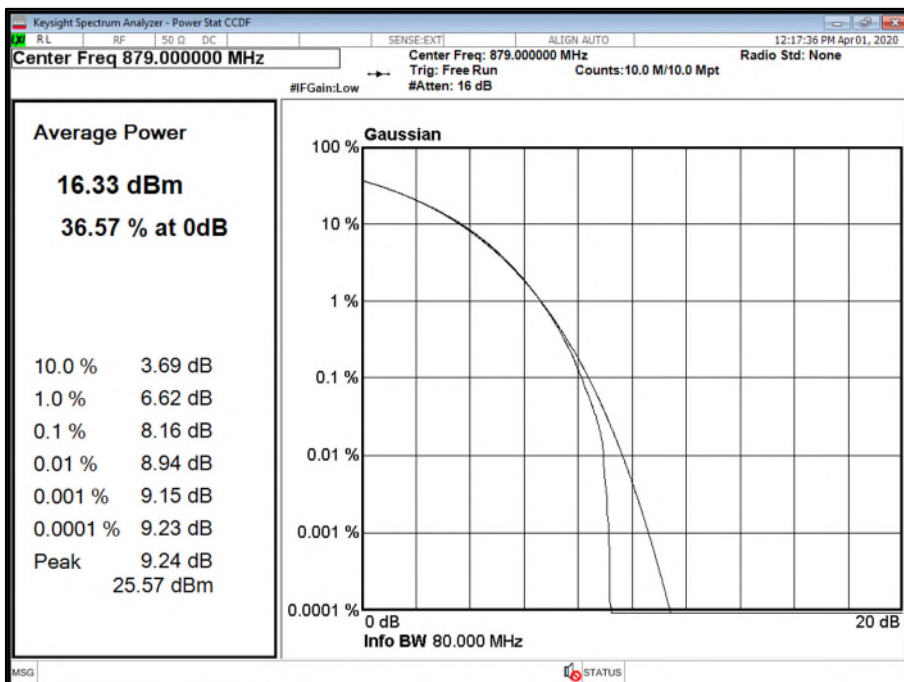



Product Service

Antenna A - NR Modulation QPSK - NR Carrier Bandwidth 5.0 MHz 15 kHz SCS - Channel Position B

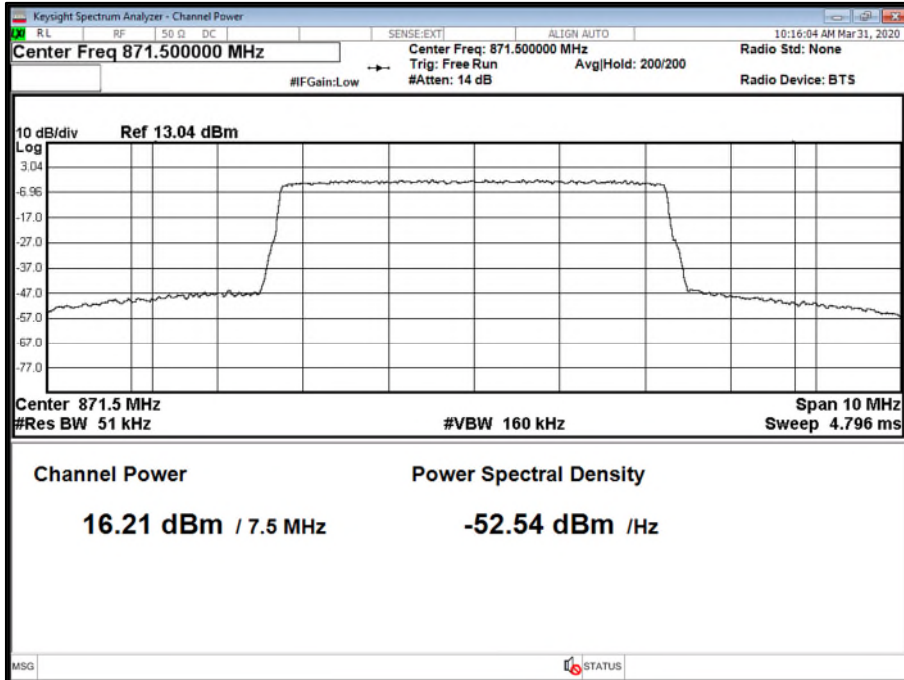

Antenna A - NR Modulation QPSK - NR Carrier Bandwidth 10.0 MHz 15 kHz SCS - Channel Position B

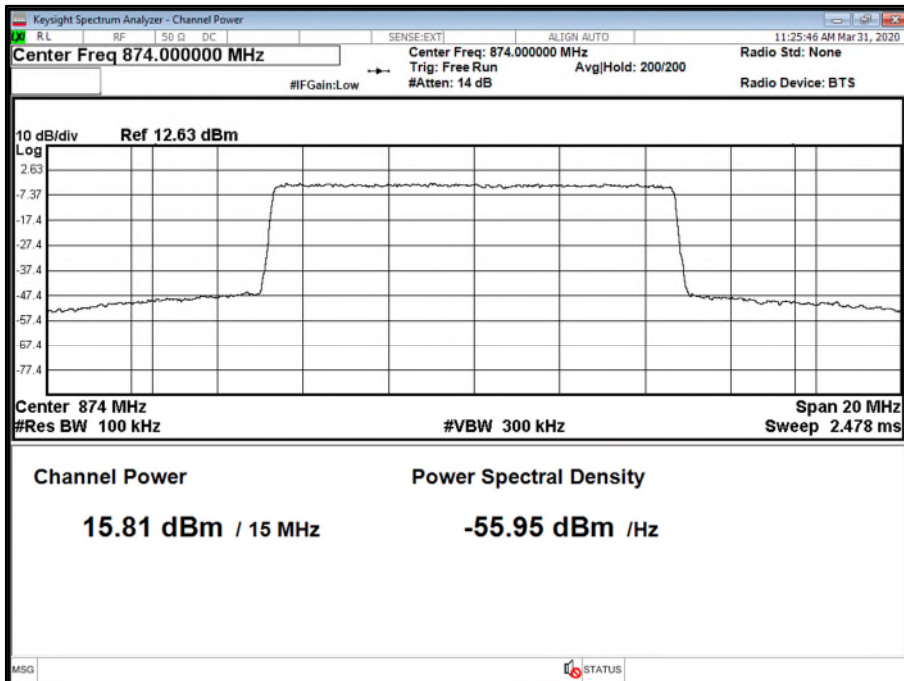



Product Service

Antenna A - NR Modulation QPSK - NR Carrier Bandwidth 15.0 MHz 15 kHz SCS - Channel Position B

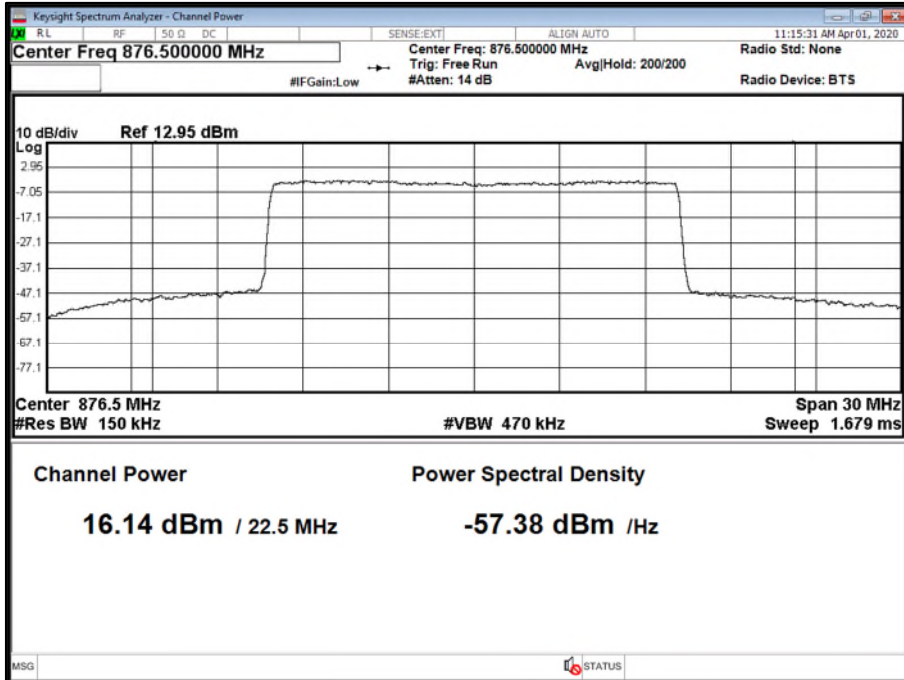

Antenna A - NR Modulation QPSK - NR Carrier Bandwidth 20.0 MHz 15 kHz SCS - Channel Position B

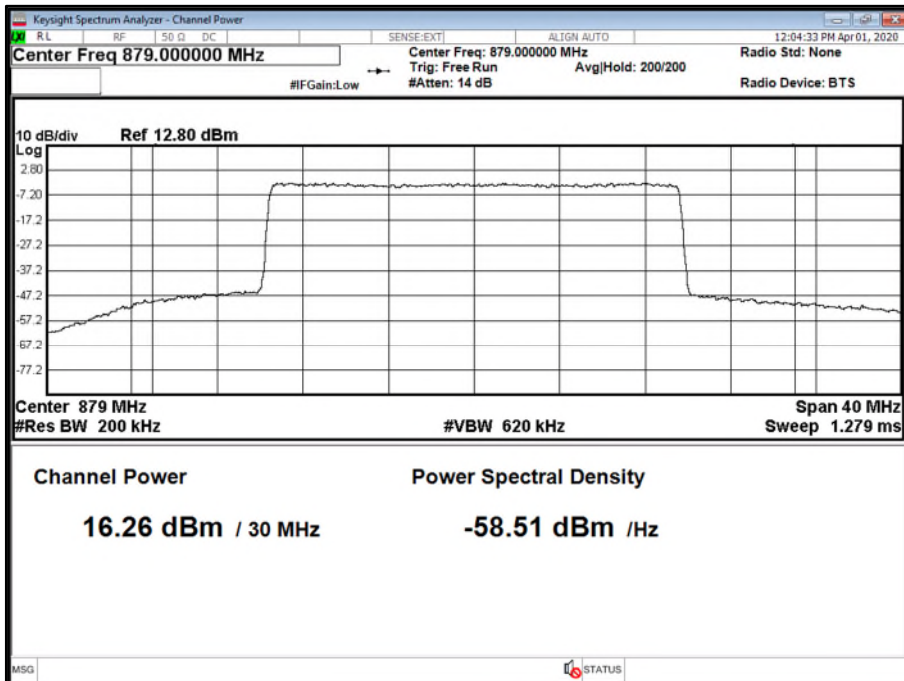



Configuration C

Maximum Output Power 17 dBm per port

Antenna	NR Modulation	NR Carrier Bandwidth	Peak to Average Ratio (PAR) / Output Power		
			Channel Position M		
			PAR (dB)	Average Power	
dBm	dBm/MHz				
A	QPSK	5.0 MHz 15 kHz SCS	9.06	16.16	10.48
B	QPSK	5.0 MHz 15 kHz SCS	8.90	16.23	10.52
C	QPSK	5.0 MHz 15 kHz SCS	8.99	16.07	10.45
D	QPSK	5.0 MHz 15 kHz SCS	8.81	16.14	10.54
Total			-	22.17	16.52
A	QPSK	10.0 MHz 15 kHz SCS	9.07	16.23	7.44
B	QPSK	10.0 MHz 15 kHz SCS	8.95	15.70	7.04
C	QPSK	10.0 MHz 15 kHz SCS	8.99	15.58	6.74
D	QPSK	10.0 MHz 15 kHz SCS	8.94	15.88	7.01
Total			-	21.88	13.09
A	QPSK	15.0 MHz 15 kHz SCS	9.18	16.15	5.89
B	QPSK	15.0 MHz 15 kHz SCS	9.02	16.06	6.03
C	QPSK	15.0 MHz 15 kHz SCS	9.10	15.66	5.38
D	QPSK	15.0 MHz 15 kHz SCS	8.91	15.95	5.44
Total			-	21.98	11.71
A	QPSK	20.0 MHz 15 kHz SCS	9.10	15.78	4.08
B	QPSK	20.0 MHz 15 kHz SCS	8.94	16.30	4.78
C	QPSK	20.0 MHz 15 kHz SCS	9.02	16.35	4.64
D	QPSK	20.0 MHz 15 kHz SCS	8.92	16.37	4.90
Total			-	22.23	10.63

Remarks

Transmitter port A presented worst case power/typical performance. These results are included for reference.



Product Service

Antenna A - NR Modulation QPSK - NR Carrier Bandwidth 5.0 MHz 15 kHz SCS - Channel Position M

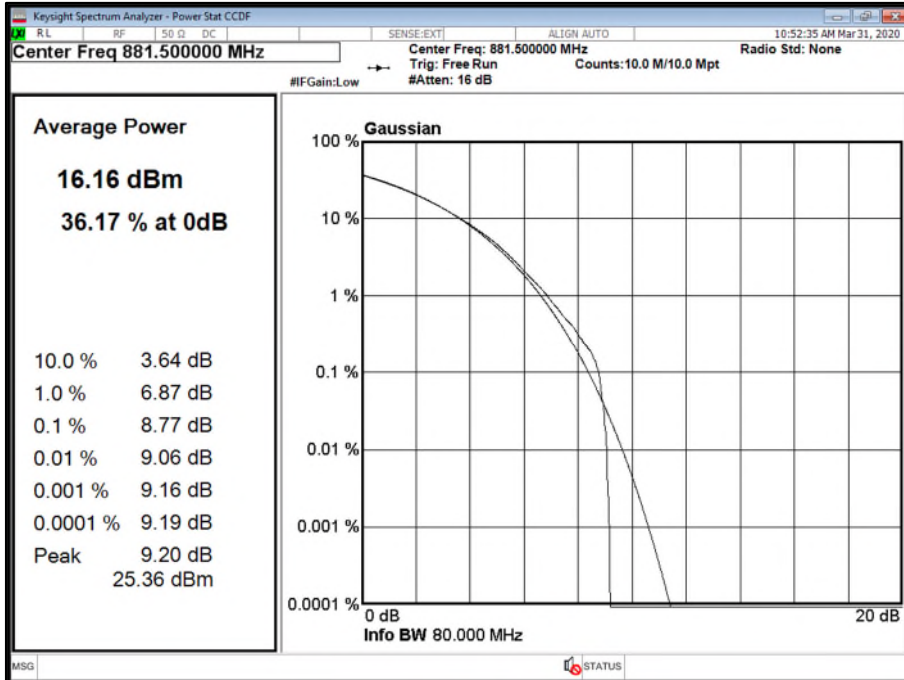

Antenna B - NR Modulation QPSK - NR Carrier Bandwidth 5.0 MHz 15 kHz SCS - Channel Position M

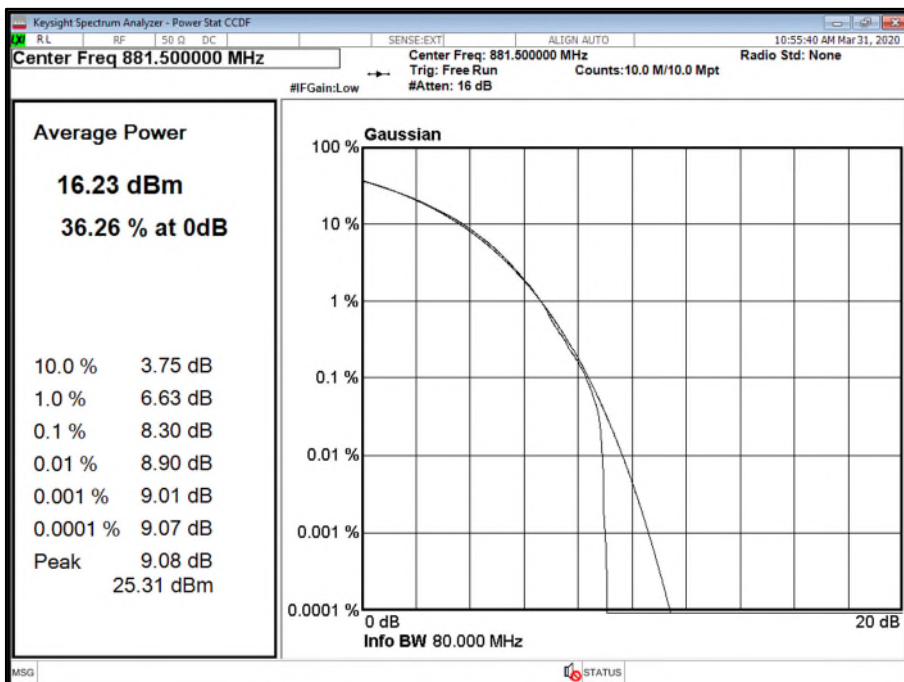



Product Service

Antenna C - NR Modulation QPSK - NR Carrier Bandwidth 5.0 MHz 15 kHz SCS - Channel Position M

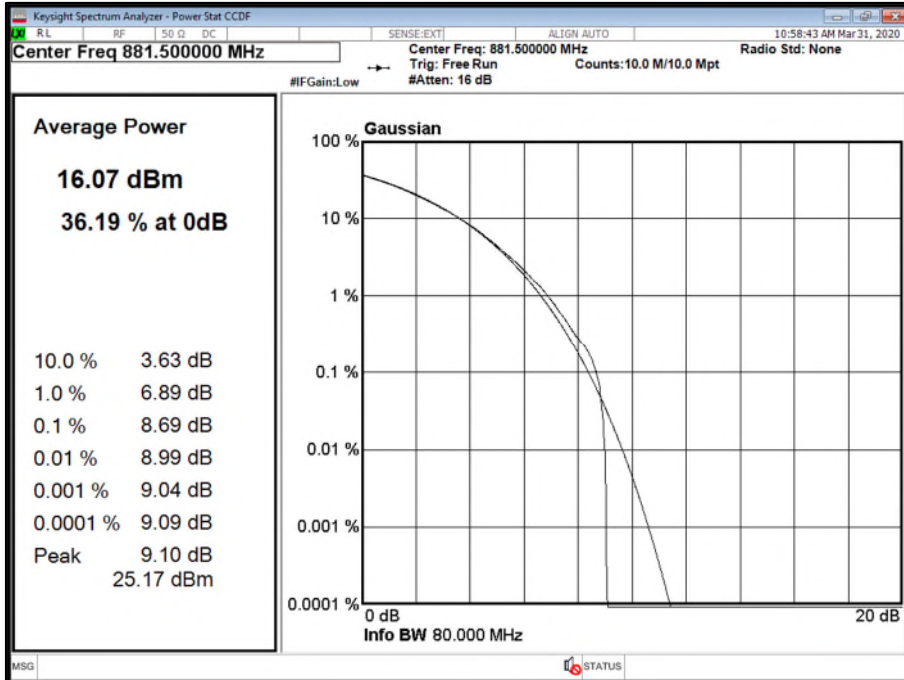

Antenna D - NR Modulation QPSK - NR Carrier Bandwidth 5.0 MHz 15 kHz SCS - Channel Position M

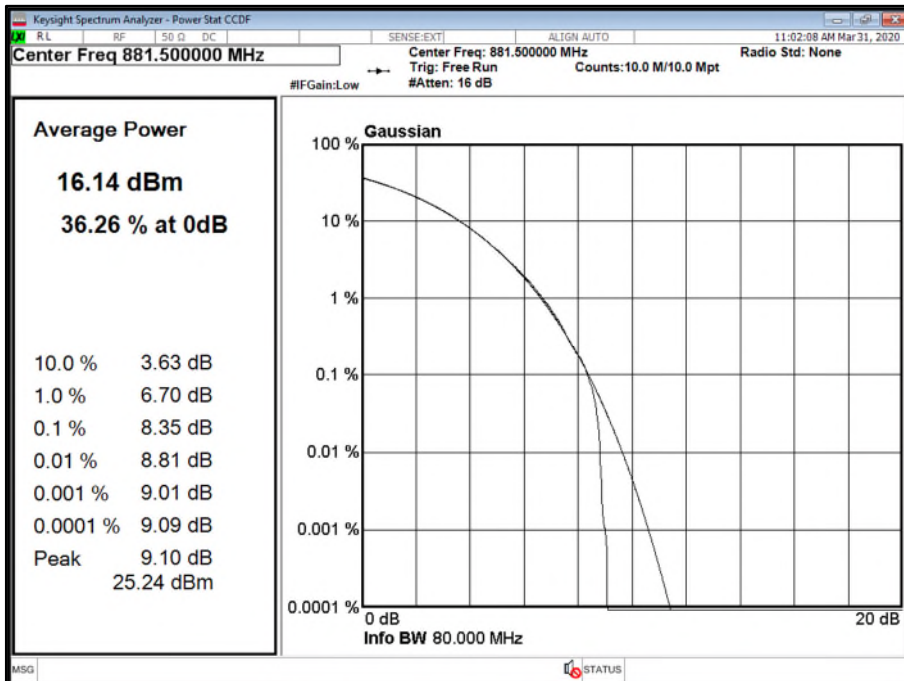



Product Service

Antenna A - NR Modulation QPSK - NR Carrier Bandwidth 10.0 MHz 15 kHz SCS - Channel Position M

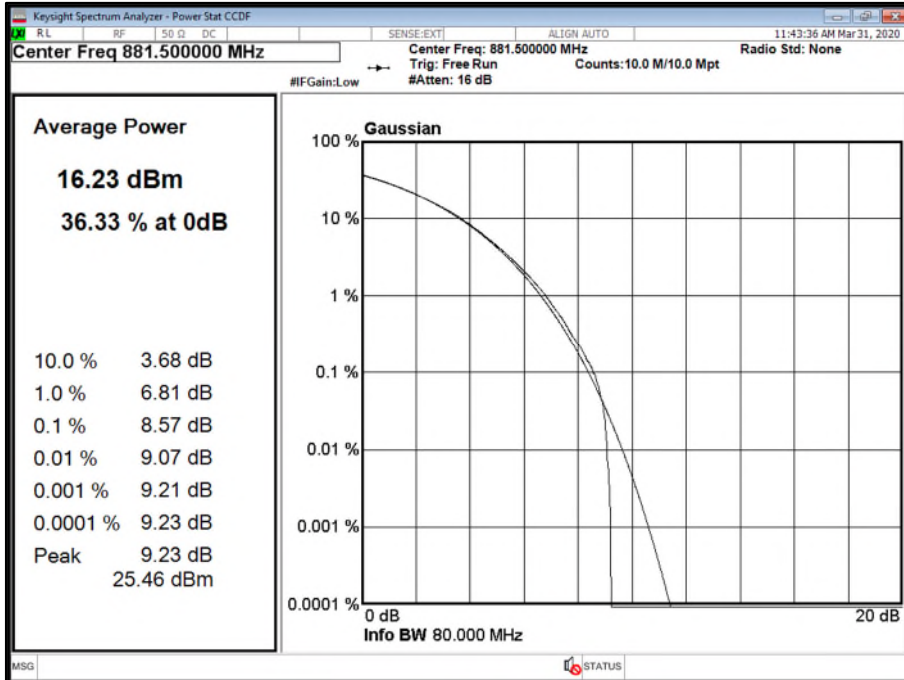

Antenna B - NR Modulation QPSK - NR Carrier Bandwidth 10.0 MHz 15 kHz SCS - Channel Position M

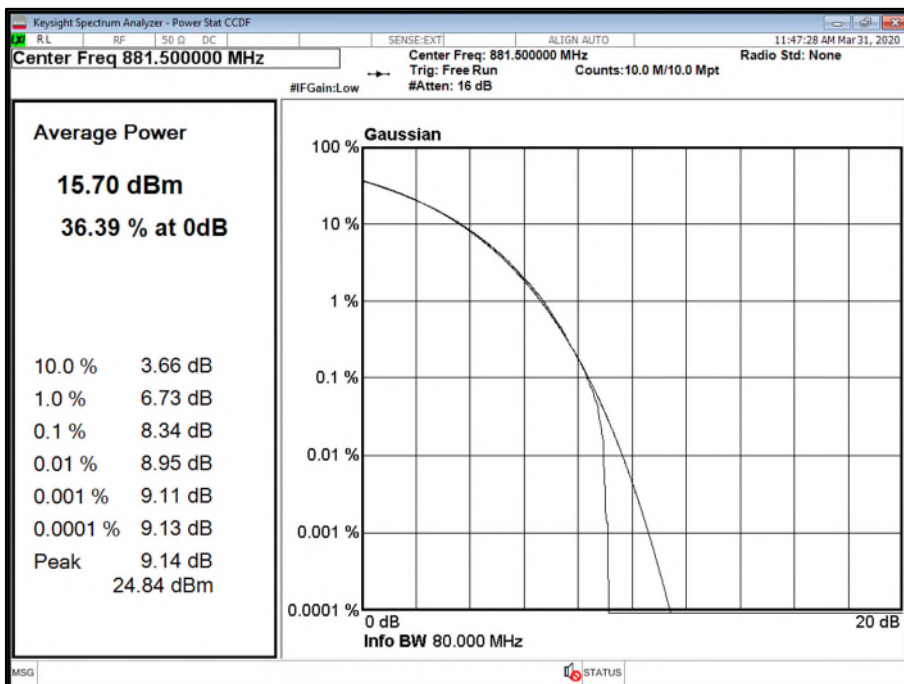



Product Service

Antenna C - NR Modulation QPSK - NR Carrier Bandwidth 10.0 MHz 15 kHz SCS - Channel Position M

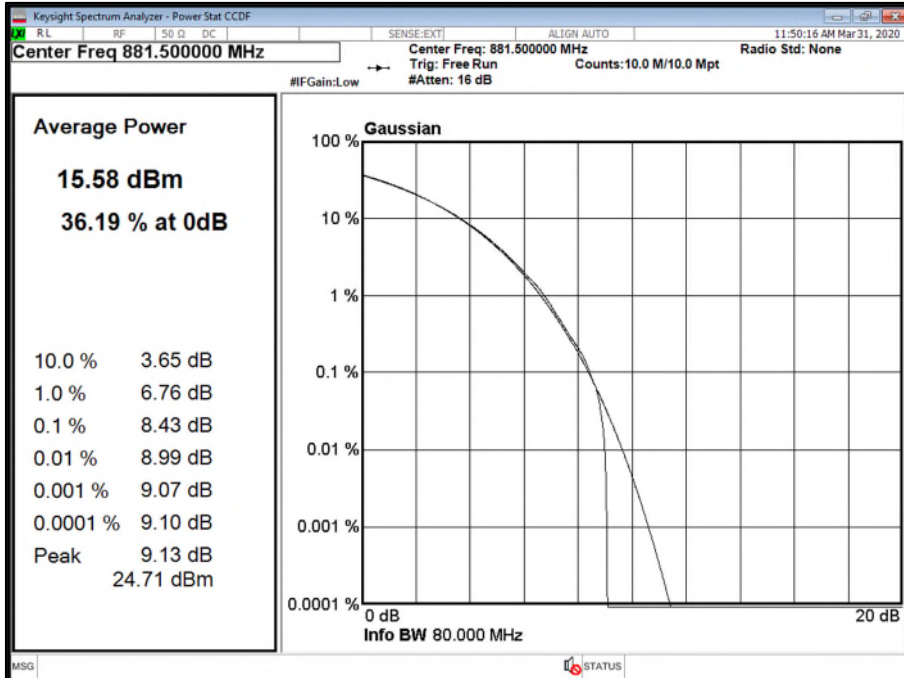

Antenna D - NR Modulation QPSK - NR Carrier Bandwidth 10.0 MHz 15 kHz SCS - Channel Position M

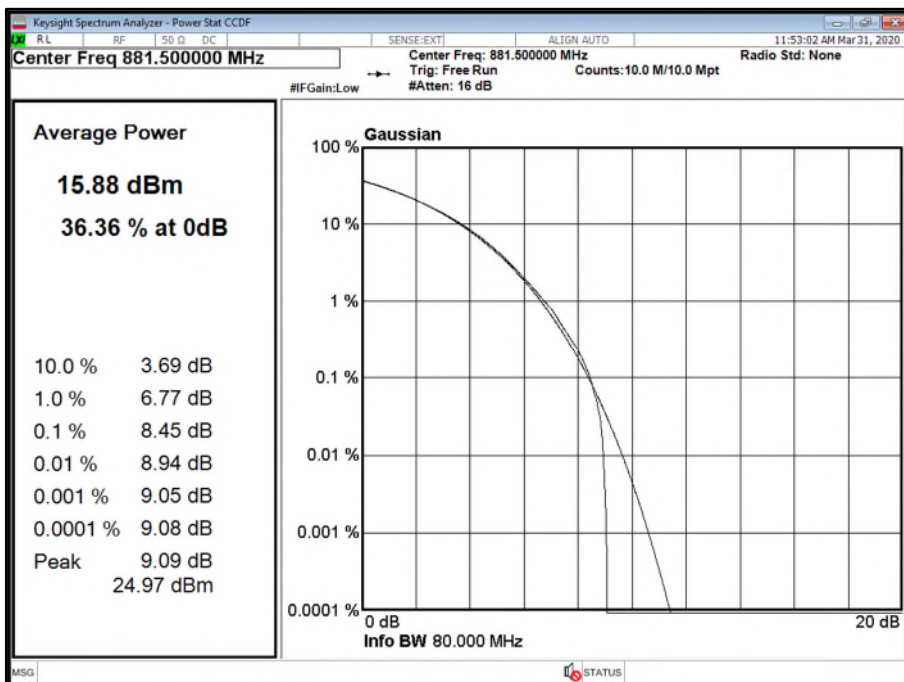



Product Service

Antenna A - NR Modulation QPSK - NR Carrier Bandwidth 15.0 MHz 15 kHz SCS - Channel Position M

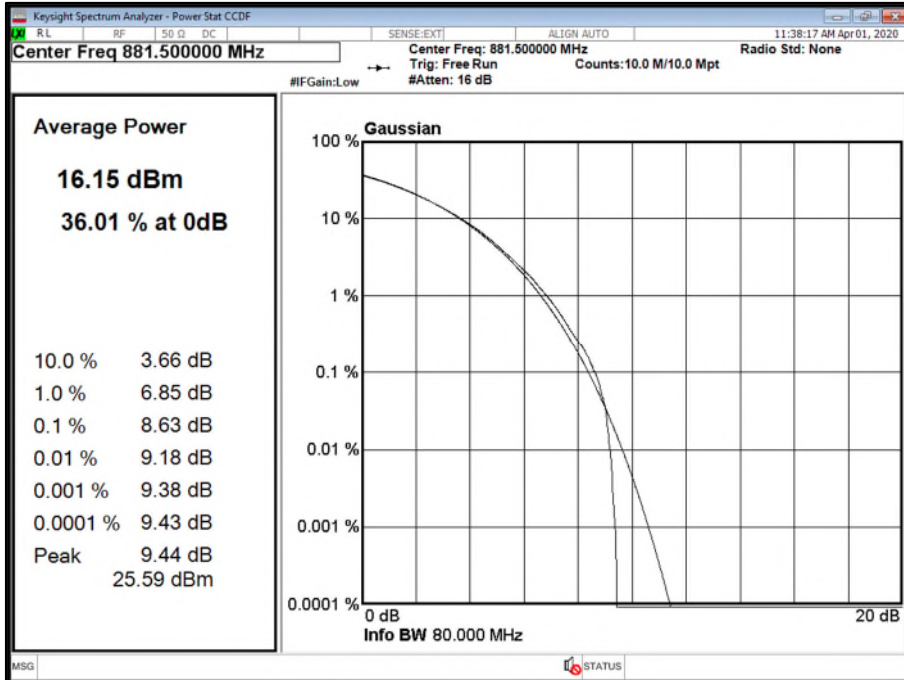

Antenna B - NR Modulation QPSK - NR Carrier Bandwidth 15.0 MHz 15 kHz SCS - Channel Position M

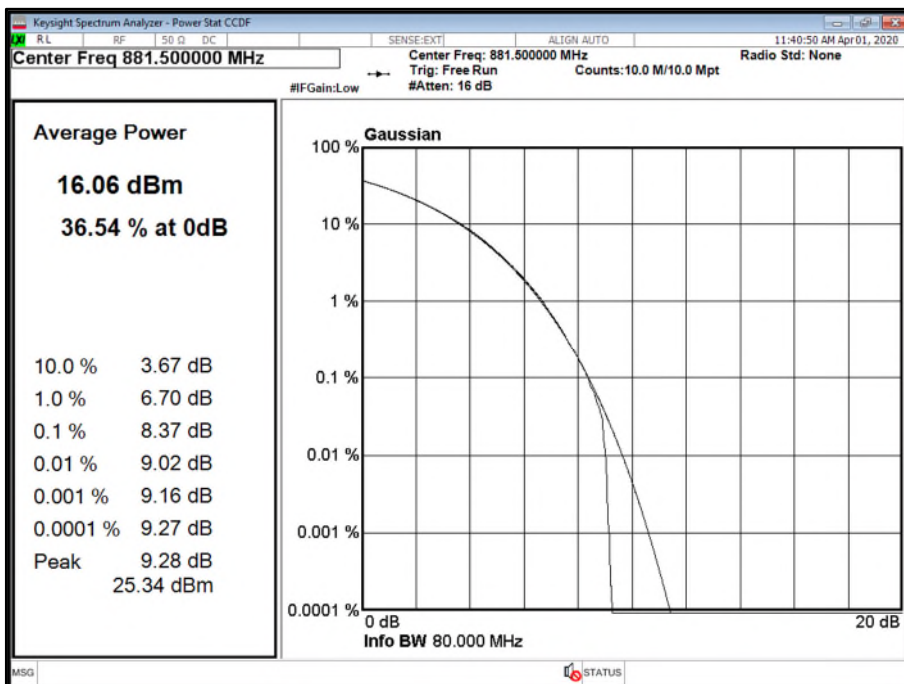



Product Service

Antenna C - NR Modulation QPSK - NR Carrier Bandwidth 15.0 MHz 15 kHz SCS - Channel Position M

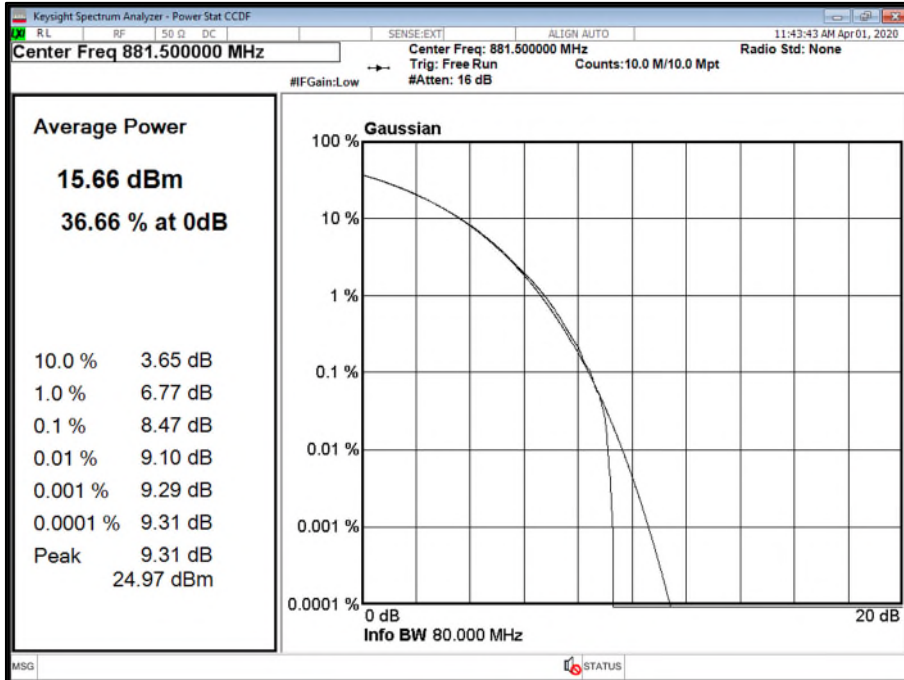

Antenna D - NR Modulation QPSK - NR Carrier Bandwidth 15.0 MHz 15 kHz SCS - Channel Position M

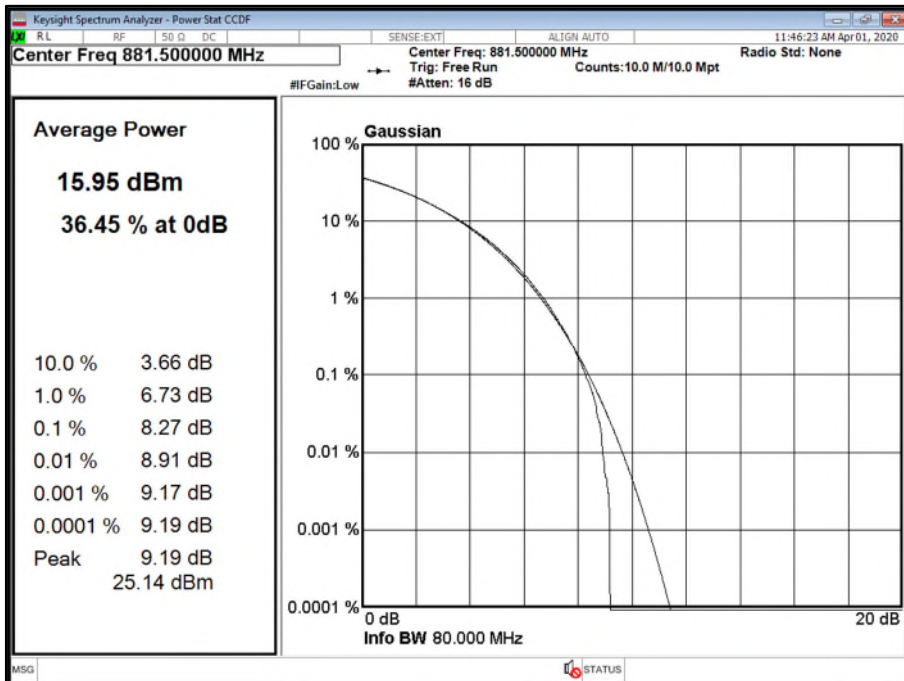



Product Service

Antenna A - NR Modulation QPSK - NR Carrier Bandwidth 20.0 MHz 15 kHz SCS - Channel Position M

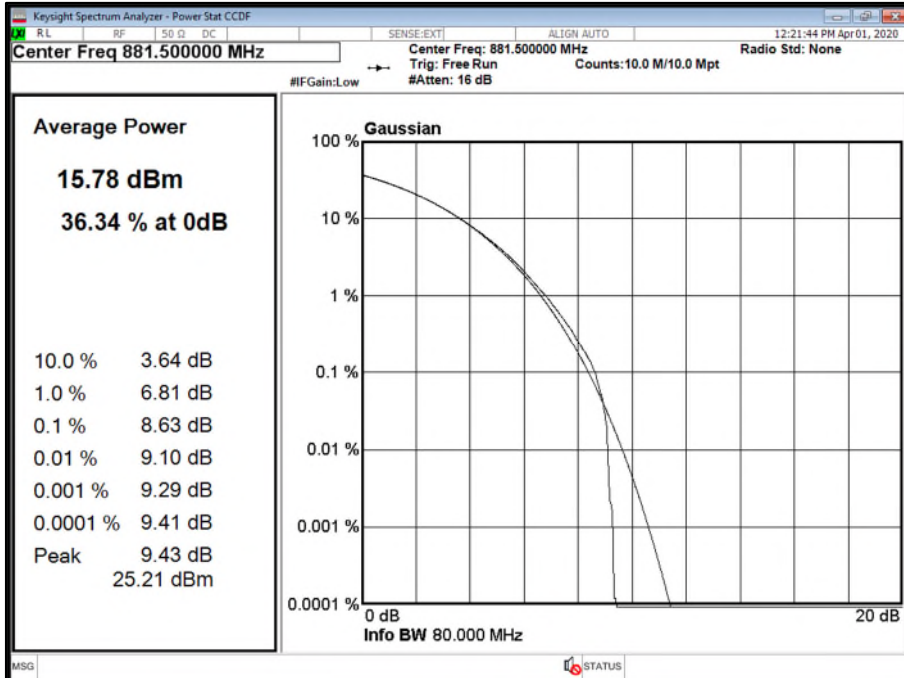

Antenna B - NR Modulation QPSK - NR Carrier Bandwidth 20.0 MHz 15 kHz SCS - Channel Position M

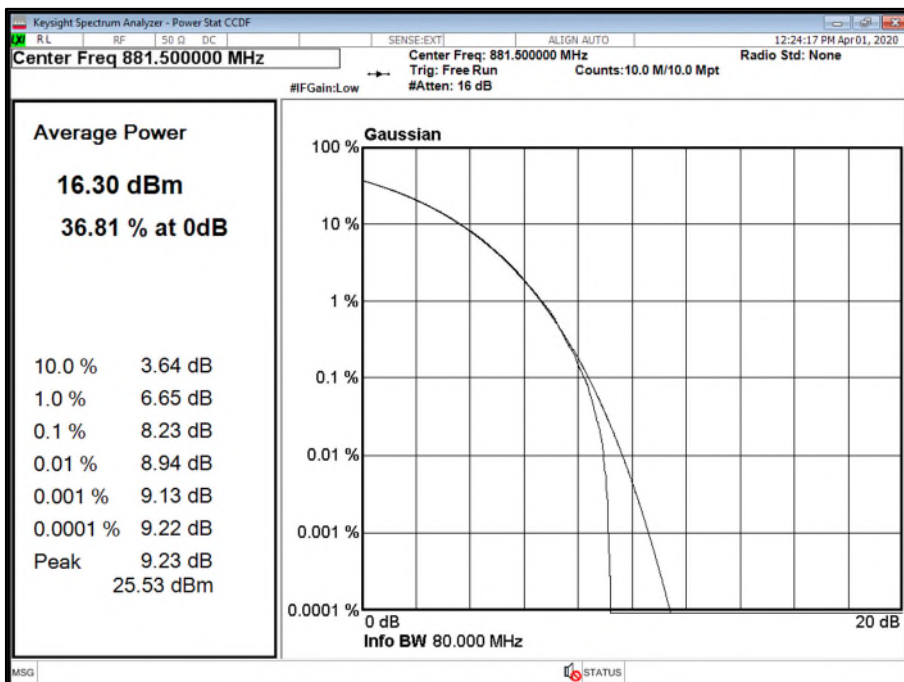



Product Service

Antenna C - NR Modulation QPSK - NR Carrier Bandwidth 20.0 MHz 15 kHz SCS - Channel Position M

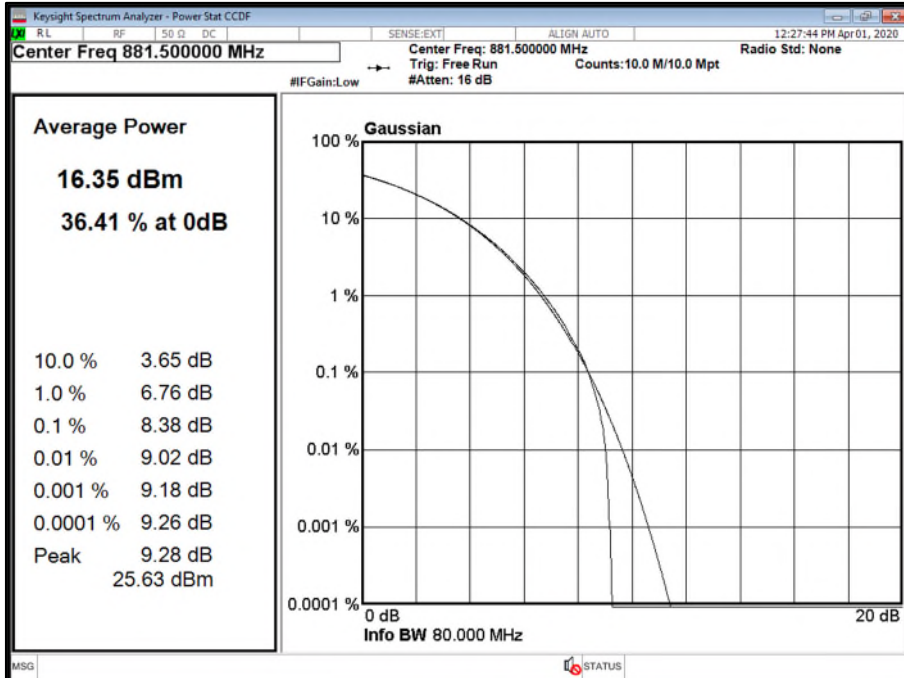

Antenna D - NR Modulation QPSK - NR Carrier Bandwidth 20.0 MHz 15 kHz SCS - Channel Position M

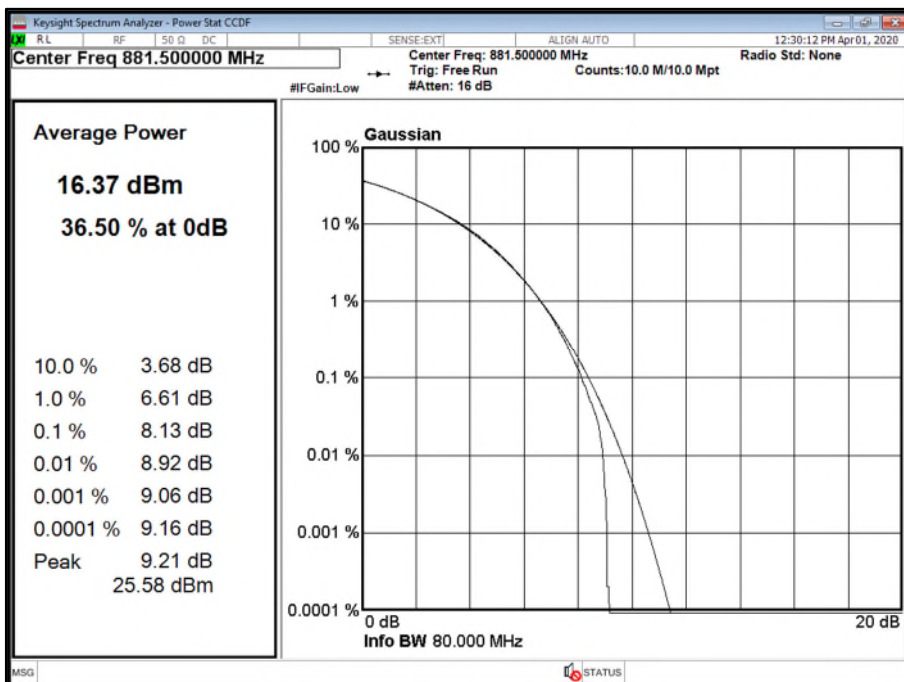



Product Service

Antenna A - NR Modulation QPSK - NR Carrier Bandwidth 5.0 MHz 15 kHz SCS - Channel Position M

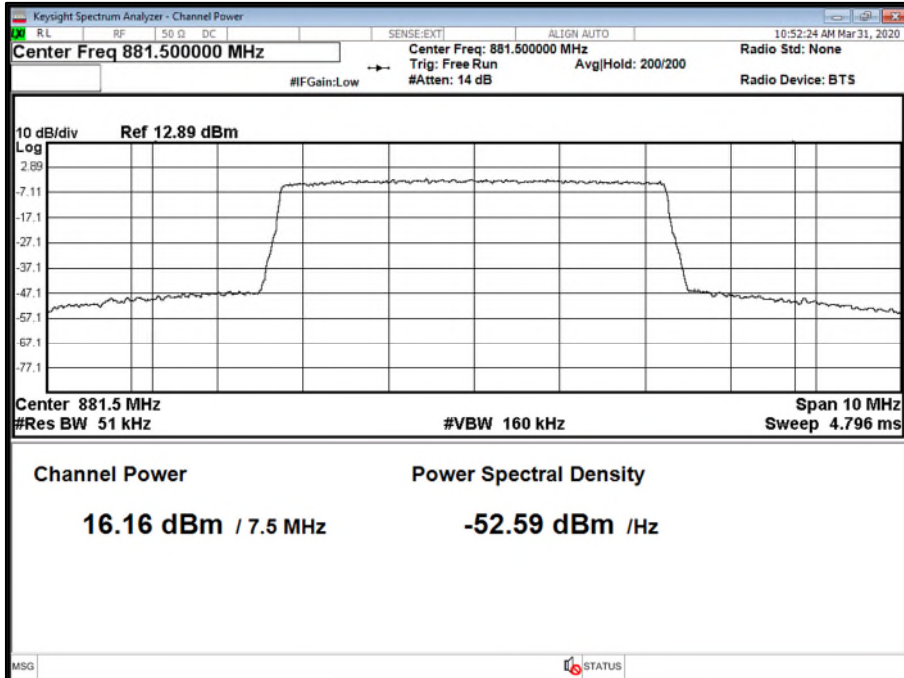

Antenna B - NR Modulation QPSK - NR Carrier Bandwidth 10.0 MHz 15 kHz SCS - Channel Position M

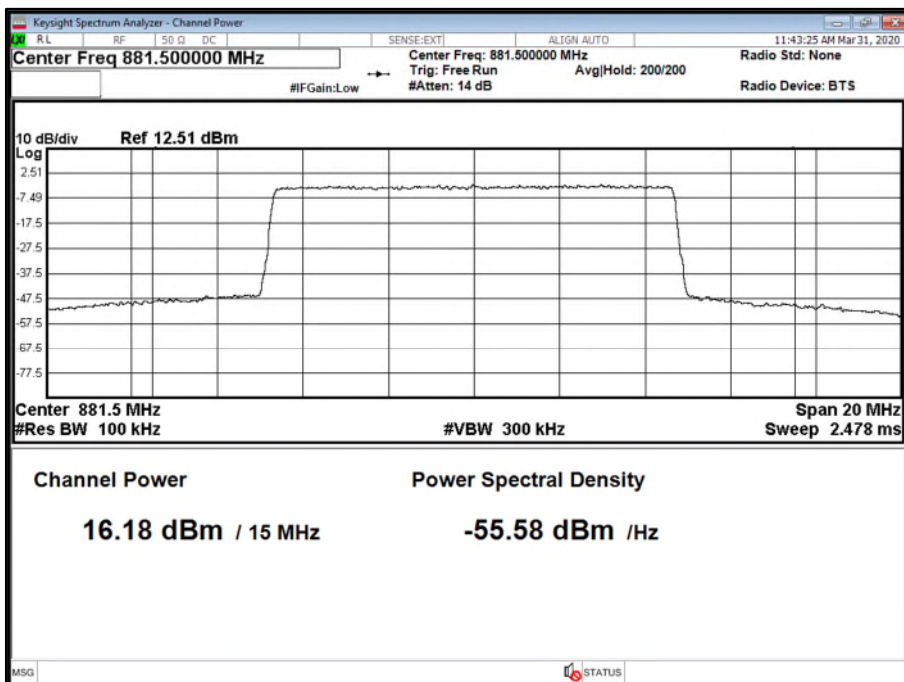



Product Service

Antenna C - NR Modulation QPSK - NR Carrier Bandwidth 15.0 MHz 15 kHz SCS - Channel Position M

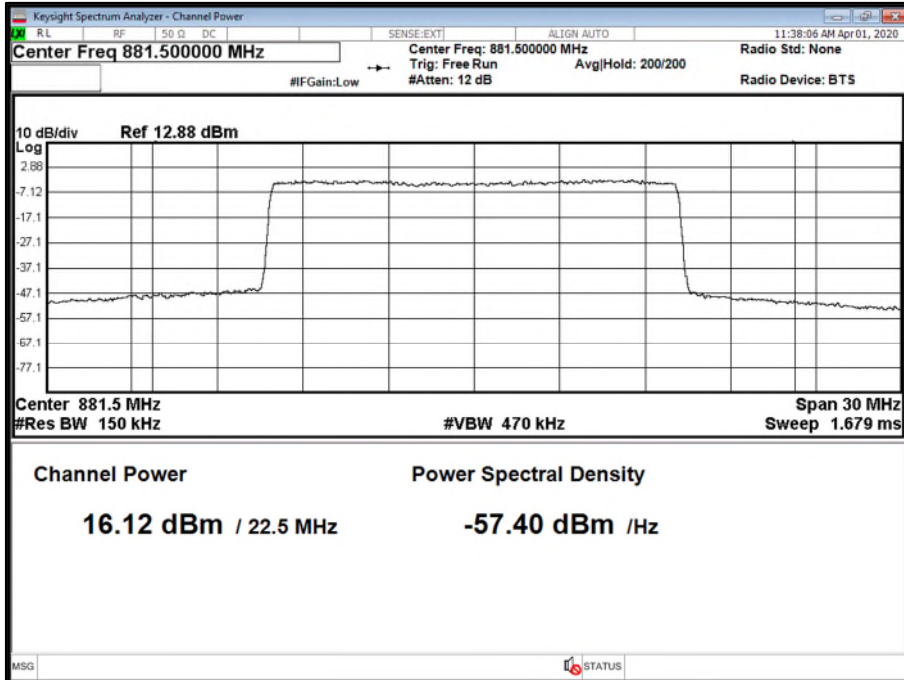

Antenna D - NR Modulation QPSK - NR Carrier Bandwidth 20.0 MHz 15 kHz SCS - Channel Position M

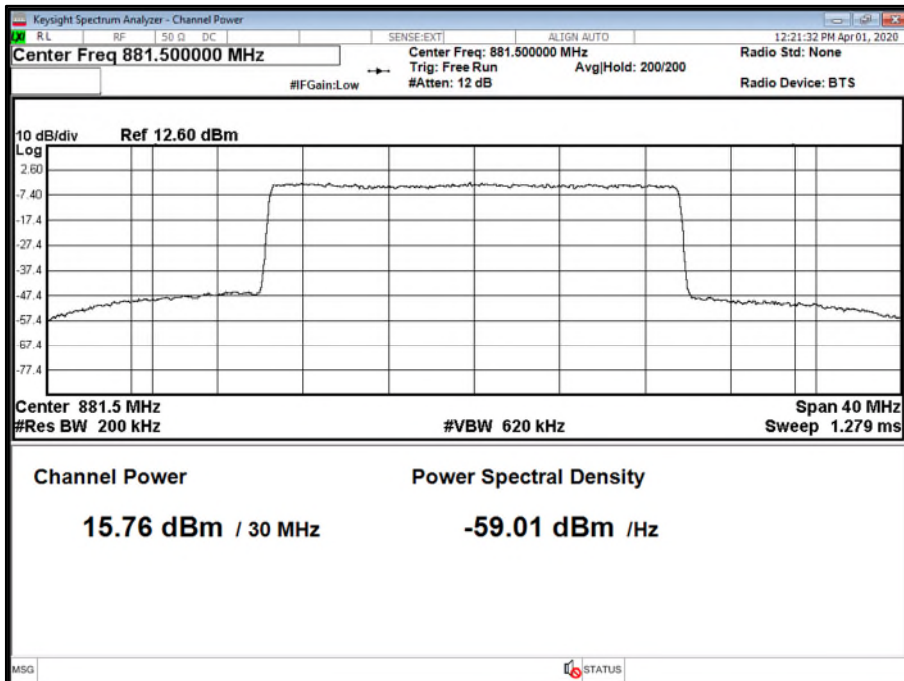



Product Service

Configuration C

Maximum Output Power 17.0 dBm per port

Antenna	NR Modulation	NR Carrier Bandwidth	Peak to Average Ratio (PAR) / Output Power		
			Channel Position T		
			PAR (dB)	Average Power	
dBm	dBm/MHz				
A	QPSK	5.0 MHz 15 kHz SCS	8.99	16.28	10.70
B	QPSK	5.0 MHz 15 kHz SCS	8.99	16.25	10.62
C	QPSK	5.0 MHz 15 kHz SCS	8.99	16.28	10.70
D	QPSK	5.0 MHz 15 kHz SCS	8.86	16.14	10.55
Total			-	22.26	16.66
A	QPSK	10.0 MHz 15 kHz SCS	9.04	15.75	7.46
B	QPSK	10.0 MHz 15 kHz SCS	9.07	15.76	7.36
C	QPSK	10.0 MHz 15 kHz SCS	8.97	15.78	7.34
D	QPSK	10.0 MHz 15 kHz SCS	8.88	16.12	7.63
Total			-	21.88	13.47
A	QPSK	15.0 MHz 15 kHz SCS	9.17	16.26	6.19
B	QPSK	15.0 MHz 15 kHz SCS	9.03	16.11	6.05
C	QPSK	15.0 MHz 15 kHz SCS	9.04	15.71	5.70
D	QPSK	15.0 MHz 15 kHz SCS	8.95	16.00	5.95
Total			-	22.05	12.00
A	QPSK	20.0 MHz 15 kHz SCS	9.13	15.87	4.27
B	QPSK	20.0 MHz 15 kHz SCS	8.94	16.40	4.81
C	QPSK	20.0 MHz 15 kHz SCS	9.03	16.19	4.68
D	QPSK	20.0 MHz 15 kHz SCS	8.91	16.26	4.72
Total			-	22.20	10.65

Remarks

Transmitter port A presented worst case power/typical performance. These results are included for reference.



Product Service

Antenna A - NR Modulation QPSK - NR Carrier Bandwidth 5.0 MHz 15 kHz SCS - Channel Position T

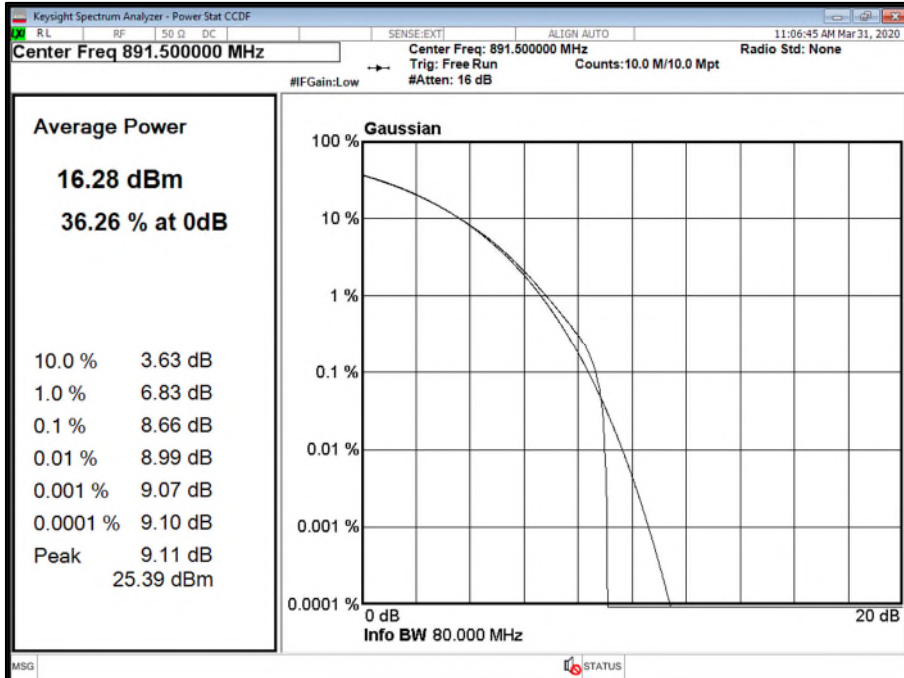

Antenna B - NR Modulation QPSK - NR Carrier Bandwidth 5.0 MHz 15 kHz SCS - Channel Position T

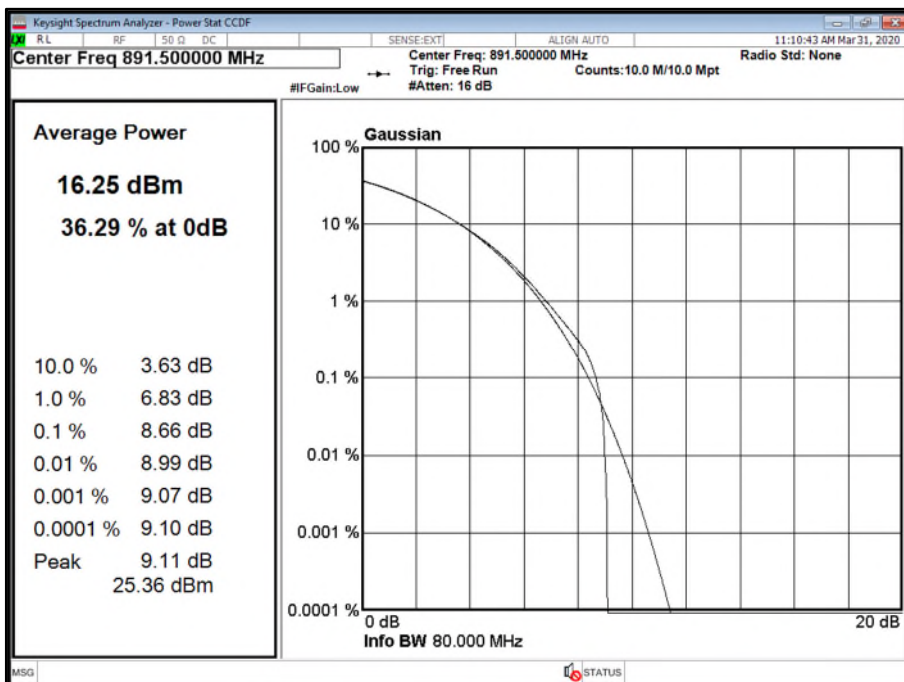



Product Service

Antenna C - NR Modulation QPSK - NR Carrier Bandwidth 5.0 MHz 15 kHz SCS - Channel Position T

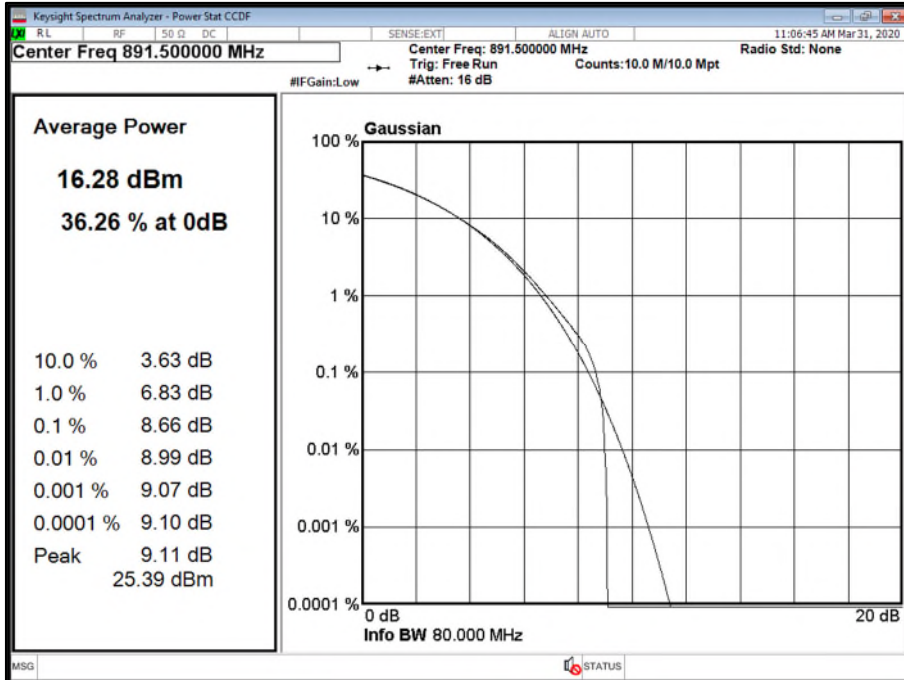

Antenna D - NR Modulation QPSK - NR Carrier Bandwidth 5.0 MHz 15 kHz SCS - Channel Position T

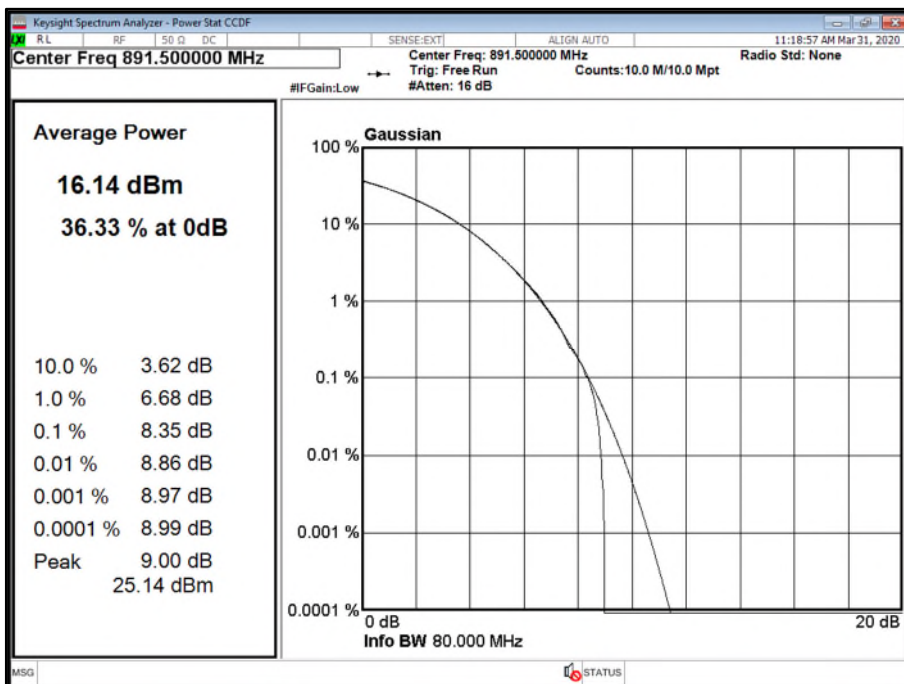



Product Service

Antenna A - NR Modulation QPSK - NR Carrier Bandwidth 10.0 MHz 15 kHz SCS - Channel Position T

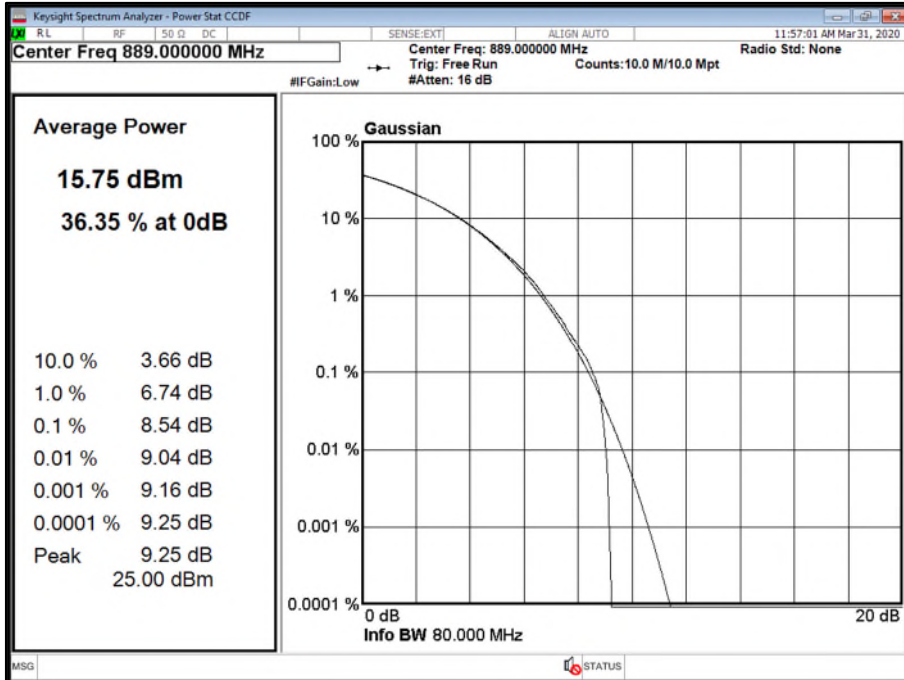

Antenna B - NR Modulation QPSK - NR Carrier Bandwidth 10.0 MHz 15 kHz SCS - Channel Position T

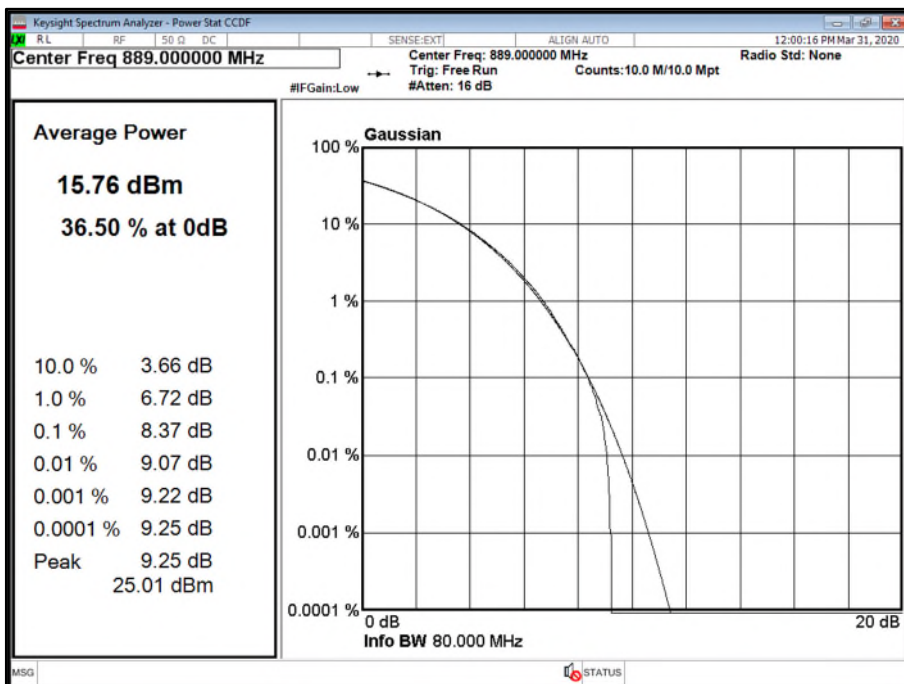



Product Service

Antenna C - NR Modulation QPSK - NR Carrier Bandwidth 10.0 MHz 15 kHz SCS - Channel Position T

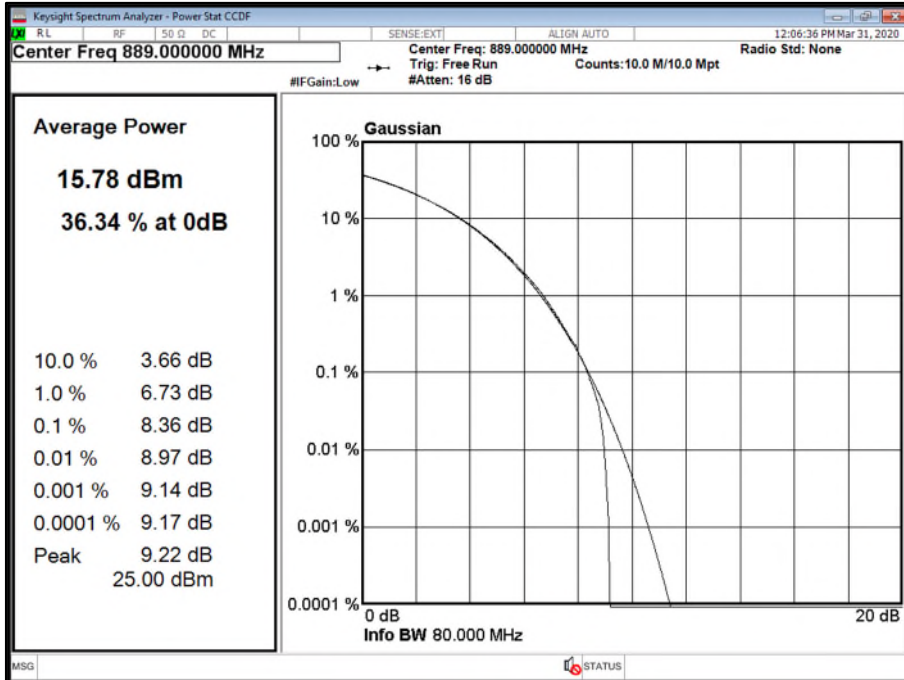

Antenna D - NR Modulation QPSK - NR Carrier Bandwidth 10.0 MHz 15 kHz SCS - Channel Position T

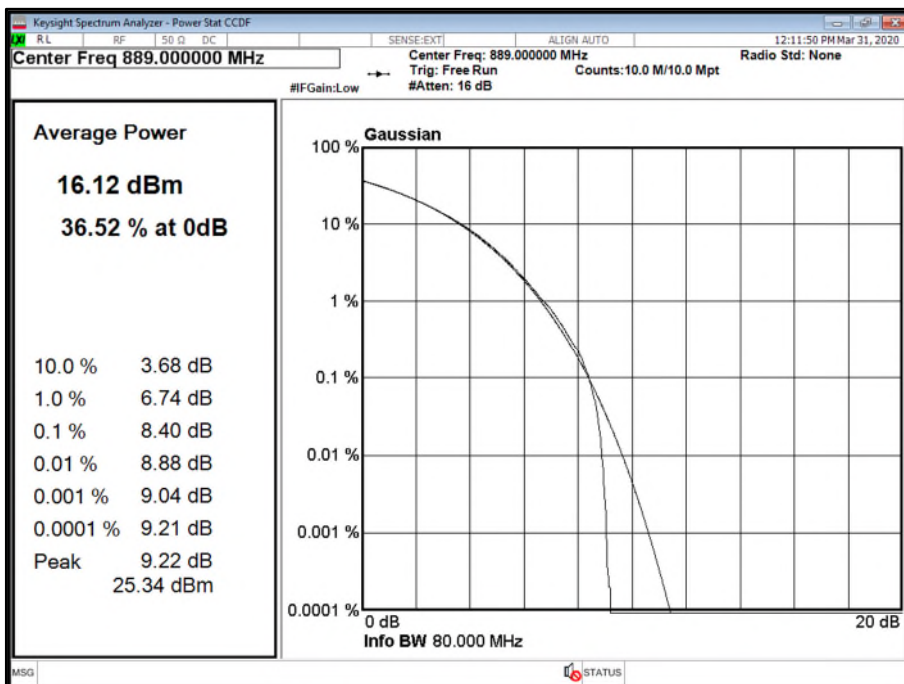



Product Service

Antenna A - NR Modulation QPSK - NR Carrier Bandwidth 15.0 MHz 15 kHz SCS - Channel Position T

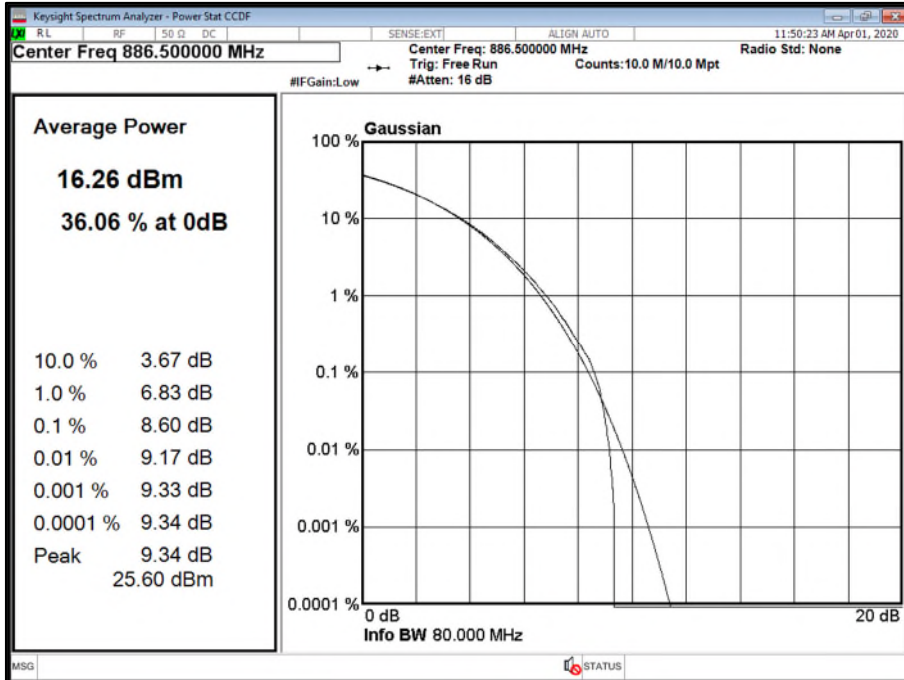

Antenna B - NR Modulation QPSK - NR Carrier Bandwidth 15.0 MHz 15 kHz SCS - Channel Position T

