

Contact person RISE
Tomas Lennhager
Safety and Transport
+46 10 516 54 09
tomas.lennhager@ri.se

Date
2020-05-20

Reference
2P01361-W

Page
1 (111)

Ericsson AB
Anders Karlsson
BURA DURA RP QRM
Torshamnsgatan 21
164 80 Stockholm

Radio measurements on Radio 4499 44B2/B25 44B66A C equipment with FCC ID TA8AKRC161847 and IC 287AB-AS161847

Product name: Radio 4499 44B2/B25 44B66A C
Product number: KRC 161 847/1

RISE Research Institutes of Sweden AB Vehicles and Automation – EMC-IKT

Performed by

Examined by

Tomas Lennhager

Daniel Lundgren

RISE Research Institutes of Sweden AB

Postal address	Office location	Phone / Fax / E-mail
Box 857	Brinellgatan 4	+46 10 516 50 00
SE-501 15 BORÅS	SE-504 62 BORÅS	+46 33 13 55 02
Sweden		info@ri.se

This report may not be reproduced other than in full, except with the prior written approval of the issuing laboratory.

Summary	4
Description of the test object	5
Purpose of test	8
Operation modes during measurements	8
Conducted measurements	8
Radiated measurements.....	8
Test facility	9
References.....	9
Measurement equipment.....	9
Uncertainties	10
Reservation	10
Delivery of test object.....	10
Manufacturer’s representative.....	10
Test engineers	10
Test participant(-s).....	10
Test frequencies used for conducted measurements	11
Test frequencies used for radiated measurements.....	14
Test setup: conducted measurements	15
Test setup: radiated measurements.....	17
RF power output measurements according to CFR 47 §24.232 and §27.50/ RSS-133 6.4, RSS-139 5.5 conducted	18
Test set-up and procedure	18
Results.....	18
Remark.....	21
Limits	21
Occupied bandwidth measurements according to CFR47 2.1049/ RSS-Gen 4.6.1	22
Test set-up and procedure	22
Results.....	22
Band edge measurements according to CFR 47 §24.238 and §27.53/ RSS-133 6.5, RSS-139 6.6.....	30
Test set-up and procedure	30
Results WCDMA	31
Results WCDMA+NB IoT SA	32
Results WCDMA+GSM+NB IoT SA.....	33
Limits	33
Conducted spurious emission measurements according to CFR 47 §24.238 and §27.53(h) / RSS-133 6.5, RSS-139 6.6.....	72
Test set-up and procedure	72
Results WCDMA	73

Results WCDMA+NB IoT SA	74
Results WCDMA+GSM+NB IoT SA.....	74
Remark	75
Limits	75
Field strength of spurious radiation measurements according to CFR 47 §24.238 and §27.53(h) / RSS-133 6.5, RSS-139 6.6.....	101
Measurement equipment	103
Results	103
Limits	103
Frequency stability measurements according to CFR 47 §24.235 and §27.54 / RSS-133 6.3 and IC RSS-139 6.4	106
Test set-up and procedure	106
Results WCDMA	106
Remark	107
Limits	107
Photos of test object	108

Summary

Standard Listed part of		Compliant
FCC CFR 47 part 24 and part 27/ RSS-133, RSS-139, RSS-Gen		
2.1046/ 6.4/ 6.5	RF power output	Yes
2.1049/ 4.6.1 Gen	Occupied bandwidth	Yes
2.1051/ 6.5/ 6.6	Band edge	Yes
2.1051/ 6.5/ 6.6	Spurious emission at antenna terminals	Yes
2.1053/ 6.5/ 6.6	Field strength of spurious radiation	Yes
2.1055/ 6.3/ 6.4	Frequency stability	Yes

Description of the test object

Equipment:	Radio equipment Radio 4499 44B2/B25 44B66A C Product number KRC 161 847/1 FCC ID: TA8AKRC161847 IC: 287AB-AS161847
HVIN:	AS161847
FVIN:	-
Hardware revision state:	R1A
Radio Access Technology, RAT and Frequency range:	Band 2 (B2): Single RAT: W, L, NB IoT SA Multi RAT: G+W+NB IoT SA, G+L+NB IoT SA, W+L+NB IoT SA TX: 1930 – 1990 MHz RX: 1850 – 1910 MHz Band 25 (B25): Single RAT: W, L, NB IoT SA Multi RAT: W+L+NB IoT SA TX: 1930 – 1995 MHz RX: 1850 – 1915 MHz Band 66 (B66): Single RAT: W, L, NB IoT SA Multi RAT: W+L+NB IoT SA TX: 2110 – 2180 MHz RX: 1710 – 1780 MHz
IBW:	B2: 60 MHz B25: 65 MHz B66: 70 MHz
Output power:	Maximum output power per carrier: LTE: 1.4 and 3 MHz: 20 W (1.4 MHz and 3 MHz carriers are not supported in B66) 5 MHz: 40 W 10, 15, 20 MHz: 60 W WCDMA: 40 W GSM: 20 W (only available in B2) NB IoT SA: 20 W Maximum total output power/port: 80 W Maximum total output power/band and port: 60 W

Antenna ports B2/B25:	A-D: 4 TX / 4 RX ports
Antenna ports B66:	A-D: 4 TX / 4 RX ports
Antenna:	No dedicated antenna, handled during licensing.
RF configuration:	<p>Single and multi-carrier, 1-12 carriers per port for both bands(6 in each band), Non-Contiguous Spectrum (NCS), Contiguous Spectrum (CS).</p> <p>LTE: Max 6 carriers per Band and port, TX Diversity, 2x2 MIMO, 4x4 MIMO, Carrier Aggregation (CA) intra-band and inter-band supported.</p> <p>WCDMA: Max 6 carriers per band and port, 2x2 MIMO, 4x4 MIMO.</p> <p>GSM: Max 4 carriers per port, Single antenna, dual TX and Quad RX.</p> <p>NB IoT SA: Max 2 carriers per band and port.</p> <p>NB IoT Guard Band (GB): Max 1 Anchor PRB + 1 Non-Anchor PRB (For 10 MHz LTE carriers and wider).</p> <p>NB IoT Inband (IB): Max 1 Anchor PRB + 1 Non-Anchor PRB (For 3 MHz LTE carriers and wider).</p>
Channel bandwidths:	<p>LTE: 1.4 MHz, 3MHz, 5 MHz, 10 MHz 15 MHz and 20 MHz</p> <p>WCDMA: 5 MHz</p> <p>GSM: 200 kHz</p> <p>NB IoT: 200 kHz</p>
Modulations:	<p>LTE: QPSK, 16QAM, 64QAM and 256QAM</p> <p>WCDMA: QPSK, 16QAM and 64QAM</p> <p>GSM: GMSK, AQPSK and 8-PSK</p> <p>NB IoT SA/ GB/ IB: QPSK, BPSK (BPSK is for up link only)</p>

Emission designators:	LTE with and without NB IoT IB:	1.4 MHz BW: 1M10W7D 3 MHz BW: 2M69W7D 5 MHz BW: 4M48W7D 10 MHz BW: 8M97W7D 15 MHz BW: 13M5W7D 20 MHz BW: 17M9W7D 40 MHz BW: 37M8W7D (2x20 MHz, Carrier Aggregation)
	WCDMA:	4M18F9W
	GSM:	GMSK: 245KGXW AQPSK: 241KGXW 8PSK: 245KG7W
	NB IoT SA:	200KW7D
	LTE with NB IoT GB:	10 MHz BW: 9M39W7D 15 MHz BW: 14M0W7D 20 MHz BW: 18M4W7D
RF power Tolerance:		+0.6/ -2.5 dB
CPRI Speed		Up to 10.1 Gbit/s
Nominal supply voltage:		-48VDC

The information above is supplied by the manufacturer.

Tested configuration: Single RAT: WCDMA
 Multi RAT: WCDMA+ GSM+ NB IoT SA

Purpose of test

The purpose of the tests is to verify compliance to the performance characteristics specified in applicable items of FCC CFR 47 part 24 and Part 27, ISSED RSS-133, RSS-139 and RSS-Gen.

Operation modes during measurements

Measurements were performed with the test object transmitting the Test model 1 which are defined in 3GPP TS 25.141. Test model 1 (TM1) represent QPSK modulation. Test model 5 (TM5) includes the 16QAM modulation and Test model 6 (TM6) includes the 64QAM modulation.

GSM

Measurements were performed with the test object transmitting following modulations: GMSK, AQPSK and 8-PSK.

NB IoT SA (Stand Alone)

NB IoT SA measurements were performed with the test object transmitting test model N-TM representing QPSK as defined in 3GPP TS 36.141.

B2 and B25 overlap each other. They both have the same lower edge but the upper edge for B25 is 5 MHz higher. For measurements on middle configuration, the middle frequency for B25 was deemed representative for both bands. For band edge measurements on the top frequency configuration the measurements were repeated for the upper edge of both B2 and B25.

For all measurements the radio was configured with the total output power of 80 watts per port. For measurements noted with B25 max power configuration the Carrier(s) were configured with the maximum possible output power for the Carrier(s) in that band. The carrier in B66 was a 5 MHz WCDMA carrier on 2145 MHz configured with the necessary output power to reach the maximum total power per port of 80 watts.

For measurements noted with B66 max power configuration, the Carrier(s) were configured with the maximum possible output power for the Carrier(s) in that band. The carrier in B2/25 was a 5 MHz WCDMA carrier on 1962.5 MHz configured with the necessary output power to reach the maximum total power per port of 80 watts.

For single RAT, single Carrier measurements it merely denotes to which Band the measurement is pertaining, since the carriers in both Bands were configured with 40 watts output power.

Conducted measurements

The test object was supplied with -48 VDC by an external power supply. Additional connections are documented in the set-up drawings for conducted measurements.

Radiated measurements

The test object was powered with -48 VDC by an external power supply. Additional connections are documented in the set-up drawings for radiated measurements.

Test facility

The used semi-anechoic chamber is compliant with ANSI C63.4. RISE is an ISO 17025 accredited test facility for Electromagnetic Compatibility (EMC) and Radio testing. RISE is a Recognized Lab under FCC and ISED (registration No. 3482A) rules for the scope of standards used in this test report.

References

Measurements were done according to relevant parts of the following standards:

ANSI C63.4-2014
 CFR 47 part 2, March 2020
 CFR 47 part 24, March 2020
 CFR 47 part 27, March 2020
 ANSI C63.26-2015
 KDB 971168 D03 IM Emission Repeater Amp v01
 3GPP TS 36.141, version 15.3.0
 3GPP TS 25.141, version 15.3.0
 RSS-Gen Issue 5 Amendment 1
 RSS-133 Issue 6 Amendment 1
 RSS-139 Issue 3

Measurement equipment

	Calibration Due	RISE number
Test site Tesla	2022-12	503 881
Test site Marconi	-	15:121
R&S ESU 40	2021-01	901 385
R&S FSQ 40	2020-07	504 143
R&S FSW 43	2020-09	902 073
Control computer with R&S software EMC32 version 10.20.01	-	BX62351
Directional coupler	2021-02	901 496
RF attenuator	2021-02	902 282
High pass filter 3-27 GHz	2021-02	901 502
High pass filter 3-27 GHz	2021-02	BX40074
Coaxial cable Megaphase	2021-02	BX50191
Coaxial cable Sucoflex 102EA	2021-02	BX50236
Coaxial cable Sucoflex 102EA	2021-02	BX50237
Coaxial cable, Tesla emission	2020-06	BX91490
Coaxial cable	2020-09	503 508
Coaxial cable	2020-09	503 509
Teseq BiConiLog Antenna CBL6143A	2022-09	BX92331
EMCO Horn Antenna 3115	2021-07	502 175
Flann Standard Gain Horn 20240-20	-	BX92412
Miteq, Low Noise Amplifier	2021-01	503 278
µComp Nordic, Low Noise Amplifier	2021-01	901 545
Temperature and humidity meter, Testo 635	2020-06	504 203
Temperature and humidity meter, Testo 625	2020-06	504 188

Uncertainties

Measurement and test instrument uncertainties are described in the quality assurance documentation "SP-QD 10885". The uncertainties are calculated with a coverage factor $k=2$ (95% level of confidence).

Compliance evaluation is based on a shared risk principle with respect to the measurement uncertainty.

Reservation

The test results in this report apply only to the particular test object as declared in the report.

Delivery of test object

The test object was delivered: 2020-02-10.

Manufacturer's representative

Mikael Jansson, Ericsson AB.

Test engineers

Tomas Isbring and Andreas Björnqvist for radiated tests, RISE
Tomas Lennhager and Karl Flysjö for conducted tests, RISE.

Test participant(-s)

None.

Test frequencies used for conducted measurements

B25 WCDMA:

Frequency [MHz]	Symbolic name	Comment
1932.4	B	TX bottom frequency, 46 dBm output power
1962.4	M	TX middle frequency, 46 dBm output power
1992.6	T	TX top frequency, 46 dBm output power
1950.0 1955.0 1960.0 1965.0 1970.0 1975.0	M6	TX max carrier constellation, 40 dBm output power per carrier (47.8 dBm total output power).
1932.4 1937.4 1992.6	Bim	TX constellation for Bim, 43 dBm output power per carrier (47.8 dBm total output power).
1932.4 1987.6 1992.6	Tim	TX constellation for Tim, 43 dBm output power per carrier (47.8 dBm total output power).

B2 WCDMA:

Frequency [MHz]	Symbolic name	Comment
1987.6	T	TX top frequency, 46 dBm output power

The RX frequency was configured 80 MHz below the corresponding TX frequency according to the applicable duplex offset for the operating band.

B66 WCDMA:

Frequency [MHz]	Symbolic name	Comment
2112.4	B	TX bottom frequency, 46 dBm output power
2145.0	M	TX middle frequency, 46 dBm output power
2177.6	T	TX top frequency, 46 dBm output power
2132.4 2137.4 2142.4 2147.4 2152.4 2157.4	M6	TX max carrier constellation, 40 dBm output power per carrier (47.8 dBm total output power).
2112.4 2117.4 2177.6	Bim	TX constellation for Bim, 43 dBm output power per carrier (47.8 dBm total output power).
2112.4 2172.6 2177.6	Tim	TX constellation for Tim, 43 dBm output power per carrier (47.8 dBm total output power).

All RX frequencies were configured 400MHz below the corresponding TX frequency according the applicable duplex offset for the operating band.

B2 GSM+WCDMA:

Frequency [MHz]	Symbolic name	Comment
G ₁ =1958.2 G ₂ =1958.8 G ₃ =1959.4 G ₄ =1960.0 W=1945.0	M _{4G+W}	TX mid Frequencies for max GSM carriers and a WCDMA Carrier. 40.8 dBm output power per carrier (47.8 dBm total output power).
G ₁ =1930.4 G ₂ =1931.0 W=1987.6	Bim _{G+W}	TX constellation for Bim, 43 dBm output power per carrier (47.8 dBm total output power).
G ₁ =1989.0 G ₂ =1989.6 W=1932.4	Tim _{G+W}	TX constellation for Tim, 43 dBm output power per carrier (47.8 dBm total output power).

B2 NB IoT SA+GSM+WCDMA:

Frequency [MHz]	Symbolic name	Comment
G=1930.4 IoT=1931.0 W=1987.6	Bim _{G+IoT+W}	TX constellation for Bim, 43 dBm output power per carrier (47.8 dBm total output power).
W=1932.4 IoT=1989.0 G=1989.6	Tim _{G+IoT+W}	TX constellation for Tim, 43 dBm output power per carrier (47.8 dBm total output power).
W ₁ =1932.4 G ₁ =1950.2 IoT ₁ =1950.8 G ₂ =1969.2 IoT ₂ =1969.8 W ₂ =1987.6	Max _{G+IoT+W}	TX max carrier constellation, 40 dBm output power per carrier (47.8 dBm total output power).

B25 NB IoT SA+WCDMA

Frequency [MHz]	Symbolic name	Comment
IoT ₁ =1930.2 IoT ₂ =1930.8 W=1992.6	Bim _{IoT+W}	TX constellation for Bim, 43 dBm output power per carrier (47.8 dBm total output power).
IoT ₁ =1994.8 IoT ₂ =1994.2 W=1932.4	Tim _{IoT+W}	TX constellation for Tim, 43 dBm output power per carrier (47.8 dBm total output power).

The RX frequency was configured 80 MHz below the corresponding TX frequency according to the applicable duplex offset for the operating band.

B66 NB IoT SA+WCDMA

Frequency [MHz]	Symbolic name	Comment
IoT ₁ =2110.2 IoT ₂ =2110.8 W=2177.6	Bim _{IoT+W}	TX constellation for Bim, 43 dBm output power per carrier (47.8 dBm total output power).
IoT ₁ =2179.8 IoT ₂ =2179.2 W=2112.4	Tim _{IoT+W}	TX constellation for Tim, 43 dBm output power per carrier (47.8 dBm total output power).

All RX frequencies were configured 400 MHz below the corresponding TX frequency according to the applicable duplex offset for the operating band.

Test frequencies used for radiated measurements

B2/25 and B66

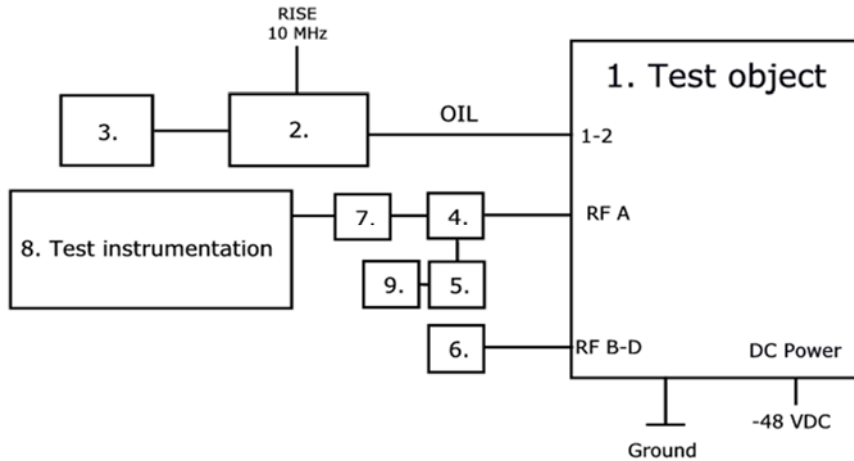
Frequency [MHz]	Symbolic name	Comment
1932.4	B	TX bottom frequency
1962.6	M	TX middle frequency
1992.6	T	TX top frequency
1967.6 1772.6 1977.6 1982.6 1987.6 1992.6	T6	TX max carrier constellation
1932.4 1937.4 2177.6	Bim _w	3-carriers TX constellation
1932.4 2172.6 2177.6	Tim _w	3-carriers TX constellation
W=1984.6 G=1989.6 G=1989.0	Tim _{w+G}	3-carriers TX constellation
2112.4	B	TX bottom frequency
2145	M	TX middle frequency
2177.6	T	TX top frequency
2157.6 2162.6 2167.6 2172.6 2177.6	T6	TX max carrier constellation

For B2/25 the RX frequency was configured 80 MHz below the corresponding TX frequency according to the applicable duplex offset for the operating band.

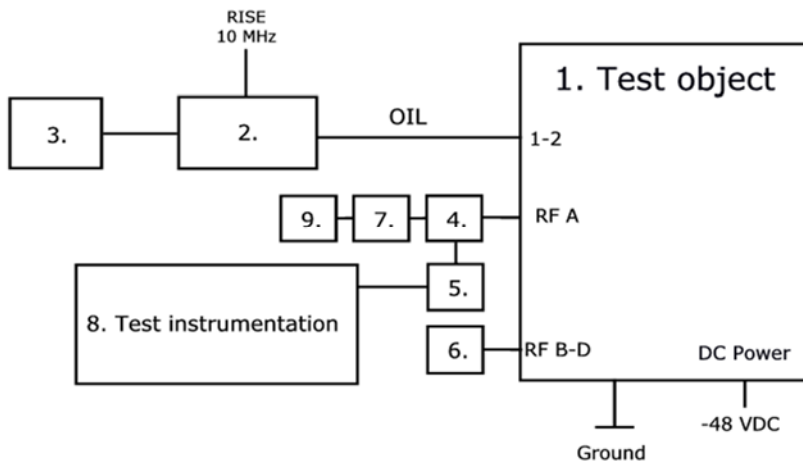
For B66 the RX frequencies were configured 400 MHz below the corresponding TX frequency according to the applicable duplex offset for the operating band.

Test setup: conducted measurements

Setup for measurements from 9 kHz to 3 GHz.



Setup for measurements from 3 GHz to 22GHz.



Test object:

1.	Radio 4499 44B2/B25 44B66A C, KRC 161 847/1, rev. R1A, s/n: E23B067325 With Radio Software: CXP 901 3268/15, rev. R81JH09 FCC ID: TA8AKRC161847, IC: 287AB-AS161847
----	---------------------------------------------------------------------------------------------------------------------------------------------------------------------------

Associated equipment:

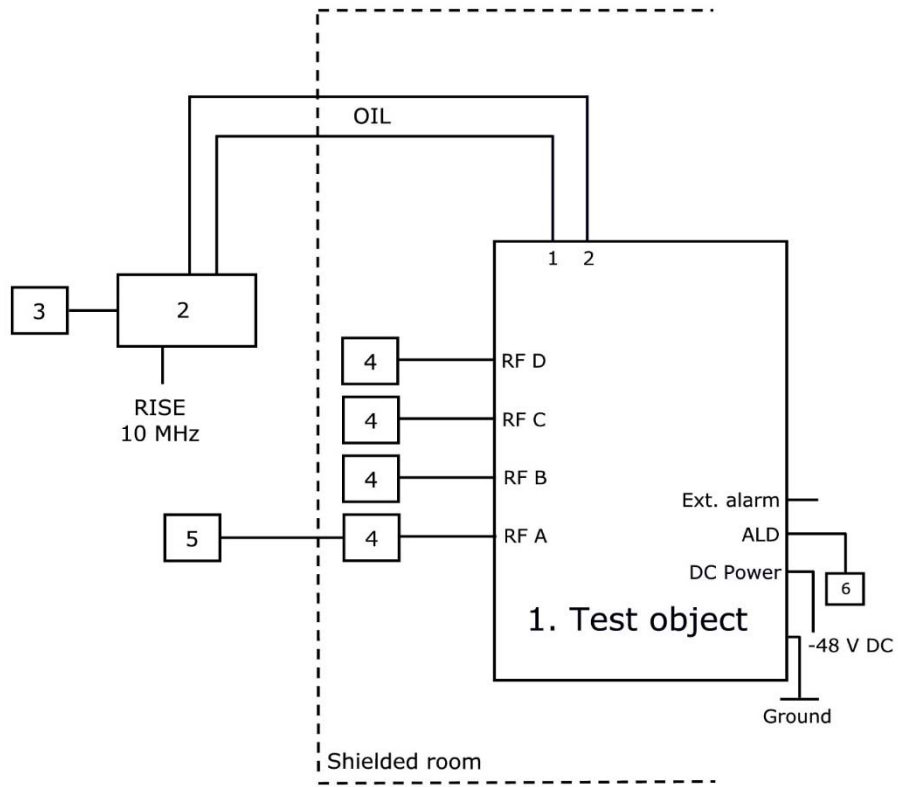
2.	Testing Equipment: CT10, LPC 102 487/1, rev. R1C, s/n: T01F265039, BAMS – 1001908401 with software CXC 173 5312/29, rev. R1A02
----	--------------------------------------------------------------------------------------------------------------------------------------

Functional test equipment:

3.	Computer, HP ZBook 15u G3, BAMS - 1001835579
4.	Directional Coupler: RISE-number: 901 496
5.	High pass filter 3-27 GHz: RISE-Number: 901 502
6.	50 ohm terminator on each port

7.	RF Attenuator: RISE number: 902 282
8.	RISE Test Instrumentation according to measurement equipment list for each test. The signal analyzer was connected to the RISE 10 MHz reference standard during all measurements.
9.	50 ohm SMA terminator.

Test setup: radiated measurements



1.	Radio 4499 44B2/B25 B66A C, KRC 161 847/1, rev. R1A, s/n: E23B067329 With Radio Software: CXP 901 3268/15, rev. R81JH09. FCC ID: TA8AKRC161847, IC: 287AB-AS161847
----	--------------------------------------------------------------------------------------------------------------------------------------------------------------------------

Associated equipment:

2.	Testing Equipment: CT10, LPC 102 487/1, rev. R1C, s/n: T01F265031, BAMS – 1000797753 with software CXC 173 5312/25, rev. R1A07
----	--------------------------------------------------------------------------------------------------------------------------------------

Functional test equipment:

3.	HP EliteBook 8560w, BAMS – 1001236854
4.	Attenuator/ Terminator
5.	R&S ESIB 26, SP no: 503 292 for supervision purpose only
6.	Remote Control Unit, ANDREW Model: ATM200-A20, Serial: CN10151085133

Interfaces:

Power input configuration DC: -48 VDC	Power
RF A-D, 4.3-10 connector, combined TX/RX	Antenna
1, Optical Interface Link, single mode opto fibre	Signal
2, Optical Interface Link, single mode opto fibre	Signal
ALD Control, shielded multi-wire	Signal
EXT Alarm, shielded multi-wire	Signal
Ground wire	Ground

RF power output measurements according to CFR 47 §24.232 and §27.50/ RSS-133 6.4, RSS-139 5.5 conducted

Date	Temperature	Humidity
2020-04-03	24 °C ± 3 °C	16 % ± 5 %
2020-04-14	22 °C ± 3 °C	10 % ± 5 %

Test set-up and procedure

The measurements were made per definition in ANSI C63.26, 5.2.3.4. The test object was connected to a signal analyser measuring peak and RMS output power in CDF mode. A resolution bandwidth of 80 MHz was used if not otherwise.

Measurement equipment	RISE number
R&S FSW 43	902 073
Directional coupler	901 496
RF attenuator	902 282
Coaxial cable Megaphase	BX50191
Coaxial cable Sucoflex 102EA	BX50237
Testo 635, temperature and humidity meter	504 203

Measurement uncertainty: 1.1 dB

Results

B25 max power configuration:

Single carrier TM1

Rated output power level at each RF port 1x 46 dBm/ port.

Symbolic name	Output power CCDF [RMS dBm/ PAR dB]				
	Port RF A	Port RF B	Port RF C	Port RF D	Total power ¹⁾
B	45.42/ 7.38	45.43/7.38	45.25/7.38	45.38/7.38	51.39
M	45.35/ 7.32	45.38/7.34	45.24/7.32	45.30/7.34	51.34
T	45.51/ 7.36	45.50/7.36	45.36/7.36	45.39/7.38	51.46

¹⁾: summed output power according to ANSI C63.26 5.2.5.3 and 6.4.3.2.3.

Note: The PAR value is the 0.1 % Peak to Average Ratio.

Rated output power level at each RF port 1x 46 dBm/ port.

	Output power per 1 MHz [RMS dBm]				
Symbolic name	Port RF A	Port RF B	Port RF C	Port RF D	Total power ¹⁾
T	40.00	40.03	39.87	39.89	45.97

¹⁾: summed output power according to ANSI C63.26 5.2.5.3 and 6.4.3.2.3.

Single carrier TM5

Rated output power level at each RF port 1x 46 dBm/ port.

	Output power CCDF [RMS dBm/ PAR dB]				
Symbolic name	Port RF A	Port RF B	Port RF C	Port RF D	Total power ¹⁾
T	45.47/7.36	45.49/7.34	45.38/7.34	45.37/7.36	51.45

Single carrier TM6

Rated output power level at each RF port 1x 46 dBm/ port.

	Output power CCDF [RMS dBm/ PAR dB]				
Symbolic name	Port RF A	Port RF B	Port RF C	Port RF D	Total power ¹⁾
T	45.48/7.34	45.49/7.34	45.37/7.34	45.40/7.36	51.46

Multi carrier TM1

Rated output power level at each RF port 6x 40 dBm (47.8 dBm total power)/ port.

	Output power CCDF [RMS dBm/ PAR dB]				
Symbolic name	Port RF A	Port RF B	Port RF C	Port RF D	Total power ¹⁾
M6	47.26/7.16	47.20/7.16	47.20/7.16	47.20/7.16	53.24

¹⁾: summed output power according to ANSI C63.26 5.2.5.3 and 6.4.3.2.3.

Note: The PAR value is the 0.1 % Peak to Average Ratio.

B66 max power configuration:

Single carrier TM1

Rated output power level at each RF port 1x 46 dBm/ port.

	Output power CCDF [RMS dBm/ PAR dB]				
Symbolic name	Port RF A	Port RF B	Port RF C	Port RF D	Total power ¹⁾
B	45.62/7.38	45.76/7.36	45.66/7.36	45.63/7.36	51.69
M	45.37/7.32	45.47/7.32	45.46/7.34	45.50/7.34	51.47
T	45.39/7.36	45.50/7.36	45.41/7.38	45.45/7.36	51.46

¹⁾: summed output power according to ANSI C63.26 5.2.5.3 and 6.4.3.2.3.

Note: The PAR value is the 0.1 % Peak to Average Ratio.

Rated output power level at each RF port 1x 46 dBm/ port.

	Output power per 1 MHz [RMS dBm]				
Symbolic name	Port RF A	Port RF B	Port RF C	Port RF D	Total power ¹⁾
B	40.11	40.22	40.16	40.13	46.18

¹⁾: summed output power according to ANSI C63.26 5.2.5.3 and 6.4.3.2.3.

Single carrier TM5

Rated output power level at each RF port 1x 46 dBm/ port.

	Output power CCDF [RMS dBm/ PAR dB]				
Symbolic name	Port RF A	Port RF B	Port RF C	Port RF D	Total power ¹⁾
B	45.59/7.36	45.73/7.36	45.68/7.34	45.63/7.34	51.68

Single carrier TM6

Rated output power level at each RF port 1x 46 dBm/ port.

	Output power CCDF [RMS dBm/ PAR dB]				
Symbolic name	Port RF A	Port RF B	Port RF C	Port RF D	Total power ¹⁾
B	45.63/7.36	45.75/7.34	45.69/7.36	45.63/7.36	51.70

Multi carrier TM1

Rated output power level at each RF port 6x 40 dBm (47.8 dBm total power)/ port.

	Output power CCDF [RMS dBm/ PAR dB]				
Symbolic name	Port RF A	Port RF B	Port RF C	Port RF D	Total power ¹⁾
M6	47.33/7.12	47.37/7.12	47.31/7.12	47.33/7.12	53.36

¹⁾: summed output power according to ANSI C63.26 5.2.5.3 and 6.4.3.2.3.

Note: The PAR value is the 0.1 % Peak to Average Ratio.

Remark

ERP/EIRP compliance is addressed at the time of licensing, as required by the responsible FCC/ISED Bureau(s). Licensee's are required to take into account maximum antenna gain used in combination with above power settings to prevent the radiated output power to exceed the limits.

Limits

§24.232 and RSS-133 6.4

The maximum output power may not exceed 3280 W/MHz (EIRP).

In measuring transmissions in this band using an average power technique, the peak-to-average ratio (PAR) of the transmission may not exceed 13 dB.

§27.50 (d) an RSS-139 6.5

The maximum output power may not exceed 3280 W/MHz (EIRP).

In measuring transmissions in this band using an average power technique, the peak-to-average ratio (PAR) of the transmission may not exceed 13 dB.

Complies?	Yes
-----------	-----

Occupied bandwidth measurements according to CFR47 2.1049/ RSS-Gen 4.6.1

Date	Temperature	Humidity
2020-04-03	24 °C ± 3 °C	16 % ± 5 %
2020-04-08	22 °C ± 3 °C	15 % ± 5 %
2020-04-09	22 °C ± 3 °C	13 % ± 5 %

Test set-up and procedure

The measurements were made per definition in ANSI C63.26, 5.4.4. The output was connected to a signal analyzer with the Peak detector activated in max hold.

Measurement equipment	RISE number
R&S FSW 43	902 073
Directional coupler	901 496
RF attenuator	902 282
Coaxial cable Megaphase	BX50191
Coaxial cable Sucoflex 102EA	BX50237
Testo 635, temperature and humidity meter	504 203

Measurement uncertainty: 3.7 dB

Results

B2/25 max power configuration:

Single carrier TM1

Diagram	Symbolic name	Tested Port	Occupied BW (99%) [MHz]
1.1	B	RF A	4.184
1.2	M	RF A	4.180
1.3	M	RF B	4.173
1.4	M	RF C	4.175
1.5	M	RF D	4.181
1.6	T	RF A	4.180

Single carrier TM5

Diagram	Symbolic name	Tested Port	Occupied BW (99%) [MHz]
1.7	M	RF A	4.167

Single carrier TM6

Diagram	Symbolic name	Tested Port	Occupied BW (99%) [MHz]
1.8	M	RF A	4.155

B66 max power configuration:

Single carrier TM1

Diagram	Symbolic name	Tested Port	Occupied BW (99%) [MHz]
1.9	B	RF B	4.183
1.10	M	RF A	4.182
1.11	M	RF B	4.184
1.12	M	RF C	4.184
1.13	M	RF D	4.176
1.14	T	RF B	4.184

Single carrier TM5

Diagram	Symbolic name	Tested Port	Occupied BW (99%) [MHz]
1.15	M	RF B	4.183

Single carrier TM6

Diagram	Symbolic name	Tested Port	Occupied BW (99%) [MHz]
1.16	M	RF B	4.154

Diagram 1.1, TM1, B, Port A:

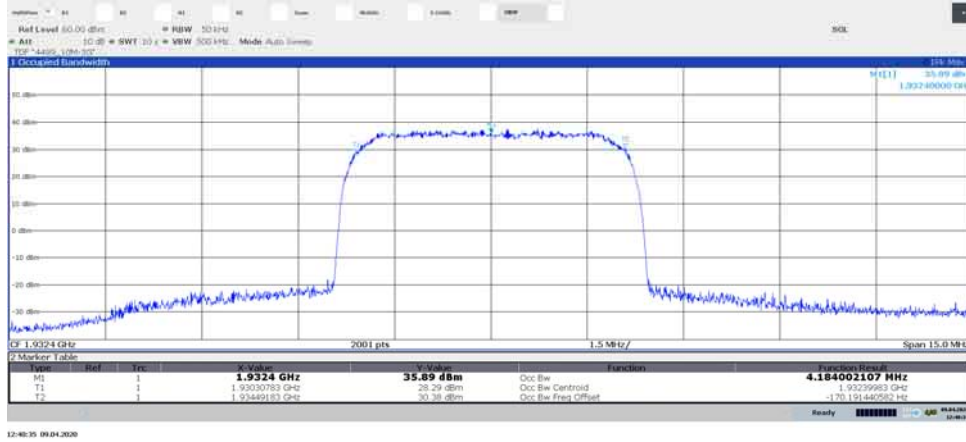


Diagram 1.2, TM1, M, Port A:

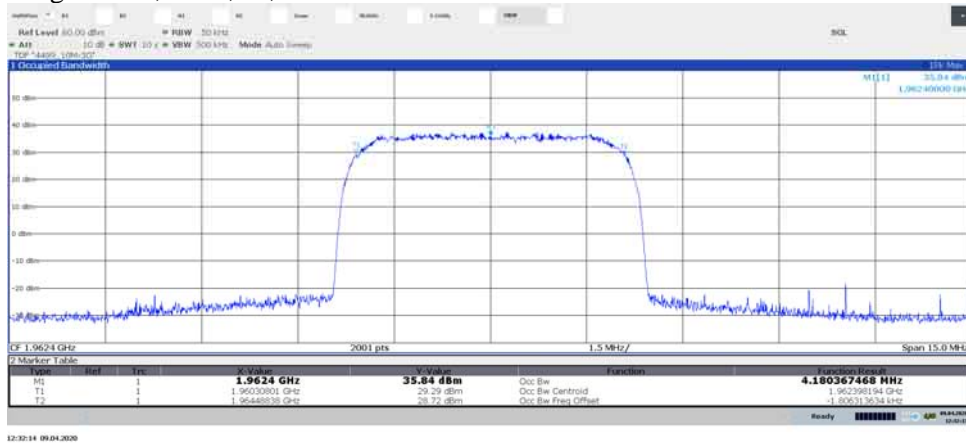


Diagram 1.3, TM1, M, Port B:

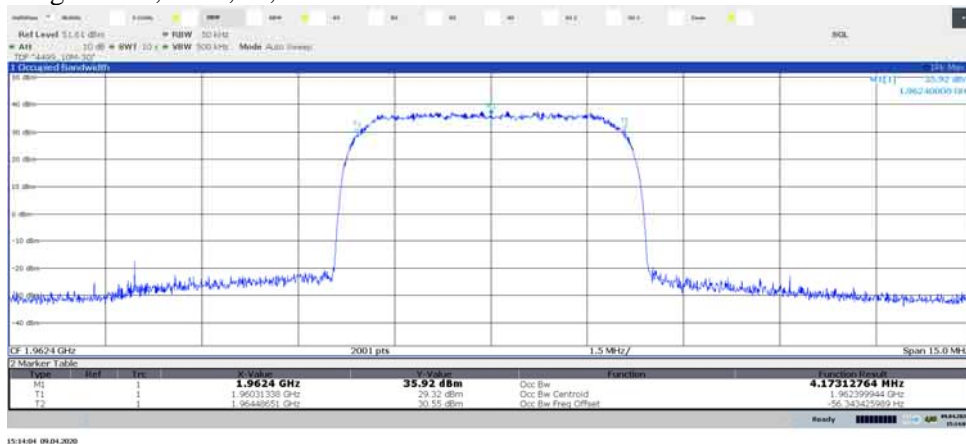


Diagram 1.4, TM1, M, Port C:

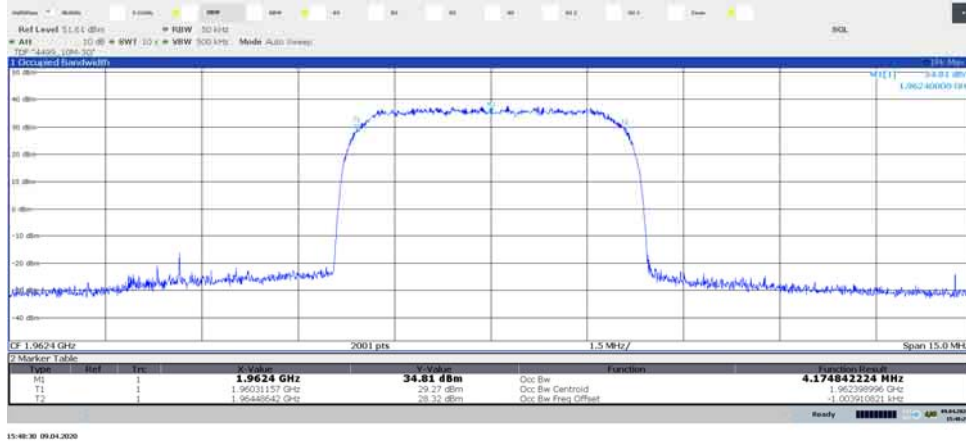


Diagram 1.5, TM1, M, Port D:

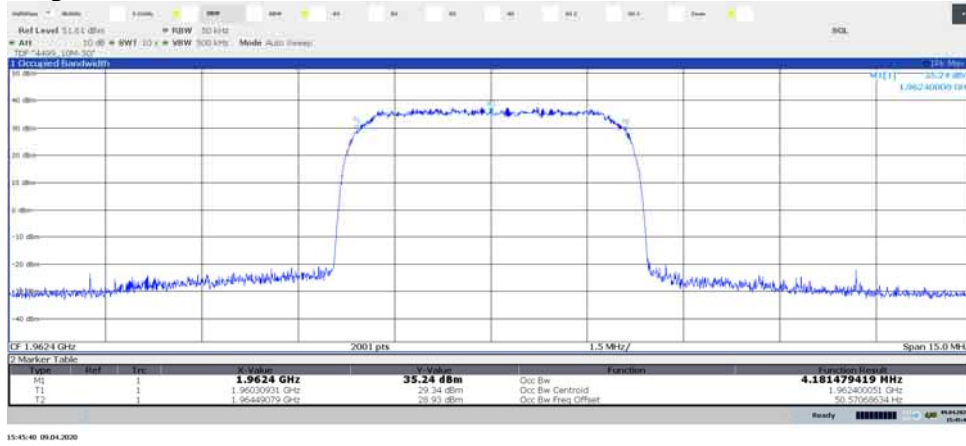


Diagram 1.6, TM1, T, Port B:

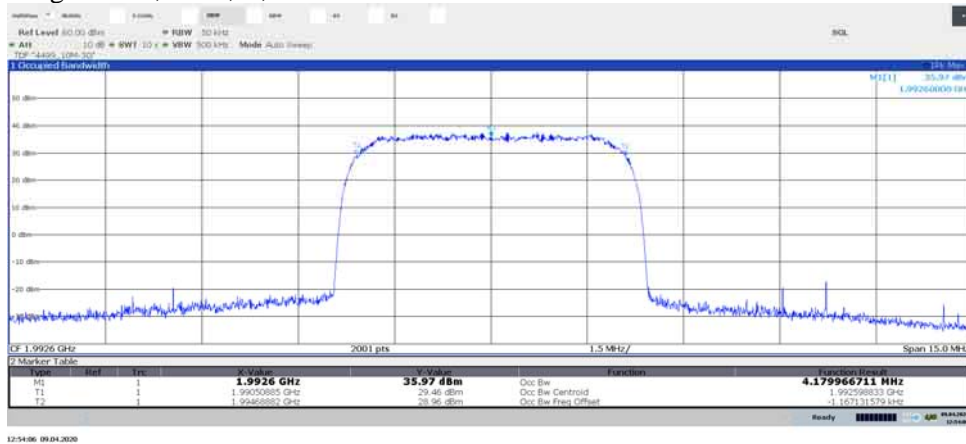


Diagram 1.7, TM5, M, Port A:

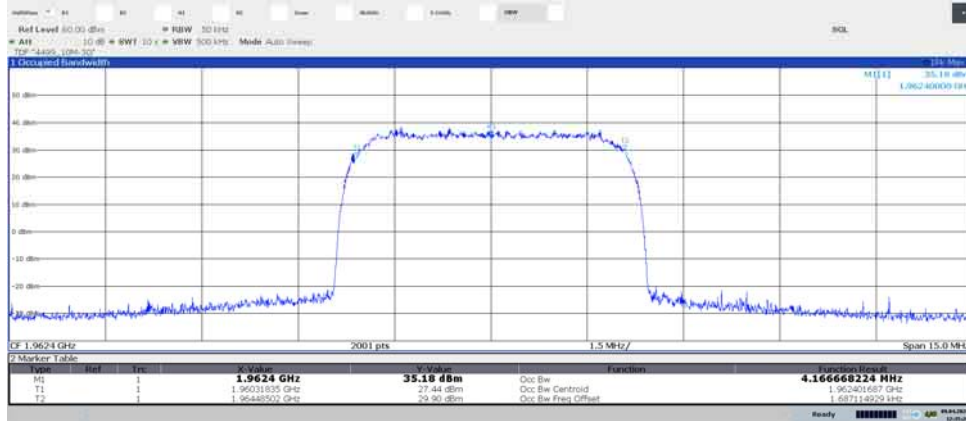


Diagram 1.8, TM6, M, Port A:

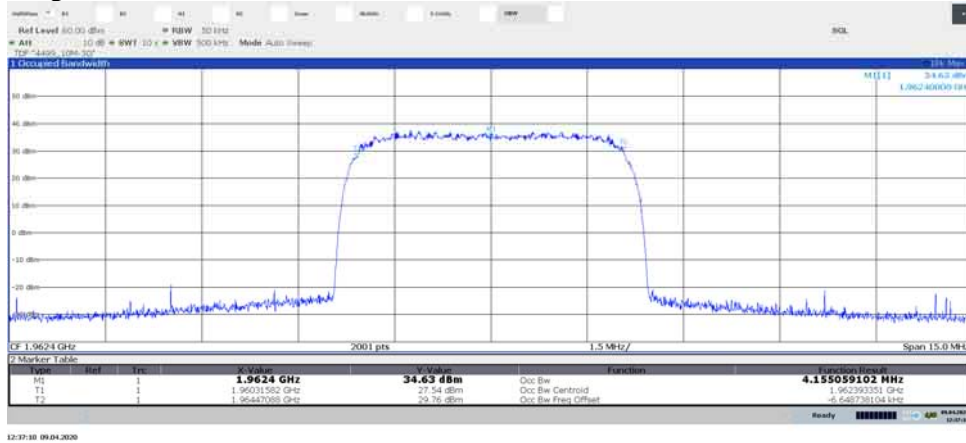


Diagram 1.9, TM1, B, Port B:

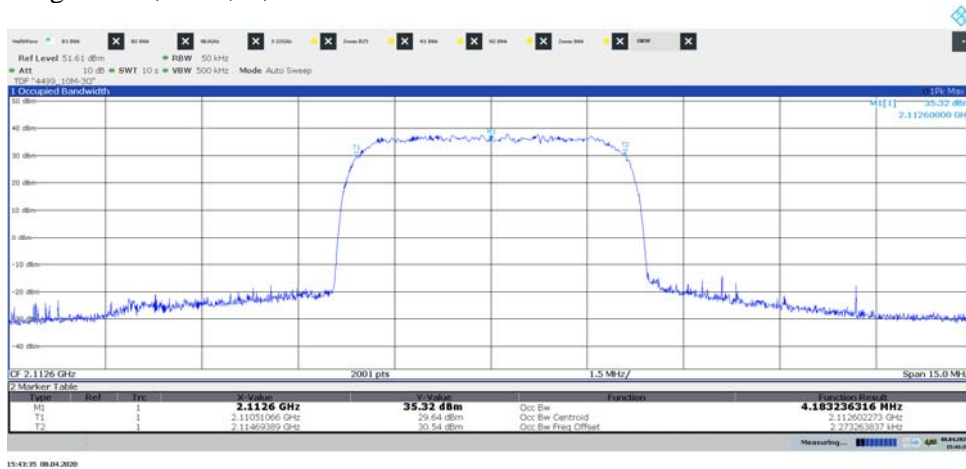


Diagram 1.10, TM1, M, Port A:

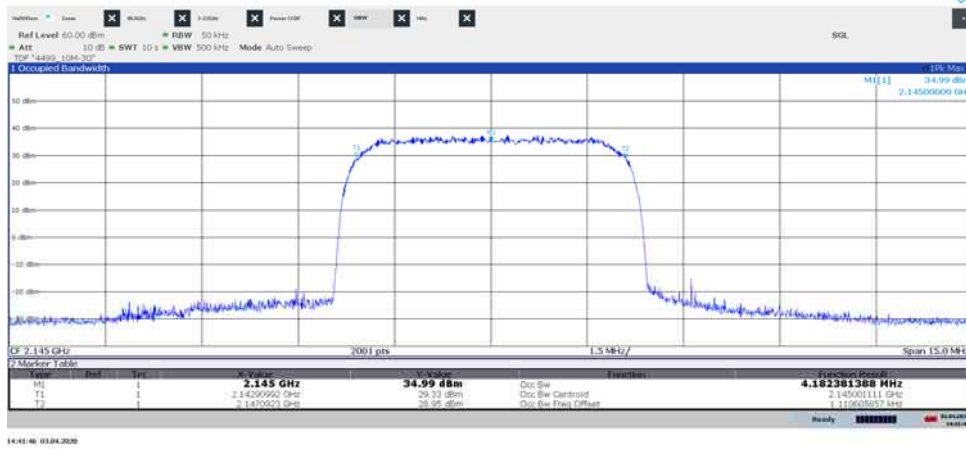


Diagram 1.11, TM1, M, Port B:

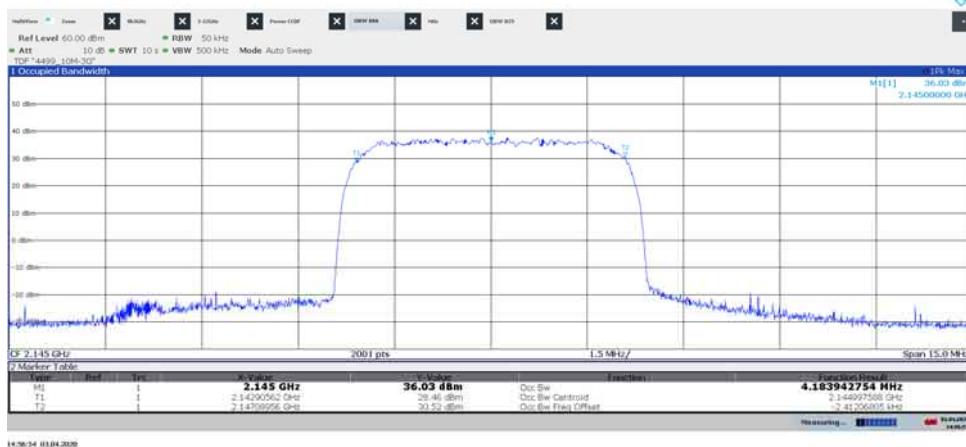


Diagram 1.12, TM1, M, Port C:

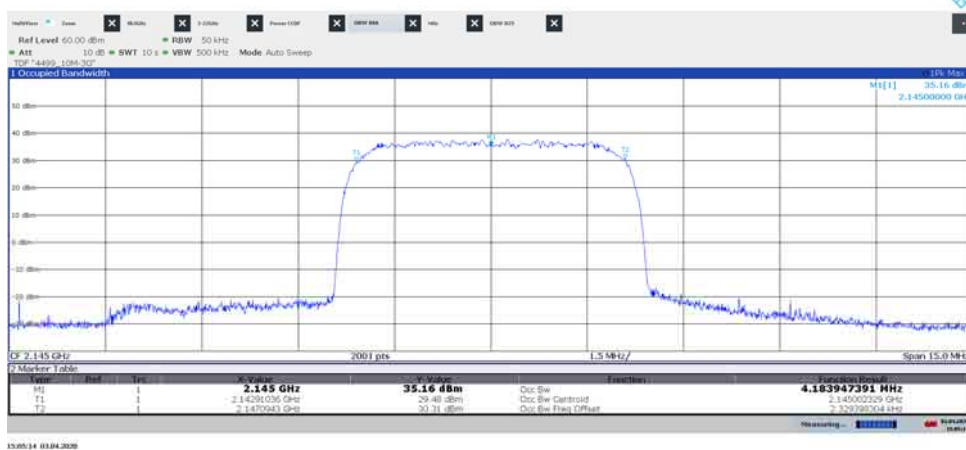


Diagram 1.13, TM1, M, Port D:

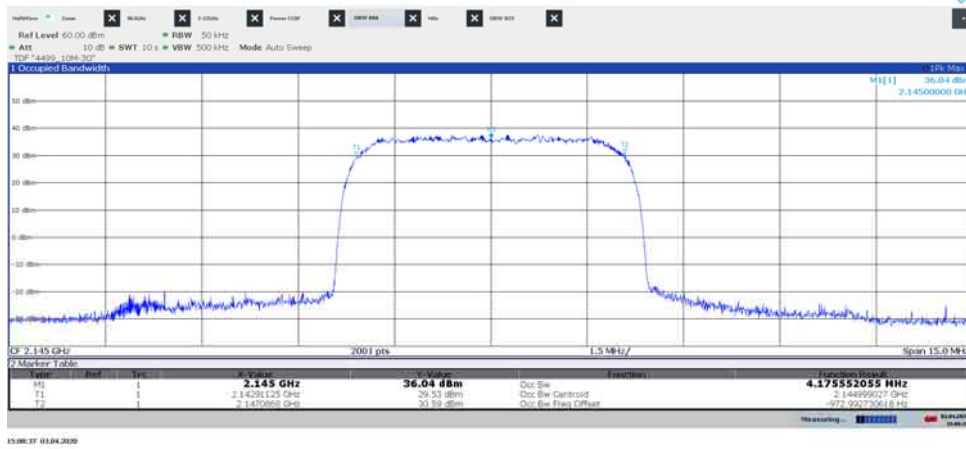


Diagram 1.14, TM1, T, Port B:

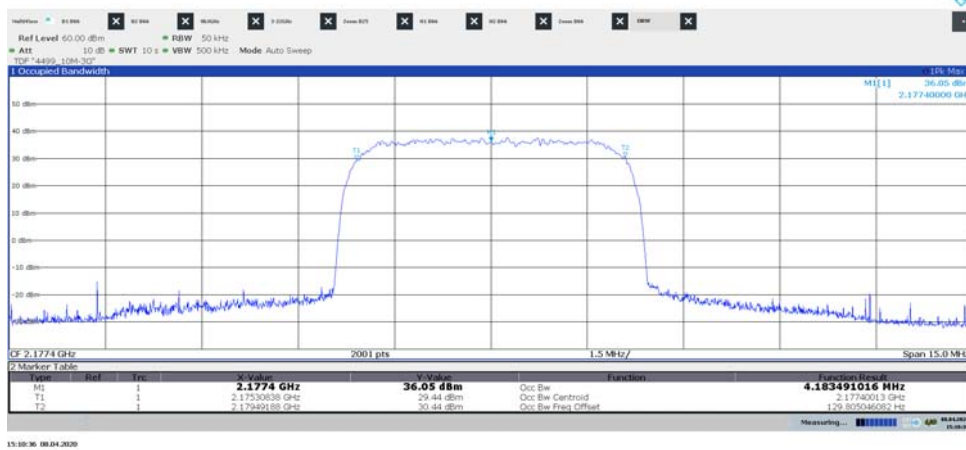


Diagram 1.15, TM5, M, Port B:

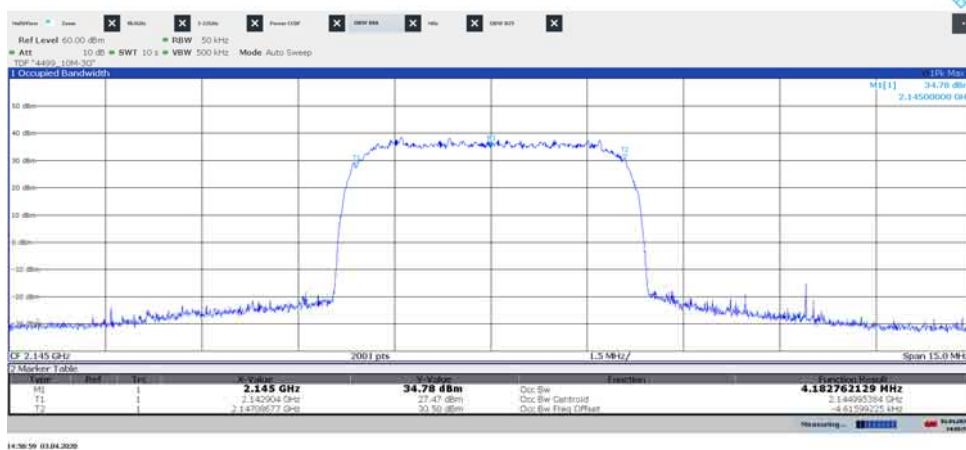
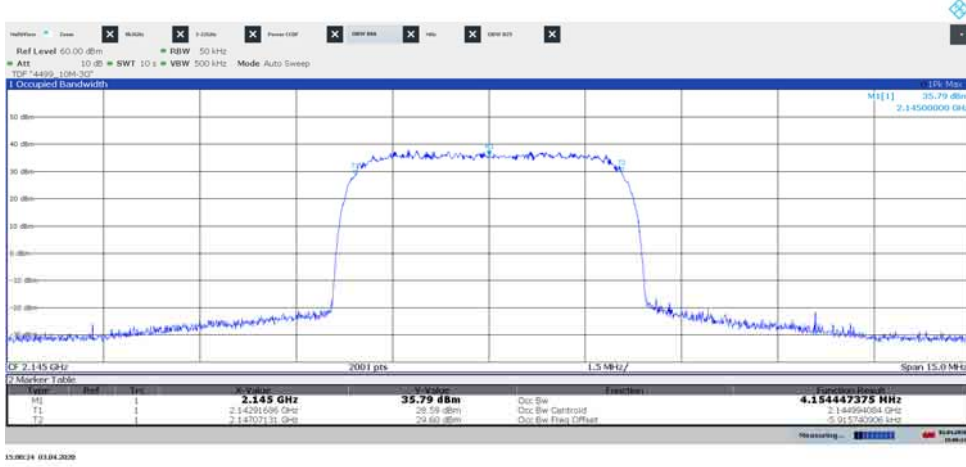


Diagram 1.16, TM1, B, Port A:



**Band edge measurements according to CFR 47 §24.238 and §27.53/
RSS-133 6.5, RSS-139 6.6**

Date	Temperature	Humidity
2020-04-09	22 °C ± 3 °C	13 % ± 5 %
2020-04-14	22 °C ± 3 °C	10 % ± 5 %
2020-05-05	22 °C ± 3 °C	14 % ± 5 %

Test set-up and procedure

The measurements were made per definition in ANSI C63.26, 5.7.3. The test object was connected to a spectrum analyzer with the RMS detector activated.

A RBW of 1% of EBW may be used up to 1 MHz away from the band edges. A smaller resolution bandwidth is permitted provided that the measured power is integrated over the full required measurement bandwidth.

From 1 MHz to 30 MHz away from the band edges a RBW of 100 kHz was used. To compensate for the reduced RBW the limit was adjusted by 10 dB to -23 dBm in this frequency range.

A RBW 1% of EBW was used up to 1 MHz away from the band edges. A smaller resolution bandwidth is permitted provided that the measured power is integrated over the full required measurement bandwidth. Where a smaller RBW was used the limit in the plot is adjusted by $10 \log (RBW_{used}/RBW_{specified})$ [dB] according to the following table:

Carrier BW:	RBW _{used}	RBW _{specified} (1% of EBW)	Limit correction	Adjusted limit
5 MHz	10 kHz	46.4 kHz	-6.7 dBm	-19.7 dBm

Before comparing the results to the limit, 6 dB [$10 \log (4)$] to cover 4x4 MIMO, should be added according to ANSI C63.26 6.4.4.1 c “measure and add $10 \log(N_{ANT})$ ”.

Measurement equipment	RISE number
R&S FSW 43	902 073
Directional coupler	901 496
RF attenuator	902 282
Coaxial cable Megaphase	BX50191
Coaxial cable Sucoflex 102EA	BX50237
Testo 635, temperature and humidity meter	504 203

Measurement uncertainty: 3.7 dB

Results WCDMA

B25 max power configuration:

Single carrier TM1

Diagram	Symbolic name	Tested Port
2.1 a-b	B	RF A
2.2 a-b	B	RF B
2.3 a-b	B	RF C
2.4 a-b	B	RF D
2.5 a-b	T	RF A
2.6 a-b	T	RF B
2.7 a-b	T	RF C
2.8 a-b	T	RF D

Single carrier TM5

Diagram	Symbolic name	Tested Port
2.9 a-b	B	RF A
2.10 a-b	T	RF A

Single carrier TM6

Diagram	Symbolic name	Tested Port
2.11 a-b	B	RF A
2.12 a-b	T	RF A

Multi carrier TM1

Diagram	Symbolic name	Tested Port
2.13 a-b	Bim	RF A
2.14 a-b	Tim	RF A

B2 max power configuration:

Single carrier TM1

Diagram	Symbolic name	Tested Port
2.15 a-b	T	RF A
2.16 a-b	T	RF B
2.17 a-b	T	RF C
2.18 a-b	T	RF D

B66 max power configuration:

Single carrier TM1

Diagram	Symbolic name	Tested Port
2.19 a-b	B	RF A
2.20 a-b	B	RF B
2.21 a-b	B	RF C
2.22 a-b	B	RF D
2.23 a-b	T	RF A
2.24 a-b	T	RF B
2.25 a-b	T	RF C
2.26 a-b	T	RF D

Single carrier TM5

Diagram	Symbolic name	Tested Port
2.27 a-b	B	RF B
2.28 a-b	T	RF B

Single carrier TM6

Diagram	Symbolic name	Tested Port
2.29 a-b	B	RF B
2.30 a-b	T	RF B

Multi carrier TM1

Diagram	Symbolic name	Tested Port
2.31 a-b	Bim	RF B
2.32 a-b	Tim	RF B

Results WCDMA+NB IoT SA

B25 max power configuration:

Multi RAT: NB IoT SA: N-TM, WCDMA: TM1

Diagram	Symbolic name	Tested Port
2.33 a-b	Bim _{IoT+W}	RF A
2.34 a-b	Tim _{IoT+W}	RF A

B66 max power configuration:

Multi RAT: NB IoT SA: N-TM, WCDMA: TM1

Diagram	Symbolic name	Tested Port
2.35 a-b	Bim _{IoT+W}	RF B
2.36 a-b	Tim _{IoT+W}	RF B

Results WCDMA+GSM+NB IoT SA

B2 max power configuration:

Multi RAT: GSM: GMSK, NB IoT SA: N-TM, WCDMA: TM1

Diagram	Symbolic name	Tested Port
2.37 a-b	Bim _{G+IoT+W}	RF A
2.38 a-b	Tim _{G+IoT+W}	RF A

Limits

CFR 47 §24.238, §27.53(h) and RSS-133 6.5, RSS-139 6.6

- i. In the 1.0 MHz bands immediately outside and adjacent to the equipment’s operating frequency block, the emission power per any 1% of the emission bandwidth shall be attenuated (in dB) below the transmitter output power P (dBW) by at least $43 + 10 \log_{10}(watts)$.
- ii. After the first 1.0 MHz, the emission power in any 1 MHz bandwidth shall be attenuated (in dB) below the transmitter output power P (dBW) by at least $43 + 10 \log_{10}(watts)$. If the measurement is performed using 1% of the emission bandwidth, power integration over 1.0 MHz is required.

Complies?	Yes
-----------	-----

Diagram 2.1a, TM1, B, Port A:

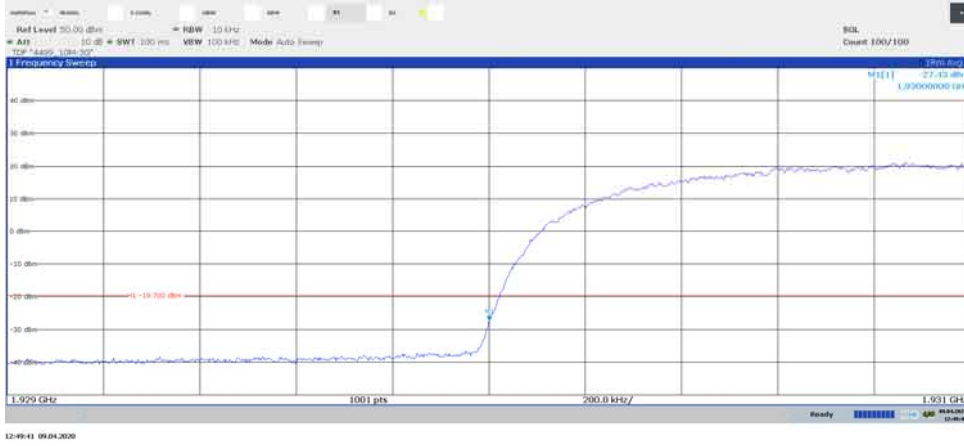


Diagram 2.1b, TM1, B, Port A:

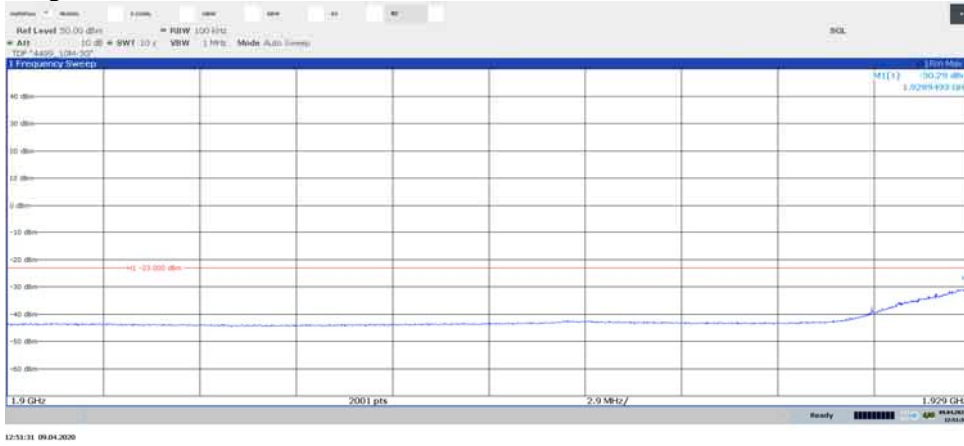


Diagram 2.2a, TM1, B, Port B:

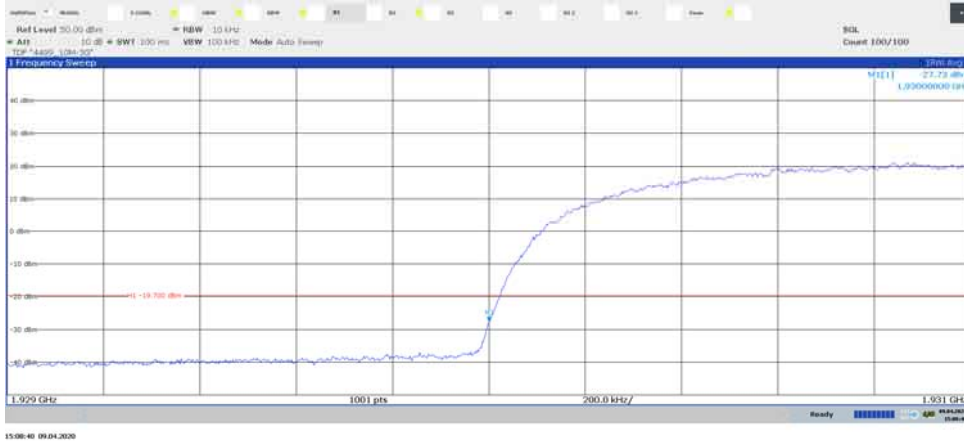


Diagram 2.2b, TM1, B, Port B:

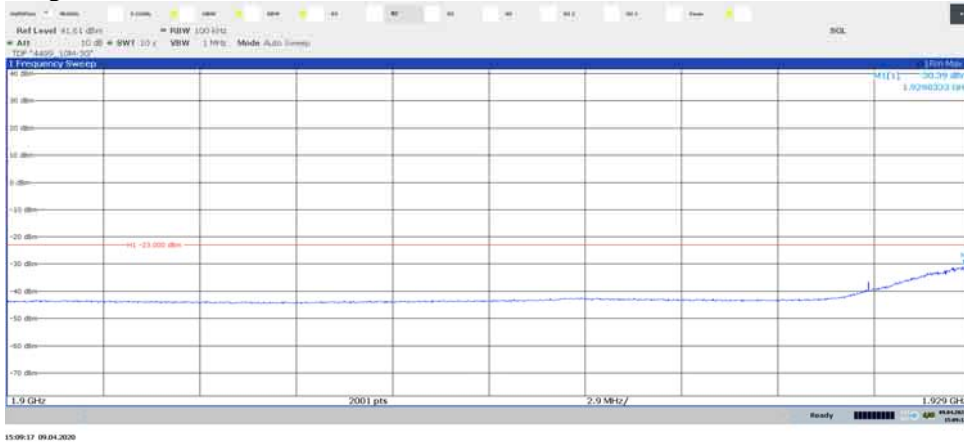


Diagram 2.3a, TM1, B, Port C:

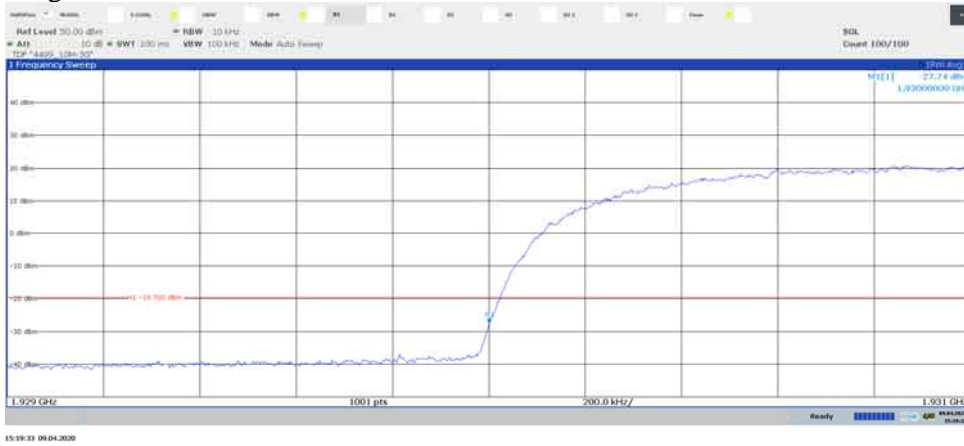


Diagram 2.3b, TM1, B, Port C:

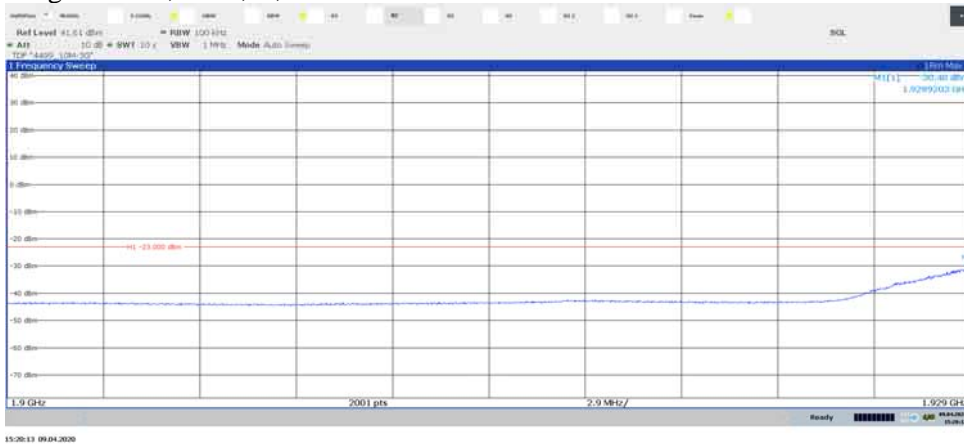


Diagram 2.4a, TM1, B, Port D:

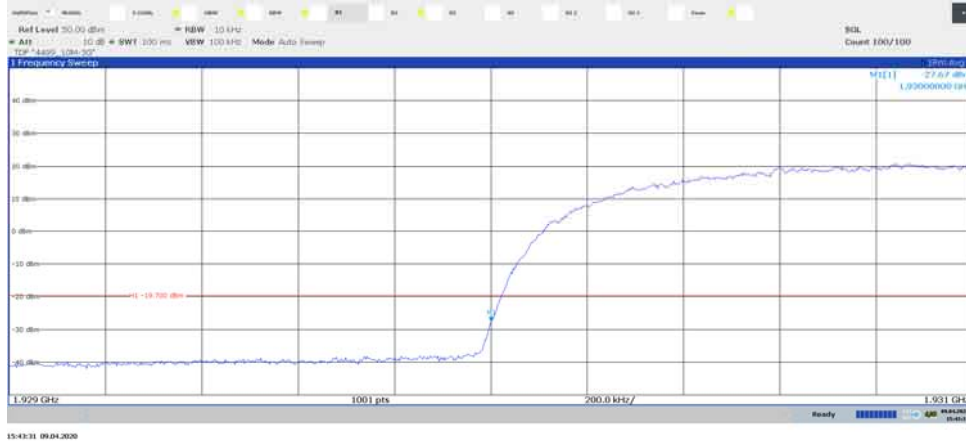


Diagram 2.4b, TM1, B, Port D:

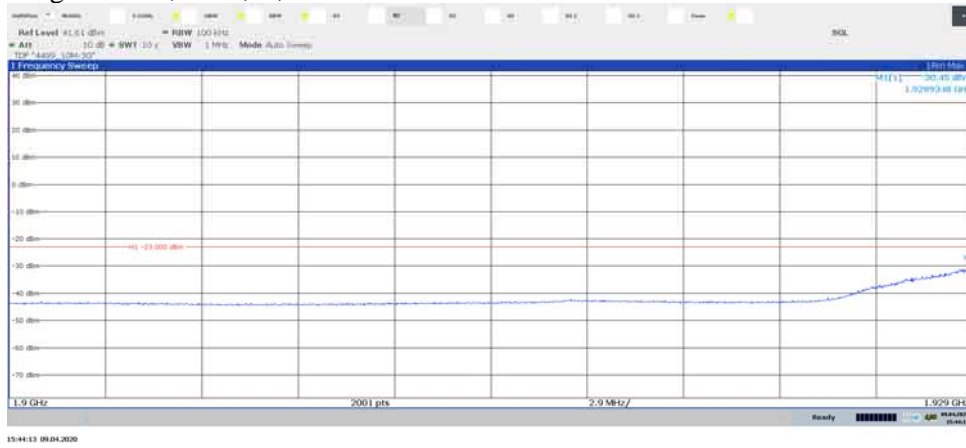


Diagram 2.5a, TM1, T, Port A:

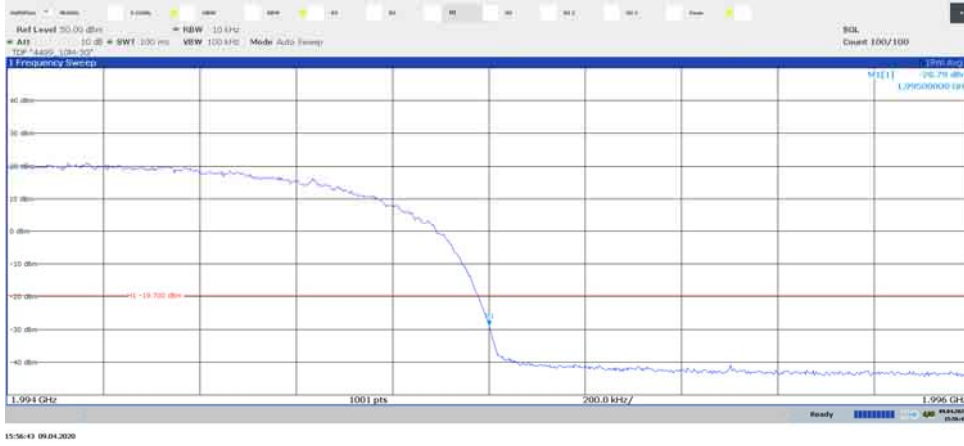


Diagram 2.5b, TM1, T, Port A:

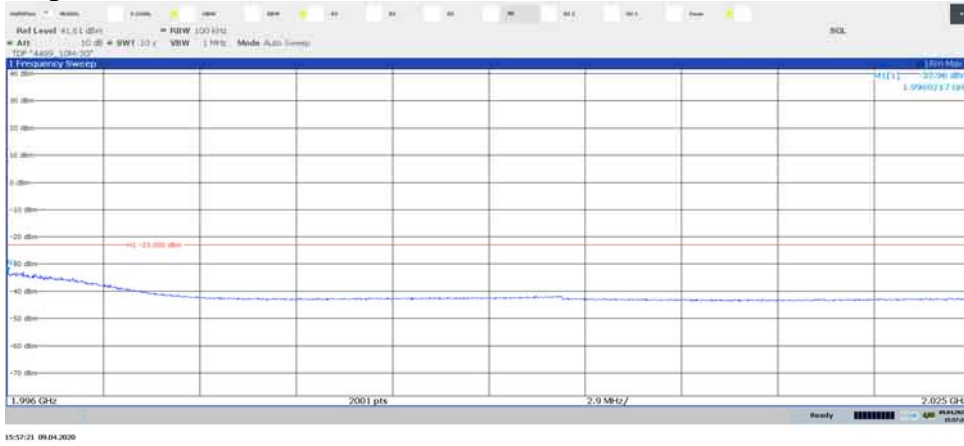


Diagram 2.6a, TM1, T, Port B:

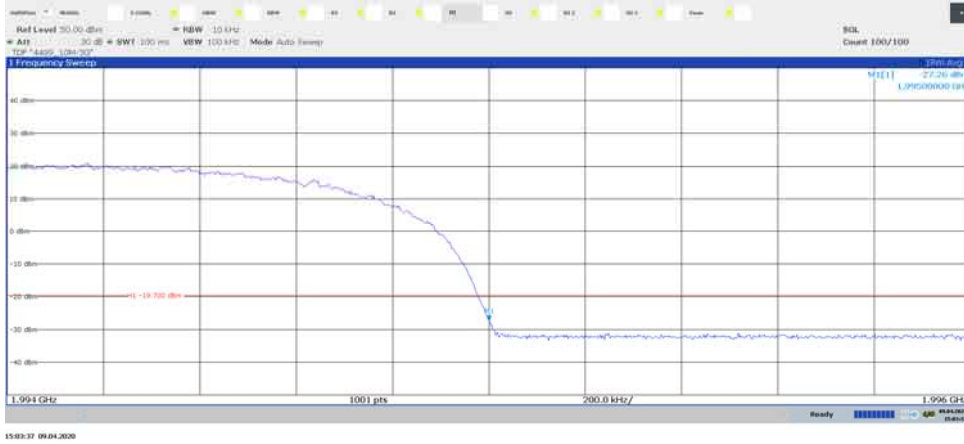


Diagram 2.6b, TM1, T, Port B:

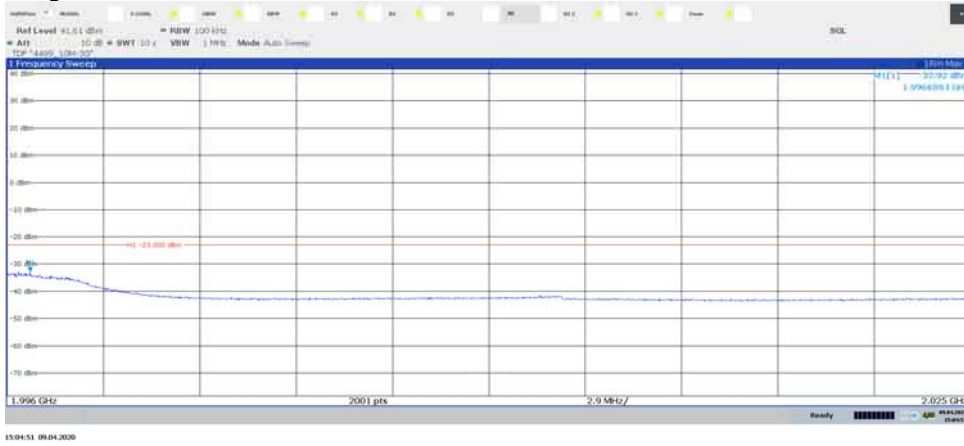


Diagram 2.7a, TM1, T, Port C:

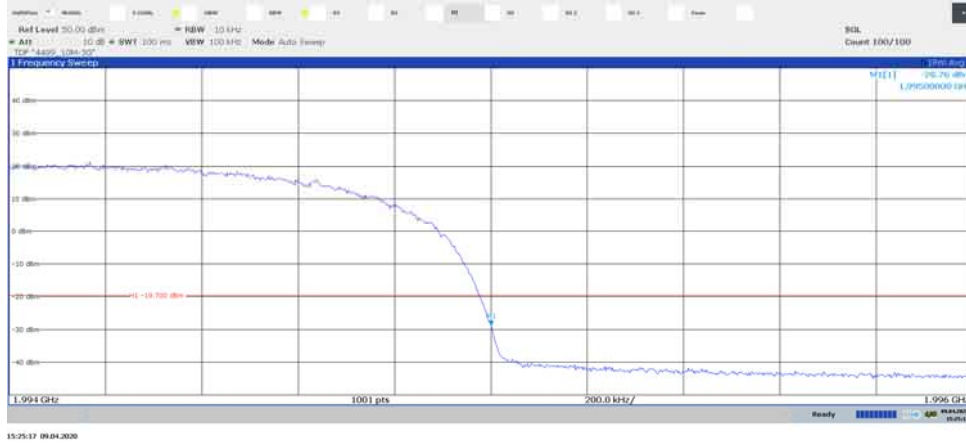


Diagram 2.7b, TM1, T, Port C:

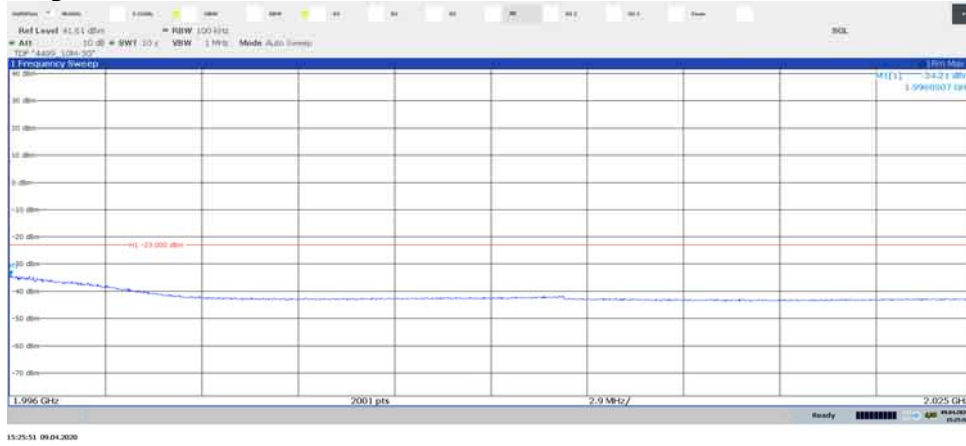


Diagram 2.8a, TM1, T, Port D:

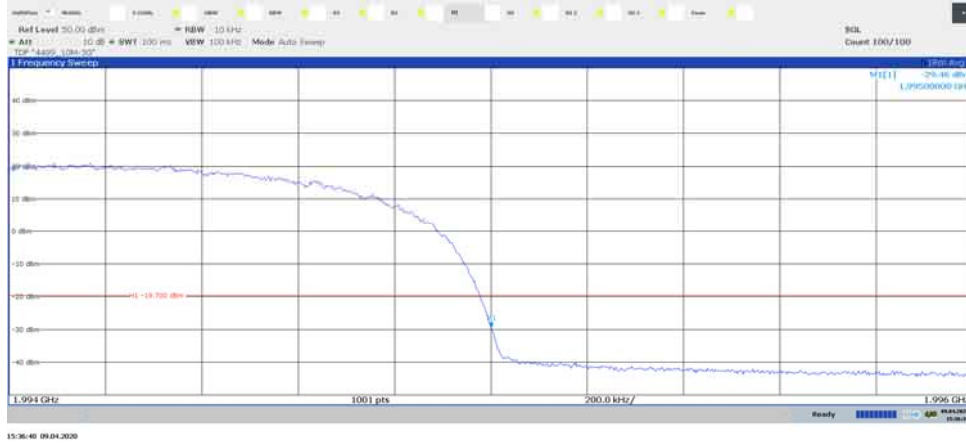


Diagram 2.8b, TM1, T, Port D:

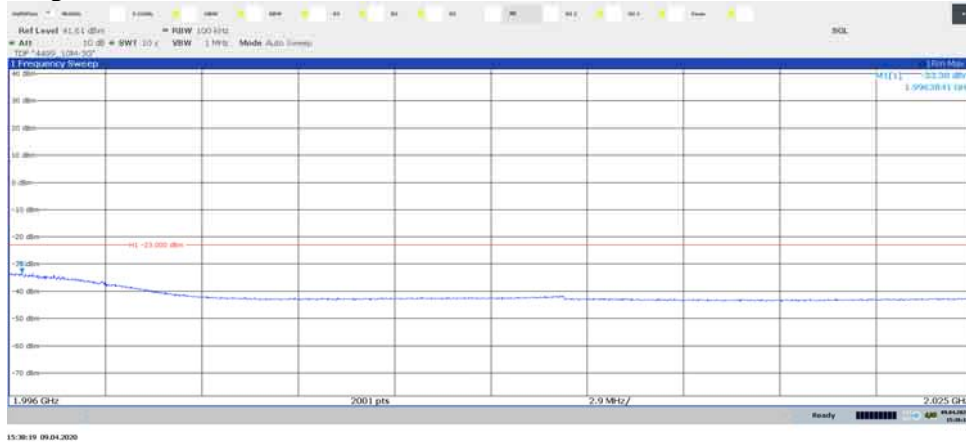


Diagram 2.9a, TM5, B, Port A:

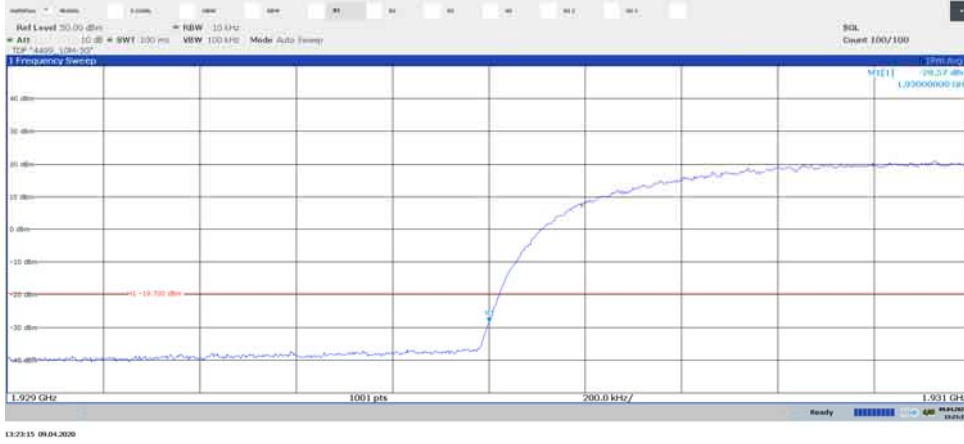


Diagram 2.9b, TM5, B, Port A:

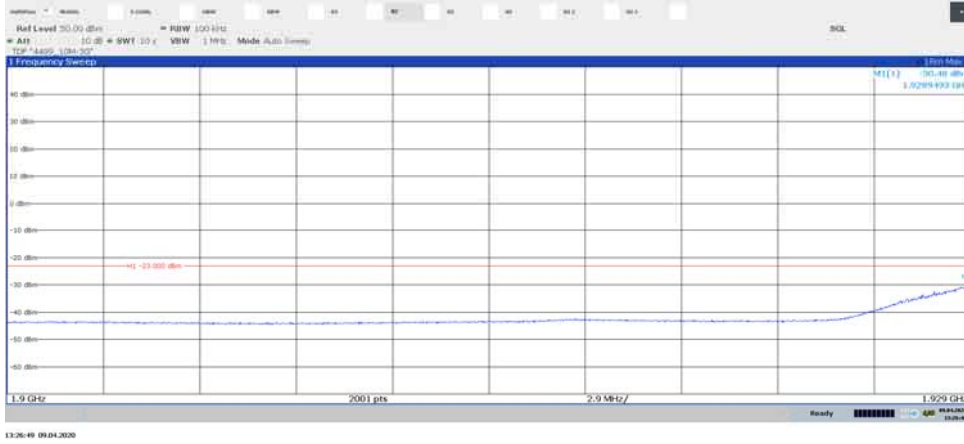


Diagram 2.10a, TM5, T, Port A:

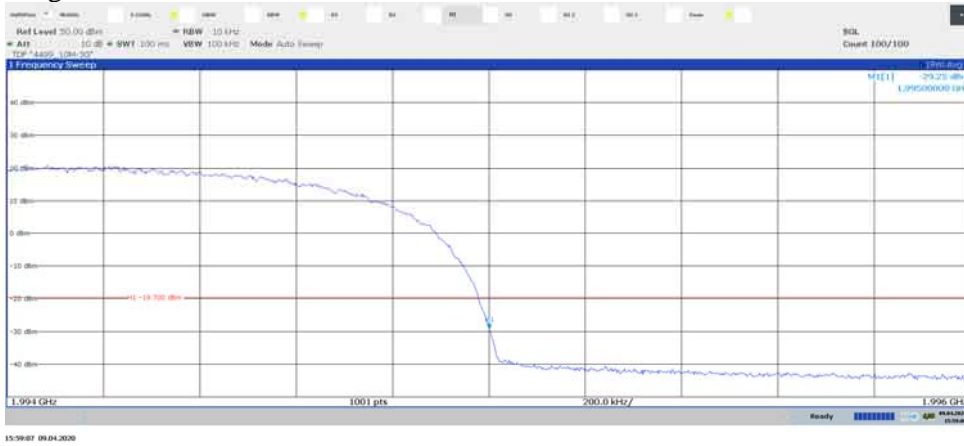


Diagram 2.10b, TM5, T, Port A:

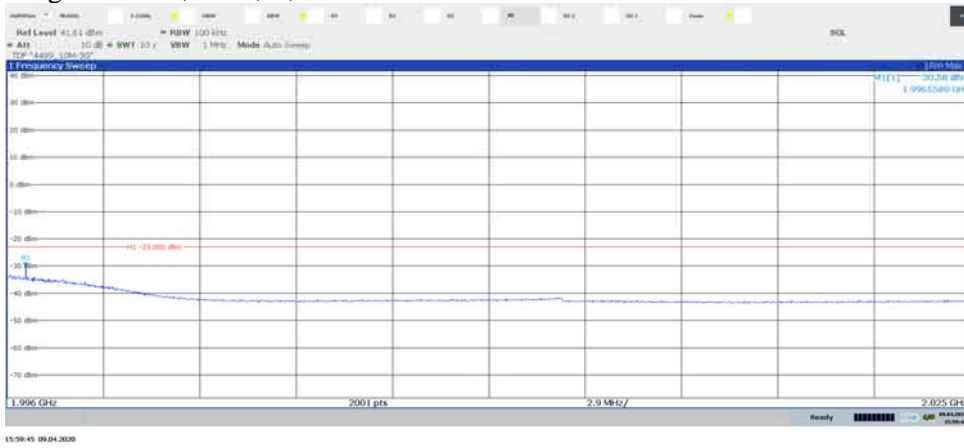


Diagram 2.11a, TM6, B, Port A:

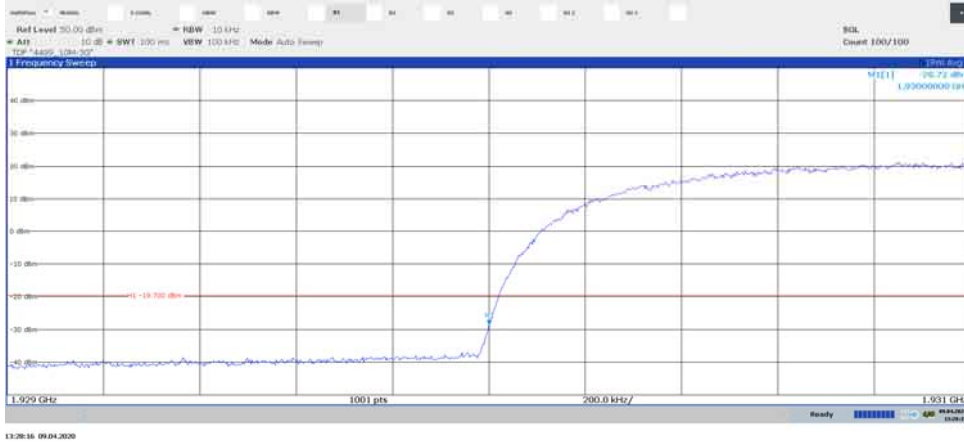


Diagram 2.11b, TM6, B, Port A:

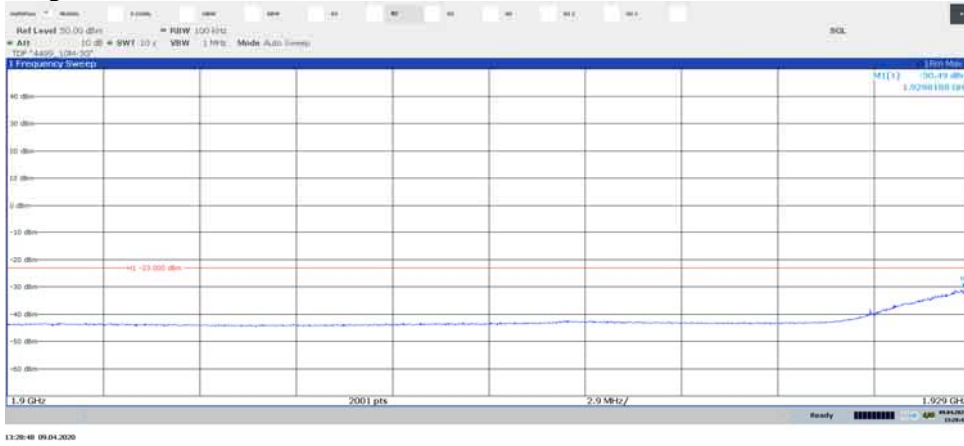


Diagram 2.12a, TM6, T, Port A:

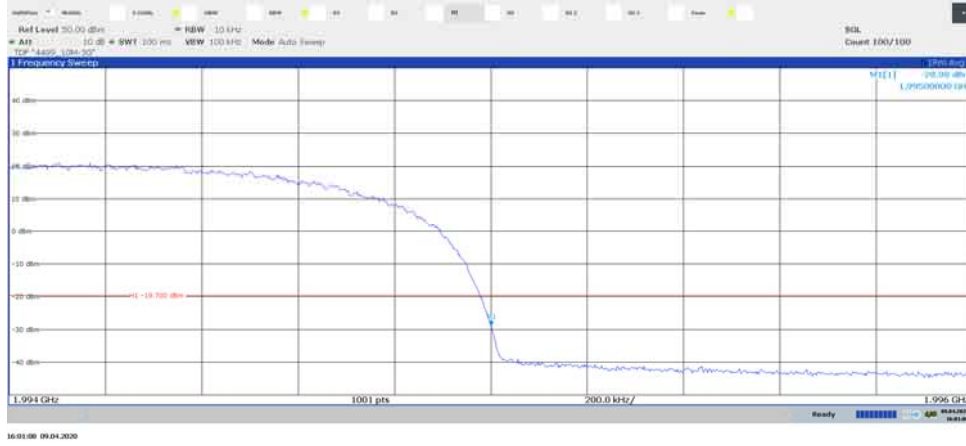


Diagram 2.12b, TM6, T, Port A:

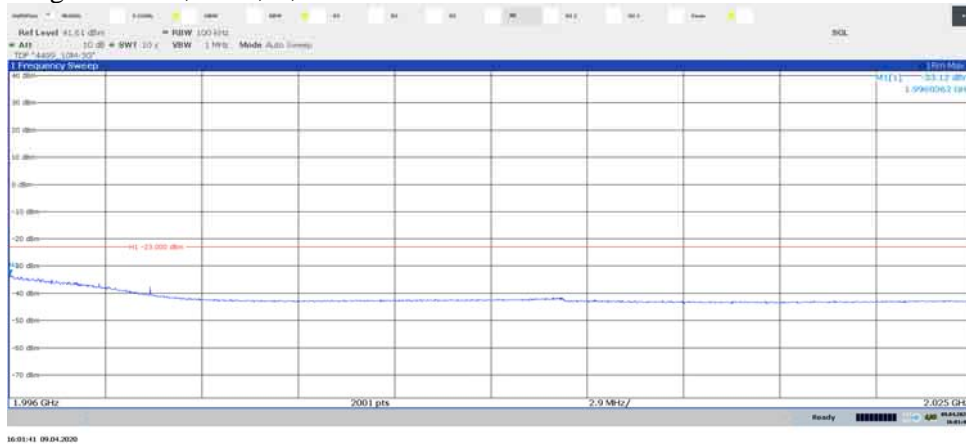


Diagram 2.13a, TM1, Bim, Port A:

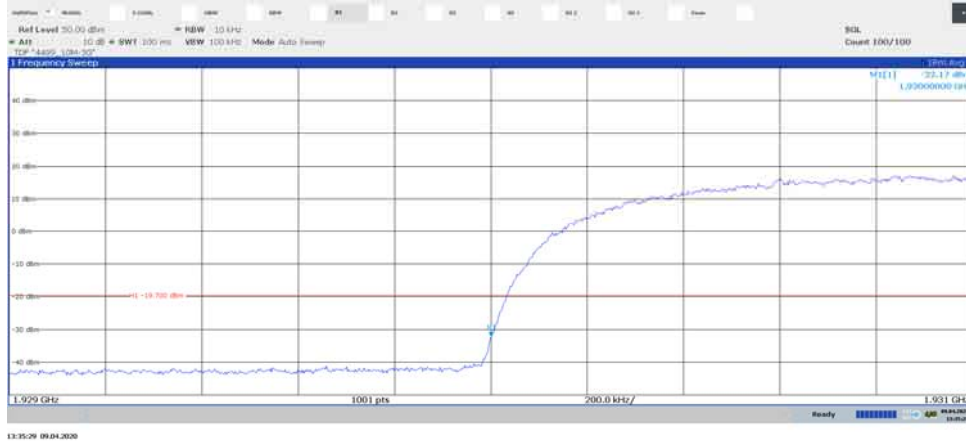


Diagram 2.13b, TM1, Bim, Port A:

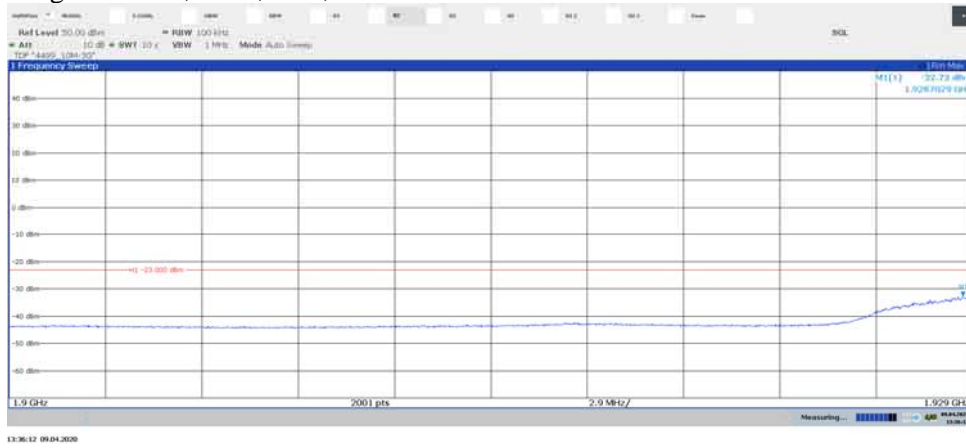


Diagram 2.14a, TM6, Tim, Port A:

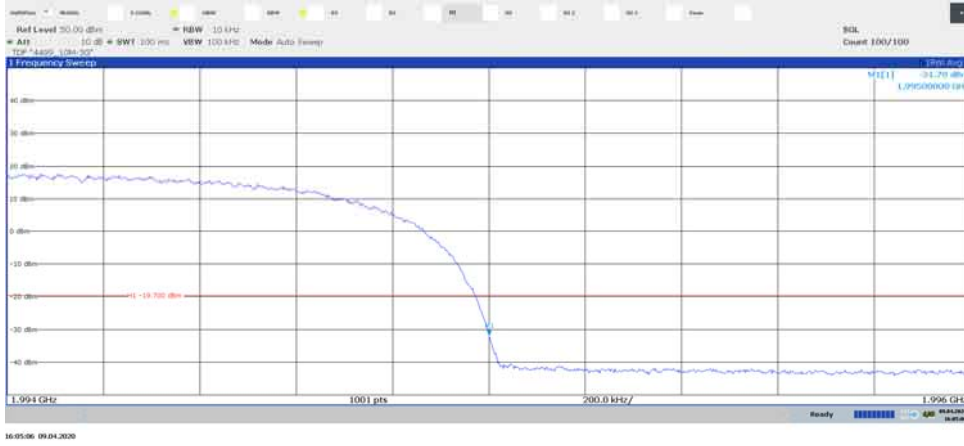


Diagram 2.14b, TM6, Tim, Port A:

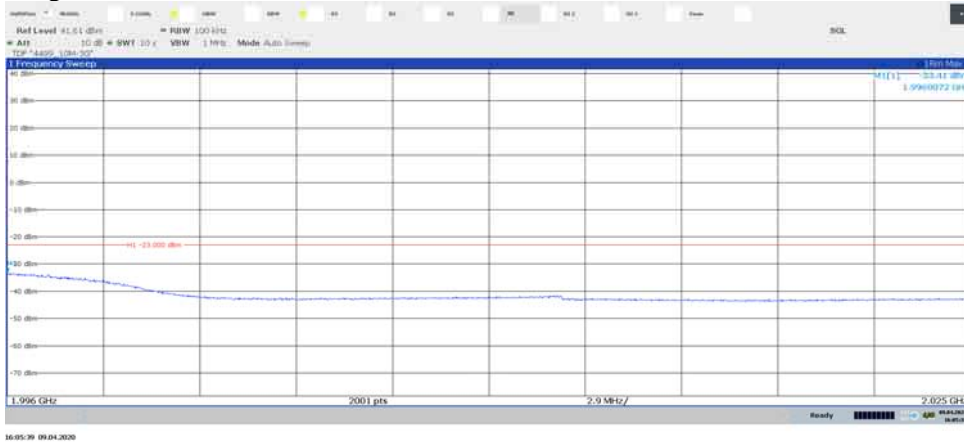


Diagram 2.15a, TM1, T, Port A:

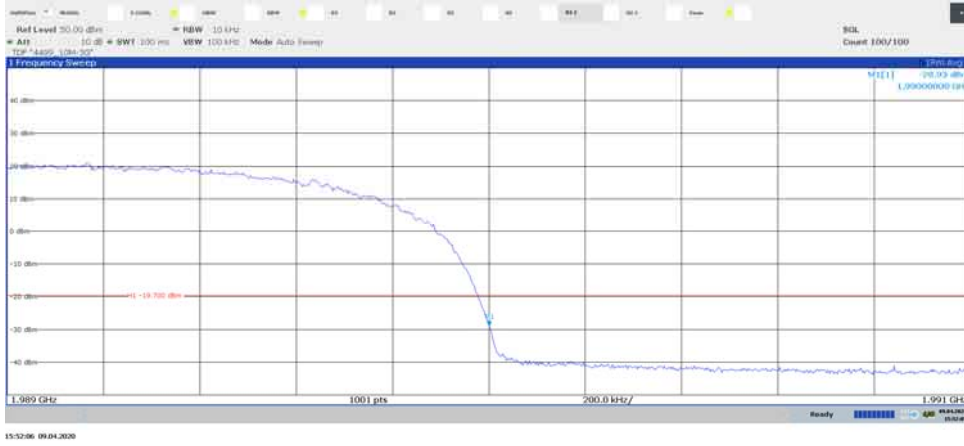


Diagram 2.15b, TM1, T, Port A:

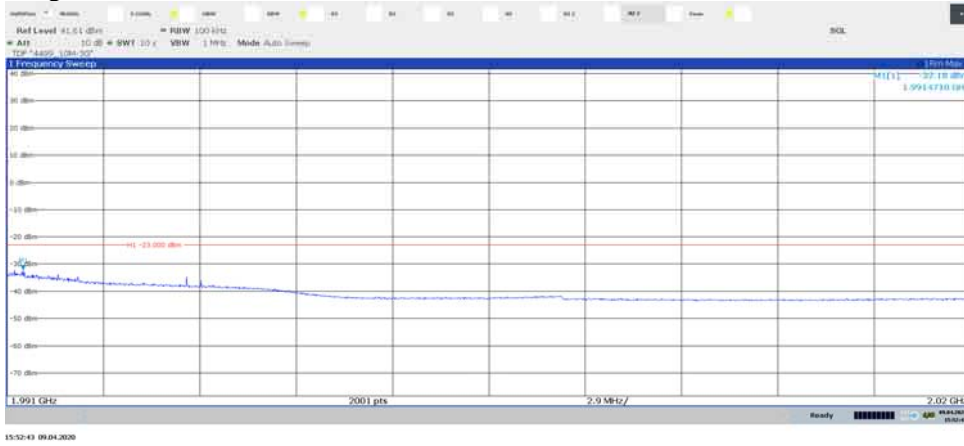


Diagram 2.16a, TM1, T, Port B:

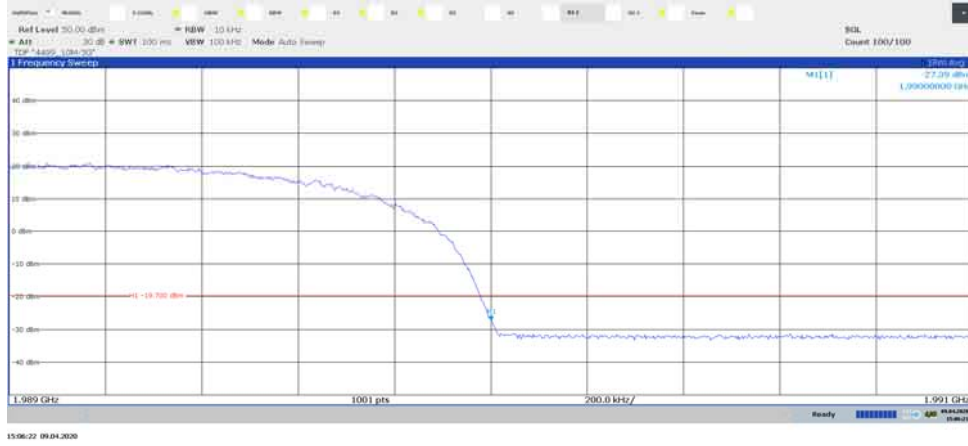


Diagram 2.16b, TM1, T, Port B:

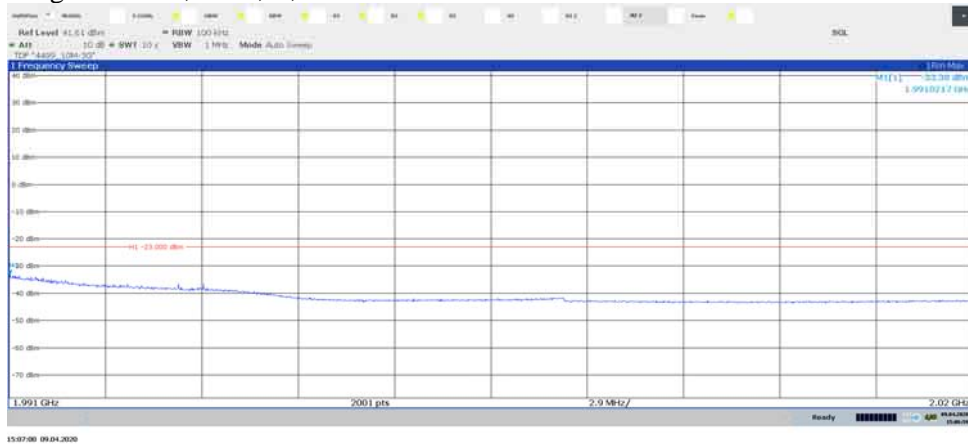


Diagram 2.17a, TM1, T, Port C:

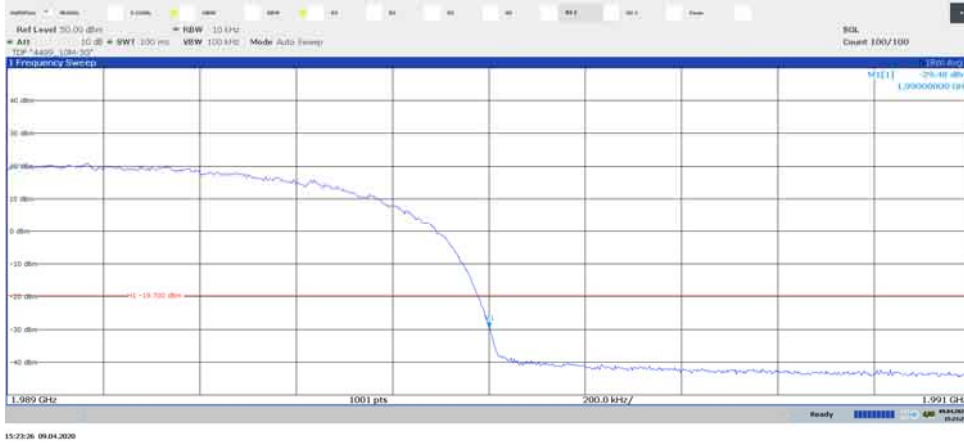


Diagram 2.17b, TM1, T, Port C:

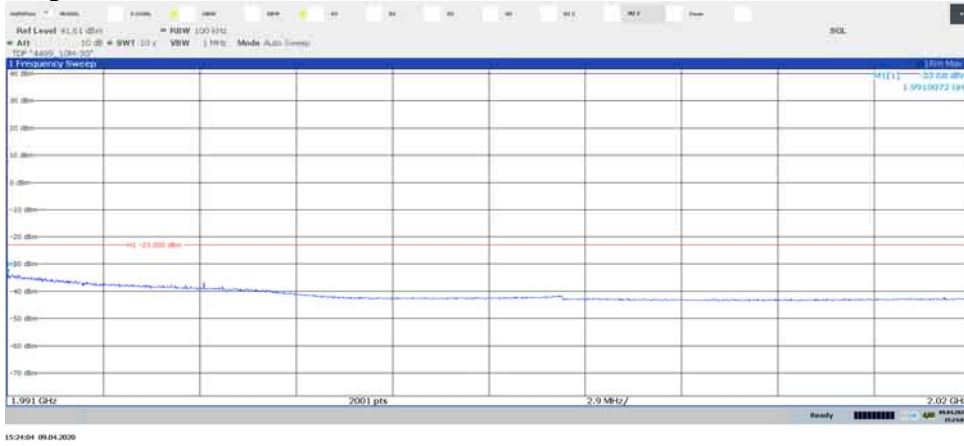


Diagram 2.18a, TM1, T, Port D:

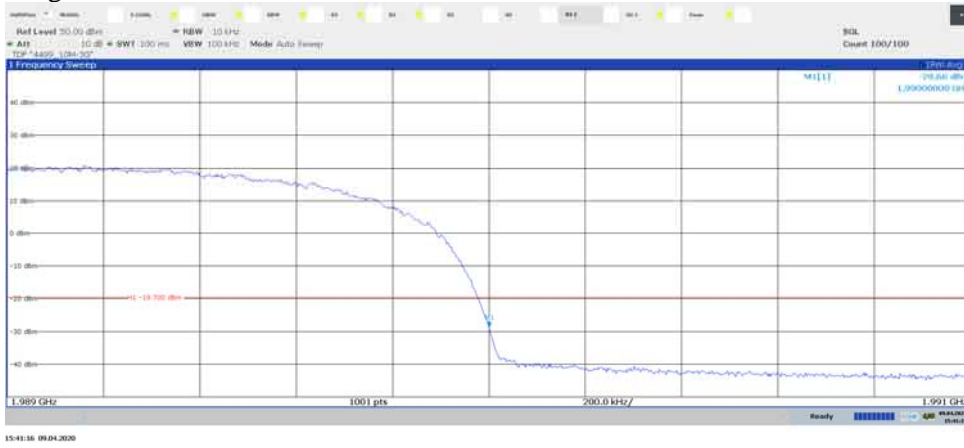


Diagram 2.18b, TM1, T, Port D:

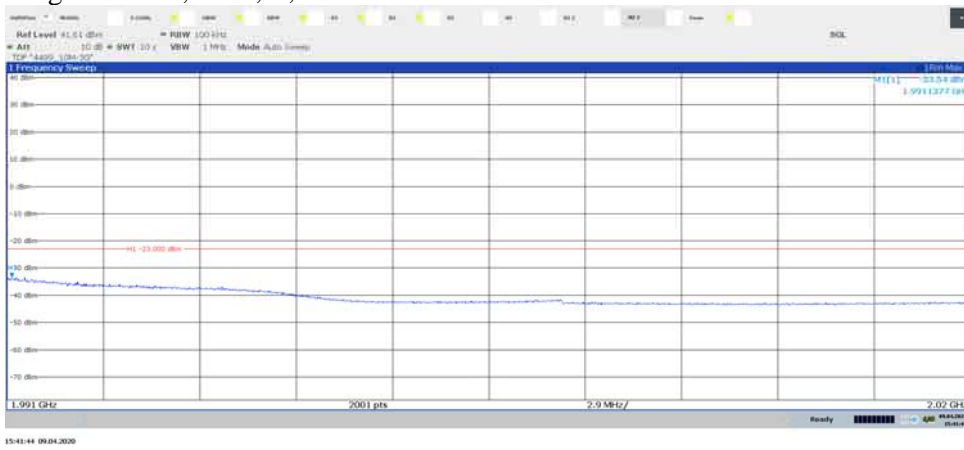


Diagram 2.19a, TM1, B, Port A:

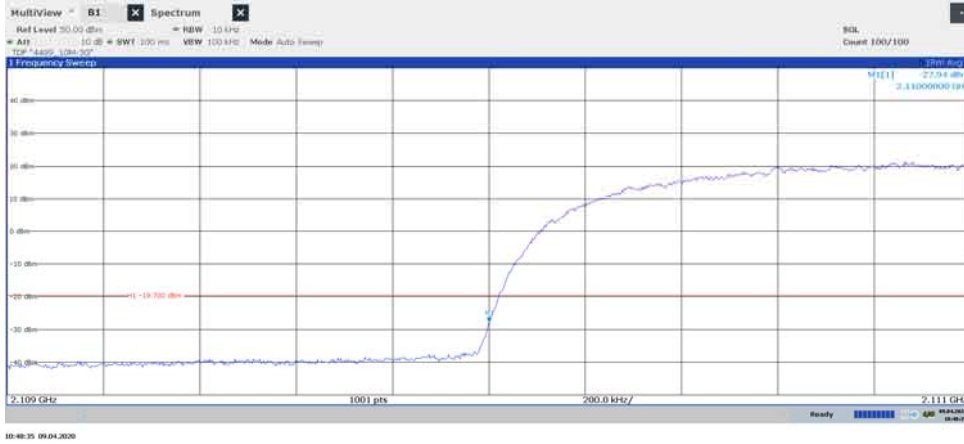


Diagram 2.19b, TM1, B, Port A:

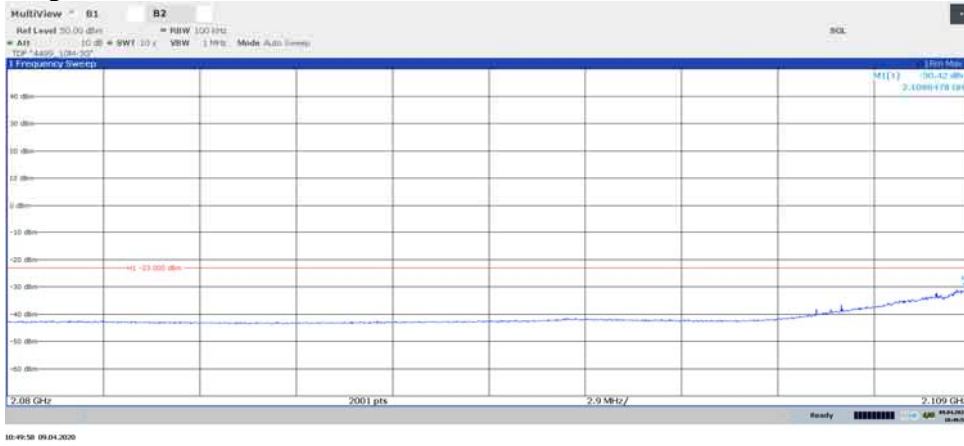


Diagram 2.20a, TM1, B, Port B:

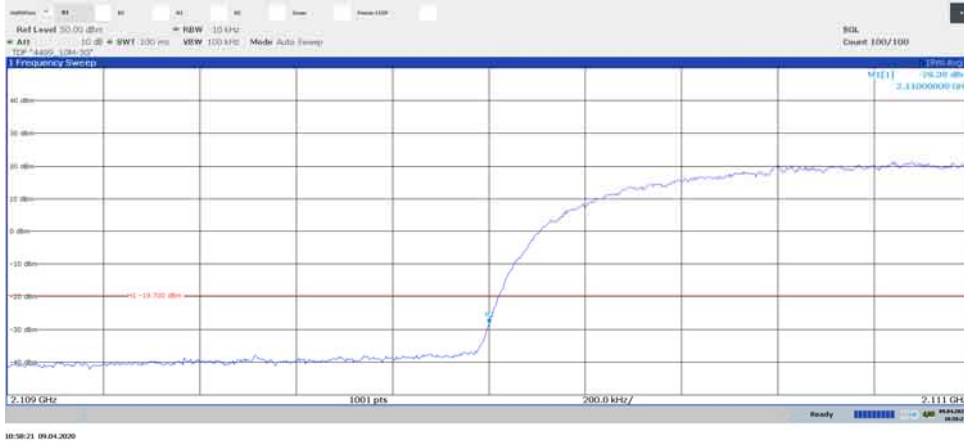


Diagram 2.20b, TM1, B, Port B:

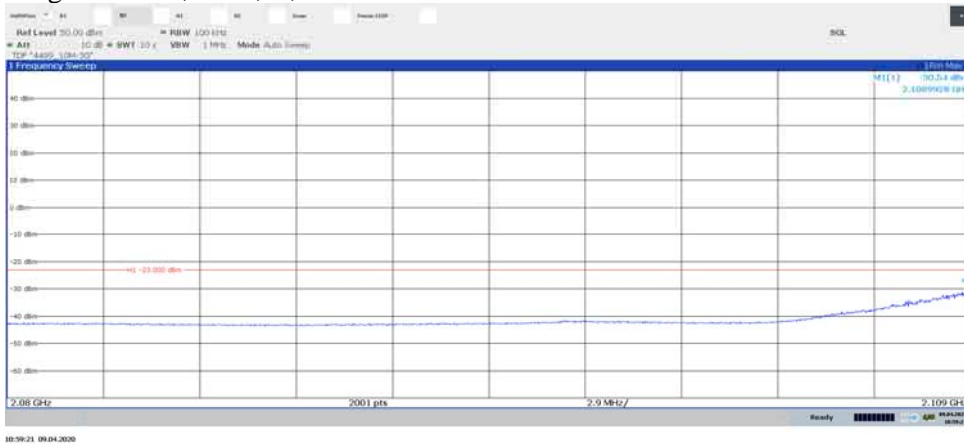


Diagram 2.21a, TM1, B, Port C:

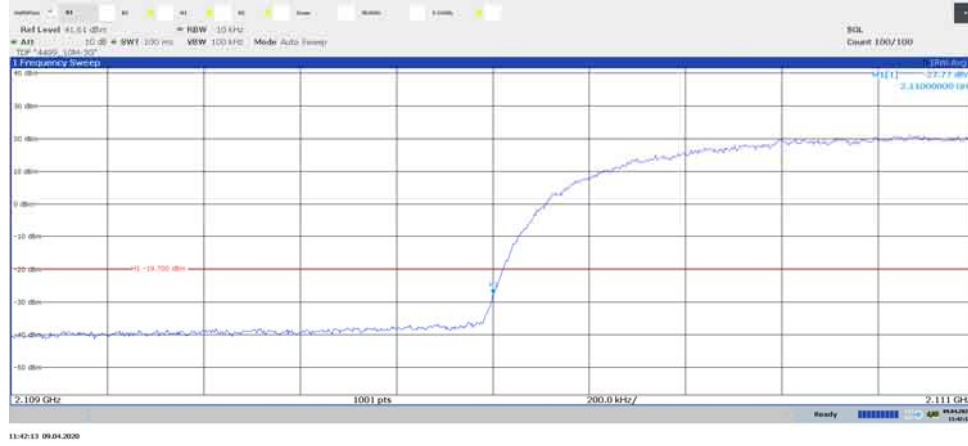


Diagram 2.21b, TM1, B, Port C:

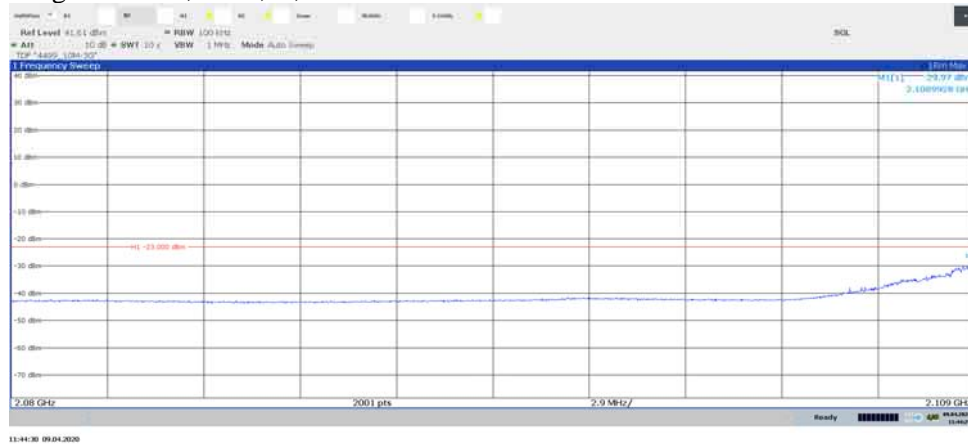


Diagram 2.22a, TM1, B, Port D:

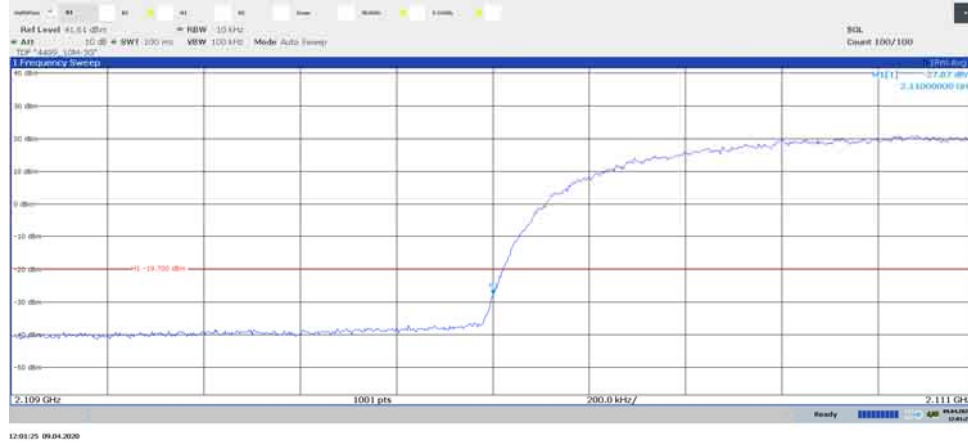


Diagram 2.22b, TM1, B, Port D:

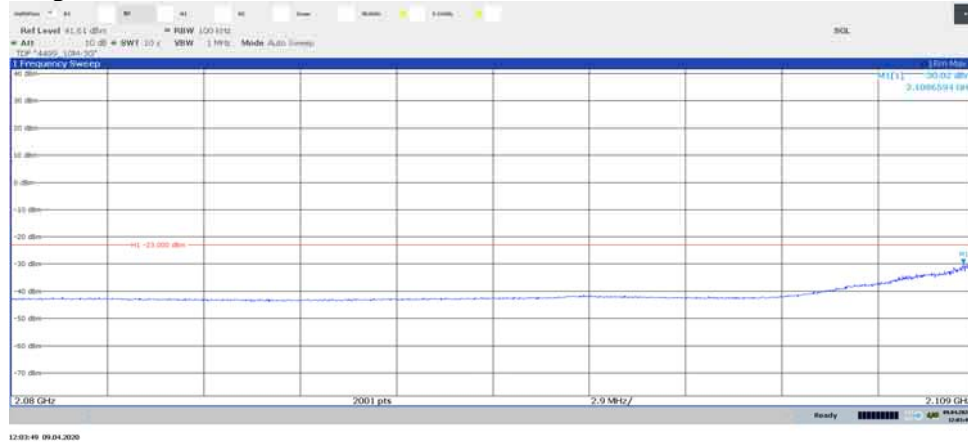


Diagram 2.23a, TM1, T, Port A:

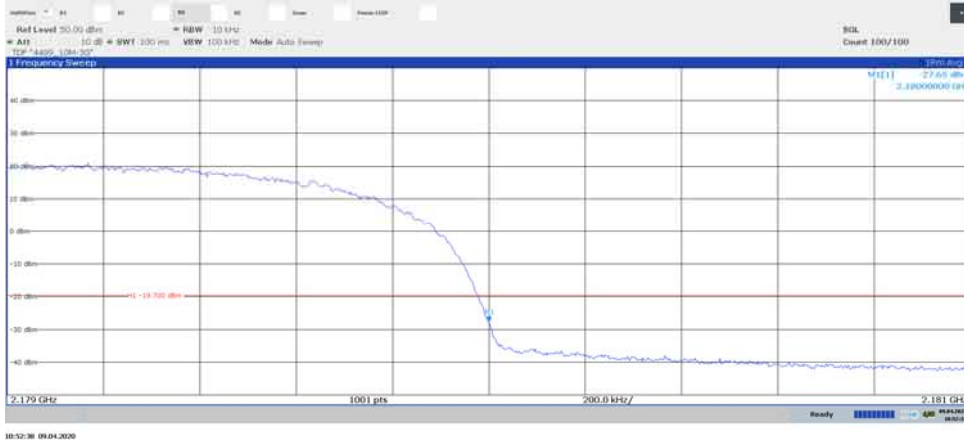


Diagram 2.23b, TM1, T, Port A:

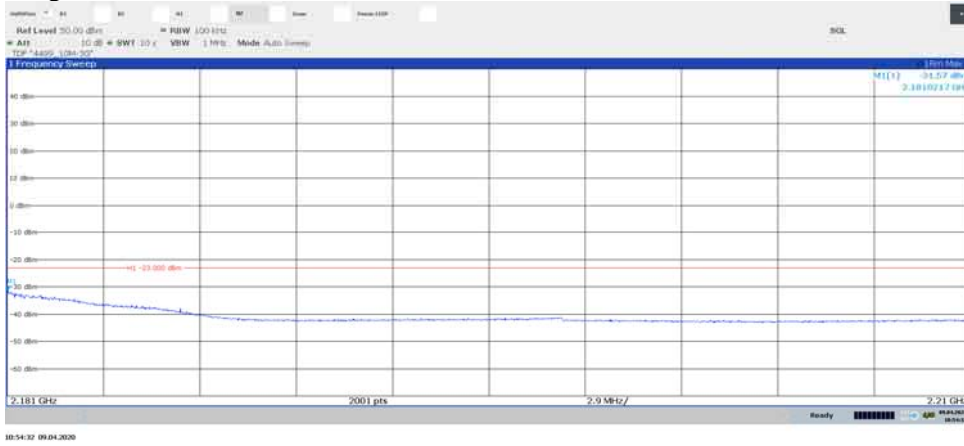


Diagram 2.24a, TM1, T, Port B:

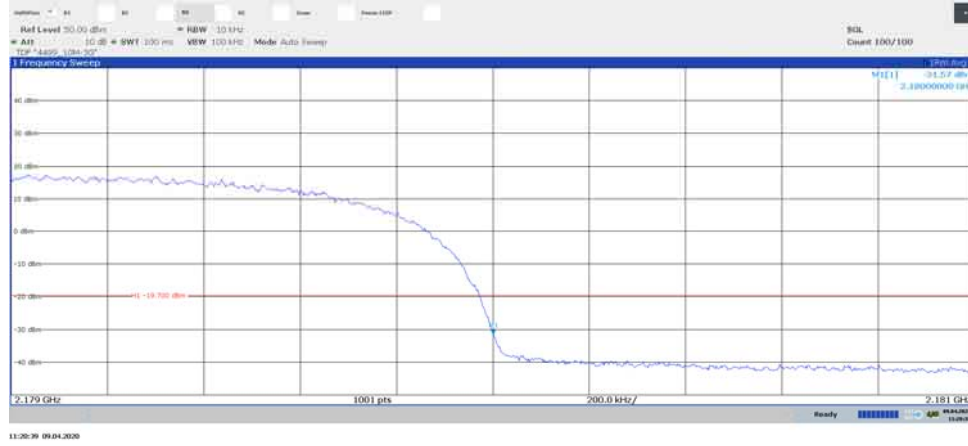


Diagram 2.24b, TM1, T, Port B:

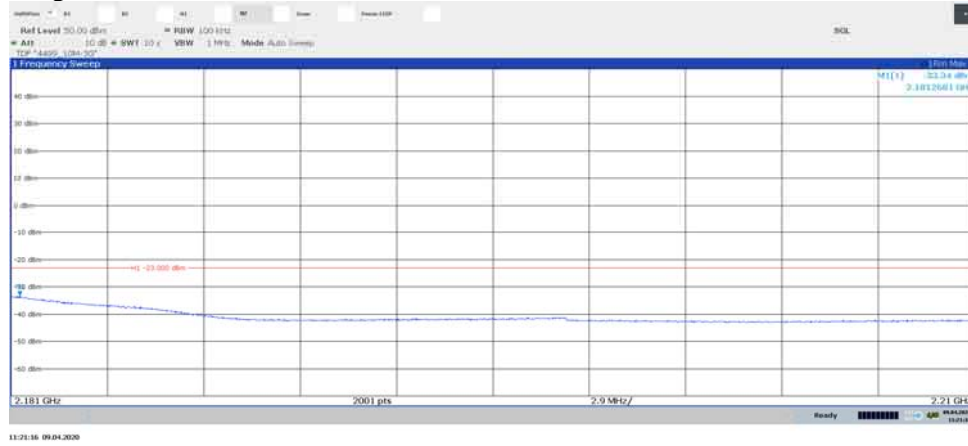


Diagram 2.25a, TM1, T, Port C:

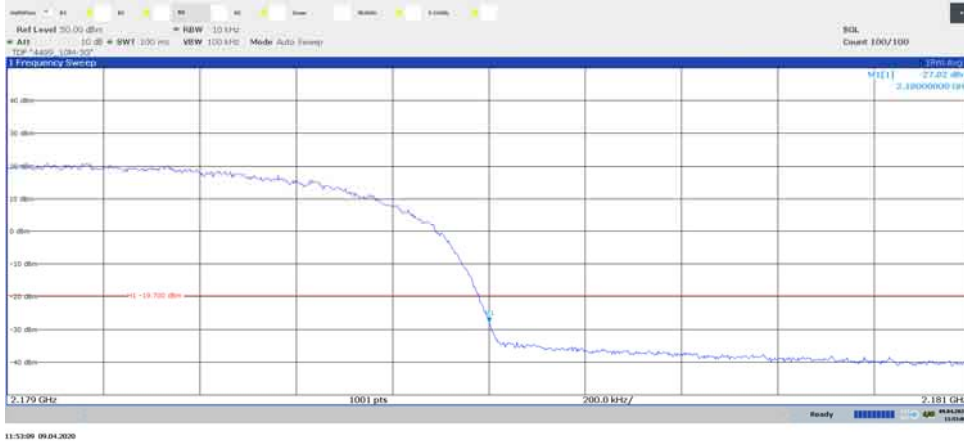


Diagram 2.25b, TM1, T, Port C:

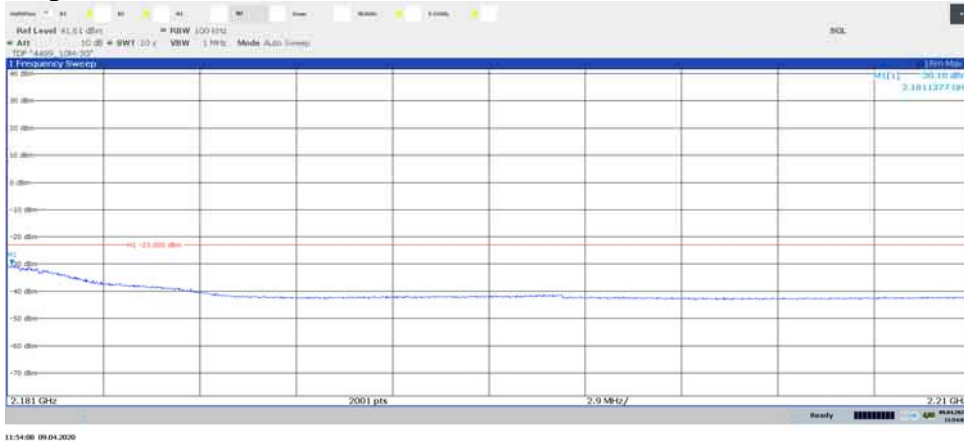


Diagram 2.26a, TM1, T, Port D:

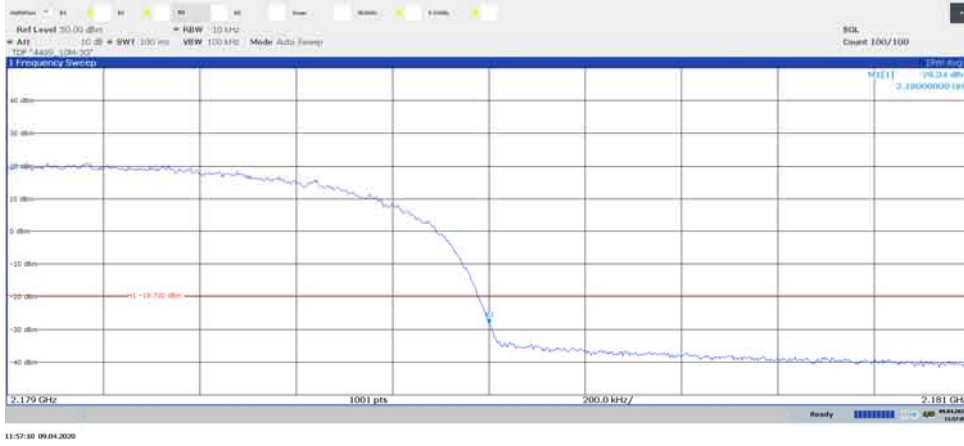


Diagram 2.26b, TM1, T, Port D:

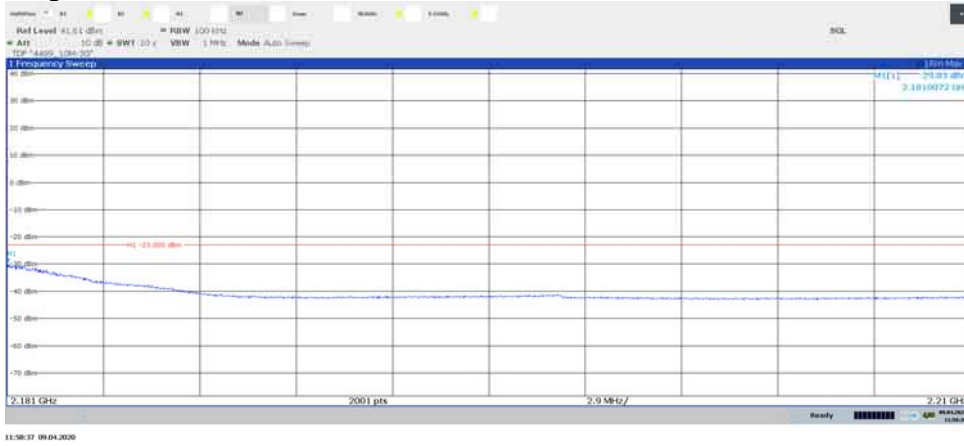


Diagram 2.27a, TM5, B, Port B:

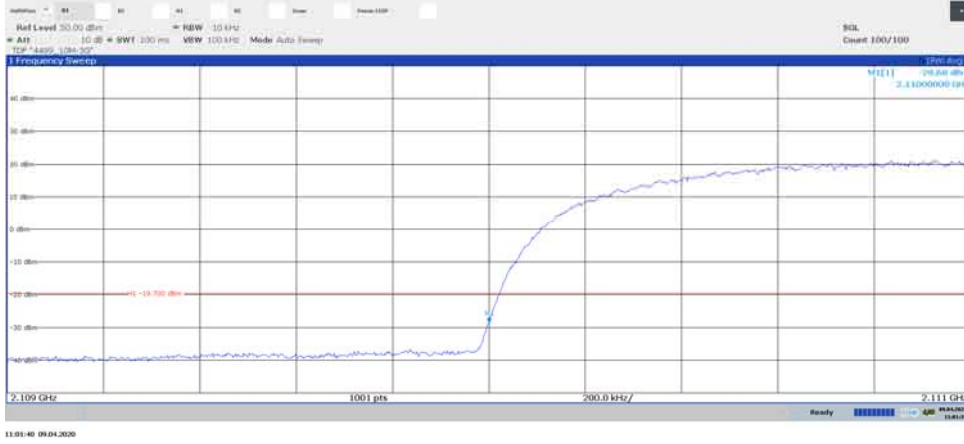


Diagram 2.27b, TM5, B, Port B:

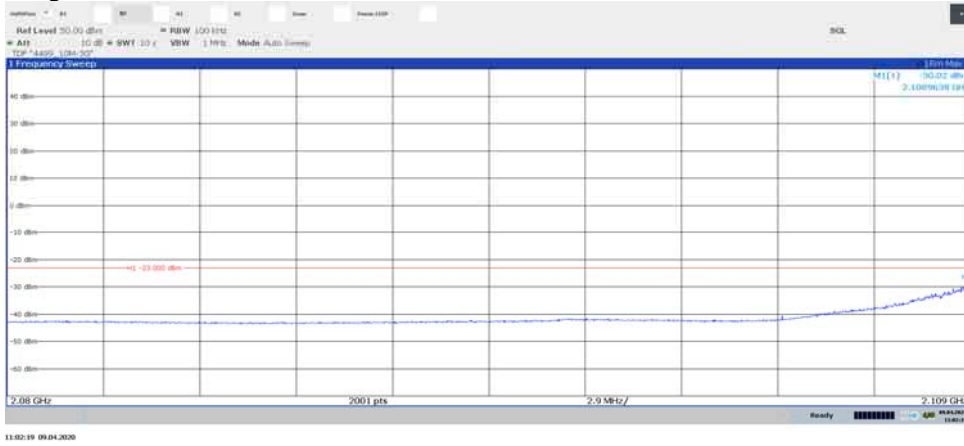


Diagram 2.28a, TM5, T, Port B:

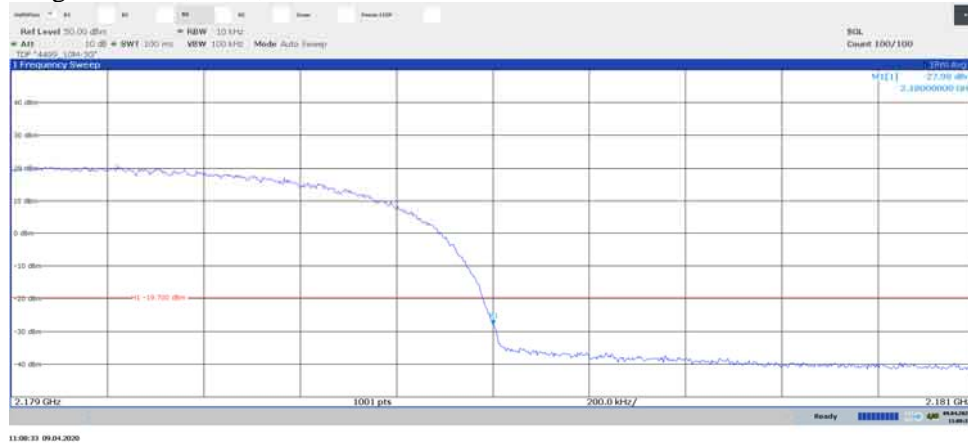


Diagram 2.28b, TM5, T, Port B:

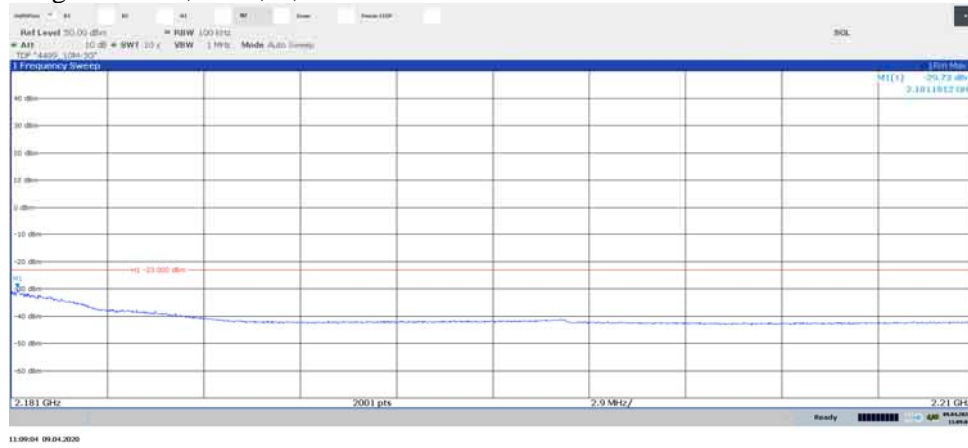


Diagram 2.29a, TM6, B, Port B:

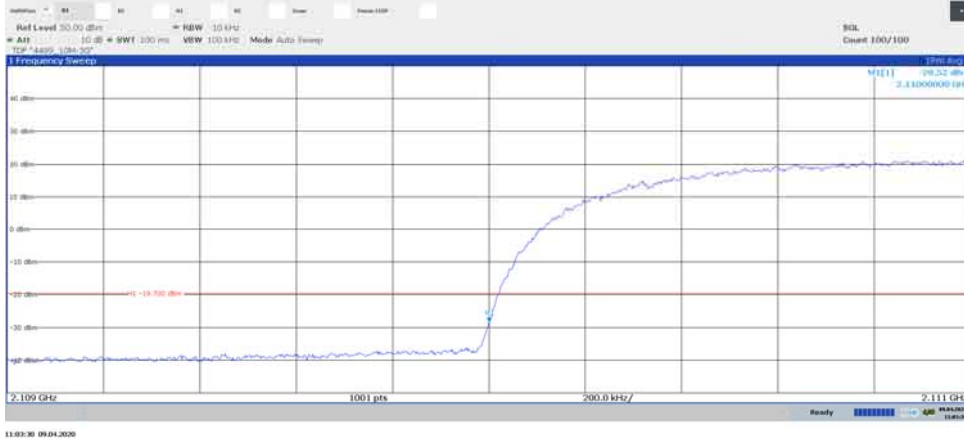


Diagram 2.29b, TM6, B, Port B:

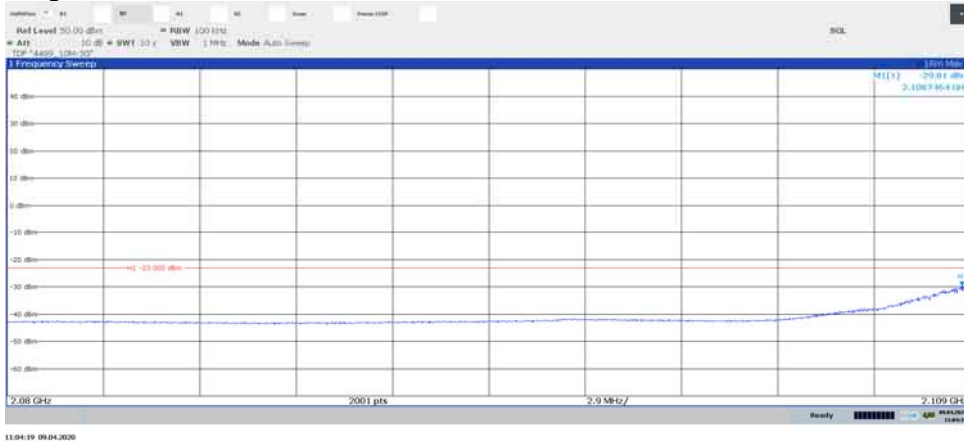


Diagram 2.30a, TM6, T, Port B:

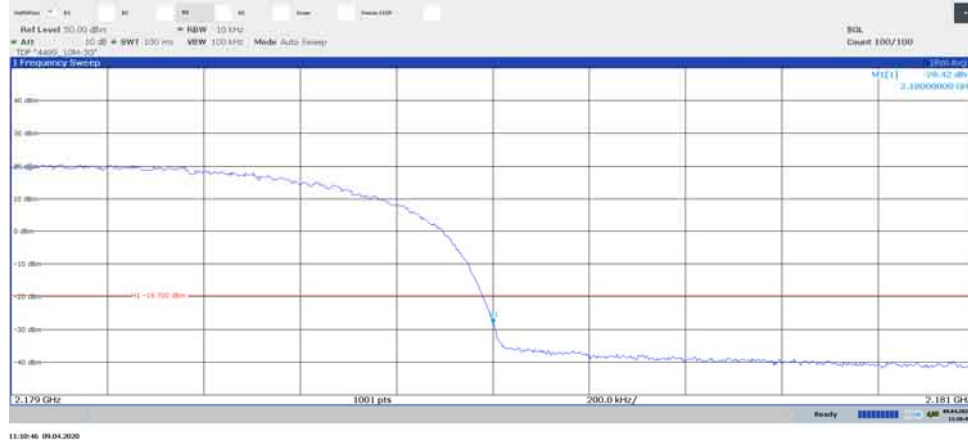


Diagram 2.30b, TM6, T, Port B:

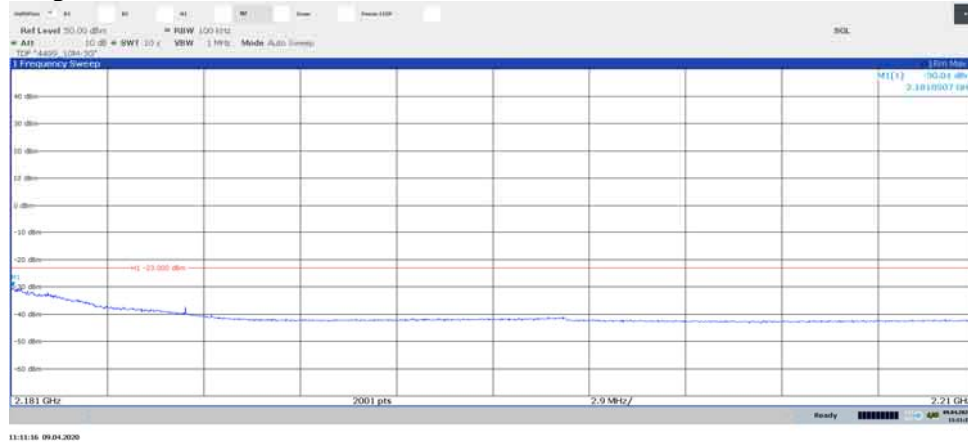


Diagram 2.31a, TM1, Bim, Port B:

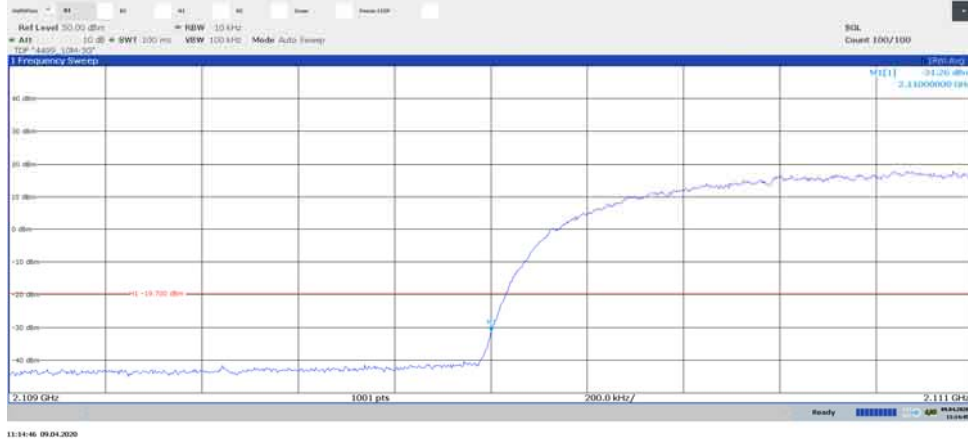


Diagram 2.31b, TM1, Bim, Port B:

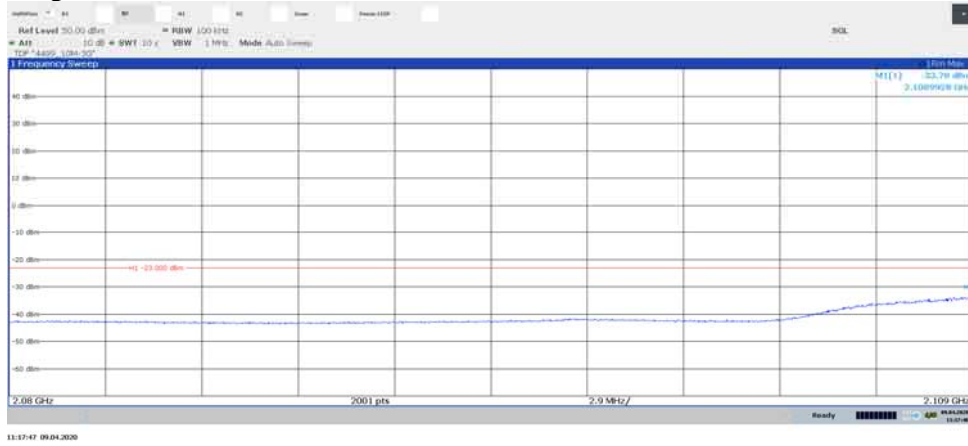


Diagram 2.32a, TM6, Tim, Port B:

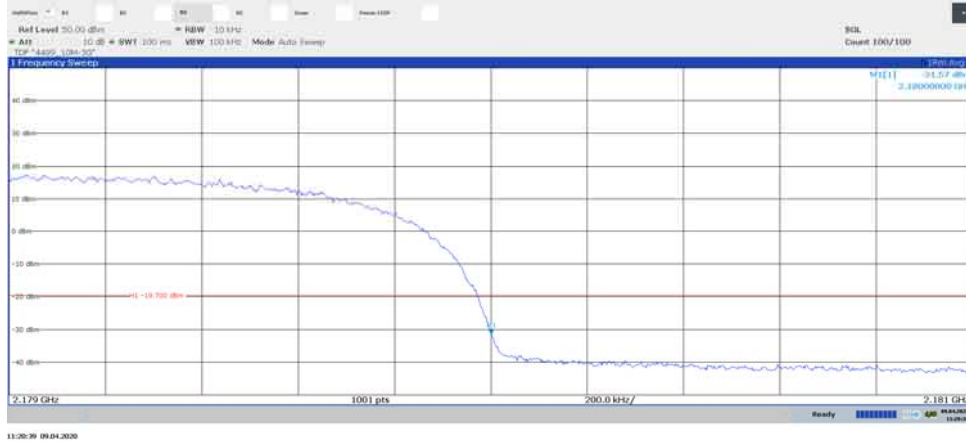


Diagram 2.32b, TM6, Tim, Port B:

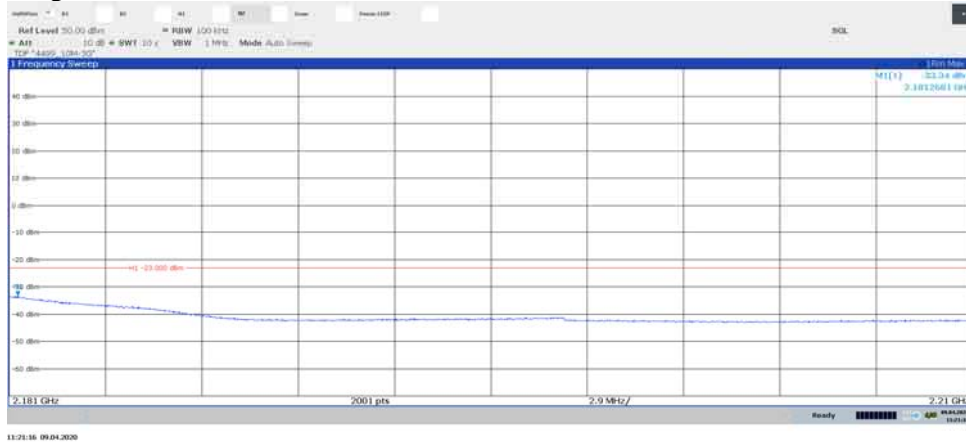


Diagram 2.33a, NB IoT SA: N-TM, WCDMA: TM1, Bim_{IoT+W}, Port A:

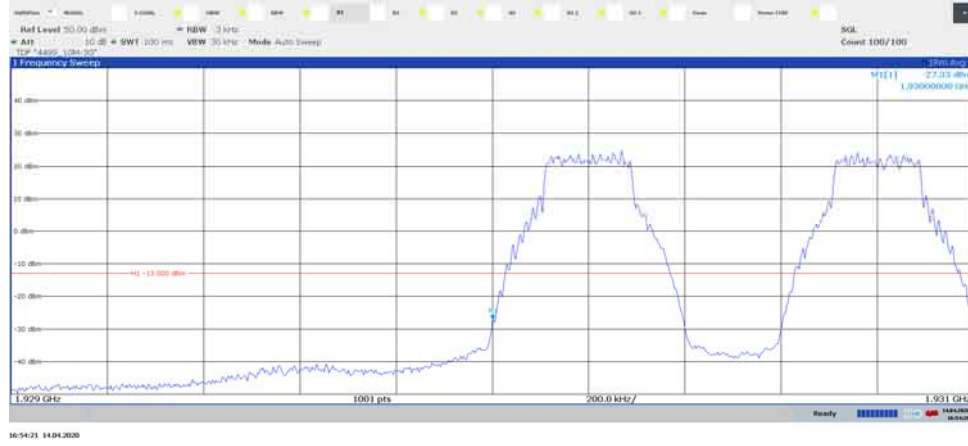


Diagram 2.33b, NB IoT SA: N-TM, WCDMA: TM1, Bim_{IoT+W}, Port A:

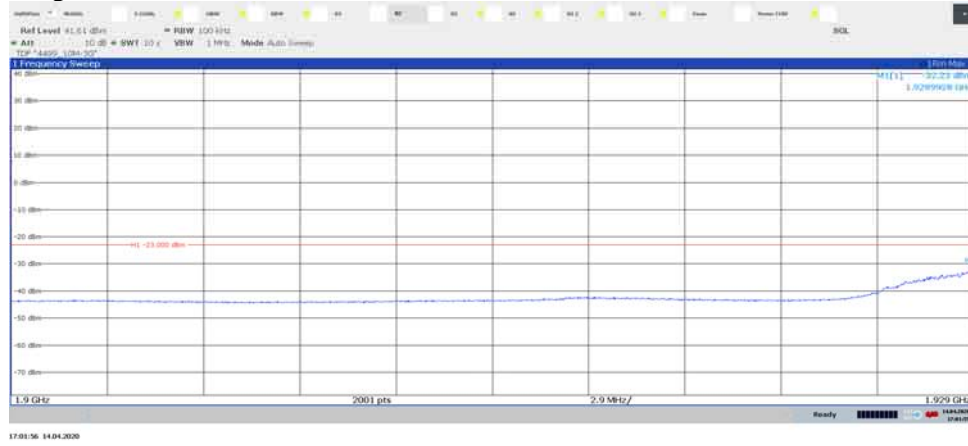


Diagram 2.34a, NB IoT SA: N-TM, WCDMA: TM1, $T_{imIoT+W}$, Port A:

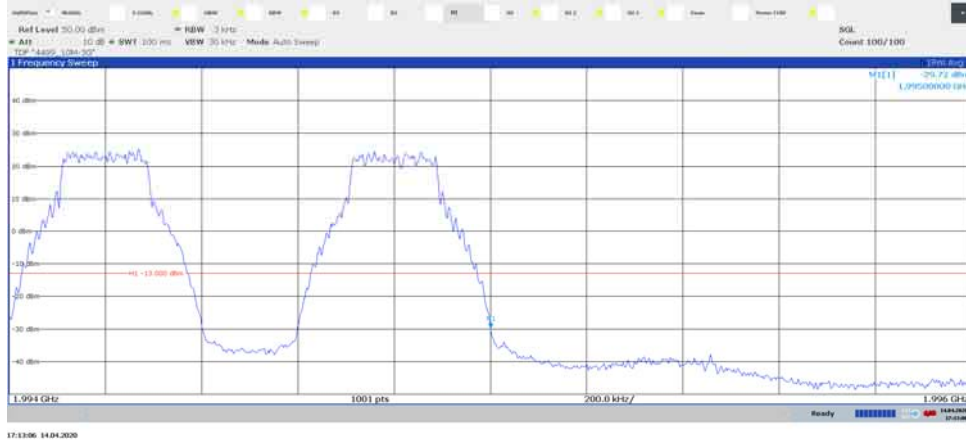


Diagram 2.34b, NB IoT SA: N-TM, WCDMA: TM1, $T_{imIoT+W}$, Port A:

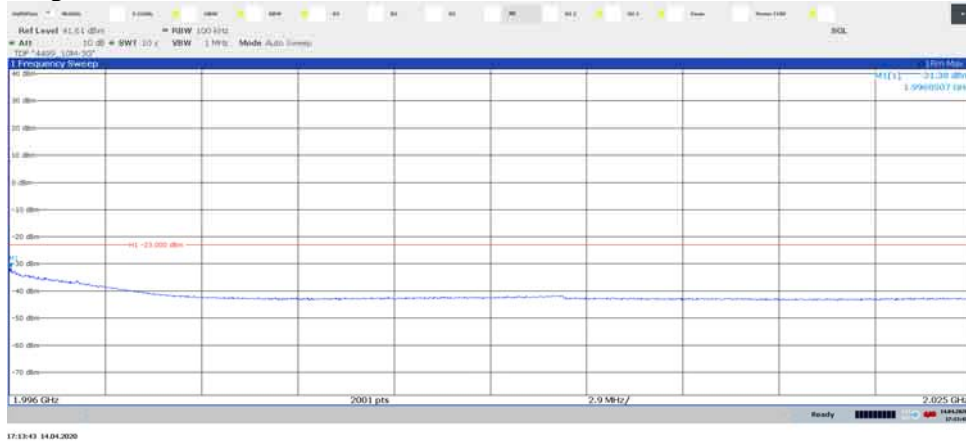


Diagram 2.35a, NB IoT SA: N-TM, WCDMA: TM1, Bim_{IoT+W}, Port B:

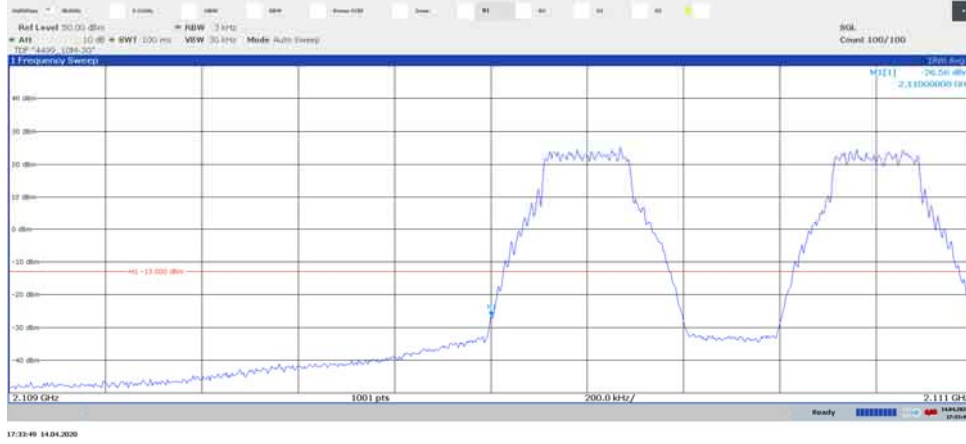


Diagram 2.35b, NB IoT SA: N-TM, WCDMA: TM1, Bim_{IoT+W}, Port B:

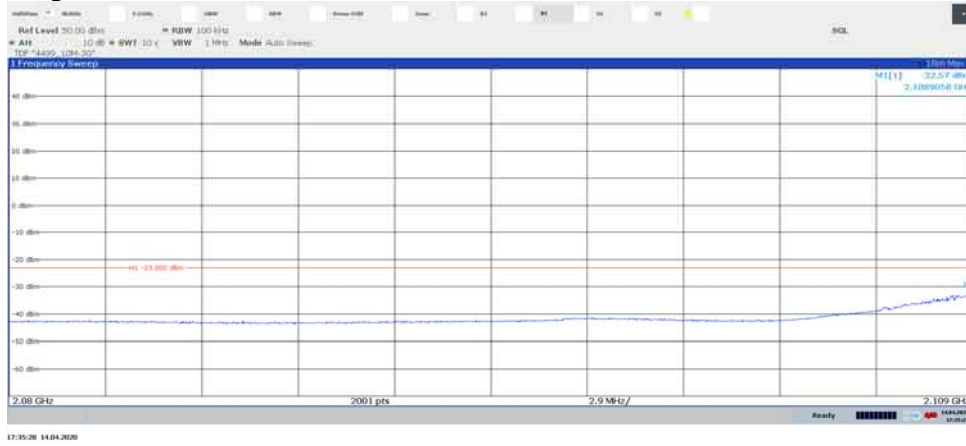


Diagram 2.36a, NB IoT SA: N-TM, WCDMA: TM1, $T_{imIoT+W}$, Port B:

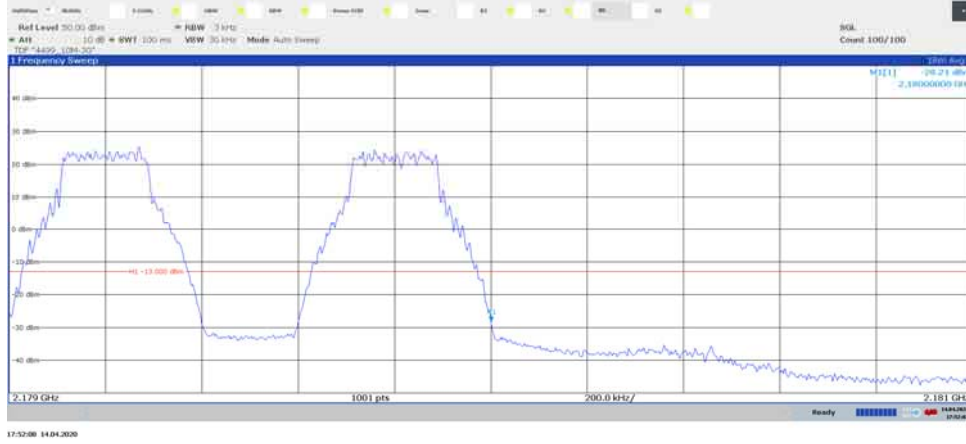


Diagram 2.36b, NB IoT SA: N-TM, WCDMA: TM1, $T_{imIoT+W}$, Port B:

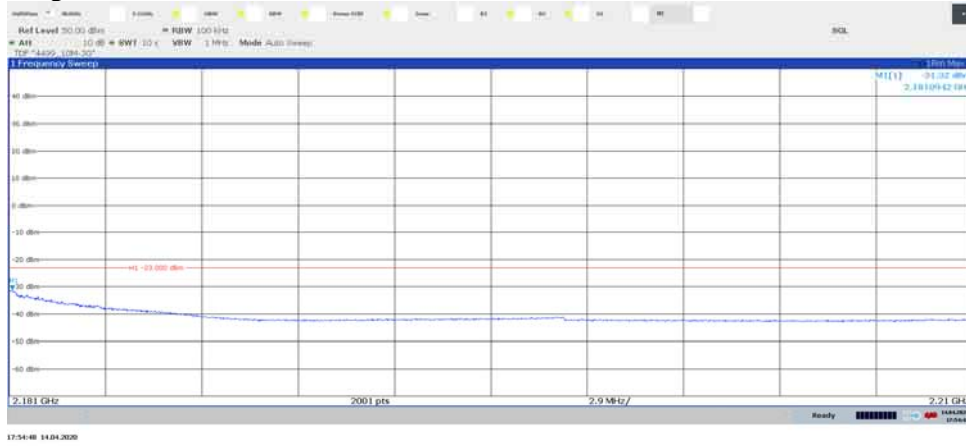


Diagram 2.37a, GSM: GMSK, NB IoT SA: N-TM, WCDMA: TM1, Bim_{G+IoT+W}, Port A:

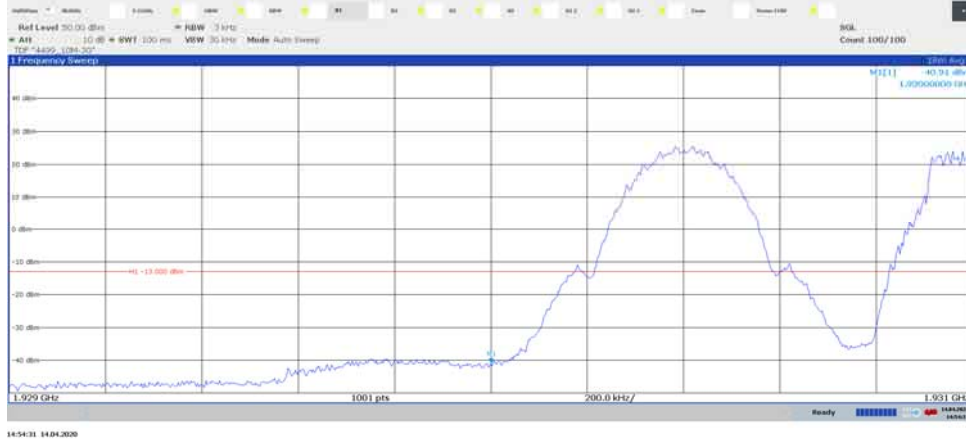


Diagram 2.37b, GSM: GMSK, NB IoT SA: N-TM, WCDMA: TM1, Bim_{G+IoT+W}, Port A:

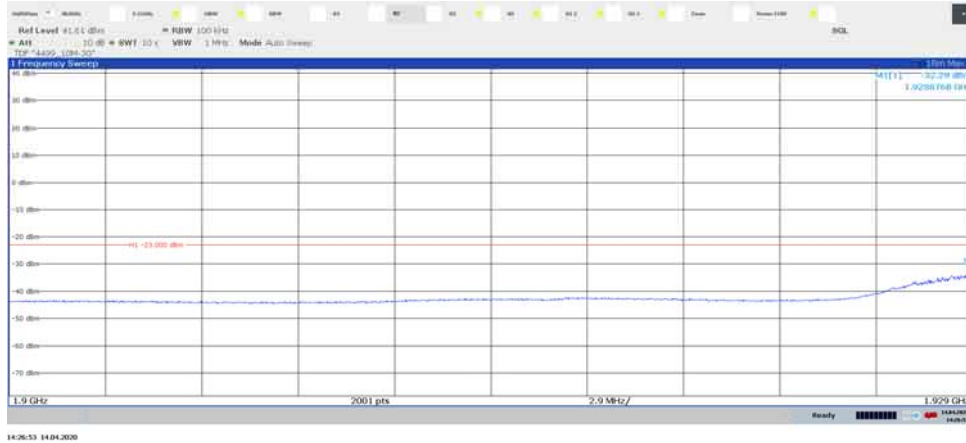


Diagram 2.38a, GSM: GMSK, NB IoT SA: N-TM, WCDMA: TM1, $T_{im_{G+IoT+W}}$, Port A:

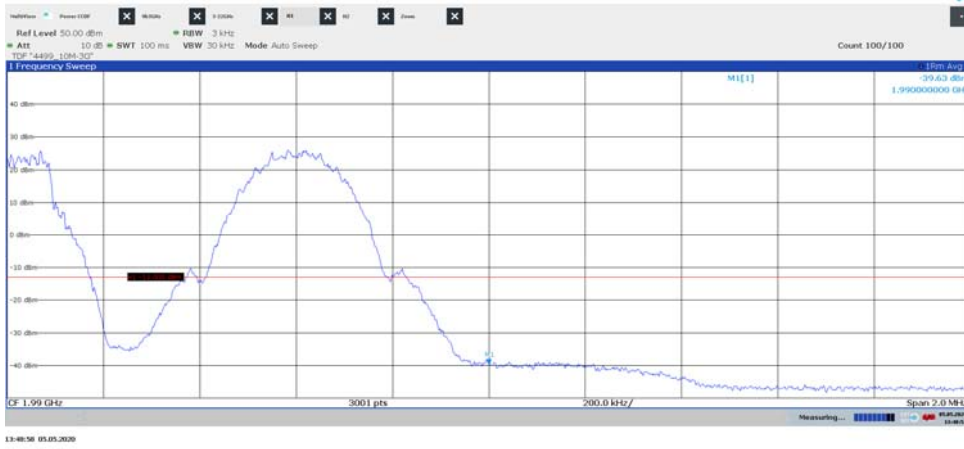
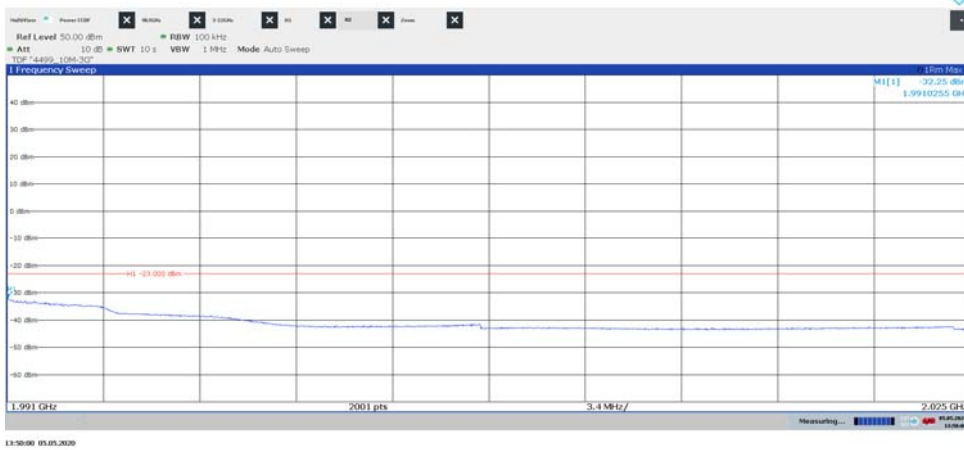


Diagram 2.38b, GSM: GMSK, NB IoT SA: N-TM, WCDMA: TM1, $T_{im_{G+IoT+W}}$, Port A:



Conducted spurious emission measurements according to CFR 47 §24.238 and §27.53(h) / RSS-133 6.5, RSS-139 6.6

Date	Temperature	Humidity
2020-04-06	24 °C ± 3 °C	15 % ± 5 %
2020-04-08	22 °C ± 3 °C	15 % ± 5 %
2020-04-09	22 °C ± 3 °C	13 % ± 5 %
2020-04-14	22 °C ± 3 °C	10 % ± 5 %
2020-05-05	22 °C ± 3 °C	14 % ± 5 %

Test set-up and procedure

The measurements were made per definition in ANSI C63.26, 5.7.4. The output was connected to a spectrum analyzer with the RMS detector activated.

Before comparing the results to the limit, 6 dB [10 log (4)] to cover 4x4 MIMO, should be added according to ANSI C63.26 6.4.4.1 c “measure and add 10 log(N_{ANT})”.

Measurement equipment	RISE number
R&S FSW 43	902 073
Directional coupler	901 496
RF attenuator	902 282
High pass filter 3-27 GHz	901 502
Coaxial cable Megaphase	BX50191
Coaxial cable Sucoflex 102EA	BX50236
Coaxial cable Sucoflex 102EA	BX50237
Testo 635, temperature and humidity meter	504 203

Measurement uncertainty: 3.7 dB

Results WCDMA

B25 max power configuration:

Single carrier TM1

Diagram	Symbolic name	Tested Port
3.1 a-b	B	RF A
3.2 a-b	M	RF A
3.3 a-b	T	RF A
3.4 a-b	T	RF B
3.5 a-b	T	RF C
3.6 a-b	T	RF D

Multi carrier TM1

Diagram	Symbolic name	Tested Port
3.7 a-c	Bim	RF A
3.8 a-c	Tim	RF A
3.9 a-c	M6	RF A

B66 max power configuration:

Single carrier TM1

Diagram	Symbolic name	Tested Port
3.10 a-b	B	RF A
3.11 a-b	B	RF B
3.12 a-b	B	RF C
3.13 a-b	B	RF D
3.14 a-b	M	RF B
3.15 a-b	T	RF B

Multi carrier TM1

Diagram	Symbolic name	Tested Port
3.16 a-c	Bim	RF B
3.17 a-c	Tim	RF B
3.18 a-c	M6	RF B

Note: Measurements were mainly limited to port RF B due to the measurement result in single carrier mode that shows that the ports are electrical identical as declared by the client.

Results WCDMA+NB IoT SA

B25 max power configuration:

Multi RAT: NB IoT SA: N-TM, WCDMA: TM1

Diagram	Symbolic name	Tested Port
3.19 a-c	$B_{im_{IoT+W}}$	RF A
3.20 a-c	$T_{im_{IoT+W}}$	RF A

B66 max power configuration:

Multi RAT: NB IoT SA: N-TM, WCDMA: TM1

Diagram	Symbolic name	Tested Port
3.21 a-c	$B_{im_{IoT+W}}$	RF B
3.22 a-c	$T_{im_{IoT+W}}$	RF B

Results WCDMA+GSM+NB IoT SA

B2 max power configuration:

Multi RAT: GSM: GMSK, NB IoT SA: N-TM, WCDMA: TM1

Diagram	Symbolic name	Tested Port
3.23 a-c	$B_{im_{G+IoT+W}}$	RF A
3.24 a-c	$T_{im_{G+IoT+W}}$	RF A
3.25 a-c	$Ma_{X_{G+IoT+W}}$	RF A

Remark

The emission at 9 kHz on the plots was not generated by the test object. A complementary measurement with a smaller RBW showed that it was related to the LO feed-through.

The highest fundamental frequency is 2180 MHz. The measurements were made up to 22 GHz (10x2180 MHz = 21.80 GHz).

Limits

CFR 47 §24.238, §27.53(h) and RSS-133 6.5, RSS-139 6.6

- i. In the 1.0 MHz bands immediately outside and adjacent to the equipment's operating frequency block, the emission power per any 1% of the emission bandwidth shall be attenuated (in dB) below the transmitter output power P (dBW) by at least $43 + 10 \log_{10}(\text{watts})$.
- ii. After the first 1.0 MHz, the emission power in any 1 MHz bandwidth shall be attenuated (in dB) below the transmitter output power P (dBW) by at least $43 + 10 \log_{10}(\text{watts})$. If the measurement is performed using 1% of the emission bandwidth, power integration over 1.0 MHz is required.

Complies?	Yes
-----------	-----

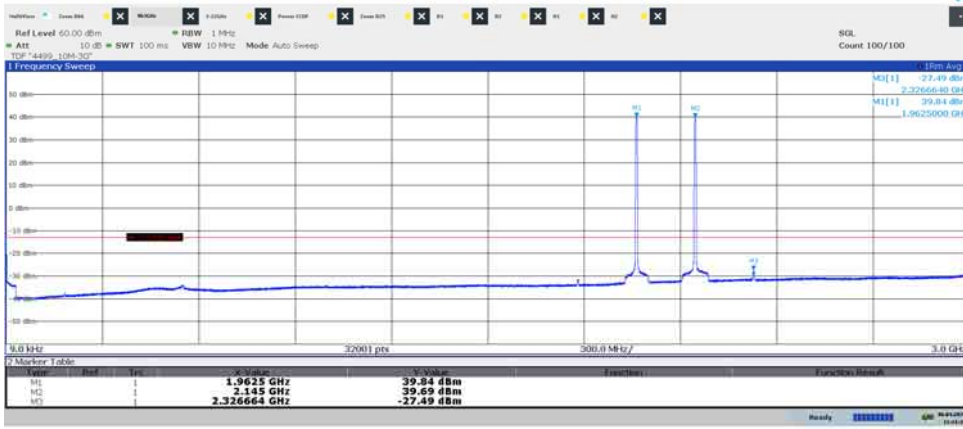
Diagram 3.1a, TM1, B, 9 kHz – 3 GHz, Port A:



Diagram 3.1b, TM1, B, 3 GHz – 22 GHz, Port A:

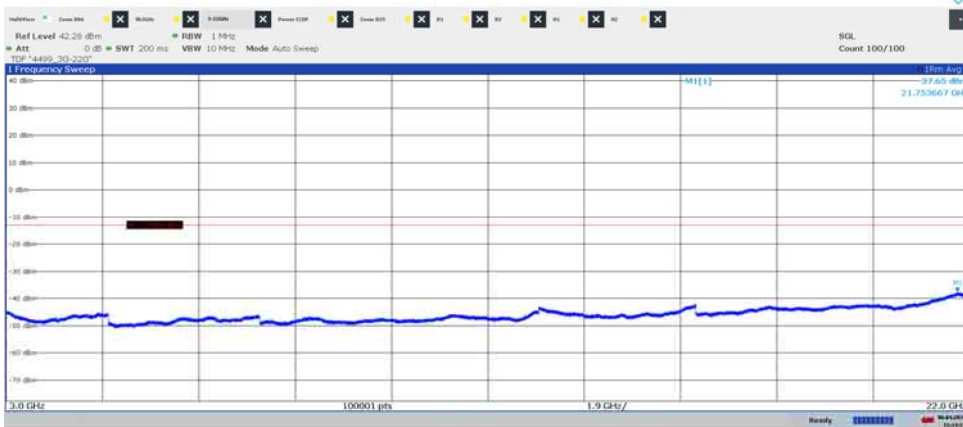


Diagram 3.2a, TM1, M, 9 kHz – 3 GHz, Port A:



11:11:10 06.04.2020

Diagram 3.2b, TM1, M, 3 GHz – 22 GHz, Port A:



11:14:34 06.04.2020

Diagram 3.3a, TM1, T, 9 kHz – 3 GHz, Port A:

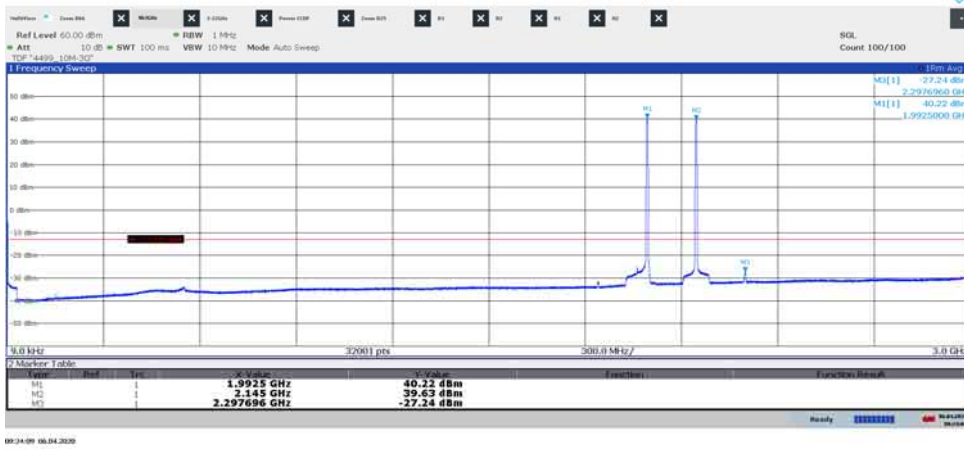


Diagram 3.3b, TM1, T, 3 GHz – 22 GHz, Port A:

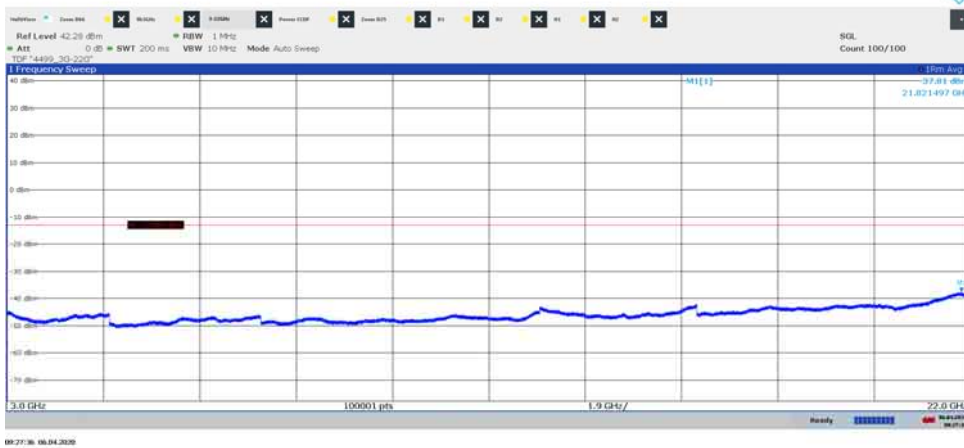


Diagram 3.4a, TM1, T, 9 kHz – 3 GHz, Port B:

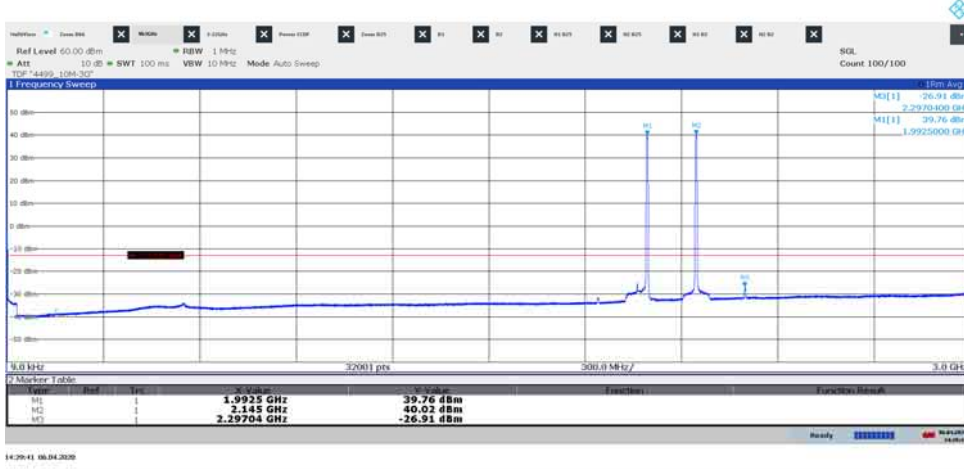


Diagram 3.4b, TM1, T, 3 GHz – 22 GHz, Port B:

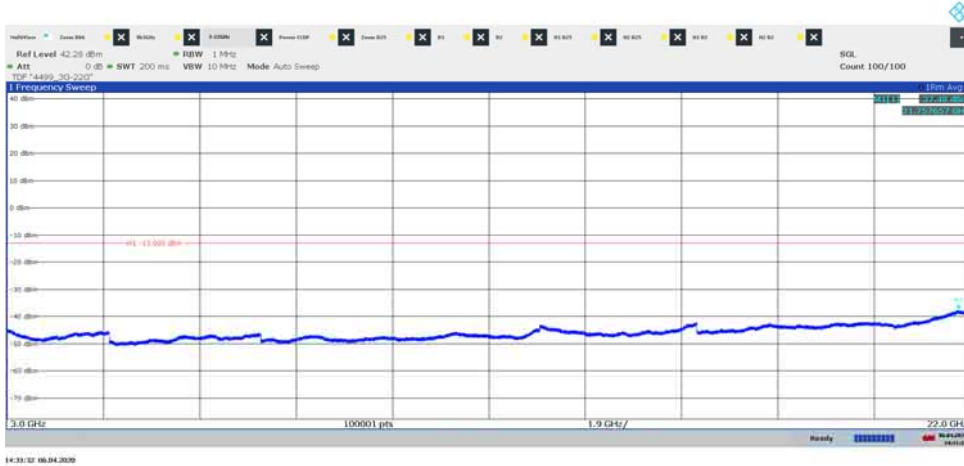


Diagram 3.5a, TM1, T, 9 kHz – 3 GHz, Port C:

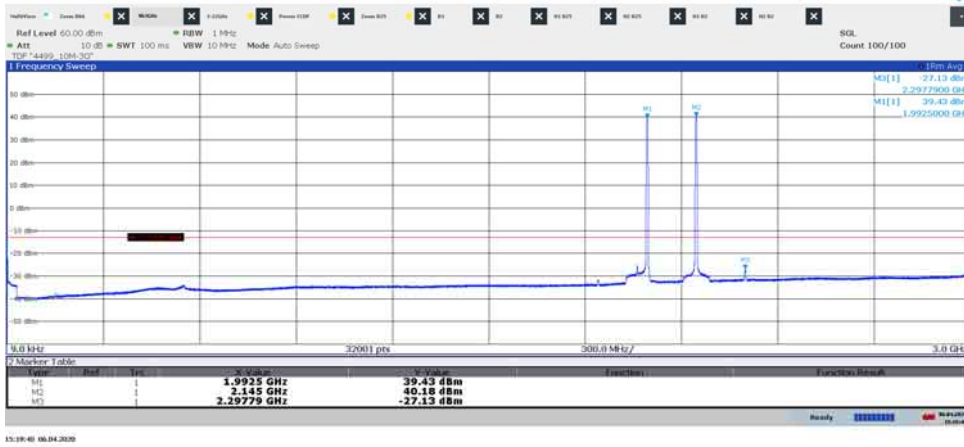


Diagram 3.5b, TM1, T, 3 GHz – 22 GHz, Port C:

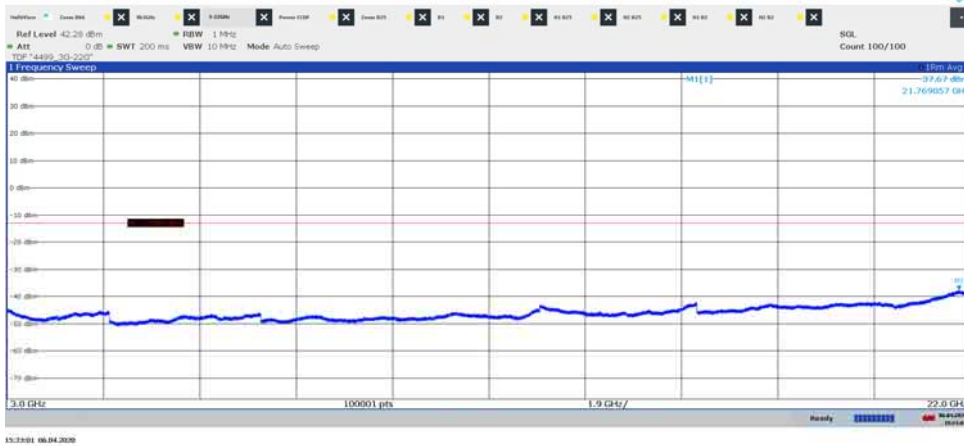


Diagram 3.6a, TM1, T, 9 kHz – 3 GHz, Port D:

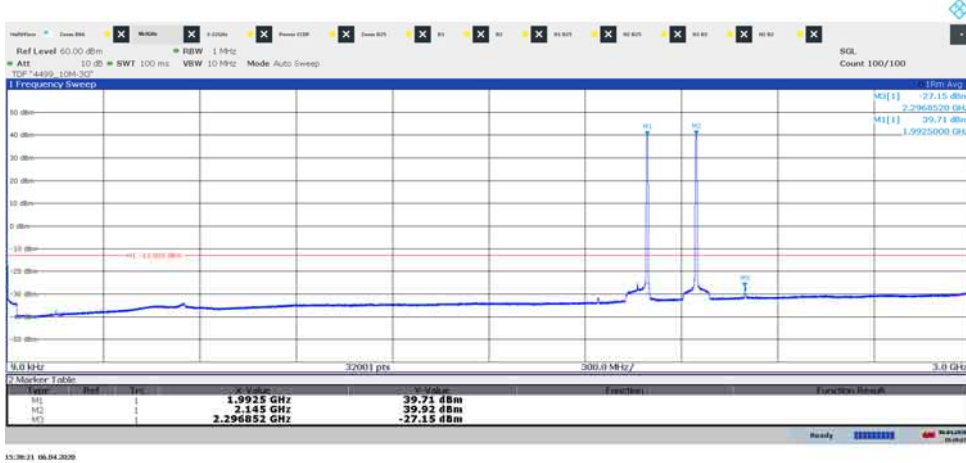


Diagram 3.6b, TM1, T, 3 GHz – 22 GHz, Port D:



Diagram 3.7a, TM1, Bim, 9 kHz – 3 GHz, Port A:



Diagram 3.7b, TM1, Bim, 1.8875 GHz – 2.0375 GHz, Port A:



Diagram 3.7c, TM1, Bim, 3 GHz – 22 GHz, Port A:

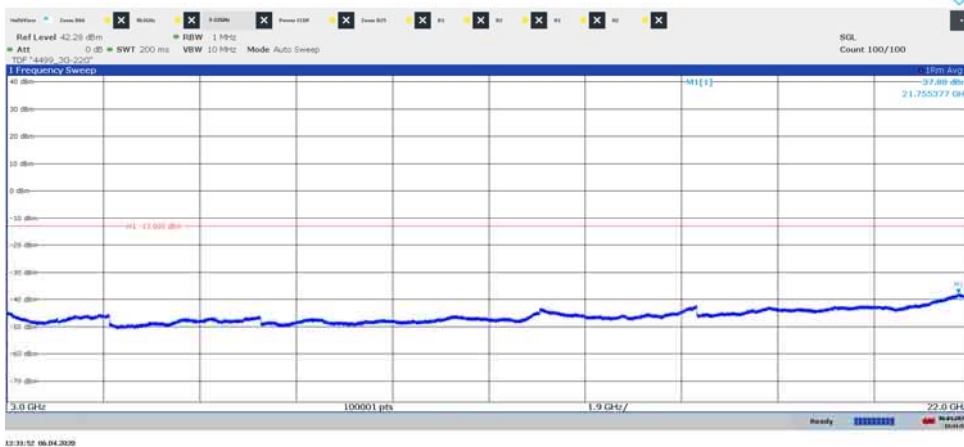


Diagram 3.8a, TM1, Tim, 9 kHz – 3 GHz, Port A:

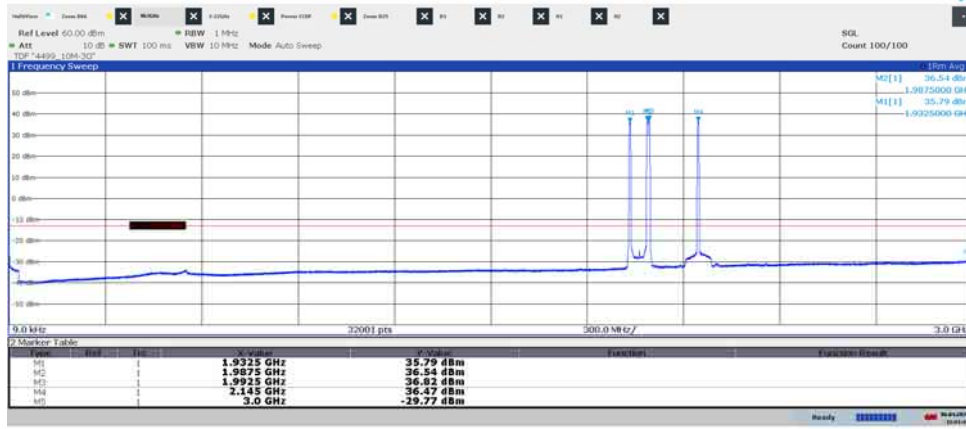


Diagram 3.8b, TM1, Tim, 1.8875 GHz – 2.0375 GHz, Port A:



Diagram 3.8c, TM1, Tim, 3 GHz – 22 GHz, Port A:

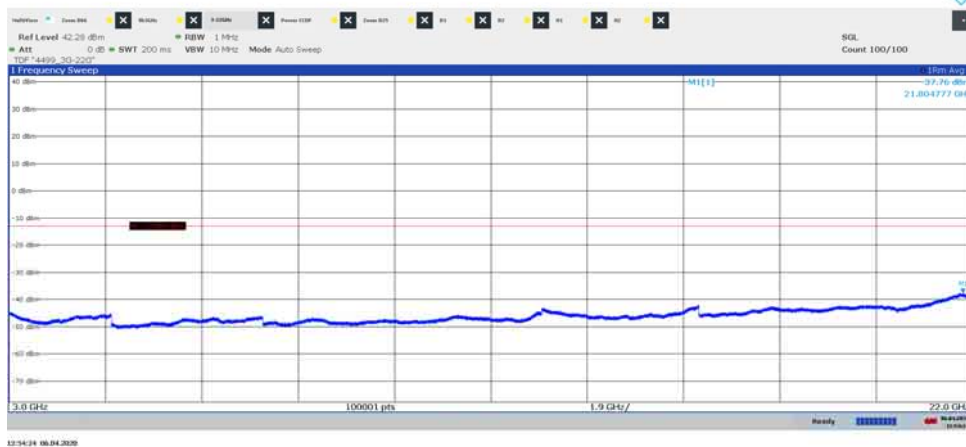


Diagram 3.9a, TM1, M6, 9 kHz – 3 GHz, Port A:

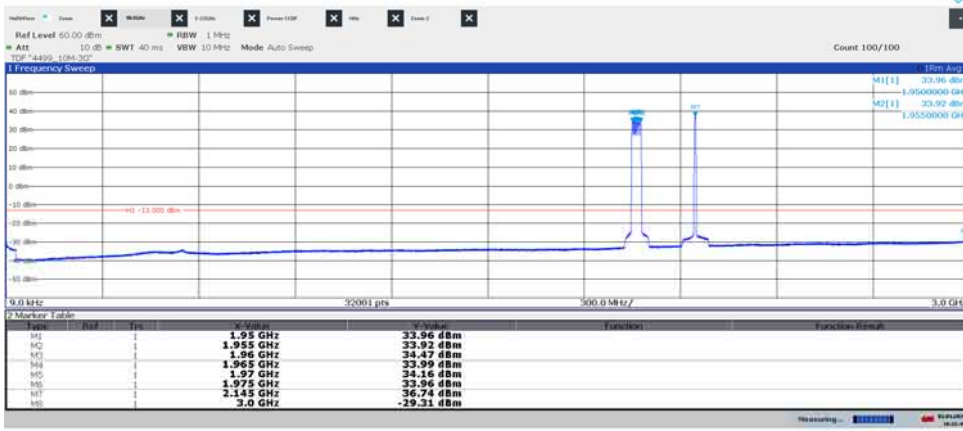


Diagram 3.9b, TM1, M6, 1.8875 GHz – 2.0375 GHz, Port A:

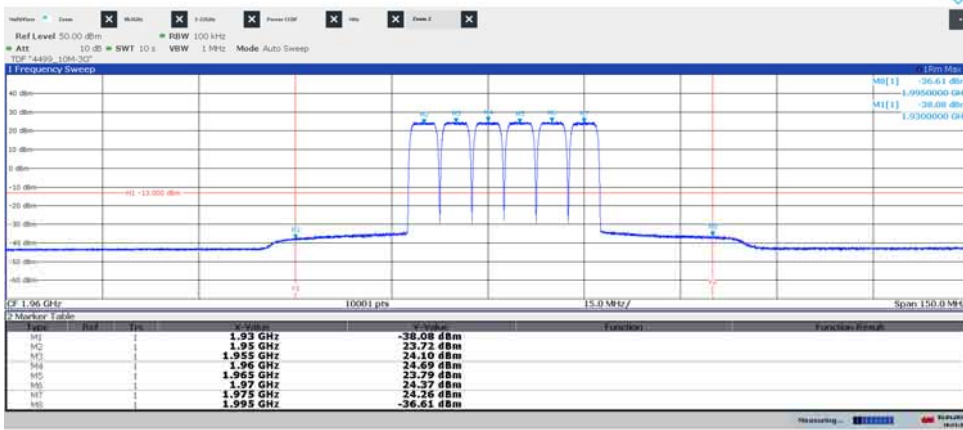


Diagram 3.9c, TM1, M6, 3 GHz – 22 GHz, Port A:

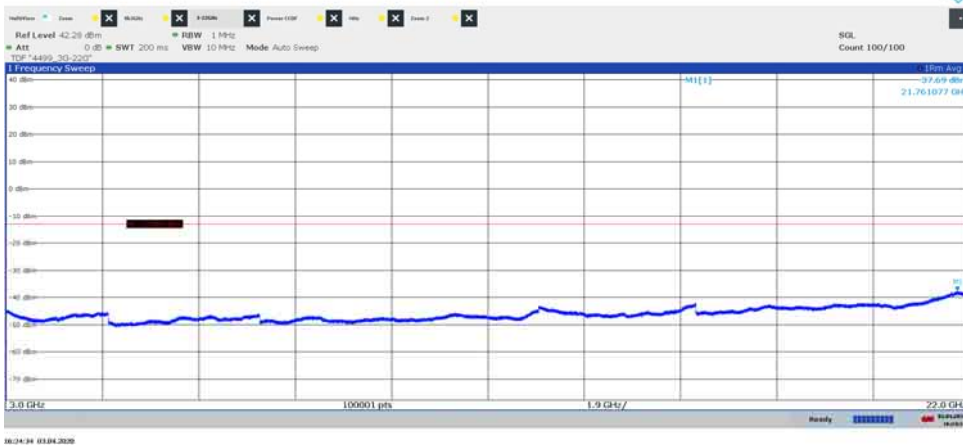


Diagram 3.10a, TM1, B, 9 kHz – 3 GHz, Port A:

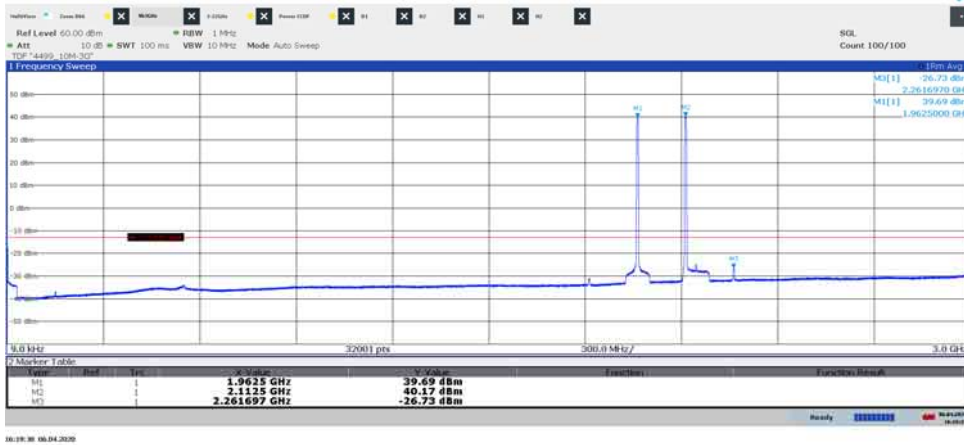


Diagram 3.10b, TM1, B, 3 GHz – 22 GHz, Port A:

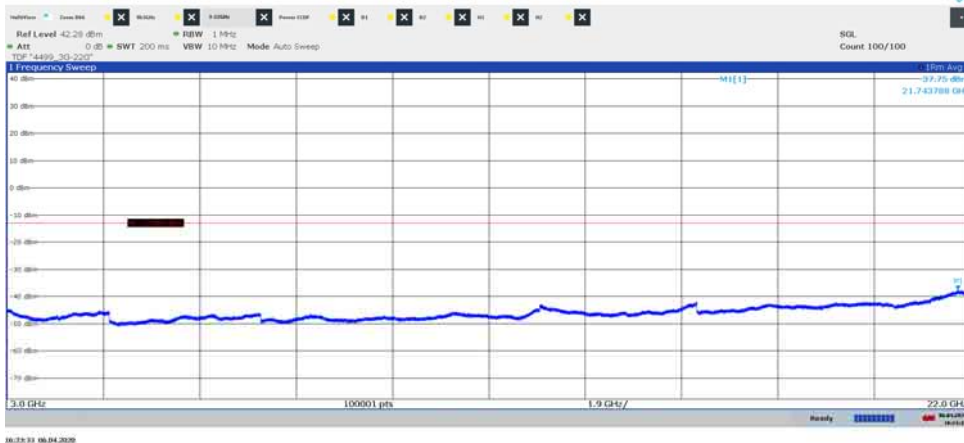


Diagram 3.11a, TM1, B, 9 kHz – 3 GHz, Port B:

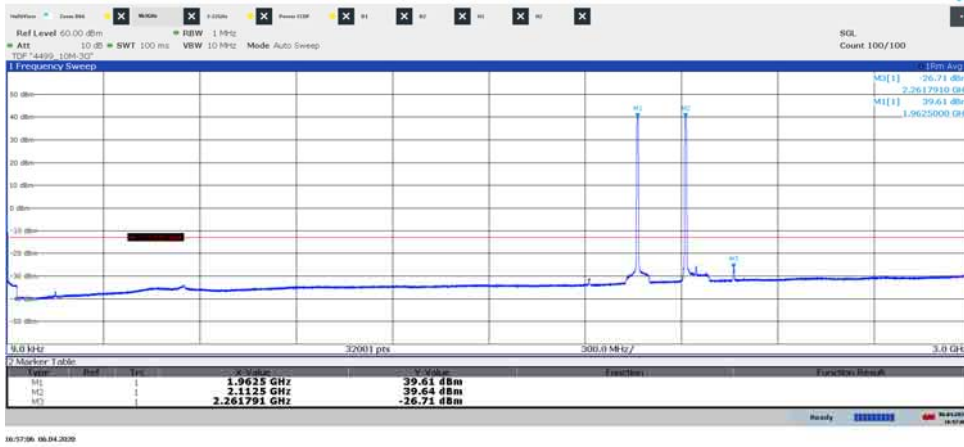


Diagram 3.11b, TM1, B, 3 GHz – 22 GHz, Port B:

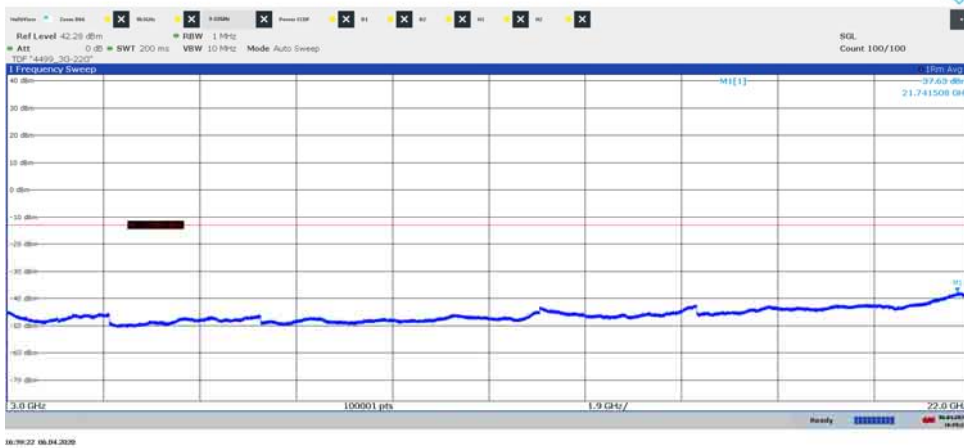


Diagram 3.12a, TM1, B, 9 kHz – 3 GHz, Port C:

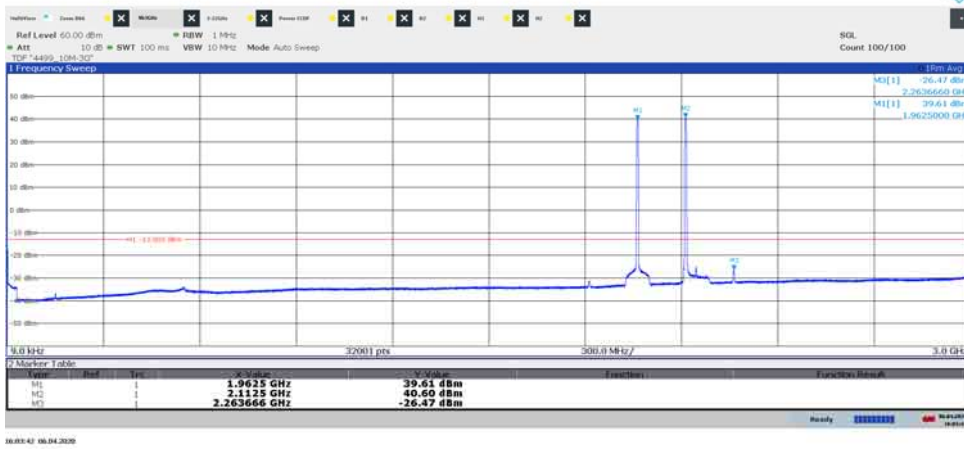


Diagram 3.12b, TM1, B, 3 GHz – 22 GHz, Port C:

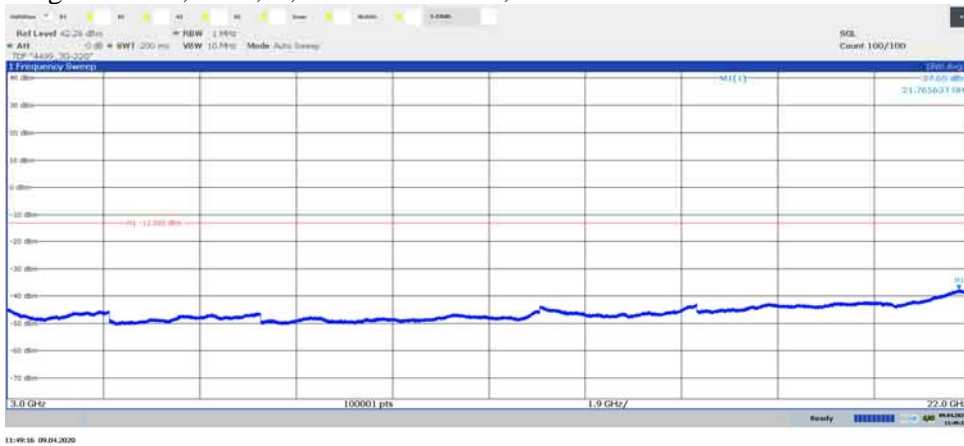


Diagram 3.13a, TM1, B, 9 kHz – 3 GHz, Port D:

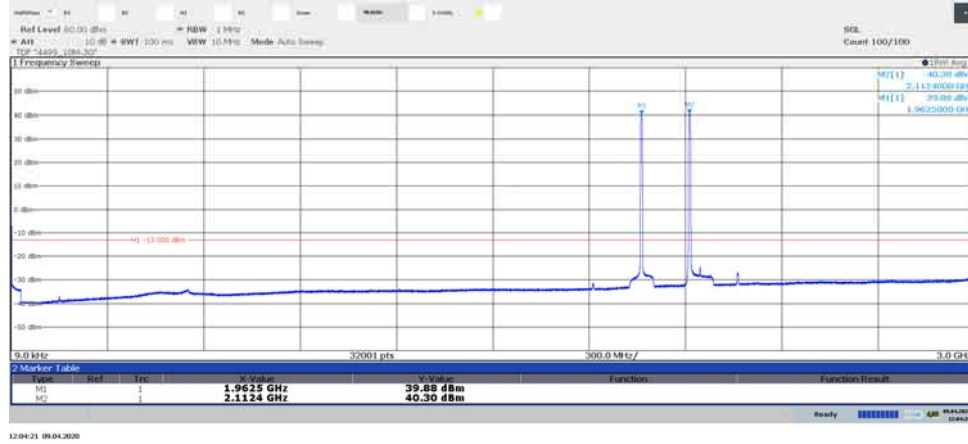


Diagram 3.13b, TM1, B, 3 GHz – 22 GHz, Port D:

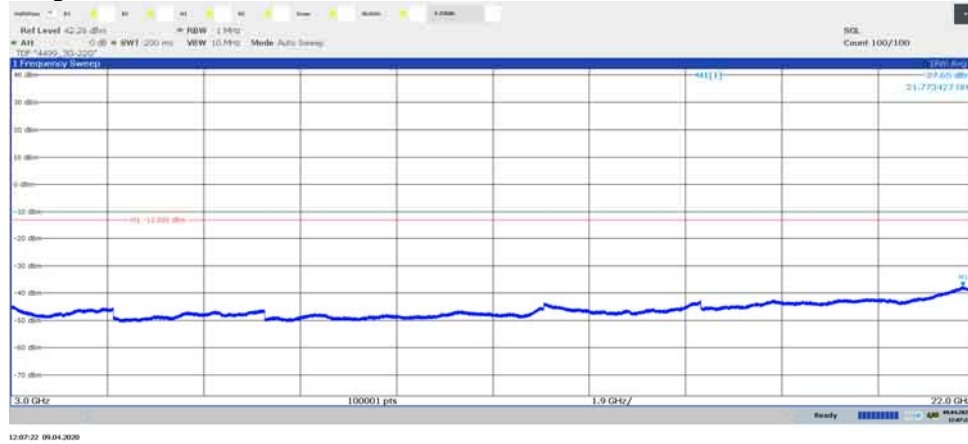
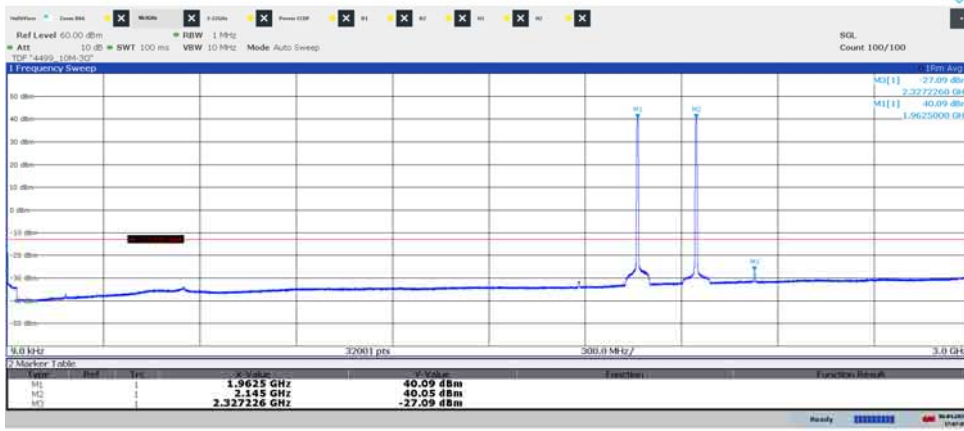
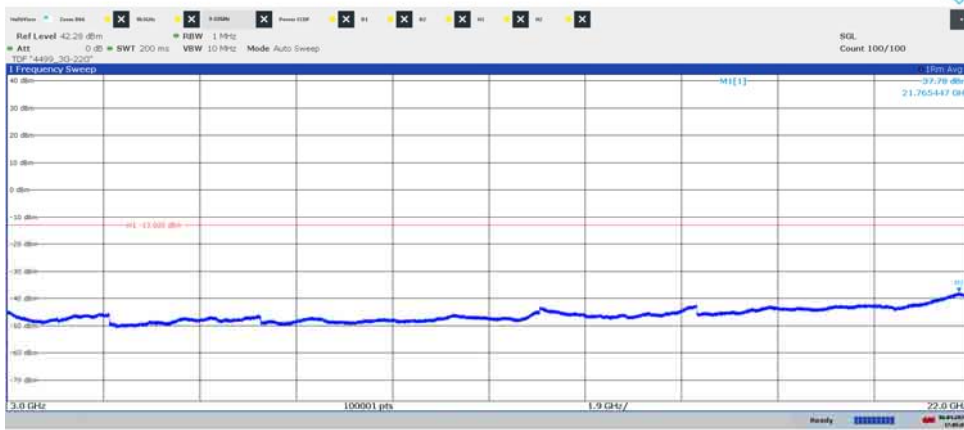


Diagram 3.14a, TM1, M, 9 kHz – 3 GHz, Port B:



11:07:05 06.04.2020

Diagram 3.14b, TM1, M, 3 GHz – 22 GHz, Port B:



11:05:05 06.04.2020

Diagram 3.15a, TM1, T, 9 kHz – 3 GHz, Port B:

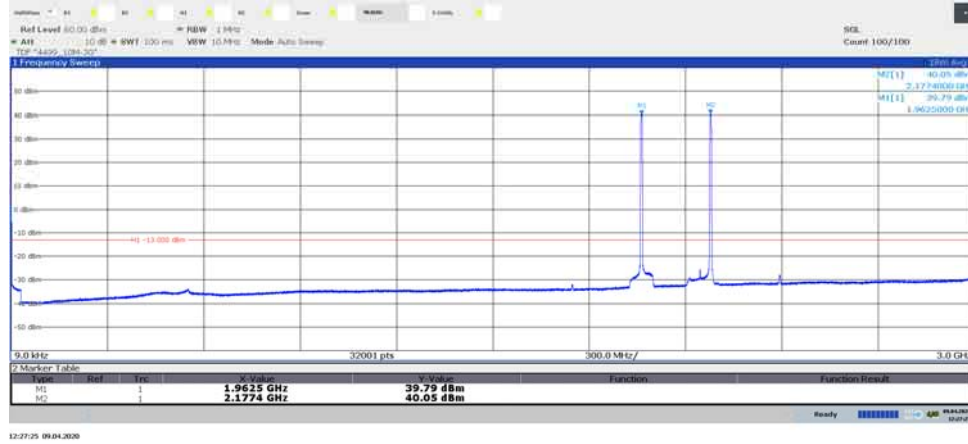


Diagram 3.15b, TM1, T, 3 GHz – 22 GHz, Port B:

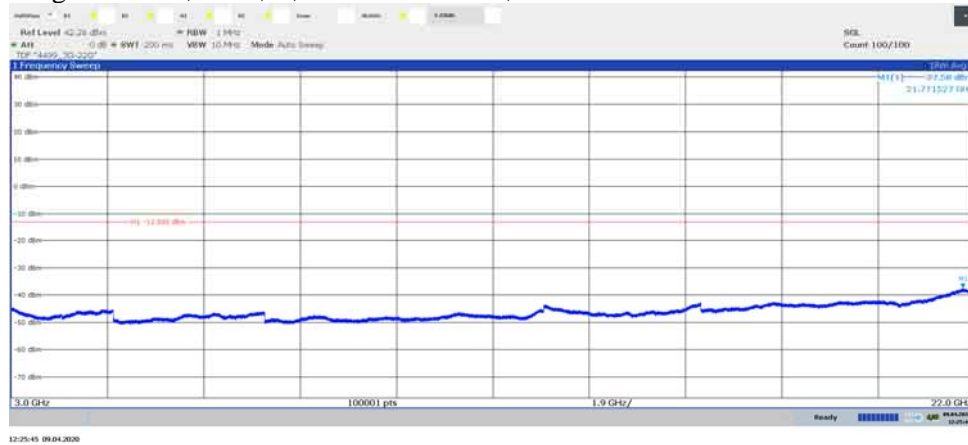


Diagram 3.16a, TM1, Bim, 9 kHz – 3 GHz, Port B:

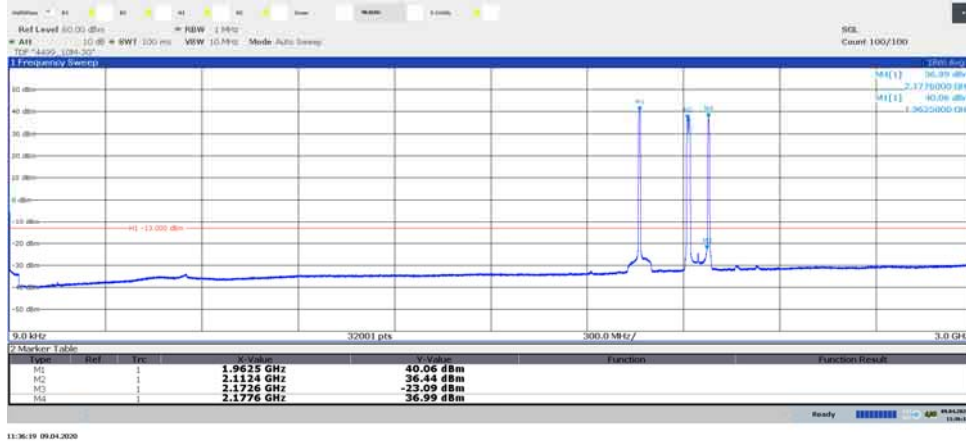
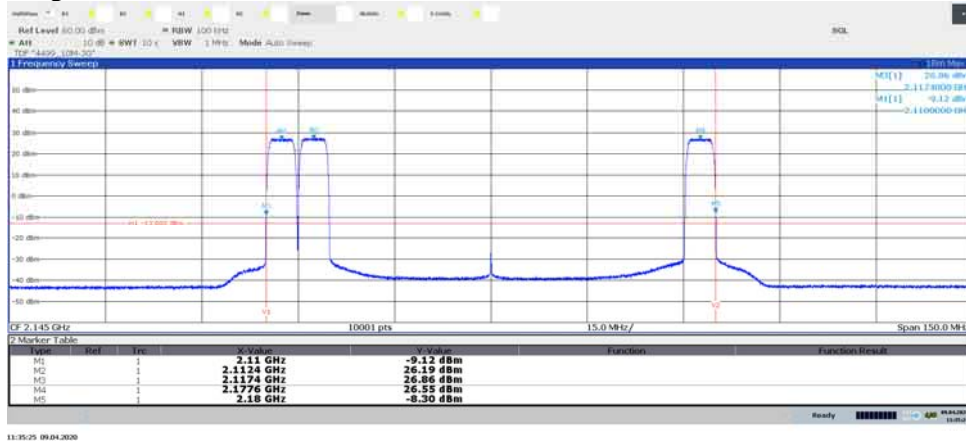


Diagram 3.16b, TM1, Bim, 1.8875 GHz – 2.0375 GHz, Port B:



Note: The purpose of this measurement is to find IM products, not to verify compliance at the edges.

Diagram 3.16c, TM1, Bim, 3 GHz – 22 GHz, Port B:

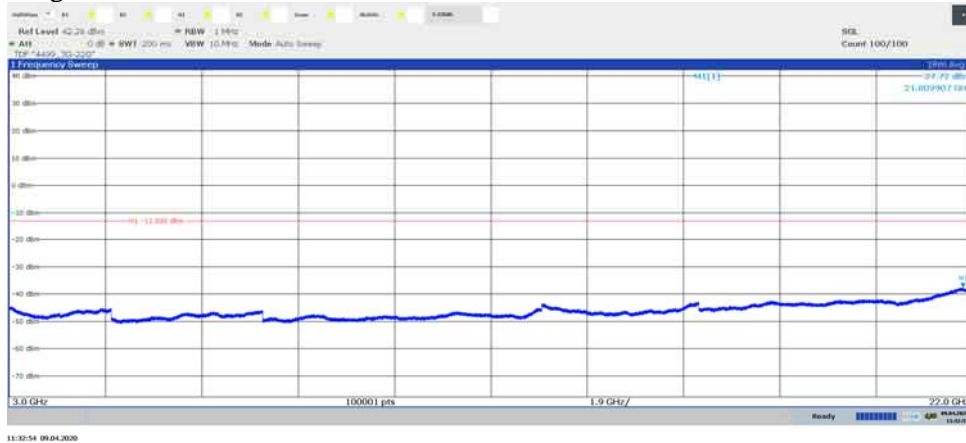


Diagram 3.17a, TM1, Tim, 9 kHz – 3 GHz, Port B:

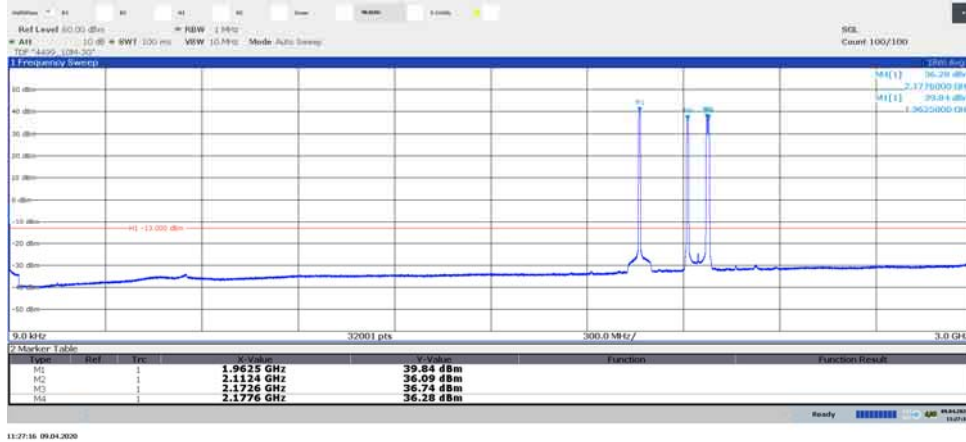
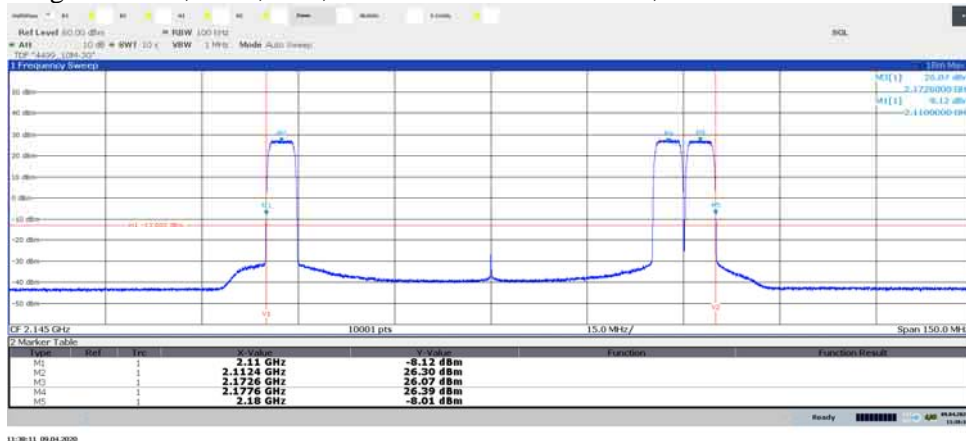


Diagram 3.17b, TM1, Tim, 1.8875 GHz – 2.0375 GHz, Port B:



Note: The purpose of this measurement is to find IM products, not to verify compliance at the edges.

Diagram 3.17c, TM1, Tim, 3 GHz – 22 GHz, Port B:

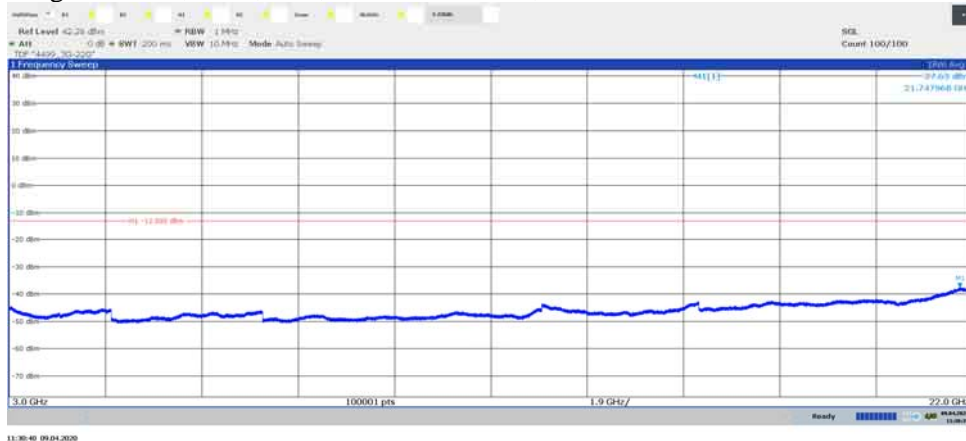
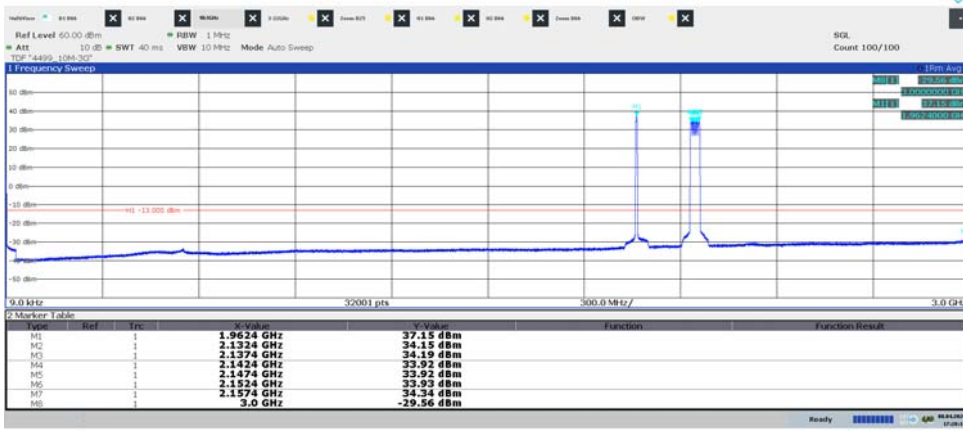
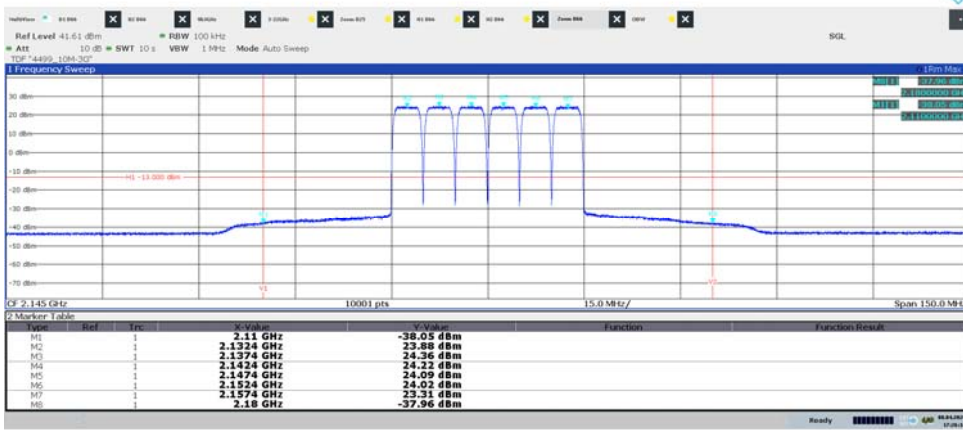


Diagram 3.18a, TM1, M6, 9 kHz – 3 GHz, Port B:



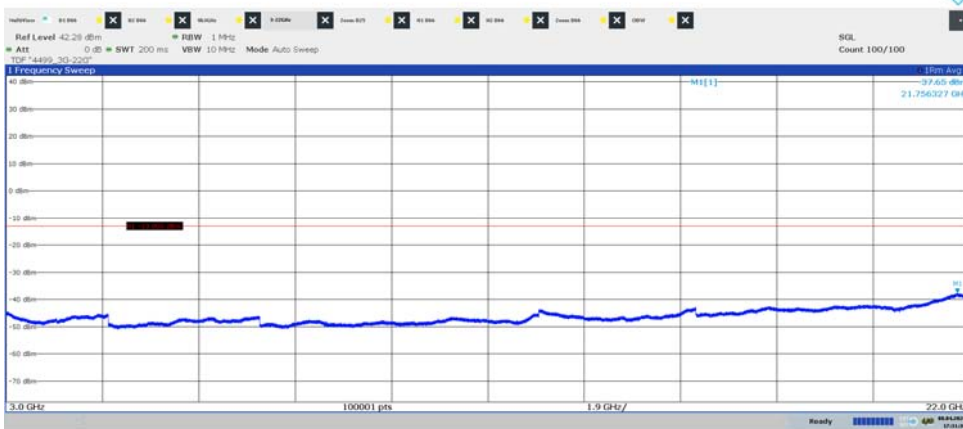
17:26:13 08.04.2020

Diagram 3.18b, TM1, M6, 1.8875 GHz – 2.0375 GHz, Port B:



17:26:18 08.04.2020

Diagram 3.18c, TM1, M6, 3 GHz – 22 GHz, Port B:



17:31:36 08.04.2020

Diagram 3.19a, NB IoT SA: N-TM, WCDMA: TM1, Bim_{IoT+W}, 9 kHz – 3 GHz, Port A:

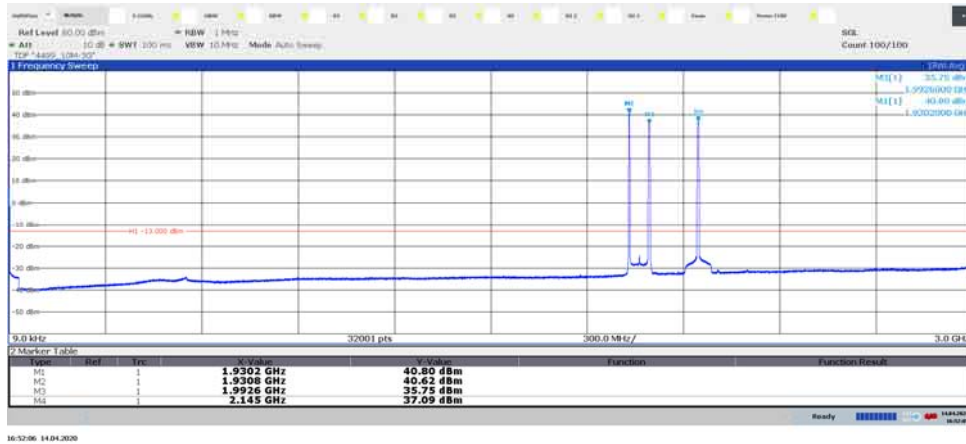
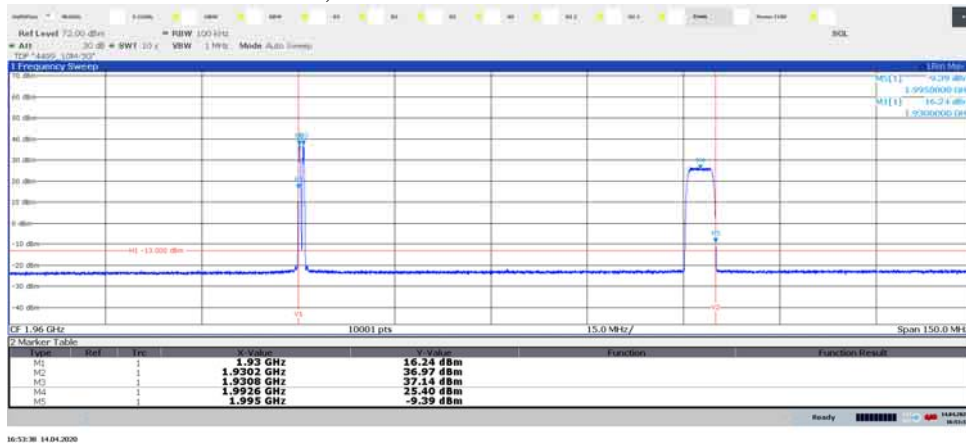


Diagram 3.19b, NB IoT SA: N-TM, WCDMA: TM1, Bim_{IoT+W}, 1.8875 GHz – 2.0375 GHz, Port A:



Note: The purpose of this measurement is to find IM products, not to verify compliance at the edges.

Diagram 3.19c, NB IoT SA: N-TM, WCDMA: TM1, Bim_{IoT+W}, 3 GHz – 22 GHz, Port A:

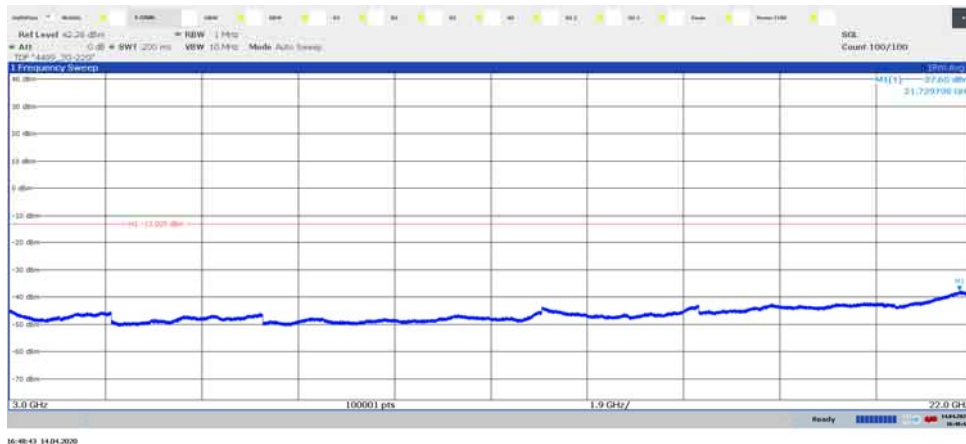


Diagram 3.20a, NB IoT SA: N-TM, WCDMA: TM1, $T_{im_{IoT+W}}$, 9 kHz – 3 GHz, Port A:

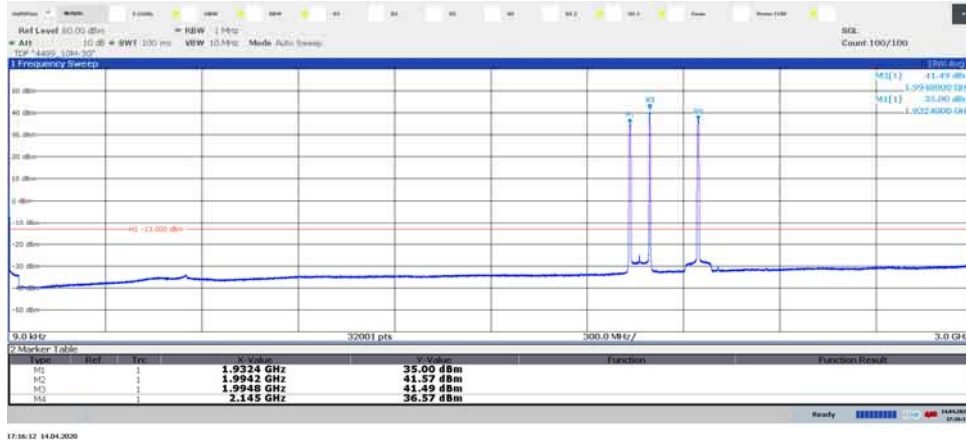
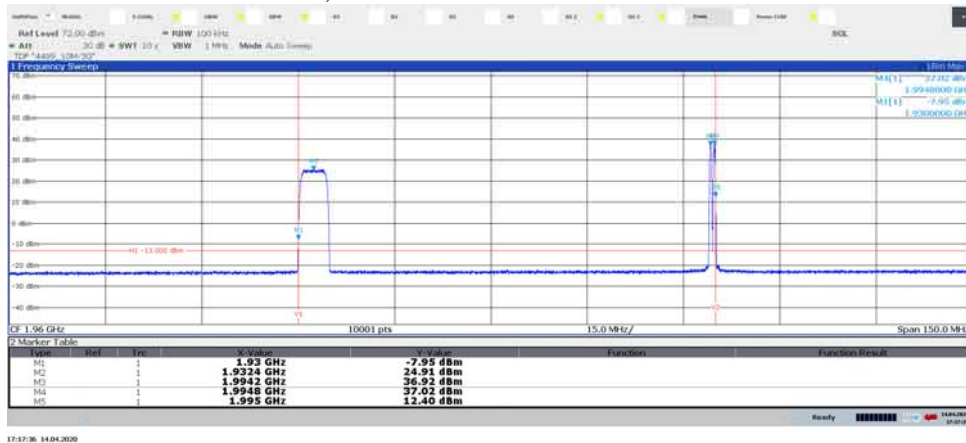


Diagram 3.20b, NB IoT SA: N-TM, WCDMA: TM1, $T_{im_{IoT+W}}$, 1.8875 GHz – 2.0375 GHz, Port A:



Note: The purpose of this measurement is to find IM products, not to verify compliance at the edges.

Diagram 3.20c, NB IoT SA: N-TM, WCDMA: TM1, $T_{im_{IoT+W}}$, 3 GHz – 22 GHz, Port A:

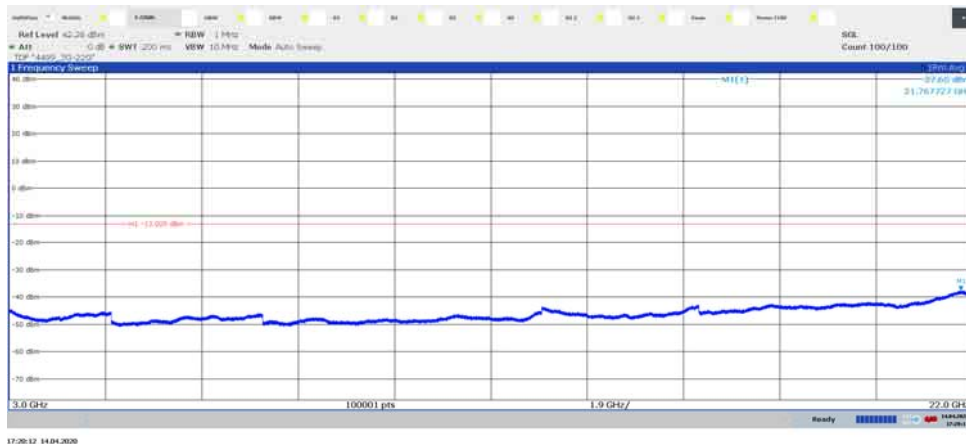


Diagram 3.21a, NB IoT SA: N-TM, WCDMA: TM1, Bim_{IoT+W}, 9 kHz – 3 GHz, Port B:

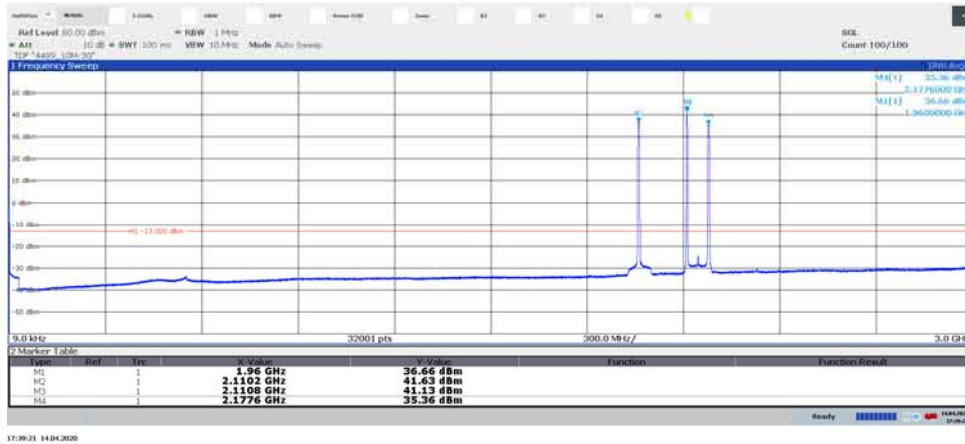
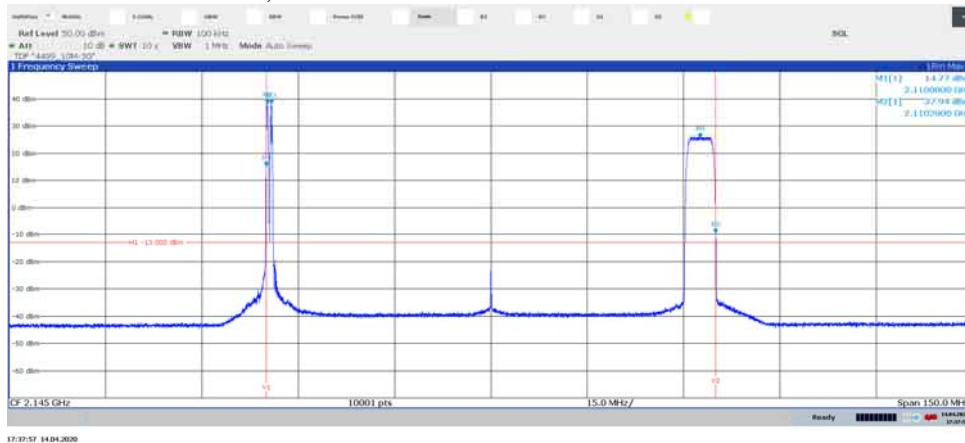


Diagram 3.21b, NB IoT SA: N-TM, WCDMA: TM1, Bim_{IoT+W}, 2.07 GHz – 2.22 GHz, Port B:



Note: The purpose of this measurement is to find IM products, not to verify compliance at the edges.

Diagram 3.21c, NB IoT SA: N-TM, WCDMA: TM1, Bim_{IoT+W}, 3 GHz – 22 GHz, Port B:

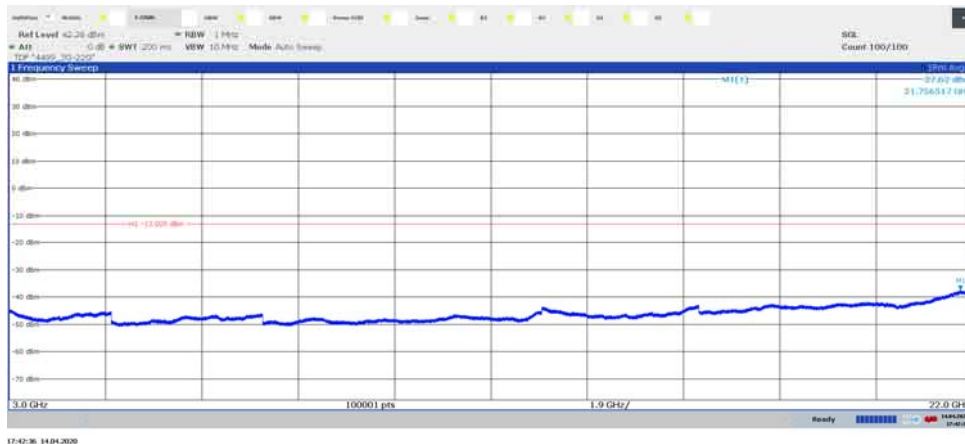


Diagram 3.22a, NB IoT SA: N-TM, WCDMA: TM1, $T_{im_{IoT+W}}$, 9 kHz – 3 GHz, Port B:

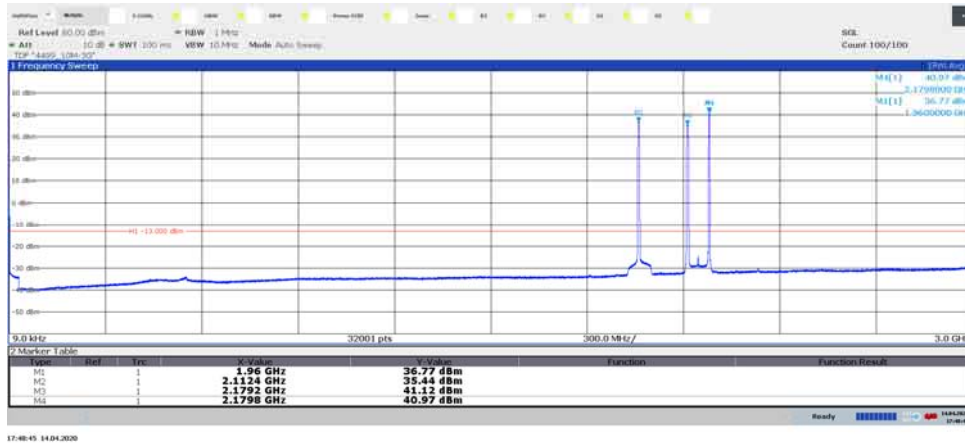
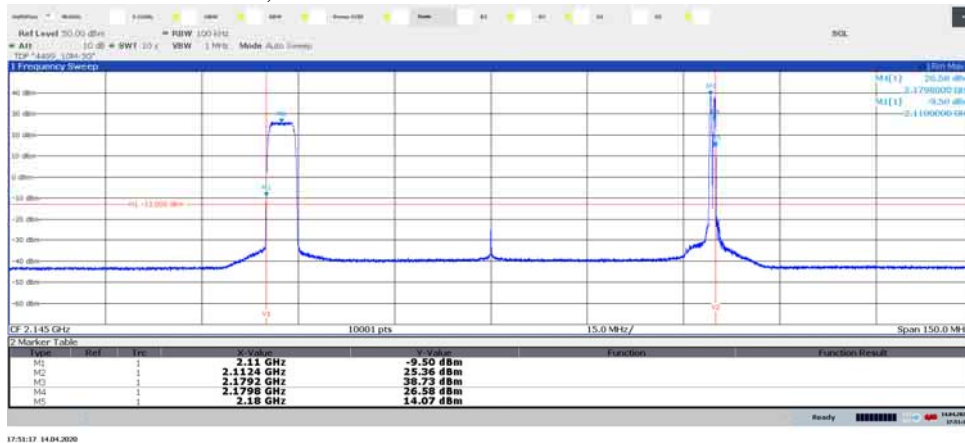


Diagram 3.22b, NB IoT SA: N-TM, WCDMA: TM1, $T_{im_{IoT+W}}$, 2.07 GHz – 2.22 GHz, Port B:



Note: The purpose of this measurement is to find IM products, not to verify compliance at the edges.

Diagram 3.22c, NB IoT SA: N-TM, WCDMA: TM1, $T_{im_{IoT+W}}$, 3 GHz – 22 GHz, Port B:

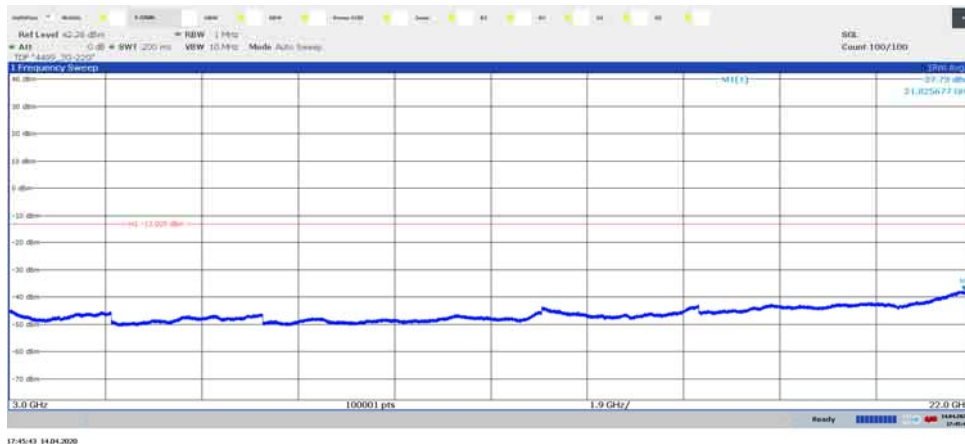


Diagram 3.23a, GSM: GMSK, NB IoT SA: N-TM, WCDMA: TM1, Bim_{G+IoT+W}, 9 kHz – 3 GHz, Port A:

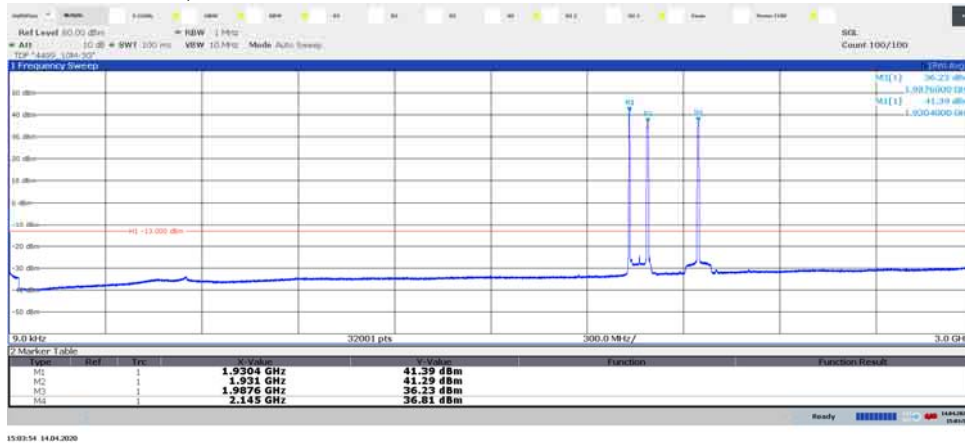


Diagram 3.23b, GSM: GMSK, NB IoT SA: N-TM, WCDMA: TM1, Bim_{G+IoT+W}, 1.8875 GHz – 2.0375 GHz, Port A:

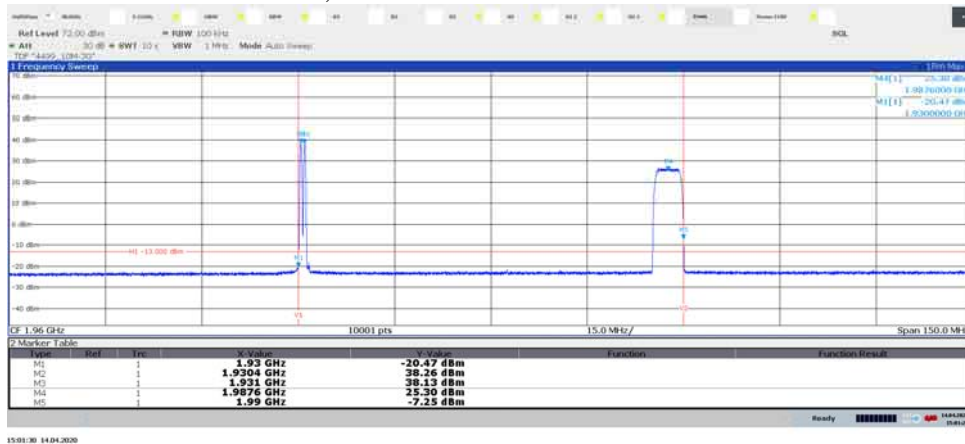


Diagram 3.23c, GSM: GMSK, NB IoT SA: N-TM, WCDMA: TM1, Bim_{G+IoT+W}, 3 GHz – 22 GHz, Port A:

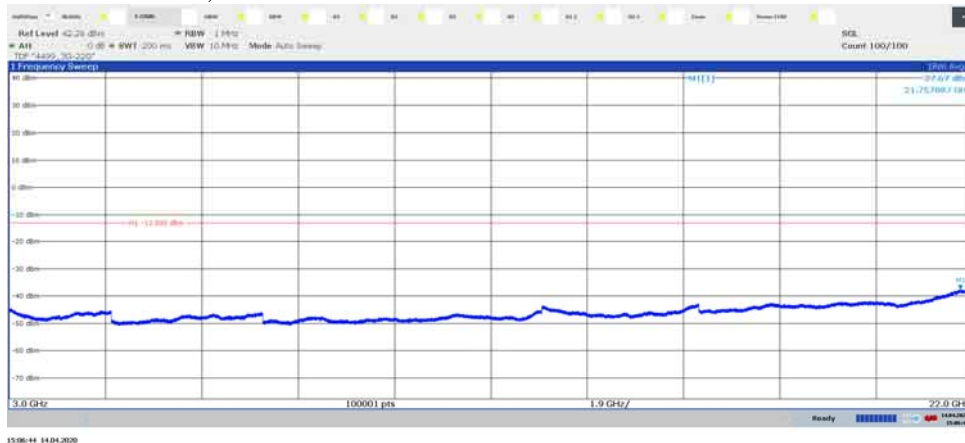


Diagram 3.24a, GSM: GMSK, NB IoT SA: N-TM, WCDMA: TM1, Tim_{G+IoT+W}, 9 kHz – 3 GHz, Port A:

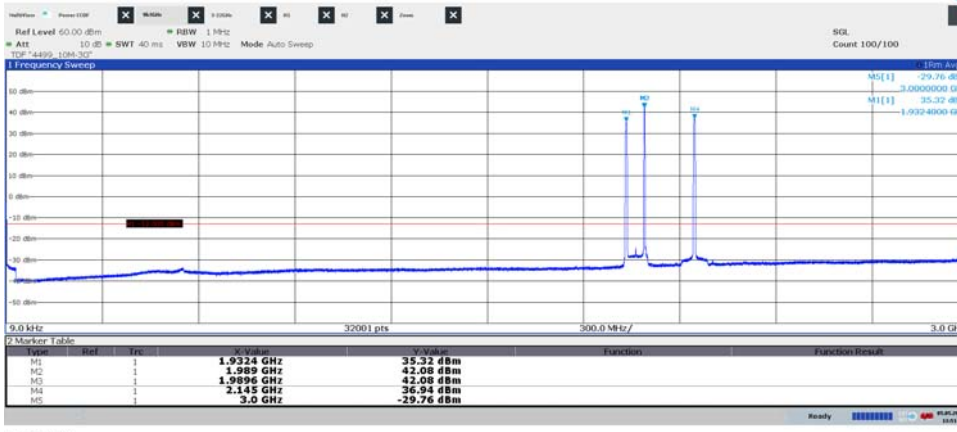


Diagram 3.24b, GSM: GMSK, NB IoT SA: N-TM, WCDMA: TM1, Tim_{G+IoT+W}, 1.8875 GHz – 2.0375 GHz, Port A:

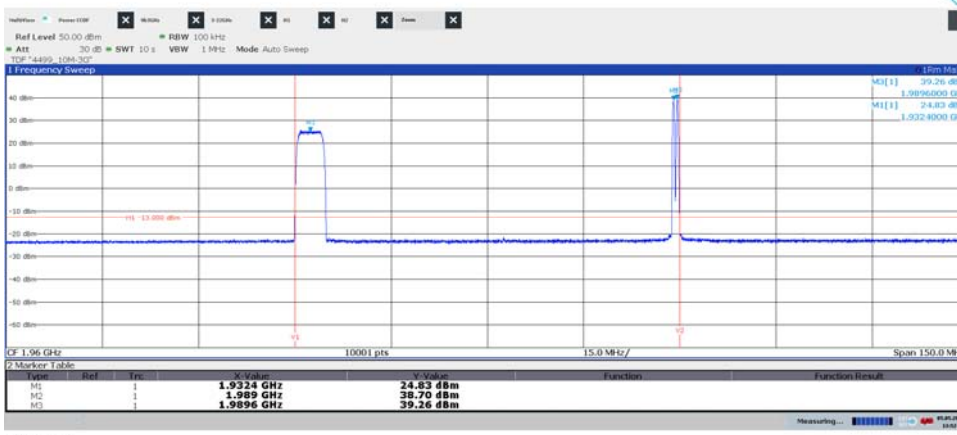


Diagram 3.24c, GSM: GMSK, NB IoT SA: N-TM, WCDMA: TM1, Tim_{G+IoT+W}, 3 GHz – 22 GHz, Port A:

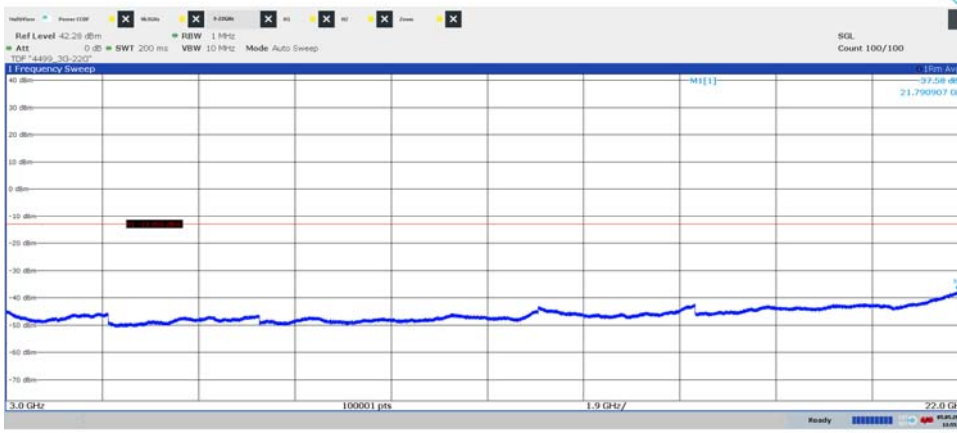


Diagram 3.25a, GSM: GMSK, NB IoT SA: N-TM, WCDMA: TM1, Max_{G+IoT+W}, 9 kHz – 3 GHz, Port A:

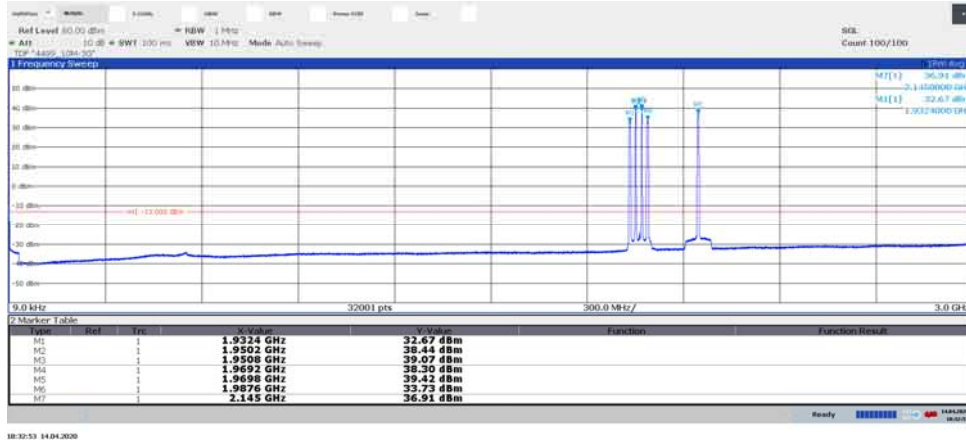
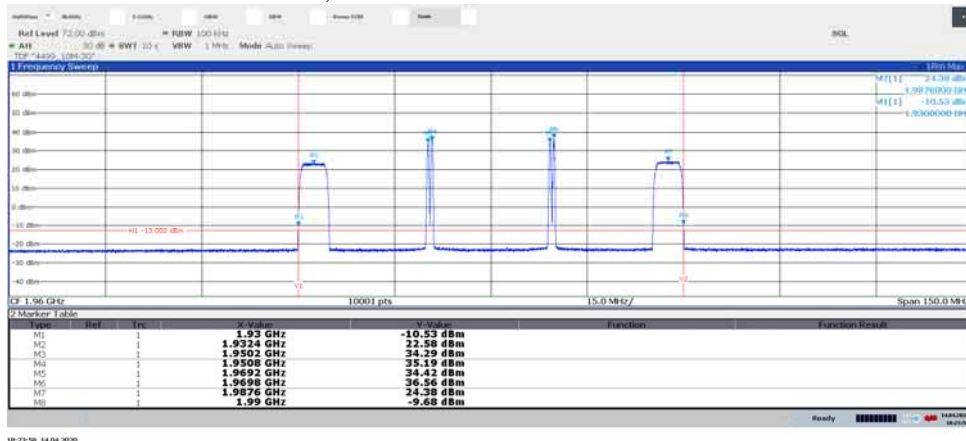
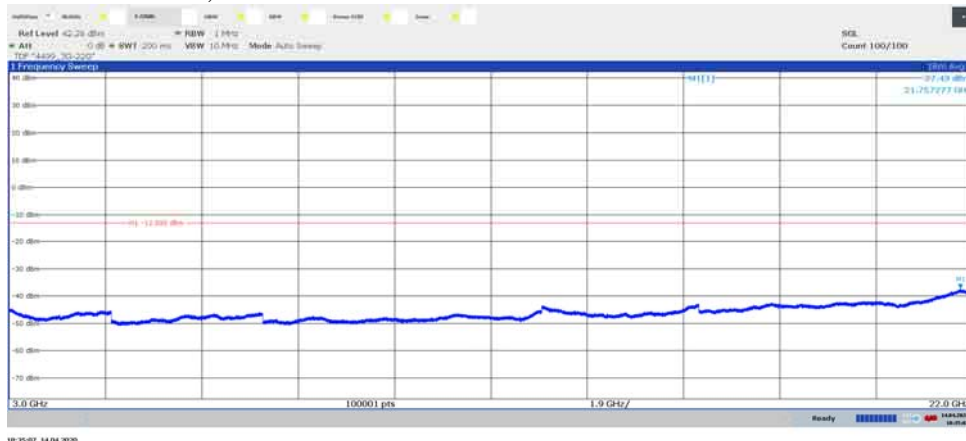


Diagram 3.25b, GSM: GMSK, NB IoT SA: N-TM, WCDMA: TM1, Max_{G+IoT+W}, 1.8875 GHz – 2.0375 GHz, Port A:



Note: The purpose of this measurement is to find IM products, not to verify compliance at the edges.

Diagram 3.25c, GSM: GMSK, NB IoT SA: N-TM, WCDMA: TM1, Max_{G+IoT+W}, 3 GHz – 22 GHz, Port A:



Field strength of spurious radiation measurements according to CFR 47 §24.238 and §27.53(h) / RSS-133 6.5, RSS-139 6.6

Date	Temperature	Humidity
2020-02-26	22 °C ± 3 °C	22 % ± 5 %
2020-02-27	22 °C ± 3 °C	20 % ± 5 %

The test site conforms to the site validation criterion specified in ANSI C63.4.

The measurements were performed with both horizontal and vertical polarization of the antenna. The antenna distance and test object height in the different frequency ranges can be seen below.

The antenna distance was 3 m in the frequency range 30 MHz – 18 GHz and 1 m in the frequency range 18 GHz – 26.5 GHz.

The EUT was placed 0.8 m above reference ground plane in frequency range 30 MHz – 1 GHz and 1.5 m above reference ground plane in frequency range 1 GHz – 26.5 GHz.

The measurement was performed with an RBW of 1 MHz.

A propagation loss in free space was calculated. The used formula was

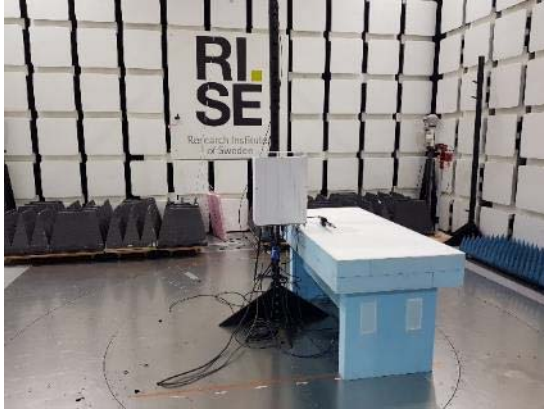
$$\gamma = 20 \log \left(\frac{4\pi D}{\lambda} \right), \gamma \text{ is the propagation loss and } D \text{ is the antenna distance.}$$

The measurement procedure was as the following:

1. A pre-measurement is performed with peak detector. For measurement < 1 GHz the test object was measured in eight directions with the antenna at three heights, 1.0 m, 1.5 m and 2.0 m. For measurements > 1 GHz the test object was measured in seventeen directions with the antenna height 1.5 m, 2.0 m and 2.5 m with elevation angle.
2. Spurious radiation on frequencies closer than 20 dB to the limit in the pre-measurement is scanned 0-360 degrees and the antenna is scanned 1- 4 m for maximum response. The emission is then measured with the RMS detector and the RMS value is reported. Frequencies closer than 10 dB to the limit when measured with the RMS detector were measured with the substitution method according to ANSI 63.26.

The test set-up during the spurious radiation measurements is shown in the pictures below:

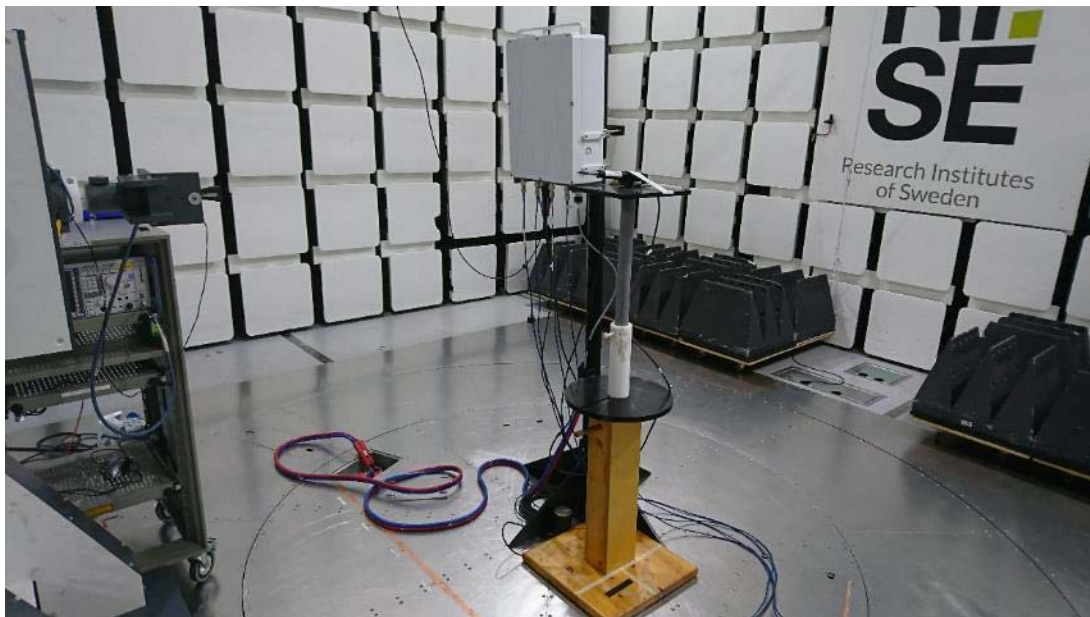
Test setup 30-1000 MHz:



Test setup 1-18 GHz:



Test setup 18-26.5 GHz:



Measurement equipment

Measurement equipment	RISE number
Test site Tesla	503 881
R&S ESU 40	901 385
Control computer with R&S software EMC32 version 10.60.10	BX62351
High pass filter 3-18 GHz	BX40074
Flann Standard Gain Horn 20240-20	BX92412
Teseq BiConiLog Antenna CBL6143A	BX92331
Coaxial cable, Tesla emission	BX91490
Coaxial cable	503 508
Coaxial cable	503 509
EMCO Horn Antenna 3115	502 175
µComp Nordic, Low Noise Amplifier	901 545
Miteq, Low Noise Amplifier	503 278
Temperature and humidity meter, Testo 625	504 188

Results

Tested configurations: B, M, T, T6, Bim and Tim representing worst case: Symbolic name T, TM5, Diagram 1 a-d

Frequency (MHz)	Spurious emission level (dBm)	
	Vertical	Horizontal
30-26500	All emission > 20 dB below limit	All emission > 20 dB below limit

Measurement uncertainty: 3.1 dB

Limits

CFR 47 §24.238 and §27.53(h)

Outside a licensee's frequency band(s) of operation the power of any emission shall be attenuated below the transmitter power (P) by at least 43 + 10 log (P) dB. resulting in a limit of -13 dBm.

Complies?	Yes
-----------	-----

Diagram 1a:

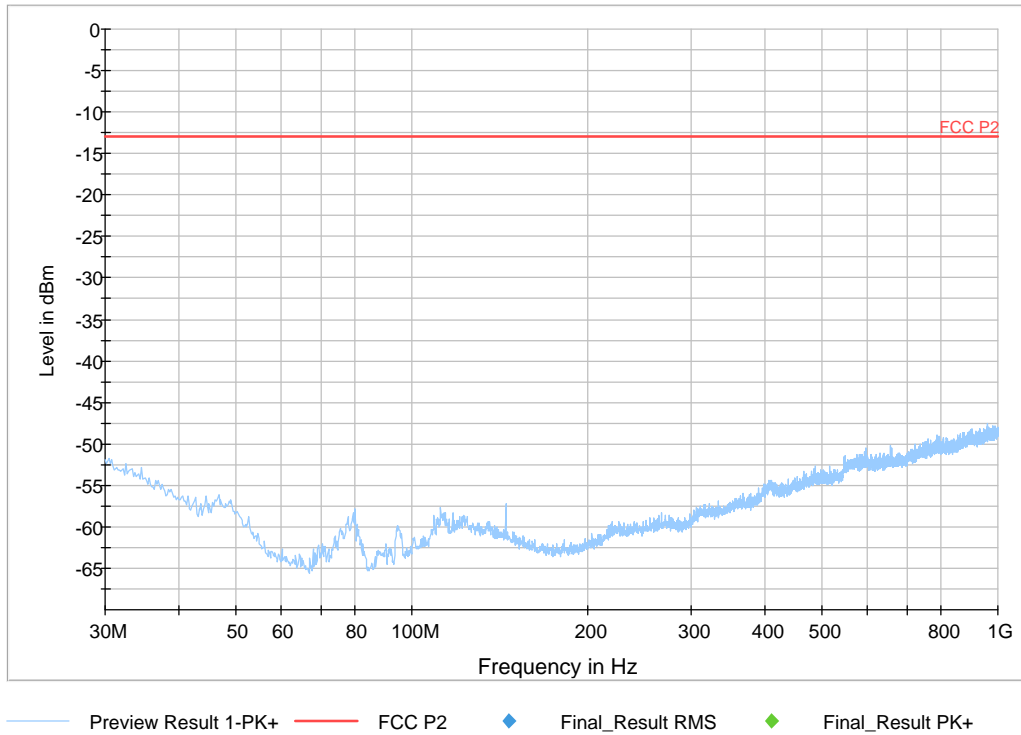
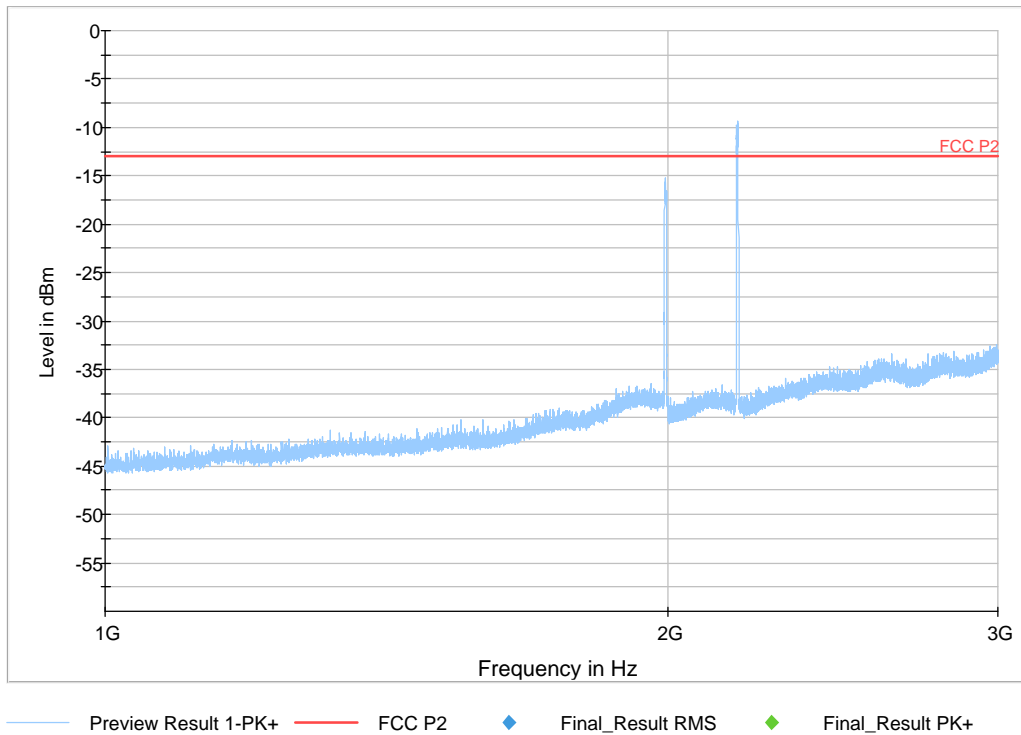


Diagram 1b:



Note: The emissions at 1992.6 MHz and 2177.6 MHz are the carrier frequency and shall be ignored in the context.

Diagram 1c:

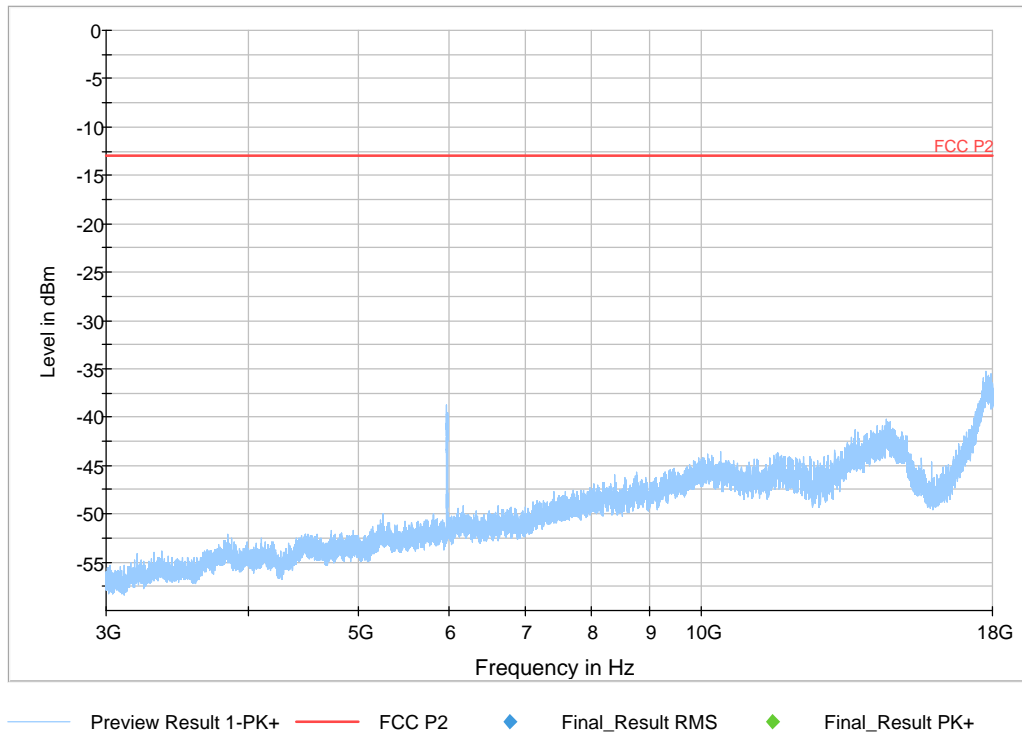
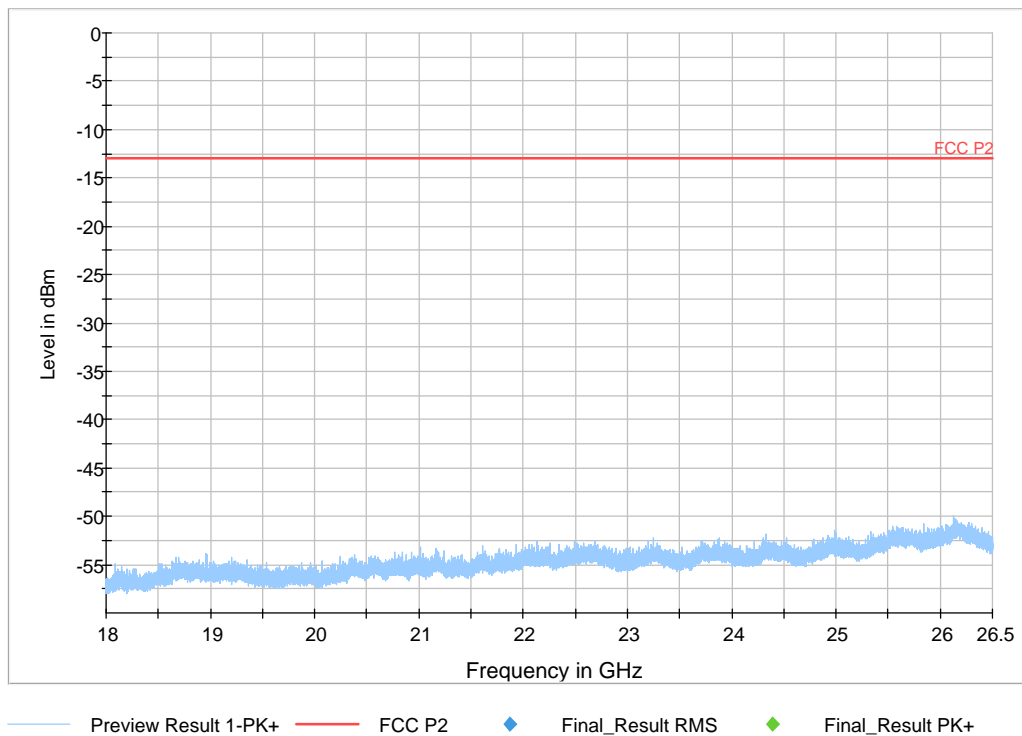


Diagram 1d:



Frequency stability measurements according to CFR 47 §24.235 and §27.54 / RSS-133 6.3 and IC RSS-139 6.4

Date	Temperature (test equipment)	Humidity (test equipment)
2020-03-16	23 °C ± 3 °C	15 % ± 5 %
2020-03-17	23 °C ± 3 °C	20 % ± 5 %
2020-03-18	23 °C ± 3 °C	18% ± 5 %
2020-03-19	23 °C ± 3 °C	20 % ± 5 %
2020-03-20	23 °C ± 3 °C	22 % ± 5 %

Test set-up and procedure

The measurement was made per 3GPP TS 25.141. The output was connected to a spectrum analyser. The spectrum analyser was connected to an external 10 MHz reference standard during the measurements.

Measurement equipment	RISE number
Rohde & Schwarz signal analyzer FSQ 40	504 143
Directional coupler	901 496
RF attenuator	902 282
Coaxial cable Megaphase	BX50191
Coaxial cable Sucoflex 102EA	BX50237
Temperature Chamber	503 360
Testo 635, temperature and humidity meter	504 203
Multimeter Fluke 87	502 190

Results WCDMA

Nominal transmitter frequency was for B25 1962.5 MHz (M) with a bandwidth of 5 MHz and rated output power level at connector RF A at 46 dBm.

Nominal transmitter frequency was for B66 2145 MHz (M) with a bandwidth of 5 MHz and rated output power level at connector RF A at 46 dBm.

Test conditions		Frequency error (Hz) B25	Frequency error (Hz) B66
Supply voltage DC (V)	Temp. (°C)		
40.8	+20	10	9
55.2	+20	9	9
48	+20	9	10
48	+30	7	7
48	+40	5	5
48	+50	4	5
48	+10	5	5
48	0	5	8
48	-10	8	7
48	-20	6	5
48	-30	7	7
Maximum freq. error (Hz)		10	10
Measurement uncertainty		$< \pm 1 \times 10^{-7}$	

B25

Rated output power level at connector RF A (maximum): 46.0 dBm

Test conditions			Frequency margin to band edge at -19 dBm			
Supply voltage DC [V]	Temp [°C].	Carrier Bandwidth [MHz]	Test frequency Symbolic name Bottom		Test frequency Symbolic name Top	
			fL [MHz]	Offset to lower band edge (1930 MHz) [kHz]	fH [MHz]	Offset to upper band edge (1995 MHz) [kHz]
-48.0	+20	5	1930.004	3.9	1994.996	3.9

B66

Rated output power level at connector RF A (maximum): 46 dBm

Test conditions			Frequency margin to band edge at -19 dBm			
Supply voltage DC [V]	Temp [°C].	Carrier Bandwidth [MHz]	Test frequency Symbolic name Bottom		Test frequency Symbolic name Top	
			fL [MHz]	Offset to lower band edge (2110 MHz) [kHz]	fH [MHz]	Offset to upper band edge (2180 MHz) [kHz]
-48.0	+20	5	2110.004	3.9	2179.995	5

The frequency error results clearly shows that the frequency stability is good enough to ensure that the transmitted carrier stay within the operating band.

Remark

It was deemed sufficient to test one combination of TX frequency, channel bandwidth configuration and test model (modulation), as all combinations share a common internal reference to derive the TX frequency from.

Limits

CFR 47 §24.235 and §27.54 / RSS-133 6.3 and RSS-139 6.4

The frequency stability shall be sufficient to ensure that the fundamental emission stays within the authorized frequency block.

Complies?	Yes
-----------	-----

Photos of test object

Front side



Rear side



Left side



Right side



Bottom side



Top side



Labels:

Radiated measurements:

Test object label:



SFP module Data 1:



SFP module Data 2:



Conducted measurements:

Test object label:



SFP module Data 1:



SFP module Data 2:



End of report.