

Contact person RISE

Tomas Lennhager
Safety and Transport
+46 10 516 54 09
tomas.lennhager@ri.se

Date

2020-10-27

Reference

2P06689-LW

Page

1 (41)

Ericsson AB
Anders Karlsson
BURA DURA RP QRM
Torshamnsgatan 21
164 80 Stockholm**Radio measurements on Radio 4480 44B2/B25 44B66A C
equipment with FCC ID TA8AKRC161844 and IC 287AB-
AS161844**

Product name: Radio 4480 44B2/B25 44B66A C

Product number: KRC 161 844/1 and KRC 161 844/3

**RISE Research Institutes of Sweden AB
Vehicles and Automation – EMC-IKT**

Performed by

Examined by

Tomas Lennhager

Daniel Lundgren

RISE Research Institutes of Sweden AB

Postal address

Box 857
SE-501 15 BORÅS
Sweden

Office location

Brinellgatan 4
SE-504 62 BORÅS

Phone / Fax / E-mail

+46 10 516 50 00
+46 33 13 55 02
info@ri.seThis report may not be reproduced other than in full, except
with the prior written approval of the issuing laboratory.

Summary 3

Description of the test object 4

Purpose of test 7

Origin of test data 7

Operation modes during measurements 7

Conducted measurements 7

Radiated measurements 8

Test facility 8

References 8

Measurement equipment 9

Uncertainties 9

Reservation 9

Delivery of test object 9

Manufacturer’s representative 9

Test engineers 10

Test participant(-s) 10

Test frequencies used for conducted measurements 11

Test frequencies used for radiated measurements 13

Test setup: conducted measurements 14

Test setup: radiated measurements 15

RF power output measurements according to CFR 47 §24.232 and §27.50/ RSS-133 6.4, RSS-139 5.5 conducted 16

 Test set-up and procedure 16

 Results 16

 Remark 17

 Limits 17

Conducted spurious emission measurements according to CFR 47 §24.238 and §27.53(h)/ RSS-133 6.5, RSS-139 6.6 18

 Test set-up and procedure 18

 Results WCDMA+LTE 19

 Results WCDMA+LTE+NB IoT SA 19

 Remark 20

 Limits 20

Field strength of spurious radiation measurements according to CFR 47 §24.238 and §27.53(h) / RSS-133 6.5, RSS-139 6.6 33

 Measurement equipment 35

 Results 35

 Limits 35

Photos of test object 38

Summary

Standard Listed part of	Compliant
FCC CFR 47 part 24 and part 27/ RSS-133, RSS-139, RSS-Gen	
2.1046/ 6.4/ 6.5 RF power output	Yes
2.1051/ 6.5/ 6.6 Spurious emission at antenna terminals	Yes
2.1053/ 6.5/ 6.6 Field strength of spurious radiation	Yes

Description of the test object

Equipment:	<p>Radio 4480 44B2/B25 44B66A C Product number KRC 161 844/1 and KRC 161 844/3* FCC ID: TA8AKRC161844 IC: 287AB-AS161844</p> <p>*KRC 161 844/3 is the NEBS version of the same product</p>
HVIN:	AS161844
FVIN:	CXP 901 3268/15, rev. R81JH09
Hardware revision state:	R1A
Radio Access Technology, RAT and Frequency range:	<p>Band 2 (B2): Single RAT: W, L, NB IoT SA, NR Multi RAT: G+W+NB IoT SA, G+L+NB IoT SA, W+L+NB IoT SA, NR+L+NB IoT SA, G+L+NR, W+L+NR</p> <p>TX: 1930 – 1990 MHz RX: 1850 – 1910 MHz</p> <p>Band 25 (B25): Single RAT: W, L, NB IoT SA, NR Multi RAT: W+L+NB IoT SA, NR+L+NB IoT SA, W+L+NR</p> <p>TX: 1930 – 1995 MHz RX: 1850 – 1915 MHz</p> <p>Band 66 (B66): Single RAT: W, L, NB IoT SA, NR Multi RAT: W+L+NB IoT SA, NR+L+NB IoT SA, W+L+NR</p> <p>TX: 2110 – 2180 MHz RX: 1710 – 1780 MHz</p> <p>For WCDMA in B66 the frequencies are as follows: TX: 2110 – 2155 MHz RX: 1710 – 1755 MHz</p>
IBW:	<p>B2: 60 MHz B25: 65 MHz B66: 70 MHz</p>
Output power:	<p>Maximum output power per carrier:</p> <p>NR: 5 MHz: 40 W 10, 15, 20 MHz: 60 W</p> <p>LTE: 1.4 and 3 MHz: 20 W (1.4 MHz and 3 MHz carriers are not supported in B66) 5 MHz: 40 W</p>

10, 15, 20 MHz: 60 W

WCDMA: 40 W

GSM: 20 W (only available in B2)

NB IoT SA: 20 W

Maximum total output power/port: 80 W without optional fan

Maximum total output power/port: 100 W with optional fan

Maximum total output power/band and port: 60 W

Antenna ports B2/B25: A-D: 4 TX / 4 RX ports

Antenna ports B66: A-D: 4 TX / 4 RX ports

Antenna: No dedicated antenna, handled during licensing.

RF configuration: Single and multi-carrier, 1-12 carriers per port for both bands(6 in each band), Non-Contiguous Spectrum (NCS), Contiguous Spectrum (CS).

NR: Max 6 carriers per Band and port, TX Diversity, 2x2 MIMO, 4x4 MIMO, Carrier Aggregation (CA) intra-band and inter-band supported.

LTE: Max 6 carriers per Band and port, TX Diversity, 2x2 MIMO, 4x4 MIMO, Carrier Aggregation (CA) intra-band and inter-band supported.

WCDMA: Max 6 carriers per band and port, 2x2 MIMO, 4x4 MIMO.

GSM: Max 4 carriers per port, Single antenna, dual TX and Quad RX.

NB IoT SA: Max 2 carriers per band and port.

NB IoT Guard Band (GB): Max 1 Anchor PRB + 1 Non-Anchor PRB (For 10 MHz LTE carriers and wider).

NB IoT Inband (IB): Max 1 Anchor PRB + 1 Non-Anchor PRB (For 3 MHz LTE carriers and wider).

Channel bandwidths: NR: 5 MHz, 10 MHz 15 MHz and 20 MHz

LTE: 1.4 MHz, 3MHz, 5 MHz, 10 MHz 15 MHz and 20 MHz

WCDMA: 5 MHz

GSM: 200 kHz

NB IoT: 200 kHz

Sub-carrier spacing:	LTE and NR: 15 kHz		
Modulations:	NR: QPSK, 16QAM, 64QAM and 256QAM		
	LTE: QPSK, 16QAM, 64QAM and 256QAM		
	WCDMA: QPSK, 16QAM and 64QAM		
	GSM: GMSK, AQPSK and 8-PSK		
	NB IoT SA/ GB/ IB: QPSK, BPSK (BPSK is for up link only)		
Emission designators:	NR:	5 MHz: 4M50W7D 10 MHz: 9M29W7D 15 MHz: 14M2W7D 20 MHz: 18M9W7D 35 MHz: 33M9W7D (15+20 MHz, Carrier aggregation, only B66)	
	LTE with and without NB IoT IB:	1.4 MHz BW: 1M10W7D 3 MHz BW: 2M69W7D 5 MHz BW: 4M48W7D 10 MHz BW: 8M97W7D 15 MHz BW: 13M5W7D 20 MHz BW: 17M9W7D 40 MHz BW: 37M8W7D (2x20 MHz, Carrier Aggregation)	
	WCDMA:	4M20F9W	
	GSM:	GMSK: 245KGXW AQPSK: 241KGXW 8PSK: 245KG7W	
	NB IoT SA:	200KW7D	
	LTE with NB IoT GB:	10 MHz BW: 9M39W7D 15 MHz BW: 14M0W7D 20 MHz BW: 18M4W7D	
	RF power Tolerance:	+0.6/ -2.5 dB	
	CPRI Speed	Up to 10.1 Gbit/s	
	Nominal supply voltage:	-48VDC	

The information above is supplied by the manufacturer.

Tested configurations in this report: Multi RAT: WCDMA+ LTE+ NB IoT SA

Purpose of test

The purpose of the tests is to verify compliance to the performance characteristics specified in applicable items of FCC CFR 47 part 24 and Part 27, ISSED RSS-133, RSS-139 and RSS-Gen.

Origin of test data

The test data in this report is from measurements performed on a similar version of this radio. Justification of the test data reuse is addressed in the operational description document included in the filing.

Operation modes during measurements

WCDMA measurements were performed with the test object transmitting the Test model 1 which are defined in 3GPP TS 25.141. Test model 1 (TM1) represent QPSK modulation. Test model 5 (TM5) includes the 16QAM modulation and Test model 6 (TM6) includes the 64QAM modulation.

LTE measurements were performed with the test object transmitting test models as defined in 3GPP TS 36.141. Test model E-TM1.1 was used to represent QPSK, test model E-TM3.2 to represent 16QAM, test model E-TM3.1 to represent 64QAM modulation and E-TM3.1A to represent 256QAM modulation. E-TM1.1 represents worst case.

NB IoT SA (Stand Alone)

NB IoT SA measurements were performed with the test object transmitting test model N-TM representing QPSK as defined in 3GPP TS 36.141.

B2 and B25 overlap each other. They both have the same lower edge but the upper edge for B25 is 5 MHz higher. For measurements on middle configuration, the middle frequency for B25 was deemed representative for both bands. For band edge measurements on the top frequency configuration the measurements were repeated for the upper edge of both B2 and B25.

For all measurements the radio was configured with the total output power of 80 watts per port. For measurements noted with B25 max power configuration the Carrier(s) were configured with the maximum possible output power for the Carrier(s) in that band. The carrier in Band 66 was a 10 MHz LTE carrier on 2145 MHz configured with the necessary output power to reach the maximum power per port of 80 watts.

For measurements noted with B66 max power configuration, the Carrier(s) were configured with the maximum possible output power for the Carrier(s) in that band. The carrier in Band 2/25 was a 10 MHz LTE carrier on 1962.5 MHz configured with the necessary output power to reach the maximum power per port of 80 watts.

Conducted measurements

The test object was supplied with -48 VDC by an external power supply. Additional connections are documented in the set-up drawings for conducted measurements.

The signal path of the measurement chain was calibrated with a network analyzer and the correction stored as a transducer factor in the measurement equipment.

Radiated measurements

The test object was powered with -48 VDC by an external power supply. Additional connections are documented in the set-up drawings for radiated measurements.

$$\text{EUT Emission} = \text{SA reading} + (\text{CableLosses} - \text{Antenna gain(dBi)} + \text{TheoreticalPathloss} + \text{FilterLoss} - \text{LNAGAIN})$$

The correction factors are stored in R&S EMC 32 software as separate files and activated as applicable in the Hardware setup, for each measurement configuration. Emissions close or above the limit is verified with the substitution method where the EUT is replaced by a signal generator and an Antenna with known gain.

Test facility

The used semi-anechoic chamber is compliant with ANSI C63.4. RISE is an ISO 17025 accredited test facility for Electromagnetic Compatibility (EMC) and Radio testing. RISE is a Recognized Lab under FCC and ISED (registration No. 3482A) rules for the scope of standards used in this test report..

References

Measurements were done according to relevant parts of the following standards:

- ANSI C63.4-2014+ C63.4a-2017
- ANSI C63.5-2017
- ANSI C63.26-2015
- CFR 47 part 2, March 2020
- CFR 47 part 24, March 2020
- CFR 47 part 27, March 2020
- KDB 484596 D01 Referencing Test Data v01
- KDB 971168 D03 IM Emission Repeater Amp v01
- 3GPP TS 25.141, version 15.3.0
- 3GPP TS 36.141, version 15.3.0
- RSS-Gen Issue 5 Amendment 1
- RSS-133 Issue 6 Amendment 1
- RSS-139 Issue 3

Measurement equipment

	Calibration Due	RISE number
Test site Tesla	2022-12	503 881
Test site Marconi	-	15:121
R&S ESU 40	2021-01	901 385
R&S FSQ 40	2021-07	504 143
R&S FSW 43	2021-07	902 073
Control computer with R&S software EMC32 version 10.20.01	-	BX62351
Directional coupler	2021-02	901 496
RF attenuator	2021-02	902 282
High pass filter 3-27 GHz	2021-02	901 502
High pass filter 3-27 GHz	2021-02	BX40074
Coaxial cable Megaphase	2021-02	BX50191
Coaxial cable Sucoflex 102EA	2021-02	BX50236
Coaxial cable Sucoflex 102EA	2021-02	BX50237
Coaxial cable, Tesla emission	2021-06	BX91490
Coaxial cable	2021-09	503 508
Coaxial cable	2021-09	503 509
Teseq BiConiLog Antenna CBL6143A	2022-09	BX92331
EMCO Horn Antenna 3115	2021-07	502 175
Flann Standard Gain Horn 20240-20	-	BX92412
Miteq, Low Noise Amplifier	2021-01	503 278
µComp Nordic, Low Noise Amplifier	2021-01	901 545
Temperature and humidity meter, Testo 635	2021-06	504 203
Temperature and humidity meter, Testo 625	2021-06	504 188

Uncertainties

Measurement and test instrument uncertainties are described in the quality assurance documentation "SP-QD 10885". The uncertainties are calculated with a coverage factor $k=2$ (95% level of confidence).

Compliance evaluation is based on a shared risk principle with respect to the measurement uncertainty.

Reservation

The test results in this report apply only to the particular test object as declared in the report.

Delivery of test object

The test object was delivered: 2020-02-10.

Manufacturer's representative

Mikael Jansson, Ericsson AB.

Test engineers

Tomas Isbring and Andreas Björnqvist for radiated tests, RISE
Tomas Lennhager and Karl Flysjö for conducted tests, RISE.

Test participant(-s)

None.

Test frequencies used for conducted measurements

Band 25 WCDMA+LTE:

Frequency [MHz]	Symbolic name	Comment
W ₁ =1950.0 L ₁ =1955.0 W ₂ =1960.0 L ₂ =1965.0 W ₃ =1970.0 L ₃ =1975.0	BMT6	TX max carrier constellation with 5 MHz LTE carriers, 40 dBm output power per carrier (47.8 dBm total output power).
W ₁ =1932.4 W ₂ =1937.4 L=1992.5	Bim _{W+L}	3-carriers TX constellation for Bim with 5 MHz LTE carriers, 43 dBm output power per carrier (47.8 dBm total output power).
W=1932.4 L ₁ =1987.5 L ₂ =1992.5	Tim _{W+L}	3-carriers TX constellation for Tim with 5 MHz LTE carriers, 43 dBm output power per carrier (47.8 dBm total output power).

Band 25 WCDMA+NB IoT SA+LTE:

Frequency [MHz]	Symbolic name	Comment
W ₁ =1932.4 IoT=1936.0 L=1992.5	Bim _{W+IoT+L}	3-carriers TX constellation for Bim with 5 MHz LTE carriers, 43 dBm output power per carrier (47.8 dBm total output power).
W=1932.4 IoT=1989.0 L=1992.5	Tim _{W+IoT+L}	3-carriers TX constellation for Tim with 5 MHz LTE carriers, 43 dBm output power per carrier (47.8 dBm total output power).

The RX frequency was configured 80 MHz below the corresponding TX frequency according to the applicable duplex offset for the operating band.

Band 66 WCDMA+LTE:

Frequency [MHz]	Symbolic name	Comment
W ₁ =2112.4 L ₁ =2117.5 W ₂ =2142.4 W ₂ =2152.6 L ₃ =2172.5 L ₃ =2177.5	BMT6	TX max carrier constellation with 5 MHz LTE carriers, 40 dBm output power per carrier (47.8 dBm total output power).
W ₁ =2112.4 W ₂ =2117.4 L=2177.5	Bim _{W+L}	3-carriers TX constellation for Bim with 5 MHz LTE carriers, 43 dBm output power per carrier (47.8 dBm total output power).
W=2112.4 L ₁ =2172.5 L ₂ =2177.5	Tim _{W+L}	3-carriers TX constellation for Tim with 5 MHz LTE carriers, 43 dBm output power per carrier (47.8 dBm total output power).

Band 66 WCDMA+NB IoT SA+LTE:

Frequency [MHz]	Symbolic name	Comment
W ₁ =2112.4 IoT=2116.0 L=2177.5	Bim _{W+IoT+L}	3-carriers TX constellation for Bim with 5 MHz LTE carriers, 43 dBm output power per carrier (47.8 dBm total output power).
W=2112.4 IoT=2174.0 L=2177.5	Tim _{W+IoT+L}	3-carriers TX constellation for Tim with 5 MHz LTE carriers, 43 dBm output power per carrier (47.8 dBm total output power).

All RX frequencies were configured 400MHz below the corresponding TX frequency according the applicable duplex offset for the operating band.

Test frequencies used for radiated measurements

Band 25 and Band 66

Frequency [MHz]	Symbolic name	Comment
L ₁ =1987.5 W ₁ =1992.6 W ₂ =2152.6 L ₂ =2177.5	T _{W+L}	4 carriers TX constellation, 43 dBm output power per carrier (47.8 dBm total output power).

For Band 2/25 the RX frequency was configured 80 MHz below the corresponding TX frequency according to the applicable duplex offset for the operating band.

For Band 66 the RX frequencies were configured 400 MHz below the corresponding TX frequency according to the applicable duplex offset for the operating band.

Test setup: conducted measurements

Setup for measurements from 9 kHz to 3 GHz.

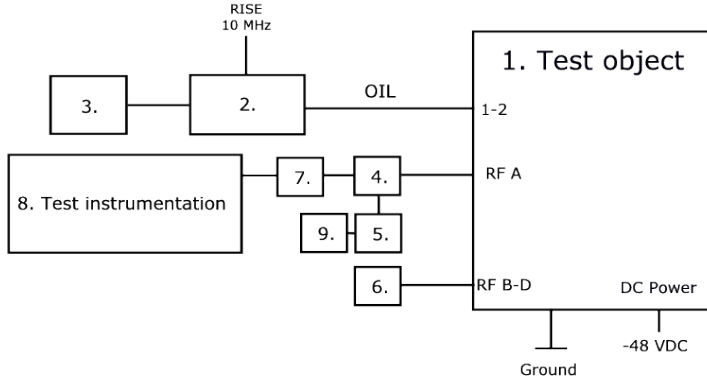

Setup for measurements from 3 GHz to 22GHz.

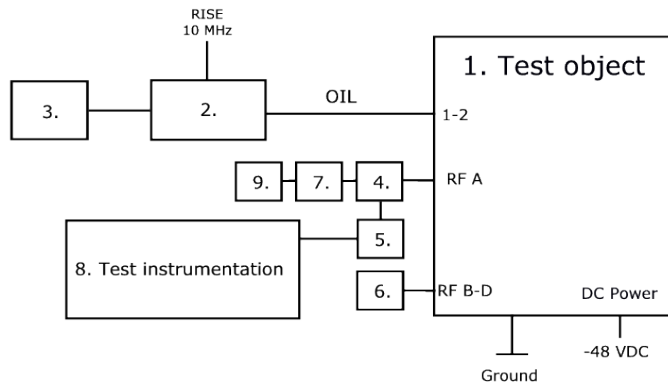

Test object:

1.	Radio 4499 44B2/B25 44B66A C, KRC 161 847/1, rev. R1A, s/n: E23B067325 With Radio Software: CXP 901 3268/15, rev. R81JH09 FCC ID: TA8AKRC161847, IC: 287AB-AS161847
----	---

Associated equipment:

2.	Testing Equipment: CT10, LPC 102 487/1, rev. R1C, s/n: T01F265039, BAMS – 1001908401 with software CXC 173 5312/29, rev. R1A02
----	--

Functional test equipment:

3.	Computer, HP ZBook 15u G3, BAMS - 1001835579
4.	Directional Coupler: RISE-number: 901 496
5.	High pass filter 3-27 GHz: RISE-Number: 901 502
6.	50 ohm terminator on each port
7.	RF Attenuator: RISE number: 902 282
8.	RISE Test Instrumentation according to measurement equipment list for each test. The signal analyzer was connected to the RISE 10 MHz reference standard during all measurements.
9.	50 ohm SMA terminator.

Test setup: radiated measurements

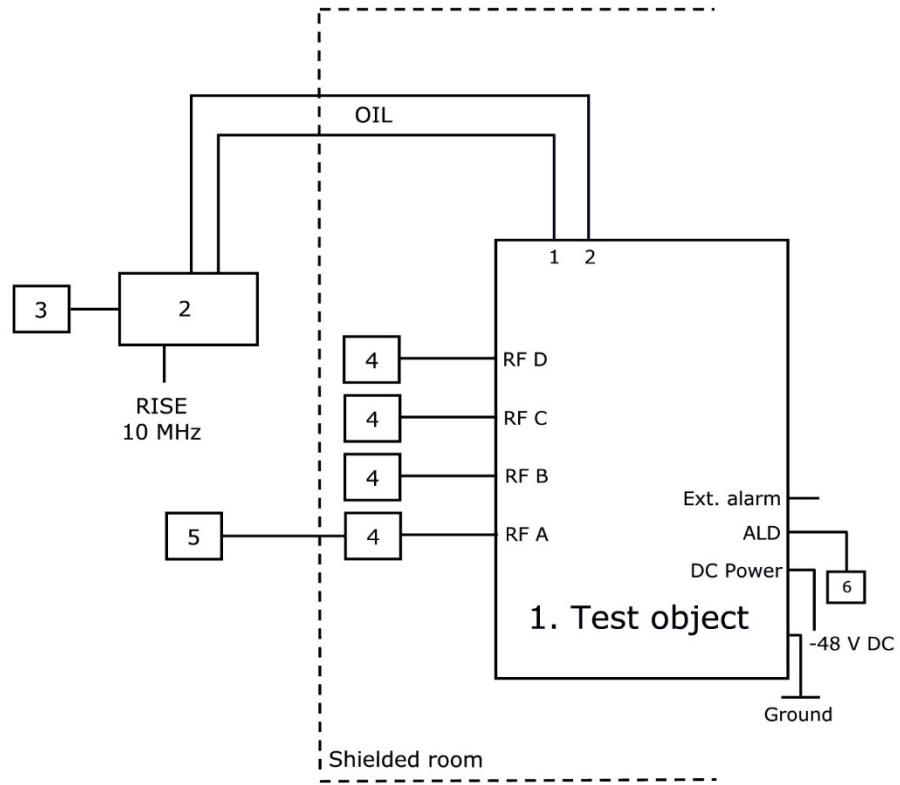

1.	Radio 4499 44B2/B25 B66A C, KRC 161 847/1, rev. R1A, s/n: E23B067329 With Radio Software: CXP 901 3268/15, rev. R81JH09. FCC ID: TA8AKRC161847, IC: 287AB-AS161847
----	--

Associated equipment:

2.	Testing Equipment: CT10, LPC 102 487/1, rev. R1C, s/n: T01F265031, BAMS – 1000797753 with software CXC 173 5312/25, rev. R1A07
----	--

Functional test equipment:

3.	HP EliteBook 8560w, BAMS – 1001236854
4.	Attenuator/ Terminator
5.	R&S ESIB 26, SP no: 503 292 for supervision purpose only
6.	Remote Control Unit, ANDREW Model: ATM200-A20, Serial: CN10151085133

Interfaces:

Power input configuration DC: -48 VDC	Power
RF A-D, 4.3-10 connector, combined TX/RX	Antenna
1, Optical Interface Link, single mode opto fibre	Signal
2, Optical Interface Link, single mode opto fibre	Signal
ALD Control, shielded multi-wire	Signal
EXT Alarm, shielded multi-wire	Signal
Ground wire	Ground

RF power output measurements according to CFR 47 §24.232 and §27.50/ RSS-133 6.4, RSS-139 5.5 conducted

Date	Temperature	Humidity
2020-04-15	22 °C ± 3 °C	25 % ± 5 %
2020-04-16	22 °C ± 3 °C	12 % ± 5 %
2020-09-30	24 °C ± 3 °C	35 % ± 5 %

Test set-up and procedure

The measurements were made per definition in ANSI C63.26, 5.2.3.4. The test object was connected to a signal analyser measuring peak and RMS output power in CDF mode. A resolution bandwidth of 80 MHz was used if not otherwise.

Measurement equipment	RISE number
R&S FSW 43	902 073
R&S FSQ 40	504 143
Directional coupler	901 496
RF attenuator	902 282
Coaxial cable Megaphase	BX50191
Coaxial cable Sucoflex 102EA	BX50237
Testo 635, temperature and humidity meter	504 203

Measurement uncertainty: 1.1 dB

Results

Band 25 max power configuration:

WCDMA: TM1, LTE: E-TM1.1

Rated output power level at each RF port 6x 40 dBm (47.8 dBm total power)/ port.

Symbolic name	Output power CCDF [RMS dBm]				
	Port RF A	Port RF B	Port RF C	Port RF D	Total power ¹⁾
BMT6	46.32	46.49	46.37	46.50	52.44

¹⁾: summed output power according to ANSI C63.26 section 6.4.3.1

Band 66 max power configuration:

WCDMA: TM1, LTE: E-TM1.1

Rated output power level at each RF port 6x 40 dBm (47.8 dBm total power)/ port.

Symbolic name	Output power CCDF [RMS dBm]				
	Port RF A	Port RF B	Port RF C	Port RF D	Total power ¹⁾
BMT6	46.82	46.93	46.76	46.80	52.85

¹⁾: summed output power according to ANSI C63.26 section 6.4.3.1

Remark

ERP/EIRP compliance is addressed at the time of licensing, as required by the responsible FCC/ISED Bureau(s). Licensee's are required to take into account maximum antenna gain used in combination with above power settings to prevent the radiated output power to exceed the limits.

Limits

§24.232 and RSS-133 6.4/SRSP-510 5.1.1

The maximum output power may not exceed 3280 W/MHz (EIRP).

In measuring transmissions in this band using an average power technique, the peak-to-average ratio (PAR) of the transmission may not exceed 13 dB.

§27.50 (d) an RSS-139 6.5/SRSP-513 5.1.1

The maximum output power may not exceed 3280 W/MHz (EIRP).

In measuring transmissions in this band using an average power technique, the peak-to-average ratio (PAR) of the transmission may not exceed 13 dB.

Complies?	Yes
-----------	-----

Conducted spurious emission measurements according to CFR 47 §24.238 and §27.53(h)/ RSS-133 6.5, RSS-139 6.6

Date	Temperature	Humidity
2020-04-15	22 °C ± 3 °C	25 % ± 5 %
2020-04-16	22 °C ± 3 °C	12 % ± 5 %
2020-04-22	22 °C ± 3 °C	13 % ± 5 %
2020-09-30	24 °C ± 3 °C	35 % ± 5 %

Test set-up and procedure

The measurements were made per definition in ANSI C63.26, 5.7.4. The output was connected to a spectrum analyzer with the RMS detector activated.

Before comparing the results to the limit, 6 dB [10 log₁₀ (4)] to cover 4x4 MIMO, should be added according to ANSI C63.26 6.4.4.1 c “measure and add 10 log₁₀ (N_{ANT})”.

Measurement equipment	RISE number
R&S FSW 43	902 073
R&S FSQ 40	504 143
Directional coupler	901 496
RF attenuator	902 282
High pass filter 3-27 GHz	901 502
Coaxial cable Megaphase	BX50191
Coaxial cable Sucoflex 102EA	BX50236
Coaxial cable Sucoflex 102EA	BX50237
Testo 635, temperature and humidity meter	504 203

Measurement uncertainty: 3.7 dB

Results WCDMA+LTE

Band 25 max power configuration:

Multi RAT: WCDMA: TM1, LTE: E-TM1.1

Diagram	Symbolic name	Tested Port
3.1 a-b	Bim _{W+L}	RF A
3.2 a-b	Tim _{W+L}	RF A
3.3 a-b	BMT6	RF A

Note: Measurements were mainly limited to port RF A due to the measurement result in single carrier mode that shows that the ports are electrical identical as declared by the client.

Band 66 max power configuration:

Multi RAT: WCDMA: TM1, LTE: E-TM1.1

Diagram	Symbolic name	Tested Port
3.4 a-c	Bim _{W+L}	RF B
3.5 a-c	Tim _{W+L}	RF B
3.6 a-e	BMT6	RF B

Note: Measurements were mainly limited to port RF B due to the measurement result in single carrier mode that shows that the ports are electrical identical as declared by the client.

Results WCDMA+LTE+NB IoT SA

Band 25 max power configuration:

Multi RAT: WCDMA: TM1, LTE: E-TM1.1, NB IoT SA: N-TM

Diagram	Symbolic name	Tested Port
3.7 a-c	Bim _{W+L+IoT}	RF A
3.8 a-c	Tim _{W+L+IoT}	RF A

Band 66 max power configuration:

Multi RAT: WCDMA: TM1, LTE: E-TM1.1, NB IoT SA: N-TM

Diagram	Symbolic name	Tested Port
3.9 a-c	Bim _{W+L+IoT}	RF A
3.10 a-c	Tim _{W+L+IoT}	RF A

Remark

The emission at 9 kHz on the plots was not generated by the test object. A complementary measurement with a smaller RBW showed that it was related to the LO feed-through.

The highest fundamental frequency is 2180 MHz. The measurements were made up to 22 GHz (10x2180 MHz = 21.80 GHz).

Limits

CFR 47 §24.238, §27.53(h) and RSS-133 6.5, RSS-139 6.6

- i. In the 1.0 MHz bands immediately outside and adjacent to the equipment's operating frequency block, the emission power per any 1% of the emission bandwidth shall be attenuated (in dB) below the transmitter output power P (dBW) by at least $43 + 10 \log_{10} P(\text{watts})$.
- ii. After the first 1.0 MHz, the emission power in any 1 MHz bandwidth shall be attenuated (in dB) below the transmitter output power P (dBW) by at least $43 + 10 \log_{10} P(\text{watts})$. If the measurement is performed using 1% of the emission bandwidth, power integration over 1.0 MHz is required.

Complies?	Yes
-----------	-----

Diagram 3.1a, WCDMA TM1, LTE: E-TM1.1, Bim_{W+L},
9 kHz – 3 GHz, Port A:

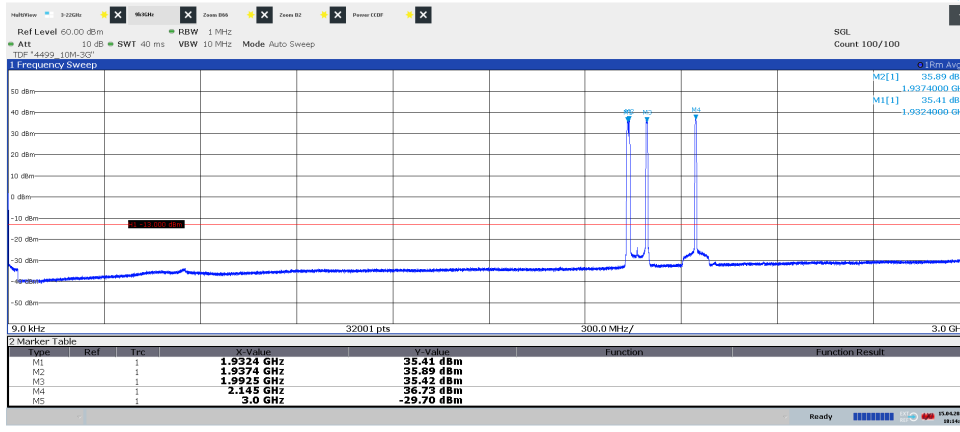

18:14:06 15.04.2020

Diagram 3.1b, WCDMA TM1, LTE: E-TM1.1, Bim_{W+L},
1.8875 GHz – 2.0375 GHz, Port A:

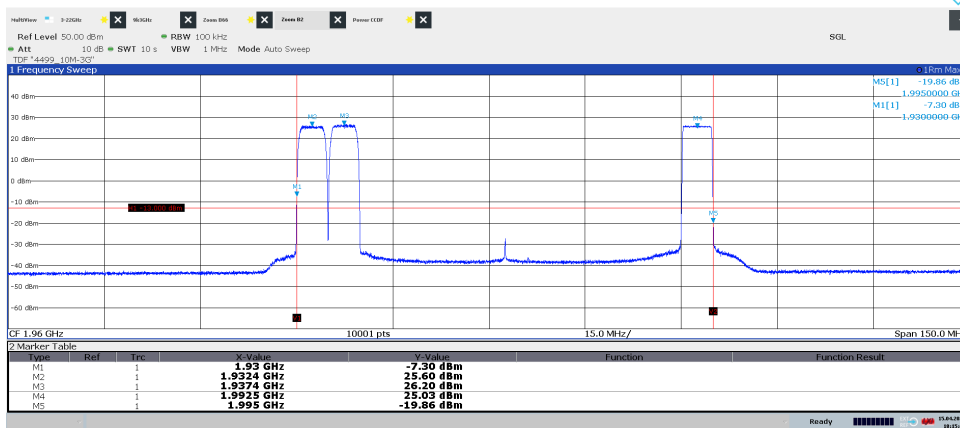

18:15:44 15.04.2020

Note: The purpose of this measurement is to find IM products, not to verify compliance at the Band edges.

Diagram 3.1c, WCDMA TM1, LTE: E-TM1.1, Bim_{W+L},
3 GHz – 22 GHz, Port A:

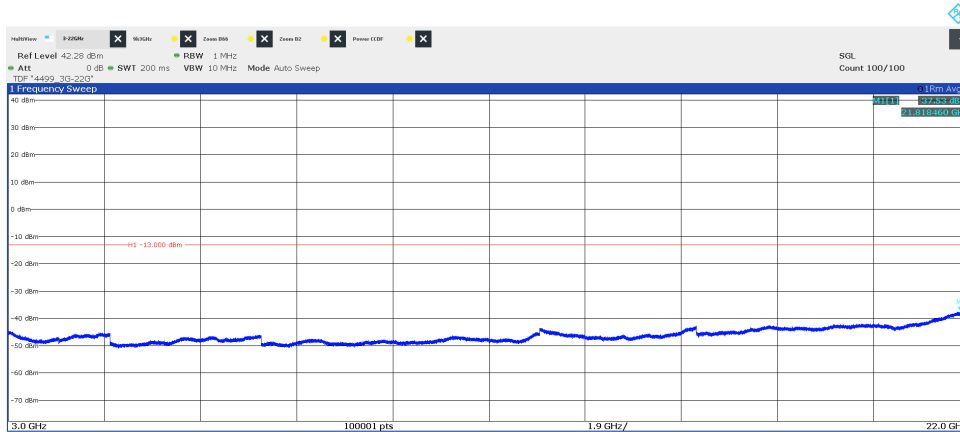

18:11:57 15.04.2020

Diagram 3.2a, WCDMA TM1, LTE: E-TM1.1, Tim_{W+L} ,
9 kHz – 3 GHz, Port A:

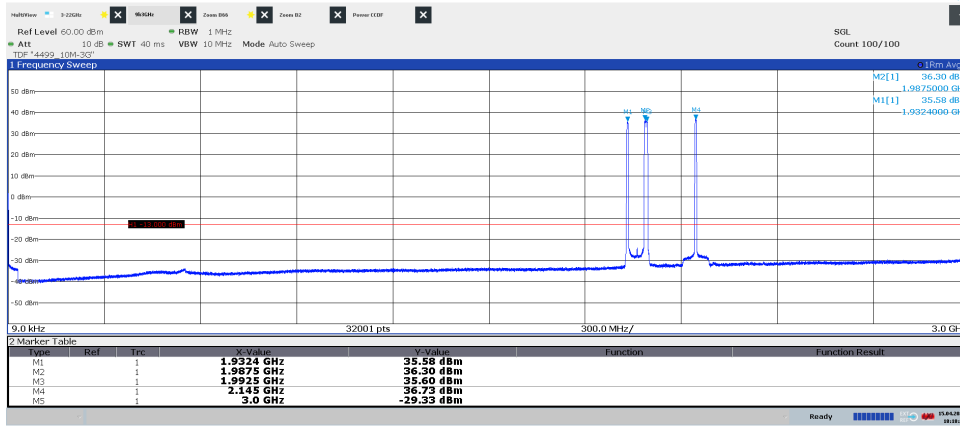
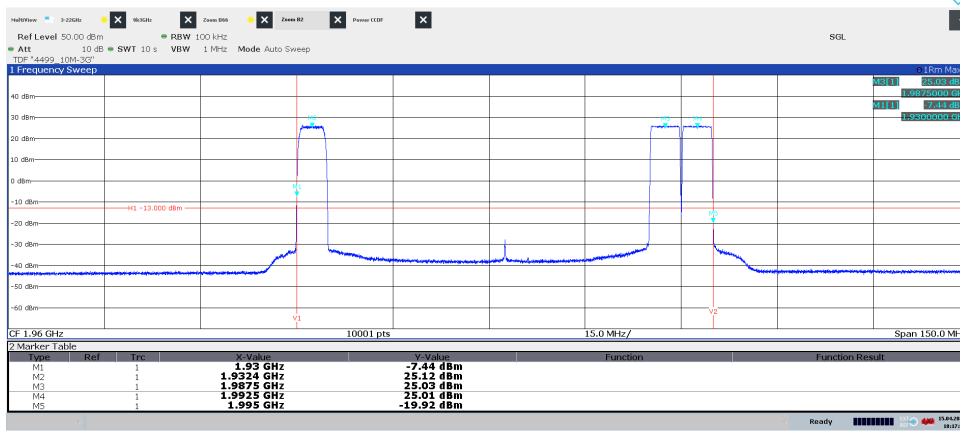

Diagram 3.2b, WCDMA TM1, LTE: E-TM1.1, Tim_{W+L} ,
1.8875 GHz – 2.0375 GHz, Port A:



Note: The purpose of this measurement is to find IM products, not to verify compliance at the Band edges.

Diagram 3.2c, WCDMA TM1, LTE: E-TM1.1, Tim_{W+L} ,
3 GHz – 22 GHz, Port A:

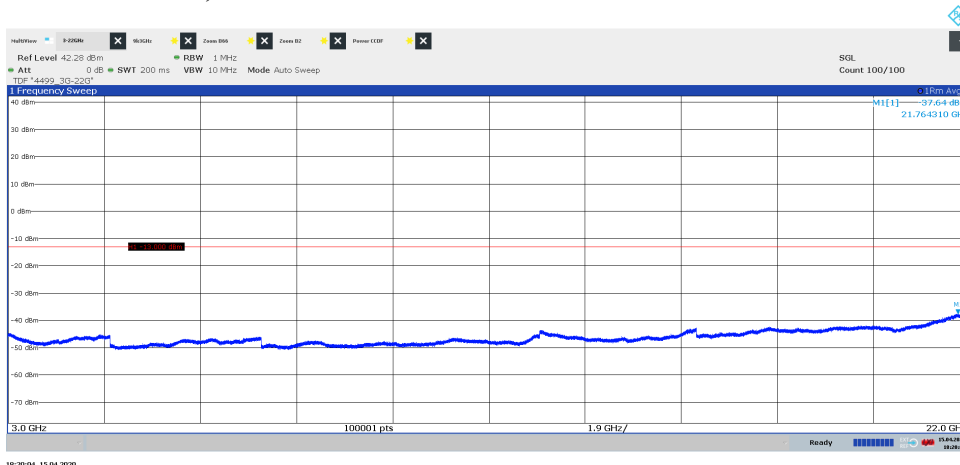

Diagram 3.3a, WCDMA TM1, LTE: E-TM1.1, BMT6,
9 kHz – 3 GHz, Port A:

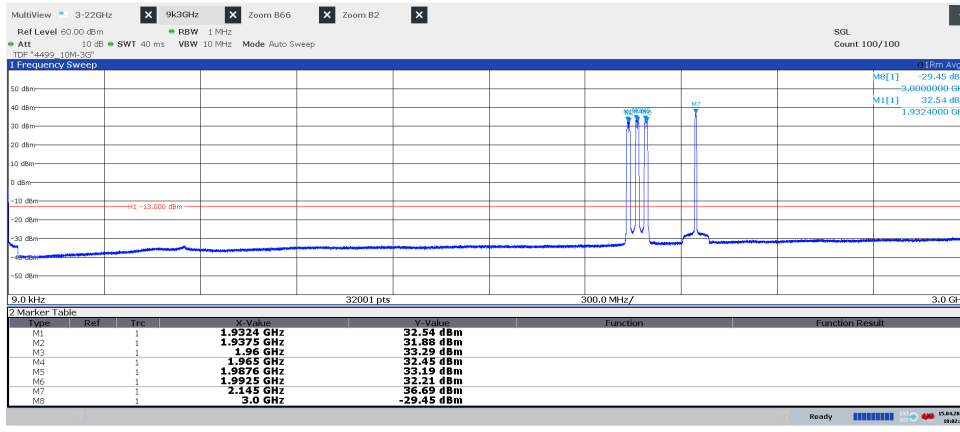
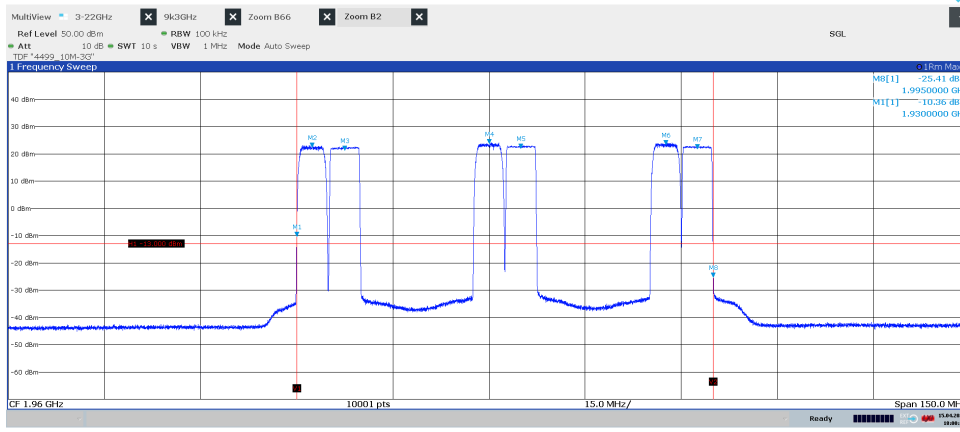

Diagram 3.3b, WCDMA TM1, LTE: E-TM1.1, BMT6,
1.8875 GHz – 2.0375 GHz, Port A:



Note: The purpose of this measurement is to find IM products, not to verify compliance at the Band edges.

Diagram 3.3c, WCDMA TM1, LTE: E-TM1.1, BMT6,
3 GHz – 22 GHz, Port A:

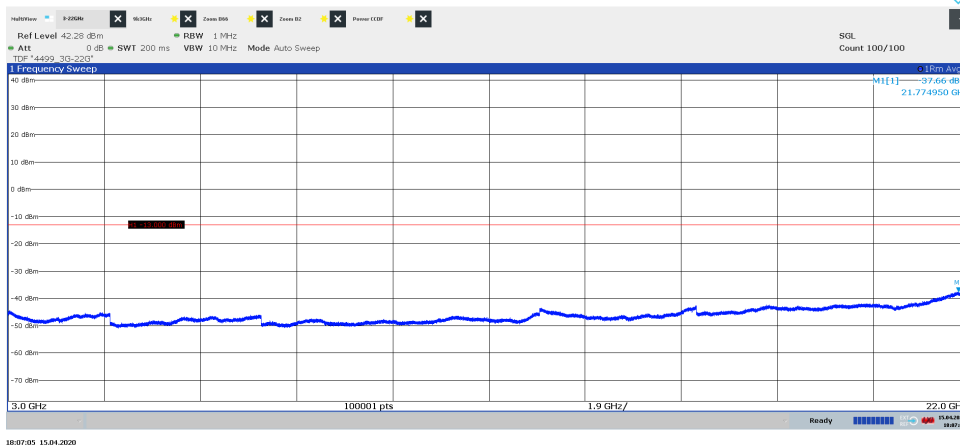
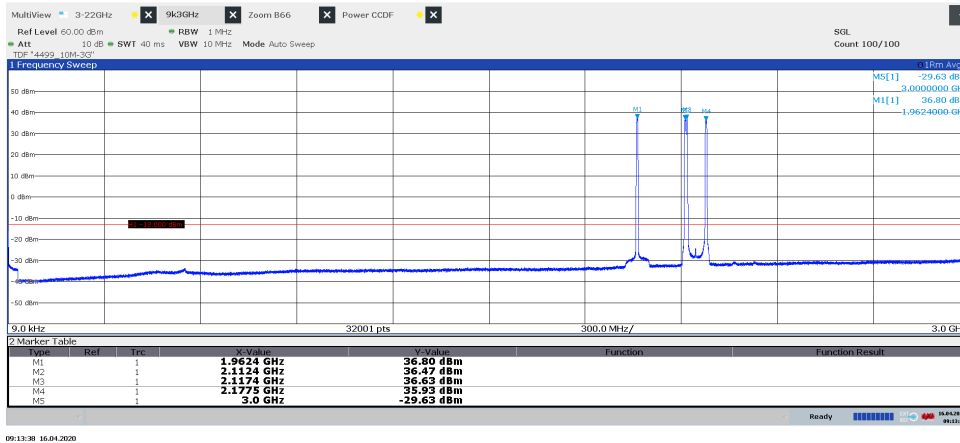
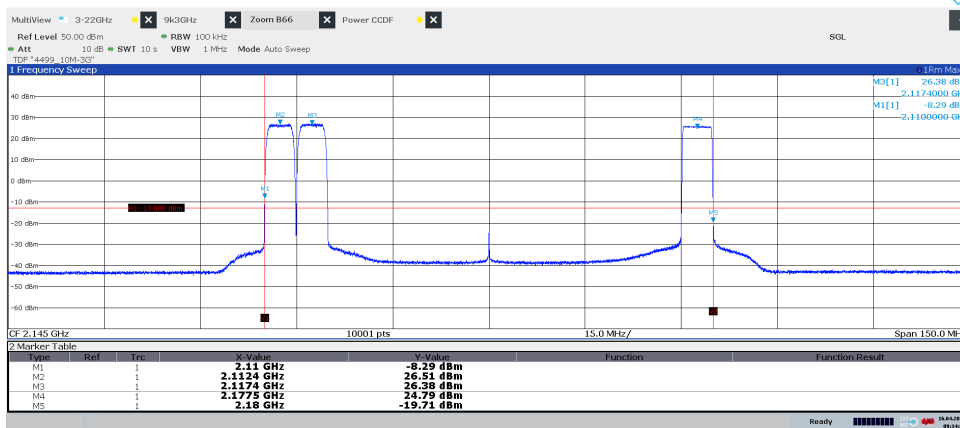

Diagram 3.4a, WCDMA TM1, LTE: E-TM 1.1, Bim_{W+L},
9 kHz – 3 GHz, Port B:



09:13:38 16.04.2020

Diagram 3.4b, WCDMA TM1, LTE: E-TM1.1, Bim_{W+L}
2.070 GHz – 2.220 GHz, Port B:



09:14:09 16.04.2020

Note: The purpose of this measurement is to find IM products, not to verify compliance at the Band edges.

Diagram 3.4c, WCDMA TM1, LTE: E-TM1.1, Bim_{W+L},
3 GHz – 22 GHz, Port B:

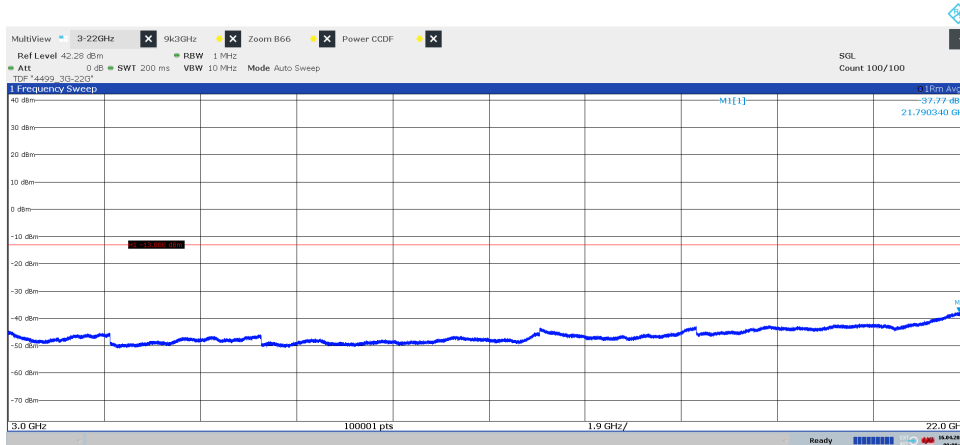

09:08:09 16.04.2020

Diagram 3.5a, WCDMA TM1, LTE: E-TM1.1, T_{imW+L} ,
9 kHz – 3 GHz, Port B:

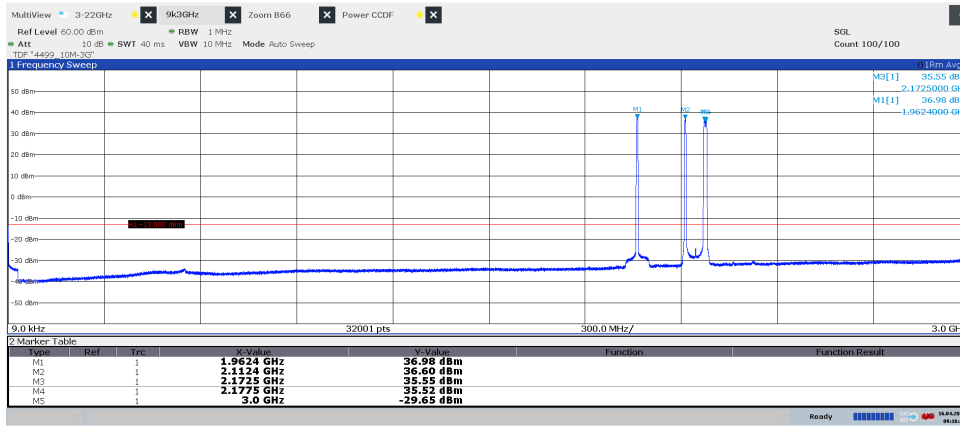

09:16:38 16.04.2020

Diagram 3.5b, WCDMA TM1, LTE: E-TM1.1, T_{imW+L}
2.070 GHz – 2.220 GHz, Port B:

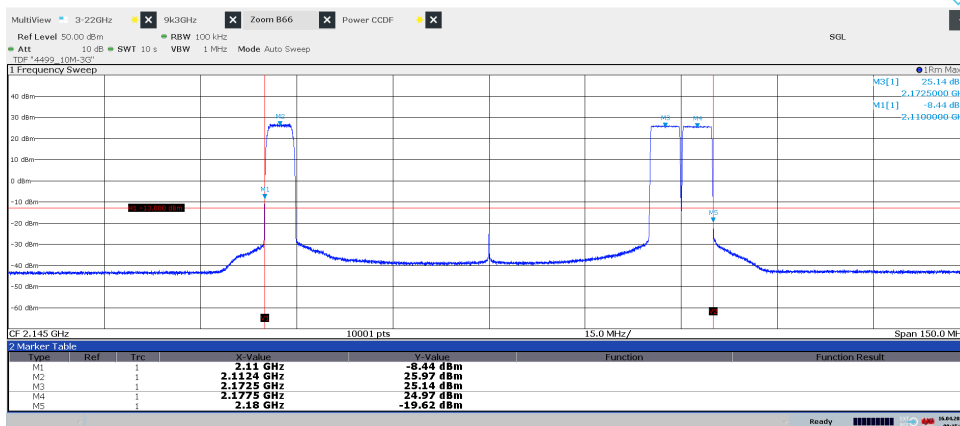

09:15:51 16.04.2020

Note: The purpose of this measurement is to find IM products, not to verify compliance at the Band edges.

Diagram 3.5c, WCDMA TM1, LTE: E-TM1.1, T_{imW+L} ,
3 GHz – 22 GHz, Port B:

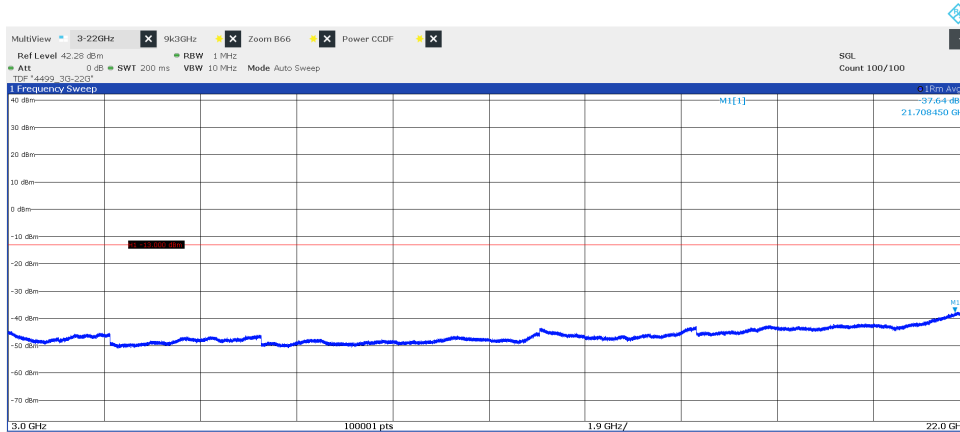

09:22:59 16.04.2020

Diagram 3.6a, WCDMA: TM1, LTE: E-TM1.1, BMT6,
9 kHz – 3 GHz, Port B:

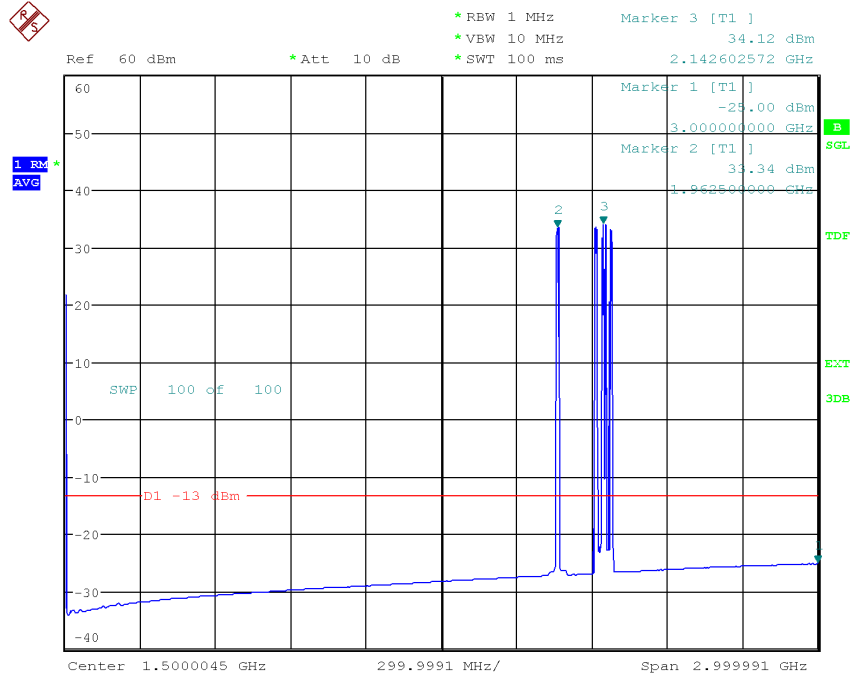

Date: 30.SEP.2020 11:13:46

Diagram 3.6b, WCDMA: TM1, LTE: E-TM1.1, BMT6,
1.935 GHz – 2.205 GHz, Port B:

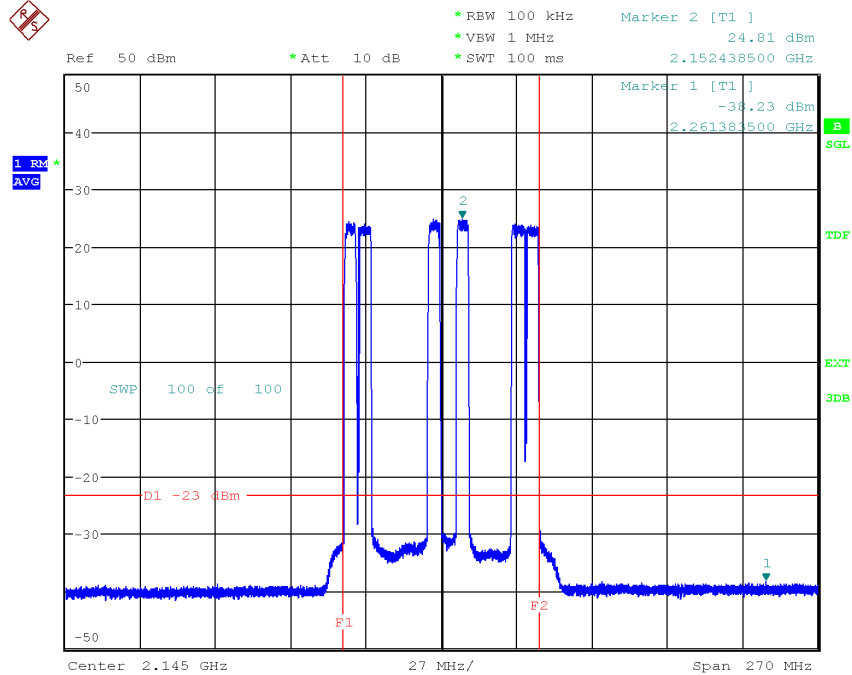

Date: 30.SEP.2020 11:16:36

Note: The purpose of this measurement is to find IM products, not to verify compliance at the Band edges.

Diagram 3.6c, WCDMA: TM1, LTE: E-TM1.1, BMT6,
3 GHz – 9.5 GHz, Port B:

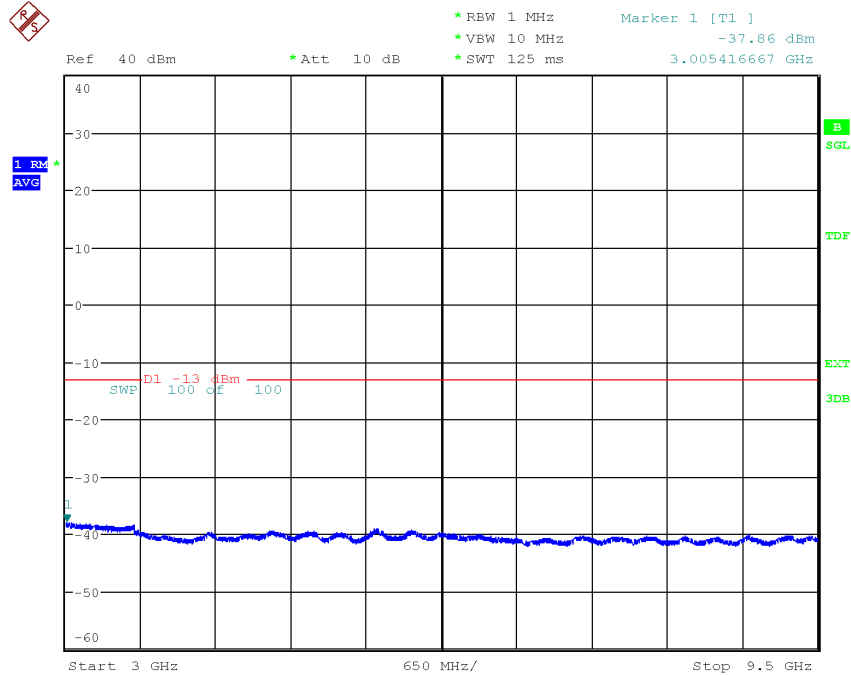

Date: 30.SEP.2020 11:26:03

Diagram 3.6d, WCDMA: TM1, LTE: E-TM1.1, BMT6,
9.5 GHz – 16 GHz, Port B:

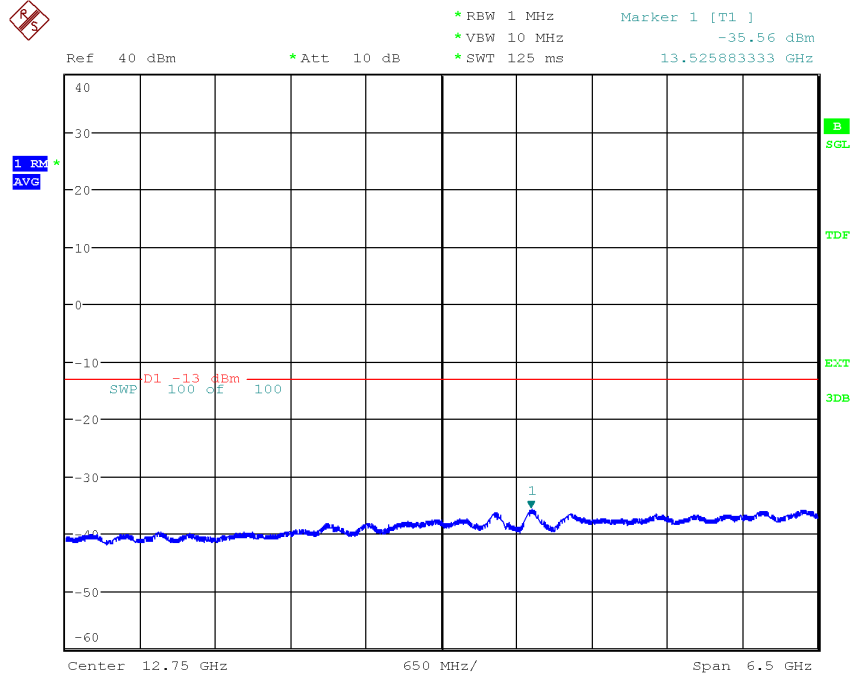

Date: 30.SEP.2020 11:28:27

Diagram 3.6e, WCDMA: TM1, LTE: E-TM1.1, BMT6,
16 GHz – 22 GHz, Port B:

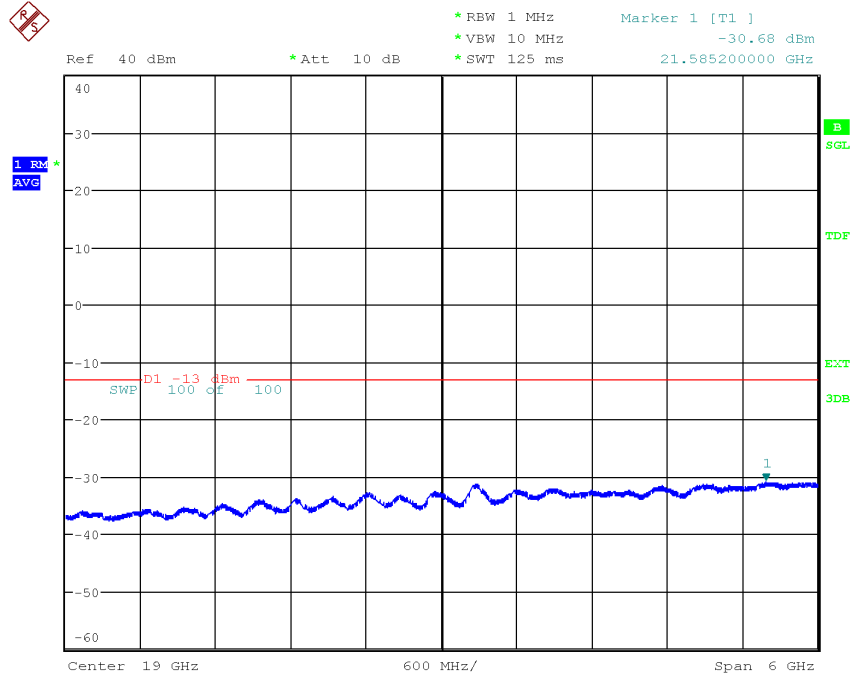

Date: 30.SEP.2020 11:33:27

Diagram 3.7a, WCDMA: TM1, LTE: E-TM1.1, Bim_{W+L+IoT},
9 kHz – 3 GHz, Port A:

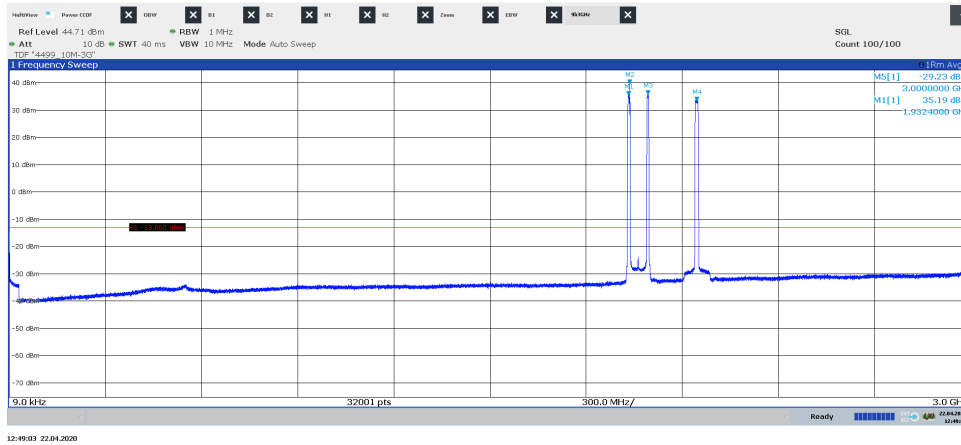
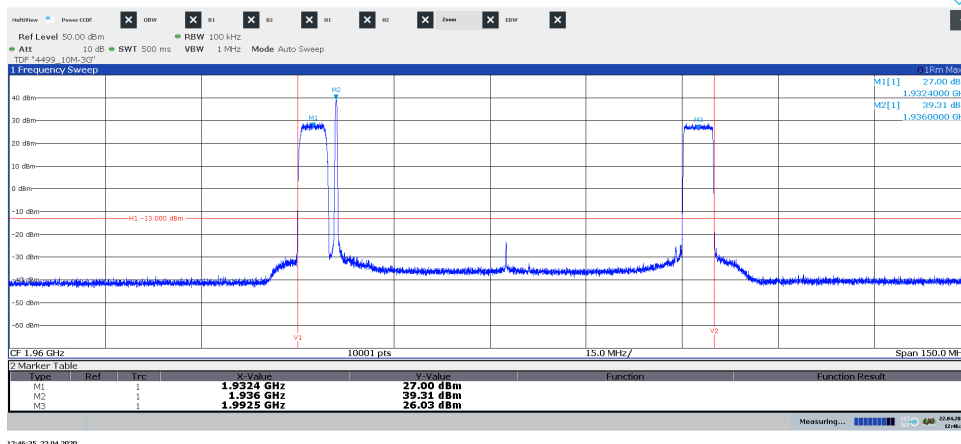

Diagram 3.7b, WCDMA: TM1, LTE: E-TM1.1, Bim_{W+L+IoT},
1.8875 GHz – 2.0375 GHz, Port A:



12:46:35 22.04.2020

Note: The purpose of this measurement is to find IM products, not to verify compliance at the Band edges.

Diagram 3.7c, WCDMA: TM1, LTE: E-TM1.1, Bim_{W+L+IoT},
3 GHz – 22 GHz, Port A:

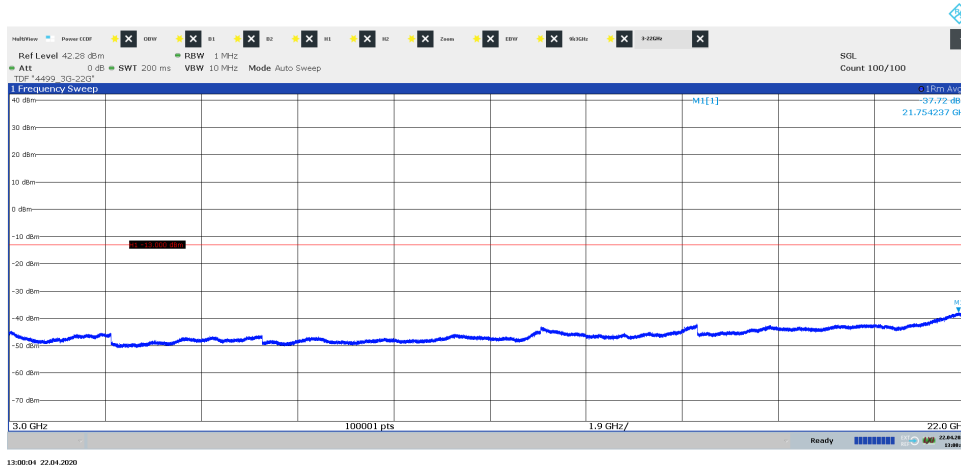

13:00:04 22.04.2020

Diagram 3.8a, WCDMA: TM1, LTE: E-TM1.1, $T_{imW+L+IoT}$, 9 kHz – 3 GHz, Port A:

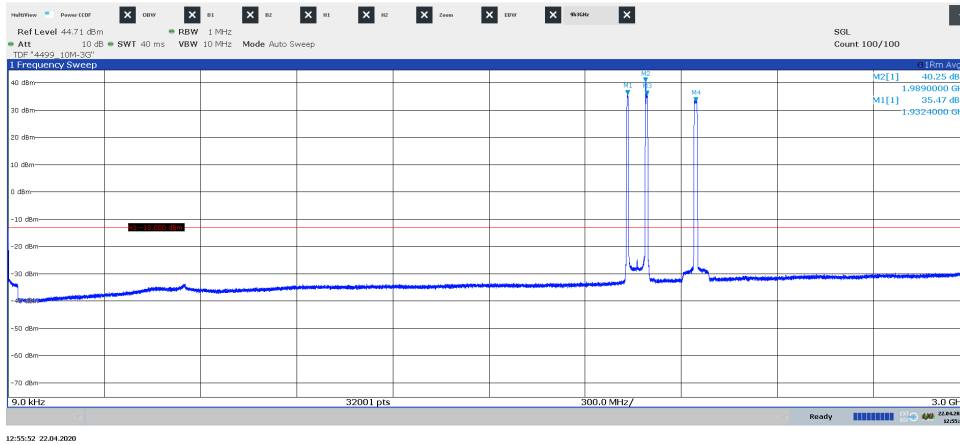
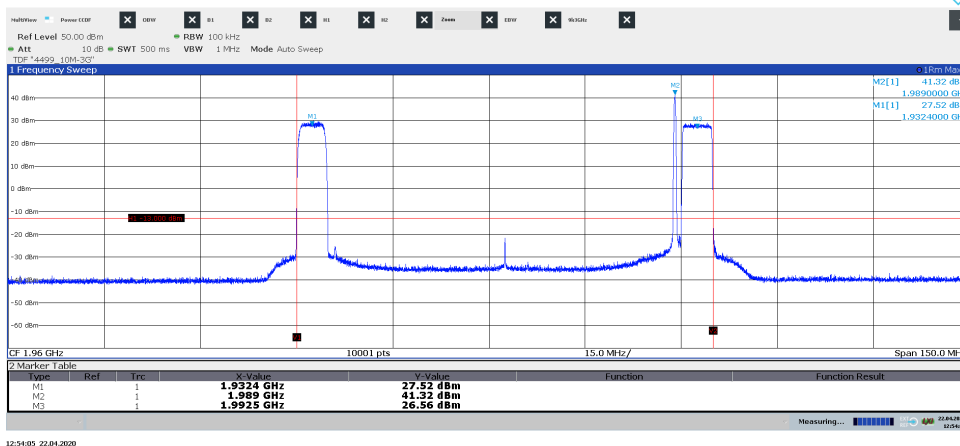

Diagram 3.8b, WCDMA: TM1, LTE: E-TM1.1, $T_{imW+L+IoT}$, 1.8875 GHz – 2.0375 GHz, Port A:



Note: The purpose of this measurement is to find IM products, not to verify compliance at the Band edges.

Diagram 3.8c, WCDMA: TM1, LTE: E-TM1.1, $T_{imW+L+IoT}$, 3 GHz – 22 GHz, Port A:

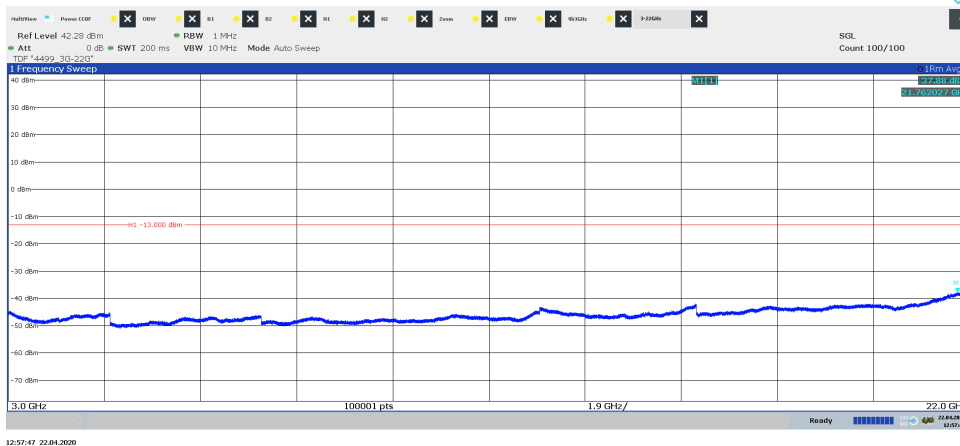

Diagram 3.9a, WCDMA: TM1, LTE: E-TM1.1, $B_{imW+L+IoT}$, 9 kHz – 3 GHz, Port B:

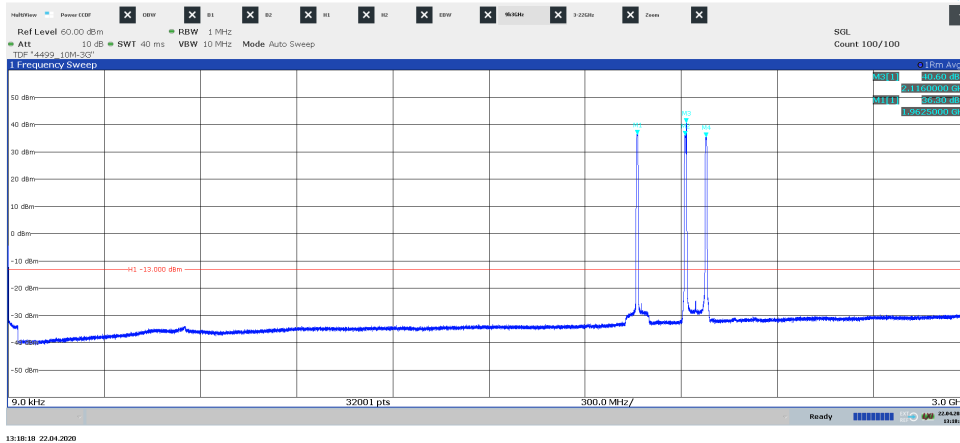
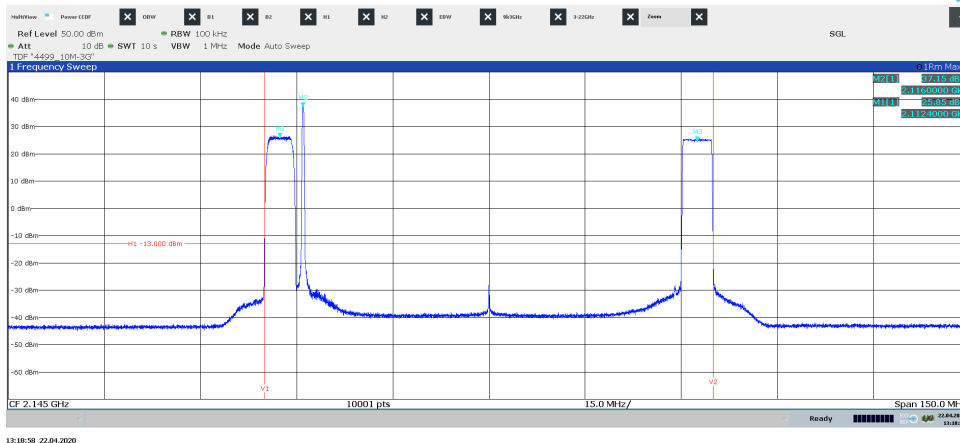

Diagram 3.9b, WCDMA: TM1, LTE: E-TM1.1, $B_{imW+L+IoT}$, 2.070 GHz – 2.220 GHz, Port B:



Note: The purpose of this measurement is to find IM products, not to verify compliance at the Band edges.

Diagram 3.9c, WCDMA: TM1, LTE: E-TM1.1, $B_{imW+L+IoT}$, 3 GHz – 22 GHz, Port B:

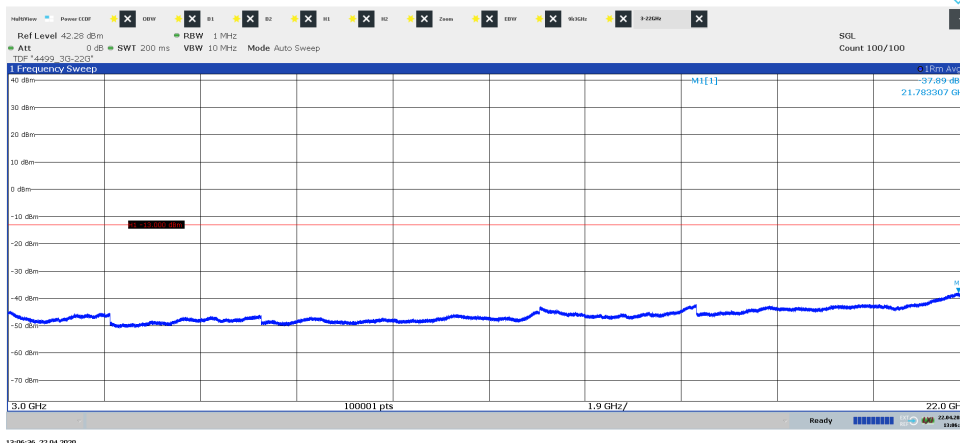

Diagram 3.10a, WCDMA: TM1, LTE: E-TM1.1, $T_{imW+L+IoT}$, 9 kHz – 3 GHz, Port B:

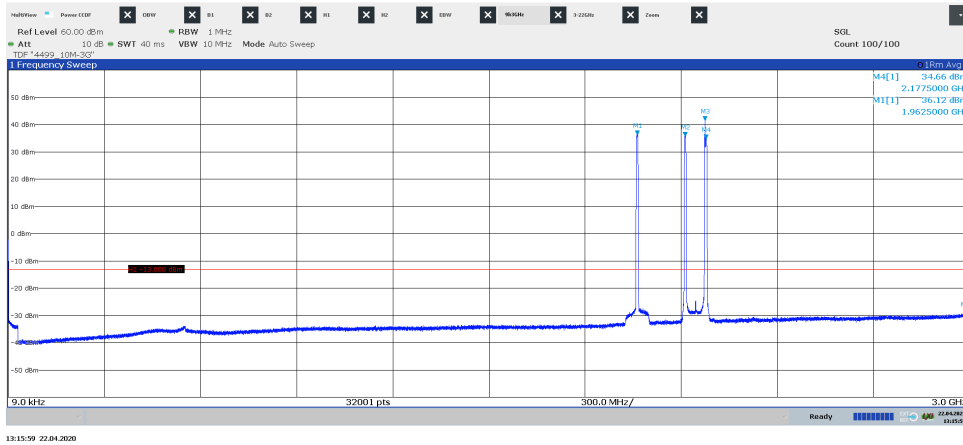
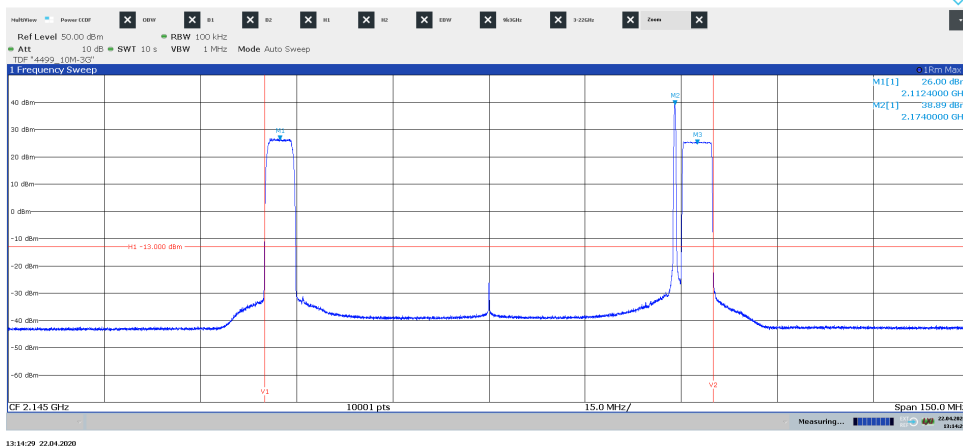
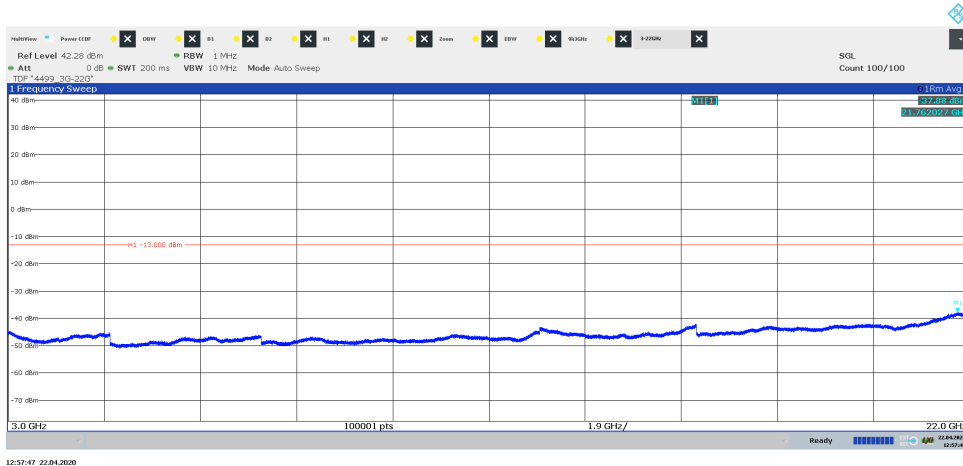

Diagram 3.10b, WCDMA: TM1, LTE: E-TM1.1, $T_{imW+L+IoT}$, 2.070 GHz – 2.220 GHz, Port B:



Note: The purpose of this measurement is to find IM products, not to verify compliance at the Band edges.

Diagram 3.10c, WCDMA: TM1, LTE: E-TM1.1, $T_{imW+L+IoT}$, 3 GHz – 22 GHz, Port B:



Field strength of spurious radiation measurements according to CFR 47 §24.238 and §27.53(h) / RSS-133 6.5, RSS-139 6.6

Date	Temperature	Humidity
2020-02-27	22 °C ± 3 °C	20 % ± 5 %
2020-02-28	22 °C ± 3 °C	19 % ± 5 %
2020-10-05	23 °C ± 3 °C	48 % ± 5 %

The test site conforms to the site validation criterion specified in ANSI C63.4.

The measurements were performed with both horizontal and vertical polarization of the antenna. The antenna distance and test object height in the different frequency ranges can be seen below.

The antenna distance was 3 m in the frequency range 30 MHz – 18 GHz and 1 m in the frequency range 18 GHz – 22 GHz.

The EUT was placed 0.8 m above reference ground plane in frequency range 30 MHz – 1 GHz and 1.5 m above reference ground plane in frequency range 1 GHz – 22 GHz.

The measurement was performed with an RBW of 1 MHz.

A propagation loss in free space was calculated. The used formula was

$$\gamma = 20 \log \left(\frac{4\pi D}{\lambda} \right), \gamma \text{ is the propagation loss and } D \text{ is the antenna distance.}$$

The measurement procedure was as the following:

1. A pre-measurement is performed with peak detector. For measurement < 1 GHz the test object was measured in eight directions with the antenna at three heights, 1.0 m, 1.5 m and 2.0 m. For measurements > 1 GHz the test object was measured in seventeen directions with the antenna height 1.5 m, 2.0 m and 2.5 m with elevation angle.
2. Spurious radiation on frequencies closer than 20 dB to the limit in the pre-measurement is scanned 0-360 degrees and the antenna is scanned 1- 4 m for maximum response. The emission is then measured with the RMS detector and the RMS value is reported. Frequencies closer than 10 dB to the limit when measured with the RMS detector were measured with the substitution method according to ANSI 63.26.

The test set-up during the spurious radiation measurements is shown in the pictures below:

Test setup 30-1000 MHz:

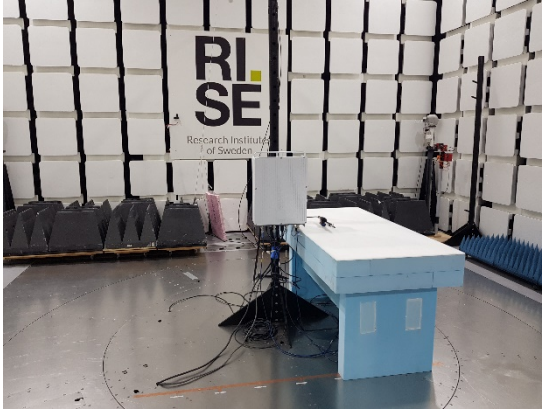

Test setup 1-18 GHz:

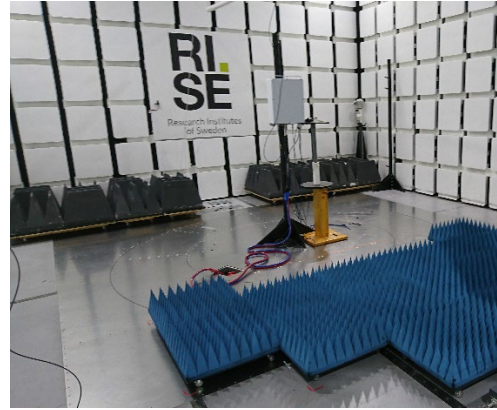

Test setup 18-22 GHz:

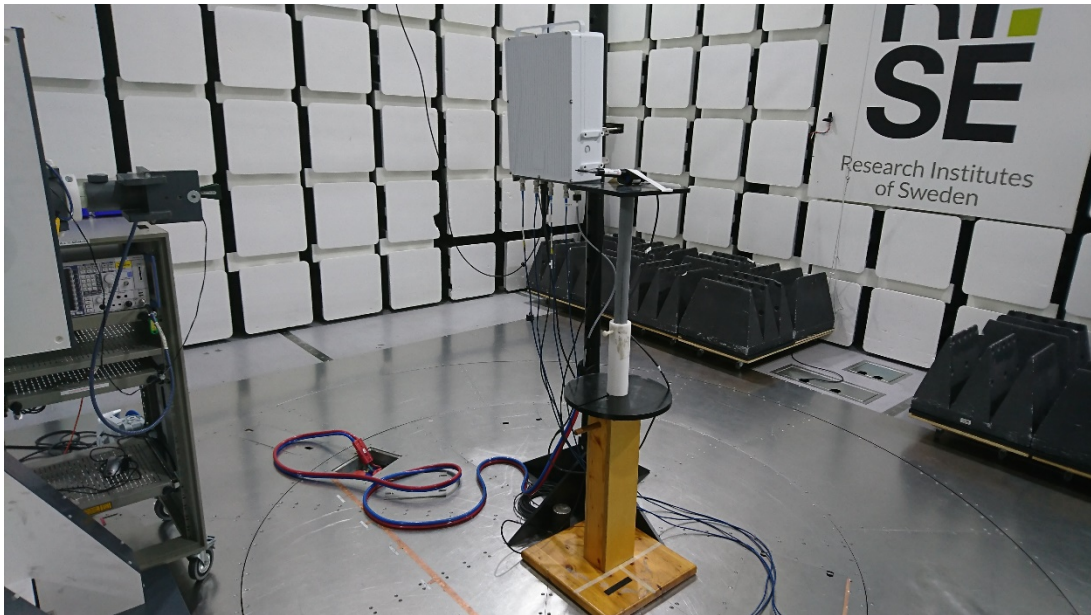

Measurement equipment

Measurement equipment	RISE number
Test site Tesla	503 881
R&S ESU 40	901 385
Control computer with R&S software EMC32 version 10.60.10	BX62351
High pass filter 3-18 GHz	BX40074
Flann Standard Gain Horn 20240-20	BX92412
Teseq BiConiLog Antenna CBL6143A	BX92331
Coaxial cable, Tesla emission	BX91490
Coaxial cable	503 508
Coaxial cable	503 509
EMCO Horn Antenna 3115	502 175
µComp Nordic, Low Noise Amplifier	901 545
Miteq, Low Noise Amplifier	503 278
Temperature and humidity meter, Testo 625	504 188

Results

Tested configurations: W+L top configuration
representing worst case: Symbolic name T_{W+L} , TM 1, E-TM1.1, Diagram 1 a-d

Frequency (MHz)	Spurious emission level (dBm)	
	Vertical	Horizontal
30-22000	All emission > 20 dB below limit	All emission > 20 dB below limit

Measurement uncertainty: 3.1 dB

Limits

CFR 47 §24.238 and §27.53(h)

Outside a licensee's frequency band(s) of operation the power of any emission shall be attenuated below the transmitter power (P) by at least $43 + 10 \log_{10}(P)$ dB. resulting in a limit of -13 dBm.

Complies?	Yes
-----------	-----

Diagram 4.1a:

Full Spectrum

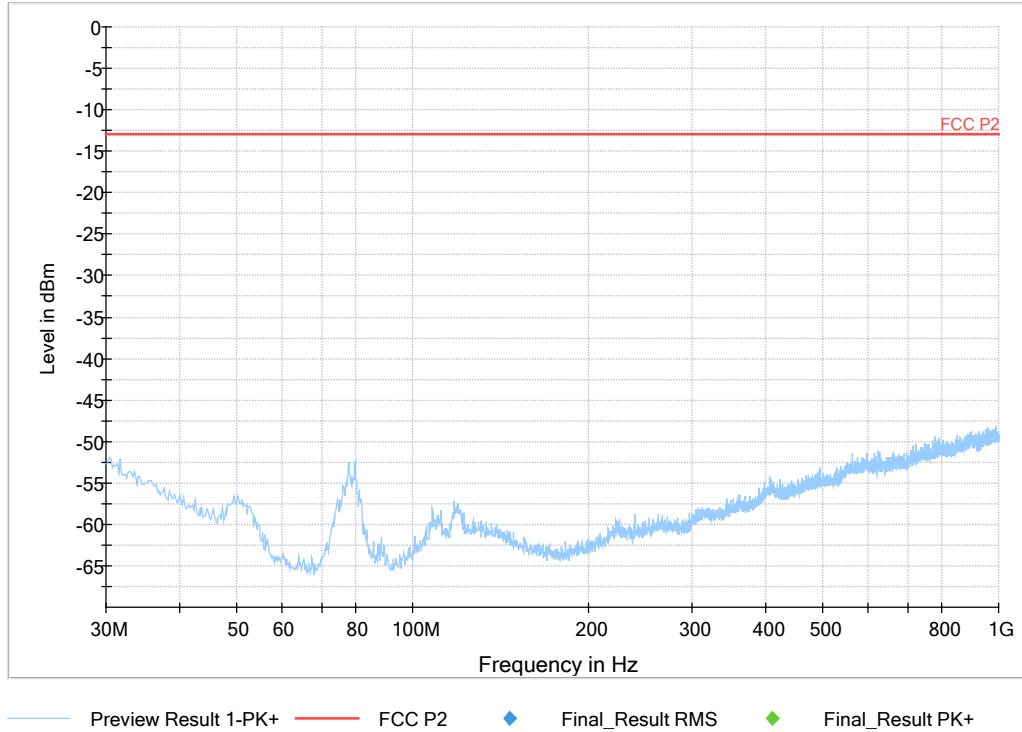
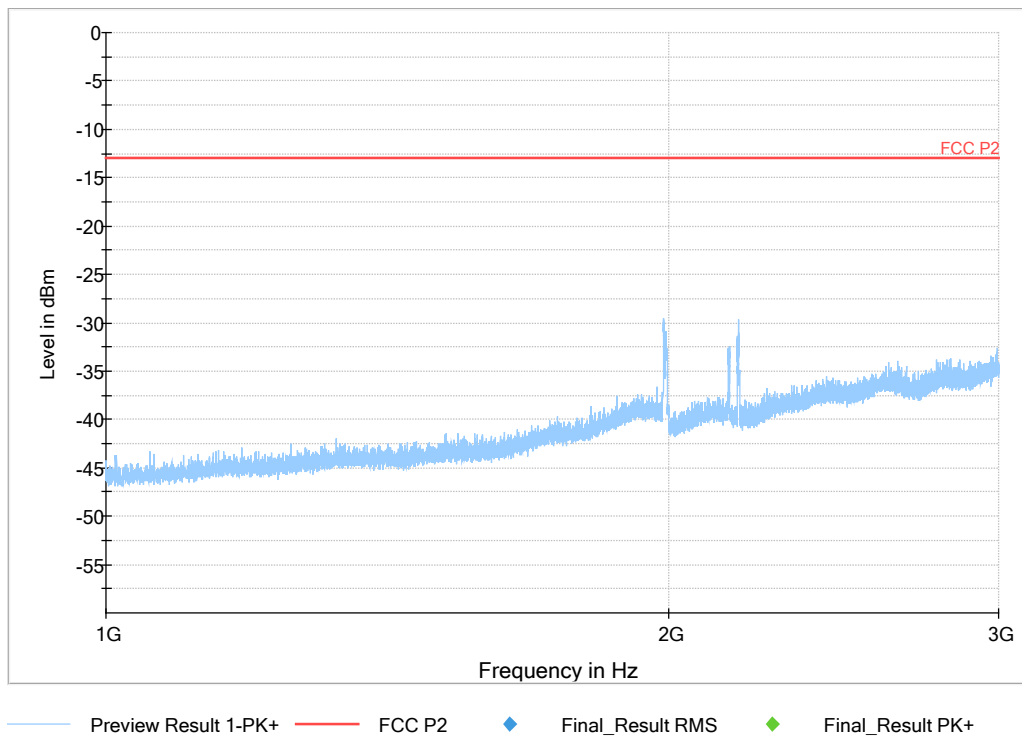

Diagram 4.1b:

Full Spectrum



Note: The emissions at 1987.5 MHz, 1992.6 MHz, 2152.6 and 2177.5 MHz are the carrier frequencies and shall be ignored in the context.

Diagram 4.1c:

Full Spectrum

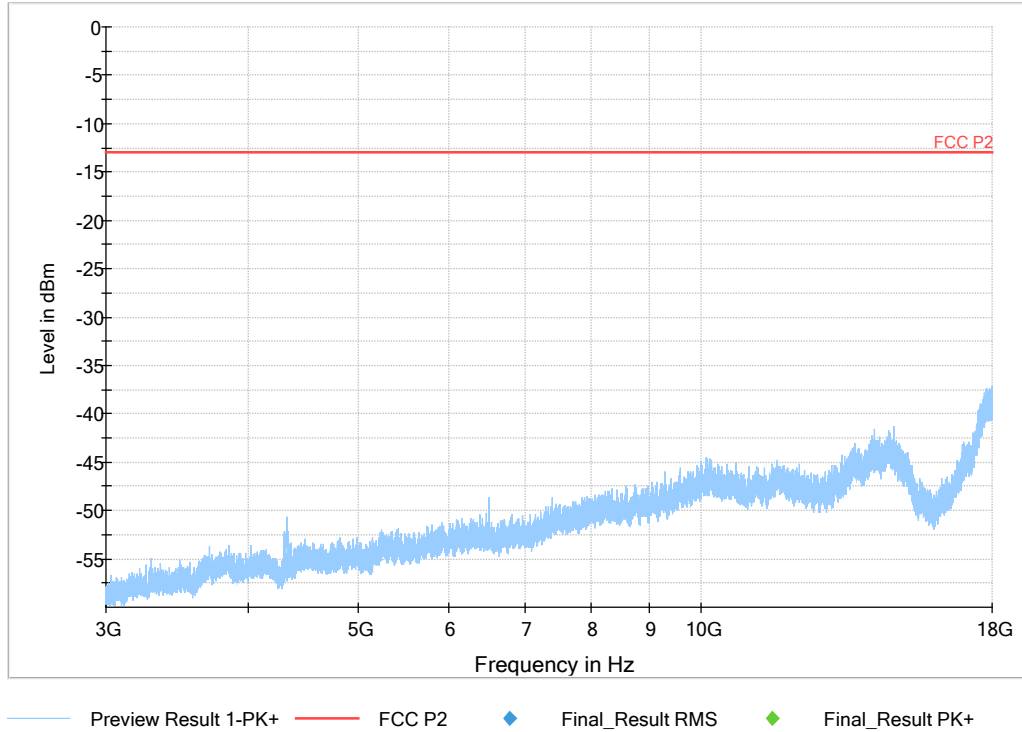
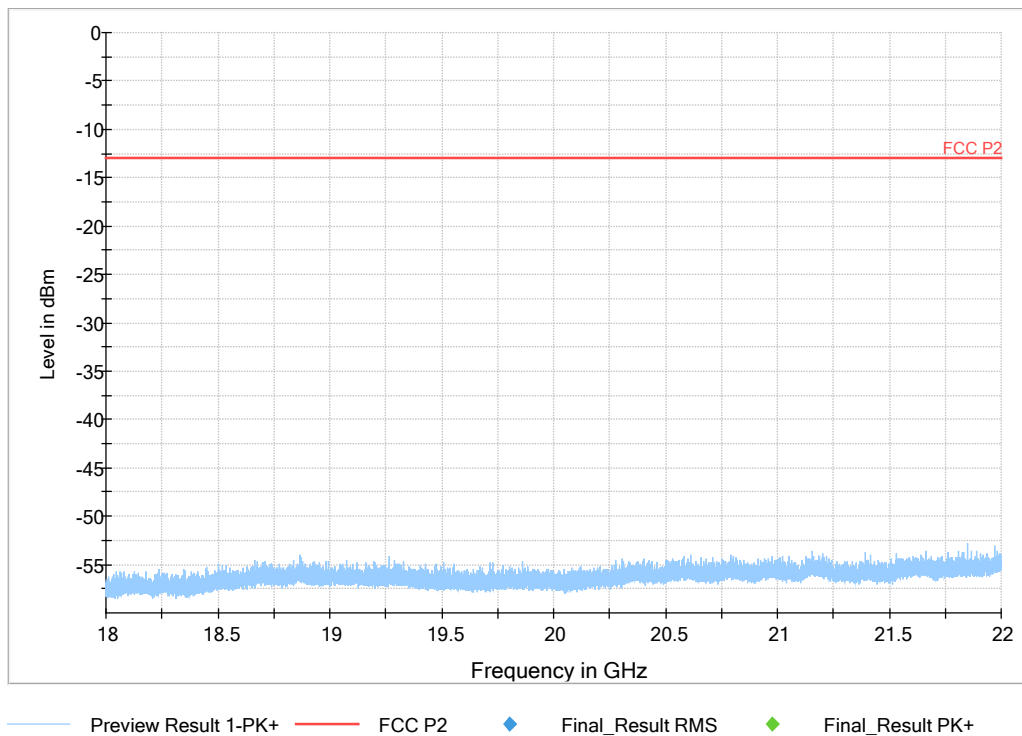

Diagram 4.1d:

Full Spectrum



Photos of test object

Front side



Rear side



Left side



Right side



Bottom side



Top side



Labels:

Radiated measurements:

Test object label:

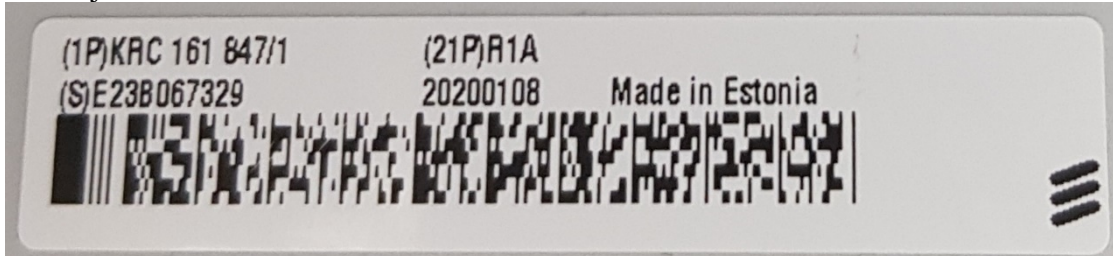

SFP module Data 1:



SFP module Data 2:



Conducted measurements:

Test object label:

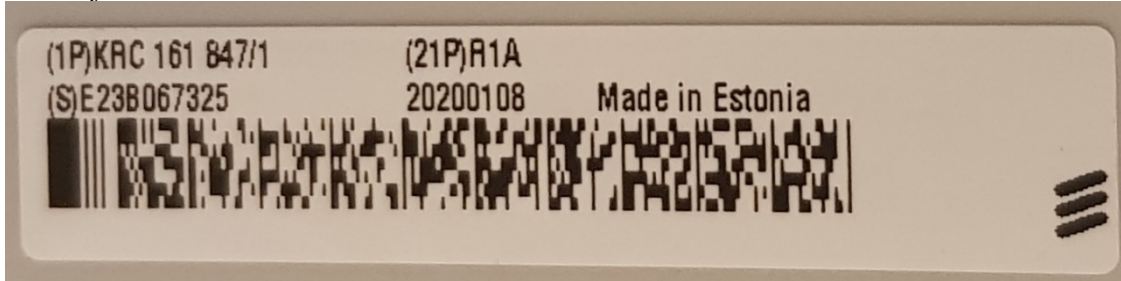

SFP module Data 1:



SFP module Data 2:



End of report.