

 <p>Accred. no. 1761 Testing ISO/IEC 17025</p>	<p>Test report issued by an Accredited Testing Laboratory</p>
---	--

EMF Test Report: Ericsson Radio 4408 B48 (FCC)

Document number:	GFTL-19:000863 Uen Rev B	Date of report:	2021-12-06
Testing laboratory:	Ericsson EMF Research Laboratory Ericsson AB SE-164 80 Stockholm Sweden	Company/Client:	Bruce Wang W CBC - Ericsson (China) Communications Co. Ltd. ET2, No.5 Lize East street Chaoyang District 100102 Beijing China
Tests performed by:	Davide Colombi	Dates of tests:	2019-08-16 (Rev A) 2021-11-26 (Rev B)
Manufacturer and market name(s) of device:	Ericsson Radio 4408 B48		
Testing has been performed in accordance with:	FCC OET Bulletin 65 IEC 62232:2017		
Test results:	RF exposure compliance boundaries (exclusion zones) related to the limits in FCC 47 CFR 1.1310 to be included in the Customer Product Information (CPI) for Ericsson Radio 4408 B48.		
Additional information:			
Signature:	Test Engineer  <hr/> Davide Colombi Master Researcher davide.colombi@ericsson.com Tel: +46 767602089	Laboratory and Quality Manager  <hr/> Christer Törnevik Senior Expert – EMF and Health christer.tornevik@ericsson.com Tel: +46 705863148	

Summary of EMF Test Report¹

Equipment under test (EUT)

Product name	Radio 4408 B48		
Product number	KRC 161 746/1		
Supported bands, Tx frequency range (MHz) and standards	B48	3550–3700	LTE, NR
Duplexing technology and fraction of downlink transmission time to total time	TDD (75%)		
Exposure environment	General public/uncontrolled, Occupational/controlled		

Results

RF exposure compliance boundaries, outside of which the exposure is below the general public (GP) and occupational (O) exposure limits, are listed below.

Dimensions of the box-shaped compliance boundary for general public (GP) and occupational (O) exposure for Radio 4408 B48 applicable in the markets employing the FCC exposure limits. The compliance boundaries are determined for maximum output power with 0.6 dB output power tolerance and TDD downlink duty cycle included.

Mode and output power for Radio 4408 B48					Dimensions of the box-shaped compliance boundary (m)							
					Distance in front of EUT		Width		Height		Distance behind EUT	
Band	Standard	Single/Dual Radio version	Nominal output power from the radio	TDD DL duty cycle	GP	O	GP	O	GP	O	GP	O
B48	LTE, NR	Single	4 × 5 W	75%	2.1	0.9	1.7	0.8	1.2	0.7	0.2	0.2
B48	LTE, NR	Dual	4 × 5 W + 4 × 5 W	75%	2.9	1.3	2.4	1.1	2.0	1.1	0.2	0.2

For the power levels specified in the table with tolerances added, and the upward rounding of compliance boundary dimensions to the nearest decimeter, the specified results are conservative.

¹ This page contains a summary of the test results. The full report provides a complete description of all test details and results.

1 General information

The test results presented in this report define compliance boundaries for Radio 4408 B48. Outside of these compliance boundaries, the radio frequency (RF) exposure levels are below the limits specified by the Federal Communications Commission (FCC) [1]. The tests were performed by calculations in accordance with the Ericsson RF exposure calculation procedure for base stations [2], which is in conformity with the FCC OET Bulletin 65 [3] and IEC 62232:2017 [4].

It should be noted that the test results presented in this test report are valid for the frequency range specified in Table 1, for the antenna properties specified in Table 2, and for the power level and the power tolerance specified in Table 3. These data as well as the applied antenna pattern files were supplied by the client and may affect the validity of the results.

Proposed EMF health and safety information for inclusion in the Customer Product Information (CPI) is provided in Appendices A, B and C.

2 Equipment under test

Table 1 and Table 2 below summarize the technical data for the equipment under test (EUT) and the properties of the integrated antenna. Table 3 lists the maximum nominal output power from the radio unit (total peak power from all antenna branches) and the total time-averaged power delivered to the antenna for the specified configurations. The total time-averaged power delivered to the antenna includes output power tolerance and the TDD downlink duty cycle.

The EUT was tested for both Single Radio and Dual Radio versions shown in Appendix D. In the Single Radio version, each radio unit has its own power supply unit, while in the Dual Radio version one power supply unit can support two radios.

The EUT related data in Tables 1-3 were supplied by the client.

Table 1 Technical data for the EUT.

Product name and product number	Radio 4408 B48	KRC 161 746/1	
Supported bands, Tx frequency range (MHz), and standards	B48	3550–3700	LTE, NR
Antenna	KRE 105 281/1		
Duplexing technology	TDD		
Dimensions, $H \times W \times D$ (mm)	213.5 x 200 x 125 (Single radio including power supply and antenna) 449 x 200 x 130 (Dual radio including power supply and antennas)		
Exposure environment	General public/uncontrolled, Occupational/controlled		
IEC 62232 installation class [4]	E+		

Table 2 Properties of the antenna.

Product number	KRE 105 281/1
Type	Internal antenna, directional, 4 Tx
Tested band and frequency range (MHz)	3550–3700
Gain (dBi)²	12.06
Electrical downtilt angle (degree)	8

² Maximum gain per antenna port obtained using the antenna patterns provided by the antenna manufacturer.

Table 3 EUT configurations with maximum nominal output power levels and total time-averaged power levels including output power tolerance and TDD downlink duty cycle.

Band	Standard	Single/Dual Radio version	Nominal total output power (dBm/W)	Power tolerance (dB)	TDD downlink duty cycle	Total time-averaged power delivered to antennas (dBm/W)
B48	LTE, NR	Single	43.0 / 20	0.6	75%	42.3 / 17.0
B48	LTE, NR	Dual	46.0 / 40	0.6	75%	45.3 / 34.0

3 Exposure conditions

The EUT is intended to be installed on walls, poles, ceilings, and similar structures making it possible to ensure that the general public has no access to the EMF compliance boundary. Other installation related exposure conditions are not reasonably foreseeable for the EUT.

The assessments were conducted for maximum power configurations, i.e., by assuming 100% utilization. Effects of real RBS utilization (time-averaged) is reasonably foreseeable and will significantly reduce the time-averaged power and the RF exposure. This factor was not considered in this assessment, which adds to the conservativeness of the obtained compliance boundaries.

4 EMF compliance boundary calculations

The RF exposure was evaluated using calculations performed according to the Ericsson RF Exposure Calculation Procedure for Base Stations [2], which conforms to FCC OET Bulletin 65 [3] and IEC 62232 [4]. The calculations were made using the far-field spherical formula. The first step in calculating the compliance boundary was to use the spherical far-field formula to estimate power density:

$$S_{\text{sph}}(\theta, \phi) = \frac{P_a G(\theta, \phi)}{4\pi r^2},$$

where S, P_a, G, r, θ , and ϕ denote the power density, the power accepted by each antenna port, the antenna gain per port, the distance from the antenna, and the angular variables in a spherical coordinate system, respectively. Antenna far-field measurement data were provided by the client for four frequencies, specifically 3550 MHz, 3600 MHz, 3650 MHz and 3700 MHz within Band 48. The procedure described in this session was applied to each of these, and the compliance boundaries were determined as the maximum values for the tested frequencies. The maximum gain values were found to be 11.68 dBi (port A, pol. -45), 12.06 dBi (port B, pol. +45), 11.94 dBi (port C, pol. -45), and 11.74 dBi (port D, pol. +45), considering all the tested frequencies.

The accepted power per port was taken as the total power delivered to the antenna, including tolerances, divided by the number of ports. In the frontal hemisphere ($\phi \in [-\frac{\pi}{2}, \frac{\pi}{2}]$), the exposure from antenna ports with the same nominal polarizations (denoted ± 45) were summed in a correlated way to consider spatial multiplexing while the exposure from antenna ports with different nominal polarizations were summed in an uncorrelated manner. Also, in the rear hemisphere ($\phi \notin [-\frac{\pi}{2}, \frac{\pi}{2}]$), uncorrelated exposure was assumed [2]. With the two antenna panels denoted 1 and 2, the total power density as estimated by the spherical far-field formula is thus given by

$$S_{\text{total,sph}} = \begin{cases} \left(\sqrt{S_{\text{sph},1,+45}} + \sqrt{S_{\text{sph},2,+45}} \right)^2 + \left(\sqrt{S_{\text{sph},1,-45}} + \sqrt{S_{\text{sph},2,-45}} \right)^2, & \phi \in \left[-\frac{\pi}{2}, \frac{\pi}{2}\right] \\ S_{\text{sph},1,+45} + S_{\text{sph},2,+45} + S_{\text{sph},1,-45} + S_{\text{sph},2,-45} & \phi \notin \left[-\frac{\pi}{2}, \frac{\pi}{2}\right] \end{cases}$$

The compliance distance for the spherical model, $CD_{\text{sph}}(\theta, \phi)$ was obtained by solving the following equation for r :

$$\frac{S_{\text{total,sph}}(r, \theta, \phi)}{S_{\text{gp},0}^{\text{lim}}} = 1,$$

where $S_{\text{gp},0}^{\text{lim}}$ denotes the FCC power density limits for general public and occupational exposure. For the frequency bands of interest, RF EMF exposure limits are given in [1].

Table 4 RF EMF exposure limits on power density for the frequency band used by the EUT [1].

Band	S_{gp}^{lim} (W/m ²)	S_o^{lim} (W/m ²)
B48 (3600)	10	50

Based on the calculated compliance distances, a box-shaped compliance boundary was determined. To comply with the FCC requirement of a minimum test separation distance for a non-portable device of 20 cm, the minimum distance from the EUT to the compliance boundary was set to 20 cm.

Since antenna far-field data provided by the client correspond to the Single Radio version, compliance boundaries for the Dual Radio version were obtained in a conservative way by doubling the RF exposure for the Single Radio version. To take into consideration the actual placement of radios in the Dual Radio version (see Appendix D), the distance between the centers of the two radios was added in the obtained compliance boundary height.

5 Results

A box-shaped compliance boundary is used, characterized by its width, height, and the compliance distances behind and in front of the EUT, see Figure 1. Outside of this box, the RF exposure is below the exposure limits.

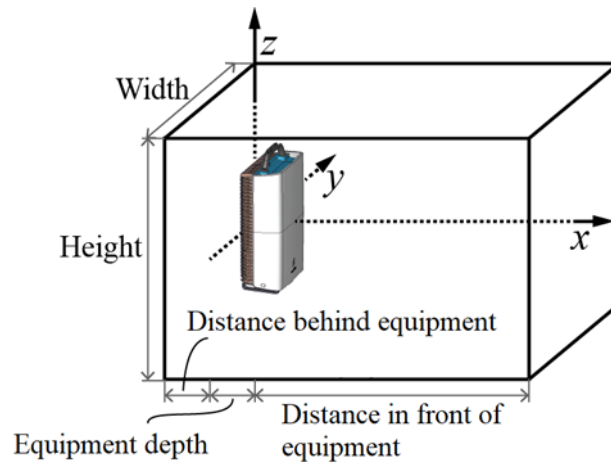

Figure 1 Box-shaped structure specifying the compliance boundary for the tested RBS product.

In Figure 2 and Figure 3, the compliance distance results for general public (blue line) and occupational (red line) exposure are given for the Single Radio and the Dual Radio versions, respectively. Also shown are the resulting compliance boundaries (black lines, solid for general public, dashed for occupational exposure). The resulting compliance boundary dimensions are given in Table 5 rounded upwards to the nearest decimeter.

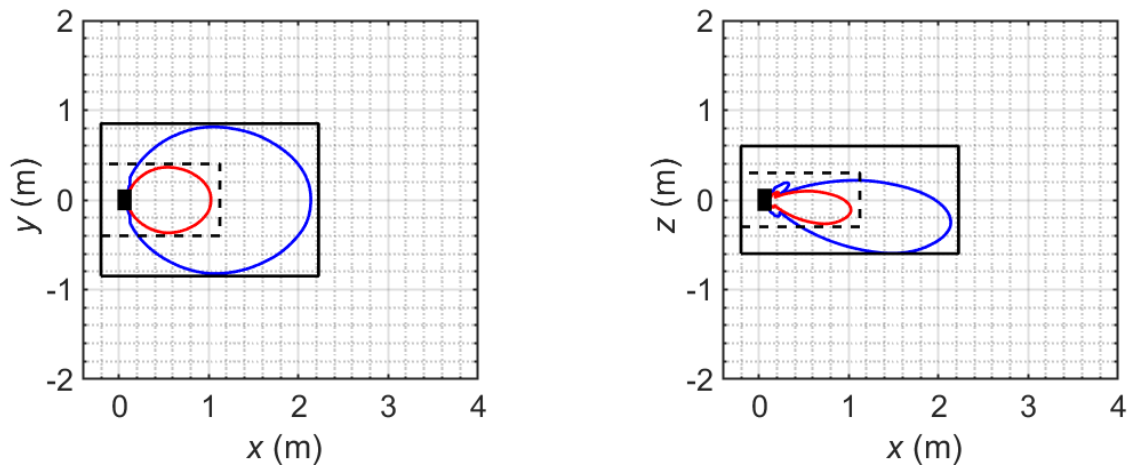

Figure 2 Compliance boundary for general public (black solid line) and occupational (black dashed line) exposure for Single Radio. The blue solid lines correspond to compliance distance results for general public exposure obtained using the spherical model. The solid red lines indicate the corresponding compliance distance results for occupational exposure. The EUT is shown from above (left) and from the side (right) with its back plane located at $x = 0$ m. Mode: B48 (LTE, NR). Total power delivered to the antenna: 17.0 W.

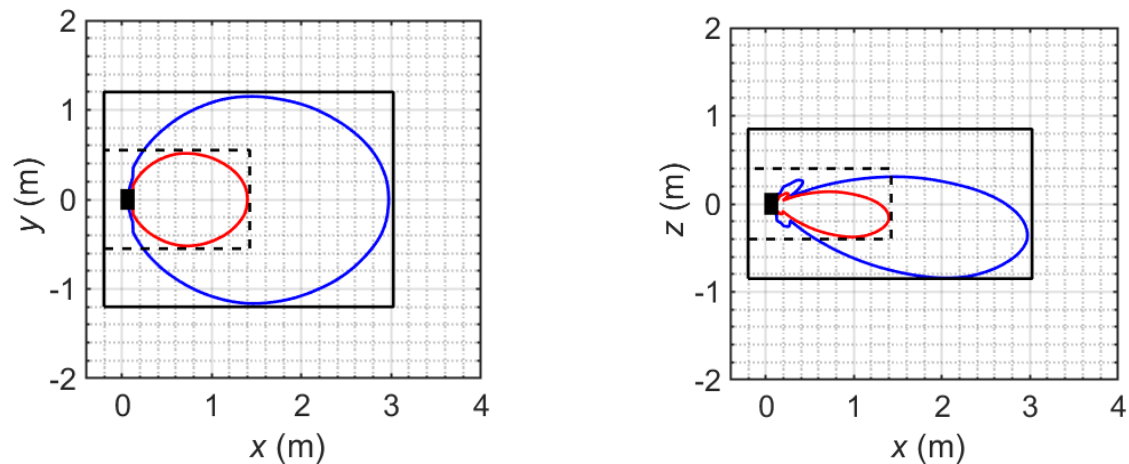

Figure 3 Compliance boundary for general public (black solid line) and occupational (black dashed line) exposure for Dual Radio. The blue solid lines correspond to compliance distance results for general public exposure obtained using the spherical model. The solid red lines indicate the corresponding compliance distance results for occupational exposure. The EUT is shown from above (left) and from the side (right) with its back plane located at $x = 0$ m. Mode: B48 (3600) (LTE, NR). Total power delivered to the antenna: 34.0 W.

Table 5 Dimensions of the box-shaped compliance boundary for general public (GP) and occupational (O) exposure for Radio 4408 B48 applicable in the markets employing the FCC exposure limits for maximum output power with output power tolerance and TDD downlink duty cycle included.

Mode and output power for Radio 4408 B48					Dimensions of the box-shaped compliance boundary (m)							
					Distance in front of EUT		Width		Height		Distance behind EUT	
Band	Standard	Single/Dual Radio version	Nominal output power from the radio	TDD DL duty cycle	GP	O	GP	O	GP	O	GP	O
B48	LTE, NR	Single	4 x 5 W	75%	2.1	0.9	1.7	0.8	1.2	0.7	0.2	0.2
B48	LTE, NR	Dual	4 x 5 W + 4 x 5 W	75%	2.9	1.3	2.4	1.1	2.0	1.1	0.2	0.2

For the power levels specified in the table with tolerances added, and the upward rounding of compliance boundary dimensions to the nearest decimeter, the specified results are conservative.

6 Uncertainty

For the input parameters defined in the test report, the calculated compliance boundary dimensions determined according to the approach described in Section 4 results in an exposure assessment which is conservative. The compliance boundary dimensions were determined by comparing the evaluated RF exposure directly with the limits.

7 Conclusion

The Ericsson Radio 4408 B48 has been tested using methods and procedures specified in FCC OET Bulletin 65 [3] and IEC 62232:2017 [4]. The results in Section 5 show the compliance boundary dimensions for the considered configurations of the product. Outside of these compliance boundaries, the RF exposure is below the limits specified in [1].

8 References

- [1] FCC, Code of Federal Regulations CFR title 47, part 1.1310 "Radiofrequency radiation exposure limits", Federal Communications Commission (FCC), April 2020.
- [2] Ericsson, GFTE-16:001718 Uen, "Ericsson RF exposure calculation procedure for base stations".
- [3] FCC, "Evaluating compliance with FCC guidelines for human exposure to radiofrequency electromagnetic fields. OET Bulletin 65. Edition 97-01." Federal Communications Commission (FCC), Office of Engineering and Technology, August 1997.
- [4] IEC 62232:2017, Determination of RF field strength, power density and SAR in the vicinity of radiocommunication base stations for the purpose of evaluating human exposure, June 2017.
- [5] Ericsson, LME-12:001904 Uen, "Exposure to radio frequency electromagnetic fields".

9 Revision history

Rev.	Date	Description
A	2019-08-21	First revision.
B	2021-12-06	NR configuration added. TDD DL duty cycle changed from 74% to 75%.

Appendix A. Information to be included in the CPI

Table A.1 below lists the compliance boundaries (exclusion zones), outside of which the RF EMF exposure from Radio 4408 is below the limits applicable in:

- USA (47 CFR 1.1310)

Table A.1 Dimensions of the box-shaped compliance boundary for general public (GP) and occupational (O) exposure for Radio 4408 applicable in the markets employing the FCC exposure limits.

Mode and output power						Dimensions of the box-shaped compliance boundary ⁽¹⁾ (m)							
						Distance in front of radio		Width		Height		Distance behind radio	
Product	Standard	Single/Dual Radio version	Nominal output power from the radio	IEC 62232 Installation class	TDD DL duty cycle	GP	O	GP	O	GP	O	GP	O
Radio 4408 B48	LTE, NR	Single	4 × 5 W	E+	75 %	2.1	0.9	1.7	0.8	1.2	0.7	0.2	0.2
Radio 4408 B48	LTE, NR	Dual	4 × 5 W + 4 × 5 W	E+	75 %	2.9	1.3	2.4	1.1	2.0	1.1	0.2	0.2

(1) The compliance boundaries are determined for maximum output power with power tolerance and TDD downlink duty cycle included.

Appendix B. Guidelines on how to install the product

The Radio 4408 B48 product (KRC 161 746/1) shall be installed to make sure that the general public does not have access to the applicable RF EMF compliance boundary. The compliance boundary dimensions were determined for the product transmitting in free space.

Appendix C. Guidelines for workers during installation, maintenance, and repair of the product

If work needs to be performed within the compliance boundary applicable for workers, the radio equipment shall be powered off, or the power be reduced to a level ensuring that the RF EMF exposure is below the relevant exposure limit for workers.

If work is conducted on behalf of Ericsson, minimum EMF related requirements are provided in [5].

Appendix D. Photographs of Radio 4408 B48

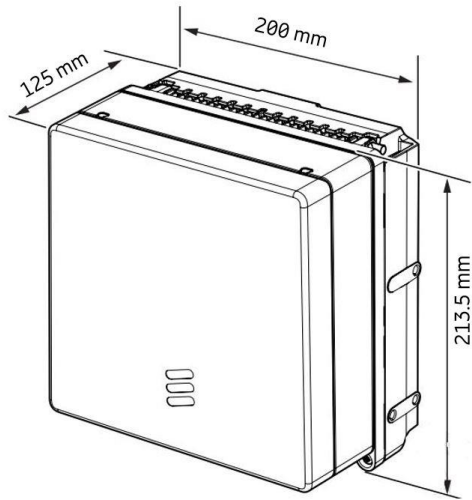

Figure D.1 Photograph of Single Radio version of Radio 4408 B48.

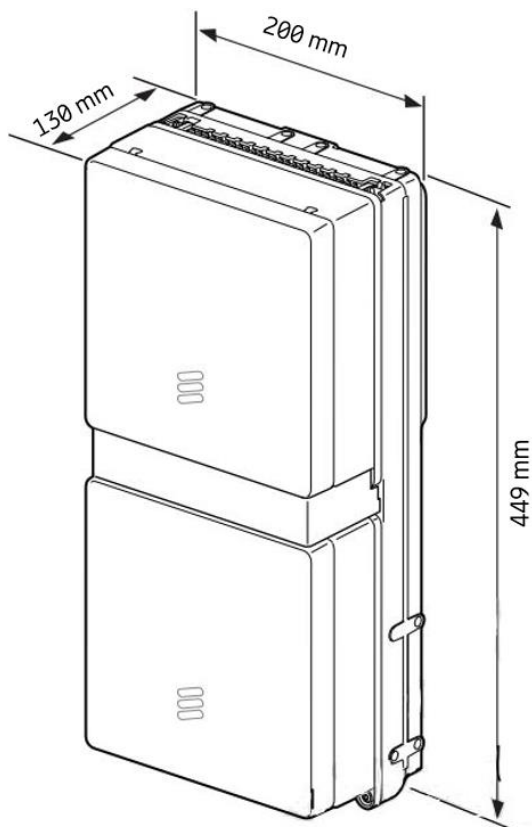

Figure D.2 Photograph of Dual Radio version of Radio 4408 B48.