



REPORT

Issued by an FCC listed Laboratory Reg. no. 93866
The test site complies with RSS-Gen, file no: IC 3482A



Contact person
Tomas Lennhager
Electronics
+46 10 516 54 09
Tomas.Lennhager@sp.se

Date
2014-12-02

Reference
4P06571-F27

Page
1 (2)

Ericsson AB
Mats Falk
PDU HW
Lindholmospiren 11
417 56 Göteborg

Radio measurements on RRUS 32 B30 radio equipment with FCC ID: TA8AKRC161423-1 and IC: 287AB-AS1614231 (8 appendices)

Test object

Product name: RRUS 32 B30
Product number: KRC 161 423/1, see appendix 1 for details.

Summary

See appendix 1 for general information and appendix 8 for external photos.

Standard	Compliant	Appendix
FCC CFR 47 / IC RSS-195 ISSUE 2		
2.1046 / RSS-195 5.5 RF power output conducted	Yes	2
2.1049 / RSS-Gen 6.6. Occupied bandwidth	Yes	3
2.1051 / RSS-195 5.6 Band edge	Yes	4
2.1051 / RSS-195 5.6 Spurious emission at antenna terminals	Yes	5
2.1053 / RSS-195 5.6 Field strength of spurious radiation	Yes	6
2.1055 / RSS-195 5.4 Frequency stability	Yes	7

Note: Above RSS-195 items are given as cross-reference only. Measurements were performed according to ANSI procedures referenced by FCC and covered by SP's accreditation.

SP Technical Research Institute of Sweden Electronics - EMC

Performed by

Examined by

Tomas Lennhager

Anders Nordlöf

SP Technical Research Institute of Sweden

Postal address
SP
Box 857
SE-501 15 BORÅS
Sweden

Office location
Västeråsen
Brinellgatan 4
SE-504 62 BORÅS

Phone / Fax / E-mail
+46 10 516 50 00
+46 33 13 55 02
info@sp.se

Laboratories are accredited by the Swedish Board for Accreditation and Conformity Assessment (SWEDAC) under the terms of Swedish legislation. This report may not be reproduced other than in full, except with the prior written approval of the issuing laboratory.

Table of contents

Description of the test object	Appendix 1
Operation mode during measurements	Appendix 1
Test setups	Appendix 1
Purpose of test	Appendix 1
RF power output conducted	Appendix 2
Occupied bandwidth	Appendix 3
Band edge	Appendix 4
Spurious emission at antenna terminals	Appendix 5
Field strength of spurious radiation	Appendix 6
Frequency stability	Appendix 7
External photos	Appendix 8

Appendix 1

Description of the test object

Equipment:	Product name: RRUS 32 B30 Product numbers: KRC 161 423/1 FCC ID TA8AKRC161423-1 IC 287AB-AS1614231
Tested configuration:	LTE single RAT
Frequency bands:	TX: 2350 – 2360 MHz RX: 2305 – 2315 MHz
Antenna ports:	4 TX/RX ports
RF configurations:	Single carrier, multi carrier, MIMO 4x4
Nominal output power per antenna port:	Single carrier: 1x 44 dBm (1 x 25W) Multi carrier: 2 x 41 dBm (2 x 12.5W)
RF power Tolerance:	±0.6 dB
Frequency stability tolerance:	±0.05 PPM
Antenna:	No dedicated antenna, handled during licensing
Modulations:	QPSK, 16QAM and 64QAM
Channel bandwidth:	5 MHz, 10 MHz
Nominal power voltage:	-48VDC

Appendix 1

Operation mode during measurements

Measurements were performed with the test object transmitting test models as defined in 3GPP TS 36.141. Test model E-TM1.1 represent QPSK modulation, test model E-TM3.2 represent 16QAM modulation and test model E-TM3.1 represent 64QAM modulation.

The settings below were deemed representative for all traffic scenarios when settings with different modulations, channel bandwidths, number of carriers and RF configurations has been tested to find the worst case setting. All measurements were performed with the test object configured for maximum transmit power. The settings below were used for all measurements if not otherwise noted.

MIMO mode, single carrier: E-TM1.1

MIMO mode, multi carrier: 2 carriers E-TM1.1

Conducted measurements

The test object was supplied with -48 VDC by an external power supply if not noted otherwise. Additional connections are documented in the setup drawings below. Complete measurements were made on RF A with additional measurements on RF B, C and D to verify that the ports are identical.

Radiated measurements

The test object was supplied with -48 VDC by an external power supply. Additional connections are documented in the setup drawings below.

Purpose of test

The purpose of the tests is to verify compliance to the performance characteristics specified in applicable items of FCC CFR 47 and IC RSS-195 and IC RSS-Gen.

References

Measurements were done according to relevant parts of the following standards:

ANSI 63.4-2009

ANSI/TIA/EIA-603-C-2004

3GPP TS 36.141, version 11.4.0

CFR 47 part 2, December 16th, 2013

CFR 47 part 27, December 16th, 2013

RSS-Gen Issue 4

RSS-195 Issue 2

Appendix 1

Uncertainties

Measurement and test instrument uncertainties are described in the quality assurance documentation "SP-QD 10885". The uncertainties are calculated with a coverage factor $k=2$ (95% level of confidence).

Compliance evaluation is based on a shared risk principle with respect to the measurement uncertainty.

Reservation

The test results in this report apply only to the particular test object as declared in the report.

Delivery of test object

The test object was delivered 2014-11-10.

Manufacturer's representative

Mihai Simon, Ericsson AB.

Test engineers

Tomas Isbring, Tomas Lennhager, Rolf Kühn, Maulo Rivera-Avalos and Rani Karnabi, SP

Test participants (partially)

Mihai Simon, Ericsson AB.

Appendix 1

Measurement equipment

	Calibration Due	SP number
Test site Tesla	2017-01	503 881
R&S ESU 26	2015-05	901 553
R&S ESU 40	2015-07	901 385
R&S ESI 26	2015-07	503 292
R&S FSQ 40	2015-07	504 143
R&S FSW 43	2015-07	902 073
R&S FSIQ 40	2015-07	503 738
Control computer with R&S software EMC32 version 8.52.0	-	503 899
High pass filter	2015-01	BX40074
High pass filter	2015-07	901 501
High pass filter	2015-07	901 502
High pass filter	2015-07	504 199
High pass filter	2015-07	901 373
High pass filter	2016-07	503 739
High pass filter	2015-07	503 740
RF attenuator	2016-07	503 248
RF attenuator	2016-06	503 249
RF attenuator	2015-08	504 159
RF attenuator	2015-07	900 233
RF attenuator	2015-06	901 384
RF attenuator	2014-11	901 508
Directional coupler	2015-10	901 496
EAB diplex bandreject filter 1/ULK904334/2, R1A, s/n: 3470005	2015-10	-
Chase Bilog Antenna CBL 6111A	2014-10	503 182
EMCO Horn Antenna 3115	2016-09	502 175
µComp Nordic, Low Noise Amplifier	2015-01	901 545
Flann STD Gain Horn Antenna 16240-25	-	503 939
Flann STD Gain Horn Antenna 18240-25	-	503 900
Flann STD Gain Horn Antenna 20240-20	-	503 674
Miteq, Low Noise Amplifier	2015-08	503 285
Schwarzbeck preamplifier BBV 9742	2015-01	504 085
Miteq 18-40 GHz, Low Noise Amplifier	2015-01	503 278
Temperature and humidity meter, Testo 635	2015-03	504 203
Temperature and humidity meter, Testo 625	2015-06	504 188
Temperature Chamber	-	503 360
Multimeter Fluke 87	2015-08	502 190

Appendix 1

Test frequencies during measurements

Single RAT TX test frequencies

EARFCN Downlink	Frequency [MHz]	Symbolic name	Comment
9795	2352.5	B	TX bottom frequency in 5 MHz BW configuration
9820	2355.0	M	TX middle frequency in 5 and 10MHz BW configuration
9845	2357.5	T	TX bottom frequency in 5 MHz BW configuration
9795	2352.2	M2	2 carrier TX band middle constellation
9845	2357.5		5 MHz BW configuration

All RX frequencies were configured 45 MHz below the corresponding TX frequency according the applicable duplex offset for the operating band.

Appendix 1

Test setup conducted measurements

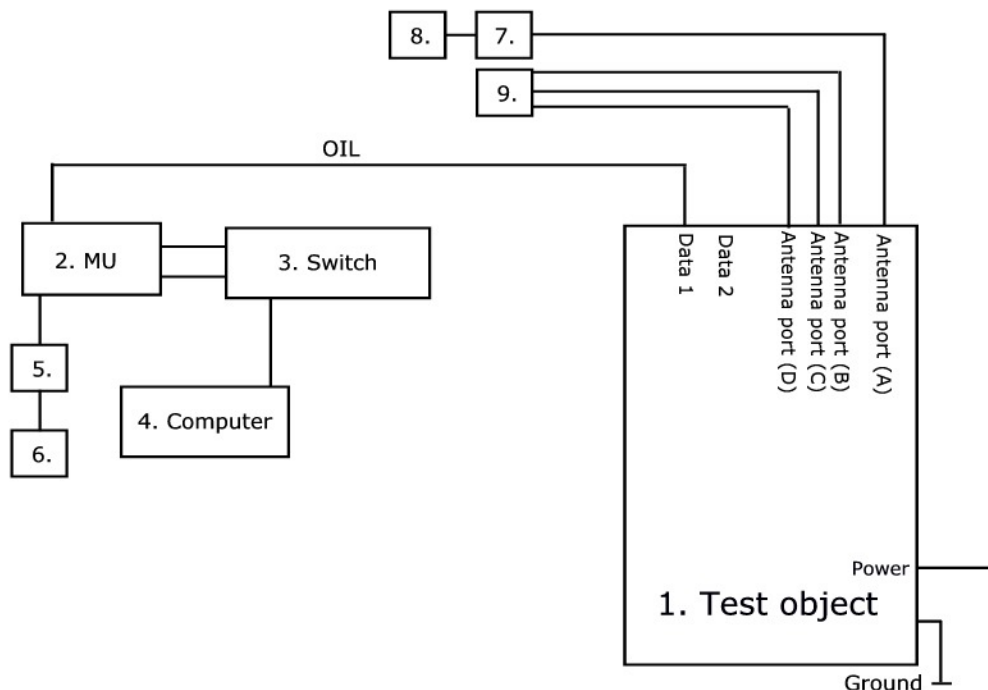

Test object:

1.	RRUS 32 B30, KRC 161 423/1, rev R1B, s/n: C828613168 software CXP 901 7316/5, rev R59DH with FCC ID: TA8AKRC161423-1 and IC 287AB-AS1614231
----	---

Functional test equipment:

2.	Main Unit DUS 41 01 KDU 137 624/1 R5A, s/n: D168382143, hosted in SUP 6601 1/BFL 901 009/4, rev. R1E, s/n. BR82691170
3.	Switch Netgear GSM 7212, BAMS-1000517298
4.	Computer Sun microsystems ultra 27, BAMS – 1000758439
5.	GPS 02 01, NCD 901 41/1, rev. R1D, s/n: TU8K474887
6.	GPS Active Antenna, KRE 101 2082/1
7.	SP Test Instrumentation according to measurement equipment list
8.	SP Test Instrumentation according to measurement equipment list
9.	Terminators, 50 ohm

Appendix 1

Test set-up radiated measurements

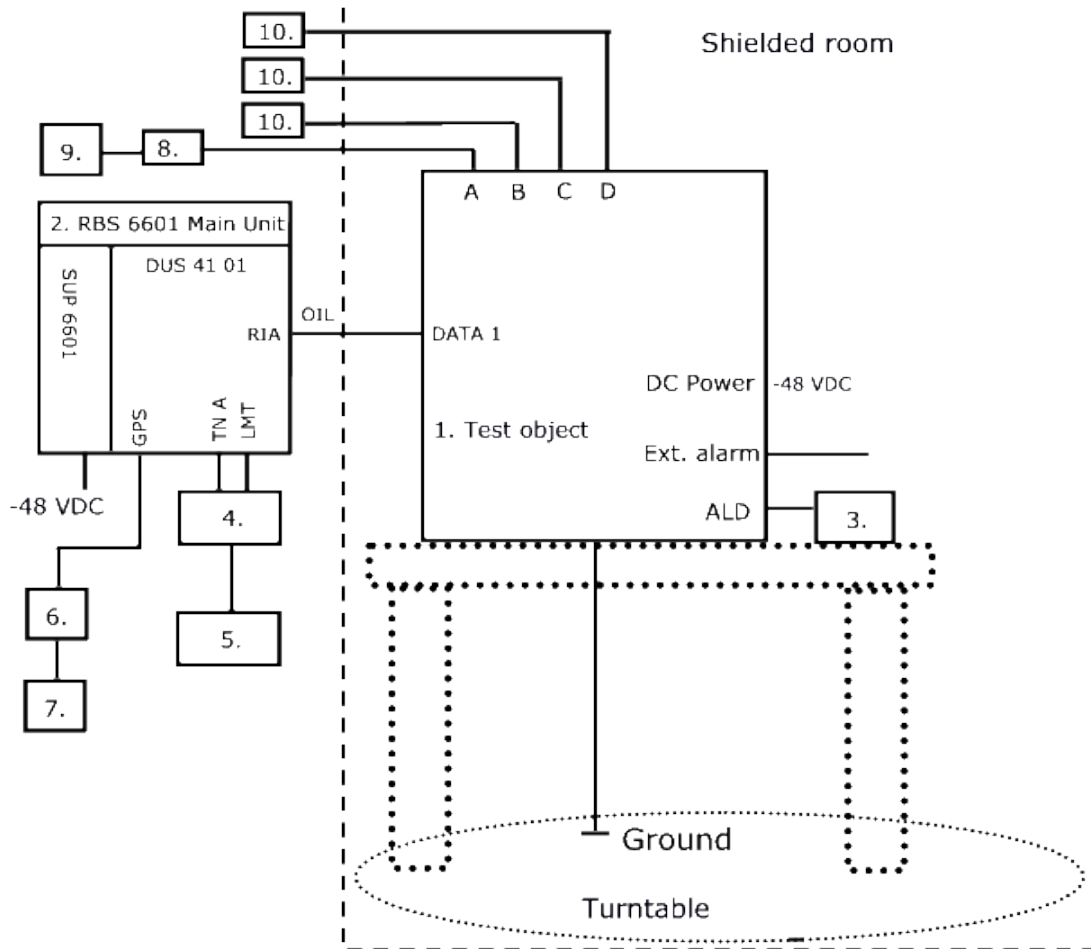

Test object:

1.	RRUS 32 B30, KRC 161 423/1, rev. R1B, s/n: C828613170 working software CXP 901 7316/5, rev. R59DH
----	--

Functional test equipment:

2.	RBS 6601 Main Unit: SUP 6601, 1/ BFL 901 009/4, rev: R1E, s/n: BR88237597 DUS 41 01, KDU 137 624/1, rev: R5A/A, s/n: D16D326056
3.	RET, KRY 121 67/2, rev: R1G, BAMS – 1000601140
4.	Switch Neatgear GSM 7212, BAMS – 1000517299
5.	Desktop Ultra 27 Sun microsystems, BAMS – 1000758436
6.	GPS 02 01, NCD 901 41/1, rev. R1D, s/n: TU8KH75515
7.	GPS Active Antenna, KRE 101 2082/1
8.	Attenuator
9.	R&S ESIB 26, SP number: 503 292, for supervision purpose only
10.	Attenuator/ Terminator

Appendix 1

Interfaces:	Type of port:
Power: -48 VDC	DC Power
A, 7/16 connector, combined TX/RX	Antenna
B, 7/16 connector, combined TX/RX	Antenna
C, 7/16 connector, combined TX/RX	Antenna
D, 7/16 connector, combined TX/RX	Antenna
1, optical interface	Signal
2, optical interface, not used in this configuration	Signal
ALD	Signal
Ext. alarm	Signal
Ground wire	Ground

RBS software:

Product number	Revision
CXP 102 051/22	R36AJ

Appendix 2

RF power output measurements according to CFR 47 §27.50 / IC RSS-195 5.5, conducted

Date	Temperature	Humidity
2014-11-12	24 °C ± 3 °C	27 % ± 5 %
2014-11-13	24 °C ± 3 °C	32 % ± 5 %

Test set-up and procedure

The test object was connected to a signal analyzer measuring peak and RMS output power in CDF mode. A resolution bandwidth of 80 MHz was used acc. to KDB971168, chapter 5.2.3.

For the 1 MHz power averaging measurement method acc. to KDB971168, chapter 5.4.1

Measurement equipment	SP number
R&S FSW	902 073
RF attenuator	902 282
Testo 635, temperature and humidity meter	504 203

Measurement uncertainty: 1.1 dB

Results

MIMO mode

Rated output power level at RF connector 4x 44 dBm. Total nominal RF power 50 dBm.

Tested configuration	[RMS dBm/ PAR dB]				
	Port RF A	Port RF B	Port RF C	Port RF D	Total power ¹⁾
5 MHz, B	44.00/ 7.28	44.02/ 7.26	43.79/ 7.28	43.87/ 7.28	49.94
5 MHz, M	44.01/ 7.26	43.99/ 7.26	43.77/ 7.26	43.95/ 7.26	49.95
5 MHz, T	44.01/ 7.28	43.95/ 7.32	43.74/ 7.32	43.91/ 7.30	49.92
10 MHz, M	43.96/ 7.30	43.90/ 6.32	43.79/ 7.30	43.91/ 7.30	50.19
5 MHz, M2	43.60/ 7.34	43.62/ 7.38	43.66/ 7.36	43.96/ 7.34	49.73

¹⁾: summed output power according to FCC KDB662911 Multiple transmitter output v01r02

Appendix 2

Power / MHz

Rated output power level at RF connector 4x 44 dBm. Total nominal RF power 50 dBm.

Tested configuration	[RMS dBm/ PAR dB]				
	Port RF A	Port RF B	Port RF C	Port RF D	Total power ¹⁾
BW and frequency					
5 MHz, B	23.29	23.32	23.07	23.20	29.32
5 MHz, M	23.30	23.27	23.07	23.24	29.30
5 MHz, T	23.29	23.25	22.97	23.21	29.29
10 MHz, M	20.16	20.03	20.18	20.25	26.25

¹⁾: summed output power according to FCC KDB662911 Multiple transmitter output v01r02

Remark

ERP/EIRP compliance is addressed at the time of licensing, as required by the responsible FCC/IC Bureau(s). Licensee's are required to take into account maximum antenna gain used in combination with above power settings to prevent the radiated output power to exceed the limits.

Limits

CFR 47 §27.50 (a): The average equivalent isotropically radiated power (EIRP) must not exceed 2,000 watts within any 5 megahertz of authorized bandwidth and must not exceed 400 watts within any 1 megahertz of authorized bandwidth.

The peak-to-average power ratio (PAPR) of the transmitter output power must not exceed 13 dB.

RSS-195 5.5 & SRSP-516 Issue 1:

The equivalent isotropically radiated power (e.i.r.p.) of the base and fixed stations shall not exceed 400 watts within any 1 MHz band; and shall not exceed 2000 W within any 5 MHz of bandwidth.

The PAPR of the transmitter output power of base and fixed station equipment shall not exceed 13 dB for more than 0.1% of the time.

Complies?	Yes
-----------	-----

Appendix 3

Occupied bandwidth measurements according to CFR 47 2.1049 / RSS-Gen 6.6.

Date	Temperature	Humidity
2014-11-26	22°C ± 3°C	26 % ± 5 %
2014-12-02	23°C ± 3°C	19 % ± 5 %

Test set-up and procedure

The measurements were made per definition in FCC: KDB: 971168 D01 Power Meas Licens, v02r02 and IC: RRS-Gen - Issue 4 (2014-11), kap. 6.6. The output was connected to a signal analyzer with the Peak detector activated and max hold. The signal analyzer was connected to an external 10 MHz reference standard during the measurements.

Measurement equipment	SP number
R&S FSW	902 073
RF attenuator	902 282
Testo 635, temperature and humidity meter	504 203

Measurement uncertainty: 3.7 dB

Results

MIMO mode, single carrier

Diagram	BW configuration	Tested frequency	Tested Port	Occupied BW (99%) [MHz]
1	5 MHz	B	RF A	4.47
2	5 MHz	T	RF A	4.47
3	5 MHz	M	RF A	4.47
4	10 MHz	M	RF A	8.92
5	5 MHz	M	RF B	4.47
6	5 MHz	M	RF C	4.47
7	5 MHz	M	RF D	4.47

Appendix 3

Diagram 1:

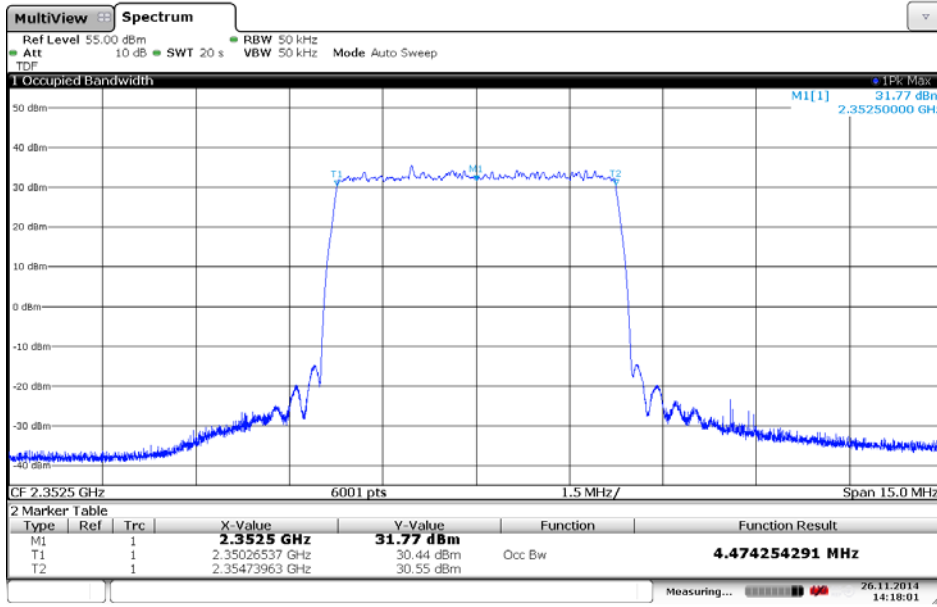

Date: 26 NOV 2014 14:18:00

Diagram 2:

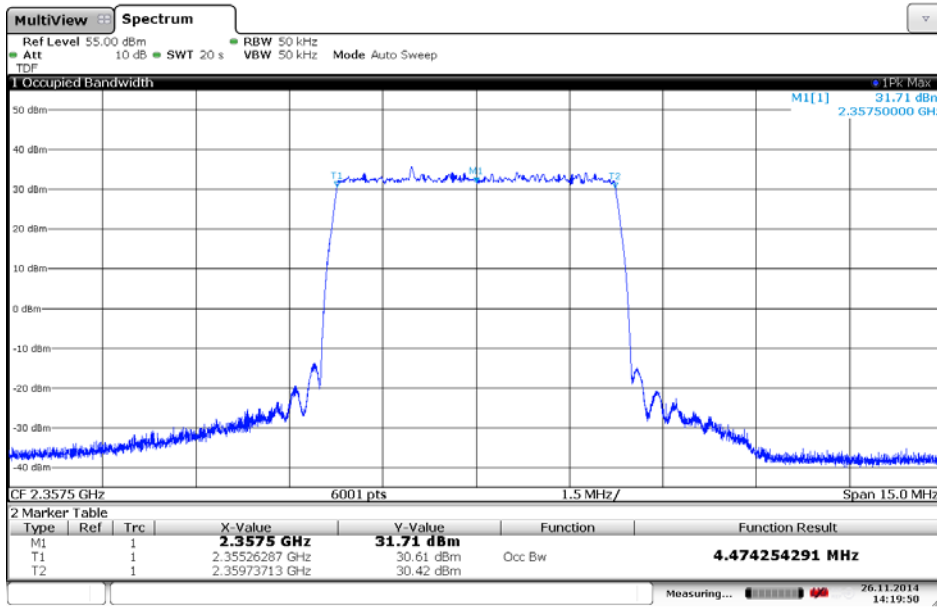

Date: 26 NOV 2014 14:19:50

Appendix 3

Diagram 3:

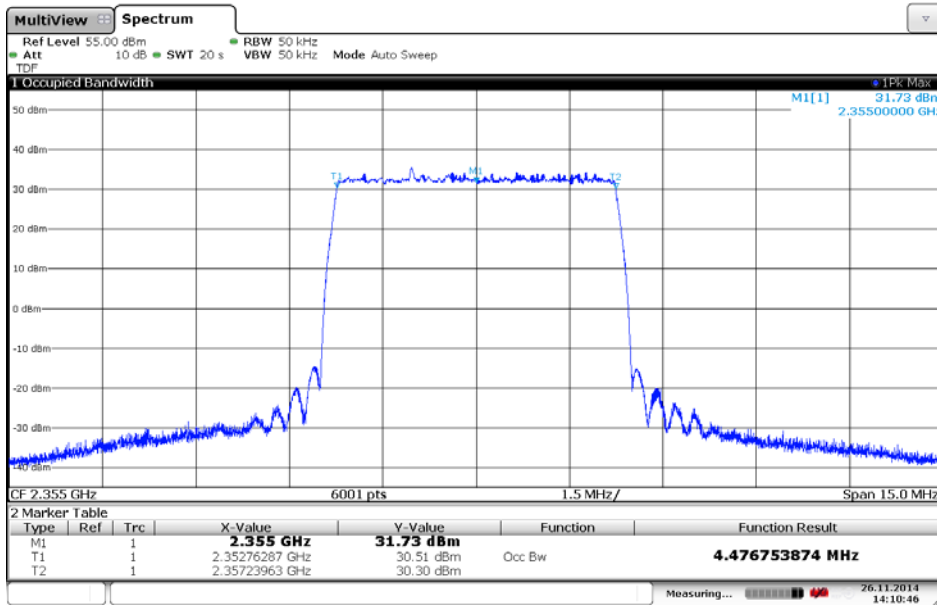
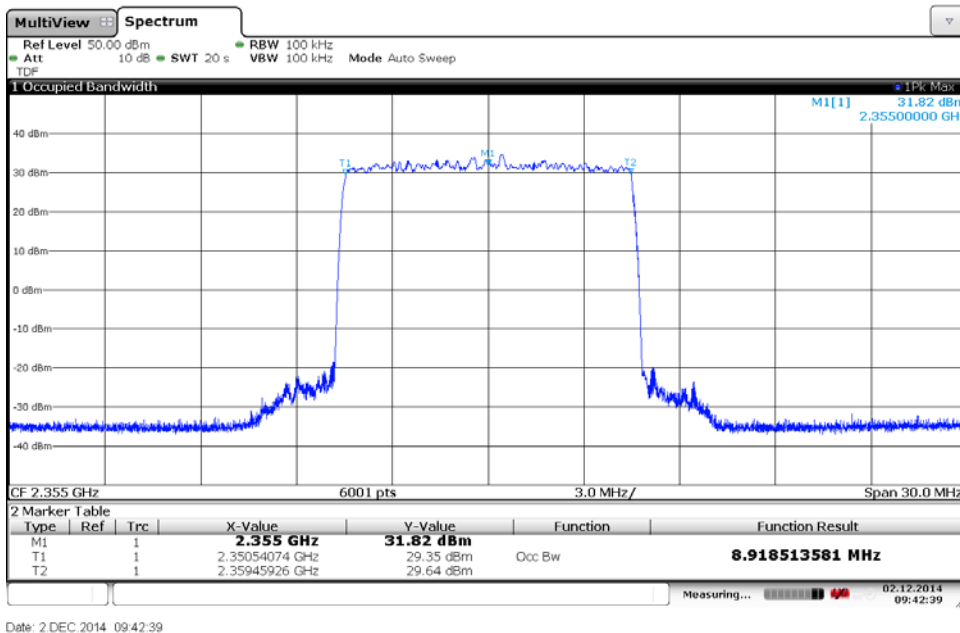
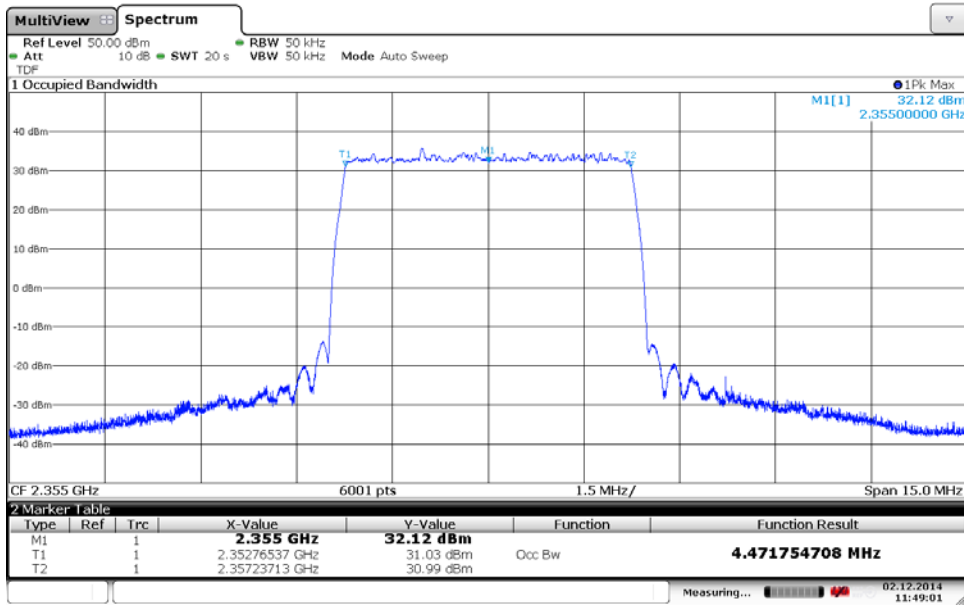

Diagram 4:



Appendix 3

Diagram 5:



Date: 2 DEC 2014 11:49:01

Diagram 6:

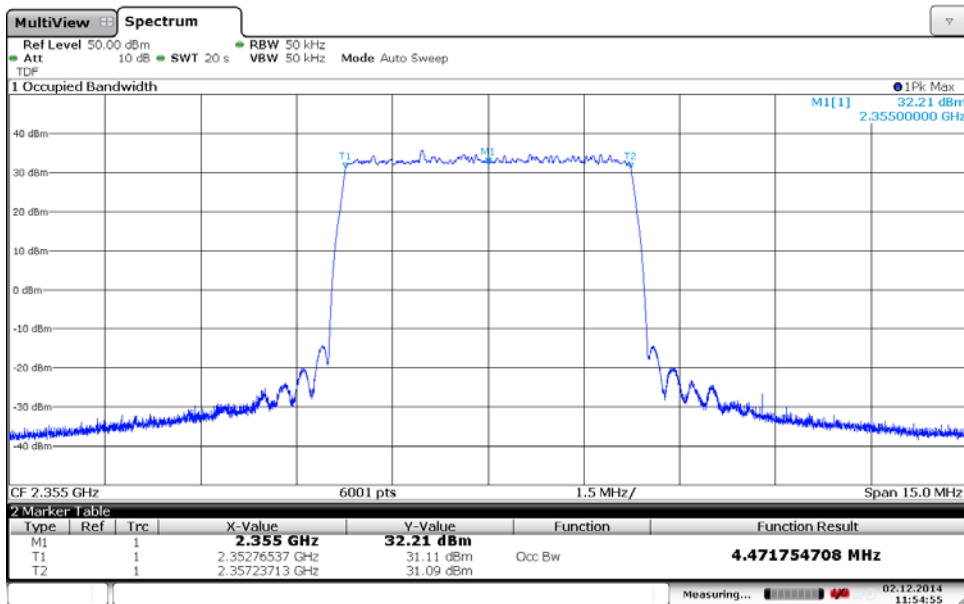

Date: 2 DEC 2014 11:54:56

Appendix 3

Diagram 7:

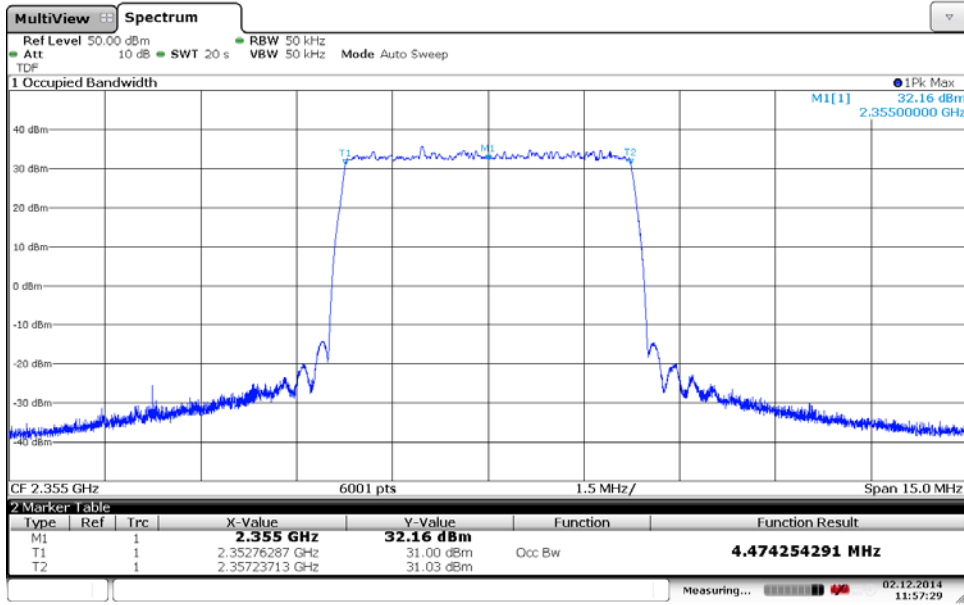

Appendix 4

Band edge measurements according to CFR 47 §27.53(a) / IC RSS-195 6.6.1

Date	Temperature	Humidity
2013-11-13	24°C ± 3°C	32 % ± 5 %
2013-11-14	23°C ± 3°C	28 % ± 5 %

Test set-up and procedure

The measurements were made per definition in §27.53(a) and IC RSS-195 6.6.1. The test object was connected to a spectrum analyzer with the RMS detector activated. The spectrum analyzer was connected to an external 10 MHz reference standard during the measurements.

The transmitter unwanted emissions shall be measured with a resolution bandwidth of 1 MHz. A smaller resolution bandwidth is permitted provided that the measured power is integrated over the full required measurement bandwidth of 1 MHz. Where a smaller RBW was used as compared to the rules, the limit in the plot is adjusted by $10 \log (RBW_{used}/RBW_{specified})$ [dB].

However, in the 1 MHz bands immediately adjacent to the edges of the frequency range(s) in which the equipment is allowed to operate, a resolution bandwidth of as close as possible to, without being less than 1% of the emission bandwidth, shall be employed provided that the measured power is integrated over the full required measurement bandwidth of 1 MHz.

Before comparing the results to the limit, 6 dB [10 log (4)] should be added according to method 2 “measure and add 10 log(N_{ANT})” of FCC KDB662911 D01 Multiple Transmitter Output v01r02

Measurement equipment	SP number
R&S FSW	902 073
RF attenuator	902 282
Testo 635, temperature and humidity meter	504 203
EAB duplex bandreject filter	1/ULK904334/2, R1A, s/n: 13470005

Measurement uncertainty: 3.7 dB

Results

MIMO mode

Diagram	BW configuration	Tested frequency	Tested Port
1 a-c	5 MHz	B	RF A
2 a-c	10 MHz	M	RF A
3 a-d	10 MHz	M	RF A
4 a-d	5 MHz	T	RF A

Appendix 4

Limits

CFR 47 §27.53(a)

Outside a licensee's frequency band(s) of operation the power of any emission shall be attenuated below the transmitter power (P) by the amount indicated in table below, measured with 1 MHz RBW.

Frequency (MHz)	Attenuation (dB)
< 2285	$75 + 10 \log_{10}(p)$
2285 - 2287.5	$72 + 10 \log_{10}(p)$
2287.5 - 2300	$70 + 10 \log_{10}(p)$
2300 - 2305	$43 + 10 \log_{10}(p)$
2305 - 2320	$43 + 10 \log_{10}(p)$
2320 - 2345	$75 + 10 \log_{10}(p)$
2345 - 2360	$43 + 10 \log_{10}(p)$
2360 - 2362.5	$43 + 10 \log_{10}(p)$
2362.5 - 2365	$55 + 10 \log_{10}(p)$
2365 - 2367.5	$70 + 10 \log_{10}(p)$
2367.5 - 2370	$72 + 10 \log_{10}(p)$
> 2370	$75 + 10 \log_{10}(p)$

RSS-195 5.6

Outside a licensee's frequency band(s) of operation the power of any emission shall be attenuated below the transmitter power (P) by the amount indicated in table below, measured with 1 MHz RBW:

Frequency (MHz)	Attenuation (dB)
<2200	$43 + 10 \log_{10}(p)$
2200 - 2285	$75 + 10 \log_{10}(p)$
2285 - 2287.5	$72 + 10 \log_{10}(p)$
2287.5 - 2300	$70 + 10 \log_{10}(p)$
2300 - 2305	$43 + 10 \log_{10}(p)$
2305 - 2320	$43 + 10 \log_{10}(p)$
2320 - 2345	$75 + 10 \log_{10}(p)$
2345 - 2360	$43 + 10 \log_{10}(p)$
2360 - 2362.5	$43 + 10 \log_{10}(p)$
2362.5 - 2365	$55 + 10 \log_{10}(p)$
2365 - 2367.5	$70 + 10 \log_{10}(p)$
2367.5 - 2370	$72 + 10 \log_{10}(p)$
2370 - 2395	$75 + 10 \log_{10}(p)$
>2395	$43 + 10 \log_{10}(p)$

Complies?	Yes
-----------	-----



Appendix 4

Appendix 4

Diagram 1a:

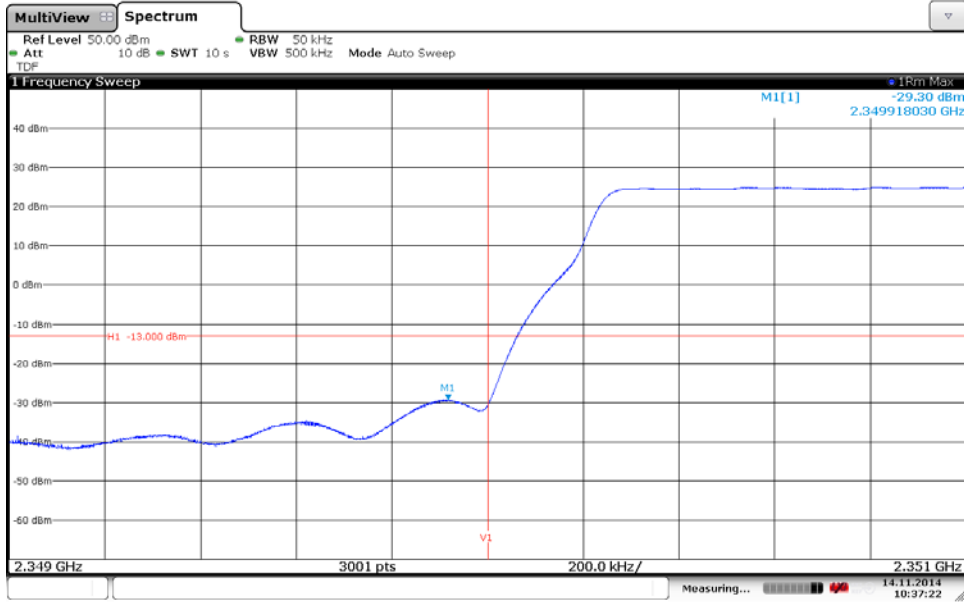

Date: 14 NOV. 2014 10:37:22

Diagram 1b:

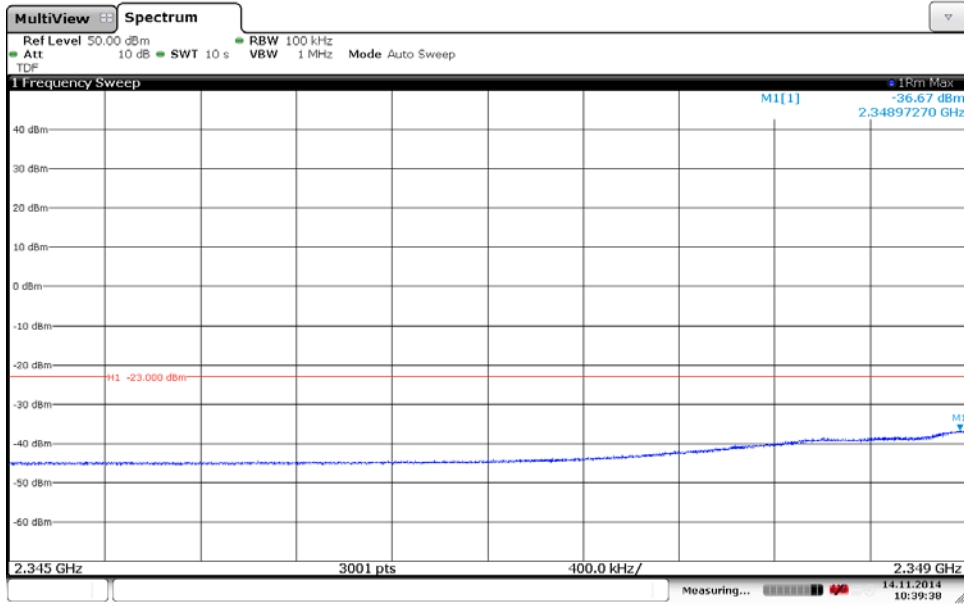

Date: 14 NOV. 2014 10:39:38

Appendix 4

Diagram 1c:

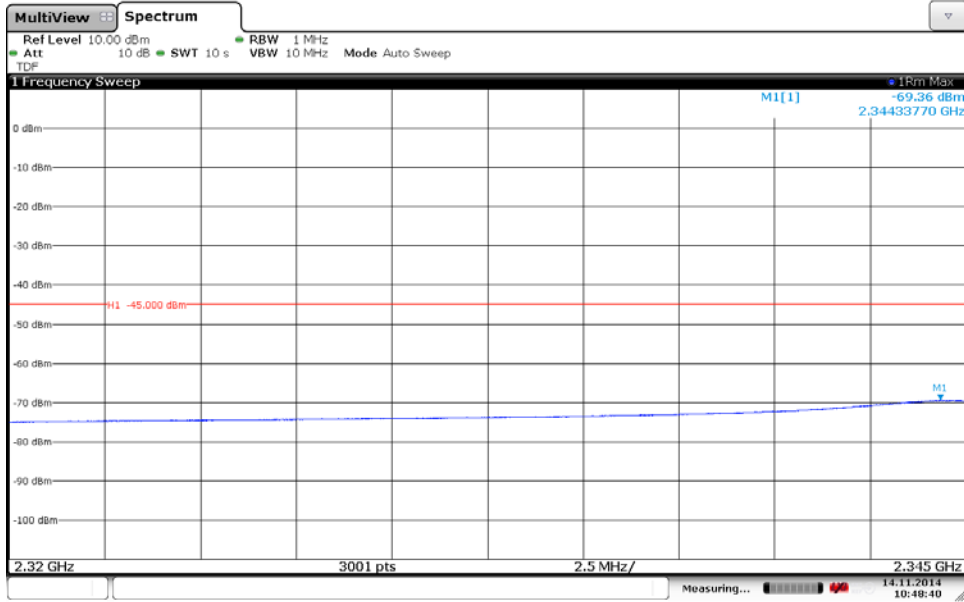

Appendix 4

Diagram 2a:

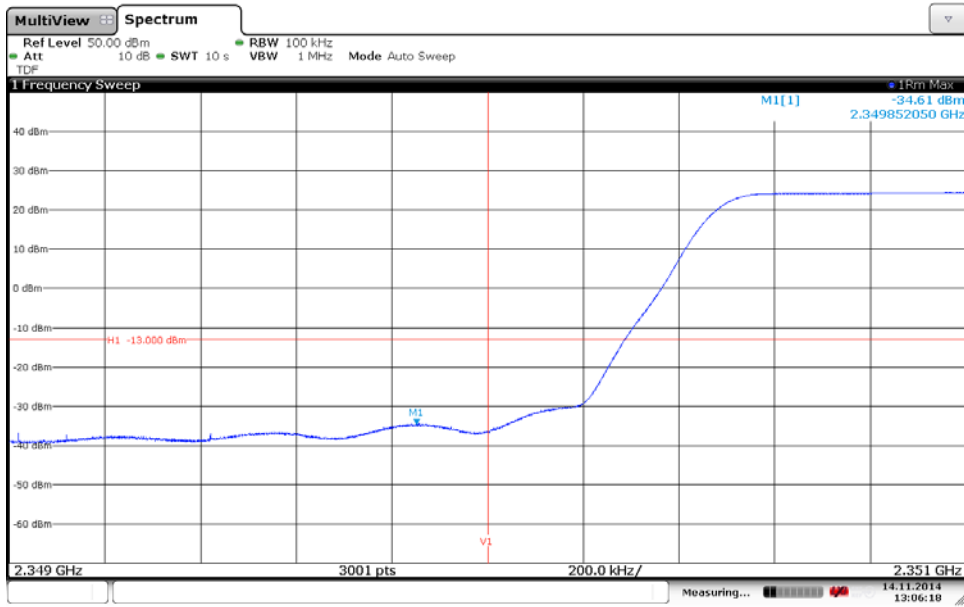
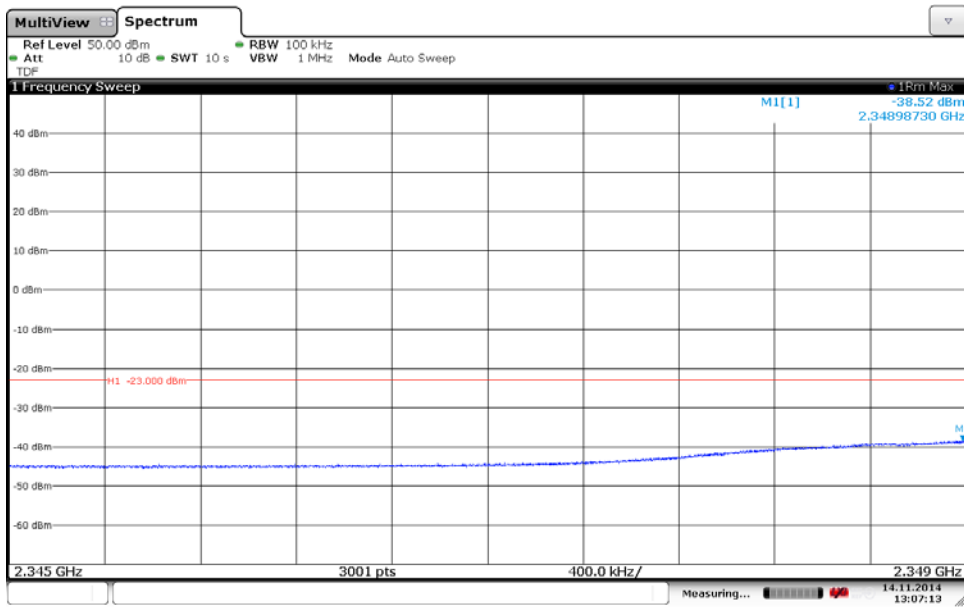
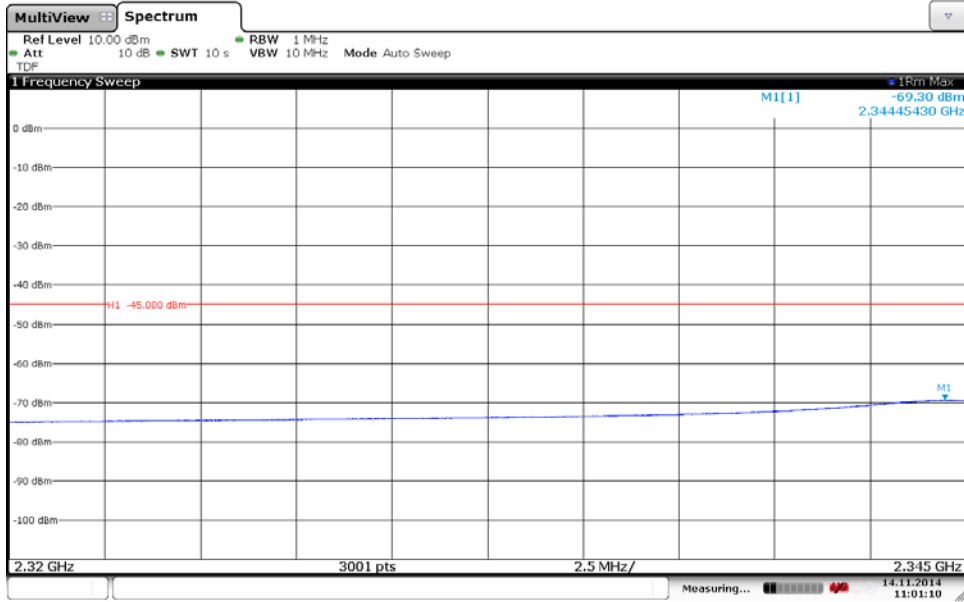

Diagram 2b:



Appendix 4

Diagram 2c:



Appendix 4

Diagram 3a:

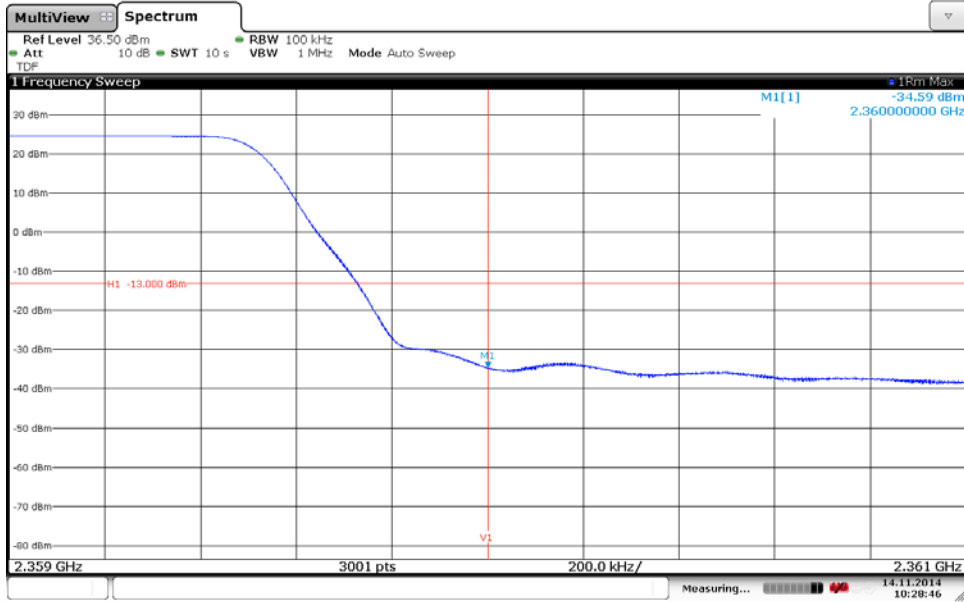
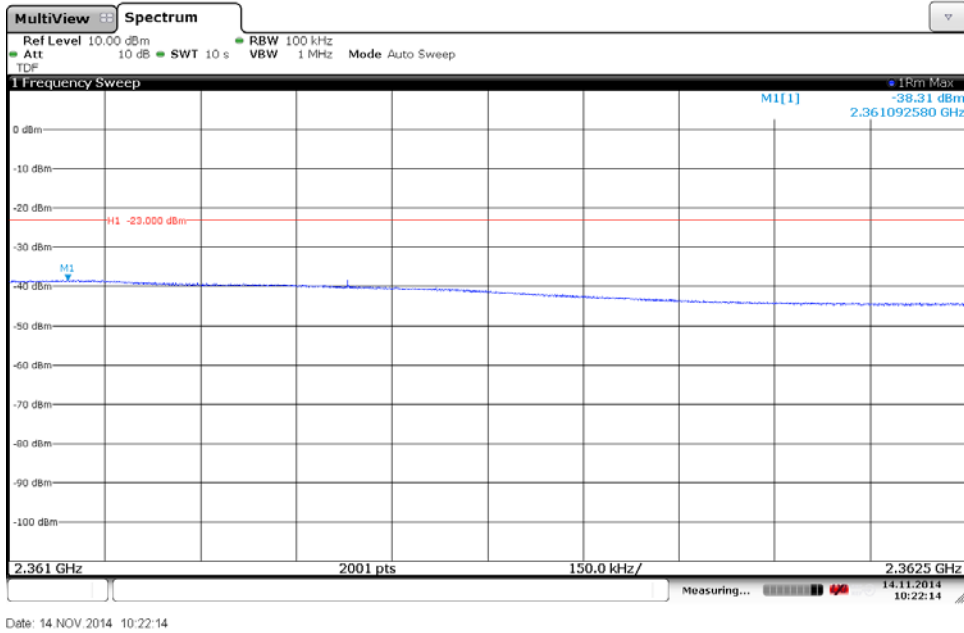

Diagram 3b:



Appendix 4

Diagram 3c:

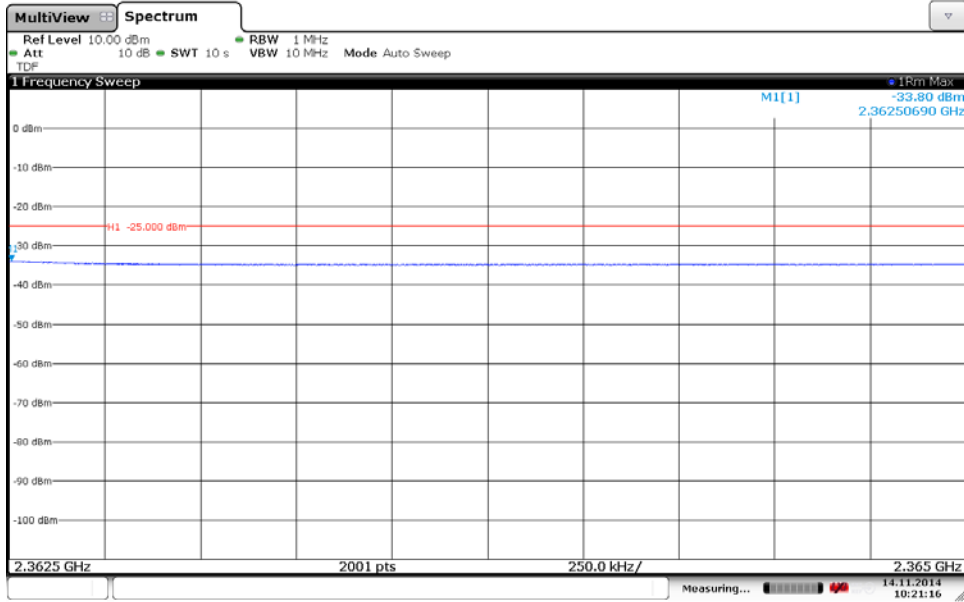
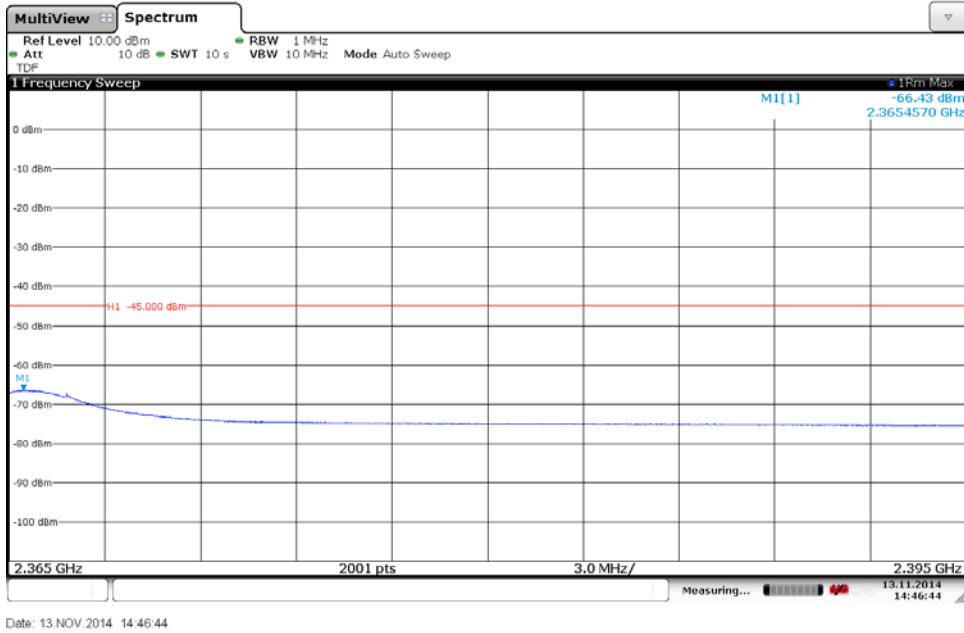

Diagram 3d:



Appendix 4

Diagram 4a:

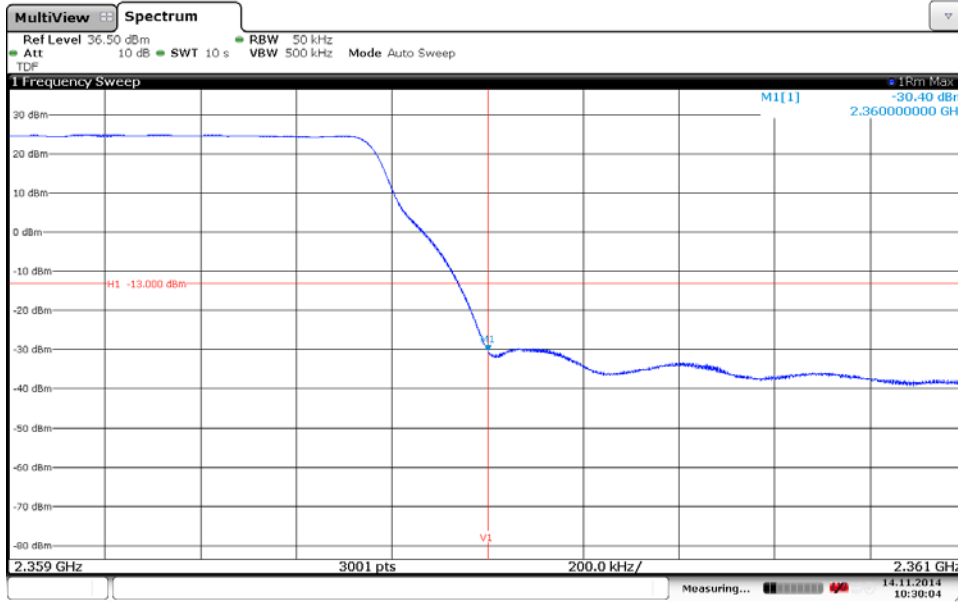
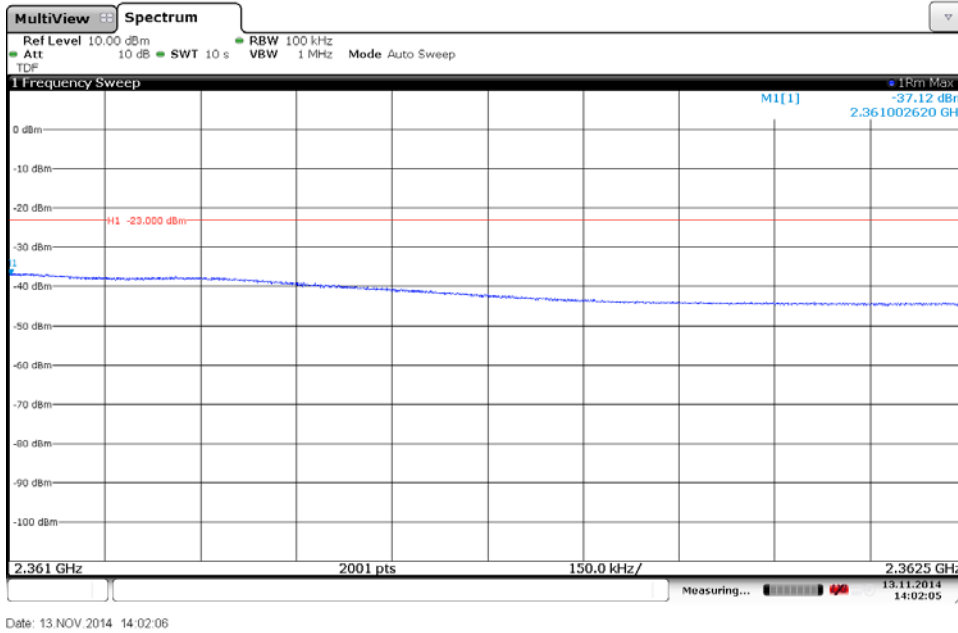

Diagram 4b:



Appendix 4

Diagram 4c:

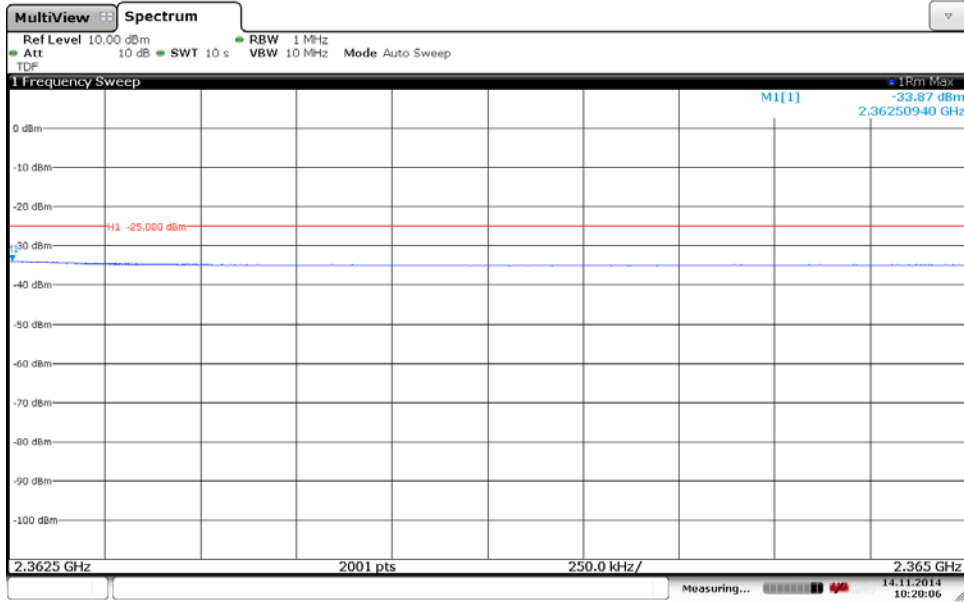
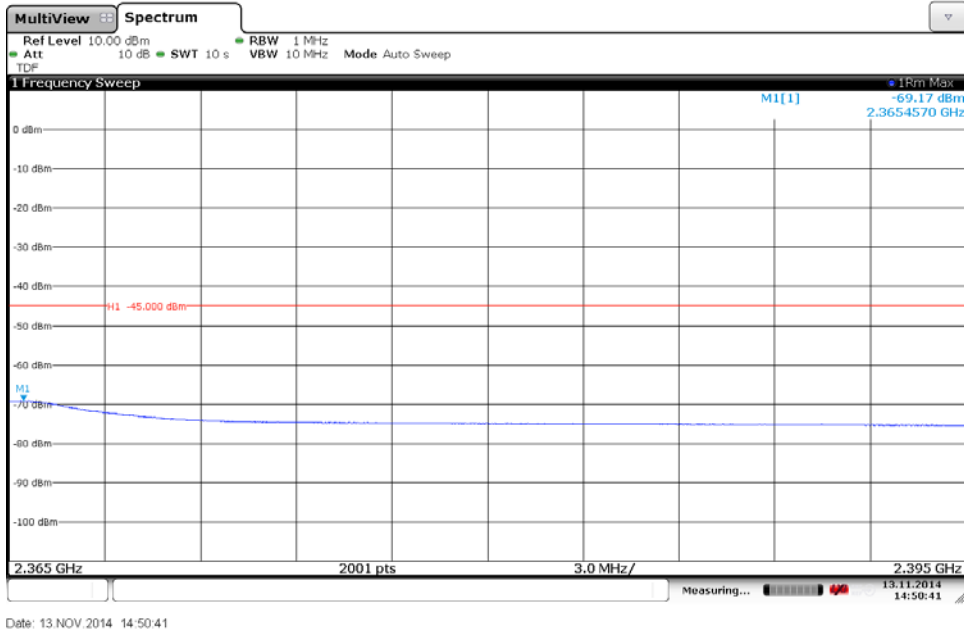

Diagram 4d:



Appendix 5

Conducted spurious emission measurements according to CFR 47 §27.53(a) / IC RSS-195 6.6.1

Date	Temperature	Humidity
2014-11-17	23 °C ± 3 °C	31 % ± 5 %
2014-11-18	23 °C ± 3 °C	33 % ± 5 %

Test set-up and procedure

The measurements were made per definition in §27.53(a) and IC RSS 195 6.6.1. The output was connected to a spectrum analyzer with a RBW setting of 1 MHz and RMS detector activated. The spectrum analyzer was connected to an external 10 MHz reference standard during the measurements.

Before comparing the results to the limit, 6 dB [10 log (4)] should be added according to method 2 “measure and add 10 log(N_{ANT})” of FCC KDB662911 D01 Multiple Transmitter Output v02

Measurement equipment	SP number
R&S FSW	902 073
RF attenuator	902 282
RF attenuator	900 691
RF attenuator	900 233
Directional coupler	901 496
EAB diplex bandreject filter	1/ULK904334/2, R1A, s/n: 13470005
HP filter	901 501
Testo 635, temperature and humidity meter	504 203

Measurement uncertainty: 3.7 dB

Appendix 5

Results

MIMO mode, Single and multi carrier

Diagram	BW configuration / [MHz]	Tested frequency	Tested Port
1 a+b+c+d	5 MHz	B	RF A
2 a+b+c+d	5 MHz	M	RF A
3 a+b+c+d	10 MHz	M	RF A
4 a+b+c+d	5 MHz	T	RF A
5 a+b+c+d	5 MHz	M2	RF A
6 a+b+c+d	5 MHz	M	RF B
7 a+b+c+d	5 MHz	M	RF C
8 a+b+c+d	5 MHz	M	RF D

Remark

The emission at 9 kHz on the plots was not generated by the test object. A complementary measurement with a smaller RBW showed that it was related to the LO feed-through.

The highest fundamental frequency is 2360 MHz. The measurements were made up to 24 GHz (10x2360 MHz = 23 600 GHz).

Appendix 5

Limits

CFR 47 §27.53(a)

Outside a licensee's frequency band(s) of operation the power of any emission shall be attenuated below the transmitter power (P) by the amount indicated in table below, measured with 1 MHz RBW.

Frequency (MHz)	Attenuation (dB)
< 2285	$75 + 10 \log_{10}(p)$
2285 - 2287.5	$72 + 10 \log_{10}(p)$
2287.5 - 2300	$70 + 10 \log_{10}(p)$
2300 - 2305	$43 + 10 \log_{10}(p)$
2305 - 2320	$43 + 10 \log_{10}(p)$
2320 - 2345	$75 + 10 \log_{10}(p)$
2345 - 2360	$43 + 10 \log_{10}(p)$
2360 - 2362.5	$43 + 10 \log_{10}(p)$
2362.5 - 2365	$55 + 10 \log_{10}(p)$
2365 - 2367.5	$70 + 10 \log_{10}(p)$
2367.5 - 2370	$72 + 10 \log_{10}(p)$
> 2370	$75 + 10 \log_{10}(p)$

RSS-195 5.6

Outside a licensee's frequency band(s) of operation the power of any emission shall be attenuated below the transmitter power (P) by the amount indicated in table below, measured with 1 MHz RBW:

Frequency (MHz)	Attenuation (dB)
<2200	$43 + 10 \log_{10}(p)$
2200 - 2285	$75 + 10 \log_{10}(p)$
2285 - 2287.5	$72 + 10 \log_{10}(p)$
2287.5 - 2300	$70 + 10 \log_{10}(p)$
2300 - 2305	$43 + 10 \log_{10}(p)$
2305 - 2320	$43 + 10 \log_{10}(p)$
2320 - 2345	$75 + 10 \log_{10}(p)$
2345 - 2360	$43 + 10 \log_{10}(p)$
2360 - 2362.5	$43 + 10 \log_{10}(p)$
2362.5 - 2365	$55 + 10 \log_{10}(p)$
2365 - 2367.5	$70 + 10 \log_{10}(p)$
2367.5 - 2370	$72 + 10 \log_{10}(p)$
2370 - 2395	$75 + 10 \log_{10}(p)$
>2395	$43 + 10 \log_{10}(p)$

Complies?	Yes
-----------	-----



Appendix 5

Appendix 5

Diagram 1a:

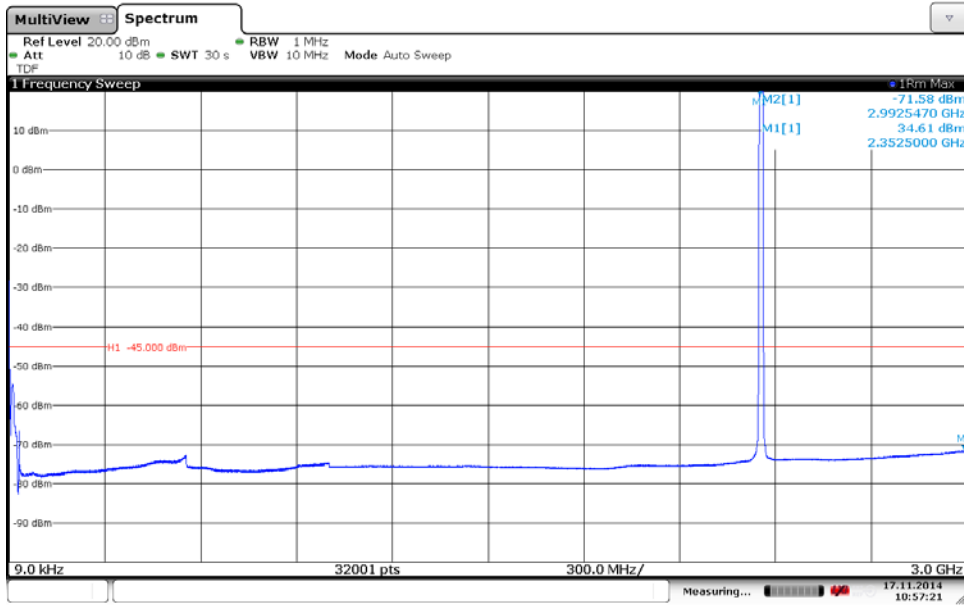

Date: 17 NOV 2014 10:57:21

Diagram 1b:

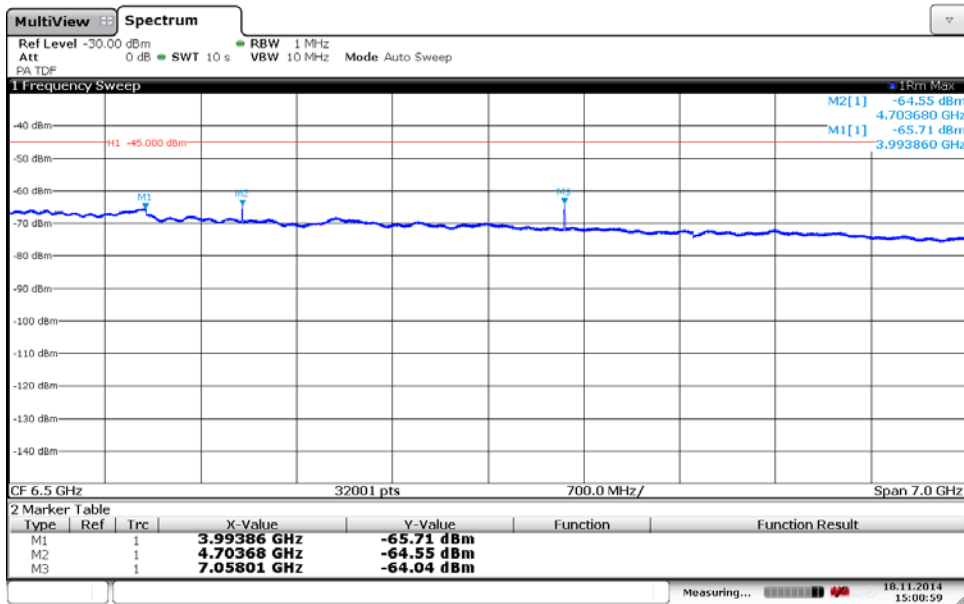

Date: 18 NOV 2014 15:01:00

Appendix 5

Diagram 1c:

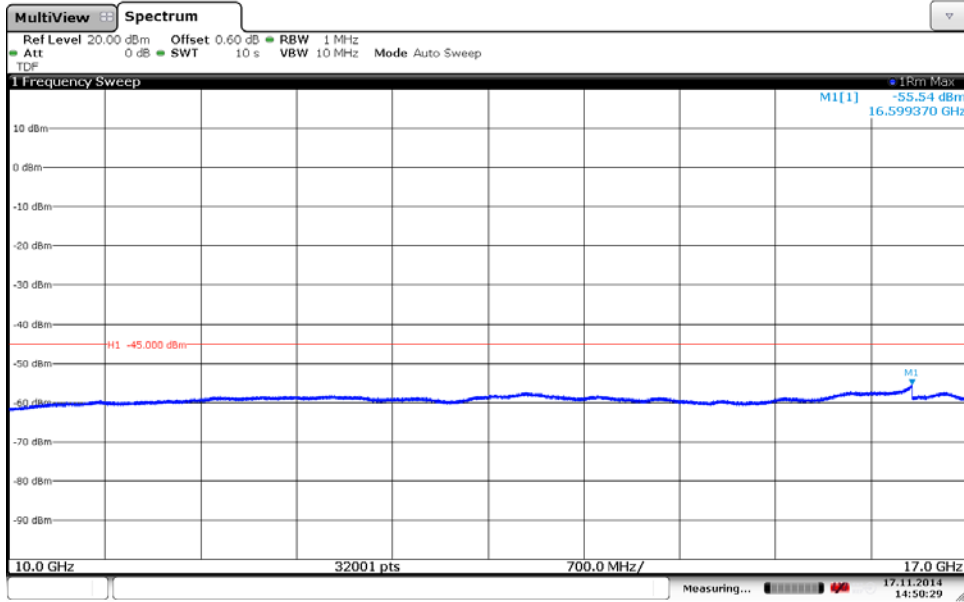
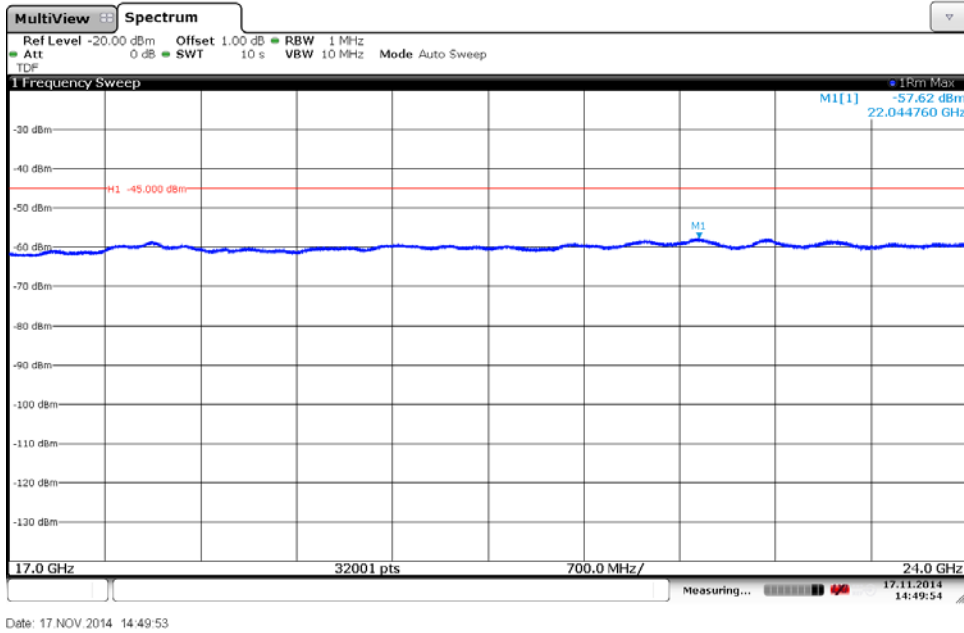

Diagram 1d:



Appendix 5

Diagram 2a:

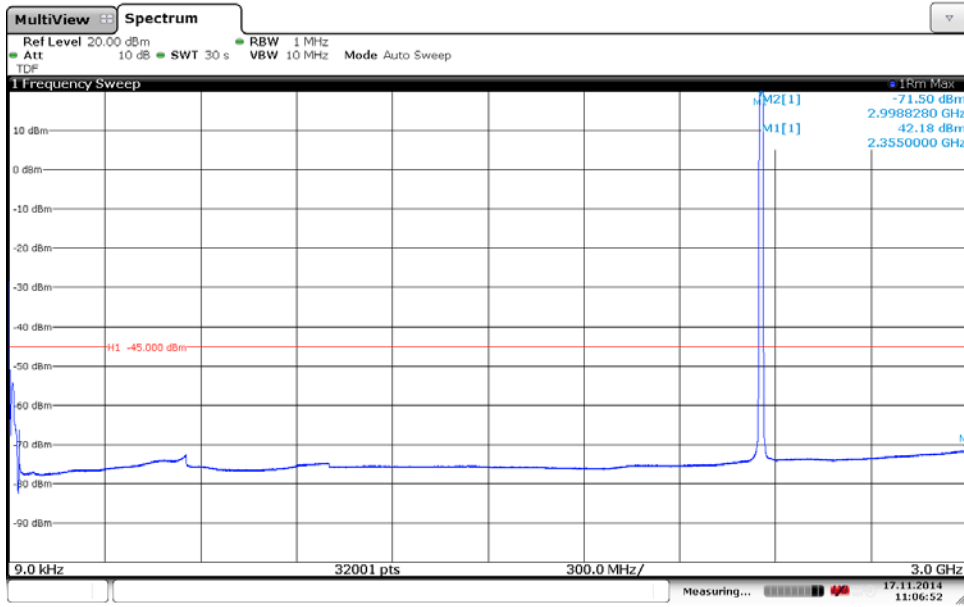
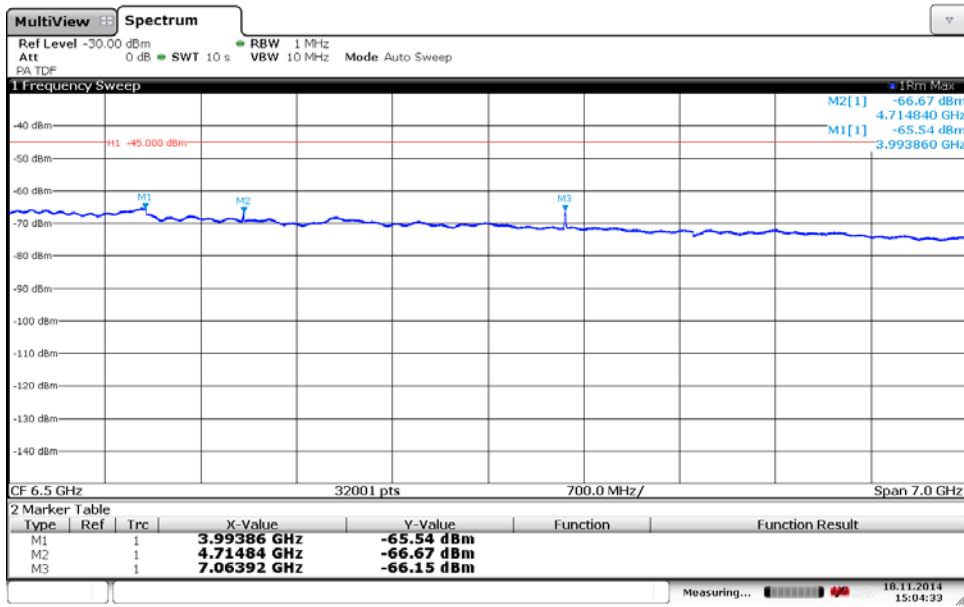

Diagram 2b:



Appendix 5

Diagram 2c:

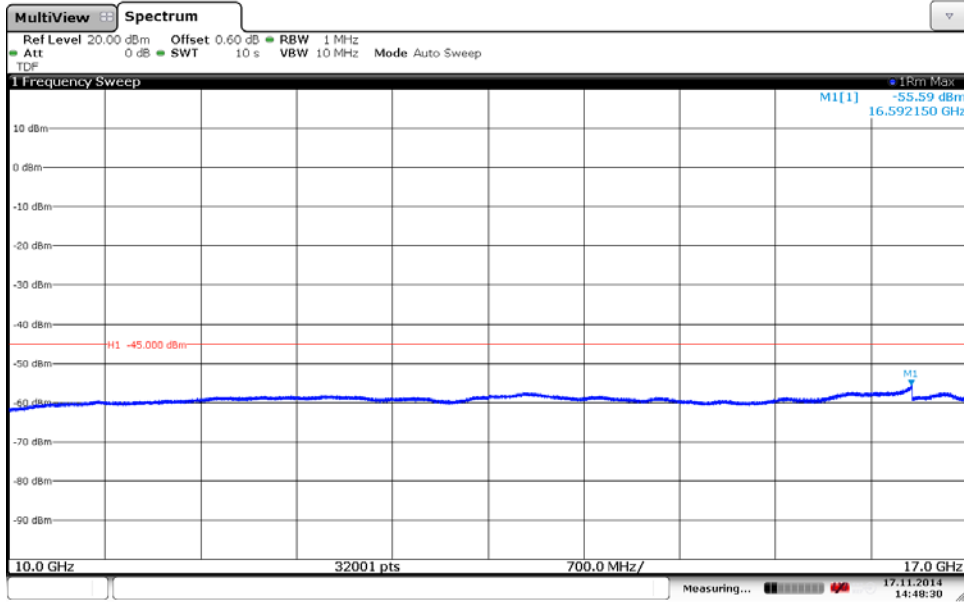
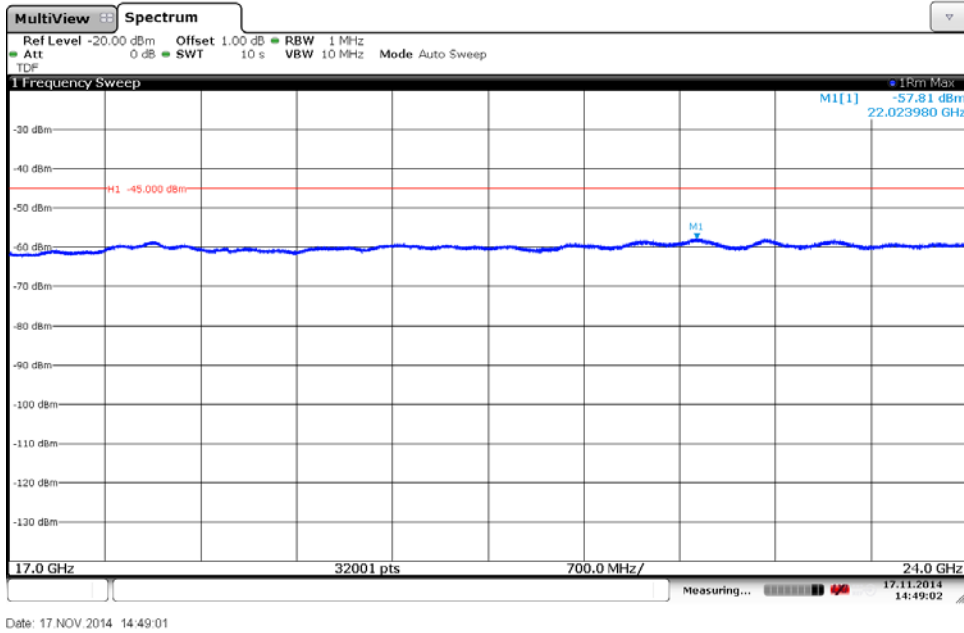

Diagram 2d:



Appendix 5

Diagram 3a:

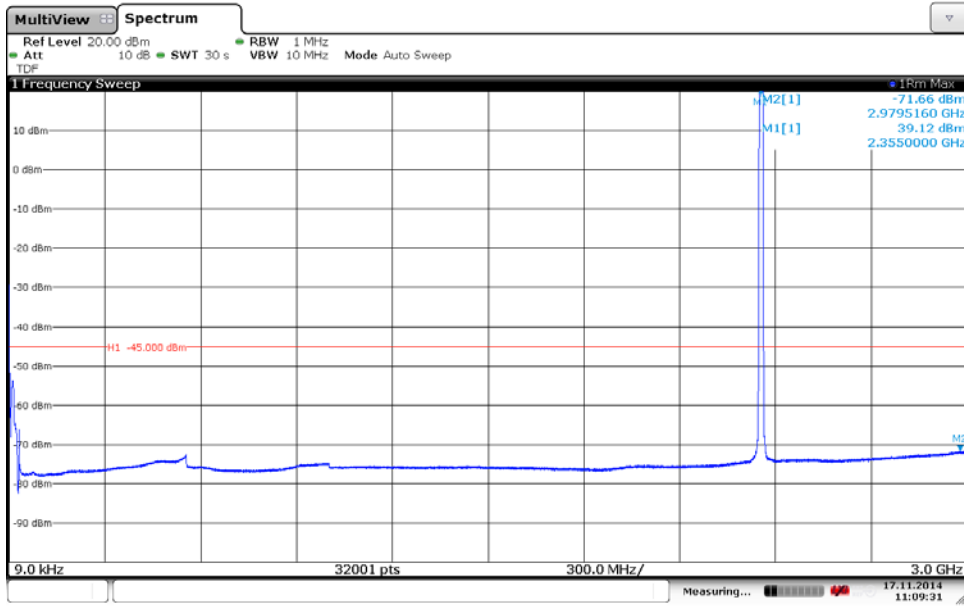
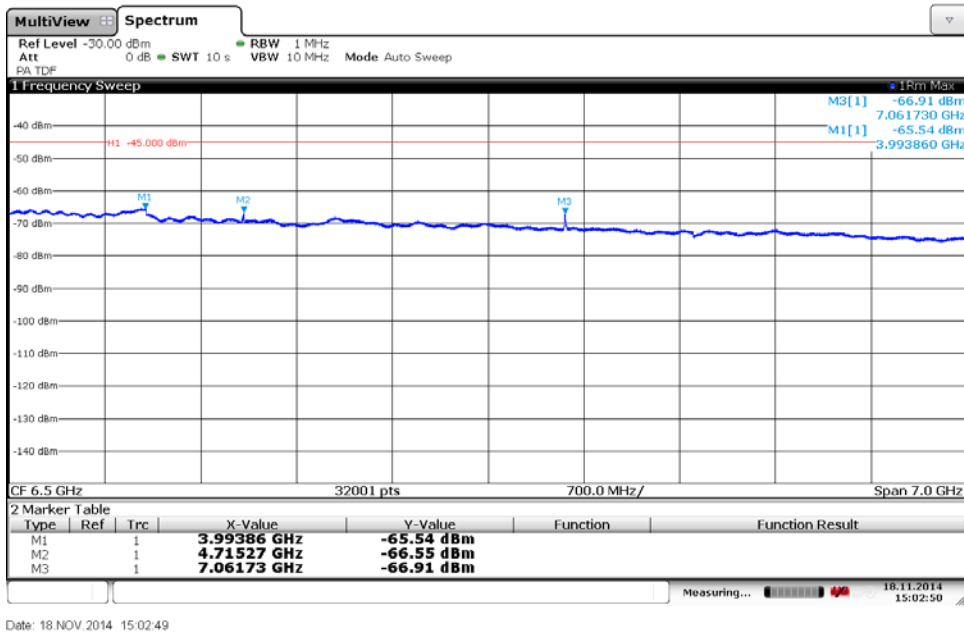

Diagram 3b:



Appendix 5

Diagram 3c:

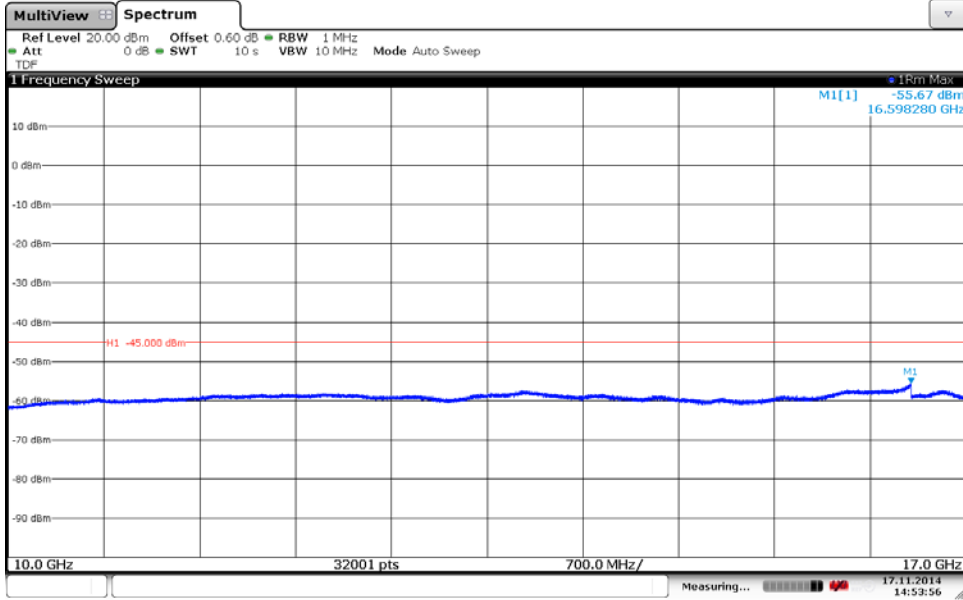
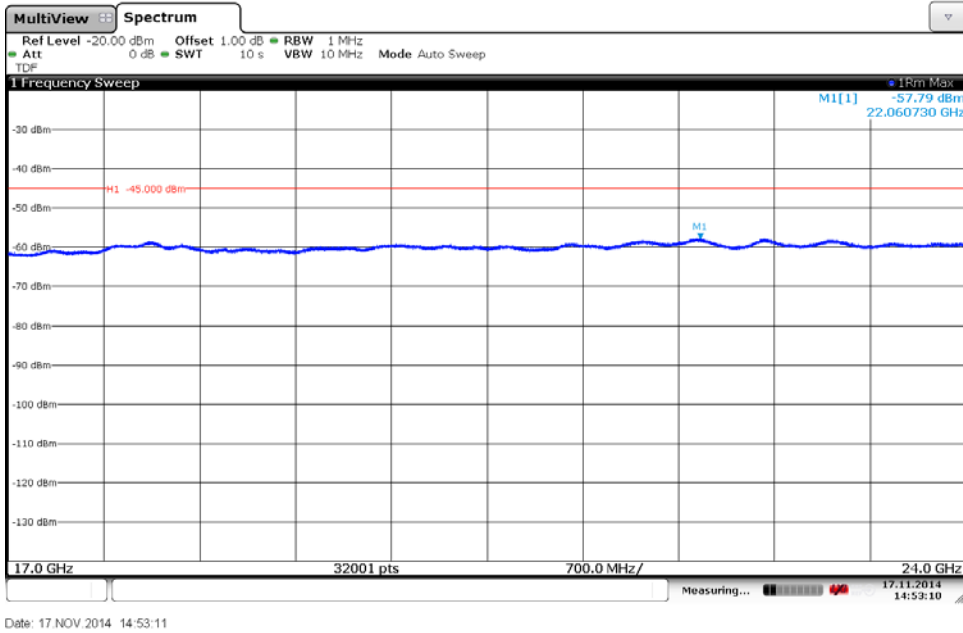

Diagram 3d:



Appendix 5

Diagram 4a:

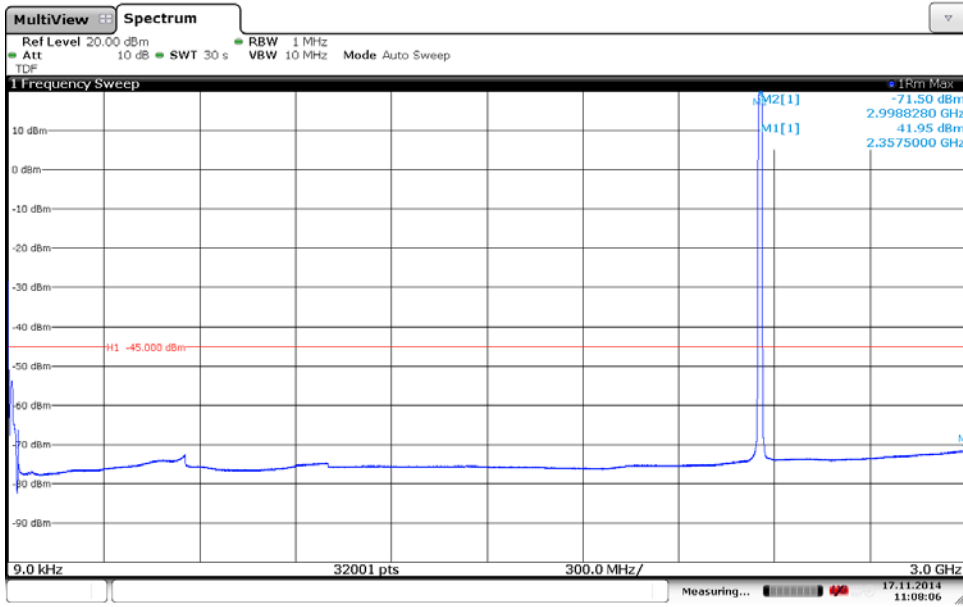
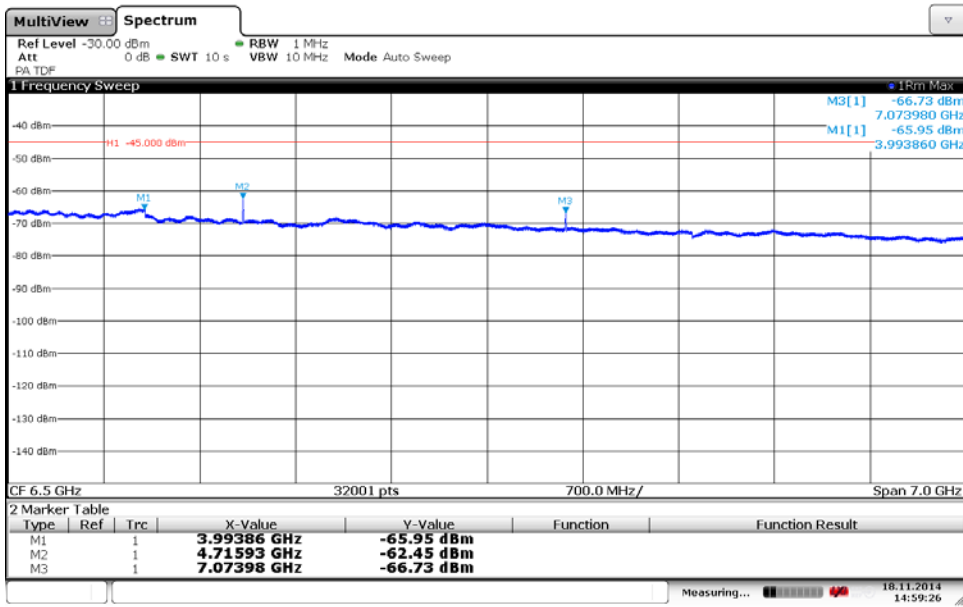

Diagram 4b:



Appendix 5

Diagram 4c:

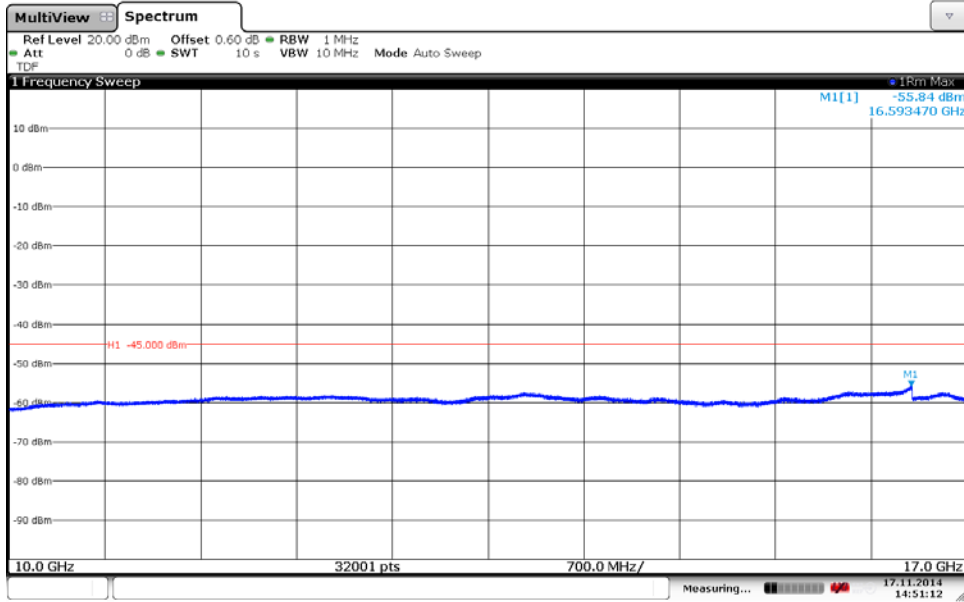
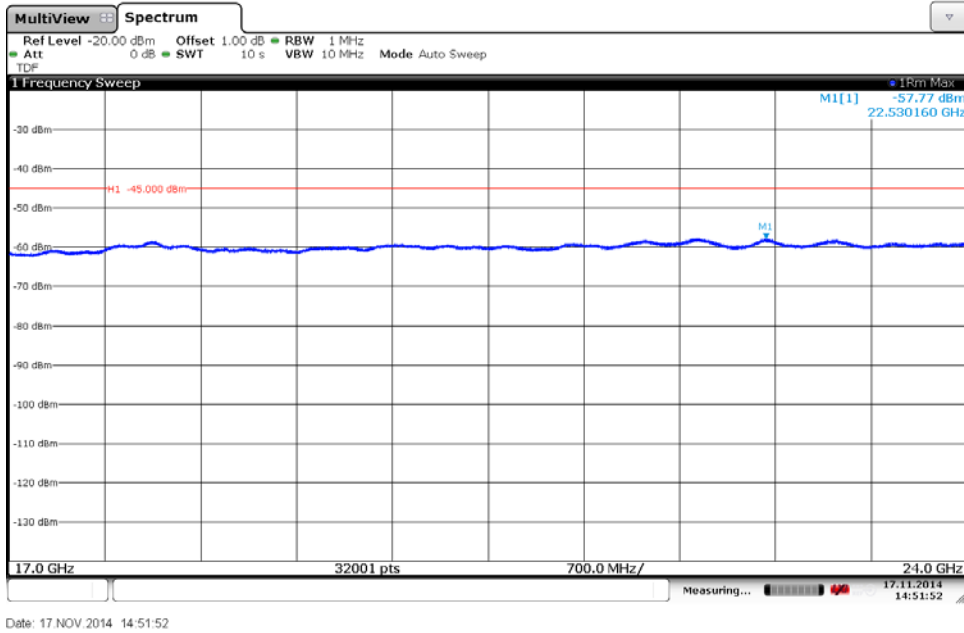

Diagram 4d:



Appendix 5

Diagram 5a:

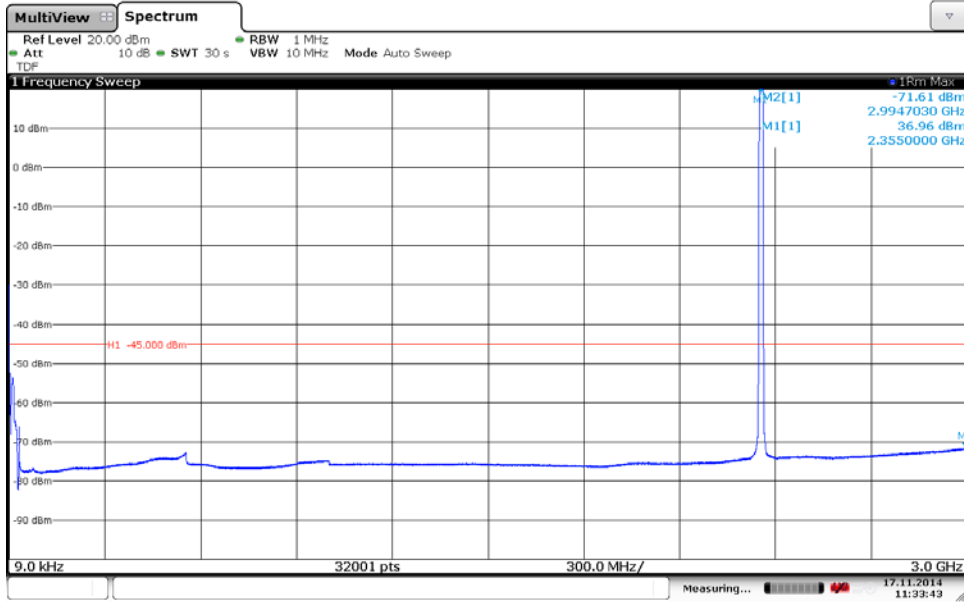
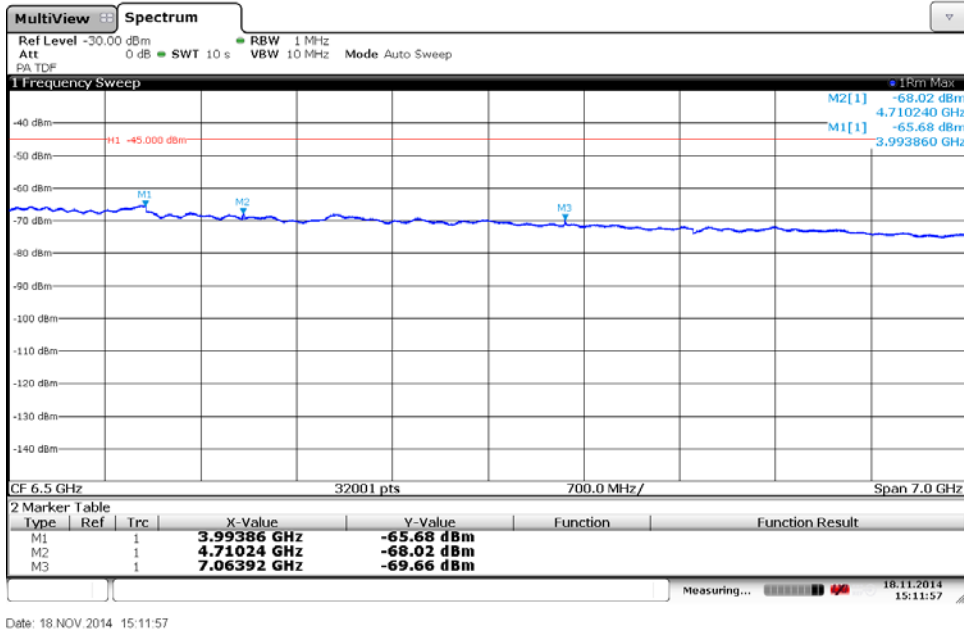
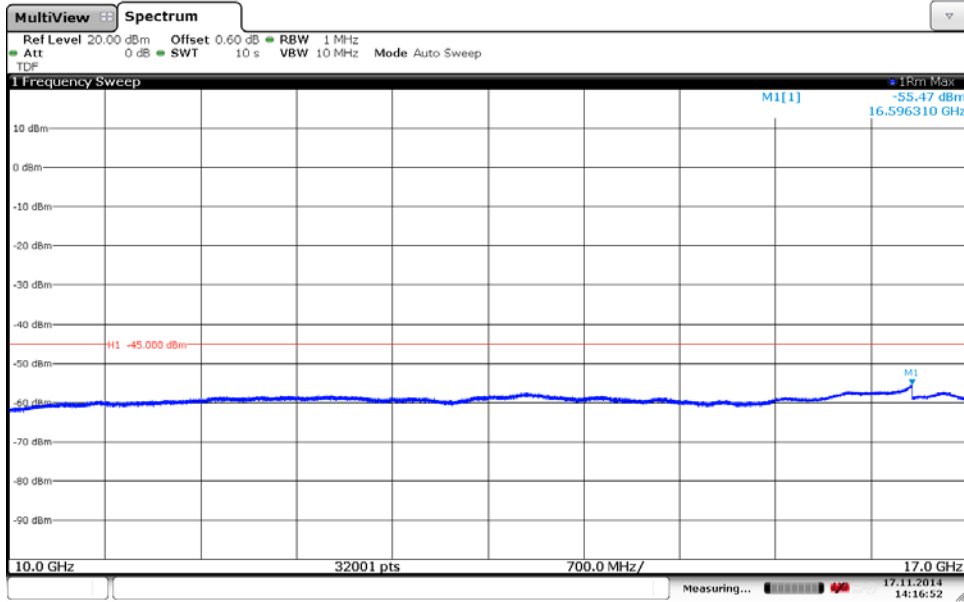

Diagram 5b:



Appendix 5

Diagram 5c:



Date: 17 NOV. 2014 14:16:51

Diagram 5d:

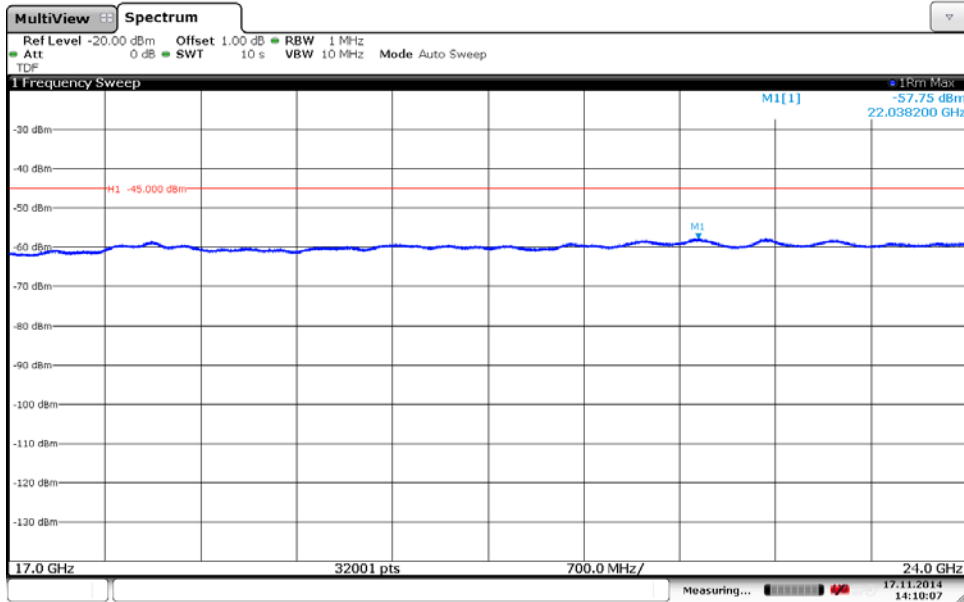

Date: 17 NOV. 2014 14:10:07

Appendix 5

Diagram 6a:

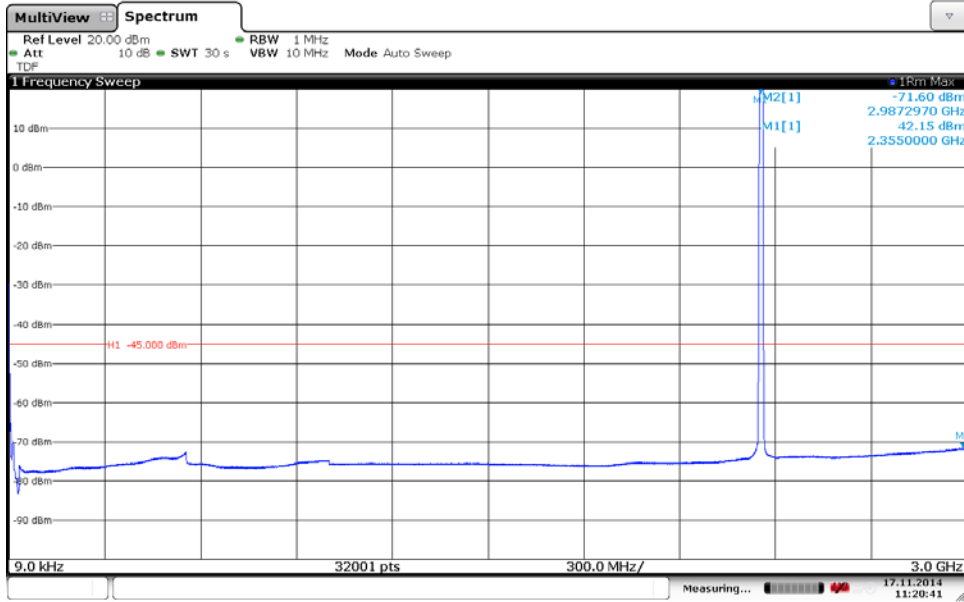
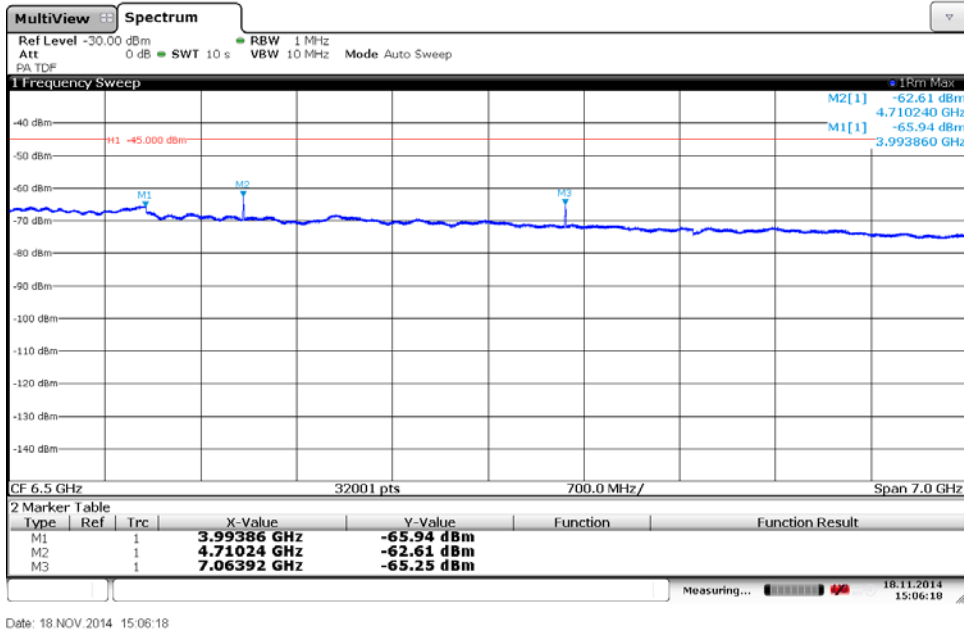

Diagram 6b:



Appendix 5

Diagram 6c:

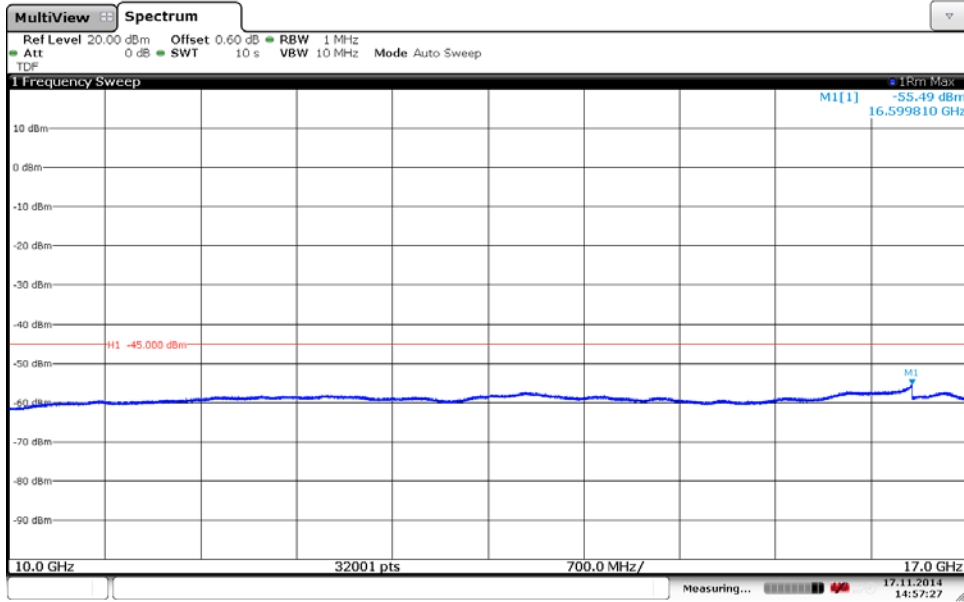
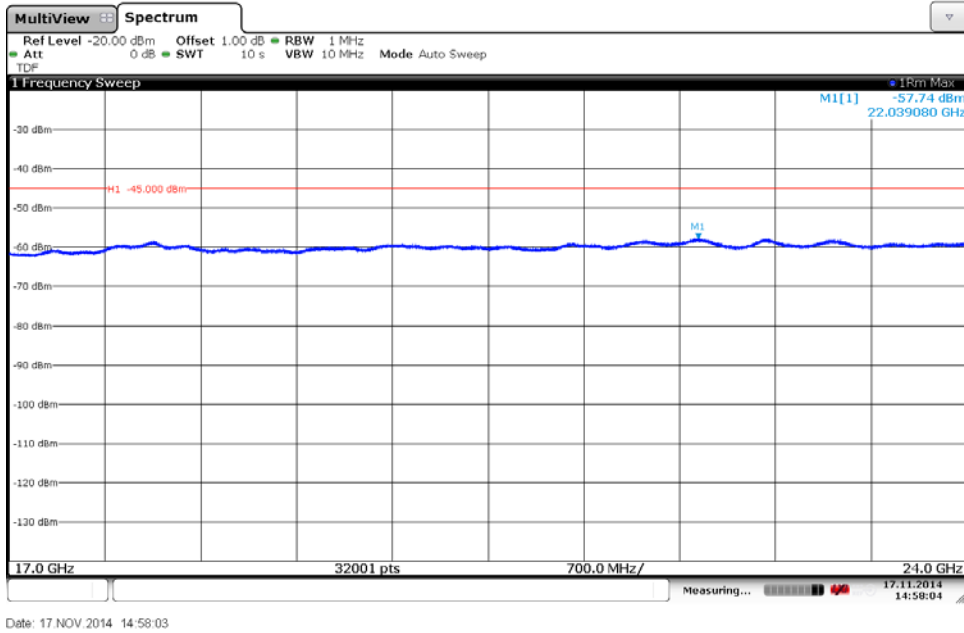
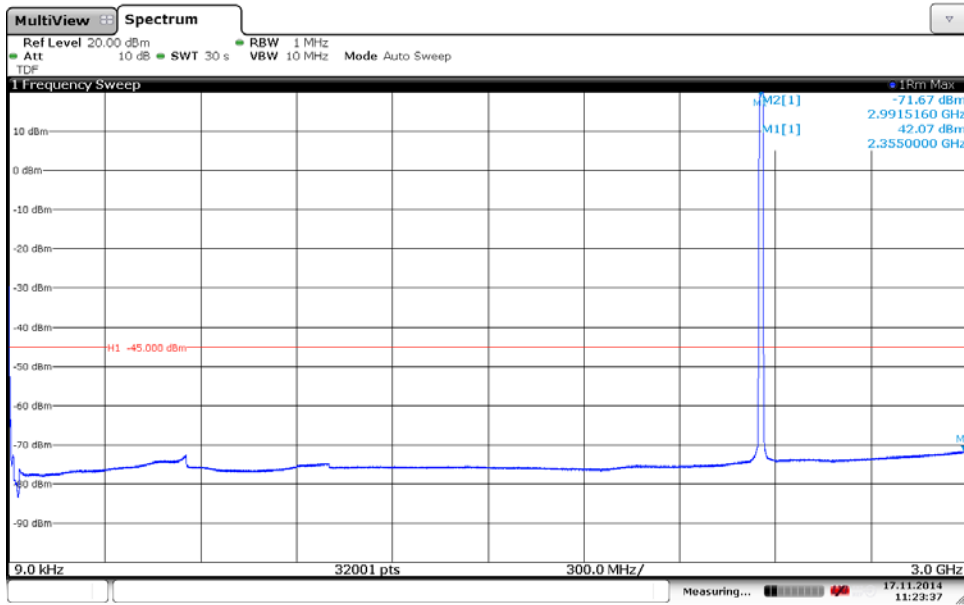

Diagram 6d:



Appendix 5

Diagram 7a:



Date: 17 NOV. 2014 11:23:36

Diagram 7b:

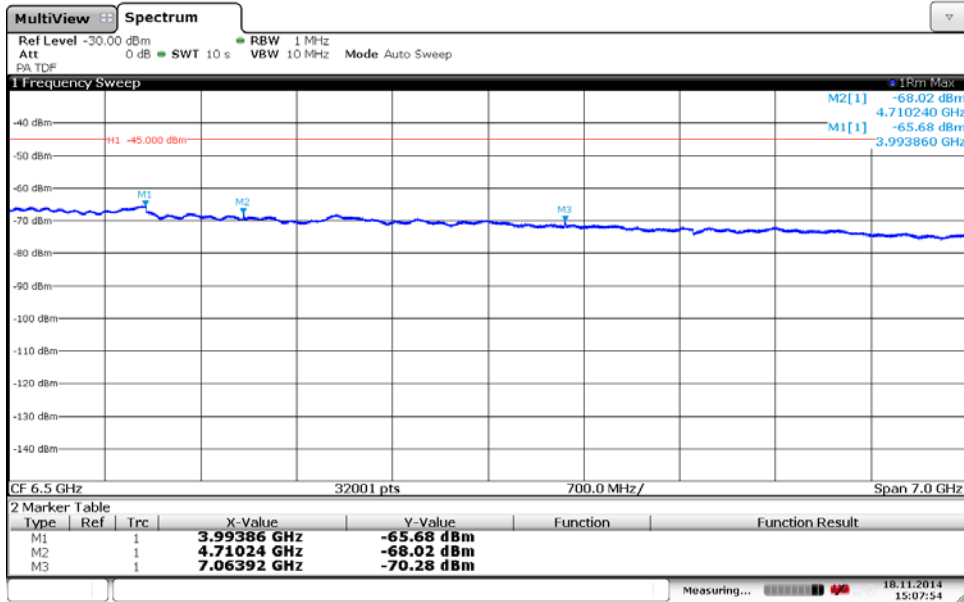

Date: 18 NOV. 2014 15:07:54

Appendix 5

Diagram 7c:

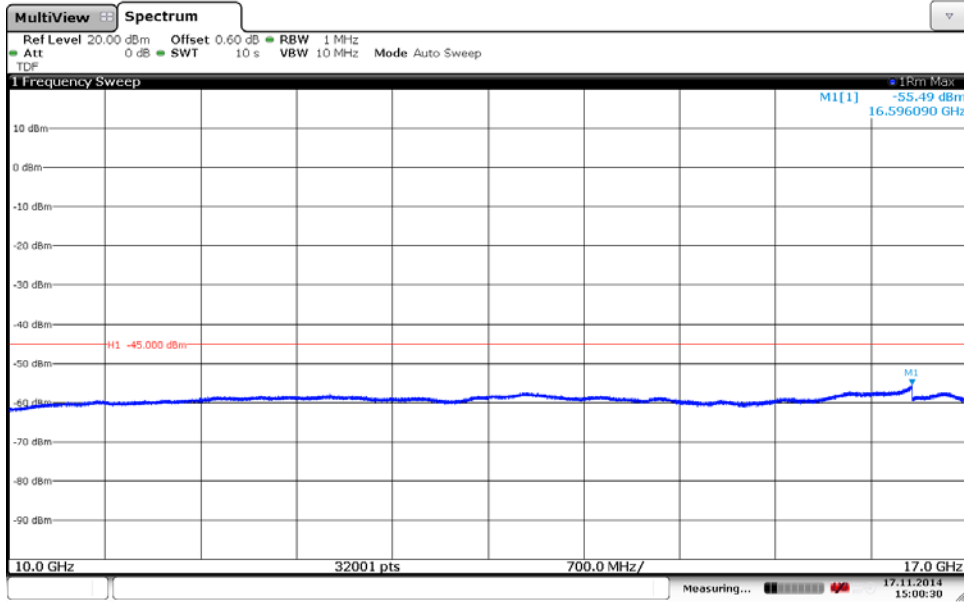
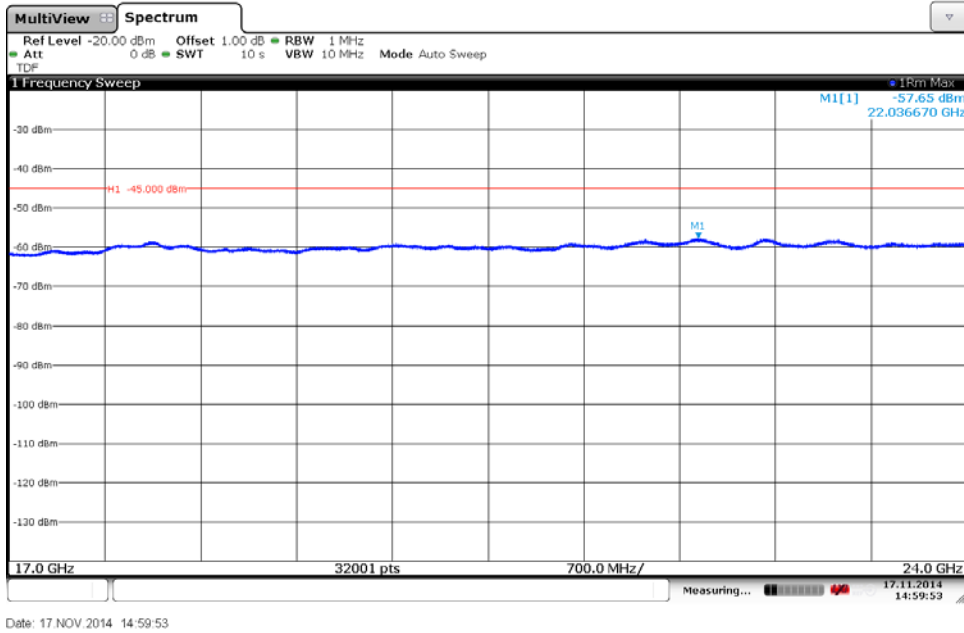

Diagram 7d:



Appendix 5

Diagram 8a:

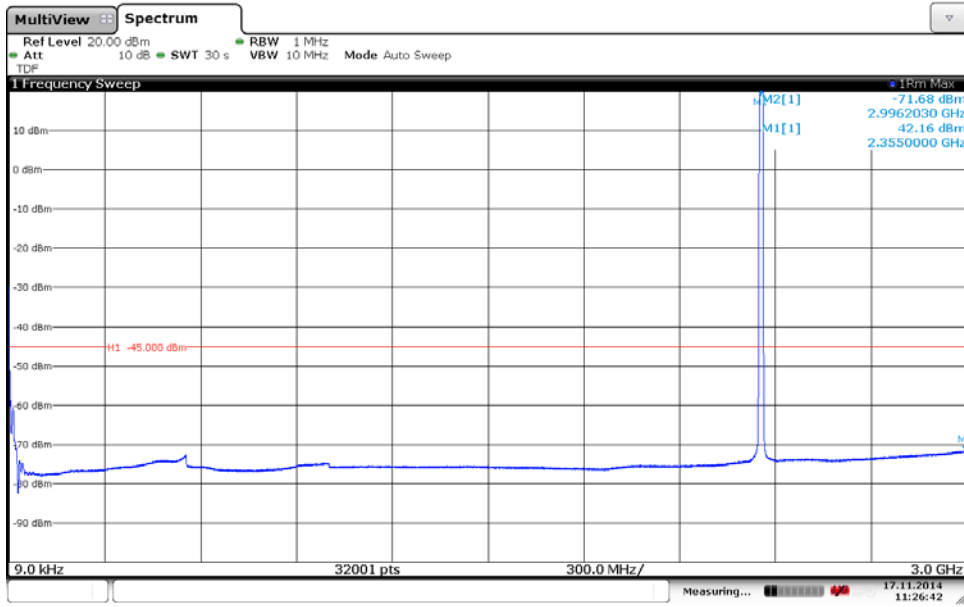
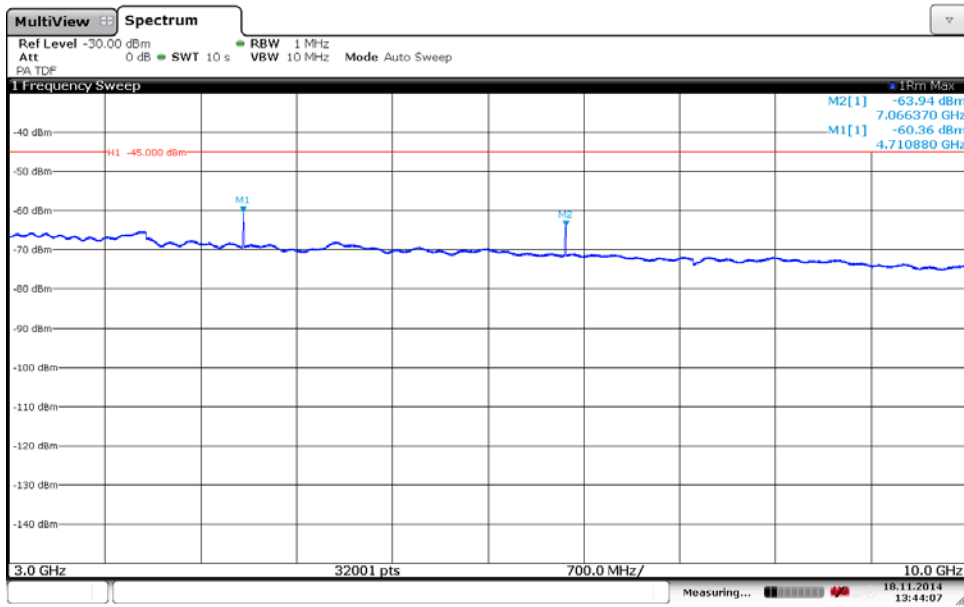

Diagram 8b:



Appendix 5

Diagram 8c:

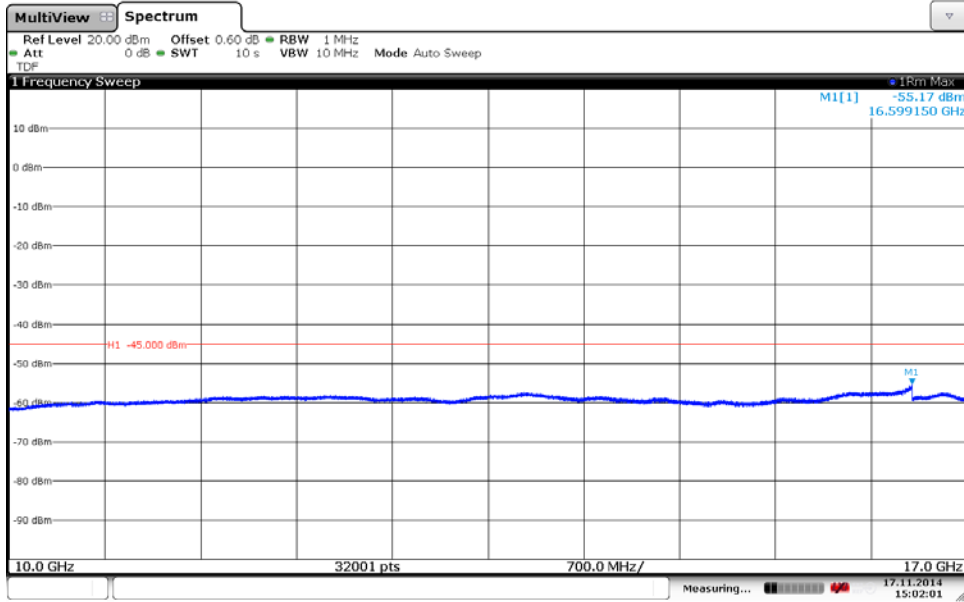
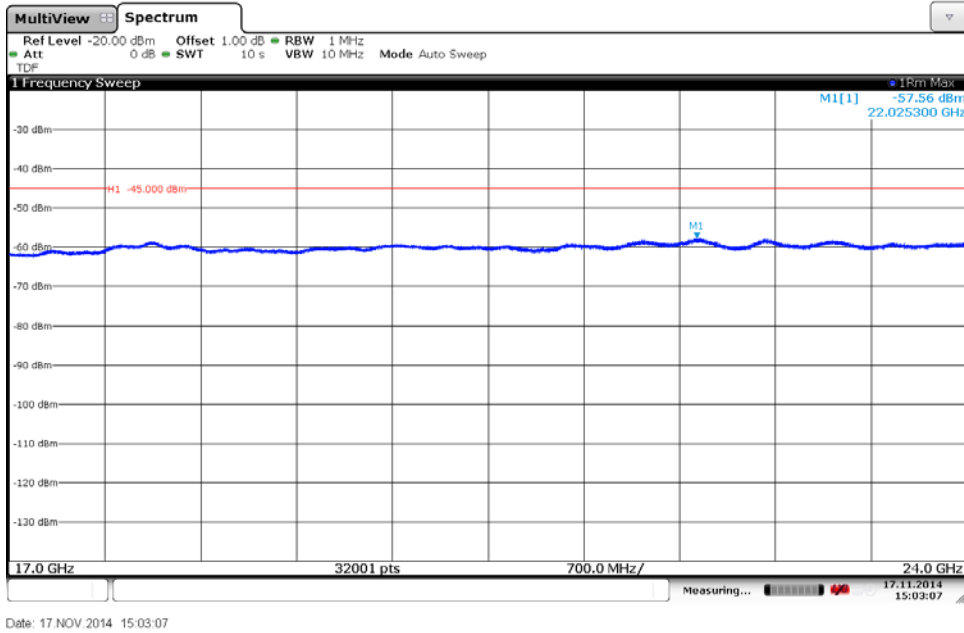

Diagram 8d:



Appendix 6

Field strength of spurious radiation measurements according to 47 CFR 27.53 (a) / IC RSS-195 5.6

Date	Temperature	Humidity
2014-11-11	23°C ± 3°C	40 % ± 5 %
2014-11-12	23°C ± 3°C	33 % ± 5 %
2014-11-13	23°C ± 3°C	38 % ± 5 %

Test set-up and procedure

The test sites are listed at FCC, Columbia with registration number: 93866. The test site complies with RSS-Gen, Industry Canada file no. 3482A-1.

The measurements were performed with both horizontal and vertical polarization of the antenna. The antenna distance was 3 m in the frequency range 30 MHz – 18 GHz and 1 m in the frequency range 18 GHz – 24 GHz.

The measurement was performed with a RBW of 1 MHz.

A propagation loss in free space was calculated. The used formula was

$$\gamma = 20 \log \left(\frac{4\pi D}{\lambda} \right), \gamma \text{ is the propagation loss and } D \text{ is the antenna distance.}$$

The measurement procedure was as the following:

1. A pre-measurement is performed with peak detector. For measurement < 1 GHz the test object is measured in eight directions with the antenna at three heights, 1.0 m, 1.5 m and 2.0. For measurements > 1 GHz the test object was measured in seventeen directions with the antenna at three heights, 1.0 m, 1.5 m and 2.0.
2. Spurious radiation on frequencies closer than 20 dB to the limit in the pre-measurement is scanned 0-360 degrees and the antenna is scanned 1- 4 m for maximum response. The emission is then measured with the RMS detector and the RMS value is reported. Frequencies closer than 10 dB to the limit when measured with the RMS detector were measured with the substitution method according to the standard.

Appendix 6

The test set-up during the spurious radiation measurements is shown in the picture below:

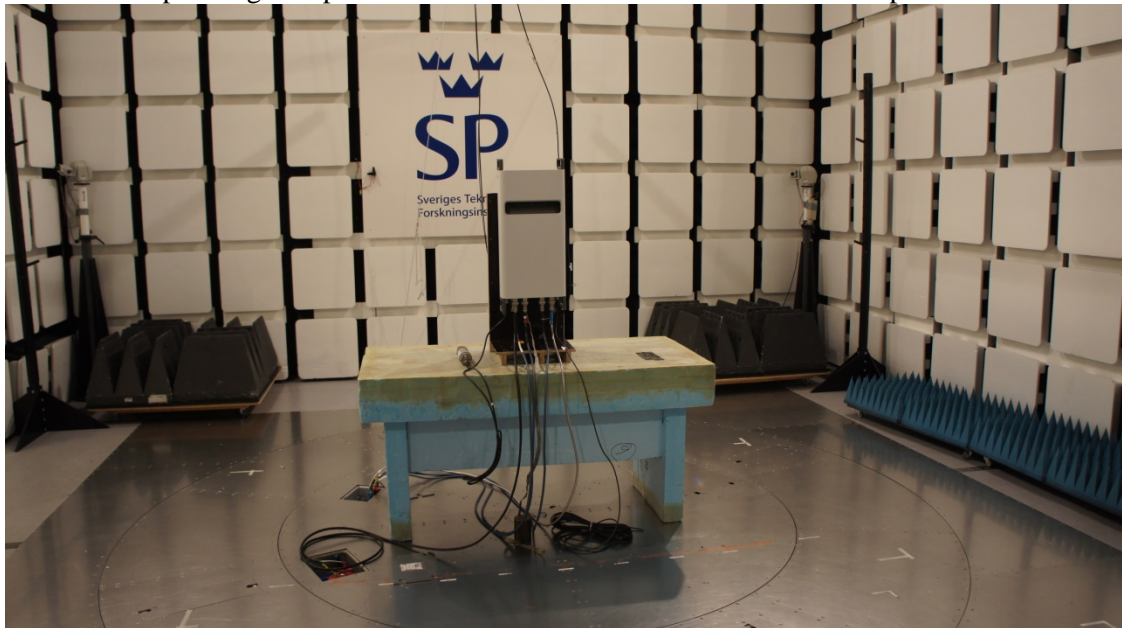

Measurement equipment

Measurement equipment	SP number
Semi anechoic chamber	503 881
R&S ESU 26	901 553
R&S ESU 40	901 385
EMC 32 ver. 8.52.0	503 899
Chase Bilog Antenna CBL 6111A	503 182
EMCO Horn Antenna 3115	502 175
FLANN Std gain 16240-25	503 939
FLANN Std gain 18240-25	503 900
FLANN Std gain 20240-20	503 674
FLANN Std gain 22240-20	503 674
µComp Nordic, Low Noise Amplifier	901 545
Schwarzbeck preamplifier BBV 9742	504 085
Miteq 18-40 GHz, Low Noise Amplifier	503 278
HP Filter 3-18 GHz	503 739
Temperature and humidity meter, Testo 625	504 188

Appendix 6

Tested configurations

B
M
M2
T

Results, representing worst case

T, BW 5 MHz: Diagram 1 a-i

Measurement uncertainty:

3.2 dB up to 18 GHz

Limits

CFR 47 §27.53(a)

Outside a licensee's frequency band(s) of operation the power of any emission shall be attenuated below the transmitter power (P) by the amount indicated in table below, measured with 1 MHz RBW.

Frequency (MHz)	Attenuation (dB)
< 2285	$75 + 10 \log_{10}(p)$
2285 - 2287.5	$72 + 10 \log_{10}(p)$
2287.5 - 2300	$70 + 10 \log_{10}(p)$
2300 - 2305	$43 + 10 \log_{10}(p)$
2305 - 2320	$43 + 10 \log_{10}(p)$
2320 - 2345	$75 + 10 \log_{10}(p)$
2345 - 2360	$43 + 10 \log_{10}(p)$
2360 - 2362.5	$43 + 10 \log_{10}(p)$
2362.5 - 2365	$55 + 10 \log_{10}(p)$
2365 - 2367.5	$70 + 10 \log_{10}(p)$
2367.5 - 2370	$72 + 10 \log_{10}(p)$
> 2370	$75 + 10 \log_{10}(p)$

Appendix 6

RSS-195 5.6

Outside a licensee's frequency band(s) of operation the power of any emission shall be attenuated below the transmitter power (P) by the amount indicated in table below, measured with 1 MHz RBW:

Frequency (MHz)	Attenuation (dB)
<2200	$43 + 10 \log_{10}(p)$
2200 - 2285	$75 + 10 \log_{10}(p)$
2285 - 2287.5	$72 + 10 \log_{10}(p)$
2287.5 - 2300	$70 + 10 \log_{10}(p)$
2300 - 2305	$43 + 10 \log_{10}(p)$
2305 - 2320	$43 + 10 \log_{10}(p)$
2320 - 2345	$75 + 10 \log_{10}(p)$
2345 - 2360	$43 + 10 \log_{10}(p)$
2360 - 2362.5	$43 + 10 \log_{10}(p)$
2362.5 - 2365	$55 + 10 \log_{10}(p)$
2365 - 2367.5	$70 + 10 \log_{10}(p)$
2367.5 - 2370	$72 + 10 \log_{10}(p)$
2370 - 2395	$75 + 10 \log_{10}(p)$
>2395	$43 + 10 \log_{10}(p)$

Complies?	Yes
-----------	-----

Appendix 6

Diagram 1a:

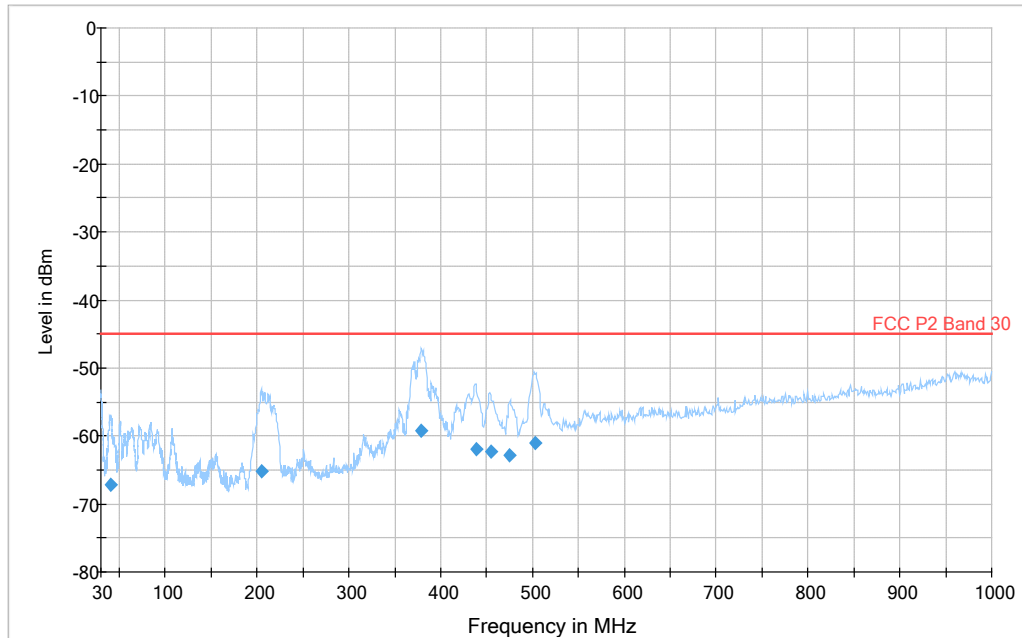

Final RMS Result

Frequency (MHz)	RMS (dBm)	Meas. Time (ms)	Bandwidth (kHz)	Height (cm)	Polarization	Azimuth (deg)	Corr. (dB)	Margin (dB)	Limit (dBm)
40.658	-67.1	5000.0	1000.000	100.0	V	250.0	-79.3	22.1	-45.0
204.549	-65.2	5000.0	1000.000	173.0	V	0.0	-82.2	20.2	-45.0
378.724	-59.3	5000.0	1000.000	100.0	V	8.0	-75.8	14.3	-45.0
438.661	-62.0	5000.0	1000.000	112.0	V	122.0	-74.0	17.0	-45.0
455.368	-62.3	5000.0	1000.000	116.0	V	115.0	-73.5	17.3	-45.0
475.524	-62.8	5000.0	1000.000	100.0	V	268.0	-73.3	17.8	-45.0
502.612	-61.1	5000.0	1000.000	100.0	V	92.0	-72.6	16.1	-45.0

Appendix 6

Diagram 1b:

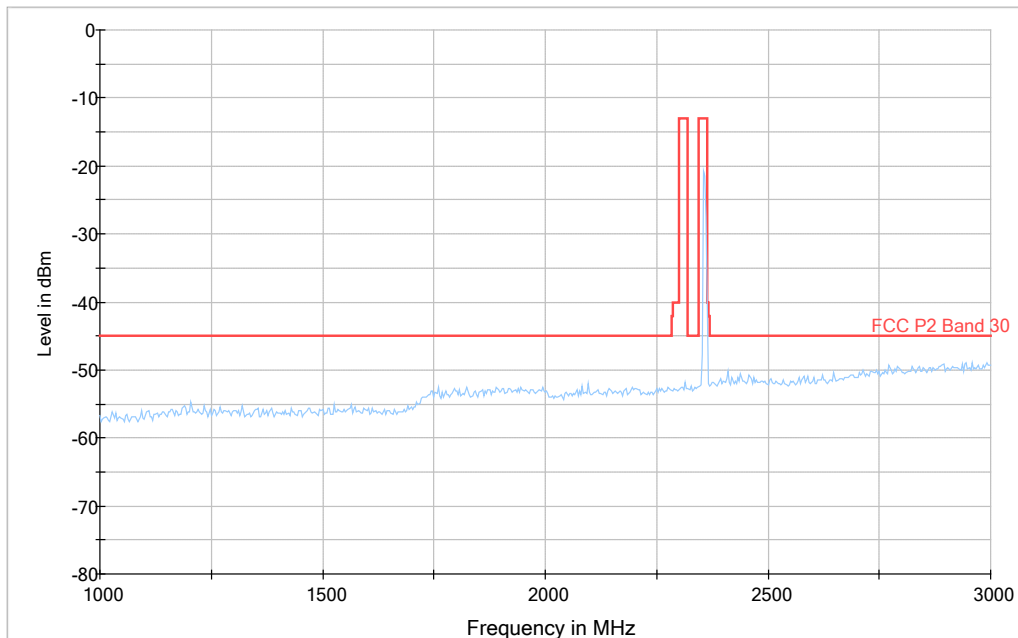
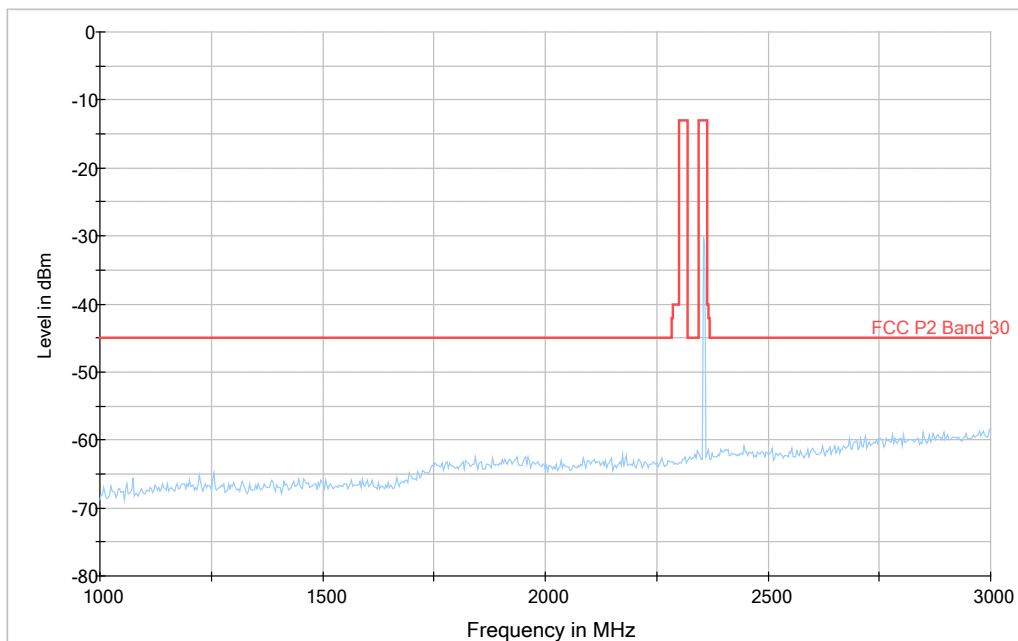

Diagram 1c: pre-measurement with RBW 100 kHz



Note: In this measurement the noise floor was close to the limit. A verification with 100 kHz RBW shows that there are no spurious emission in the frequency range 1-3 GHz.

Appendix 6

Diagram 1d: (zoom of diagram 1b)

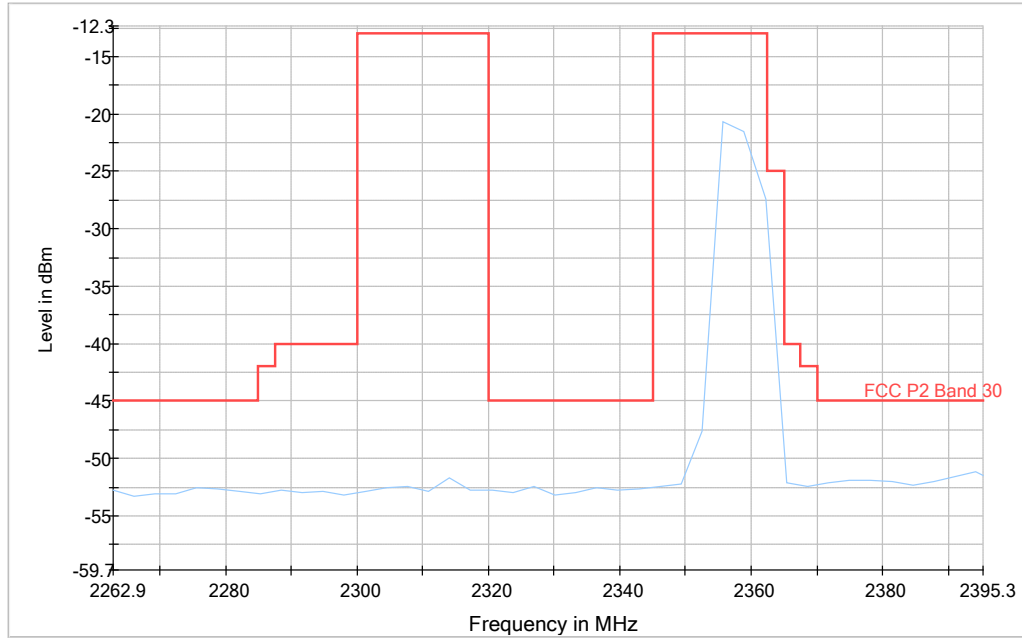
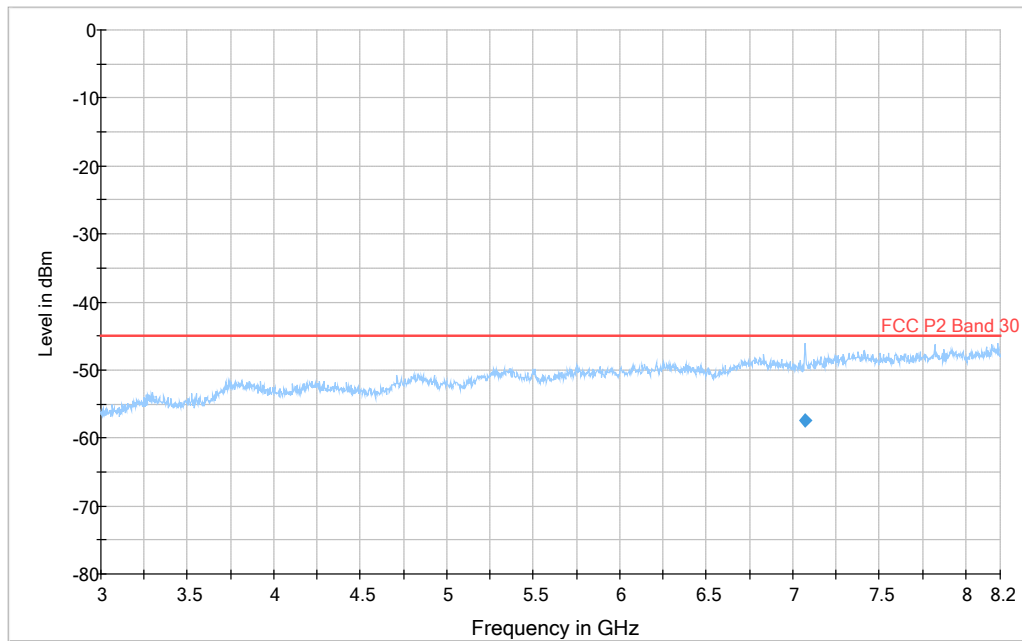

Diagram 1e:



Final RMS Result

Frequency (MHz)	RMS (dBm)	Meas. Time (ms)	Bandwidth (kHz)	Height (cm)	Polarization	Azimuth (deg)	Corr. (dB)	Margin (dB)	Limit (dBm)
7072.563	-57.5	5000.0	1000.000	100.0	V	19.0	-99.0	12.5	-45.0

Appendix 6

Diagram 1f: pre-measurement with RBW 100 kHz

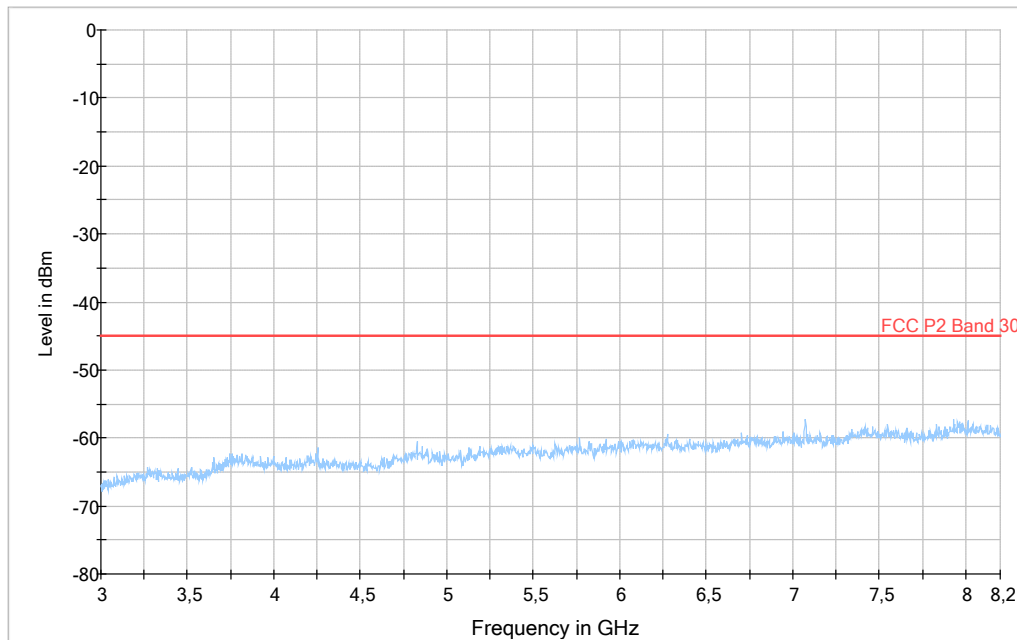

Note: In this measurement the noise floor was close to the limit. A verification with 100 kHz RBW shows that there are no spurious emission in the frequency range 1-3 GHz.

Diagram 1g:

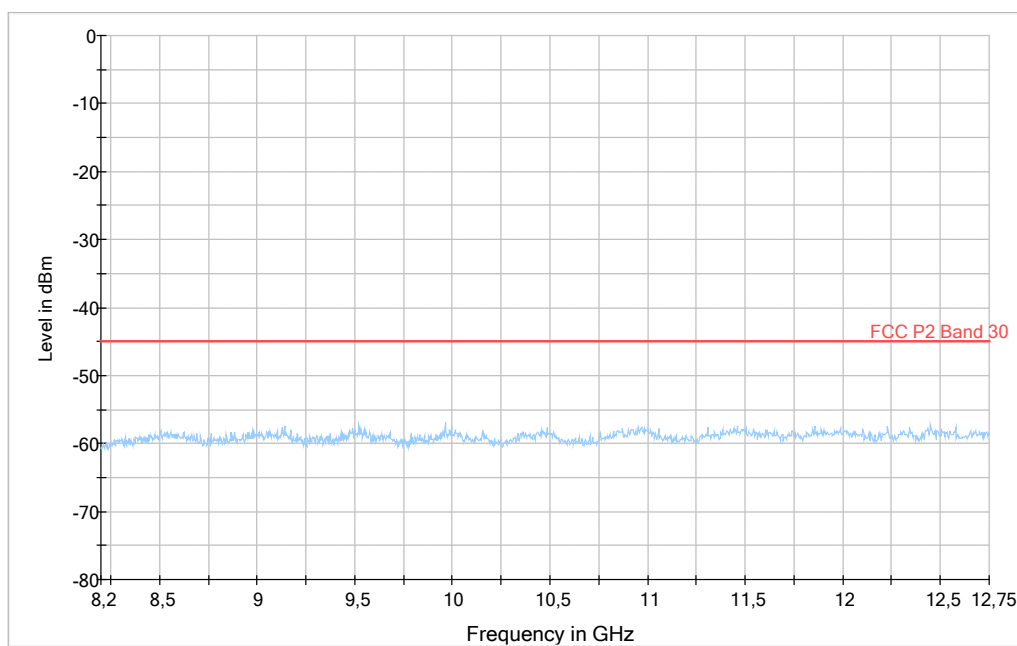

Appendix 6

Diagram 1h:

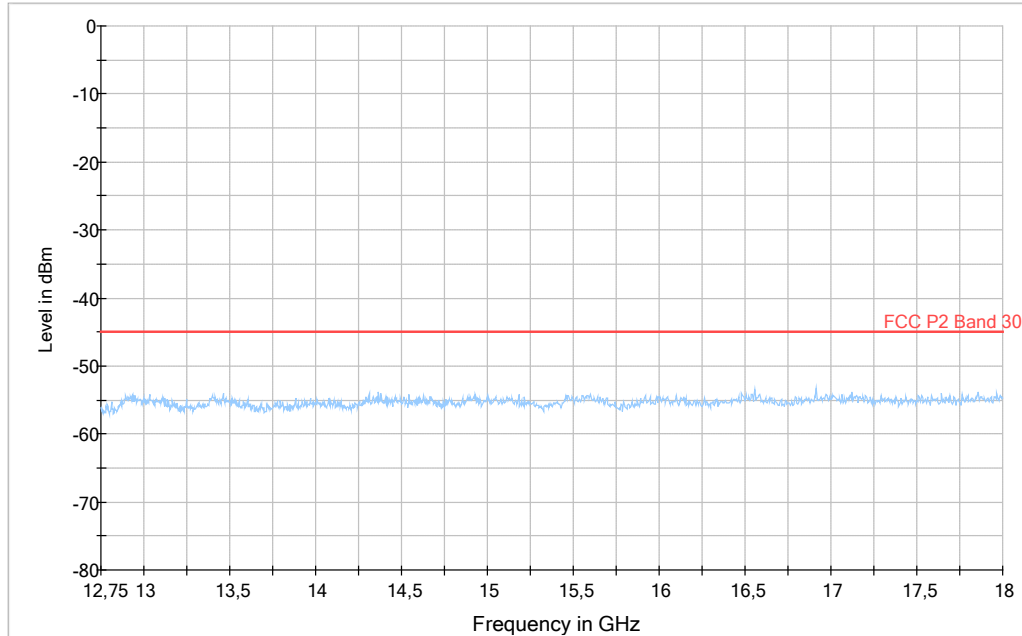
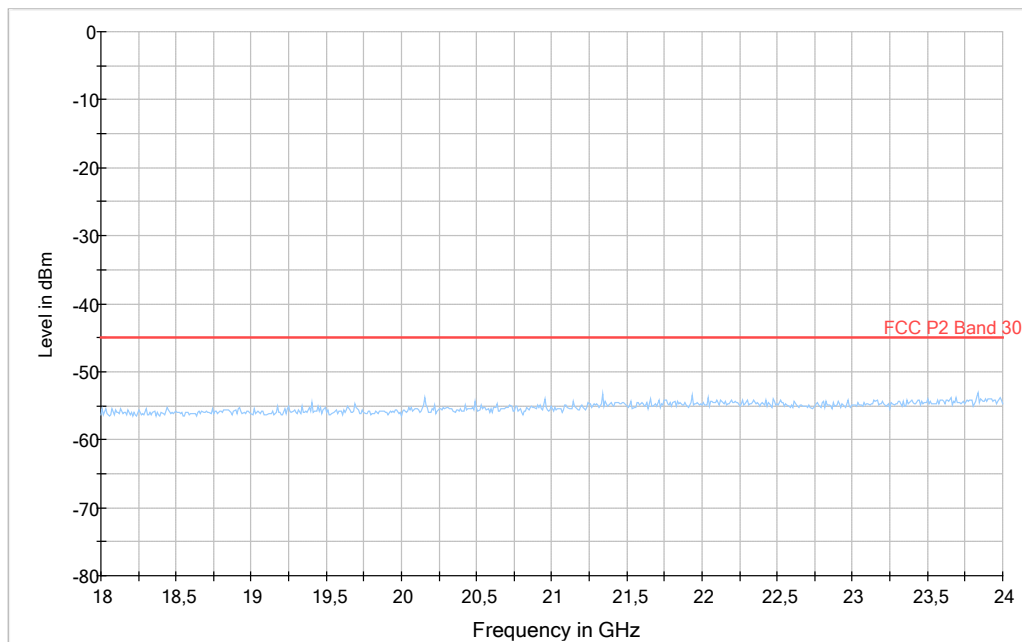

Diagram 1i:



Appendix 7

Frequency stability measurements according to CFR 47 §27.54 / IC RSS 195 5.4

Date	Temperature	Humidity
2014-11-19	23 °C ± 3 °C	35 % ± 5 %
2014-11-20	23 °C ± 3 °C	33 % ± 5 %
2014-11-21	23 °C ± 3 °C	31 % ± 5 %

Test set-up and procedure

The measurement was made per GPP TS 36.141 V12.4.0 (2014-06) 6.5.1. The output was connected to a spectrum analyzer. The spectrum analyzer was connected to an external 10 MHz reference standard during the measurements.

The measurement was also made per IC RSS 130 4.3. Using a resolution bandwidth of 1% of the occupied bandwidth, a reference point at the unwanted emission level which complies with the attenuation of $43 + 10 \log_{10} p$ (watts) (i.e. -13dBm) (for 4x 4MIMO -19dBm) at the band edge of the lowest and highest channel was selected, and the frequency at these points was recorded as fL and fH respectively.

Measurement equipment	SP number
R&S FSW	902 073
R&S FSQ 40	504 143
RF attenuator	902 282
Temperature Chamber	503 360
Testo 635, temperature and humidity meter	504 203
Multimeter Fluke 87	502 190

Appendix 7

Results

Nominal Voltage -48 V DC

Maximum output power at mid channel (M)

Channel Bandwidth 5MHz

Test conditions		Frequency error (Hz)
Supply voltage DC (V)	T (°C)	Test model E-TM1.1
-48.0	+20	+11
-55.2	+20	+9
-40.8	+20	+10
-48.0	+30	+10
-48.0	+40	+12
-48.0	+50	+8
-48.0	+10	+11
-48.0	0	+10
-48.0	-10	-13
-48.0	-20	-9
-48.0	-30	-9
Maximum freq. error (Hz)		13
Measurement uncertainty		$< \pm 1 \times 10^{-7}$

3GPP TS 36.141 V12.4.0 (2014-06) 6.5.1, limit: ± 0.05 PPM ± 12 Hz (± 129.75 Hz)

Appendix 7

Rated output power level at connector RF A (maximum): 44 dBm (25 W)

Test conditions			Frequency margin to band edge at -19dBm			
Supply voltage DC [V]	Temp [°C].	Carrier Bandwidth [MHz]	Test frequency Symbolic name Bottom		Test frequency Symbolic name Top	
			fL [MHz]	Offset to lower band edge (2350 MHz) [kHz]	fH [MHz]	Offset to upper band edge (2360 MHz) [kHz]
-48.0	+20	5	2350.041	41	2359.959	41
-48.0	+20	10	2350.255	255	2359.756	244

Measurements according to IC RSS 130 4.3.

The frequency error results clearly shows that the frequency stability is good enough to ensure that the transmitted carrier stay within the operating band.



Appendix 7

Remark

It was deemed sufficient to test one combination of TX frequency, channel bandwidth configuration and test model (modulation), as all combinations share a common internal reference to derive the TX frequency from.

Limits

CFR 47 §27.54:

The frequency stability shall be sufficient to ensure that the fundamental emissions stay within the authorized bands of operation.

RSS-195 5.4 Frequency:

The frequency stability shall be sufficient to ensure that the emission bandwidth stays within the operating frequency block when tested to the temperature and supply voltage variations specified in RSS-Gen.

Complies?	Yes
-----------	-----

Appendix 8

External photos

Front side:



Back side:



Left side:



Right side:



Top side:



Bottom side:



Product Label:

