



Product Service

**Choose certainty.
Add value.**

Report On

FCC and Industry Canada Testing of the
Ericsson AB RRUS 11 B5 / KRC 161 285/2

COMMERCIAL-IN-CONFIDENCE

FCC ID: TA8AKRC161285-2

IC ID: 287AB-AS1612852

Document 75923458 Report 02 Issue 1

September 2013



Product Service

TÜV SÜD Product Service, Octagon House, Concorde Way, Segensworth North,
Fareham, Hampshire, United Kingdom, PO15 5RL
Tel: +44 (0) 1489 558100. Website: www.tuv-sud.co.uk

COMMERCIAL-IN-CONFIDENCE

REPORT ON

FCC and Industry Canada Testing of the
Ericsson RRUS 11 B5 / KRC 161 285/2

Document 75923458 Report 02 Issue 1

September 2013

PREPARED FOR

Ericsson AB
Isafjordsgatan 10
SE-164 80
Stockholm
Sweden

PREPARED BY

G Zhao
Test Engineer

APPROVED BY

N Forsyth
Authorised Signatory

DATED

27 September 2013

ENGINEERING STATEMENT

The measurements shown in this report were made in accordance with the procedures described on test pages. All reported testing was carried out on a sample equipment to demonstrate compliance with FCC CFR 47: Part 22 and Industry Canada RSS-132. The sample tested was found to comply with the requirements defined in the applied rules.

Test Engineer(s);

G Zhao

X Zhang





CONTENTS

Section	Page No
1	REPORT SUMMARY 3
1.1	Introduction 4
1.2	Brief Summary of Results 5
1.3	Declaration of Build Status 9
1.4	Product Information 10
1.5	Test Conditions 16
1.6	Deviations From the Standard 16
1.7	Modification Record 16
1.8	Alternative Test Site 16
2	TEST DETAILS 17
2.1	Maximum Peak Output Power - Conducted 18
2.2	Peak – average ratio 23
2.3	Modulation Characteristics 34
2.4	Occupied Bandwidth 37
2.5	Spurious Emissions at Antenna Terminals (± 1 MHz) 46
2.6	Radiated Spurious Emissions 70
2.7	Conducted Spurious Emissions 76
2.8	Receiver Spurious Emissions 97
3	TEST EQUIPMENT USED 102
3.1	Test Equipment Used 103
3.2	Measurement Uncertainty 104
4	ACCREDITATION, DISCLAIMERS AND COPYRIGHT 105
4.1	Accreditation, Disclaimers and Copyright 106



SECTION 1

REPORT SUMMARY

FCC and Industry Canada Testing of the
Ericsson RRUS 11 B5 / KRC 161 285/2



1.1 INTRODUCTION

The information contained in this report is intended to show verification of the Ericsson RRUS 11 B5 / KRC 161 285/2 to the requirements of FCC CFR 47 Part 22 and Industry Canada RSS-132.

Testing was carried out in support of a C2PC application for Grant of RRUS 11 B5 / KRC 161 285/2 for hardware update in LTE mode. The manufacturer has declared that this hardware update does not affect the frequency stability, therefore this requirement was not tested.

Objective	To perform FCC and Industry Canada Testing to determine the Equipment Under Test's (EUT's) compliance with the Test Specification, for the series of tests carried out.
Manufacturer	Ericsson AB
Product Name	RRUS 11 B5
Part Number	KRC 161 285/2
IC Model Number	AS1612852
Serial Number(s)	CB4P587217 CB4P587219
LTE Software Version	CXP102051/16 Rev R32BD
PIS Software Version	CXP9017316/1 Rev R39UL
Hardware Version	R2B
Number of Samples Tested	2
Test Specification/Issue/Date	FCC CFR 47 Part 22: 2012 Industry Canada RSS-132 issue 3: 2013
Incoming Release Date	Declaration of Build Status 11 July 2013
Order Number Date	PTP 26 June 2013
Start of Test	11 July 2013
Finish of Test	14 August 2013
Name of Engineer(s)	G Zhao X Zhang
Related Document(s)	ANSI C63.4: 2009 FCC CFR 47 Part 2: 2012 Industry Canada RSS-GEN Issue 3: 2010



1.2 BRIEF SUMMARY OF RESULTS

A brief summary of results in accordance with FCC CFR 47 Part 22 and Industry Canada RSS-132, is shown below.

Configuration 1 – Remote Radio Equipment							
Section	Spec Clause		Test Description	Mode	Mod State	Result	Comments
	FCC Part 2 and 22	RSS-132 and RSS-GEN					
	22.913 (a)	5.4	Effective Radiated Power	869.7MHz (1.4MHz OBW) / 879.0MHz (20.0MHz OBW)		N/A	No integral antenna.
				881.5MHz (1.4MHz, 3.0MHz, 5.0MHz, 10.0MHz, 15.0MHz, 20.0MHz OBW)		N/A	
				893.3MHz (1.4MHz OBW) / 884.0MHz (20.0MHz OBW)		N/A	
				869.7MHz + 888.3MHz (1.4MHz OBW) / 874.0MHz + 884.0MHz (10MHz OBW)		N/A	
				872.2MHz + 890.8MHz (1.4MHz OBW) / 876.5MHz + 886.5MHz (10MHz OBW)		N/A	
				893.3MHz + 874.7MHz (1.4MHz OBW) / 889.0MHz + 879.0MHz (10MHz OBW)		N/A	
2.1	2.1046, 22.913 (a)	5.4	Maximum Peak Output Power - Conducted	869.7MHz (1.4MHz OBW) / 879.0MHz (20.0MHz OBW)	0	Pass	-
				881.5MHz (1.4MHz, 3.0MHz, 5.0MHz, 10.0MHz, 15.0MHz, 20.0MHz OBW)	0	Pass	
				893.3MHz (1.4MHz OBW) / 884.0MHz (20.0MHz OBW)	0	Pass	
				869.7MHz + 888.3MHz (1.4MHz OBW) / 874.0MHz + 884.0MHz (10MHz OBW)	0	Pass	
				872.2MHz + 890.8MHz (1.4MHz OBW) / 873.0MHz + 890.0MHz (3.0MHz OBW) / 874.0MHz + 889.0MHz (5.0MHz OBW) / 876.5MHz + 886.5MHz (10MHz OBW)	0	Pass	
				893.3MHz + 874.7MHz (1.4MHz OBW) / 889.0MHz + 879.0MHz (10MHz OBW)	0	Pass	



Configuration 1 – Remote Radio Equipment							
Section	Spec Clause		Test Description	Mode	Mod State	Result	Comments
	FCC Part 2 and 22	RSS-132 and RSS-GEN					
2.2	22.913 (a)	5.4	Peak – Average Ratio	869.7MHz (1.4MHz OBW) / 879.0MHz (20.0MHz OBW)	0	Pass	-
				881.5MHz (1.4MHz, 3.0MHz, 5.0MHz, 10.0MHz, 15.0MHz, 20.0MHz OBW)	0	Pass	
				893.3MHz (1.4MHz OBW) / 884.0MHz (20.0MHz OBW)	0	Pass	
				869.7MHz + 888.3MHz (1.4MHz OBW) / 874.0MHz + 884.0MHz (10MHz OBW)	0	Pass	
				872.2MHz + 890.8MHz (1.4MHz OBW) / 873.0MHz + 890.0MHz (3.0MHz OBW) / 874.0MHz + 889.0MHz (5.0MHz OBW) / 876.5MHz + 886.5MHz (10MHz OBW)	0	Pass	
				893.3MHz + 874.7MHz (1.4MHz OBW) / 889.0MHz + 879.0MHz (10MHz OBW)	0	Pass	
2.3	2.1047 (d)	5.2	Modulation Characteristics	870.5MHz (3.0MHz OBW)		N/A	-
				881.5MHz (3.0MHz OBW)	0	Pass	
				892.5MHz (3.0MHz OBW)		N/A	
				869.7MHz + 888.3MHz (1.4MHz OBW) / 874.0MHz + 884.0MHz (10MHz OBW)		N/A	
				872.2MHz + 890.8MHz (1.4MHz OBW) / 876.5MHz + 886.5MHz (10MHz OBW)		N/A	
				893.3MHz + 874.7MHz (1.4MHz OBW) / 889.0MHz + 879.0MHz (10MHz OBW)		N/A	
2.4	2.1049, 22.917 (b)	RSS-Gen 4.6.1	Occupied Bandwidth	869.7MHz (1.4MHz OBW) / 879.0MHz (20.0MHz OBW)	0	Pass	-
				881.5MHz (1.4MHz, 3.0MHz, 5.0MHz, 10.0MHz, 15.0MHz, 20.0MHz OBW)	0	Pass	
				893.3MHz (1.4MHz OBW) / 884.0MHz (20.0MHz OBW)	0	Pass	
				869.7MHz + 888.3MHz (1.4MHz OBW) / 874.0MHz + 884.0MHz (10MHz OBW)		N/A	
				872.2MHz + 890.8MHz (1.4MHz OBW) / 876.5MHz + 886.5MHz (10MHz OBW)		N/A	
				893.3MHz + 874.7MHz (1.4MHz OBW) / 889.0MHz + 879.0MHz (10MHz OBW)		N/A	



Configuration 1 – Remote Radio Equipment							
Section	Spec Clause		Test Description	Mode	Mod State	Result	Comments
	FCC Part 2 and 22	RSS-132 and RSS-GEN					
2.5	2.1051, 22.917 (b)	5.5	Spurious Emissions at Antenna Terminals (± 1 MHz)	869.7MHz (1.4MHz OBW) / 870.5MHz (3.0MHz OBW) 871.5MHz (5.0MHz OBW) / 874.0MHz (10.0MHz OBW) 876.5MHz (15.0MHz OBW) / 879.0MHz (20.0MHz OBW)	0	Pass	-
				881.5MHz		N/A	
				893.3MHz (1.4MHz OBW) / 892.5MHz (3.0MHz OBW) 891.5MHz (5.0MHz OBW) / 889.0MHz (10.0MHz OBW) 886.5MHz (15.0MHz OBW) / 884.0MHz (20.0MHz OBW)	0	Pass	
				869.7MHz + 871.1MHz (1.4MHz OBW) / 870.5MHz + 873.5MHz (3MHz OBW) / 871.5MHz + 876.5MHz (5MHz OBW) / 874.0MHz + 884.0MHz (10MHz OBW)	0	Pass	
				-		N/A	
				893.3MHz + 891.9MHz (1.4MHz OBW) / 892.5MHz + 889.5MHz (3MHz OBW) / 891.5MHz + 886.5MHz (5MHz OBW) / 889.0MHz + 879.0MHz (10MHz OBW)	0	Pass	
2.6	2.1053, 22.917 (a)	5.5	Radiated Spurious Emissions	869.7MHz (1.4MHz OBW)	0	Pass	-
				881.5MHz (1.4MHz, 3.0MHz, 5.0MHz, 10.0MHz, 15MHz, 20.0MHz OBW)	0	Pass	
				893.3MHz (1.4MHz OBW)	0	Pass	
				869.7MHz + 888.3MHz (1.4MHz OBW)		N/A	
				872.2MHz + 890.8MHz (1.4MHz OBW)	0	Pass	
				893.3MHz + 874.7MHz (1.4MHz OBW)		N/A	
2.7	2.1051, 22.917 (a)	5.5	Conducted Spurious Emissions	869.7MHz (1.4MHz OBW) / 879.0MHz (20.0MHz OBW)	0	Pass	-
				881.5MHz (1.4MHz, 20.0MHz OBW)	0	Pass	
				893.3MHz (1.4MHz OBW) / 884.0MHz (20.0MHz OBW)	0	Pass	
				869.7MHz + 888.3MHz (1.4MHz OBW) / 874.0MHz + 884.0MHz (10MHz OBW)	0	Pass	
				872.2MHz + 890.8MHz (1.4MHz OBW) / 876.5MHz + 886.5MHz (10MHz OBW)	0	Pass	
				893.3MHz + 874.7MHz (1.4MHz OBW) / 889.0MHz + 879.0MHz (10MHz OBW)	0	Pass	



Configuration 1 – Remote Radio Equipment							
Section	Spec Clause		Test Description	Mode	Mod State	Result	Comments
	FCC Part 2 and 22	RSS-132 and RSS-GEN					
	2.1055, 22.355	5.3	Frequency Stability Under Temperature Variations	870.5MHz (3.0MHz OBW)		N/A	-
				881.5MHz (3.0MHz OBW)		N/A	
				892.5MHz (3.0MHz OBW)		N/A	
				869.7MHz + 888.3MHz (1.4MHz OBW) / 874.0MHz + 884.0MHz (10MHz OBW)		N/A	
				872.2MHz + 890.8MHz (1.4MHz OBW) / 876.5MHz + 886.5MHz (10MHz OBW)		N/A	
				893.3MHz + 874.7MHz (1.4MHz OBW) / 889.0MHz + 879.0MHz (10MHz OBW)		N/A	
	2.1055, 22.355	5.3	Frequency Stability Under Voltage Variations	870.5MHz (3.0MHz OBW)		N/A	-
				881.5MHz (3.0MHz OBW)		N/A	
				892.5MHz (3.0MHz OBW)		N/A	
				869.7MHz + 888.3MHz (1.4MHz OBW) / 874.0MHz + 884.0MHz (10MHz OBW)		N/A	
				872.2MHz + 890.8MHz (1.4MHz OBW) / 876.5MHz + 886.5MHz (10MHz OBW)		N/A	
				893.3MHz + 874.7MHz (1.4MHz OBW) / 889.0MHz + 879.0MHz (10MHz OBW)		N/A	

Section	Spec Clause		Test Description	Mode	Mod State	Result	Comments
	FCC Part 15						
2.8	15.111		Receiver Spurious Emissions	881.5MHz (1.4MHz OBW)	0	Pass	This test is shown for information only.
				872.2MHz + 890.8MHz (1.4MHz OBW)	0	Pass	

N/A – Not Applicable



1.3 DECLARATION OF BUILD STATUS

MAIN EUT	
MANUFACTURING DESCRIPTION	Remote Radio Equipment
MANUFACTURER	Ericsson AB
PRODUCT NAME	RRUS 11 B5
PART NUMBER	KRC 161 285/2
IC Model Number	AS1612852
SERIAL NUMBER	CB4P587217 CB4P587219
HARDWARE VERSION	R2B
LTE SOFTWARE	CXP102051/16 Rev R32BD
PIS SOFTWARE	CXP9017316/1 Rev R39UL
TRANSMITTER OPERATING RANGE	TX: 869MHz - 894MHz RX: 824MHz - 849MHz
MODULATIONS	QPSK, 16QAM, 64QAM
NUMBER OF CARRIERS	Maximum 2 carriers
ITU DESIGNATION OF EMISSION	1M40F9W, 3M00F9W, 5M00F9W, 10M0F9W, 15M0F9W, 20M0F9W
OUTPUT POWER (RMS) (W or dBm)	Single Carrier: 1x 46dBm per port (1 x 40W per port) Multi Carrier(x 2): 2 x 43dBm per port (2 x 20W per port)
OUTPUT POWER TOLERANCE	± 1.0dB
INSTANTANEOUS BANDWIDTH	20MHz
CHANNEL BANDWIDTH	Single carrier supports 1.4MHz, 3MHz, 5MHz, 10MHz, 15MHz and 20MHz Multi carrier supports 1.4MHz, 3MHz, 5MHz and 10MHz according to 3GPP TS 36.141
ANTENNA	No dedicated antenna, handled during licensing
NUMBER OF ANTENNA PORTS	2 TX/RX ports
FCC ID	TA8AKRC161285-2
IC ID	287AB-AS1612852
TECHNICAL DESCRIPTION (a brief description of the intended use and operation)	The equipment is the Radio Part of LTE Base Station.

Signature

Date

08 August 2013

D of B S Serial No

75923458/02

No responsibility will be accepted by TÜV SÜD Product Service as to the accuracy of the information declared in this document by the manufacturer.



1.4 PRODUCT INFORMATION

1.4.1 Technical Description

The Equipment Under Test (EUT) RRUS 11 B5 / KRC 161 285/2 is an Ericsson Radio Equipment working in the public mobile service 850MHz band which operates in LTE mode. The RRUS 11 B5 / KRC 161 285/2 operates from a -48V DC supply.

The Equipment Under Test (EUT) is shown in the photograph below. A full technical description can be found in the Manufacturers documentation.



Equipment Under Test



Product Service

1.4.2 Test Configuration

Configuration 1: Radio Equipment

The EUT was configured in accordance with FCC CFR 47 Part 22 and Industry Canada RSS-132.

The RRUS 11 B5 / KRC 161 285/2 supports Test Models E-TM1.1, E-TM3.2 and E-TM3.1 at 850MHz defined in 3GPP TS 36.141. Test Model E-TM1.1 is used to represent QPSK modulation only, Test Model E-TM3.2 is used to represent 16QAM modulation, and Test Model E-TM3.1 is used to represent 64QAM modulation.

The EUT includes two TX/RX ports and it can be configured to transmit in MIMO mode, and MIMO mode was used for measurements as the worst configuration.

The Maximum Output Power was tested on both TX/RX output connector RF A and RF B, all other TX measurements were performed on the combined TX/RX output connector RF A of the EUT as the representative port. RX testing was performed on the antenna connector RF B of the EUT.

The complete testing was performed with the EUT transmitting at maximum RF power unless otherwise stated.

The settings below were found to be representative for all traffic scenarios when several settings with the different modulations, channel bandwidths were tested to find the worst case setting. These settings were used for all measurements if not otherwise noted:

- Single Carrier: Test Model E-TM1.1 in channel bandwidth 1.4MHz and 20MHz.
- Multi Carrier (x2): Test Model E-TM1.1 in channel bandwidth 1.4MHz and 10MHz.

The EUT was powered by a -48V DC Power supply.



Test Setup, Conducted Measurement:

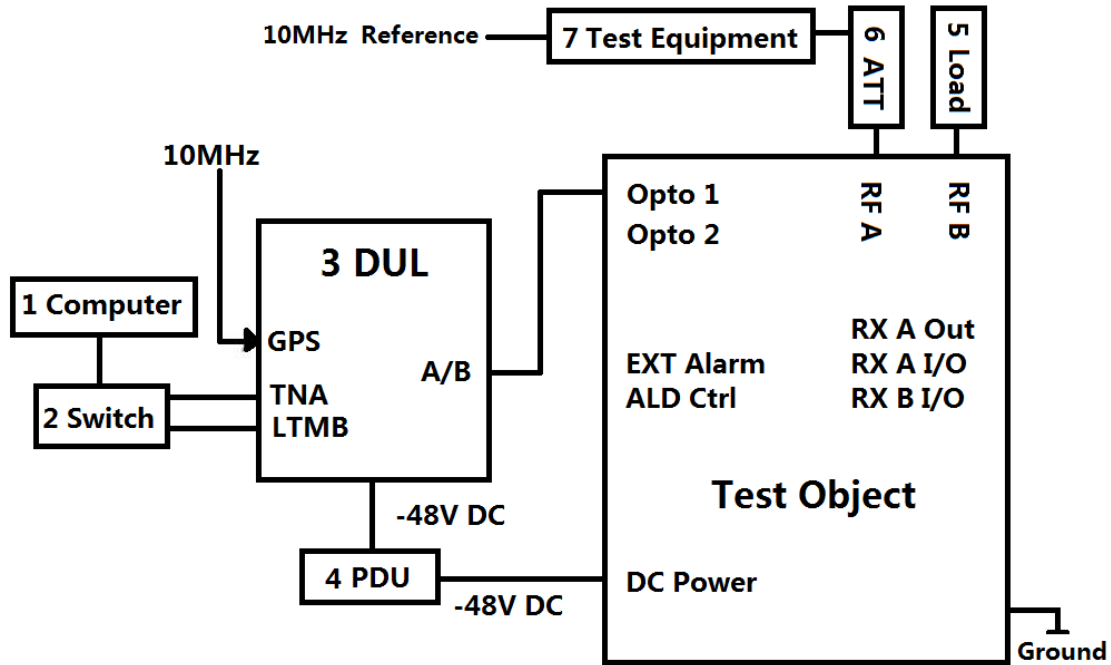

Product Name	Product Number	Version	Serial Number
RRUS 11 B5	KRC 161 285/2	R2B	CB4P587217

No.	Auxiliary Equipment	Part Number / Model Type	Version	Serial Number
1	Computer	HP EliteBook 8460p	--	AP523464
2	Switch	TL-SF1008+	--	11936826484
3	RBS 6601	BFL 901 009/1	--	--
	DUL 20 01	KDU 137 533/4	R1C	CB4H365213
	SUP 6601	1/BFL 901 009/1	R3B	BR81262578
4	Power Supply	DH1716-5D	--	2008040041
	Power Supply	DH1716-5D	--	2008040050
5	Load	TF100	--	09121648
6	40dB Attenuator	48-40-43-LIM	--	BR5020
7	Power Meter	Rohde & Schwarz NRP2	--	101283
	Power Sensor	Rohde & Schwarz NRP-Z51	--	102312
	Spectrum Analyzer	FSQ26	--	200014
	Spectrum Analyzer	FSQ26	--	201122



Test Setup, Radiated Measurement:

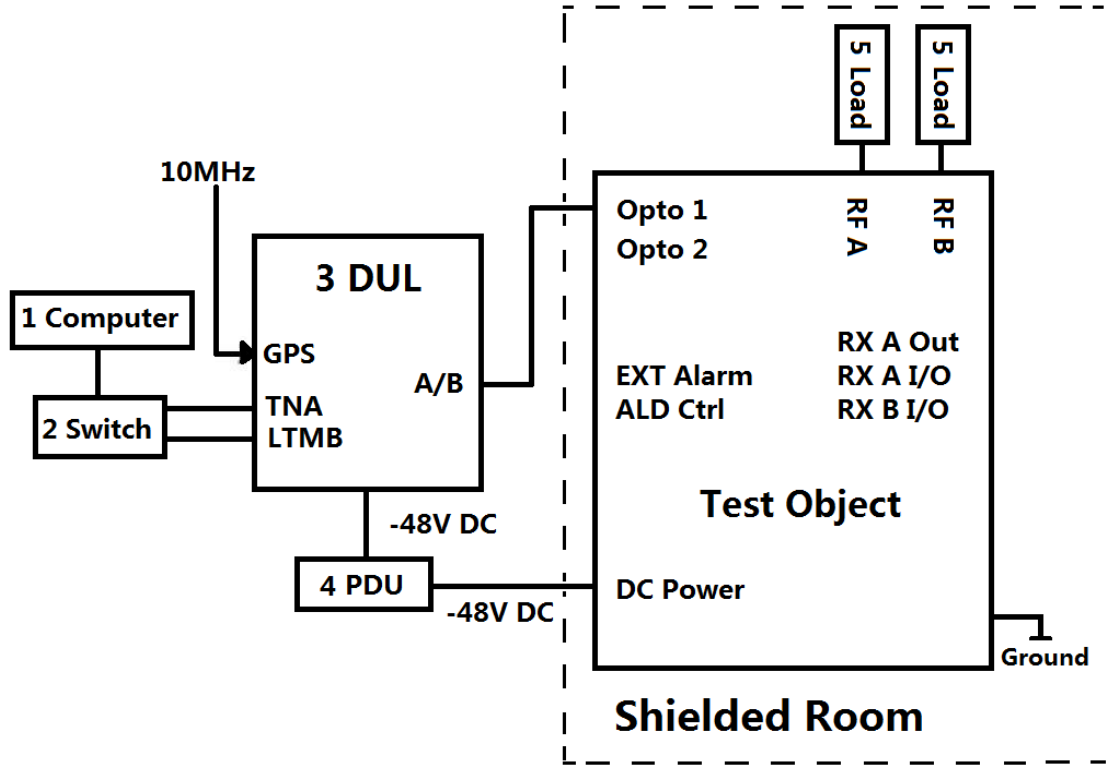

Product Name	Product Number	Version	Serial Number
RRUS 11 B5	KRC 161 285/2	R2B	CB4P587219

No.	Auxiliary Equipment	Part Number / Model Type	Version	Serial Number
1	Computer	HP EliteBook 8460p	--	AP523464
2	Switch	TL-SF1008+	--	11936826484
3	RBS 6601	BFL 901 009/1	--	--
	DUL 20 01	KDU 137 533/4	R1C	CB4H365213
	SUP 6601	1/BFL 901 009/1	R3B	BR81262578
4	Power Supply	DH1716-5D	--	2008040041
	Power Supply	DH1716-5D	--	2008040050
5	Load	TF100	--	09121648
	Load	TF100	--	09121605



1.4.3 Modes of Operation

Modes of operation of each EUT during testing were as follows:

Single Carrier :

Bottom Channel :

Mode 1 - 1.4 : EARFCN 2407: 869.7MHz (1.4MHz Bandwidth)

Mode 1 - 3 : EARFCN 2415: 870.5MHz (3.0MHz Bandwidth)

Mode 1 - 5 : EARFCN 2425: 871.5MHz (5.0MHz Bandwidth)

Mode 1 - 10 : EARFCN 2450: 874.0MHz (10.0MHz Bandwidth)

Mode 1 - 15 : EARFCN 2475: 876.5MHz (15.0MHz Bandwidth)

Mode 1 - 20 : EARFCN 2500: 879.0MHz (20.0MHz Bandwidth)

Middle Channel :

Mode 2 : EARFCN 2525: 881.5MHz

Top Channel :

Mode 3 - 1.4 : EARFCN 2643: 893.3MHz (1.4MHz Bandwidth)

Mode 3 - 3 : EARFCN 2635: 892.5MHz (3.0MHz Bandwidth)

Mode 3 - 5 : EARFCN 2625: 891.5MHz (5.0MHz Bandwidth)

Mode 3 - 10 : EARFCN 2600: 889.0MHz (10.0MHz Bandwidth)

Mode 3 - 15 : EARFCN 2575: 886.5MHz (15.0MHz Bandwidth)

Mode 3 - 20 : EARFCN 2550: 884.0MHz (20.0MHz Bandwidth)

**Multi Carrier (x2):**

Bottom Channel :

- Mode 4 - 1.4 : EARFCN 2407 + 2593: 869.7MHz + 888.3MHz (1.4MHz Bandwidth)
- Mode 4 - 3 : EARFCN 2415 + 2585: 870.5MHz + 887.5MHz (3.0MHz Bandwidth)
- Mode 4 - 5 : EARFCN 2425 + 2575: 871.5MHz + 886.5MHz (5.0MHz Bandwidth)
- Mode 4 - 10 : EARFCN 2450 + 2550: 874.0MHz + 884.0MHz (10.0MHz Bandwidth)

- Mode 4' - 1.4 : EARFCN 2407 + 2421: 869.7MHz + 871.1MHz (1.4MHz Bandwidth)
- Mode 4' - 3 : EARFCN 2415 + 2445: 870.5MHz + 873.5MHz (3.0MHz Bandwidth)
- Mode 4' - 5 : EARFCN 2425 + 2475: 871.5MHz + 876.5MHz (5.0MHz Bandwidth)

Middle Channel :

- Mode 5 - 1.4 : EARFCN 2432 + 2618: 872.2MHz + 890.8MHz (1.4MHz Bandwidth)
- Mode 5 - 3 : EARFCN 2440 + 2610: 873.0MHz + 890.0MHz (3.0MHz Bandwidth)
- Mode 5 - 5 : EARFCN 2450 + 2600: 874.0MHz + 889.0MHz (5.0MHz Bandwidth)
- Mode 5 - 10 : EARFCN 2475 + 2575: 876.5MHz + 886.5MHz (10.0MHz Bandwidth)

Top Channel :

- Mode 6 - 1.4 : EARFCN 2643 + 2457: 893.3MHz + 874.7MHz (1.4MHz Bandwidth)
- Mode 6 - 3 : EARFCN 2635 + 2465: 892.5MHz + 875.5MHz (3.0MHz Bandwidth)
- Mode 6 - 5 : EARFCN 2625 + 2475: 891.5MHz + 876.5MHz (5.0MHz Bandwidth)
- Mode 6 - 10 : EARFCN 2600 + 2500: 889.0MHz + 879.0MHz (10.0MHz Bandwidth)

- Mode 6' - 1.4 : EARFCN 2643 + 2629: 893.3MHz + 891.9MHz (1.4MHz Bandwidth)
- Mode 6' - 3 : EARFCN 2635 + 2605: 892.5MHz + 889.5MHz (3.0MHz Bandwidth)
- Mode 6' - 5 : EARFCN 2625 + 2575: 891.5MHz + 886.5MHz (5.0MHz Bandwidth)

Information on the specific test modes utilised are detailed in the test procedure for each individual test.



Product Service

1.5 TEST CONDITIONS

For all tests the EUT was set up in accordance with the relevant test standard and to represent typical operating conditions. Tests were applied with the EUT situated in a shielded enclosure, test laboratories or an open test area as appropriate.

The EUT was powered from a -48V DC supply.

1.6 DEVIATIONS FROM THE STANDARD

No deviations from the applicable test standards or test plan were made during testing.

1.7 MODIFICATION RECORD

Mod State 0 - No modifications were made to the EUT during testing.

1.8 ALTERNATIVE TEST SITE

Only Radiated Spurious Emissions testing has been performed under the following site registrations:

FCC Accreditation 910917:

The State Radio Monitoring Centre, No.80 Beilishi Road Xicheng District Beijing, China.

Industry Canada Accreditation 7308A-1:

The State Radio Monitoring Centre, No.80 Beilishi Road Xicheng District Beijing, China.



Product Service

SECTION 2

TEST DETAILS

FCC and Industry Canada Testing of the
Ericsson RRUS 11 B5 / KRC 161 285/2



2.1 MAXIMUM PEAK OUTPUT POWER - CONDUCTED

2.1.1 Specification Reference

FCC CFR 47 Part 2, Clause 2.1046
 FCC CFR 47 Part 22, Clause 22.913 (a)
 Industry Canada RSS-132, Clause 5.4

2.1.2 Equipment Under Test

RRUS 11 B5 / KRC 161 285/2, S/N: CB4P587217

2.1.3 Date of Test and Modification State

11, 15 and 16 July 2013 – Modification State 0

2.1.4 Test Equipment Used

The major items of test equipment used for the above tests are identified in Section 3.1.

2.1.5 Test Method and Operating Modes

The test was applied in accordance with the test method requirements of FCC CFR 47 Part 2 and Part 22 and Industry Canada RSS-132.

Using a power meter and attenuator(s), the output power of the EUT was measured at the antenna terminal. The carrier power was measured with E-TM1.1, E-TM3.2 and E-TM3.1 test models.

Since when working in MIMO mode, the EUT transmits on two antennas simultaneously in the same frequency range, the output power at both antennas RF A and RF B were tested and the total power were then summed mathematically in linear power units by using the Measure and Sum approach.

The path loss was measured and entered to the power meter as a reference level offset to get the output power value directly.

The test was performed with the EUT in the following configurations and modes of operation:

Configuration 1 - Mode 1 - 1.4, Mode 1 - 20
 - Mode 2 (1.4MHz, 3.0MHz, 5.0MHz, 10.0MHz, 15.0MHz, 20.0MHz OBW)
 - Mode 3 - 1.4, Mode 3 - 20
 - Mode 4 - 1.4, Mode 4 - 10
 - Mode 5 - 1.4, Mode 5 - 3, Mode 5 - 5, Mode 5 - 10
 - Mode 6 - 1.4, Mode 6 - 10

2.1.6 Environmental Conditions

	11 July 2013	15 July 2013	16 July 2013
Ambient Temperature	22.0°C	23.0°C	22.5°C
Relative Humidity	61.0%	64.5%	60.0%



2.1.7 Test Results

For the period of test the EUT met the requirements of FCC CFR 47 Part 2 and Part 22 and Industry Canada RSS-132 for Maximum Peak Output Power.

The test results are shown below

Single Carrier

E-TM1.1: 1.4MHz Bandwidth

Configuration 1 - Mode 1 - 1.4, Mode 2 and Mode 3 - 1.4

EARFCN	Frequency (MHz)	RF A		RF B		*Total (dBm) RMS	*Total (W) RMS
		Result (dBm) RMS	Result (W) RMS	Result (dBm) RMS	Result (W) RMS		
2407 (Bottom)	869.7	45.58	36.14	45.63	36.56	48.62	72.70
2525 (Middle)	881.5	45.73	37.41	45.73	37.41	48.74	74.82
2643 (Top)	893.3	45.37	34.43	45.42	34.83	48.40	69.26

E-TM1.1: 20.0MHz Bandwidth

Configuration 1 - Mode 1 - 20, Mode 2 and Mode 3 - 20

EARFCN	Frequency (MHz)	RF A		RF B		*Total (dBm) RMS	*Total (W) RMS
		Result (dBm) RMS	Result (W) RMS	Result (dBm) RMS	Result (W) RMS		
2500 (Bottom)	879.0	45.81	38.11	45.89	38.82	48.86	76.93
2525 (Middle)	881.5	45.78	37.84	45.86	38.55	48.83	76.39
2550 (Top)	884.0	45.81	38.11	45.87	38.64	48.85	76.75

E-TM1.1: 3.0MHz, 5.0MHz, 10.0MHz and 15.0MHz Bandwidth

Configuration 1 - Mode 2

EARFCN / Frequency (MHz)	BW Config (MHz)	RF A		RF B		*Total (dBm) RMS	*Total (W) RMS
		Result (dBm) RMS	Result (W) RMS	Result (dBm) RMS	Result (W) RMS		
2525 (Middle) / 881.5	3.0	45.82	38.19	45.85	38.46	48.85	76.65
	5.0	45.82	38.19	45.87	38.64	48.86	76.83
	10.0	45.80	38.02	45.88	38.73	48.85	76.75
	15.0	45.76	37.67	45.83	38.28	48.81	75.95



Product Service

E-TM3.2 and E-TM3.1: 1.4MHz Bandwidth

Configuration 1 - Mode 2

EARFCN / Frequency (MHz)	Test Model	RF A		RF B		*Total (dBm) RMS	*Total (W) RMS
		Result (dBm) RMS	Result (W) RMS	Result (dBm) RMS	Result (W) RMS		
2525 (Middle) / 881.5	E-TM3.2	45.74	37.50	45.77	37.76	48.77	75.26
	E-TM3.1	45.69	37.07	45.77	37.76	48.74	74.83

E-TM3.2 and E-TM3.1: 20.0MHz Bandwidth

Configuration 1 - Mode 2

EARFCN / Frequency (MHz)	Test Model	RF A		RF B		*Total (dBm) RMS	*Total (W) RMS
		Result (dBm) RMS	Result (W) RMS	Result (dBm) RMS	Result (W) RMS		
2525 (Middle) / 881.5	E-TM3.2	45.71	37.24	45.82	38.19	48.78	75.43
	E-TM3.1	45.74	37.50	45.82	38.19	48.79	75.69

**Multi Carrier (x2)****E-TM1.1: 1.4MHz Bandwidth**Configuration 1 - Mode 4 - 1.4, Mode 5 - 1.4 and Mode 6 - 1.4

EARFCN	Frequency (MHz)	RF A		RF B		*Total (dBm) RMS	*Total (W) RMS
		Result (dBm) RMS	Result (W) RMS	Result (dBm) RMS	Result (W) RMS		
2407 + 2593 (Bottom)	869.7 + 888.3	45.07	32.14	45.16	32.81	48.13	64.95
2432 + 2618 (Middle)	872.2 + 890.8	45.07	32.14	45.21	33.19	48.15	65.33
2643 + 2457 (Top)	893.3 + 874.7	45.03	31.84	45.06	32.06	48.06	63.90

E-TM1.1: 10.0MHz BandwidthConfiguration 1 - Mode 4 - 10, Mode 5 - 10 and Mode 6 - 10

EARFCN	Frequency (MHz)	RF A		RF B		*Total (dBm) RMS	*Total (W) RMS
		Result (dBm) RMS	Result (W) RMS	Result (dBm) RMS	Result (W) RMS		
2450 + 2550 (Bottom)	874.0 + 884.0	45.82	38.19	45.89	38.82	48.87	77.01
2475 + 2575 (Middle)	876.5 + 886.5	45.79	37.93	45.87	38.64	48.84	76.57
2600 + 2500 (Top)	889.0 + 879.0	45.79	37.93	45.84	38.37	48.83	76.30

E-TM1.1: 3.0MHz and 5.0MHz BandwidthConfiguration 1 - Mode 5 - 3 and Mode 5 - 5

EARFCN / Frequency (MHz)	BW Config (MHz)	RF A		RF B		*Total (dBm) RMS	*Total (W) RMS
		Result (dBm) RMS	Result (W) RMS	Result (dBm) RMS	Result (W) RMS		
2440 + 2610 / 873.0 + 890.0 (Middle)	3.0	45.16	32.81	45.27	33.65	48.23	66.46
2450 + 2600 / 874.0 + 889.0 (Middle)	5.0	45.19	33.04	45.29	33.81	48.25	66.85

**E-TM3.2 and E-TM3.1: 1.4MHz Bandwidth****Configuration 1 - Mode 5 - 1.4**

EARFCN / Frequency (MHz)	Test Model	RF A		RF B		*Total (dBm) RMS	*Total (W) RMS
		Result (dBm) RMS	Result (W) RMS	Result (dBm) RMS	Result (W) RMS		
2432 + 2618 / 872.2 + 890.8 (Middle)	E-TM3.2	45.03	31.84	45.14	32.66	48.10	64.50
	E-TM3.1	45.01	31.70	45.12	32.51	48.08	64.21

E-TM3.2 and E-TM3.1: 10.0MHz Bandwidth**Configuration 1 - Mode 5 - 10**

EARFCN / Frequency (MHz)	Test Model	RF A		RF B		*Total (dBm) RMS	*Total (W) RMS
		Result (dBm) RMS	Result (W) RMS	Result (dBm) RMS	Result (W) RMS		
2475 + 2575 / 876.5 + 886.5 (Middle)	E-TM3.2	45.74	37.50	45.85	38.46	48.81	75.96
	E-TM3.1	45.78	37.84	45.84	38.37	48.82	76.21

Note *:

Two transmitters output power were summed up according to FCC KDB662911 D01 for MIMO mode.

This unit is tested without antenna. ERP/EIRP compliance is addressed at the time of licensing, as required by the responsible FCC/IC Bureau(s). Licensee's are the required to take into account maximum allowed antenna gain used in combination with above power settings to prevent the radiated output power to exceed the limits.

Limit	≤820W or ≤+59.1dBm
-------	--------------------

Remarks

The EUT does not exceed 820W or 59.1dBm at the measured frequencies.



Product Service

2.2 PEAK – AVERAGE RATIO

2.2.1 Specification Reference

FCC CFR 47 Part 22, Clause 22.913 (a)
Industry Canada RSS-132, Clause 5.4

2.2.2 Equipment Under Test

RRUS 11 B5 / KRC 161 285/2, S/N: CB4P587217

2.2.3 Date of Test and Modification State

11, 15 and 16 July 2013 – Modification State 0

2.2.4 Test Equipment Used

The major items of test equipment used for the above tests are identified in Section 3.1.

2.2.5 Test Method and Operating Modes

The test was applied in accordance with the test method requirements of FCC CFR 47 Part 22 and Industry Canada RSS-132.

A peak to average ratio measurement is performed at the conducted port of the EUT. The spectrum analyzers Complementary Cumulative Distribution Function (CCDF) measurement profile is used to determine the largest deviation between the average and the peak power of the EUT in given bandwidth. The CCDF curve shows how much time the peak waveform spends at or above a given average power level. The percent of time the signal spends at or above the level defines the probability for that particular power level.

The measurements were performed on the combined output connector RF A. Limited complementary measurement were done at the output connector RF B to verify identical performance for both transmitter chains in MIMO mode.

The path loss measured and entered as a reference level offset.

The test was performed with the EUT in the following configurations and modes of operation:

Configuration 1 - Mode 1 - 1.4, Mode 1 - 20
 - Mode 2 (1.4MHz, 3.0MHz, 5.0MHz, 10.0MHz, 15.0MHz, 20.0MHz OBW)
 - Mode 3 - 1.4, Mode 3 - 20
 - Mode 4 - 1.4, Mode 4 - 10
 - Mode 5 - 1.4, Mode 5 - 3, Mode 5 - 5, Mode 5 - 10
 - Mode 6 - 1.4, Mode 6 - 10

2.2.6 Environmental Conditions

	11 July 2013	15 July 2013	16 July 2013
Ambient Temperature	22.0°C	23.0°C	22.5°C
Relative Humidity	61.0%	64.5%	60.0%



Product Service

2.2.7 Test Results

For the period of test the EUT met the requirements of FCC CFR 47 Part 22 and Industry Canada RSS-132 for Peak – Average Ratio.

The test results are shown below.

Single Carrier

Configuration 1 - Mode 1 - 1.4

E-TM1.1: 1.4MHz Bandwidth

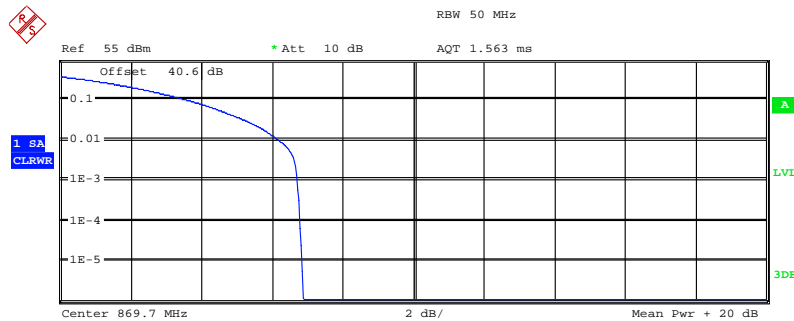

Complementary Cumulative Distribution Function
 NOF samples: 100000, Usable BW: 37.9MHz

Trace 1	
Mean	45.76 dBm
Peak	52.62 dBm
Crest	6.86 dB
10 %	3.59 dB
1 %	6.19 dB
.1 %	6.70 dB
.01 %	6.79 dB

Date: 11.JUL.2013 16:20:30



Configuration 1 - Mode 1 - 20

E-TM1.1: 20.0MHz Bandwidth

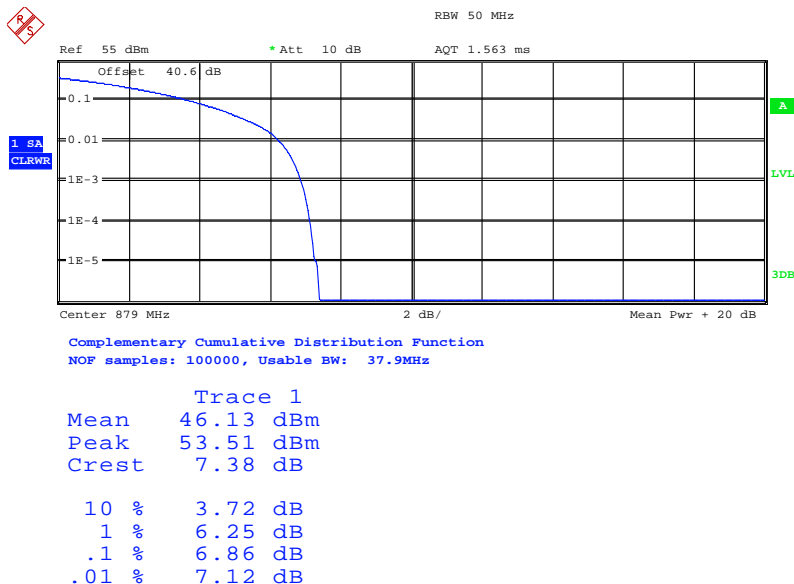

Date: 11.JUL.2013 16:41:42

Configuration 1 - Mode 2

E-TM1.1: 1.4MHz Bandwidth

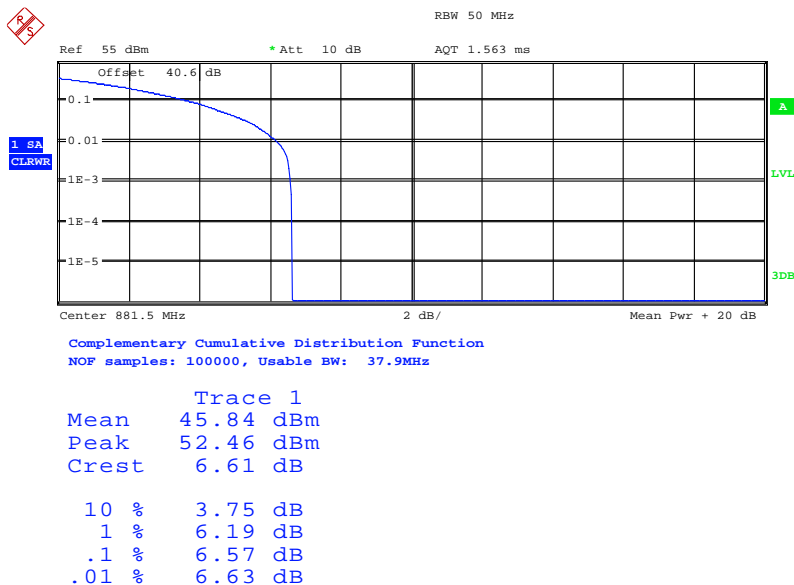

Date: 11.JUL.2013 09:46:02



Product Service

E-TM1.1: 3.0MHz Bandwidth

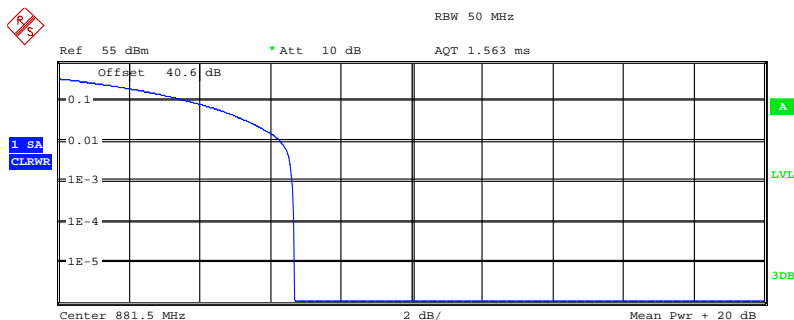

Complementary Cumulative Distribution Function
 NOF samples: 100000, Usable BW: 37.9MHz

Trace 1	
Mean	46.08 dBm
Peak	52.74 dBm
Crest	6.66 dB
10 %	3.75 dB
1 %	6.28 dB
.1 %	6.63 dB
.01 %	6.67 dB

Date: 11.JUL.2013 11:21:57

E-TM1.1: 5.0MHz Bandwidth

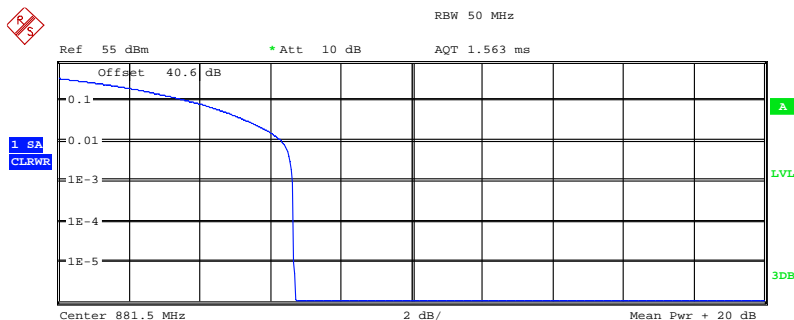

Complementary Cumulative Distribution Function
 NOF samples: 100000, Usable BW: 37.9MHz

Trace 1	
Mean	46.09 dBm
Peak	52.81 dBm
Crest	6.72 dB
10 %	3.75 dB
1 %	6.31 dB
.1 %	6.63 dB
.01 %	6.67 dB

Date: 11.JUL.2013 13:04:49



E-TM1.1: 10.0MHz Bandwidth

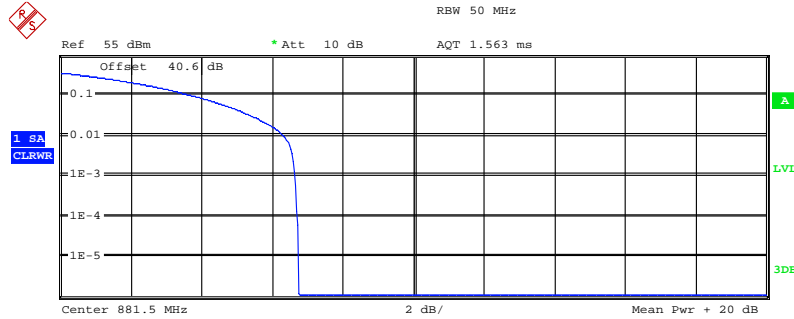

Center 881.5 MHz 2 dB/ Mean Pwr + 20 dB
 Complementary Cumulative Distribution Function
 NOF samples: 100000, Usable BW: 37.9MHz

Trace 1	
Mean	46.06 dBm
Peak	52.81 dBm
Crest	6.75 dB
10 %	3.72 dB
1 %	6.31 dB
.1 %	6.63 dB
.01 %	6.70 dB

Date: 11.JUL.2013 13:19:41

E-TM1.1: 15.0MHz Bandwidth

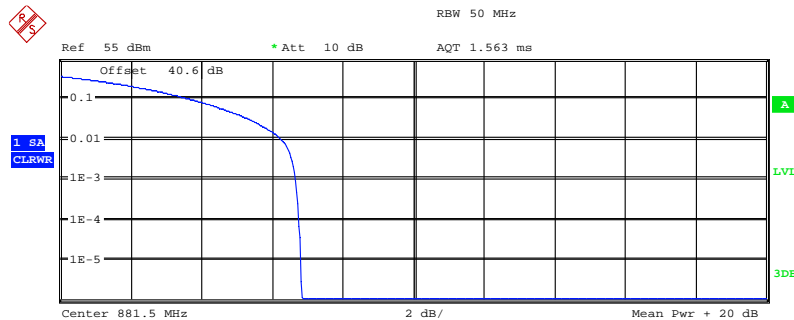

Center 881.5 MHz 2 dB/ Mean Pwr + 20 dB
 Complementary Cumulative Distribution Function
 NOF samples: 100000, Usable BW: 37.9MHz

Trace 1	
Mean	46.06 dBm
Peak	52.88 dBm
Crest	6.82 dB
10 %	3.72 dB
1 %	6.25 dB
.1 %	6.67 dB
.01 %	6.76 dB

Date: 11.JUL.2013 13:32:51



E-TM1.1: 20.0MHz Bandwidth

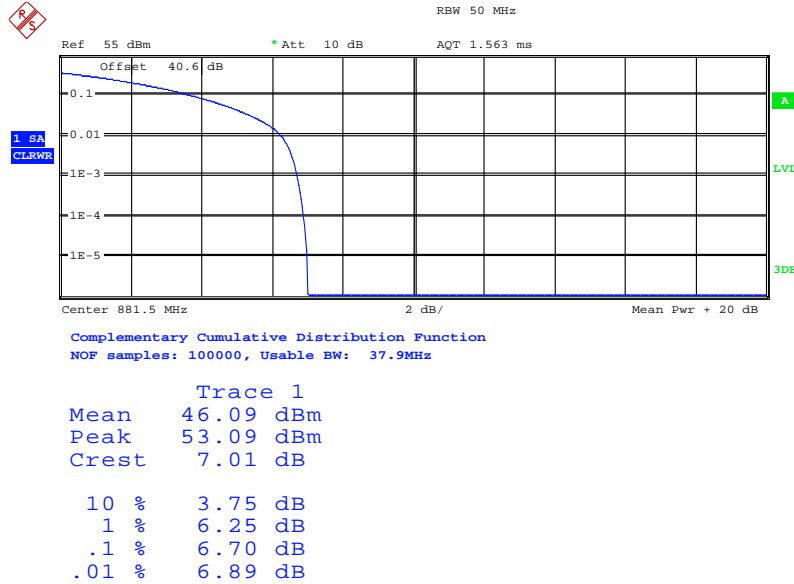

Date: 11.JUL.2013 11:01:27

Configuration 1 - Mode 3 - 1.4

E-TM1.1: 1.4MHz Bandwidth

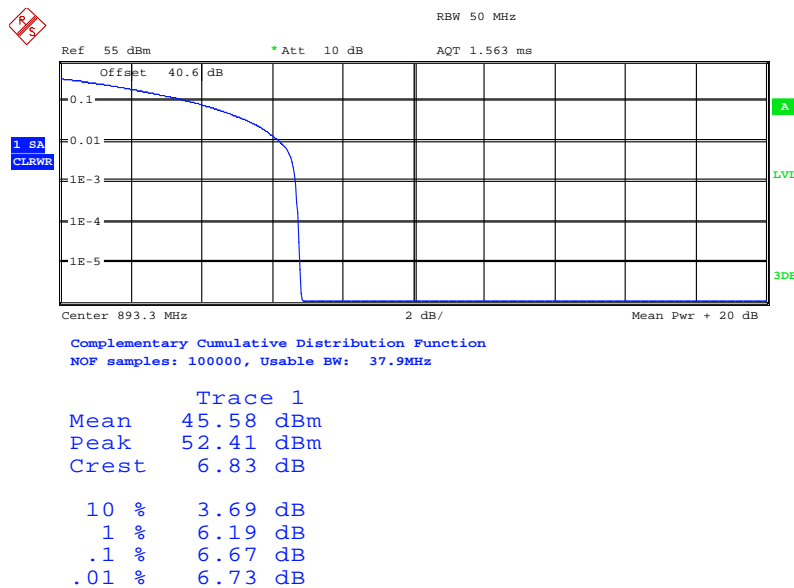

Date: 11.JUL.2013 15:59:14



Configuration 1 - Mode 3 - 20

E-TM1.1: 20.0MHz Bandwidth

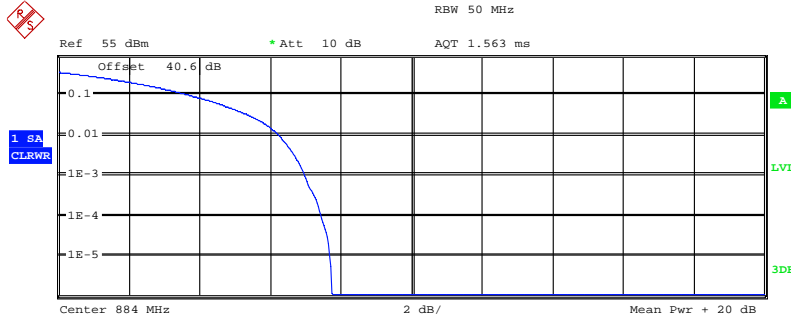

Complementary Cumulative Distribution Function
 NOF samples: 100000, Usable BW: 37.9MHz

Trace 1	
Mean	46.13 dBm
Peak	53.87 dBm
Crest	7.75 dB
10 %	3.72 dB
1 %	6.22 dB
.1 %	6.99 dB
.01 %	7.44 dB

Date: 11.JUL.2013 17:22:21

Multi Carrier (x2)

Configuration 1 - Mode 4 - 1.4

E-TM1.1: 1.4MHz Bandwidth

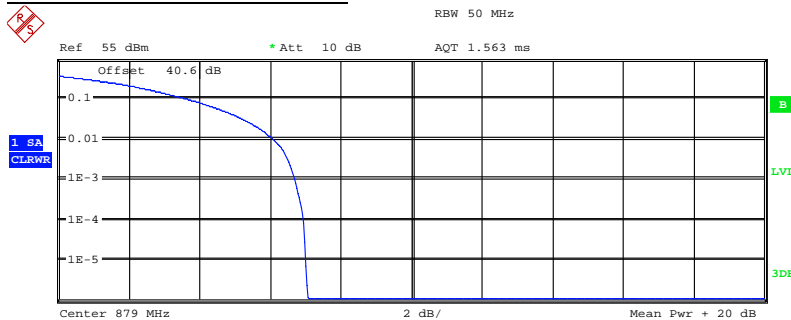

Complementary Cumulative Distribution Function
 NOF samples: 100000, Usable BW: 37.9MHz

Trace 1	
Mean	45.39 dBm
Peak	52.45 dBm
Crest	7.06 dB
10 %	3.69 dB
1 %	6.09 dB
.1 %	6.70 dB
.01 %	6.96 dB

Date: 16.JUL.2013 11:18:00



Configuration 1 - Mode 4 - 10

E-TM1.1: 10MHz Bandwidth

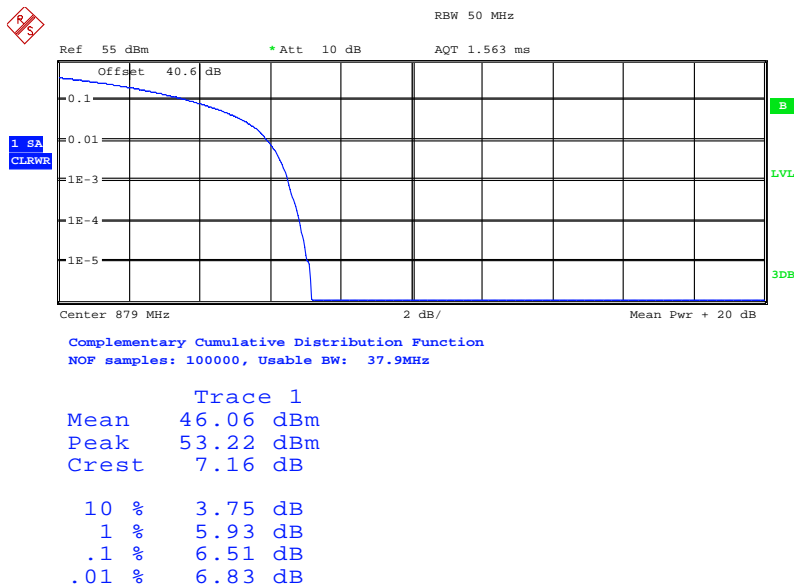

Date: 15.JUL.2013 15:53:25

Configuration 1 - Mode 5 - 1.4

E-TM1.1: 1.4MHz Bandwidth

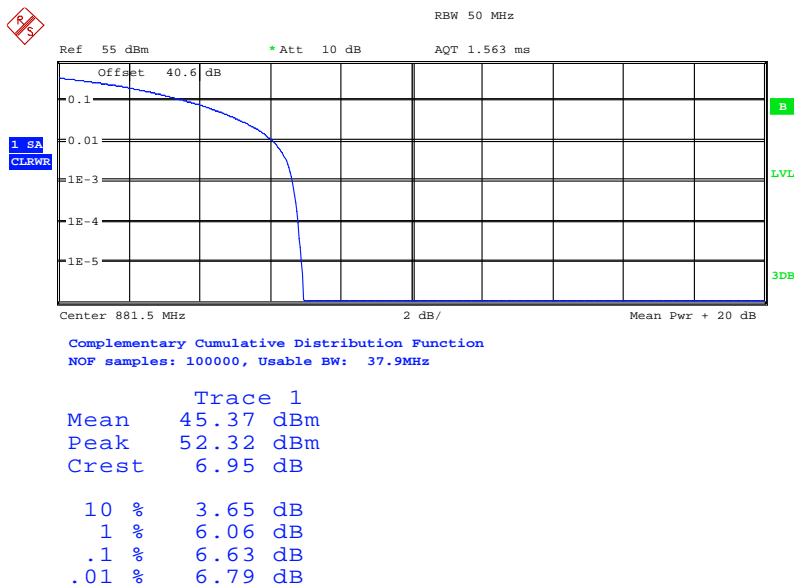

Date: 16.JUL.2013 11:43:33



Configuration 1 - Mode 5 - 3

E-TM1.1: 3MHz Bandwidth

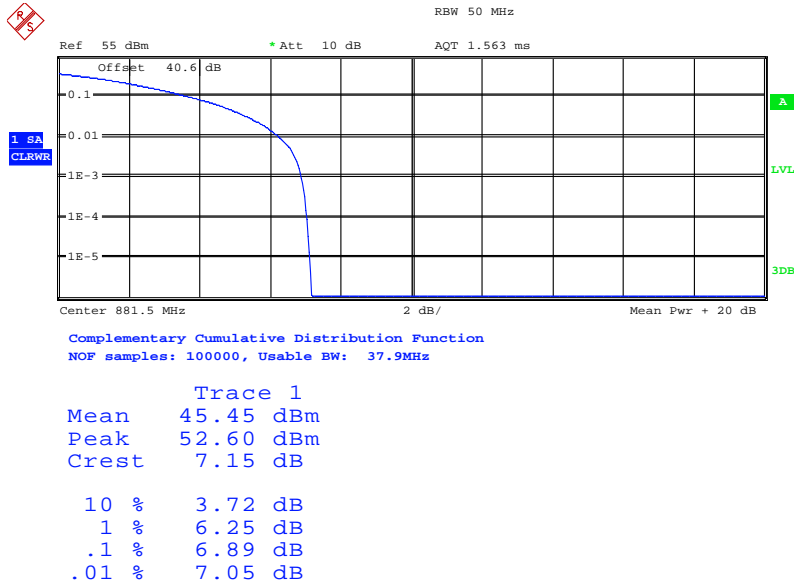

Date: 15.JUL.2013 13:27:44

Configuration 1 - Mode 5 - 5

E-TM1.1: 5MHz Bandwidth

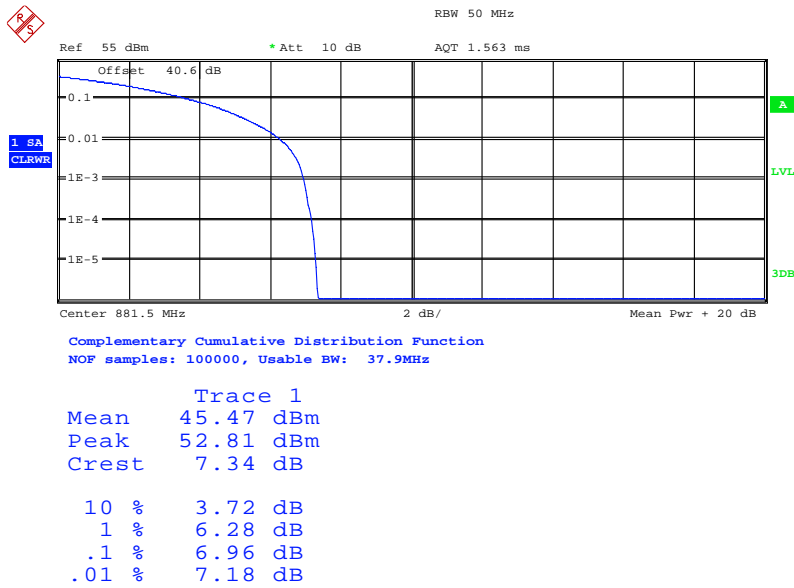

Date: 15.JUL.2013 13:42:21



Configuration 1 - Mode 5 - 10

E-TM1.1: 10MHz Bandwidth

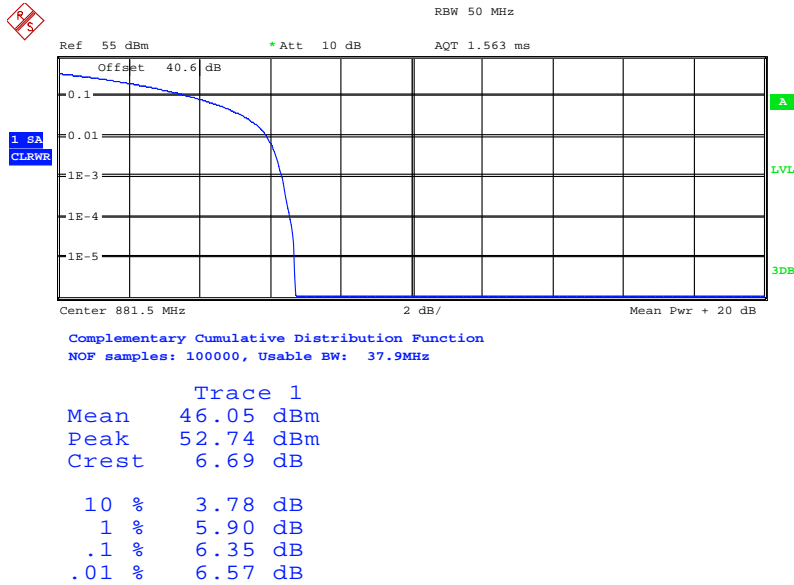

Date: 15.JUL.2013 13:50:59

Configuration 1 - Mode 6 - 1.4

E-TM1.1: 1.4MHz Bandwidth

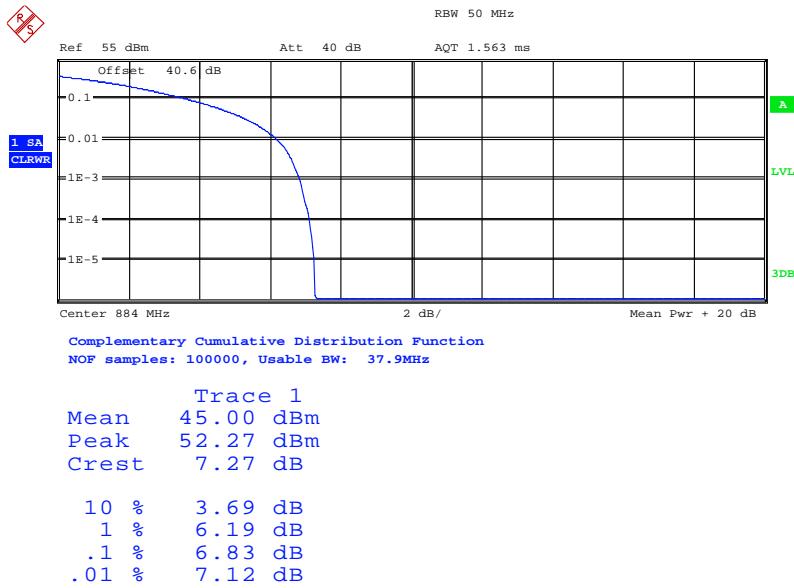

Date: 16.JUL.2013 12:11:09



Configuration 1 - Mode 6 - 10

E-TM1.1: 10MHz Bandwidth

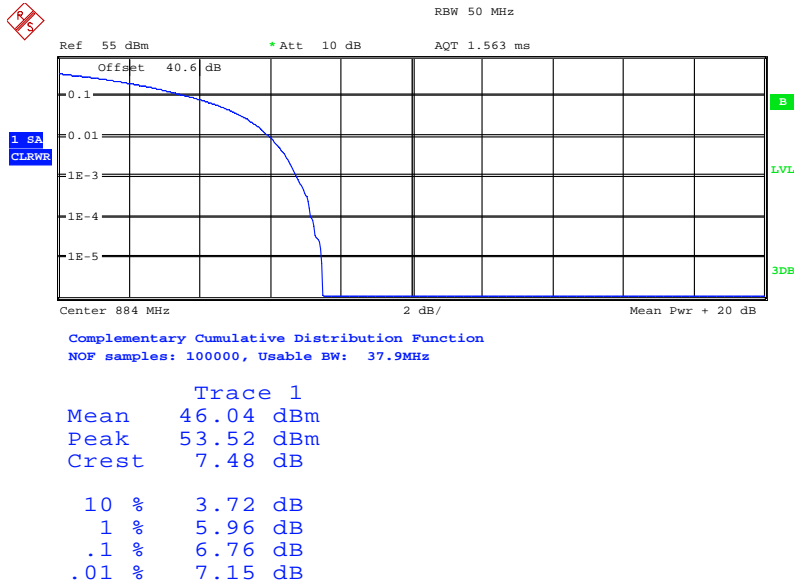

Date: 15.JUL.2013 16:43:17

Limit	13dB
-------	------

Remarks

The Peak – Average ratio does not exceed 13dB at the measured frequencies.



Product Service

2.3 MODULATION CHARACTERISTICS

2.3.1 Specification Reference

FCC CFR 47 Part 2, Clause 2.1047 (d)
Industry Canada RSS-132, Clause 5.2

2.3.2 Equipment Under Test

RRUS 11 B5 / KRC 161 285/2, S/N: CB4P587217

2.3.3 Date of Test and Modification State

15 July 2013 – Modification State 0

2.3.4 Test Method and Operating Modes

The test was applied in accordance with the test method requirements of FCC CFR 47 Part 2 and Industry Canada RSS-132.

Connect the TX output connector RF A to a spectrum analyzer with an attenuator. The other connector RF B was connected to match load. The EUT was controlled to transmit maximum power. Measure and record the constellation of the EUT by the spectrum analyzer.

The EUT supports QPSK, 16QAM and 64QAM modulations and was tested in 3.0MHz Bandwidth.

The test was performed with the EUT in the following configurations and modes of operation:

Configuration 1 - Mode 2 (3.0MHz OBW)

2.3.5 Environmental Conditions

	15 July 2013
Ambient Temperature	23.0°C
Relative Humidity	64.5%



2.3.6 Test Results

For the period of test the EUT met the requirements of FCC CFR 47 Part 2 and Industry Canada RSS-132 for Modulation Characteristics.

The test results are shown below

Single Carrier

Configuration 1 - Mode 2

3.0MHz Bandwidth

E-TM1.1: EUT transmitting with QPSK modulation:

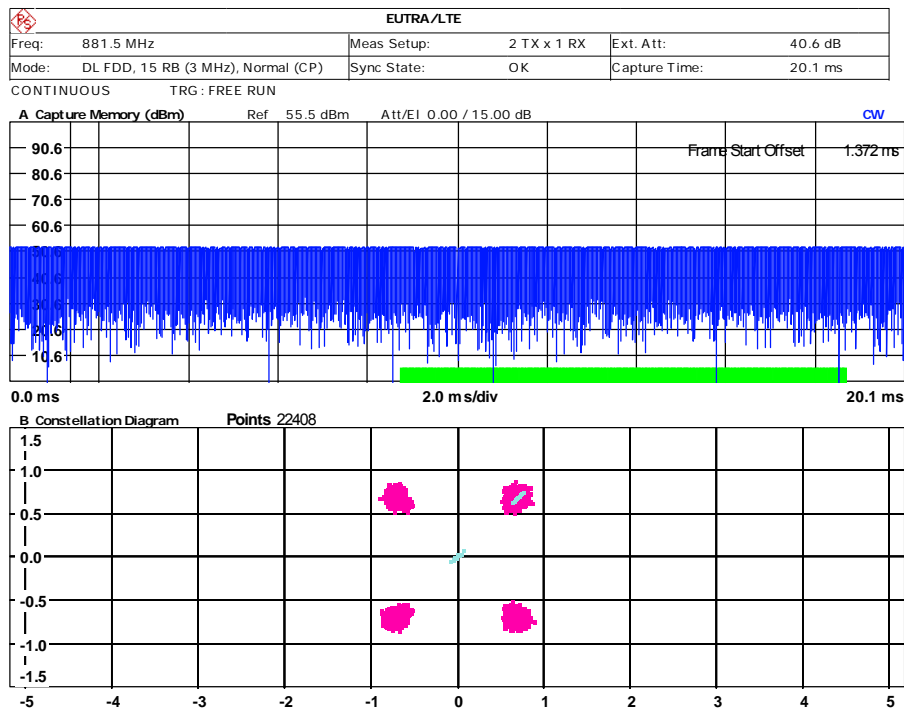

Running ...

Date: 15.JUL.2013 10:16:14



E-TM3.2: EUT transmitting with 16QAM modulation:

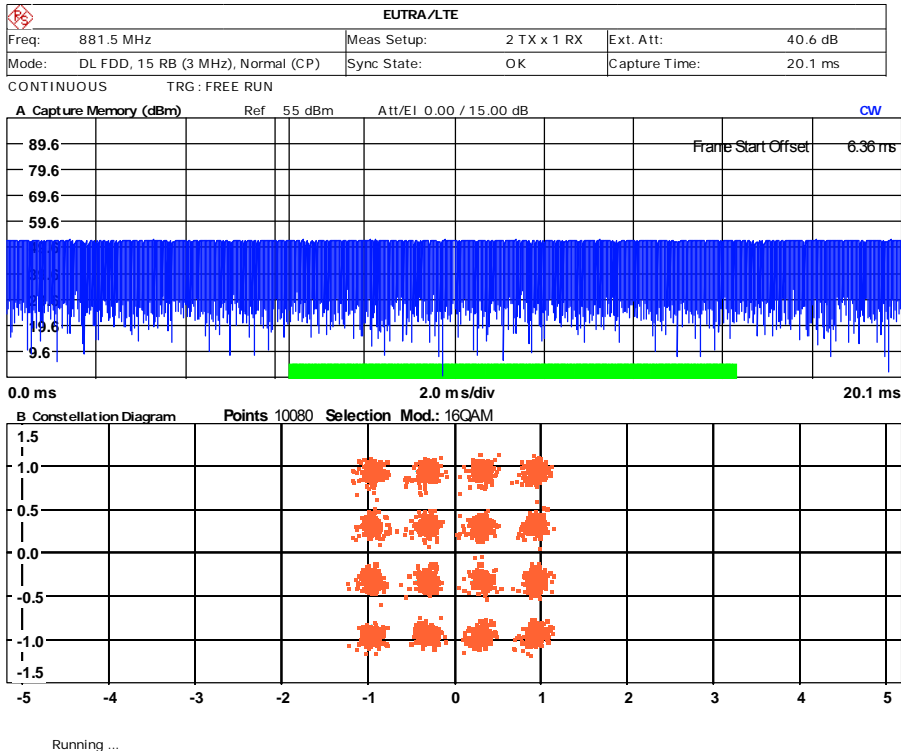

Date: 15.JUL.2013 10:19:25

E-TM3.1: EUT transmitting with 64QAM modulation:

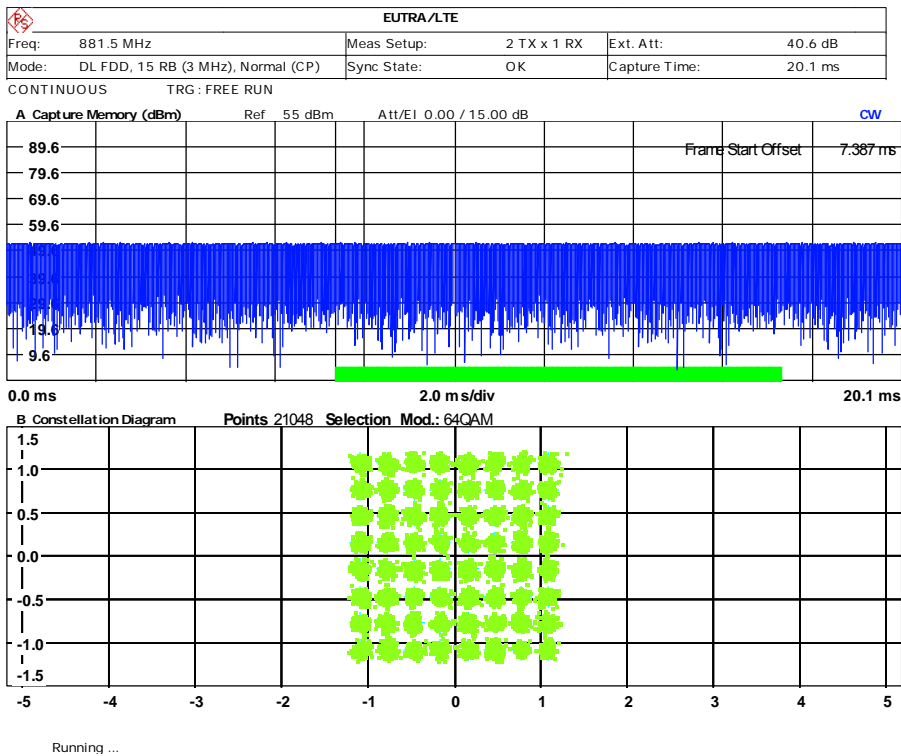

Date: 15.JUL.2013 10:21:22



Product Service

2.4 OCCUPIED BANDWIDTH

2.4.1 Specification Reference

FCC CFR 47 Part 2, Clause 2.1049
FCC CFR 47 Part 22, Clause 22.917(b)
Industry Canada RSS-GEN, Clause 4.6.1

2.4.2 Equipment Under Test

RRUS 11 B5 / KRC 161 285/2, S/N: CB4P587217

2.4.3 Date of Test and Modification State

11 July 2013 – Modification State 0

2.4.4 Test Equipment Used

The major items of test equipment used for the above tests are identified in Section 3.1.

2.4.5 Test Method and Operating Modes

The test was applied in accordance with the test method requirements of FCC CFR 47 Part 2 and Part 22 and Industry Canada RSS-GEN.

The EUT was transmitting at maximum power, modulated using the test models described. The EUT was tested in the 6 bandwidths. At least 1% of the emission bandwidth were used for the resolution bandwidth.

The occupied bandwidth, that is the frequency bandwidth such that, below its lower and above its upper frequency limits, the mean powers radiated are each equal to 0.5 percent of the total mean power radiated by a given emission.

The test was performed with the EUT in the following configurations and modes of operation:

Configuration 1 - Mode 1 - 1.4, Mode 1 - 20
- Mode 2(1.4MHz, 3.0MHz, 5.0MHz, 10.0MHz, 15.0MHz, 20.0MHz OBW)
- Mode 3 - 1.4, Mode 3 - 20

2.4.6 Environmental Conditions

11 July 2013

Ambient Temperature 22.0°C

Relative Humidity 61.0%



2.4.7 Test Results

For the period of test the EUT met the requirements of FCC CFR 47 Part 2 and Part 22 and Industry Canada RSS-GEN for Occupied Bandwidth.

The test results are shown below

Test Model	BW configuration (MHz)	Frequency (MHz) / Channel	Occupied Bandwidth (MHz)
E-TM1.1	1.4	2620.7 (Bottom)	1.09
	20.0	2630.0 (Bottom)	17.95
	1.4	2655.0 (Middle)	1.09
	3.0	2655.0 (Middle)	2.69
	5.0	2655.0 (Middle)	4.47
	10.0	2655.0 (Middle)	8.97
	15.0	2655.0 (Middle)	13.46
	20.0	2655.0 (Middle)	17.87
	1.4	2689.3 (Top)	1.09
	20.0	2680.0 (Top)	17.87
E-TM3.2	1.4	2655.0 (Middle)	1.09
	20.0	2655.0 (Middle)	17.87
E-TM3.1	1.4	2655.0 (Middle)	1.09
	20.0	2655.0 (Middle)	17.87



E-TM1.1

Configuration 1 - Mode 1 - 1.4

1.4MHz Bandwidth

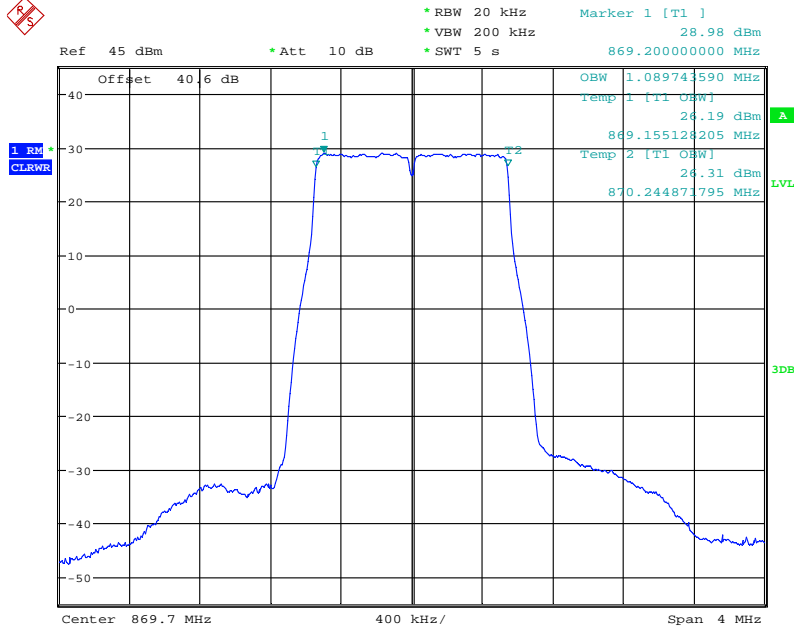

Date: 11.JUL.2013 16:21:09

Configuration 1 - Mode 1 - 20

20.0MHz Bandwidth

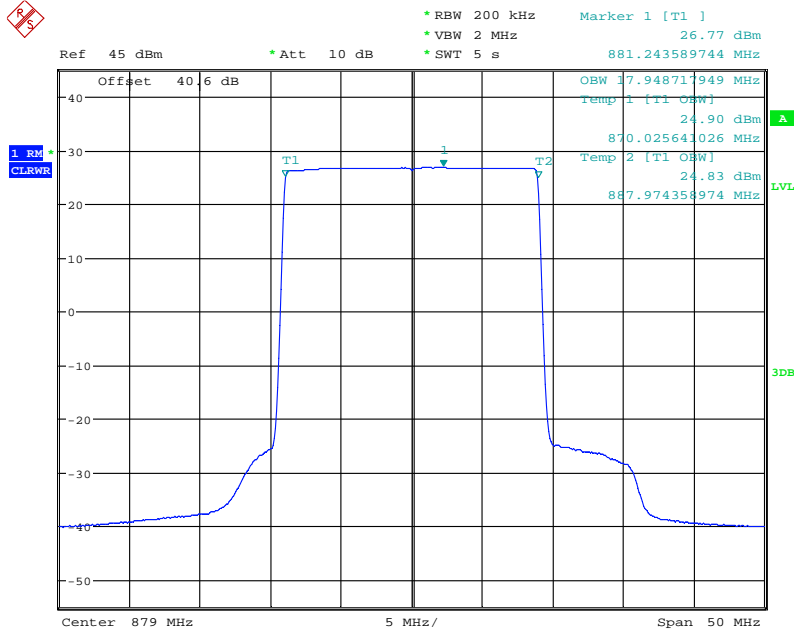

Date: 11.JUL.2013 16:36:24



Configuration 1 - Mode 2

1.4MHz Bandwidth

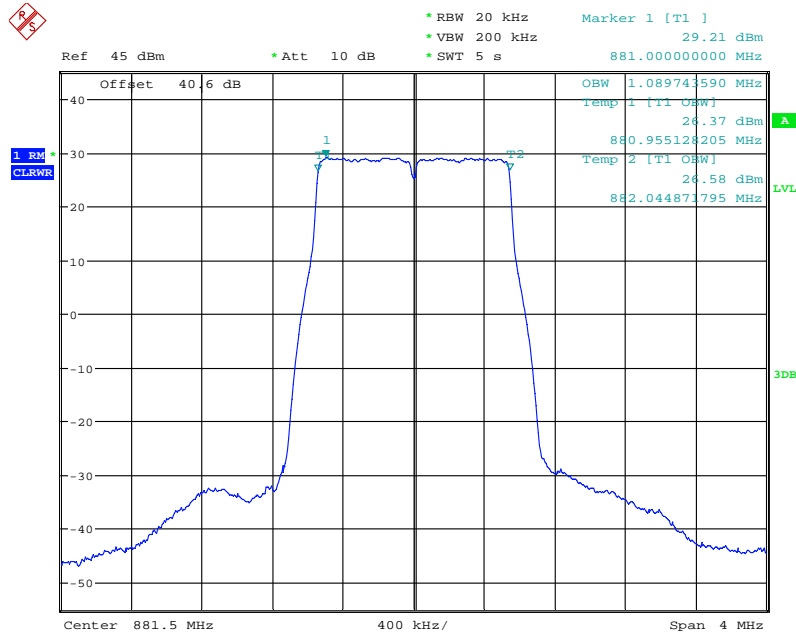

Date: 11.JUL.2013 09:54:42

3.0MHz Bandwidth

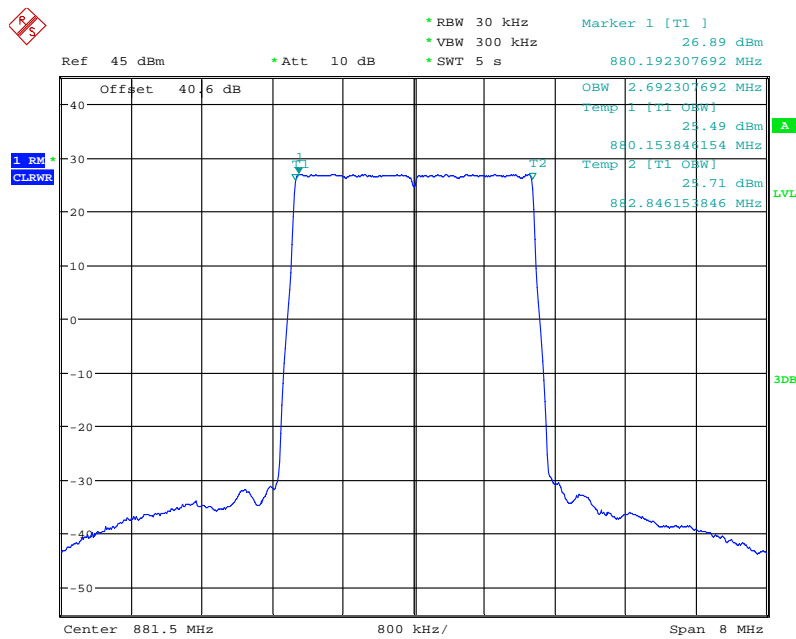

Date: 11.JUL.2013 11:21:12



5.0MHz Bandwidth

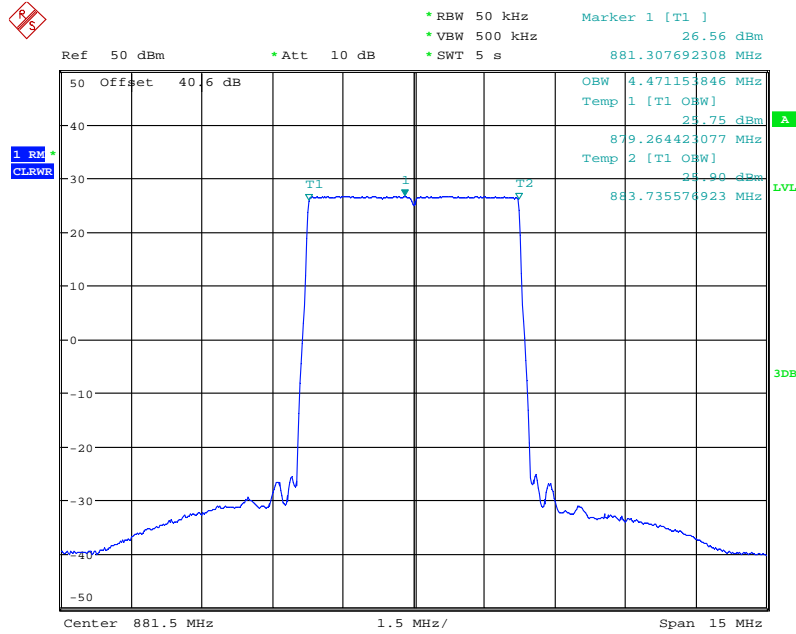

Date: 11.JUL.2013 13:10:30

10.0MHz Bandwidth

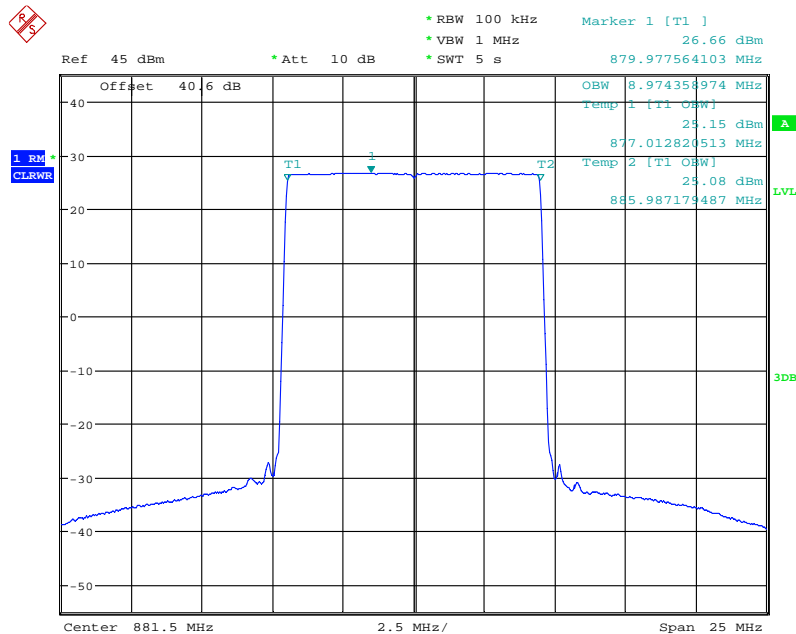

Date: 11.JUL.2013 13:21:09



15.0MHz Bandwidth

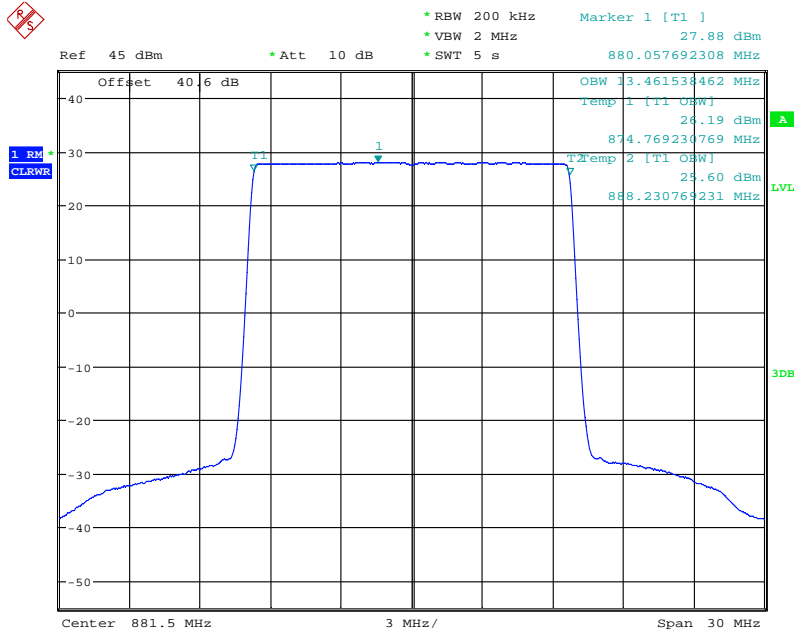

Date: 11.JUL.2013 13:34:42

20.0MHz Bandwidth

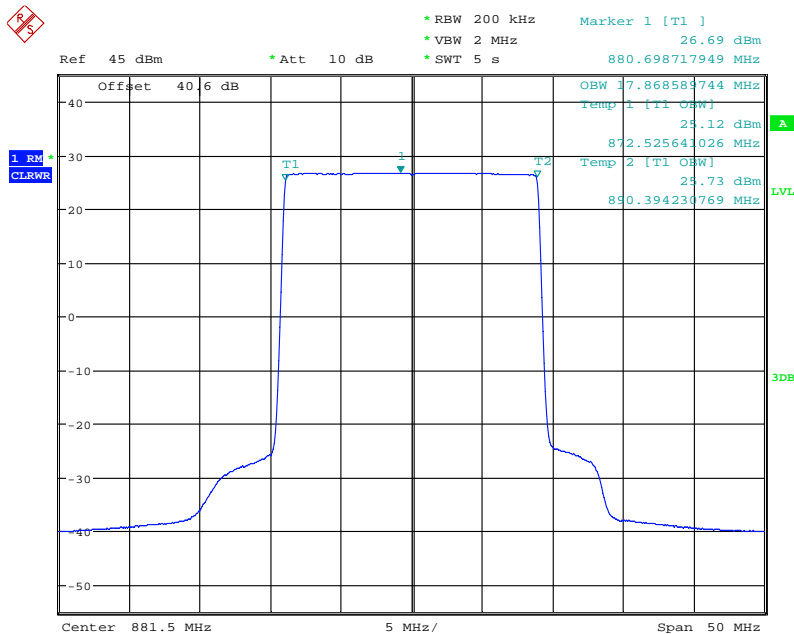

Date: 11.JUL.2013 11:00:19



Configuration 1 - Mode 3 - 1.4

1.4MHz Bandwidth

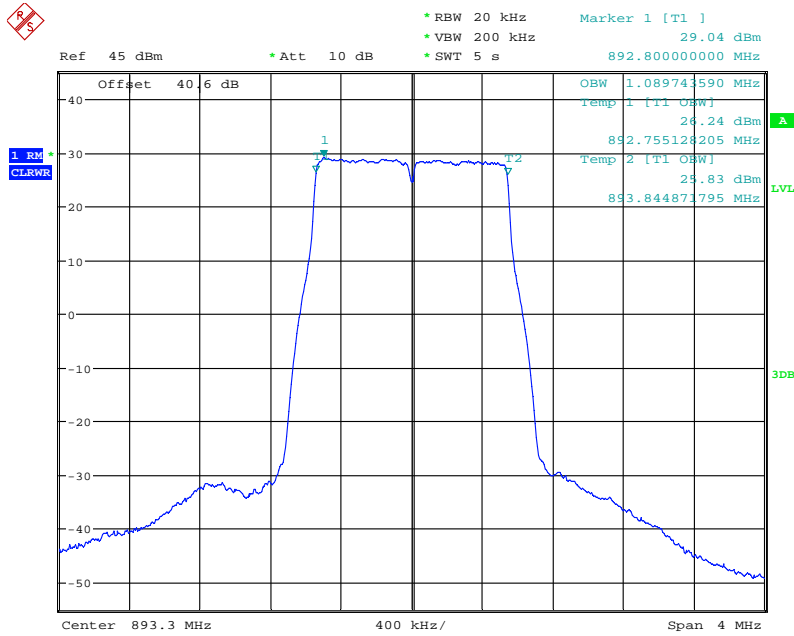

Date: 11.JUL.2013 15:58:15

Configuration 1 - Mode 3 - 20

20.0MHz Band

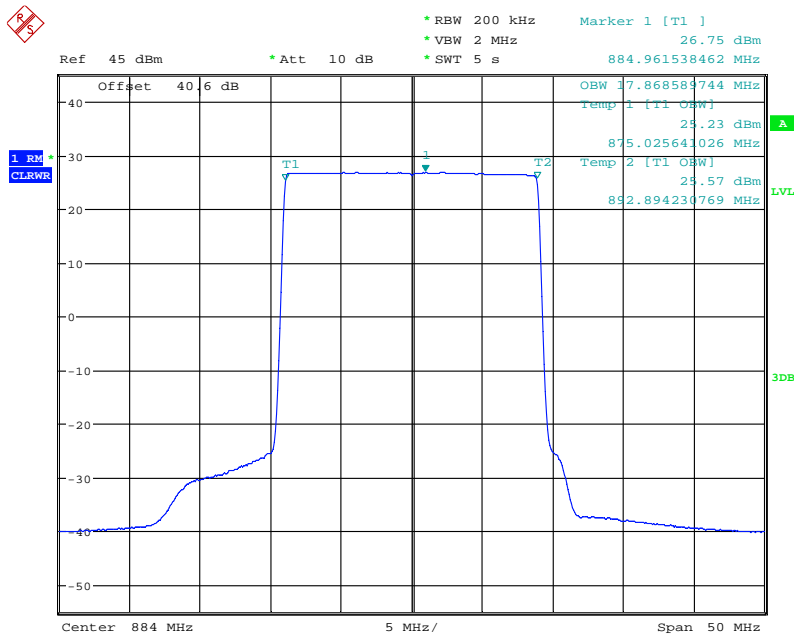

Date: 11.JUL.2013 17:23:17



E-TM3.2

Configuration 1 - Mode 2

1.4MHz Bandwidth

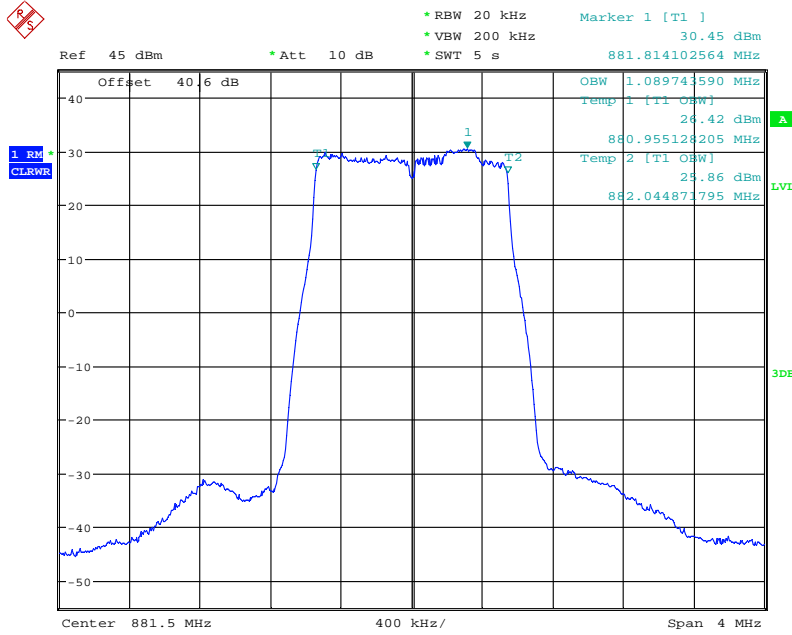

Date: 11.JUL.2013 13:47:06

20.0MHz Bandwidth

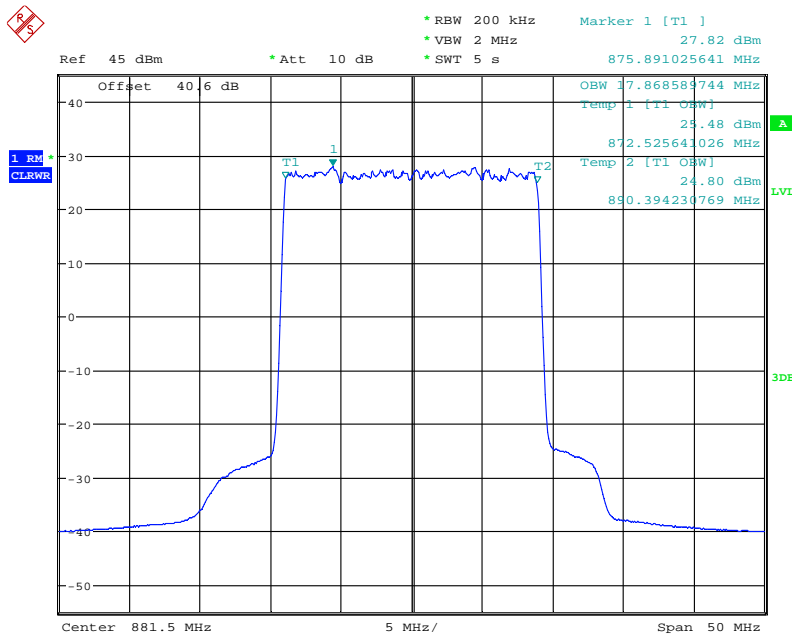

Date: 11.JUL.2013 14:10:51



E-TM3.1

Configuration 1 - Mode 2

1.4MHz Bandwidth

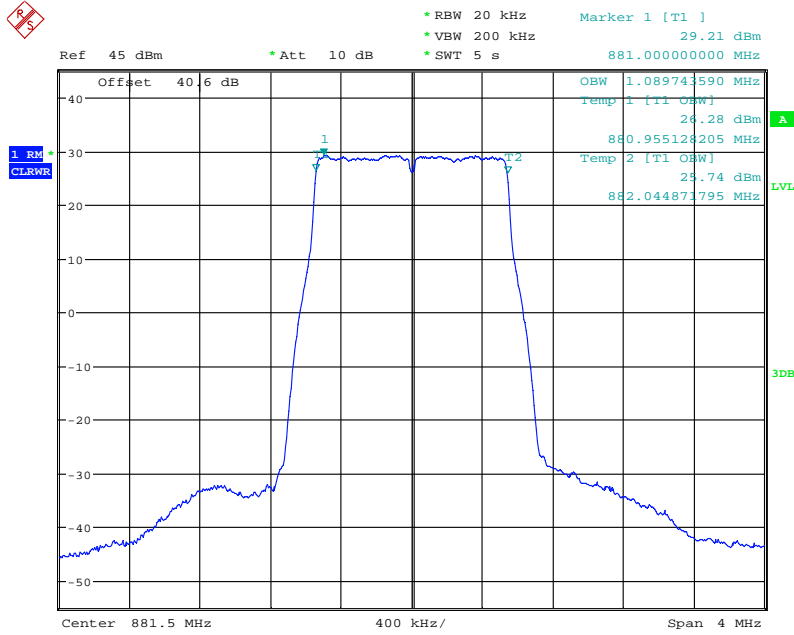

Date: 11.JUL.2013 14:04:49

20.0MHz Bandwidth

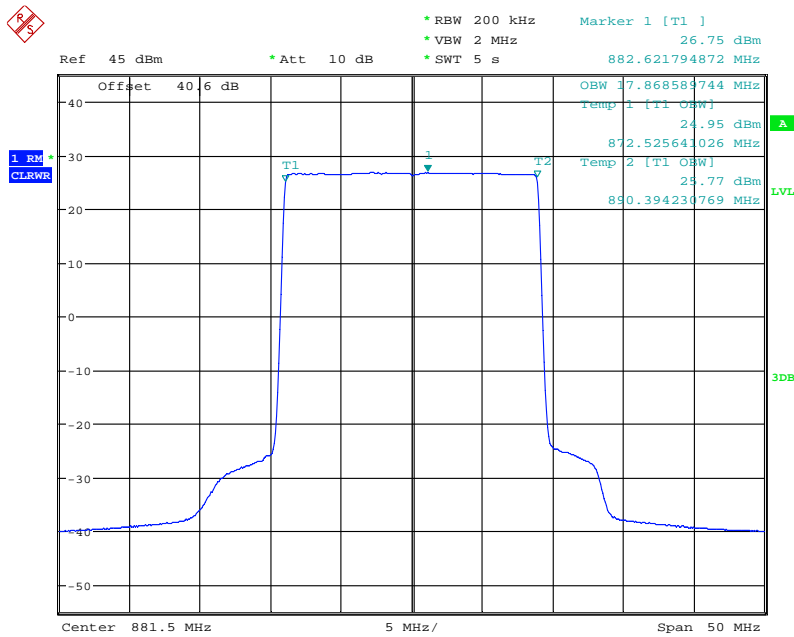

Date: 11.JUL.2013 14:26:11



Product Service

2.5 SPURIOUS EMISSIONS AT ANTENNA TERMINALS (± 1 MHz)

2.5.1 Specification Reference

FCC CFR 47 Part 2, Clause 2.1051
FCC CFR 47 Part 22, Clause 22.917(b)
Industry Canada RSS-132 Clause 5.5

2.5.2 Equipment Under Test

RRUS 11 B5 / KRC 161 285/2, S/N: CB4P587217

2.5.3 Date of Test and Modification State

11 and 15 July 2013 – Modification State 0

2.5.4 Test Equipment Used

The major items of test equipment used for the above tests are identified in Section 3.1.

2.5.5 Test Method and Operating Modes

The test was applied in accordance with the test method requirements of FCC CFR 47 Part 2 and Part 22 and Industry Canada RSS-132.

In accordance with 22.917(b), at least 1% of the emission bandwidth should be used for the frequencies up to 1MHz away from the block edge. According to the FCC rules, a RBW of 100kHz for measurements of emissions > 1MHz away from the band edges. Spectrum analyser detector was set as RMS.

The limit was adjusted with a correction of -3dB [10Log(2)] by using the Measure and Add 10Log(N) dB technique according to FCC KDB662911 D01 accounting for simultaneous transmission from antenna ports RF A and RF B. The limit was adjusted to -16dBm.

The path loss measured and entered as a reference level offset.

The EUT was tested at its maximum power level.

The test was performed with the EUT in the following configurations and modes of operation:

- Configuration 1 - Mode 1 - 1.4, Mode 1 - 3, Mode 1 - 5,
Mode 1 - 10, Mode 1 - 15, Mode 1 - 20
- Mode 3 - 1.4, Mode 3 - 3, Mode 3 - 5,
Mode 3 - 10, Mode 3 - 15, Mode 3 - 20
- Mode 4' - 1.4, Mode 4' - 3, Mode 4' - 5, Mode 4 - 10
- Mode 6' - 1.4, Mode 6' - 3, Mode 6' - 5, Mode 6 - 10



Product Service

2.5.6 Environmental Conditions

	11 July 2013	15 July 2013
Ambient Temperature	22.0°C	23.0°C
Relative Humidity	61.0%	64.5%

2.5.7 Test Results

For the period of test the EUT met the requirements of FCC CFR 47 Part 2 and Part 22 and Industry Canada RSS-132 for Spurious Emissions Antenna Terminals (± 1 MHz)

Below are the Frequencies the EUT was tested against along with the tested channels.

Single Carrier

ETM1.1

Bandwidth: 1.4MHz

Configuration 1 - Mode 1 -1.4 and Mode 3 - 1.4

Band Edge Frequency	Bottom 869 MHz	Top 894 MHz	RBW / VBW (Hz)	Limit (dBm)
Edge Test with 1.4MHz Bandwidth Channel No./Frequencies	Channel: 2407 Frequency: 869.7 MHz	Channel: 2643 Frequency: 893.3 MHz	20k / 200k	-16.0

Bandwidth: 3.0MHz

Configuration 1 - Mode 1 - 3 and Mode 3 - 3

Band Edge Frequency	Bottom 869 MHz	Top 894 MHz	RBW / VBW (Hz)	Limit (dBm)
Edge Test with 3.0MHz Bandwidth Channel No./Frequencies	Channel: 2415 Frequency: 870.5 MHz	Channel: 2635 Frequency: 892.5MHz	30k / 300k	-16.0



Product Service

Bandwidth: 5.0MHz

Configuration 1 - Mode 1 - 5 and Mode 3 - 5

Band Edge Frequency	Bottom 869 MHz	Top 894 MHz	RBW / VBW (Hz)	Limit (dBm)
Edge Test with 5.0MHz Bandwidth Channel No./Frequencies	Channel: 2425 Frequency: 871.5 MHz	Channel: 2625 Frequency: 891.5 MHz	50k / 500k	-16.0

Bandwidth: 10.0MHz

Configuration 1 - Mode 1 - 10 and Mode 3 - 10

Band Edge Frequency	Bottom 869 MHz	Top 894 MHz	RBW / VBW (Hz)	Limit (dBm)
Edge Test with 10.0MHz Bandwidth Channel No./Frequencies	Channel: 2450 Frequency: 874.0 MHz	Channel: 2600 Frequency: 889.0 MHz	100k / 1M	-16.0

Bandwidth: 15.0MHz

Configuration 1 - Mode 1 - 15 and Mode 3 - 15

Band Edge Frequency	Bottom 869 MHz	Top 894 MHz	RBW / VBW (Hz)	Limit (dBm)
Edge Test with 15.0MHz Bandwidth Channel No./Frequencies	Channel: 2475 Frequency: 876.5 MHz	Channel: 2575 Frequency: 886.5 MHz	200k / 2M	-16.0

Bandwidth: 20.0MHz

Configuration 1 - Mode 1 - 20 and Mode 3 - 20

Band Edge Frequency	Bottom 869 MHz	Top 894 MHz	RBW / VBW (Hz)	Limit (dBm)
Edge Test with 20.0MHz Bandwidth Channel No./Frequencies	Channel: 2500 Frequency: 879.0 MHz	Channel: 2550 Frequency: 884.0 MHz	200k / 2M	-16.0

**Multi Carrier (x2)****ETM1.1**Bandwidth: 1.4MHzConfiguration 1 - Mode 4' - 1.4 and Mode 6' - 1.4

Band Edge Frequency	Bottom 869 MHz	Top 894 MHz	RBW / VBW (Hz)	Limit (dBm)
Edge Test with 1.4MHz Bandwidth Channel No./Frequencies	Channel: 2407 + 2421 Frequency: 869.7 MHz + 871.1 MHz	Channel: 2643 + 2629 Frequency: 893.3 MHz + 891.9 MHz	20k / 200k	-16.0

Bandwidth: 3MHzConfiguration 1 - Mode 4' - 3 and Mode 6' - 3

Band Edge Frequency	Bottom 869 MHz	Top 894 MHz	RBW / VBW (Hz)	Limit (dBm)
Edge Test with 1.4MHz Bandwidth Channel No./Frequencies	Channel: 2415 + 2445 Frequency: 870.5 MHz + 873.5 MHz	Channel: 2635 + 2605 Frequency: 892.5 MHz + 889.5 MHz	30k / 300k	-16.0

Bandwidth: 5MHzConfiguration 1 - Mode 4' - 5 and Mode 6' - 5

Band Edge Frequency	Bottom 869 MHz	Top 894 MHz	RBW / VBW (Hz)	Limit (dBm)
Edge Test with 1.4MHz Bandwidth Channel No./Frequencies	Channel: 2425 + 2475 Frequency: 871.5 MHz + 876.5 MHz	Channel: 2625 + 2575 Frequency: 891.5 MHz + 886.5 MHz	50k / 500k	-16.0

Bandwidth: 10MHzConfiguration 1 - Mode 4 - 10 and Mode 6 - 10

Band Edge Frequency	Bottom 869 MHz	Top 894 MHz	RBW / VBW (Hz)	Limit (dBm)
Edge Test with 10MHz Bandwidth Channel No./Frequencies	Channel: 2450 + 2550 Frequency: 874.0 MHz + 884.0 MHz	Channel: 2600 + 2500 Frequency: 889.0 MHz + 879.0 MHz	100k / 1M	-16.0

The channels shown in the table above are the minimum and maximum channels that can be used in the authorised frequency ranges to maintain compliance.

The test results are shown below



Single Carrier

E-TM1.1

1.4MHz Bandwidth

Configuration 1 - Mode 1 - 1.4

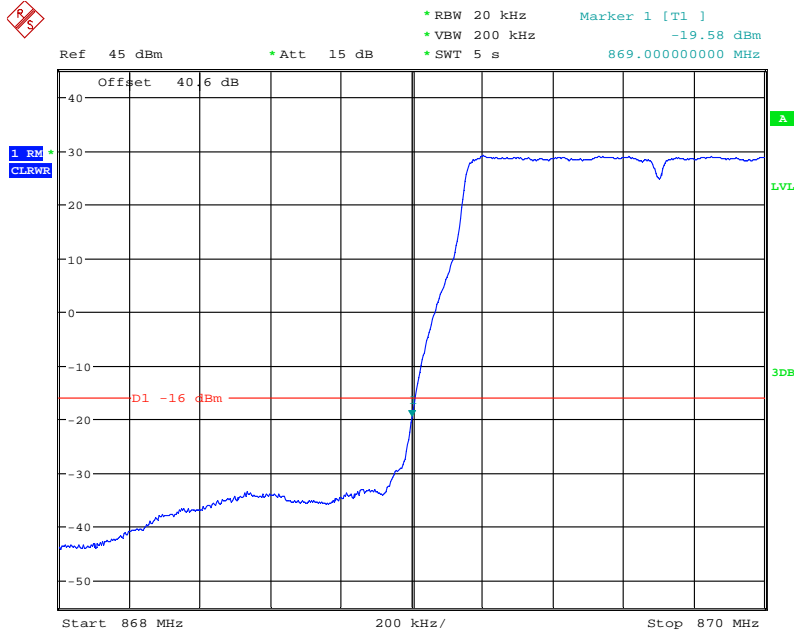

Date: 11.JUL.2013 14:39:13

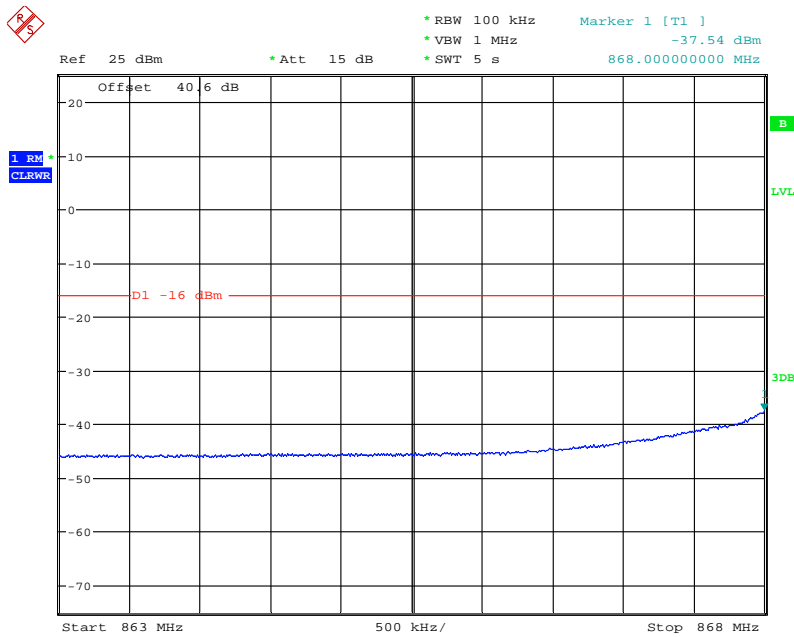

Date: 11.JUL.2013 14:41:10



Configuration 1 - Mode 3 - 1.4

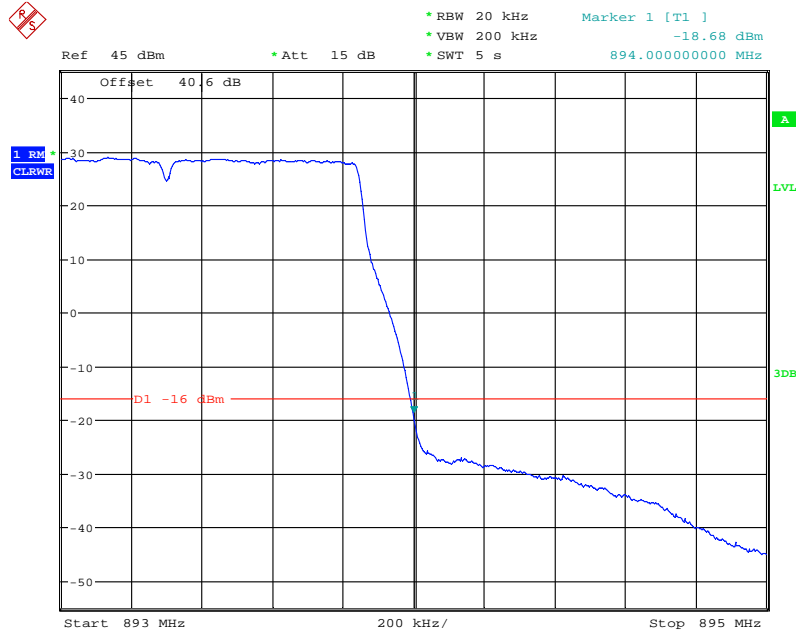

Date: 11.JUL.2013 15:47:26

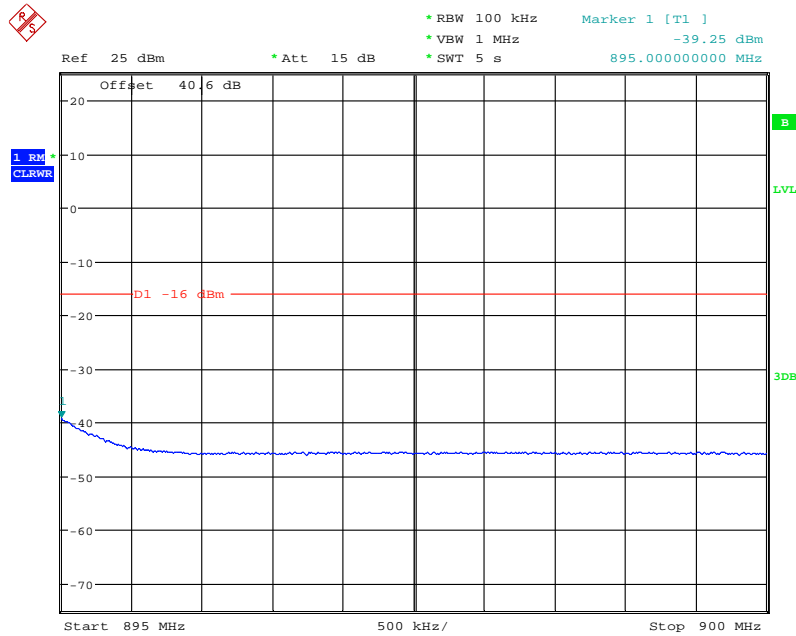

Date: 11.JUL.2013 15:47:55



Product Service

3.0MHz Bandwidth

Configuration 1 - Mode 1 - 3

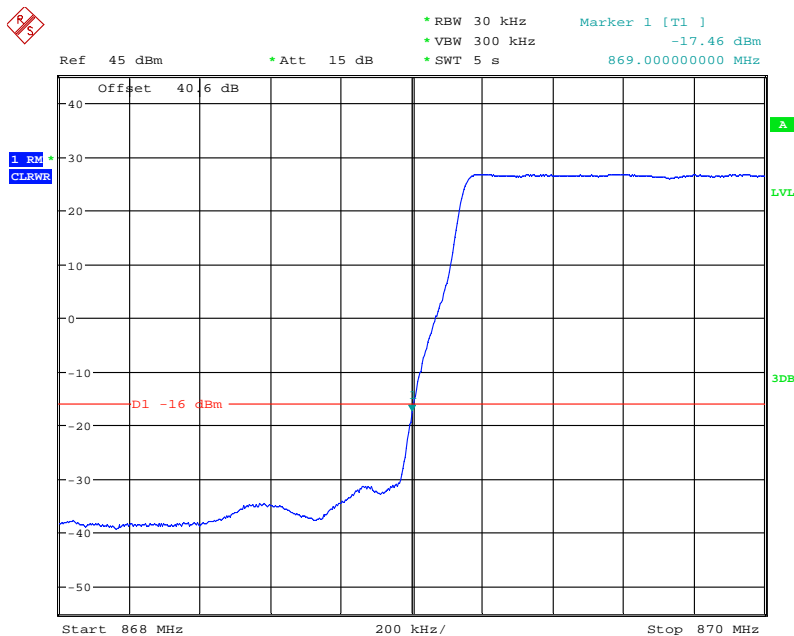

Date: 11.JUL.2013 14:48:33

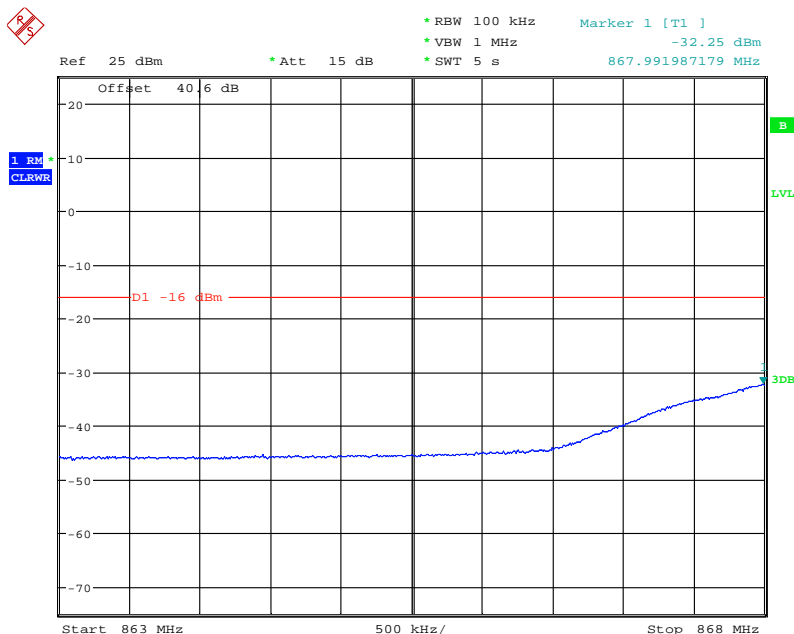

Date: 11.JUL.2013 14:48:02



Configuration 1 - Mode 3 - 3

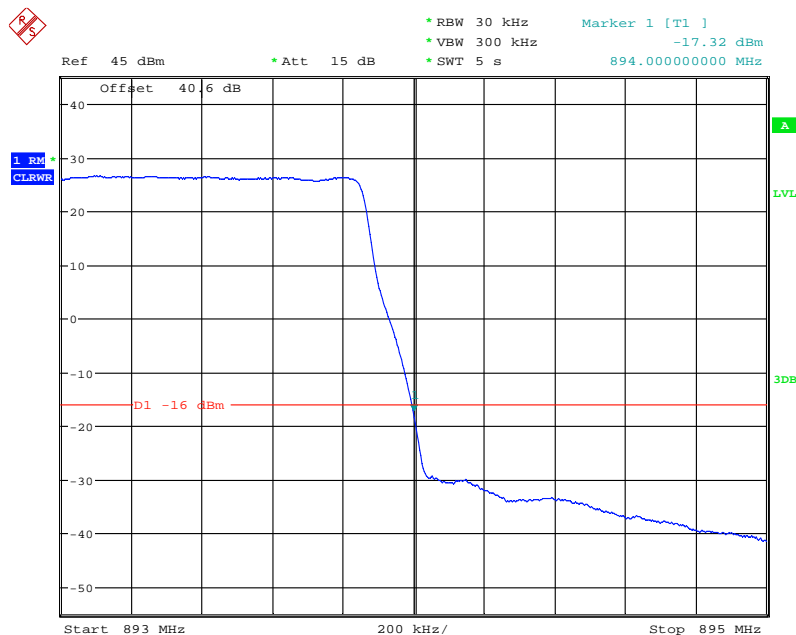

Date: 11.JUL.2013 15:31:49

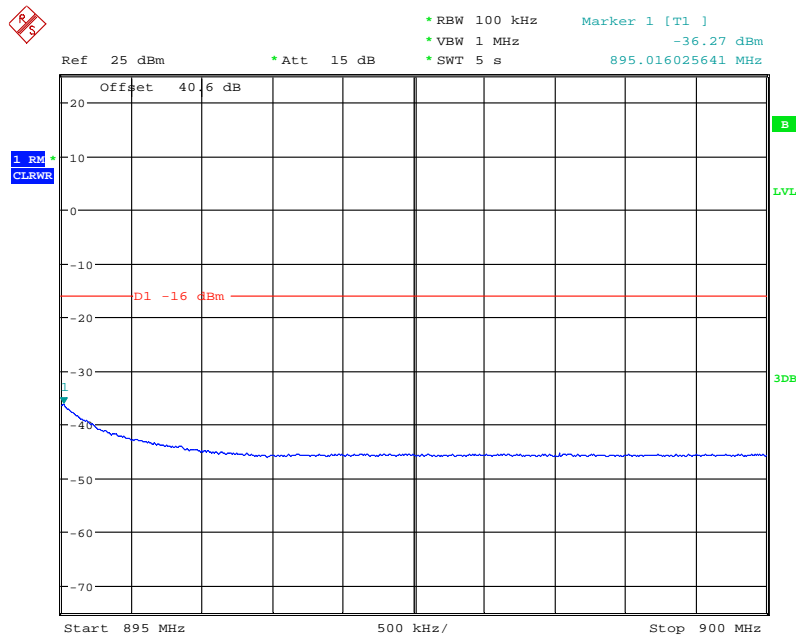

Date: 11.JUL.2013 15:31:07



5.0MHz Bandwidth

Configuration 1 - Mode 1 - 5

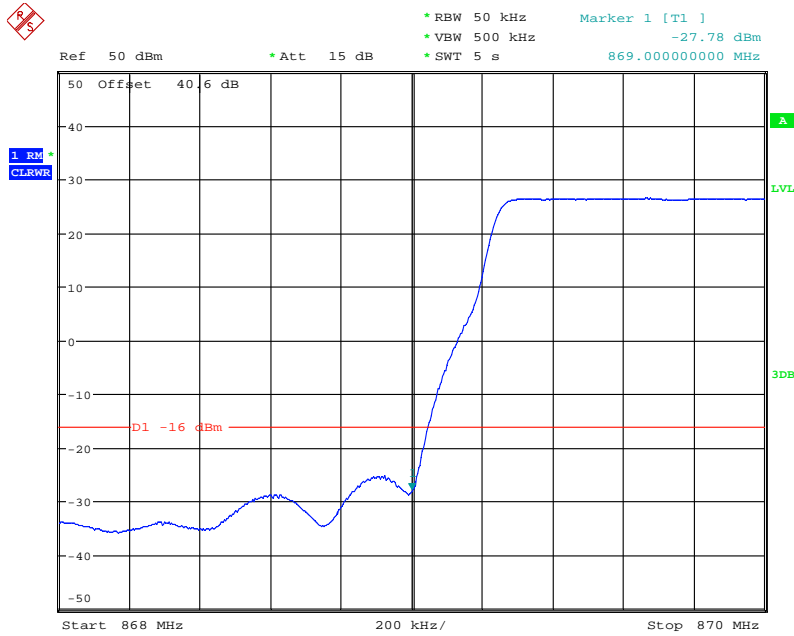

Date: 11.JUL.2013 15:06:17

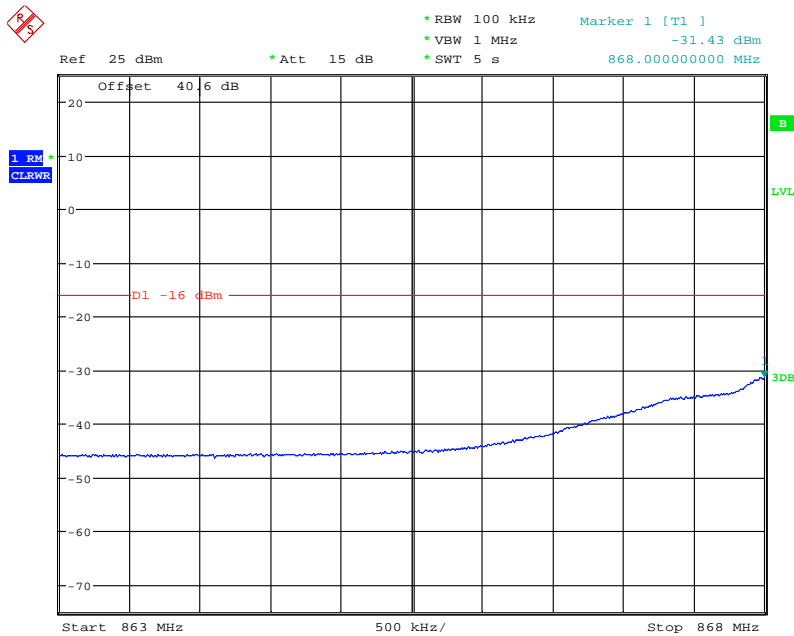

Date: 11.JUL.2013 15:06:54



Configuration 1 - Mode 3 - 5

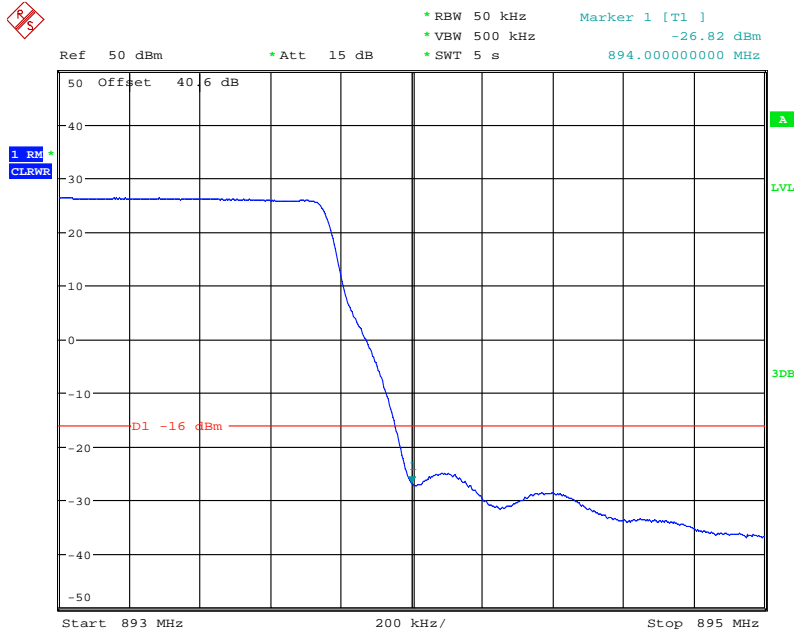

Date: 11.JUL.2013 15:23:33

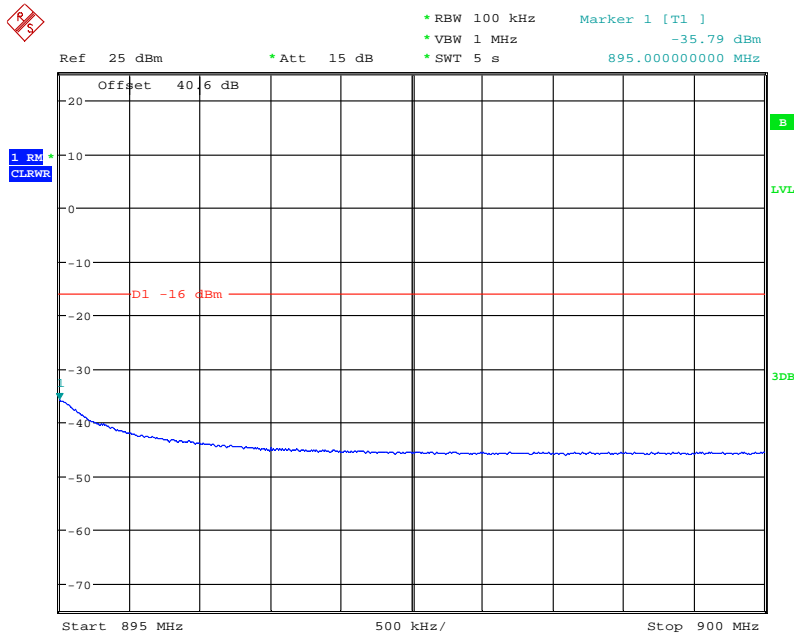

Date: 11.JUL.2013 15:24:10



10.0MHz Bandwidth

Configuration 1 - Mode 1 - 10

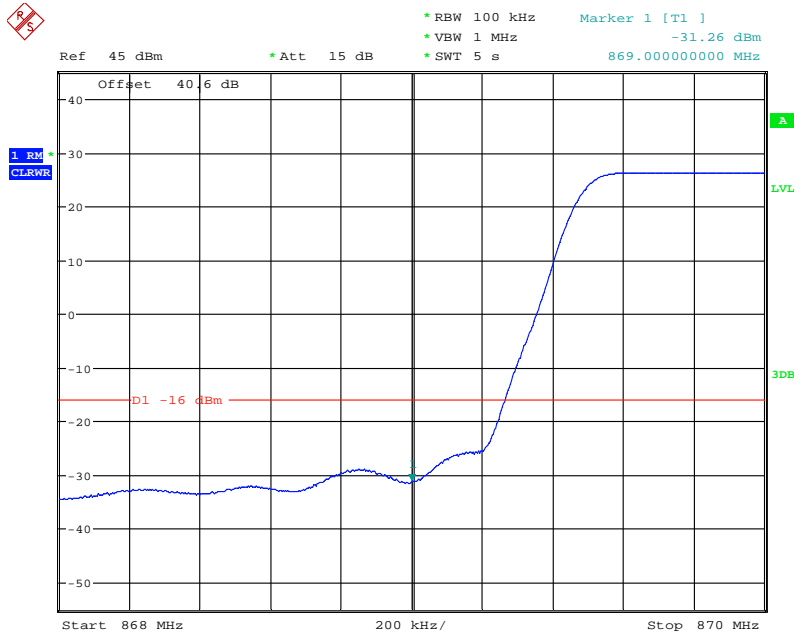

Date: 11.JUL.2013 15:08:31

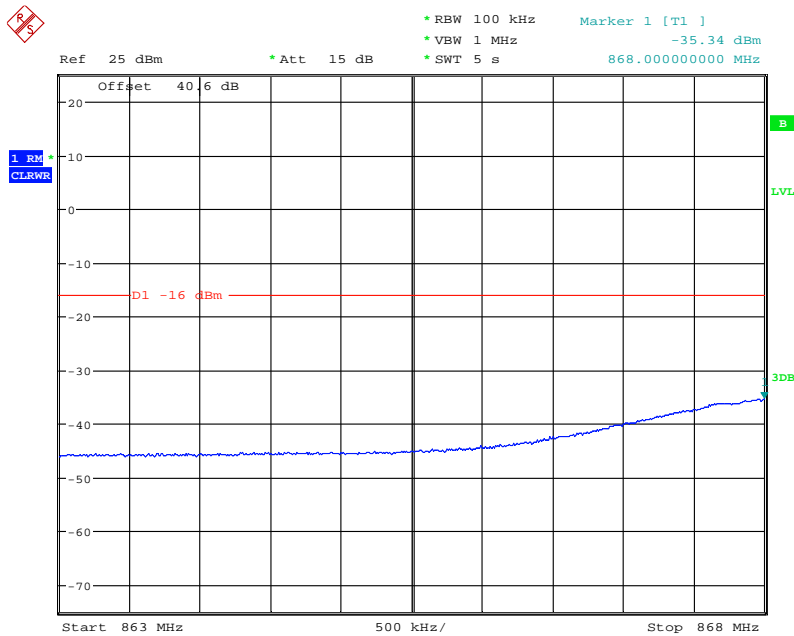

Date: 11.JUL.2013 15:08:57



Configuration 1 - Mode 3 - 10

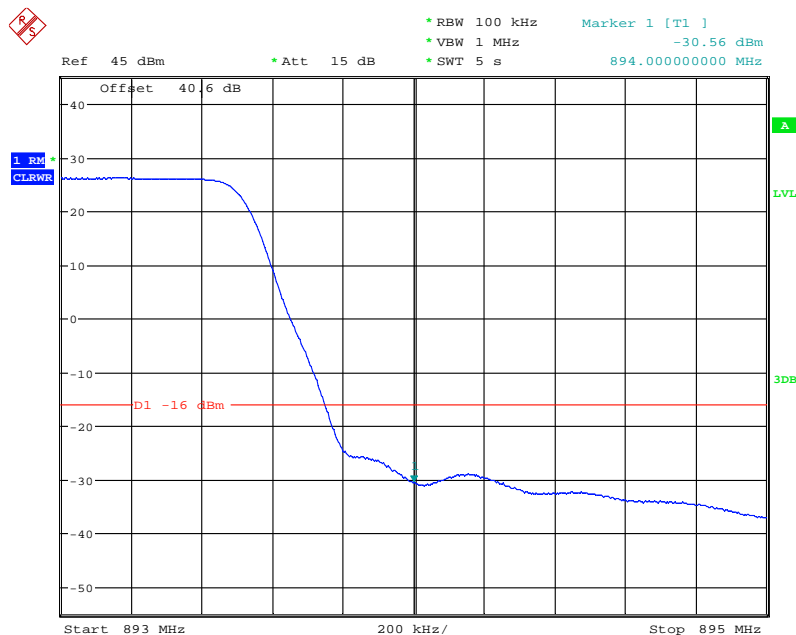

Date: 11.JUL.2013 15:21:23

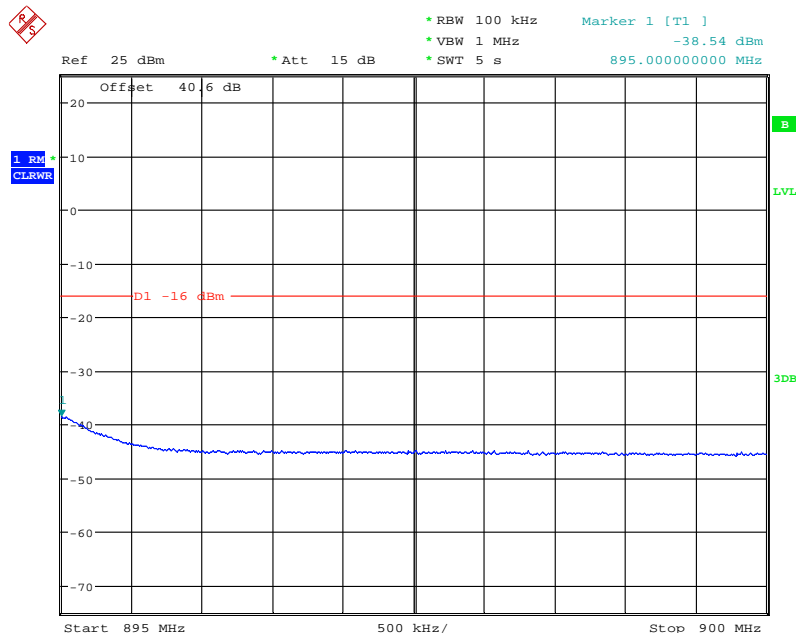

Date: 11.JUL.2013 15:21:55



15MHz Bandwidth

Configuration 1 - Mode 1 - 15

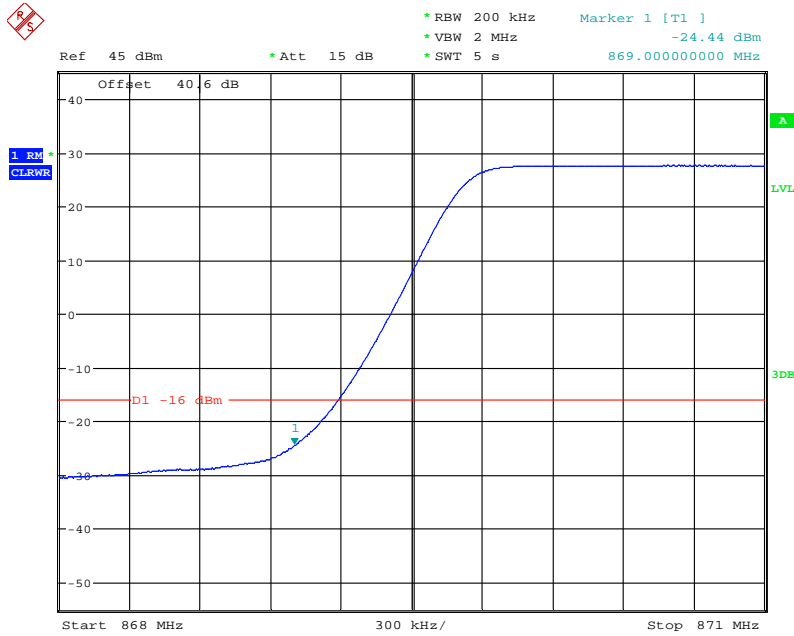

Date: 11.JUL.2013 15:10:47

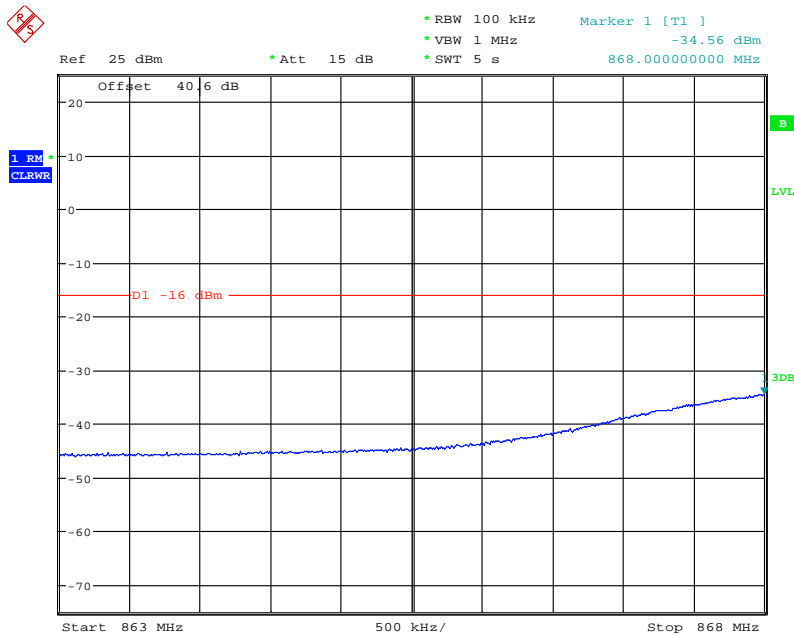

Date: 11.JUL.2013 15:11:30



Configuration 1 - Mode 3 - 15

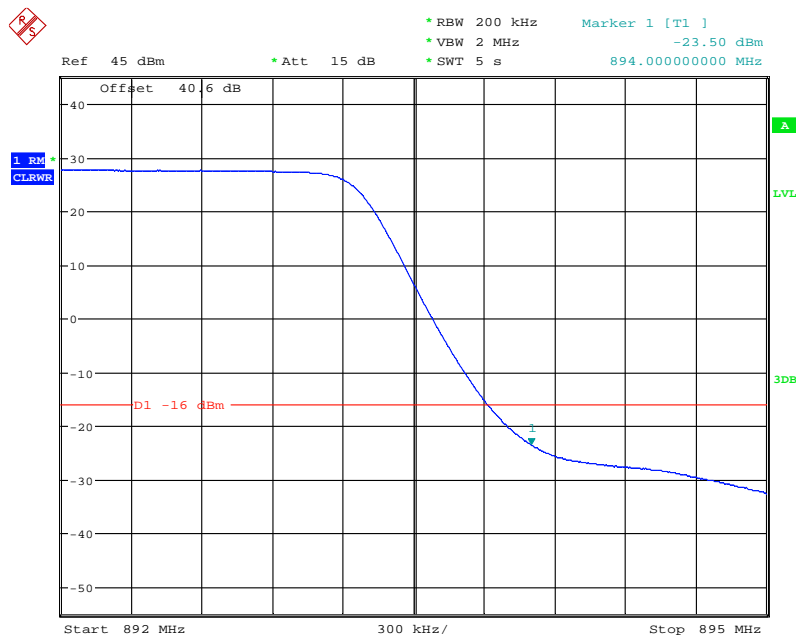

Date: 11.JUL.2013 15:19:16

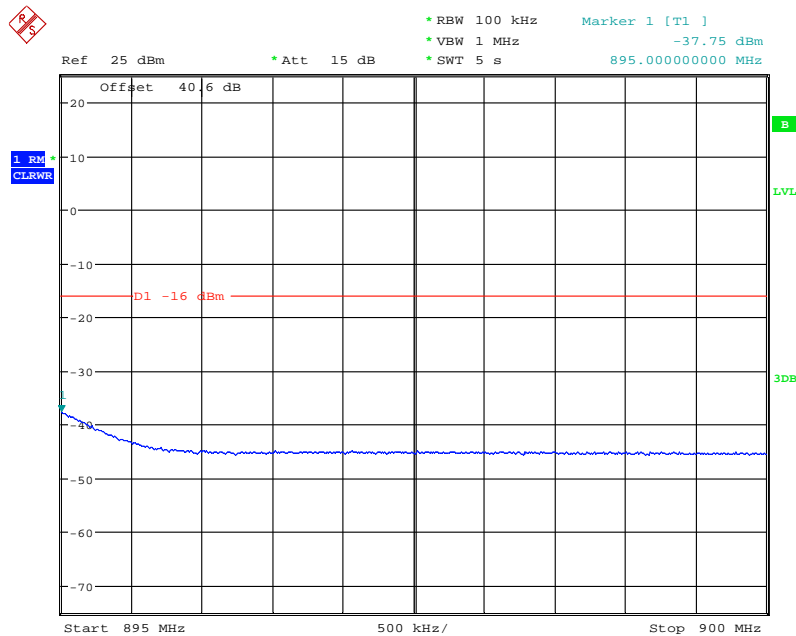

Date: 11.JUL.2013 15:19:39



20MHz Bandwidth

Configuration 1 - Mode 1 - 20

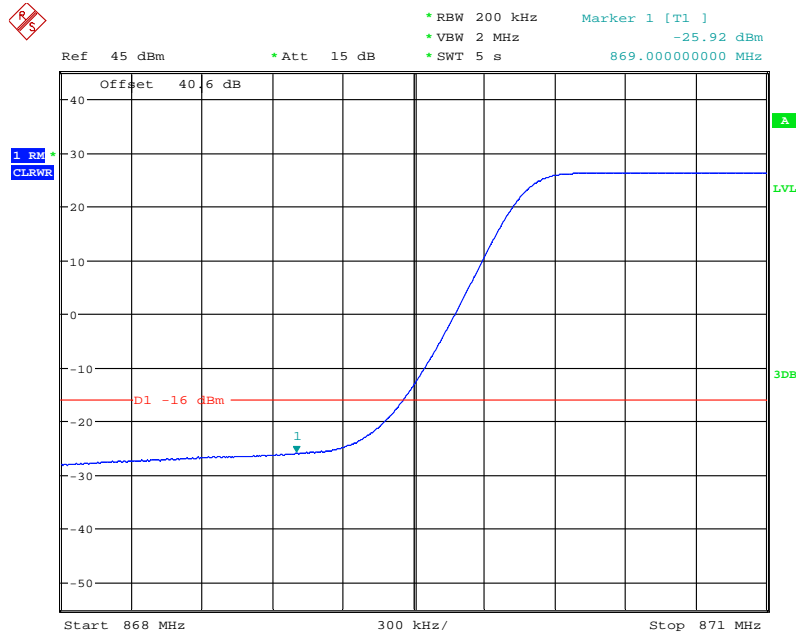

Date: 11.JUL.2013 15:14:37

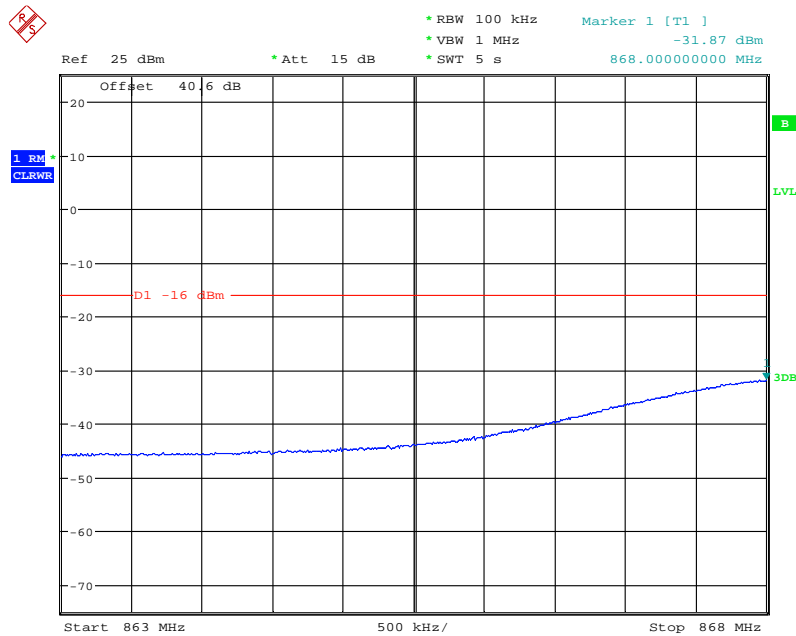

Date: 11.JUL.2013 15:14:13



Configuration 1 - Mode 3 - 20

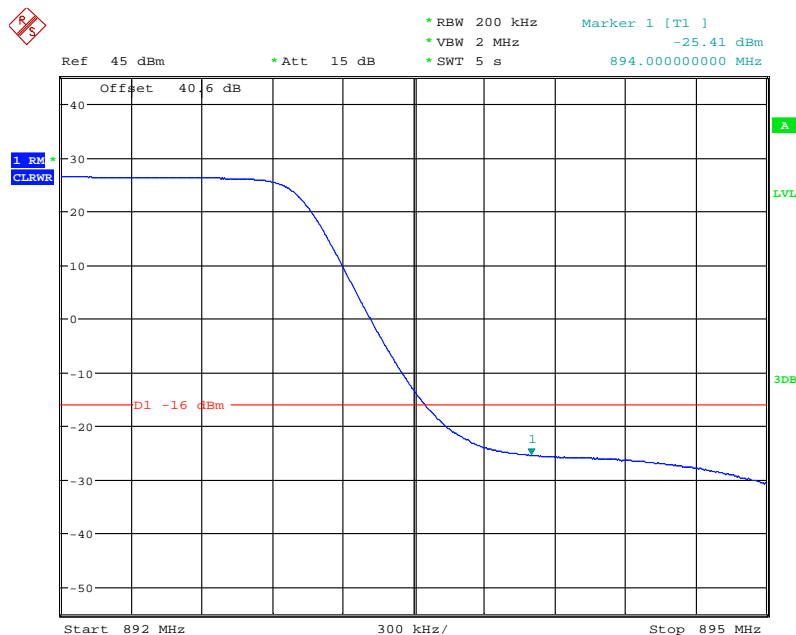

Date: 11.JUL.2013 15:17:44

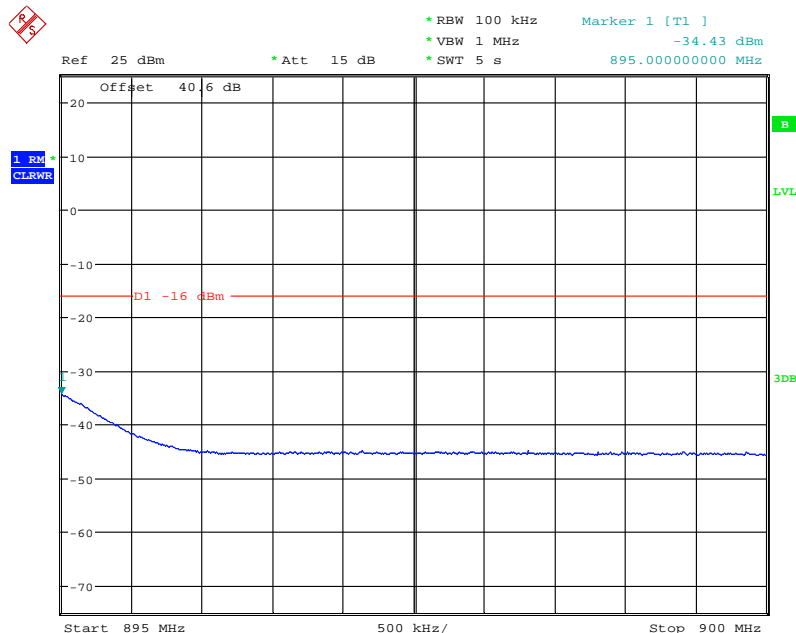

Date: 11.JUL.2013 15:17:04



Multi Carrier (x2)

E-TM1.1

1.4MHz Bandwidth

Configuration 1 - Mode 4' - 1.4

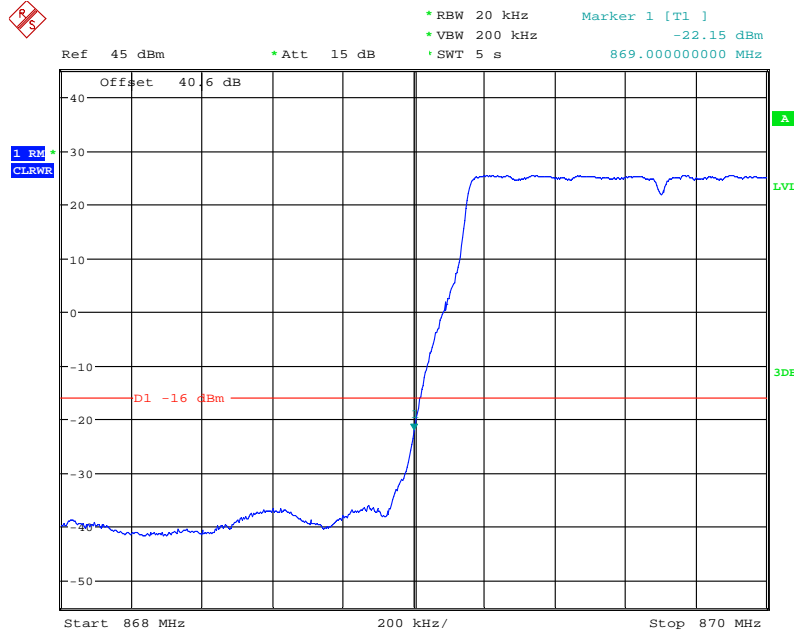

Date: 15.JUL.2013 10:47:03

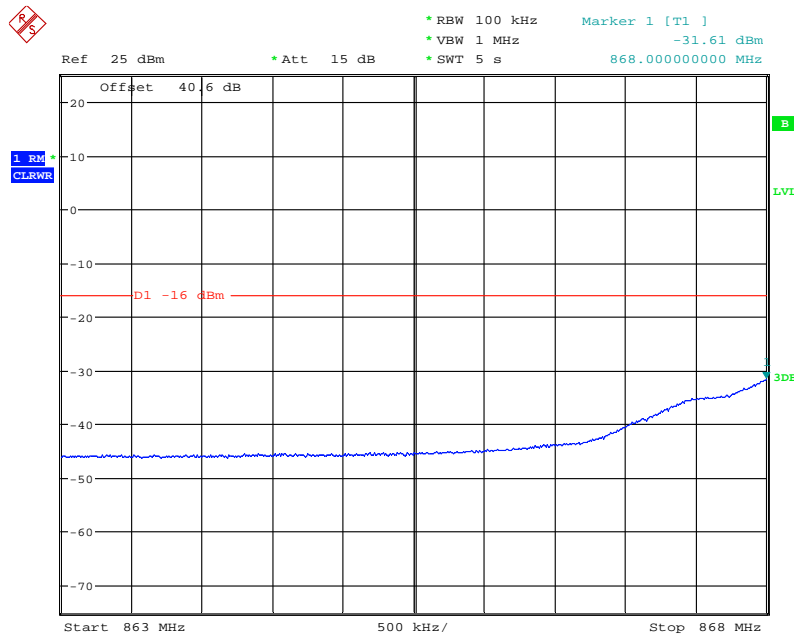

Date: 15.JUL.2013 10:49:17



Configuration 1 - Mode 6' - 1.4

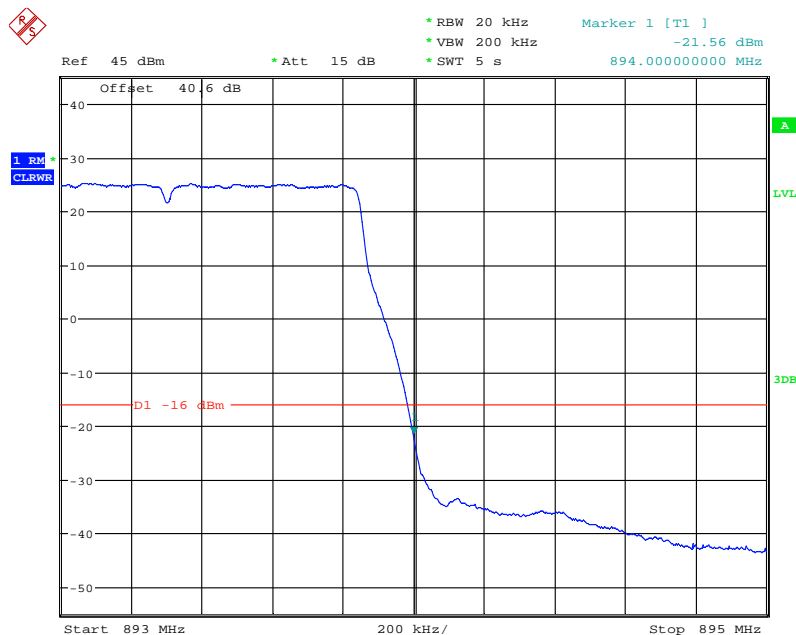

Date: 15.JUL.2013 10:58:57

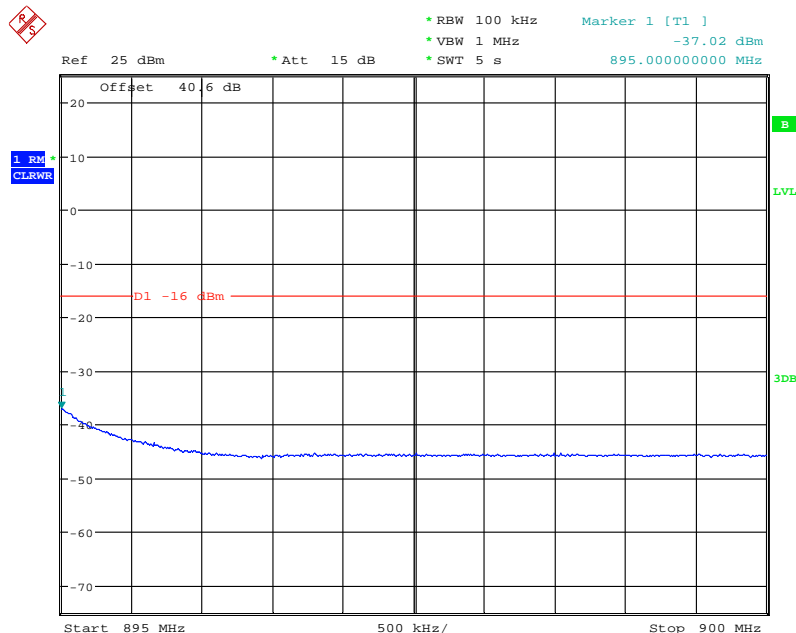

Date: 15.JUL.2013 10:58:31



3.0MHz Bandwidth

Configuration 1 - Mode 4' - 3

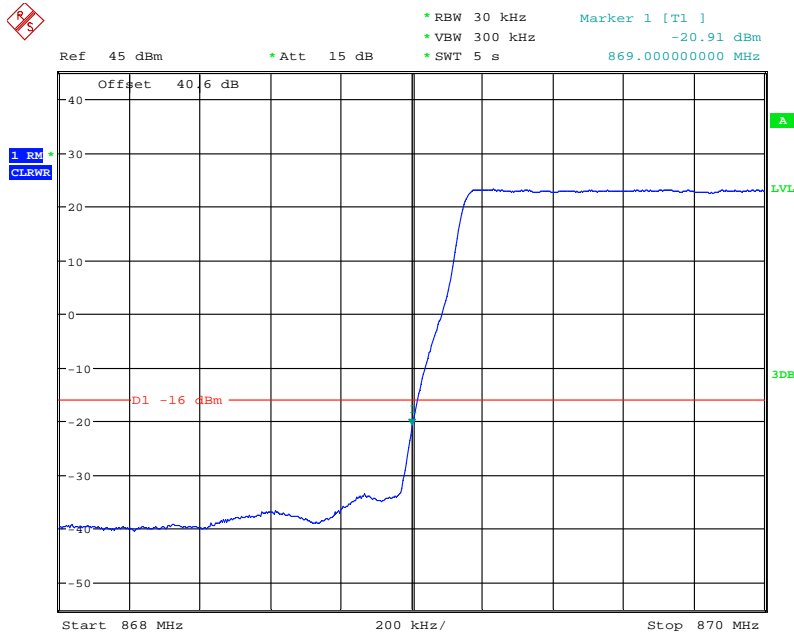

Date: 15.JUL.2013 11:27:46

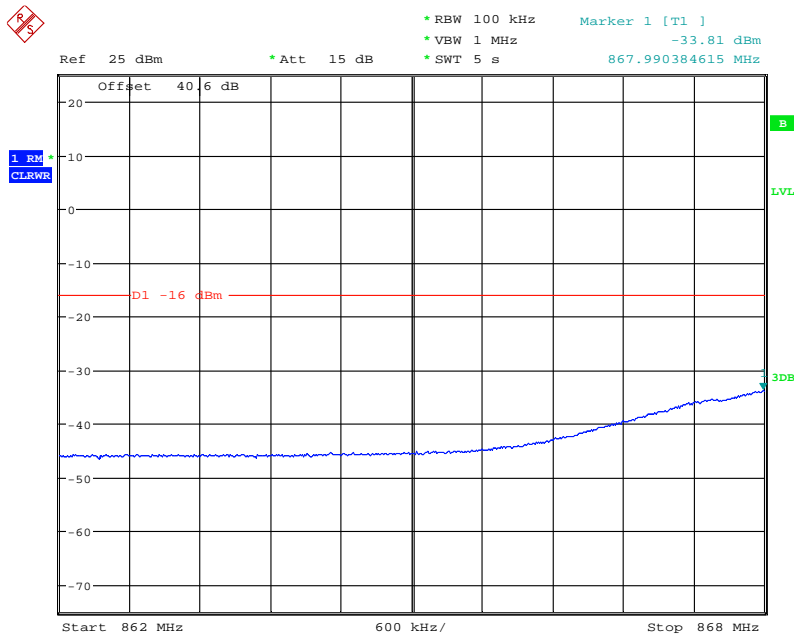

Date: 15.JUL.2013 11:27:13



Configuration 1 - Mode 6' - 3

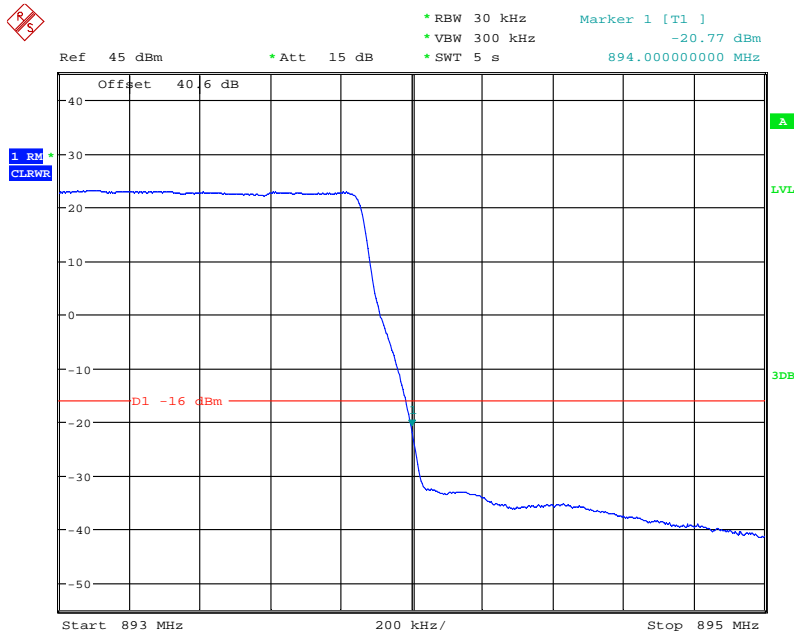

Date: 15.JUL.2013 11:13:30

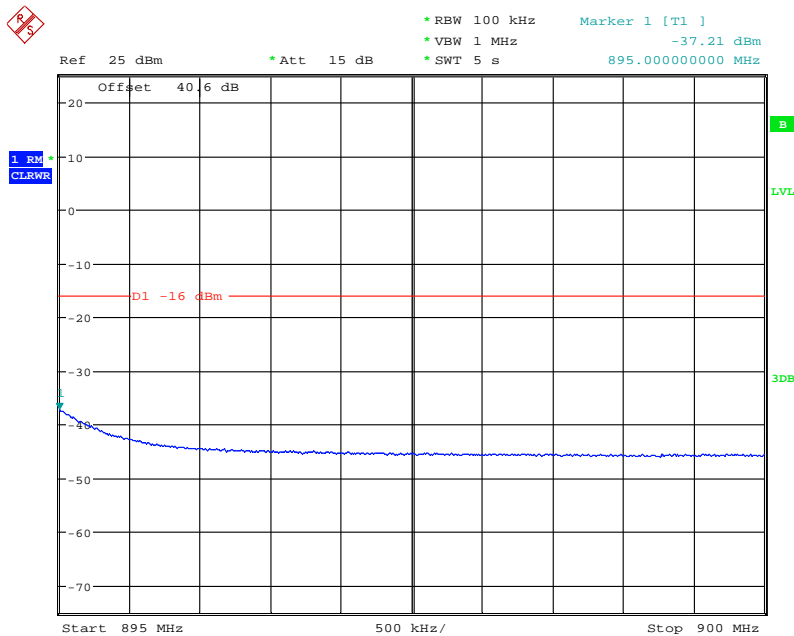

Date: 15.JUL.2013 11:13:55



5.0MHz Bandwidth

Configuration 1 - Mode 4' - 5

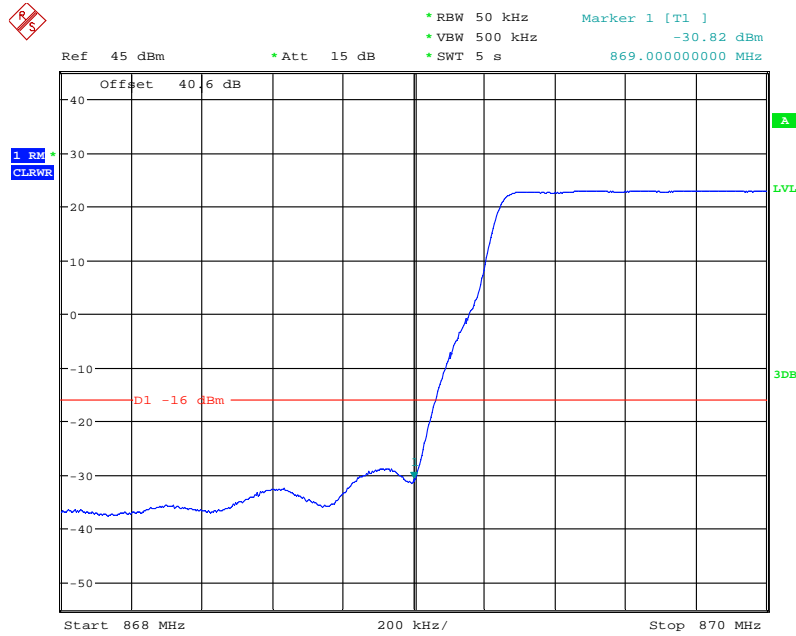

Date: 15.JUL.2013 11:40:26

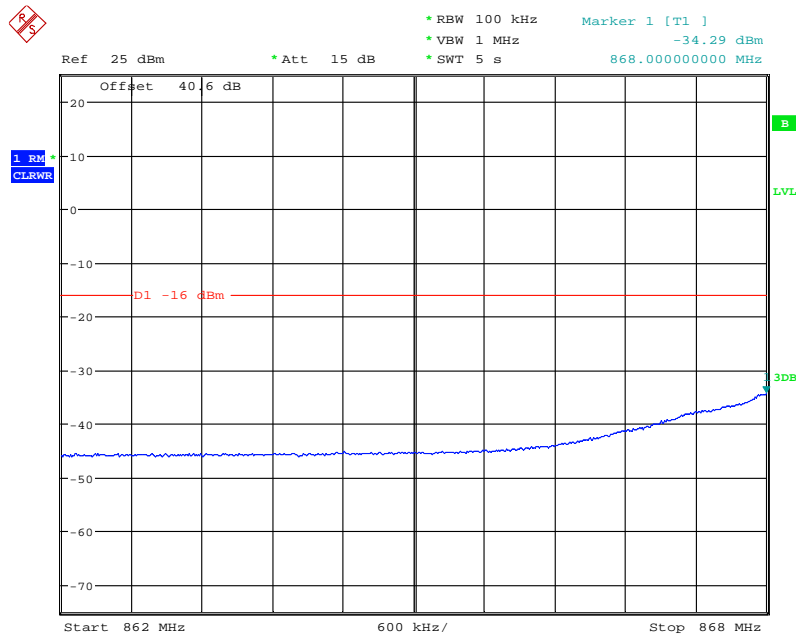

Date: 15.JUL.2013 11:40:57



Configuration 1 - Mode 6' - 5

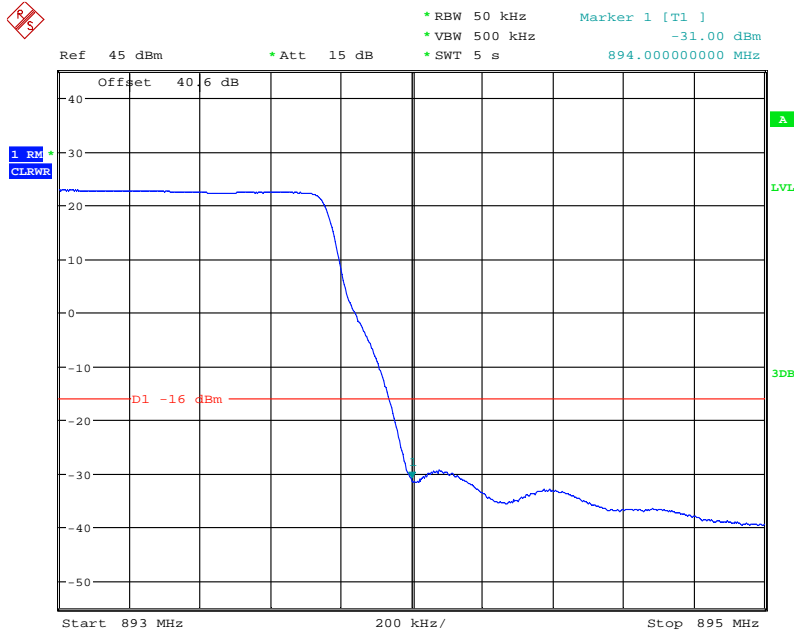

Date: 15.JUL.2013 11:42:59

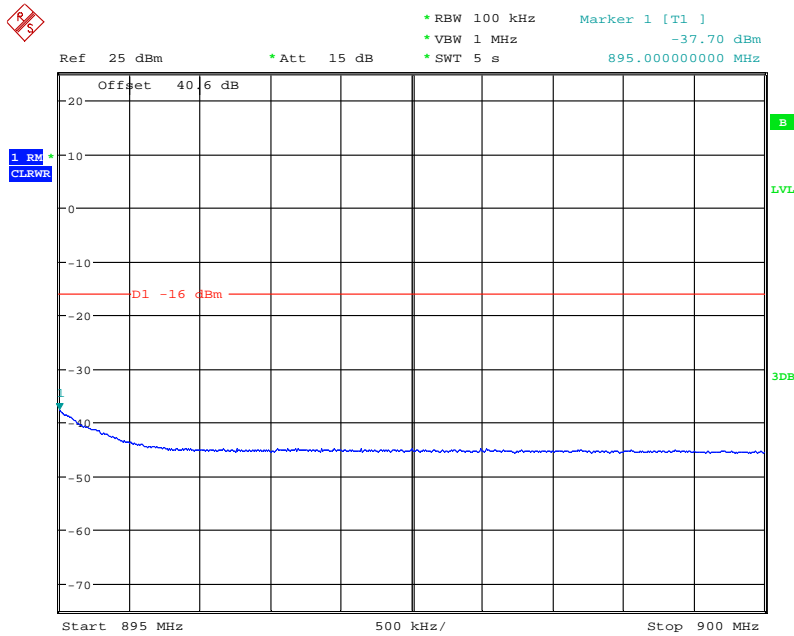

Date: 15.JUL.2013 11:43:28



10.0MHz Bandwidth

Configuration 1 - Mode 4 - 10

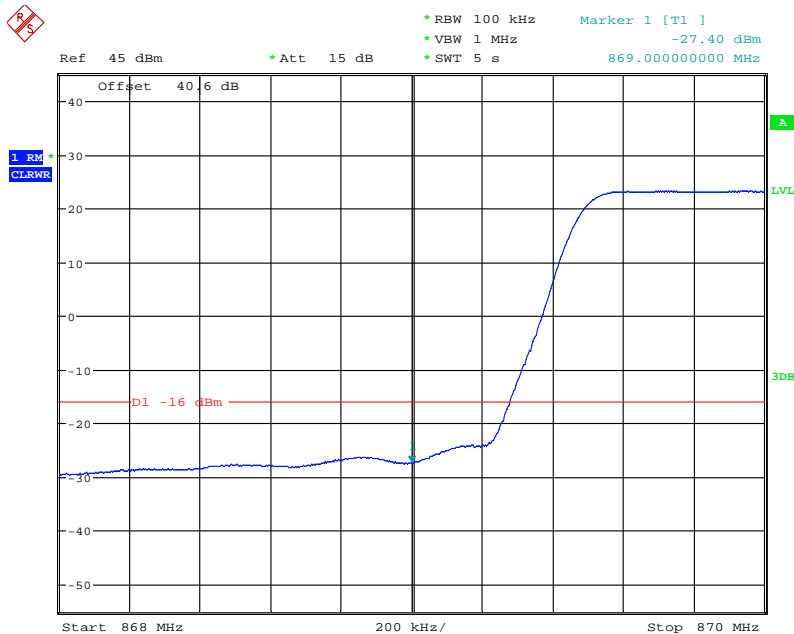

Date: 15.JUL.2013 11:48:42

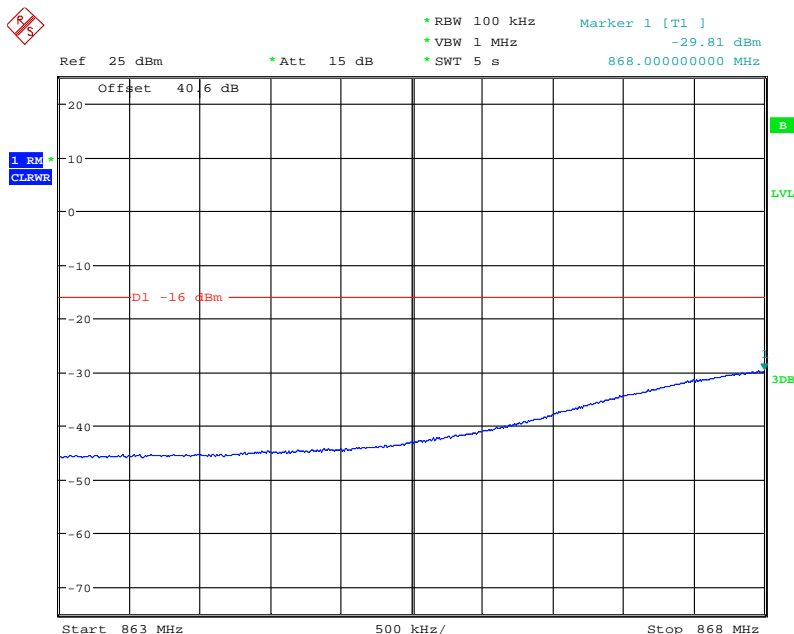

Date: 15.JUL.2013 11:49:10



Configuration 1 - Mode 6 - 10

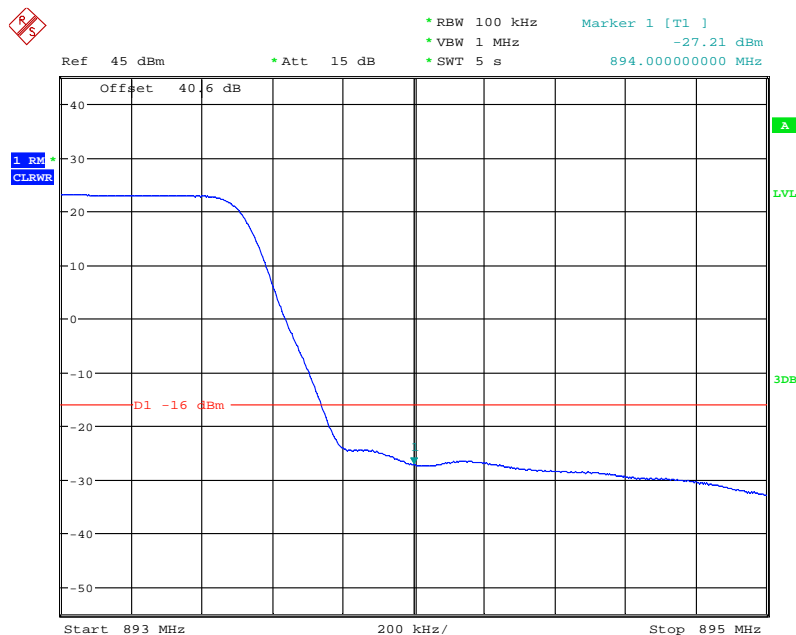

Date: 15.JUL.2013 11:45:49

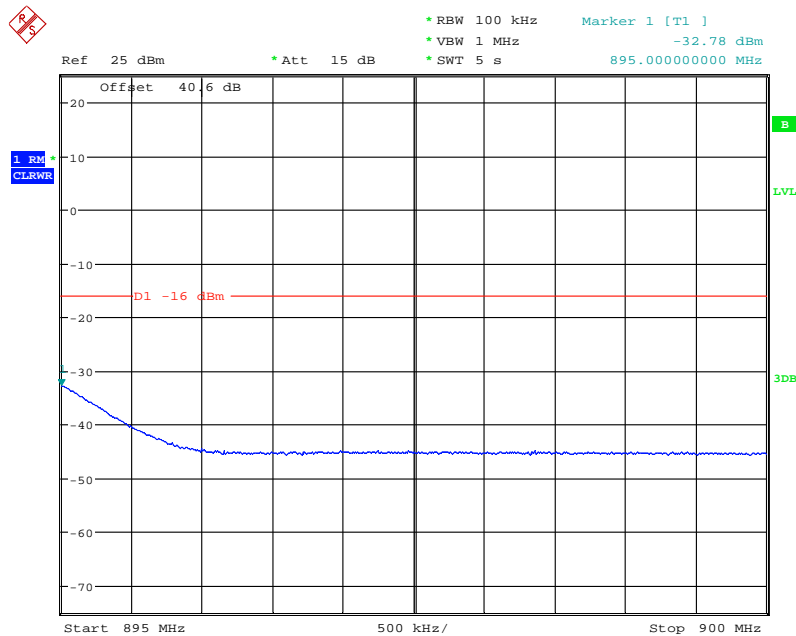

Date: 15.JUL.2013 11:45:01

Limit

The power of any emission outside the frequency band shall be attenuated below the transmitter power (P) by at least $43 + 10\log P$ dB + $10\log(NANT)$.



Product Service

2.6 RADIATED SPURIOUS EMISSIONS

2.6.1 Specification Reference

FCC CFR 47 Part 2, Clause 2.1053
FCC CFR 47 Part 22, Clause 22.917 (a)
Industry Canada RSS-132, Clause 5.5

2.6.2 Equipment Under Test

RRUS 11 B5 / KRC 161 285/2, S/N: CB4P587219

2.6.3 Date of Test and Modification State

13 and 14 August 2013 – Modification State 0

2.6.4 Test Equipment Used

The major items of test equipment used for the above tests are identified in Section 3.1.

2.6.5 Test Method and Operating Modes

The test was applied in accordance with the test method requirements of FCC CFR 47 Part 2 and Part 22 and Industry Canada RSS-132.

A preliminary profile of the Spurious Radiated Emissions was obtained by operating the EUT on a remotely controlled turntable within the chamber. Measurements of emissions from the EUT were obtained with the Measurement Antenna in both Horizontal and Vertical Polarizations.

Emissions identified within the range 30MHz – 10GHz were then formally measured using a Peak detector as the worst case.

In the frequency Range 30MHz – 10GHz, the measurement was performed with a resolution bandwidth of 1MHz as the worst case.

The measurements were performed at a 3m distance unless otherwise stated.

The limits for Spurious Emissions have been calculated, as shown below using the following formula:

Field Strength of Carrier - $(43 + 10\log(P))$ dB

Where:

Field Strength is measured in dB μ V/m

P is measured Transmitter Power in Watts



Determination of Spurious Emission Limit

As the EUT does not have an integral antenna, the field strength of the carrier has been calculated assuming that the power is to be fed to a half-wave tuned dipoles as per 2.1053 (a).

$$E_{(v/m)} = (30 \times G_i \times P_o)^{0.5} / d$$

Where G_i is the antenna gain of ideal half-wave dipoles,
 P_o is the power out of the transceiver in W,
 d is the measurement distance in meter.

Therefore at 3m measurement distance the field strength using the lowest transceiver output power would be:

$$E_{(v/m)} = (30 \times 1.64 \times 63.90)^{0.5} / 3 = 18.69V/m = 145.4dB\mu V/m$$

As per 22.917(a) the spurious emission must be attenuated by $43 + 10\log(P_o)$ dB this gives:

$$43 + 10\log(63.90) = 61.0dB$$

Therefore the limit at 3m measurement distance is:

$$145.4 - 61.0 = 84.4 \text{ dB}\mu V/m$$

This limit has been used to determine Pass or Fail for the harmonics measured and detailed in the following results.

The test was performed with the EUT operating on all modes in section 1.4.3 and record the result of the following configurations and modes of operation for worst case:

- Configuration 1 - Mode 1 - 1.4
 - Mode 2 (1.4MHz, 3.0MHz, 5.0MHz, 10.0MHz, 15.0MHz, 20.0MHz OBW)
 - Mode 3 - 1.4
 - Mode 5 - 1.4

2.6.6 Environmental Conditions

	13 August 2013	14 August 2013
Ambient Temperature	28.0°C	26.0°C
Relative Humidity	50.0%	52.0%



Product Service

2.6.7 Test Results

For the period of test the EUT met the requirements of FCC CFR 47 Part 2 & Part 22 and Industry Canada RSS-132 for Radiated Spurious Emissions.

The test results are shown below

Note: Only the worst case results plots have been included as other emissions are greater than 20dB below the limit. A set of plots have been included to show the measurement system noise floor.

Single Carrier

E-TM1.1

1.4MHz Bandwidth

Configuration 1 - Mode 2

No emissions were detected within 20dB of the limit.

3.0MHz Bandwidth

Configuration 1 - Mode 2

No emissions were detected within 20dB of the limit.

5.0MHz Bandwidth

Configuration 1 - Mode 2

No emissions were detected within 20dB of the limit.

10.0MHz Bandwidth

Configuration 1 - Mode 2

No emissions were detected within 20dB of the limit.

15.0MHz Bandwidth

Configuration 1 - Mode 2

No emissions were detected within 20dB of the limit.

20.0MHz Bandwidth

Configuration 1 - Mode 2

No emissions were detected within 20dB of the limit.



Product Service

E-TM3.2

1.4MHz Bandwidth

Configuration 1 - Mode 1

No emissions were detected within 20dB of the limit.

Configuration 1 - Mode 2

30MHz – 1GHz

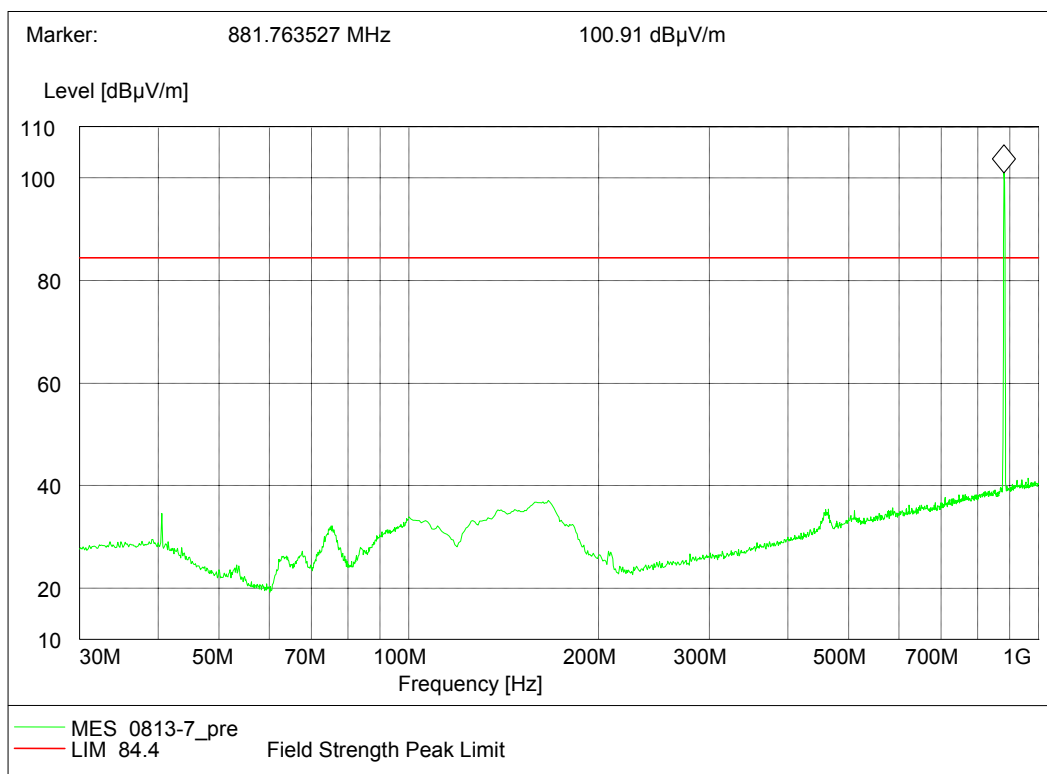

Note: The emission beyond the limit is the operating frequency.



1GHz – 3GHz

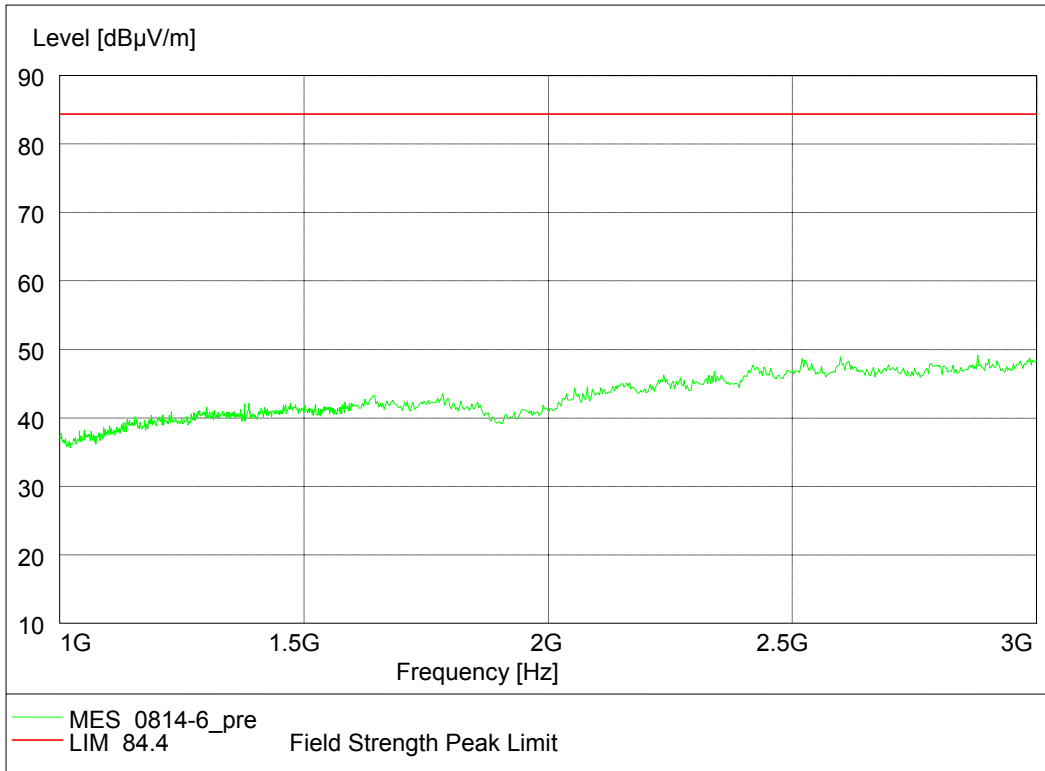

3GHz – 10GHz

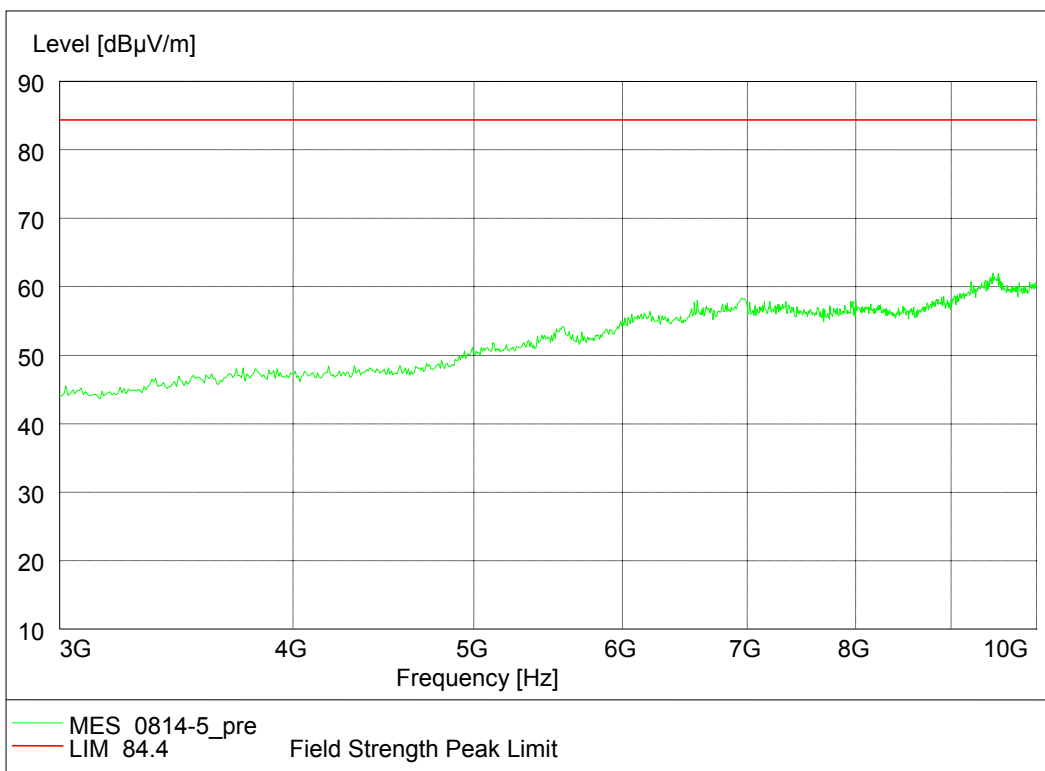



Product Service

Configuration 1 - Mode 3

No emissions were detected within 20dB of the limit.

E-TM3.1

1.4MHz Bandwidth

Configuration 1 - Mode 2

No emissions were detected within 20dB of the limit.

Multi Carrier (x2)

E-TM1.1

1.4MHz Bandwidth

Configuration 1 - Mode 5

No emissions were detected within 20dB of the limit.

Limit	-13dBm / 84.4dB μ V/m
-------	---------------------------

Remarks

The EUT does not exceed -13dBm / 84.4dB μ V/m at the measured frequencies.



2.7 CONDUCTED SPURIOUS EMISSIONS

2.7.1 Specification Reference

FCC CFR 47 Part 2, Clause 2.1051
 FCC CFR 47 Part 22, Clause 22.917 (a)
 Industry Canada RSS-132, Clause 5.5

2.7.2 Equipment Under Test

RRUS 11 B5 / KRC 161 285/2, S/N: CB4P587217

2.7.3 Date of Test and Modification State

11, 15 and 16 July 2013 – Modification State 0

2.7.4 Test Equipment Used

The major items of test equipment used for the above tests are identified in Section 3.1.

2.7.5 Test Method and Operating Modes

The test was applied in accordance with the test method requirements of FCC CFR 47 Part 2 and Part 22 and Industry Canada RSS-132.

In accordance with Part 2.1051, the spurious emissions from the antenna terminal were measured. The measurements were performed on the output connector RF A. Limited complementary measurement were done at output connector RF B to verify identical performance for both transmitter chains. The EUT was set to transmit on maximum power. The transmitter output was attenuated using an attenuator and the frequency spectrum investigated from 9kHz to 10GHz. The EUT was tested on Bottom, Middle and Top channels for E-TM1.1 test model, just 1.4MHz and 20MHz bandwidth for single carrier and 1.4MHz and 10MHz bandwidth for multi carrier configurations were selected as the representative modes,. The resolution was set to 100kHz for 9kHz to 10GHz thus meeting the requirements of FCC CFR 47 Part 22, Clause 22.917 (b) and Industry Canada RSS-132, Clause 5.5. The spectrum analyser detector was set to peak and trace was kept on Max Hold as worst case.

The limit was adjusted with a correction of -3dB [10Log(2)] by using the Measure and Add 10Log(N) dB technique according to FCC KDB662911 D01 accounting for simultaneous transmission from antenna ports RF A and RF B.

The maximum path loss across the measurement band was used as the reference level offset to ensure worst case.

Measurements were made up to the 10th harmonic of the highest carrier frequency at least.

The test was performed with the EUT in the following configurations and modes of operation:

- Configuration 1 - Mode 1 - 1.4, Mode 1 - 20
- Mode 2 (1.4MHz, 20.0MHz OBW)
- Mode 3 - 1.4, Mode 3 - 20
- Mode 4 - 1.4, Mode 4 - 10
- Mode 5 - 1.4, Mode 5 - 10
- Mode 6 - 1.4, Mode 6 - 10



Product Service

2.7.6 Environmental Conditions

	11 July 2013	15 July 2013	16 July 2013
Ambient Temperature	22.0°C	23.0°C	22.5°C
Relative Humidity	61.0%	64.5%	60.0%

2.7.7 Test Results

For the period of test the EUT met the requirements of FCC CFR 47 Part 2 and Part 22 and Industry Canada RSS-132 for Conducted Spurious Emissions.

The test results are shown below

Remark:

The emissions at 9kHz on the plots was not generated by the test object. A complementary measruement with a smaller Span showed that it was related to the LO feedthrough.

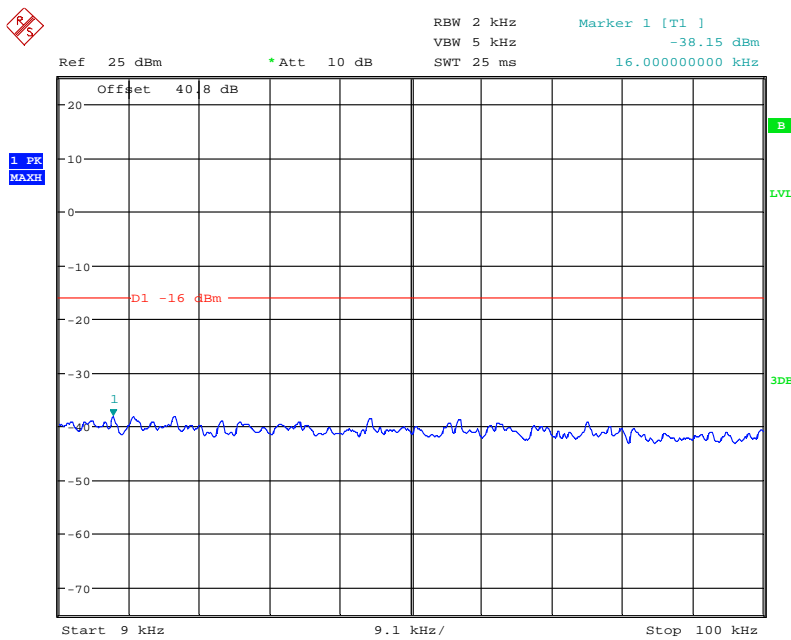

Date: 11.JUL.2013 10:08:26



Product Service

Single Carrier

E-TM1.1 - 1.4MHz Bandwidth

Configuration 1 - Mode 1 - 1.4

9kHz to 1.1GHz

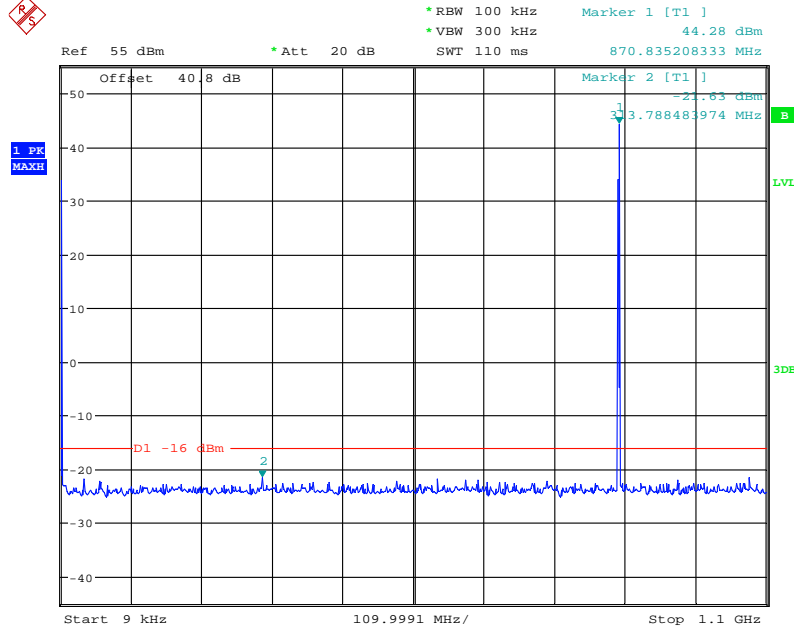

Date: 11.JUL.2013 16:24:35

Note: The emission beyond the limit is the operating frequency.

1.1GHz to 4GHz

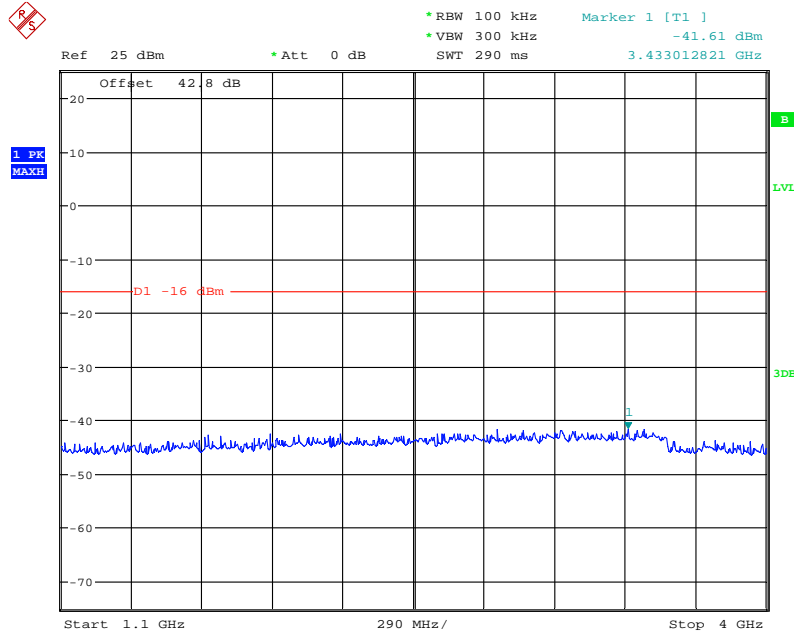

Date: 11.JUL.2013 16:25:38



4GHz to 10GHz

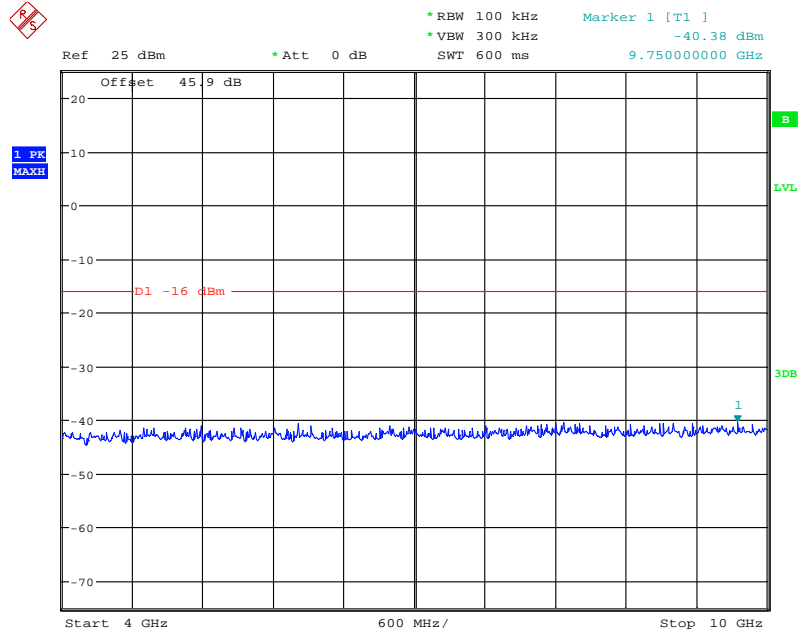

Date: 11.JUL.2013 16:22:25

Configuration 1 - Mode 2 - 1.4

9kHz to 1.1GHz

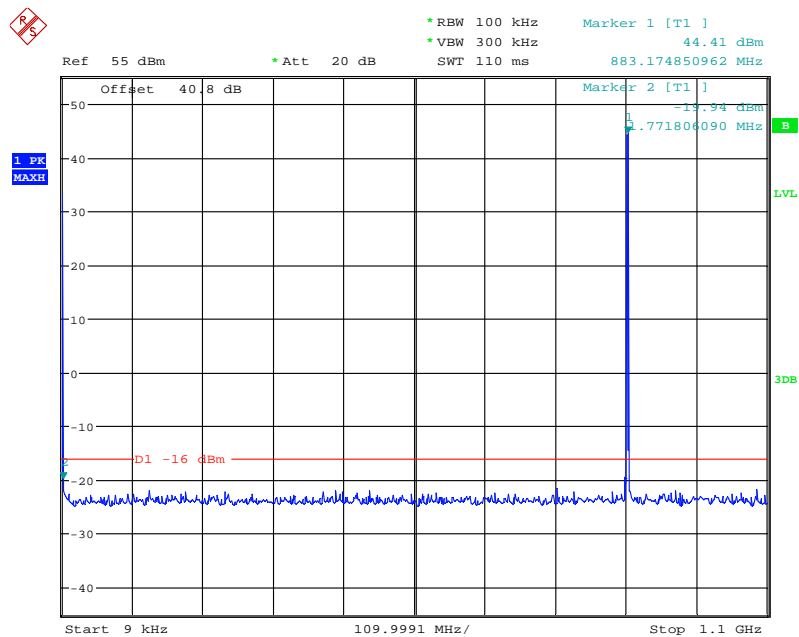

Date: 11.JUL.2013 11:33:02

Note: The emission beyond the limit is the operating frequency.



1.1GHz to 4GHz

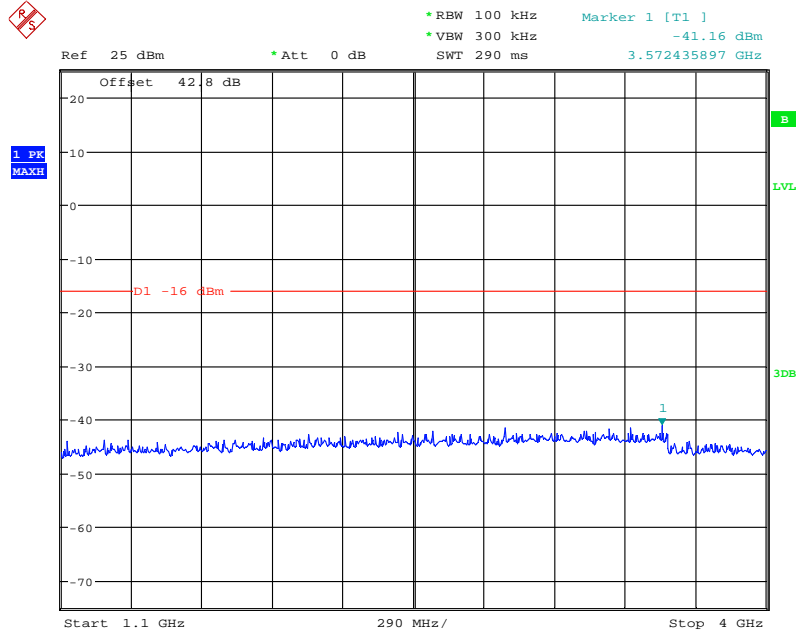

Date: 11.JUL.2013 10:07:23

4GHz to 10GHz

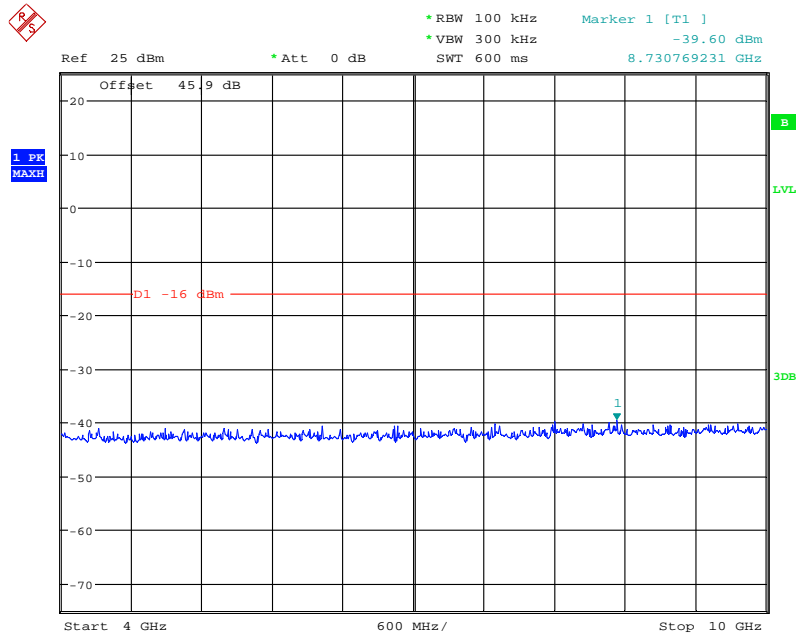

Date: 11.JUL.2013 10:00:45



Configuration 1 - Mode 3 - 1.4

9kHz to 1.1GHz

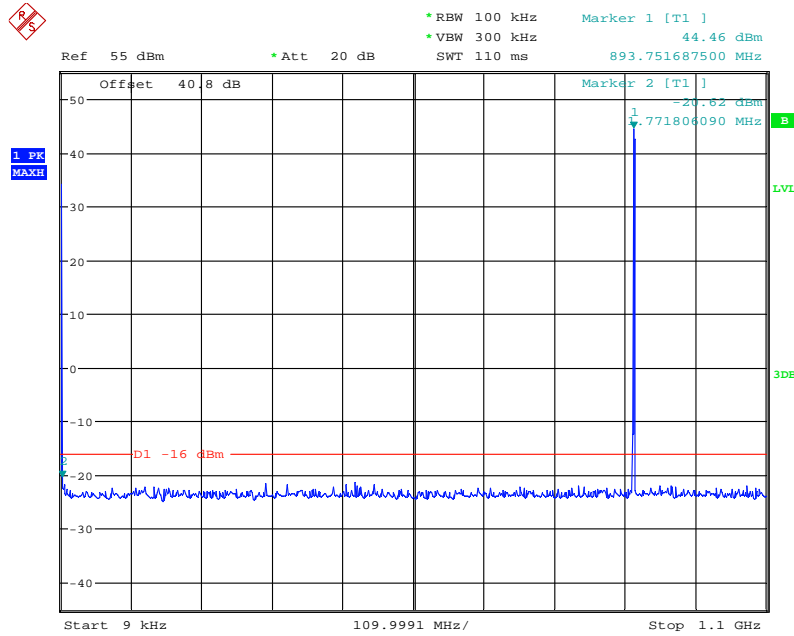

Date: 11.JUL.2013 15:56:01

Note: The emission beyond the limit is the operating frequency.

1.1GHz to 4GHz

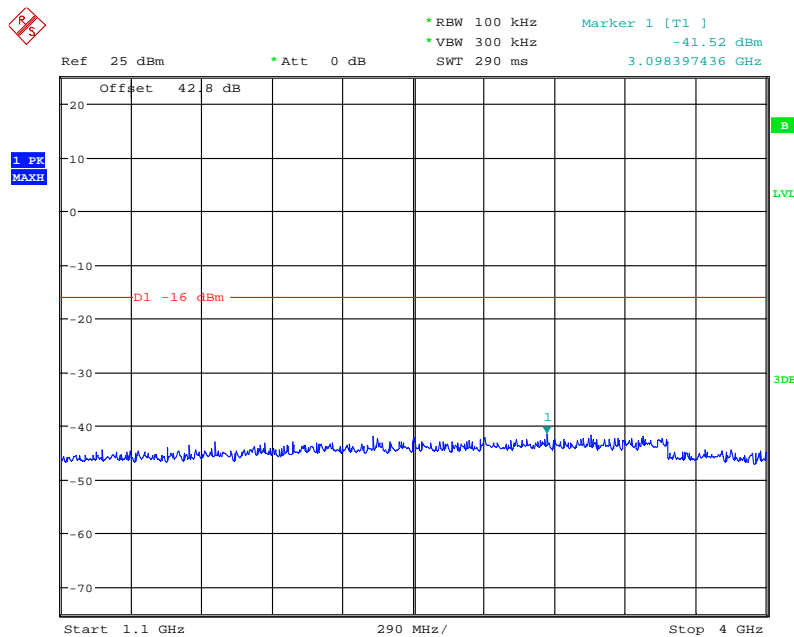

Date: 11.JUL.2013 16:00:52



4GHz to 10GHz

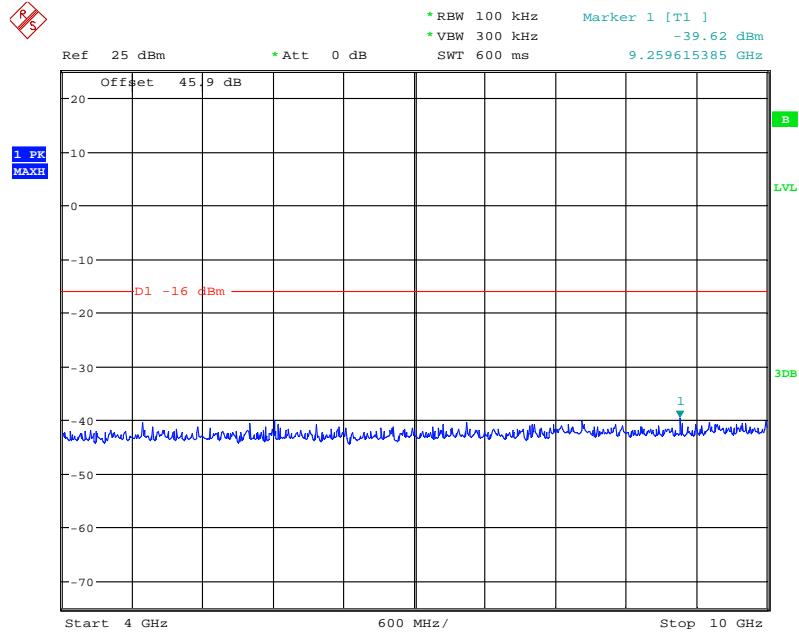

Date: 11.JUL.2013 15:57:02

E-TM1.1 - 20MHz Bandwidth

Configuration 1 - Mode 1 – 20

9kHz to 1.1GHz

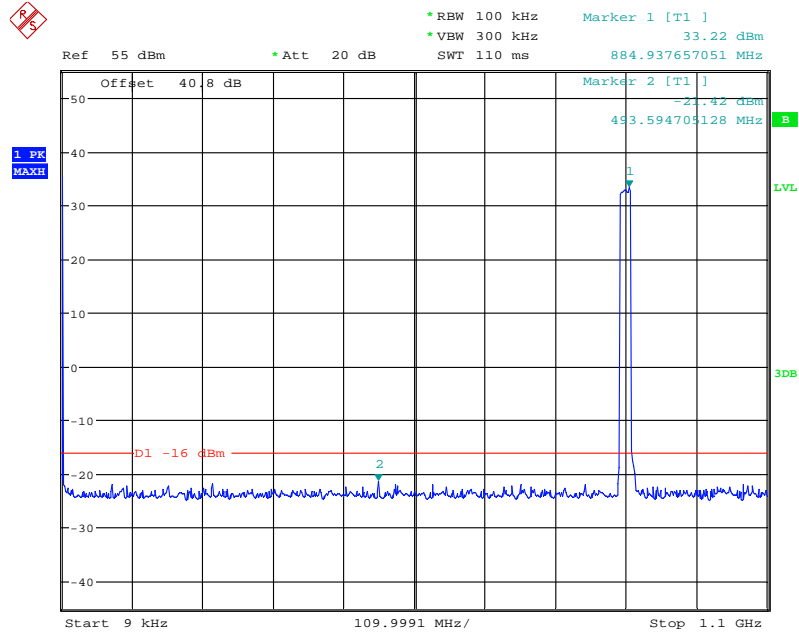

Date: 11.JUL.2013 16:33:44

Note: The emission beyond the limit is the operating frequency.



1.1GHz to 4GHz

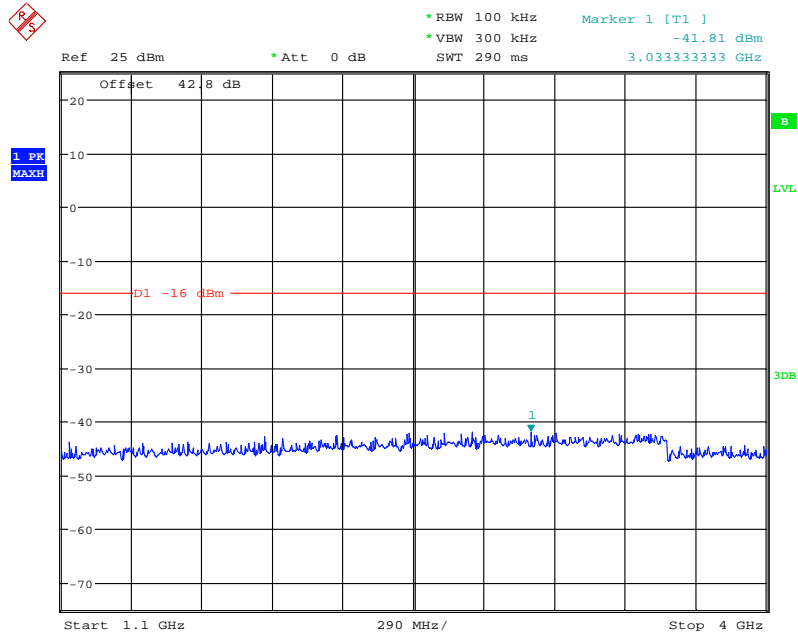

Date: 11.JUL.2013 16:43:09

4GHz to 10GHz

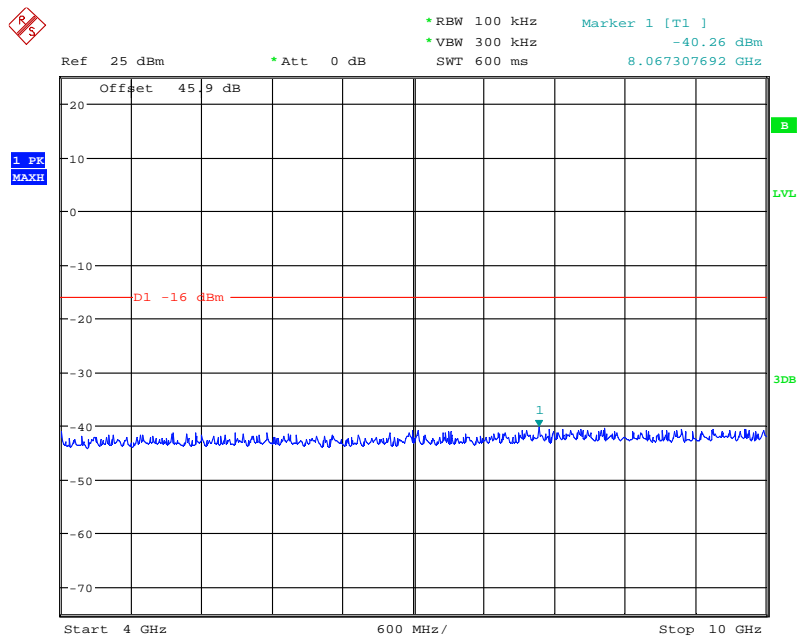

Date: 11.JUL.2013 16:32:33



Product Service

Configuration 1 - Mode 2 - 20

9kHz to 1.1GHz

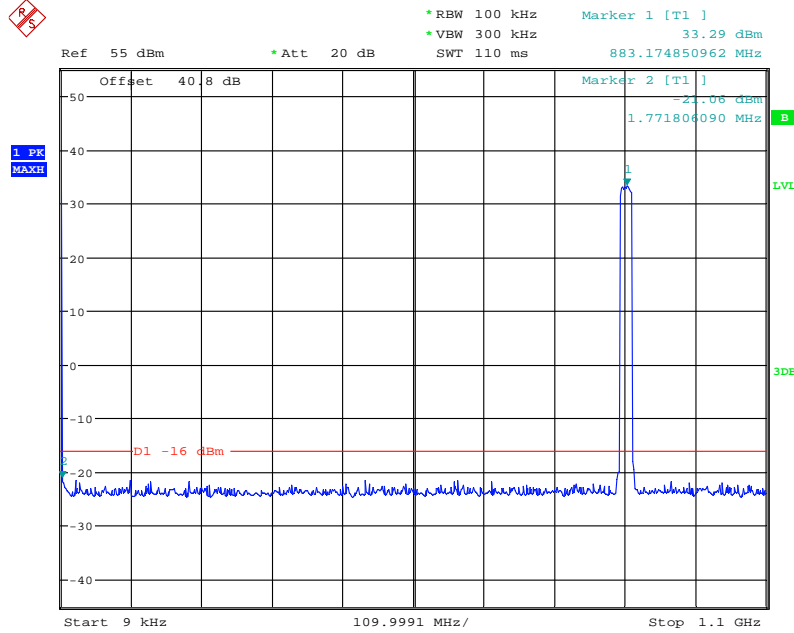

Date: 11.JUL.2013 11:35:45

Note: The emission beyond the limit is the operating frequency.

1.1GHz to 4GHz

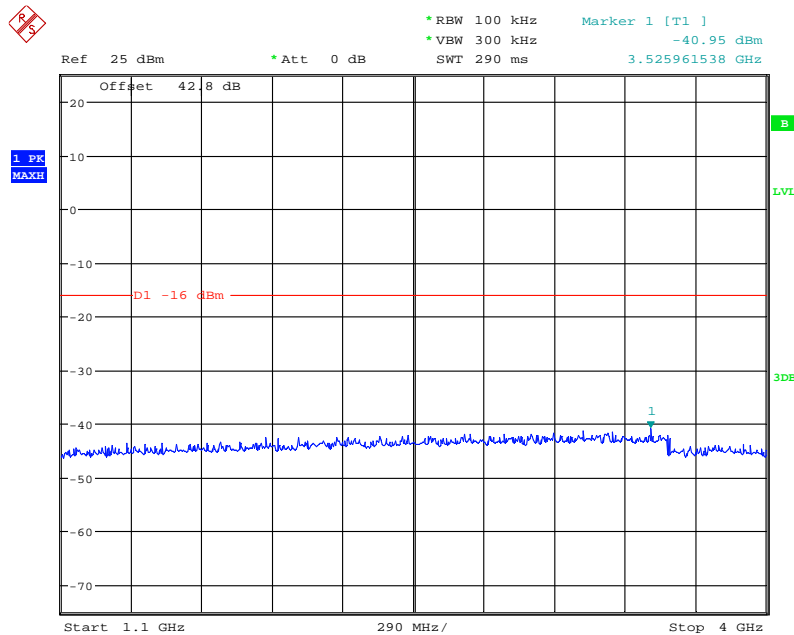

Date: 11.JUL.2013 11:06:19



4GHz to 10GHz

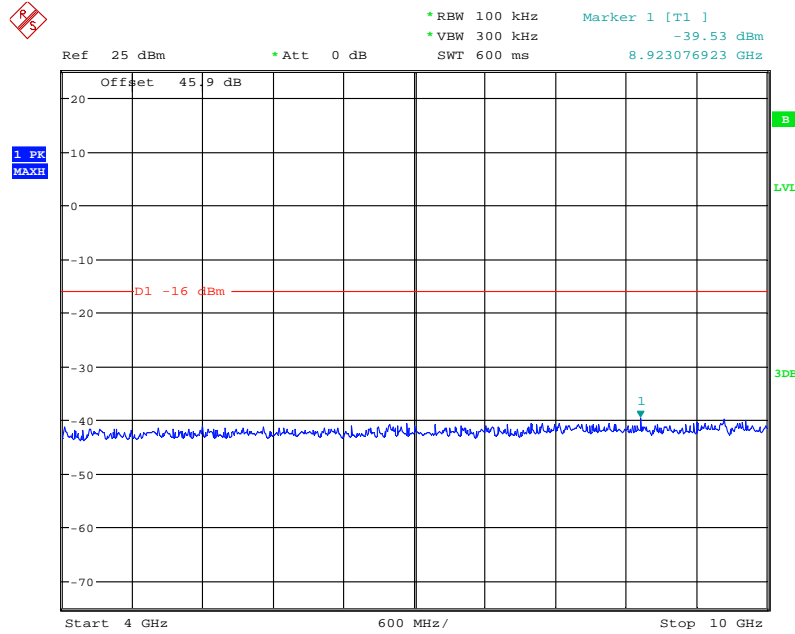

Date: 11.JUL.2013 11:03:01

Configuration 1 - Mode 3 - 20

9kHz to 1.1GHz

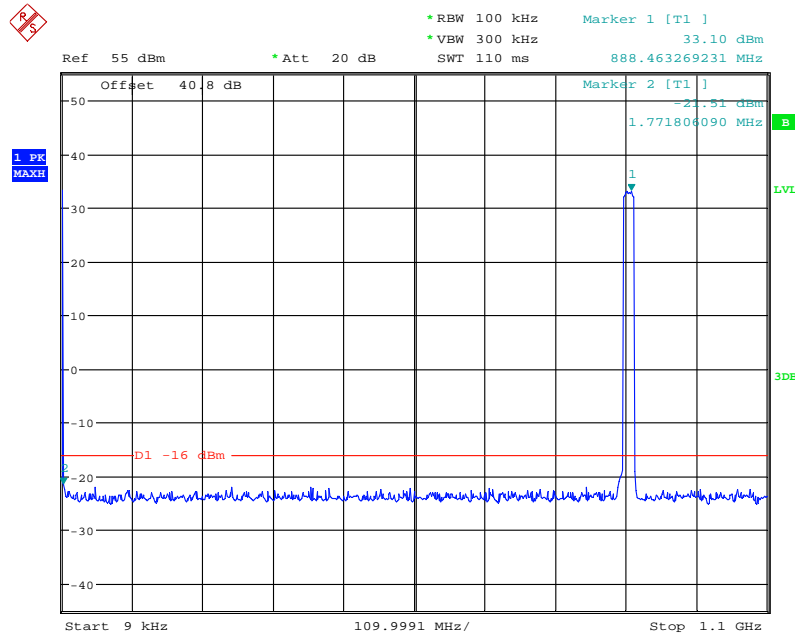

Date: 11.JUL.2013 17:20:02

Note: The emission beyond the limit is the operating frequency.



1.1GHz to 4GHz

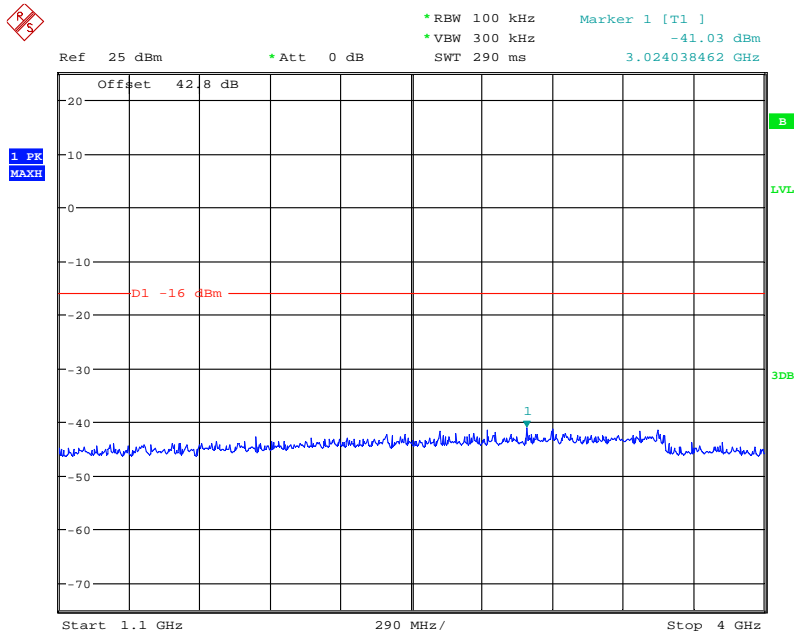

Date: 11.JUL.2013 17:03:03

4GHz to 10GHz

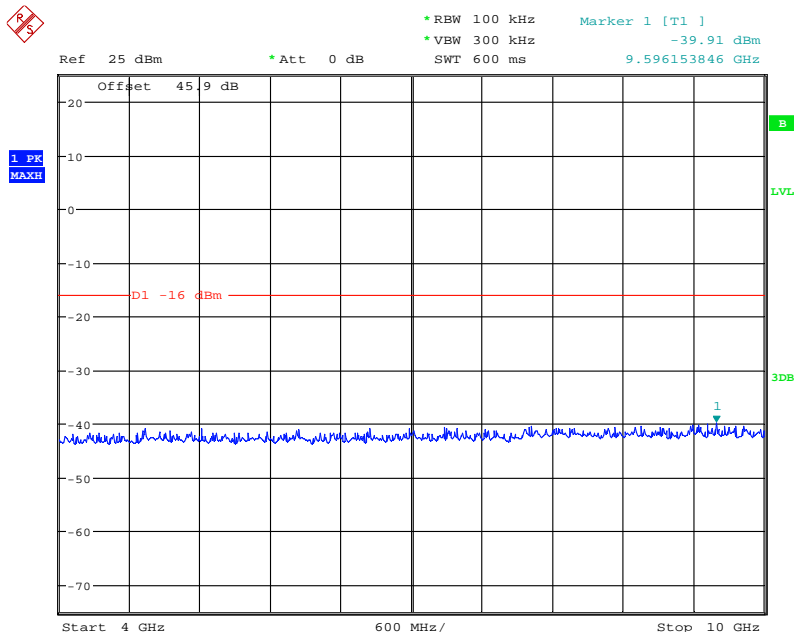

Date: 11.JUL.2013 17:21:50



Product Service

Multi Carrier (x2)

E-TM1.1 - 1.4MHz Bandwidth

Configuration 1 - Mode 4 - 1.4

9kHz to 1.1GHz

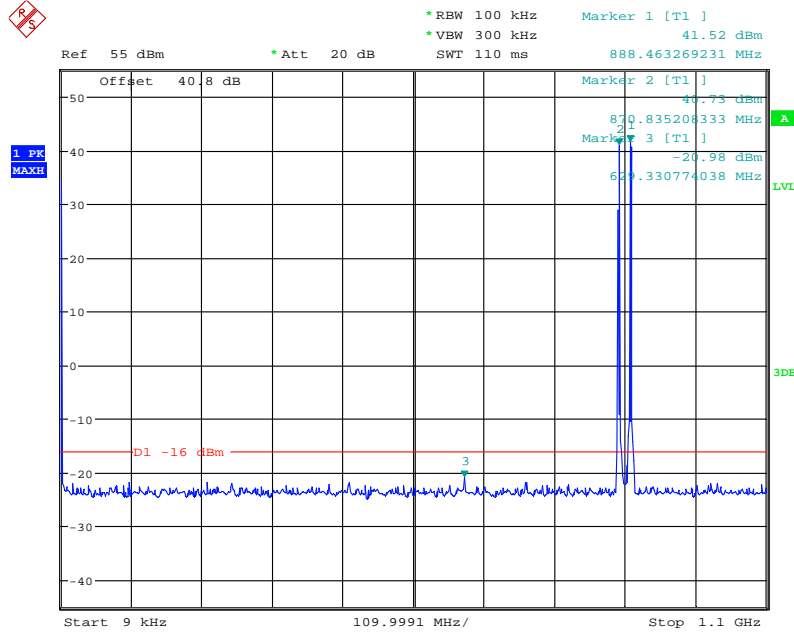

Date: 16.JUL.2013 11:21:11

Note: The emission beyond the limit is the operating frequency.
1.1GHz to 4GHz

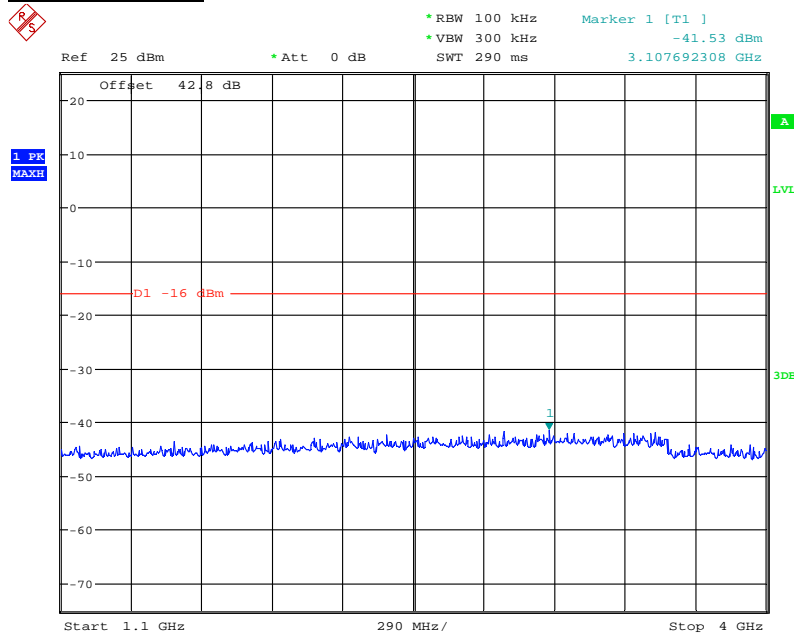

Date: 16.JUL.2013 11:24:00



4GHz to 10GHz

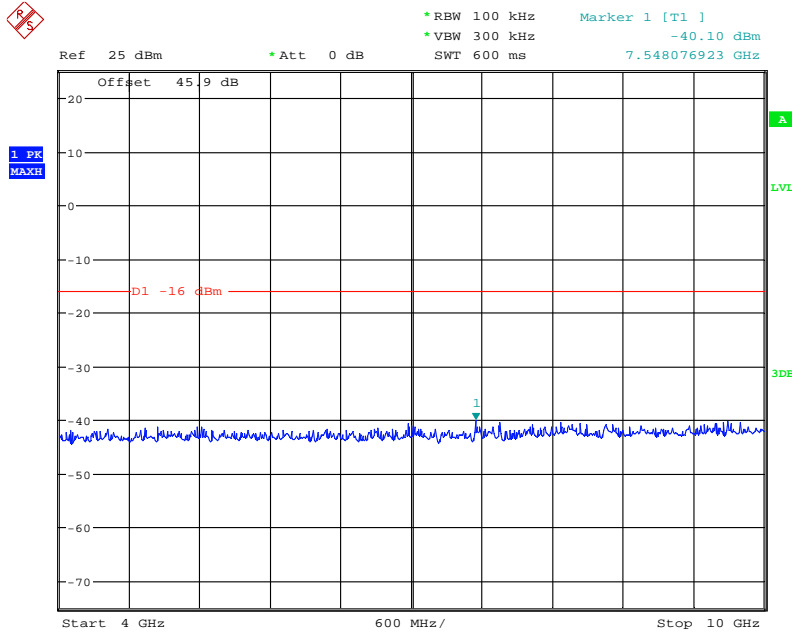

Date: 16.JUL.2013 11:22:49

Configuration 1 - Mode 5 - 1.4

9kHz to 1.1GHz

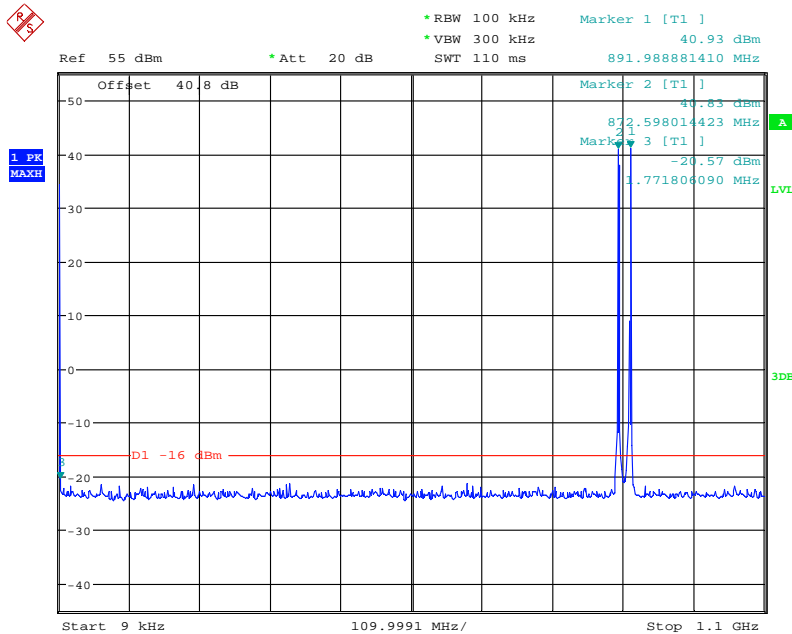

Date: 16.JUL.2013 11:42:53

Note: The emission beyond the limit is the operating frequency.



1.1GHz to 4GHz

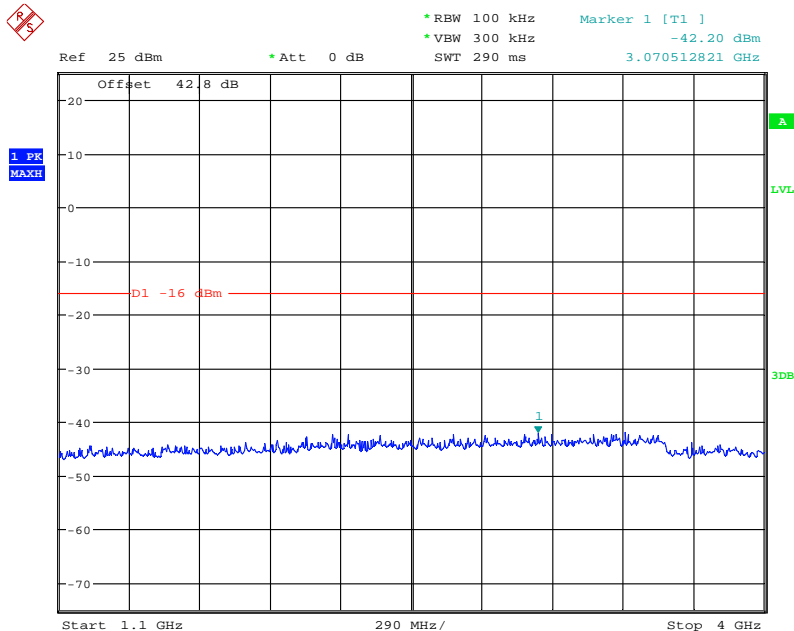

Date: 16.JUL.2013 11:40:08

4GHz to 10GHz

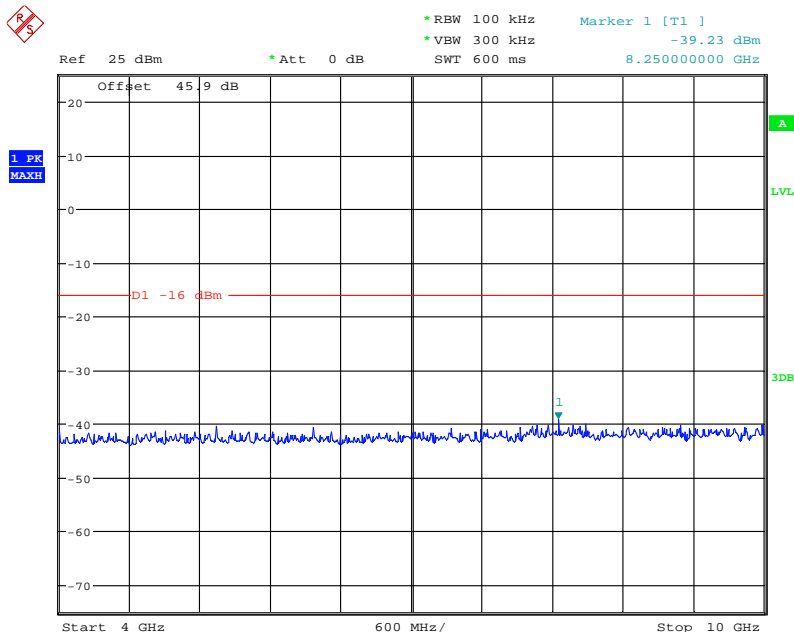

Date: 16.JUL.2013 11:41:17



Configuration 1 - Mode 6 - 1.4

9kHz to 1.1GHz

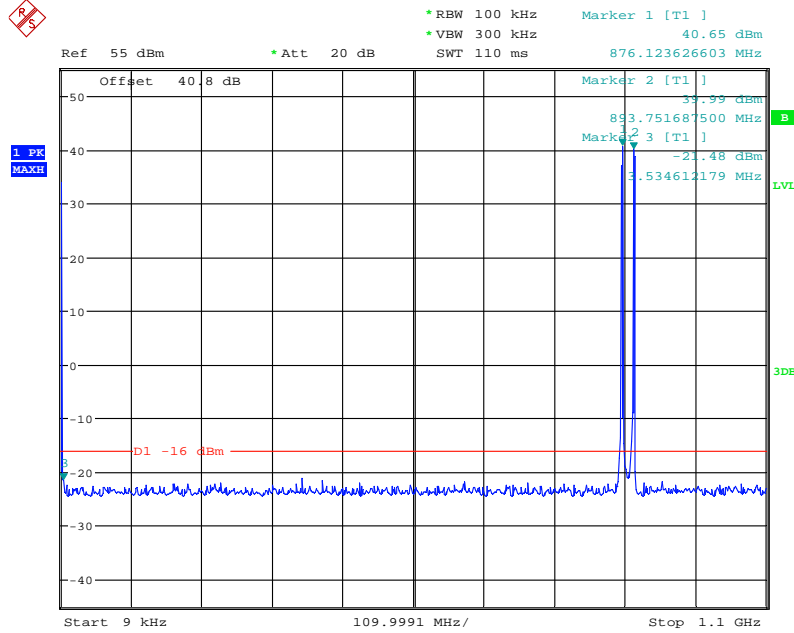

Date: 16.JUL.2013 12:02:25

Note: The emission beyond the limit is the operating frequency.

1.1GHz to 4GHz

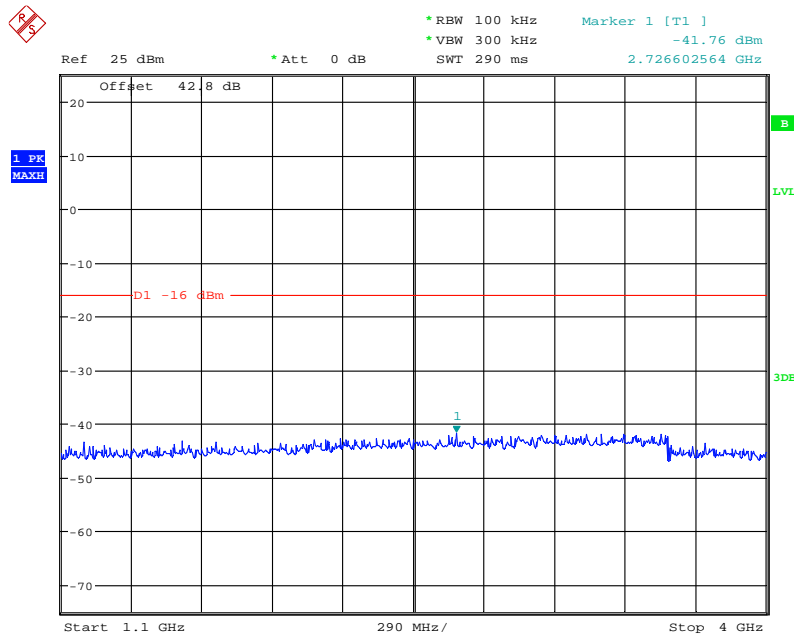

Date: 16.JUL.2013 12:06:29



4GHz to 10GHz

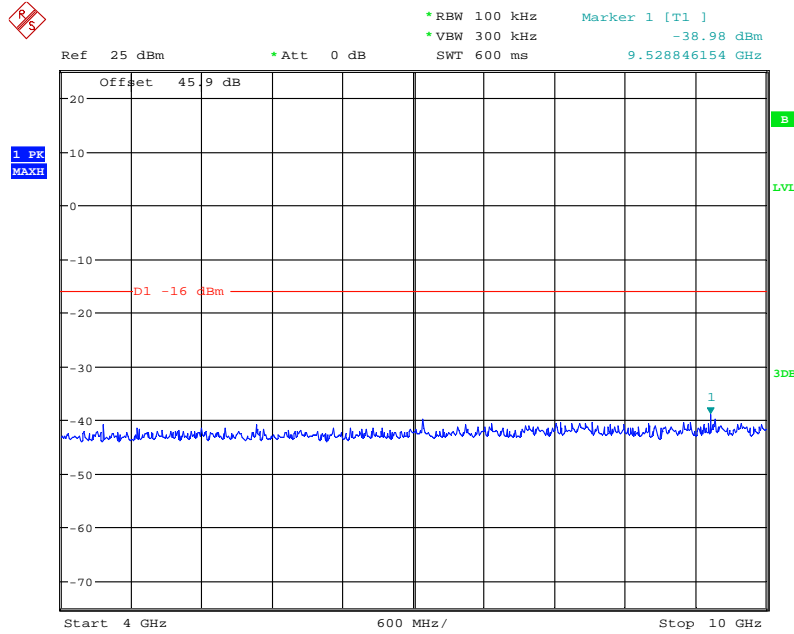

Date: 16.JUL.2013 12:04:11

E-TM1.1 - 10MHz Bandwidth

Configuration 1 - Mode 4 – 10

9kHz to 1.1GHz

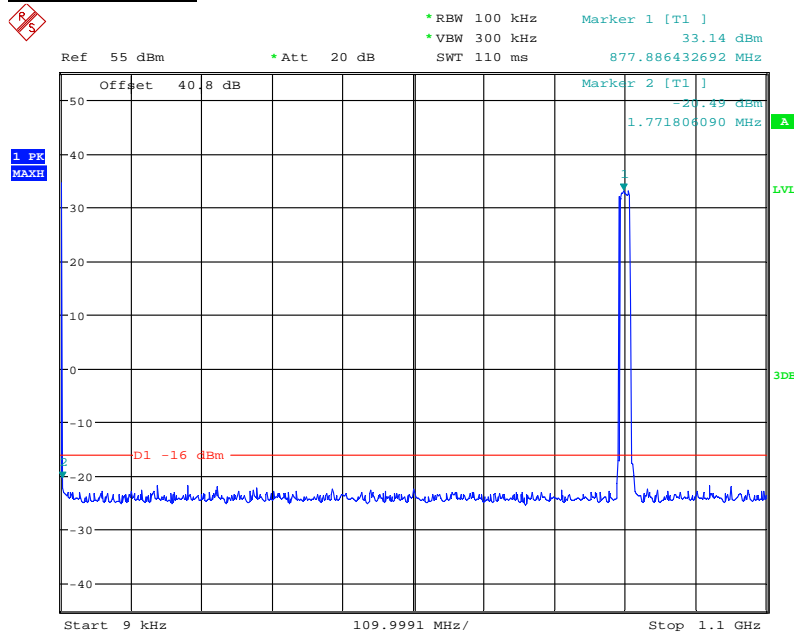

Date: 15.JUL.2013 15:50:51

Note: The emission beyond the limit is the operating frequency.



1.1GHz to 4GHz

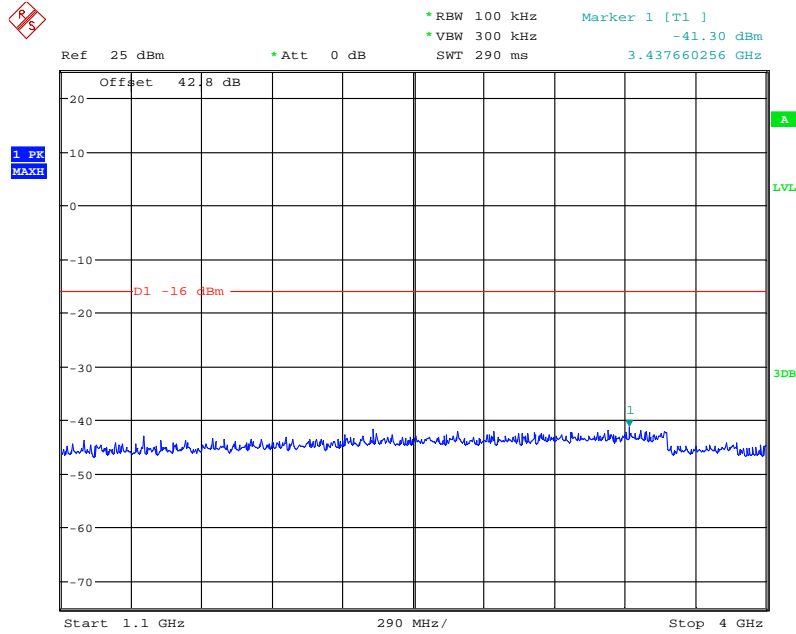

Date: 15.JUL.2013 15:54:40

4GHz to 10GHz

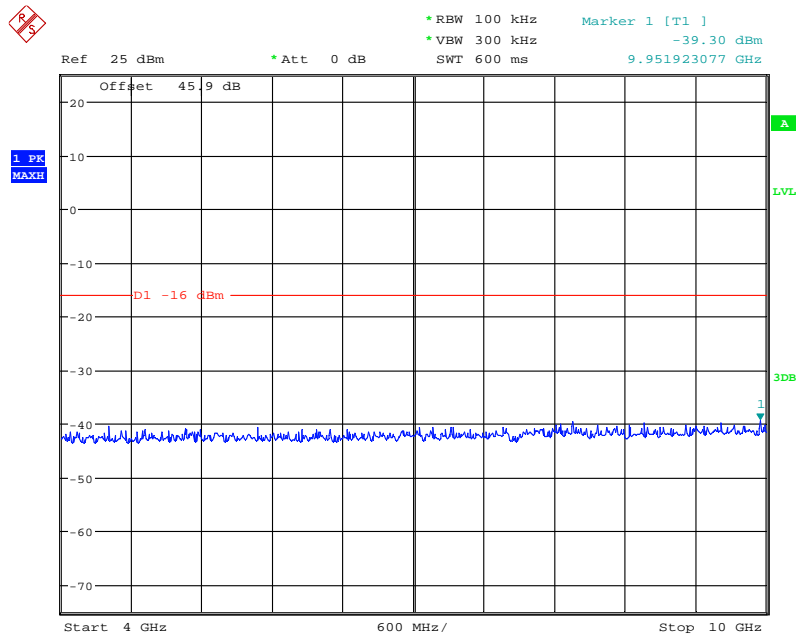

Date: 15.JUL.2013 15:52:44



Configuration 1 - Mode 5 - 10

9kHz to 1.1GHz

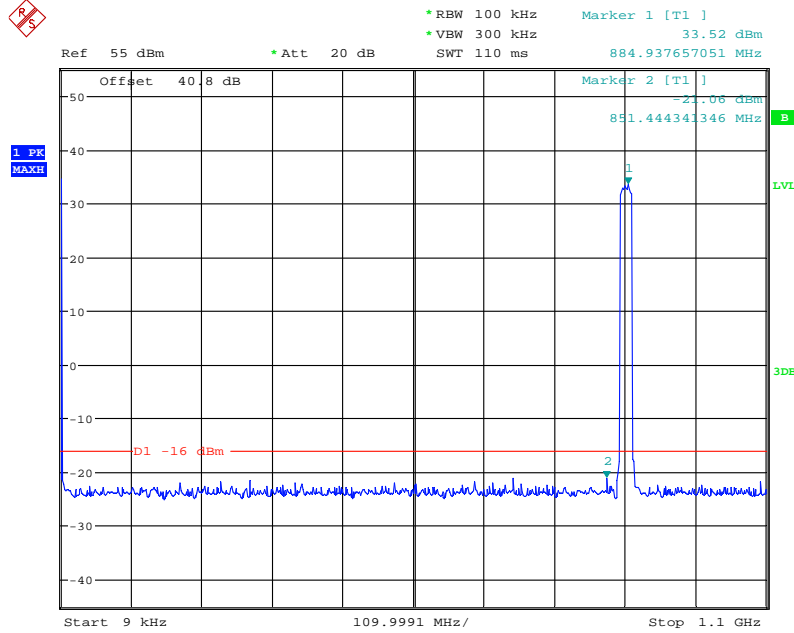

Date: 15.JUL.2013 13:50:04

Note: The emission beyond the limit is the operating frequency.

1.1GHz to 4GHz

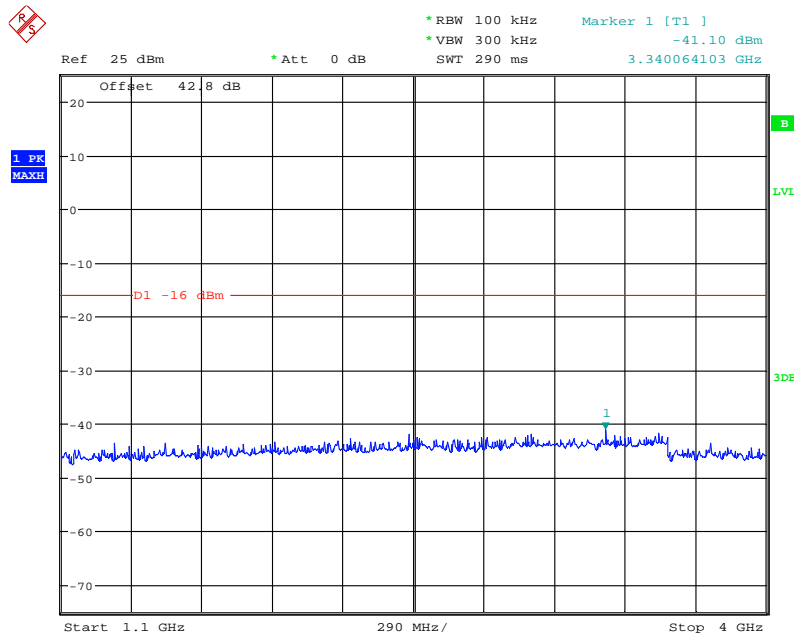

Date: 15.JUL.2013 13:47:43



4GHz to 10GHz

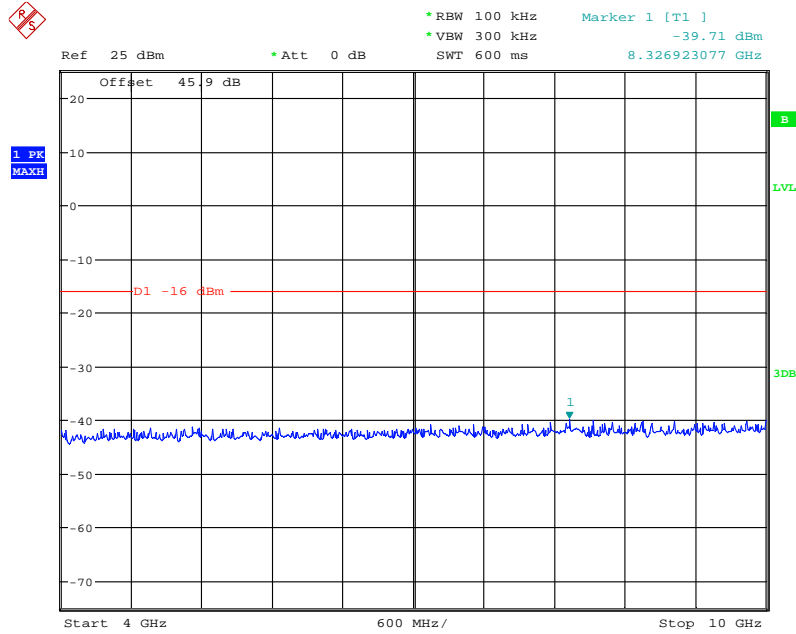

Date: 15.JUL.2013 13:48:44

Configuration 1 - Mode 6 - 10

9kHz to 1.1GHz

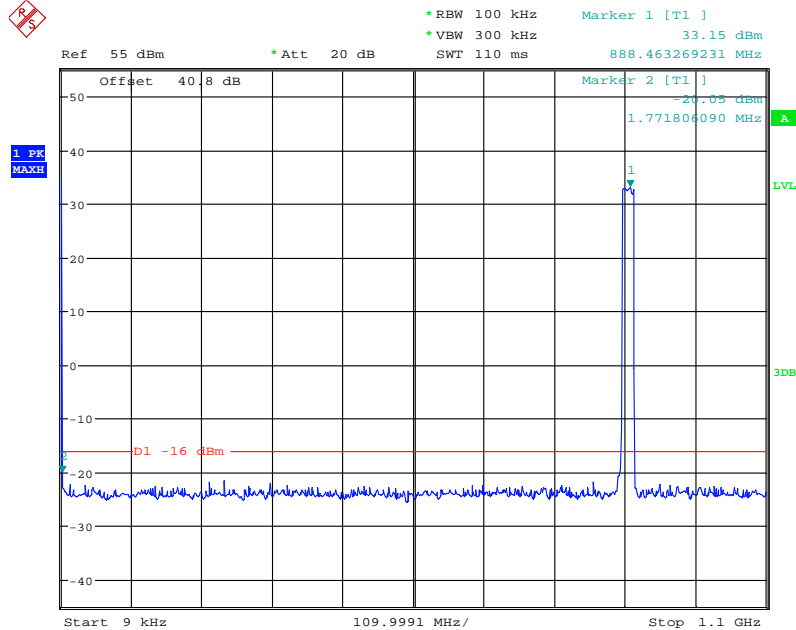

Date: 15.JUL.2013 16:45:23

Note: The emission beyond the limit is the operating frequency.



1.1GHz to 4GHz

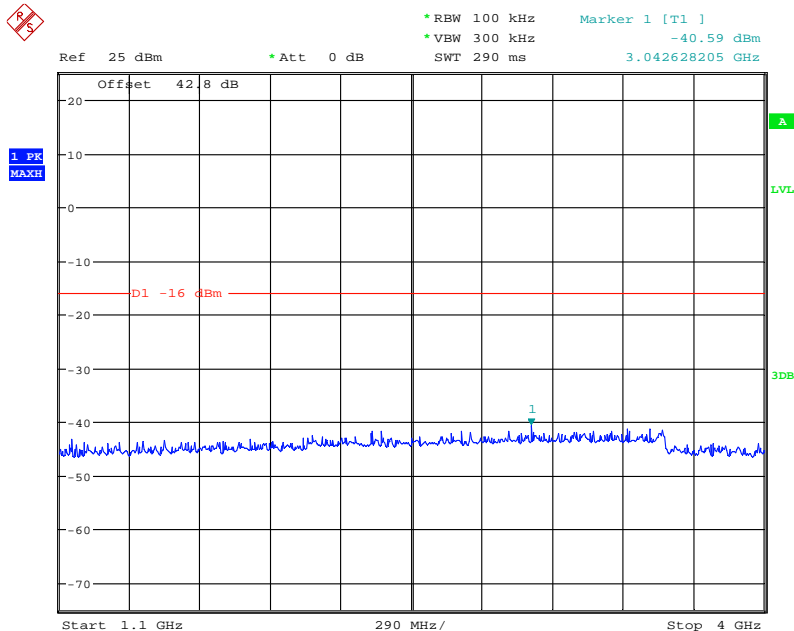

Date: 15.JUL.2013 16:56:08

4GHz to 10GHz

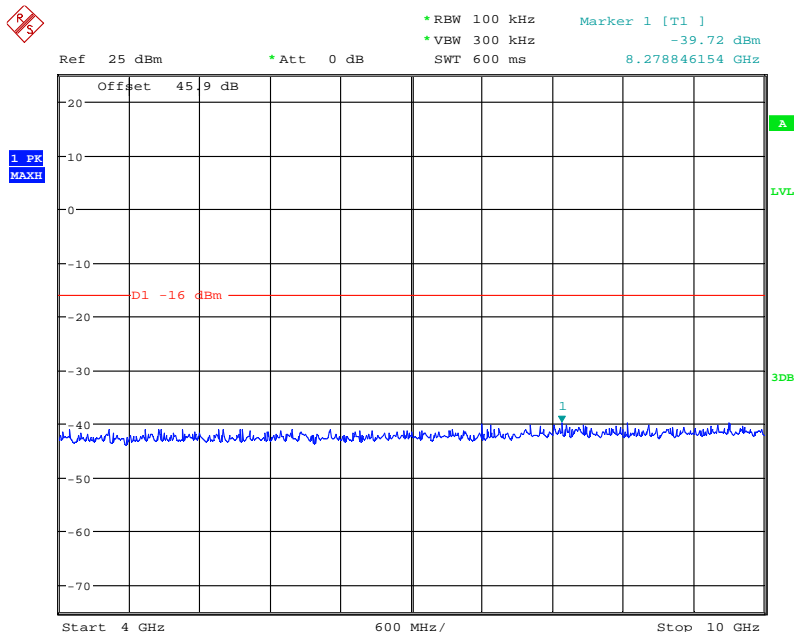

Date: 15.JUL.2013 16:47:08



Product Service

Limit

The power of any emission outside the frequency band shall be attenuated below the transmitter power (P) by at least $43 + 10\log P \text{ dB} + 10\log(NANT)$.

Remarks

The EUT does not exceed -16dBm at the frequency range of 9kHz to 10GHz.



Product Service

2.8 RECEIVER SPURIOUS EMISSIONS

2.8.1 Specification Reference

FCC CFR 47 Part 15, Clause 15.111

2.8.2 Equipment Under Test

RRUS 11 B5 / KRC 161 285/2, S/N: CB4P587217

2.8.3 Date of Test and Modification State

11 and 15 July 2013 – Modification State 0

2.8.4 Test Equipment Used

The major items of test equipment used for the above tests are identified in Section 3.1.

2.8.5 Test Method and Operating Modes

The test was applied in accordance with the test method requirements of FCC CFR 47 Part 15.

In accordance with FCC CFR 47 Part 15 Clause 15.111, the receiver spurious emissions from the antenna terminal were measured. Measurements were performed on the antenna connector RF B. The EUT was set to transmitter mode on the TX connector RF A and during the measurement the RF A was terminated with match load, (50 Ohm).

The resolution was set to 1MHz in the frequency range 9kHz to 10GHz. The spectrum analyzer detector was set to peak and trace was kept on Max Hold to give the worst case. The limit line that apply is -57dBm, 2 nanowatts in band 9kHz to 10GHz .

The maximum path loss across the measurement band was used as the reference level offset to ensure worst case.

Measurements were made from 9kHz up to the 5th harmonic of the highest carrier frequency at least.

The test was performed with the EUT in the following configurations and modes of operation:

Configuration 1 - Mode 2 (1.4MHz OBW)
- Mode 5 - 1.4

2.8.6 Environmental Conditions

	11 July 2013	15 July 2013
Ambient Temperature	22.0°C	23.0°C
Relative Humidity	61.0%	64.5%



2.8.7 Test Results

For the period of test the EUT met the requirements of FCC CFR 47 Part 15 for Receiver Spurious Emissions.

The test results are shown below

Remark:

The emissions at 9kHz on the plots was not generated by the test object. A complementary measruement with a smaller Span showed that it was related to the LO feedthrough.

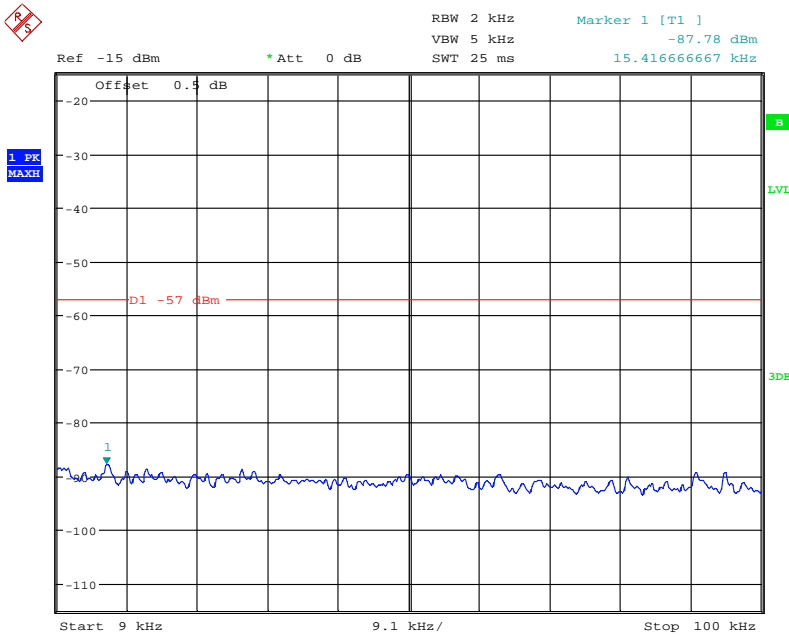

Date: 11.JUL.2013 10:22:01



Single Carrier

E-TM1.1 – 1.4MHz Bandwidth

Configuration 1 - Mode 2

9kHz to 1GHz

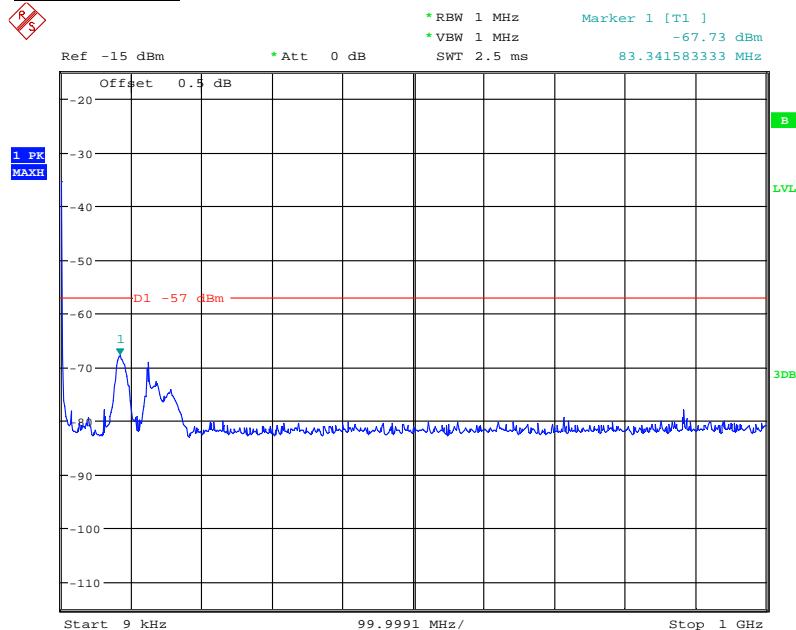

Date: 11.JUL.2013 10:24:48

1GHz to 10GHz

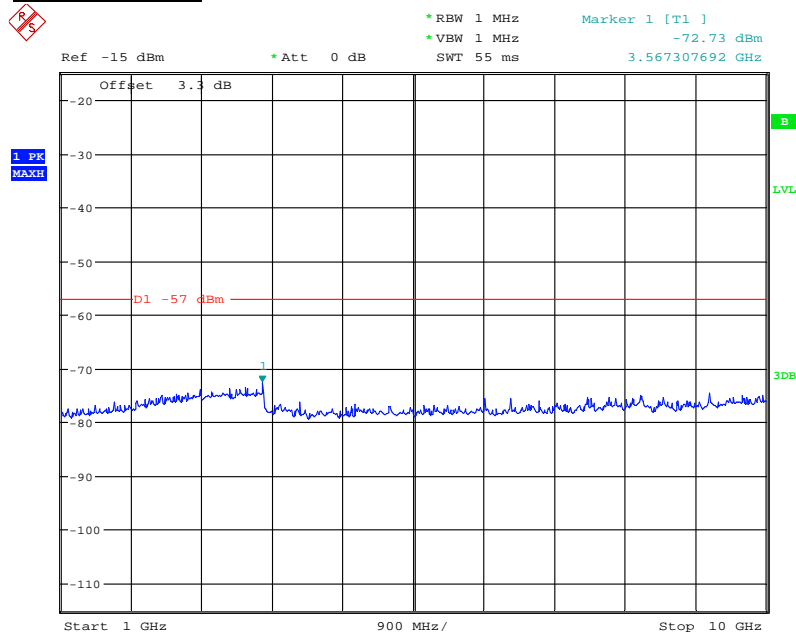

Date: 11.JUL.2013 10:25:44



Multi Carrier (x2)

E-TM1.1 – 1.4MHz Bandwidth

Configuration 1 - Mode 5

9kHz to 1GHz

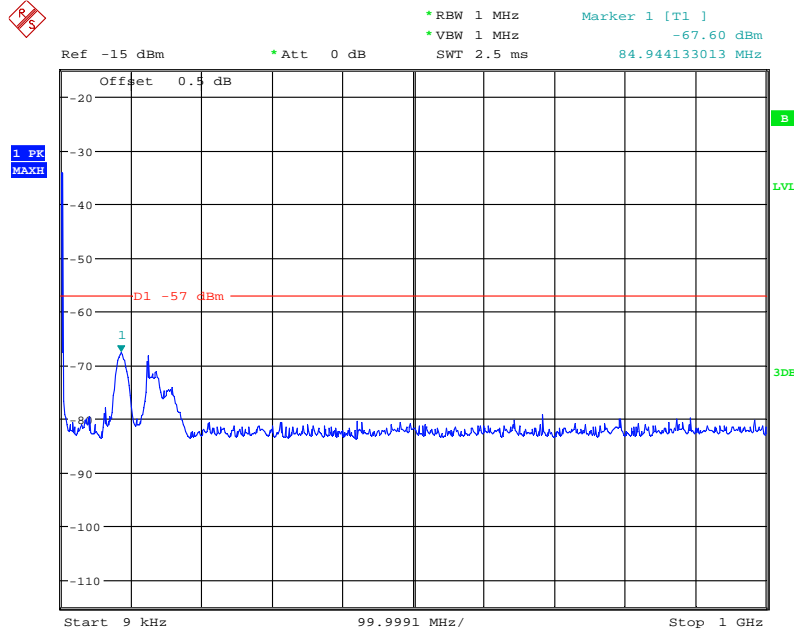

Date: 15.JUL.2013 13:06:45

1GHz to 10GHz

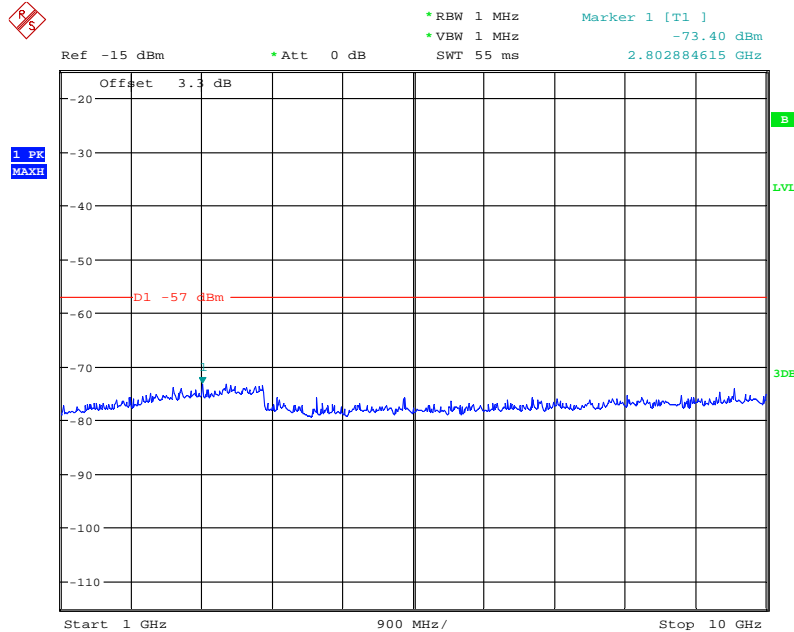

Date: 15.JUL.2013 13:05:16



Product Service

Limit

Receiver spurious emissions shall not exceed -57dBm / 2 nanowatts in the band 9kHz to 10GHz.

Remarks

The EUT does not exceed the limit at the frequency range of 9kHz to 10GHz.



Product Service

SECTION 3

TEST EQUIPMENT USED



3.1 TEST EQUIPMENT USED

List of absolute measuring and other principal items of test equipment.

Instrument	Manufacturer	Type No.	Serial No.	Calibration Period (months)	Calibration Due
Section 2.1, 2.2, 2.3, 2.4, 2.5, 2.7, 2.8 – Maximum Conducted Output Power, Peak – Average Ratio, Modulation Characteristics, Occupied Bandwidth, Spurious Emissions at Antenna Terminals (± 1MHz), Conducted Spurious Emissions and Receiver Spurious Emissions.					
Spectrum Analyser	Rohde & Schwarz	FSQ26	200014	12	06-Sep-2013
Spectrum Analyser	Rohde & Schwarz	FSQ26	201122	12	07-Apr-2014
Power Meter	Rohde & Schwarz	NRP2	101283	12	12-Aug-2013
Power Sensor	Rohde & Schwarz	NRP-Z51	102312	12	12-Aug-2013
Network Analyzer	Agilent	8720D	US36140166	12	06-Sep-2013
40dB Attenuator	Aeroflex / Weinschel	48-40-43-LIM	BR5020	-	O/P MON
Pass Filter	K&L	ULK 904 098/2	16	-	O/P MON
Load	Shanghai Huaxiang	TF100	09121648	-	O/P MON
Power Supply	Dahua	DH1716-5D	2008040041	-	O/P MON
Power Supply	Dahua	DH1716-5D	2008040050	-	O/P MON
Digital Multi-meter	FLUKE	179	91820401	12	13-Dec-2013
Thermo-hygrometer	AZ Instruments	8705	9151655	12	16-Dec-2013
Section 2.6 – Radiated Spurious Emissions					
Load	Shanghai Huaxiang	TF100	09121648	-	O/P MON
Load	Shanghai Huaxiang	TF100	09121605	-	O/P MON
EMI Receiver	Rohde & Schwarz	ESI 40	100015	12	19-Aug-2013
Ultra log test antenna	Rohde & Schwarz	HL562	100167	12	19-Aug-2013
Double-Ridged Wave-guide Horn Antenna	Rohde & Schwarz	HF 906	100029	12	19-Aug-2013
Pyramidal Horn Antenna	EMCO	3160-09	-	-	-
Antenna master	Frankonia	MA 260	-	12	19-Aug-2013
Relay Switch Unit	Rohde & Schwarz	331.1601.31	338965002	-	TU
Semi Anechoic Chamber	Frankonia	23.18m×16.88m×9.60m	-	12	19-Aug-2013
Power Supply	Dahua	DH1716-5D	2008040041	-	O/P MON
Power Supply	Dahua	DH1716-5D	2008040050	-	O/P MON
Digital Multimeter	FLUKE	179	91820401	12	13-Dec-2013
Thermo-hygrometer	AZ Instruments	8705	9151655	12	16-Dec-2013

O/P MON Output monitored with calibration equipment
 TU Traceability Unscheduled



Product Service

3.2 MEASUREMENT UNCERTAINTY

For a 95% confidence level, the measurement uncertainties for defined systems are:-

Test Discipline	Frequency / Parameter	MU
Conducted Maximum Peak Output Power	30MHz to 10GHz Amplitude	0.5dB*
Conducted Emissions	30MHz to 40GHz Amplitude	3.0dB*
Frequency Stability	30MHz to 2GHz Amplitude	$<1 \times 10^{-7}$
Radiated Emissions, Bilog Antenna, AOATS	30MHz to 1GHz Amplitude	5.1dB*
Radiated Emissions, Horn Antenna, AOATS	1GHz to 40GHz Amplitude	6.3dB*
Worst case error for both Time and Frequency measurement 12 parts in 10^6		

* In accordance with CISPR 16-4



Product Service

SECTION 4

ACCREDITATION, DISCLAIMERS AND COPYRIGHT



Product Service

4.1 ACCREDITATION, DISCLAIMERS AND COPYRIGHT



This report relates only to the actual item/items tested.

Our UKAS Accreditation does not cover opinions and interpretations and any expressed are outside the scope of our UKAS Accreditation.

Results of tests not covered by our UKAS Accreditation Schedule are marked NUA
(Not UKAS Accredited).

This report must not be reproduced, except in its entirety, without the written permission of
TÜV SÜD Product Service

© 2013 TÜV SÜD Product Service