



Product Service

**Choose certainty.
Add value.**

Report On

FCC and Industry Canada Testing of the
Ericsson RRUS 11 B5 / KRC 161 285/2

COMMERCIAL-IN-CONFIDENCE

FCC ID: TA8AKRC161285-2
IC ID: 287AB-AS1612852

Document 75915949 Report 01 Issue 1

January 2012



Product Service

TÜV SÜD Product Service Ltd, Octagon House, Concorde Way, Segensworth North,
Fareham, Hampshire, United Kingdom, PO15 5RL
Tel: +44 (0) 1489 558100. Website: www.tuvps.co.uk

COMMERCIAL-IN-CONFIDENCE

REPORT ON

FCC and Industry Canada Testing of the
Ericsson RRUS 11 B5 / KRC 161 285/2

Document 75915949 Report 01 Issue 1

January 2012

PREPARED FOR

Ericsson AB
Torshamnsgatan 23
SE-164 80
Stockholm
Sweden

PREPARED BY



X Zhang
Test Engineer

APPROVED BY

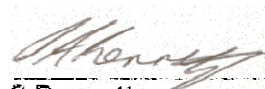

S Bennett
Authorised Signatory

DATED

12 January 2012

ENGINEERING STATEMENT

The measurements shown in this report were made in accordance with the procedures described on test pages. All reported testing was carried out on a sample equipment to demonstrate compliance with FCC CFR 47: Part 22 and Industry Canada RSS-132. The sample tested was found to comply with the requirements defined in the applied rules.

Test Engineer(s);



X Zhang



C Zhang





CONTENTS

Section	Page No
1	REPORT SUMMARY 3
1.1	Introduction 4
1.2	Brief Summary of Results 5
1.3	Declaration of Build Status 7
1.4	Product Information 8
1.5	Test Conditions 13
1.6	Deviations From the Standard 13
1.7	Modification Record 13
1.8	Alternative Test Site 13
2	TEST DETAILS 14
2.1	Maximum Peak Output Power - Conducted 15
2.2	Peak – Average Ratio 18
2.3	Modulation Characteristics 34
2.4	Occupied Bandwidth 37
2.5	Spurious Emissions at Antenna Terminals (± 1 MHz) 46
2.6	Radiated Spurious Emissions 73
2.7	Conducted Spurious Emissions 78
2.8	Frequency Stability Under Temperature Variations 92
2.9	Frequency Stability Under Voltage Variations 94
2.10	Receiver Spurious Emissions 96
3	TEST EQUIPMENT USED 102
3.1	Test Equipment Used 103
3.2	Measurement Uncertainty 105
4	ACCREDITATION, DISCLAIMERS AND COPYRIGHT 106
4.1	Accreditation, Disclaimers and Copyright 107



SECTION 1

REPORT SUMMARY

FCC and Industry Canada Testing of the
Ericsson RRUS 11 B5 / KRC 161 285/2



1.1 INTRODUCTION

The information contained in this report is intended to show verification of the Ericsson RRUS 11 B5 / KRC 161 285/2 to the requirements of FCC CFR 47 Part 22 and Industry Canada RSS-132.

Testing was carried out in support of an application for Grant of Equipment Authorisation in the name of RRUS 11 B5 / KRC 161 285/2.

Objective	To perform FCC and Industry Canada Testing to determine the Equipment Under Test's (EUT's) compliance with the Test Specification, for the series of tests carried out.
Manufacturer	Ericsson AB
Product Name	RRUS 11 B5
Part Number	KRC 161 285/2
IC Model Number	AS1612852
Serial Number(s)	CB4L317562
Software Version	CXP9017316%1_R39UH
Hardware Version	R1C
Number of Samples Tested	1
Test Specification/Issue/Date	FCC CFR 47 Part 22: 2010 Industry Canada RSS-132 issue 2: 2005
Incoming Release Date	Declaration of Build Status 17 November 2011
Order Number Date	9201355994 10 January 2012
Start of Test	17 November 2011
Finish of Test	22 December 2011
Name of Engineer(s)	X Zhang C Zhang
Related Document(s)	ANSI C63.4: 2009 FCC CFR 47 Part 2: 2010 Industry Canada RSS-GEN Issue 3: 2010



1.2 BRIEF SUMMARY OF RESULTS

A brief summary of results in accordance with FCC CFR 47 Part 22 and Industry Canada RSS-132, is shown below.

Configuration 1 – Radio Equipment							
Section	Spec Clause		Test Description	Mode	Mod State	Result	Comments
	FCC Part 2, 22 and 15	RSS-132 and RSS-GEN					
	22.913 (a)	4.4	Effective Radiated Power	869.7MHz (1.4MHz OBW) / 879.0MHz (20.0MHz OBW)		N/A	No integral antenna.
				881.5MHz (1.4MHz, 3.0MHz, 5.0MHz, 10.0MHz, 15.0MHz, 20.0MHz OBW)		N/A	
				893.3MHz (1.4MHz OBW) / 884.0MHz (20.0MHz OBW)		N/A	
2.1	2.1046, 22.913 (a)	4.4	Maximum Peak Output Power - Conducted	869.7MHz (1.4MHz OBW) / 879.0MHz (20.0MHz OBW)	0	Pass	-
				881.5MHz (1.4MHz, 3.0MHz, 5.0MHz, 10.0MHz, 15.0MHz, 20.0MHz OBW)	0	Pass	
				893.3MHz (1.4MHz OBW) / 884.0MHz (20.0MHz OBW)	0	Pass	
2.2	22.913 (a)	-	Peak – Average Ratio	869.7MHz (1.4MHz OBW) / 879.0MHz (20.0MHz OBW)	0	Pass	-
				881.5MHz (1.4MHz, 3.0MHz, 5.0MHz, 10.0MHz, 15.0MHz, 20.0MHz OBW)	0	Pass	
				893.3MHz (1.4MHz OBW) / 884.0MHz (20.0MHz OBW)	0	Pass	
2.3	2.1047 (d)	4.2	Modulation Characteristics	871.5MHz (5.0MHz OBW)		N/A	-
				881.5MHz (5.0MHz OBW)	0	Pass	
				891.5MHz (5.0MHz OBW)		N/A	
2.4	2.1049, 22.917 (b)	RSS-Gen 4.6.1	Occupied Bandwidth	869.7MHz (1.4MHz OBW) / 879.0MHz (20.0MHz OBW)	0	Pass	-
				881.5MHz (1.4MHz, 3.0MHz, 5.0MHz, 10.0MHz, 15.0MHz, 20.0MHz OBW)	0	Pass	
				893.3MHz (1.4MHz OBW) / 884.0MHz (20.0MHz OBW)	0	Pass	



Configuration 1 – Radio Equipment							
Section	Spec Clause		Test Description	Mode	Mod State	Result	Comments
	FCC Part 2, 22 and 15	RSS-132 and RSS-GEN					
2.5	2.1051, 22.917 (b)	4.5	Spurious Emissions at Antenna Terminals (±1MHz)	869.7MHz (1.4MHz OBW) / 870.5MHz (3.0MHz OBW) 871.5MHz (5.0MHz OBW) / 874.0MHz (10.0MHz OBW) 876.5MHz (15.0MHz OBW) / 879.0MHz (20.0MHz OBW)	0	Pass	-
				881.5MHz		N/A	
				893.3MHz (1.4MHz OBW) / 892.5MHz (3.0MHz OBW) 891.5MHz (5.0MHz OBW) / 889.0MHz (10.0MHz OBW) 886.5MHz (15.0MHz OBW) / 884.0MHz (20.0MHz OBW)	0	Pass	
2.6	2.1053, 22.917 (a)	4.5	Radiated Spurious Emissions	869.7MHz (1.4MHz OBW)	0	Pass	-
				881.5MHz (1.4MHz, 3.0MHz, 5.0MHz, 10.0MHz, 15MHz, 20.0MHz OBW)	0	Pass	
				893.3MHz (1.4MHz OBW)	0	Pass	
2.7	2.1051, 22.917 (a)	4.5	Conducted Spurious Emissions	869.7MHz (1.4MHz OBW) / 879.0MHz (20.0MHz OBW)	0	Pass	-
				881.5MHz (1.4MHz, 20.0MHz OBW)	0	Pass	
				893.3MHz (1.4MHz OBW) / 884.0MHz (20.0MHz OBW)	0	Pass	
2.8	2.1055, 22.355	4.3	Frequency Stability Under Temperature Variations	871.5MHz (5.0MHz OBW)		N/A	-
				881.5MHz (5.0MHz OBW)	0	Pass	
				891.5MHz (5.0MHz OBW)		N/A	
2.9	2.1055, 22.355	4.3	Frequency Stability Under Voltage Variations	871.5MHz (5.0MHz OBW)		N/A	-
				881.5MHz (5.0MHz OBW)	0	Pass	
				891.5MHz (5.0MHz OBW)		N/A	
2.10	15.111	4.6	Receiver Spurious Emissions	869.7MHz (1.4MHz OBW)	0	Pass	-
				881.5MHz (1.4MHz OBW)	0	Pass	
				893.3MHz (1.4MHz OBW)	0	Pass	

N/A – Not Applicable



1.3 DECLARATION OF BUILD STATUS

MAIN EUT	
MANUFACTURING DESCRIPTION	Radio Equipment
MANUFACTURER	Ericsson AB
PRODUCT NAME	RRUS 11 B5
PART NUMBER	KRC 161 285/2
IC Model Number	AS1612852
SERIAL NUMBER	CB4L317562
HARDWARE VERSION	R1C
SOFTWARE VERSION	CXP9017316%1_R39UH
TRANSMITTER OPERATING RANGE	TX: 869MHz - 894MHz RX: 824MHz - 849MHz
DUPLEXER MODE	FDD
MODULATIONS	QPSK, 16QAM, 64QAM
INTERMEDIATE FREQUENCIES	--
ITU DESIGNATION OF EMISSION	1M40F9W 3M00F9W 5M00F9W 10M0F9W 15M0F9W 20M0F9W
SUPPORTED CHANNEL BANDWIDTH CONFIGURATION	1.4MHz, 3MHz, 5MHz, 10MHz, 15MHz and 20MHz according to 3GPP TS 36.141
OUTPUT POWER (RMS) (W or dBm)	2 x 46dBm (2 x 40W)
OUTPUT POWER TOLERANCE	± 0.6dB
NUMBER OF ANTENNA PORTS	2 TX/RX ports
SUPPORTED CONFIGURATION	Dual Single Carrier. TX Diversity. Both RF chains are identical
FCC ID	TA8AKRC161285-2
IC ID	287AB-AS1612852
TECHNICAL DESCRIPTION (a brief description of the intended use and operation)	The equipment is the Radio Part of LTE Base Station.

Signature

Date

15 November 2011

D of B S Serial No

75915949/01

No responsibility will be accepted by TÜV SÜD Product Service as to the accuracy of the information declared in this document by the manufacturer.



1.4 PRODUCT INFORMATION

1.4.1 Technical Description

The Equipment Under Test (EUT) RRUS 11 B5 / KRC 161 285/2 is an Ericsson Radio Equipment working in the public mobile service 850MHz band which operates in LTE mode. The RRUS 11 B5 / KRC 161 285/2 operates from a -48V DC supply.

The Equipment Under Test (EUT) is shown in the photograph below. A full technical description can be found in the Manufacturers documentation.

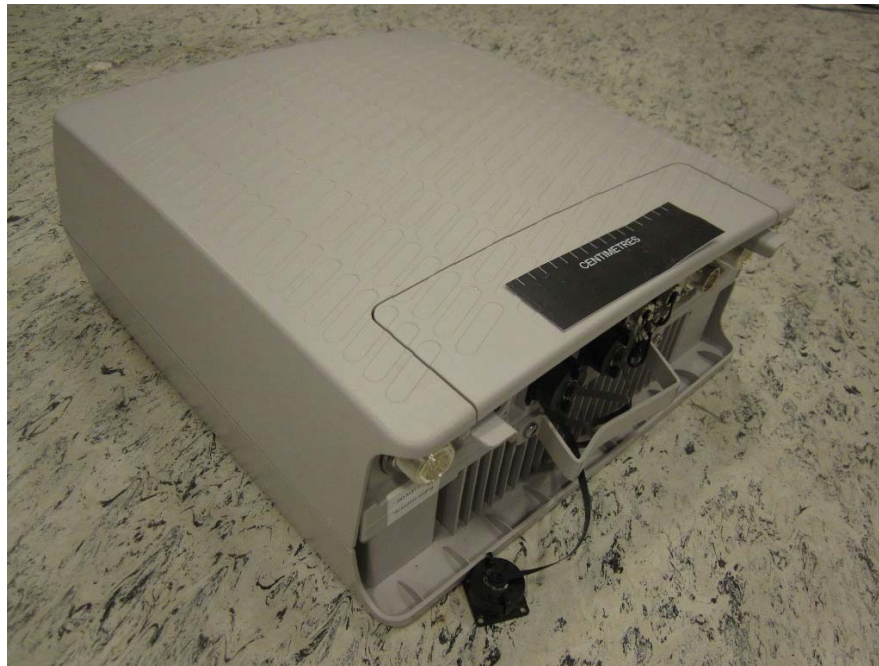

Equipment Under Test



Product Service

1.4.2 Test Configuration

Configuration 1: Radio Equipment

The EUT was configured in accordance with FCC CFR 47 Part 22 and Industry Canada RSS-132.

The RRUS 11 B5 / KRC 161 285/2 supports both dual single mode and Tx Diversity mode. Both modes have been included when several settings were tested to find worst case setting, and Tx Diversity was used for the TX measurements.

The RRUS 11 B5 / KRC 161 285/2 supports Test Models E-TM1.1, E-TM3.2 and E-TM3.1 at 850MHz defined in 3GPP TS 36.141. Test Model E-TM1.1 was used to represent QPSK modulation only, Test Model E-TM3.2 was used to represent 16QAM modulation, and Test Model E-TM3.1 was used to represent 64QAM modulation.

The settings below were found to be representative for all traffic scenarios when several settings with the different modulations, channel bandwidths were tested to find the worst case setting. These settings were used for all measurements if not otherwise noted:

- Test Model E-TM1.1 in channel bandwidth 1.4MHz and 20MHz.

The EUT has two TX/RX ports and it can be configured to transmit in 850MHz with both TX are active.

For TX test cases: Maximum Conducted Output Power, Peak – Average Ratio, Spurious Emissions at Antenna Terminals (± 1 MHz) and Conducted Spurious Emissions, measurements were performed on both combined TX/RX output connectors RF A and RF B of the EUT. For all other TX test cases, measurements were performed on the combined TX/RX output connector RF A. RX testing was performed on the RX connector RF B of the EUT when the ETU was set as single transmitter. The complete testing was performed with the EUT transmitting at maximum RF power unless otherwise stated.

The EUT was powered by a -48V DC Power supply.



Test Setup, Conducted Measurement:

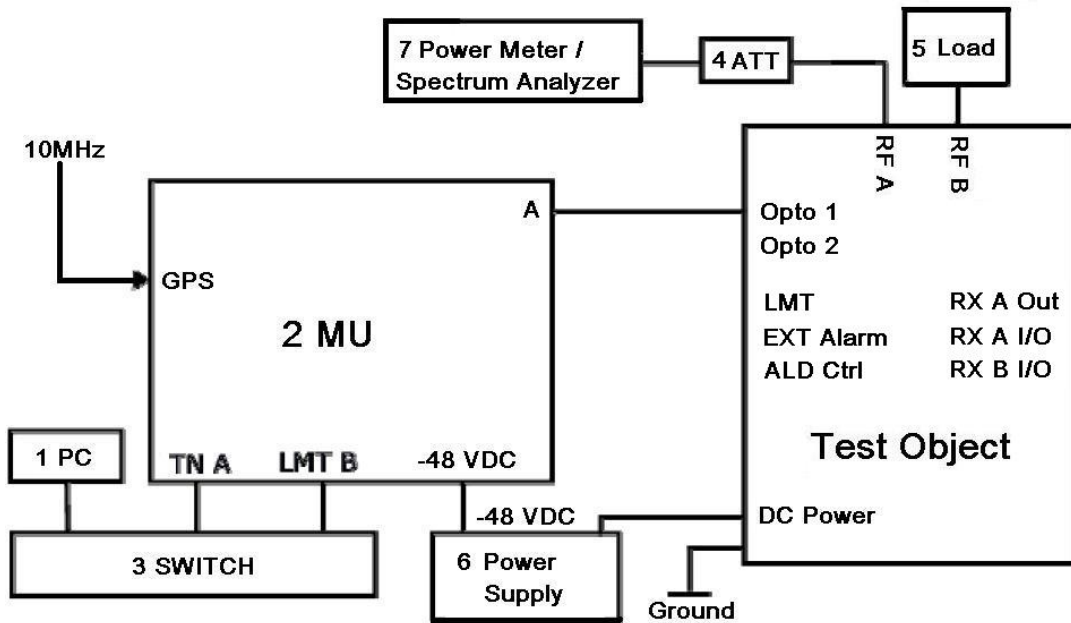

Test Object	Part Number	Version	Serial Number
Radio Part	RRUS 11 B5 / KRC 161 285/2	R1C	CB4L317562

No.	Auxiliary Equipment	Part Number / Model Type	Version	Serial Number
1	Computer	HP Compaq nc4400	--	CND6460KCL
2	RBS 6601	BFL 901 009/1	--	--
	DUL 20 01	KDU 137 533/4	R1C	C824928277
	SUP 6601	1/BFL 901 009/1	R3B	BR81262575
3	Switch	TEH1085K	--	S108SK014848011011
4	Attenuator	48-40-43-LIM	--	BR5020
5	Load	TF100	--	09121614
6	Power Supply	DH1716-5D	--	2007060047
		DH1716A-14	--	20080401
7	Power Meter	Rohde & Schwarz NRP	--	102438
	Thermal Power Sensor	Rohde & Schwarz NRP-Z51	--	102431
	Spectrum Analyzer	FSQ26	--	100253



Test Setup, Radiated Measurement:

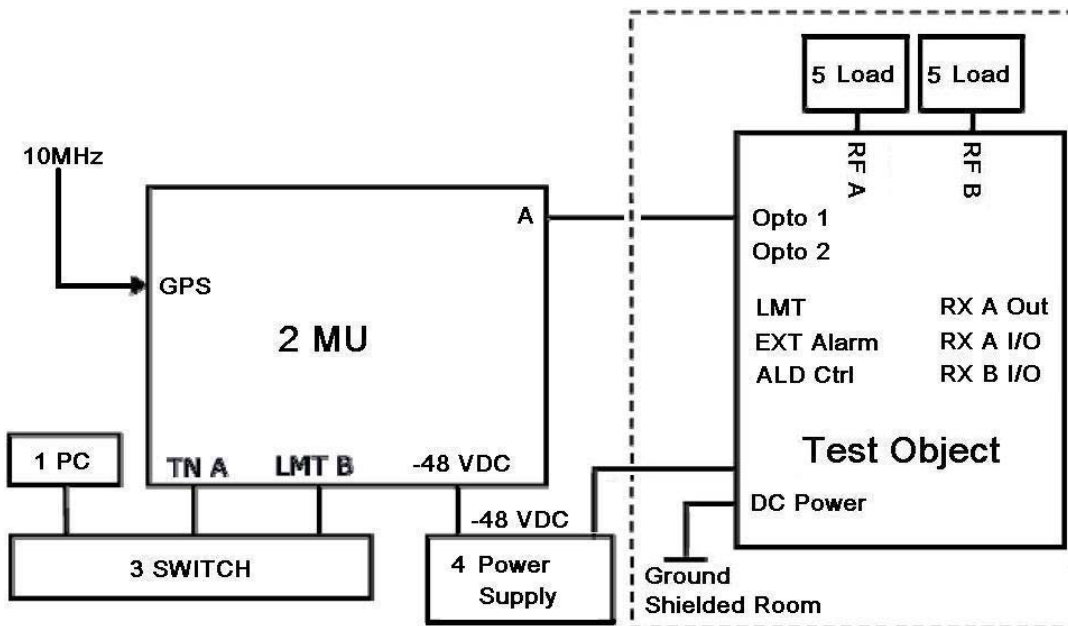

Test Object	Part Number	Version	Serial Number
Radio Part	RRUS 11 B5 / KRC 161 285/2	R1C	CB4L317562

No.	Auxiliary Equipment	Part Number / Model Type	Version	Serial Number
1	Computer	HP Compaq nc4400	--	CND6460KCL
2	RBS 6601	BFL 901 009/1	--	--
	DUL 20 01	KDU 137 533/4	R1C	C824928277
	SUP 6601	1/BFL 901 009/1	R3B	BR81262575
3	Switch	TEH1085K	--	S108SK014848011011
4	Power Supply	DH1716-5D	--	2007060047
		DH1716A-14	--	20080401
5	Load	TF150-3	--	090323436
	Load	TF100	--	09121614



1.4.3 Modes of Operation

Modes of operation of each EUT during testing were as follows:

Bottom Channel :

Mode 1 - 1.4 : EARFCN 2407: 869.7MHz (1.4MHz Bandwidth)

Mode 1 - 3 : EARFCN 2415: 870.5MHz (3.0MHz Bandwidth)

Mode 1 - 5 : EARFCN 2425: 871.5MHz (5.0MHz Bandwidth)

Mode 1 - 10 : EARFCN 2450: 874.0MHz (10.0MHz Bandwidth)

Mode 1 - 15 : EARFCN 2475: 876.5MHz (15.0MHz Bandwidth)

Mode 1 - 20 : EARFCN 2500: 879.0MHz (20.0MHz Bandwidth)

Middle Channel :

Mode 2 : EARFCN 2525: 881.5MHz

Top Channel :

Mode 3 - 1.4 : EARFCN 2643: 893.3MHz (1.4MHz Bandwidth)

Mode 3 - 3 : EARFCN 2635: 892.5MHz (3.0MHz Bandwidth)

Mode 3 - 5 : EARFCN 2625: 891.5MHz (5.0MHz Bandwidth)

Mode 3 - 10 : EARFCN 2600: 889.0MHz (10.0MHz Bandwidth)

Mode 3 - 15 : EARFCN 2575: 886.5MHz (15.0MHz Bandwidth)

Mode 3 - 20 : EARFCN 2550: 884.0MHz (20.0MHz Bandwidth)

Information on the specific test modes utilised are detailed in the test procedure for each individual test.



Product Service

1.5 TEST CONDITIONS

For all tests the EUT was set up in accordance with the relevant test standard and to represent typical operating conditions. Tests were applied with the EUT situated in a shielded enclosure, test laboratories or an open test area as appropriate.

The EUT was powered from a -48V DC supply.

1.6 DEVIATIONS FROM THE STANDARD

No deviations from the applicable test standards or test plan were made during testing.

1.7 MODIFICATION RECORD

No modifications were made to the EUT during testing.

1.8 ALTERNATIVE TEST SITE

Testing has been performed under the following site registrations:

FCC Accreditation 910917:

The State Radio Monitoring Centre, No.80 Beilishi Road Xicheng District Beijing, China.

Industry Canada Accreditation 7308A:

The State Radio Monitoring Centre, No.80 Beilishi Road Xicheng District Beijing, China.



Product Service

SECTION 2

TEST DETAILS

FCC and Industry Canada Testing of the
Ericsson RRUS 11 B5 / KRC 161 285/2



Product Service

2.1 MAXIMUM PEAK OUTPUT POWER - CONDUCTED

2.1.1 Specification Reference

FCC CFR 47 Part 2, Clause 2.1046
 FCC CFR 47 Part 22, Clause 22.913 (a)
 Industry Canada RSS-132, Clause 4.4

2.1.2 Equipment Under Test

RRUS 11 B5 / KRC 161 285/2, S/N: CB4L317562

2.1.3 Date of Test and Modification State

17 November 2011 – Modification State 0

2.1.4 Test Equipment Used

The major items of test equipment used for the above tests are identified in Section 3.1.

2.1.5 Test Method and Operating Modes

The test was applied in accordance with the test method requirements of FCC CFR 47 Part 2 and Part 22 and Industry Canada RSS-132.

Using a power meter and attenuator(s), the output power of the EUT was measured at the antenna terminal. The carrier power was measured with E-TM1.1, E-TM3.2 and E-TM3.1 test models.

Since the EUT transmits on two antennas simultaneously in the same frequency range, i.e. TX Diversity, using the Measure-and-Sum approach, the output power at both antennas were tested, and the total output power were then summed mathematically in linear power units.

The path loss was measured and entered as a reference level offset.

The test was performed with the EUT in the following configurations and modes of operation:

Configuration 1 - Mode 1 - 1.4, Mode 1 - 20
 - Mode 2 (1.4MHz, 3.0MHz, 5.0MHz, 10.0MHz, 15.0MHz, 20MHz OBW)
 - Mode 3 - 1.4, Mode 3 - 20

2.1.6 Environmental Conditions

17 November 2011

Ambient Temperature 28.2°C

Relative Humidity 45.8%



2.1.7 Test Results

For the period of test the EUT met the requirements of FCC CFR 47 Part 2 and Part 22 and Industry Canada RSS-132 for Maximum Peak Output Power.

The test results are shown below

Antenna A and B

E-TM1.1: 1.4MHz Bandwidth

Configuration 1 - Mode 1 - 1.4, Mode 2 and Mode 3 - 1.4

EARFCN	Frequency (MHz)	Antenna A		Antenna B		Total (dBm) RMS	Total (W) RMS
		Result (dBm) RMS	Result (W) RMS	Result (dBm) RMS	Result (W) RMS		
2407	869.7	45.65	36.73	45.72	37.33	48.70	74.05
2525	881.5	45.96	39.45	45.91	38.99	48.92	78.43
2643	893.3	45.55	35.89	45.47	35.24	48.53	71.13

E-TM1.1: 20.0MHz Bandwidth

Configuration 1 - Mode 1 - 20, Mode 2 and Mode 3 - 20

EARFCN	Frequency (MHz)	Antenna A		Antenna B		Total (dBm) RMS	Total (W) RMS
		Result (dBm) RMS	Result (W) RMS	Result (dBm) RMS	Result (W) RMS		
2500	879.0	45.80	38.02	45.79	37.93	48.81	75.95
2525	881.5	45.69	37.07	45.77	37.76	48.74	74.83
2550	884.0	45.81	38.11	45.79	37.93	48.81	76.04

E-TM1.1: 3.0MHz, 5.0MHz, 10.0MHz and 15.0MHz Bandwidth

Configuration 1 - Mode 2

EARFCN / Frequency (MHz)	BW Configuration (MHz)	Antenna A		Antenna B		Total (dBm) RMS	Total (W) RMS
		Result (dBm) RMS	Result (W) RMS	Result (dBm) RMS	Result (W) RMS		
2525 / 881.5	3.0	45.94	39.26	45.92	39.26	48.95	78.53
	5.0	45.88	38.73	45.84	38.73	48.89	77.45
	10.0	45.85	38.46	45.86	38.46	48.86	76.92
	15.0	45.83	38.28	45.80	38.28	48.84	76.56

**E-TM3.2 and E-TM3.1: 1.4MHz Bandwidth**Configuration 1 - Mode 2

EARFCN / Frequency (MHz)	Test Model	Antenna A		Antenna B		Total (dBm) RMS	Total (W) RMS
		Result (dBm) RMS	Result (W) RMS	Result (dBm) RMS	Result (W) RMS		
2525 / 881.5	E-TM3.2	45.95	39.36	45.89	38.82	48.93	78.17
	E-TM3.1	45.94	39.26	45.88	38.73	48.92	77.99

E-TM3.2 and E-TM3.1: 20.0MHz BandwidthConfiguration 1 - Mode 2

EARFCN / Frequency (MHz)	Test Model	Antenna A		Antenna B		Total (dBm) RMS	Total (W) RMS
		Result (dBm) RMS	Result (W) RMS	Result (dBm) RMS	Result (W) RMS		
2525 / 881.5	E-TM3.2	45.68	36.98	45.72	37.33	48.71	74.31
	E-TM3.1	45.77	37.76	45.76	37.67	48.78	75.43

Limit	≤500W or ≤+57dBm
-------	------------------

Remarks

The EUT does not exceed 500W or 57dBm at the measured frequencies.



Product Service

2.2 PEAK – AVERAGE RATIO

2.2.1 Specification Reference

FCC CFR 47 Part 22, Clause 22.913 (a)

2.2.2 Equipment Under Test

RRUS 11 B5 / KRC 161 285/2, S/N: CB4L317562

2.2.3 Date of Test and Modification State

18 and 29 December 2011 – Modification State 0

2.2.4 Test Equipment Used

The major items of test equipment used for the above tests are identified in Section 3.1.

2.2.5 Test Method and Operating Modes

The test was applied in accordance with the test method requirements of FCC CFR 47 Part 22.

A peak to average ratio measurement is performed at the conducted port of the EUT. The spectrum analyzers Complementary Cumulative Distribution Function (CCDF) measurement profile is used to determine the largest deviation between the average and the peak power of the EUT in given bandwidth. The CCDF curve shows how much time the peak waveform spends at or above a given average power level. The percent of time the signal spends at or above the level defines the probability for that particular power level.

The path loss measured and entered as a reference level offset.

The test was performed with the EUT in the following configurations and modes of operation:

Configuration 1 - Mode 1 - 1.4, Mode 1 - 20
 - Mode 2 (1.4MHz, 3.0MHz, 5.0MHz, 10.0MHz, 15.0MHz, 20MHz OBW)
 - Mode 3 - 1.4, Mode 3 - 20

2.2.6 Environmental Conditions

	18 December 2011	29 December 2011
Ambient Temperature	29.8°C	22.7°C
Relative Humidity	41.0%	22.0%



Product Service

2.2.7 Test Results

For the period of test the EUT met the requirements of FCC CFR 47 Part 22 for Peak – Average Ratio.

The test results are shown below.

Antenna A

E-TM1.1

Configuration 1 - Mode 1 - 1.4

1.4MHz Bandwidth

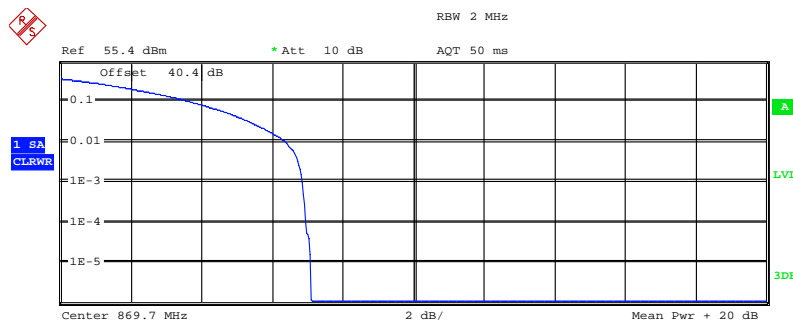

Center 869.7 MHz 2 dB/ Mean Pwr + 20 dB
 Complementary Cumulative Distribution Function
 NOF samples: 100000, Usable BW: 1.7MHz

	Trace 1
Mean	45.14 dBm
Peak	52.24 dBm
Crest	7.09 dB
10 %	3.69 dB
1 %	6.38 dB
.1 %	6.86 dB
.01 %	6.96 dB

Date: 18.NOV.2011 13:09:02



Configuration 1 - Mode 1 - 20

20.0MHz Bandwidth

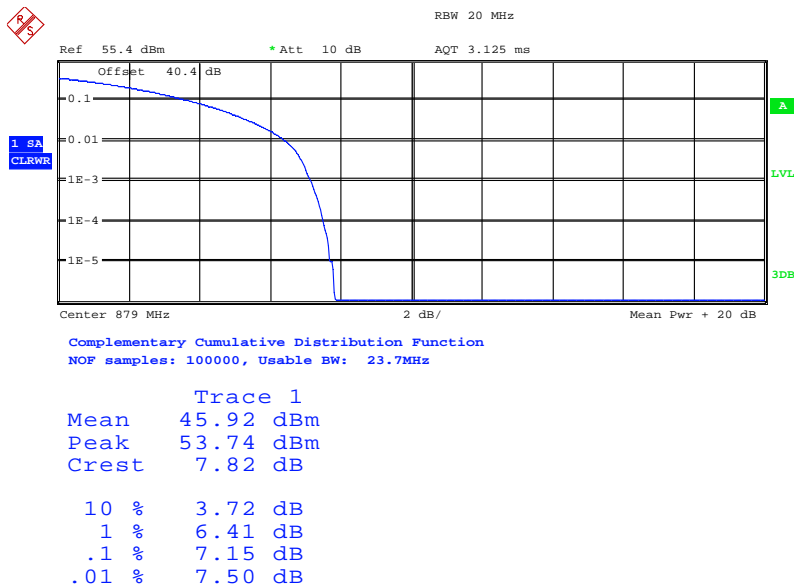

Date: 18.NOV.2011 13:30:45

Configuration 1 - Mode 2

1.4MHz Bandwidth

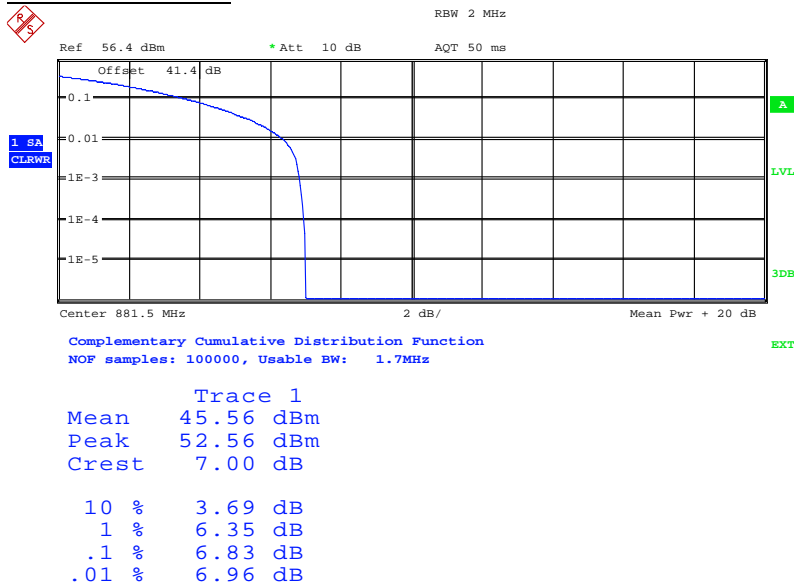

Date: 29.NOV.2011 04:42:35



Product Service

3.0MHz Bandwidth

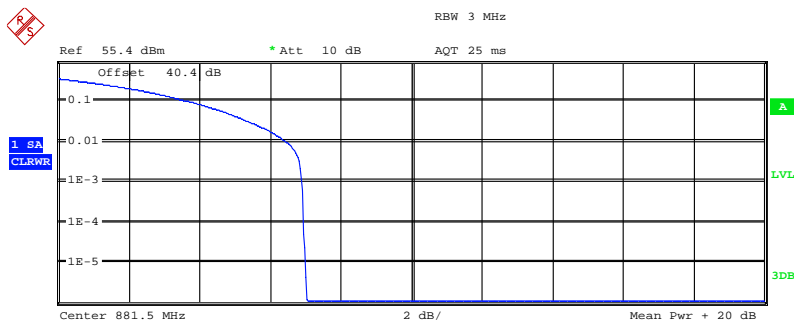

Complementary Cumulative Distribution Function
 NOF samples: 100000, Usable BW: 3.5MHz

Trace 1

Mean	45.64 dBm
Peak	52.66 dBm
Crest	7.02 dB
10 %	3.72 dB
1 %	6.44 dB
.1 %	6.89 dB
.01 %	6.96 dB

Date: 18.NOV.2011 12:43:20

5.0MHz Bandwidth

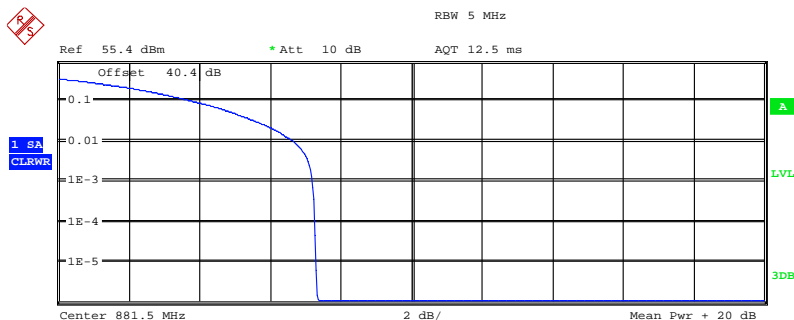

Complementary Cumulative Distribution Function
 NOF samples: 100000, Usable BW: 7.1MHz

Trace 1

Mean	45.32 dBm
Peak	52.66 dBm
Crest	7.34 dB
10 %	3.85 dB
1 %	6.63 dB
.1 %	7.18 dB
.01 %	7.28 dB

Date: 18.NOV.2011 12:36:15



Product Service

10.0MHz Bandwidth

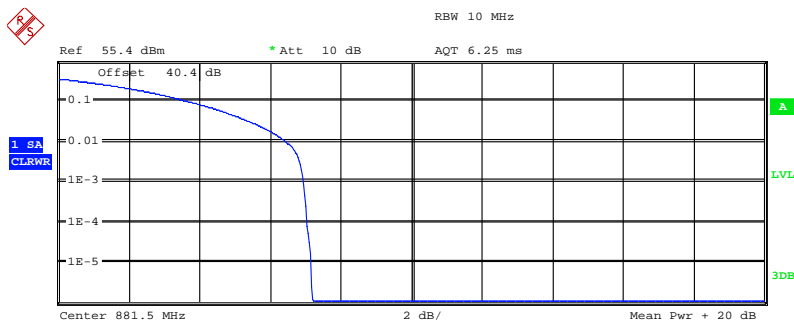

Complementary Cumulative Distribution Function
NOF samples: 100000, Usable BW: 11.2MHz

Trace 1	
Mean	45.88 dBm
Peak	53.05 dBm
Crest	7.17 dB
10 %	3.72 dB
1 %	6.44 dB
.1 %	6.96 dB
.01 %	7.05 dB

Date: 18.NOV.2011 12:48:24

15.0MHz Bandwidth

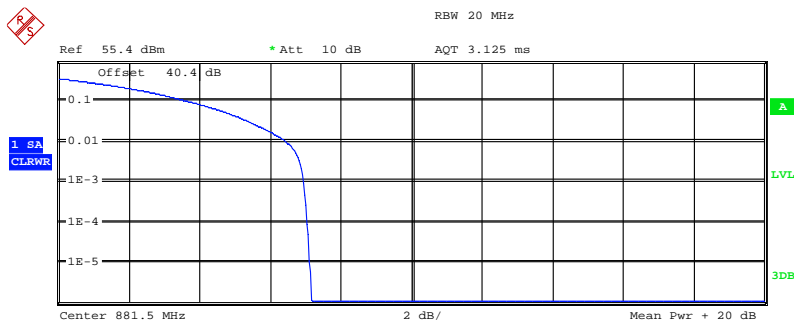

Complementary Cumulative Distribution Function
NOF samples: 100000, Usable BW: 23.7MHz

Trace 1	
Mean	45.88 dBm
Peak	53.06 dBm
Crest	7.17 dB
10 %	3.72 dB
1 %	6.44 dB
.1 %	6.96 dB
.01 %	7.05 dB

Date: 18.NOV.2011 12:51:39



Product Service

20.0MHz Bandwidth

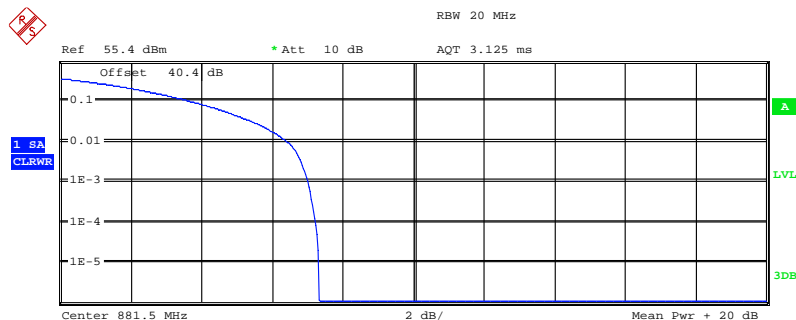

Center 881.5 MHz 2 dB/ Mean Pwr + 20 dB
Complementary Cumulative Distribution Function
NOF samples: 100000, Usable BW: 23.7MHz

Trace 1	
Mean	45.88 dBm
Peak	53.20 dBm
Crest	7.32 dB
10 %	3.72 dB
1 %	6.41 dB
.1 %	7.02 dB
.01 %	7.21 dB

Date: 18.NOV.2011 12:54:53

Configuration 1 - Mode 3 - 1.4

1.4MHz Bandwidth

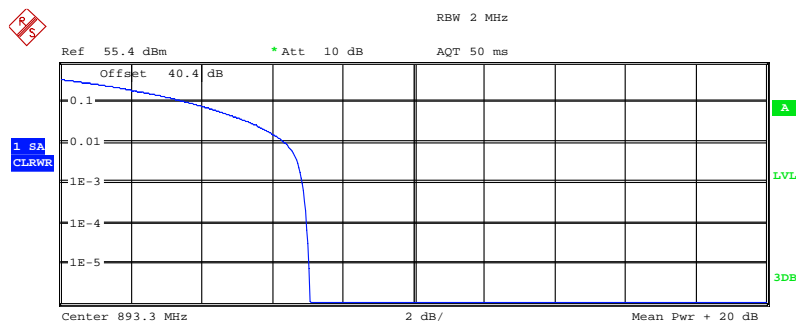

Center 893.3 MHz 2 dB/ Mean Pwr + 20 dB
Complementary Cumulative Distribution Function
NOF samples: 100000, Usable BW: 1.7MHz

Trace 1	
Mean	45.04 dBm
Peak	52.10 dBm
Crest	7.05 dB
10 %	3.65 dB
1 %	6.35 dB
.1 %	6.86 dB
.01 %	6.99 dB

Date: 18.NOV.2011 13:14:16



Configuration 1 - Mode 3 - 20

20.0MHz Bandwidth

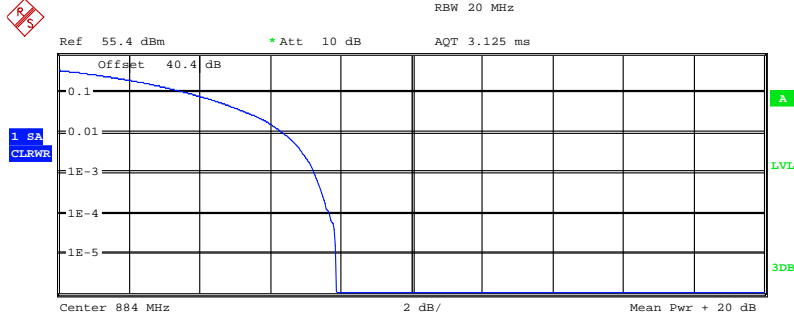

Center 884 MHz 2 dB/ Mean Pwr + 20 dB
 Complementary Cumulative Distribution Function
 NOF samples: 100000, Usable BW: 23.7MHz

Trace 1	
Mean	45.92 dBm
Peak	53.79 dBm
Crest	7.86 dB
10 %	3.72 dB
1 %	6.38 dB
.1 %	7.24 dB
.01 %	7.69 dB

Date: 18.NOV.2011 13:17:41

E-TM3.2

Configuration 1 - Mode 2

1.4MHz Bandwidth

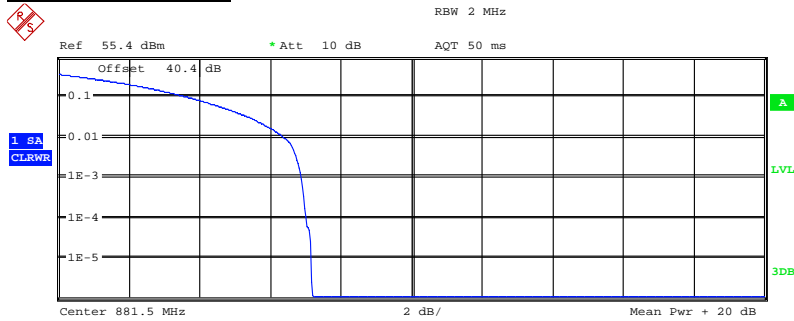

Center 881.5 MHz 2 dB/ Mean Pwr + 20 dB
 Complementary Cumulative Distribution Function
 NOF samples: 100000, Usable BW: 1.7MHz

Trace 1	
Mean	45.42 dBm
Peak	52.59 dBm
Crest	7.17 dB
10 %	3.72 dB
1 %	6.38 dB
.1 %	6.89 dB
.01 %	7.02 dB

Date: 18.NOV.2011 13:03:07



20.0MHz Bandwidth

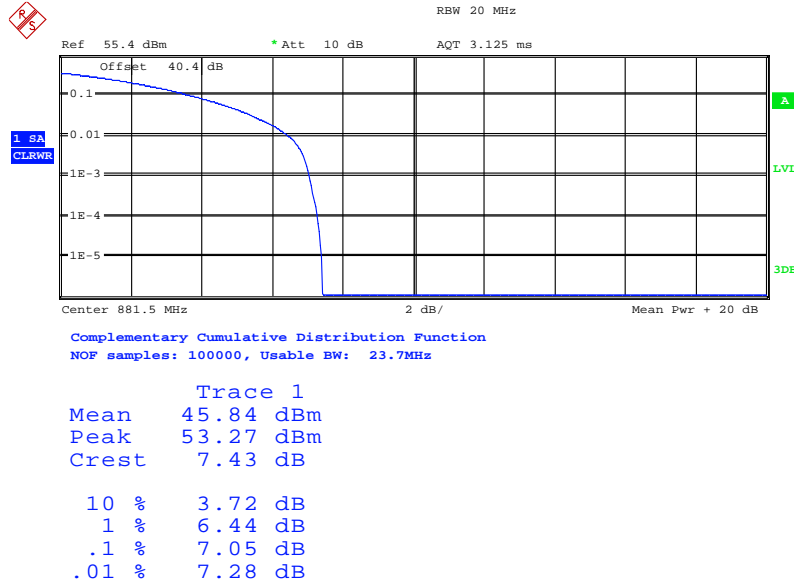

E-TM3.1

Configuration 1 - Mode 2

1.4MHz Bandwidth

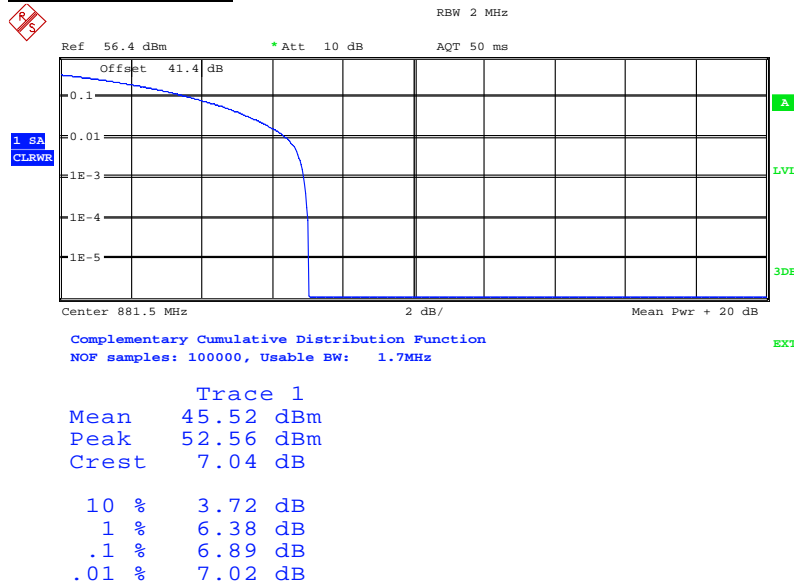



20.0MHz Bandwidth

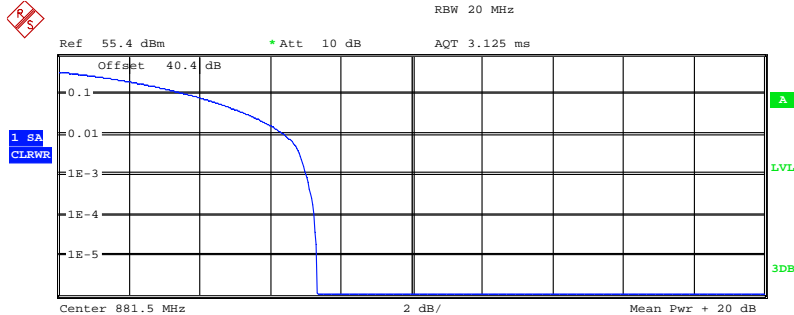

Complementary Cumulative Distribution Function
 NOF samples: 100000, Usable BW: 23.7MHz

Trace 1	
Mean	45.87 dBm
Peak	53.20 dBm
Crest	7.33 dB
10 %	3.72 dB
1 %	6.41 dB
.1 %	7.02 dB
.01 %	7.24 dB

Date: 18.NOV.2011 13:00:22

Antenna B

E-TM1.1

Configuration 1 - Mode 1 - 1.4

1.4MHz Bandwidth

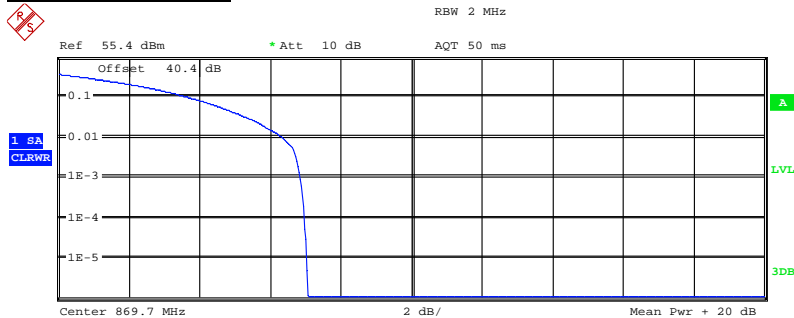

Complementary Cumulative Distribution Function
 NOF samples: 100000, Usable BW: 1.7MHz

Trace 1	
Mean	45.19 dBm
Peak	52.24 dBm
Crest	7.05 dB
10 %	3.69 dB
1 %	6.31 dB
.1 %	6.86 dB
.01 %	6.99 dB

Date: 18.NOV.2011 14:51:55



Configuration 1 - Mode 1 - 20

20.0MHz Bandwidth

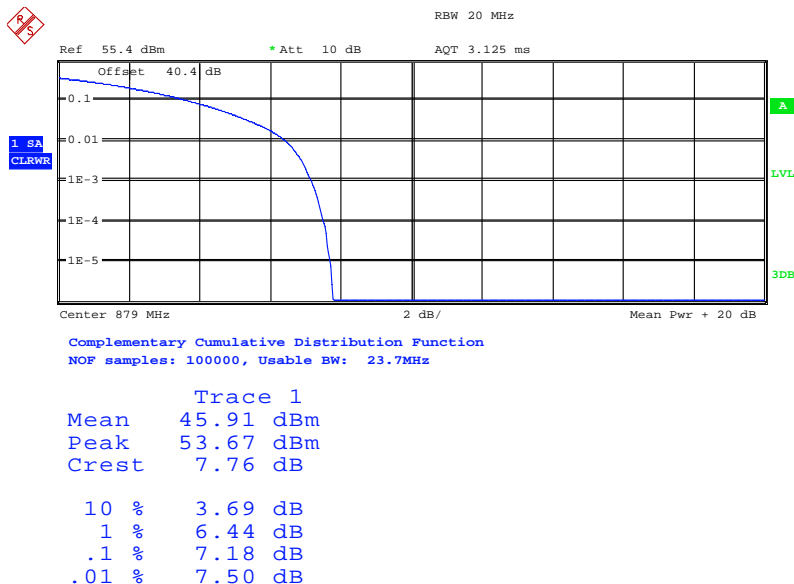

Date: 18.NOV.2011 13:36:20

Configuration 1 - Mode 2

1.4MHz Bandwidth

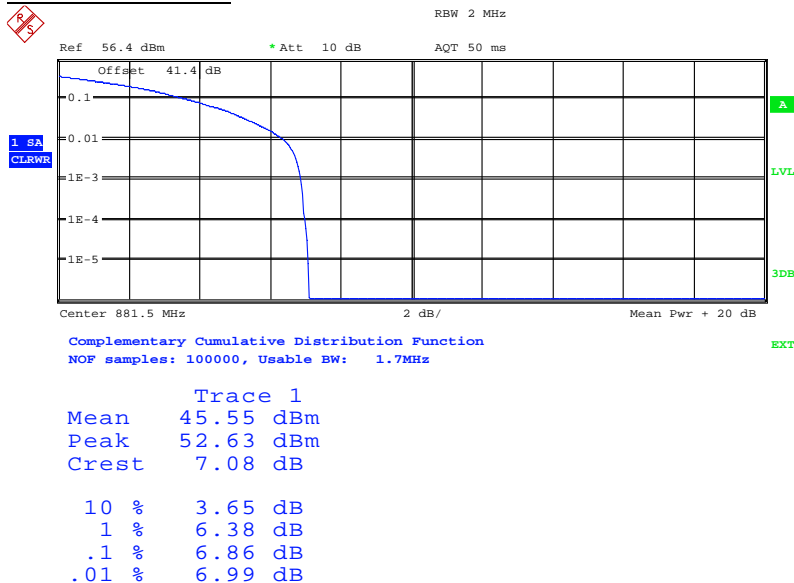

Date: 29.NOV.2011 04:44:54



3.0MHz Bandwidth

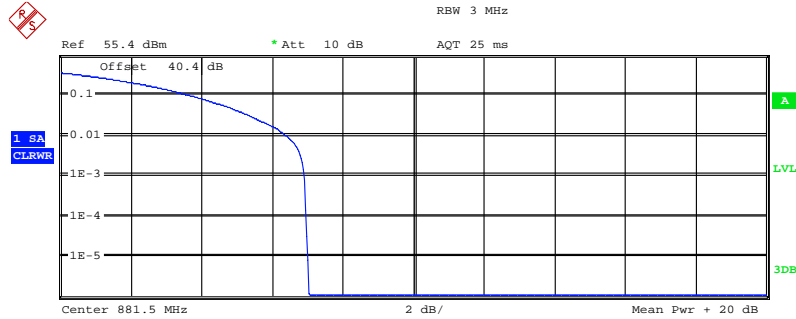

Complementary Cumulative Distribution Function
 NOF samples: 100000, Usable BW: 3.5MHz

Trace 1

Mean	45.57 dBm
Peak	52.59 dBm
Crest	7.02 dB
10 %	3.69 dB
1 %	6.38 dB
.1 %	6.92 dB
.01 %	6.96 dB

Date: 18.NOV.2011 14:18:33

5.0MHz Bandwidth

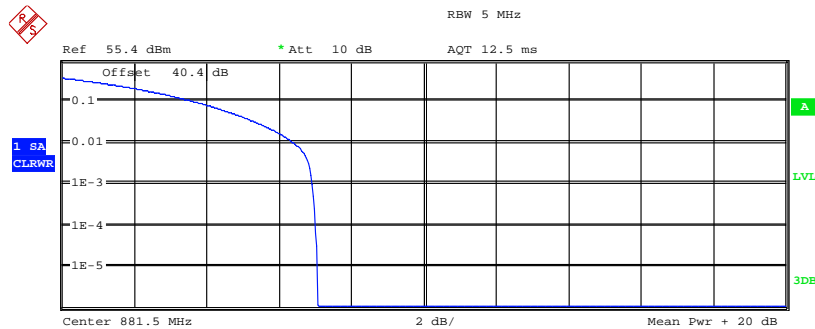

Complementary Cumulative Distribution Function
 NOF samples: 100000, Usable BW: 7.1MHz

Trace 1

Mean	45.59 dBm
Peak	52.66 dBm
Crest	7.07 dB
10 %	3.69 dB
1 %	6.38 dB
.1 %	6.92 dB
.01 %	7.02 dB

Date: 18.NOV.2011 14:24:07



10.0MHz Bandwidth

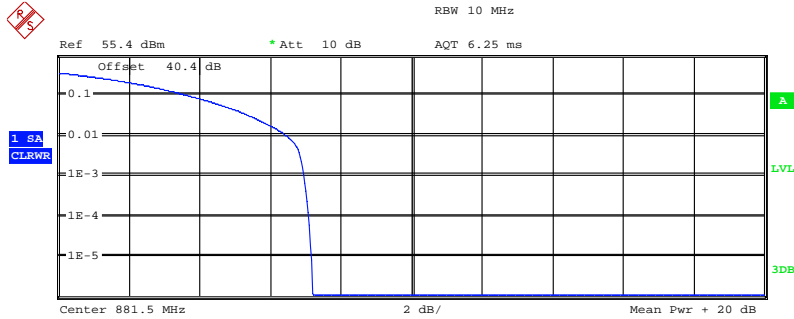

Center 881.5 MHz 2 dB/ Mean Pwr + 20 dB
Complementary Cumulative Distribution Function
NOF samples: 100000, Usable BW: 11.2MHz

Trace 1	
Mean	45.86 dBm
Peak	53.05 dBm
Crest	7.19 dB
10 %	3.69 dB
1 %	6.44 dB
.1 %	6.96 dB
.01 %	7.08 dB

Date: 18.NOV.2011 14:27:18

15.0MHz Bandwidth

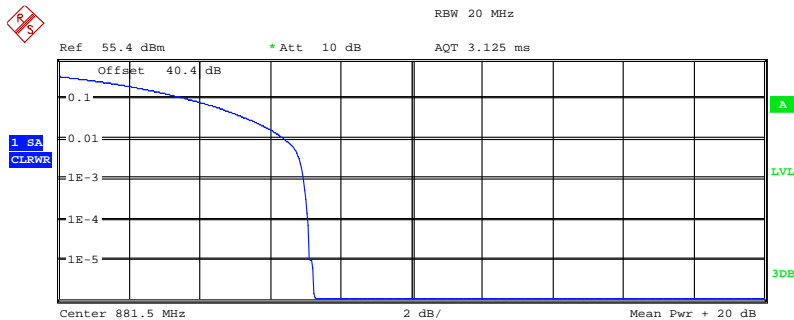

Center 881.5 MHz 2 dB/ Mean Pwr + 20 dB
Complementary Cumulative Distribution Function
NOF samples: 100000, Usable BW: 23.7MHz

Trace 1	
Mean	45.89 dBm
Peak	53.13 dBm
Crest	7.24 dB
10 %	3.72 dB
1 %	6.41 dB
.1 %	6.96 dB
.01 %	7.08 dB

Date: 18.NOV.2011 14:33:16



Product Service

20.0MHz Bandwidth

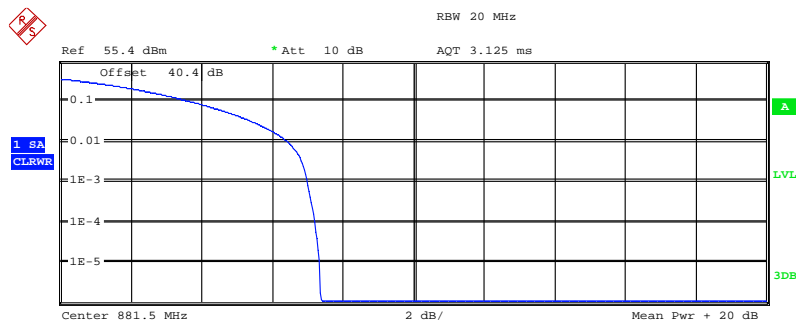

Center 881.5 MHz 2 dB/ Mean Pwr + 20 dB
 Complementary Cumulative Distribution Function
 NOF samples: 100000, Usable BW: 23.7MHz

Trace 1	
Mean	45.83 dBm
Peak	53.20 dBm
Crest	7.37 dB
10 %	3.72 dB
1 %	6.41 dB
.1 %	6.99 dB
.01 %	7.21 dB

Date: 18.NOV.2011 14:15:17

Configuration 1 - Mode 3 - 1.4

1.4MHz Bandwidth

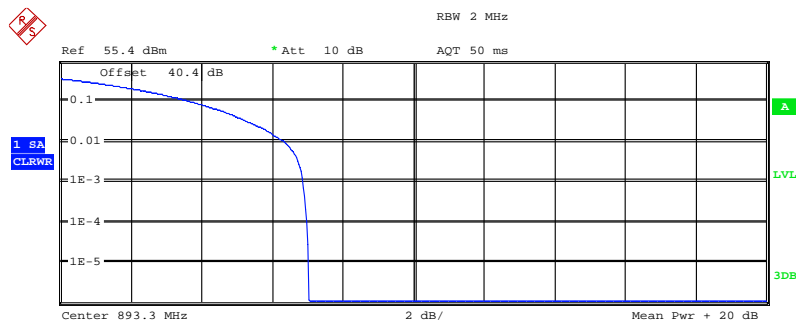

Center 893.3 MHz 2 dB/ Mean Pwr + 20 dB
 Complementary Cumulative Distribution Function
 NOF samples: 100000, Usable BW: 1.7MHz

Trace 1	
Mean	44.93 dBm
Peak	51.95 dBm
Crest	7.02 dB
10 %	3.69 dB
1 %	6.35 dB
.1 %	6.86 dB
.01 %	6.99 dB

Date: 18.NOV.2011 14:56:13



Configuration 1 - Mode 3 - 20

20.0MHz Bandwidth

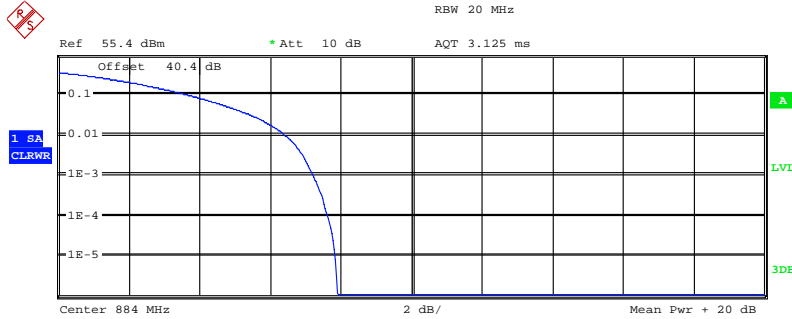

Complementary Cumulative Distribution Function
NOF samples: 100000, Usable BW: 23.7MHz

Trace 1	
Mean	45.89 dBm
Peak	53.79 dBm
Crest	7.89 dB
10 %	3.72 dB
1 %	6.41 dB
.1 %	7.21 dB
.01 %	7.63 dB

Date: 18.NOV.2011 13:43:10

E-TM3.2

Configuration 1 - Mode 2

1.4MHz Bandwidth

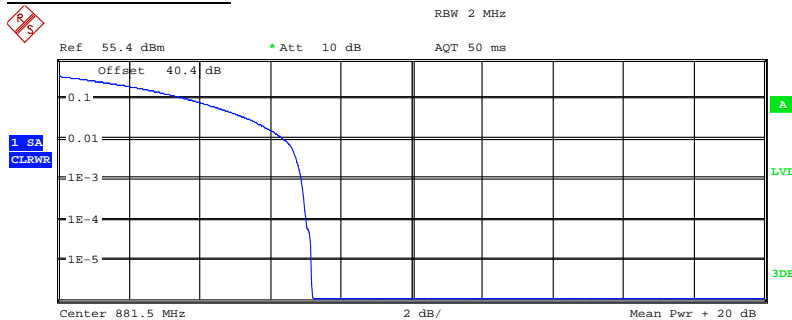

Complementary Cumulative Distribution Function
NOF samples: 100000, Usable BW: 1.7MHz

Trace 1	
Mean	45.42 dBm
Peak	52.59 dBm
Crest	7.17 dB
10 %	3.72 dB
1 %	6.38 dB
.1 %	6.89 dB
.01 %	7.02 dB

Date: 18.NOV.2011 13:03:07



20.0MHz Bandwidth

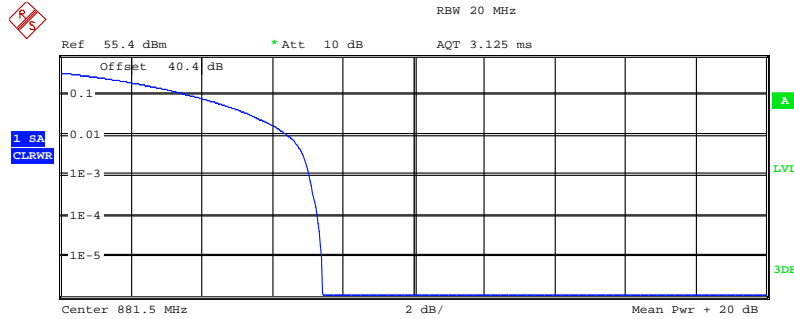

Complementary Cumulative Distribution Function
 NOF samples: 100000, Usable BW: 23.7MHz

Trace 1	
Mean	45.84 dBm
Peak	53.27 dBm
Crest	7.43 dB
10 %	3.72 dB
1 %	6.44 dB
.1 %	7.05 dB
.01 %	7.28 dB

Date: 18.NOV.2011 12:57:59

E-TM3.1

Configuration 1 - Mode 2

1.4MHz Bandwidth

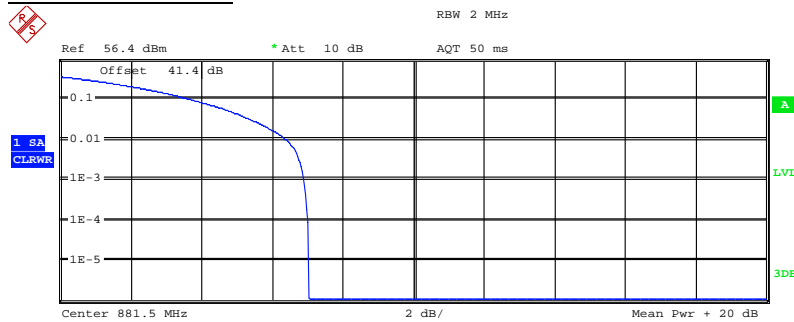

Complementary Cumulative Distribution Function
 NOF samples: 100000, Usable BW: 1.7MHz

Trace 1	
Mean	45.52 dBm
Peak	52.56 dBm
Crest	7.04 dB
10 %	3.72 dB
1 %	6.38 dB
.1 %	6.89 dB
.01 %	7.02 dB

Date: 29.NOV.2011 04:48:43



Product Service

20.0MHz Bandwidth

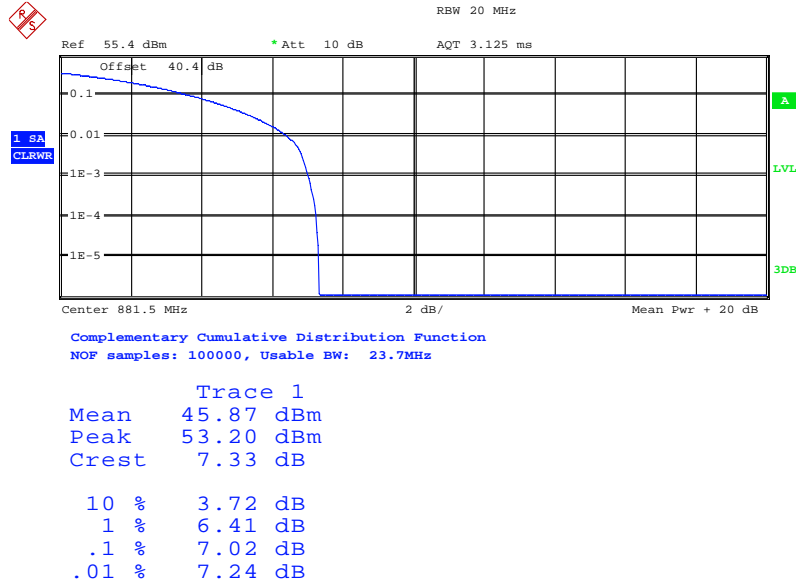

Date: 18.NOV.2011 13:00:22

Limit	13dB
-------	------

Remarks

The Peak – Average ratio does not exceed 13dB at the measured frequencies.



Product Service

2.3 MODULATION CHARACTERISTICS

2.3.1 Specification Reference

FCC CFR 47 Part 2, Clause 2.1047 (d)
Industry Canada RSS-132 Clause 4.2

2.3.2 Equipment Under Test

RRUS 11 B5 / KRC 161 285/2, S/N: CB4L317562

2.3.3 Date of Test and Modification State

18 November 2011 – Modification State 0

2.3.4 Test Method and Operating Modes

The test was applied in accordance with the test method requirements of FCC CFR 47 Part 2 and Industry Canada RSS-132.

Connect the TX output connector RF A to a spectrum analyzer with an attenuator. The other connector RF B was connected to match load. The EUT was controlled to transmit maximum power. Measure and record the constellation of the EUT by the spectrum analyzer.

The EUT supports QPSK, 16QAM and 64QAM modulations and was tested in 5MHz Bandwidth.

The test was performed with the EUT in the following configurations and modes of operation:

Configuration 1 - Mode 2 (5.0MHz OBW)

2.3.5 Environmental Conditions

	18 November 2011
Ambient Temperature	29.8°C
Relative Humidity	41.0%



2.3.6 Test Results

Plots are listed on the following showing the EUT transmitting with all of the modulations:

The test results are shown below

Configuration 1 - Mode 2

5.0MHz Bandwidth

E-TM1.1: EUT transmitting with QPSK modulation in:

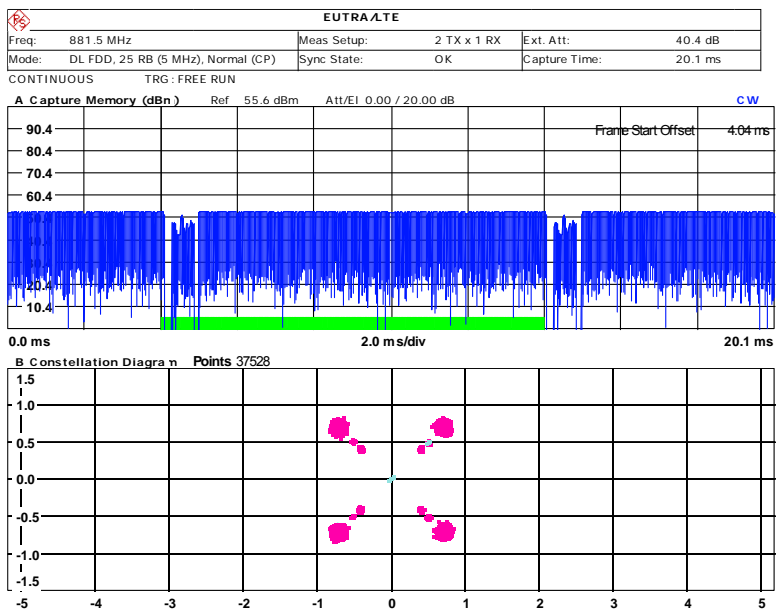

Date: 18.NOV.2011 12:27:12



E-TM3.2: EUT transmitting with 16QAM modulation:

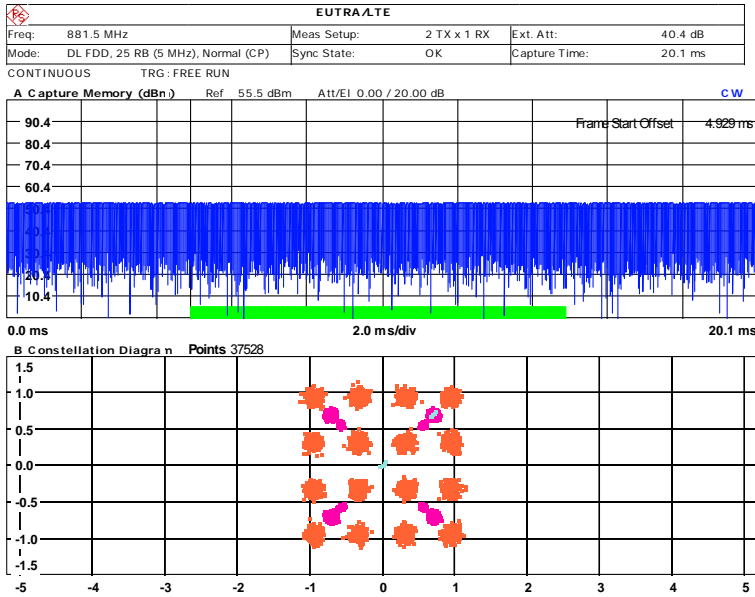

Date: 18.NOV.2011 12:24:55

E-TM3.1: EUT transmitting with 64QAM modulation:

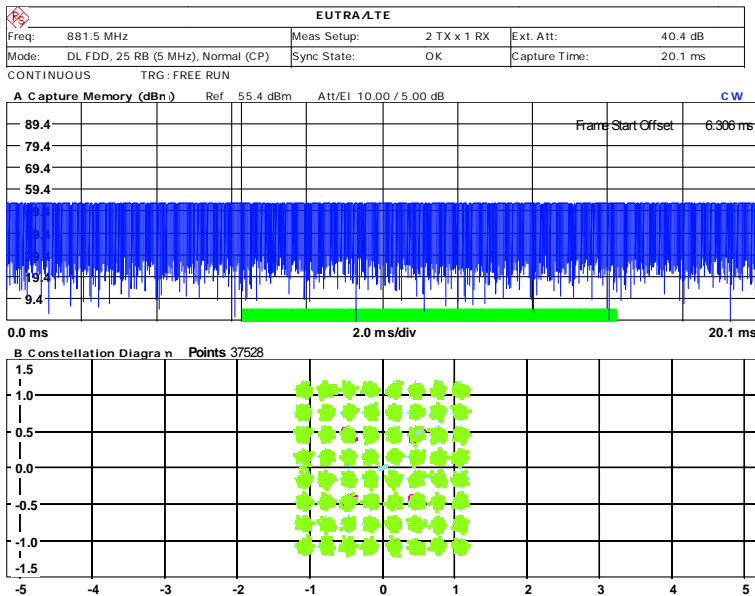

Date: 18.NOV.2011 12:21:26



Product Service

2.4 OCCUPIED BANDWIDTH

2.4.1 Specification Reference

FCC CFR 47 Part 2, Clause 2.1049 (h)
 FCC CFR 47 Part 22, Clause 22.917 (b)
 Industry Canada RSS-GEN, Clause 4.6.1

2.4.2 Equipment Under Test

RRUS 11 B5 / KRC 161 285/2, S/N: CB4L317562

2.4.3 Date of Test and Modification State

18, 21 and 29 November 2011 – Modification State 0

2.4.4 Test Equipment Used

The major items of test equipment used for the above tests are identified in Section 3.1.

2.4.5 Test Method and Operating Modes

The test was applied in accordance with the test method requirements of FCC CFR 47 Part 2 and Part 22 and Industry Canada RSS-GEN.

The EUT was transmitting at maximum power, modulated using the test models described. The EUT was tested in the 6 supported bandwidths. At least 1% of the emission bandwidths were used for the resolution bandwidth.

The occupied bandwidth, that is the frequency bandwidth such that, below its lower and above its upper frequency limits, the mean powers radiated are each equal to 0.5 percent of the total mean power radiated by a given emission.

The test was performed with the EUT in the following configurations and modes of operation:

Configuration 1 - Mode 1 - 1.4, Mode 1 - 20
 - Mode 2 (1.4MHz, 3.0MHz, 5.0MHz, 10.0MHz, 15.0MHz, 20MHz OBW)
 - Mode 3 - 1.4, Mode 3 - 20

2.4.6 Environmental Conditions

	18 November 2011	21 November 2011	29 November 2011
Ambient Temperature	29.8°C	26.0°C	22.7°C
Relative Humidity	41.0%	21.0%	22.0%



2.4.7 Test Results

For the period of test the EUT met the requirements of FCC CFR 47 Part 2 and Part 22 and Industry Canada RSS-GEN for Occupied Bandwidth.

The test results are shown below

Test Model	BW configuration (MHz)	Frequency (MHz) / Channel	Occupied Bandwidth (MHz)
E-TM1.1	1.4	869.7 (Bottom)	1.09
	20.0	879.0 (Bottom)	17.87
	1.4	881.5 (Middle)	1.09
	3.0	881.5 (Middle)	2.70
	5.0	881.5 (Middle)	4.47
	10.0	881.5 (Middle)	8.97
	15.0	881.5 (Middle)	13.46
	20.0	881.5 (Middle)	17.87
	1.4	893.3 (Top)	1.09
	20.0	884.0 (Top)	17.87
E-TM3.2	1.4	881.5 (Middle)	1.09
	20.0	881.5 (Middle)	17.87
E-TM3.1	1.4	881.5 (Middle)	1.09
	20.0	881.5 (Middle)	17.87



E-TM1.1

Configuration 1 - Mode 1 - 1.4

1.4MHz Bandwidth

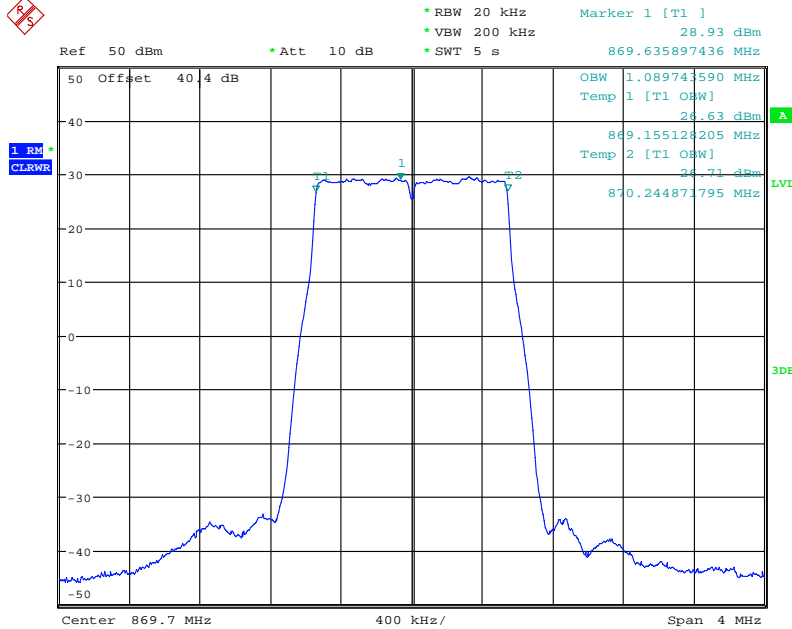

Date: 18.NOV.2011 15:50:19

Configuration 1 - Mode 1 - 20

20.0MHz Bandwidth

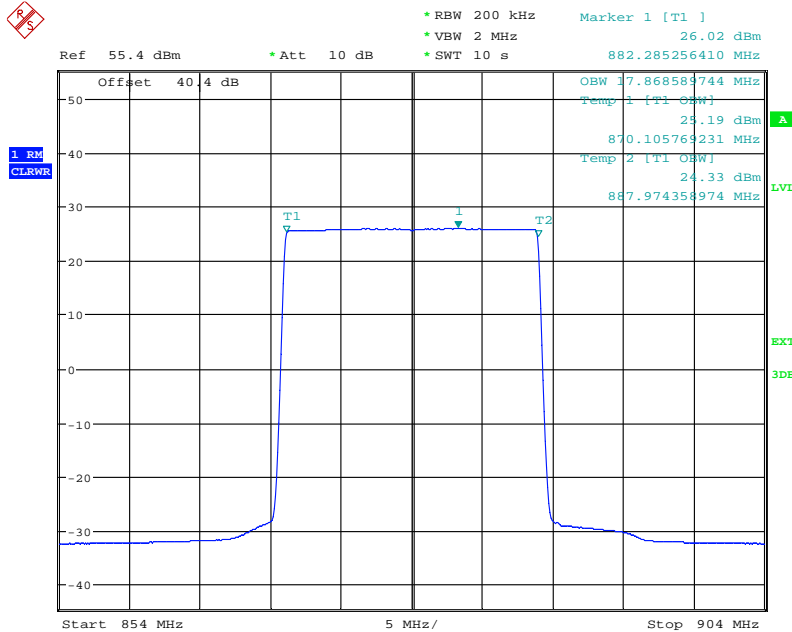

Date: 29.NOV.2011 04:05:08



Configuration 1 - Mode 2

1.4MHz Bandwidth

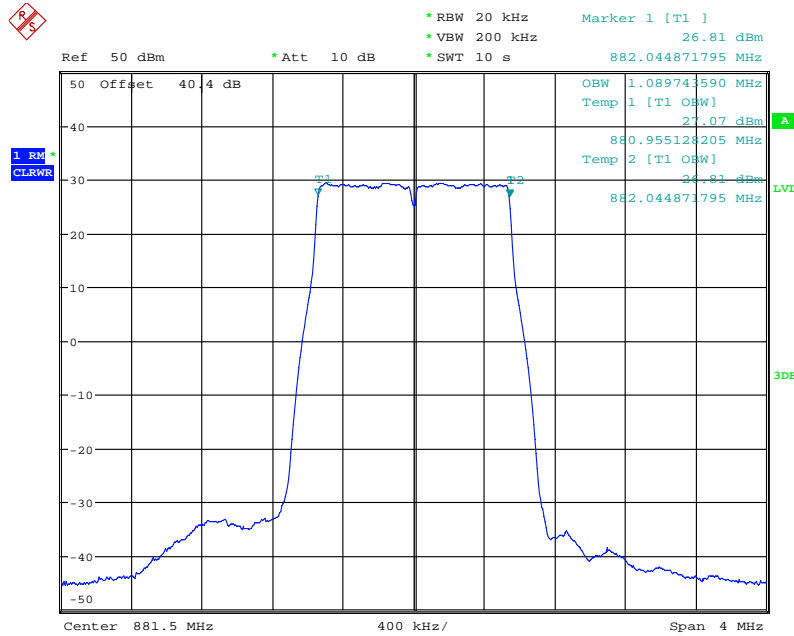

Date: 18.NOV.2011 09:30:02

3.0MHz Bandwidth

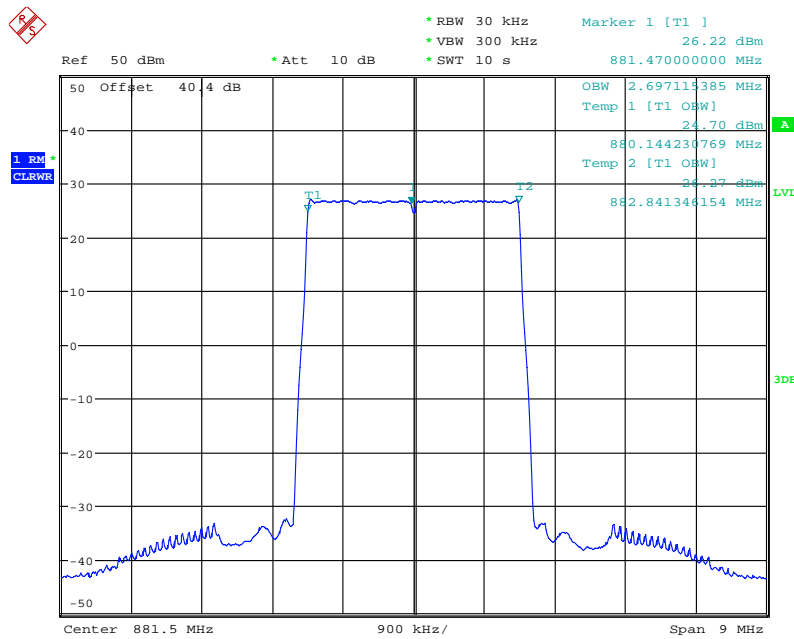

Date: 21.NOV.2011 09:27:29



5.0MHz Bandwidth

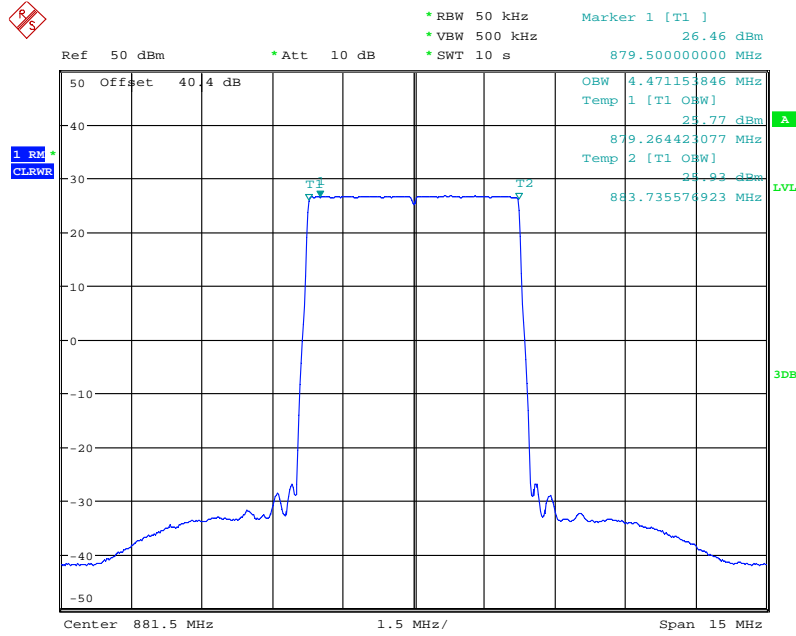

Date: 21.NOV.2011 09:20:06

10.0MHz Bandwidth

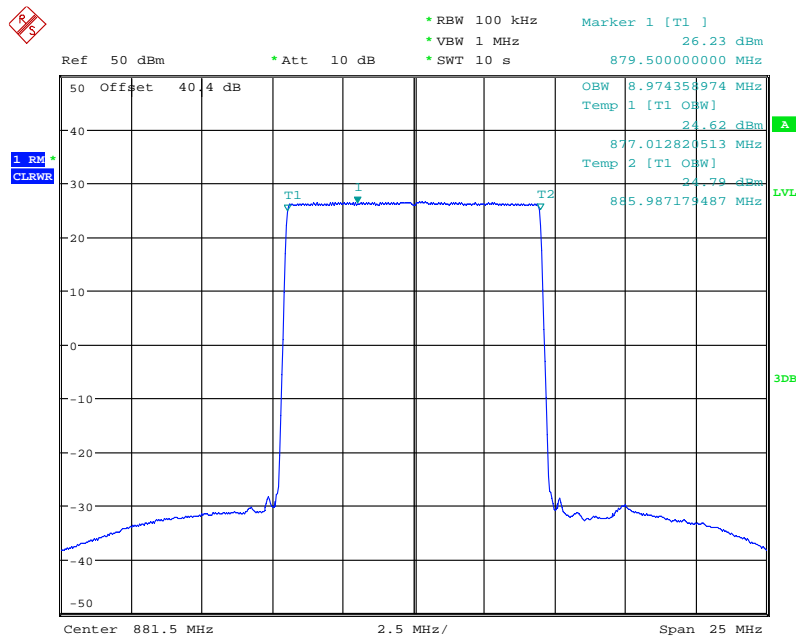

Date: 21.NOV.2011 08:51:07



15.0MHz Bandwidth

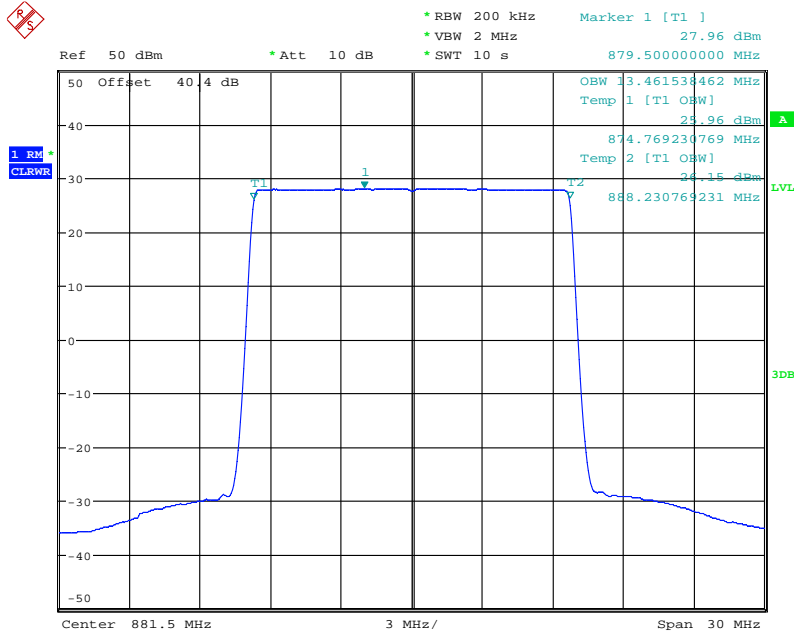

Date: 21.NOV.2011 08:56:15

20.0MHz Bandwidth

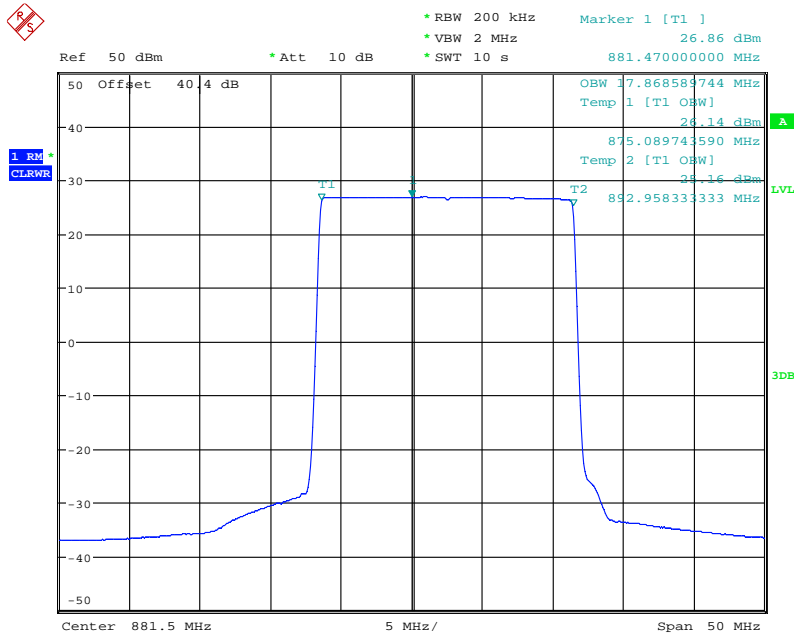

Date: 21.NOV.2011 11:28:01



Configuration 1 - Mode 3 - 1.4

1.4MHz Bandwidth

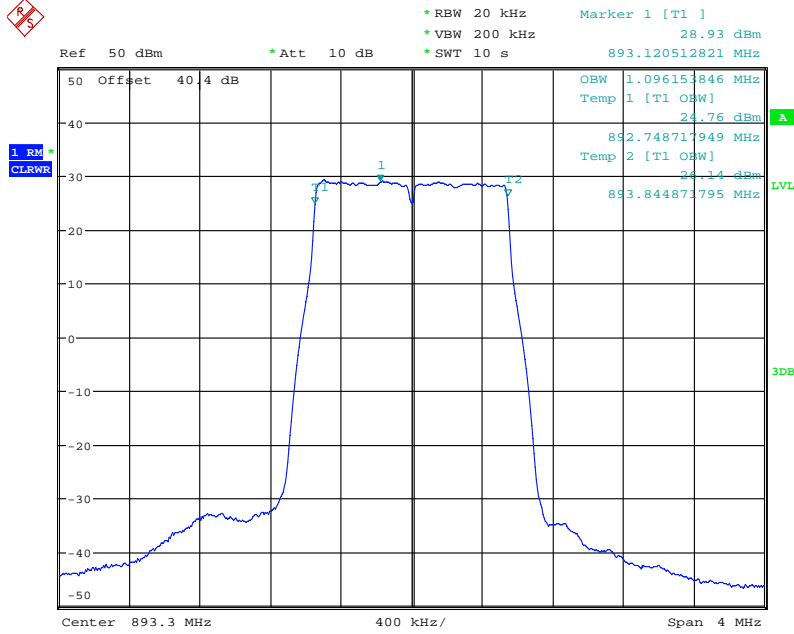

Date: 18.NOV.2011 15:04:34

Configuration 1 - Mode 3 - 20

20.0MHz Band

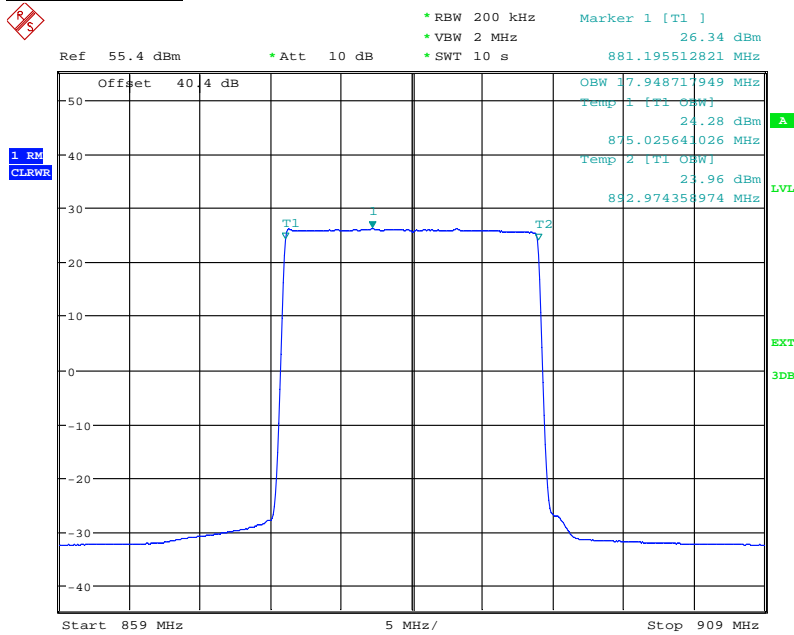

Date: 29.NOV.2011 04:10:07



E-TM3.2

Configuration 1 - Mode 2

1.4MHz Bandwidth

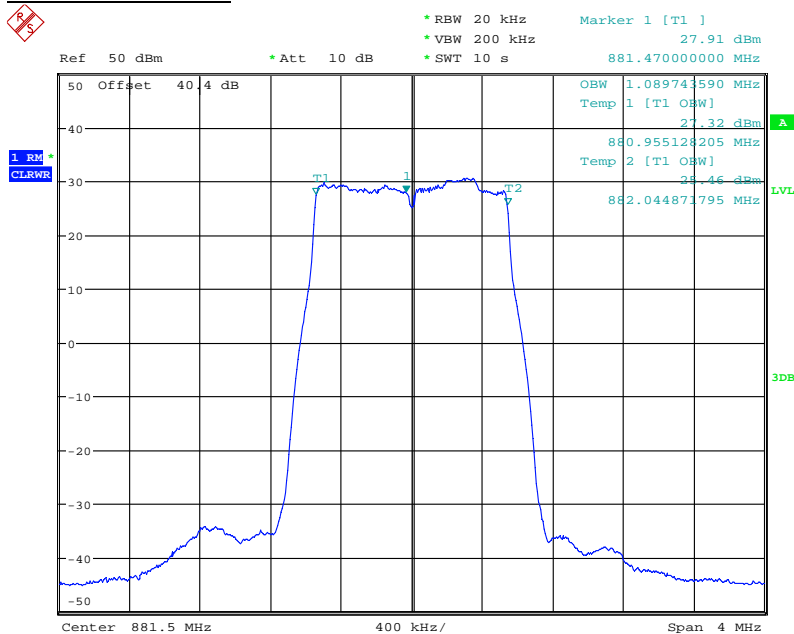

Date: 21.NOV.2011 09:39:16

20MHz Bandwidth

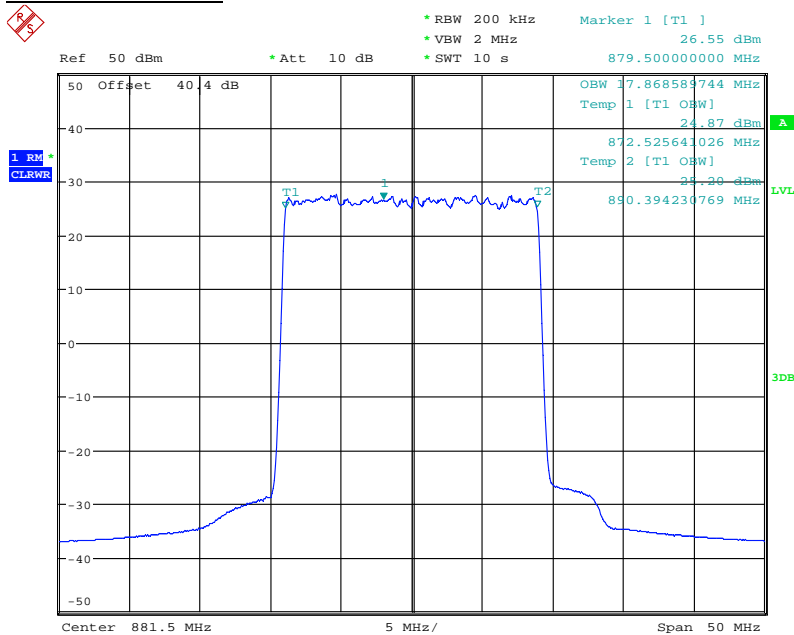

Date: 21.NOV.2011 09:07:12



E-TM3.1

Configuration 1 - Mode 2

1.4MHz Bandwidth

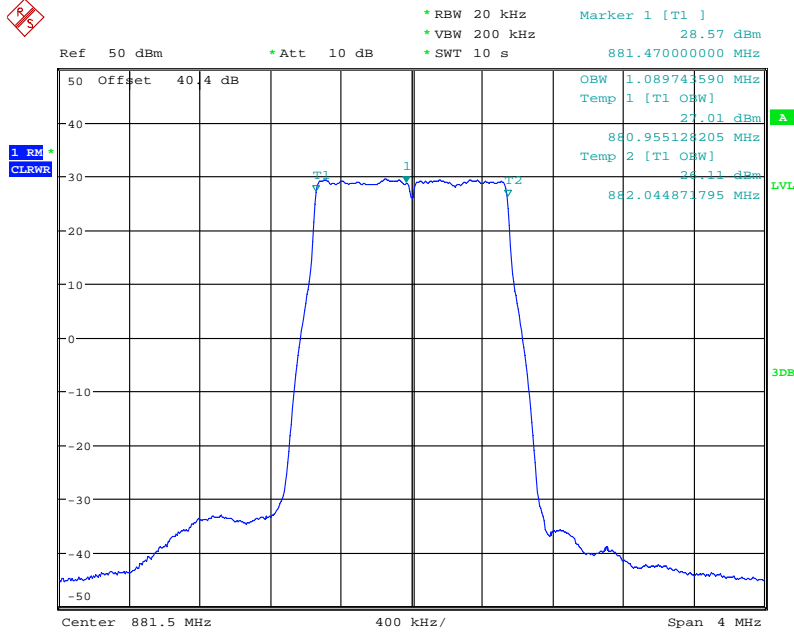

Date: 21.NOV.2011 09:57:17

20MHz Bandwidth

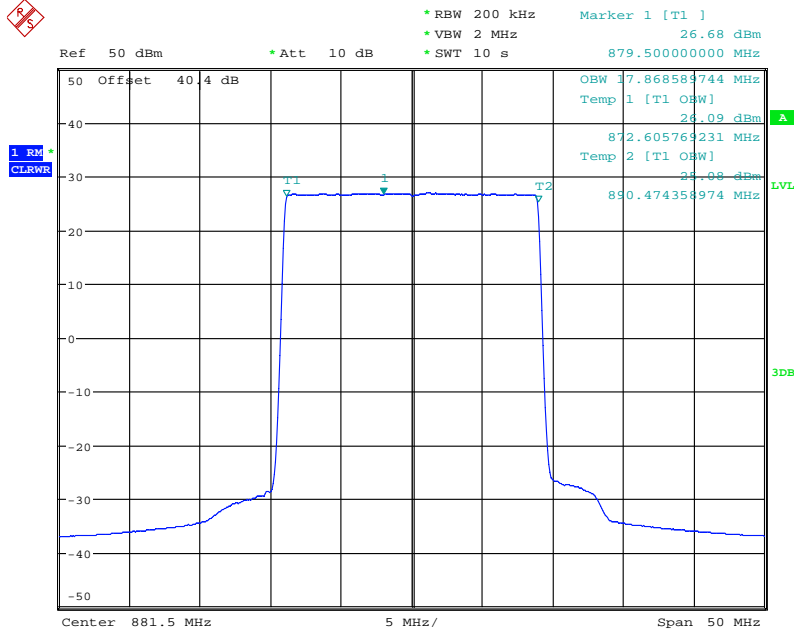

Date: 21.NOV.2011 09:13:37



Product Service

2.5 SPURIOUS EMISSIONS AT ANTENNA TERMINALS (± 1 MHz)

2.5.1 Specification Reference

FCC CFR 47 Part 2, Clause 2.1051
FCC CFR 47 Part 22, Clause 22.917 (b)
Industry Canada RSS-132 Clause 4.5

2.5.2 Equipment Under Test

RRUS 11 B5 / KRC 161 285/2, S/N: CB4L317562

2.5.3 Date of Test and Modification State

21, 22 and 29 November 2011 – Modification State 0

2.5.4 Test Equipment Used

The major items of test equipment used for the above tests are identified in Section 3.1.

2.5.5 Test Method and Operating Modes

The test was applied in accordance with the test method requirements of FCC CFR 47 Part 2 and Part 22 and Industry Canada RSS-132.

Since the EUT transmits on two antennas simultaneously in the same frequency range, i.e. TX Diversity, using the Measure and Add $10\log(N)$ dB technique, the limits for spurious emissions at antenna terminals (± 1 MHz) should be adjusted with a correction of $10\log 2$.

In accordance with 22.917(b), at least 1% of the emission bandwidth was used for the resolution bandwidth up to 1MHz away from the block edge. The limit -13dBm was adjusted with a correction of $10\log 2$ to -16dBm . A resolution bandwidth of 50kHz was used between 1MHz to 5MHz away from the band edge. As the Industry Canada rules specify a RBW of 1MHz for measurements of emissions > 1 MHz away from the band edges, the limit was adjusted with $(-13\text{dB} - 10\log 2)$ to -29dBm to compensate for the reduced measurement bandwidth. Spectrum analyzer detector was set as RMS.

The path loss measured and entered as a reference level offset.

The EUT was tested at its maximum power level.

The test was performed with the EUT in the following configurations and modes of operation:

Configuration 1 - Mode 1 - 1.4, Mode 1 - 3, Mode 1 - 5,
Mode 1 - 10, Mode 1 - 15, Mode 1 - 20

- Mode 3 - 1.4, Mode 3 - 3, Mode 3 - 5,
Mode 3 - 10, Mode 3 - 15, Mode 3 - 20



2.5.6 Environmental Conditions

	21 November 2011	22 November 2011	29 November 2011
Ambient Temperature	26.0°C	24.0°C	22.7°C
Relative Humidity	21.0%	27.5%	22.0%

2.5.7 Test Results

For the period of test the EUT met the requirements of FCC CFR 47 Part 2 and Part 22 and Industry Canada RSS-132 for Spurious Emissions Antenna Terminals (± 1 MHz)

Below are the Frequencies the EUT was tested against along with the tested channels.

Antenna A and B

ETM1.1:

1.4MHz Bandwidth

Configuration 1 - Mode 1 -1.4 and Mode 3 - 1.4

Band Edge Frequency	Edge Test with 1.4MHz Bandwidth Channel No./Frequencies	RBW / VBW (Hz)
Bottom 869 MHz	Channel: 2407 Frequency: 869.7 MHz	20k / 200k
Top 894MHz	Channel: 2643 Frequency: 893.3 MHz	

3.0MHz Bandwidth

Configuration 1 - Mode 1 - 3 and Mode 3 - 3

Band Edge Frequency	Edge Test with 3.0MHz Bandwidth Channel No./Frequencies	RBW / VBW (Hz)
Bottom 869 MHz	Channel: 2415 Frequency: 870.5 MHz	30k / 300k
Top 894MHz	Channel: 2635 Frequency: 892.5MHz	

5.0MHz Bandwidth

Configuration 1 - Mode 1 - 5 and Mode 3 - 5

Band Edge Frequency	Edge Test with 5.0MHz Bandwidth Channel No./Frequencies	RBW / VBW (Hz)
Bottom 869 MHz	Channel: 2425 Frequency: 871.5 MHz	50k / 500k
Top 894MHz	Channel: 2625 Frequency: 891.5 MHz	



10.0MHz Bandwidth

Configuration 1 - Mode 1 - 10 and Mode 3 - 10

Band Edge Frequency	Edge Test with 10.0MHz Bandwidth Channel No./Frequencies	RBW / VBW (Hz)
Bottom 869 MHz	Channel: 2450 Frequency: 874.0 MHz	100k / 1M
Top 894MHz	Channel: 2600 Frequency: 889.0 MHz	

15.0MHz Bandwidth

Configuration 1 - Mode 1 - 15 and Mode 3 - 15

Band Edge Frequency	Edge Test with 15.0MHz Bandwidth Channel No./Frequencies	RBW / VBW (Hz)
Bottom 869 MHz	Channel: 2475 Frequency: 876.5 MHz	200k / 2M
Top 894MHz	Channel: 2575 Frequency: 886.5 MHz	

20.0MHz Bandwidth

Configuration 1 - Mode 1 - 20 and Mode 3 - 20

Band Edge Frequency	Edge Test with 20.0MHz Bandwidth Channel No./Frequencies	RBW / VBW (Hz)
Bottom 869 MHz	Channel: 2500 Frequency: 879.0 MHz	200k / 2M
Top 894MHz	Channel: 2550 Frequency: 884.0 MHz	

The channels shown in the table above are the minimum and maximum channels that can be used in the authorised frequency ranges to maintain compliance.



The test results are shown below

Antenna A

E-TM1.1

1.4MHz Bandwidth

Configuration 1 - Mode 1 - 1.4

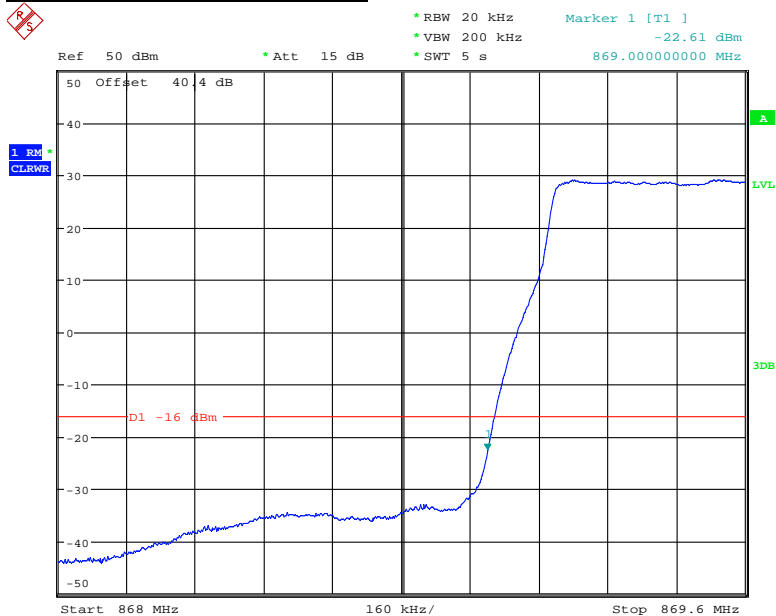

Date: 21.NOV.2011 11:53:47

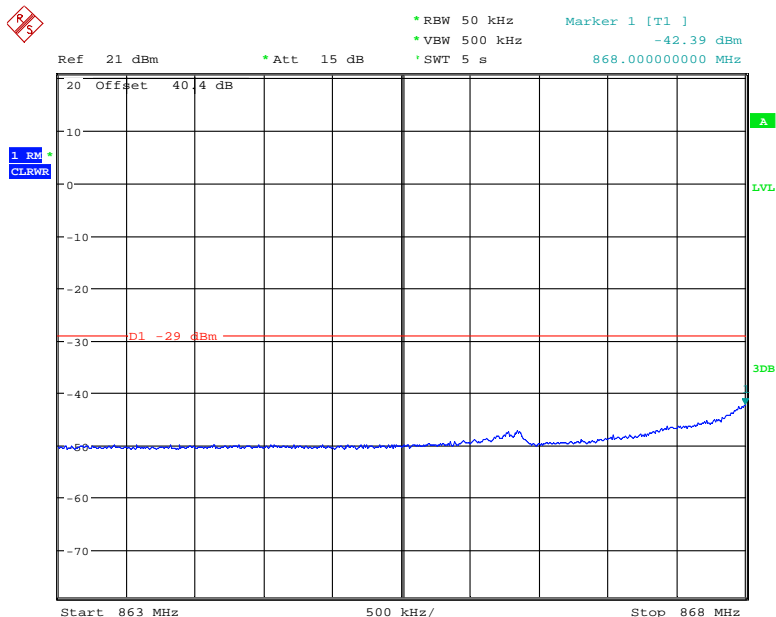

Date: 21.NOV.2011 11:59:43



Configuration 1 - Mode 3 - 1.4

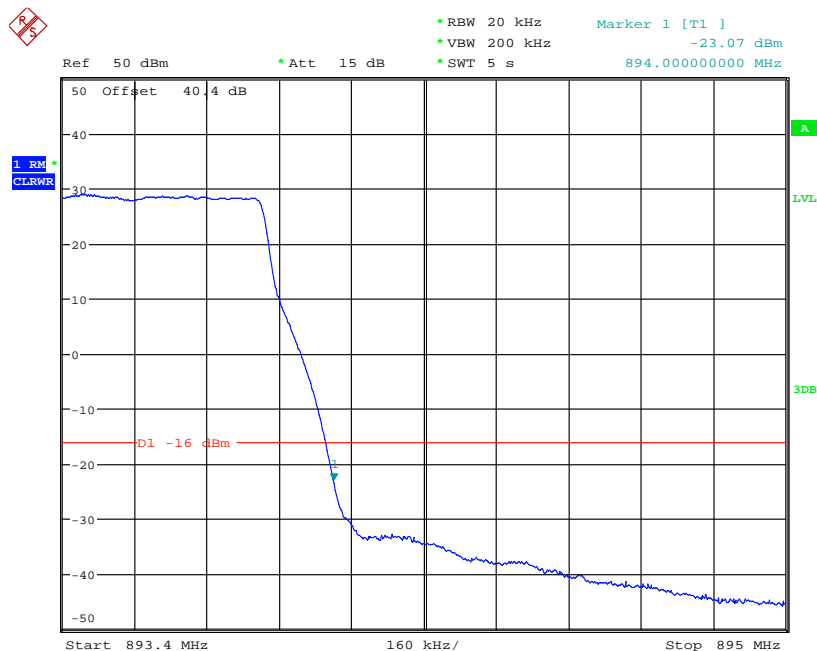

Date: 21.NOV.2011 12:25:58

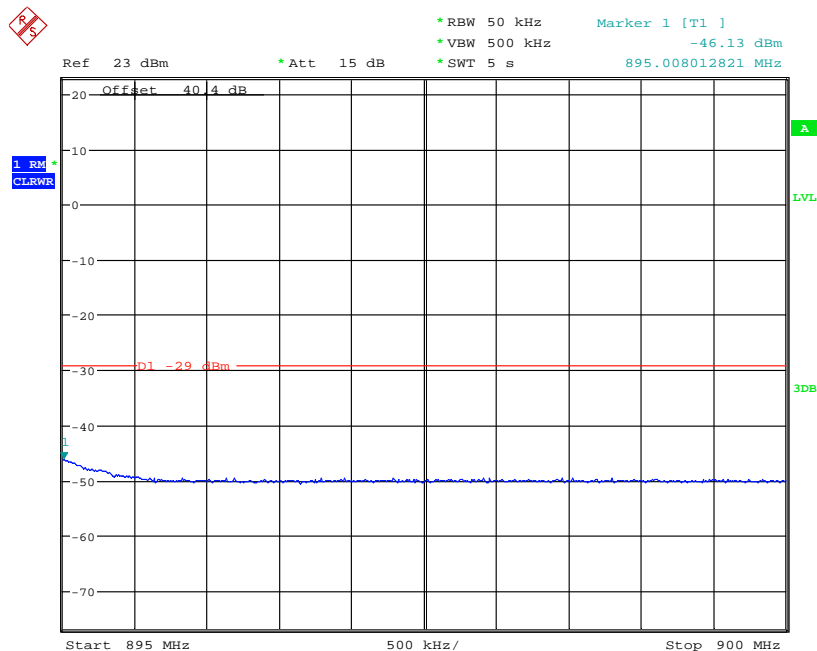

Date: 21.NOV.2011 12:19:38



3.0MHz Bandwidth

Configuration 1 - Mode 1 - 3

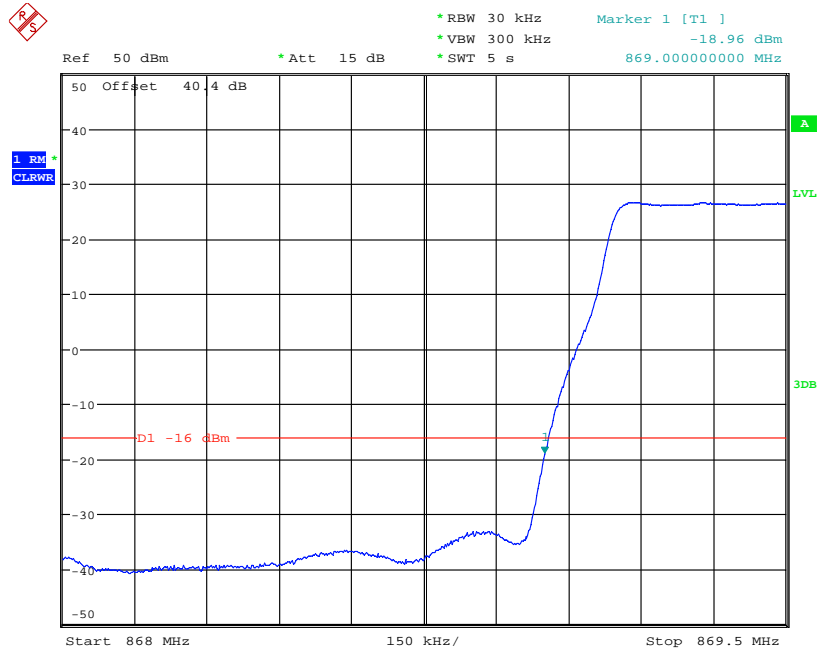

Date: 21.NOV.2011 12:32:37

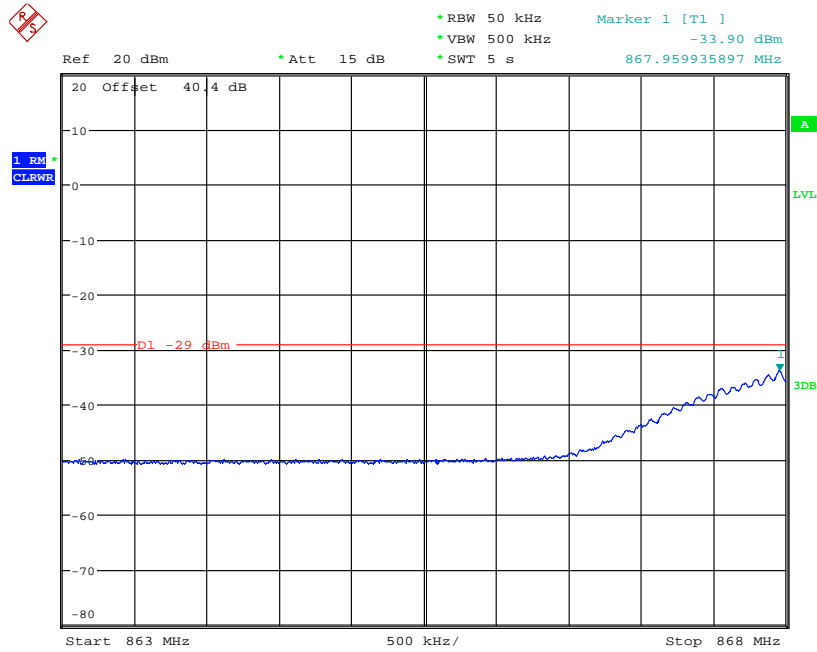

Date: 21.NOV.2011 12:37:28



Configuration 1 - Mode 3 - 3

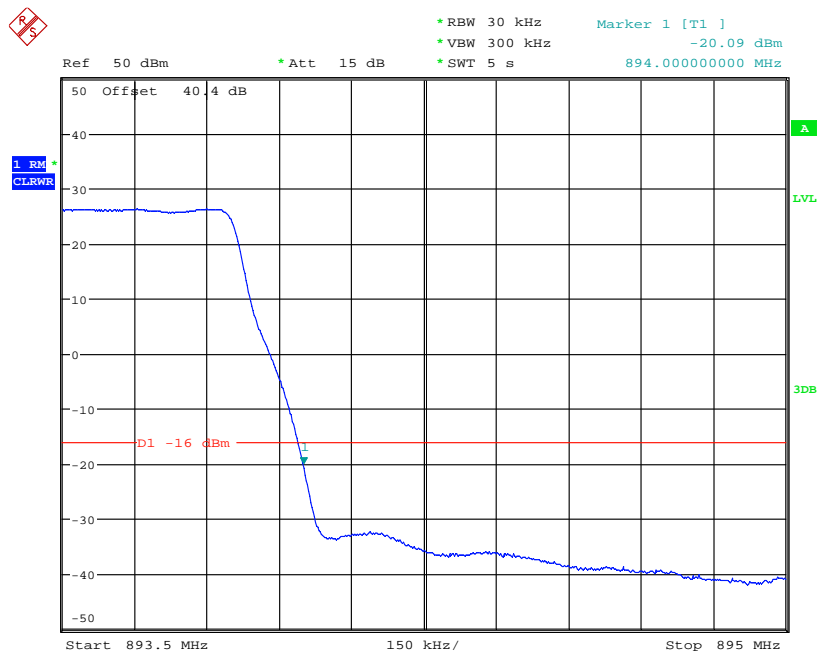

Date: 21.NOV.2011 12:45:21

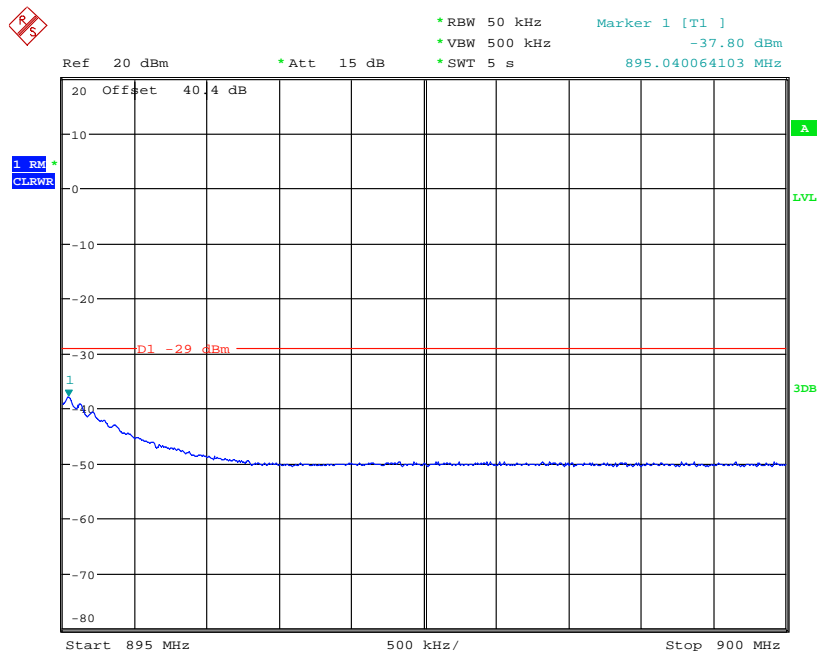

Date: 21.NOV.2011 12:41:09



5.0MHz Bandwidth

Configuration 1 - Mode 1 - 5

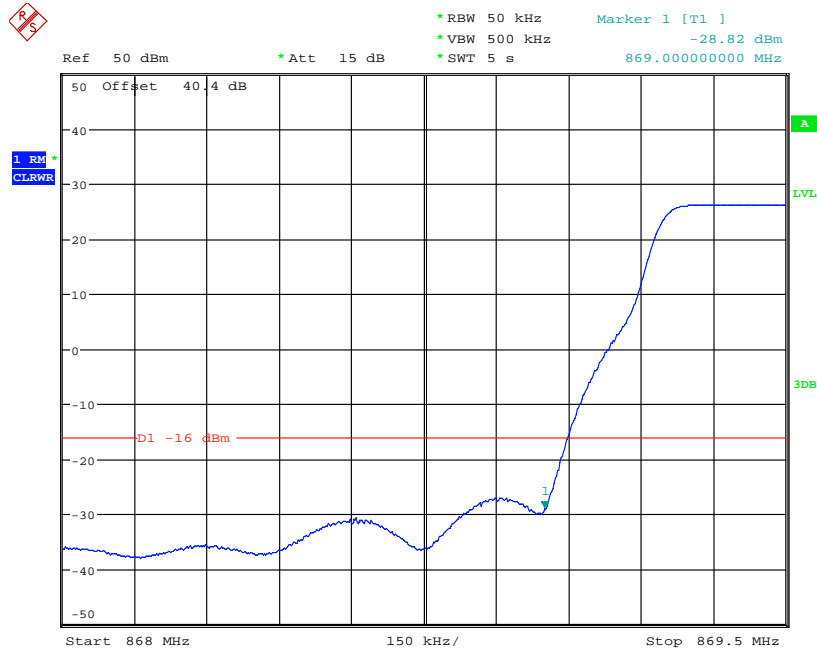

Date: 21.NOV.2011 12:50:58

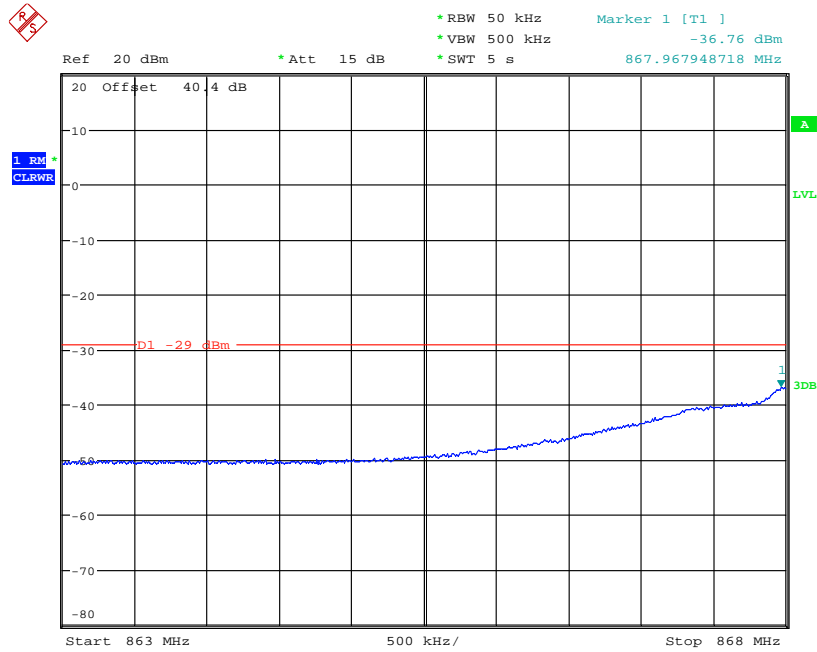

Date: 21.NOV.2011 12:52:50



Configuration 1 - Mode 3 - 5

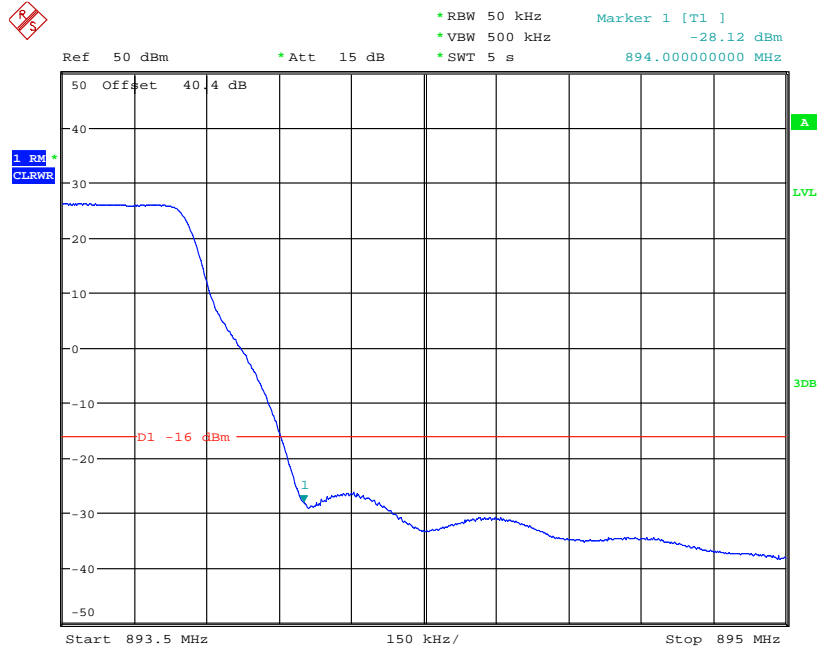

Date: 21.NOV.2011 13:22:48

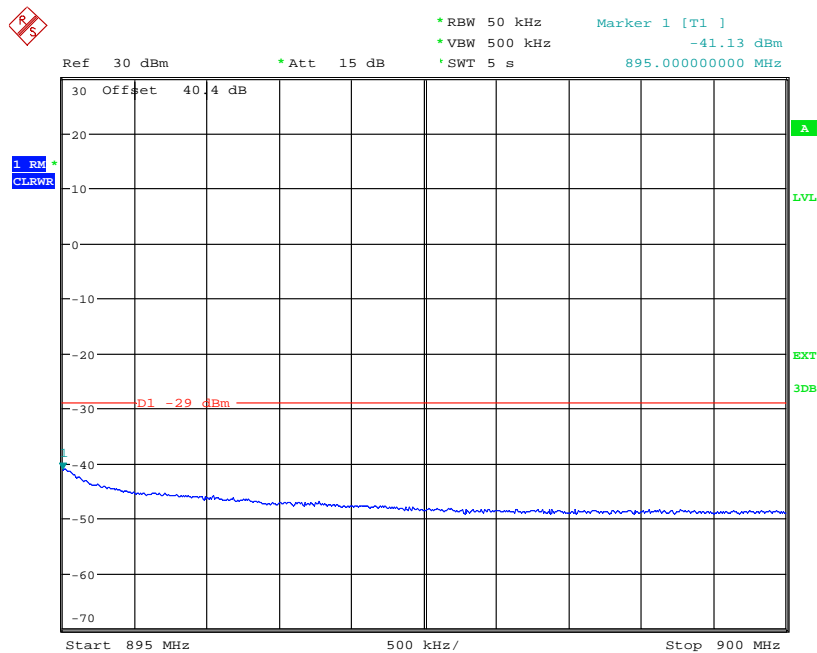

Date: 29.NOV.2011 04:18:27



10.0MHz Bandwidth

Configuration 1 - Mode 1 - 10

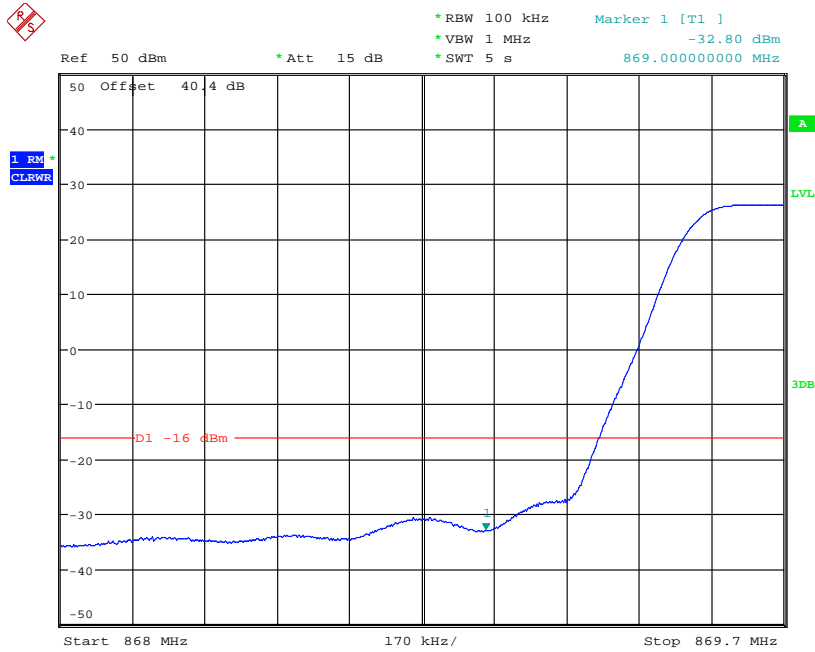

Date: 21.NOV.2011 13:46:48

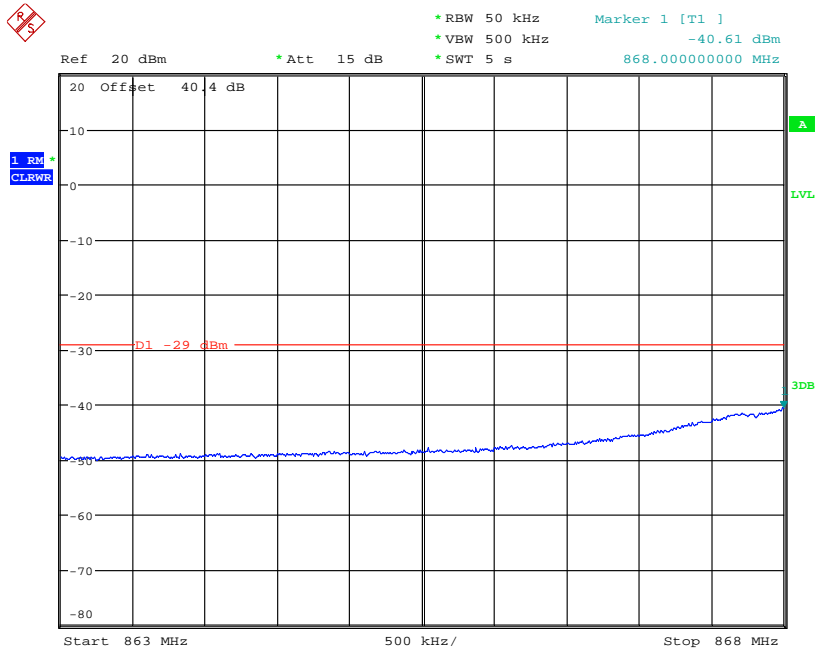

Date: 21.NOV.2011 13:42:41



Configuration 1 - Mode 3 - 10

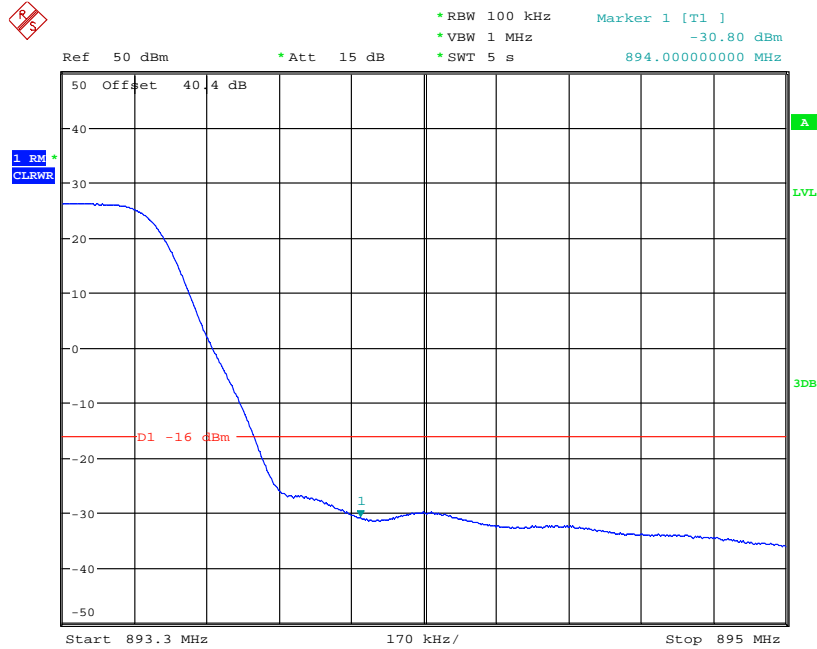

Date: 21.NOV.2011 13:52:17

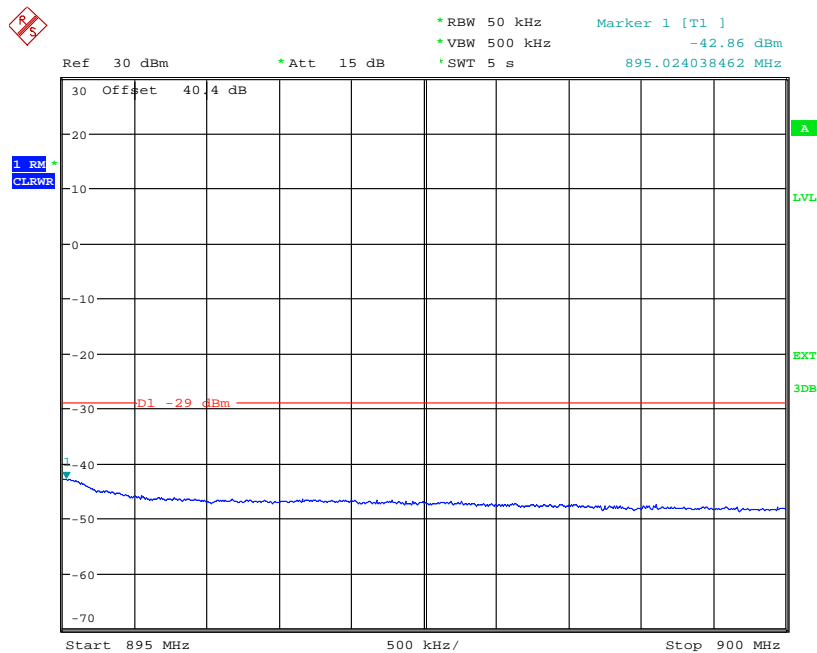

Date: 29.NOV.2011 04:22:47



15.0MHz Bandwidth

Configuration 1 - Mode 1 - 15

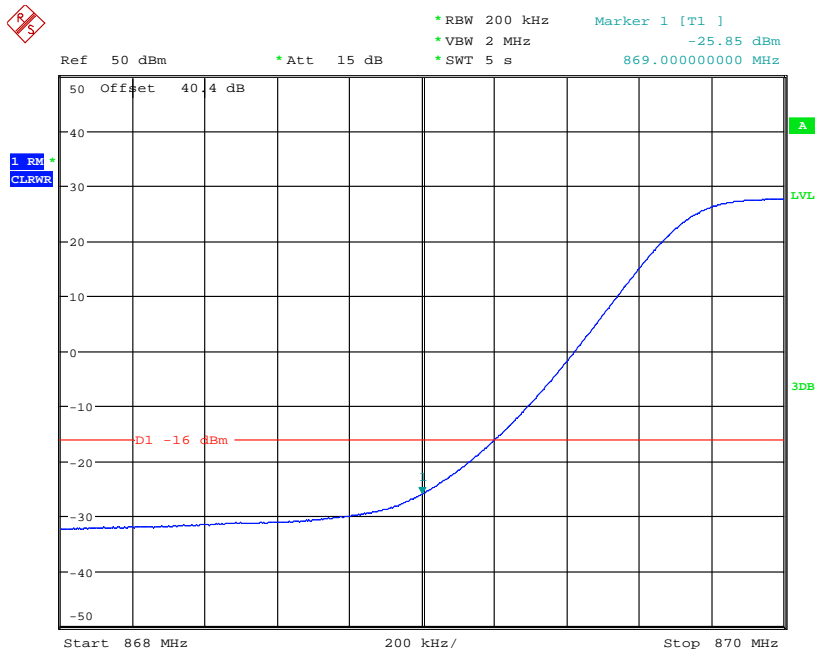

Date: 21.NOV.2011 14:07:23

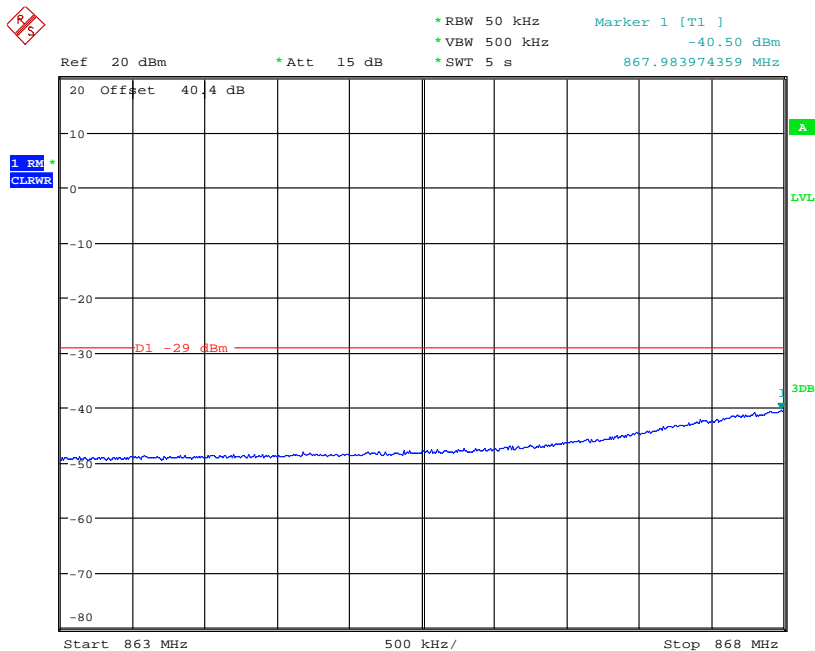

Date: 21.NOV.2011 14:09:23



Configuration 1 - Mode 3 - 15

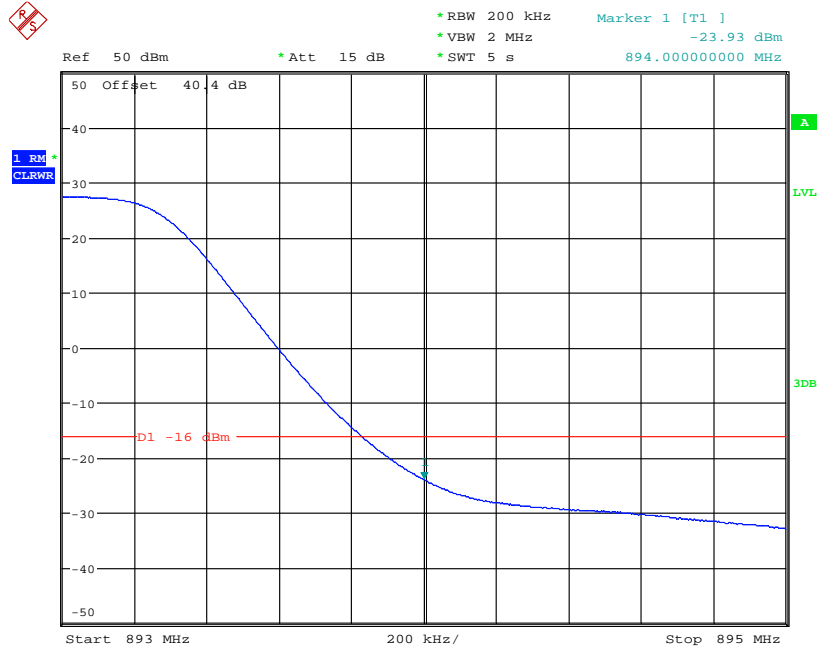

Date: 21.NOV.2011 14:13:32

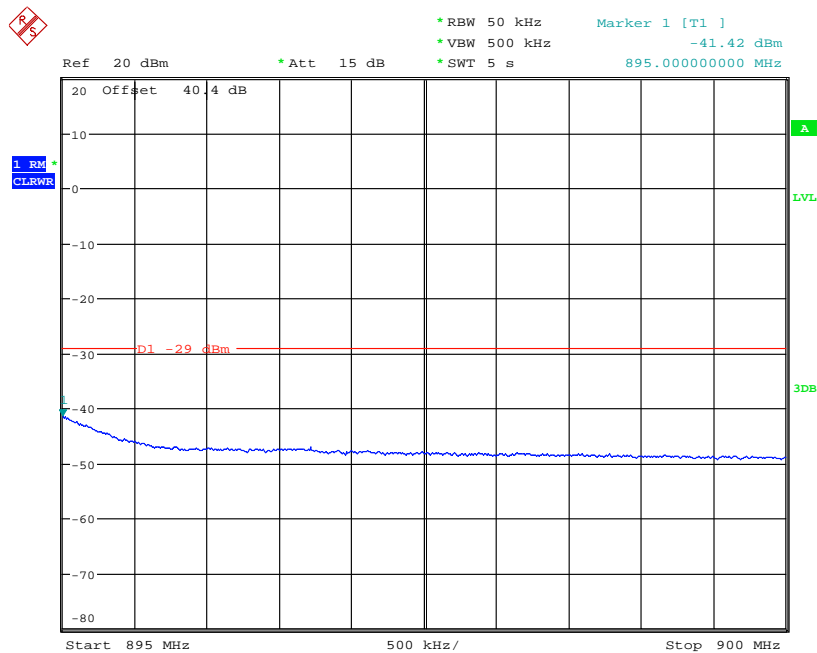

Date: 21.NOV.2011 14:11:38



20.0MHz Bandwidth

Configuration 1 - Mode 1 - 20

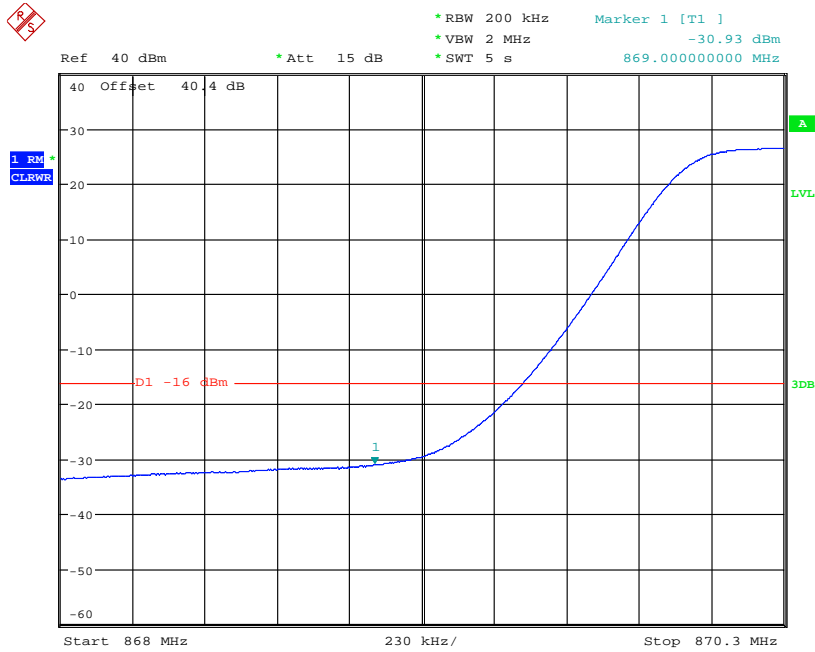

Date: 21.NOV.2011 11:50:18

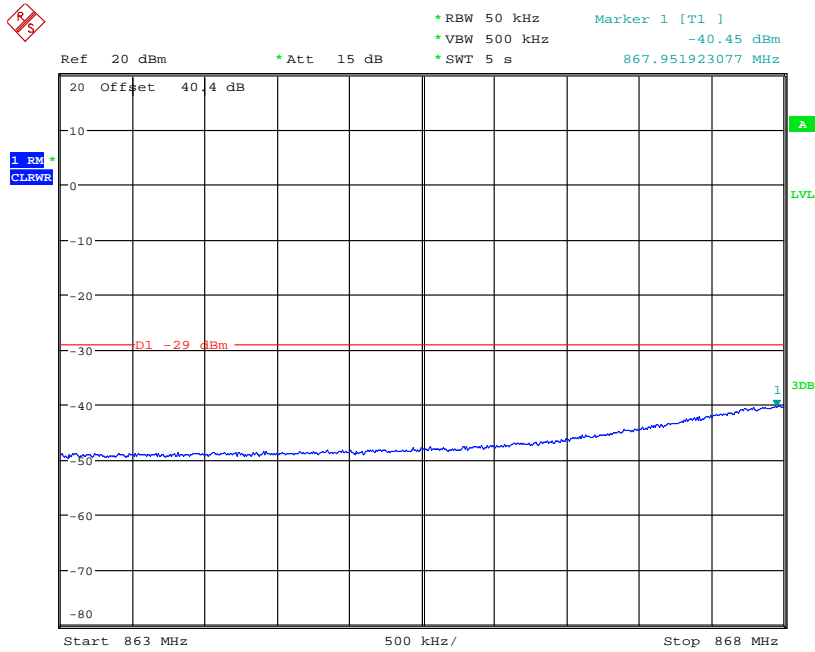

Date: 21.NOV.2011 11:48:50



Configuration 1 - Mode 3 - 20

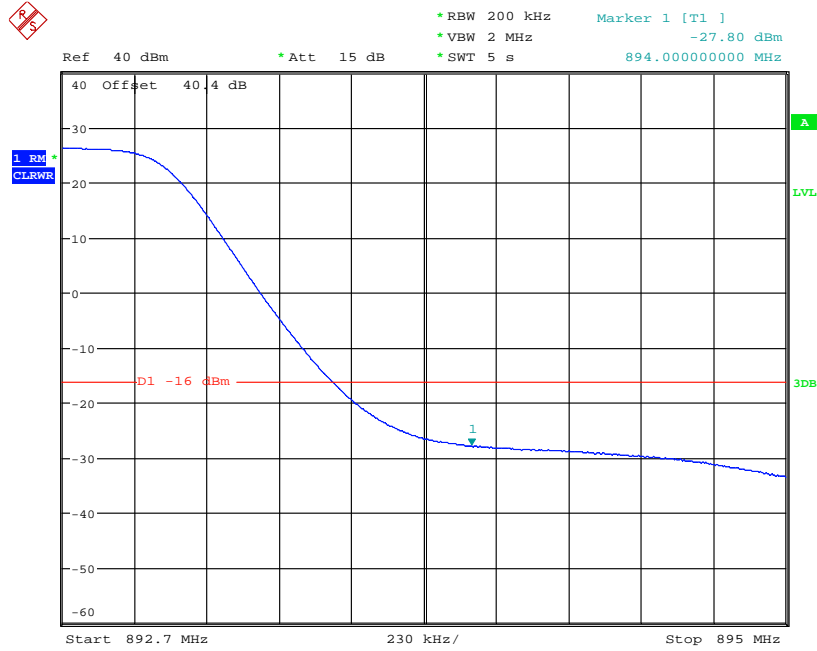

Date: 21.NOV.2011 11:44:36

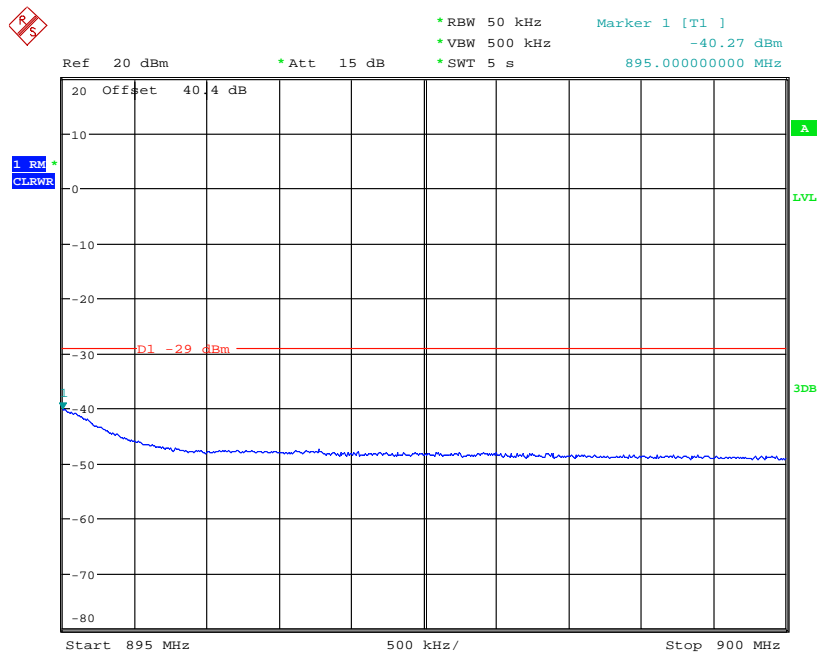

Date: 21.NOV.2011 11:45:34



Antenna B

E-TM1.1

1.4MHz Bandwidth

Configuration 1 - Mode 1 - 1.4

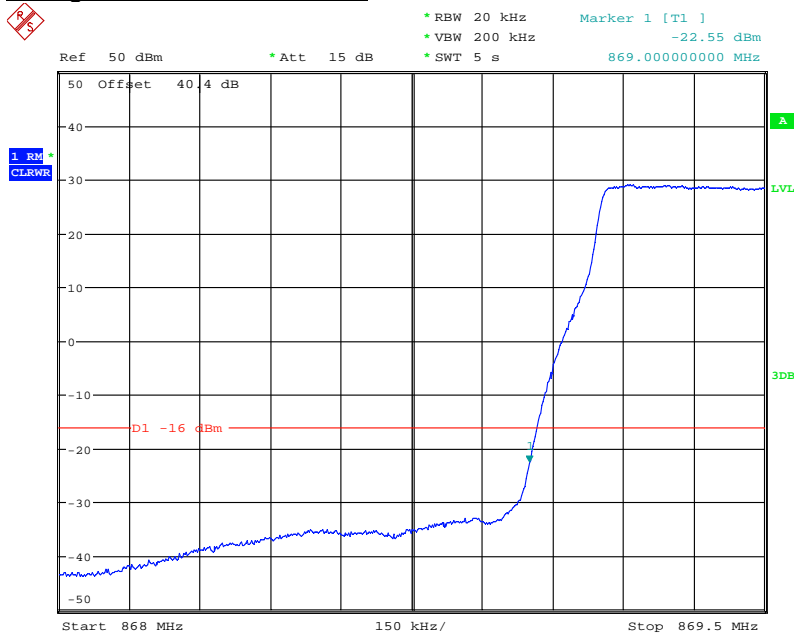

Date: 22.NOV.2011 10:00:31

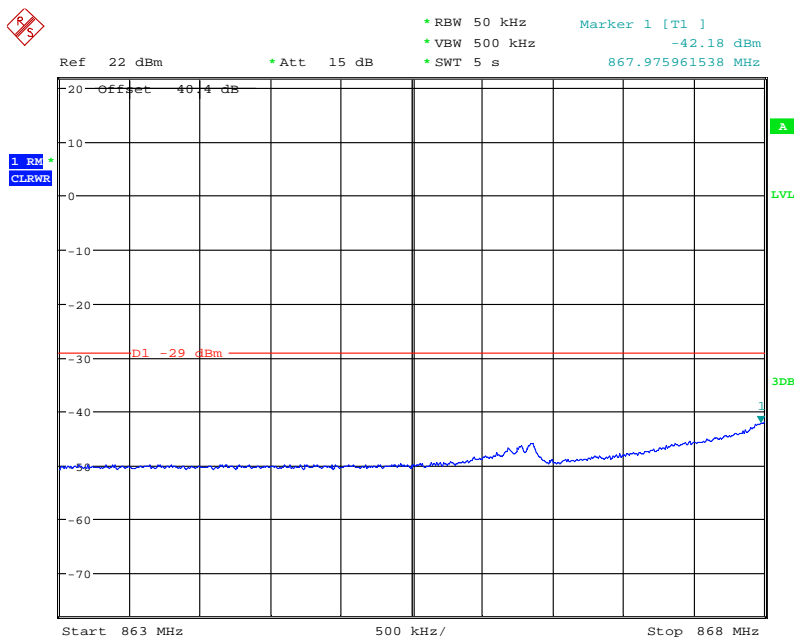

Date: 22.NOV.2011 10:02:51



Configuration 1 - Mode 3 - 1.4

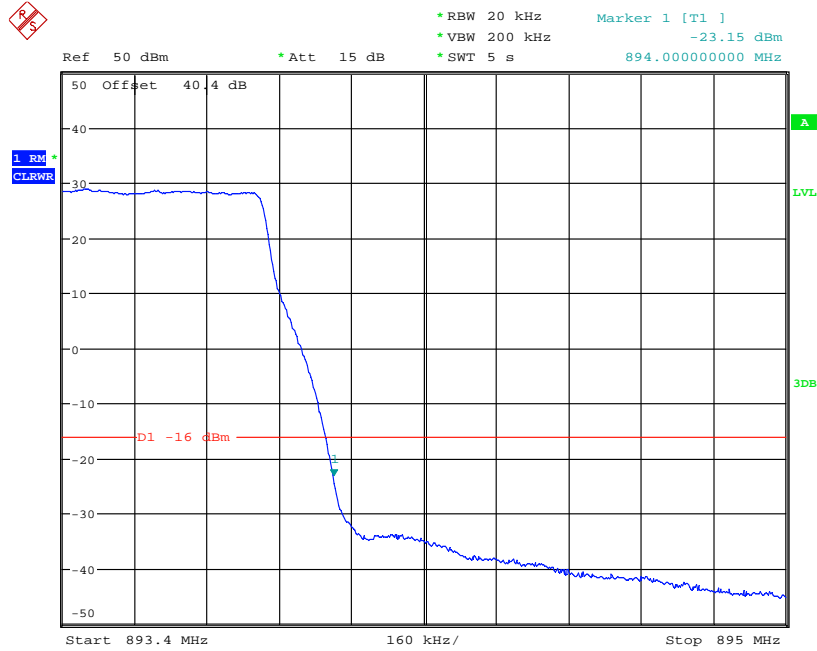

Date: 22.NOV.2011 10:07:02

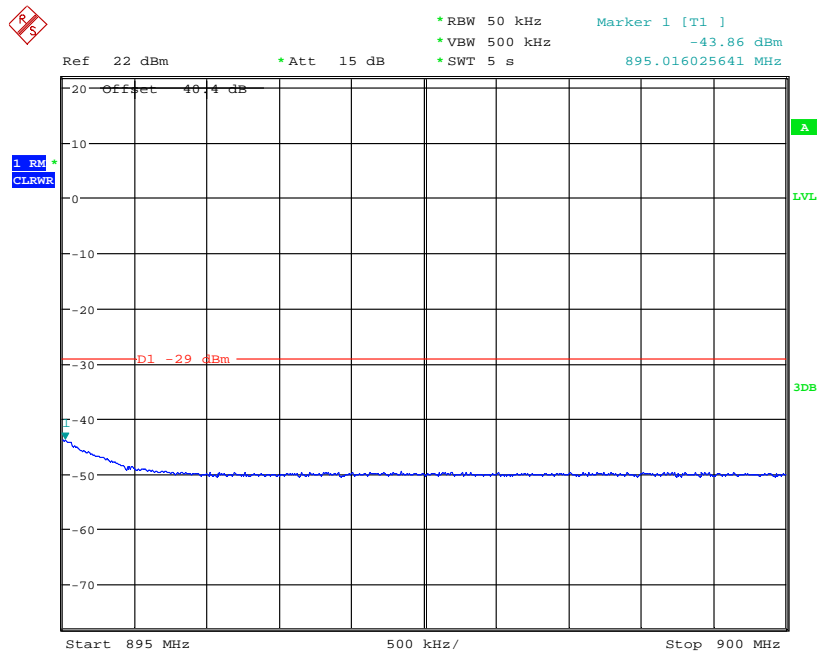

Date: 22.NOV.2011 10:04:34



3.0MHz Bandwidth

Configuration 1 - Mode 1 - 3

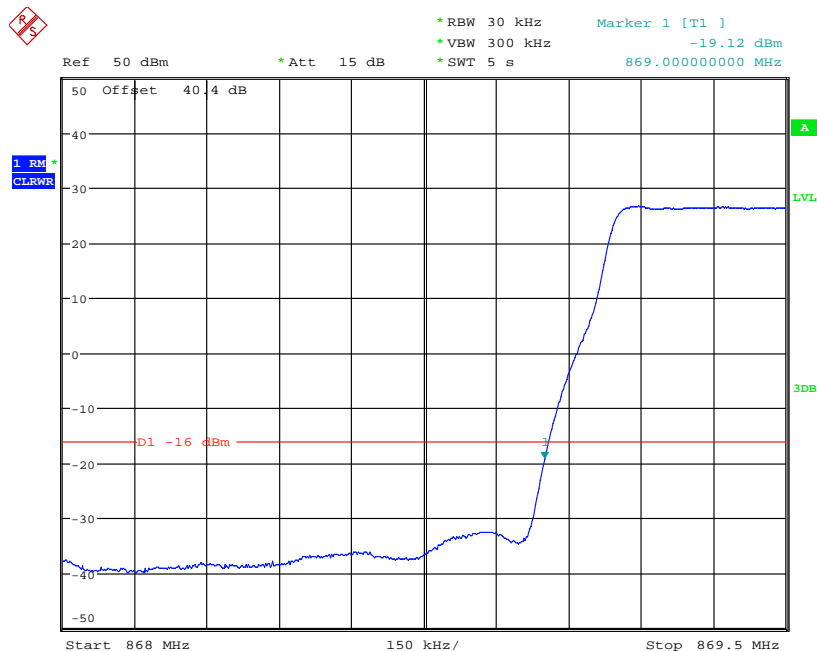

Date: 21.NOV.2011 15:15:44

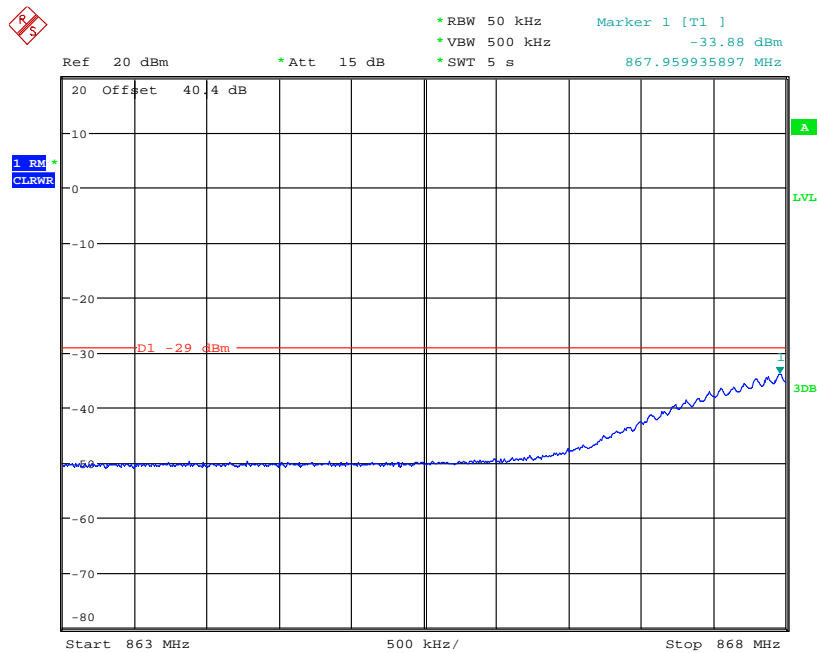

Date: 21.NOV.2011 15:17:44



Configuration 1 - Mode 3 - 3

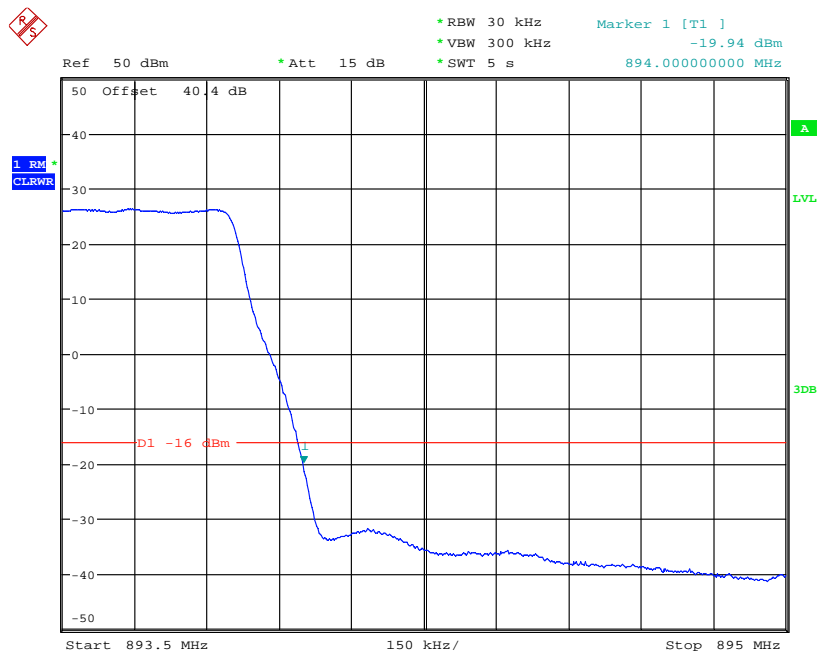

Date: 21.NOV.2011 15:26:36

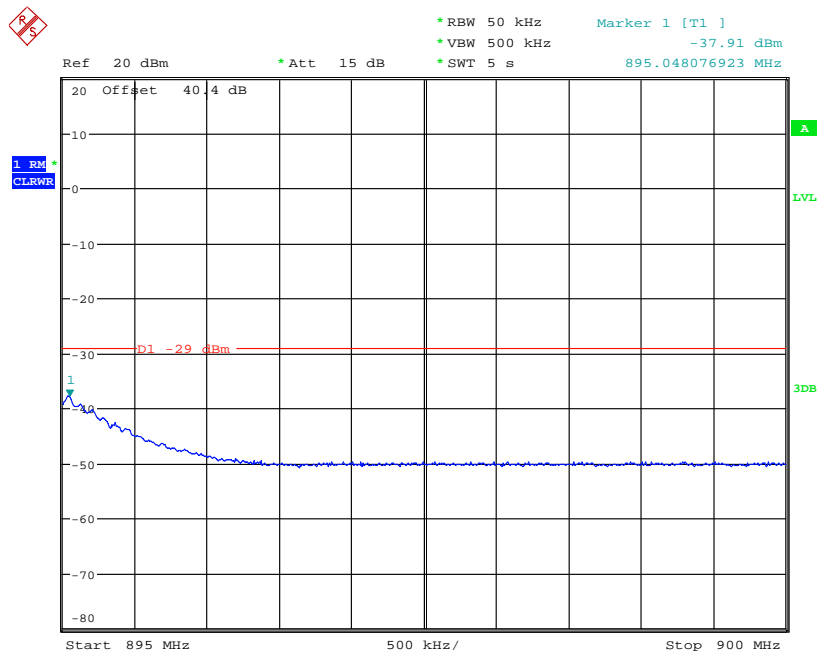

Date: 21.NOV.2011 15:24:22



5.0MHz Bandwidth

Configuration 1 - Mode 1 - 5

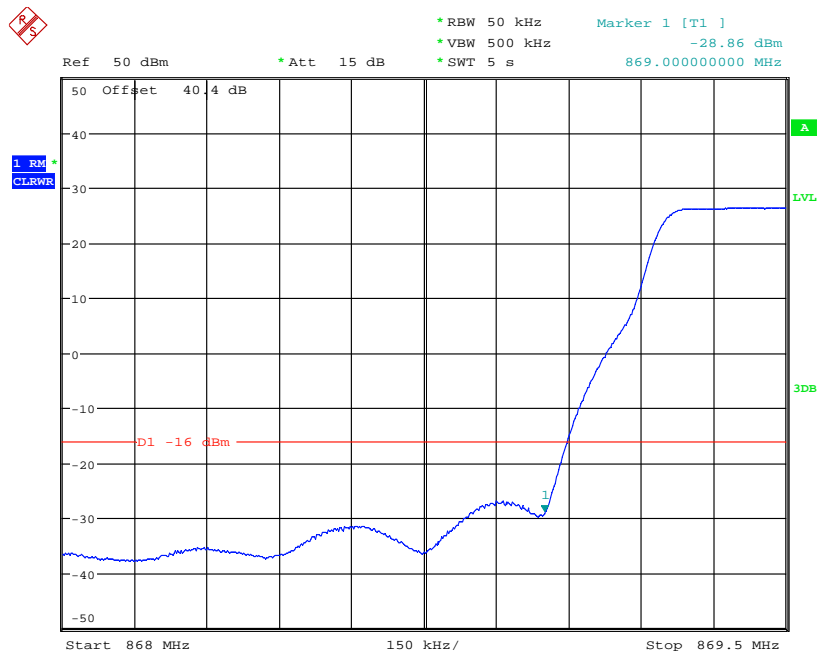

Date: 22.NOV.2011 09:55:16

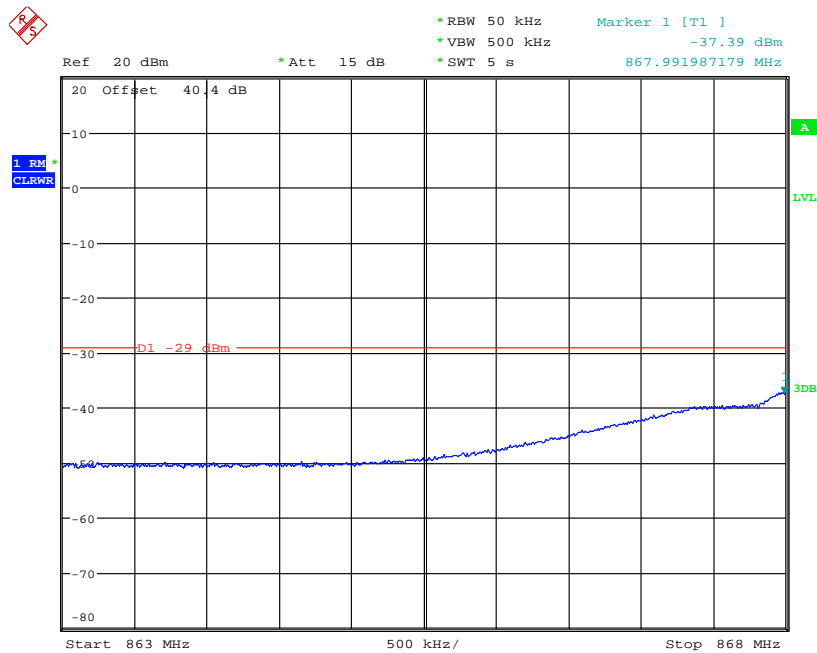

Date: 22.NOV.2011 09:52:27



Configuration 1 - Mode 3 - 5

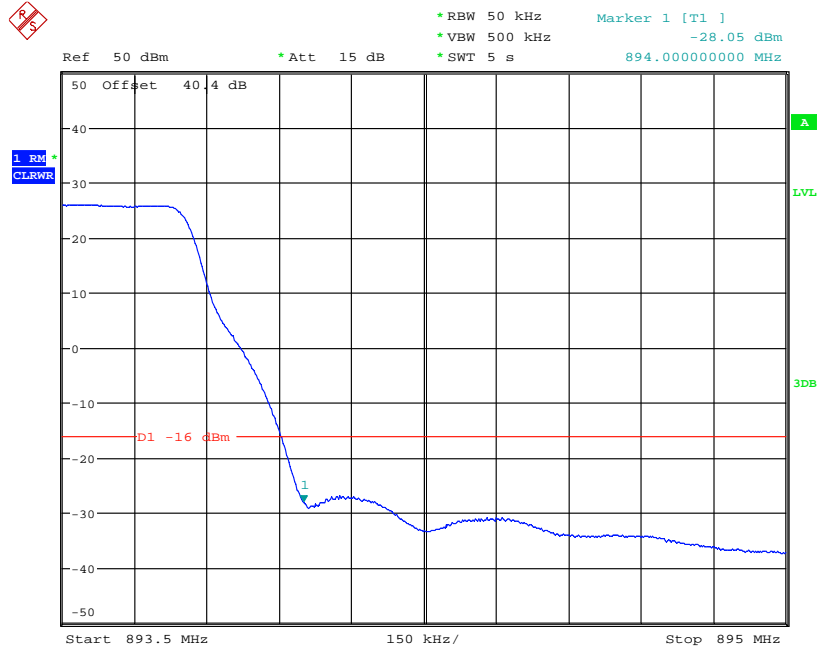

Date: 21.NOV.2011 15:39:50

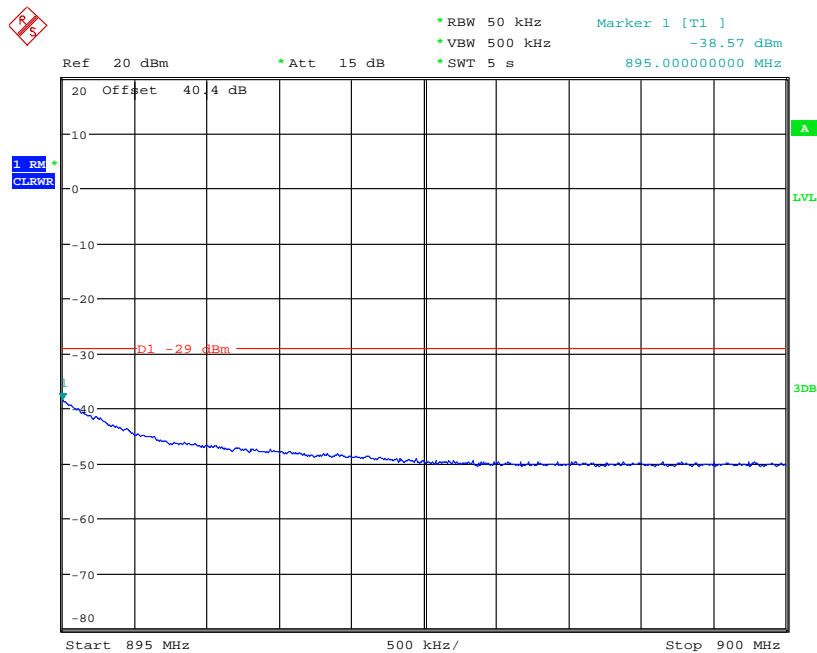

Date: 21.NOV.2011 15:41:24



10.0MHz Bandwidth

Configuration 1 - Mode 1 - 10

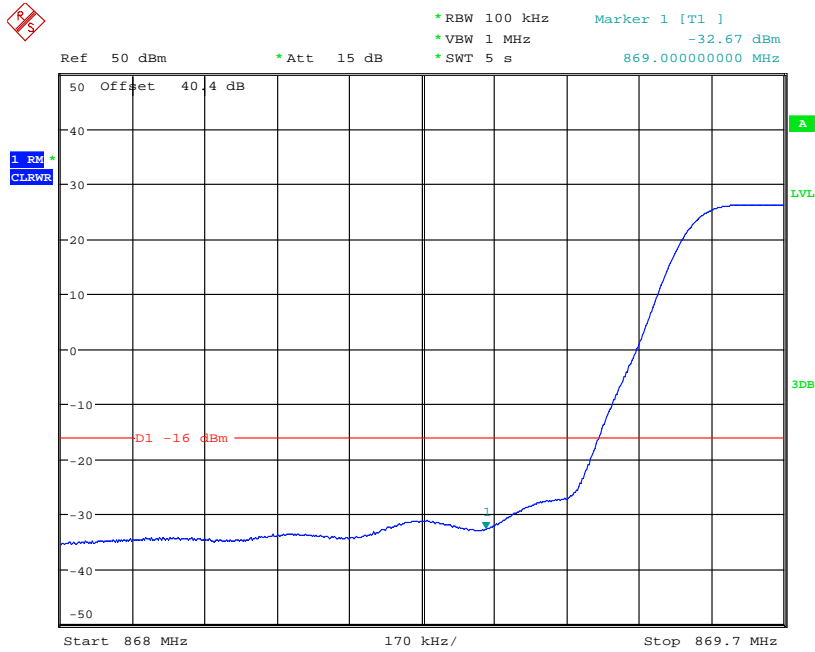

Date: 22.NOV.2011 12:27:08

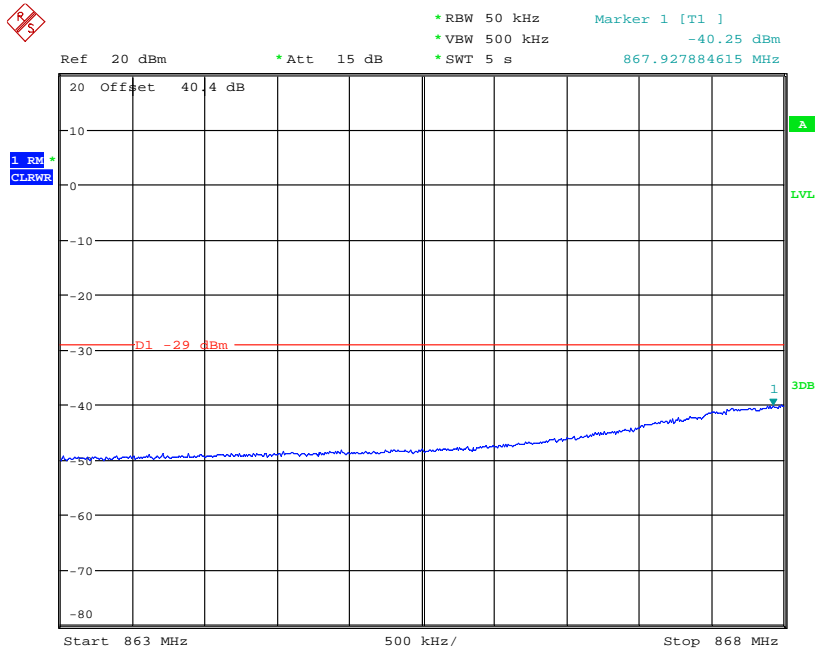

Date: 22.NOV.2011 12:01:24



Configuration 1 - Mode 3 - 10

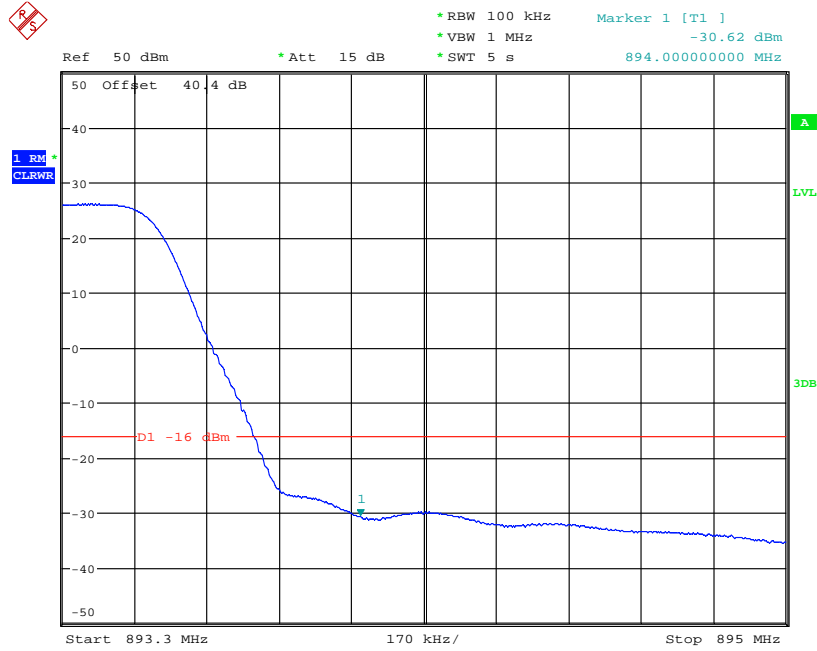

Date: 22.NOV.2011 11:57:53

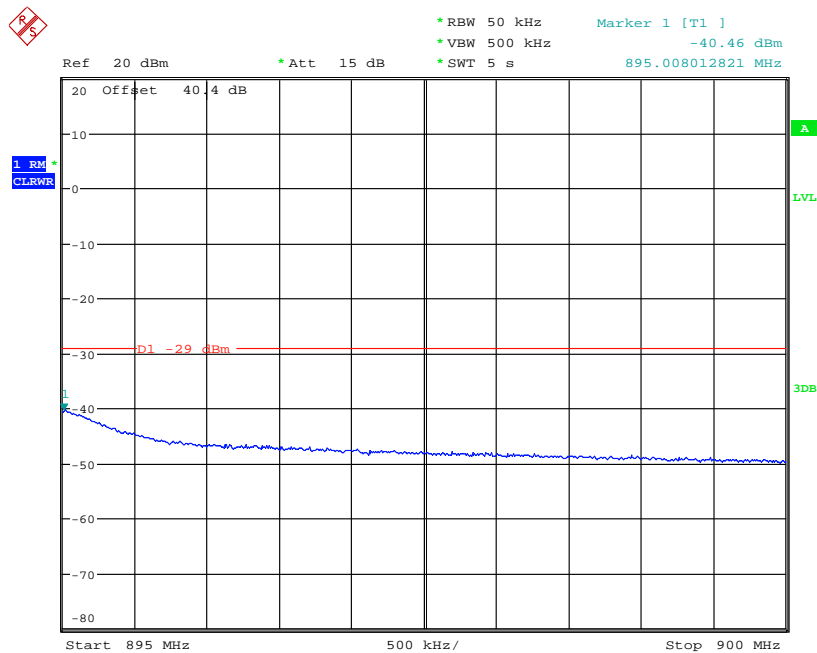

Date: 22.NOV.2011 11:59:19



15.0MHz Bandwidth

Configuration 1 - Mode 1 - 15

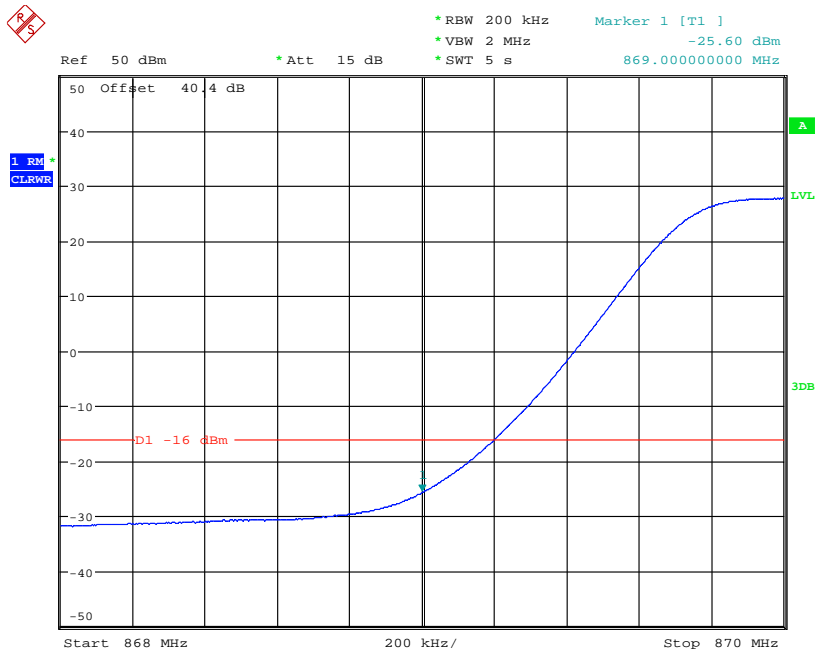

Date: 22.NOV.2011 12:11:15

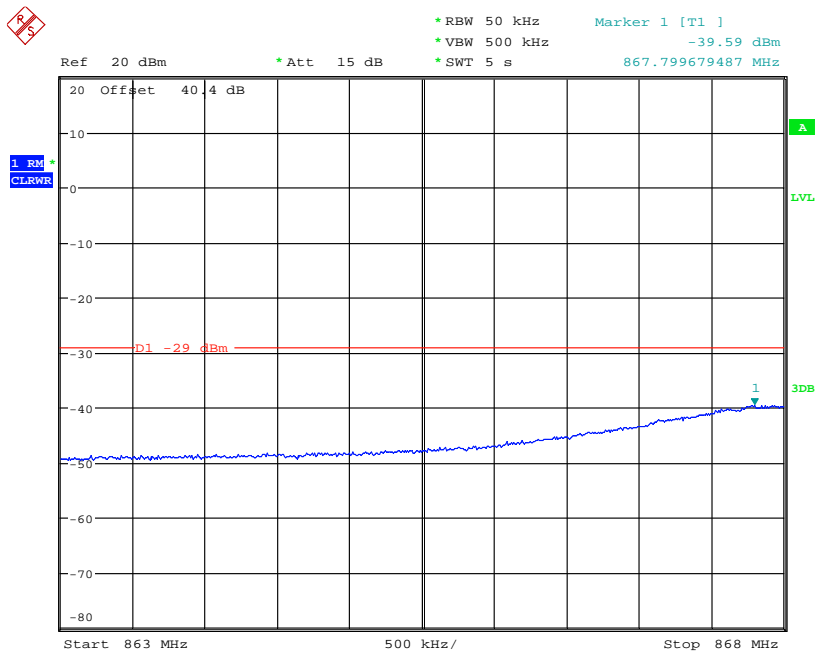

Date: 22.NOV.2011 12:13:57



Configuration 1 - Mode 3 - 15

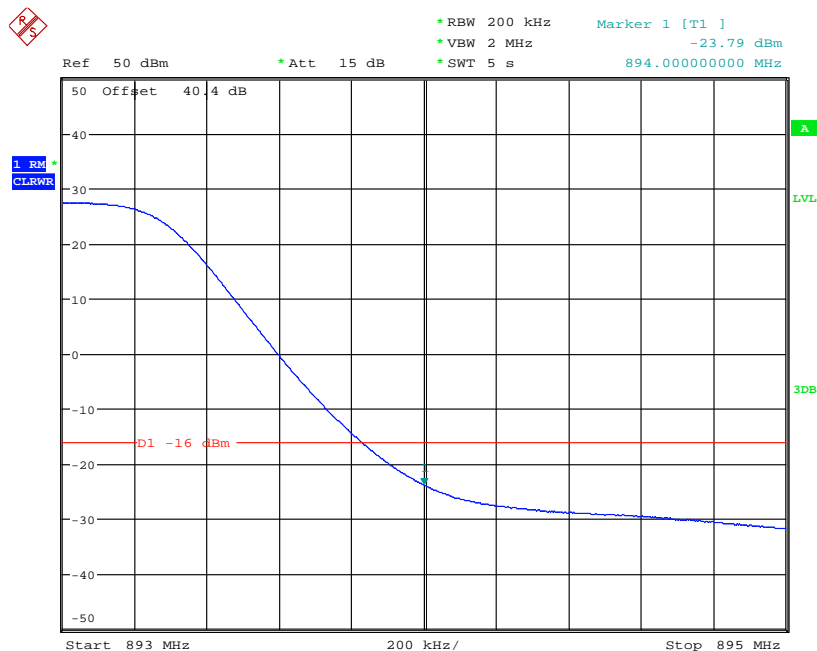

Date: 22.NOV.2011 12:21:15

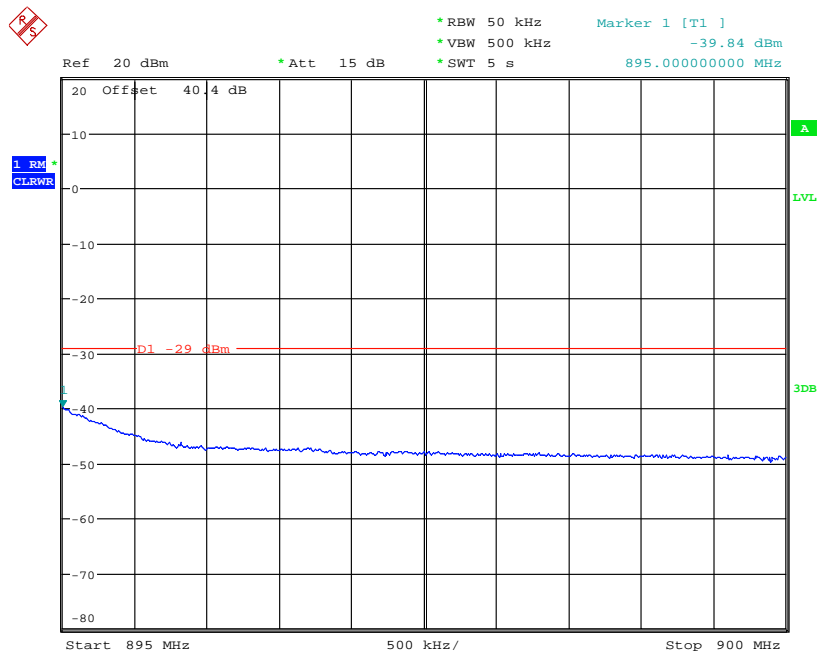

Date: 22.NOV.2011 12:19:35



20.0MHz Bandwidth

Configuration 1 - Mode 1 - 20

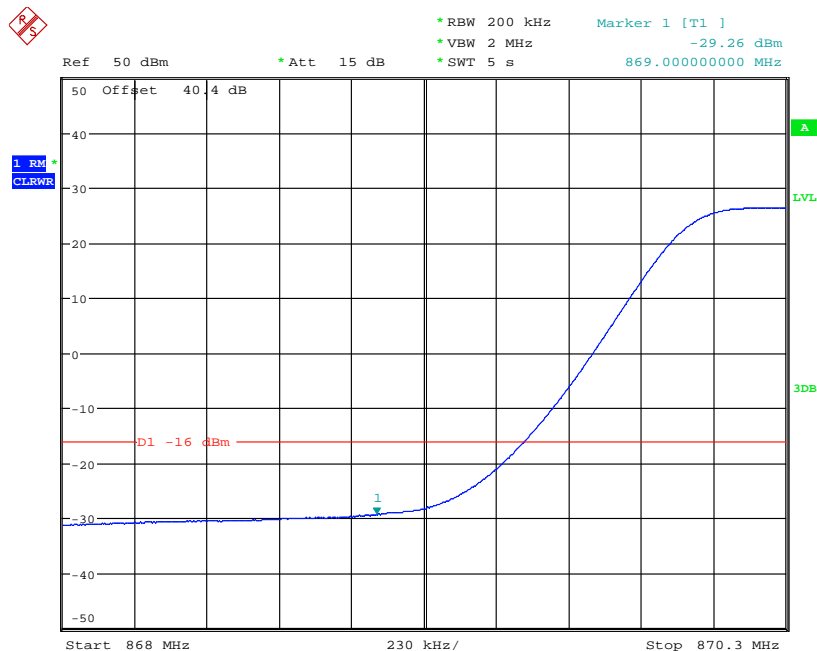

Date: 22.NOV.2011 11:41:54

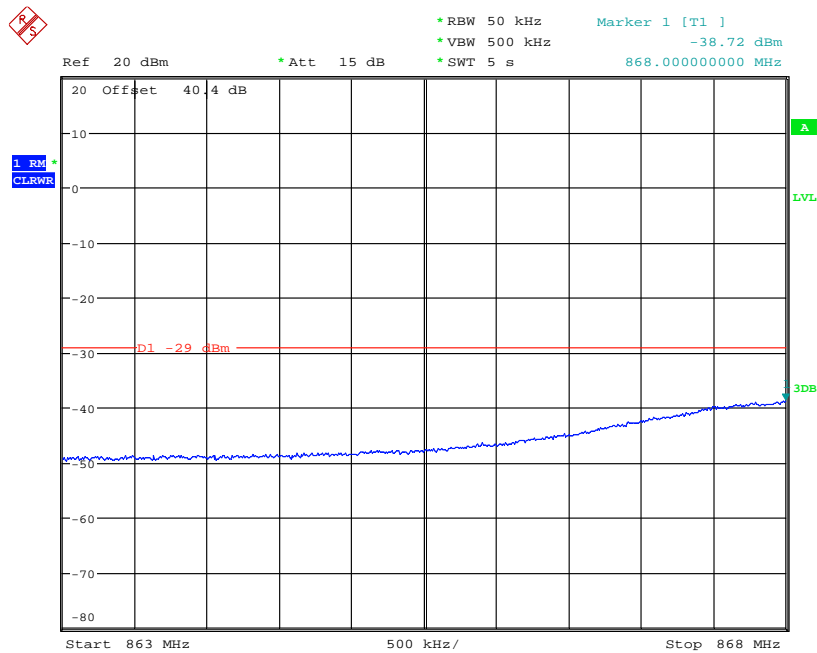

Date: 22.NOV.2011 11:44:14



Configuration 1 - Mode 3 - 20

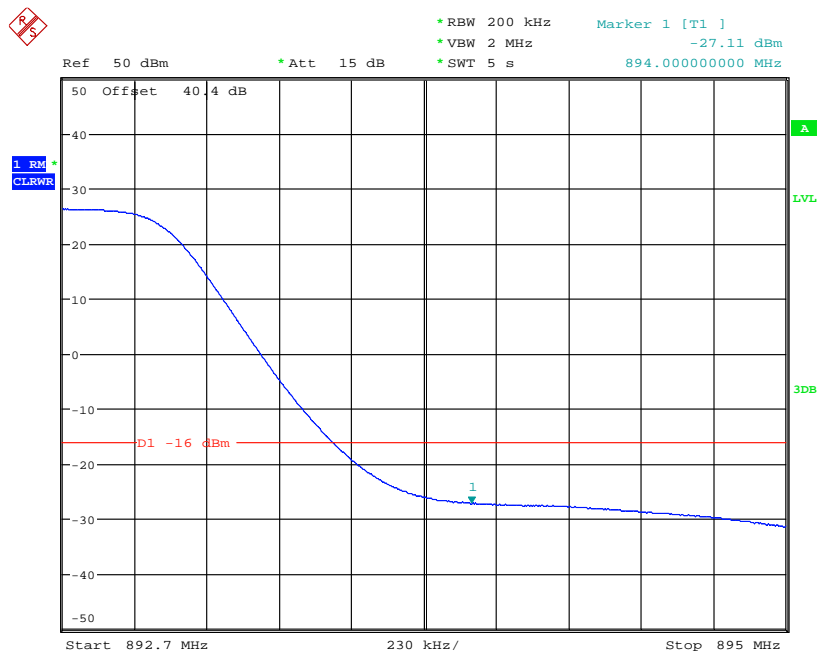

Date: 22.NOV.2011 11:52:07

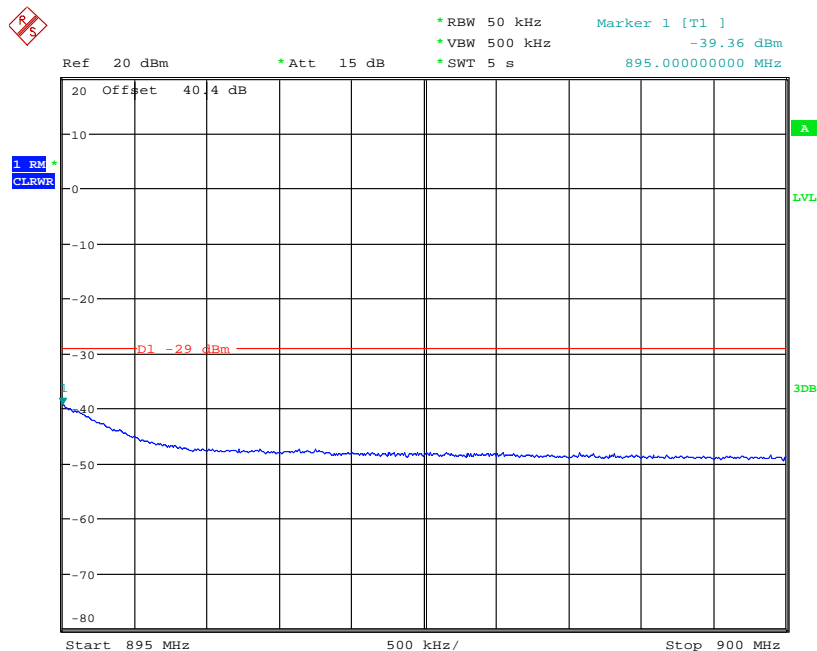

Date: 22.NOV.2011 11:49:55

Limit

The power of any emission outside the frequency band shall be attenuated below the transmitter power (P) by at least $43 + 10\log P$ dB.



Product Service

2.6 RADIATED SPURIOUS EMISSIONS

2.6.1 Specification Reference

FCC CFR 47 Part 2, Clause 2.1053
FCC CFR 47 Part 22, Clause 22.917 (a)
Industry Canada RSS-132, Clause 4.5

2.6.2 Equipment Under Test

RRUS 11 B5 / KRC 161 285/2, S/N: CB4L317562

2.6.3 Date of Test and Modification State

05 and 06 December 2011 – Modification State 0

2.6.4 Test Equipment Used

The major items of test equipment used for the above tests are identified in Section 3.1.

2.6.5 Test Method and Operating Modes

The test was applied in accordance with the test method requirements of FCC CFR 47 Part 2 and Part 22 and Industry Canada RSS-132.

A preliminary profile of the Spurious Radiated Emissions was obtained by operating the EUT on a remotely controlled turntable within the chamber. Measurements of emissions from the EUT were obtained with the Measurement Antenna in both Horizontal and Vertical Polarizations.

Emissions identified within the range 30MHz – 25GHz were then formally measured using a Peak detector as the worst case.

In the frequency Range 30MHz – 25GHz, the measurement was performed with a resolution bandwidth of 1MHz.

The measurements were performed at a 3m distance unless otherwise stated.

The limits for Spurious Emissions have been calculated, as shown below using the following formula:

Field Strength of Carrier - $(43 + 10\log(P))$ dB

Where:

Field Strength is measured in dB μ V/m

P is measured Transmitter Power in Watts



Determination of Spurious Emission Limit

As the EUT does not have an integral antenna, the field strength of the carrier has been calculated assuming that the power is to be fed to a half-wave tuned dipoles as per 2.1053 (a).

$$E_{(v/m)} = (30 \times G_i \times P_o)^{0.5} / d$$

Where G_i is the antenna gain of ideal half-wave dipoles,
 P_o is the power out of the transceiver in W,
 d is the measurement distance in meter.

Therefore at 3m measurement distance the field strength using the lowest transceiver output power would be:

$$E_{(v/m)} = (30 \times 1.64 \times 71.13)^{0.5} / 3 = 19.719V/m = 145.9dB\mu V/m$$

As per 22.917(a) the spurious emission must be attenuated by $43 + 10\log(P_o)$ dB this gives:

$$43 + 10\log(71.13) = 61.5dB$$

Therefore the limit at 3m measurement distance is:

$$145.9 - 61.5 = 84.4 \text{ dB}\mu V/m$$

This limit has been used to determine Pass or Fail for the harmonics measured and detailed in the following results.

The test was performed with the EUT in the following configurations and modes of operation:

Configuration 1 - Mode 1 - 1.4
 - Mode 2 (1.4MHz, 3MHz, 5MHz, 10MHz, 15MHz, 20.0MHz OBW)
 - Mode 3 - 1.4

2.6.6 Environmental Conditions

	05 December 2011	06 November 2011
Ambient Temperature	24.5°C	25.0°C
Relative Humidity	35.5%	32.5%



2.6.7 Test Results

For the period of test the EUT met the requirements of FCC CFR 47 Part 2 & Part 22 and Industry Canada RSS-132 for Radiated Spurious Emissions.

The test results are shown below

Note: Only the worst case results plots have been included as all of the emissions are greater than 20dB below the limit. A set of plots have been included to show the measurement system noise floor.

E-TM1.1: 1.4MHz Bandwidth

Configuration 1 - Mode 1 - 1.4

No emissions were detected within 20dB of the limit.

Configuration 1 - Mode 2

30MHz to 1GHz

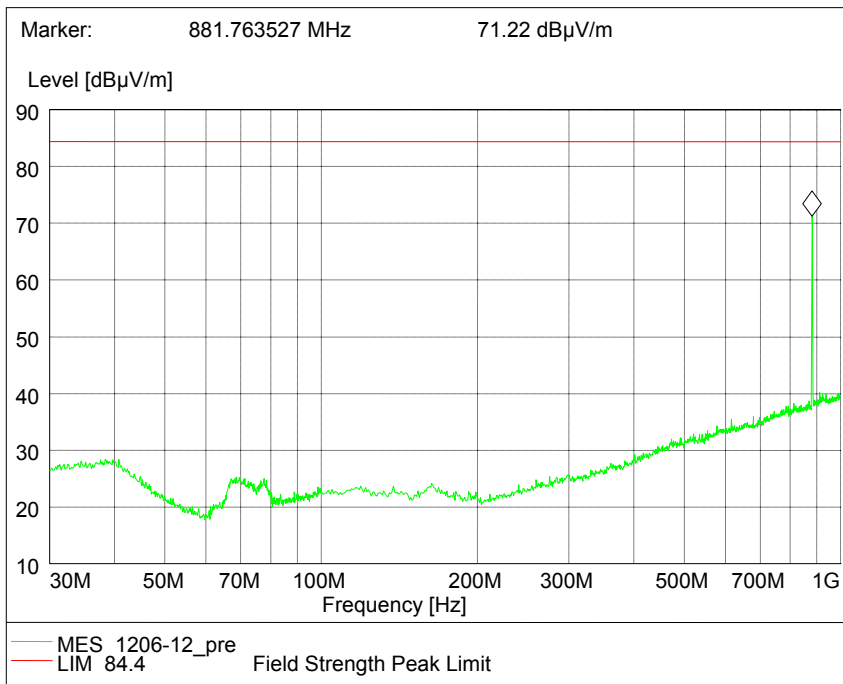

Note: The emission beyond the limit is the operating frequency.



1GHz to 18GHz

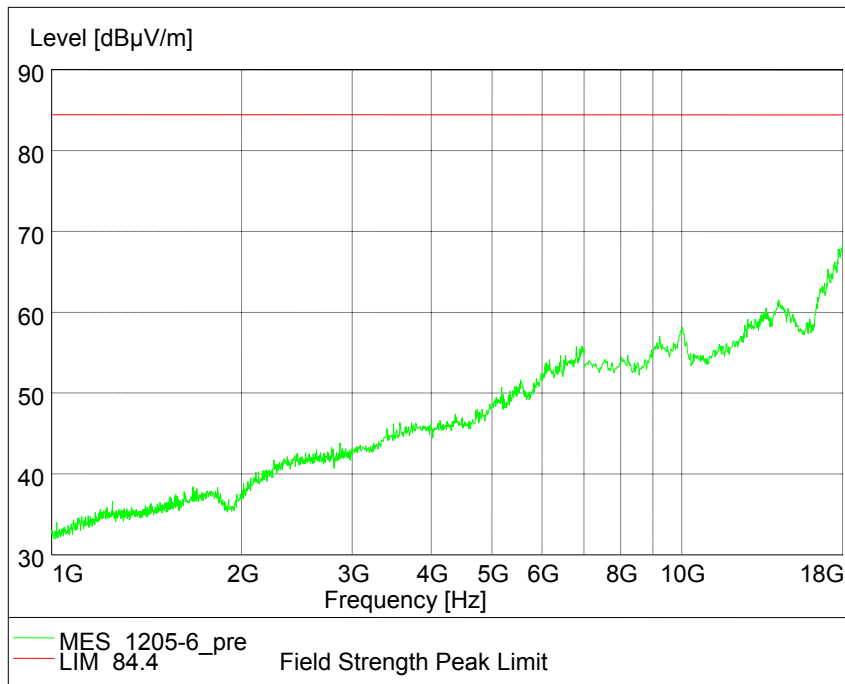

18GHz to 25GHz

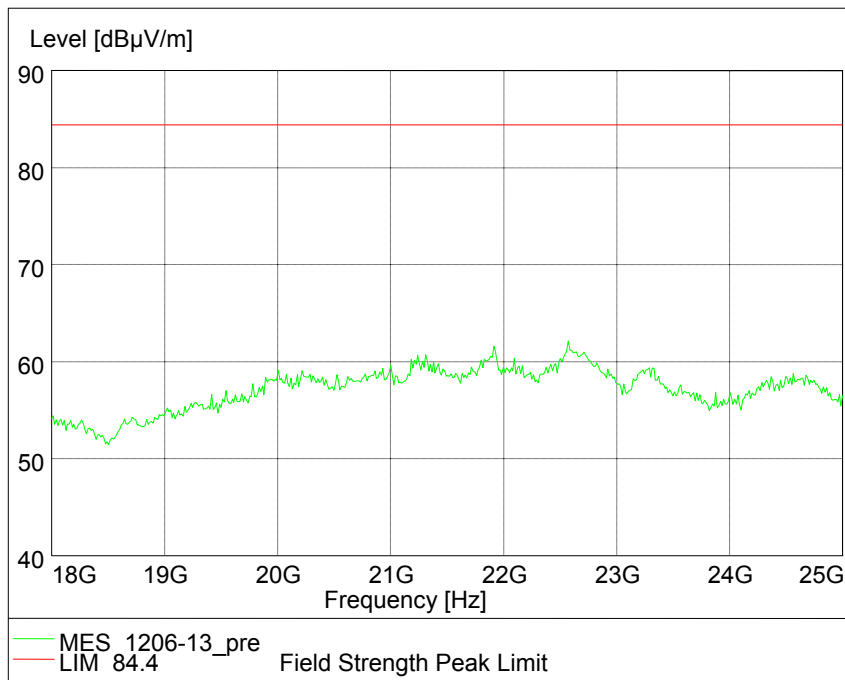



Product Service

Configuration 1 - Mode 3 - 1.4

No emissions were detected within 20dB of the limit.

E-TM 1.1: 3.0MHz, 5.0MHz, 10MHz, 15MHz, 20MHz Bandwidth

Configuration 1 - Mode 2

No emissions were detected within 20dB of the limit.

E-TM3.2: 1.4MHz Bandwidth

Configuration 1 - Mode 2

No emissions were detected within 20dB of the limit.

E-TM3.1: 1.4MHz Bandwidth

Configuration 1 - Mode - 2

No emissions were detected within 20dB of the limit.

Limit	-13dBm / 84.4dBµV/m
-------	---------------------

Remarks

The EUT does not exceed -13dBm / 84.4dBµV/m at the measured frequencies.



Product Service

2.7 CONDUCTED SPURIOUS EMISSIONS

2.7.1 Specification Reference

FCC CFR 47 Part 2, Clause 2.1051
FCC CFR 47 Part 22, Clause 22.917 (a)
Industry Canada RSS-132, Clause 4.5

2.7.2 Equipment Under Test

RRUS 11 B5 / KRC 161 285/2, S/N: CB4L317562

2.7.3 Date of Test and Modification State

23 and 24 November 2011 – Modification State 0

2.7.4 Test Equipment Used

The major items of test equipment used for the above tests are identified in Section 3.1.

2.7.5 Test Method and Operating Modes

The test was applied in accordance with the test method requirements of FCC CFR 47 Part 2 and Part 22 and Industry Canada RSS-132.

In accordance with Part 2.1051, the spurious emissions from the antenna terminal were measured. The transmitter output power was attenuated using an attenuator and the frequency spectrum investigated from 9kHz to 25GHz. The EUT was set to transmit on maximum power. The EUT was tested on Bottom, Middle and Top channels for E-TM1.1 test model in 1.4MHz and 20MHz bandwidth configurations as the representative modes. The resolution was set to 1MHz for 9kHz to 25GHz thus meeting the requirements of Industry Canada RSS-132 Clause 4.5.1.2. The spectrum analyzer detector was set to peak and trace was kept on Max Hold.

Since the EUT transmits on two antennas simultaneously in the same frequency range, i.e, TX Diversity, using the Measure and Add $10\log(N)$ dB technique, the limit for Conducted Spurious Emissions was adjusted with a correction of $10\log 2$ to -16dBm.

The maximum path loss across the measurement band was used as the reference level offset to ensure worst case.

In addition, measurements were made up to the 10th harmonic of the highest internal frequency.

The test was performed with the EUT in the following configurations and modes of operation:

Configuration 1 - Mode 1 - 1.4, Mode 1 - 20
- Mode 2 (1.4MHz, 20.0MHz OBW)
- Mode 3 - 1.4, Mode 3 - 20



2.7.6 Environmental Conditions

	23 November 2011	24 November 2011
Ambient Temperature	24.0°C	22.5°C
Relative Humidity	20.2%	20.3%

2.7.7 Test Results

For the period of test the EUT met the requirements of FCC CFR 47 Part 2 and Part 22 and Industry Canada RSS-132 for Conducted Spurious Emissions.

The test results are shown below

Remark:

The emissions at 9kHz on the plots was not generated by the test object. A complementary measruement with a smaller Span showed that it was related to the LO feedthrough.

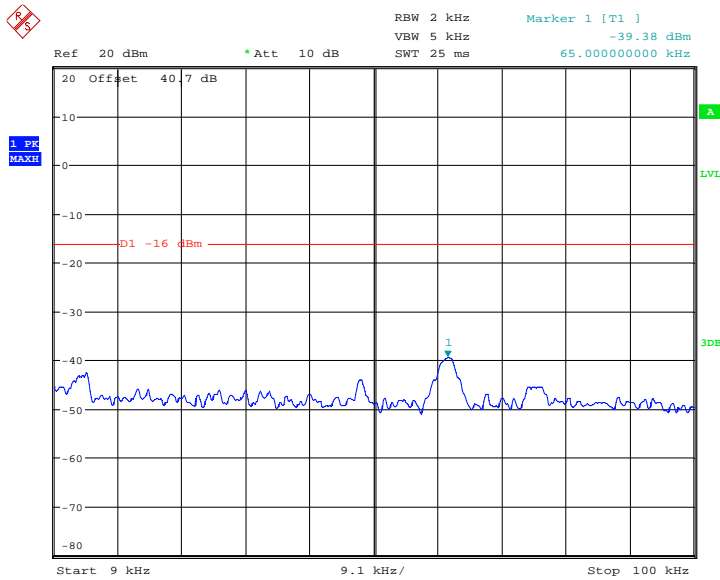

Date: 23.NOV.2011 08:40:31



Product Service

Antenna A

E-TM1.1

1.4MHz Bandwidth

Configuration 1 - Mode 1 - 1.4

9kHz to 1.45GHz

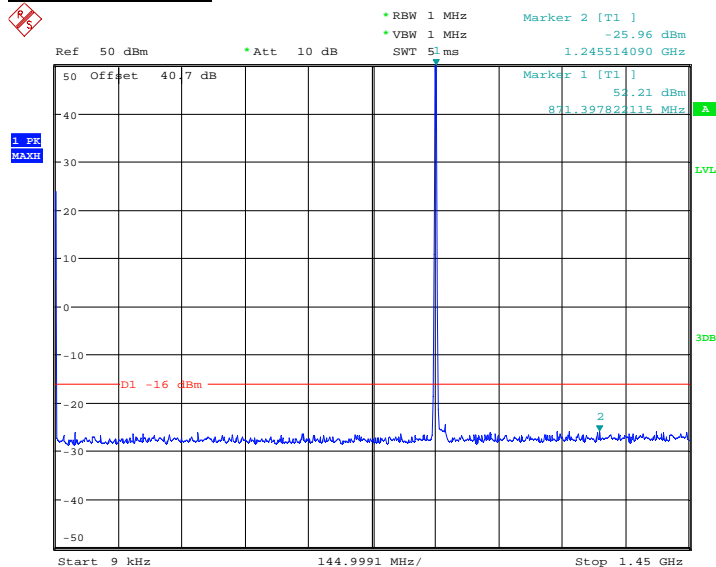

Date: 24.NOV.2011 09:18:46

Note: The emission beyond the limit is the operating frequency.

1.45GHz to 25GHz

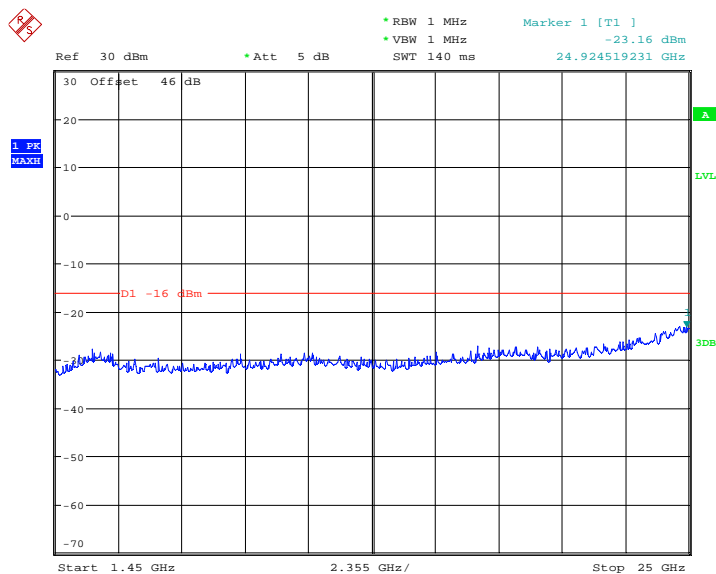

Date: 24.NOV.2011 08:13:46



Configuration 1 - Mode 2

9kHz to 1.45GHz

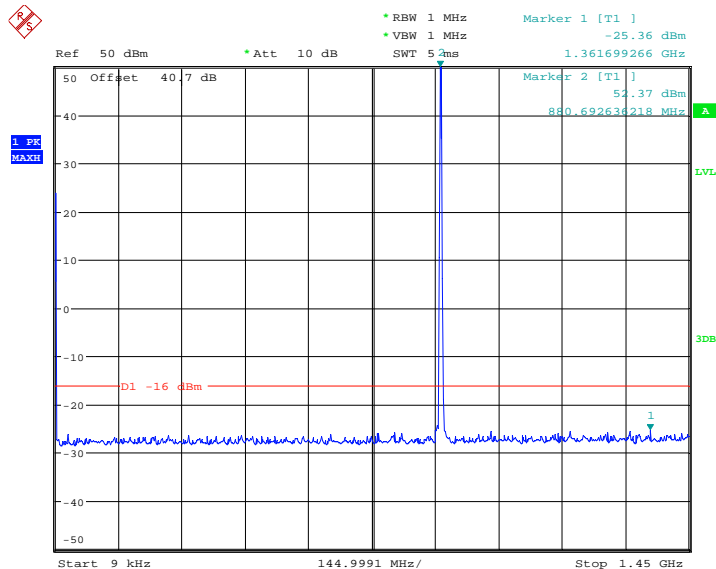

Date: 24.NOV.2011 09:12:54

Note: The emission beyond the limit is the operating frequency.

1.45GHz to 25GHz

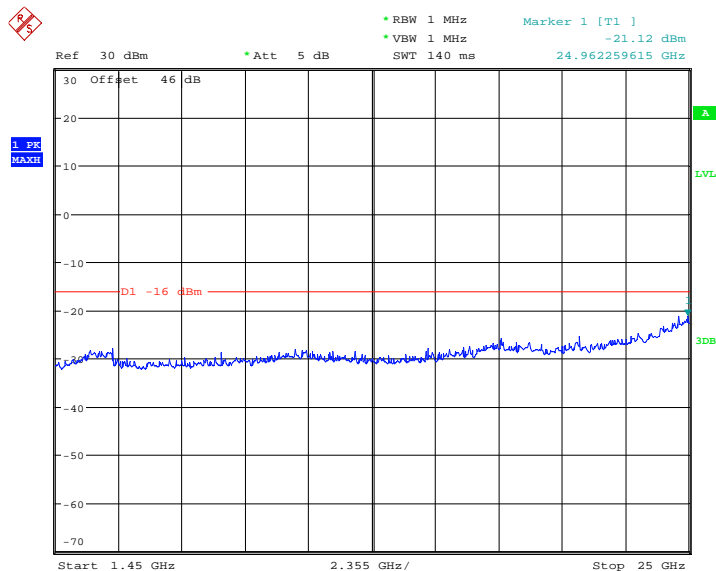

Date: 24.NOV.2011 08:06:11



Product Service

Configuration 1 - Mode 3 - 1.4

9kHz to 1.45GHz

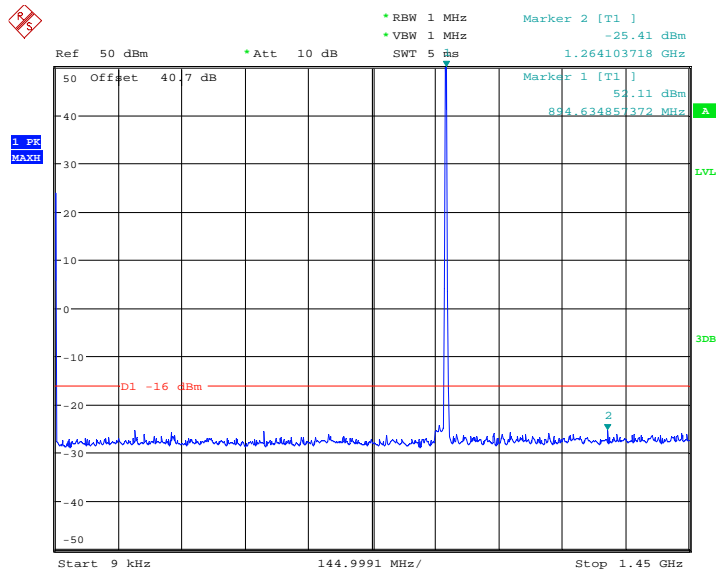

Date: 24.NOV.2011 09:20:33

Note: The emission beyond the limit is the operating frequency.

1.45GHz to 25GHz

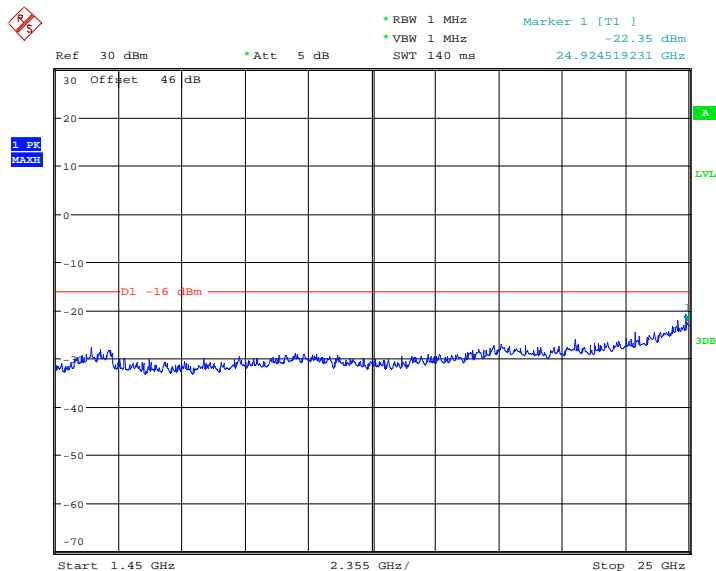

Date: 24.NOV.2011 08:15:05



Product Service

20MHz Bandwidth

Configuration 1 - Mode 1 - 20

9kHz to 1.45GHz

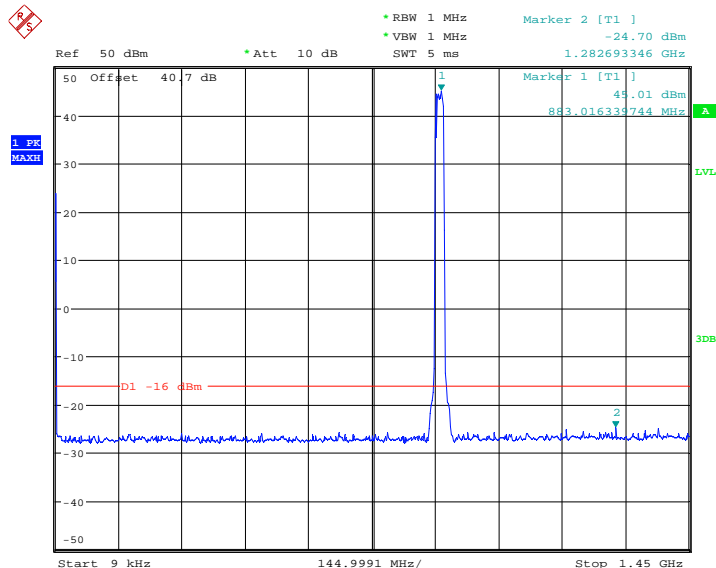

Date: 24.NOV.2011 08:39:32

Note: The emission beyond the limit is the operating frequency.

1.45GHz to 25GHz

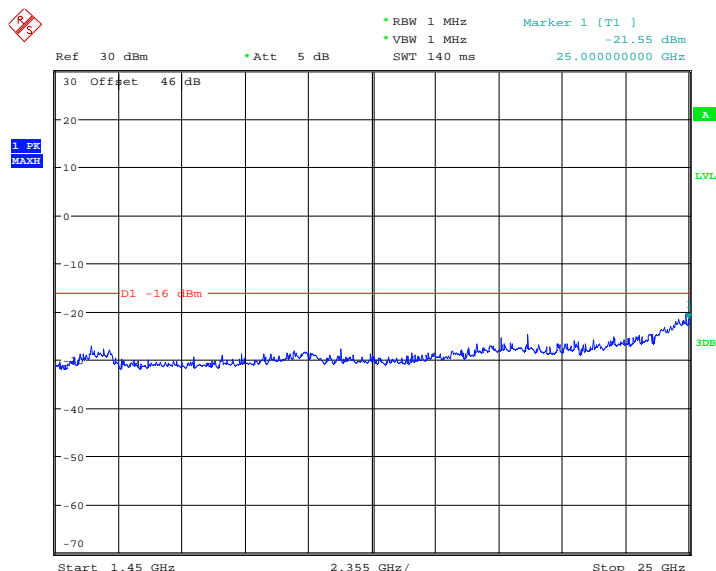

Date: 24.NOV.2011 08:21:35



Product Service

Configuration 1 - Mode 2

9kHz to 1.45GHz

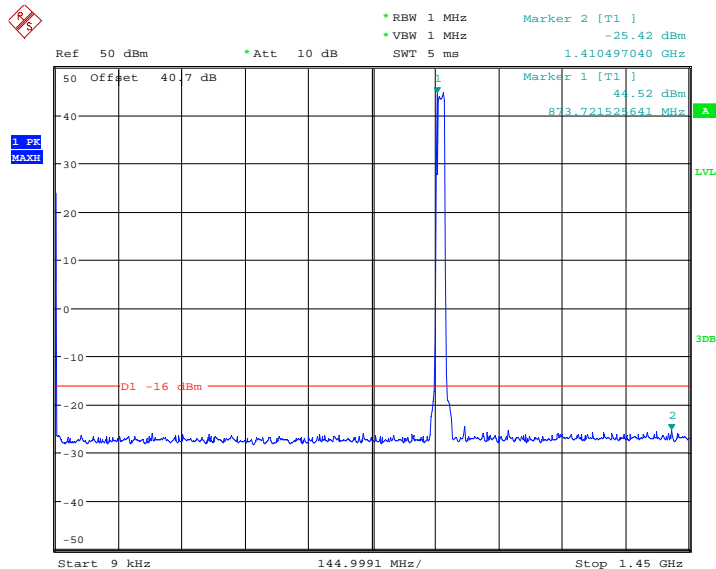

Date: 24.NOV.2011 08:33:18

Note: The emission beyond the limit is the operating frequency.

1.45GHz to 25GHz

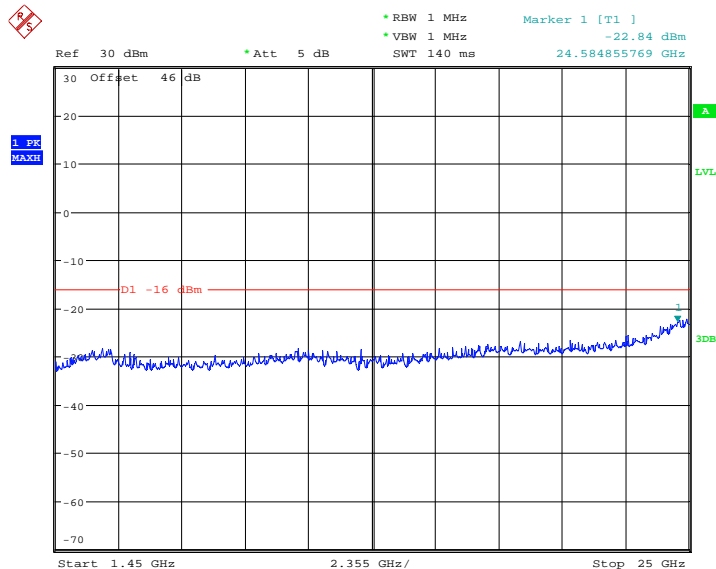

Date: 24.NOV.2011 08:25:33



Product Service

Configuration 1 - Mode 3 - 20

9kHz to 1.45GHz

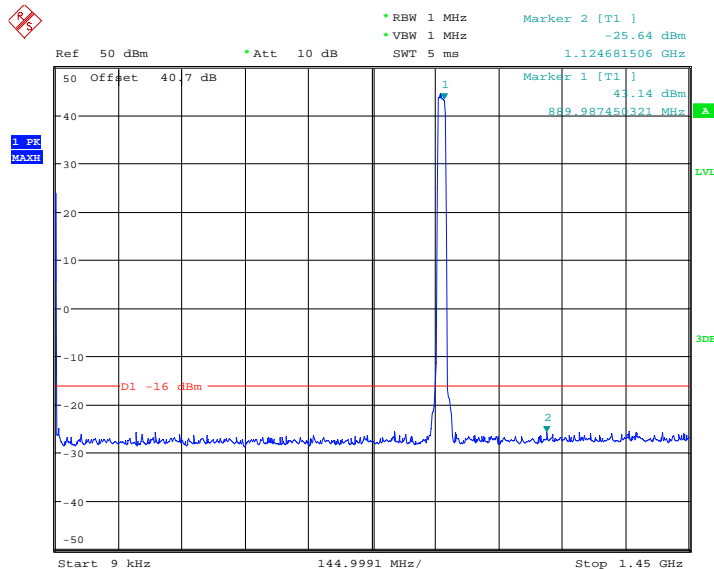

Date: 24.NOV.2011 08:42:21

Note: The emission beyond the limit is the operating frequency.

1.45GHz to 25GHz

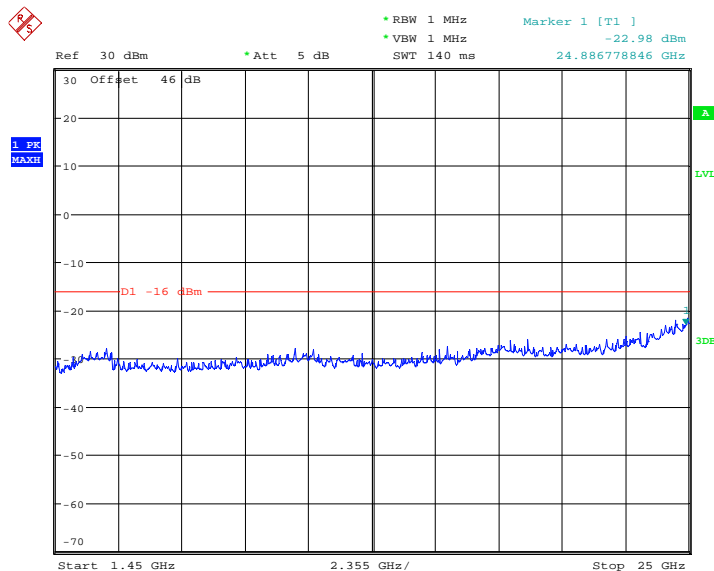

Date: 24.NOV.2011 08:23:20



Product Service

Antenna B

E-TM1.1

1.4MHz Bandwidth

Configuration 1 - Mode 1 - 1.4

9kHz to 1.45GHz

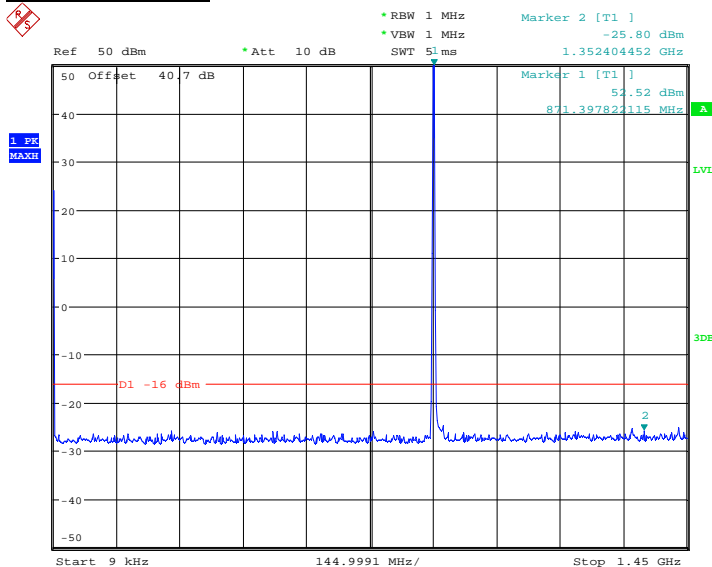

Date: 23.NOV.2011 15:17:13

Note: The emission beyond the limit is the operating frequency.

1.45GHz to 25GHz

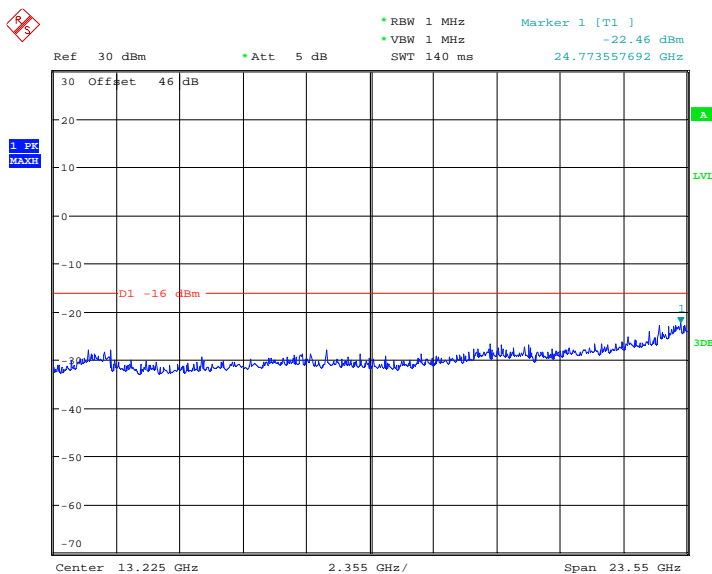

Date: 23.NOV.2011 16:15:26



Configuration 1 - Mode 2

9kHz to 1.45GHz

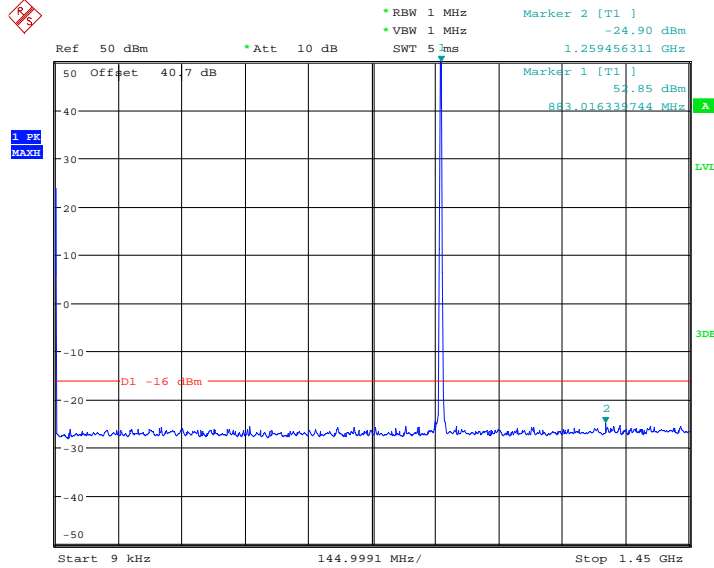

Date: 23.NOV.2011 15:13:25

Note: The emission beyond the limit is the operating frequency.

1.45GHz to 25GHz

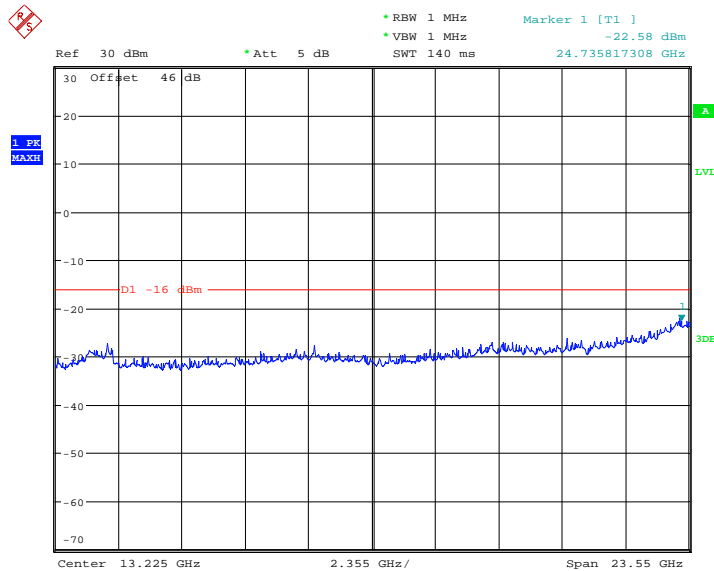

Date: 23.NOV.2011 16:12:32



Configuration 1 - Mode 3 - 1.4

9kHz to 1.45GHz

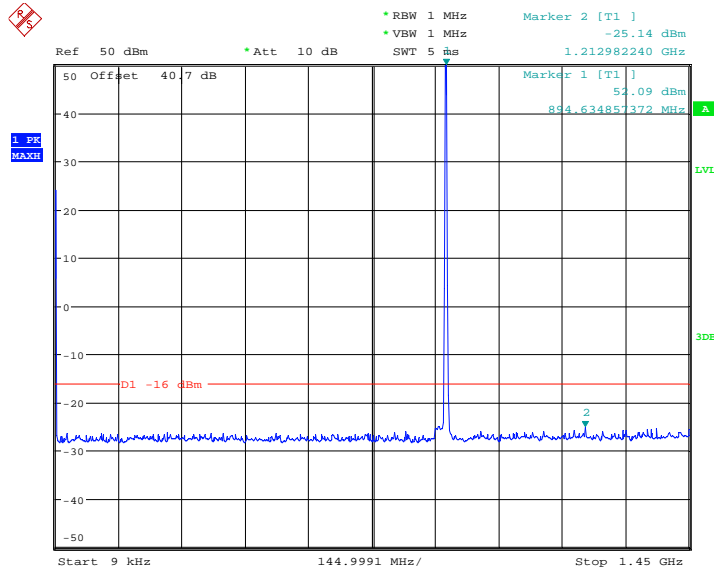

Date: 23.NOV.2011 15:20:04

Note: The emission beyond the limit is the operating frequency.

1.45GHz to 25GHz

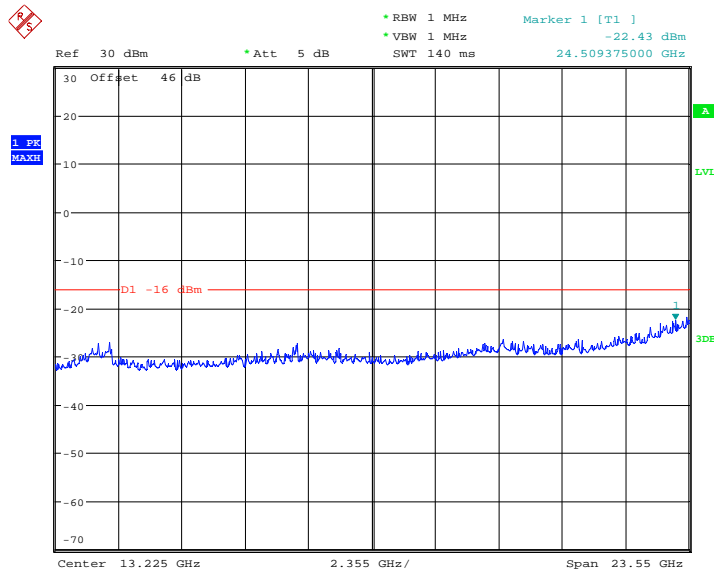

Date: 23.NOV.2011 16:16:41



Product Service

20MHz Bandwidth

Configuration 1 - Mode 1 - 20

9kHz to 1.45GHz

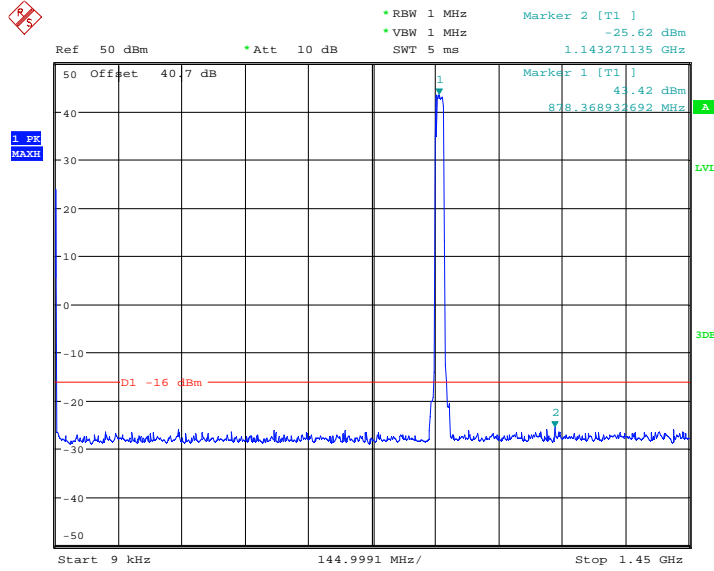

Date: 23.NOV.2011 15:44:28

Note: The emission beyond the limit is the operating frequency.

1.45GHz to 25GHz

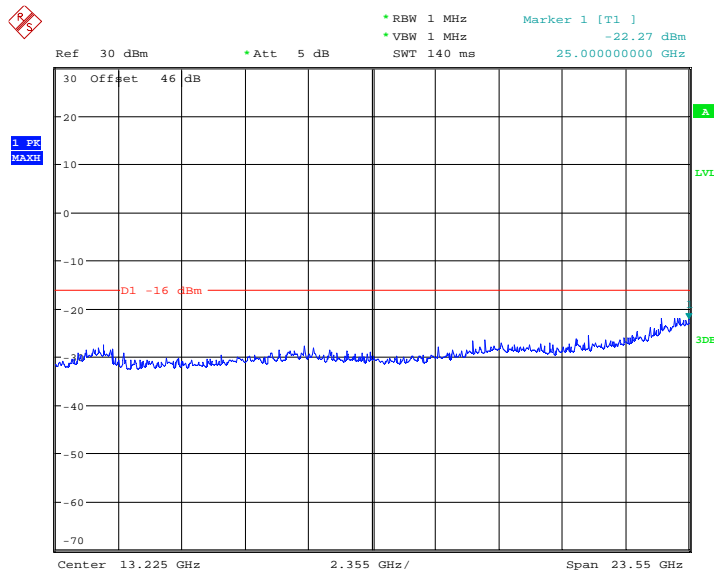

Date: 23.NOV.2011 16:10:26



Product Service

Configuration 1 - Mode 2

9kHz to 1.45GHz

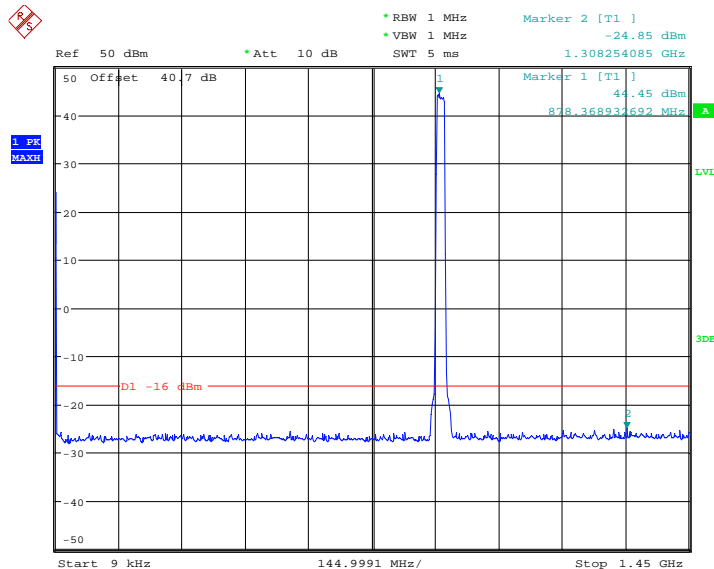

Date: 23.NOV.2011 15:50:55

Note: The emission beyond the limit is the operating frequency.

1.45GHz to 25GHz

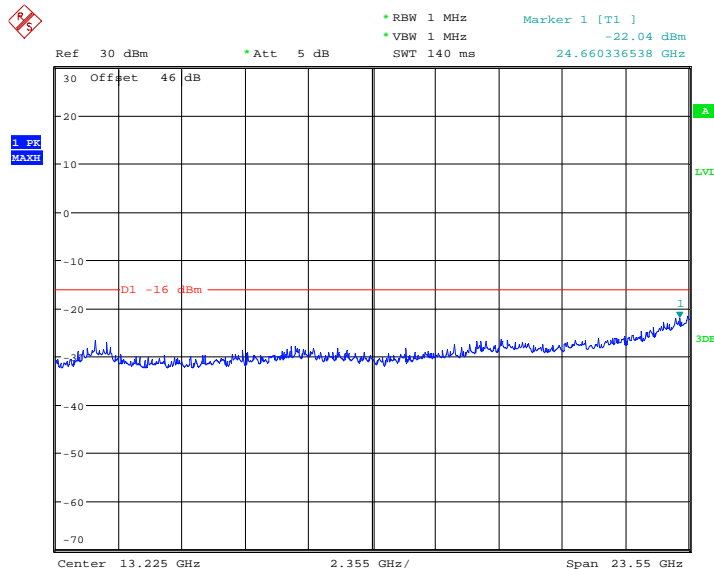

Date: 23.NOV.2011 16:03:23



Product Service

Configuration 1 - Mode 3 - 20

9kHz to 1.45GHz

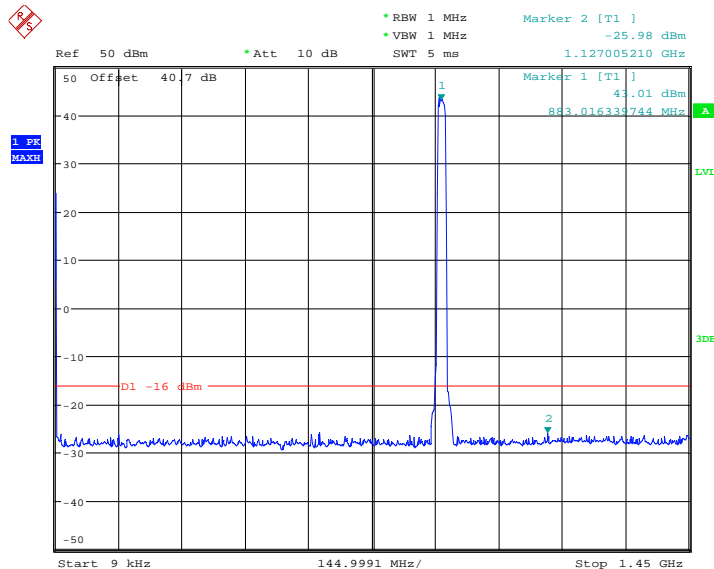

Date: 23.NOV.2011 15:55:43

Note: The emission beyond the limit is the operating frequency.

1.45GHz to 25GHz

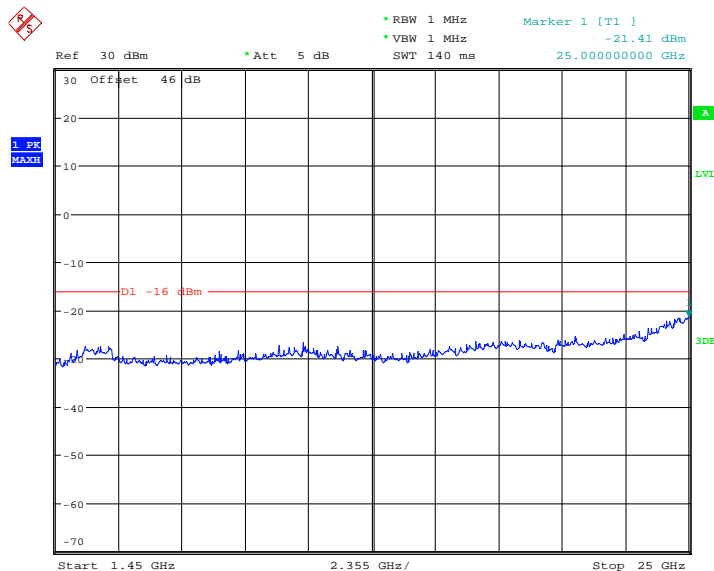

Date: 23.NOV.2011 16:02:47

Remarks

The EUT does not exceed -16dBm (-13dBm – 10log2) at the frequency range of 9kHz to 25GHz.



Product Service

2.8 FREQUENCY STABILITY UNDER TEMPERATURE VARIATIONS

2.8.1 Specification Reference

FCC CFR 47 Part 2, Clause 2.1055
 FCC CFR 47 Part 22, Clause 22.355
 Industry Canada RSS-132, Clause 4.3

2.8.2 Equipment Under Test

RRUS 11 B5 / KRC 161 285/2, S/N: CB4L317562

2.8.3 Date of Test and Modification State

28 and 29 November 2011 – Modification State 0

2.8.4 Test Equipment Used

The major items of test equipment used for the above tests are identified in Section 3.1.

2.8.5 Test Method and Operating Modes

The test was applied in accordance with the test method requirements of FCC CFR 47 Part 2 and Part 22 and Industry Canada RSS-132.

The EUT was set to transmit on maximum power. A Spectrum Analyzer was used to measure the frequency error. The temperature was adjusted between -30°C and +50°C in 10° steps as per 2.1055.

The EUT was tested with test model E-TM1.1 in 5MHz Bandwidth.

The test was performed with the EUT in the following configurations and modes of operation:

Configuration 1 - Mode 2 (5.0MHz OBW)

2.8.6 Environmental Conditions

	28 November 2011	29 November 2011
Ambient Temperature	25.0°C	22.7°C
Relative Humidity	20.3%	22.0%



Product Service

2.8.7 Test Results

For the period of test the EUT met the requirements of FCC CFR 47 Part 2 and Part 22 and Industry Canada RSS-132 for Frequency Stability Under Temperature Variations.

The test results are shown below

Power Supply: -48V DC

E-TM1.1: 5MHz Bandwidth

Configuration 1 - Mode 2

Temperature Interval (°C)	Deviation (Hz)
-30	-4.60
-20	4.51
-10	-4.76
0	-4.53
+10	8.08
+20	7.54
+30	8.03
+40	7.09
+50	7.58

Limit	±1.5 ppm or ±1.322 kHz
-------	------------------------

Remarks

The frequency stability of the EUT is sufficient to keep it within the authorised frequency ranges at any temperature interval across the measured range.



Product Service

2.9 FREQUENCY STABILITY UNDER VOLTAGE VARIATIONS

2.9.1 Specification Reference

FCC CFR 47 Part 2, Clause 2.1055
FCC CFR 47 Part 22, Clause 22.355
Industry Canada RSS-132, Clause 4.3

2.9.2 Equipment Under Test

RRUS 11 B5 / KRC 161 285/2, S/N: CB4L317562

2.9.3 Date of Test and Modification State

29 November 2011 – Modification State 0

2.9.4 Test Equipment Used

The major items of test equipment used for the above tests are identified in Section 3.1.

2.9.5 Test Method and Operating Modes

The test was applied in accordance with the test method requirements of FCC CFR 47 Part 2 and Part 22 and Industry Canada RSS-132.

The EUT was set to transmit on maximum power. A Spectrum Analyzer was used to measure the frequency error. The supplied voltage was varied from 85 to 115 percent of the nominal value.

The EUT was tested with test model E-TM1.1 in 5MHz Bandwidth.

The test was performed with the EUT in the following configurations and modes of operation:

Configuration 1 - Mode 2 (5.0MHz)

2.9.6 Environmental Conditions

29 November 2011

Ambient Temperature 22.7°C

Relative Humidity 22.0%



Product Service

2.9.7 Test Results

For the period of test the EUT met the requirements of FCC CFR 47 Part 2 and Part 22 and Industry Canada RSS-132 for Frequency Stability Under Voltage Variations.

The test results are shown below

Temperature: 20°C

E-TM1.1: 5MHz Bandwidth

Configuration 1 - Mode 2

DC Voltage (V)	Deviation (Hz)
-40.8	6.78
-48.0	8.08
-55.2	8.04

Limit	±1.5 ppm or ±1.322 kHz
-------	------------------------

Remarks

The frequency stability of the EUT is sufficient to keep it within the authorised frequency ranges under voltage variations across the measured range.



Product Service

2.10 RECEIVER SPURIOUS EMISSIONS

2.10.1 Specification Reference

Clause 4.6 FCC CFR 47 Part 15, Clause 15.111
Industry Canada RSS-132

2.10.2 Equipment Under Test

RRUS 11 B5 / KRC 161 285/2, S/N: CB4L317562

2.10.3 Date of Test and Modification State

22 December 2011 – Modification State 0

2.10.4 Test Equipment Used

The major items of test equipment used for the above tests are identified in Section 3.1.

2.10.5 Test Method and Operating Modes

The test was applied in accordance with the test method requirements of FCC CFR 47 Part 15 and Industry Canada RSS-132.

In accordance with RSS-Gen Clause 6.2, the receiver spurious emissions from the antenna terminal were measured. Measurements were performed on the receiver antenna connector RF B. The EUT was set to transmitter mode on the TX connector RF A and during the measurement the RF A was terminated with match load, (50 Ohm).

The resolution was set to 120kHz in the frequency range 9kHz to 1GHz and 1MHz in the frequency range 1GHz to 13GHz thus meeting the requirements of RSS-Gen Clause 4.10. The spectrum analyzer detector was set to peak and trace was kept on Max Hold to give the worst case. The limit line was displayed, showing the -57dBm, 2 nanowatts in band 9kHz to 13GHz.

The maximum path loss across the measurement band was used as the reference level offset to ensure worst case.

In addition, measurements were made from 9kHz up to the 5th harmonic of the highest internal frequency.

The EUT was tested with test model E-TM1.1 in 1.4MHz Bandwidth.

The test was performed with the EUT in the following configurations and modes of operation:

- Configuration 1 - Mode 1 - 1.4
- Mode 2 (1.4MHz OBW)
- Mode 3 - 1.4



Product Service

2.10.6 Environmental Conditions

22 December 2011

Ambient Temperature 22.0°C

Relative Humidity 20.3%

2.10.7 Test Results

For the period of test the EUT met the requirements of FCC CFR 47 Part 15 and Industry Canada RSS-132 for Receiver Spurious Emissions.

The test results are shown below

Remark:

The emissions at 9kHz on the plots was not generated by the test object. A complementary measruement with a smaller Span showed that it was related to the LO feedthrough.

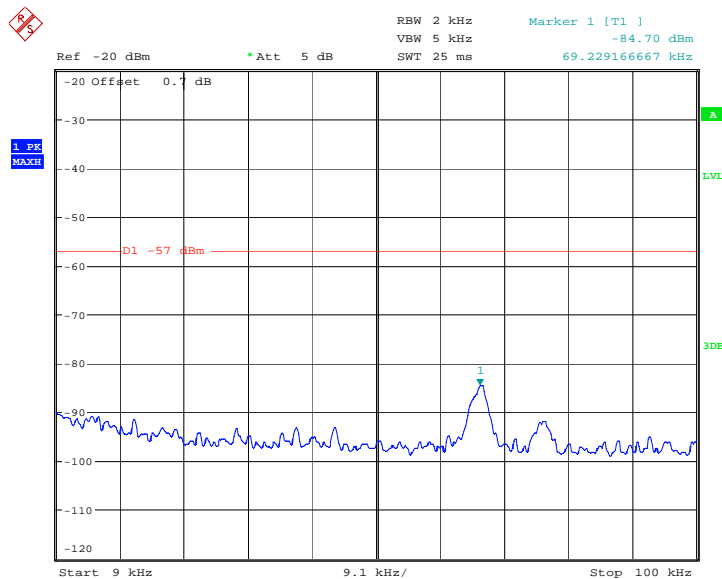

Date: 22.DEC.2011 09:49:08



E-TM1.1

1.4MHz Bandwidth

Configuration 1 - Mode 1 - 1.4

9kHz to 1GHz

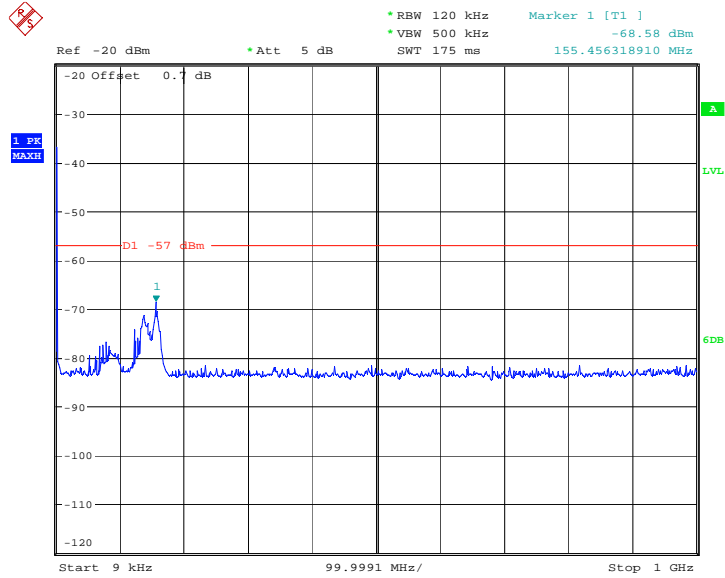

Date: 22.DEC.2011 09:35:37

1GHz to 13GHz

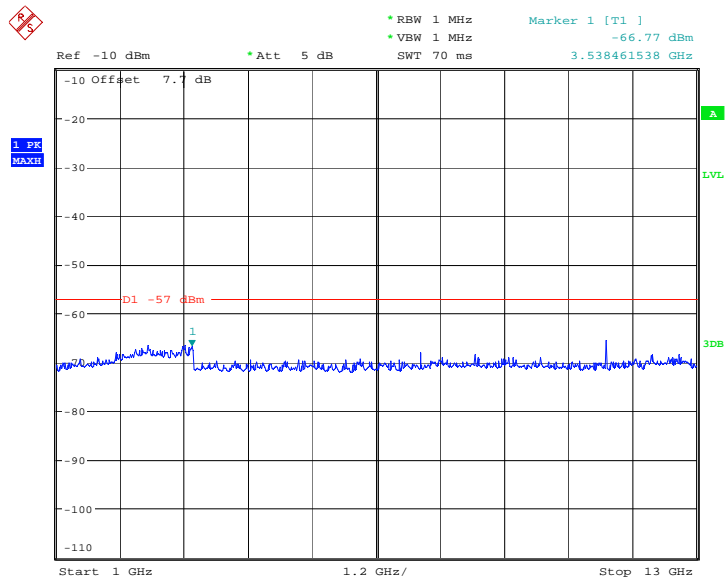

Date: 22.DEC.2011 09:36:53



Configuration 1 - Mode 2

9kHz to 1GHz

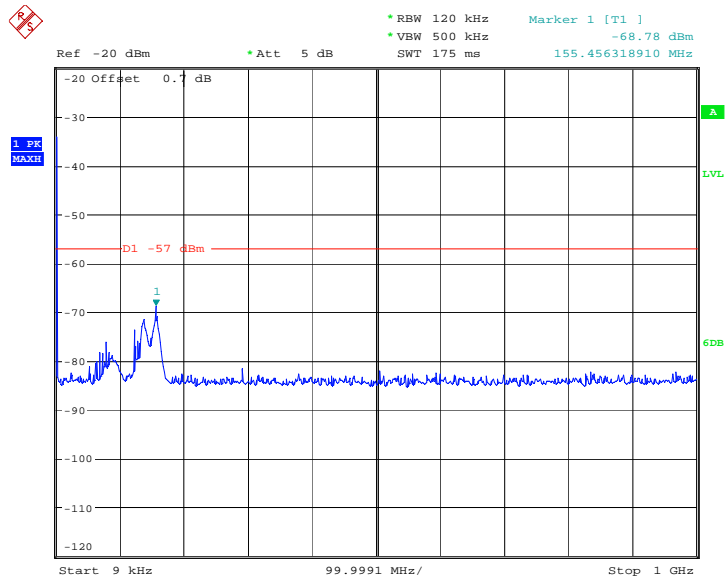

Date: 22.DEC.2011 09:42:18

1GHz to 13GHz

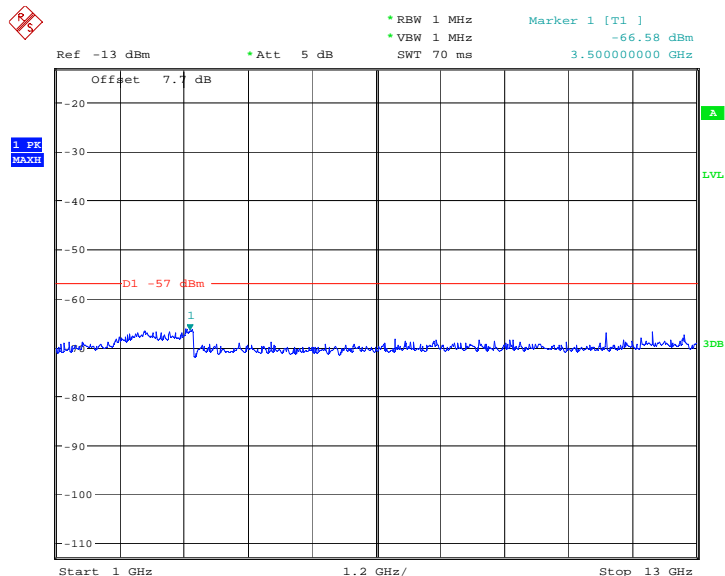

Date: 22.DEC.2011 09:43:44



Configuration 1 - Mode 3 - 1.4

9kHz to 1GHz

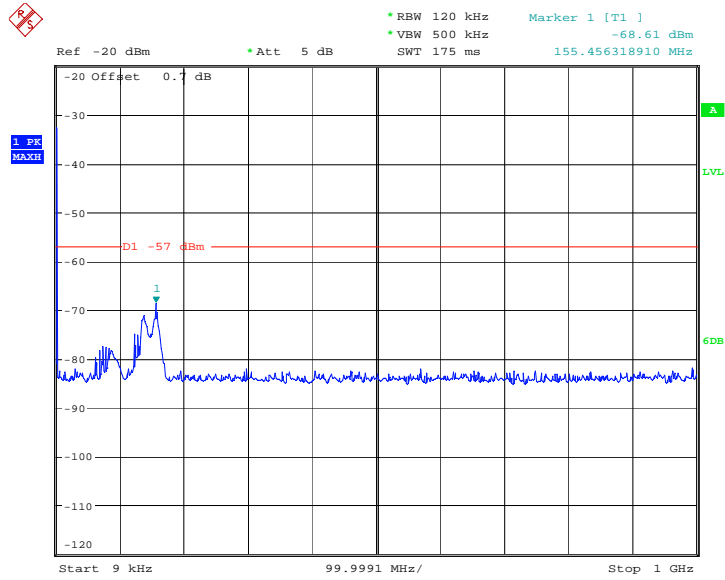

Date: 22.DEC.2011 09:48:36

1GHz to 13GHz

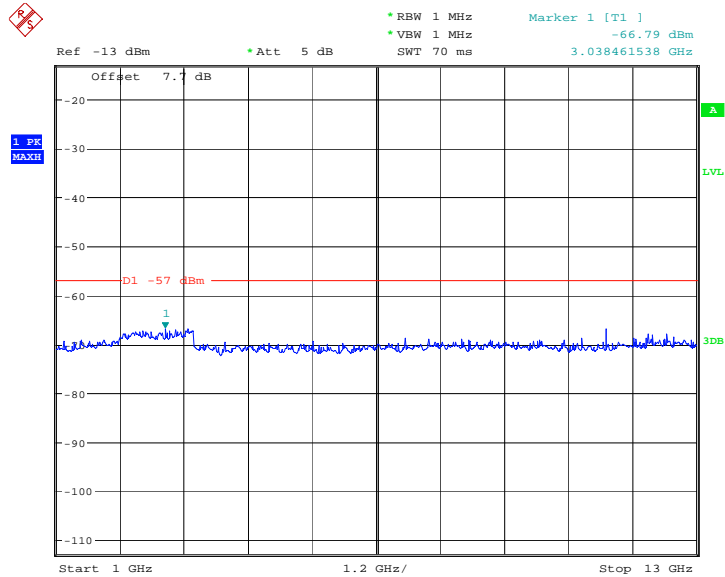

Date: 22.DEC.2011 09:47:30



Product Service

Limit

From 47 CFR Part 15.111:

The power at the antenna terminal at any frequency with the range of measurements shall not exceed -57dBm / 2 nanowatts.

From RSS GEN Section 6.2:

Receiver spurious emissions shall not exceed -57dBm / 2 nanowatts in the band 30MHz to 1000MHz, and -53dBm / 5 nanowatts above 1000MHz;

Remarks

The EUT does not exceed -57dBm at the frequency range of 9kHz to 13GHz.



Product Service

SECTION 3

TEST EQUIPMENT USED



3.1 TEST EQUIPMENT USED

List of absolute measuring and other principal items of test equipment.

Instrument	Manufacturer	Type No.	Serial No.	Calibration Period (months)	Calibration Due
Section 2.1, 2.2, 2.3, 2.4, 2.5, 2.7 and 2.10 – Maximum Conducted Output Power, Peak – Average Ratio, Modulation Characteristics, Occupied Bandwidth, Spurious Emissions at Antenna Terminals (± 1MHz) , Conducted Spurious Emissions and Receiver Spurious Emissions.					
Spectrum Analyzer	Rohde & Schwarz	FSQ26	100253	12	27-Mar-2012
Power Meter	Rohde & Schwarz	NRP	102438	12	10-Aug-2012
Thermal Power Sensor	Rohde & Schwarz	NRP-Z51	102431	12	10-Aug-2012
Network Analyzer	Agilent	8720D	US36140166	12	09-Sep-2012
40dB Attenuator	Aeroflex / Weinschel	48-40-43-LIM	BR5020	-	O/P MON
High-pass Filter	K&L	11SH10-1450	8	-	O/P MON
Load	Shanghai Huaxiang	TF100	09121614	-	O/P MON
Power Supply	Dahua	DH1716-5D	2007060047	-	O/P MON
Power Supply	Dahua	DH1716A-14	20080401	-	O/P MON
Digital Multi-meter	FLUKE	179	91820401	12	03-Jan-2012
Thermo-hygrometer	AZ Instruments	8705	9151655	12	16-Dec-2012
Section 2.6 – Radiated Spurious Emissions					
Load	Shanghai Huaxiang	TF150-3	06081410	-	O/P MON
Load	Shanghai Huaxiang	TF100	09121614	-	O/P MON
EMI Receiver	Rohde & Schwarz	ESI 40	100015	12	19-Aug-2012
Ultra log test antenna	Rohde & Schwarz	HL562	100167	12	19-Aug-2012
Double-Ridged Wave-guide Horn Antenna	Rohde & Schwarz	HF 906	100029	12	19-Aug-2012
Pyramidal Horn Antenna	EMCO	3160-09	-	-	-
Antenna master	Frankonia	MA 260	-	-	19-Aug-2012
Relay Switch Unit	Rohde & Schwarz	331.1601.31	338965002	-	TU
Semi Anechoic Chamber	Frankonia	23.18m×16.88m×9.60m	-	12	19-Aug-2012
Power Supply	Dahua	DH1716-5D	2007060047	-	O/P MON
Digital Multimeter	FLUKE	179	91820401	12	03-Jan-2012
Thermo-hygrometer	AZ Instruments	8705	9151655	12	16-Dec-2012



Product Service

Instrument	Manufacturer	Type No.	Serial No.	Calibration Period (months)	Calibration Due
Section 2.8 and 2.9 – Frequency Stability Under Temperature and Voltage Variations					
Spectrum Analyzer	Rohde & Schwarz	FSQ26	100253	12	27-Mar-2012
40dB Attenuator	Aeroflex / Weinschel	48-40-43-LIM	BR5020	-	O/P MON
Load	Shanghai Huaxiang	TF100	09121614	-	O/P MON
Temperature Chamber	ZUNDAR	ZT1000	10080064	-	O/P MON
Power Supply	Dahua	DH1716-5D	2007060047	-	O/P MON
Power Supply	Dahua	DH1716A-14	20080401	-	O/P MON
Digital Multimeter	FLUKE	179	91820401	12	03-Jan-2012
Thermo-hygrometer	AZ Instruments	8705	9151655	12	16-Dec-2012

O/P MON Output monitored with calibration equipment
 TU Traceability Unscheduled



Product Service

3.2 MEASUREMENT UNCERTAINTY

For a 95% confidence level, the measurement uncertainties for defined systems are:-

Test Discipline	Frequency / Parameter	MU
Conducted Maximum Peak Output Power	30MHz to 10GHz Amplitude	0.5dB*
Conducted Emissions	30MHz to 40GHz Amplitude	3.0dB*
Frequency Stability	30MHz to 2GHz Amplitude	<1x10 ⁻⁷
Radiated Emissions, Bilog Antenna, AOATS	30MHz to 1GHz Amplitude	5.1dB*
Radiated Emissions, Horn Antenna, AOATS	1GHz to 40GHz Amplitude	6.3dB*
Worst case error for both Time and Frequency measurement 12 parts in 10 ⁶		

* In accordance with CISPR 16-4



Product Service

SECTION 4

ACCREDITATION, DISCLAIMERS AND COPYRIGHT



Product Service

4.1 ACCREDITATION, DISCLAIMERS AND COPYRIGHT



This report relates only to the actual item/items tested.

Our UKAS Accreditation does not cover opinions and interpretations and any expressed are outside the scope of our UKAS Accreditation.

Results of tests not covered by our UKAS Accreditation Schedule are marked NUA
(Not UKAS Accredited).

This report must not be reproduced, except in its entirety, without the written permission of
TÜV SÜD Product Service Limited

© 2012 TÜV SÜD Product Service Limited