



Product Service

---

**Choose certainty.  
Add value.**

# Report On

FCC and Industry Canada Testing of the  
Ericsson AB  
RUG 11 B2 / KRC 161 198/1

COMMERCIAL-IN-CONFIDENCE

FCC ID: TA8AKRC161198-1  
IC ID: 287AB-AG1611981

Document 75913279 Report 01 Issue 1

May 2011



Product Service

TÜV SÜD Product Service Ltd, Octagon House, Concorde Way, Segensworth North,  
Fareham, Hampshire, United Kingdom, PO15 5RL  
Tel: +44 (0) 1489 558100. Website: [www.tuvps.co.uk](http://www.tuvps.co.uk)

COMMERCIAL-IN-CONFIDENCE

**REPORT ON**

FCC and Industry Canada Testing of the  
Ericsson AB  
RUG 11 B2 / KRC 161 198/1

Document 75913279 Report 01 Issue 1

May 2011

**PREPARED FOR**

Ericsson AB  
Torshamnsgatan 23  
SE-164 80  
Stockholm  
Sweden

**PREPARED BY**

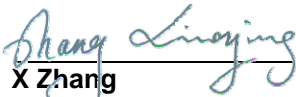
  
X Zhang  
Test Engineer

**APPROVED BY**

  
M Jenkins  
Authorised Signatory

**DATED**

27 May 2011

**ENGINEERING STATEMENT**

The measurements shown in this report were made in accordance with the procedures described on test pages. All reported testing was carried out on a sample equipment to demonstrate compliance with FCC CFR 47: Part 24 and Industry Canada RSS-133. The sample tested was found to comply with the requirements defined in the applied rules.

Test Engineer(s);

  
X Zhang

  
C Zhang





## CONTENTS

Section	Page No
<b>1</b>	<b>REPORT SUMMARY ..... 3</b>
1.1	Introduction ..... 4
1.2	Brief Summary of Results ..... 5
1.3	Declaration of Build Status ..... 9
1.4	Product Information ..... 10
1.5	Test Conditions ..... 15
1.6	Deviations From the Standard ..... 15
1.7	Modification Record ..... 15
1.8	Alternative Test Site ..... 15
<b>2</b>	<b>TEST DETAILS ..... 16</b>
2.1	Maximum Peak Output Power - Conducted ..... 17
2.2	Peak – Average Ratio ..... 22
2.3	Modulation Characteristics ..... 42
2.4	Occupied Bandwidth ..... 46
2.5	Spurious Emissions at Antenna Terminals ( $\pm 1$ MHz) ..... 54
2.6	Radiated Spurious Emissions ..... 80
2.7	Conducted Spurious Emissions ..... 85
2.8	Frequency Stability Under Temperature Variations ..... 124
2.9	Frequency Stability Under Voltage Variations ..... 127
2.10	Receiver Spurious Emissions ..... 129
<b>3</b>	<b>TEST EQUIPMENT USED ..... 135</b>
3.1	Test Equipment Used ..... 136
3.2	Measurement Uncertainty ..... 137
<b>4</b>	<b>ACCREDITATION, DISCLAIMERS AND COPYRIGHT ..... 138</b>
4.1	Accreditation, Disclaimers and Copyright ..... 139



## **SECTION 1**

### **REPORT SUMMARY**

FCC and Industry Canada Testing of the  
Ericsson AB  
RUG 11 B2 / KRC 161 198/1



## 1.1 INTRODUCTION

The information contained in this report is intended to show verification of the Ericsson AB RUG 11 B2 / KRC 161 198/1 to the requirements of FCC CFR 47 Part 24 and Industry Canada RSS-133.

Testing was carried out in support of a C2PC application for Grant of RUG 11 B2 / KRC 161 198/1 for the hardware update.

Objective	To perform FCC and Industry Canada Testing to determine the Equipment Under Test's (EUT's) compliance with the Test Specification, for the series of tests carried out.
Manufacturer	Ericsson AB
Product Name	RUG 11 B2
Part Number	KRC 161 198/1
IC Model Name	AG1611981
Serial Number(s)	CB4G584762
Software Version	CXP1040007_05P1BN
Hardware Version	R1D
Number of Samples Tested	1
Test Specification/Issue/Date	FCC CFR 47 Part 24: 2010 FCC CFR 47 Part 2: 2010 Industry Canada RSS-133: 2009
Incoming Release Date	Declaration of Build Status 17 March 2011
Order Number Date	PTP 17 March 2011
Start of Test	18 March 2011
Finish of Test	8 April 2011
Name of Engineer(s)	X Zhang C Zhang
Related Document(s)	ANSI C63.4: 2009 Industry Canada RSS-GEN Issue 3: 2010



**1.2 BRIEF SUMMARY OF RESULTS**

A brief summary of results in accordance with FCC CFR 47 Part 24 and Industry Canada RSS-133, is shown below.

Configuration 1 – UC (Hybrid Uncombined): Output 1 without internal combiner							
Section	Spec Clause		Test Description	Mode	Mod State	Result	Comments
	FCC Part 2 and 24	RSS-133 and RSS-GEN					
	24.232 (a)	6.4	Effective Radiated Power	1930.2MHz		N/A	No integral antenna.
				1960.0MHz		N/A	
				1989.8MHz		N/A	
2.1	2.1046, 24.232 (a)	6.4	Maximum Peak Output Power - Conducted	1930.2MHz	0	Pass	
				1960.0MHz	0	Pass	
				1989.8MHz	0	Pass	
2.2	24.232 (d)	-	Peak – Average Ratio	1930.2MHz	0	Pass	
				1960.0MHz	0	Pass	
				1989.8MHz	0	Pass	
2.3	2.1047 (d)	6.2	Modulation Characteristics	1930.2MHz		N/A	
				1960.0MHz	0	Pass	
				1989.8MHz		N/A	
2.4	2.1049, 24.238 (b)	RSS-Gen 4.6.1	Occupied Bandwidth	1930.2MHz	0	Pass	
				1960.0MHz	0	Pass	
				1989.8MHz	0	Pass	
2.5	2.1051, 24.238 (b)	6.5	Spurious Emissions at Antenna Terminals ( $\pm 1$ MHz)	1930.4MHz	0	Pass	The channel adjacent to the lower and higher band-edge cannot be used. The lowest usable channel is 513(1930.4MHz), the highest usable channel is 809(1989.6MHz)
				1960.0MHz		N/A	
				1989.6MHz	0	Pass	
2.6	2.1053, 24.238 (a)	6.5	Radiated Spurious Emissions	1930.2MHz		N/A	
				1960.0MHz		N/A	
				1989.8MHz		N/A	
2.7	2.1051, 24.238 (a)	6.5	Conducted Spurious Emissions	1930.2MHz	0	Pass	
				1960.0MHz	0	Pass	
				1989.8MHz	0	Pass	
2.8	2.1055, 24.235	6.3	Frequency Stability Under Temperature Variations	1930.2MHz		N/A	
				1960.0MHz	0	Pass	
				1989.8MHz		N/A	



Product Service

Configuration 1 – UC (Hybrid Uncombined): Output 1 without internal combiner							
Section	Spec Clause		Test Description	Mode	Mod State	Result	Comments
	FCC Part 2 and 24	RSS-133 and RSS-GEN					
2.9	2.1055, 24.235	6.3	Frequency Stability Under Voltage Variations	1930.2MHz		N/A	
				1960.0MHz	0	Pass	
				1989.8MHz		N/A	
2.10	-	6.6	Receiver Spurious Emissions	1930.2MHz		N/A	
				1960.0MHz		N/A	
				1989.8MHz		N/A	



Configuration 2 – TCC (Transmitter Coherent Combining): Output 1 with internal combiner plus TCC							
Section	Spec Clause		Test Description	Mode	Mod State	Result	Comments
	FCC Part 2 and 24	RSS-133 and RSS-GEN					
	24.232 (a)	6.4	Effective Radiated Power	1930.2MHz		N/A	No integral antenna.
				1960.0MHz		N/A	
				1989.8MHz		N/A	
2.1	2.1046, 24.232 (a)	6.4	Maximum Peak Output Power - Conducted	1930.2MHz	0	Pass	
				1960.0MHz	0	Pass	
				1989.8MHz	0	Pass	
2.2	24.232 (d)	-	Peak – Average Ratio	1930.2MHz	0	Pass	
				1960.0MHz	0	Pass	
				1989.8MHz	0	Pass	
2.3	2.1047 (d)	6.2	Modulation Characteristics	1930.2MHz		N/A	
				1960.0MHz		N/A	
				1989.8MHz		N/A	
2.4	2.1049, 24.238 (b)	RSS-Gen 4.6.1	Occupied Bandwidth	1930.2MHz		N/A	
				1960.0MHz		N/A	
				1989.8MHz		N/A	
2.5	2.1051, 24.238 (b)	6.5	Spurious Emissions at Antenna Terminals (±1MHz)	1930.4MHz	0	Pass	The channel adjacent to the lower and higher band-edge cannot be used. The lowest usable channel is 513(1930.4MHz), the highest usable channel is 809(1989.6MHz)
				1960.0MHz		N/A	
				1989.6MHz	0	Pass	
2.6	2.1053, 24.238 (a)	6.5	Radiated Spurious Emissions	1930.2MHz	0	Pass	
				1960.0MHz	0	Pass	
				1989.8MHz	0	Pass	
2.7	2.1051, 24.238 (a)	6.5	Conducted Spurious Emissions	1930.2MHz	0	Pass	
				1960.0MHz	0	Pass	
				1989.8MHz	0	Pass	
2.8	2.1055, 24.235	6.3	Frequency Stability Under Temperature Variations	1930.2MHz		N/A	
				1960.0MHz		N/A	
				1989.8MHz		N/A	
2.9	2.1055, 24.235	6.3	Frequency Stability Under Voltage Variations	1930.2MHz		N/A	
				1960.0MHz		N/A	
				1989.8MHz		N/A	
2.10	-	6.6	Receiver Spurious Emissions	1930.2MHz		N/A	
				1960.0MHz		N/A	
				1989.8MHz		N/A	





Configuration 3 – HC (Hybrid combined): Output 1 with internal combiner							
Section	Spec Clause		Test Description	Mode	Mod State	Result	Comments
	FCC Part 2 and 24	RSS-133 and RSS-GEN					
	24.232 (a)	6.4	Effective Radiated Power	1930.2MHz		N/A	No integral antenna.
				1960.0MHz		N/A	
				1989.8MHz		N/A	
2.1	2.1046, 24.232 (a)	6.4	Maximum Peak Output Power - Conducted	1930.2MHz	0	Pass	
				1960.0MHz	0	Pass	
				1989.8MHz	0	Pass	
2.2	24.232 (d)	-	Peak – Average Ratio	1930.2MHz	0	Pass	
				1960.0MHz	0	Pass	
				1989.8MHz	0	Pass	
2.3	2.1047 (d)	6.2	Modulation Characteristics	1930.2MHz		N/A	
				1960.0MHz		N/A	
				1989.8MHz		N/A	
2.4	2.1049, 24.238 (b)	RSS-Gen 4.6.1	Occupied Bandwidth	1930.2MHz		N/A	
				1960.0MHz		N/A	
				1989.8MHz		N/A	
2.5	2.1051, 24.238 (b)	6.5	Spurious Emissions at Antenna Terminals ( $\pm 1$ MHz)	1930.2MHz	0	Pass	The channel adjacent to the lower and higher band-edge cannot be used. The lowest usable channel is 513(1930.4MHz), the highest usable channel is 809(1989.6MHz)
				1960.0MHz		N/A	
				1989.8MHz	0	Pass	
2.6	2.1053, 24.238 (a)	6.5	Radiated Spurious Emissions	1930.2MHz		N/A	
				1960.0MHz		N/A	
				1989.8MHz		N/A	
2.7	2.1051, 24.238 (a)	6.5	Conducted Spurious Emissions	1930.2MHz	0	Pass	
				1960.0MHz	0	Pass	
				1989.8MHz	0	Pass	
2.8	2.1055, 24.235	6.3	Frequency Stability Under Temperature Variations	1930.2MHz		N/A	
				1960.0MHz		N/A	
				1989.8MHz		N/A	
2.9	2.1055, 24.235	6.3	Frequency Stability Under Voltage Variations	1930.2MHz		N/A	
				1960.0MHz		N/A	
				1989.8MHz		N/A	
2.10	-	6.6	Receiver Spurious Emissions	1930.2MHz		N/A	
				1960.0MHz	0	Pass	
				1989.8MHz		N/A	

N/A – Not Applicable



## 1.3 DECLARATION OF BUILD STATUS

<b>MAIN EUT</b>				
<b>MANUFACTURING DESCRIPTION</b>	Radio Unit			
<b>MANUFACTURER</b>	Ericsson AB			
<b>PRODUCT NAME</b>	RUG 11 B2			
<b>PART NUMBER</b>	KRC 161 198/1			
<b>IC Model Name</b>	AG1611981			
<b>SERIAL NUMBER</b>	CB4G584762			
<b>HARDWARE VERSION</b>	R1D			
<b>SOFTWARE VERSION</b>	CXP1040007_05P1BN			
<b>TRANSMITTER OPERATING RANGE</b>	TX: 1930.4MHz - 1989.6MHz RX: 1850.4MHz - 1909.6MHz			
<b>MODULATIONS</b>	GMSK, 8-PSK, 16QAM, 32QAM			
<b>INTERMEDIATE FREQUENCIES</b>	--			
<b>ITU DESIGNATION OF EMISSION</b>	250KGXW 250KG7W			
<b>OUTPUT POWER (RMS) (W or dBm)</b>	--	UC	TCC	HC
	GMSK	45.5dBm	48.0dBm	42.0dBm
	8PSK	42.2dBm	44.7dBm	38.7dBm
	16QAM	40.8dBm	43.3dBm	37.3dBm
	32QAM	40.4dBm	42.9dBm	36.9dBm
<b>OUTPUT POWER TOLERANCE</b>	±2dB			
<b>FCC ID</b>	TA8AKRC161198-1			
<b>IC ID</b>	287AB-AG1611981			
<b>TECHNICAL DESCRIPTION (a brief description of the intended use and operation)</b>	The equipment is a Radio Unit of GSM Base Station.			

Signature

Date

3 April 2011

D of B S Serial No

75913279/01

No responsibility will be accepted by TÜV SÜD Product Service Limited as to the accuracy of the information declared in this document by the manufacturer.



## 1.4 PRODUCT INFORMATION

### 1.4.1 Technical Description

The Equipment Under Test (EUT) RUG 11 B2 / KRC 161 198/1 is an Ericsson AB Radio Unit working in the public mobile service 1900MHz band which provides communication connections to GSM1900 network. The RUG 11 B2 / KRC 161 198/1 operates from a -48V DC volt supply.

The Equipment Under Test (EUT) is shown in the photograph below. A full technical description can be found in the Manufacturer's documentation.



Equipment Under Test



Product Service

#### 1.4.2 Test Configuration

##### Configuration 1 – UC (Hybrid Uncombined): Output 1 without internal combiner

The EUT was configured in accordance with FCC CFR 47 Part 24 and Industry Canada RSS-133.

##### Configuration 2 – TCC (Transmitter Coherent Combining): Output 1 with internal combiner plus TCC

The EUT was configured in accordance with FCC CFR 47 Part 24 and Industry Canada RSS-133.

##### Configuration 3 – HC (Hybrid combined): Output 1 with internal combiner

The EUT was configured in accordance with FCC CFR 47 Part 24 and Industry Canada RSS-133.

The RUG 11 B2 / KRC 161 198/1 supports GMSK, 8-PSK, 16QAM and 32QAM modulations at 1900MHz. the unit includes a maximum of two TRX's. All RF conducted TX tests were performed on one TRX RF output connector and the RX test was performed on the other TRX connector in HC configuration. The complete testing was performed with all modulation schemes at maximum RF power unless otherwise stated. The EUT was powered by a -48V DC Power supply.



**Test Setup, Conducted Measurement:**

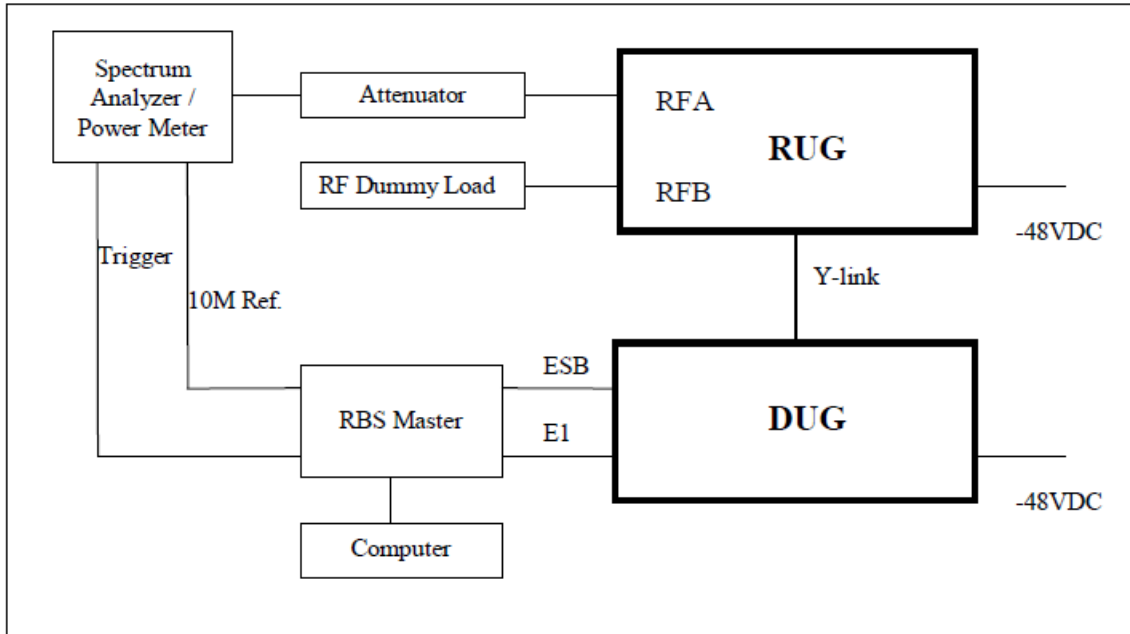

Test Object	Part Number	Version	Serial Number
Radio Part	RUG 11 B2 / KRC 161 198/1	R1D	CB4G584762

No.	Auxiliary Equipment	Part Number / Model Type	Version	Serial Number
1	Computer	HP Compaq	--	--
2	Main Unit DUG 10 01	KDU 137 597/1	R1G	C84C900362
3	RBS Master	LPY 107 1007/3	R1C	T01E655627
4	Load	TF100	--	09121642
5	Power Supply	DH1716-5D	--	2008040003
	Power Supply	DH1716A-10	--	1000303181
6	Power Meter	NRP	--	102428
	Thermal Power Sensor	NRP-Z21	--	102106
	Spectrum Analyzer	FSQ26	--	100244



**Test Setup, Radiated Measurement:**

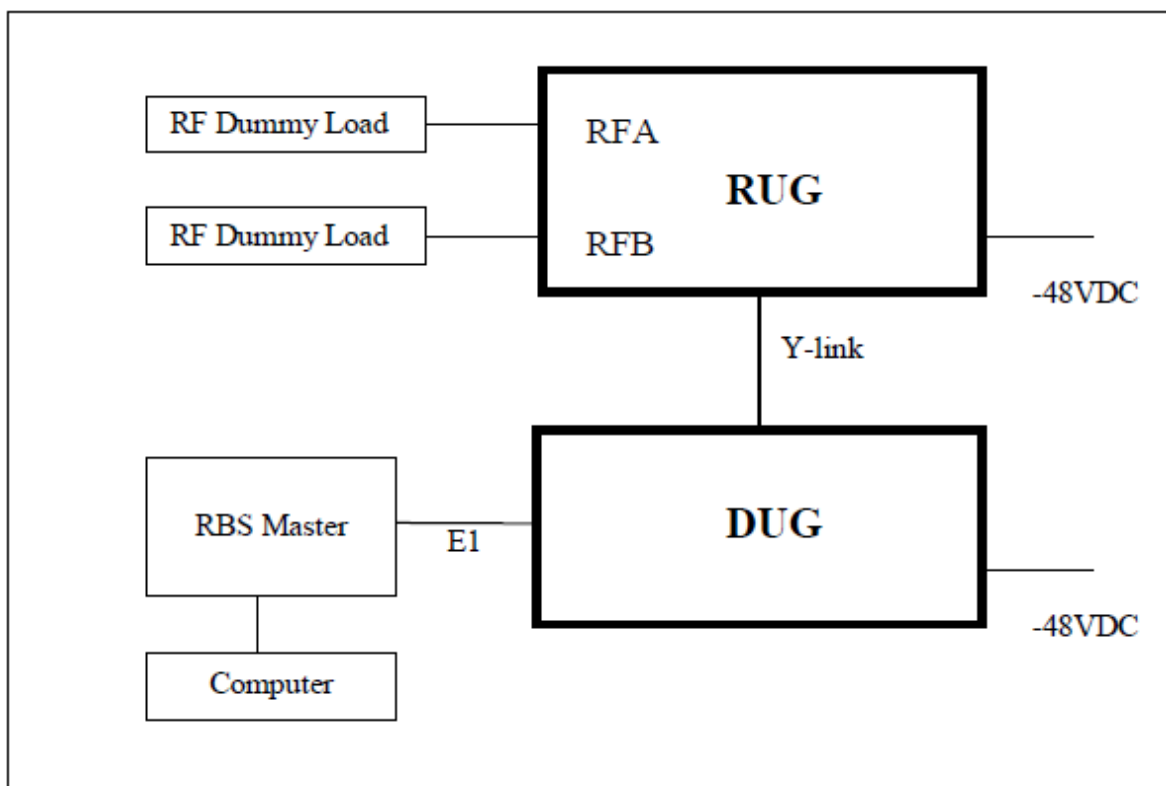

Test Object	Part Number	Version	Serial Number
Radio Part	RUG 11 B2 / KRC 161 198/1	R1D	CB4G584762

No.	Auxiliary Equipment	Part Number / Model Type	Version	Serial Number
1	Computer	HP Compaq	--	--
2	Main Unit DUG 10 01	KDU 137 597/1	R1G	C84C900362
3	RBS Master	LPY 107 1007/3	R1C	T01E655627
4	Load	TF100	--	09121642
	Load	TF100	--	09121608
5	Power Supply	DH1716-5D	--	2008040003
	Power Supply	DH1716A-10	--	1000303181



Product Service

### 1.4.3 Modes of Operation

Modes of operation of each EUT during testing were as follows:

Mode 1 - ARFCN 512: 1930.2 MHz (Bottom Channel)

Mode 2 - ARFCN 661: 1960.0 MHz (Middle Channel)

Mode 3 - ARFCN 810: 1989.8 MHz (Top Channel)

Mode 4 - ARFCN 513: 1930.4 MHz

Mode 5 - ARFCN 809: 1989.6 MHz

Information on the specific test modes utilised are detailed in the test procedure for each individual test.



Product Service

## 1.5 TEST CONDITIONS

For all tests the EUT was set up in accordance with the relevant test standard and to represent typical operating conditions. Tests were applied with the EUT situated in a shielded enclosure, test laboratories or a chamber as appropriate.

The EUT was powered from a -48V DC supply.

## 1.6 DEVIATIONS FROM THE STANDARD

No deviations from the applicable test standards or test plan were made during testing.

## 1.7 MODIFICATION RECORD

No modifications were made to the EUT during testing.

## 1.8 ALTERNATIVE TEST SITE

Testing has been performed under the following site registrations:

FCC Accreditation 910917:

The State Radio Monitoring Centre, No.80 Beilishi Road Xicheng District Beijing, China.

Industry Canada Accreditation 7308A:

The State Radio Monitoring Centre, No.80 Beilishi Road Xicheng District Beijing, China.





Product Service

## **SECTION 2**

### **TEST DETAILS**

FCC and Industry Canada Testing of the  
Ericsson AB  
RUG 11 B2 / KRC 161 198/1



Product Service

## 2.1 MAXIMUM PEAK OUTPUT POWER - CONDUCTED

### 2.1.1 Specification Reference

FCC CFR 47 Part 2, Clause 2.1046  
 FCC CFR 47 Part 24, Clause 24.232 (a)  
 Industry Canada RSS-133, Clause 6.4

### 2.1.2 Equipment Under Test

RUG 11 B2 / KRC 161 198/1, S/N: CB4G584762

### 2.1.3 Date of Test and Modification State

18 March 2011 – Modification State 0

### 2.1.4 Test Equipment Used

The major items of test equipment used for the above tests are identified in Section 3.1.

### 2.1.5 Test Method and Operating Modes

The test was applied in accordance with the test method requirements of FCC CFR 47 Part 2 and Part 24 and Industry Canada RSS-133.

Using a power meter and attenuator(s), the output power of the EUT was measured at the antenna terminal. The carrier power was measured with GMSK, 8-PSK, 16QAM and 32QAM using the test model described.

The path loss was measured and entered as a reference level offset.

The test was performed with the EUT in the following configurations and modes of operation:

Configuration 1 - Mode 1  
                           - Mode 2  
                           - Mode 3  
 Configuration 2 - Mode 1  
                           - Mode 2  
                           - Mode 3  
 Configuration 3 - Mode 1  
                           - Mode 2  
                           - Mode 3

### 2.1.6 Environmental Conditions

	18 March 2011
Ambient Temperature	25.0°C
Relative Humidity	34.0%



### 2.1.7 Test Results

For the period of test the EUT met the requirements of FCC CFR 47 Part 2 and Part 24 and Industry Canada RSS-133 for Maximum Peak Output Power.

The test results are shown below

#### GMSK

##### Configuration 1 - Mode 1, 2 and 3

Channel	Frequency (MHz)	Path Loss (dB)	Result (dBm) RMS	Result (W) RMS
Bottom	1930.2	42.2	45.74	37.50
Middle	1960.0	42.2	45.77	37.76
Top	1989.8	42.2	45.77	37.76

##### Configuration 2 - Mode 1, 2 and 3

Channel	Frequency (MHz)	Path Loss (dB)	Result (dBm) RMS	Result (W) RMS
Bottom	1930.2	42.2	48.41	69.34
Middle	1960.0	42.2	48.50	70.79
Top	1989.8	42.2	48.50	70.79

##### Configuration 3 - Mode 1, 2 and 3

Channel	Frequency (MHz)	Path Loss (dB)	Result (dBm) RMS	Result (W) RMS
Bottom	1930.2	42.2	42.61	18.24
Middle	1960.0	42.2	42.66	18.45
Top	1989.8	42.2	42.63	18.32

**8PSK**Configuration 1 - Mode 1, 2 and 3

Channel	Frequency (MHz)	Path Loss (dB)	Result (dBm) RMS	Result (W) RMS
Bottom	1930.2	42.2	42.53	17.91
Middle	1960.0	42.2	42.55	17.99
Top	1989.8	42.2	42.53	17.91

Configuration 2 - Mode 1, 2 and 3

Channel	Frequency (MHz)	Path Loss (dB)	Result (dBm) RMS	Result (W) RMS
Bottom	1930.2	42.2	45.20	33.11
Middle	1960.0	42.2	45.22	33.27
Top	1989.8	42.2	45.20	33.11

Configuration 3 - Mode 1, 2 and 3

Channel	Frequency (MHz)	Path Loss (dB)	Result (dBm) RMS	Result (W) RMS
Bottom	1930.2	42.2	39.34	8.59
Middle	1960.0	42.2	39.36	8.63
Top	1989.8	42.2	39.34	8.59

**16QAM****Configuration 1 - Mode 1, 2 and 3**

Channel	Frequency (MHz)	Path Loss (dB)	Result (dBm) RMS	Result (W) RMS
Bottom	1930.2	42.2	41.30	13.49
Middle	1960.0	42.2	41.34	13.61
Top	1989.8	42.2	41.35	13.65

**Configuration 2 - Mode 1, 2 and 3**

Channel	Frequency (MHz)	Path Loss (dB)	Result (dBm) RMS	Result (W) RMS
Bottom	1930.2	42.2	43.96	24.89
Middle	1960.0	42.2	43.98	25.00
Top	1989.8	42.2	44.06	25.47

**Configuration 3 - Mode 1, 2 and 3**

Channel	Frequency (MHz)	Path Loss (dB)	Result (dBm) RMS	Result (W) RMS
Bottom	1930.2	42.2	38.12	6.49
Middle	1960.0	42.2	38.15	6.53
Top	1989.8	42.2	38.11	6.47

**32QAM****Configuration 1 - Mode 1, 2 and 3**

Channel	Frequency (MHz)	Path Loss (dB)	Result (dBm) RMS	Result (W) RMS
Bottom	1930.2	42.2	40.28	10.67
Middle	1960.0	42.2	40.33	10.79
Top	1989.8	42.2	40.35	10.84

**Configuration 2 - Mode 1, 2 and 3**

Channel	Frequency (MHz)	Path Loss (dB)	Result (dBm) RMS	Result (W) RMS
Bottom	1930.2	42.2	42.98	19.86
Middle	1960.0	42.2	43.02	20.04
Top	1989.8	42.2	43.10	20.42

**Configuration 3 - Mode 1, 2 and 3**

Channel	Frequency (MHz)	Path Loss (dB)	Result (dBm) RMS	Result (W) RMS
Bottom	1930.2	42.2	37.13	5.16
Middle	1960.0	42.2	37.12	5.15
Top	1989.8	42.2	37.18	5.22

Limit	≤100W or ≤+50dBm
-------	------------------

**Remarks**

The EUT does not exceed 100W or 50dBm at the measured frequencies.



Product Service

## 2.2 PEAK – AVERAGE RATIO

### 2.2.1 Specification Reference

FCC CFR 47 Part 24, Clause 24.232 (d)

### 2.2.2 Equipment Under Test

RUG 11 B2 / KRC 161 198/1, S/N: CB4G584762

### 2.2.3 Date of Test and Modification State

21 March 2011 – Modification State 0

### 2.2.4 Test Equipment Used

The major items of test equipment used for the above tests are identified in Section 3.1.

### 2.2.5 Test Method and Operating Modes

The test was applied in accordance with the test method requirements of FCC CFR 47 Part 24.

A peak to average ratio measurement is performed at the conducted port of the EUT. The spectrum analyzers Complementary Cumulative Distribution Function (CCDF) measurement profile is used to determine the largest deviation between the average and the peak power of the EUT in given bandwidth. The CCDF curve shows how much time the peak waveform spends at or above a given average power level. The percent of time the signal spends at or above the level defines the probability for that particular power level.

The path loss is measured and entered as a reference level offset.

The test was performed with the EUT in the following configurations and modes of operation:

Configuration 1	- Mode 1
	- Mode 2
	- Mode 3
Configuration 2	- Mode 1
	- Mode 2
	- Mode 3
Configuration 3	- Mode 1
	- Mode 2
	- Mode 3

### 2.2.6 Environmental Conditions

	21 March 2011
Ambient Temperature	24.3°C
Relative Humidity	24.5%



Product Service

**2.2.7 Test Results**

For the period of test the EUT met the requirements of FCC CFR 47 Part 24 Peak – Average Ratio.

The test results are shown below.

**GMSK**

**Configuration 1 - Mode 1**

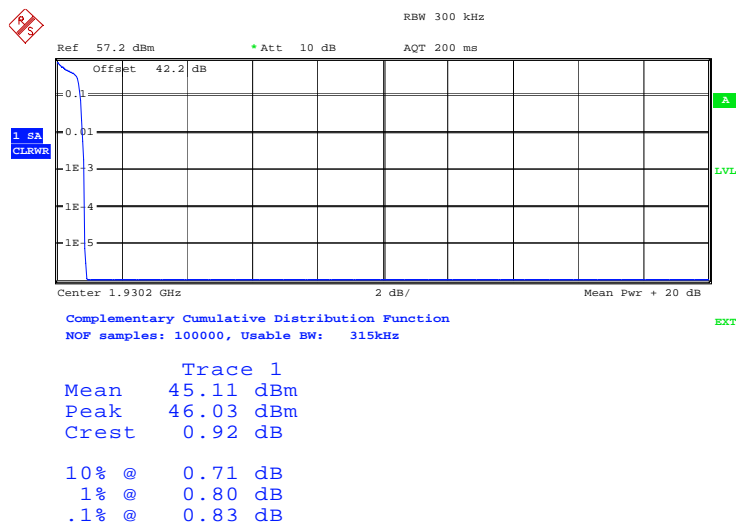

Date: 21.MAR.2011 08:55:22





Configuration 1 - Mode 2

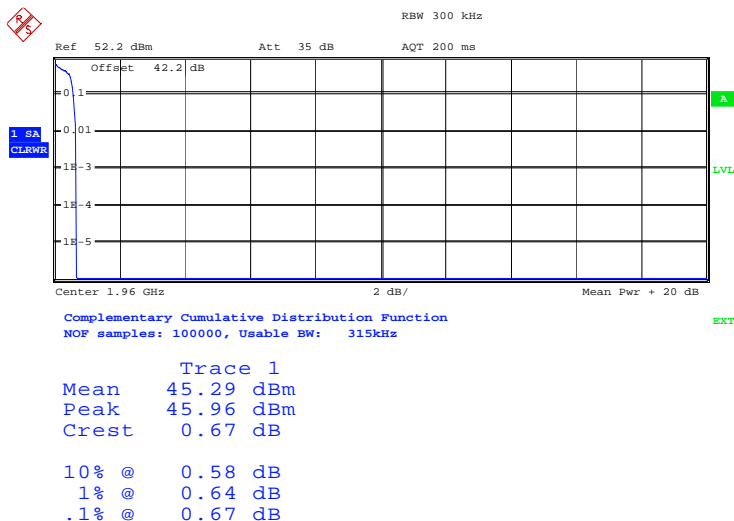

Date: 21.MAR.2011 09:22:59

Configuration 1 - Mode 3

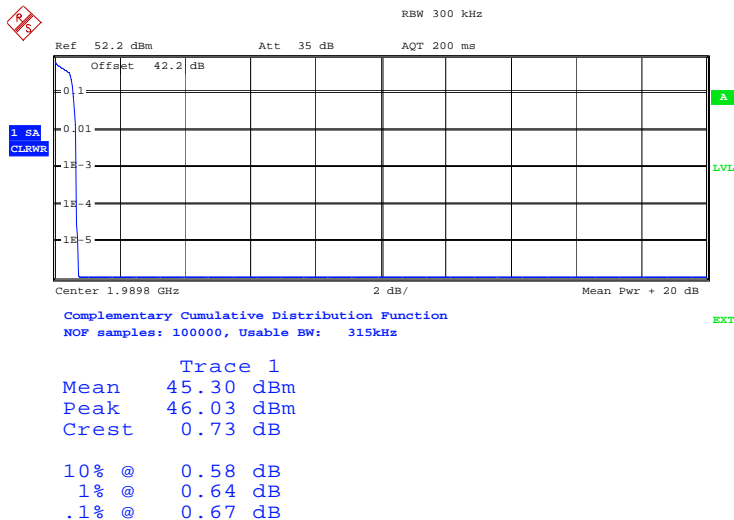

Date: 21.MAR.2011 09:23:48



Product Service

### Configuration 2 - Mode 1

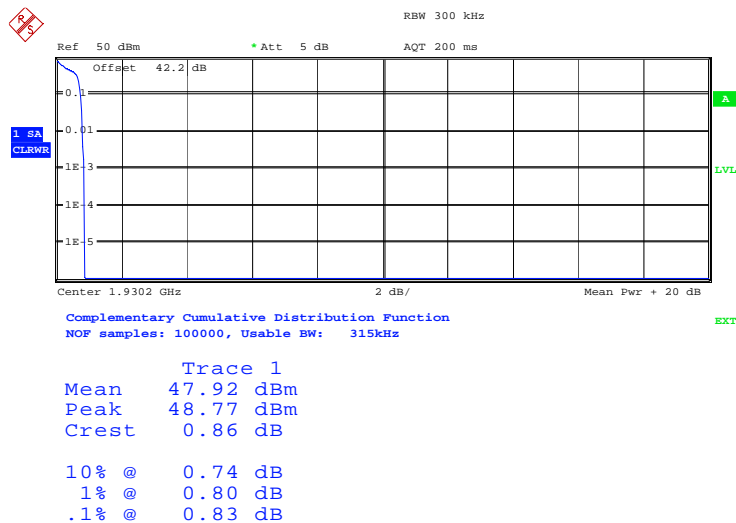

Date: 22.MAR.2011 08:34:16

### Configuration 2 - Mode 2

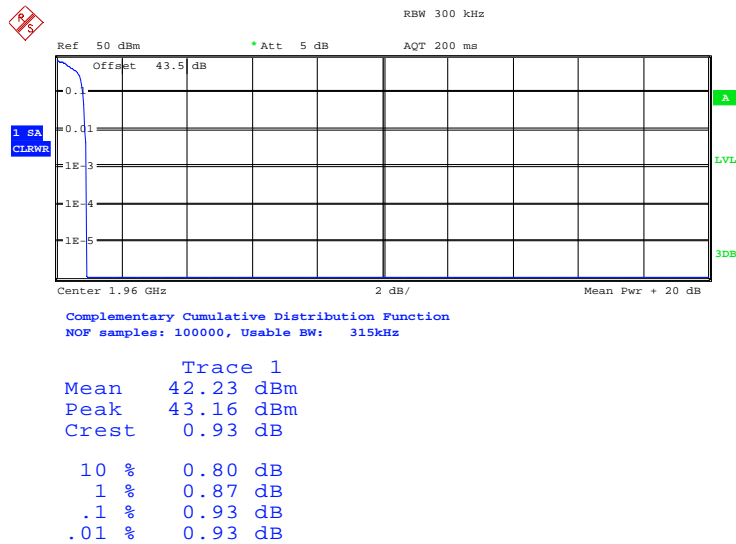

Date: 13.APR.2011 05:20:15



Product Service

**Configuration 2 - Mode 3**

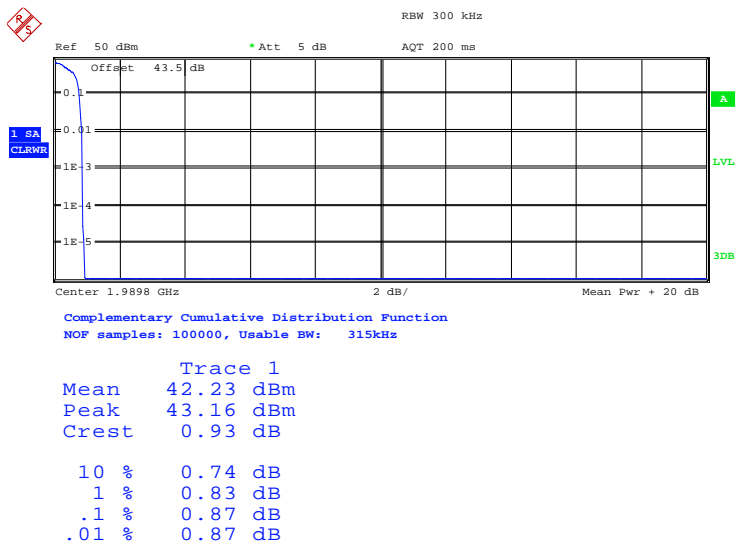

Date: 13.APR.2011 05:19:25

**Configuration 3 - Mode 1**

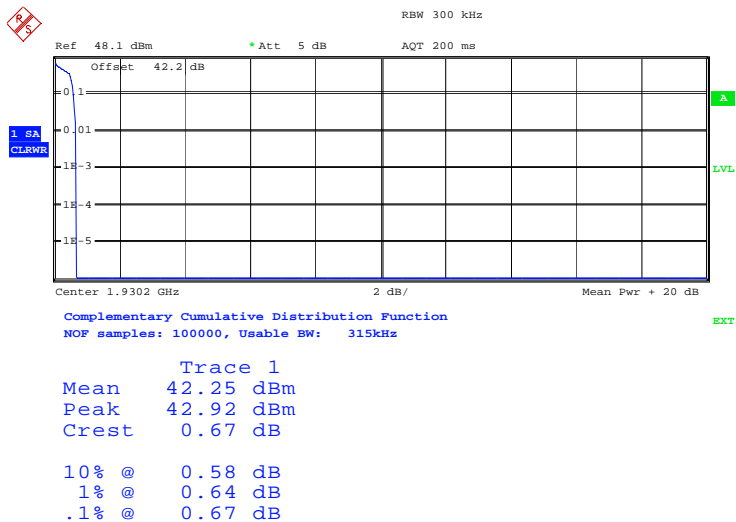

Date: 22.MAR.2011 08:51:52



Product Service

### Configuration 3 - Mode 2

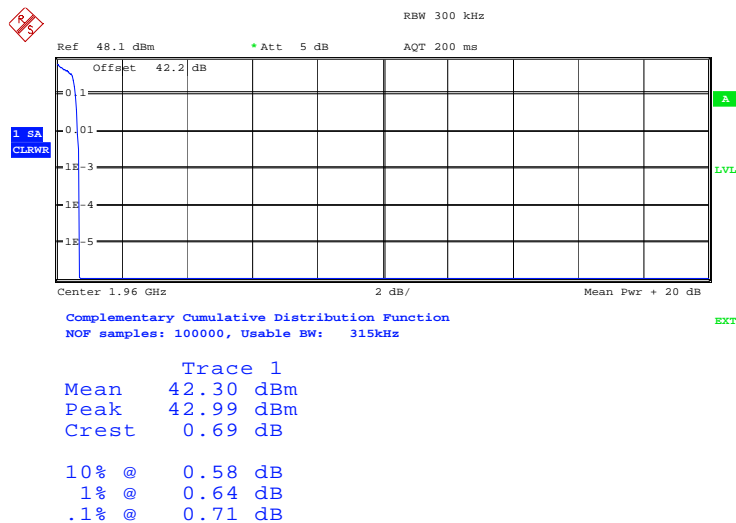

Date: 22.MAR.2011 08:53:03

### Configuration 3 - Mode 3

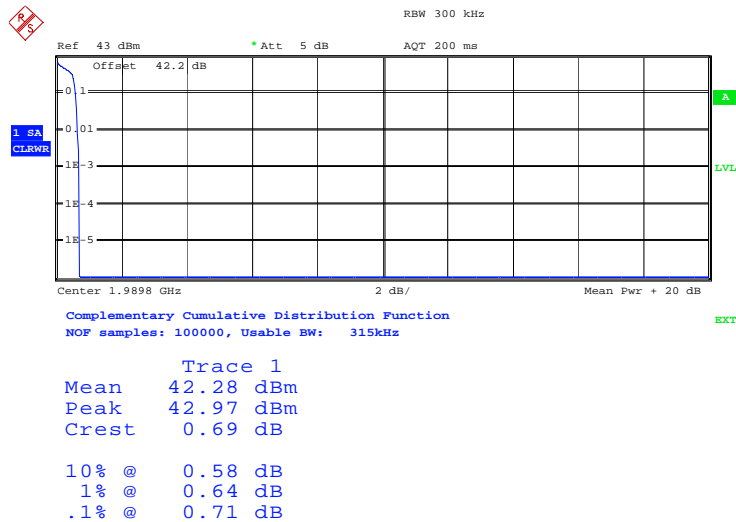

Date: 22.MAR.2011 08:58:44



Product Service

### 8-PSK

#### Configuration 1 - Mode 1

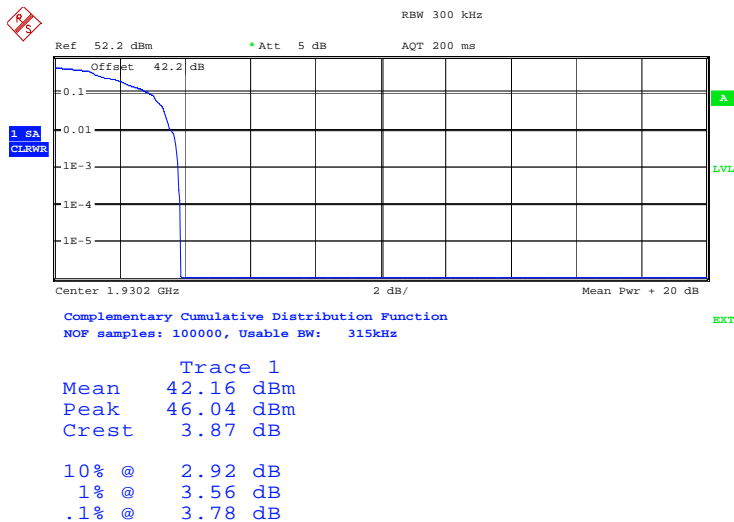

Date: 21.MAR.2011 09:55:29

#### Configuration 1 - Mode 2

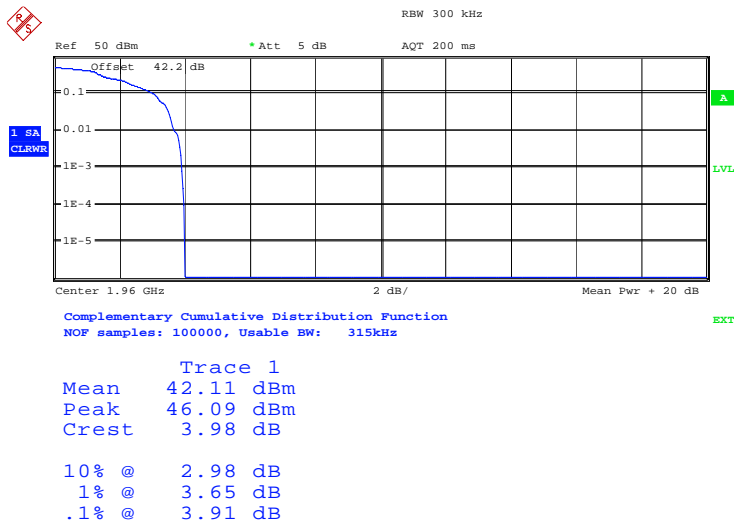

Date: 21.MAR.2011 09:57:22



### Configuration 1 - Mode 3

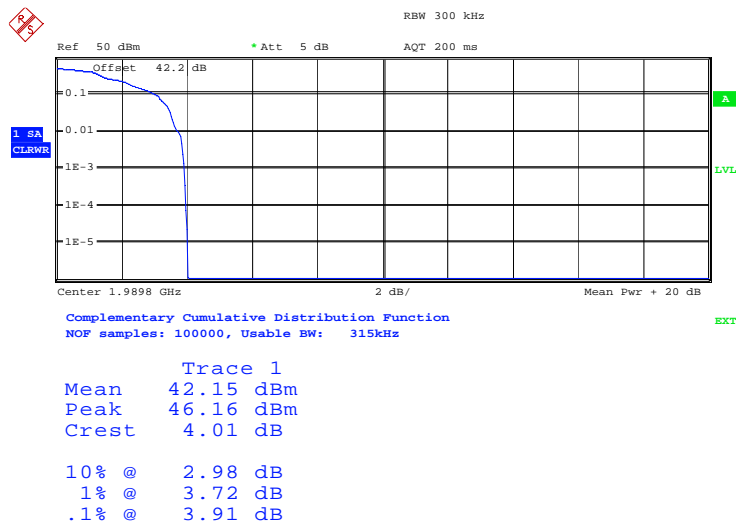

Date: 21.MAR.2011 11:43:58

### Configuration 2 - Mode 1

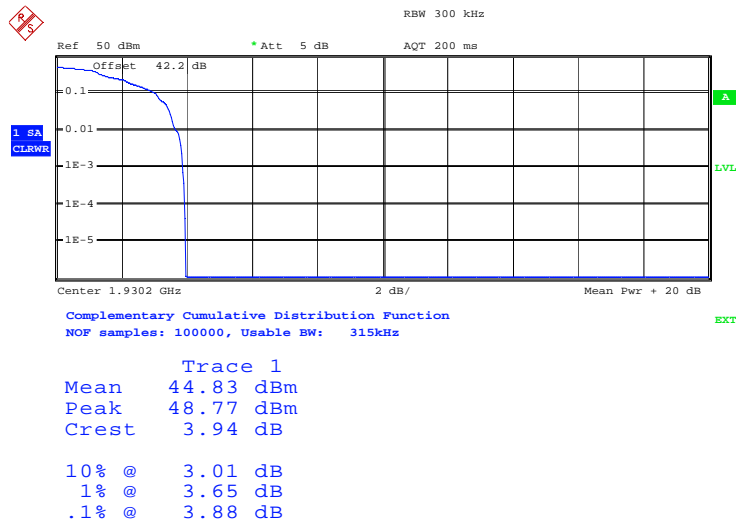

Date: 22.MAR.2011 08:33:20



Configuration 2 - Mode 2

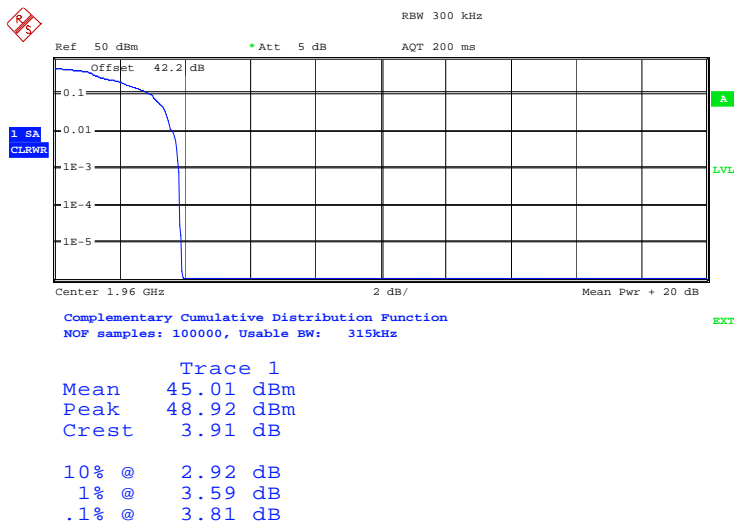

Date: 22.MAR.2011 08:22:55

Configuration 2 - Mode 3

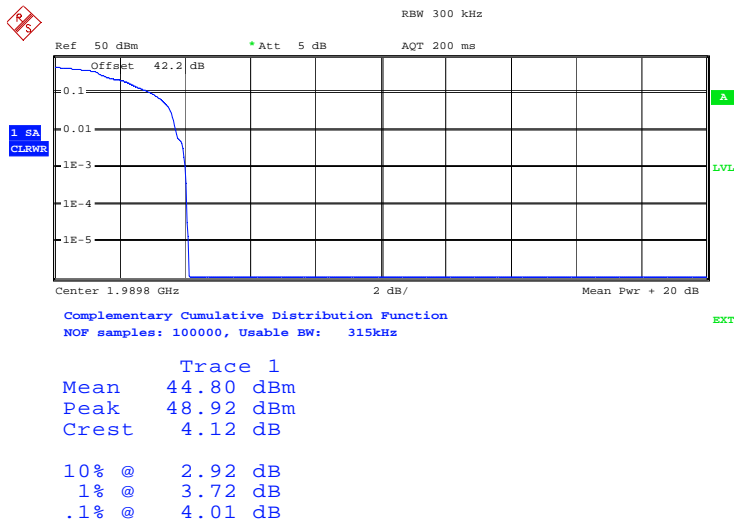

Date: 22.MAR.2011 08:21:51



Configuration 3 - Mode 1

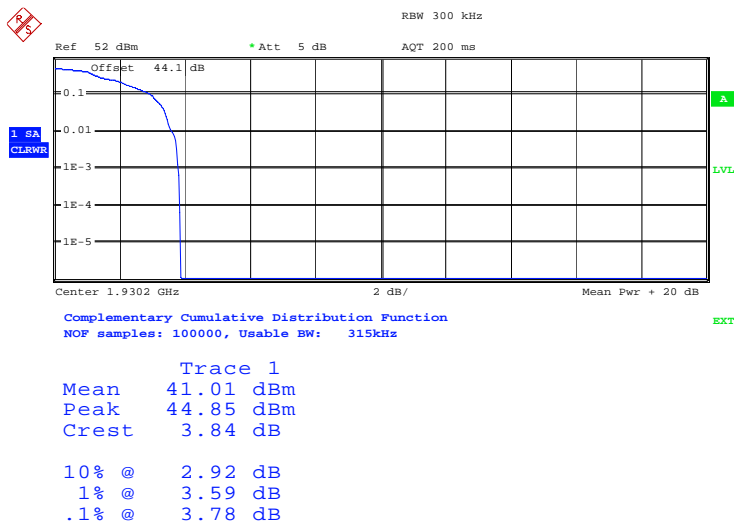

Date: 22.MAR.2011 09:04:34

Configuration 3 - Mode 2

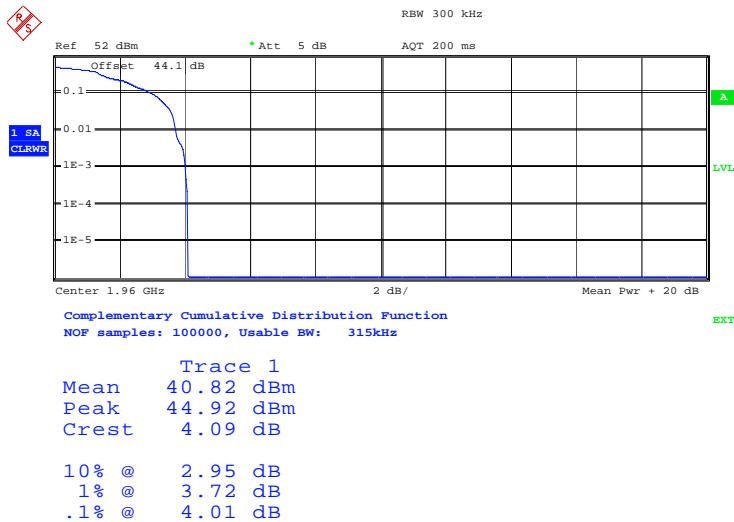

Date: 22.MAR.2011 09:03:33





**Configuration 3 - Mode 3**

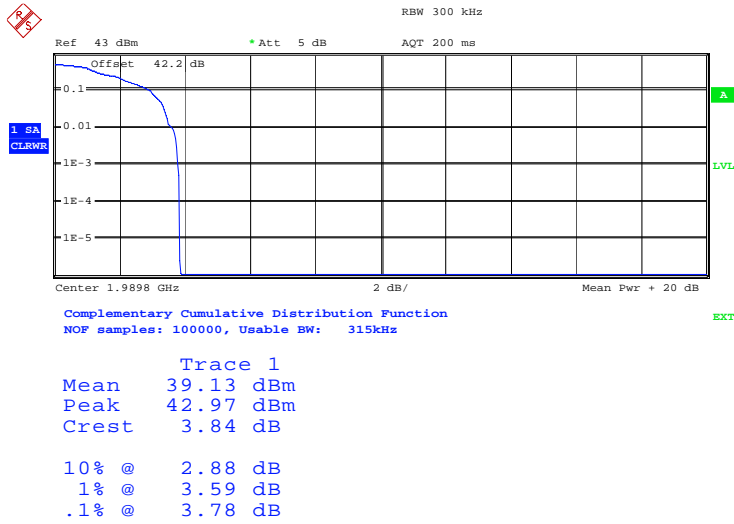

Date: 22.MAR.2011 08:59:43

**16QAM**

**Configuration 1 - Mode 1**

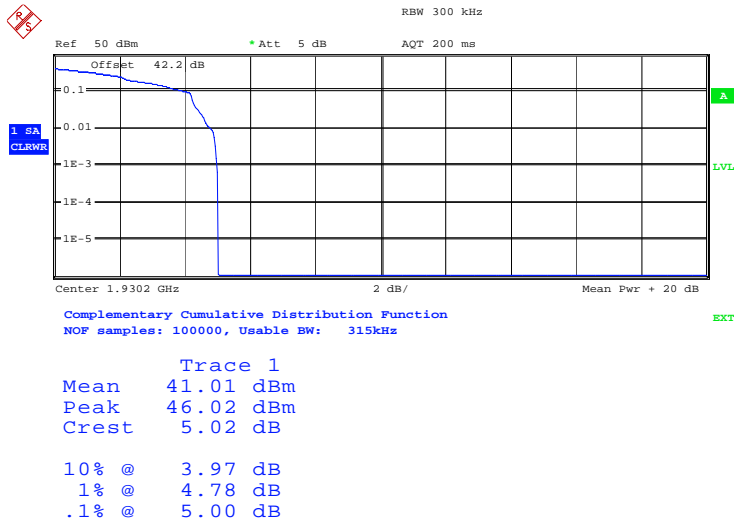

Date: 21.MAR.2011 11:46:22



Configuration 1 - Mode 2

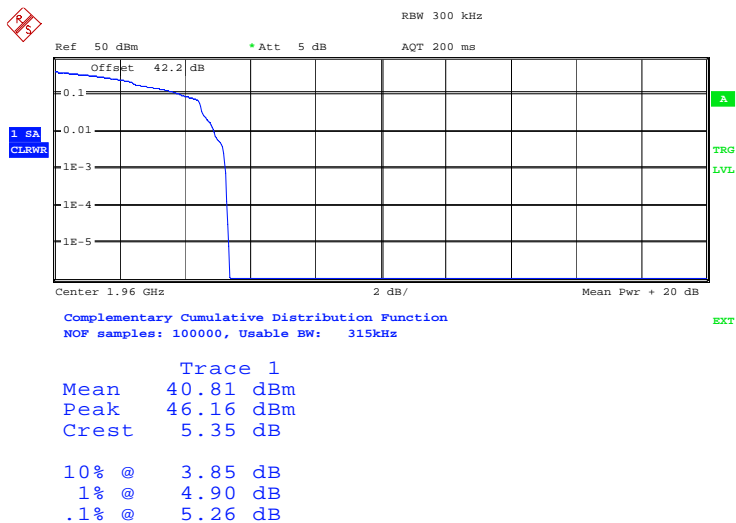

Date: 21.MAR.2011 13:12:17

Configuration 1 - Mode 3

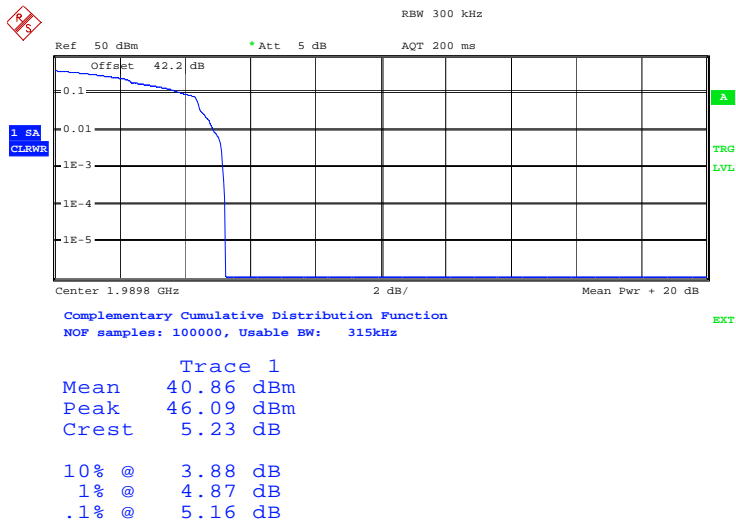

Date: 21.MAR.2011 13:13:15



Configuration 2 - Mode 1

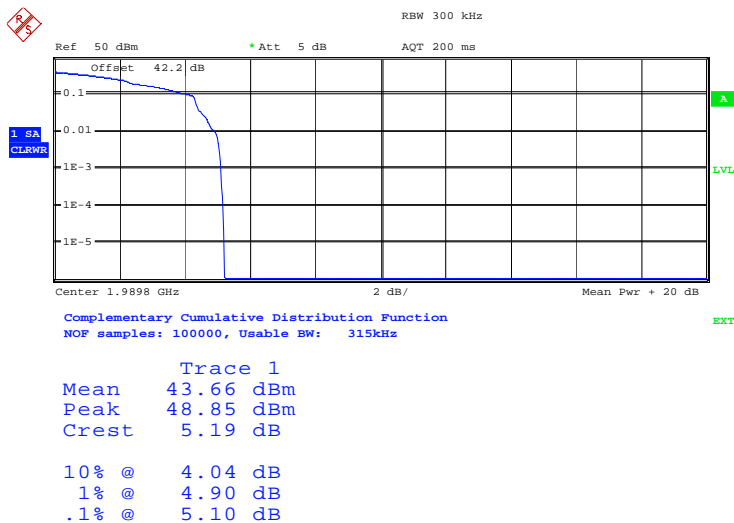

Configuration 2 - Mode 2

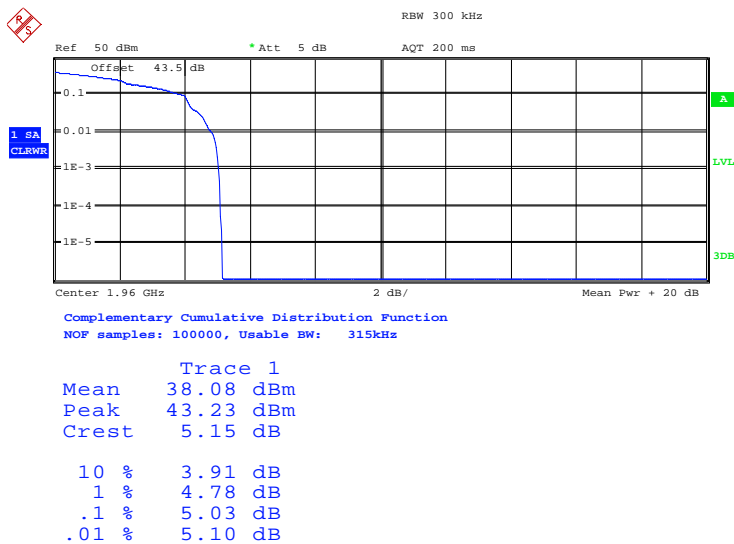



**Configuration 2 - Mode 3**

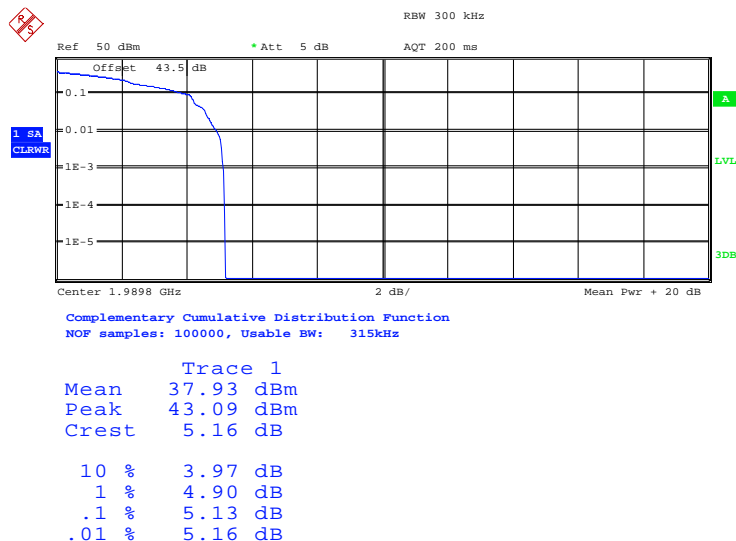

Date: 13.APR.2011 05:18:36

**Configuration 3 - Mode 1**

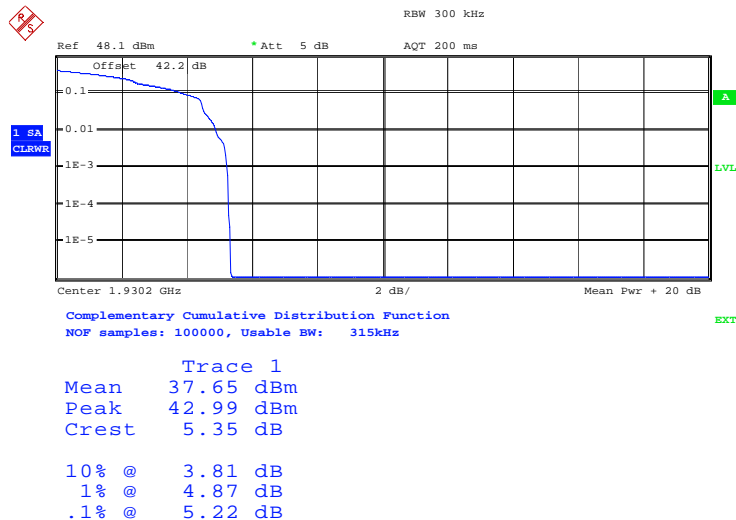

Date: 22.MAR.2011 09:09:42



Configuration 3 - Mode 2

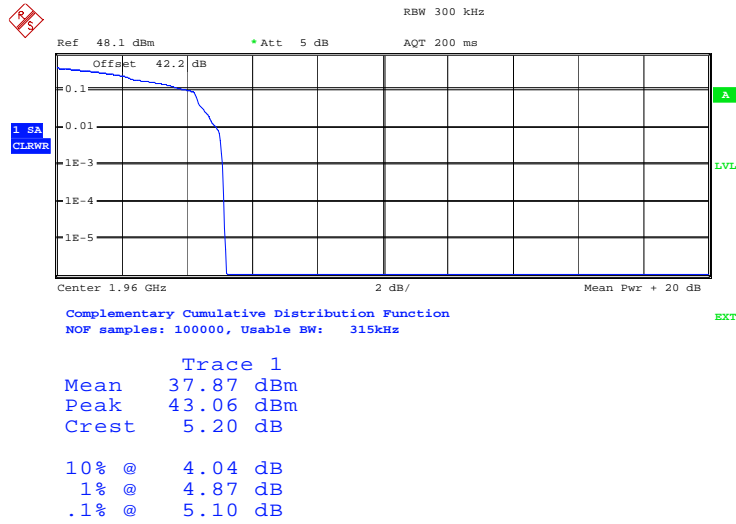

Date: 22.MAR.2011 09:12:11

Configuration 3 - Mode 3

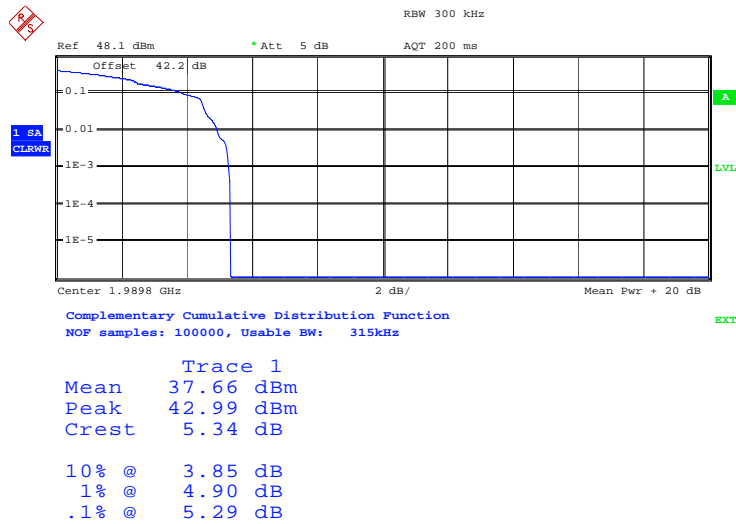

Date: 22.MAR.2011 09:23:36



Product Service

### 32QAM

#### Configuration 1 - Mode 1

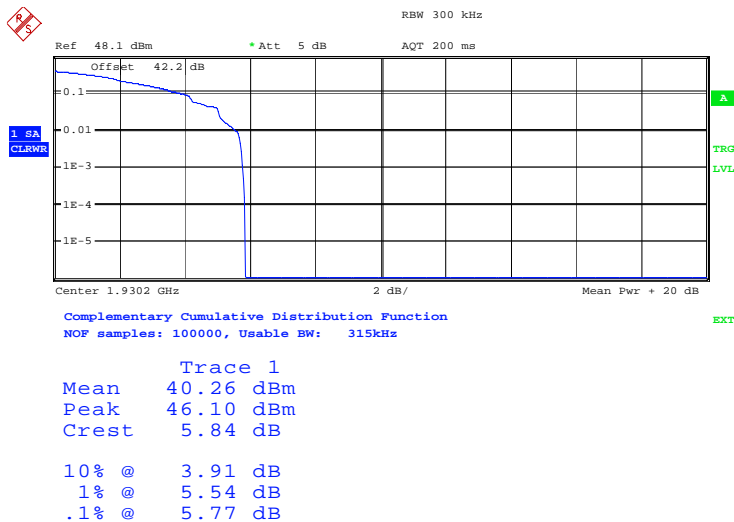

Date: 21.MAR.2011 14:07:55

#### Configuration 1 - Mode 2

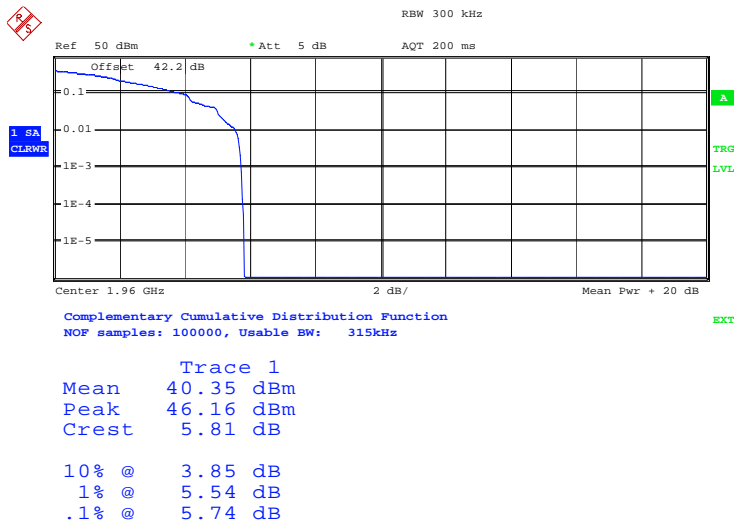

Date: 21.MAR.2011 13:22:34



### Configuration 1 - Mode 3

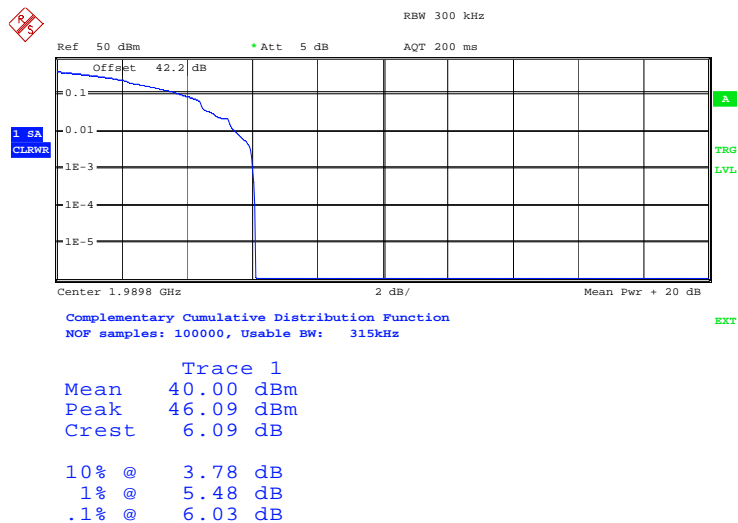

Date: 21.MAR.2011 13:20:51

### Configuration 2 - Mode 1

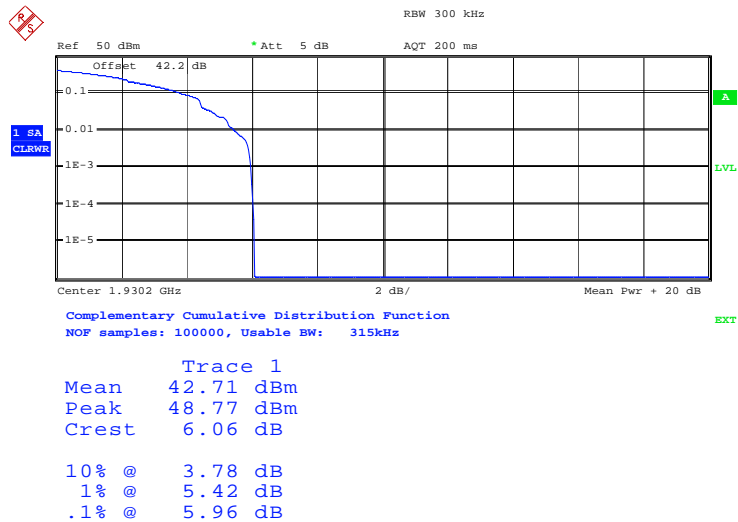

Date: 21.MAR.2011 15:34:53



Configuration 2 - Mode 2

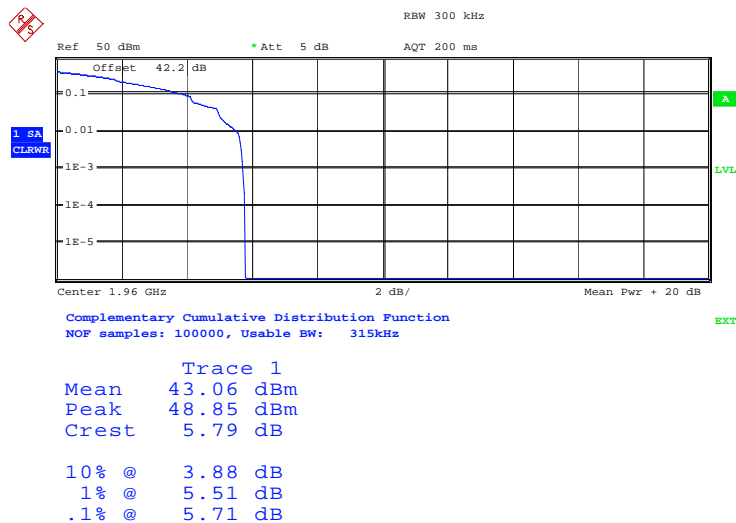

Date: 21.MAR.2011 15:36:01

Configuration 2 - Mode 3

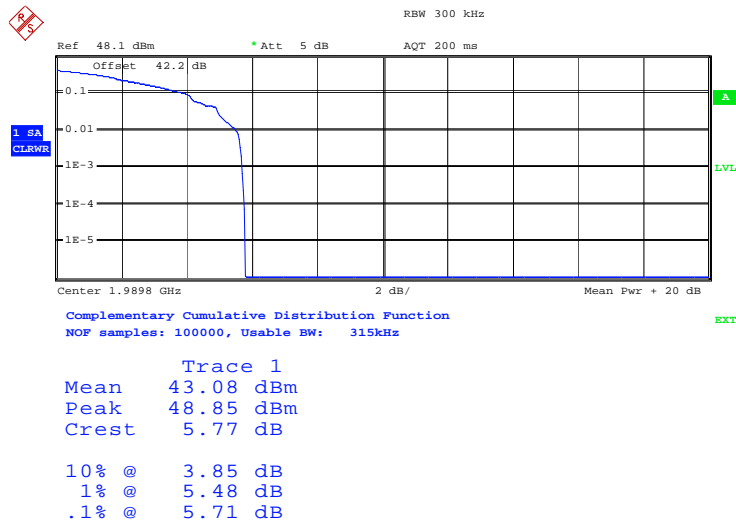

Date: 21.MAR.2011 15:39:44





### Configuration 3 - Mode 1

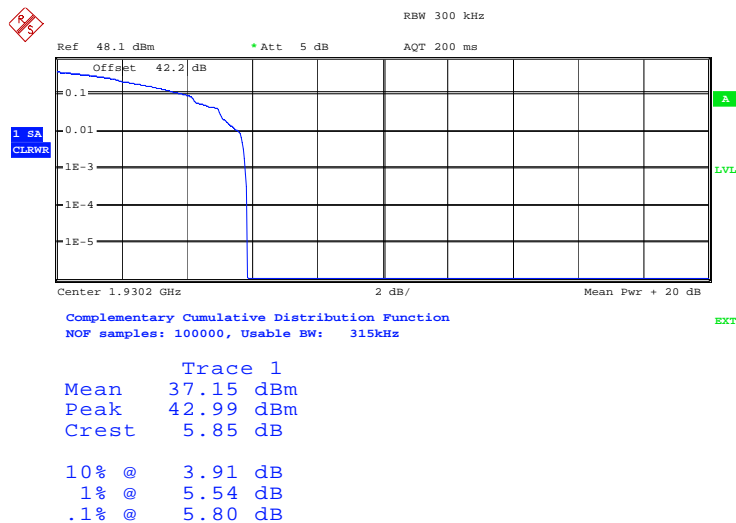

Date: 22.MAR.2011 09:34:14

### Configuration 3 - Mode 2

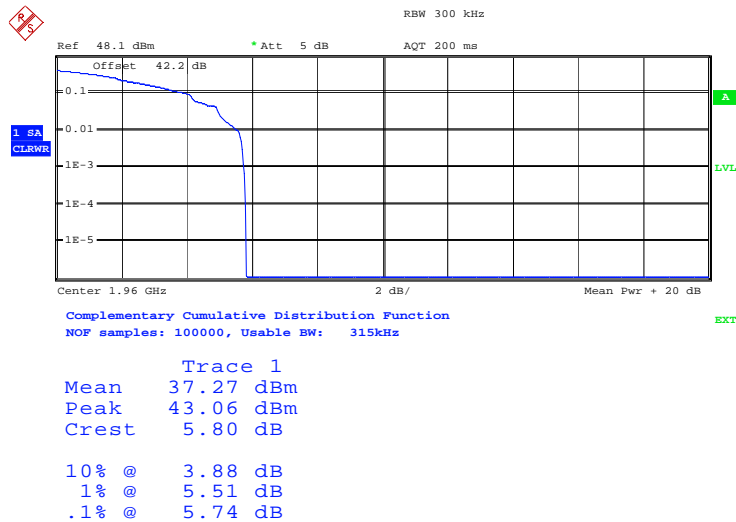

Date: 22.MAR.2011 09:32:58



Product Service

Configuration 3 - Mode 3

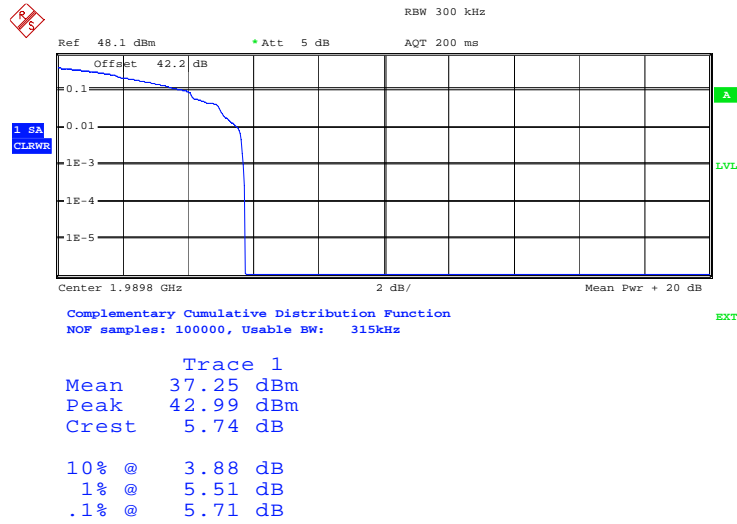

Date: 22.MAR.2011 09:24:26

Limit	13dB
-------	------

Remarks

The Peak – Average ratio does not exceed 13dB at the measured frequencies.



Product Service

## **2.3 MODULATION CHARACTERISTICS**

### **2.3.1 Specification Reference**

FCC CFR 47 Part 2, Clause 2.1047 (d)  
Industry Canada RSS-133 Clause 6.2

### **2.3.2 Equipment Under Test**

RUG 11 B2 / KRC 161 198/1, S/N: CB4G584762

### **2.3.3 Date of Test and Modification State**

23 March 2011 – Modification State 0

### **2.3.4 Test Method and Operating Modes**

The test was applied in accordance with the test method requirements of FCC CFR 47 Part 2 and Industry Canada RSS-133.

The EUT supports GMSK, 8-PSK, 16QAM and 32QAM modulations.

The test was performed with the EUT in the following configurations and modes of operation:

Configuration 1 - Mode 2

### **2.3.5 Environmental Conditions**

	23 March 2011
Ambient Temperature	26.8°C
Relative Humidity	20.0%



Product Service

**2.3.6 Test Results**

For the period of test the EUT met the requirements of FCC CFR 47 Part 2 and Industry Canada RSS-133 for Modulation Characteristics.

The test results are shown below

**Configuration 1 - Mode 2**

**GMSK**

GSM / EDGE / EDGE Evolution					
Frequency	ARFCN 661 (1.96 GHz)	Ref Level	46.2 dBm, Att 10 dB	External Att	40 dB
Device Type	BTS Normal, PCS 1900	Trigger	Ext, Offset 19.77 衞	Slot	0 (NB, GMSK)

A: Constellation: Graph

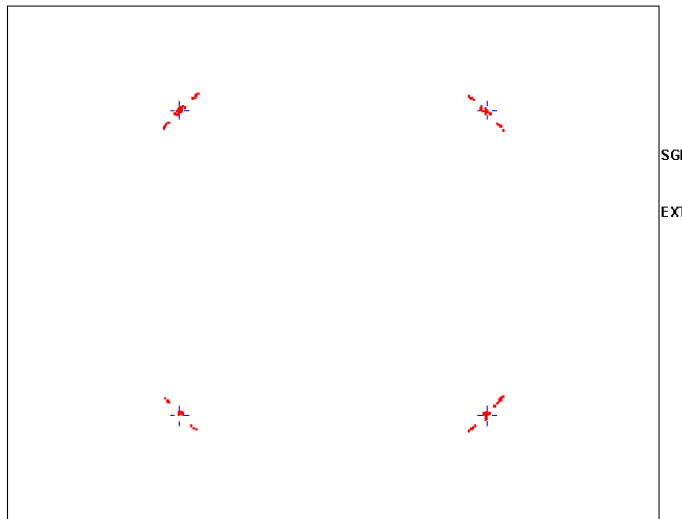

B: Constellation: Modulation Accuracy

	Current	Unit

Date: 23.MAR.2011 10:14:15



**8-PSK**

GSM / EDGE / EDGE Evolution					
Frequency	ARFCN 661 (1.96 GHz)	Ref Level	46.2 dBm, Att 10 dB	External Att	40 dB
Device Type	BTS Normal, PCS 1900	Trigger	Ext, Offset 19.77 衞	Slot	0 (NB, 8PSK)

A: Constellation: Graph

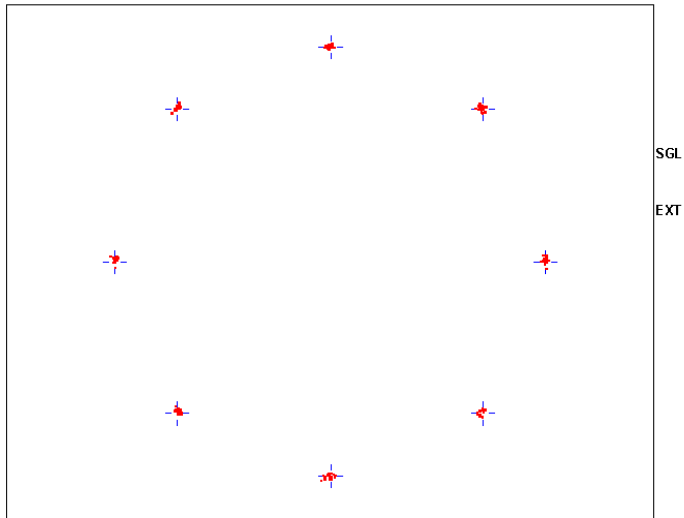

B: Constellation: Modulation Accuracy			
	Current	Unit	
BER	1.04	%	

Date: 23.MAR.2011 10:13:31

**16QAM**

GSM / EDGE / EDGE Evolution					
Frequency	ARFCN 661 (1.96 GHz)	Ref Level	46.2 dBm, Att 10 dB	External Att	40 dB
Device Type	BTS Normal, PCS 1900	Trigger	Ext, Offset 19.77 衞	Slot	0 (NB, 16QAM)

A: Constellation: Graph

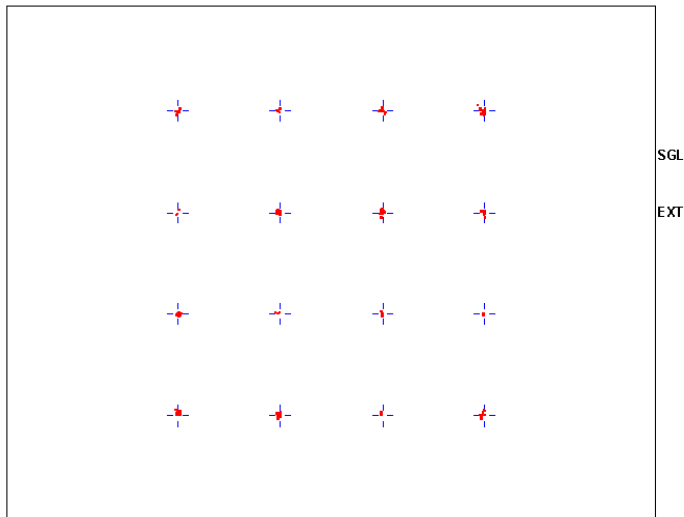

B: Constellation: Modulation Accuracy			
	Current	Unit	
BER	1.43	%	

Date: 23.MAR.2011 10:12:24



Product Service

**32QAM**

GSM / EDGE / EDGE Evolution					
<b>Frequency</b>	ARFCN 661 (1.96 GHz)	<b>Ref Level</b>	46.6 dBm, Att 10 dB	<b>External Att</b>	40 dB
<b>Device Type</b>	BTS Normal, PCS 1900	<b>Trigger</b>	Ext, Offset 19.77 衞	<b>Slot</b>	0 (NB, 32 QAM)

A: Constellation: Graph

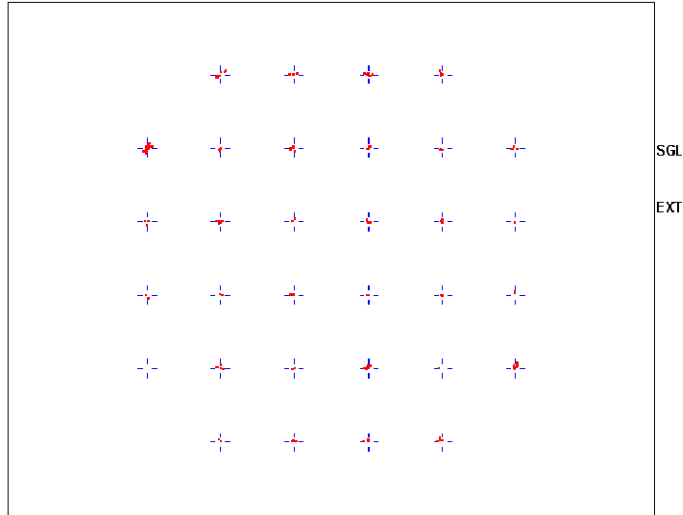

B: Constellation: Modulation Accuracy

	Current	Unit
BER	0.00	%

Date: 23.MAR.2011 10:10:03



Product Service

## **2.4 OCCUPIED BANDWIDTH**

### **2.4.1 Specification Reference**

FCC CFR 47 Part 2, Clause 2.1049  
FCC CFR 47 Part 24, Clause 24.238 (b)  
Industry Canada RSS-GEN, Clause 4.6.1

### **2.4.2 Equipment Under Test**

RUG 11 B2 / KRC 161 198/1, S/N: CB4G584762

### **2.4.3 Date of Test and Modification State**

21 March 2011 – Modification State 0

### **2.4.4 Test Equipment Used**

The major items of test equipment used for the above tests are identified in Section 3.1.

### **2.4.5 Test Method and Operating Modes**

The test was applied in accordance with the test method requirements of FCC CFR 47 Part 2 and Part 24 and Industry Canada RSS-GEN.

The EUT was transmitting at maximum power, modulated with all timeslots active. Using a resolution bandwidth of 3kHz and a video bandwidth of 30kHz. The occupied bandwidth, that is the frequency bandwidth such that, below its lower and above its upper frequency limits, the mean powers radiated are each equal to 0.5 percent of the total mean power radiated by a given emission. The -26dBc points were also established and the emission bandwidth determined.

The test was performed with the EUT in the following configurations and modes of operation:

Configuration 1 - Mode 1  
                          - Mode 2  
                          - Mode 3

### **2.4.6 Environmental Conditions**

21 March 2011  
Ambient Temperature 24.3°C  
Relative Humidity 24.5%



**2.4.7 Test Results**

For the period of test the EUT met the requirements of FCC CFR 47 Part 2 and Part 24 and Industry Canada RSS-GEN for Occupied Bandwidth.

The test results are shown below

**Configuration 1 - Mode 1**

**GMSK**

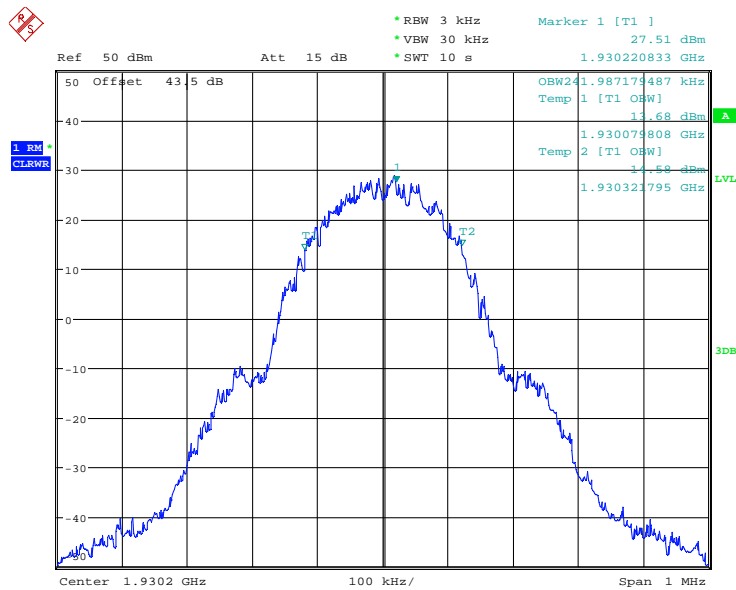

Date: 13.APR.2011 05:24:47





Product Service

### 8-PSK

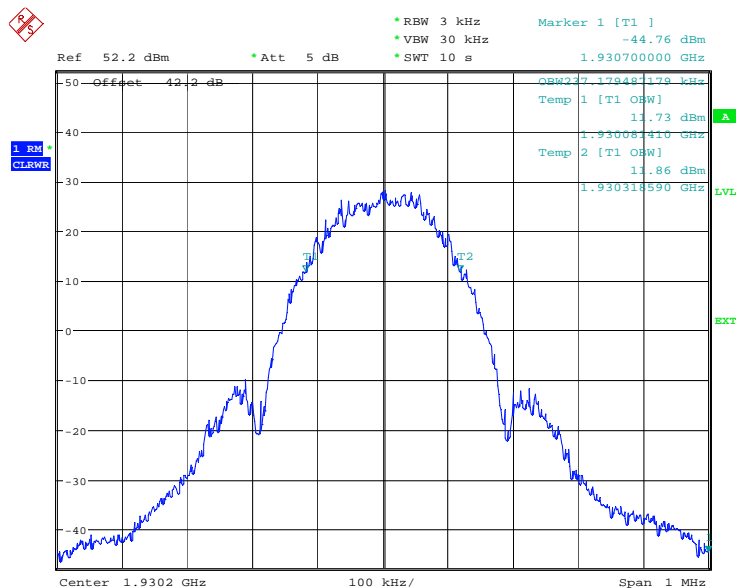

Date: 21.MAR.2011 09:54:15

### 16QAM

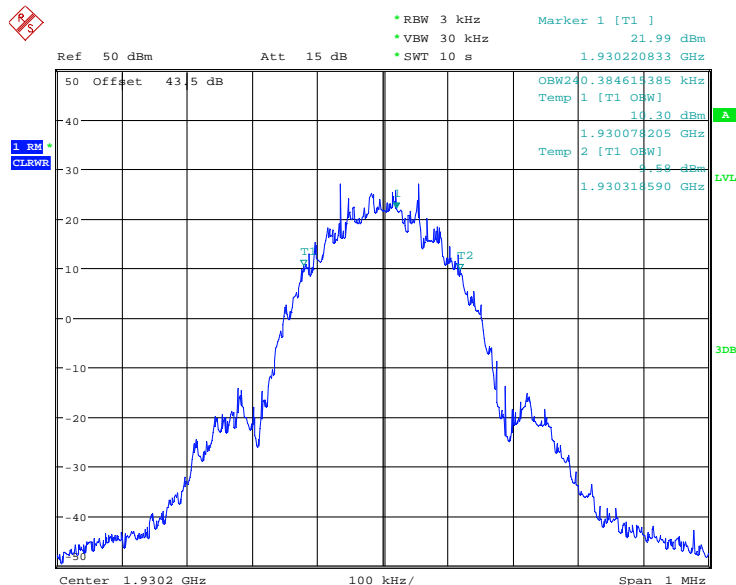

Date: 13.APR.2011 05:26:04



**32QAM**

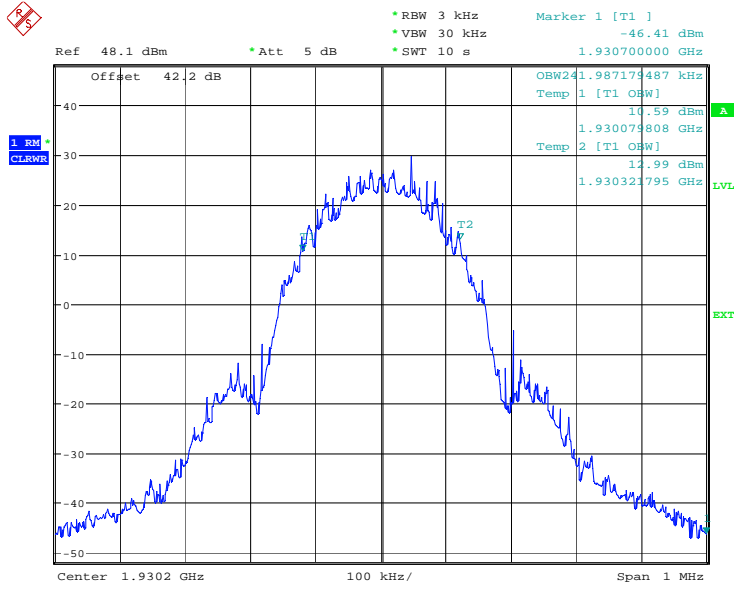

Date: 21.MAR.2011 14:07:07

**Configuration 1 - Mode 2**

**GMSK**

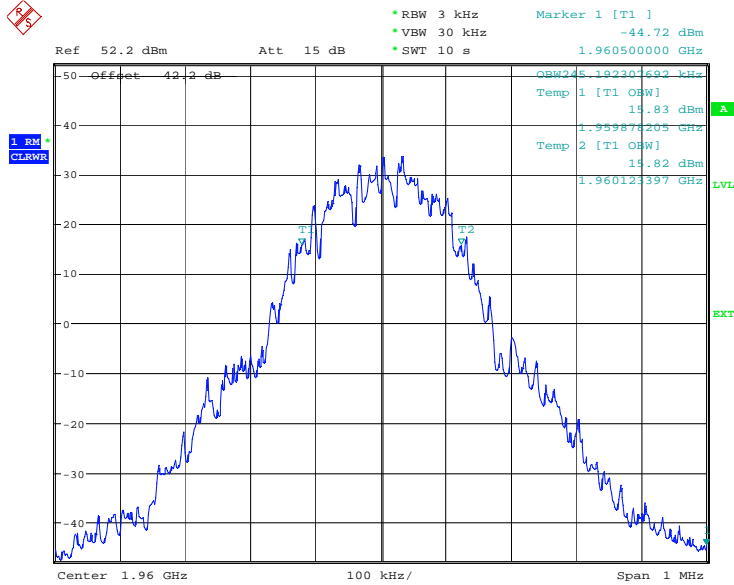

Date: 21.MAR.2011 09:22:23



Product Service

### 8-PSK

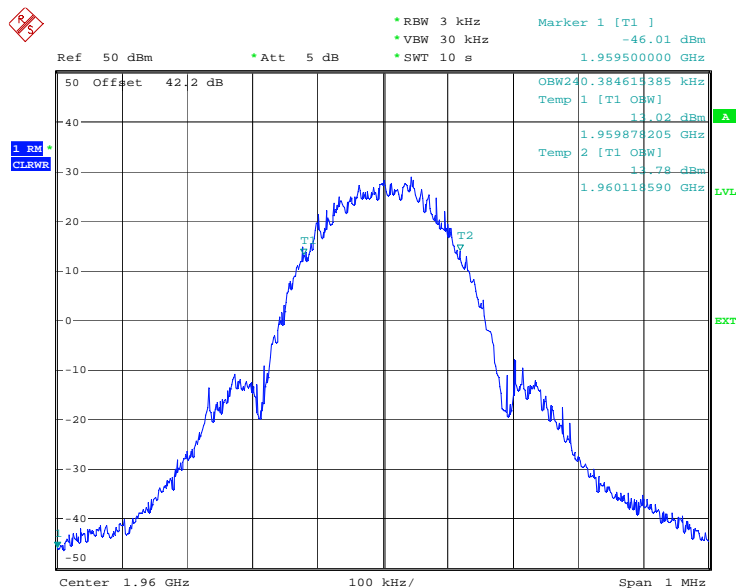

Date: 21.MAR.2011 09:59:54

### 16QAM

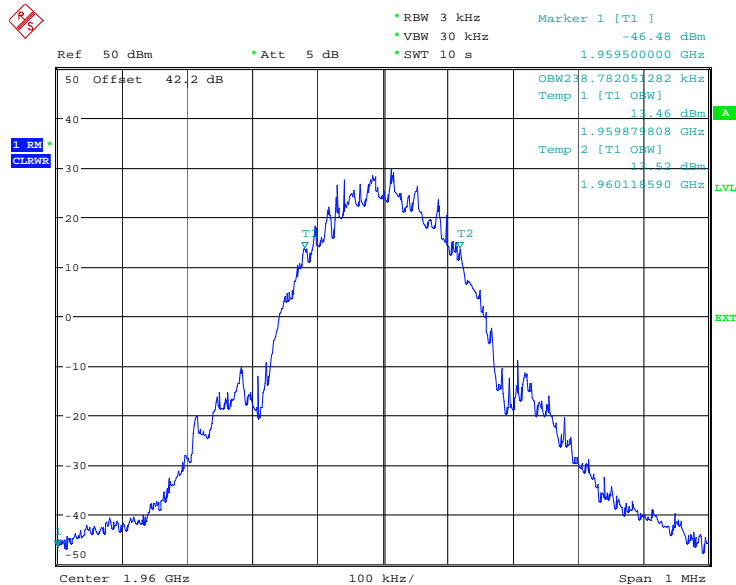

Date: 21.MAR.2011 13:11:40



**32QAM**

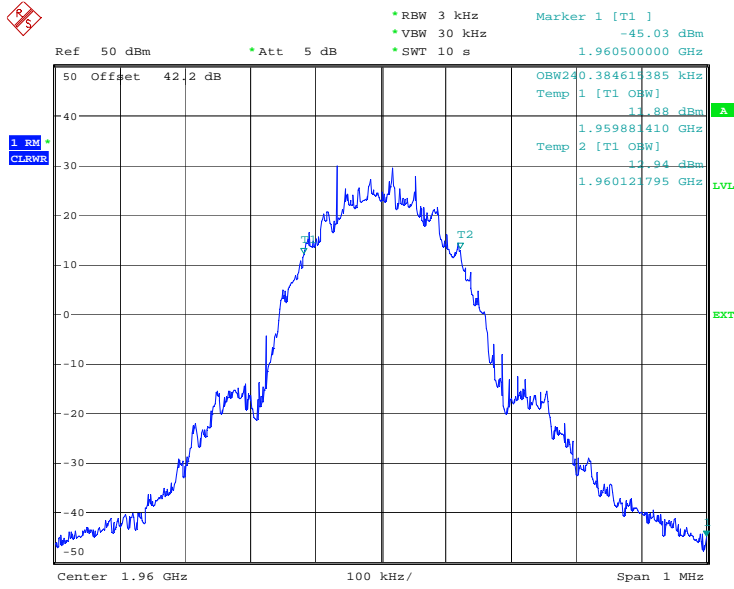

Date: 21.MAR.2011 13:23:13

**Configuration 1 - Mode 3**

**GMSK**

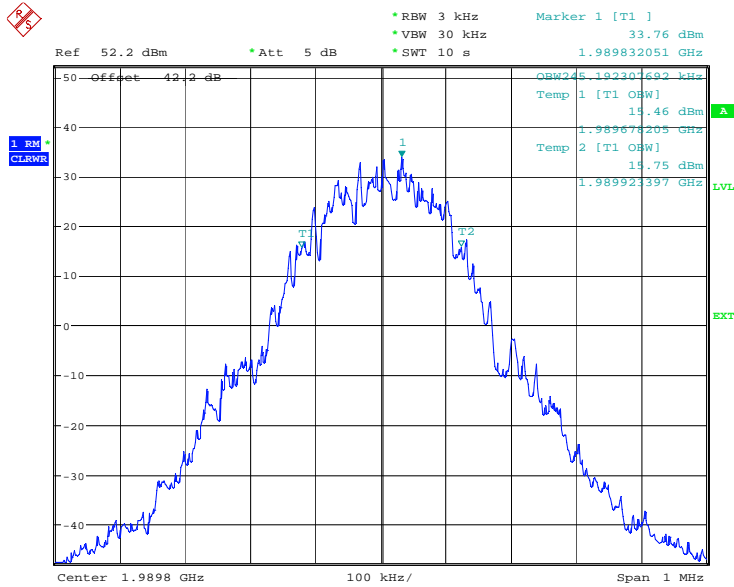

Date: 21.MAR.2011 09:30:21



### 8-PSK

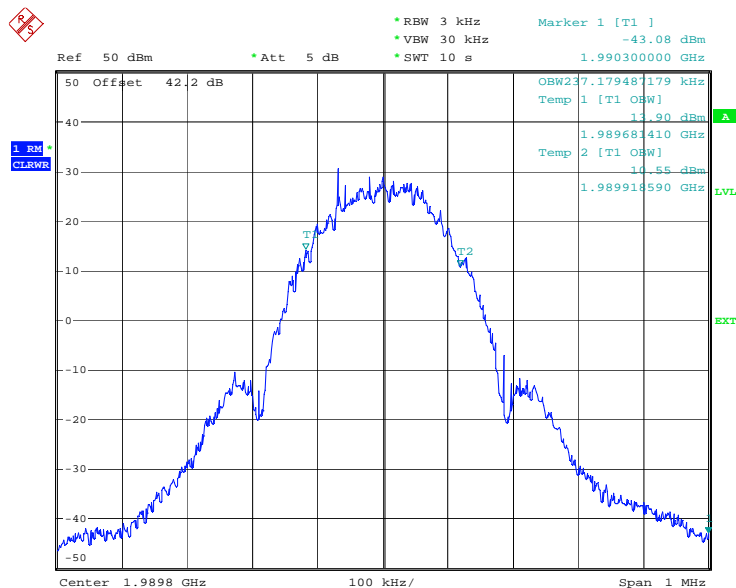

Date: 21.MAR.2011 10:11:29

### 16QAM

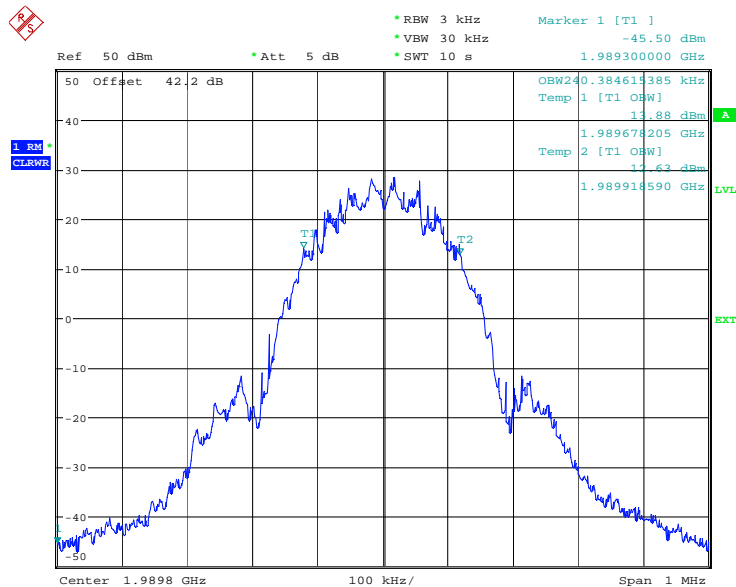

Date: 21.MAR.2011 13:14:10



Product Service

32QAM

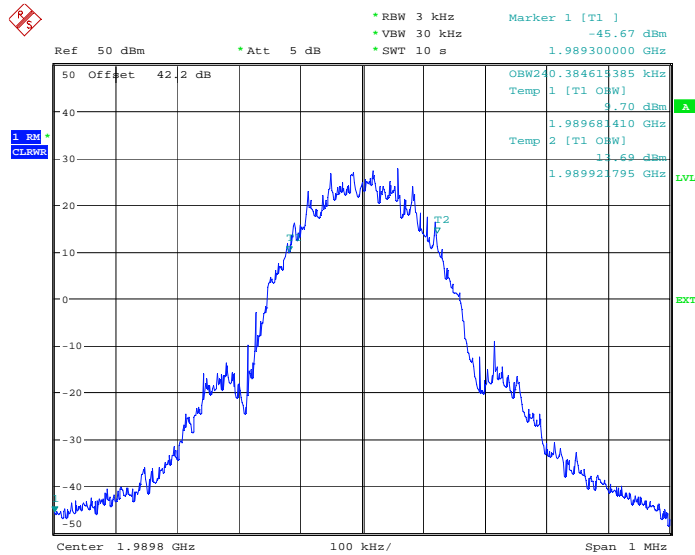

Date: 21.MAR.2011 13:20:18

-26dBc Bandwidth

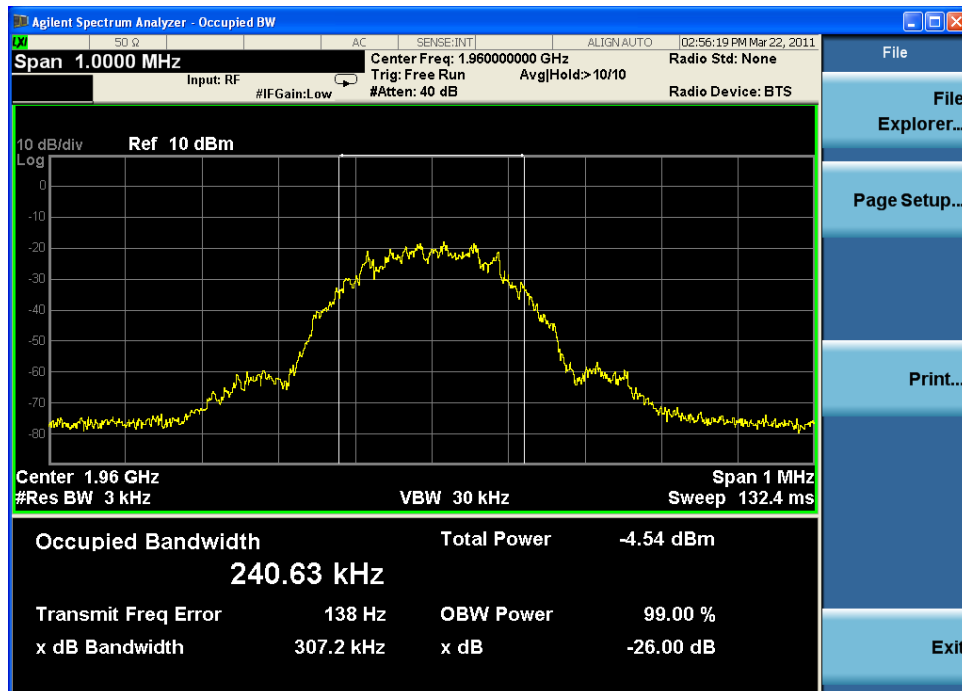



Product Service

## 2.5 SPURIOUS EMISSIONS AT ANTENNA TERMINALS ( $\pm 1$ MHz)

### 2.5.1 Specification Reference

FCC CFR 47 Part 2, Clause 2.1051  
 FCC CFR 47 Part 24, Clause 24.238 (b)  
 Industry Canada RSS-133 Clause 6.5

### 2.5.2 Equipment Under Test

RUG 11 B2 / KRC 161 198/1, S/N: CB4G584762

### 2.5.3 Date of Test and Modification State

21 and 22 March 2011 – Modification State 0

### 2.5.4 Test Equipment Used

The major items of test equipment used for the above tests are identified in Section 3.1.

### 2.5.5 Test Method and Operating Modes

The test was applied in accordance with the test method requirements of FCC CFR 47 Part 2 and Part 24 and Industry Canada RSS-133.

In accordance with 24.238(b), at least 1% of the 26dB bandwidth was used for the resolution bandwidth up to 1 MHz away from the block edge. A resolution bandwidth of 50kHz was used between 1MHz to 5MHz away from the band edge. As the FCC rules specify a RBW of 1MHz for measurements of emissions > 1MHz away from the band edges, the limit was adjusted with -13dB to -26dBm to compensate for the reduced measurement bandwidth. Spectrum analyser detector was set as RMS.

The path loss measured and entered as a reference level offset.

The EUT was tested at its maximum power level with all timeslots active.

The test was performed with the EUT in the following configurations and modes of operation:

Configuration 1 - Mode 4  
                           - Mode 5  
 Configuration 2 - Mode 4  
                           - Mode 5  
 Configuration 3 - Mode 4  
                           - Mode 5

### 2.5.6 Environmental Conditions

	21 March 2011	22 March 2011
Ambient Temperature	24.3°C	26.2°C
Relative Humidity	24.5%	20.4%



Product Service

**2.5.7 Test Results**

For the period of test the EUT met the requirements of FCC CFR 47 Part 2 and Part 24 and Industry Canada RSS-133 for Spurious Emissions Antenna Terminals ( $\pm 1$ MHz)

Below are the Frequencies the EUT was tested against along with the tested channels.

Remark:

The channel adjacent to the lower and higher band-edge cannot be used. The lowest usable channel is 513 (1930.4MHz), the highest usable channel is 809 (1989.6MHz)

**Configuration 1 - Mode 4 and 5**

Band Edge Frequency	Edge Test with GMSK modulation Channel No./Frequencies	Edge Test with 8-PSK modulation Channel No./Frequencies	Edge Test with 16QAM modulation Channel No./Frequencies	Edge Test with 32QAM modulation Channel No./Frequencies
Bottom 1930 MHz	Channel: 513 Frequency: 1930.4 MHz	Channel: 513 Frequency: 1930.4 MHz	Channel: 513 Frequency: 1930.4 MHz	Channel: 513 Frequency: 1930.4 MHz
Top 1990 MHz	Channel: 809 Frequency: 1989.6 MHz	Channel: 809 Frequency: 1989.6 MHz	Channel: 809 Frequency: 1989.6 MHz	Channel: 809 Frequency: 1989.6 MHz

**Configuration 2 - Mode 4 and 5**

Band Edge Frequency	Edge Test with GMSK modulation Channel No./Frequencies	Edge Test with 8-PSK modulation Channel No./Frequencies	Edge Test with 16QAM modulation Channel No./Frequencies	Edge Test with 32QAM modulation Channel No./Frequencies
Bottom 1930 MHz	Channel: 513 Frequency: 1930.4 MHz	Channel: 513 Frequency: 1930.4 MHz	Channel: 513 Frequency: 1930.4 MHz	Channel: 513 Frequency: 1930.4 MHz
Top 1990 MHz	Channel: 809 Frequency: 1989.6 MHz	Channel: 809 Frequency: 1989.6 MHz	Channel: 809 Frequency: 1989.6 MHz	Channel: 809 Frequency: 1989.6 MHz

**Configuration 3 - Mode 4 and 5**

Band Edge Frequency	Edge Test with GMSK modulation Channel No./Frequencies	Edge Test with 8-PSK modulation Channel No./Frequencies	Edge Test with 16QAM modulation Channel No./Frequencies	Edge Test with 32QAM modulation Channel No./Frequencies
Bottom 1930 MHz	Channel: 513 Frequency: 1930.4 MHz	Channel: 513 Frequency: 1930.4 MHz	Channel: 513 Frequency: 1930.4 MHz	Channel: 513 Frequency: 1930.4 MHz
Top 1990 MHz	Channel: 809 Frequency: 1989.6 MHz	Channel: 809 Frequency: 1989.6 MHz	Channel: 809 Frequency: 1989.6 MHz	Channel: 809 Frequency: 1989.6 MHz

The channels shown in the table above are the minimum and maximum channels that can be used in the authorised frequency ranges to maintain compliance. Channels used outside of those stated and power levels used beyond those stated in the table exceed the specification limits, thus they cannot be used.

The channels outside of those shown in the table above were not tested at lower power levels to determine a level at which compliance would be achieved. Therefore, to maintain compliance, only the channels shown in the table above shall be used.





Product Service

The test results are shown below

**Configuration 1 - Mode 4**

**GMSK**



Date: 21.MAR.2011 14:54:50

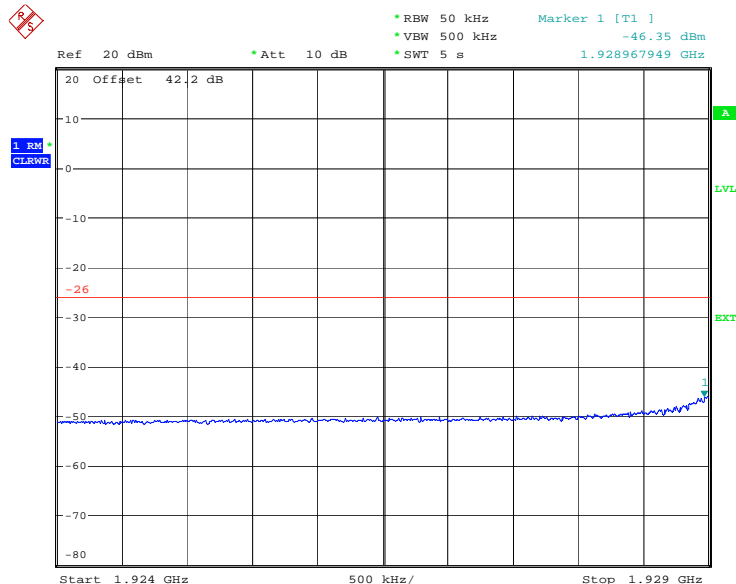

Date: 21.MAR.2011 14:49:51



Product Service

8-PSK

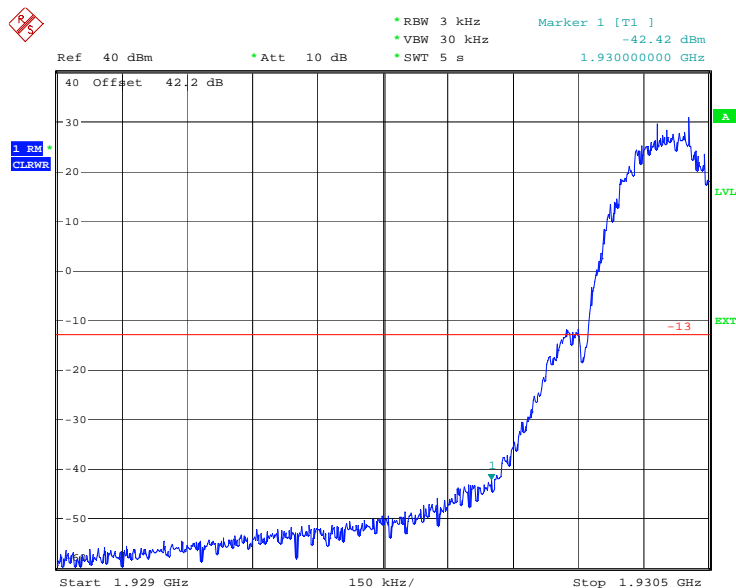

Date: 21.MAR.2011 14:41:32

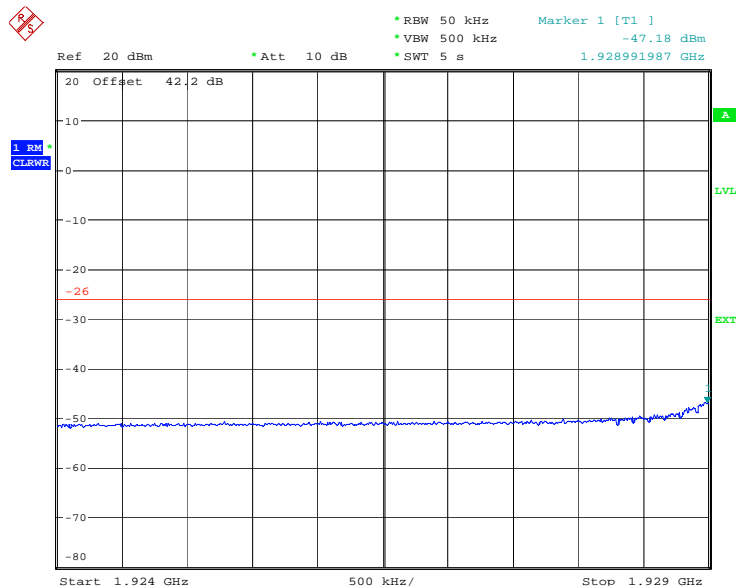

Date: 21.MAR.2011 14:44:01



16QAM

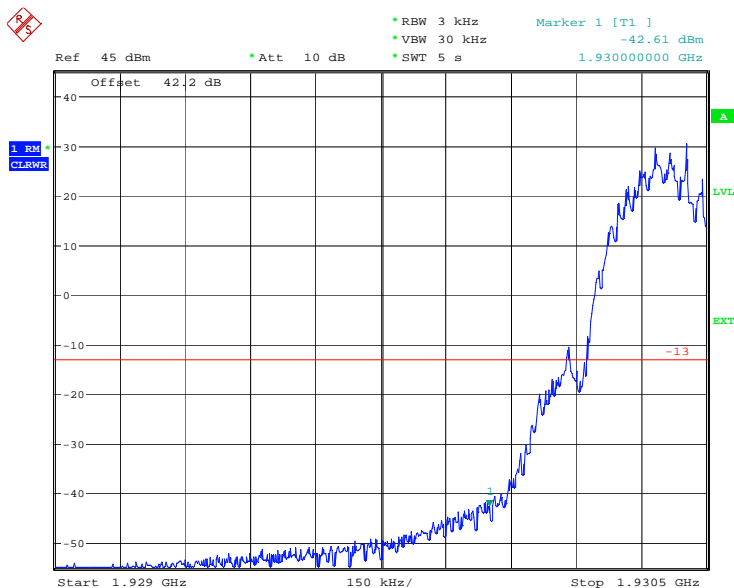

Date: 21.MAR.2011 14:39:04

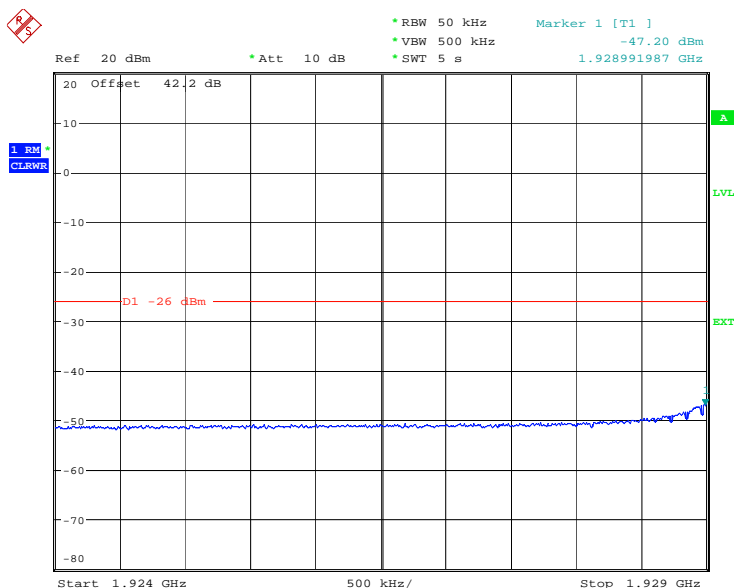

Date: 21.MAR.2011 14:33:08



Product Service

32QAM



Date: 21.MAR.2011 14:18:00

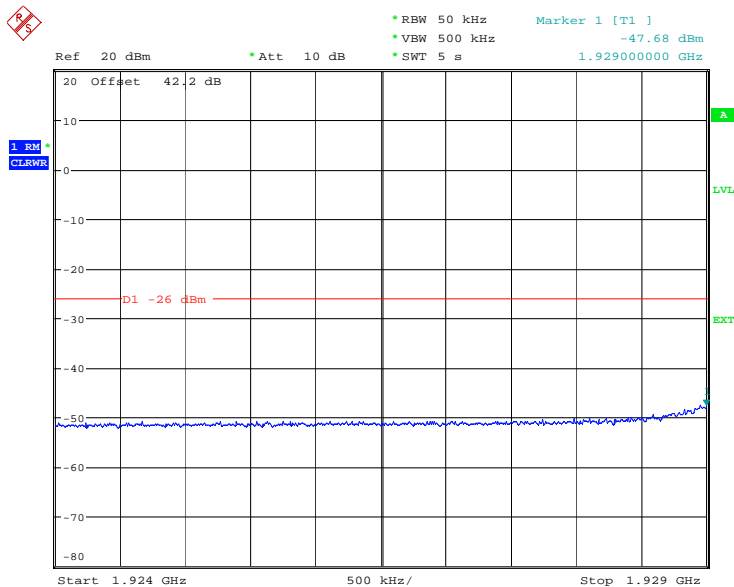

Date: 21.MAR.2011 14:20:29



**Configuration 1 - Mode 5**

**GMSK**

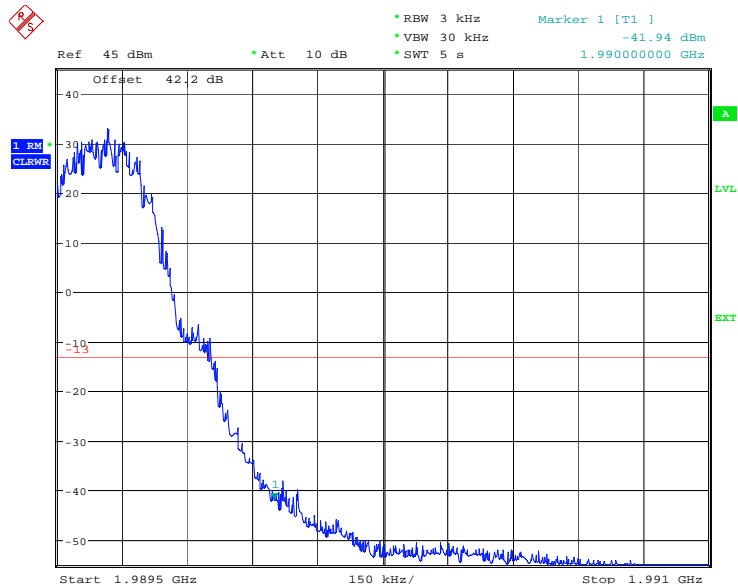

Date: 21.MAR.2011 14:47:50

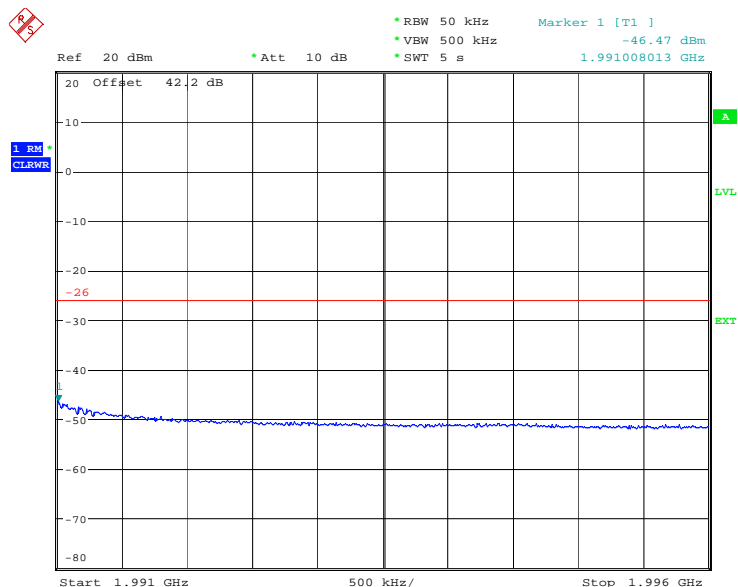

Date: 21.MAR.2011 14:48:46



8-PSK

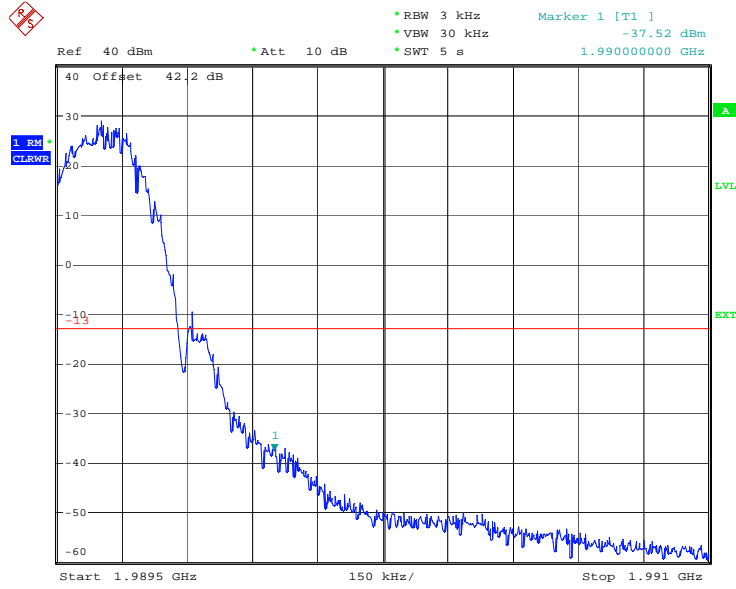

Date: 21.MAR.2011 14:46:23

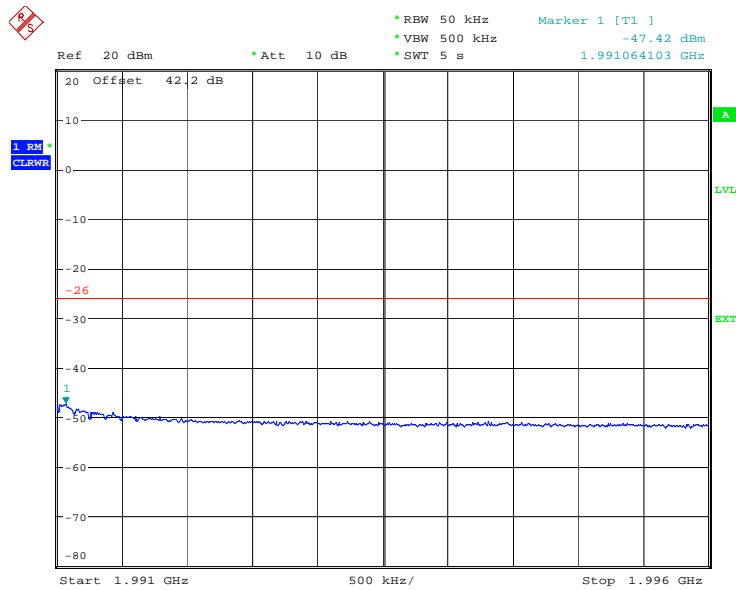

Date: 21.MAR.2011 14:45:12



16QAM



Date: 21.MAR.2011 14:29:17

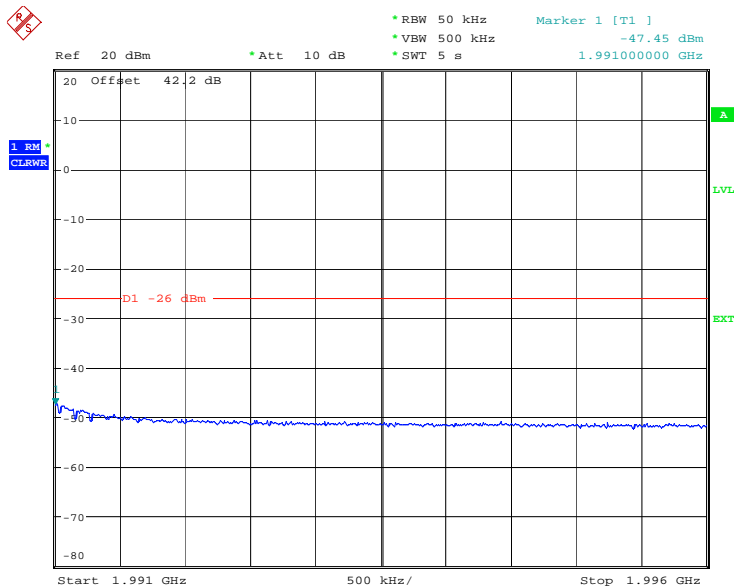

Date: 21.MAR.2011 14:30:55



Product Service

32QAM

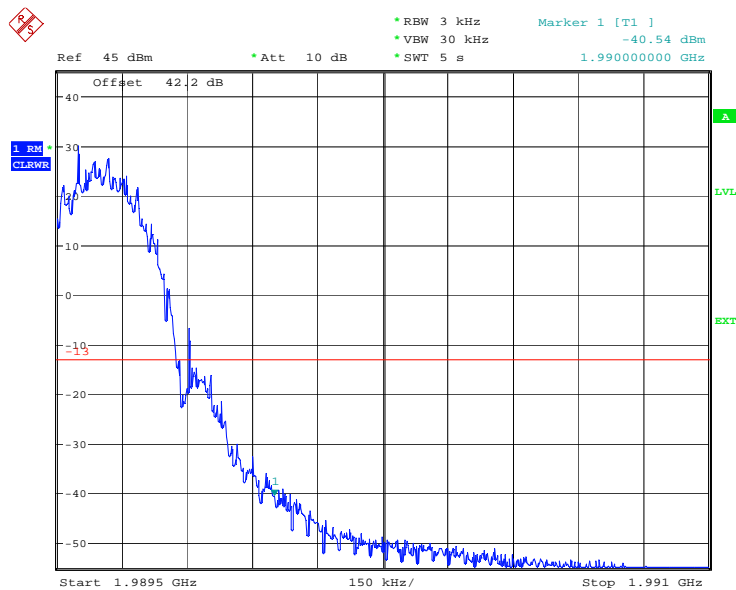

Date: 21.MAR.2011 14:27:26

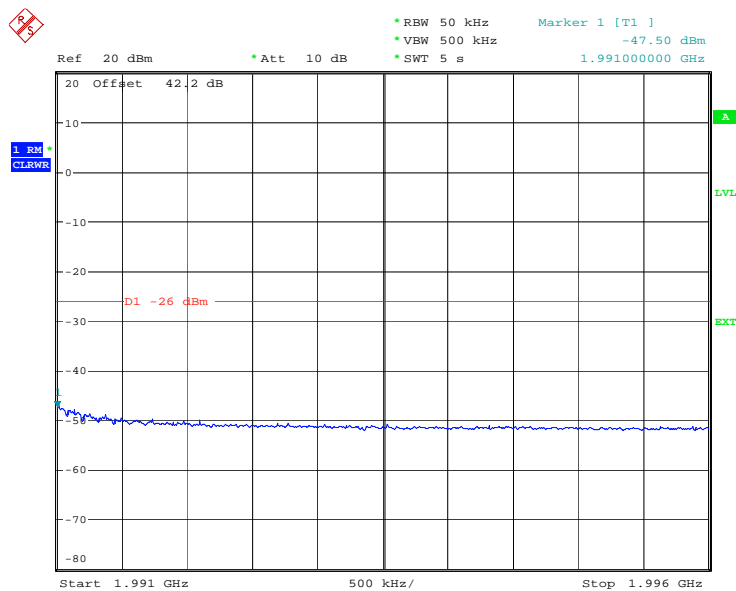

Date: 21.MAR.2011 14:22:52





**Configuration 2 - Mode 4**

**GMSK**

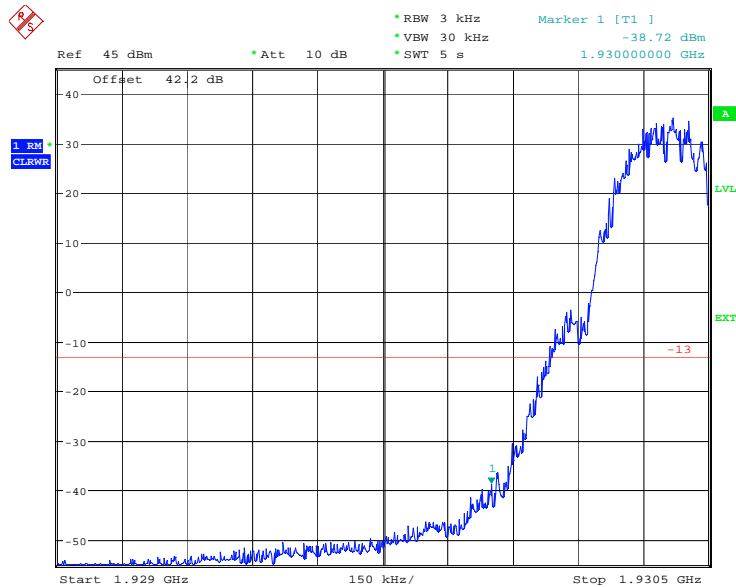

Date: 21.MAR.2011 15:06:43

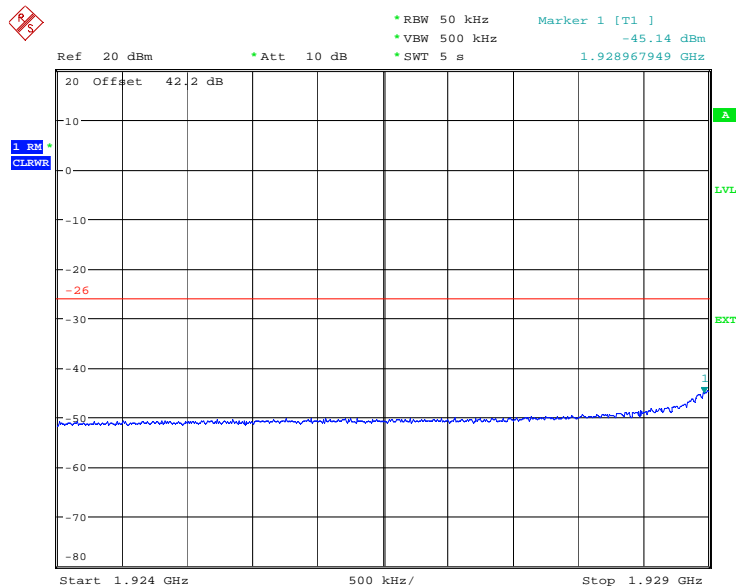

Date: 21.MAR.2011 15:07:48



Product Service

8-PSK

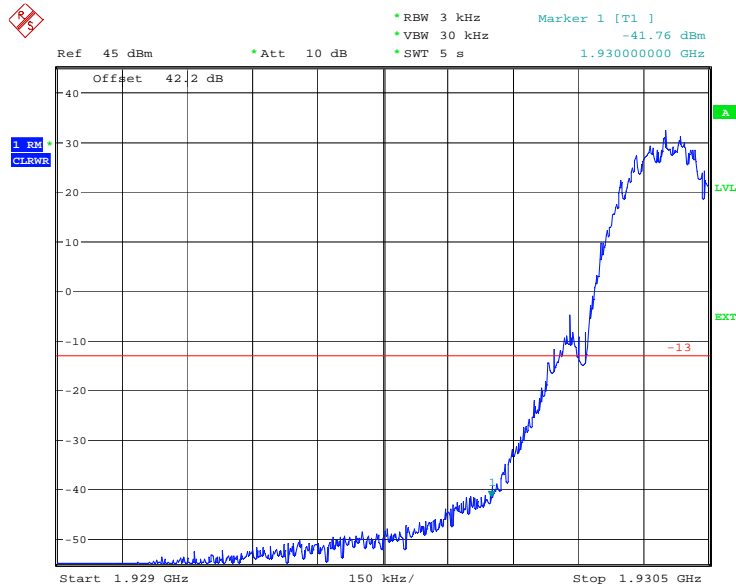

Date: 21.MAR.2011 15:16:48

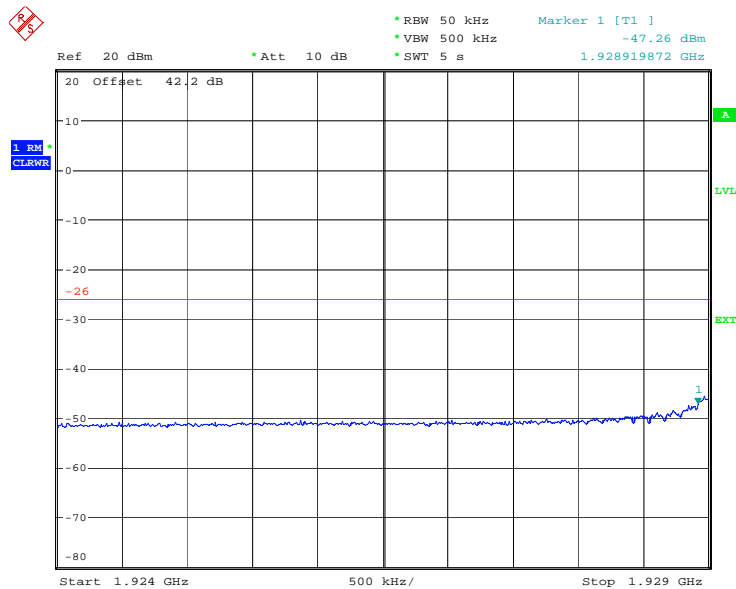

Date: 21.MAR.2011 15:13:56



16QAM

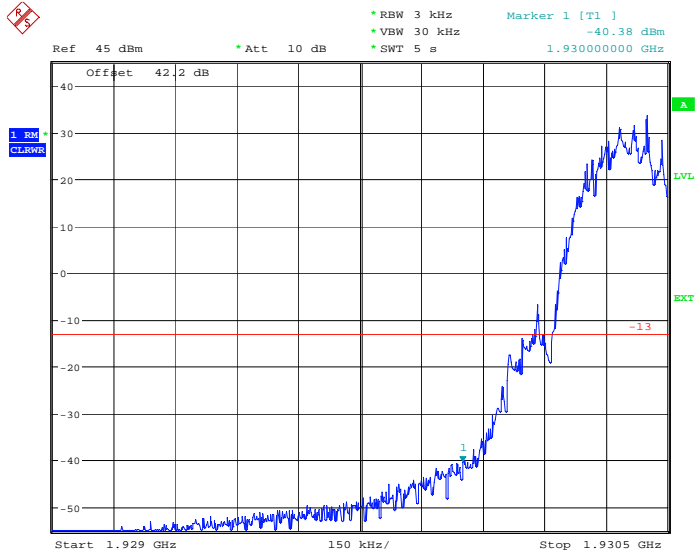

Date: 21.MAR.2011 15:17:44

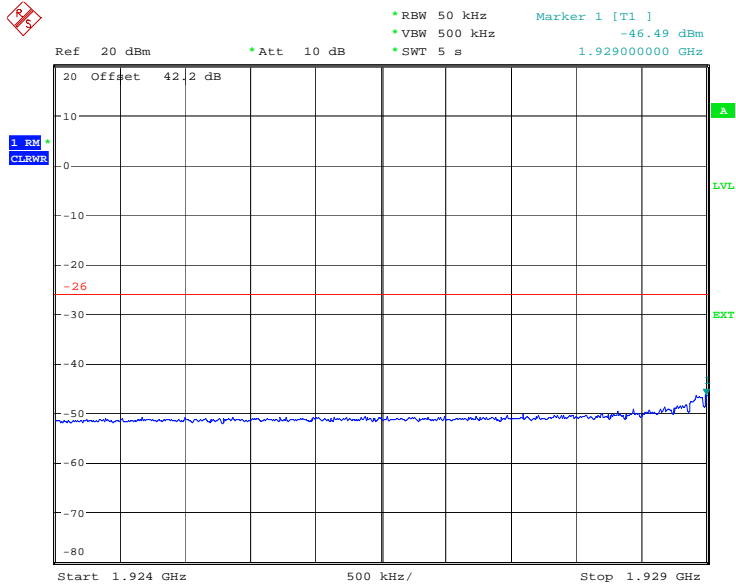

Date: 21.MAR.2011 15:19:15



32QAM

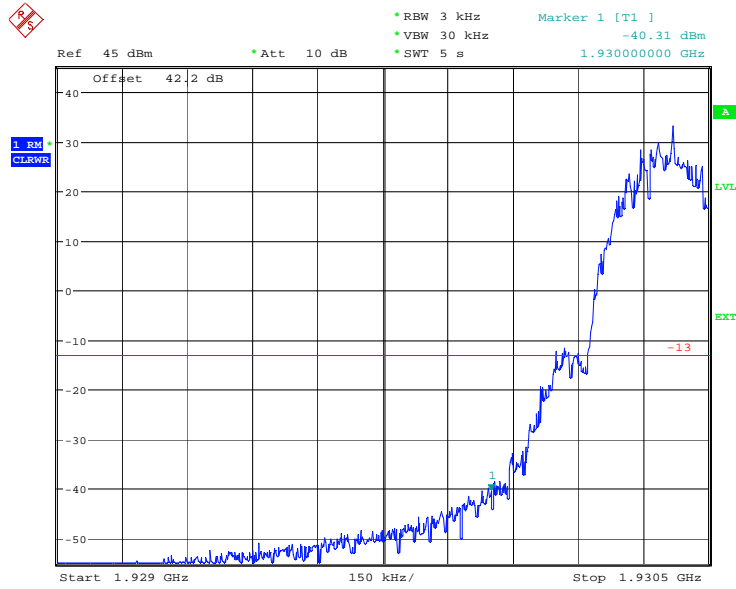

Date: 21.MAR.2011 15:27:50

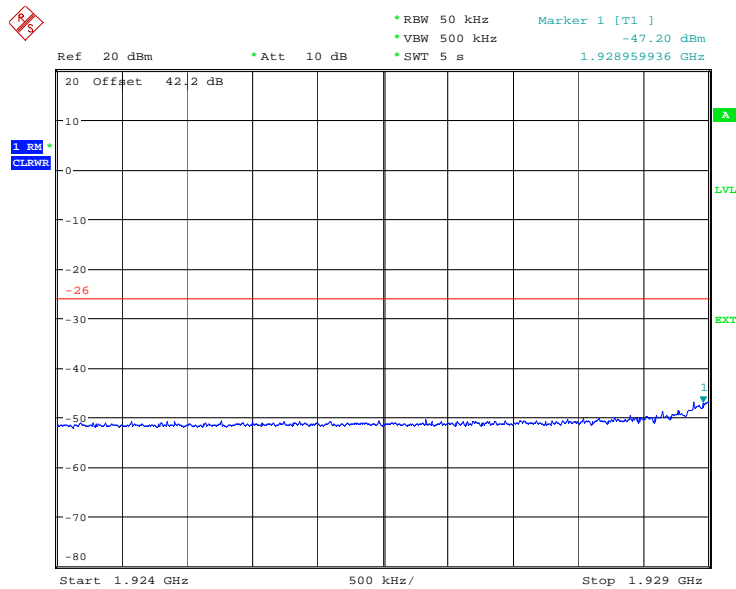

Date: 21.MAR.2011 15:26:44



Product Service

**Configuration 2 - Mode 5**

**GMSK**

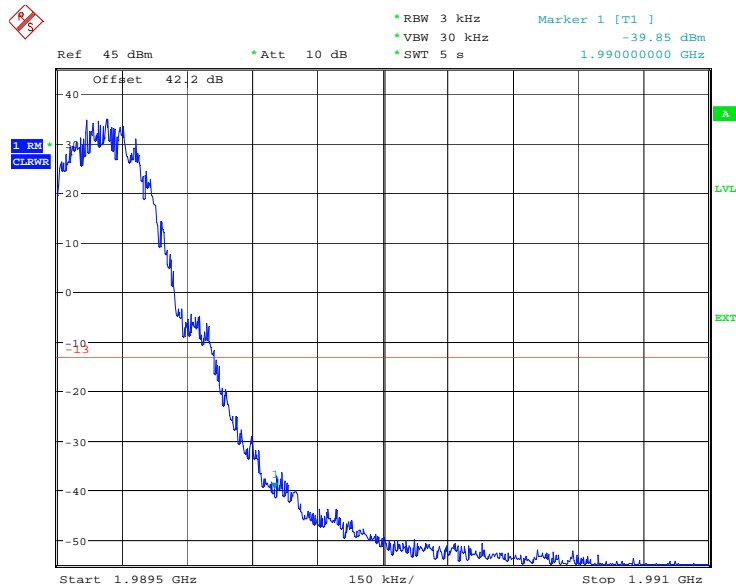

Date: 21.MAR.2011 15:11:17

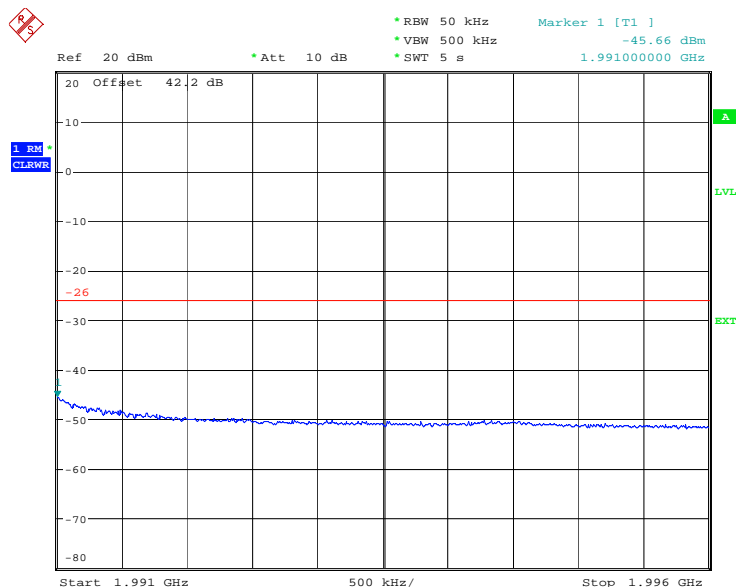

Date: 21.MAR.2011 15:10:07



Product Service

### 8-PSK

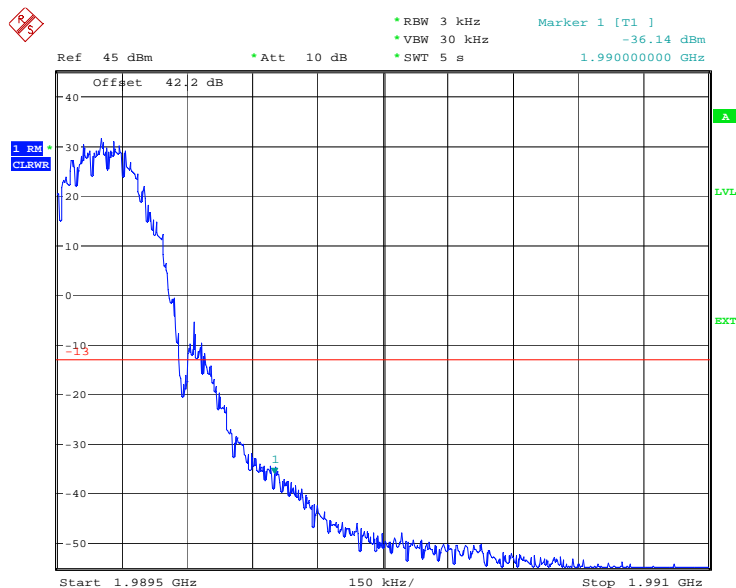

Date: 21.MAR.2011 15:12:16

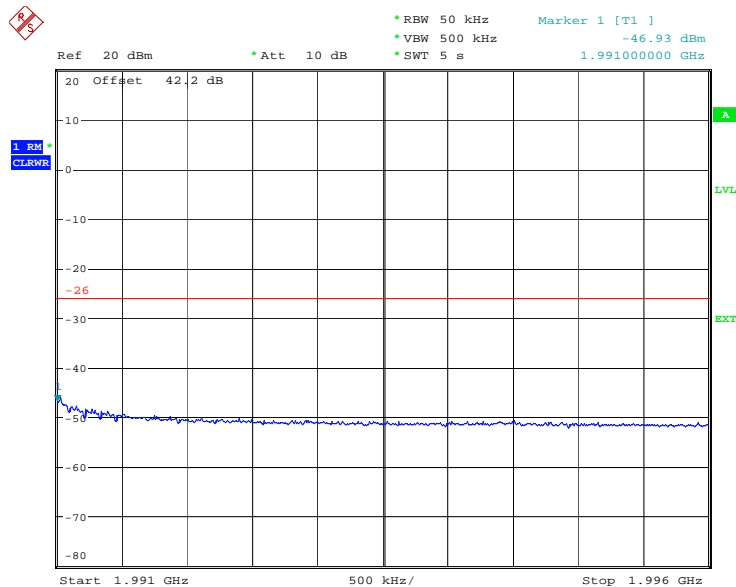

Date: 21.MAR.2011 15:13:00



16QAM

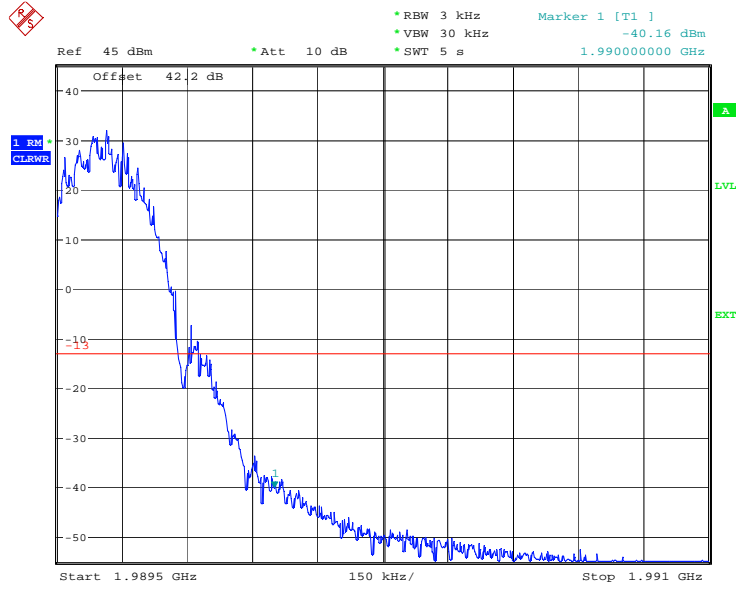

Date: 21.MAR.2011 15:21:25

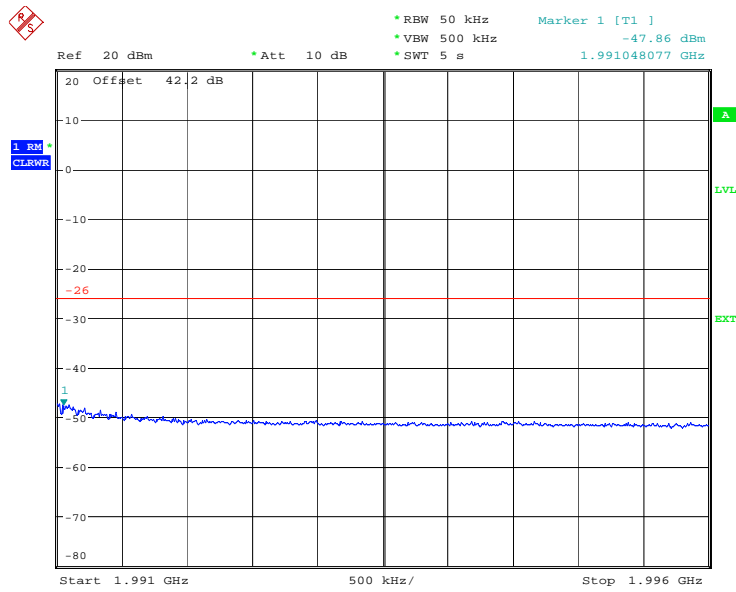

Date: 21.MAR.2011 15:20:15



32QAM



Date: 21.MAR.2011 15:22:11

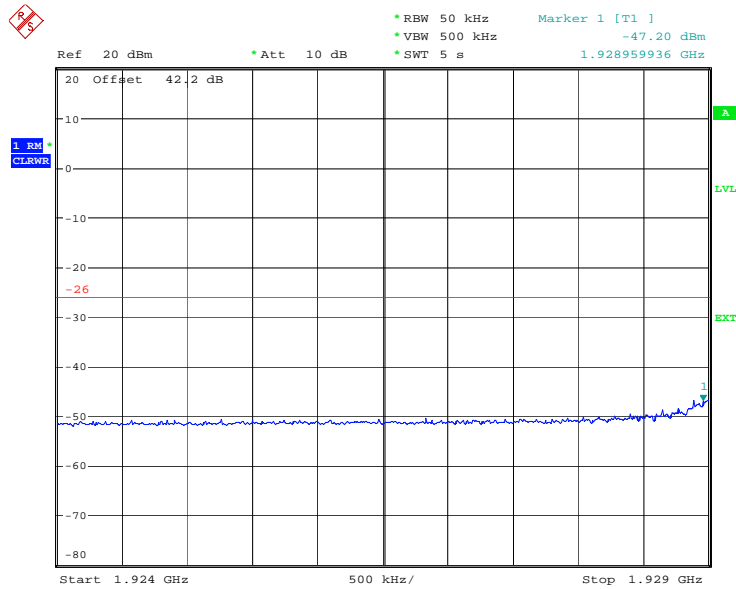

Date: 21.MAR.2011 15:26:44





**Configuration 3 - Mode 4**

**GMSK**

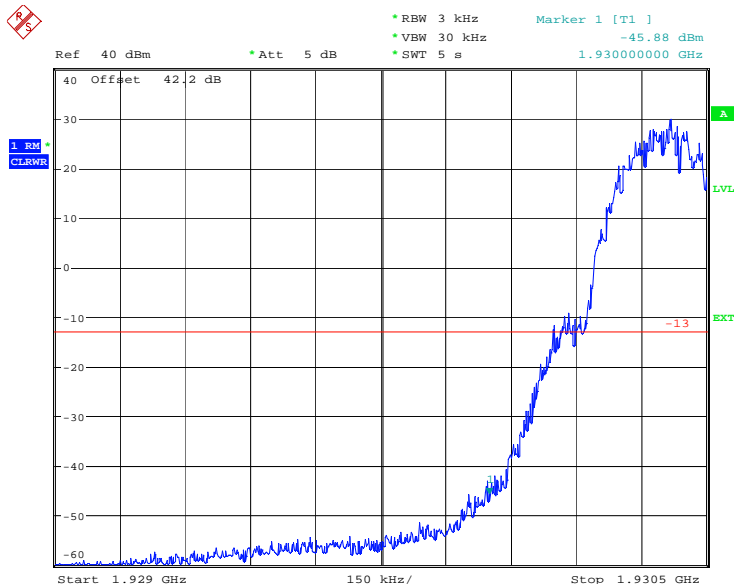

Date: 22.MAR.2011 09:49:59

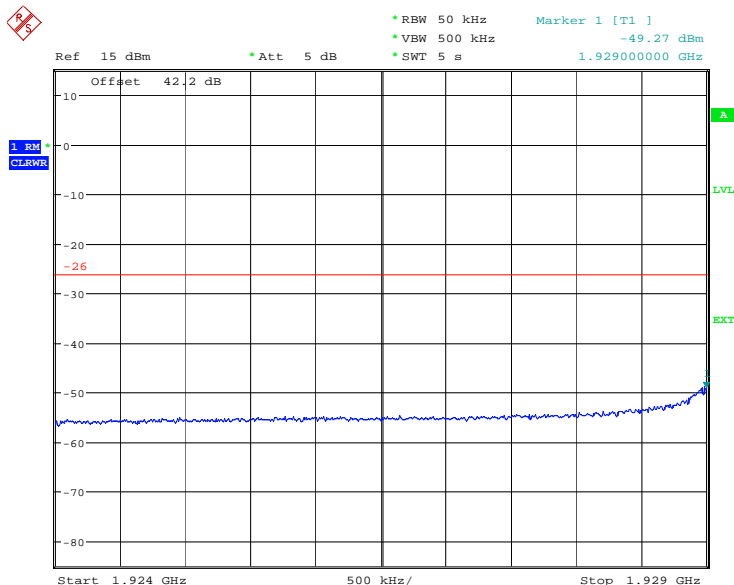

Date: 22.MAR.2011 09:58:11



Product Service

8-PSK

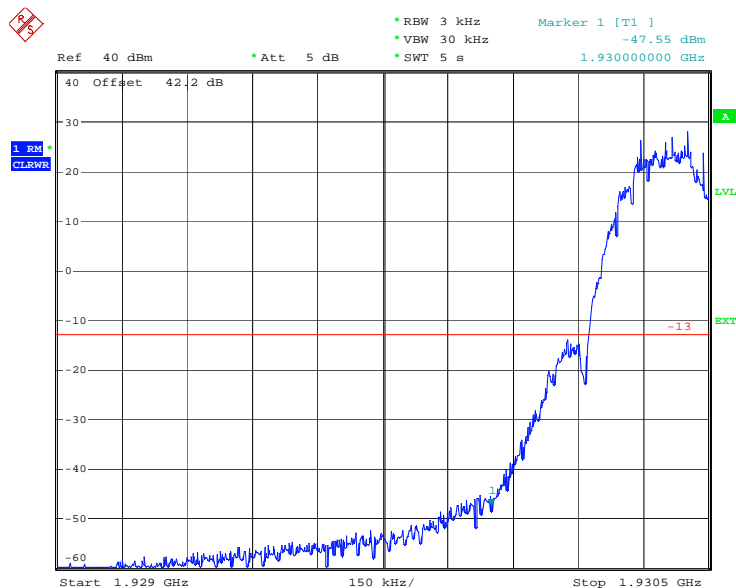

Date: 22.MAR.2011 09:49:11

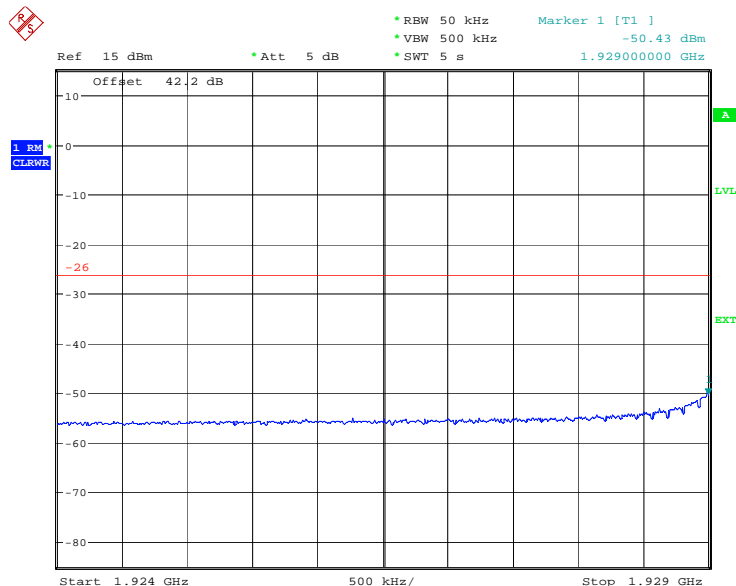

Date: 22.MAR.2011 09:58:46



16QAM

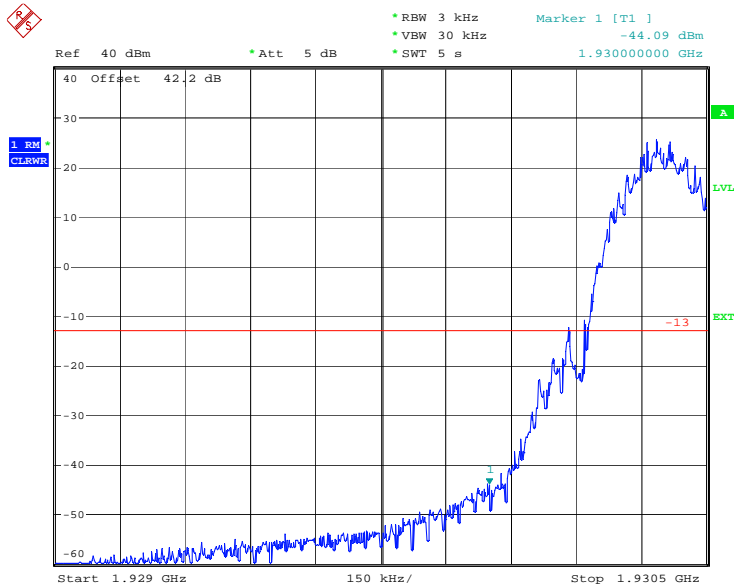

Date: 22.MAR.2011 09:48:37

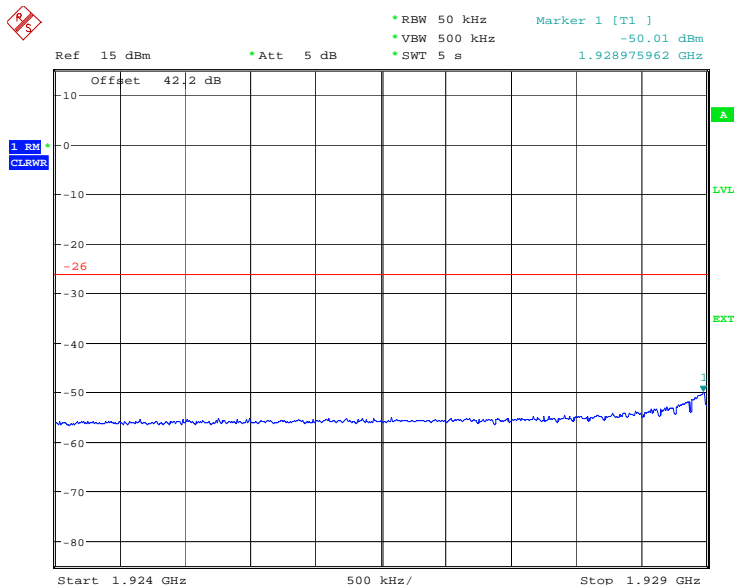

Date: 22.MAR.2011 09:59:12



Product Service

32QAM

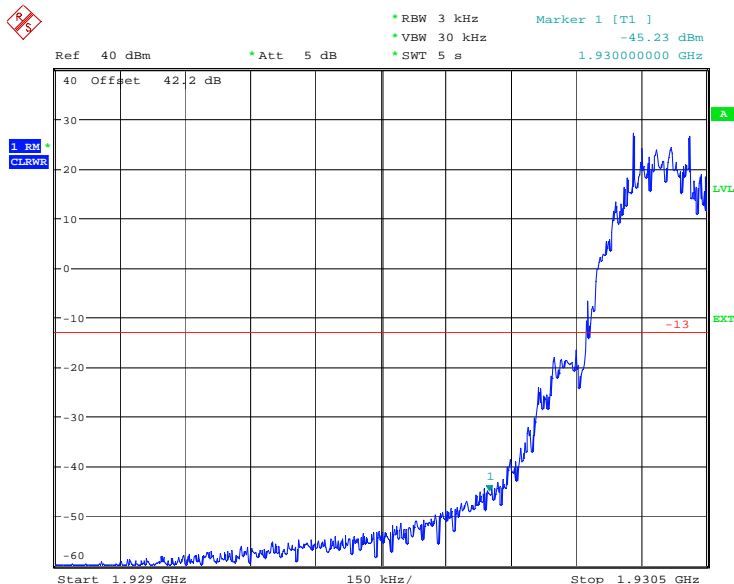

Date: 22.MAR.2011 09:47:43

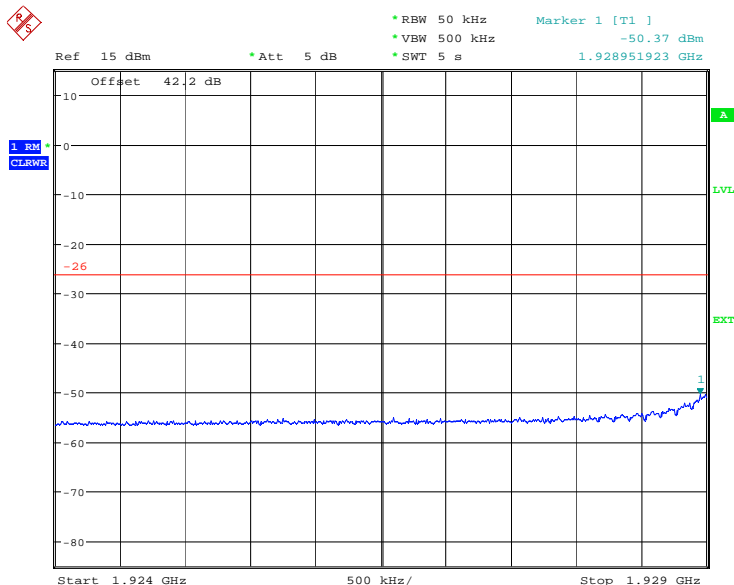

Date: 22.MAR.2011 09:59:41



Product Service

**Configuration 3 - Mode 5**

**GMSK**

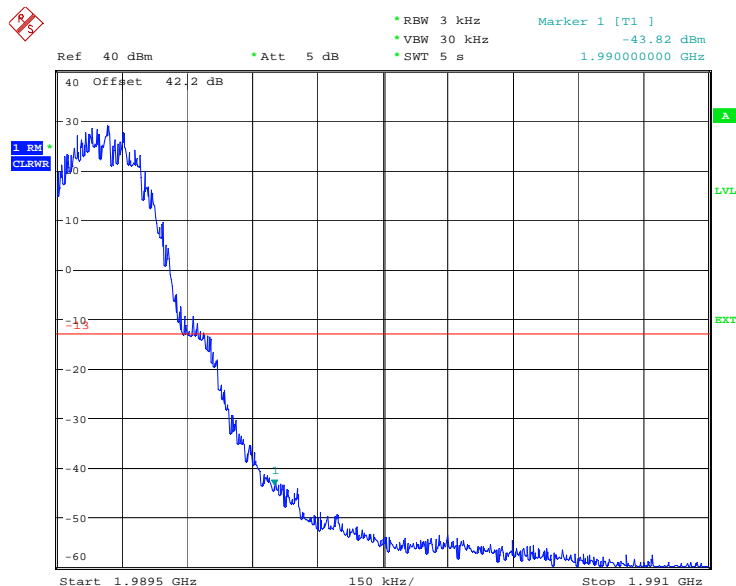

Date: 22.MAR.2011 09:51:44

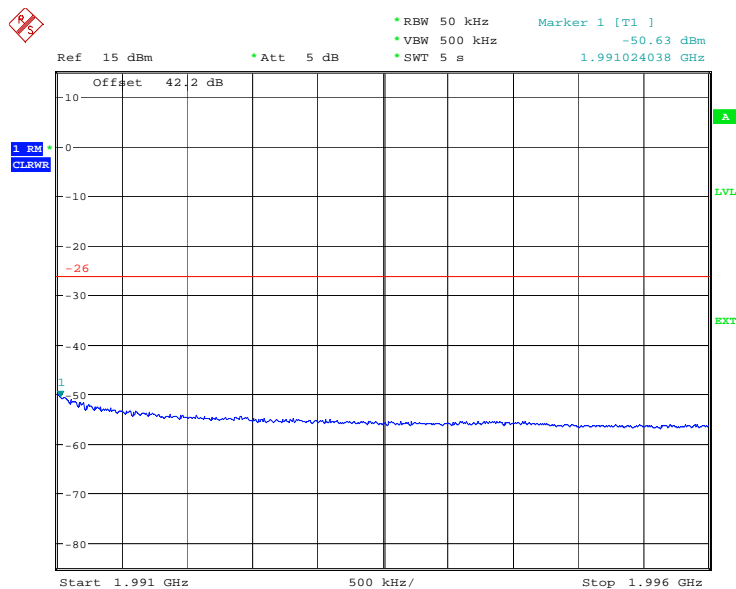

Date: 22.MAR.2011 09:57:27



### 8-PSK

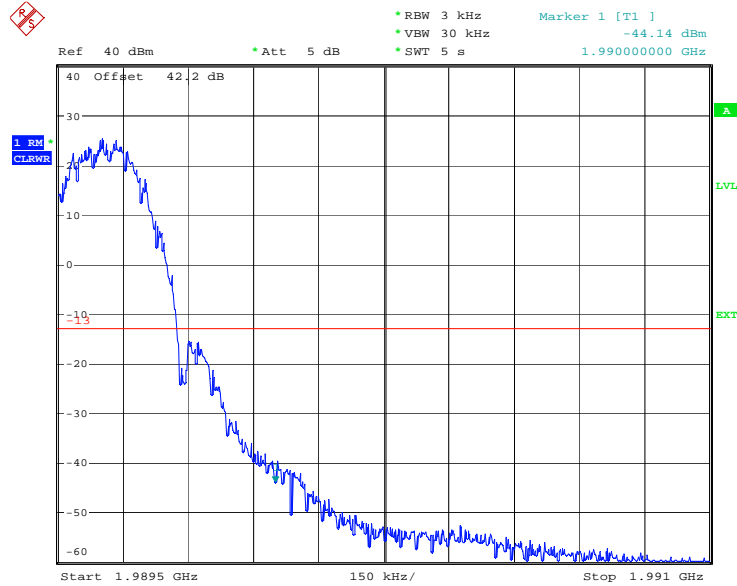

Date: 22.MAR.2011 09:52:39

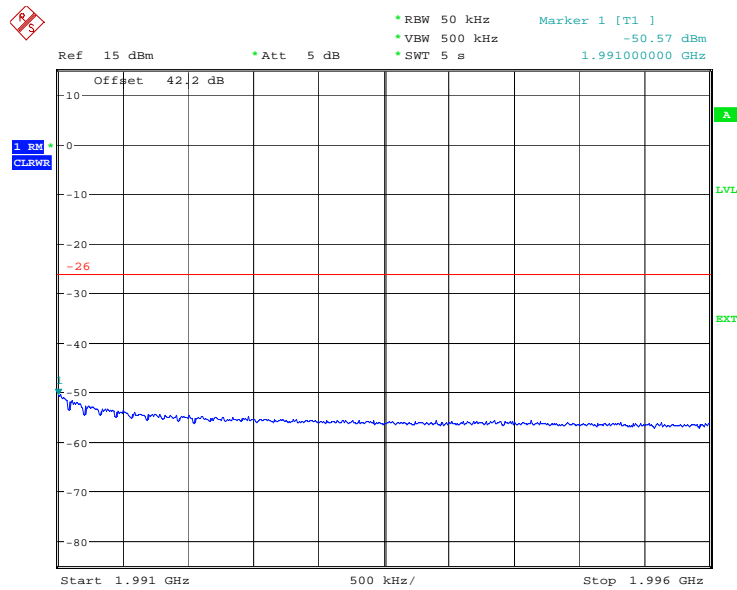

Date: 22.MAR.2011 09:56:53



16QAM

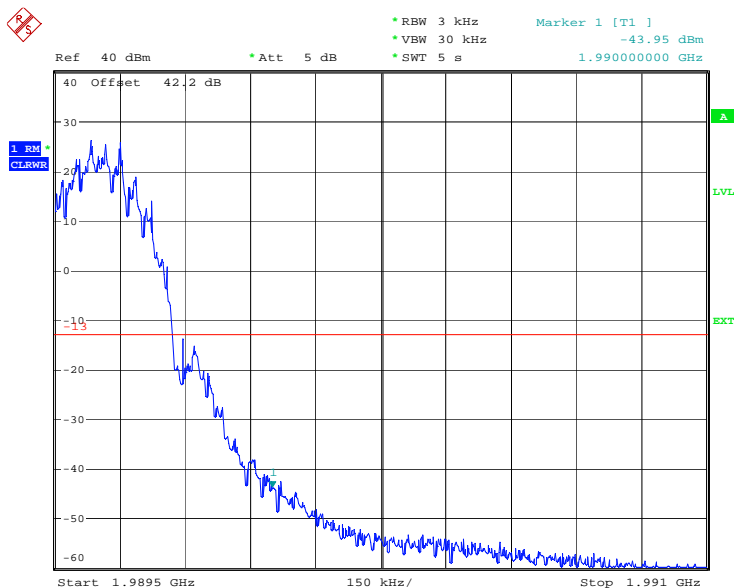

Date: 22.MAR.2011 09:53:14

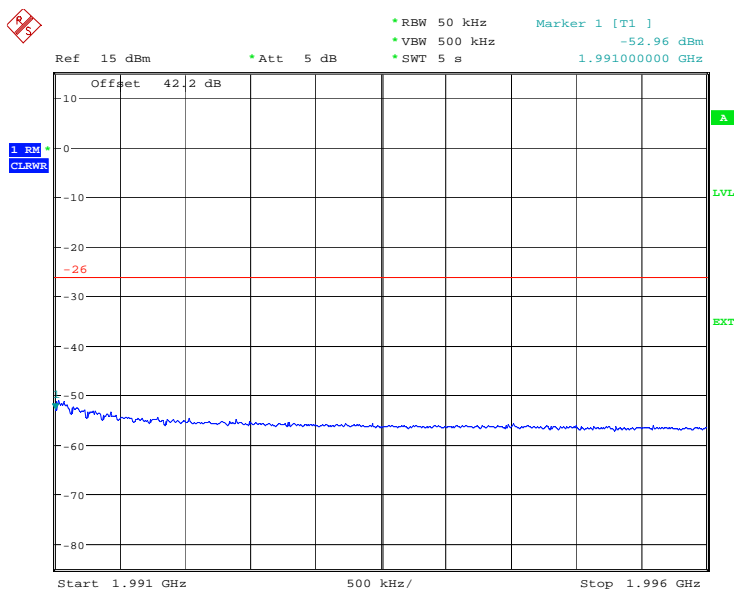

Date: 22.MAR.2011 09:56:16



Product Service

32QAM

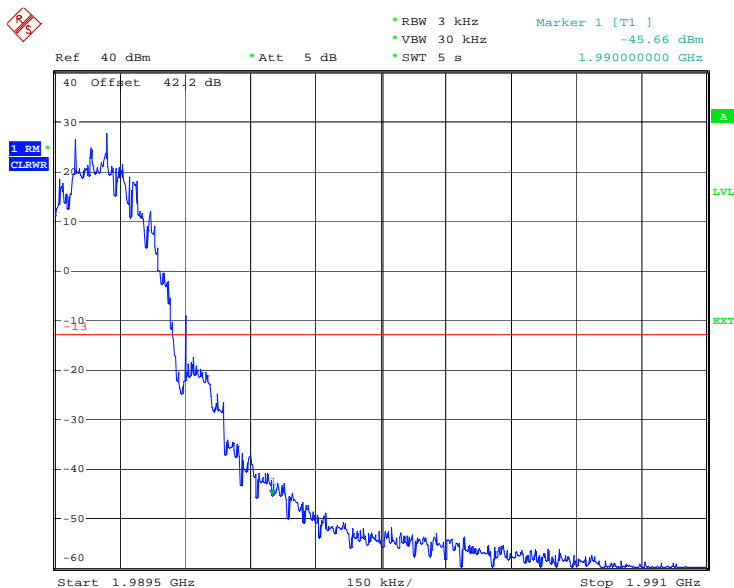

Date: 22.MAR.2011 09:53:53

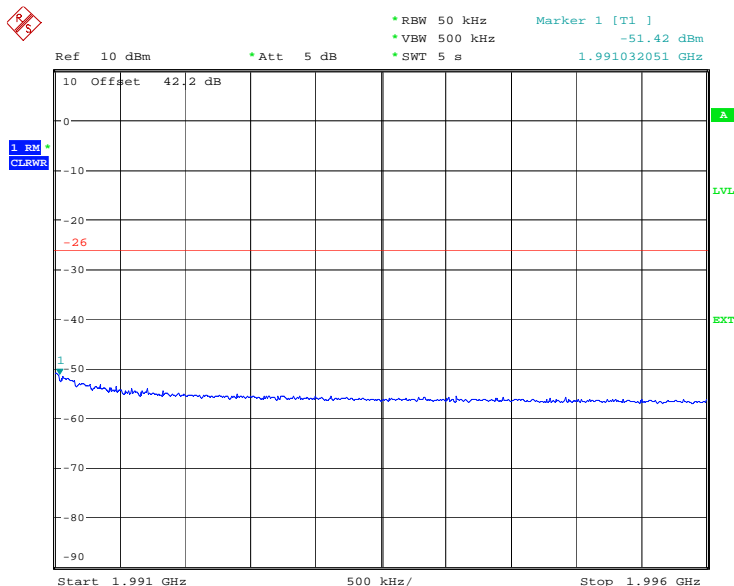

Date: 22.MAR.2011 09:55:25

Limit

The power of any emission outside the frequency band shall be attenuated below the transmitter power (P) by at least  $43 + 10\log P$  dB.





## 2.6 RADIATED SPURIOUS EMISSIONS

### 2.6.1 Specification Reference

FCC CFR 47 Part 2, Clause 2.1053  
FCC CFR 47 Part 24, 24.238 (a)  
Industry Canada RSS-133, Clause 6.5

### 2.6.2 Equipment Under Test

RUG 11 B2 / KRC 161 198/1, S/N: CB4G584762

### 2.6.3 Date of Test and Modification State

25 March, 01 and 02 April 2011 – Modification State 0

### 2.6.4 Test Equipment Used

The major items of test equipment used for the above tests are identified in Section 3.1.

### 2.6.5 Test Method and Operating Modes

The test was applied in accordance with the test method requirements of FCC CFR 47 Part 2 and Part 24 and Industry Canada RSS-133.

The test object was powered with -48V DC. All measurements were performed with the test object configured for maximum transmit power. The configuration represents worst case for radiated spurious emission measurements. The configuration TCC was found to be representative for worst case for the measurements.

A preliminary profile of the Spurious Radiated Emissions was obtained by operating the EUT on a remotely controlled turntable within the chamber. Measurements of emissions from the EUT were obtained with the Measurement Antenna in both Horizontal and Vertical Polarizations.

Emissions identified within the range 30MHz - 20GHz were then formally measured using a Peak detector as the worst case.

In the frequency Range 30MHz - 20GHz, the measurement was performed with a resolution bandwidth of 1MHz.

The measurements were performed at a 3m distance unless otherwise stated.

The limits for Spurious Emissions have been calculated, as shown below using the following formula:

Field Strength of Carrier -  $(43 + 10\text{Log}(P))$  dB

Where:

Field Strength is measured in  $\text{dB}\mu\text{V}/\text{m}$

P is measured Transmitter Power in Watts



### **Determination of Spurious Emission Limit**

As the EUT does not have an integral antenna, the field strength of the carrier has been calculated assuming that the power is to be fed to a half-wave tuned dipoles as per 2.1053 (a).

$$E_{(v/m)} = (30 \times G_i \times P_o)^{0.5} / d$$

Where  $G_i$  is the antenna gain of ideal half-wave dipoles,  
 $P_o$  is the power out of the transceiver in W,  
 $d$  is the measurement distance in meter.

Therefore at 3m measurement distance the field strength using the lowest transceiver output power would be:

$$E_{(v/m)} = (30 \times 1.64 \times 60.12)^{0.5} / 3 = 18.129V/m = 145.2dB\mu V/m$$

As per 24.238(a) the spurious emission must be attenuated by  $43 + 10\log(P_o)$  dB this gives:

$$43 + 10\log(60.12) = 60.8dB$$

Therefore the limit at 3m measurement distance is:

$$145.2 - 60.8 = 84.4dB\mu V/m$$

This limit has been used to determine Pass or Fail for the harmonics measured and detailed in the following results.

The test was performed with the EUT in the following configurations and modes of operation:

Configuration 2 - Mode 1  
 - Mode 2  
 - Mode 3

### **2.6.6 Environmental Conditions**

	25 March 2011	01 April 2011	02 April 2011
Ambient Temperature	21.0°C	22.0°C	20.0°C
Relative Humidity	22.0%	22.0%	29.0%



Product Service

### 2.6.7 Test Results

For the period of test the EUT met the requirements of FCC CFR 47 Part 2 & Part 24 and Industry Canada RSS-133 for Radiated Spurious Emissions.

The test results are shown below

#### **Configuration 2 - Mode 1**

GMSK and 8-PSK and 16QAM and 32QAM

No emissions were detected within 20dB of the limit.

#### **Configuration 2 - Mode 2**

GMSK and 8-PSK and 16QAM and 32QAM

No emissions were detected within 20dB of the limit.

#### **Configuration 2 - Mode 3**

GMSK and 8-PSK

No emissions were detected within 20dB of the limit.



16QAM

30MHz – 1GHz

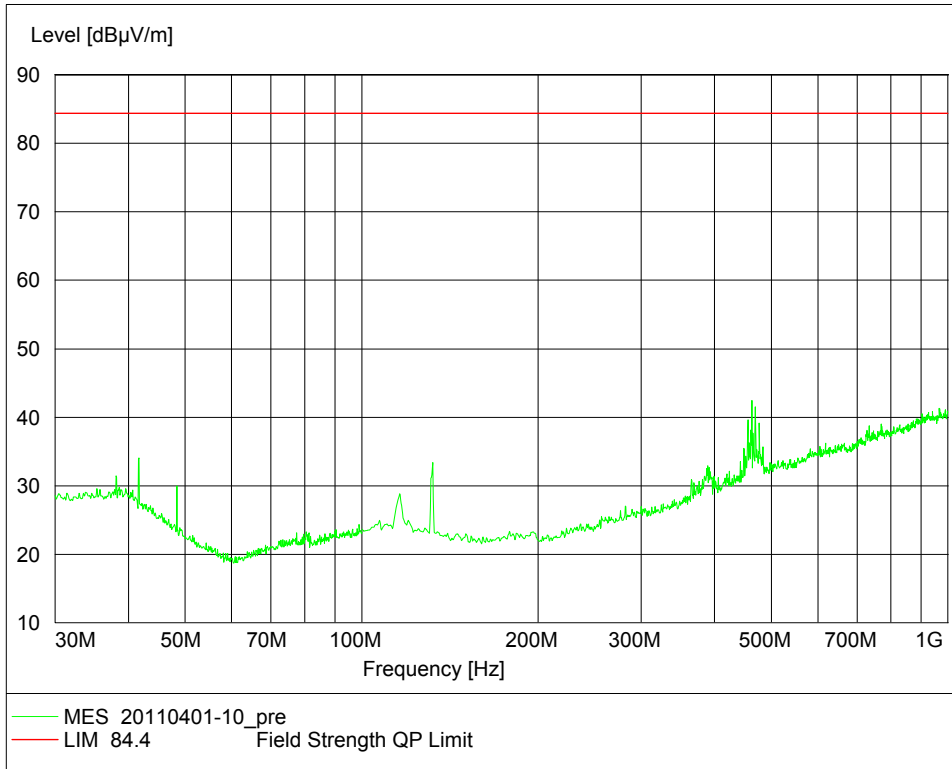

1GHz – 20GHz

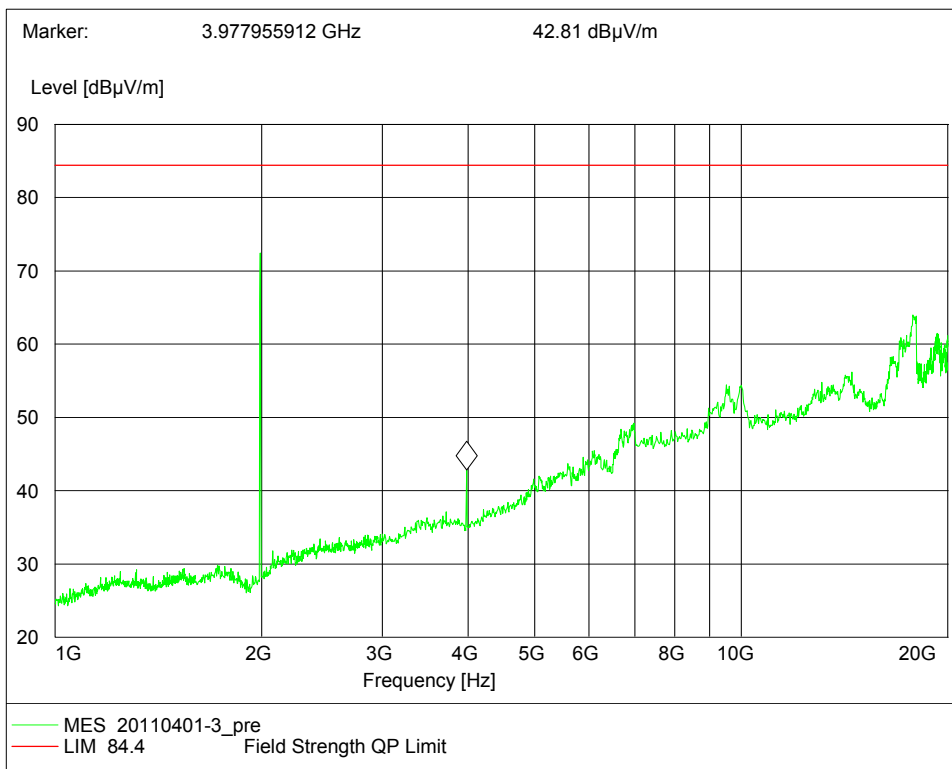



Product Service

32QAM

No emissions were detected within 20dB of the limit.

Limit	-13dBm / 84.4dB $\mu$ V/m
-------	---------------------------

Remarks

The EUT does not exceed -13dBm / 84.4dB $\mu$ V/m at the measured frequencies.



Product Service

## 2.7 CONDUCTED SPURIOUS EMISSIONS

### 2.7.1 Specification Reference

FCC CFR 47 Part 2, Clause 2.1051  
FCC CFR 47 Part 24, 24.238 (a)  
Industry Canada RSS-133, Clause 6.5

### 2.7.2 Equipment Under Test

RUG 11 B2 / KRC 161 198/1, S/N: CB4G584762

### 2.7.3 Date of Test and Modification State

21 and 22 March 2011 – Modification State 0

### 2.7.4 Test Equipment Used

The major items of test equipment used for the above tests are identified in Section 3.1.

### 2.7.5 Test Method and Operating Modes

The test was applied in accordance with the test method requirements of FCC CFR 47 Part 2 and Part 24 and Industry Canada RSS-133.

In accordance with Part 2.1051, the spurious emissions from the antenna terminal were measured. The transmitter output power was attenuated using an attenuator and the frequency spectrum investigated from 9kHz to 20GHz. The EUT was set to transmit on maximum power. The EUT was tested on with GMSK, 8-PSK, 16QAM and 32QAM modulation types. The resolution was set to 1MHz for 9kHz to 20GHz thus meeting the requirements of Part 24.238(b). The spectrum analyser detector was set to peak and trace was kept on Max Hold.

The maximum path loss across the measurement band was used as the reference level offset to ensure worst case.

In addition, measurements were made up to the 10<sup>th</sup> harmonic of the fundamental.

The test was performed with the EUT in the following configurations and modes of operation:

- Configuration 1 - Mode 1
- Mode 2
- Mode 3
- Configuration 2 - Mode 1
- Mode 2
- Mode 3
- Configuration 3 - Mode 1
- Mode 2
- Mode 3



**2.7.6 Environmental Conditions**

	21 March 2011	22 March 2011
Ambient Temperature	24.3°C	26.2°C
Relative Humidity	24.5%	20.4%

**2.7.7 Test Results**

For the period of test the EUT met the requirements of FCC CFR 47 Part 2 and Part 24 and Industry Canada RSS-133 for Conducted Spurious Emissions.

The test results are shown below

Remark:

The emissions at 9kHz on the plots was not generated by the test object. A complementary measurement with a smaller Span showed that it was related to the LO feedthrough.

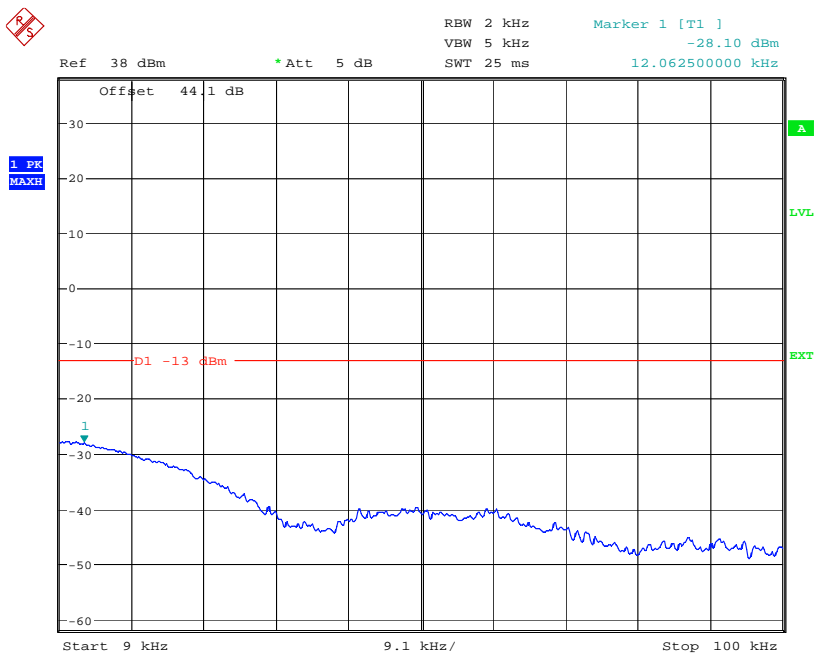

Date: 21.MAR.2011 09:10:52



Product Service

**GMSK**

Configuration 1 - Mode 1

9kHz to 3GHz

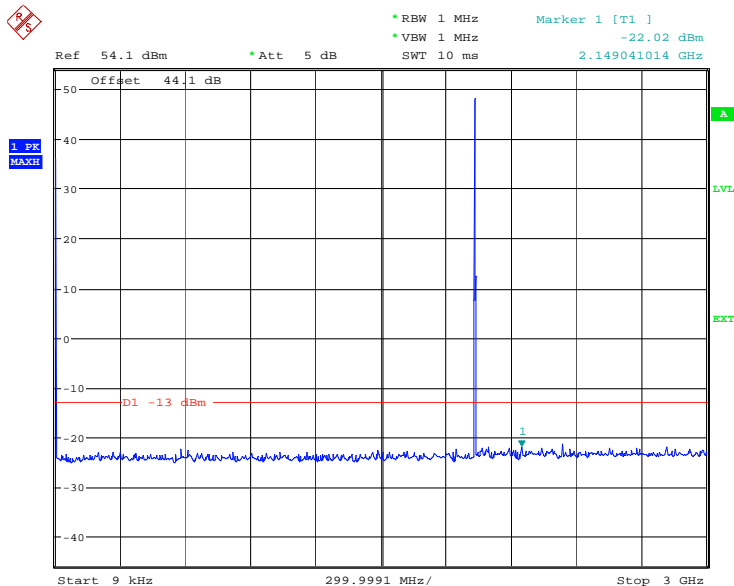

Date: 21.MAR.2011 09:09:55

Note: The emission beyond the limit is the operating frequency.

3GHz to 20GHz

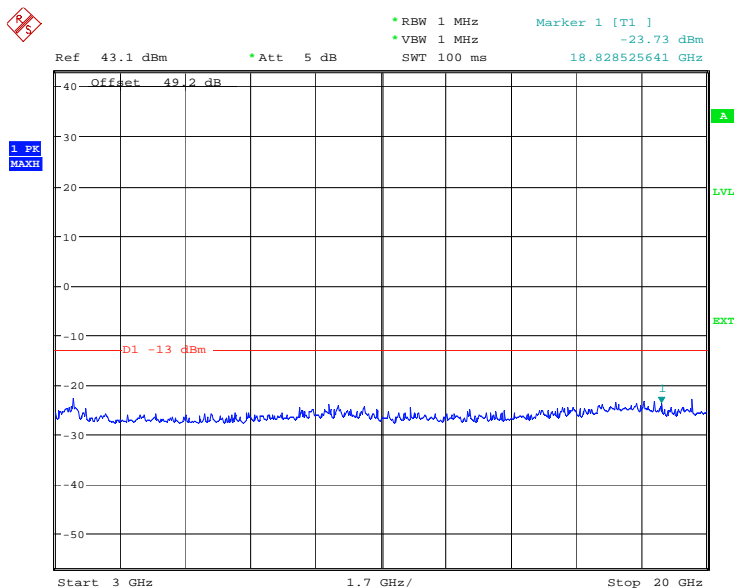

Date: 21.MAR.2011 09:14:44





Configuration 1 - Mode 2

9kHz to 3GHz

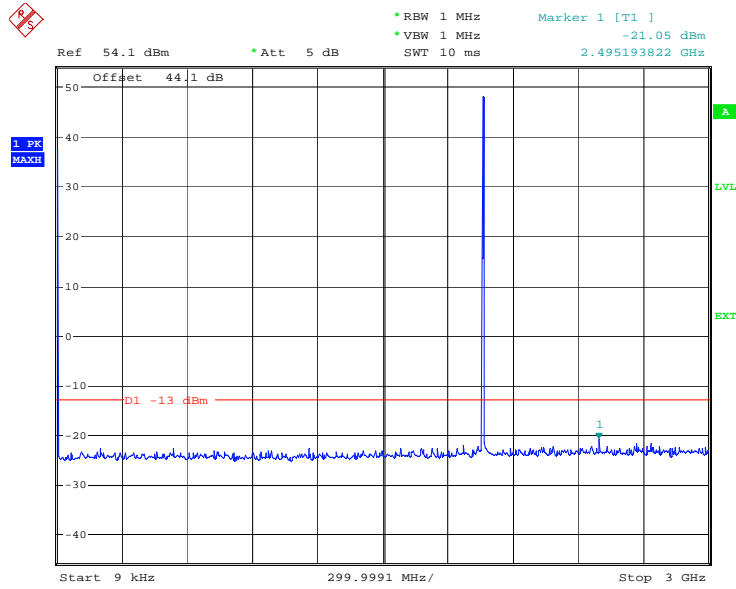

Date: 21.MAR.2011 09:17:13

Note: The emission beyond the limit is the operating frequency.

3GHz to 20GHz

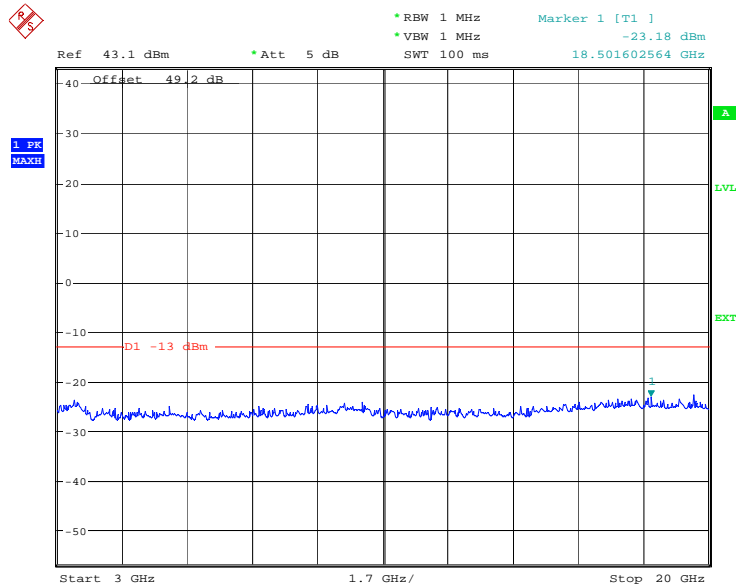

Date: 21.MAR.2011 09:15:57



Product Service

Configuration 1 - Mode 3

9kHz to 3GHz

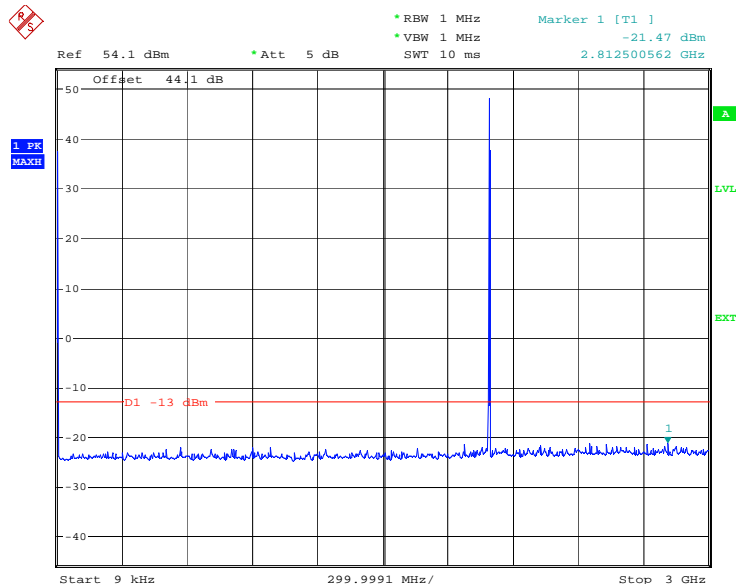

Date: 21.MAR.2011 09:32:52

Note: The emission beyond the limit is the operating frequency.

3GHz to 20GHz

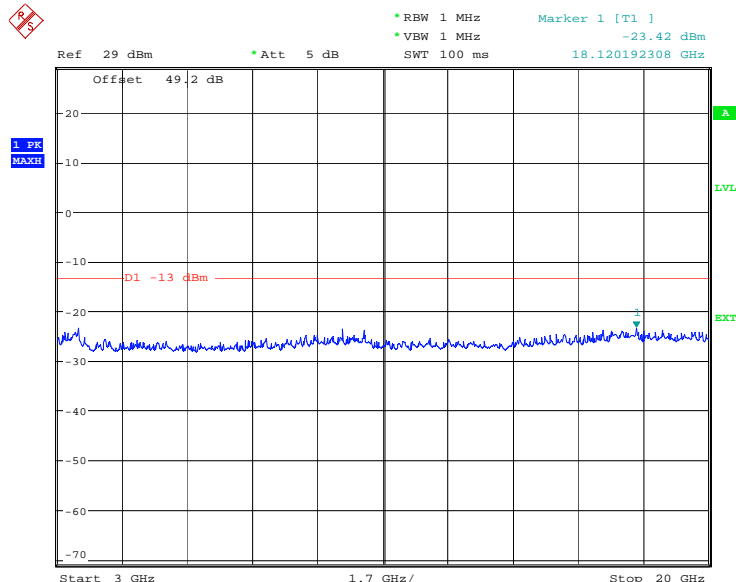

Date: 21.MAR.2011 09:36:28



Configuration 2 - Mode 1

9kHz to 3GHz

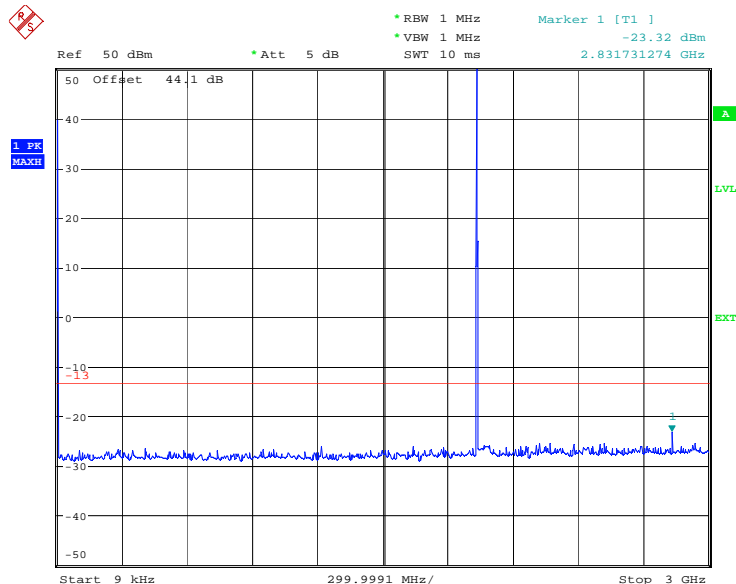

Date: 22.MAR.2011 08:36:04

Note: The emission beyond the limit is the operating frequency.

3GHz to 20GHz

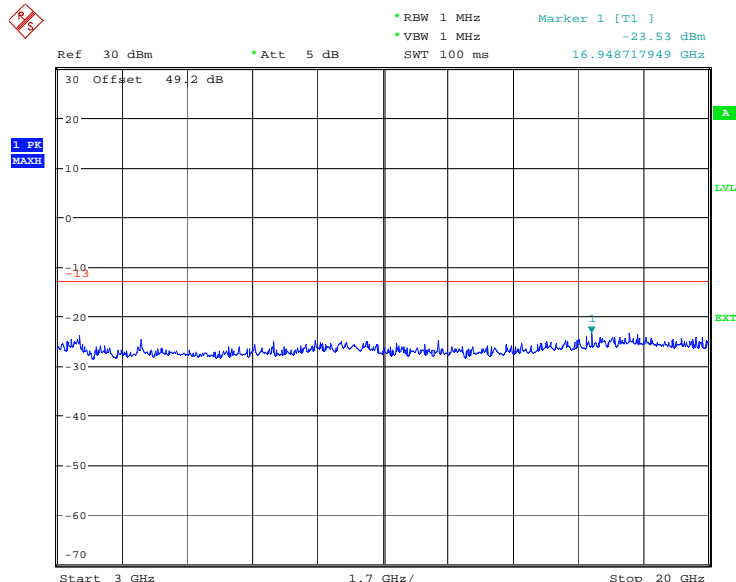

Date: 22.MAR.2011 08:36:40



Product Service

Configuration 2 - Mode 2

9kHz to 3GHz

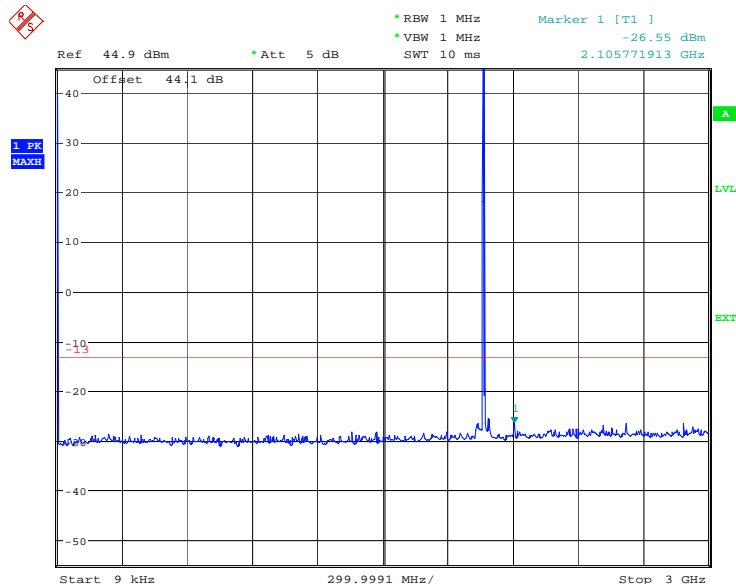

Date: 22.MAR.2011 08:38:52

Note: The emission beyond the limit is the operating frequency.

3GHz to 20GHz

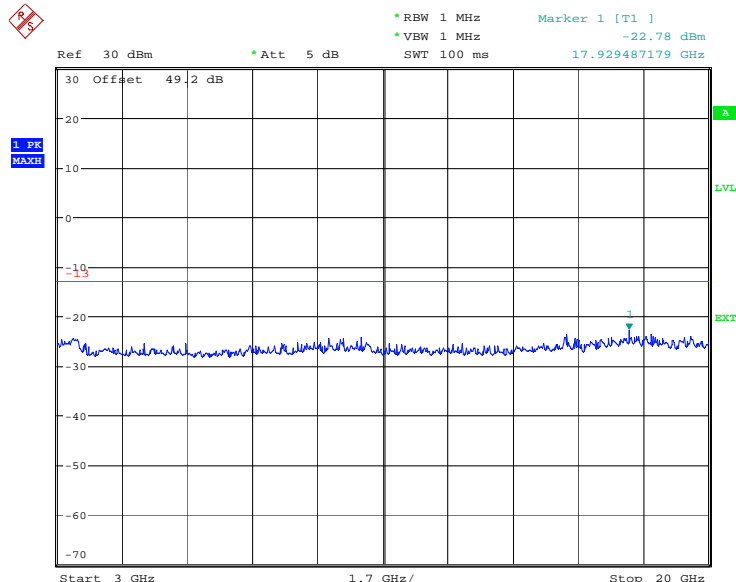

Date: 22.MAR.2011 08:37:50



Product Service

Configuration 2 - Mode 3

9kHz to 3GHz

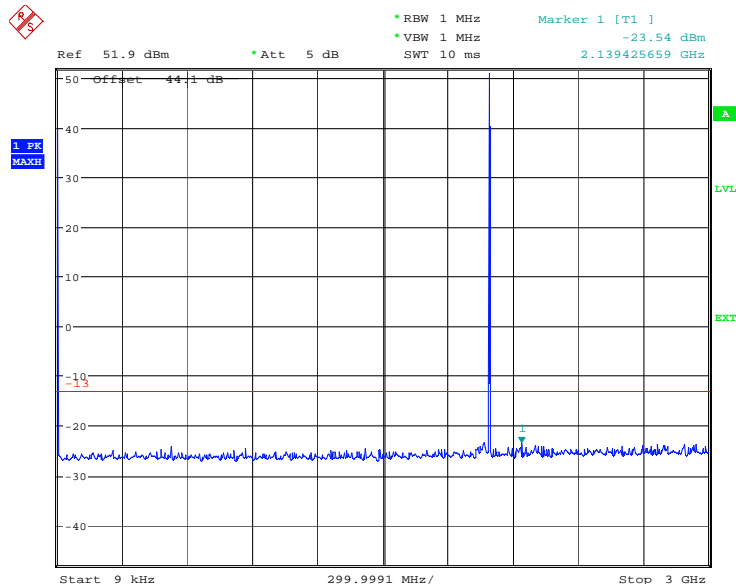

Date: 22.MAR.2011 08:41:56

Note: The emission beyond the limit is the operating frequency.

3GHz to 20GHz

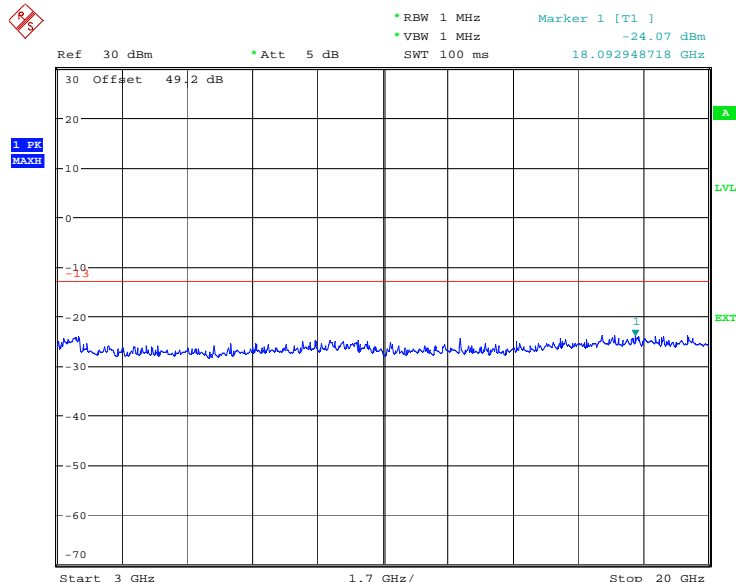

Date: 22.MAR.2011 08:42:46



Product Service

Configuration 3 - Mode 1

9kHz to 3GHz

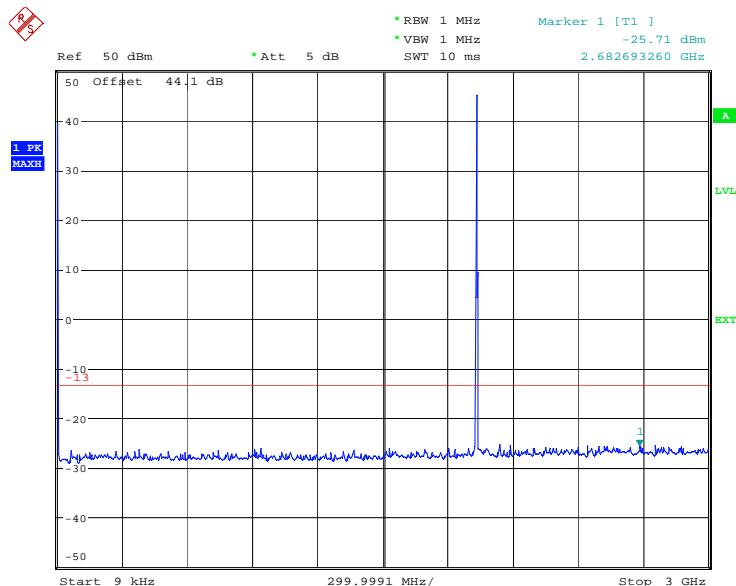

Date: 22.MAR.2011 08:50:21

Note: The emission beyond the limit is the operating frequency.

3GHz to 20GHz

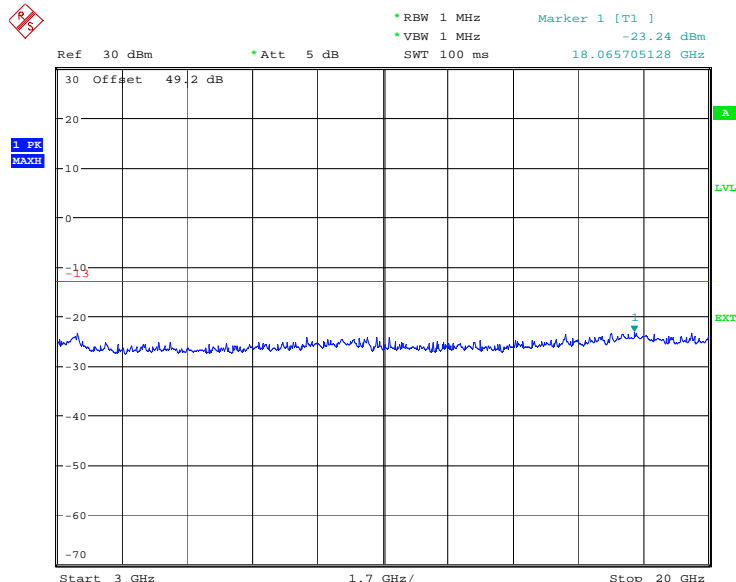

Date: 22.MAR.2011 08:48:47



Configuration 3 - Mode 2

9kHz to 3GHz

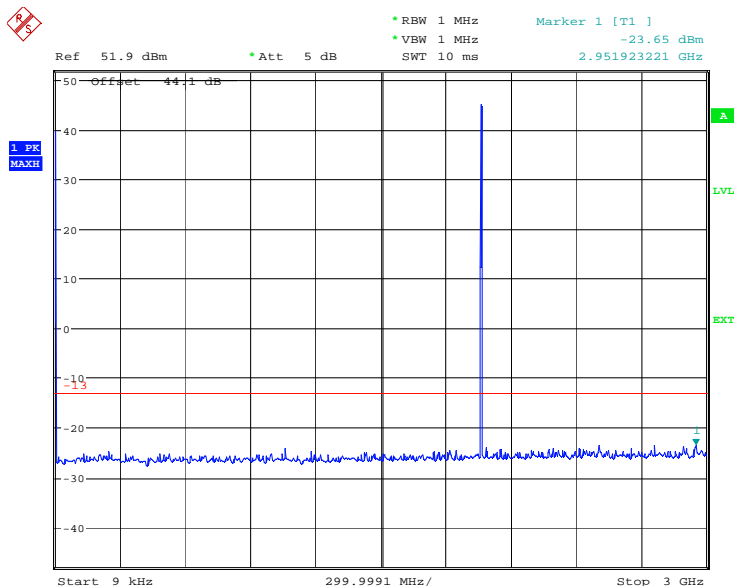

Date: 22.MAR.2011 08:54:19

Note: The emission beyond the limit is the operating frequency.

3GHz to 20GHz

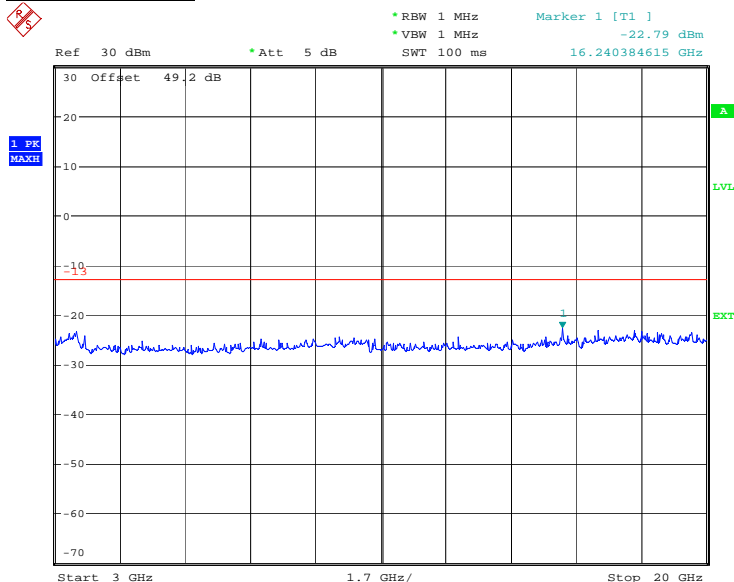

Date: 22.MAR.2011 08:55:14



Product Service

Configuration 3 - Mode 3

9kHz to 3GHz

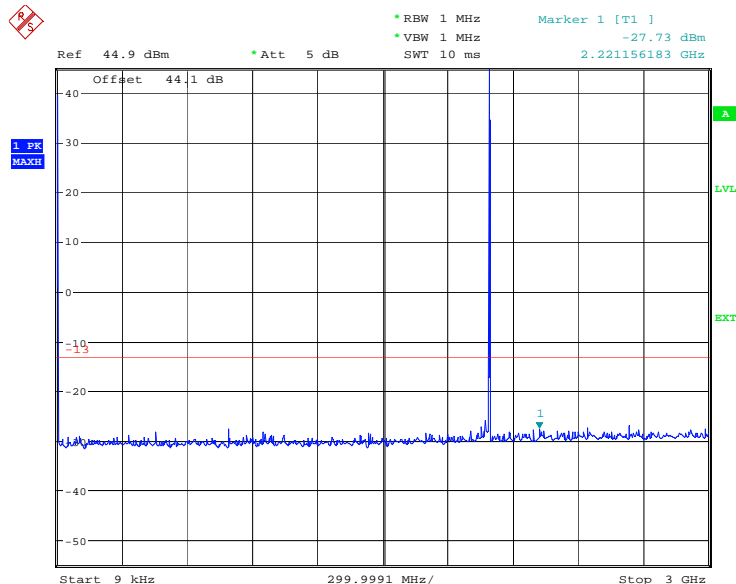

Date: 22.MAR.2011 08:57:53

Note: The emission beyond the limit is the operating frequency.

3GHz to 20GHz

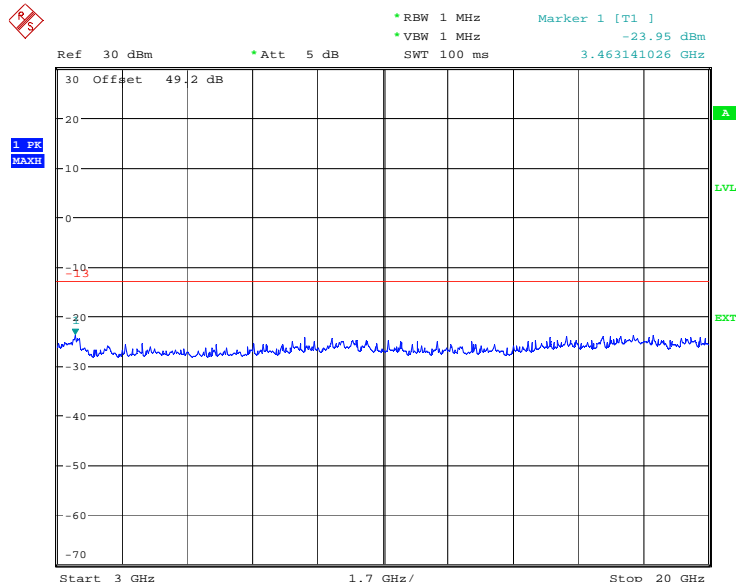

Date: 22.MAR.2011 08:57:08





### 8-PSK

#### Configuration 1 - Mode 1

#### 9kHz to 3GHz

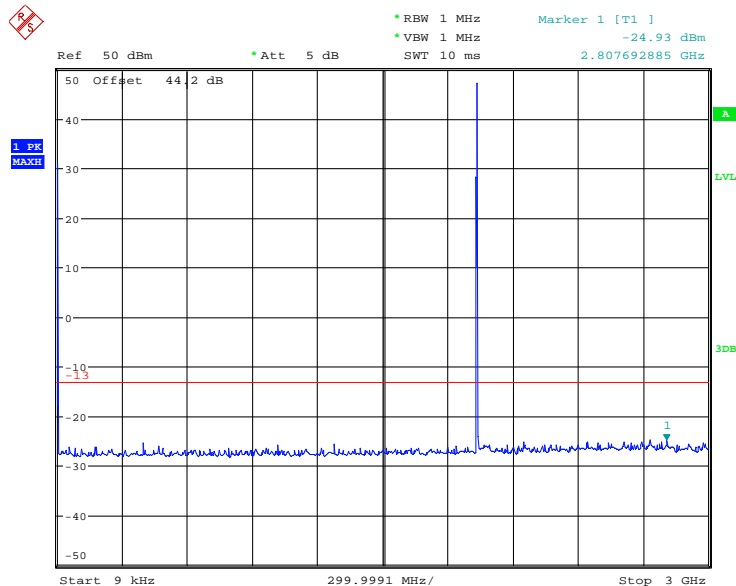

Date: 13.APR.2011 05:46:44

Note: The emission beyond the limit is the operating frequency.

#### 3GHz to 20GHz

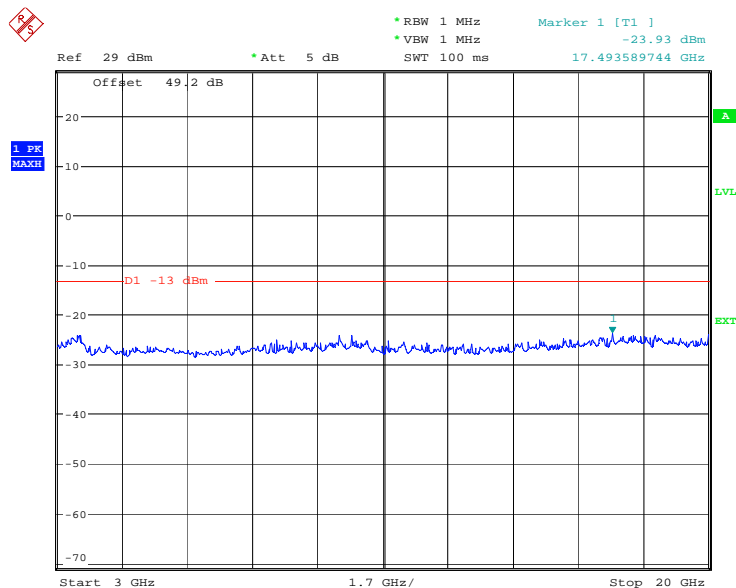

Date: 21.MAR.2011 09:37:37



Product Service

Configuration 1 - Mode 2

9kHz to 3GHz

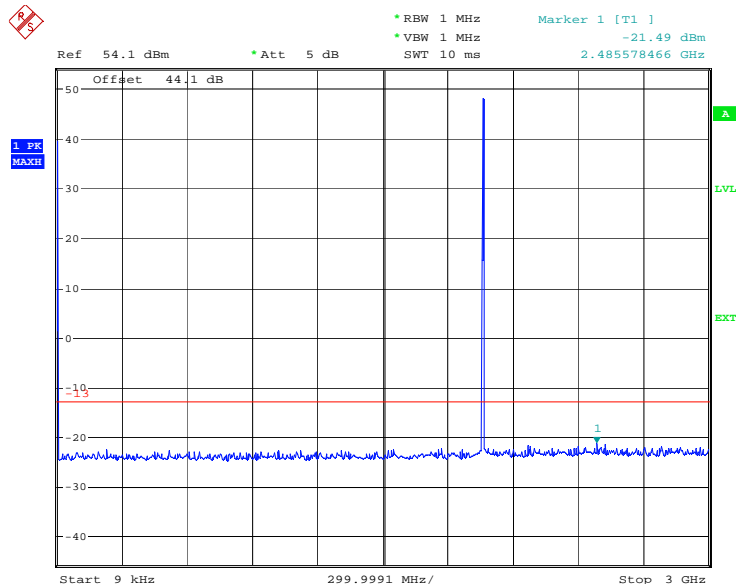

Date: 21.MAR.2011 10:04:34

Note: The emission beyond the limit is the operating frequency.

3GHz to 20GHz

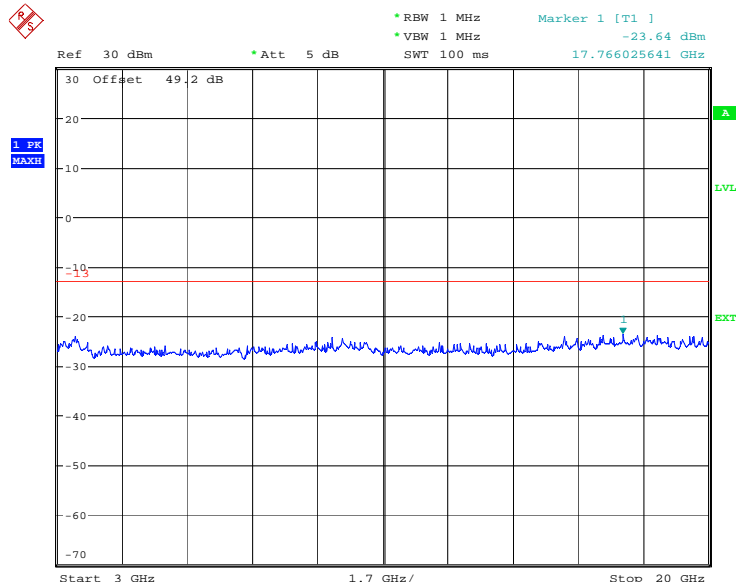

Date: 21.MAR.2011 10:05:18



Product Service

Configuration 1 - Mode 3

9kHz to 3GHz

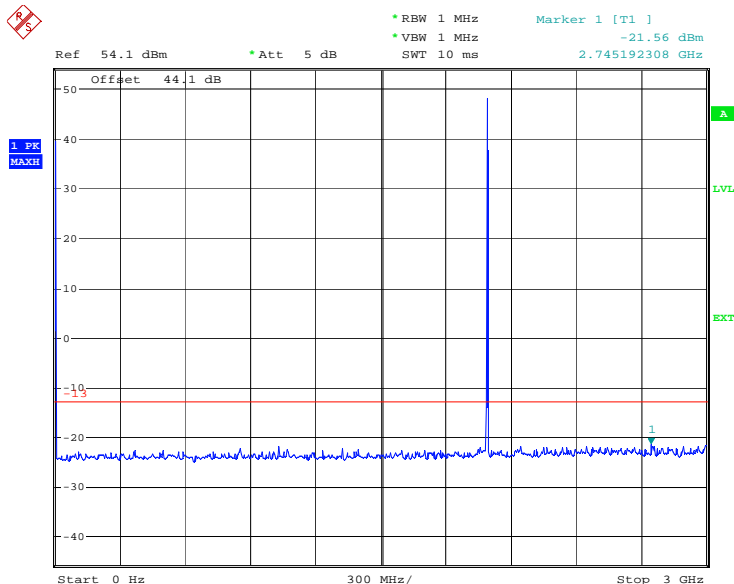

Date: 21.MAR.2011 10:08:59

Note: The emission beyond the limit is the operating frequency.

3GHz to 20GHz

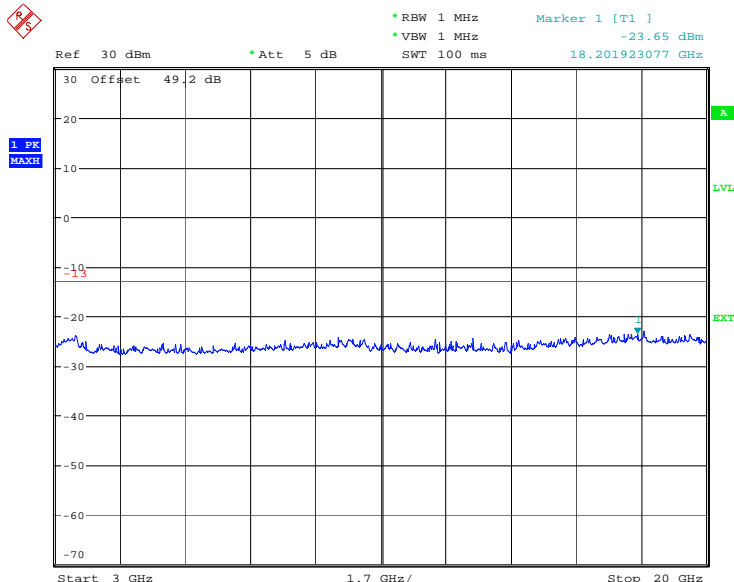

Date: 21.MAR.2011 10:06:47



Configuration 2 - Mode 1

9kHz to 3GHz

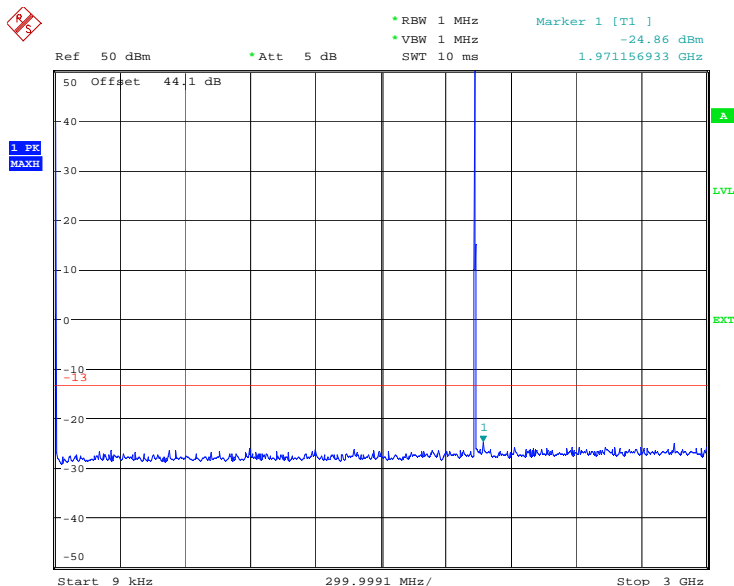

Date: 22.MAR.2011 08:31:13

Note: The emission beyond the limit is the operating frequency.

3GHz to 20GHz

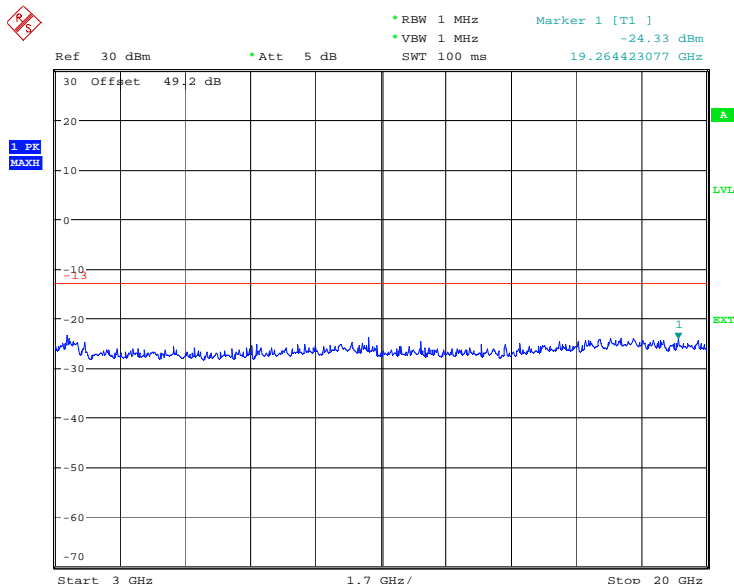

Date: 22.MAR.2011 08:25:38



Product Service

Configuration 2 - Mode 2

9kHz to 3GHz

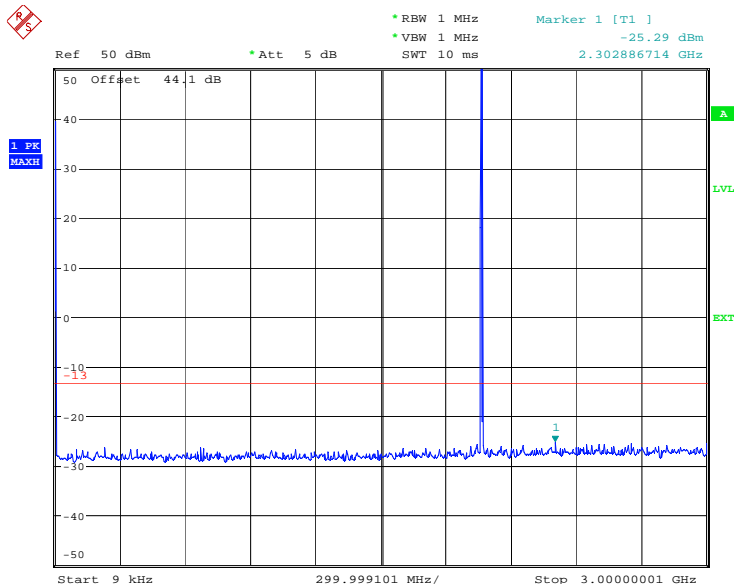

Date: 22.MAR.2011 08:23:51

Note: The emission beyond the limit is the operating frequency.

3GHz to 20GHz

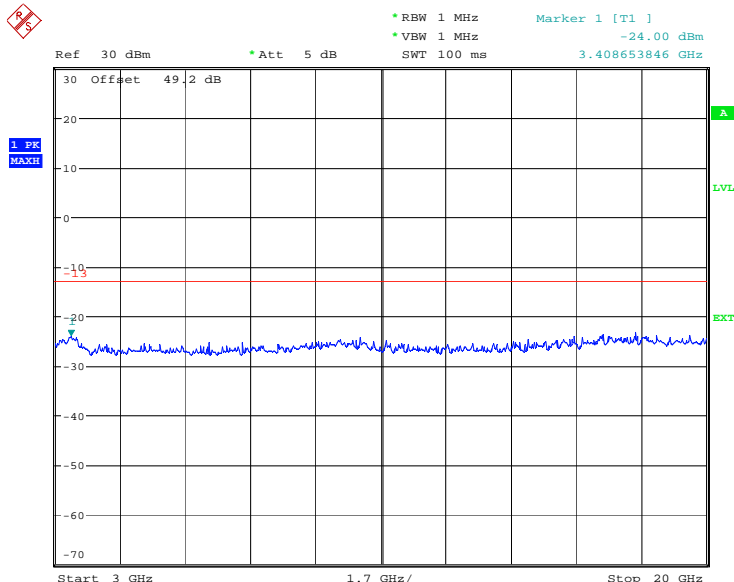

Date: 22.MAR.2011 08:24:52



Product Service

Configuration 2 - Mode 3

9kHz to 3GHz

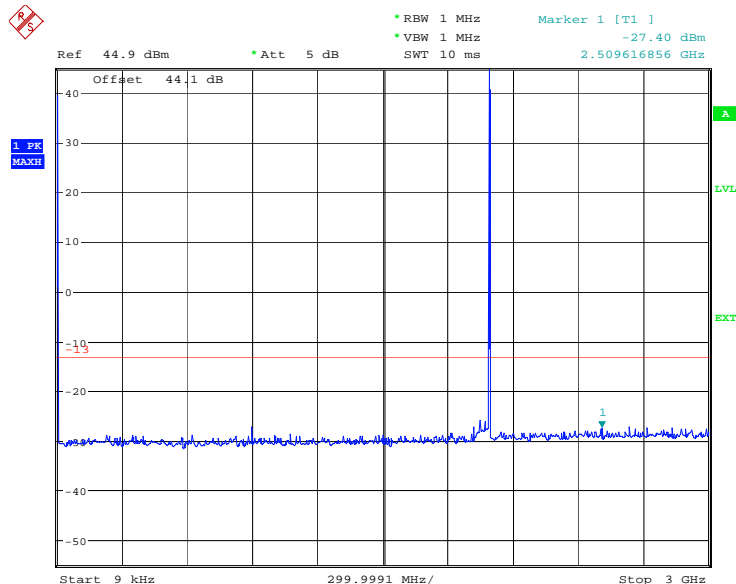

Date: 22.MAR.2011 08:19:40

Note: The emission beyond the limit is the operating frequency.

3GHz to 20GHz

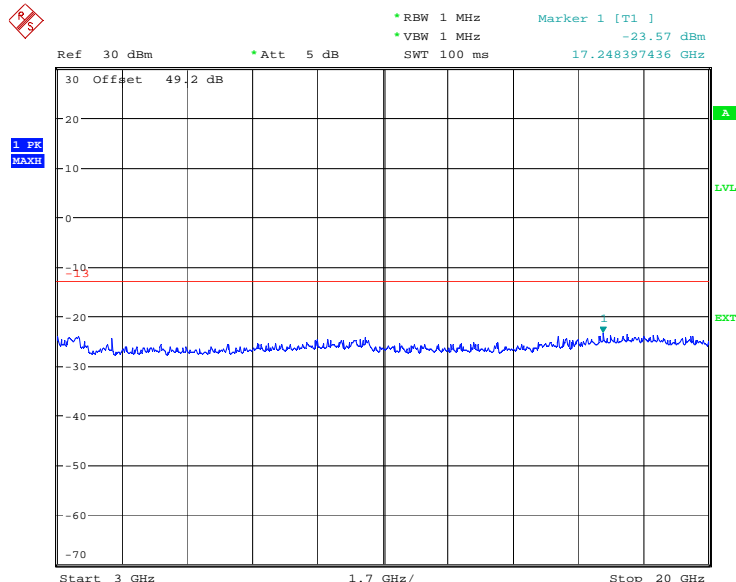

Date: 22.MAR.2011 08:17:42



Configuration 3 - Mode 1

9kHz to 3GHz

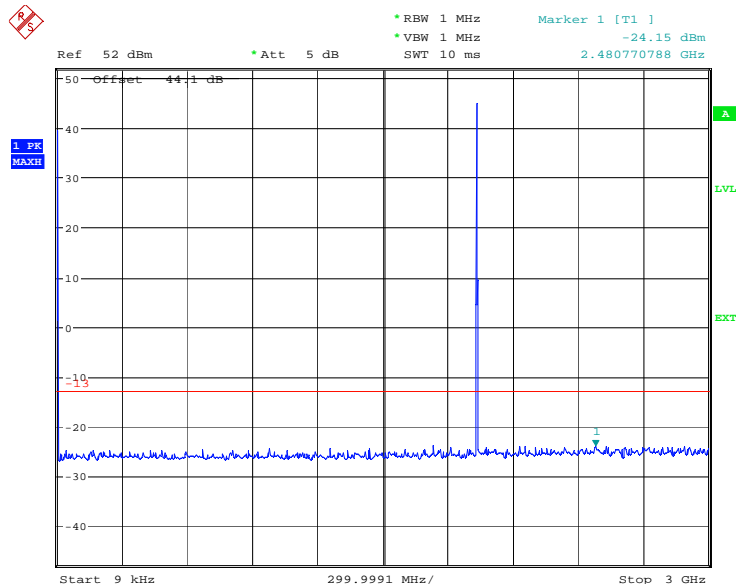

Date: 22.MAR.2011 09:05:48

Note: The emission beyond the limit is the operating frequency.

3GHz to 20GHz

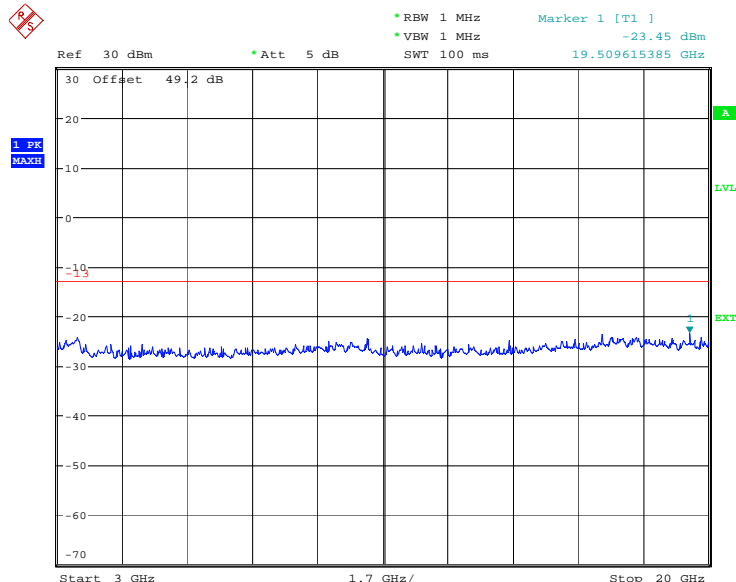

Date: 22.MAR.2011 09:06:18



Product Service

Configuration 3 - Mode 2

9kHz to 3GHz

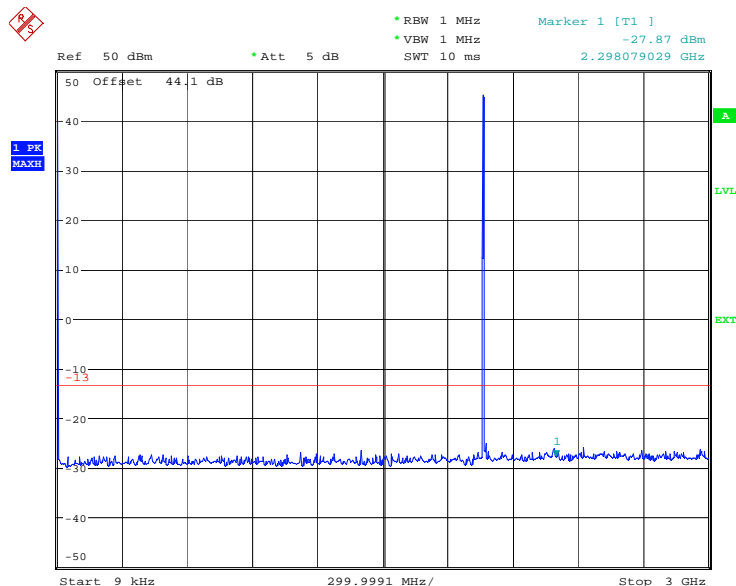

Date: 22.MAR.2011 09:02:31

Note: The emission beyond the limit is the operating frequency.

3GHz to 20GHz

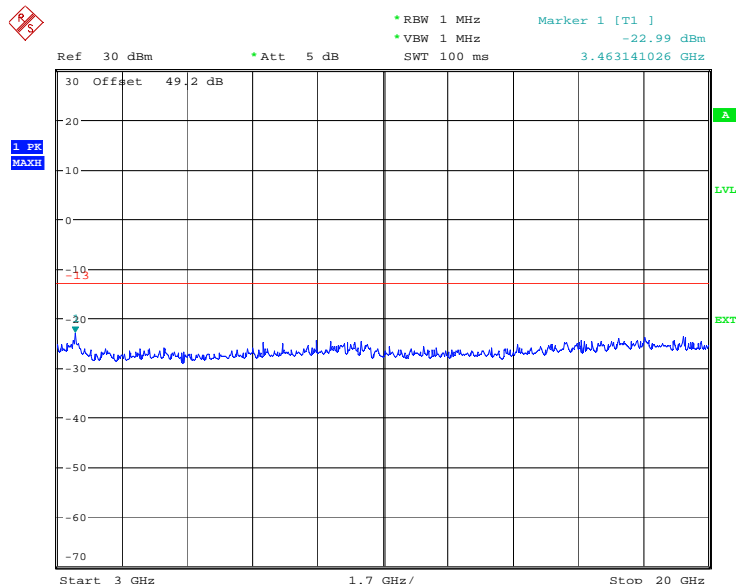

Date: 22.MAR.2011 09:01:51





Configuration 3 - Mode 3

9kHz to 3GHz

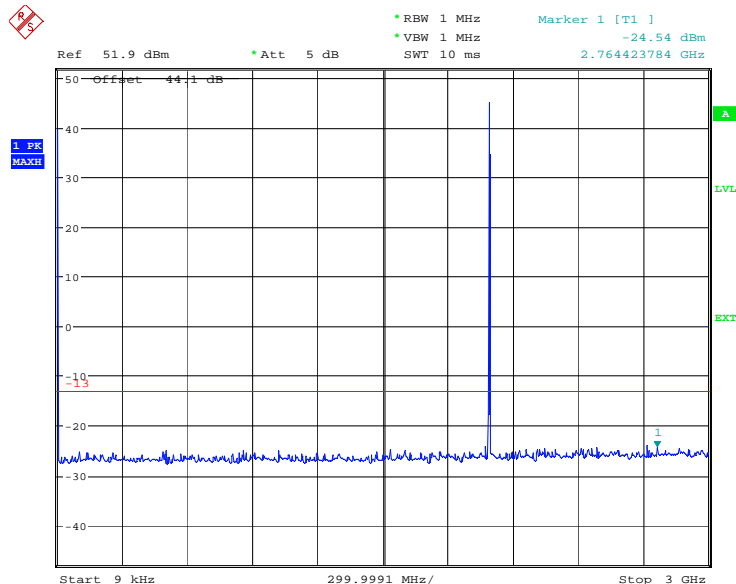

Date: 22.MAR.2011 09:00:15

Note: The emission beyond the limit is the operating frequency.

3GHz to 20GHz

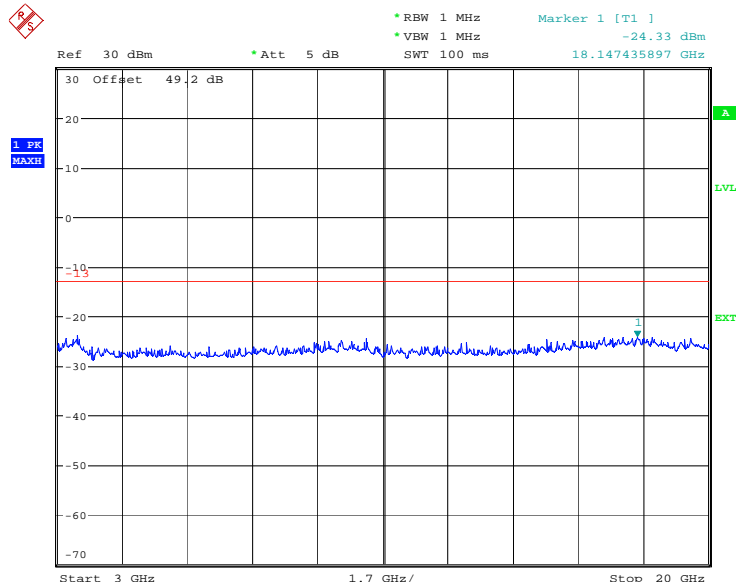

Date: 22.MAR.2011 09:00:46



Product Service

### 16QAM

#### Configuration 1 - Mode 1

#### 9kHz to 3GHz

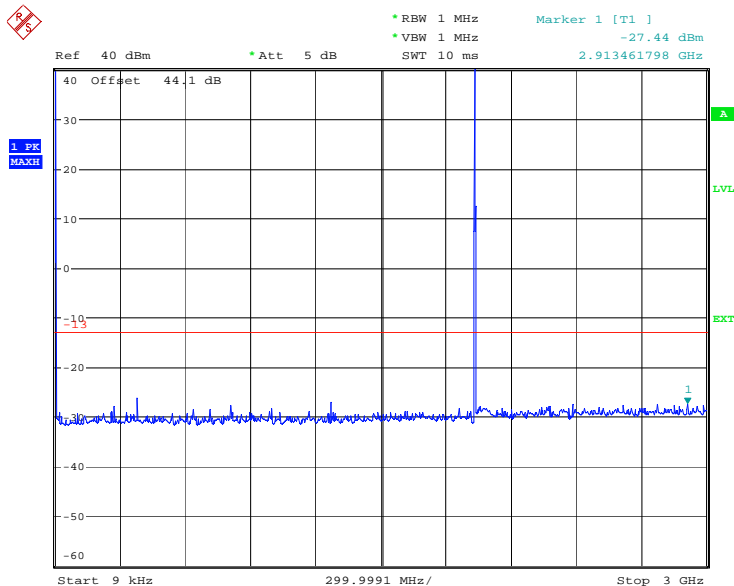

Date: 21.MAR.2011 13:05:01

Note: The emission beyond the limit is the operating frequency.

#### 3GHz to 20GHz

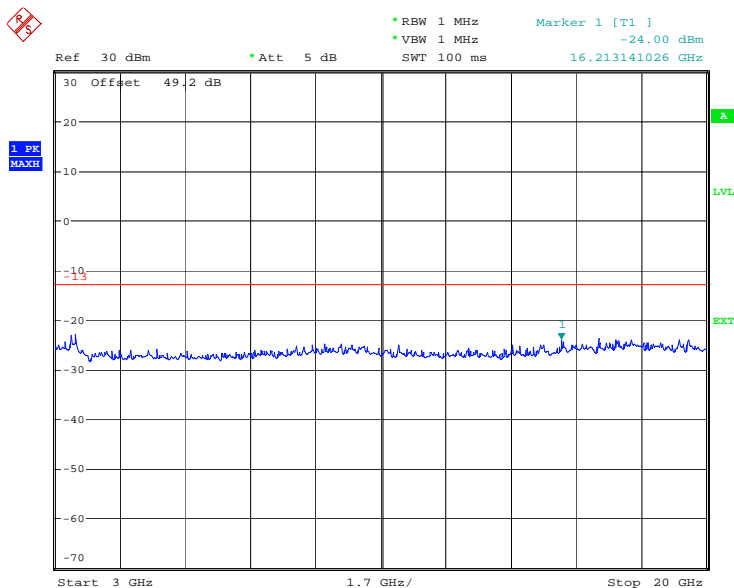

Date: 21.MAR.2011 13:06:14



Product Service

Configuration 1 - Mode 2

9kHz to 3GHz

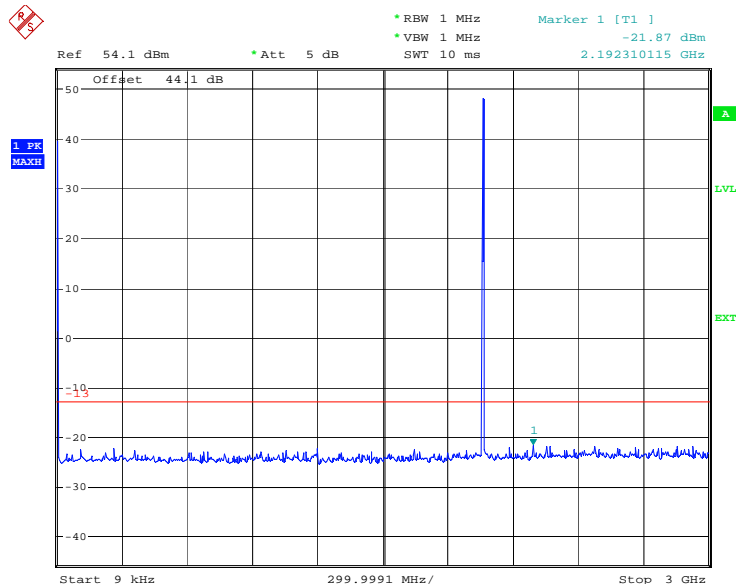

Date: 21.MAR.2011 13:09:01

Note: The emission beyond the limit is the operating frequency.

3GHz to 20GHz

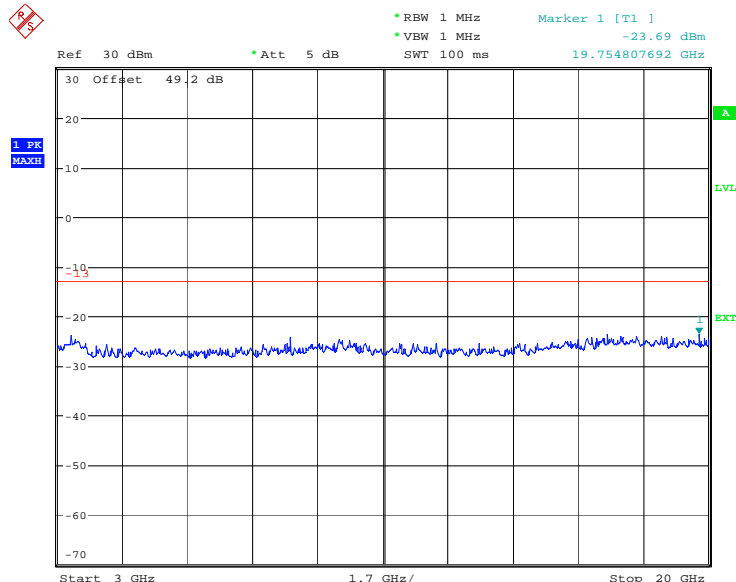

Date: 21.MAR.2011 13:07:51



Configuration 1 - Mode 3

9kHz to 3GHz

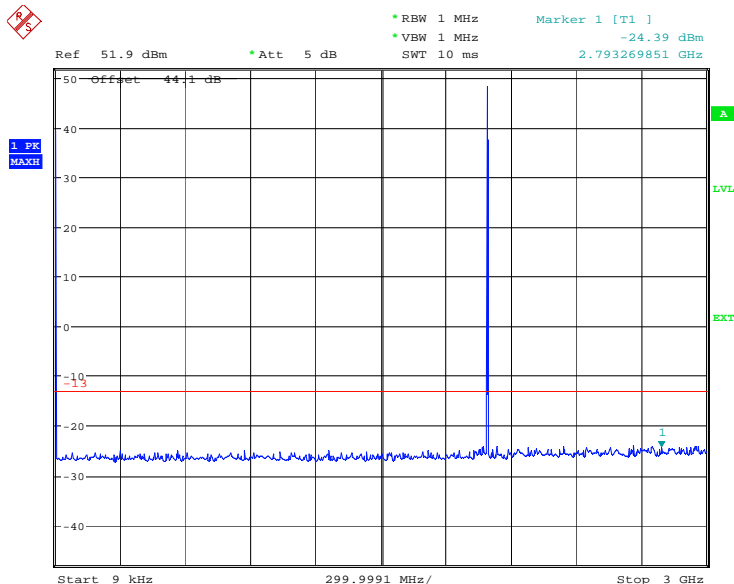

Date: 21.MAR.2011 13:15:50

Note: The emission beyond the limit is the operating frequency.

3GHz to 20GHz

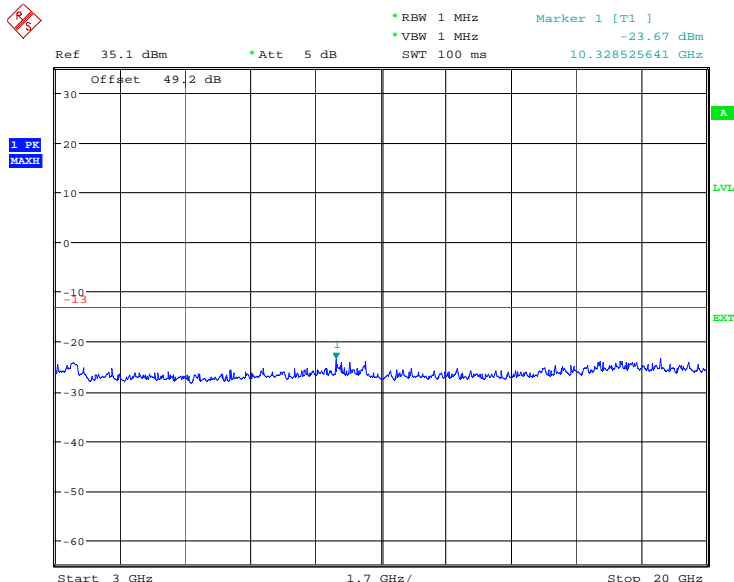

Date: 21.MAR.2011 13:16:38



Configuration 2 - Mode 1

9kHz to 3GHz

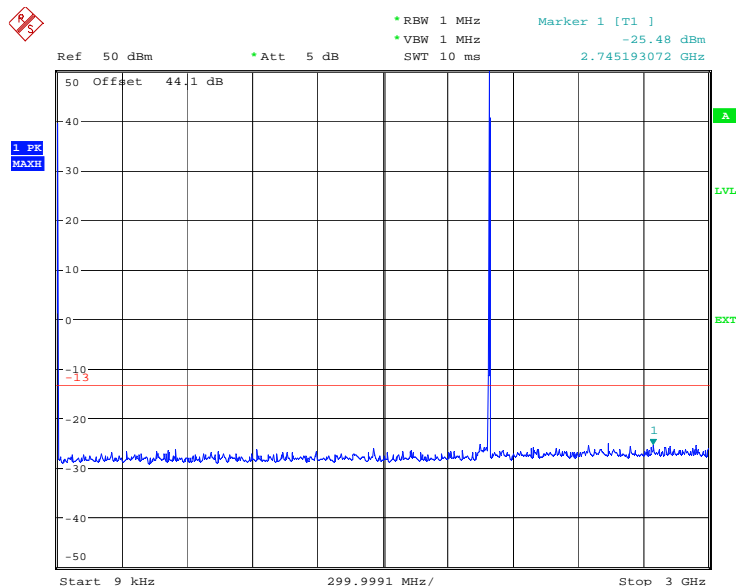

Date: 21.MAR.2011 15:42:04

Note: The emission beyond the limit is the operating frequency.

3GHz to 20GHz

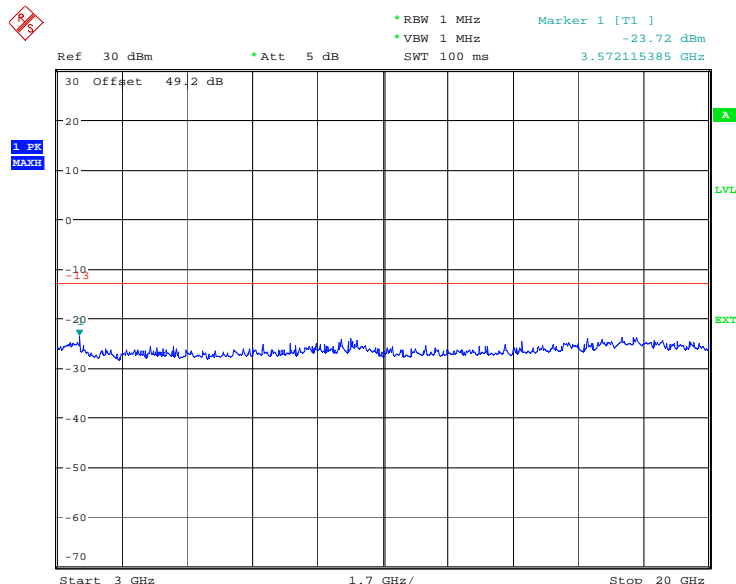

Date: 21.MAR.2011 15:42:55



Product Service

Configuration 2 - Mode 2

9kHz to 3GHz

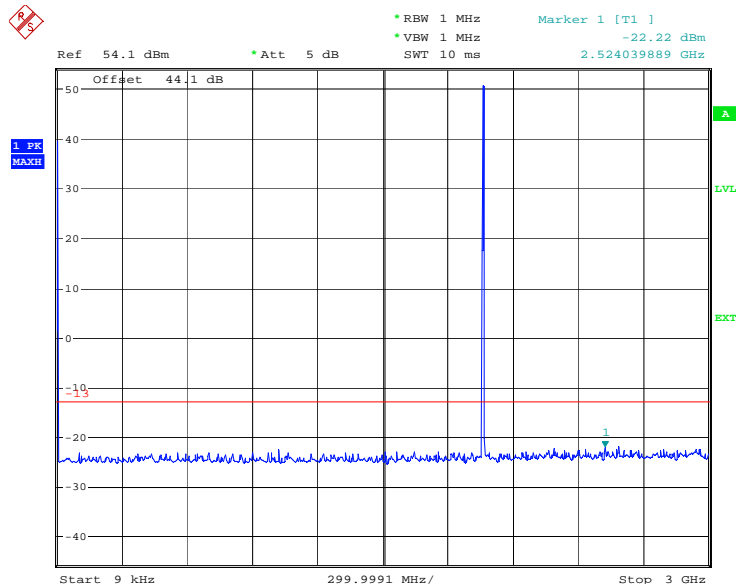

Date: 21.MAR.2011 15:44:57

Note: The emission beyond the limit is the operating frequency.

3GHz to 20GHz

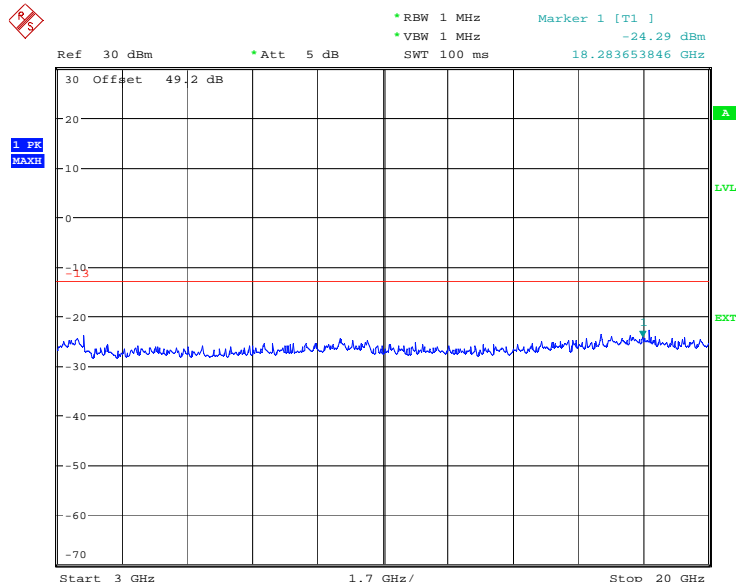

Date: 21.MAR.2011 15:44:01



Configuration 2 - Mode 3

9kHz to 3GHz

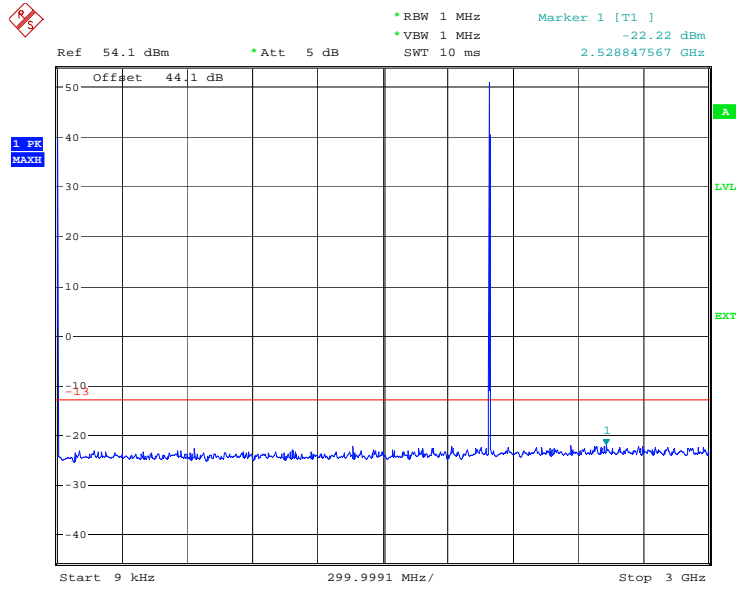

Date: 21.MAR.2011 15:47:25

Note: The emission beyond the limit is the operating frequency.

3GHz to 20GHz

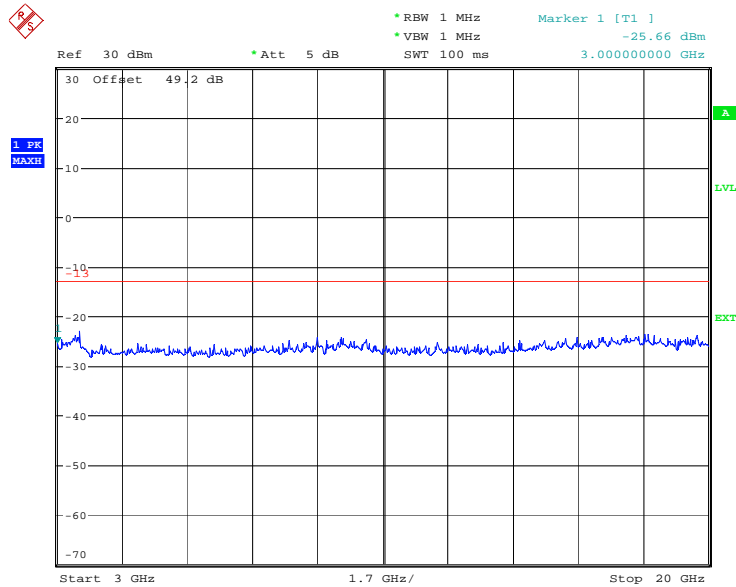

Date: 21.MAR.2011 15:48:50



Configuration 3 - Mode 1

9kHz to 3GHz

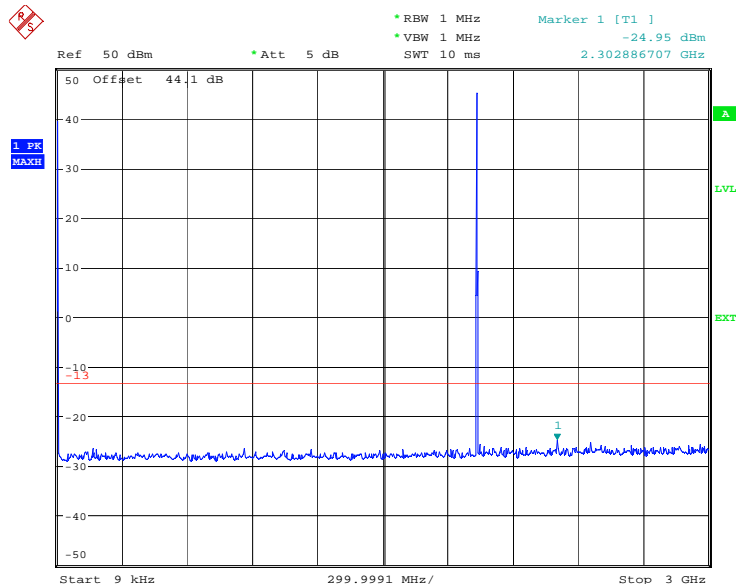

Date: 22.MAR.2011 09:07:46

Note: The emission beyond the limit is the operating frequency.

3GHz to 20GHz

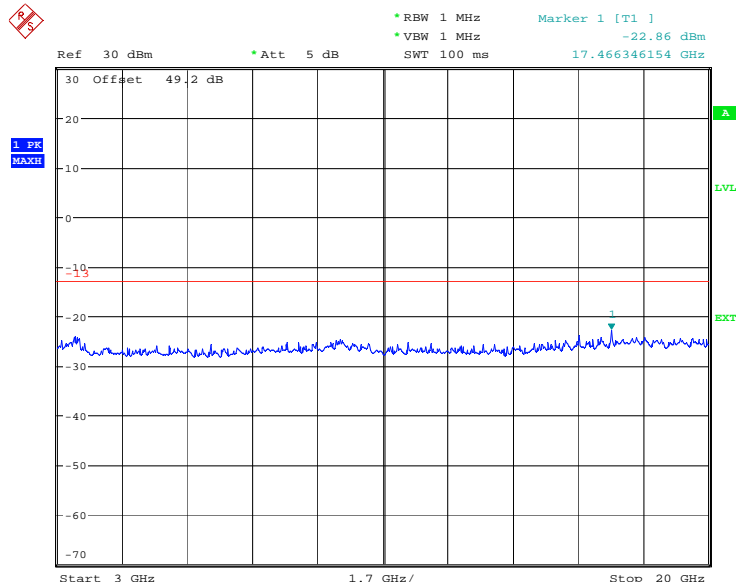

Date: 22.MAR.2011 09:06:57





Configuration 3 - Mode 2

9kHz to 3GHz

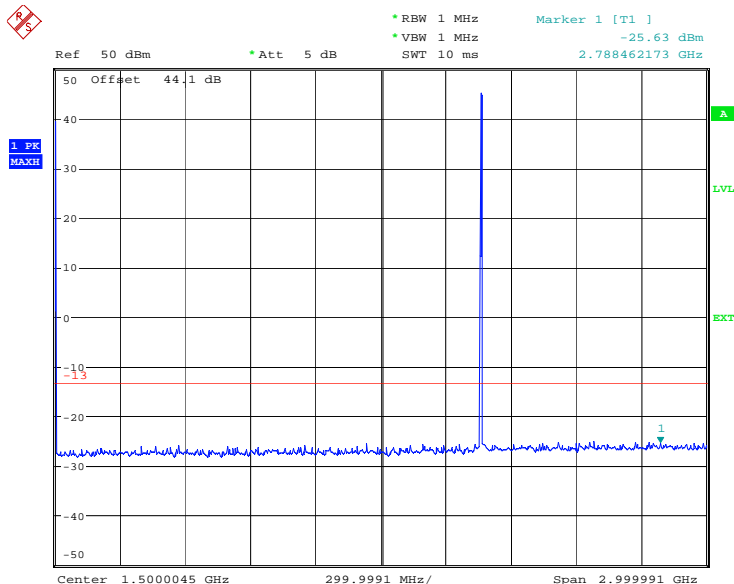

Date: 22.MAR.2011 09:16:08

Note: The emission beyond the limit is the operating frequency.

3GHz to 20GHz

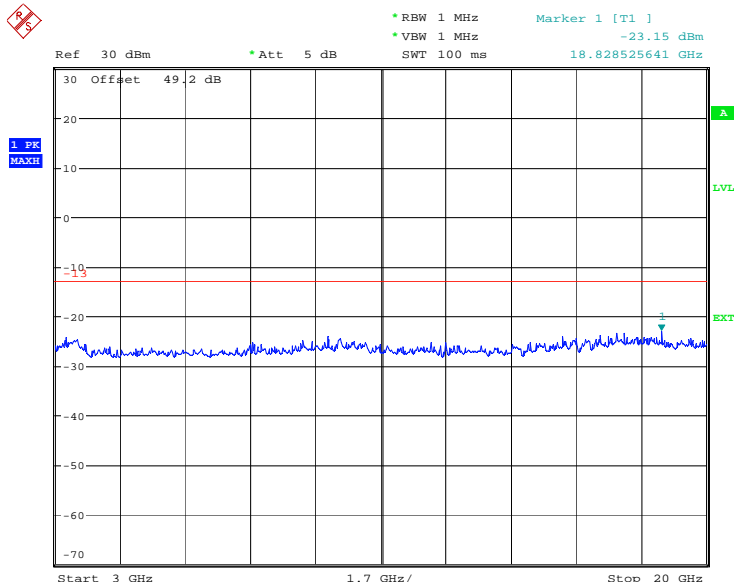

Date: 22.MAR.2011 09:16:47



Product Service

Configuration 3 - Mode 3

9kHz to 3GHz

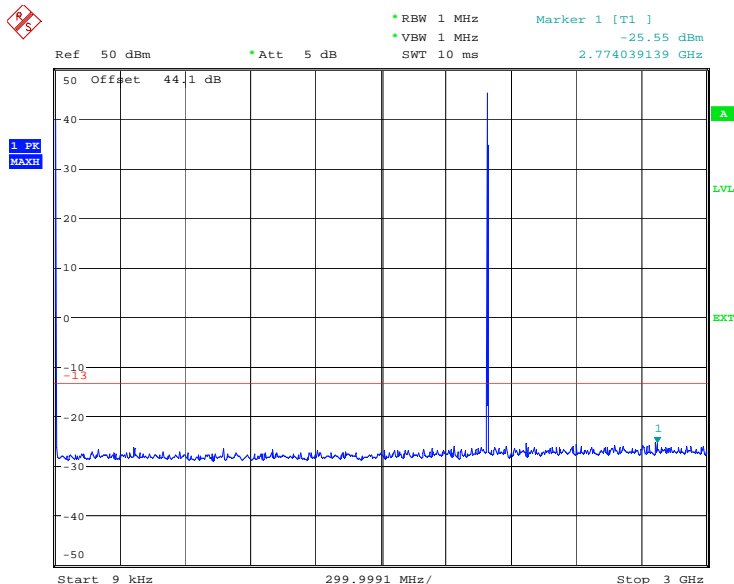

Date: 22.MAR.2011 09:19:35

Note: The emission beyond the limit is the operating frequency.

3GHz to 20GHz

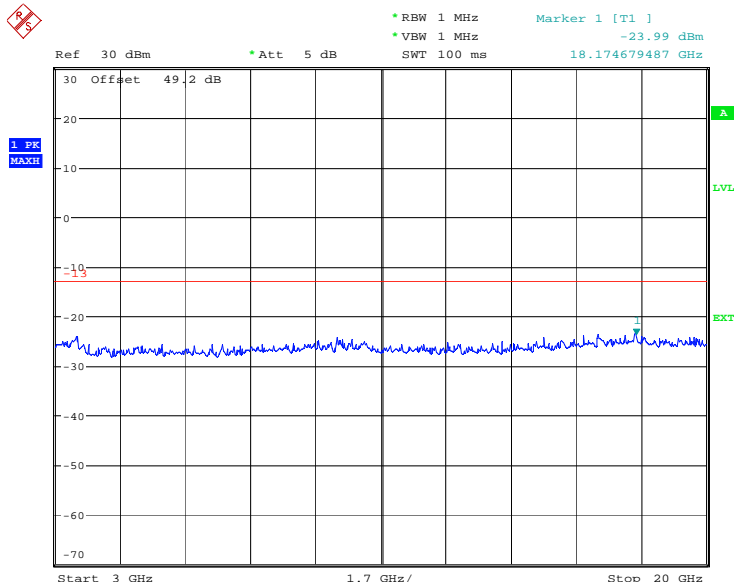

Date: 22.MAR.2011 09:17:41



Product Service

### 32QAM

#### Configuration 1 - Mode 1

#### 9kHz to 3GHz

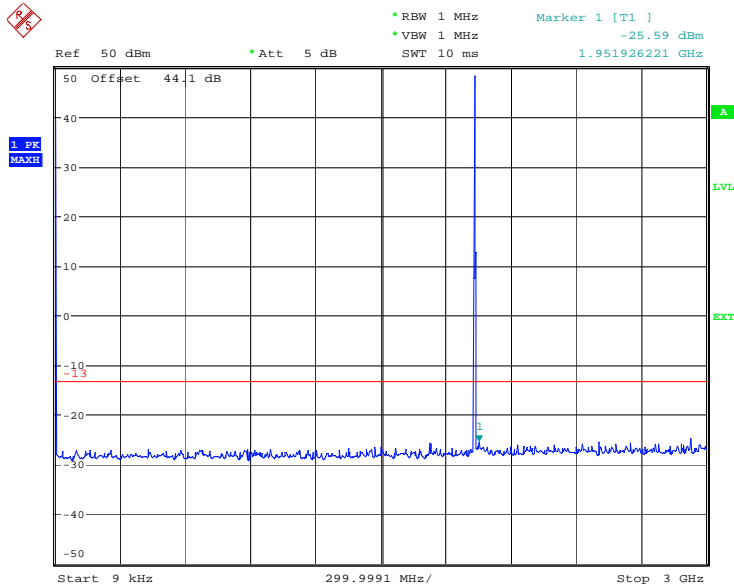

Date: 21.MAR.2011 14:04:39

Note: The emission beyond the limit is the operating frequency.

#### 3GHz to 20GHz

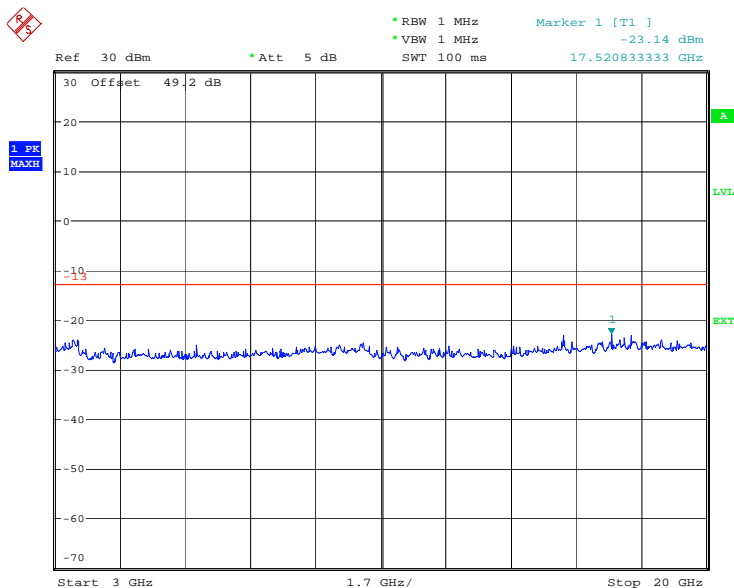

Date: 21.MAR.2011 14:03:45



Configuration 1 - Mode 2

9kHz to 3GHz

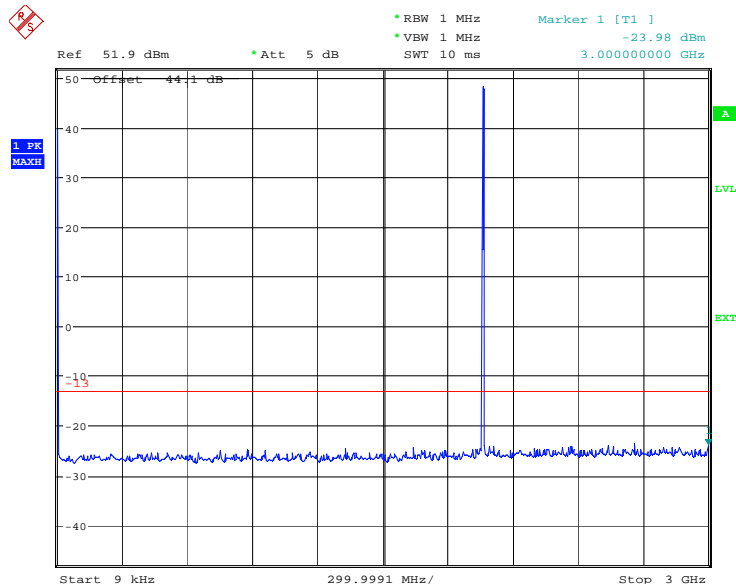

Date: 21.MAR.2011 13:27:44

Note: The emission beyond the limit is the operating frequency.

3GHz to 20GHz

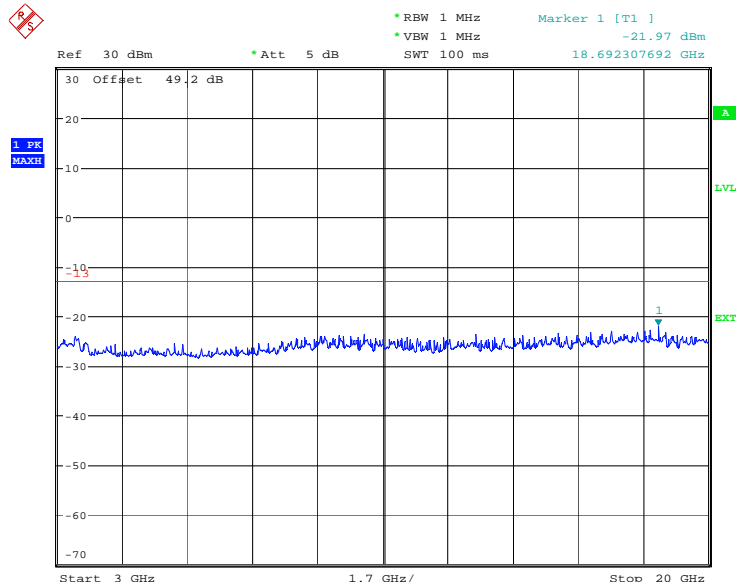

Date: 21.MAR.2011 13:28:28



Configuration 1 - Mode 3

9kHz to 3GHz

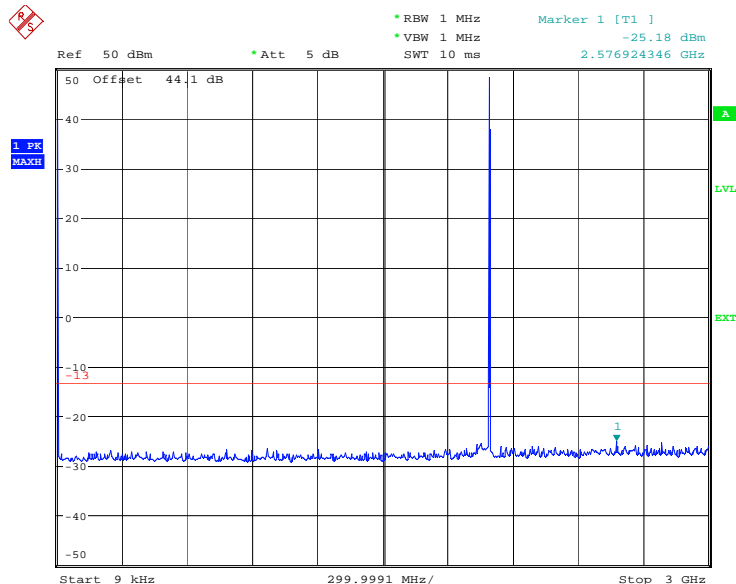

Date: 21.MAR.2011 13:18:16

Note: The emission beyond the limit is the operating frequency.

3GHz to 20GHz

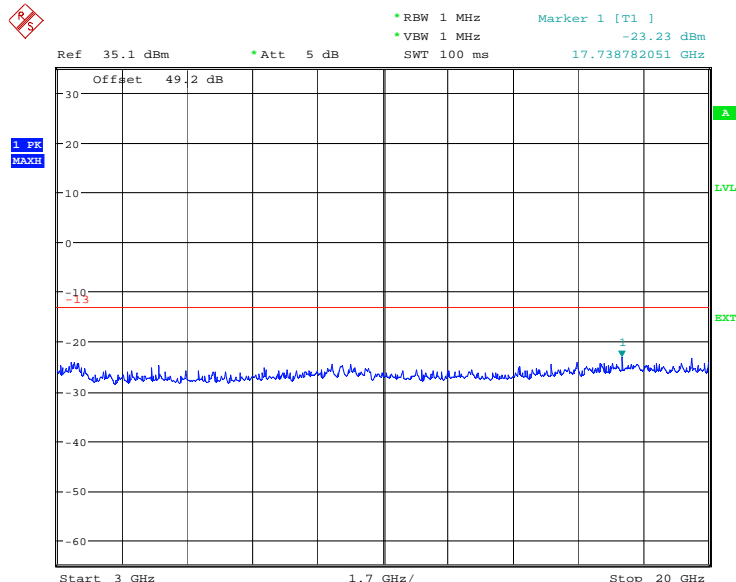

Date: 21.MAR.2011 13:17:25



Configuration 2 - Mode 1

9kHz to 3GHz

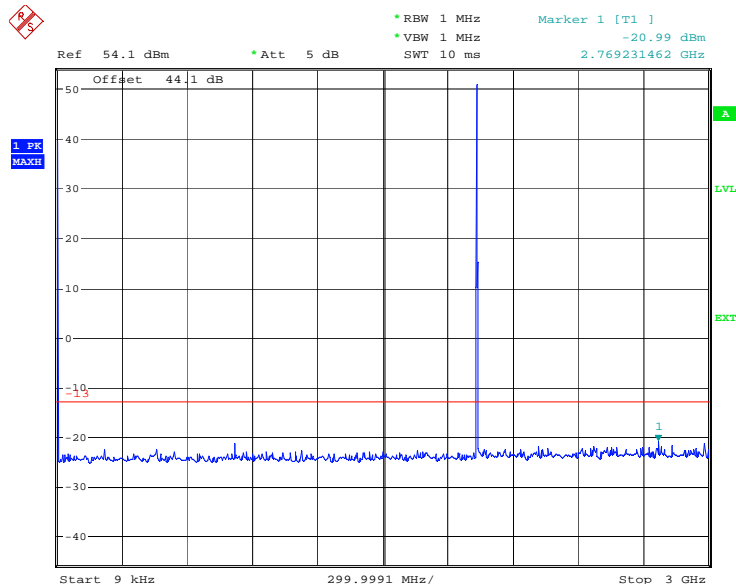

Date: 21.MAR.2011 15:32:12

Note: The emission beyond the limit is the operating frequency.

3GHz to 20GHz

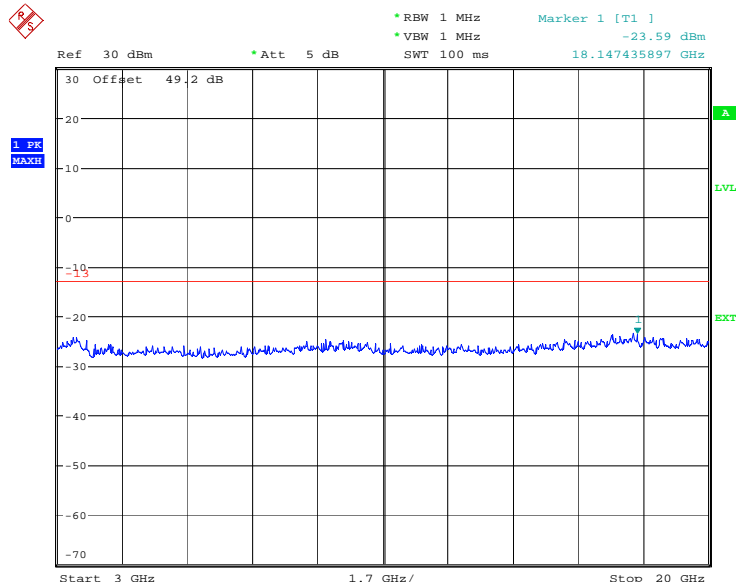

Date: 21.MAR.2011 15:33:19



Product Service

Configuration 2 - Mode 2

9kHz to 3GHz

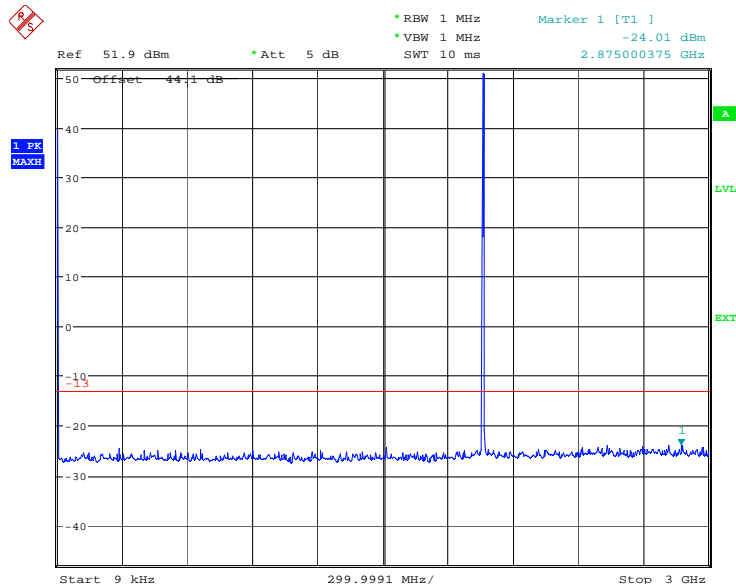

Date: 21.MAR.2011 15:36:58

Note: The emission beyond the limit is the operating frequency.

3GHz to 20GHz

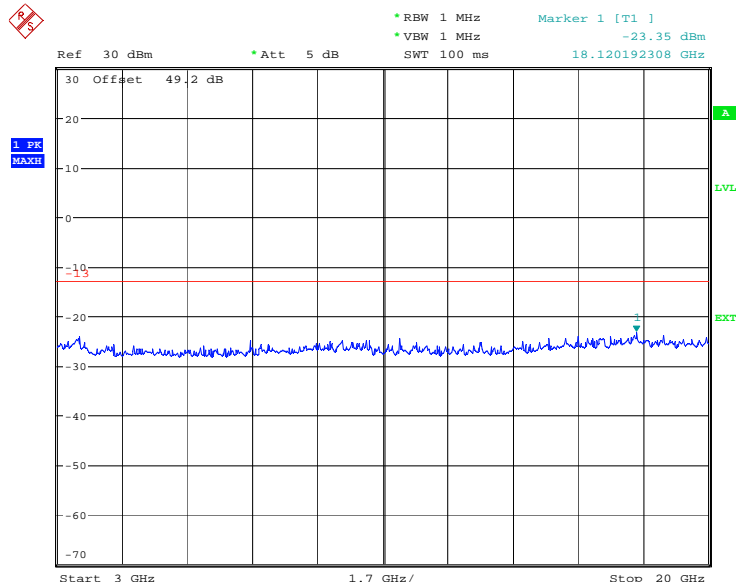

Date: 21.MAR.2011 15:37:43



Product Service

Configuration 2 - Mode 3

9kHz to 3GHz

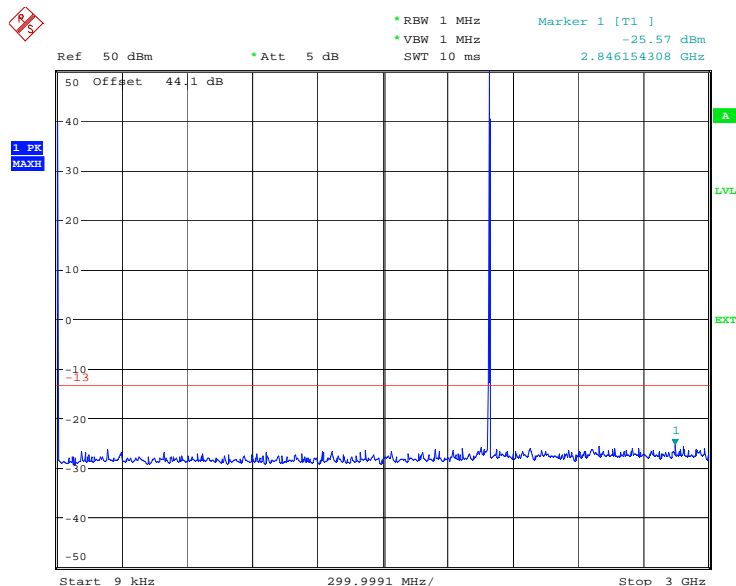

Date: 21.MAR.2011 15:39:03

Note: The emission beyond the limit is the operating frequency.

3GHz to 20GHz

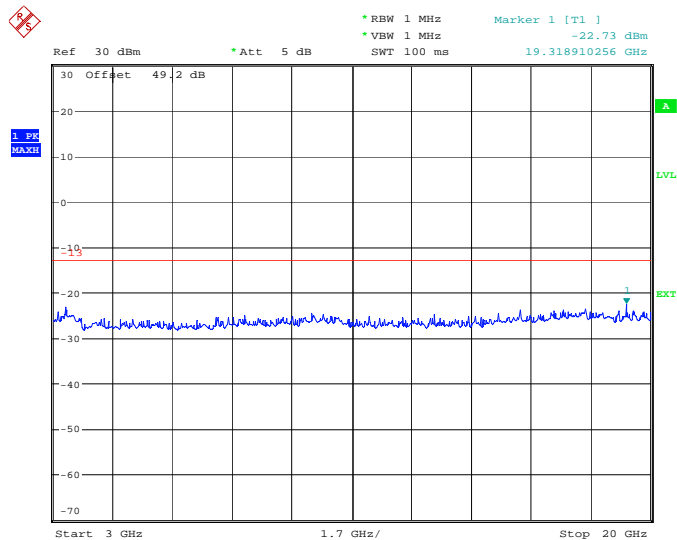

Date: 21.MAR.2011 15:38:29





Product Service

Configuration 3 - Mode 1

9kHz to 3GHz

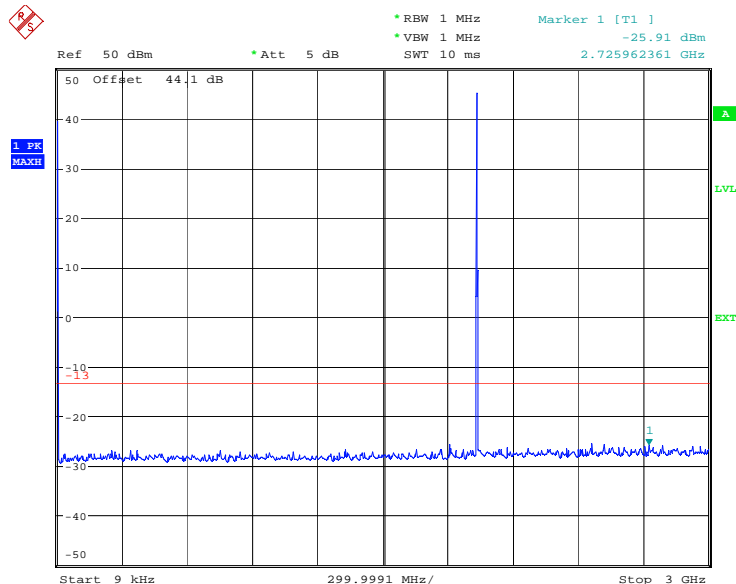

Date: 22.MAR.2011 09:35:07

Note: The emission beyond the limit is the operating frequency.

3GHz to 20GHz

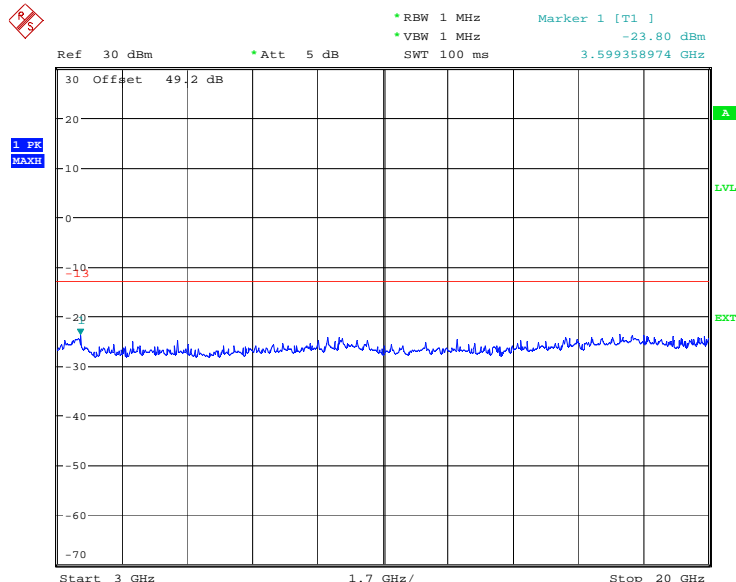

Date: 22.MAR.2011 09:36:04



Product Service

Configuration 3 - Mode 2

9kHz to 3GHz

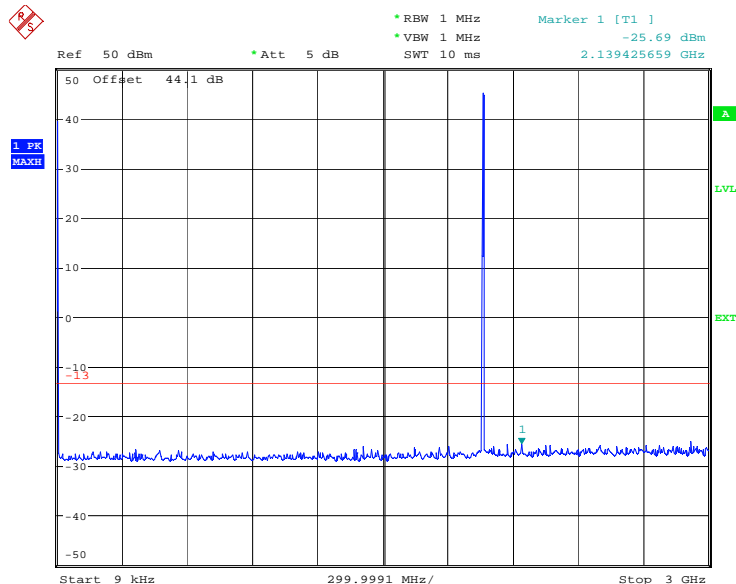

Date: 22.MAR.2011 09:31:47

Note: The emission beyond the limit is the operating frequency.

3GHz to 20GHz

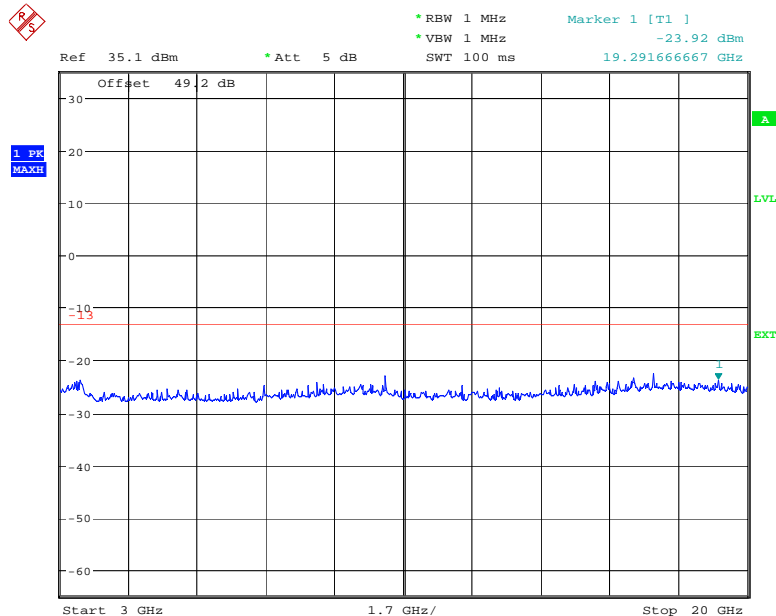

Date: 22.MAR.2011 09:28:48



Configuration 3 - Mode 3

9kHz to 3GHz

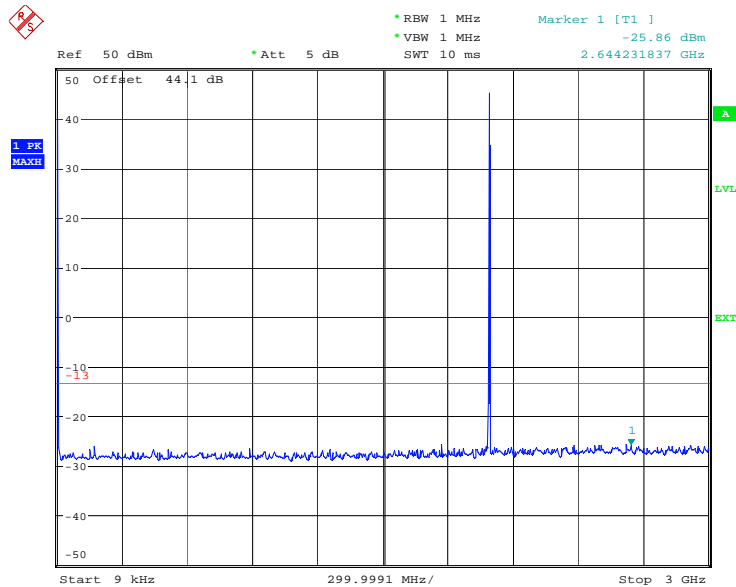

Date: 22.MAR.2011 09:26:07

Note: The emission beyond the limit is the operating frequency.

3GHz to 20GHz

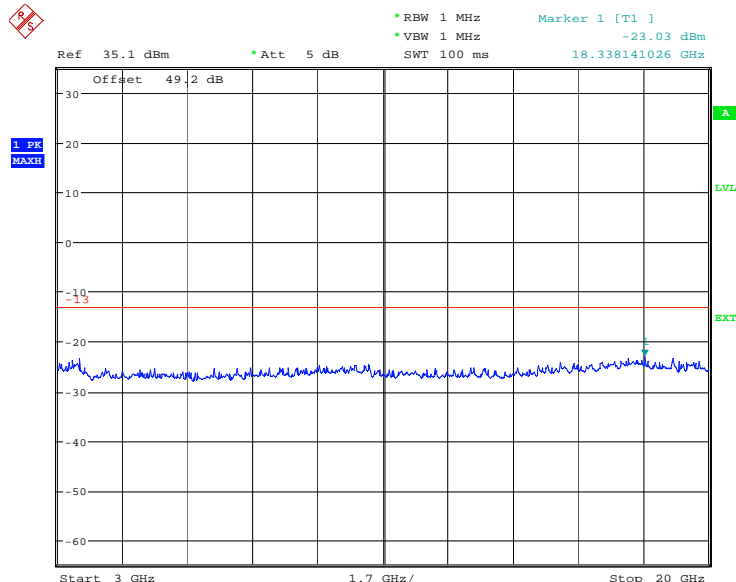

Date: 22.MAR.2011 09:27:21



Product Service

Limit	-13dBm
-------	--------

Remarks

The EUT does not exceed -13dBm at the frequency range of 9kHz to 25GHz.



Product Service

## **2.8 FREQUENCY STABILITY UNDER TEMPERATURE VARIATIONS**

### **2.8.1 Specification Reference**

FCC CFR 47 Part 2, Clause 2.1055  
FCC CFR 47 Part 24, Clause 24.235  
Industry Canada RSS-133, Clause 6.3

### **2.8.2 Equipment Under Test**

RUG 11 B2 / KRC 161 198/1, S/N: CB4G584762

### **2.8.3 Date of Test and Modification State**

23 March 2011 – Modification State 0

### **2.8.4 Test Equipment Used**

The major items of test equipment used for the above tests are identified in Section 3.1.

### **2.8.5 Test Method and Operating Modes**

The test was applied in accordance with the test method requirements of FCC CFR 47 Part 2 and Part 24 and Industry Canada RSS-133.

The EUT was set to transmit on maximum power. A Spectrum Analyser was used to measure the frequency error. The temperature was adjusted between -30°C and +50°C in 10° steps as per 2.1055.

The test was performed with the EUT in the following configurations and modes of operation:

Configuration 1 - Mode 2

### **2.8.6 Environmental Conditions**

	23 March 2011
Ambient Temperature	26.8°C
Relative Humidity	20.0%



## 2.8.7 Test Results

For the period of test the EUT met the requirements of FCC CFR 47 Part 2 and Part 24 and Industry Canada RSS-133 for Frequency Stability Under Temperature Variations.

The test results are shown below

Power Supply: -48V DC

### Configuration 1 - Mode 2

#### GMSK

Temperature Interval (°C)	Deviation (Hz)
-30	-4.08
-20	12.79
-10	-16.07
0	6.03
+10	-15.68
<b>+20</b>	<b>5.83</b>
+30	-5.14
+40	-11.30
+50	7.90

#### 8-PSK

Temperature Interval (°C)	Deviation (Hz)
-30	-9.54
-20	9.77
-10	-16.09
0	-5.01
+10	-14.09
<b>+20</b>	<b>-6.30</b>
+30	6.59
+40	-12.39
+50	7.46

16QAM

Temperature Interval (°C)	Deviation (Hz)
-30	-11.43
-20	12.79
-10	-18.46
0	-6.28
+10	-13.60
<b>+20</b>	<b>-6.20</b>
+30	-6.85
+40	-12.21
+50	9.14

32QAM

Temperature Interval (°C)	Deviation (Hz)
-30	-13.69
-20	-13.88
-10	-17.56
0	-8.71
+10	-15.34
<b>+20</b>	<b>-6.39</b>
+30	8.62
+40	-13.26
+50	7.66

Limit	±1.0 ppm or ±1.96kHz
-------	----------------------

Remarks

The frequency stability of the EUT is sufficient to keep it within the authorised frequency ranges at any temperature interval across the measured range.



Product Service

## **2.9 FREQUENCY STABILITY UNDER VOLTAGE VARIATIONS**

### **2.9.1 Specification Reference**

FCC CFR 47 Part 2, Clause 2.1055  
FCC CFR 47 Part 24, Clause 24.235  
Industry Canada RSS-133, Clause 6.3

### **2.9.2 Equipment Under Test**

RUG 11 B2 / KRC 161 198/1, S/N: CB4G584762

### **2.9.3 Date of Test and Modification State**

23 March 2011 – Modification State 0

### **2.9.4 Test Equipment Used**

The major items of test equipment used for the above tests are identified in Section 3.1.

### **2.9.5 Test Method and Operating Modes**

The test was applied in accordance with the test method requirements of FCC CFR 47 Part 2 and Part 24 and Industry Canada RSS-133.

The EUT was set to transmit on maximum power. A Spectrum Analyser was used to measure the frequency error. The supplied voltage was varied from 85 to 115 percent of the nominal value.

The test was performed with the EUT in the following configurations and modes of operation:

Configuration 1 - Mode 2

### **2.9.6 Environmental Conditions**

	23 March 2011
Ambient Temperature	26.8°C
Relative Humidity	20.0%





Product Service

**2.9.7 Test Results**

For the period of test the EUT met the requirements of FCC CFR 47 Part 2 and Part 24 and Industry Canada RSS-133 for Frequency Stability Under Voltage Variations.

The test results are shown below

Temperature: 20°C

**Configuration 1 - Mode 2**

**GMSK**

DC Voltage (V)	Deviation (Hz)
-40.8	5.35
<b>-48.0</b>	<b>5.83</b>
-55.2	6.12

**8-PSK**

DC Voltage (V)	Deviation (Hz)
-40.8	7.98
<b>-48.0</b>	<b>-6.30</b>
-55.2	8.50

**16QAM**

DC Voltage (V)	Deviation (Hz)
-40.8	8.56
<b>-48.0</b>	<b>-6.20</b>
-55.2	5.91

**32QAM**

DC Voltage (V)	Deviation (Hz)
-40.8	-6.29
<b>-48.0</b>	<b>-6.39</b>
-55.2	7.62

Limit	±1.0 ppm or ±1.96kHz
-------	----------------------

**Remarks**

The frequency stability of the EUT is sufficient to keep it within the authorised frequency ranges under voltage variations across the measured range.



Product Service

## 2.10 RECEIVER SPURIOUS EMISSIONS

### 2.10.1 Specification Reference

Industry Canada RSS-133, Clause 6.6

### 2.10.2 Equipment Under Test

RUG 11 B2 / KRC 161 198/1, S/N: CB4G584762

### 2.10.3 Date of Test and Modification State

22 March 2011 – Modification State 0

### 2.10.4 Test Equipment Used

The major items of test equipment used for the above tests are identified in Section 3.1.

### 2.10.5 Test Method and Operating Modes

The test was applied in accordance with the test method requirements of Industry Canada RSS-133.

In accordance with RSS-Gen Clause 6(b), the receiver spurious emissions from the antenna terminal were measured. Measurements were performed on the receiver antenna connector Ant B. The EUT was set to transmitter mode on the TX connector Ant A and during the measurement the Ant A was terminated with match load, (50 Ohm).

The resolution was set to 1MHz in the frequency range 9kHz to 10GHz thus meeting the requirements of RSS-Gen Clause 6(b), the spectrum analyser detector was set to peak and trace was kept on Max Hold to give the worst case. The limit line was displayed, showing the -57dBm, 2 nanowatts in band 9kHz to 1GHz and above 1GHz, -53dBm, 5 nanowatts.

The maximum path loss across the measurement band was used as the reference level offset to ensure worst case.

In addition, measurements were made from 9kHz up to the 5<sup>th</sup> harmonic of the fundamental.

The test was performed with the EUT in the following configurations and modes of operation as the worst cases:

Configuration 3 - Mode 2

### 2.10.6 Environmental Conditions

	22 March 2011
Ambient Temperature	26.2°C
Relative Humidity	20.4%



Product Service

### 2.10.7 Test Results

For the period of test the EUT met the requirements of Industry Canada RSS-133 for Receiver Spurious Emissions.

The test results are shown below

Remark:

The emissions at 9kHz on the plots was not generated by the test object. A complementary measruement with a smaller Span showed that it was related to the LO feedthrough.

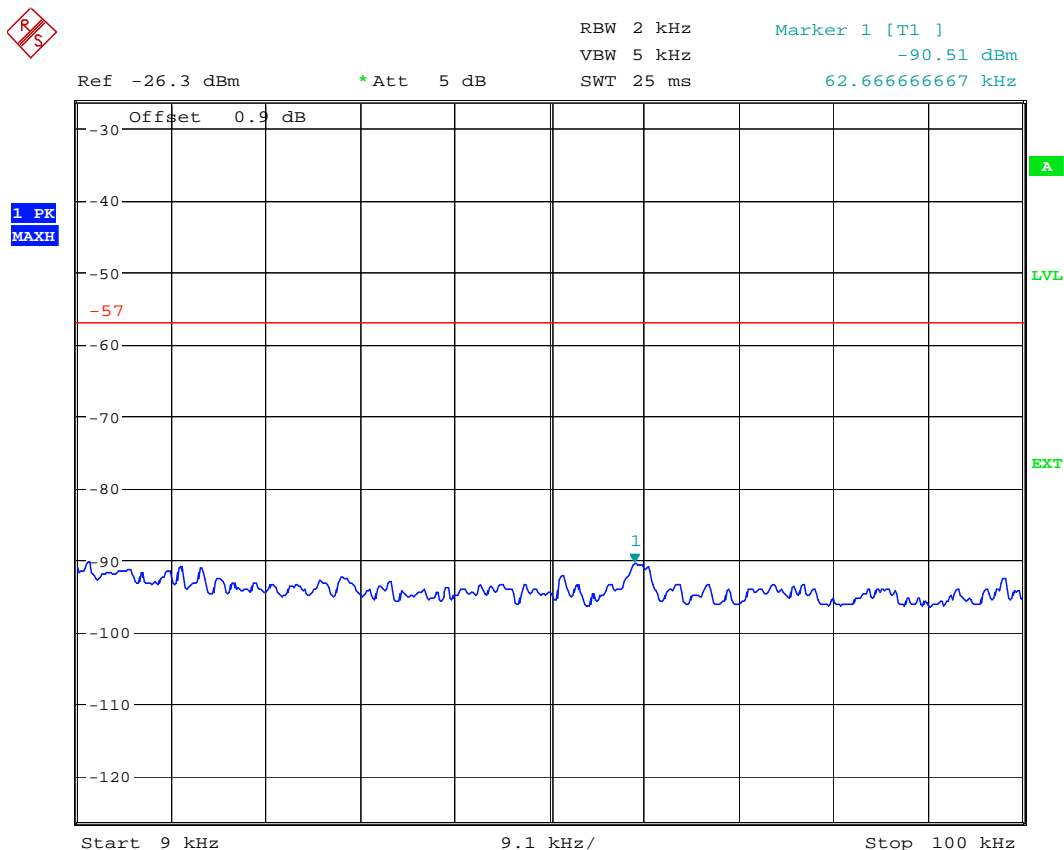

Date: 22.MAR.2011 13:15:35



Product Service

**Configuration 3 - Mode 2**

**GMSK**

**9kHz to 1GHz**

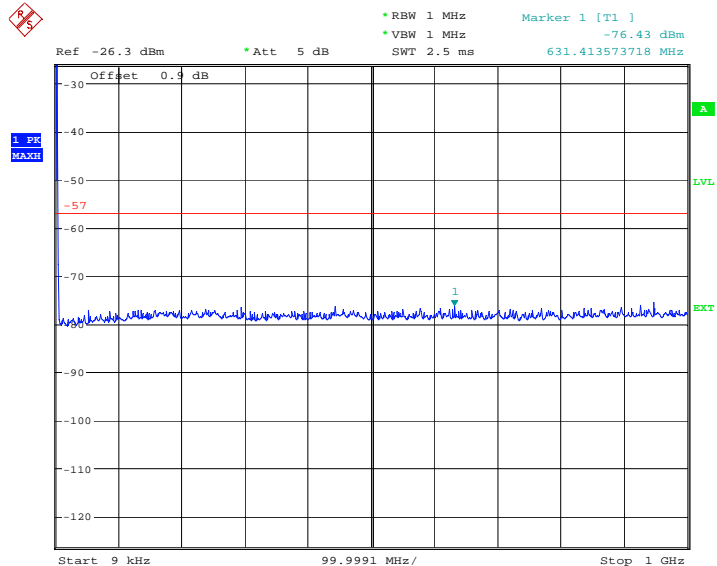

Date: 22.MAR.2011 13:14:37

**1GHz to 10GHz**

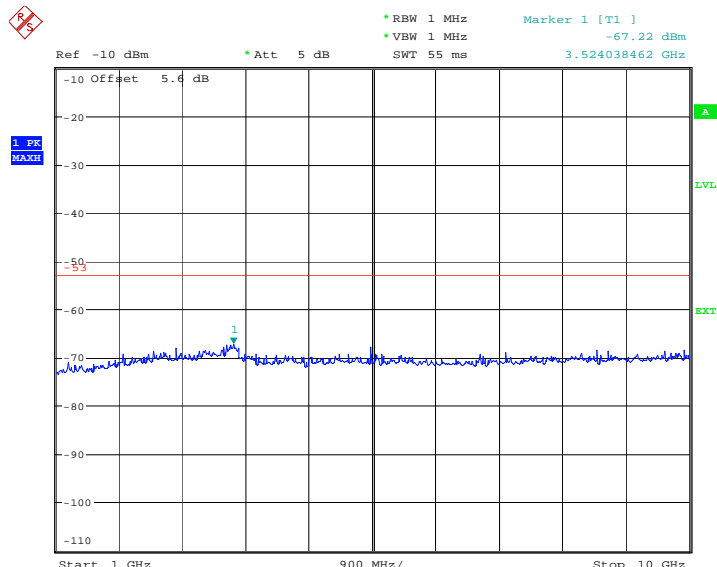

Date: 22.MAR.2011 13:17:25



Product Service

### 8-PSK

### 9kHz to 1GHz

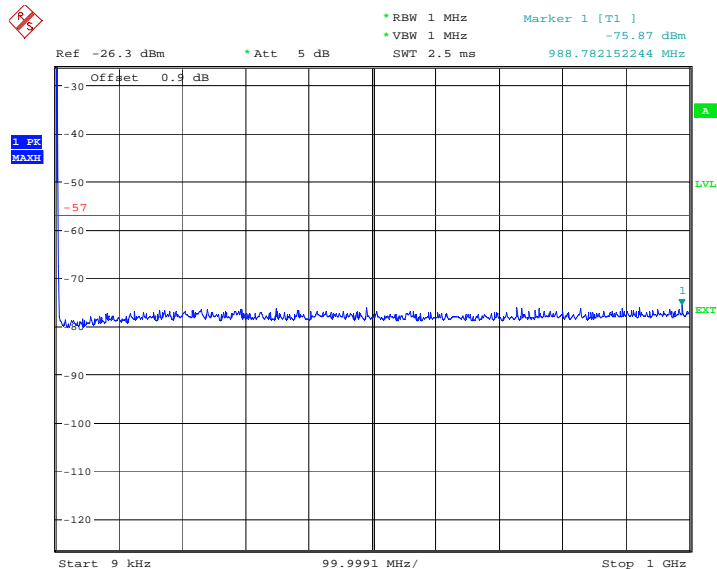

Date: 22.MAR.2011 13:13:47

### 1GHz to 10GHz

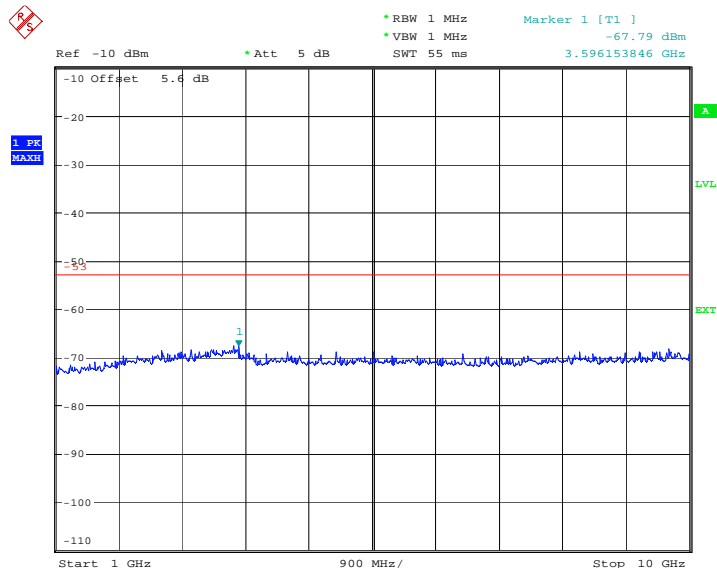

Date: 22.MAR.2011 13:18:06



16QAM

9kHz to 1GHz

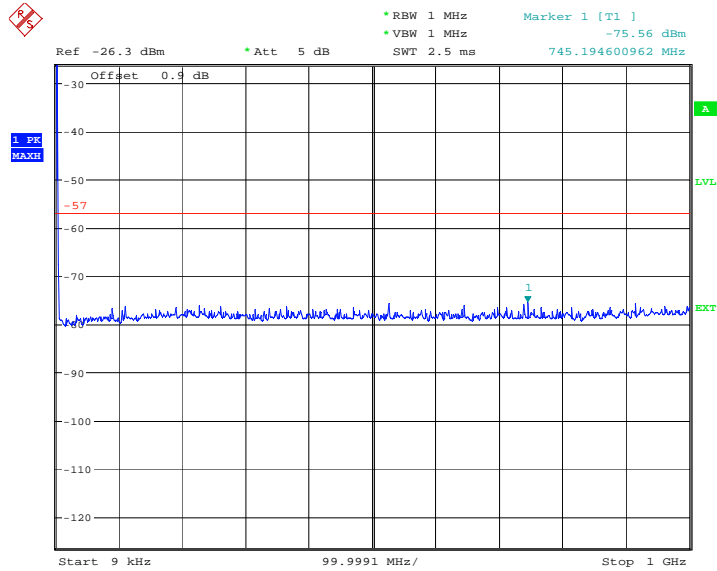

Date: 22.MAR.2011 13:12:52

1GHz to 10GHz

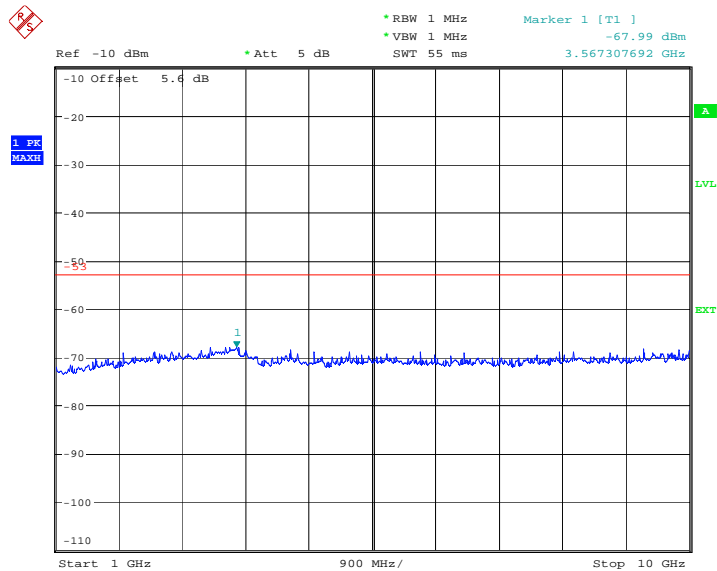

Date: 22.MAR.2011 13:18:44



**32QAM**

**9kHz to 1GHz**

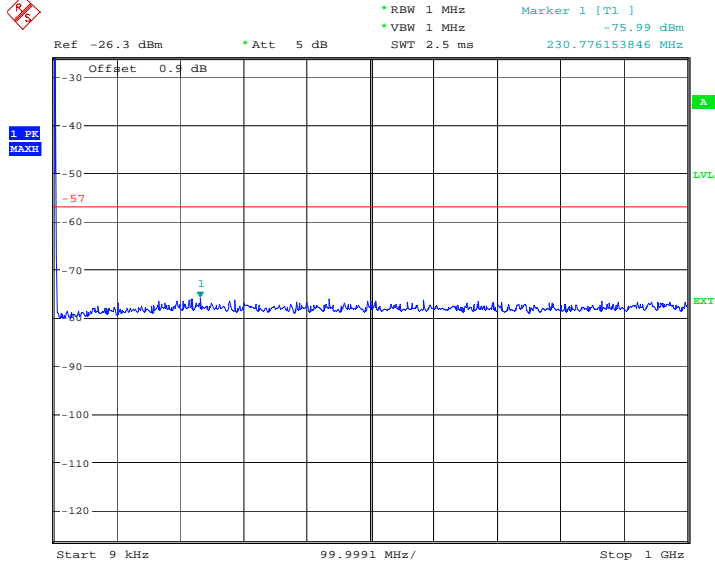

Date: 22.MAR.2011 13:11:23

**1GHz to 10GHz**

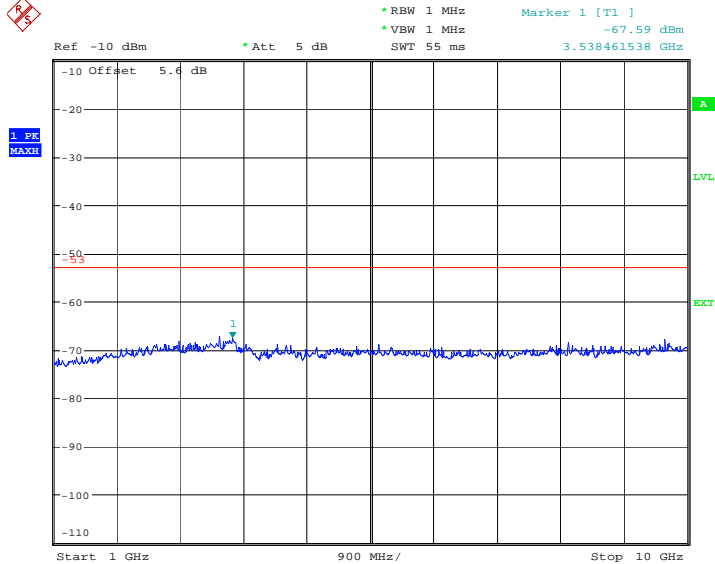

Date: 22.MAR.2011 13:19:19

Limit	-57dBm (30MHz-1GHz) and -53dBm (above 1GHz)
-------	---

**Remarks**

The EUT does not exceed -57dBm at the frequency range of 9kHz to 1GHz and does not exceed -53dBm at the frequency range of 1GHz to 10GHz.



Product Service

### **SECTION 3**

#### **TEST EQUIPMENT USED**





### 3.1 TEST EQUIPMENT USED

List of absolute measuring and other principal items of test equipment.

Instrument	Manufacturer	Type No.	Serial No.	Calibration Due
<b>Section 2.1, 2.2, 2.3, 2.4, 2.5, 2.7 and 2.10 – Maximum Conducted Output Power, Peak – Average Ratio, Modulation Characteristics, Occupied Bandwidth, Spurious Emissions at Antenna Terminals (<math>\pm 1</math>MHz), Conducted Spurious Emissions and Receiver Spurious Emissions.</b>				
Spectrum Analyser	Rohde & Schwarz	FSQ26	100244	24-Aug-2011
Singnal Analyser	Agilent	MXA N9020A	MY49100419	11-Apr-2012
Spectrum Analyser	Rohde & Schwarz	FSQ26	200761	24-Aug-2011
Power Metre	Rohde & Schwarz	NRP	102428	24-Aug-2011
Thermal Power Sensor	Rohde & Schwarz	NRP-Z21	102106	16-Feb-2012
Network Analyzer	Agilent	8720D	US38431317	24-Aug-2011
40dB Attenuator	Aeroflex / Weinschel	48-40-43-LIM	BR5020	O/P MON
Load	Shanghai Huaxiang	TF100	09121642	O/P MON
Power Supply	Dahua	DH1716-5D	2008040003	O/P MON
Power Supply	Dahua	DH1716A-10	1000303181	O/P MON
Digital Multi-meter	FLUKE	179	91820401	03-Jan-2012
Thermo-hygrometer	AZ Instruments	8705	9151655	24-Aug-2011
<b>Section 2.6 – Radiated Spurious Emissions</b>				
Load	Shanghai Huaxiang	TF100	09121642	O/P MON
Load	Shanghai Huaxiang	TF100	09121608	O/P MON
EMI Receiver	Rohde & Schwarz	ESI 40	100015	19-Aug-2011
Ultra log test antenna	Rohde & Schwarz	HL 562	100167	19-Aug-2011
Double-Ridged Waveguide Horn Antenna	Rohde & Schwarz	HF 906	100029	19-Aug-2011
Antenna master	Frankonia	MA 260	-	19-Aug-2011
Relay Switch Unit	Rohde & Schwarz	331.1601.31	338965002	N/A
Semi Anechoic Chamber	Frankonia	23.18m $\times$ 16.88m $\times$ 9.60m	-	19-Aug-2011
Power Supply	Dahua	DH1716-5D	2008040003	O/P MON
Digital Multimeter	FLUKE	179	91820401	03-Jan-2012
Thermo-hygrometer	AZ Instruments	8705	9151655	24-Aug-2011
<b>Section 2.8 and 2.9 – Frequency Stability Under Temperature and Voltage Variations</b>				
Spectrum Analyser	Rohde & Schwarz	FSQ26	200761	24-Aug-2011
20dB Attenuator	SHX	DTS100-20-3-A	090323444	O/P MON
20dB Attenuator	SHX	DTS80	090722015	O/P MON
Temperature Chamber	Zengda	ZTH030U	1009039	O/P MON
Power Supply	Dahua	DH1716-5D	2008040003	O/P MON
Power Supply	Dahua	DH1716A-10	1000303181	O/P MON
Digital Multimeter	FLUKE	179	91820401	03-Jan-2012

N/A – Not Applicable

O/P MON - Output monitored with calibration equipment



Product Service

### 3.2 MEASUREMENT UNCERTAINTY

For a 95% confidence level, the measurement uncertainties for defined systems are:-

Test Discipline	Frequency / Parameter	MU
Conducted Maximum Peak Output Power	30MHz to 10GHz Amplitude	0.5dB*
Conducted Emissions	30MHz to 40GHz Amplitude	3.0dB*
Frequency Stability	30MHz to 2GHz Amplitude	<1x10 <sup>-7</sup>
Radiated Emissions, Bilog Antenna, AOATS	30MHz to 1GHz Amplitude	5.1dB*
Radiated Emissions, Horn Antenna, AOATS	1GHz to 40GHz Amplitude	6.3dB*
Worst case error for both Time and Frequency measurement 12 parts in 10 <sup>6</sup>		

\* In accordance with CISPR 16-4



Product Service

## **SECTION 4**

### **ACCREDITATION, DISCLAIMERS AND COPYRIGHT**



Product Service

#### 4.1 ACCREDITATION, DISCLAIMERS AND COPYRIGHT



This report relates only to the actual item/items tested.

Our UKAS Accreditation does not cover opinions and interpretations and any expressed are outside the scope of our UKAS Accreditation.

Results of tests not covered by our UKAS Accreditation Schedule are marked NUA  
(Not UKAS Accredited).

This report must not be reproduced, except in its entirety, without the written permission of  
TÜV SÜD Product Service Limited

© 2011 TÜV SÜD Product Service Limited