



Product Service

**Choose certainty.
Add value.**

Report On

FCC and Industry Canada Testing of the
Ericsson AB RRUS 01 B2 / KRC 118 74/2

COMMERCIAL-IN-CONFIDENCE

FCC ID: TA8AKRC11874-2

IC ID: 287AB-AS118742

Document 75921090 Report 01 Issue 1

March 2013



Product Service

TÜV SÜD Product Service, Octagon House, Concorde Way, Segensworth North,
Fareham, Hampshire, United Kingdom, PO15 5RL
Tel: +44 (0) 1489 558100. Website: www.tuv-sud.co.uk

COMMERCIAL-IN-CONFIDENCE

REPORT ON

FCC and Industry Canada Testing of the
Ericsson RRUS 01 B2 / KRC 118 74/2

Document 75921090 Report 01 Issue 1

March 2013

PREPARED FOR

Ericsson AB
Torshamnsgatan 10
SE-164 80
Stockholm
Sweden

PREPARED BY



X Zhang
Test Engineer

APPROVED BY



M Jenkins
Authorised Signatory

DATED

28 March 2013

ENGINEERING STATEMENT

The measurements shown in this report were made in accordance with the procedures described on test pages. All reported testing was carried out on a sample equipment to demonstrate compliance with FCC CFR 47: Part 24 and Industry Canada RSS-133. The sample tested was found to comply with the requirements defined in the applied rules.

Test Engineer(s);

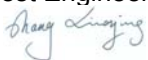

X Zhang



C Zhang





CONTENTS

Section	Page No
1	REPORT SUMMARY 3
1.1	Introduction 4
1.2	Brief Summary of Results 5
1.3	Declaration of Build Status 9
1.4	Product Information 10
1.5	Test Conditions 15
1.6	Deviations From the Standard 15
1.7	Modification Record 15
1.8	Alternative Test Site 15
2	TEST DETAILS 16
2.1	Maximum Peak Output Power - Conducted 17
2.2	Peak – average ratio 25
2.3	Modulation Characteristics 57
2.4	Occupied Bandwidth 61
2.5	Spurious Emissions at Antenna Terminals (± 1 MHz) 65
2.6	Radiated Spurious Emissions 86
2.7	Conducted Spurious Emissions 92
3	TEST EQUIPMENT USED 120
3.1	Test Equipment Used 121
3.2	Measurement Uncertainty 122
4	ACCREDITATION, DISCLAIMERS AND COPYRIGHT 123
4.1	Accreditation, Disclaimers and Copyright 124



SECTION 1

REPORT SUMMARY

FCC and Industry Canada Testing of the
Ericsson RRUS 01 B2 / KRC 118 74/2



1.1 INTRODUCTION

The information contained in this report is intended to show verification of the Ericsson RRUS 01 B2 / KRC 118 74/2 to the requirements of FCC CFR 47 Part 24 and Industry Canada RSS-133.

Testing was carried out in support of a C2PC application for Grant of RRUS 01 B2 / KRC 118 74/2 for hardware update.

Objective	To perform FCC and Industry Canada Testing to determine the Equipment Under Test's (EUT's) compliance with the Test Specification, for the series of tests carried out.
Manufacturer	Ericsson AB
Product Name	RRUS 01 B2
Product Number	KRC 118 74/2
IC Model Number	AS118742
Serial Number(s)	D162554351
Software Version	CXP 104 0013/09 Rev R71H
PIS Software Version	CXP 901 7316/1 Rev R39UL
Hardware Version	R1F
Number of Samples Tested	1
Test Specification/Issue/Date	FCC CFR 47 Part 24: 2012 Industry Canada RSS-133 Issue 6: 2013
Incoming Release Date	Declaration of Build Status 24 February 2013
Order Number Date	PTP 13 December 2012
Start of Test	25 February 2013
Finish of Test	25 March 2013
Name of Engineer(s)	X Zhang C Zhang
Related Document(s)	ANSI C63.4: 2009 FCC CFR 47 Part 2: 2012 Industry Canada RSS-GEN Issue 3: 2010



1.2 BRIEF SUMMARY OF RESULTS

A brief summary of results in accordance with FCC CFR 47 Part 24 and Industry Canada RSS-133, is shown below.

Configuration 1 – Radio Equipment							
Section	Spec Clause		Test Description	Mode	Mod State	Result	Comments
	FCC Part 2 and 24	RSS-133 and RSS-GEN					
	24.232 (a)	6.4	Effective Radiated Power	1930.4MHz*		N/A	No integral antenna.
				1960.0MHz		N/A	
				1989.6MHz*		N/A	
				1930.4MHz* + 1950.2MHz		N/A	
				1960.0MHz + 1979.8MHz		N/A	
				1969.8MHz + 1989.6MHz*		N/A	
				1930.4MHz* + 1935.2MHz + 1940.2MHz		N/A	
				1955.2MHz + 1960.0MHz + 1965.0MHz		N/A	
				1979.8MHz + 1984.8MHz + 1989.6MHz*		N/A	
				1930.4MHz* + 1933.6MHz + 1936.8MHz + 1940.2MHz		N/A	
				1956.8MHz + 1960.0MHz + 1963.2MHz + 1966.6MHz		N/A	
				1979.8MHz + 1983.2MHz + 1986.4MHz + 1989.6MHz*		N/A	
2.1	2.1046, 24.232 (a)	6.4	Maximum Peak Output Power - Conducted	1930.4MHz*	0	Pass	-
				1960.0MHz	0	Pass	
				1989.6MHz*	0	Pass	
				1930.4MHz* + 1950.2MHz	0	Pass	
				1960.0MHz + 1979.8MHz	0	Pass	
				1969.8MHz + 1989.6MHz*	0	Pass	
				1930.4MHz* + 1935.2MHz + 1940.2MHz	0	Pass	
				1955.2MHz + 1960.0MHz + 1965.0MHz	0	Pass	
				1979.8MHz + 1984.8MHz + 1989.6MHz*	0	Pass	
				1930.4MHz* + 1933.6MHz + 1936.8MHz + 1940.2MHz	0	Pass	
				1956.8MHz + 1960.0MHz + 1963.2MHz + 1966.6MHz	0	Pass	
				1979.8MHz + 1983.2MHz + 1986.4MHz + 1989.6MHz*	0	Pass	



2.2	24.232 (d)	6.4	Peak – Average Ratio	1930.4MHz*	0	Pass	-
				1960.0MHz	0	Pass	
				1989.6MHz*	0	Pass	
				1930.4MHz* + 1950.2MHz	0	Pass	
				1960.0MHz + 1979.8MHz	0	Pass	
				1969.8MHz + 1989.6MHz*	0	Pass	
				1930.4MHz* + 1935.2MHz + 1940.2MHz	0	Pass	
				1955.2MHz + 1960.0MHz + 1965.0MHz	0	Pass	
				1979.8MHz + 1984.8MHz + 1989.6MHz*	0	Pass	
				1930.4MHz* + 1933.6MHz + 1936.8MHz + 1940.2MHz	0	Pass	
				1956.8MHz + 1960.0MHz + 1963.2MHz + 1966.6MHz	0	Pass	
				1979.8MHz + 1983.2MHz + 1986.4MHz + 1989.6MHz*	0	Pass	
2.3	2.1047 (d)	6.2	Modulation Characteristics	1930.4MHz*		N/A	-
				1960.0MHz	0	Pass	
				1989.6MHz*		N/A	
				1930.4MHz* + 1950.2MHz		N/A	
				1960.0MHz + 1979.8MHz		N/A	
				1969.8MHz + 1989.6MHz*		N/A	
				1930.4MHz* + 1935.2MHz + 1940.2MHz		N/A	
				1955.2MHz + 1960.0MHz + 1965.0MHz		N/A	
				1979.8MHz + 1984.8MHz + 1989.6MHz*		N/A	
				1930.4MHz* + 1933.6MHz + 1936.8MHz + 1940.2MHz		N/A	
				1956.8MHz + 1960.0MHz + 1963.2MHz + 1966.6MHz		N/A	
				1979.8MHz + 1983.2MHz + 1986.4MHz + 1989.6MHz*		N/A	
2.4	2.1049, 24.238 (b)	RSS-Gen 4.6.1	Occupied Bandwidth	1930.4MHz*		N/A	-
				1960.0MHz		N/A	
				1989.6MHz*		N/A	
				1930.4MHz* + 1950.2MHz		N/A	
				1960.0MHz + 1979.8MHz	0	Pass	
				1969.8MHz + 1989.6MHz*		N/A	
				1930.4MHz* + 1935.2MHz + 1940.2MHz		N/A	
				1955.2MHz + 1960.0MHz + 1965.0MHz		N/A	
				1979.8MHz + 1984.8MHz + 1989.6MHz*		N/A	
				1930.4MHz* + 1933.6MHz + 1936.8MHz + 1940.2MHz		N/A	
				1956.8MHz + 1960.0MHz + 1963.2MHz + 1966.6MHz		N/A	
				1979.8MHz + 1983.2MHz + 1986.4MHz + 1989.6MHz*		N/A	



2.5	2.1051, 24.238 (b)	6.5	Spurious Emissions at Antenna Terminals (± 1 MHz)	1930.4MHz*	0	Pass	-
				1960.0MHz		N/A	
				1989.6MHz*	0	Pass	
				1930.4MHz* + 1932.0MHz	0	Pass	
				1960.0MHz + 1961.6MHz		N/A	
				1988.0MHz + 1989.6MHz*	0	Pass	
				1930.4MHz* + 1932.0MHz + 1933.6MHz	0	Pass	
				1955.2MHz + 1960.0MHz + 1965.0MHz		N/A	
				1986.4MHz + 1988.0MHz + 1989.6MHz*	0	Pass	
				1930.4MHz* + 1933.6MHz + 1936.8MHz + 1940.2MHz	0	Pass	
				1956.8MHz + 1960.0MHz + 1963.2MHz + 1966.6MHz		N/A	
				1979.8MHz + 1983.2MHz + 1986.4MHz + 1989.6MHz*	0	Pass	
2.6	2.1053, 24.238 (a)	6.5	Radiated Spurious Emissions	1930.4MHz*		N/A	-
				1960.0MHz	0	Pass	
				1989.6MHz*		N/A	
				1930.4MHz* + 1950.2MHz	0	Pass	
				1960.0MHz + 1979.8MHz	0	Pass	
				1969.8MHz + 1989.6MHz*	0	Pass	
				1930.4MHz* + 1935.2MHz + 1940.2MHz		N/A	
				1955.2MHz + 1960.0MHz + 1965.0MHz		N/A	
				1979.8MHz + 1984.8MHz + 1989.6MHz*		N/A	
				1930.4MHz* + 1933.6MHz + 1936.8MHz + 1940.2MHz		N/A	
				1956.8MHz + 1960.0MHz + 1963.2MHz + 1966.6MHz	0	Pass	
				1979.8MHz + 1983.2MHz + 1986.4MHz + 1989.6MHz*		N/A	
2.7	2.1051, 24.238 (a)	6.5	Conducted Spurious Emissions	1930.4MHz*	0	Pass	-
				1960.0MHz	0	Pass	
				1989.6MHz*	0	Pass	
				1930.4MHz* + 1950.2MHz		N/A	
				1960.0MHz + 1979.8MHz		N/A	
				1969.8MHz + 1989.6MHz*		N/A	
				1930.4MHz* + 1935.2MHz + 1940.2MHz	0	Pass	
				1955.2MHz + 1960.0MHz + 1965.0MHz	0	Pass	
				1979.8MHz + 1984.8MHz + 1989.6MHz*	0	Pass	
				1930.4MHz* + 1933.6MHz + 1936.8MHz + 1940.2MHz	0	Pass	
				1956.8MHz + 1960.0MHz + 1963.2MHz + 1966.6MHz	0	Pass	
				1979.8MHz + 1983.2MHz + 1986.4MHz + 1989.6MHz*	0	Pass	



	2.1055, 24.235	6.3	Frequency Stability Under Temperature Variations	1930.4MHz*	N/A	-
				1960.0MHz	N/A	
				1989.6MHz*	N/A	
				1930.4MHz* + 1950.2MHz	N/A	
				1960.0MHz + 1979.8MHz	N/A	
				1969.8MHz + 1989.6MHz*	N/A	
				1930.4MHz* + 1935.2MHz + 1940.2MHz	N/A	
				1955.2MHz + 1960.0MHz + 1965.0MHz	N/A	
				1979.8MHz + 1984.8MHz + 1989.6MHz*	N/A	
				1930.4MHz* + 1933.6MHz + 1936.8MHz + 1940.2MHz	N/A	
				1956.8MHz + 1960.0MHz + 1963.2MHz + 1966.6MHz	N/A	
				1979.8MHz + 1983.2MHz + 1986.4MHz + 1989.6MHz*	N/A	
	2.1055, 24.235	6.3	Frequency Stability Under Voltage Variations	1930.4MHz*	N/A	-
				1960.0MHz	N/A	
				1989.6MHz*	N/A	
				1930.4MHz* + 1950.2MHz	N/A	
				1960.0MHz + 1979.8MHz	N/A	
				1969.8MHz + 1989.6MHz*	N/A	
				1930.4MHz* + 1935.2MHz + 1940.2MHz	N/A	
				1955.2MHz + 1960.0MHz + 1965.0MHz	N/A	
				1979.8MHz + 1984.8MHz + 1989.6MHz*	N/A	
				1930.4MHz* + 1933.6MHz + 1936.8MHz + 1940.2MHz	N/A	
				1956.8MHz + 1960.0MHz + 1963.2MHz + 1966.6MHz	N/A	
				1979.8MHz + 1983.2MHz + 1986.4MHz + 1989.6MHz*	N/A	

Note*: The channel adjacent to the lower and higher band-edge cannot be used. The lowest usable channel is 513 (1930.4MHz), the highest usable channel is 809 (1989.6MHz)

N/A – Not Applicable



1.3 DECLARATION OF BUILD STATUS

MAIN EUT						
MANUFACTURING DESCRIPTION	Radio Equipment					
MANUFACTURER	Ericsson AB					
PRODUCT NUMBER	RRUS 01 B2					
PART NUMBER	KRC 118 74/2					
IC Model NUMBER	AS118742					
SERIAL NUMBER	D162554351					
HARDWARE VERSION	R1F					
SOFTWARE VERSION	CXP 104 0013/09 Rev R71H					
PIS SOFTWARE VERSION	CXP 901 7316/1 Rev R39UL					
TRANSMITTER OPERATING RANGE	TX: 1930.4MHz - 1989.6MHz RX: 1850.4MHz - 1909.6MHz					
MODULATIONS	GMSK, 8-PSK, 16QAM, 32QAM, AQPSK					
INTERMEDIATE FREQUENCIES	--					
ITU DESIGNATION OF EMISSION	250KGXW 250KG7W					
OUTPUT POWER (RMS) (W or dBm)		GMSK	8-PSK	16QAM	32QAM	AQPSK
	Single Carrier:	1x47.8dBm (1x60W)				
	Multi Carrier (1x2):	2x44.8dBm (2x30.0W)	2x44.8dBm (2x30.0W)	2x44.6dBm (2x28.8W)	2x44.2dBm (2x26.3W)	2x44.8dBm (2x30.0W)
	Multi Carrier (1x3):	3x44.3dBm (3x26.9W)	3x42.6dBm (3x18.2W)	3x41.2dBm (3x13.2W)	3x40.8dBm (3x12.0W)	3x42.5dBm (3x17.8W)
	Multi Carrier (1x4):	4x43.0dBm (4 x20.0W)	4x40.2dBm (4 x10.5W)	4x38.8dBm (4 x 7.6W)	4x38.4dBm (4 x6.9W)	4x40.1dBm (4 x10.2W)
OUTPUT POWER TOLERANCE	± 1dB					
NUMBER OF ANTENNA PORTS	1 TX/ RX and 1 RX ports					
FCC ID	TA8AKRC11874-2					
IC ID	287AB-AS118742					
TECHNICAL DESCRIPTION (a brief description of the intended use and operation)	The equipment is the Radio Part of GSM Base Station.					

Signature

Date

15 March 2013

D of B S Serial No

75921090/01

No responsibility will be accepted by TÜV SÜD Product Service as to the accuracy of the information declared in this document by the manufacturer.



1.4 PRODUCT INFORMATION

1.4.1 Technical Description

The Equipment Under Test (EUT) RRUS 01 B2 / KRC 118 74/2 is an Ericsson Radio Equipment working in the public mobile service 1900MHz band which provides communication connections to GSM1900 network. The RRUS 01 B2 / KRC 118 74/2 operates from a - 48V DC supply.

The Equipment Under Test (EUT) is shown in the photograph below. A full technical description can be found in the Manufacturers documentation.



Equipment Under Test



Product Service

1.4.2 Test Configuration

Configuration 1: Radio Equipment

The EUT was configured in accordance with FCC CFR 47 Part 24 and Industry Canada RSS-133.

The RRUS 01 B2 / KRC 118 74/2 supports GMSK, 8-PSK, 16QAM, 32QAM and AQPSK modulations at 1900MHz. The EUT includes a TX/RX port and a RX port. It can be configured to transmit with 1900MHz single or multi carrier at the RF output connector. All TX measurements were performed on the combined TX/RX output connector RF A of the EUT, with RX antenna port RF B terminated.

The settings below were found to be representative for all modes when several settings with the different modulations were tested to find the worst case setting. The settings were used for all measurements if not otherwise noted:

- Single Carrier: GMSK and 8-PSK modulations

The complete testing was performed with the EUT transmitting at maximum RF power unless otherwise stated. For AQPSK modulation, the SCPIR is 0dB.

The EUT was powered by a -48V DC Power supply.



Test Setup, Conducted Measurement:

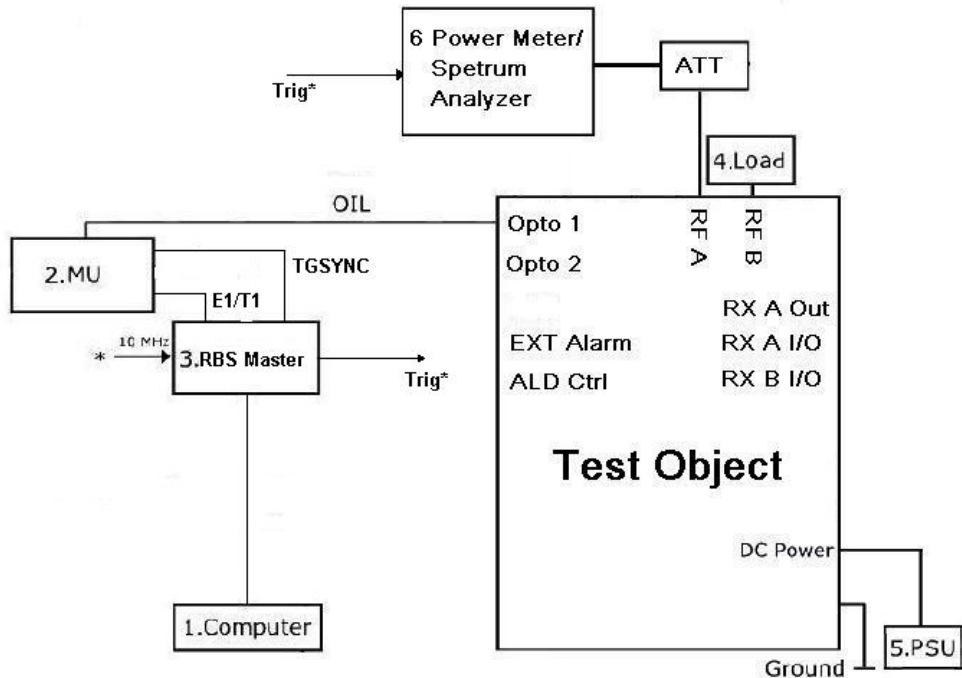

Product Name	Product Number	Version	Serial Number
RRUS 01 B2	KRC 118 74/2	R1F	D162554351

No.	Auxiliary Equipment	Part Number / Model Type	Version	Serial Number
1	Computer	HP EliteBook 8530w	--	2CE0130ZG1
2	RBS 6601	BFL 901 009/1	--	--
	DUG 20 01	KDU 137 569/1	R2B	C823856106
	SUP 6601	1/BFL 901 009/1	R1E	BR82322420
3	RBS Master	LPY 107 1007/3	R1C	T01E050944
4	Load	TF100	--	09121602
5	Power Supply	DH1716A-14	--	20080406
6	Power Meter	Rohde & Schwarz NRP	--	101283
	Power Sensor	Rohde & Schwarz NRP-Z21	--	102106
	Spectrum Analyzer	FSQ26	--	200014
	Spectrum Analyzer	FSQ26	--	201123



Test Setup, Radiated Measurement:

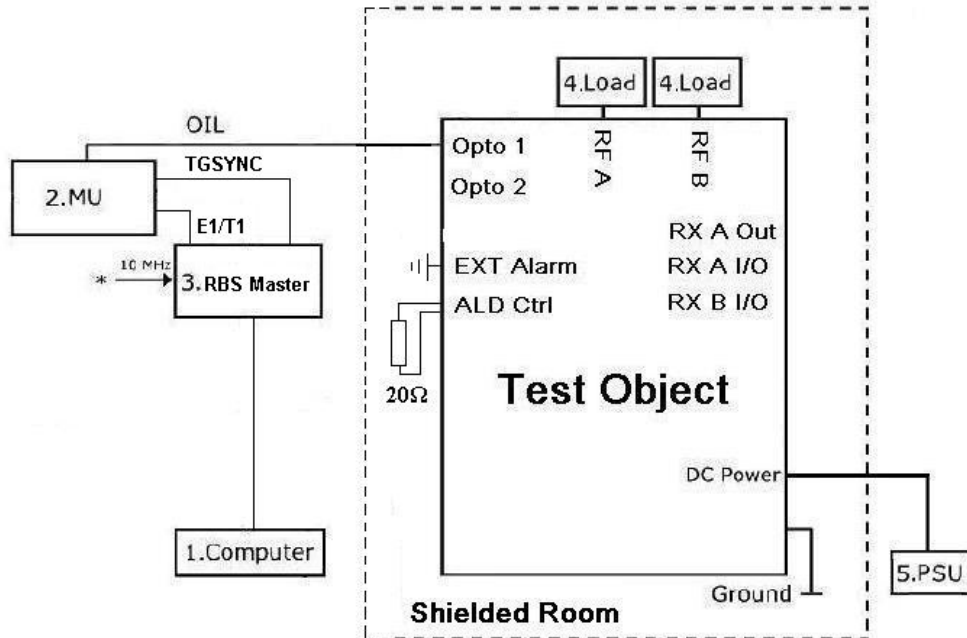

Product Name	Product Number	Version	Serial Number
RRUS 01 B2	KRC 118 74/2	R1F	D162554351

No.	Auxiliary Equipment	Part Number / Model Type	Version	Serial Number
1	Computer	HP EliteBook 8530w	--	2CE0130ZG1
2	RBS 6601	BFL 901 009/1	--	--
	DUG 20 01	KDU 137 569/1	R2B	C823856106
	SUP 6601	1/BFL 901 009/1	R1E	BR82322420
3	RBS Master	LPY 107 1007/3	R1C	T01E050944
4	Load	TFZ50C-3FR	--	JW8042-04A-021
	Load	TFE100	--	09121602
5	Power Supply	DH1716A-14	--	20080406



1.4.3 Modes of Operation

Modes of operation of each EUT during testing were as follows:

Mode 1 – ARFCN 513: 1930.4MHz (Bottom Channel)

Mode 2 – ARFCN 661: 1960.0MHz (Middle Channel)

Mode 3 – ARFCN 809: 1989.6MHz (Top Channel)

Mode 4 – ARFCN 513 + 612: 1930.4MHz + 1950.2MHz (B Ch and B Ch + 19.8MHz)

Mode 5 – ARFCN 661 + 760: 1960.0MHz + 1979.8MHz (M Ch and M Ch + 19.8MHz)

Mode 6 – ARFCN 710 + 809: 1969.8MHz + 1989.6MHz (T Ch - 19.8MHz and T Ch)

Mode 4' – ARFCN 513 + 521: 1930.4MHz + 1932.0MHz (B Ch and B + 8 Ch)

Mode 6' – ARFCN 801 + 809: 1988.0MHz + 1989.6MHz (T - 8 Ch and T Ch)

Mode 7 – ARFCN 513 + 537 + 562:
1930.4MHz + 1935.2MHz + 1940.2MHz (B Ch, B Ch + 4.8MHz and B Ch + 9.8MHz)

Mode 8 – ARFCN 637 + 661 + 686:
1955.2MHz + 1960.0MHz + 1965.0MHz (M Ch - 4.8MHz, M Ch and M Ch + 9.8MHz)

Mode 9 – ARFCN 760 + 785 + 809:
1979.8MHz + 1984.8MHz + 1989.6MHz (T Ch - 9.8MHz, T Ch - 4.8MHz and T Ch)

Mode 7' – ARFCN 513 + 521 + 529:
1930.4MHz + 1932.0MHz + 1933.6MHz (B Ch, B + 8 Ch and B + 16 Ch)

Mode 9' – ARFCN 793 + 801 + 809:
1986.4MHz + 1988.0MHz + 1989.6MHz (T - 16 Ch, T - 8 Ch and T Ch)

Mode 10 – ARFCN 513 + 529 + 545 + 562:
1930.4MHz + 1933.6MHz + 1936.8MHz + 1940.2MHz
(B Ch, B Ch + 3.2MHz, B Ch + 6.4MHz and B Ch + 9.8MHz)

Mode 11 - ARFCN 645 + 661 + 677 + 694:
1956.8MHz + 1960.0MHz + 1963.2MHz + 1966.6MHz
(M Ch - 3.2MHz, M Ch, M Ch + 3.2MHz and M Ch + 6.6MHz)

Mode 12 - ARFCN 760 + 777 + 793 + 809:
1979.8MHz + 1983.2MHz + 1986.4MHz + 1989.6MHz
(T Ch - 9.8MHz, T Ch - 6.4MHz, T Ch - 3.2MHz and T Ch)

Information on the specific test modes utilised are detailed in the test procedure for each individual test.



Product Service

1.5 TEST CONDITIONS

For all tests the EUT was set up in accordance with the relevant test standard and to represent typical operating conditions. Tests were applied with the EUT situated in a shielded enclosure, test laboratories or an open test area as appropriate.

The EUT was powered from a -48V DC supply.

1.6 DEVIATIONS FROM THE STANDARD

No deviations from the applicable test standards or test plan were made during testing.

1.7 MODIFICATION RECORD

No modifications were made to the EUT during testing.

1.8 ALTERNATIVE TEST SITE

Only Radiated Spurious Emissions testing has been performed under the following site registrations:

FCC Accreditation 910917:

The State Radio Monitoring Centre, No.80 Beilishi Road Xicheng District Beijing, China.

Industry Canada Accreditation 7308A-1:

The State Radio Monitoring Centre, No.80 Beilishi Road Xicheng District Beijing, China.



Product Service

SECTION 2

TEST DETAILS

FCC and Industry Canada Testing of the
Ericsson RRUS 01 B2 / KRC 118 74/2



Product Service

2.1 MAXIMUM PEAK OUTPUT POWER - CONDUCTED

2.1.1 Specification Reference

FCC CFR 47 Part 2, Clause 2.1046
FCC CFR 47 Part 24, Clause 24.232 (a)
Industry Canada RSS-133, Clause 6.4

2.1.2 Equipment Under Test

RRUS 01 B2 / KRC 118 74/2, S/N: D162554351

2.1.3 Date of Test and Modification State

25 to 27 February and 25 March 2013 – Modification State 0

2.1.4 Test Equipment Used

The major items of test equipment used for the above tests are identified in Section 3.1.

2.1.5 Test Method and Operating Modes

The test was applied in accordance with the test method requirements of FCC CFR 47 Part 2 and Part 24 and Industry Canada RSS-133.

Using a power meter and attenuator(s), the output power of the EUT was measured at the antenna terminal. The carrier power was measured with GMSK, 8-PSK, 16QAM, 32QAM and AQPSK modulations.

The path loss was measured and entered as a reference level offset.

The test was performed with the EUT in the following configurations and modes of operation:

Configuration 1 - Mode 1
- Mode 2
- Mode 3
- Mode 4
- Mode 5
- Mode 6
- Mode 7
- Mode 8
- Mode 9
- Mode 10
- Mode 11
- Mode 12



2.1.6 Environmental Conditions

	25 Feb. 2013	26 Feb. 2013	27 Feb. 2013	25 Mar. 2013
Ambient Temperature	20.5 °C	20.7 °C	21.0 °C	20.8 °C
Relative Humidity	24.0%	24.0%	20.2%	23.5%

2.1.7 Test Results

For the period of test the EUT met the requirements of FCC CFR 47 Part 2 and Part 24 and Industry Canada RSS-133 for Maximum Peak Output Power.

The test results are shown below

Single Carrier

Configuration 1 - Mode 1, 2 and 3

GMSK

ARFCN	Frequency (MHz)	Path Loss (dB)	Result (dBm) RMS	Result (W) RMS
513	1930.4	41.3	47.68	58.61
661	1960.0	41.3	47.58	57.28
809	1989.6	41.3	47.48	55.98

8-PSK

ARFCN	Frequency (MHz)	Path Loss (dB)	Result (dBm) RMS	Result (W) RMS
513	1930.4	41.3	47.63	57.94
661	1960.0	41.3	47.57	57.15
809	1989.6	41.3	47.46	55.72

16QAM

ARFCN	Frequency (MHz)	Path Loss (dB)	Result (dBm) RMS	Result (W) RMS
513	1930.4	41.3	47.55	56.89
661	1960.0	41.3	47.45	55.59
809	1989.6	41.3	47.35	54.33

32QAM

ARFCN	Frequency (MHz)	Path Loss (dB)	Result (dBm) RMS	Result (W) RMS
513	1930.4	41.3	47.48	55.98
661	1960.0	41.3	47.42	55.21
809	1989.6	41.3	47.30	53.70

AQPSK

ARFCN	Frequency (MHz)	Path Loss (dB)	Result (dBm) RMS	Result (W) RMS
513	1930.4	41.3	47.58	57.28
661	1960.0	41.3	47.51	56.36
809	1989.6	41.3	47.41	55.08

**Multi Carrier (1x2)**Configuration 1 - Mode 4, 5 and 6GMSK

ARFCN	Frequency (MHz)	Path Loss (dB)	Result (dBm) RMS	Result (W) RMS
513 + 612	1930.4 + 1950.2	41.3	47.50	56.23
661 + 760	1960.0 + 1979.8	41.3	47.47	55.85
710 + 809	1969.8 + 1989.6	41.3	47.43	55.34

8-PSK

ARFCN	Frequency (MHz)	Path Loss (dB)	Result (dBm) RMS	Result (W) RMS
513 + 612	1930.4 + 1950.2	41.3	47.48	55.98
661 + 760	1960.0 + 1979.8	41.3	47.48	55.98
710 + 809	1969.8 + 1989.6	41.3	47.48	55.98

16QAM

ARFCN	Frequency (MHz)	Path Loss (dB)	Result (dBm) RMS	Result (W) RMS
513 + 612	1930.4 + 1950.2	41.3	47.38	54.70
661 + 760	1960.0 + 1979.8	41.3	47.40	54.95
710 + 809	1969.8 + 1989.6	41.3	47.38	54.70

32QAM

ARFCN	Frequency (MHz)	Path Loss (dB)	Result (dBm) RMS	Result (W) RMS
513 + 612	1930.4 + 1950.2	41.3	47.51	56.36
661 + 760	1960.0 + 1979.8	41.3	47.33	54.08
710 + 809	1969.8 + 1989.6	41.3	47.30	53.70

AQPSK

ARFCN	Frequency (MHz)	Path Loss (dB)	Result (dBm) RMS	Result (W) RMS
513 + 612	1930.4 + 1950.2	41.3	47.42	55.21
661 + 760	1960.0 + 1979.8	41.3	47.42	55.21
710 + 809	1969.8 + 1989.6	41.3	47.40	54.95

**Multi Carrier (1x3)**Configuration 1 - Mode 7, 8 and 9GMSK

ARFCN	Frequency (MHz)	Path Loss (dB)	Result (dBm) RMS	Result (W) RMS
513 + 537 + 562	1930.4 + 1935.2 + 1940.2	41.3	48.47	70.31
637 + 661 + 686	1955.2 + 1960.0 + 1965	41.3	48.56	71.78
760 + 785 + 809	1979.8 + 1984.8 + 1989.6	41.3	48.48	70.47

8-PSK

ARFCN	Frequency (MHz)	Path Loss (dB)	Result (dBm) RMS	Result (W) RMS
513 + 537 + 562	1930.4 + 1935.2 + 1940.2	41.3	47.23	52.84
637 + 661 + 686	1955.2 + 1960.0 + 1965	41.3	47.27	53.33
760 + 785 + 809	1979.8 + 1984.8 + 1989.6	41.3	47.20	52.48

16QAM

ARFCN	Frequency (MHz)	Path Loss (dB)	Result (dBm) RMS	Result (W) RMS
513 + 537 + 562	1930.4 + 1935.2 + 1940.2	41.3	45.82	38.19
637 + 661 + 686	1955.2 + 1960.0 + 1965	41.3	45.85	38.46
760 + 785 + 809	1979.8 + 1984.8 + 1989.6	41.3	45.73	37.41

32QAM

ARFCN	Frequency (MHz)	Path Loss (dB)	Result (dBm) RMS	Result (W) RMS
513 + 537 + 562	1930.4 + 1935.2 + 1940.2	41.3	45.37	34.43
637 + 661 + 686	1955.2 + 1960.0 + 1965	41.3	45.38	34.51
760 + 785 + 809	1979.8 + 1984.8 + 1989.6	41.3	45.29	33.81

AQPSK

ARFCN	Frequency (MHz)	Path Loss (dB)	Result (dBm) RMS	Result (W) RMS
513 + 537 + 562	1930.4 + 1935.2 + 1940.2	41.3	47.09	51.17
637 + 661 + 686	1955.2 + 1960.0 + 1965	41.3	47.08	51.05
760 + 785 + 809	1979.8 + 1984.8 + 1989.6	41.3	46.98	49.89

**Multi Carrier (1x4)**

Configuration 1 - Mode 10, 11 and 12

GMSK

ARFCN	Frequency (MHz)	Path Loss (dB)	Result (dBm) RMS	Result (W) RMS
513 + 529 + 545 + 562	1930.4 + 1933.6 + 1936.8 + 1940.2	41.3	48.89	77.45
645 + 661 + 677 + 694	1956.8 + 1960.0 + 1963.2 + 1966.6	41.3	48.44	69.82
760 + 777 + 793 + 809	1979.8 + 1983.2 + 1986.4 + 1989.6	41.3	48.36	68.55

8-PSK

ARFCN	Frequency (MHz)	Path Loss (dB)	Result (dBm) RMS	Result (W) RMS
513 + 529 + 545 + 562	1930.4 + 1933.6 + 1936.8 + 1940.2	41.3	46.30	42.66
645 + 661 + 677 + 694	1956.8 + 1960.0 + 1963.2 + 1966.6	41.3	45.58	36.14
760 + 777 + 793 + 809	1979.8 + 1983.2 + 1986.4 + 1989.6	41.3	45.50	35.48

16QAM

ARFCN	Frequency (MHz)	Path Loss (dB)	Result (dBm) RMS	Result (W) RMS
513 + 529 + 545 + 562	1930.4 + 1933.6 + 1936.8 + 1940.2	41.3	44.24	26.55
645 + 661 + 677 + 694	1956.8 + 1960.0 + 1963.2 + 1966.6	41.3	44.12	25.82
760 + 777 + 793 + 809	1979.8 + 1983.2 + 1986.4 + 1989.6	41.3	44.04	25.35



32QAM

ARFCN	Frequency (MHz)	Path Loss (dB)	Result (dBm) RMS	Result (W) RMS
513 + 529 + 545 + 562	1930.4 + 1933.6 + 1936.8 + 1940.2	41.3	43.76	23.77
645 + 661 + 677 + 694	1956.8 + 1960.0 + 1963.2 + 1966.6	41.3	43.68	23.33
760 + 777 + 793 + 809	1979.8 + 1983.2 + 1986.4 + 1989.6	41.3	43.58	22.80

AQPSK

ARFCN	Frequency (MHz)	Path Loss (dB)	Result (dBm) RMS	Result (W) RMS
513 + 529 + 545 + 562	1930.4 + 1933.6 + 1936.8 + 1940.2	41.3	45.52	35.65
645 + 661 + 677 + 694	1956.8 + 1960.0 + 1963.2 + 1966.6	41.3	45.43	34.91
760 + 777 + 793 + 809	1979.8 + 1983.2 + 1986.4 + 1989.6	41.3	45.37	34.43

Limit	≤100W or ≤+50dBm
-------	------------------

Remarks

The EUT does not exceed 100W or 50dBm at the measured frequencies.



Product Service

2.2 PEAK – AVERAGE RATIO

2.2.1 Specification Reference

FCC CFR 47 Part 24, Clause 24.232 (d)
Industry Canada RSS-133, Clause 6.4

2.2.2 Equipment Under Test

RRUS 01 B2 / KRC 118 74/2, S/N: D162554351

2.2.3 Date of Test and Modification State

26, 27 February, 04 and 25 March 2013 – Modification State 0

2.2.4 Test Equipment Used

The major items of test equipment used for the above tests are identified in Section 3.1.

2.2.5 Test Method and Operating Modes

The test was applied in accordance with the test method requirements of FCC CFR 47 Part 24.

A peak to average ratio measurement is performed at the conducted port of the EUT. The spectrum analyzers Complementary Cumulative Distribution Function (CCDF) measurement profile is used to determine the largest deviation between the average and the peak power of the EUT in given bandwidth. The CCDF curve shows how much time the peak waveform spends at or above a given average power level. The percent of time the signal spends at or above the level defines the probability for that particular power level.

The path loss measured and entered as a reference level offset.

The test was performed with the EUT in the following configurations and modes of operation:

Configuration 1 - Mode 1
- Mode 2
- Mode 3
- Mode 4
- Mode 5
- Mode 6
- Mode 7
- Mode 8
- Mode 9
- Mode 10
- Mode 11
- Mode 12



Product Service

2.2.6 Environmental Conditions

	26 Feb. 2013	27 Feb. 2013	04 Mar. 2013	25 Mar. 2013
Ambient Temperature	20.7°C	21.0°C	23.0°C	20.8 °C
Relative Humidity	24.0%	20.2%	24.0%	23.5%

2.2.7 Test Results

For the period of test the EUT met the requirements of FCC CFR 47 Part 24 Peak – Average Ratio.

The test results are shown below.

Single Carrier

Configuration 1 - Mode 1

GMSK

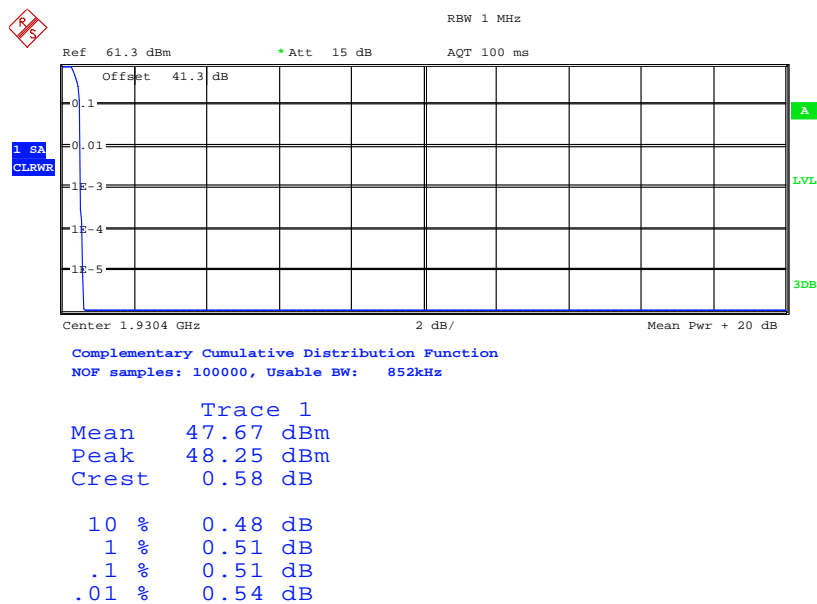

Date: 4.MAR.2013 04:02:06



Product Service

8-PSK

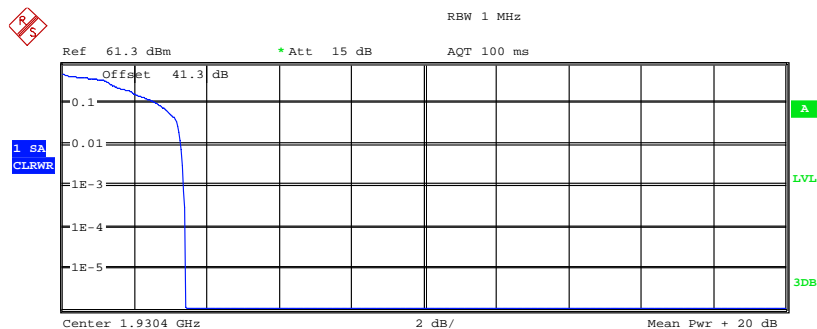

Complementary Cumulative Distribution Function
NOF samples: 100000, Usable BW: 852kHz

Trace 1	
Mean	47.87 dBm
Peak	51.28 dBm
Crest	3.41 dB
10 %	2.63 dB
1 %	3.30 dB
.1 %	3.37 dB
.01 %	3.43 dB

Date: 4.MAR.2013 04:00:19

16QAM

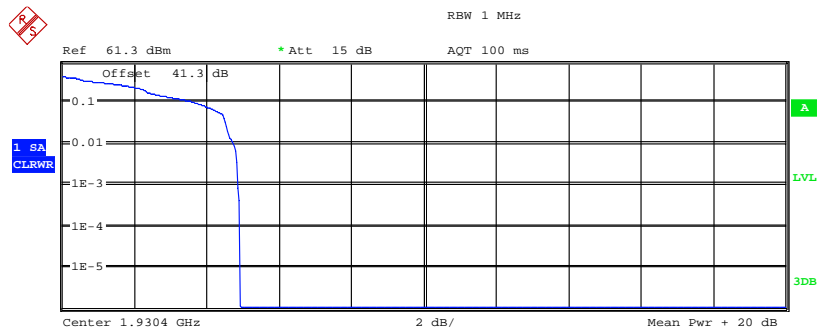

Complementary Cumulative Distribution Function
NOF samples: 100000, Usable BW: 852kHz

Trace 1	
Mean	47.55 dBm
Peak	52.48 dBm
Crest	4.93 dB
10 %	3.69 dB
1 %	4.74 dB
.1 %	4.87 dB
.01 %	4.94 dB

Date: 4.MAR.2013 03:56:36



Product Service

32QAM

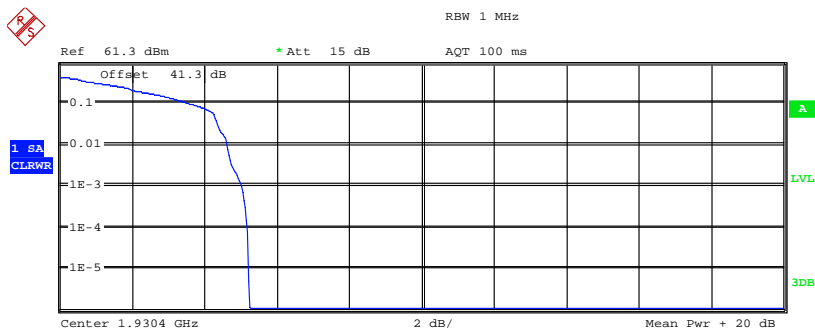

Complementary Cumulative Distribution Function
NOF samples: 100000, Usable BW: 852kHz

Trace 1	
Mean	47.47 dBm
Peak	52.69 dBm
Crest	5.22 dB
10 %	3.62 dB
1 %	4.62 dB
.1 %	5.03 dB
.01 %	5.19 dB

Date: 4.MAR.2013 03:53:35

AQPSK

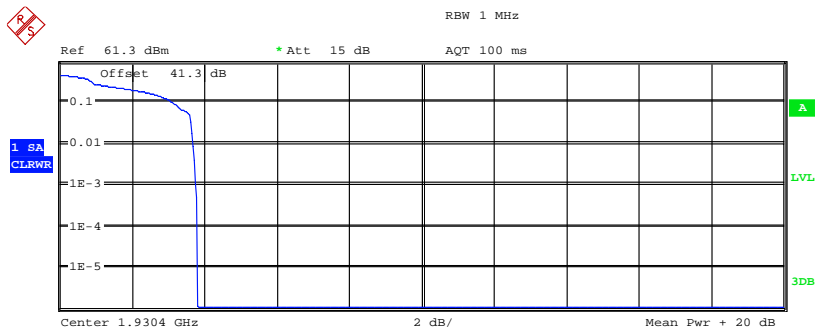

Complementary Cumulative Distribution Function
NOF samples: 100000, Usable BW: 852kHz

Trace 1	
Mean	47.62 dBm
Peak	51.42 dBm
Crest	3.80 dB
10 %	3.11 dB
1 %	3.69 dB
.1 %	3.75 dB
.01 %	3.81 dB

Date: 4.MAR.2013 04:20:08



Configuration 1 – Mode 2

GMSK

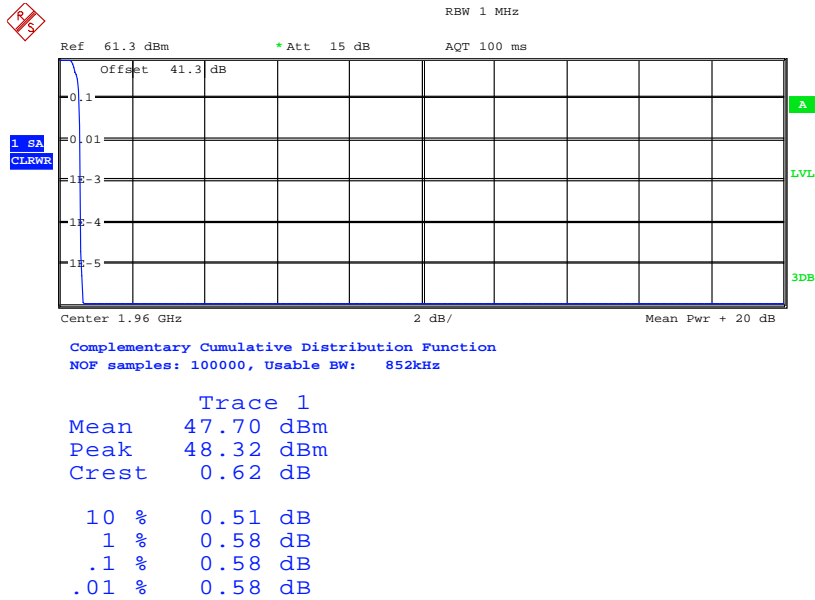

Date: 4.MAR.2013 04:03:19

8-PSK

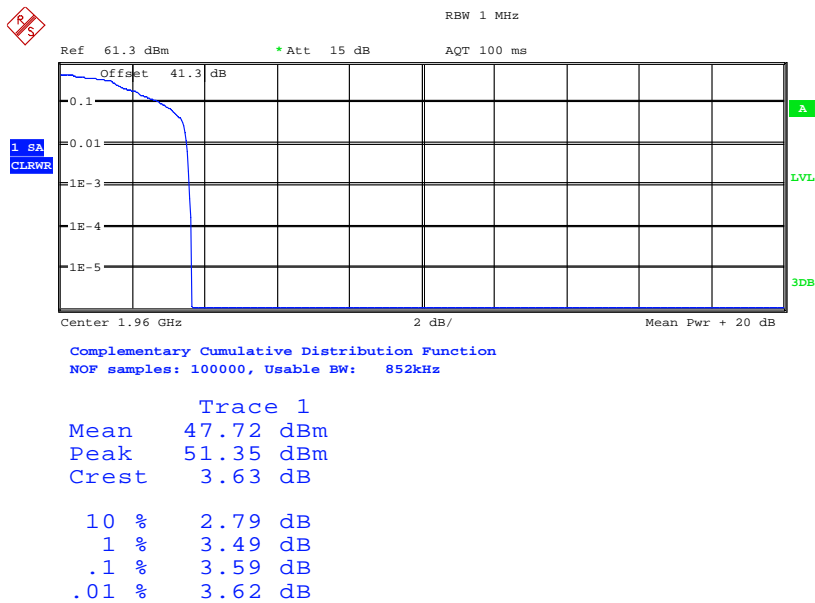

Date: 4.MAR.2013 04:04:40



16QAM

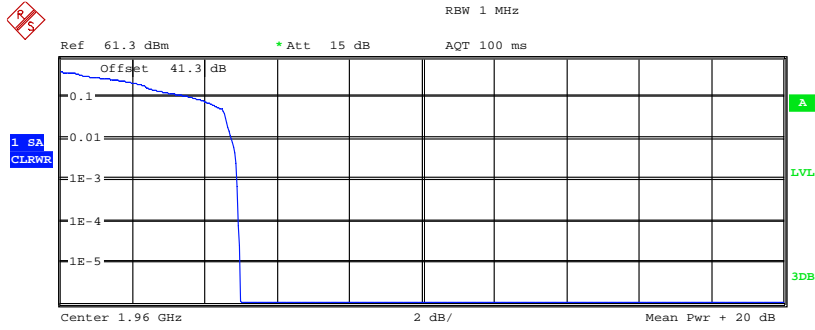

Complementary Cumulative Distribution Function
 NOF samples: 100000, Usable BW: 852kHz

Trace 1	
Mean	47.57 dBm
Peak	52.55 dBm
Crest	4.98 dB
10 %	3.69 dB
1 %	4.74 dB
.1 %	4.90 dB
.01 %	4.94 dB

Date: 4.MAR.2013 04:06:21

32QAM

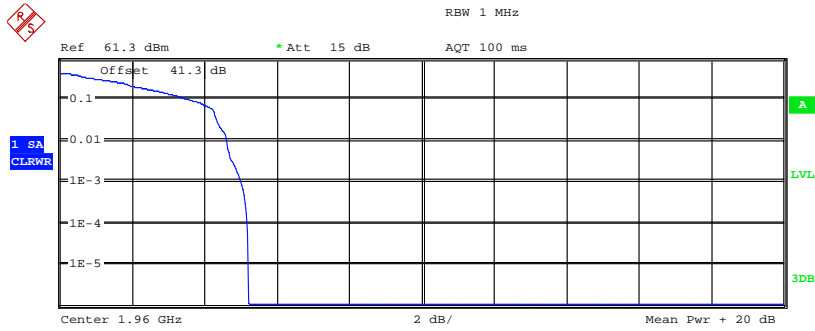

Complementary Cumulative Distribution Function
 NOF samples: 100000, Usable BW: 852kHz

Trace 1	
Mean	47.56 dBm
Peak	52.76 dBm
Crest	5.20 dB
10 %	3.59 dB
1 %	4.62 dB
.1 %	5.00 dB
.01 %	5.19 dB

Date: 4.MAR.2013 04:08:48



AQPSK

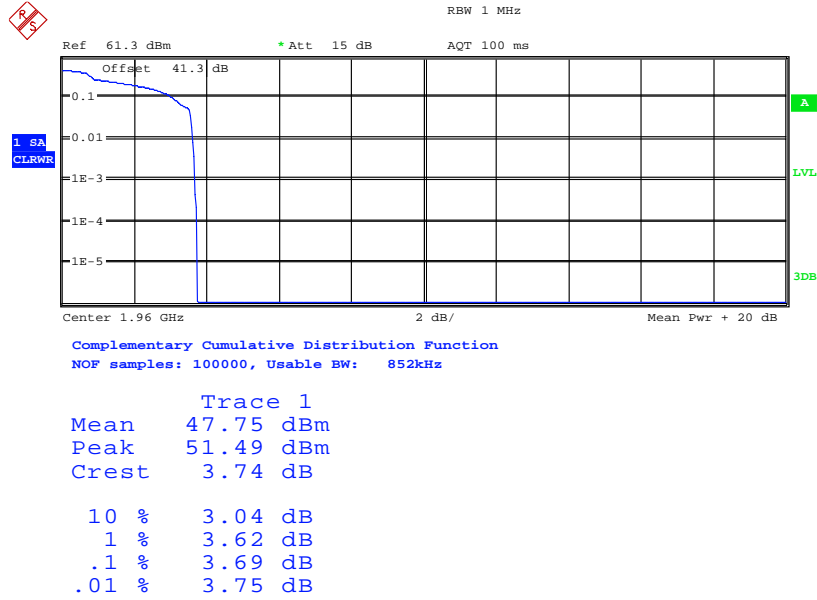

Date: 4.MAR.2013 04:18:52

Configuration 1 – Mode 3

GMSK

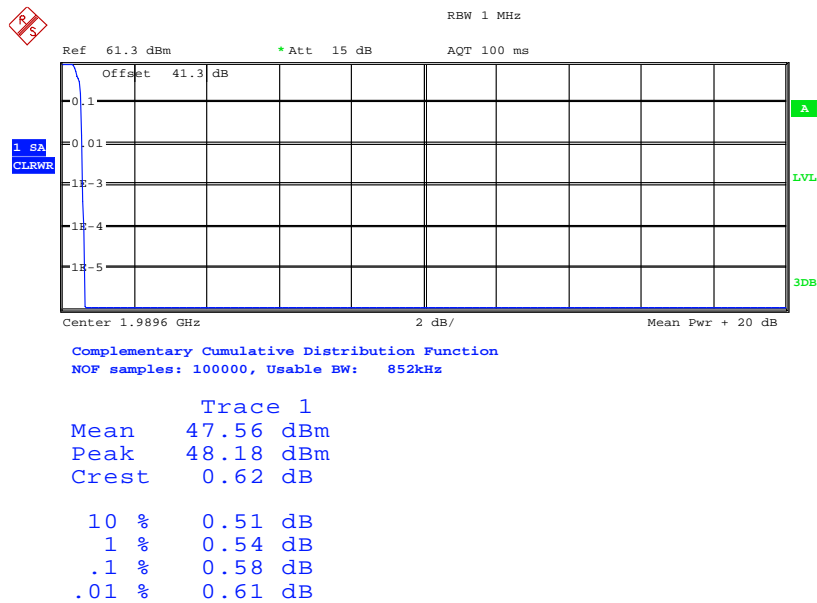

Date: 4.MAR.2013 04:14:21



Product Service

8-PSK

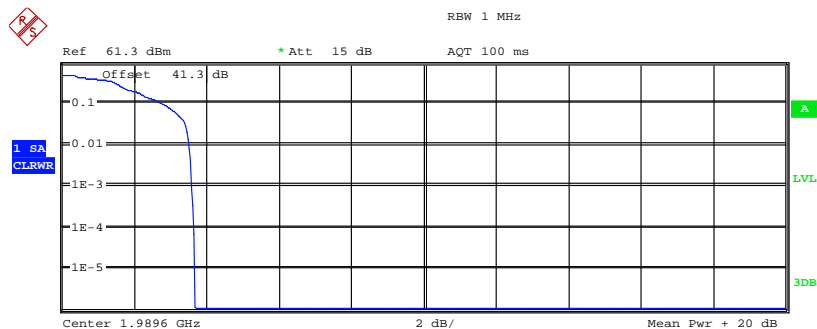

Complementary Cumulative Distribution Function
NOF samples: 100000, Usable BW: 852kHz

Trace 1	
Mean	47.55 dBm
Peak	51.21 dBm
Crest	3.66 dB
10 %	2.76 dB
1 %	3.53 dB
.1 %	3.59 dB
.01 %	3.65 dB

Date: 4.MAR.2013 04:12:38

16QAM

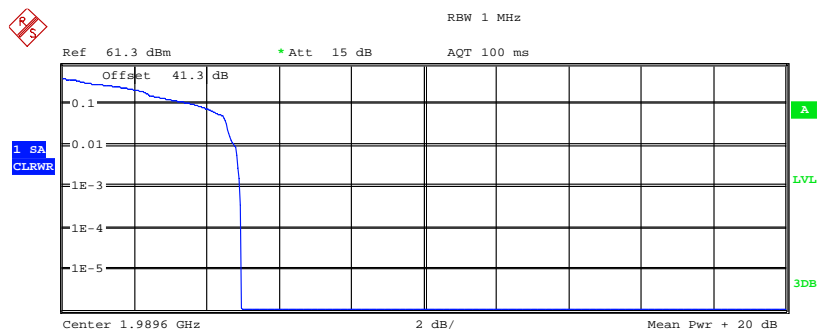

Complementary Cumulative Distribution Function
NOF samples: 100000, Usable BW: 852kHz

Trace 1	
Mean	47.47 dBm
Peak	52.41 dBm
Crest	4.94 dB
10 %	3.69 dB
1 %	4.78 dB
.1 %	4.90 dB
.01 %	4.97 dB

Date: 4.MAR.2013 04:10:47



Product Service

32QAM

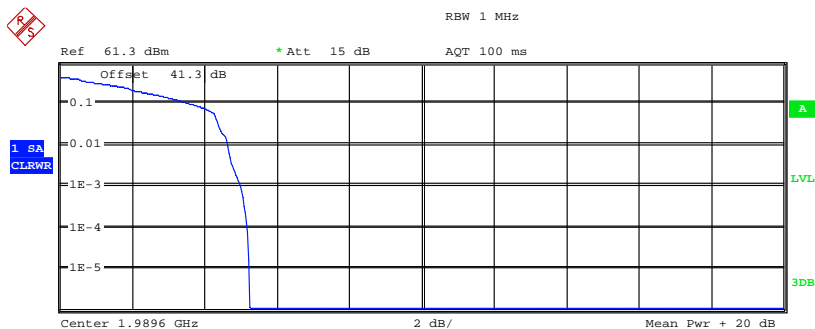

Complementary Cumulative Distribution Function
 NOF samples: 100000, Usable BW: 852kHz

Trace 1	
Mean	47.40 dBm
Peak	52.62 dBm
Crest	5.22 dB
10 %	3.62 dB
1 %	4.65 dB
.1 %	5.00 dB
.01 %	5.19 dB

Date: 4.MAR.2013 04:10:05

AQPSK

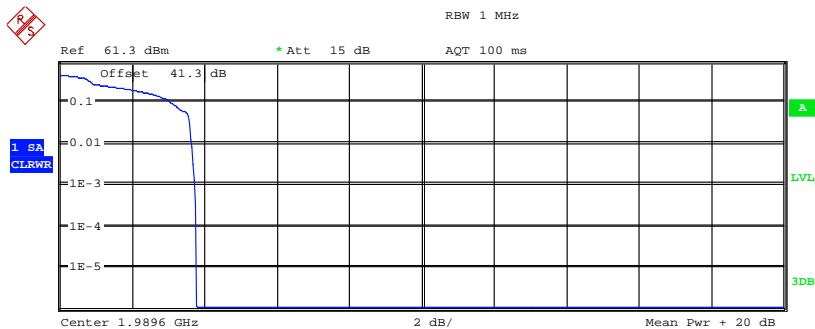

Complementary Cumulative Distribution Function
 NOF samples: 100000, Usable BW: 852kHz

Trace 1	
Mean	47.59 dBm
Peak	51.35 dBm
Crest	3.76 dB
10 %	3.08 dB
1 %	3.65 dB
.1 %	3.72 dB
.01 %	3.78 dB

Date: 4.MAR.2013 04:16:57



Multi Carrier (1x2)

Configuration 1 - Mode 4

GMSK

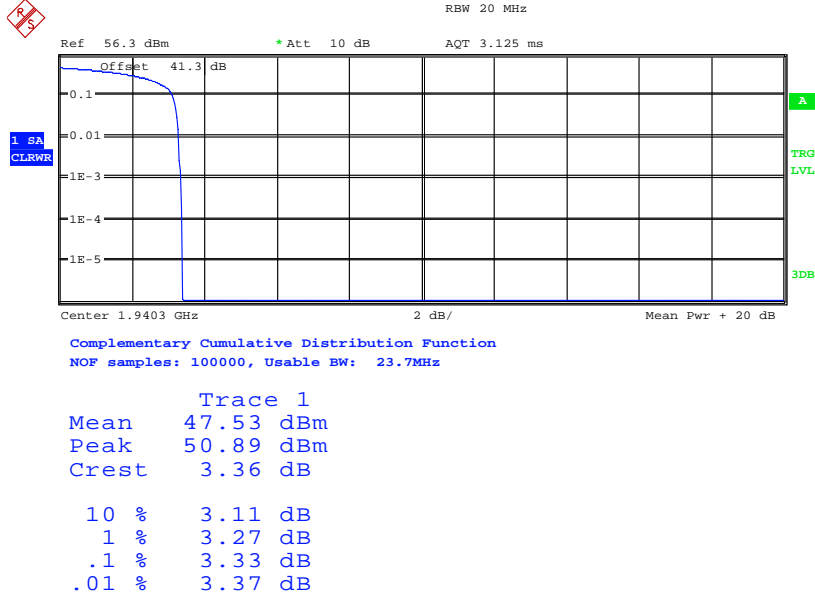

Date: 27.FEB.2013 04:21:44

8-PSK

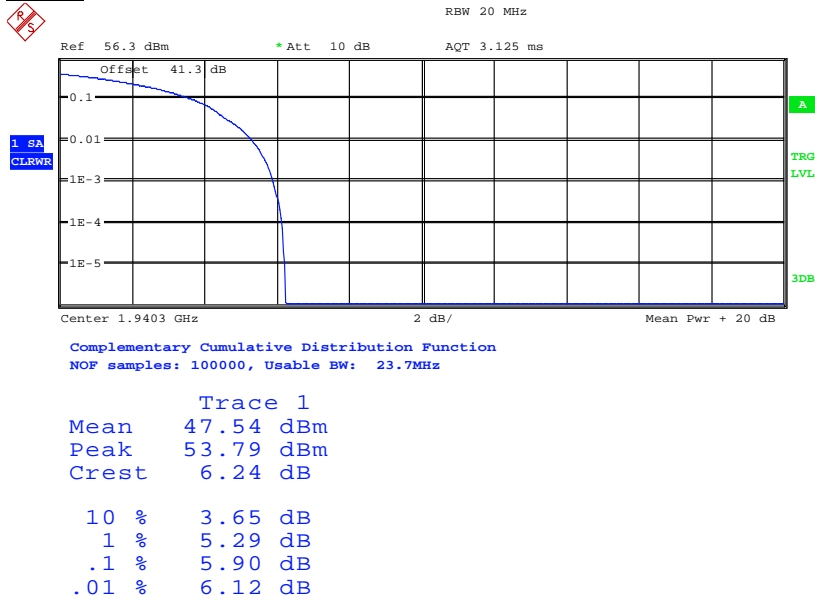

Date: 27.FEB.2013 04:23:48



16QAM

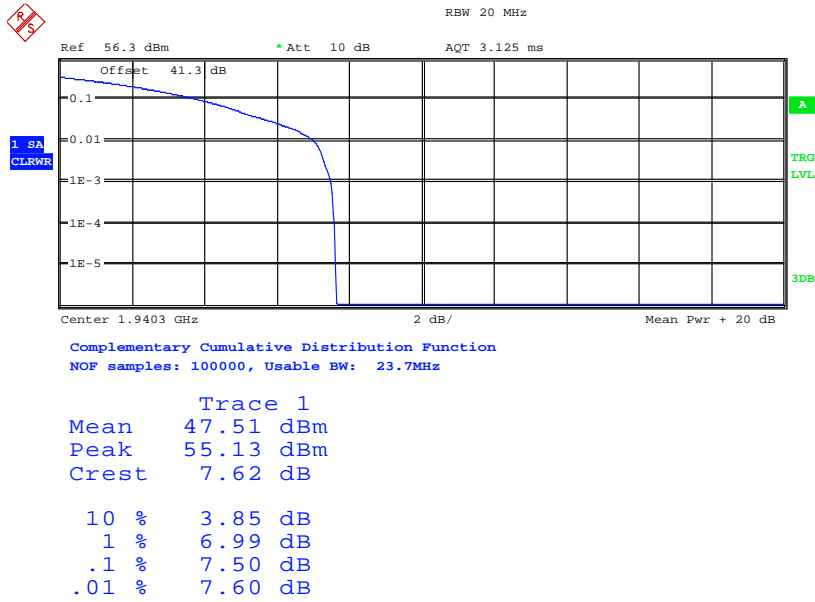

Date: 27.FEB.2013 04:25:08

32QAM

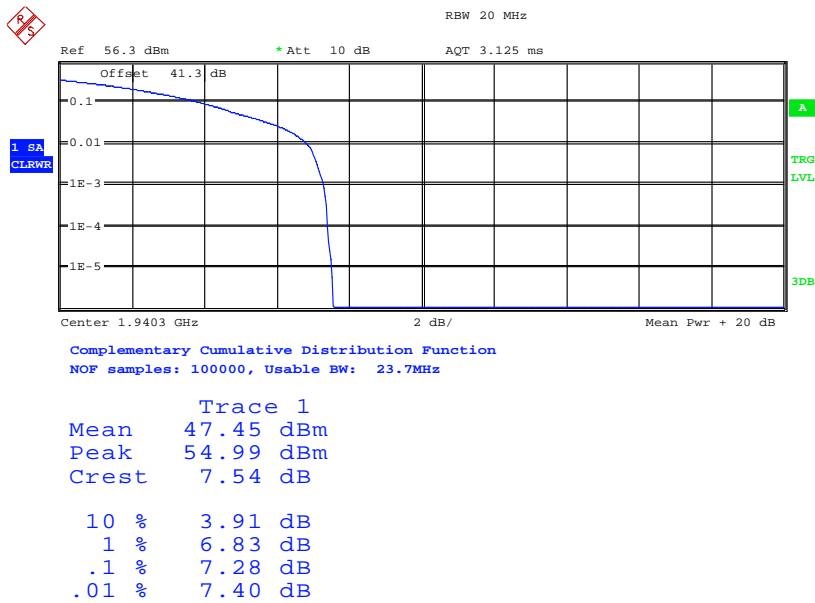

Date: 27.FEB.2013 04:26:49



Product Service

AQPSK

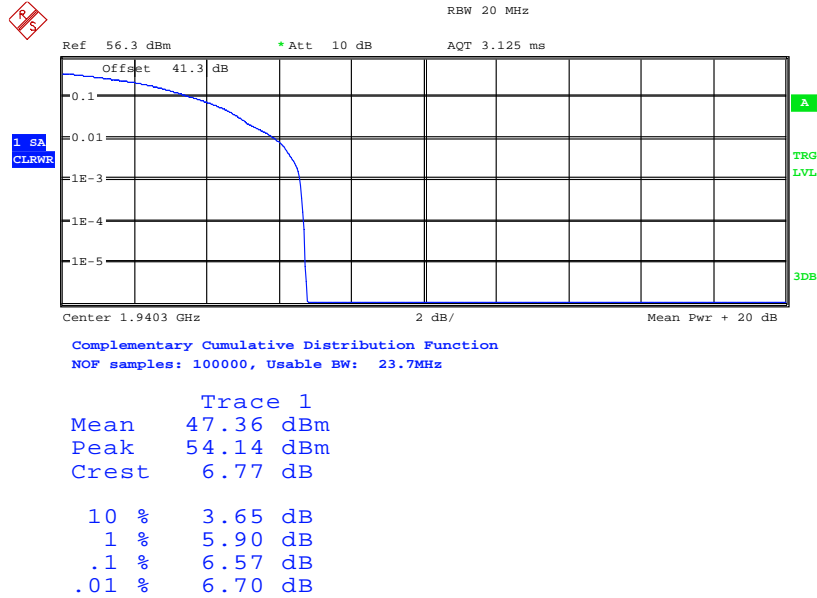

Date: 27.FEB.2013 04:46:28

Configuration 1 – Mode 5

GMSK

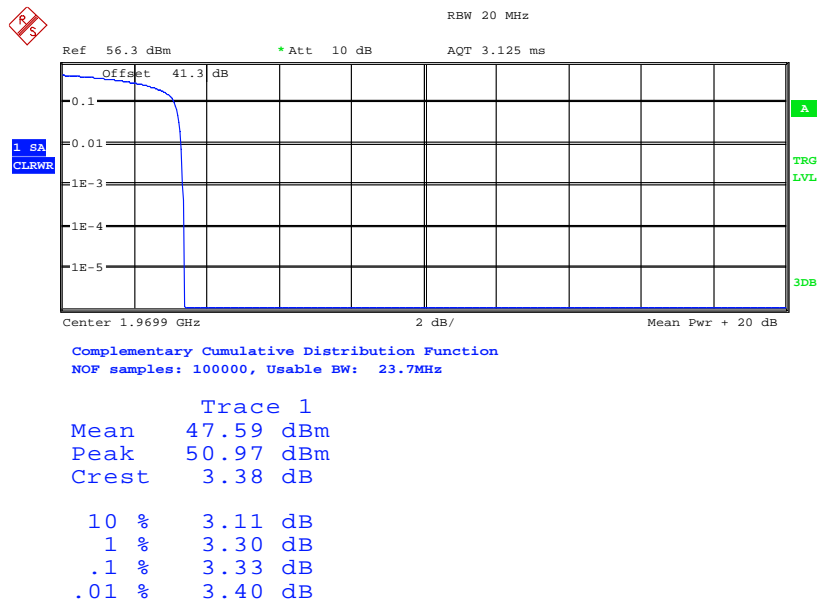

Date: 27.FEB.2013 04:33:18



8-PSK

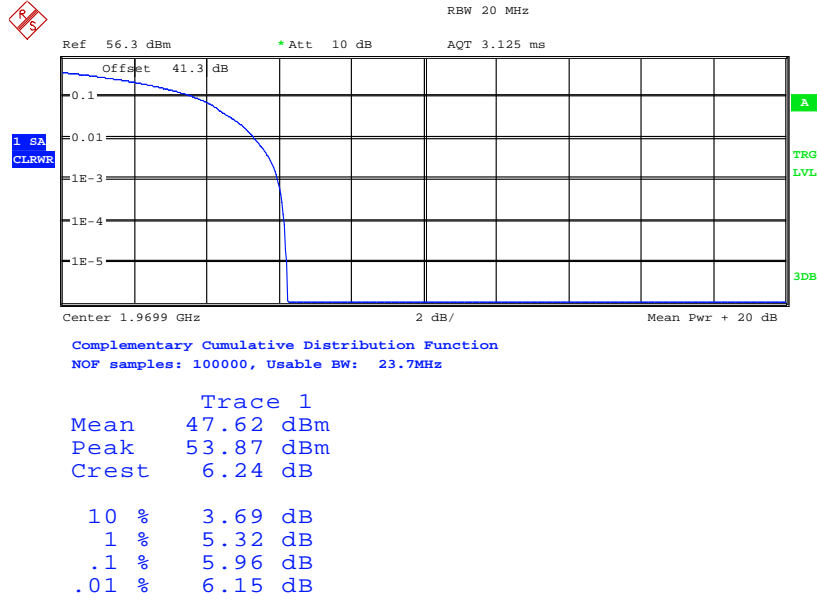

Date: 27.FEB.2013 04:31:32

16QAM

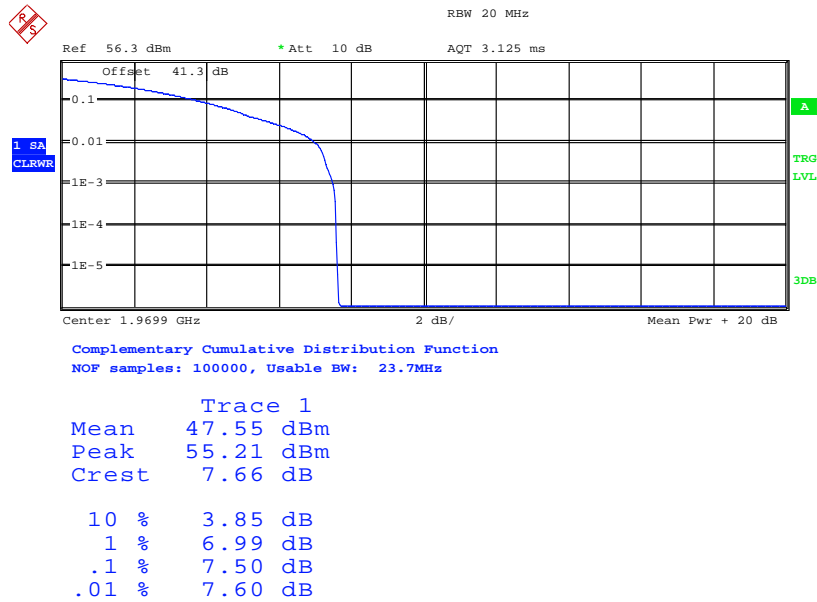

Date: 27.FEB.2013 04:30:03



32QAM

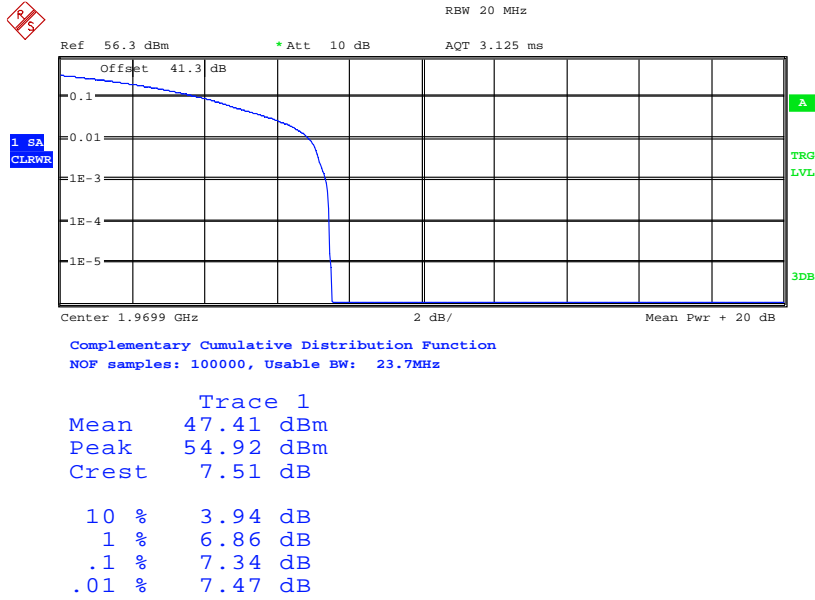

Date: 27.FEB.2013 04:28:33

AQPSK

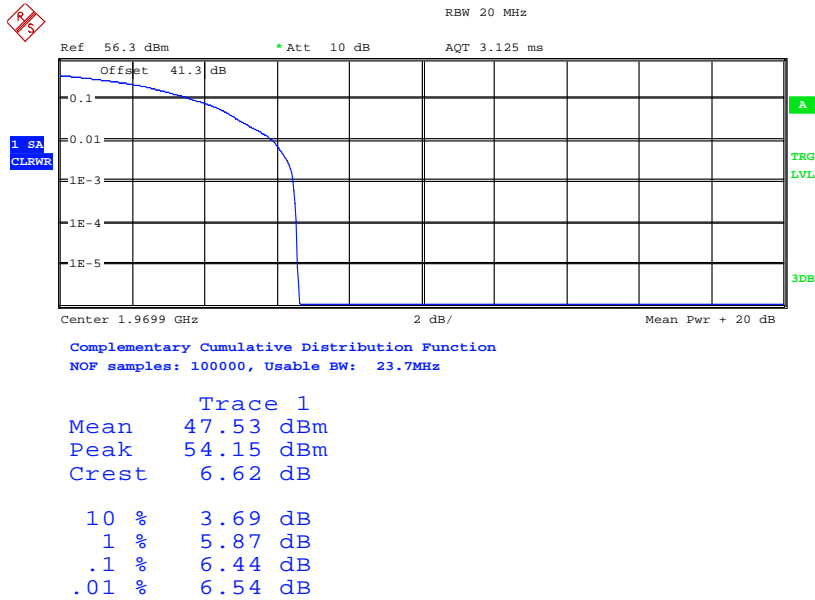

Date: 27.FEB.2013 04:42:54



Configuration 1 – Mode 6

GMSK

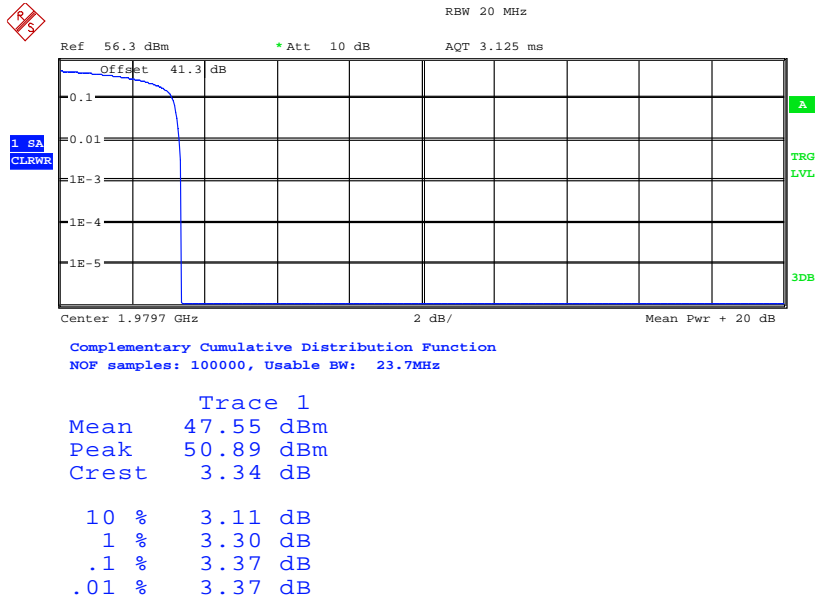

Date: 27.FEB.2013 04:35:01

8-PSK

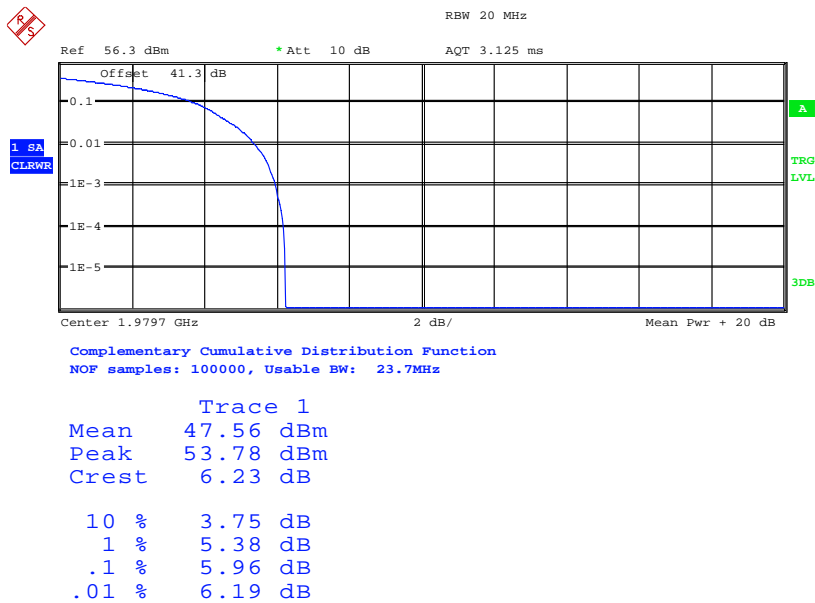

Date: 27.FEB.2013 04:36:27



16QAM

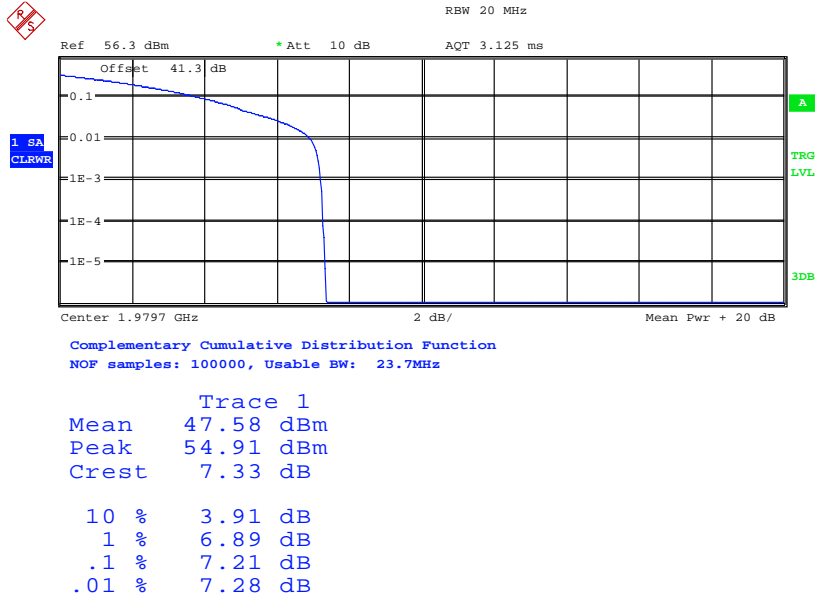

Date: 27.FEB.2013 04:37:40

32QAM

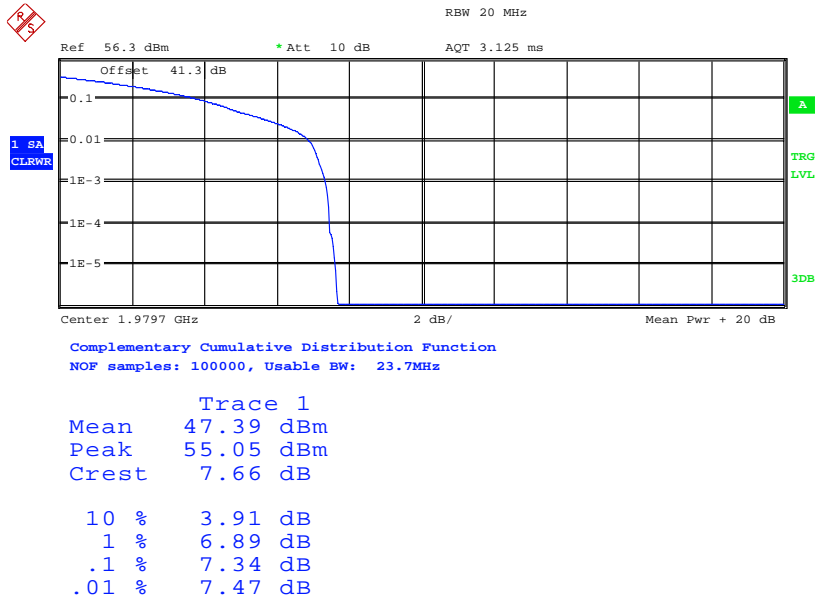

Date: 27.FEB.2013 04:38:40



Product Service

AQPSK

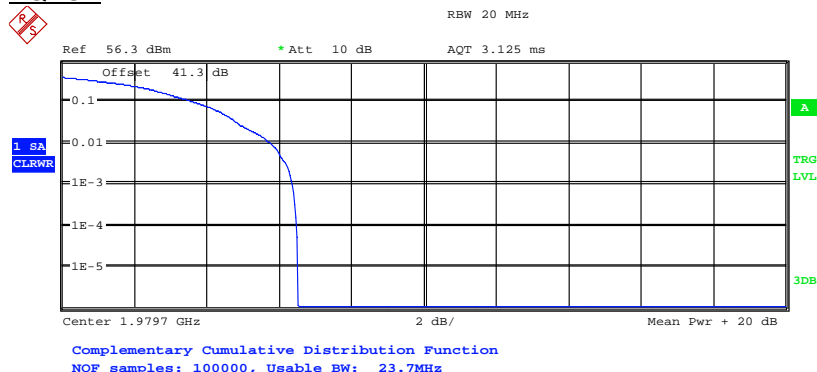

Trace 1	
Mean	47.55 dBm
Peak	54.07 dBm
Crest	6.51 dB
10 %	3.65 dB
1 %	5.77 dB
.1 %	6.38 dB
.01 %	6.51 dB

Date: 27.FEB.2013 04:41:01

Multi Carrier (1x3)

Configuration 1 - Mode 7

GMSK

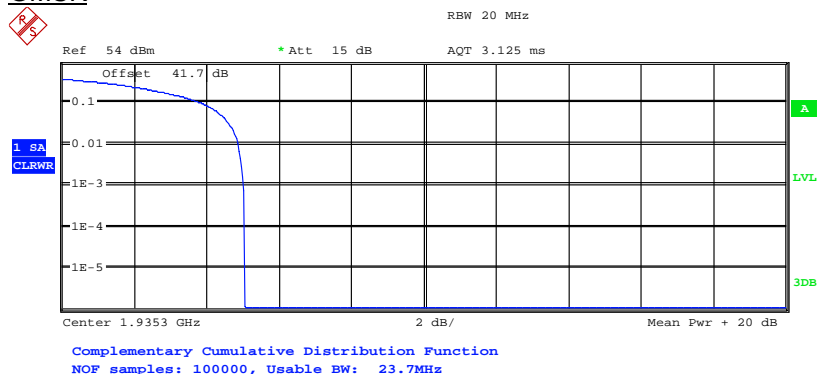

Trace 1	
Mean	48.90 dBm
Peak	53.95 dBm
Crest	5.05 dB
10 %	3.85 dB
1 %	4.87 dB
.1 %	5.03 dB
.01 %	5.06 dB

Date: 25.MAR.2013 04:58:16



8-PSK

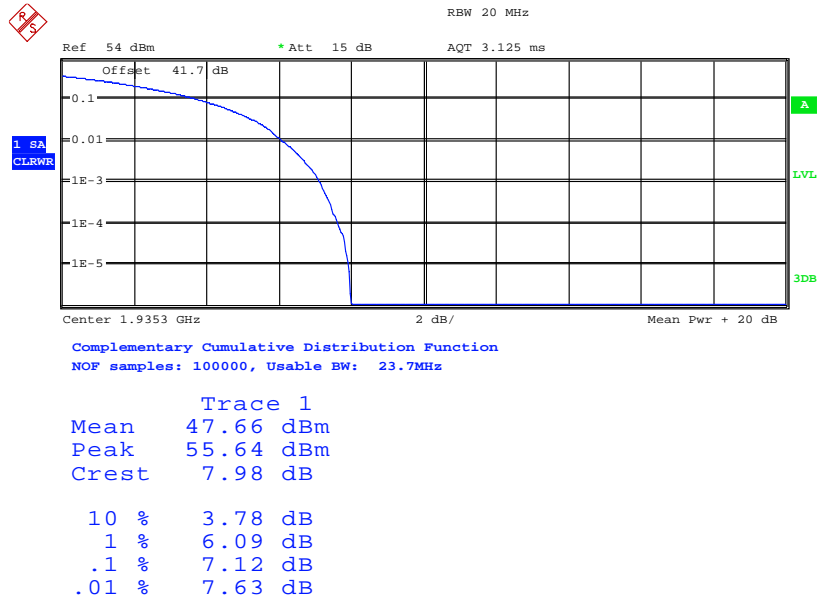

Date: 25.MAR.2013 04:56:45

16QAM

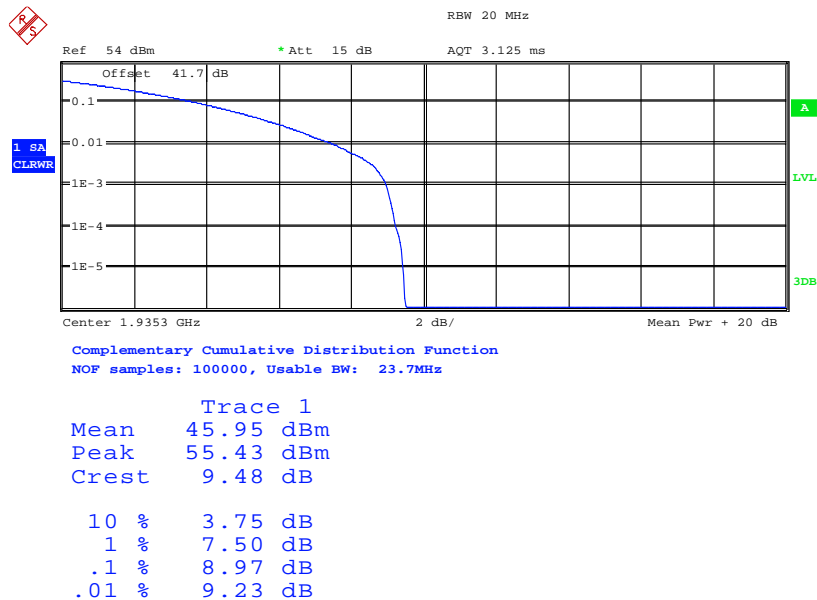

Date: 25.MAR.2013 07:33:23



32QAM

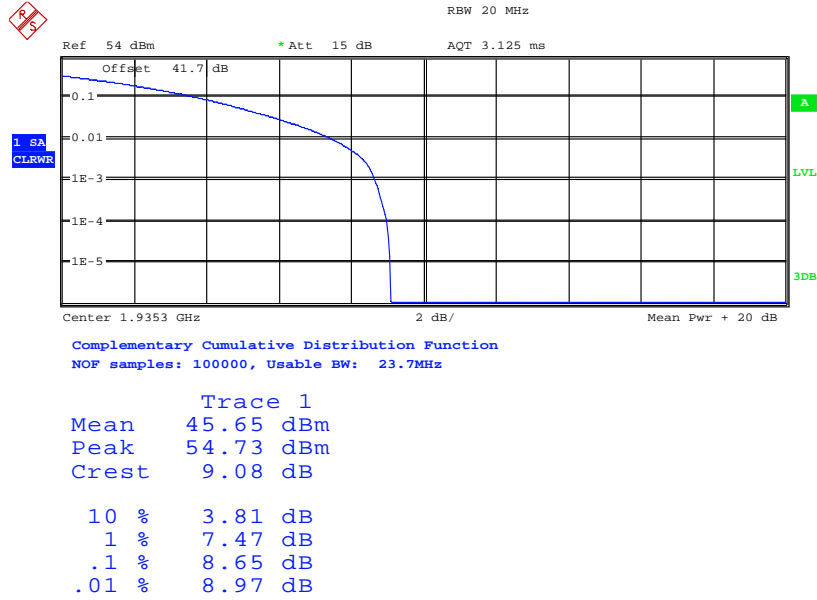

Date: 25.MAR.2013 07:31:58

AQPSK

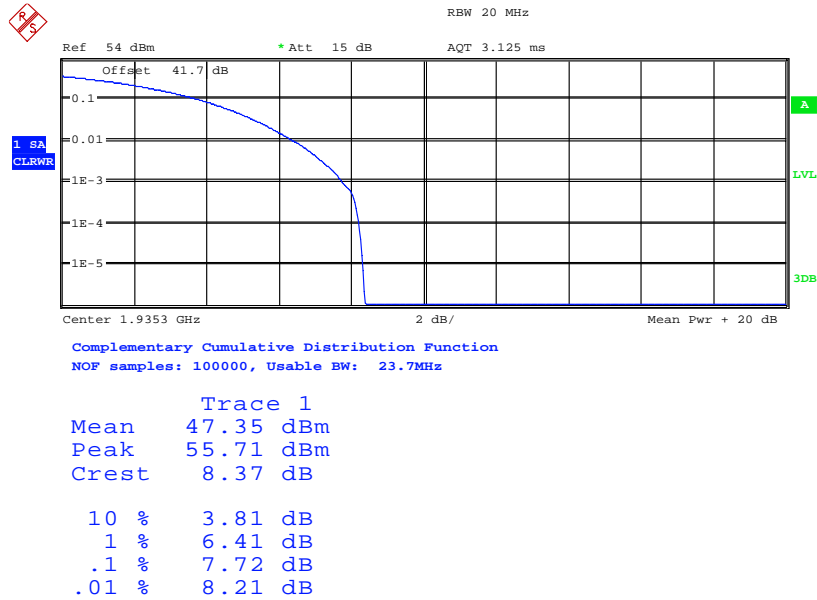

Date: 25.MAR.2013 07:50:33



Product Service

Configuration 1 – Mode 8

GMSK

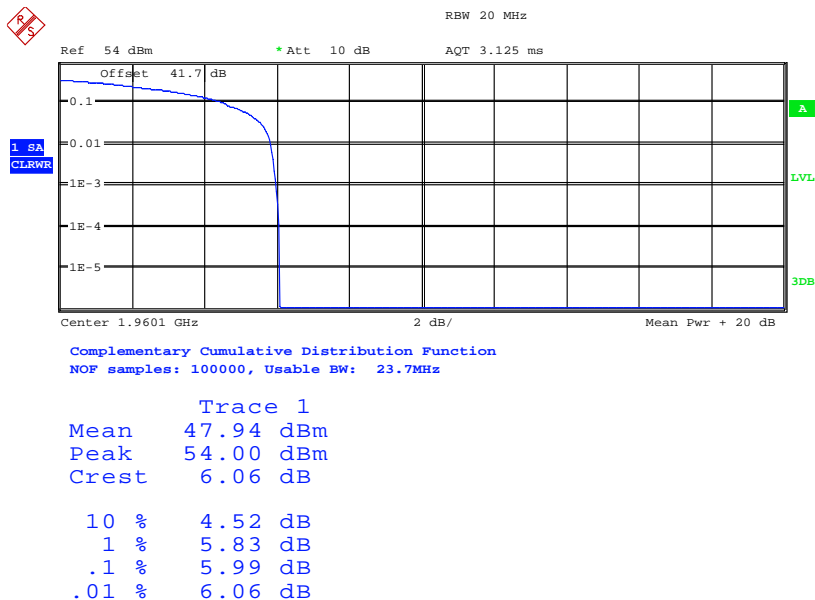

Date: 25.MAR.2013 05:02:25

8-PSK

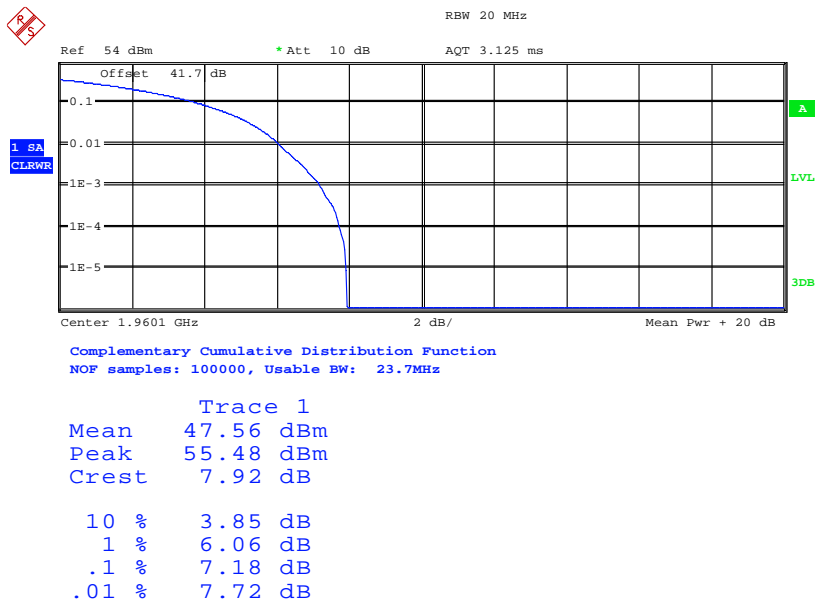

Date: 25.MAR.2013 05:03:55



16QAM

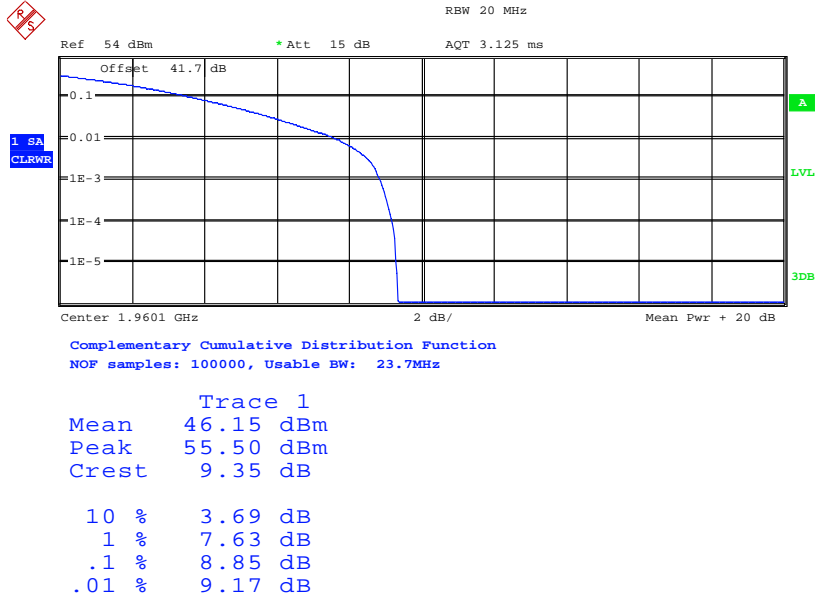

Date: 25.MAR.2013 07:35:35

32QAM

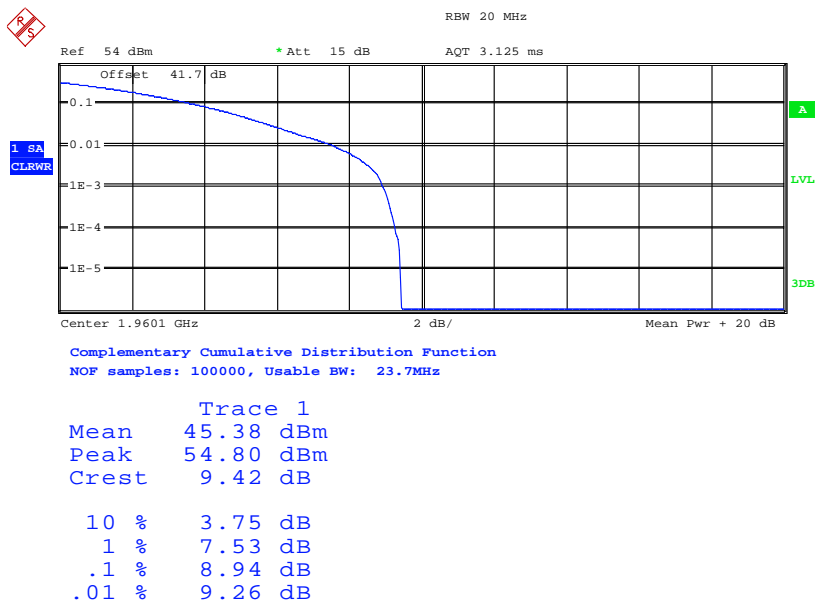

Date: 25.MAR.2013 07:36:49



AQPSK

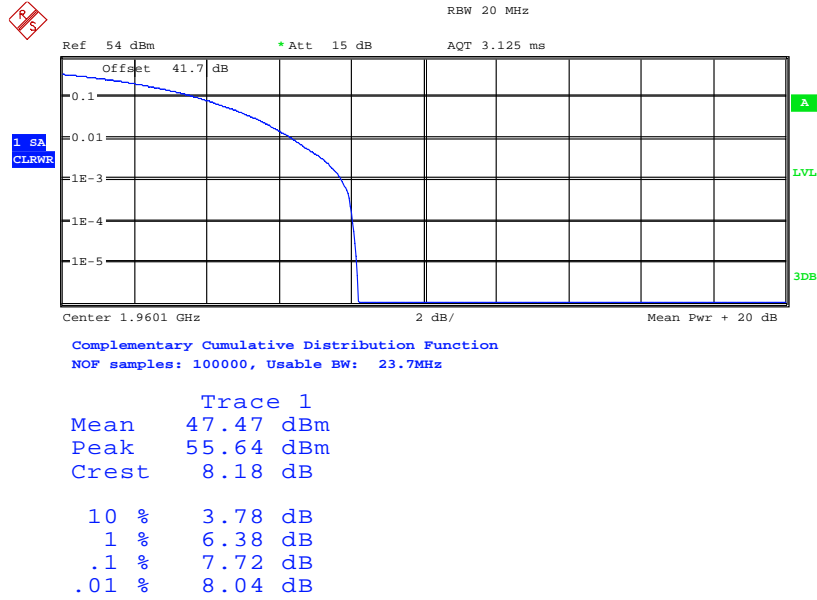

Date: 25.MAR.2013 07:47:34

Configuration 1 – Mode 9

GMSK

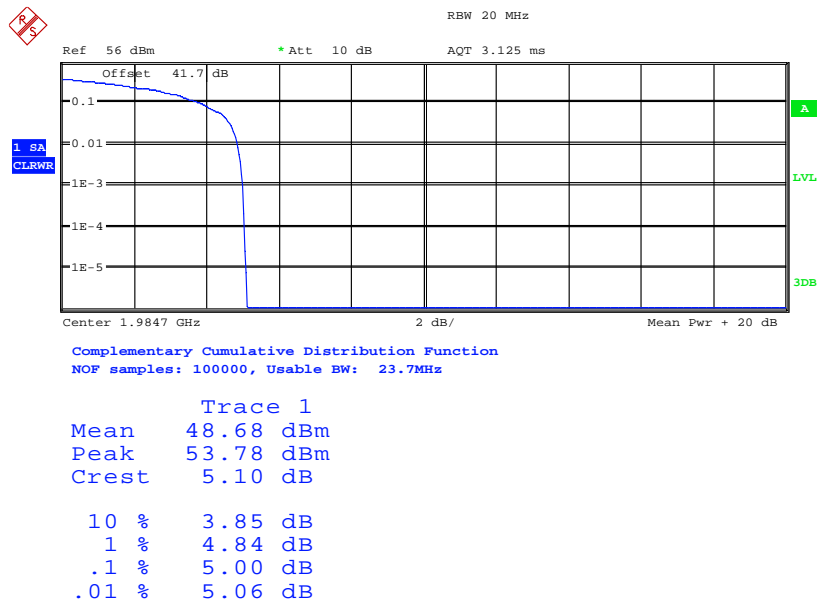

Date: 25.MAR.2013 03:10:21



Product Service

8-PSK

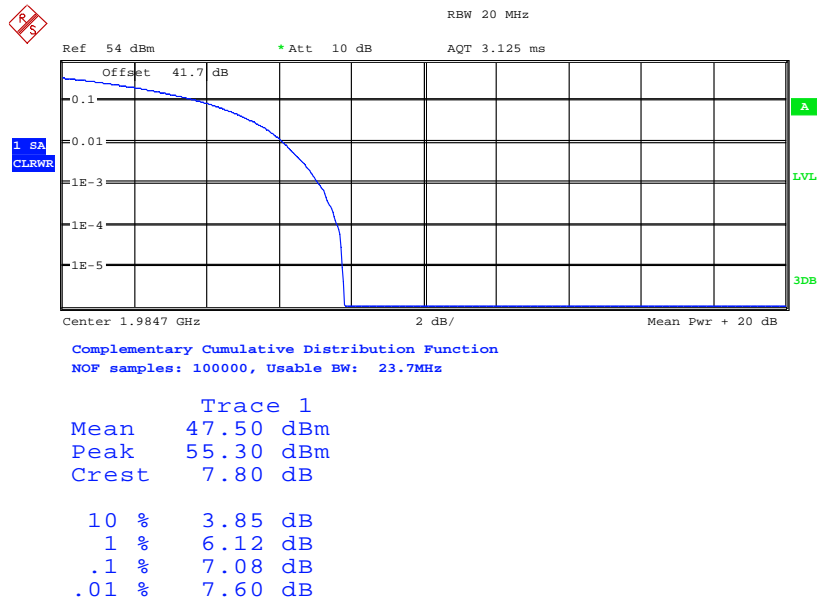

Date: 25.MAR.2013 03:55:11

16QAM

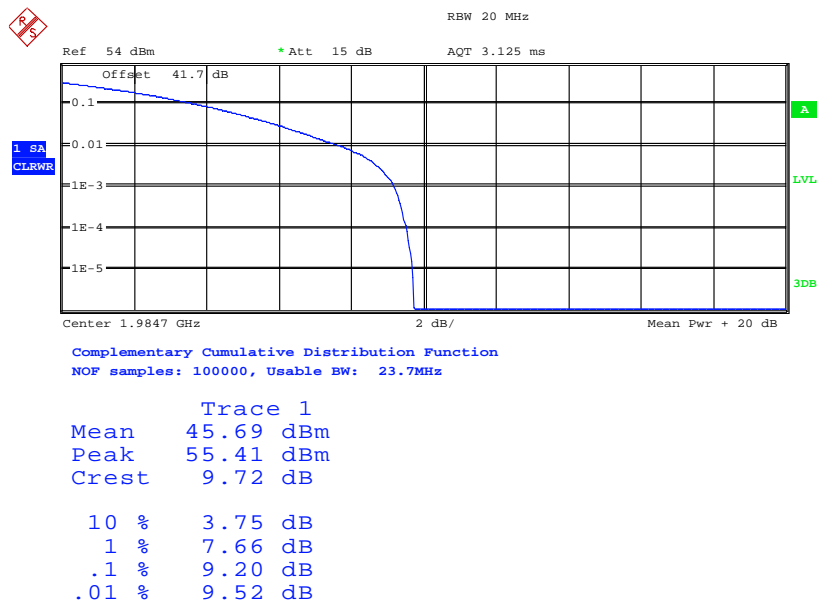

Date: 25.MAR.2013 07:40:57



32QAM

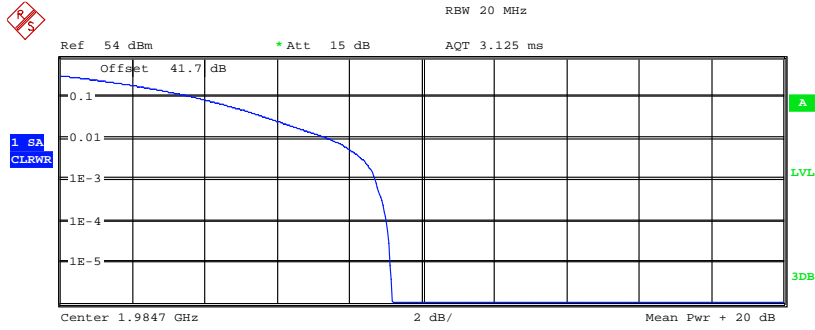

Complementary Cumulative Distribution Function
NOF samples: 100000, Usable BW: 23.7MHz

Trace 1

Mean	45.60 dBm
Peak	54.78 dBm
Crest	9.18 dB
10 %	3.81 dB
1 %	7.44 dB
.1 %	8.72 dB
.01 %	9.04 dB

Date: 25.MAR.2013 07:39:07

AQPSK

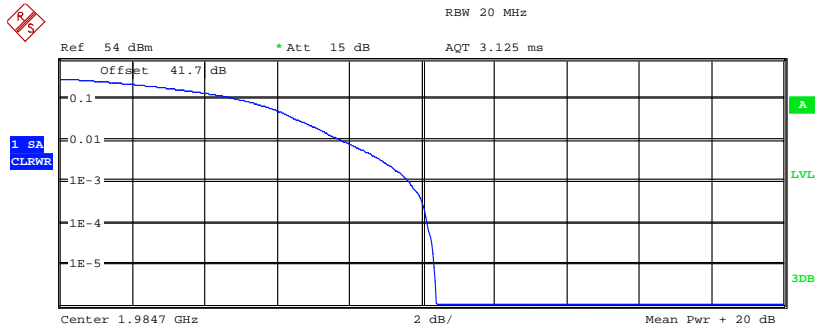

Complementary Cumulative Distribution Function
NOF samples: 100000, Usable BW: 23.7MHz

Trace 1

Mean	45.23 dBm
Peak	55.62 dBm
Crest	10.39 dB
10 %	5.00 dB
1 %	7.82 dB
.1 %	9.65 dB
.01 %	10.16 dB

Date: 25.MAR.2013 07:44:21



Multi Carrier (1x4)

Configuration 1 – Mode 10

GMSK

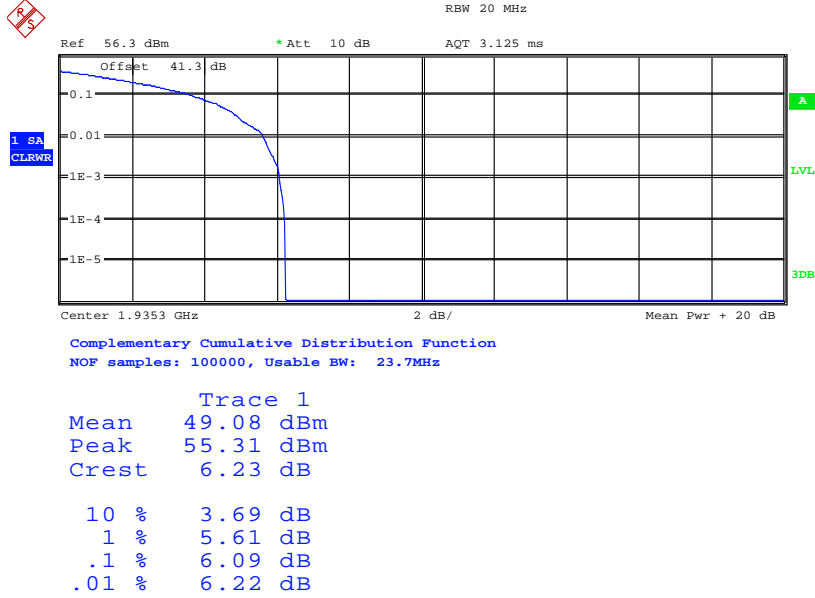

Date: 26.FEB.2013 07:16:36

8-PSK

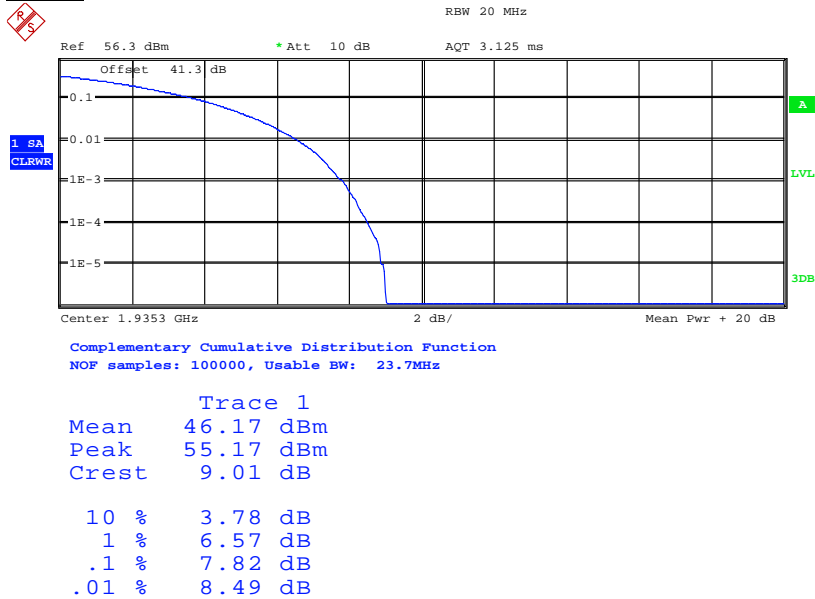

Date: 26.FEB.2013 07:19:36



16QAM

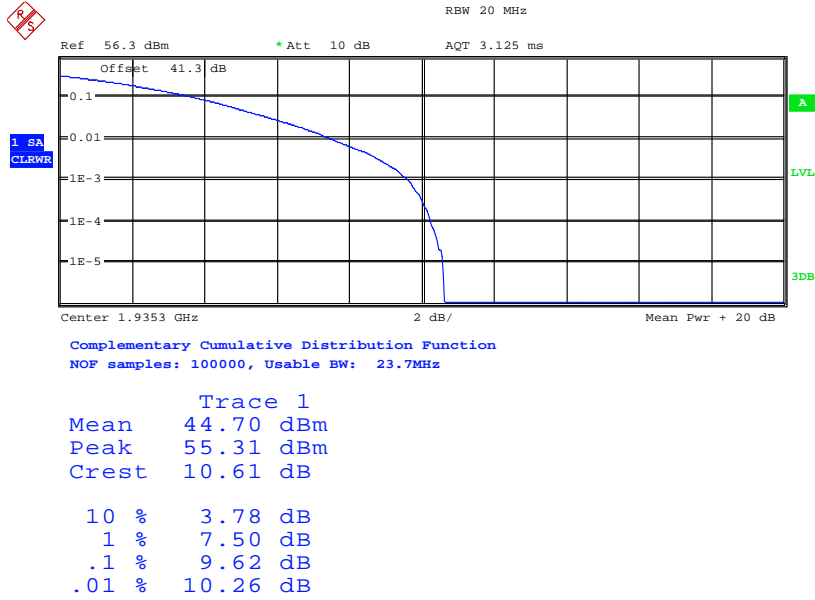

Date: 26.FEB.2013 07:22:11

32QAM

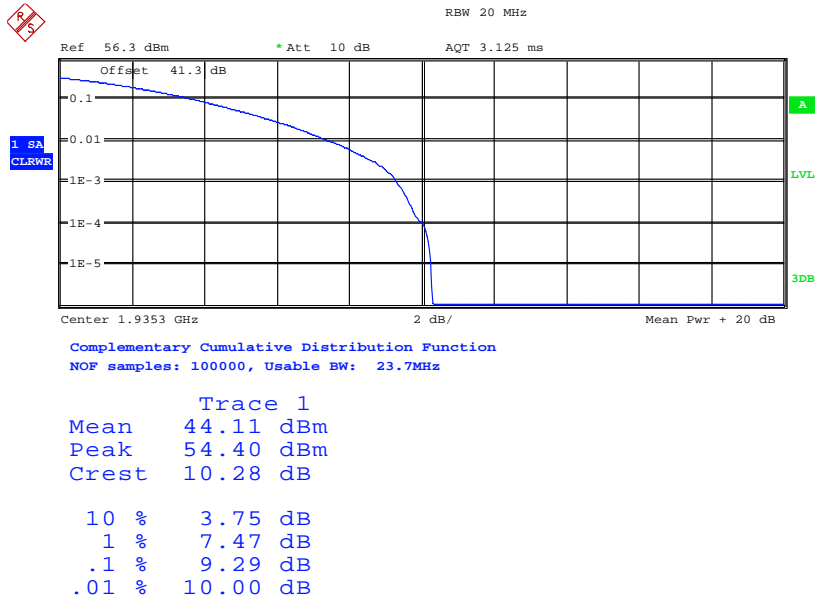

Date: 26.FEB.2013 07:24:50



AQPSK

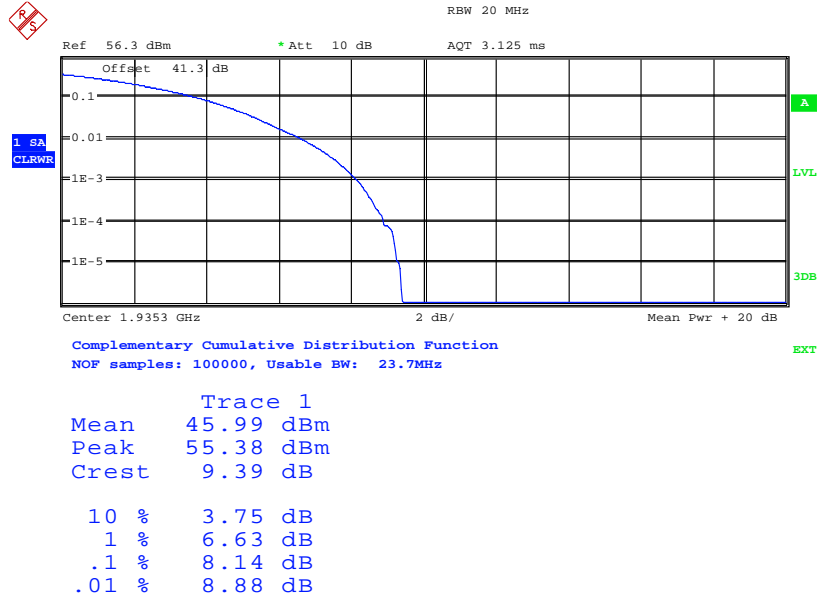

Date: 26.FEB.2013 06:04:06

Configuration 1 – Mode 11

GMSK

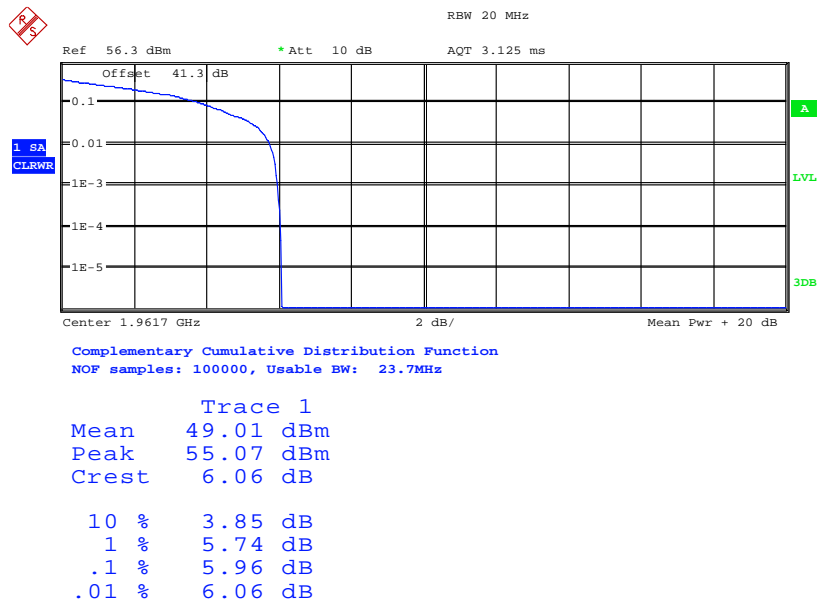

Date: 26.FEB.2013 07:12:52



Product Service

8-PSK

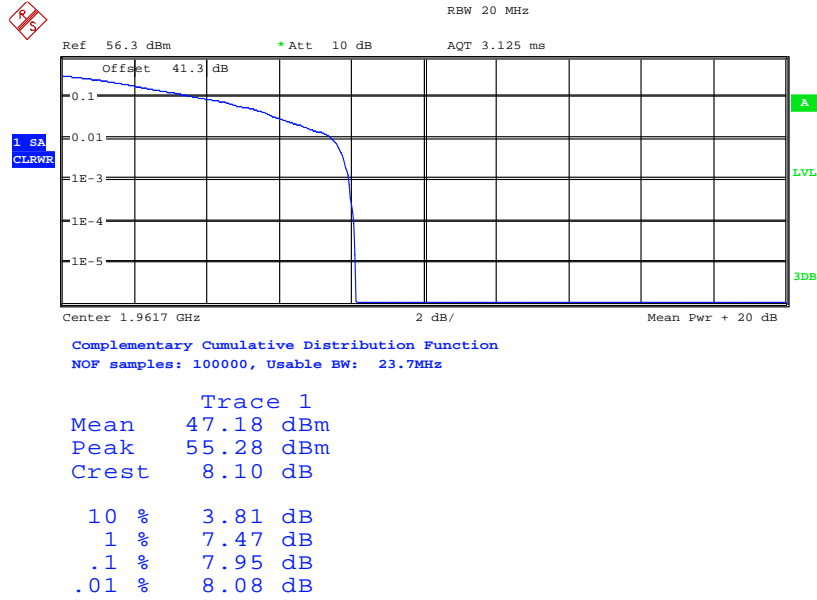

Date: 26.FEB.2013 07:09:36

16QAM

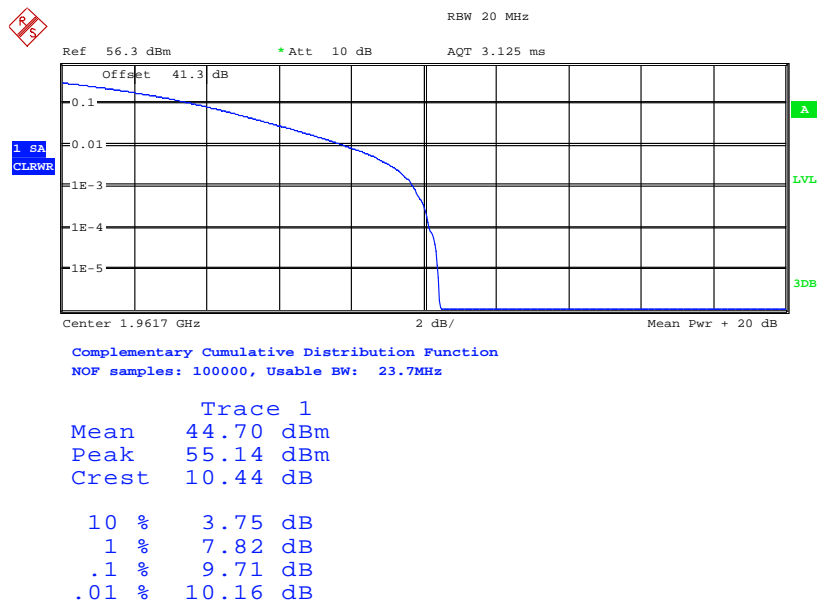

Date: 26.FEB.2013 07:06:34



Product Service

32QAM

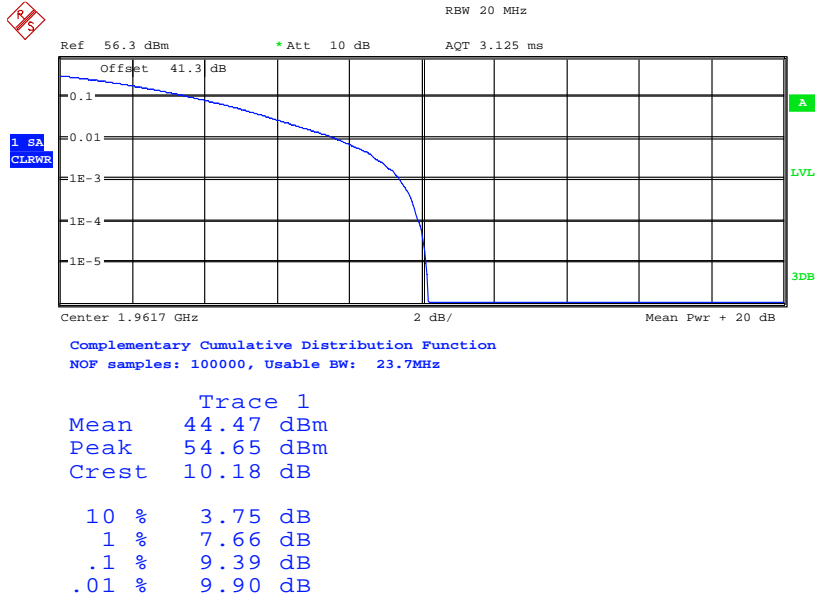

Date: 26.FEB.2013 07:03:58

AQPSK

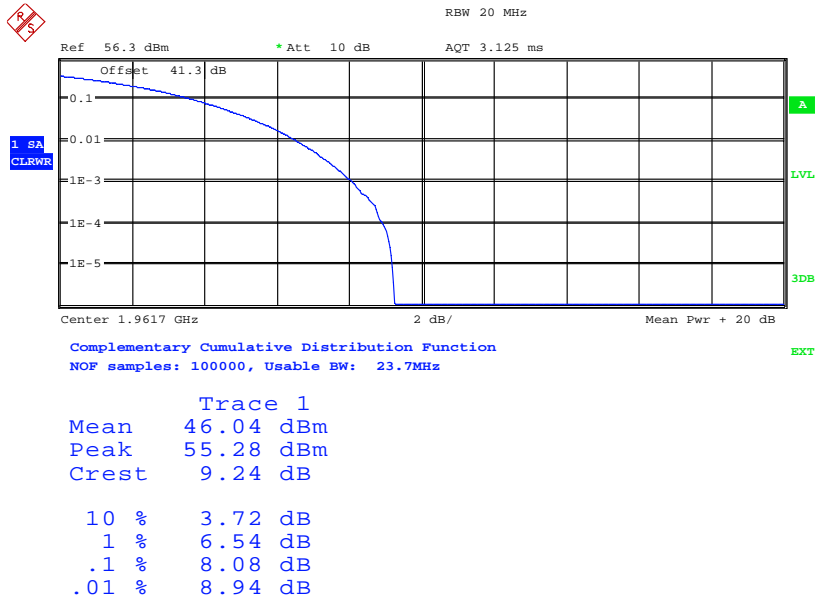

Date: 26.FEB.2013 06:09:53



Product Service

Configuration 1 – Mode 12

GMSK

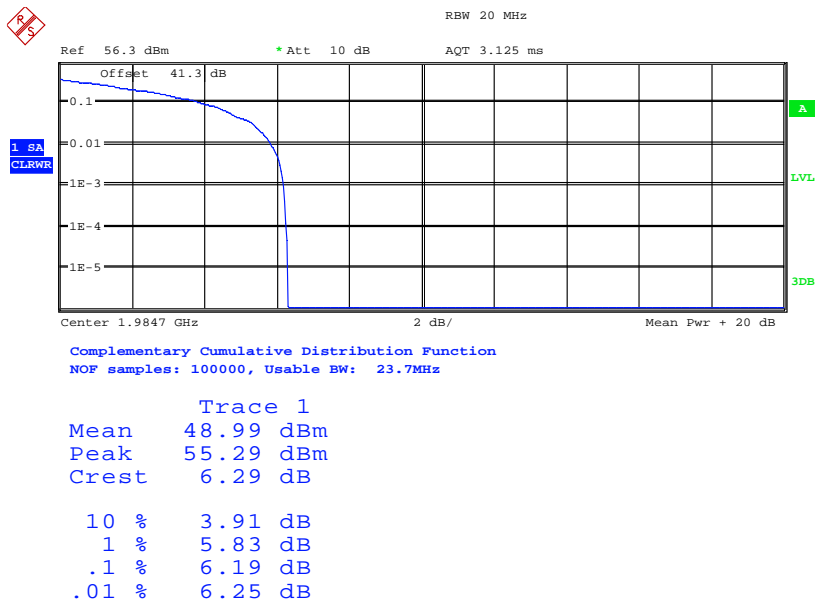

Date: 26.FEB.2013 06:39:28

8-PSK

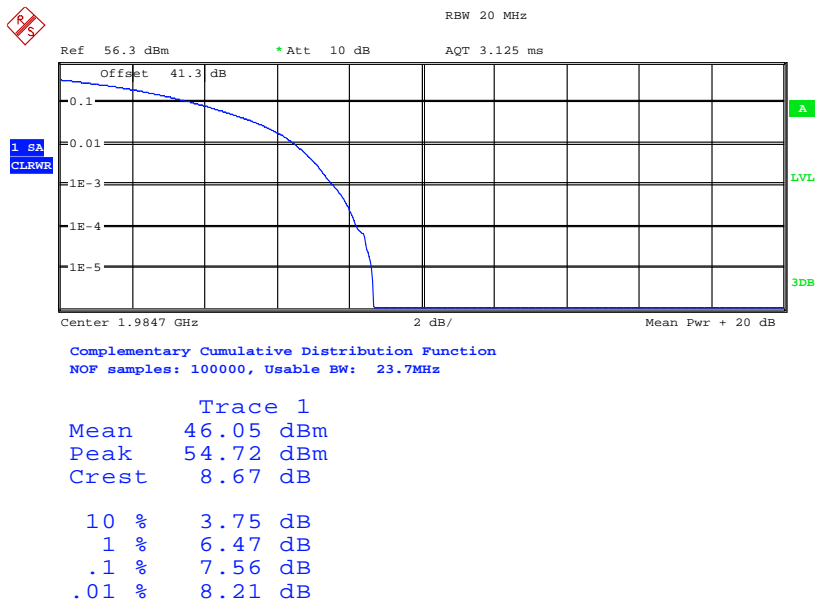

Date: 26.FEB.2013 06:43:46



16QAM

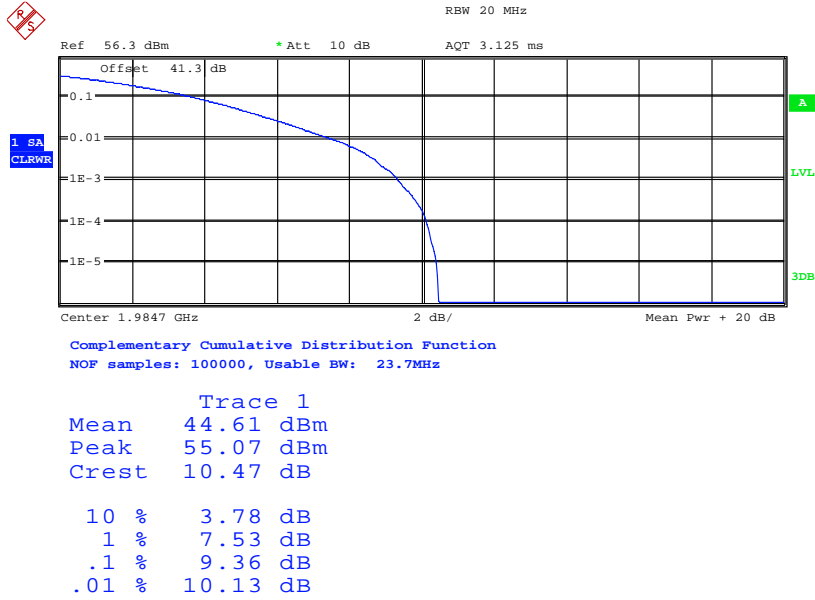

Date: 26.FEB.2013 06:57:32

32QAM

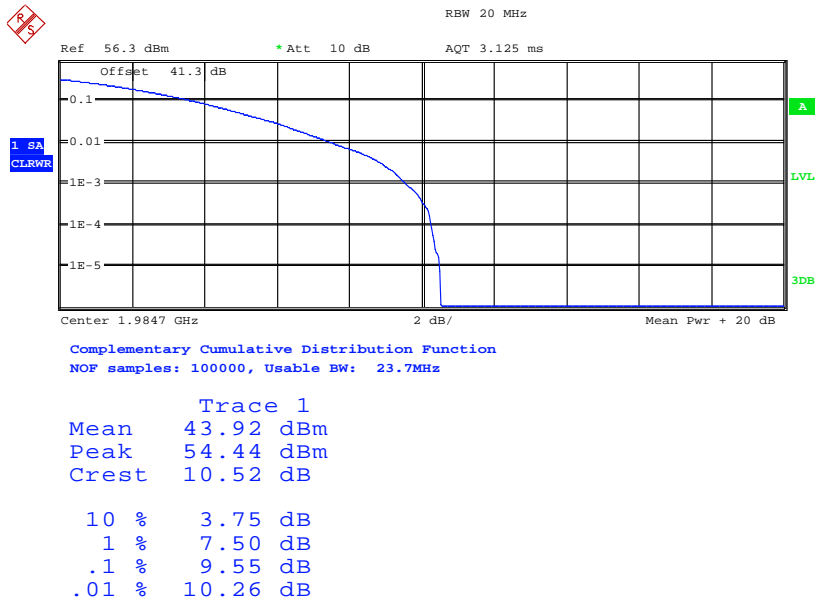

Date: 26.FEB.2013 07:00:52



Product Service

AQPSK

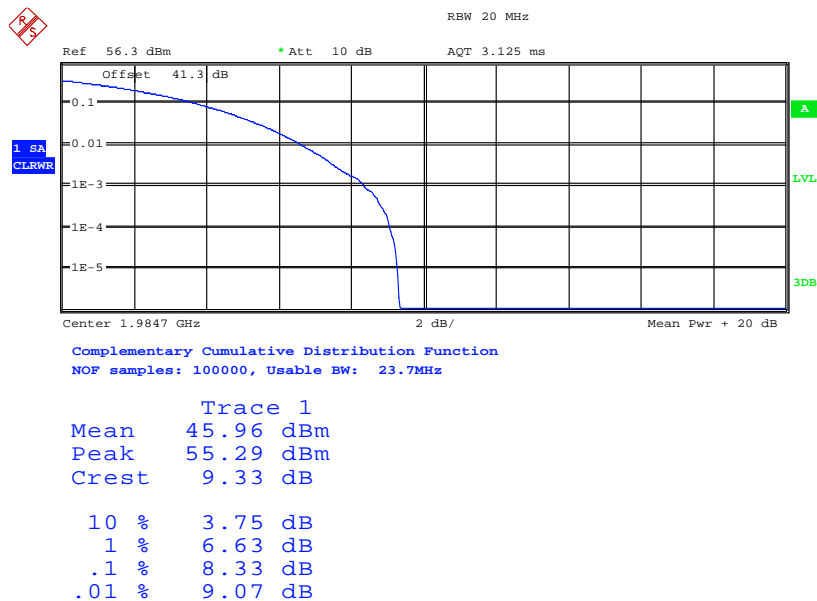

Date: 26.FEB.2013 06:18:27

Limit	13dB
-------	------

Remarks

The Peak – Average ratio does not exceed 13dB at the measured frequencies.



Product Service

2.3 MODULATION CHARACTERISTICS

2.3.1 Specification Reference

FCC CFR 47 Part 2, Clause 2.1047 (d)
Industry Canada RSS-133 Clause 6.2

2.3.2 Equipment Under Test

RRUS 01 B2 / KRC 118 74/2, S/N: D162554351

2.3.3 Date of Test and Modification State

04 March 2013 – Modification State 0

2.3.4 Test Method and Operating Modes

The test was applied in accordance with the test method requirements of FCC CFR 47 Part 2 and Industry Canada RSS-133.

The EUT supports GMSK, 8-PSK, 16QAM, 32QAM and AQPSK modulations.

The test was performed with the EUT in the following configurations and modes of operation:

Configuration 1 - Mode 2

2.3.5 Environmental Conditions

	04 March 2013
Ambient Temperature	23.0°C
Relative Humidity	24.0%



Product Service

2.3.6 Test Results

For the period of test the EUT met the requirements of FCC CFR 47 Part 2 and Industry Canada RSS-133 for Modulation Characteristics.

The test results are shown below

Single Carrier

Configuration 1 - Mode 2

GMSK

GSM / EDGE / EDGE Evolution					
Frequency	ARFCN 661 (1.96 GHz)	Ref Level	50.1 dBm, Att 15 dB	External Att	40 dB
Device Type	BTS Normal, PCS 1900	Trigger	Ext. Offset 1.18 ms	Slot	0 (NB, GMSK)

A: Constellation: Graph

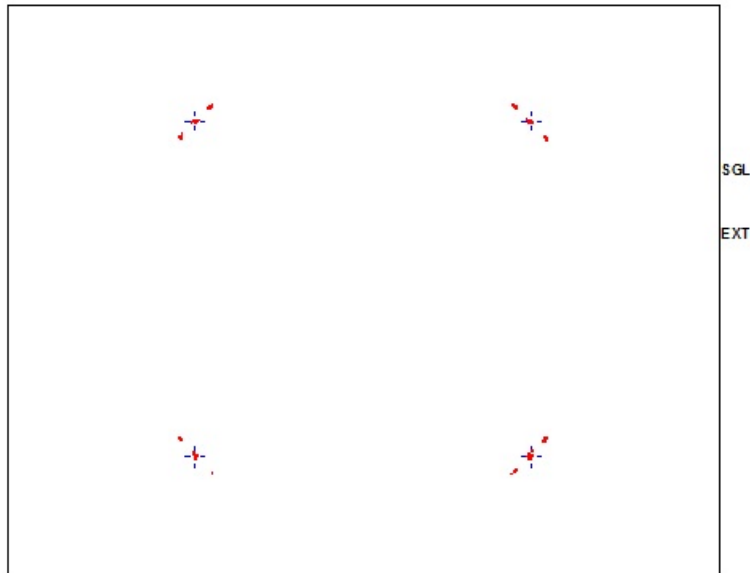

B: Constellation: Modulation Accuracy

		Current	Unit
10/10	EVM	RMS	1.13 %

Date: 4.MAR.2013 09:05:38



Product Service

8-PSK

GSM / EDGE / EDGE Evolution					
Frequency	ARFCN 661 (1.96 GHz)	Ref Level	53.1 dBm, Att 15 dB	External Att	40 dB
Device Type	BTS Normal, PCS 1900	Trigger	Ext. Offset 19.77 Hz	Slot	0 (NB, 8PSK)

A : Constellation: Graph

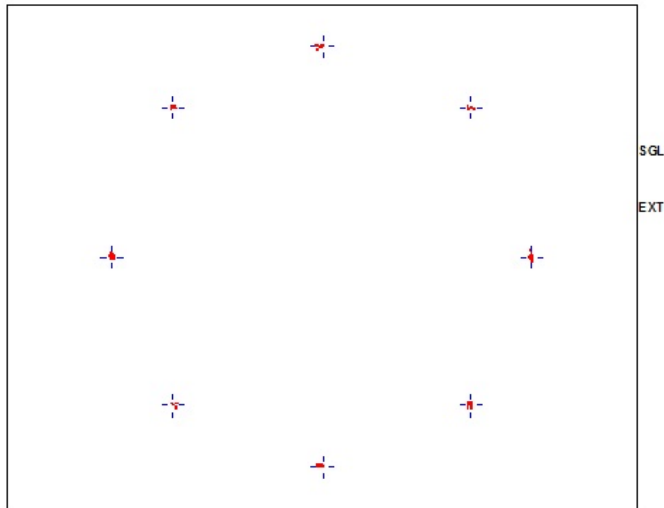

B : Constellation: Modulation Accuracy

		Current	Unit
10/10	EVM	RMS	0.73
			%

Date: 4.MAR.2013 09:04:16

16QAM

GSM / EDGE / EDGE Evolution					
Frequency	ARFCN 661 (1.96 GHz)	Ref Level	54.3 dBm, Att 15 dB	External Att	40 dB
Device Type	BTS Normal, PCS 1900	Trigger	Ext. Offset 19.62 Hz	Slot	0 (NB, 16QAM)

A : Constellation: Graph

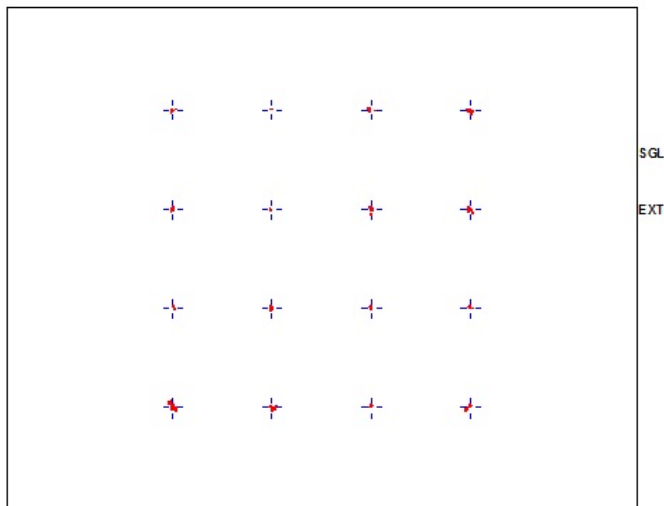

B : Constellation: Modulation Accuracy

		Current	Unit
10/10	EVM	RMS	1.06
			%

Date: 4.MAR.2013 09:01:40



32QAM

GSM / EDGE / EDGE Evolution					
Frequency	ARFCN 661 (1.96 GHz)	Ref Level	54.5 dBm, Att 15 dB	External Att	40 dB
Device Type	BTS Normal, PCS 1900	Trigger	Ext. Offset 2.33 ms	Slot	0 (NB, 32QAM)

A: Constellation: Graph

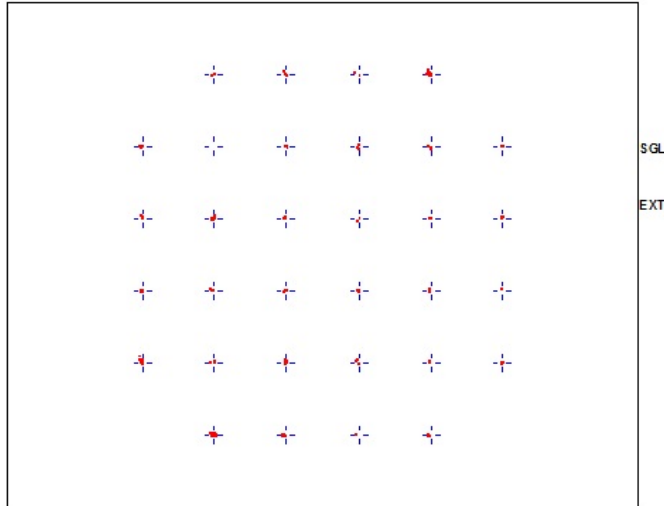

B: Constellation: Modulation Accuracy

10/10			
EVM	RMS	Current	Unit
		0.76	%

Date: 4.MAR.2013 09:00:34

AQPSK

GSM / EDGE / EDGE Evolution					
Frequency	ARFCN 661 (1.96 GHz)	Ref Level	53.3 dBm, Att 15 dB	External Att	40 dB
Device Type	BTS Normal, PCS 1900	Trigger	Ext. Offset 19.77 ms	Slot	0 (NB, AQPSK)

A: Constellation: Graph

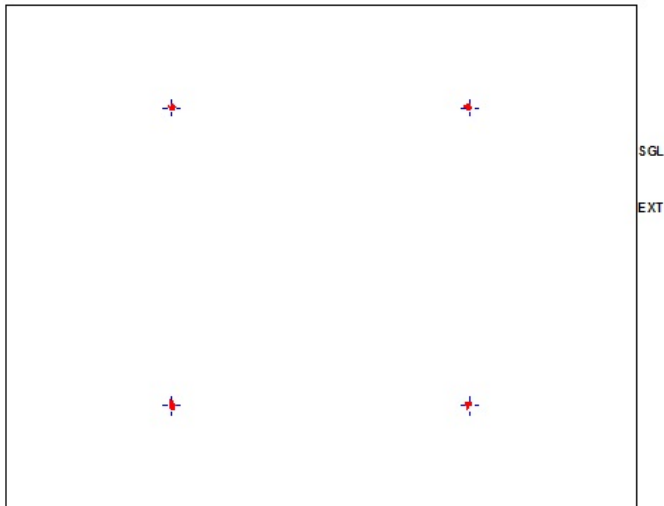

B: Constellation: Modulation Accuracy

10/10			
EVM	RMS	Current	Unit
		0.72	%

Date: 4.MAR.2013 09:10:26



Product Service

2.4 OCCUPIED BANDWIDTH

2.4.1 Specification Reference

FCC CFR 47 Part 2, Clause 2.1049
 FCC CFR 47 Part 24, Clause 24.238 (b)
 Industry Canada RSS-GEN, Clause 4.6.1

2.4.2 Equipment Under Test

RRUS 01 B2 / KRC 118 74/2, S/N: D162554351

2.4.3 Date of Test and Modification State

27 and 28 February 2013 – Modification State 0

2.4.4 Test Equipment Used

The major items of test equipment used for the above tests are identified in Section 3.1.

2.4.5 Test Method and Operating Modes

The test was applied in accordance with the test method requirements of FCC CFR 47 Part 2 and Part 24 and Industry Canada RSS-GEN.

The EUT was transmitting at maximum power, modulated with all timeslot active. Using a resolution bandwidth of 3kHz and a video bandwidth of 30kHz. The occupied bandwidth, that is the frequency bandwidth such that, below its lower and above its upper frequency limits, the mean powers radiated are each equal to 0.5 percent of the total mean power radiated by a given emission.

The test was performed with the EUT in the following configurations and modes of operation:

Configuration 1 - Mode 2

2.4.6 Environmental Conditions

	27 February 2013	28 February 2013
Ambient Temperature	21.0°C	22.0°C
Relative Humidity	20.2%	26.5%



2.4.7 Test Results

For the period of test the EUT met the requirements of FCC CFR 47 Part 2 and Part 24 and Industry Canada RSS-GEN for Occupied Bandwidth.

The test results are shown below

Single Carrier

Configuration 1 - Mode 2

GMSK

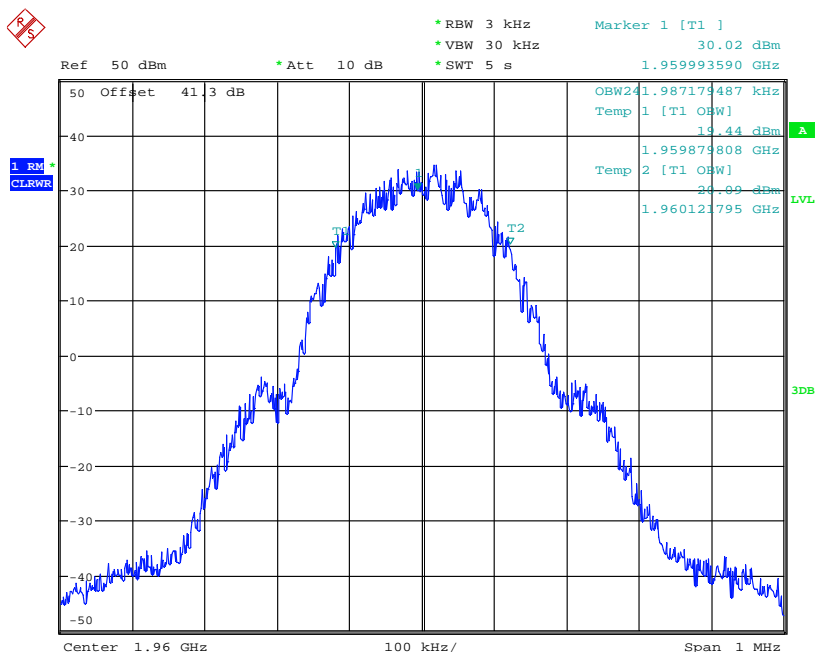

Date: 27.FEB.2013 23:59:26



8-PSK

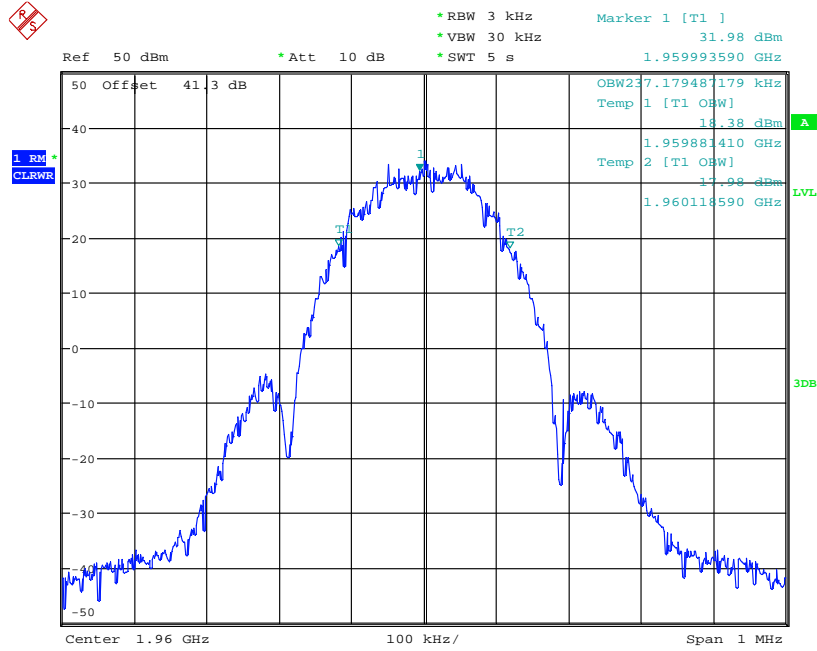

Date: 28.FEB.2013 00:01:50

16QAM

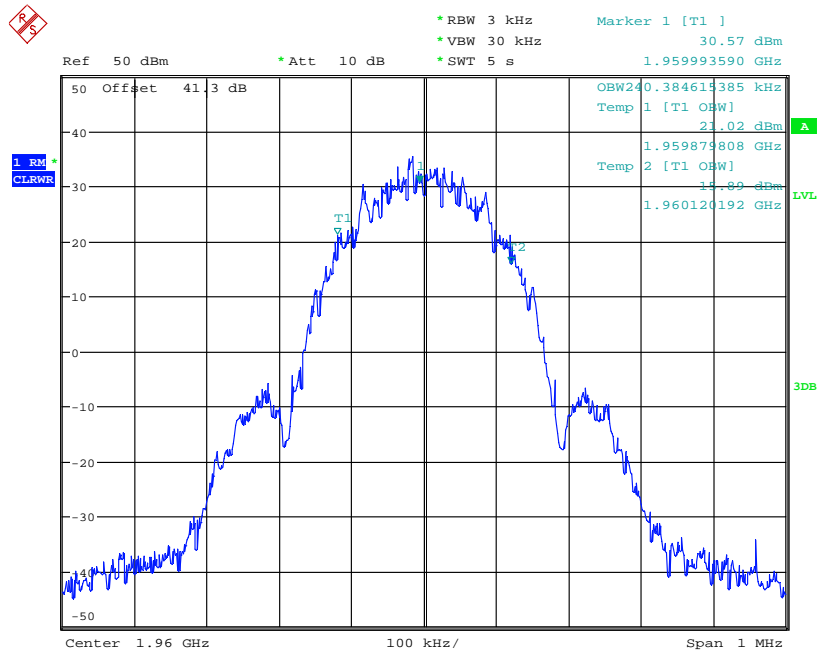

Date: 28.FEB.2013 00:04:05



32QAM

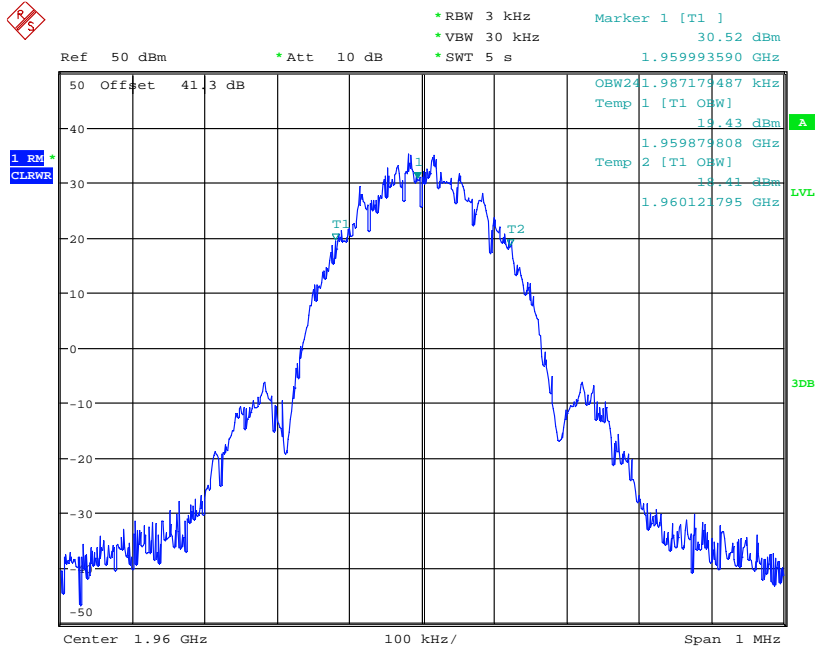

Date: 28.FEB.2013 00:05:12

AQPSK

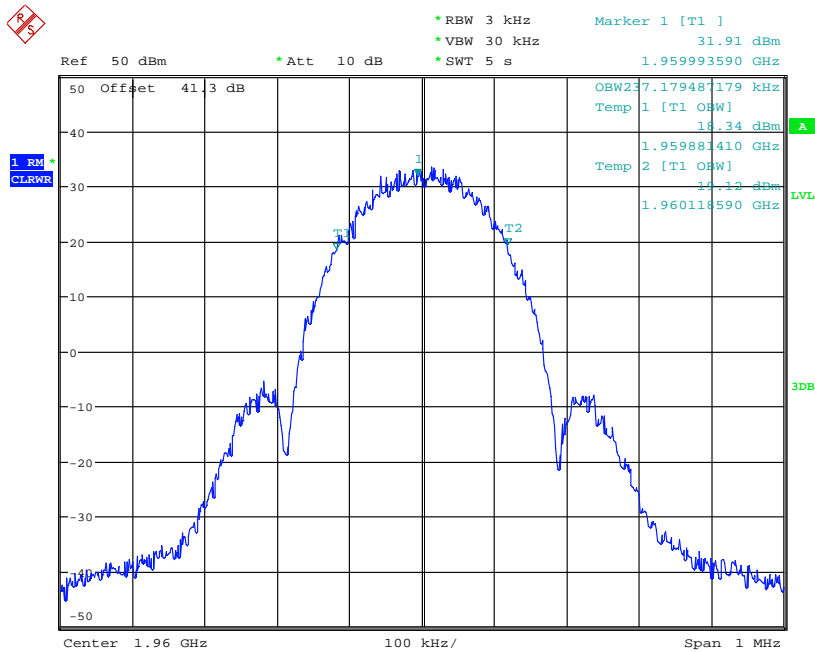

Date: 28.FEB.2013 00:09:56



Product Service

2.5 SPURIOUS EMISSIONS AT ANTENNA TERMINALS (± 1 MHz)

2.5.1 Specification Reference

FCC CFR 47 Part 2, Clause 2.1051
FCC CFR 47 Part 24, Clause 24.238(b)
Industry Canada RSS-133 Clause 6.5

2.5.2 Equipment Under Test

RRUS 01 B2 / KRC 118 74/2, S/N: D162554351

2.5.3 Date of Test and Modification State

28 February, 01 and 25 March 2013 – Modification State 0

2.5.4 Test Equipment Used

The major items of test equipment used for the above tests are identified in Section 3.1.

2.5.5 Test Method and Operating Modes

The test was applied in accordance with the test method requirements of FCC CFR 47 Part 2 and Part 24 and Industry Canada RSS-133.

In accordance with 24.238(b), at least 1% of the emission bandwidth was used for the resolution bandwidths up to 1MHz away from the block edge. A resolution bandwidth of 50kHz was used between 1MHz to 5MHz or higher away from the band edge. As the FCC rules specify a RBW of 1MHz or greater for measurements of emissions > 1MHz away from the band edges, the limit was adjusted with -13dB to -26dBm to compensate for the reduce measurement bandwidth. Spectrum analyser detector was set as RMS.

The path loss measured and entered as a reference level offset.

The EUT was tested at it's maximum power level with all timeslots activated.

The test was performed with the EUT in the following configurations and modes of operation:

Configuration 1 - Mode 1
- Mode 3
- Mode 4'
- Mode 6'
- Mode 7'
- Mode 9'
- Mode 10
- Mode 12



Product Service

2.5.6 Environmental Conditions

	28 February 2013	01 March 2013	25 March 2013
Ambient Temperature	22.0°C	22.0°C	20.8 °C
Relative Humidity	26.5%	46.5%	23.5%

2.5.7 Test Results

For the period of test the EUT met the requirements of FCC CFR 47 Part 2 and Part 24 and Industry Canada RSS-133 for Spurious Emissions Antenna Terminals (± 1 MHz).

Below are the Frequencies the EUT was tested against along with the tested channels.

Remark:

The channel adjacent to the lower and higher band-edge cannot be used. The lowest usable channel is 513 (1930.4MHz), the highest usable channel is 809 (1989.6MHz)

Configuration 1 - Mode 1 and 3

Band Edge Frequency	Edge Test with GMSK modulation Channel No./Frequencies	Edge Test with 8-PSK modulation Channel No./Frequencies
Bottom 1930MHz	Channel: 513 Frequency: 1930.4 MHz	Channel: 513 Frequency: 1930.4 MHz
Top 1990MHz	Channel: 809 Frequency: 1989.6 MHz	Channel: 809 Frequency: 1989.6 MHz

Configuration 1 - Mode 4' and 6'

Band Edge Frequency	Edge Test with GMSK modulation Channel No./Frequencies	Edge Test with 8-PSK modulation Channel No./Frequencies
Bottom 1930MHz	Channel: 513 & 521 Frequency: 1930.4 MHz & 1932.0MHz	Channel: 513 & 521 Frequency: 1930.4 MHz & 1932.0MHz
Top 1990MHz	Channel: 801 & 809 Frequency: 1988.0MHz & 1989.6MHz	Channel: 801 & 809 Frequency: 1988.0MHz & 1989.6MHz



Configuration 1 - Mode 7' and 9'

Band Edge Frequency	Edge Test with GMSK modulation Channel No./Frequencies	Edge Test with 8-PSK modulation Channel No./Frequencies
Bottom 1930MHz	Channel: 513 & 521 & 529 Frequency: 1930.4 MHz & 1932.0MHz & 1933.6MHz	Channel: 513 & 521 & 529 Frequency: 1930.4 MHz & 1932.0MHz & 1933.6MHz
Top 1990MHz	Channel: 793 & 801 & 809 Frequency: 1986.4MHz & 1988.0MHz & 1989.6MHz	Channel: 793 & 801 & 809 Frequency: 1986.4MHz & 1988.0MHz & 1989.6MHz

Configuration 1 - Mode 10 and 12

Band Edge Frequency	Edge Test with GMSK modulation Channel No./Frequencies	Edge Test with 8-PSK modulation Channel No./Frequencies
Bottom 1930MHz	Channel: 513 & 529 & 545 & 562 Frequency: 1930.4MHz + 1933.6MHz + 1936.8MHz + 1940.2MHz	Channel: 513 & 529 & 545 & 562 Frequency: 1930.4MHz + 1933.6MHz + 1936.8MHz + 1940.2MHz
Top 1990MHz	Channel: 760 & 777 & 793 & 809 Frequency: 1979.8MHz + 1983.2MHz + 1986.4MHz + 1989.6MHz	Channel: 760 & 777 & 793 & 809 Frequency: 1979.8MHz + 1983.2MHz + 1986.4MHz + 1989.6MHz

The channels shown in the table above are the minimum and maximum channels that can be used in the authorised frequency ranges to maintain compliance. Channels used outside of those stated and power levels used beyond those stated in the table exceed the specification limits, thus they cannot be used.

The channels outside of those shown in the table above were not tested at lower power levels to determine a level at which compliance would be achieved. Therefore, to maintain compliance, only the channels shown in the table above shall be used.



The test results are shown below

Single Carrier

GMSK

Configuration 1 - Mode 1

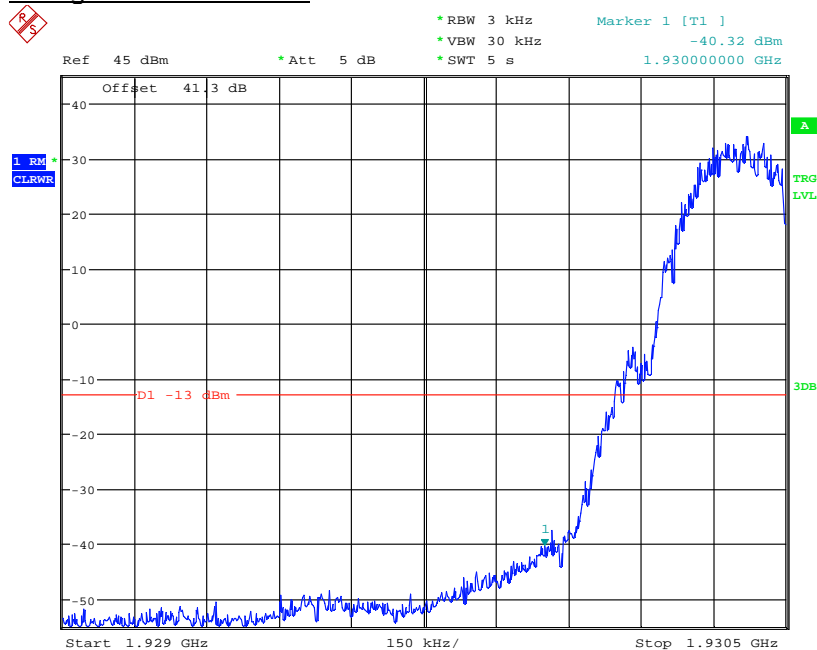

Date: 28.FEB.2013 03:07:54

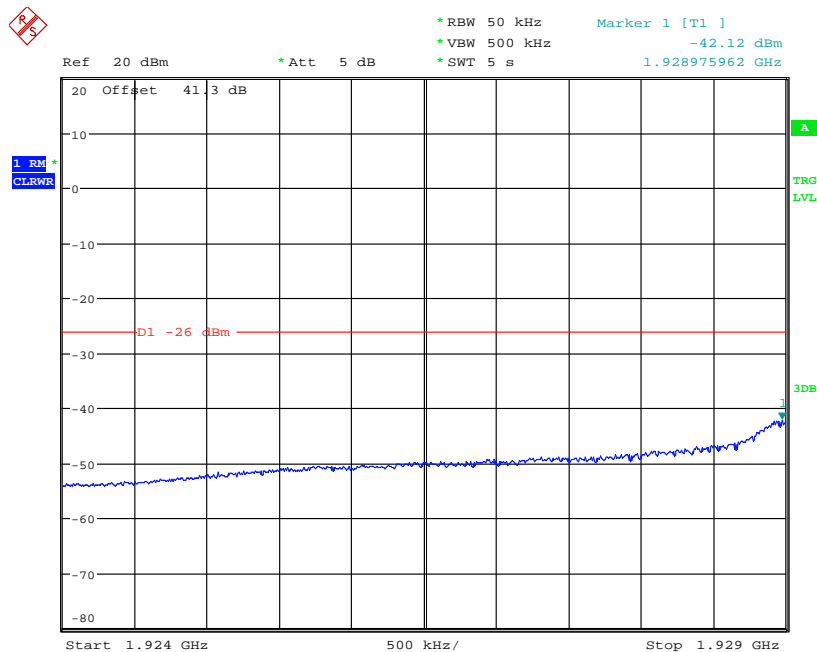

Date: 28.FEB.2013 03:06:57



Configuration 1 – Mode 3



Date: 28.FEB.2013 01:17:53

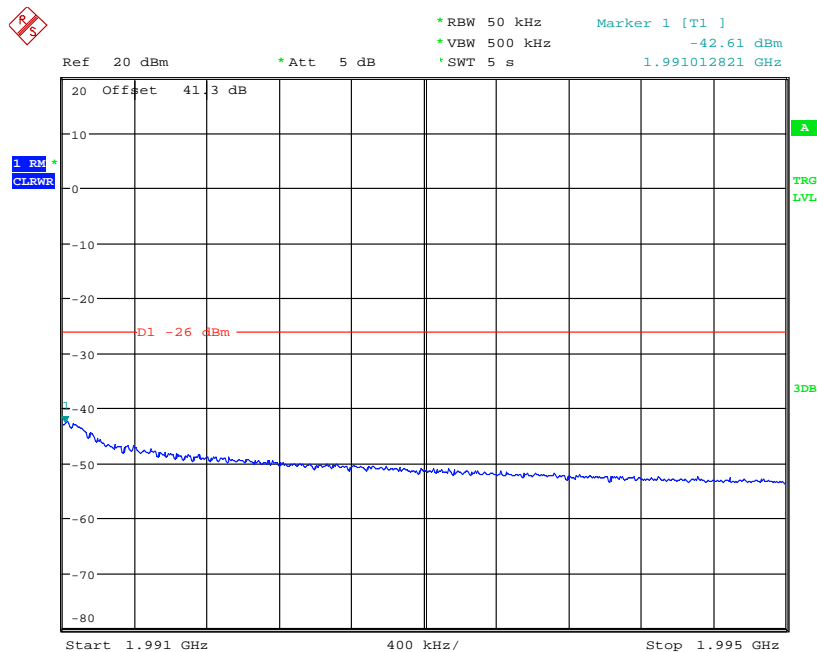

Date: 28.FEB.2013 01:16:39



8-PSK

Configuration 1 - Mode 1

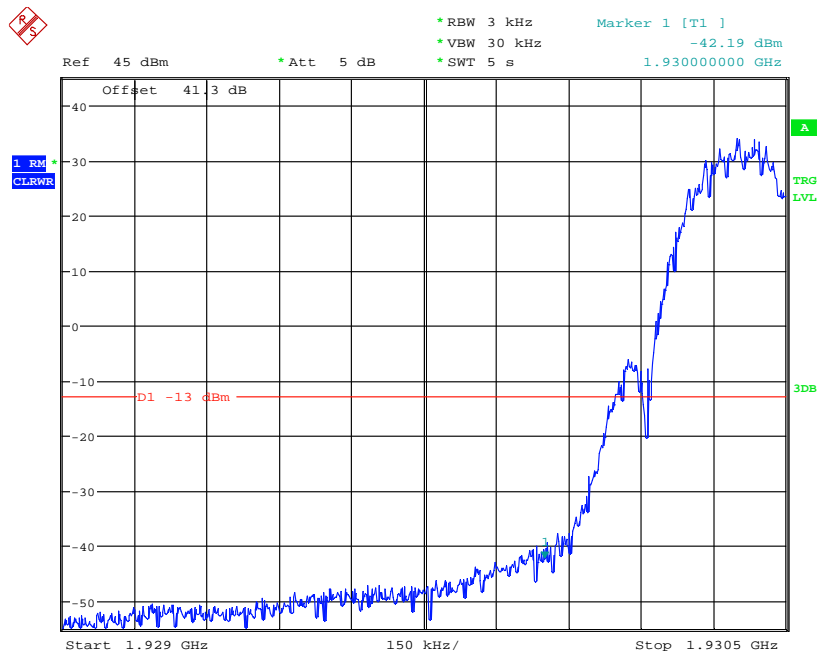

Date: 28.FEB.2013 03:01:33

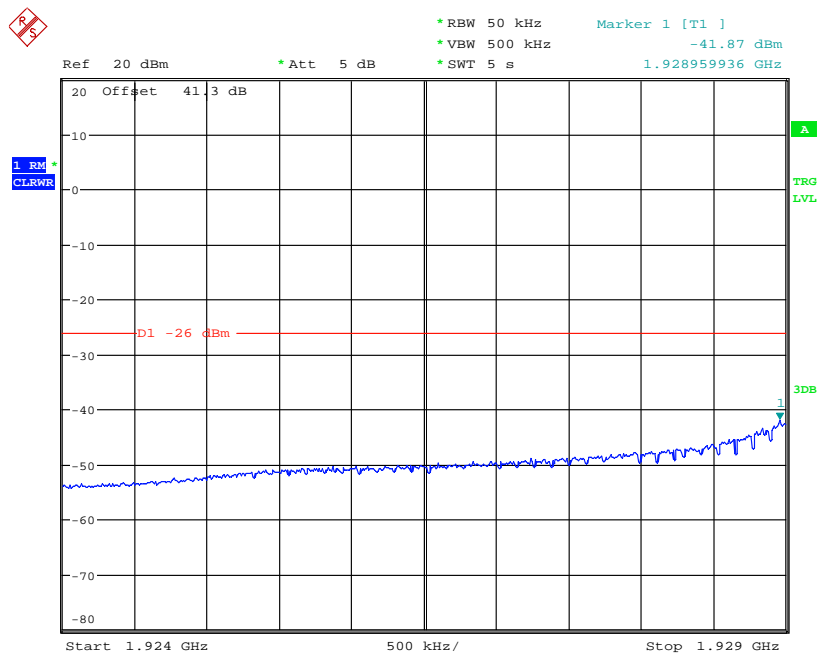

Date: 28.FEB.2013 03:04:35



Product Service

Configuration 1 - Mode 3

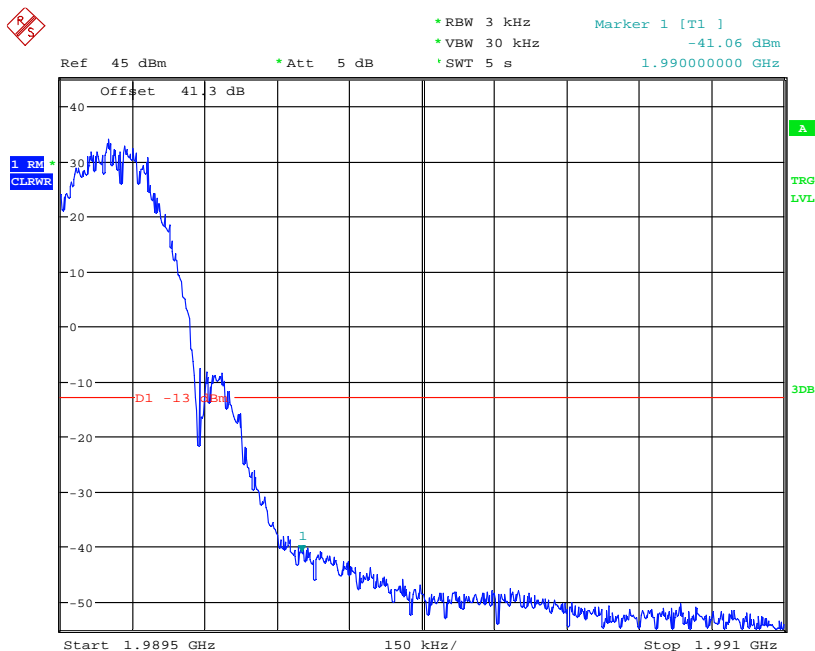

Date: 28.FEB.2013 01:12:49

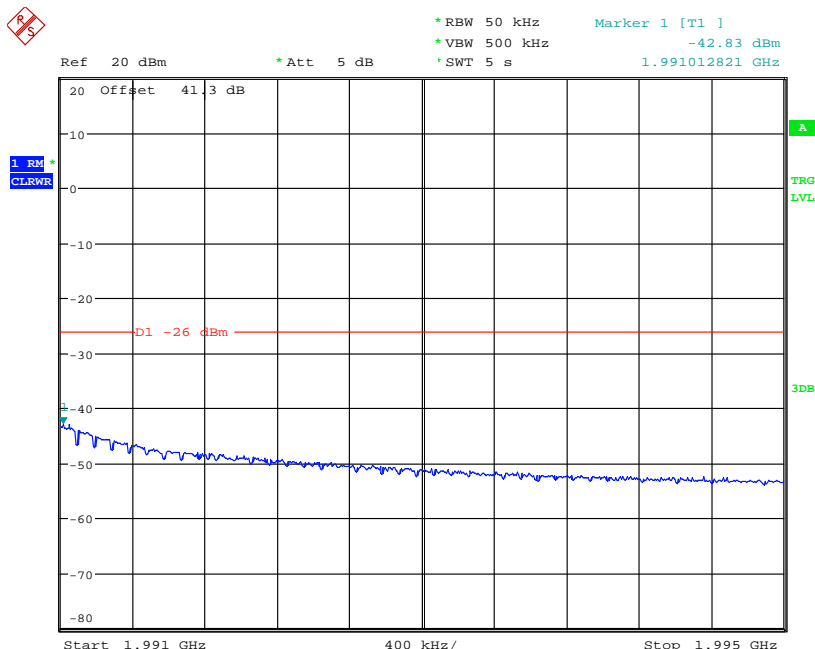

Date: 28.FEB.2013 01:15:15



Product Service

Multi Carrier (1x2)

GMSK

Configuration 1 - Mode 4'

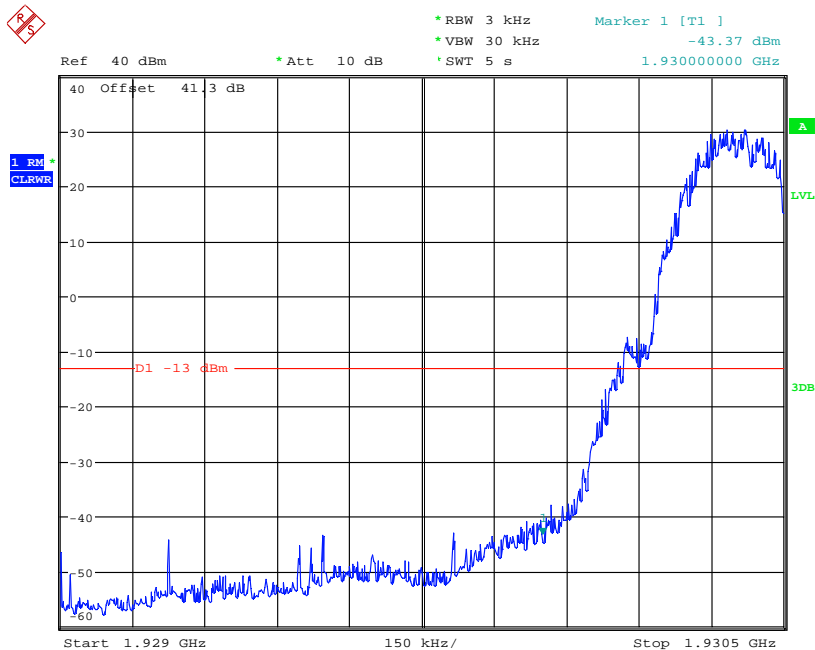

Date: 1.MAR.2013 03:58:18

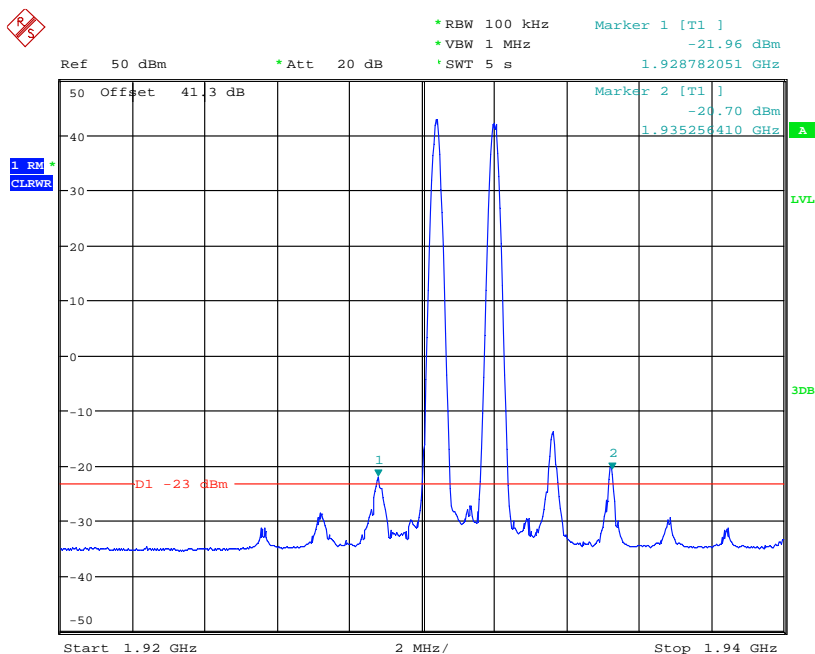

Date: 1.MAR.2013 04:26:19



Product Service

The Channel Power for 1928.88MHz is -18.98dBm

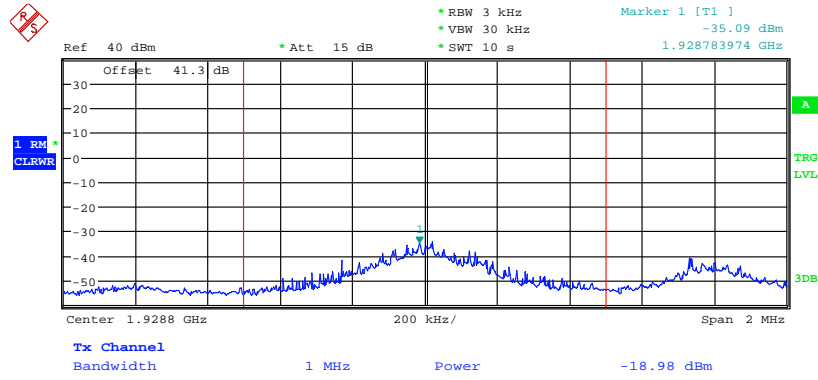

Date: 1.MAR.2013 05:53:52



Configuration 1 - Mode 6'

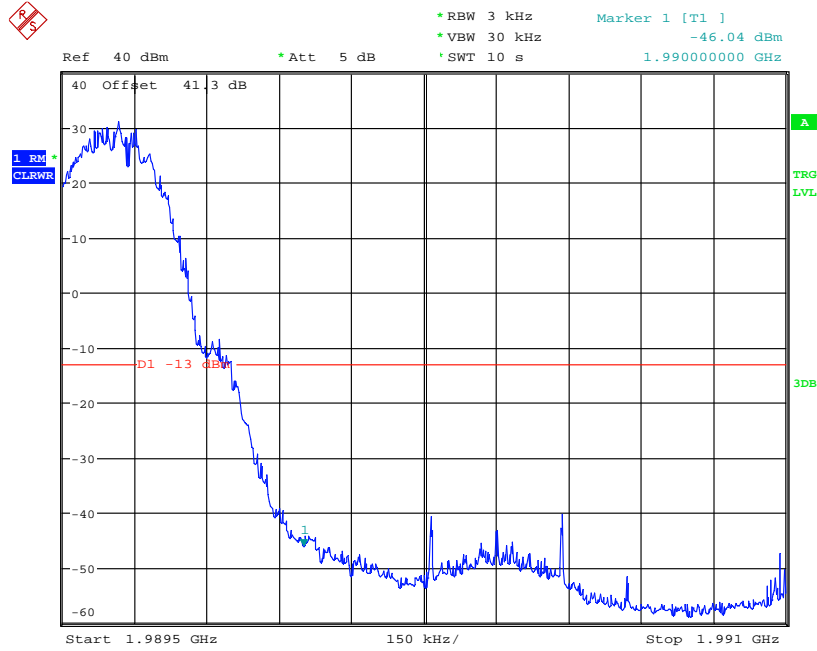

Date: 1.MAR.2013 05:35:22

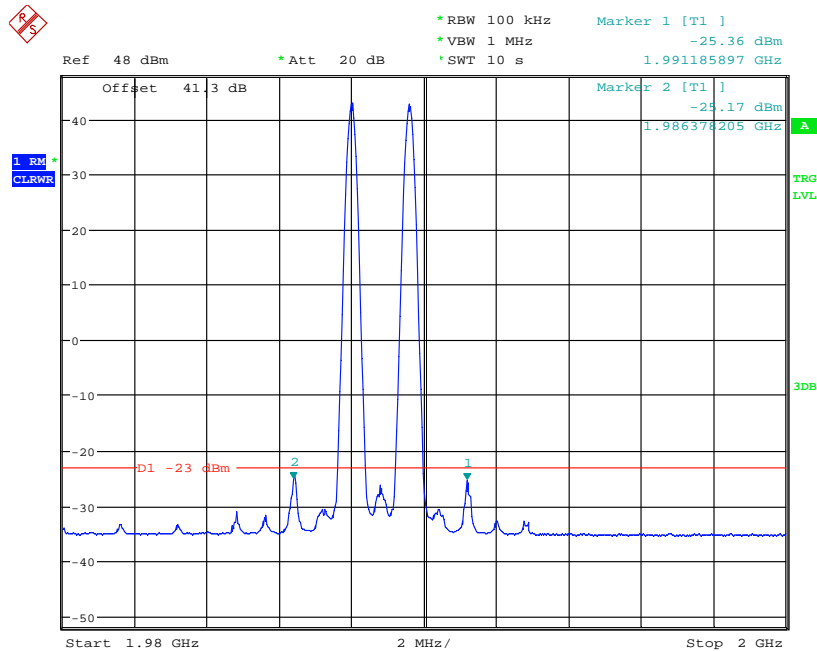

Date: 1.MAR.2013 05:37:57



8-PSK

Configuration 1 - Mode 4'

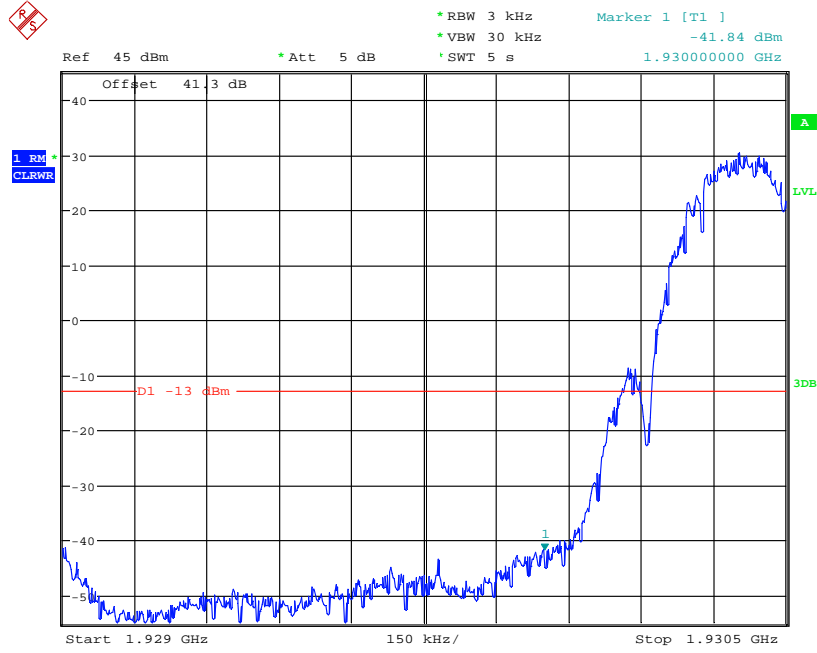

Date: 1.MAR.2013 04:13:15

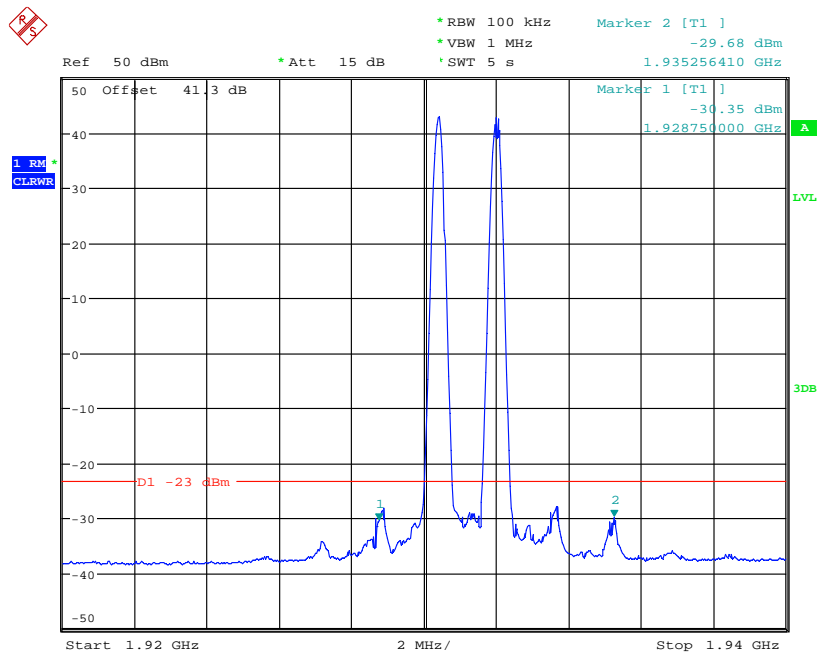

Date: 1.MAR.2013 04:18:40



Configuration 1 - Mode 6'



Date: 1.MAR.2013 05:23:54

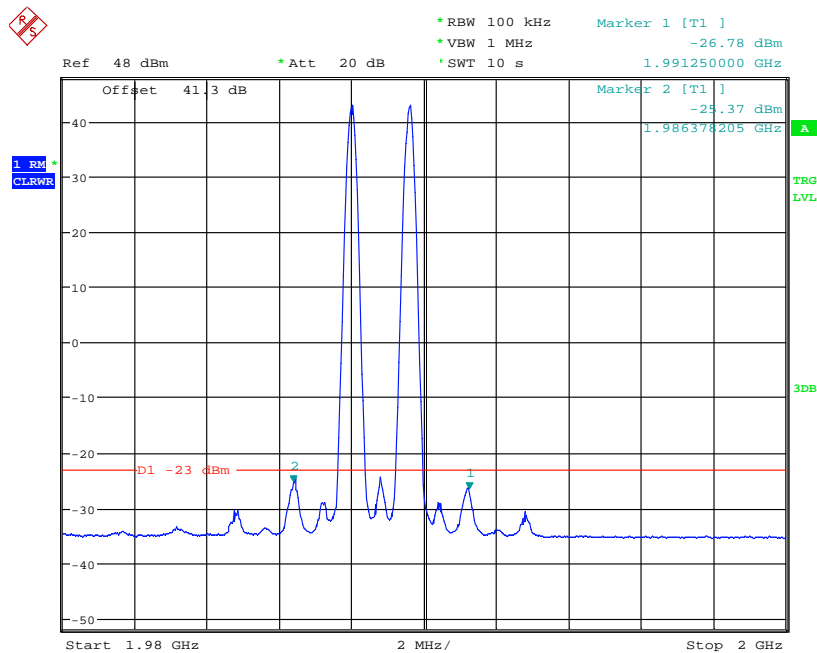

Date: 1.MAR.2013 05:40:31



The Channel Power for 1928.78MHz is -17.57dBm

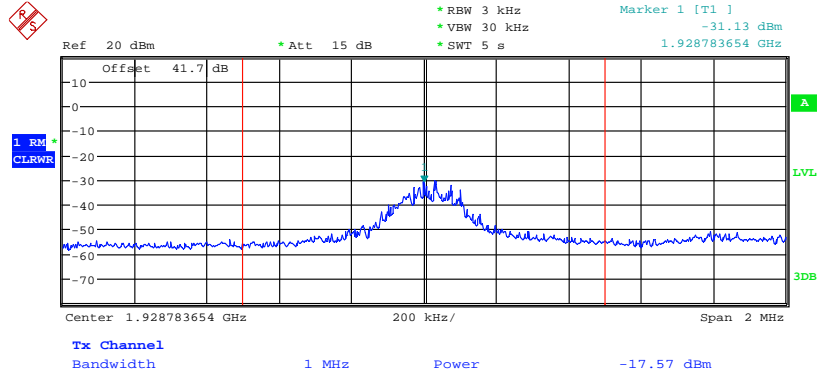

Date: 25.MAR.2013 07:10:15

Configuration 1 - Mode 9'

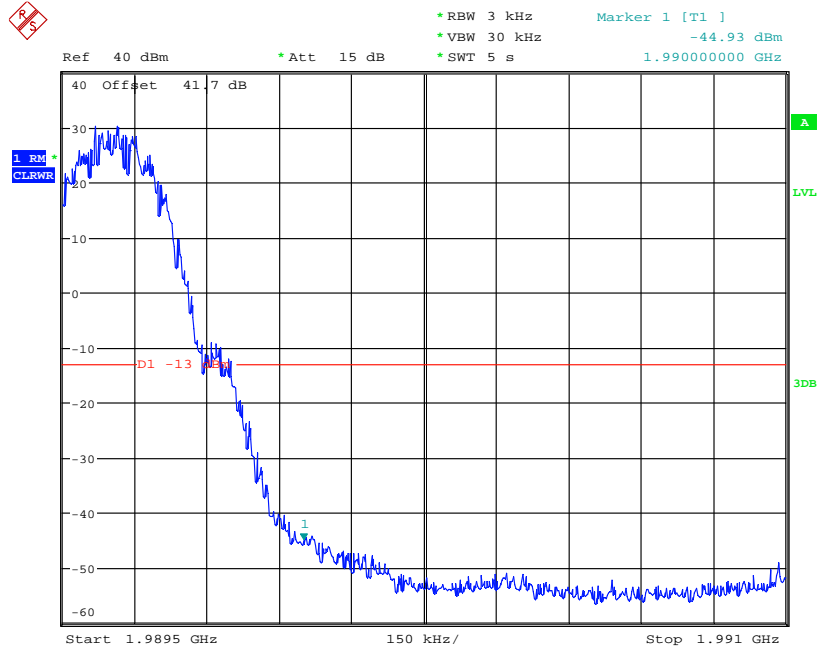

Date: 25.MAR.2013 05:29:00

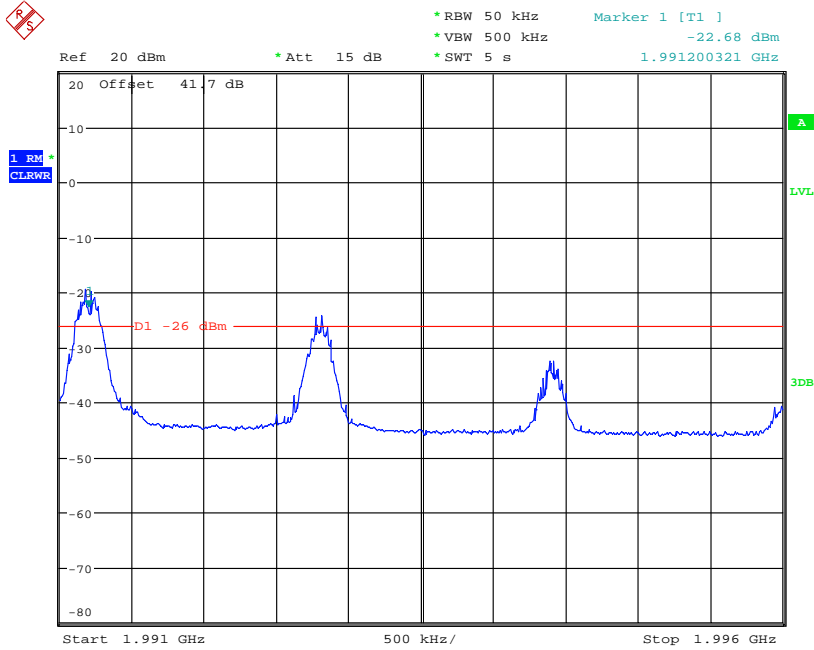

Date: 25.MAR.2013 05:29:42

The Channel Power for 1991.2MHz is -16.41dBm

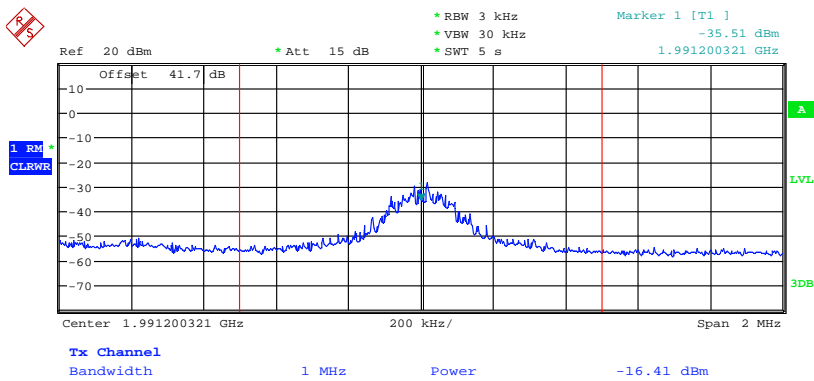

Date: 25.MAR.2013 05:31:03



8-PSK

Configuration 1 - Mode 7'

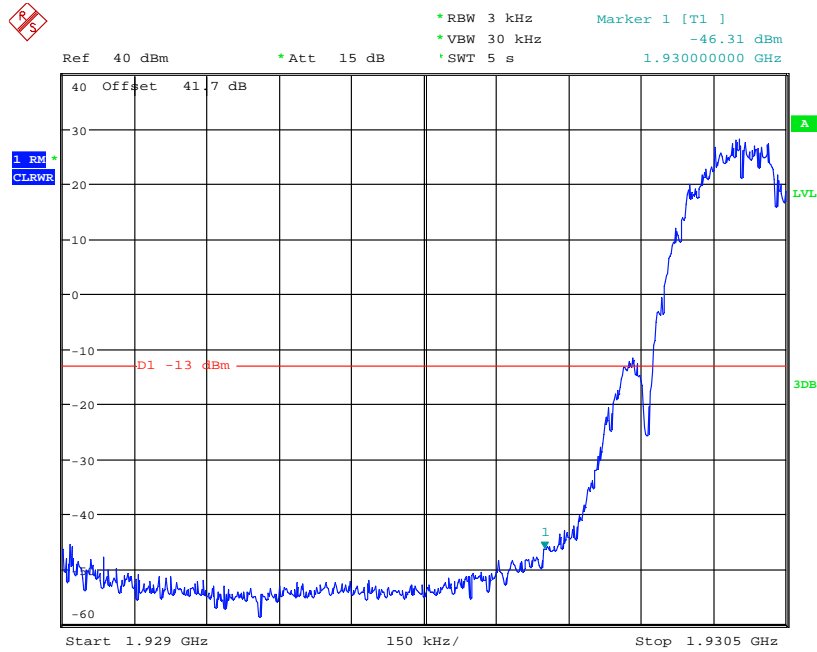

Date: 25.MAR.2013 05:20:44

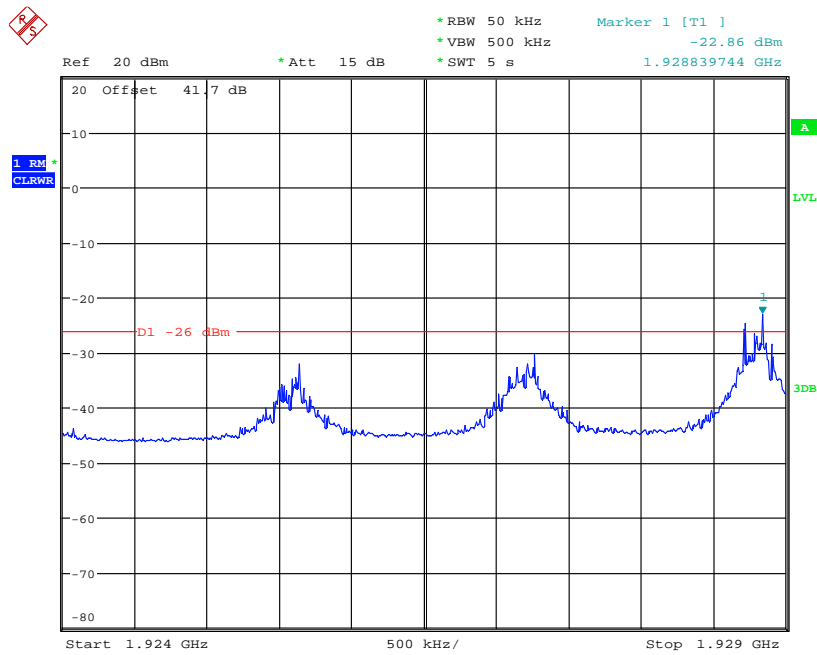

Date: 25.MAR.2013 05:21:46



The Channel Power for 1928.8MHz is -20.98dBm

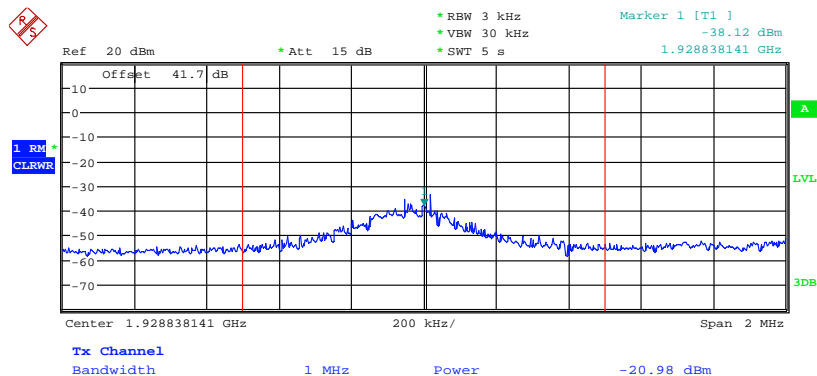

Date: 25.MAR.2013 07:20:57

Configuration 1 - Mode 9'

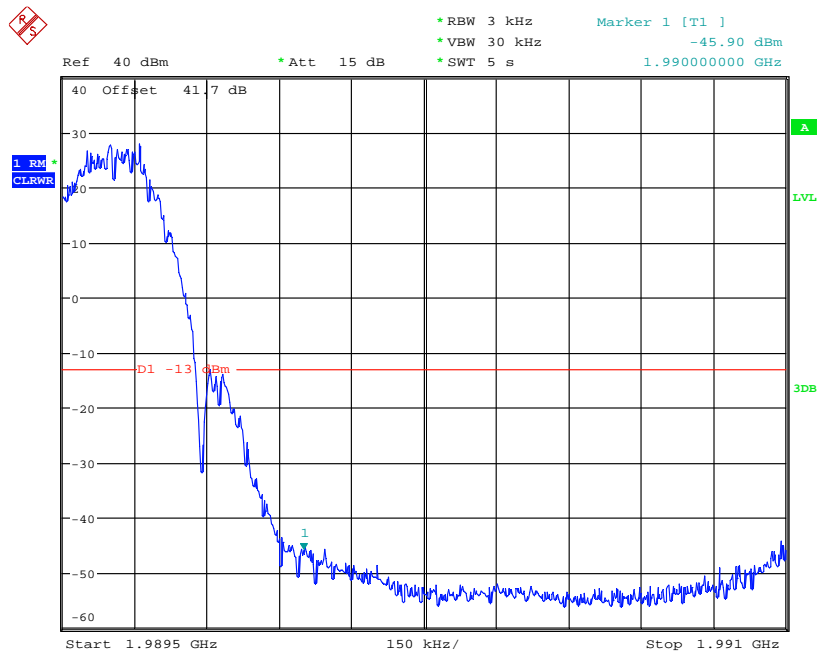

Date: 25.MAR.2013 05:25:41



Product Service

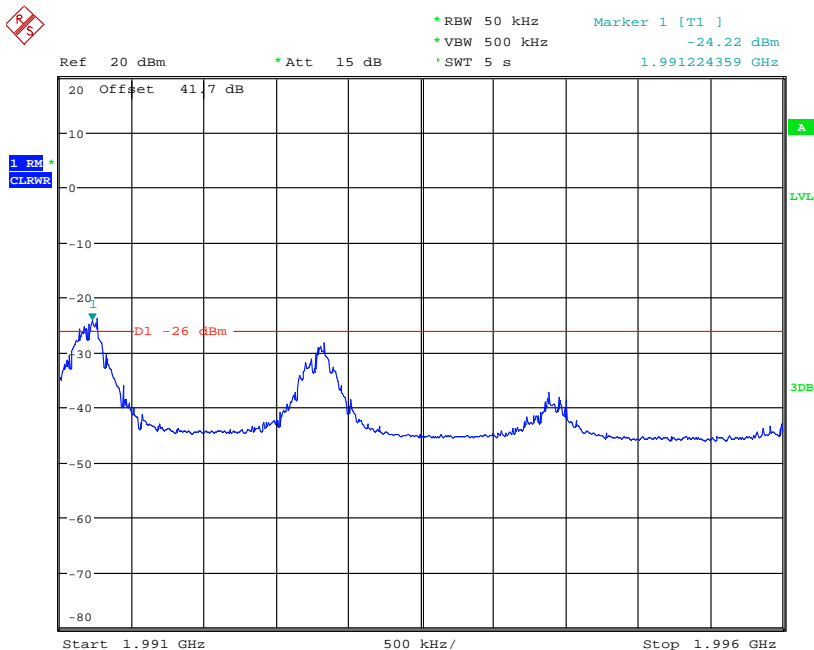

Date: 25.MAR.2013 05:26:34

The Channel Power for 1991.2MHz is -19.22dBm

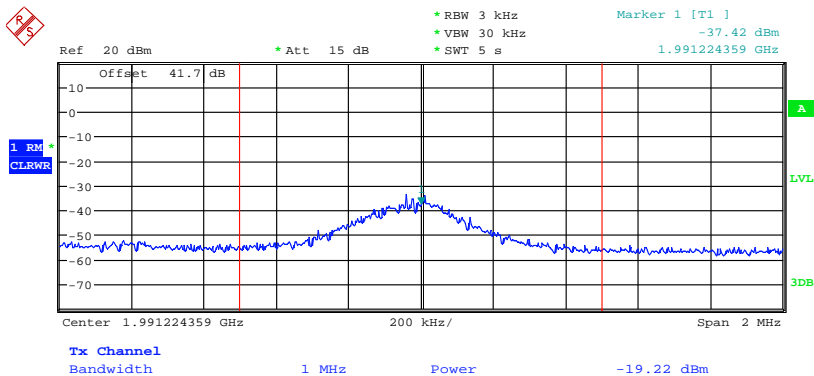

Date: 25.MAR.2013 05:27:32



Multi Carrier (1x4)

GMSK

Configuration 1 - Mode 10

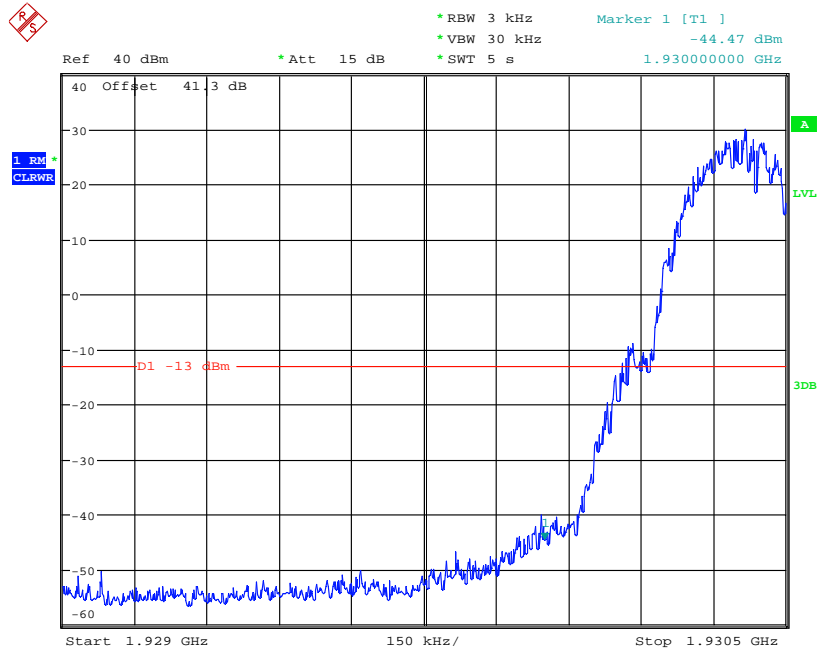

Date: 1.MAR.2013 01:11:34

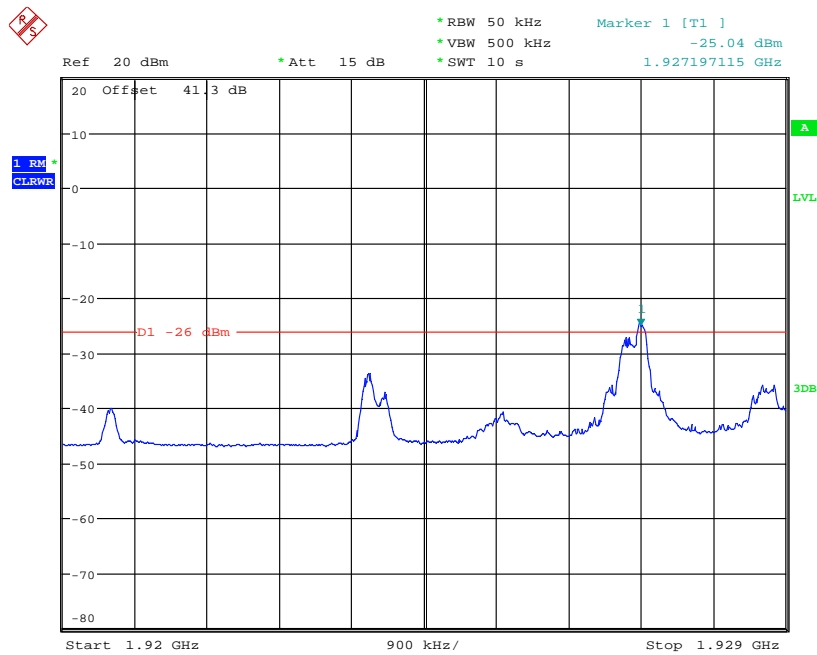

Date: 1.MAR.2013 01:29:28



The Channel Power for 1927.2MHz is -17.63dBm

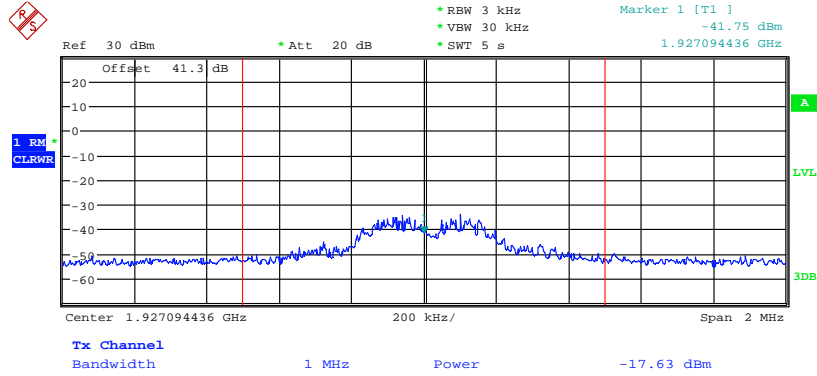

Date: 1.MAR.2013 01:33:19

Configuration 1 - Mode 12

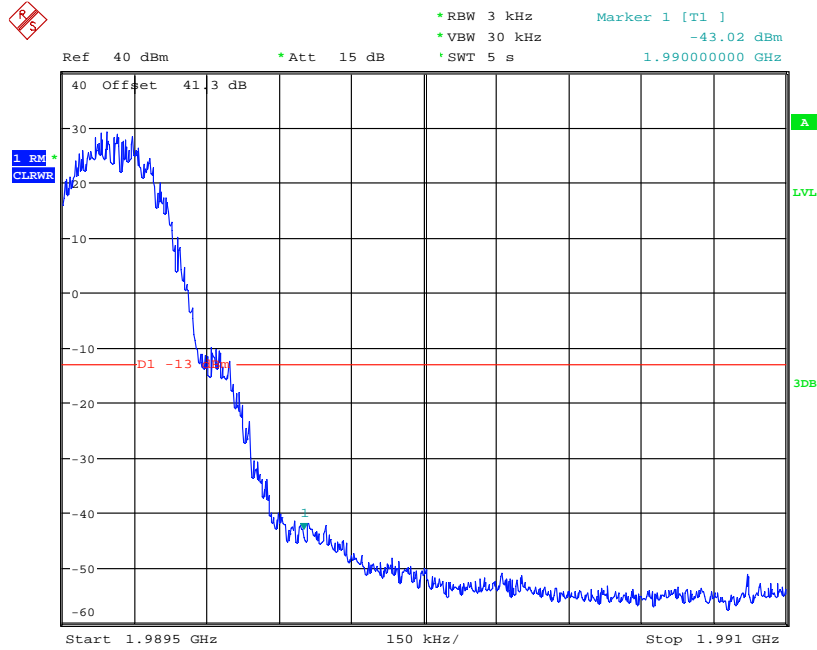

Date: 1.MAR.2013 01:08:06

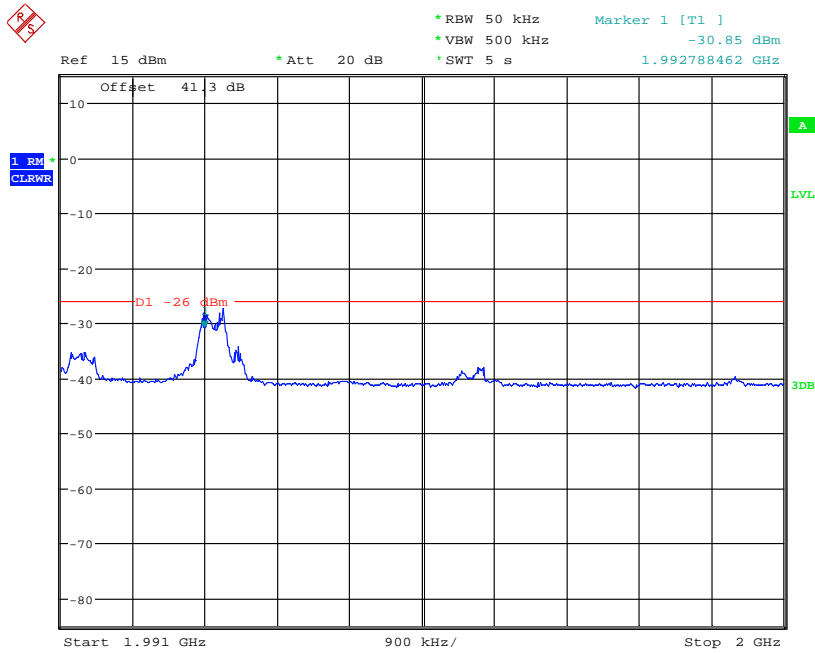

Date: 1.MAR.2013 01:07:01

Limit

The power of any emission outside the frequency band shall be attenuated below the transmitter power (P) by at least $43 + 10\log P$ dB.



Product Service

2.6 RADIATED SPURIOUS EMISSIONS

2.6.1 Specification Reference

FCC CFR 47 Part 2, Clause 2.1053
FCC CFR 47 Part 24, Clause 24.238 (a)
Industry Canada RSS-133, Clause 6.5

2.6.2 Equipment Under Test

RRUS 01 B2 / KRC 118 74/2, S/N: D162554351

2.6.3 Date of Test and Modification State

12 and 13 March 2013 – Modification State 0

2.6.4 Test Equipment Used

The major items of test equipment used for the above tests are identified in Section 3.1.

2.6.5 Test Method and Operating Modes

The test was applied in accordance with the test method requirements of FCC CFR 47 Part 2 and Part 24 and Industry Canada RSS-133.

A preliminary profile of the Spurious Radiated Emissions was obtained by operating the EUT on a remotely controlled turntable within the chamber. Measurements of emissions from the EUT were obtained with the Measurement Antenna in both Horizontal and Vertical Polarisation.

Emissions identified within the range 30MHz – 25GHz were then formally measured using a Peak detector as the worst case.

In the frequency Range 30MHz – 25GHz, the measurement was performed with a resolution bandwidth of 1MHz.

The measurements were performed at a 3m distance unless otherwise stated.

The limits for Spurious Emissions have been calculated, as shown below using the following formula:

Field Strength of Carrier - $(43 + 10\text{Log}(P))$ dB

Where:

Field Strength is measured in dB μ V/m

P is measured Transmitter Power in Watts



Determination of Spurious Emission Limit

As the EUT does not have an integral antenna, the field strength of the carrier has been calculated assuming that the power is to be fed to a half-wave tuned dipoles as per 2.1053 (a).

$$E_{(v/m)} = (30 \times G_i \times P_o)^{0.5} / d$$

Where G_i is the antenna gain of ideal half-wave dipoles,
 P_o is the power out of the transceiver in W,
 d is the measurement distance in meter.

Therefore at 3m measurement distance the field strength using the lowest transceiver output power would be:

$$E_{(v/m)} = (30 \times 1.64 \times 22.8)^{0.5} / 3 = 11.16V/m = 141.0dB\mu V/m$$

As per 24.238 (a) the spurious emission must be attenuated by $43 + 10\log(P_o)$ dB this gives:

$$43 + 10\log(22.8) = 56.6dB$$

Therefore the limit at 3m measurement distance is:

$$141.0 - 56.6 = 84.4 \text{ dB}\mu V/m$$

This limit has been used to determine Pass or Fail for the harmonics measured and detailed in the following results.

The test was performed with the EUT in the following configurations and modes of operation:

- Configuration 1 - Mode 1
 - Mode 2
 - Mode 3
 - Mode 6
 - Mode 12

2.6.6 Environmental Conditions

	12 March 2013	13 March 2013
Ambient Temperature	24.0°C	25.8°C
Relative Humidity	32.5%	30.0%



2.6.7 Test Results

For the period of test the EUT met the requirements of FCC CFR 47 Part 2 & Part 24 and Industry Canada RSS-133 for Radiated Spurious Emissions.

The test results are shown below

Note: Only the worst case results plots have been included as all of the emissions are greater than 15dB below the limit. A set of plots have been included to show the measurement system noise floor.

Single Carrier

GMSK

Configuration 1 – Mode 2

No emissions were detected within 15dB of the limit.

8-PSK

Configuration 1 – Mode1, 2 and 3

No emissions were detected within 15dB of the limit.

16QAM

Configuration 1 – Mode 2

No emissions were detected within 15dB of the limit.

32QAM

Configuration 1 – Mode 2

No emissions were detected within 15dB of the limit.

AQPSK

Configuration 1 – Mode 2

No emissions were detected within 15dB of the limit.



Product Service

Multi Carrier (1x2)

8-PSK

Configuration 1 - Mode 6

30MHz – 1GHz

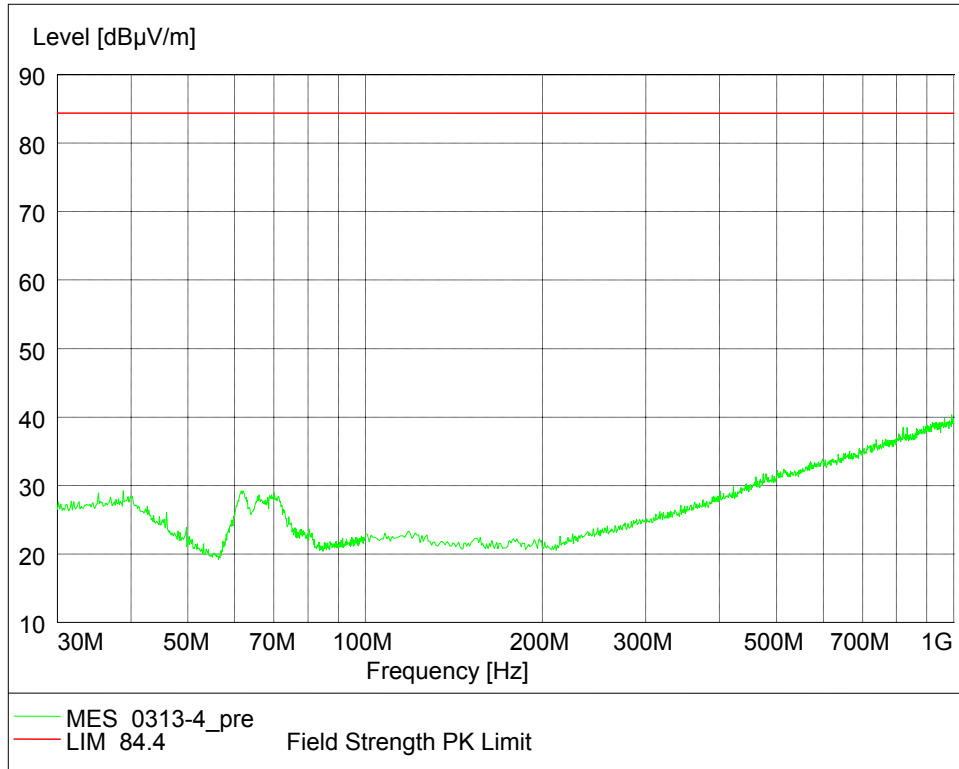



1GHz - 18GHz

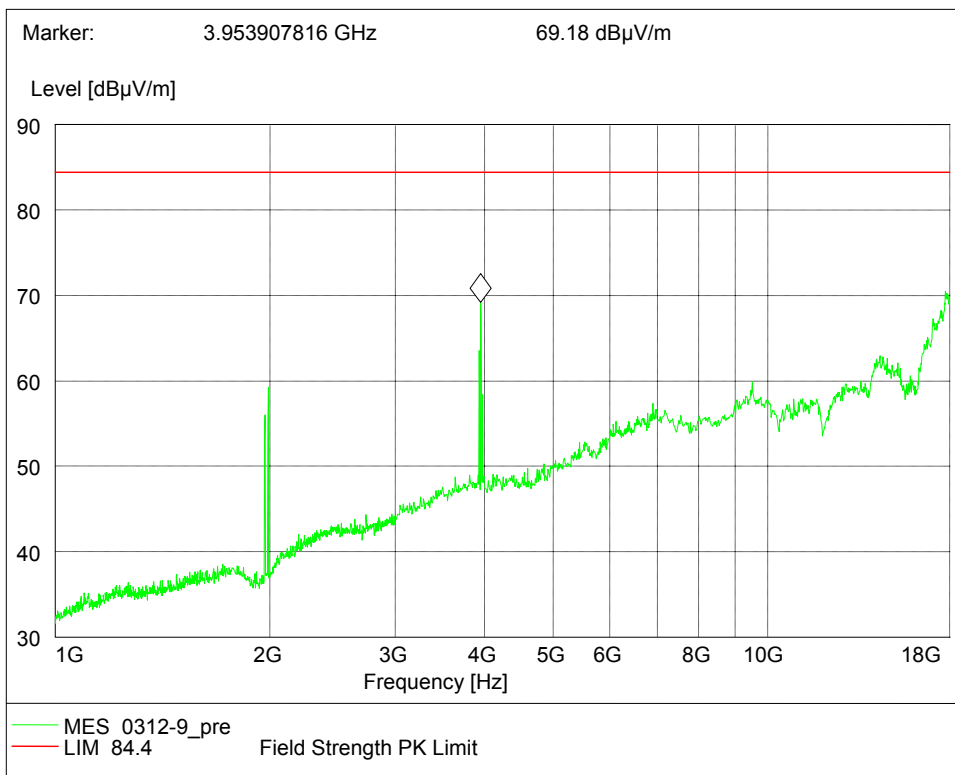

18GHz - 25GHz

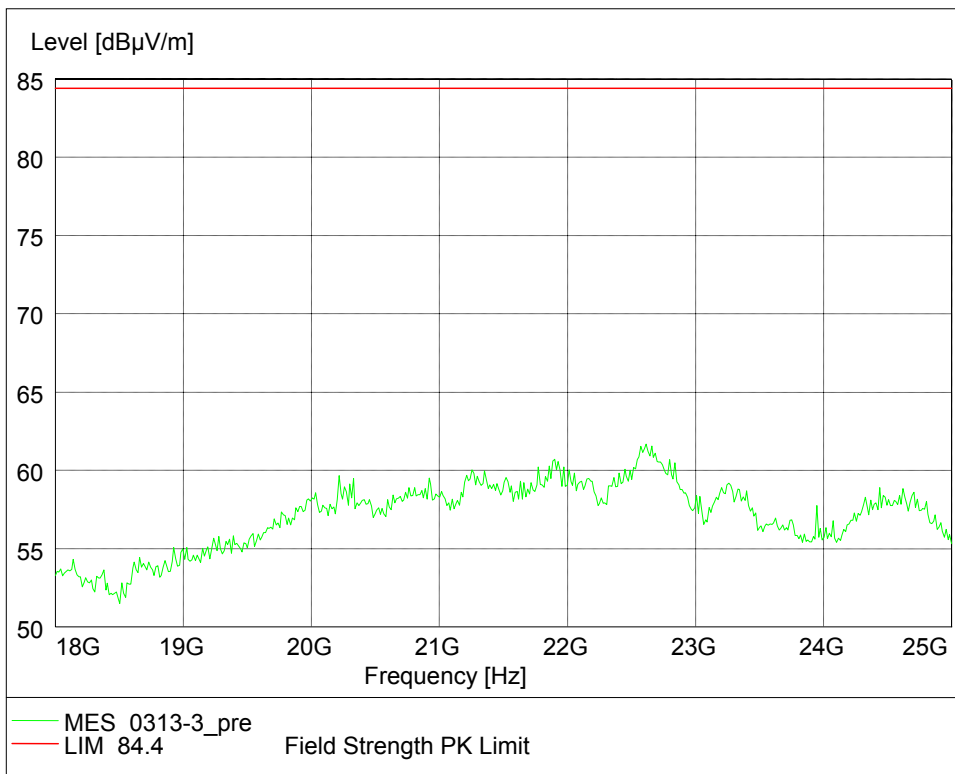



Product Service

Multi Carrier (1x4)**8-PSK**Configuration 1 - Mode 9

No emissions were detected within 20dB of the limit.

Limit	-13dBm or 84.4dB μ V/m
-------	----------------------------

Remarks

The EUT does not exceed -13dBm or 84.4dB μ V/m at the measured frequencies.



Product Service

2.7 CONDUCTED SPURIOUS EMISSIONS

2.7.1 Specification Reference

FCC CFR 47 Part 2, Clause 2.1051
FCC CFR 47 Part 24, Clause 24.238 (a)
Industry Canada RSS-133, Clause 6.5

2.7.2 Equipment Under Test

RRUS 01 B2 / KRC 118 74/2, S/N: D162554351

2.7.3 Date of Test and Modification State

28 February, 01 and 25 March 2013 – Modification State 0

2.7.4 Test Equipment Used

The major items of test equipment used for the above tests are identified in Section 3.1.

2.7.5 Test Method and Operating Modes

The test was applied in accordance with the test method requirements of FCC CFR 47 Part 2 and Part 24 and Industry Canada RSS-133.

In accordance with Part 2.1051, the spurious emissions from the antenna terminal were measured. The transmitter output power was attenuated using an attenuator and the frequency spectrum investigated from 9kHz to 25GHz. The EUT was set to transmit on maximum power. The resolution was set to 1MHz for 9kHz to 25GHz thus meeting the requirements of Part 24.238 (b). The spectrum analyser detector was set to peak and trace was kept on Max Hold.

The maximum path loss across the measurement band was used as the reference level offset to ensure worst case.

In addition, measurements were made up to the 10th harmonics of the highest internal frequency.

The test was performed with the EUT in the following configurations and modes of operation:

Configuration 1 - Mode 1
 - Mode 2
 - Mode 3
 - Mode 7
 - Mode 8
 - Mode 9
 - Mode 10
 - Mode 11
 - Mode 12



Product Service

2.7.6 Environmental Conditions

	28 February 2013	01 March 2013	25 March 2013
Ambient Temperature	22.0°C	22.0°C	20.8°C
Relative Humidity	26.5%	46.5%	23.5%

2.7.7 Test Results

For the period of test the EUT met the requirements of FCC CFR 47 Part 2 and Part 24 and Industry Canada RSS-133 for Conducted Spurious Emissions.

The test results are shown below

Remark:

The emissions at 9kHz on the plots was not generated by the test object. A complementary measurement with a smaller Span showed that it was related to the LO feedthrough.

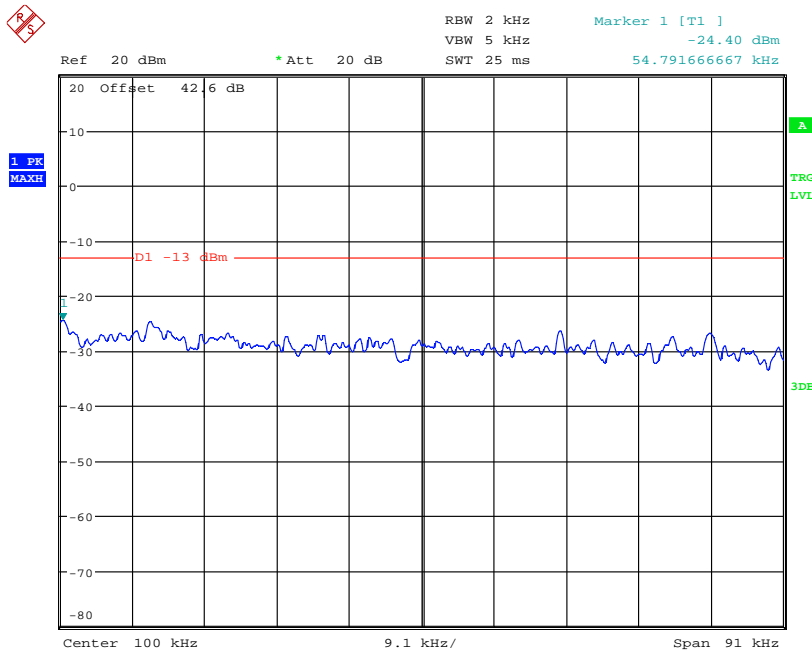

Date: 28.FEB.2013 00:52:39



Product Service

Single Carrier

GMSK

Configuration 1 - Mode 1

9kHz to 3GHz

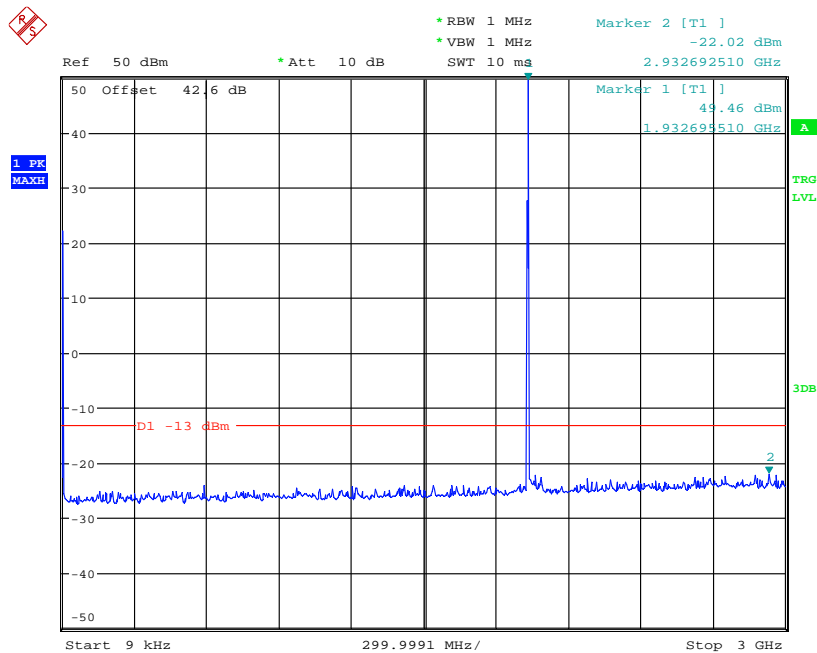

Date: 28.FEB.2013 00:56:54

Note: The emission beyond the limit is the operating frequency.



3GHz to 25GHz

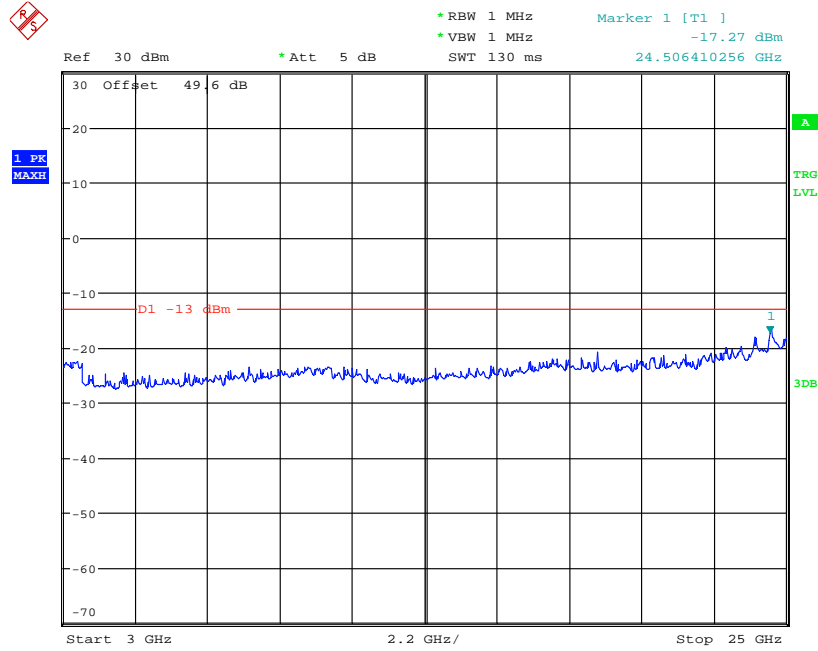

Date: 28.FEB.2013 00:55:38

Configuration 1 - Mode 2

9kHz to 3GHz

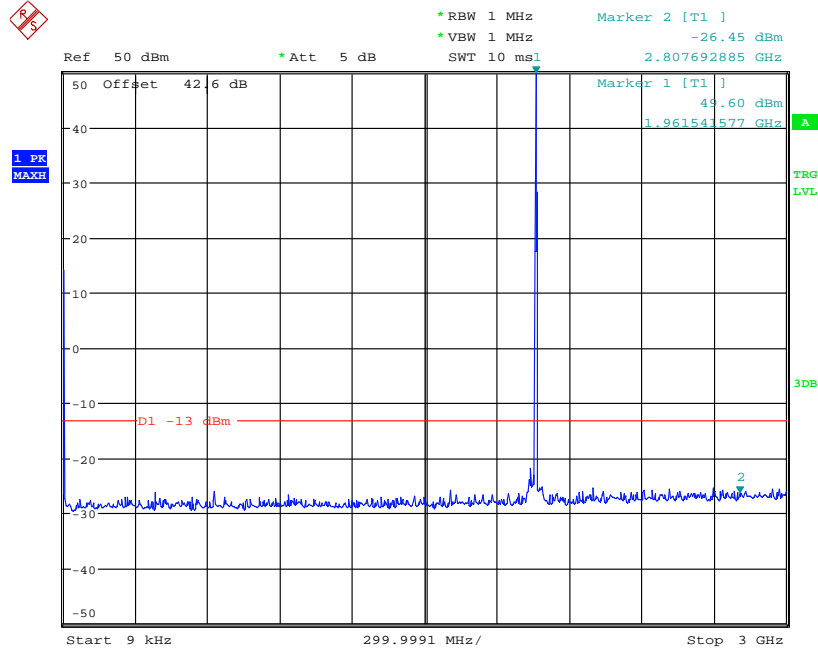

Date: 28.FEB.2013 00:45:18

Note: The emission beyond the limit is the operating frequency.



3GHz to 25GHz

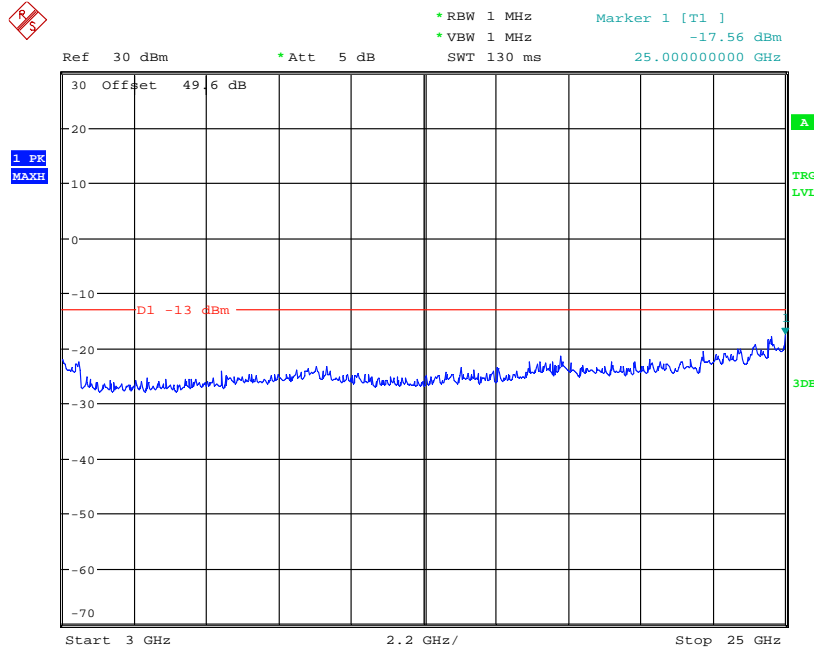

Date: 28.FEB.2013 01:01:04

Configuration 1 – Mode 3

9kHz – 3GHz

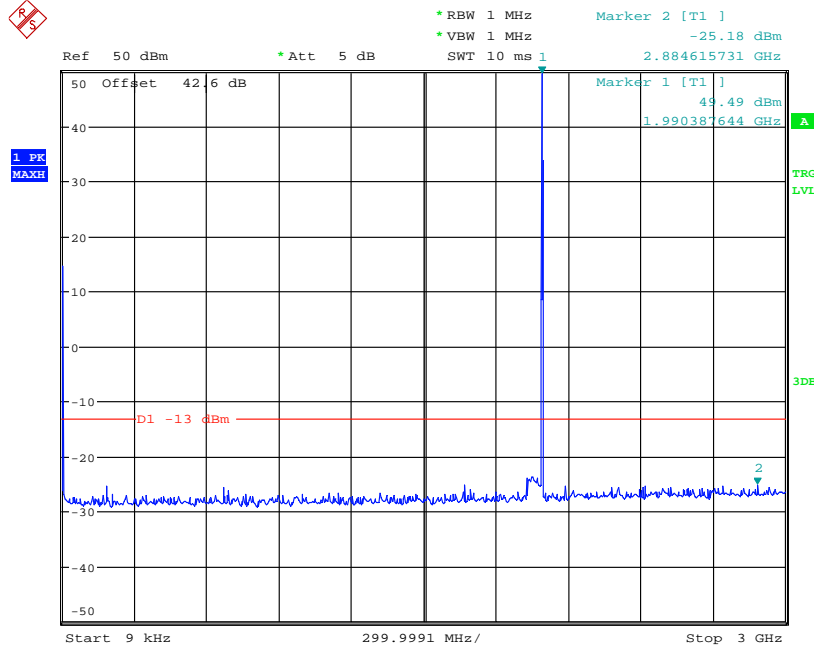

Date: 28.FEB.2013 00:59:13

Note: The emission beyond the limit is the operating frequency.



3GHz – 25GHz

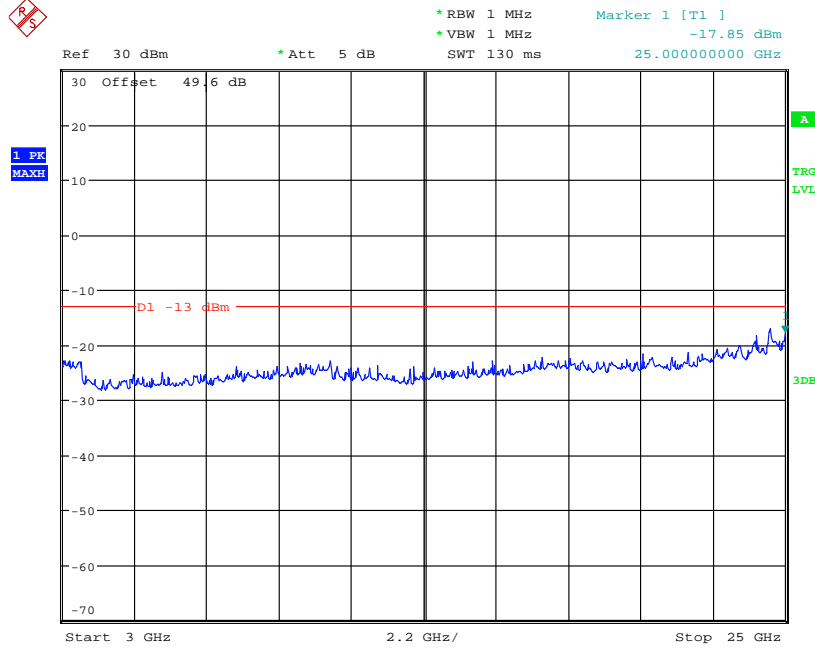

Date: 28.FEB.2013 01:00:14

8-PSK

Configuration 1 - Mode 1

9kHz to 3GHz

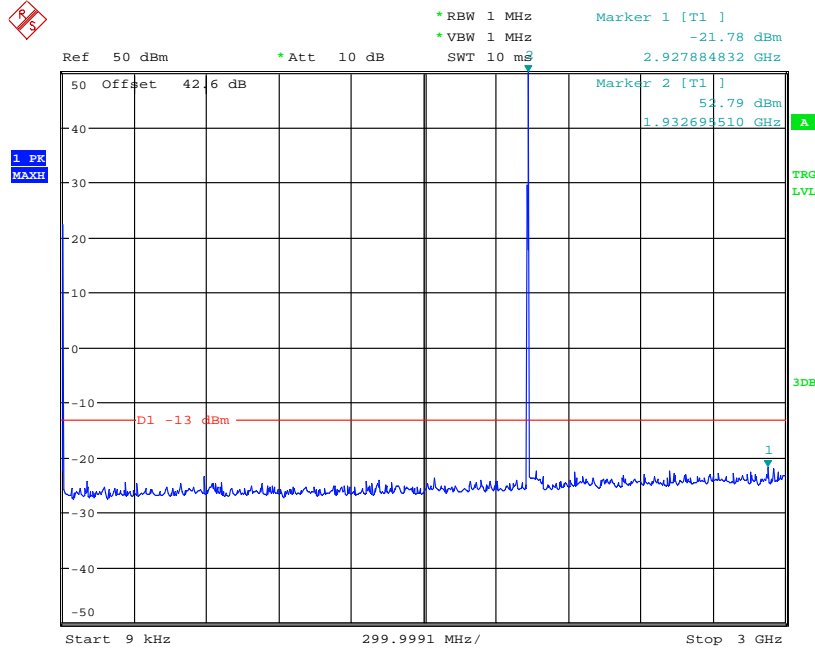

Date: 28.FEB.2013 00:50:20

Note: The emission beyond the limit is the operating frequency.



3GHz to 25GHz

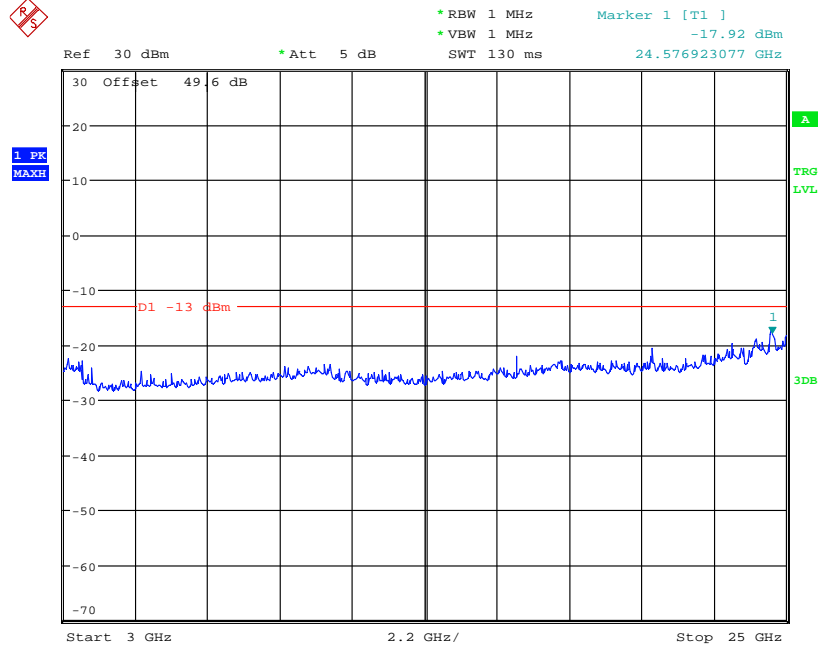

Date: 28.FEB.2013 00:53:42

Configuration 1 - Mode 2

9kHz to 3GHz

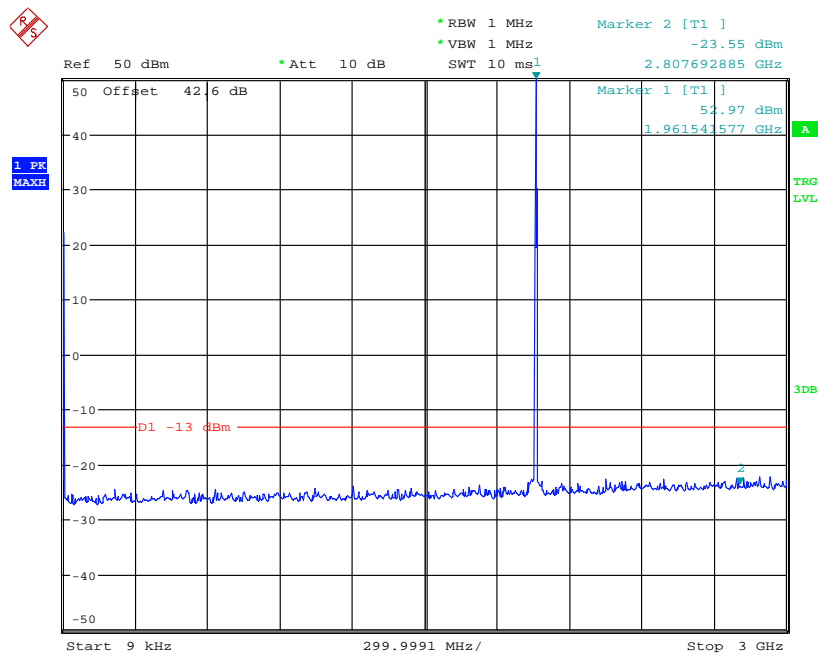

Date: 28.FEB.2013 00:47:51

Note: The emission beyond the limit is the operating frequency.



3GHz to 25GHz

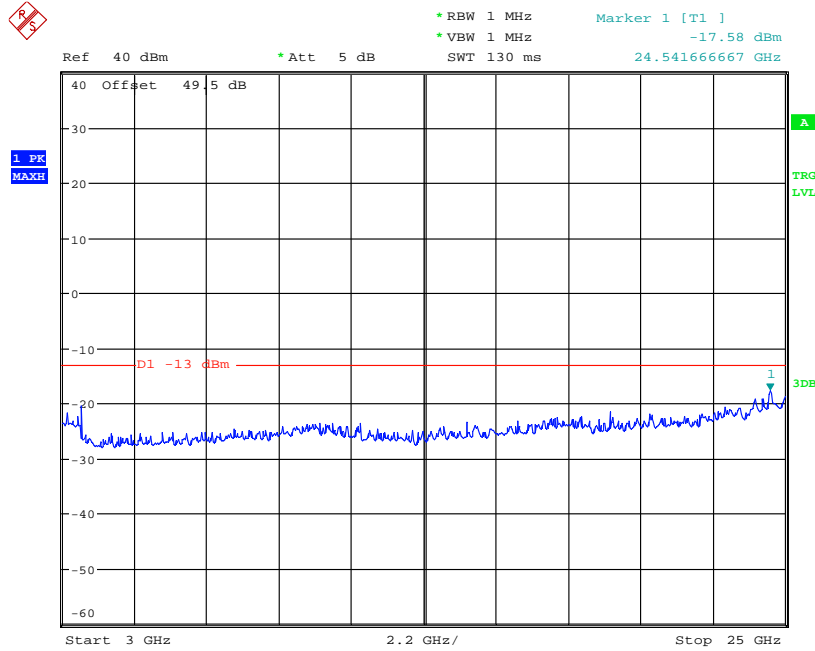

Date: 28.FEB.2013 00:23:07

Configuration 1 – Mode 3

9kHz – 3GHz

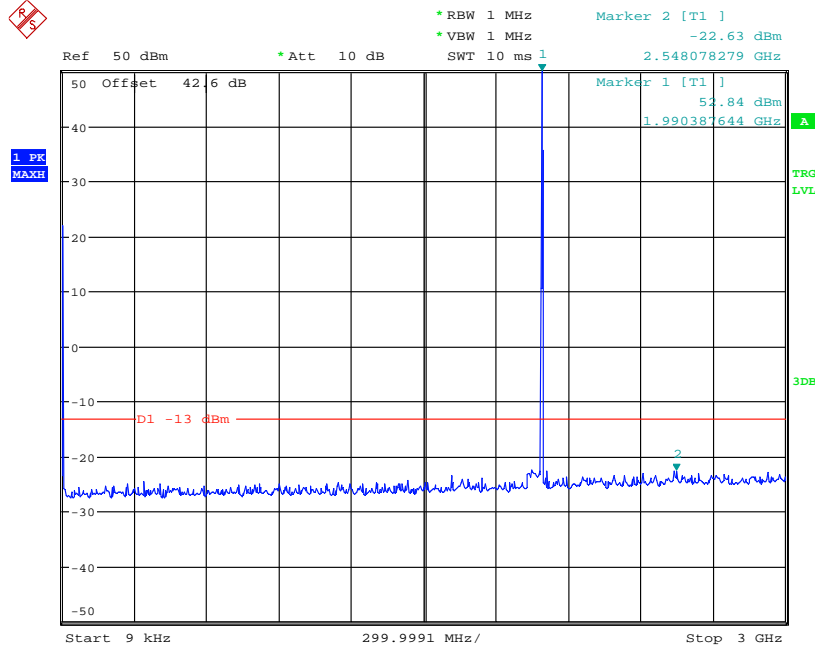

Date: 28.FEB.2013 01:04:21

Note: The emission beyond the limit is the operating frequency.



3GHz – 25GHz

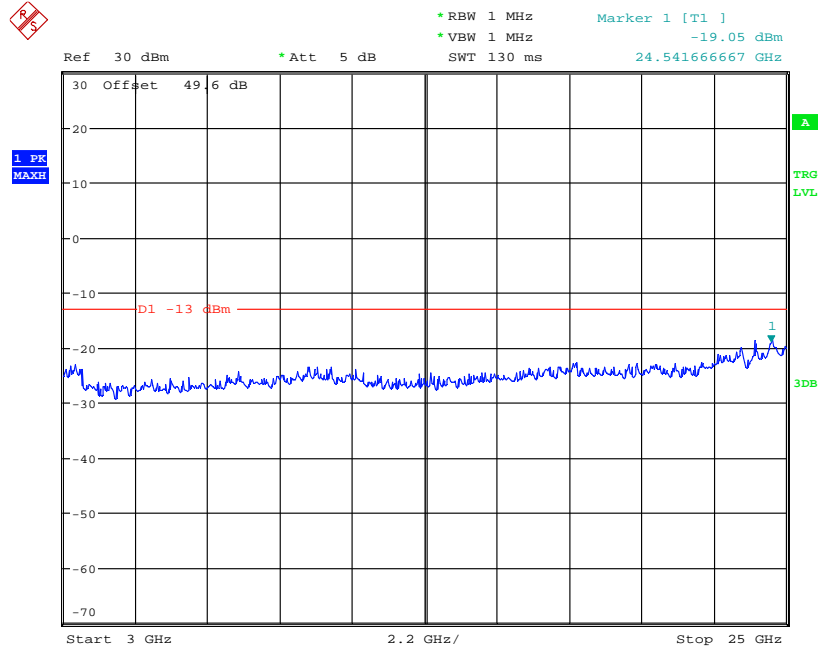

Date: 28.FEB.2013 01:03:22



Multi Carrier (1x3)

GMSK

Configuration 1 - Mode 7

9kHz to 1GHz

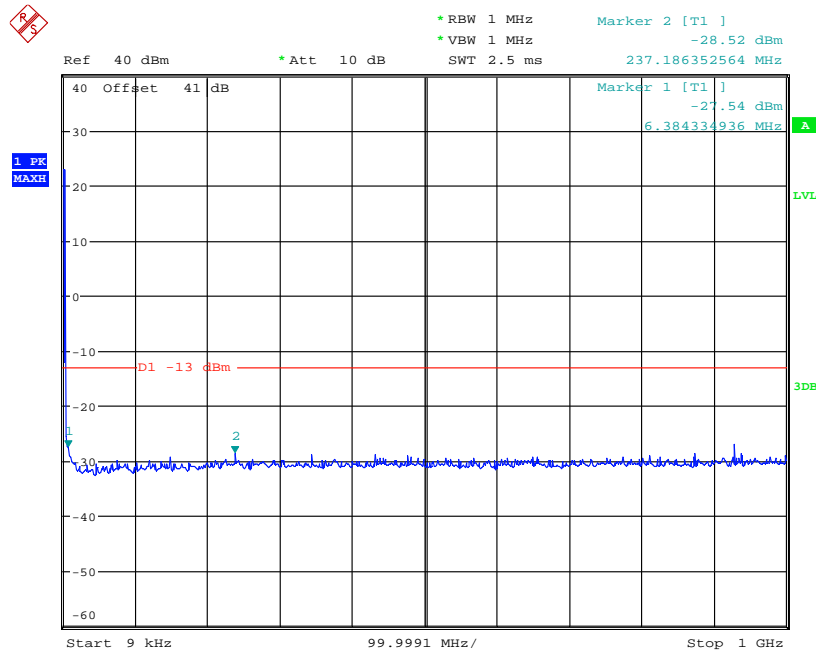

Date: 25.MAR.2013 03:44:43



1GHz to 3GHz

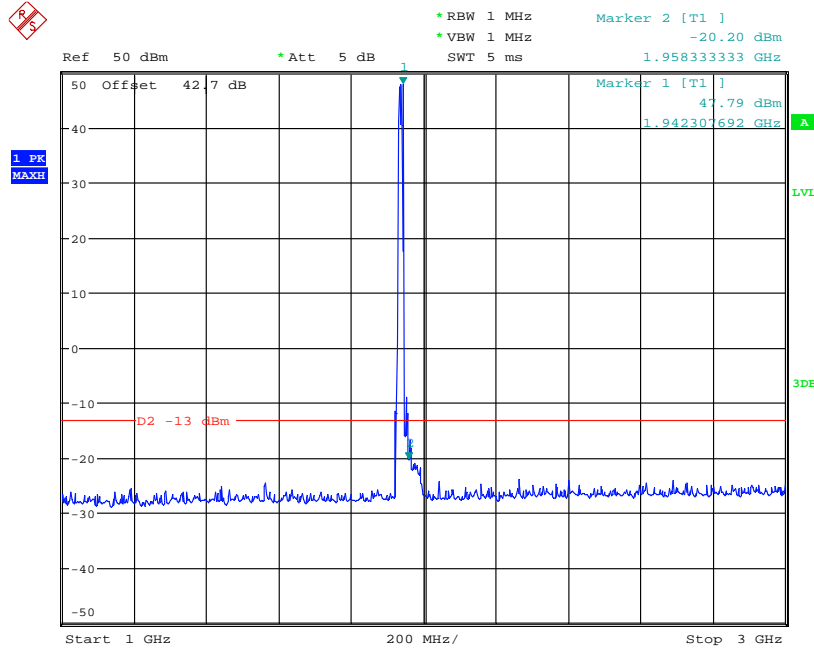

Date: 25.MAR.2013 04:59:34

Note: The emissions beyond the limit are the operating frequencies.

3GHz to 25GHz

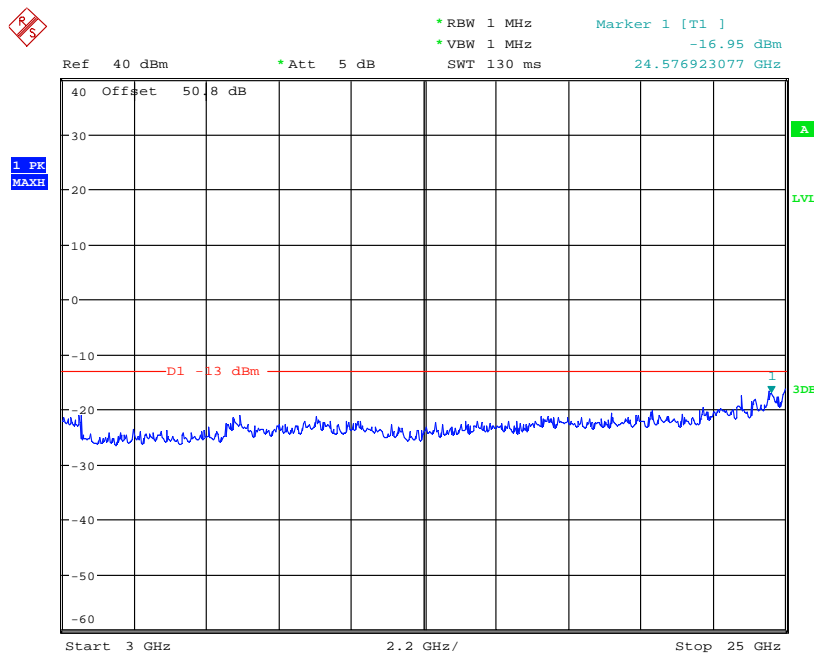

Date: 25.MAR.2013 05:00:29



Configuration 1 - Mode 8

9kHz to 1GHz

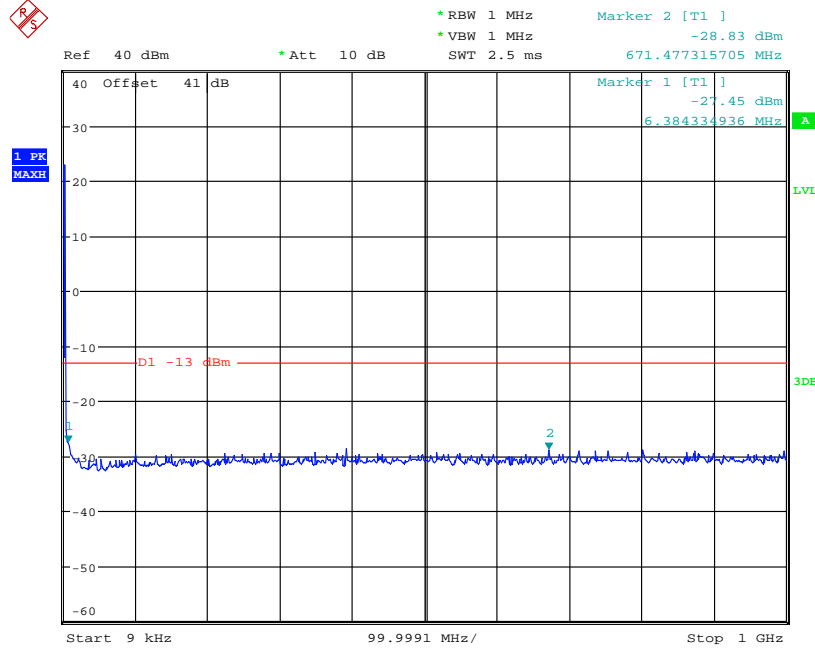

Date: 25.MAR.2013 03:41:56

1GHz to 3GHz

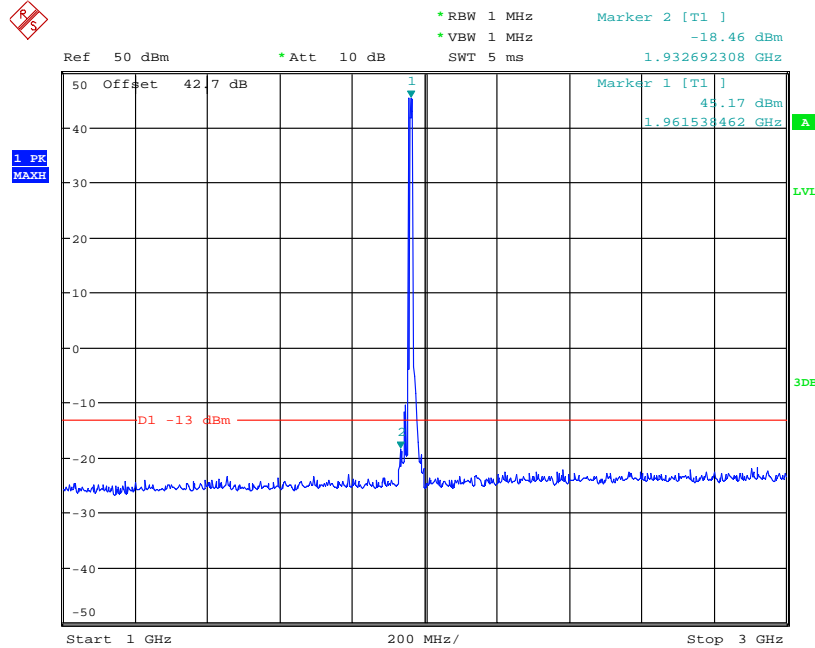

Date: 25.MAR.2013 04:31:14

Note: The emissions beyond the limit are the operating frequencies.



3GHz to 25GHz

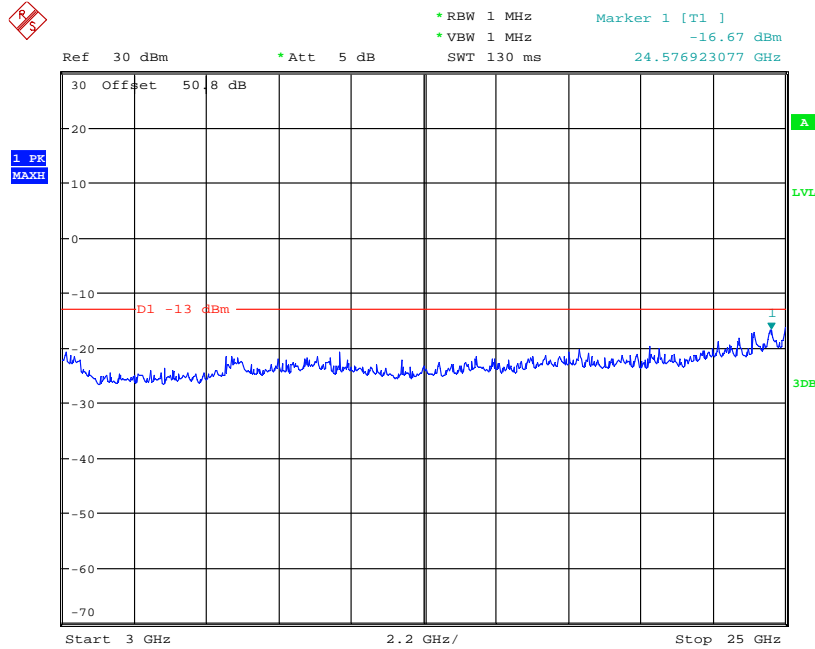

Date: 25.MAR.2013 04:42:23

Configuration 1 – Mode 9

9kHz to 1GHz

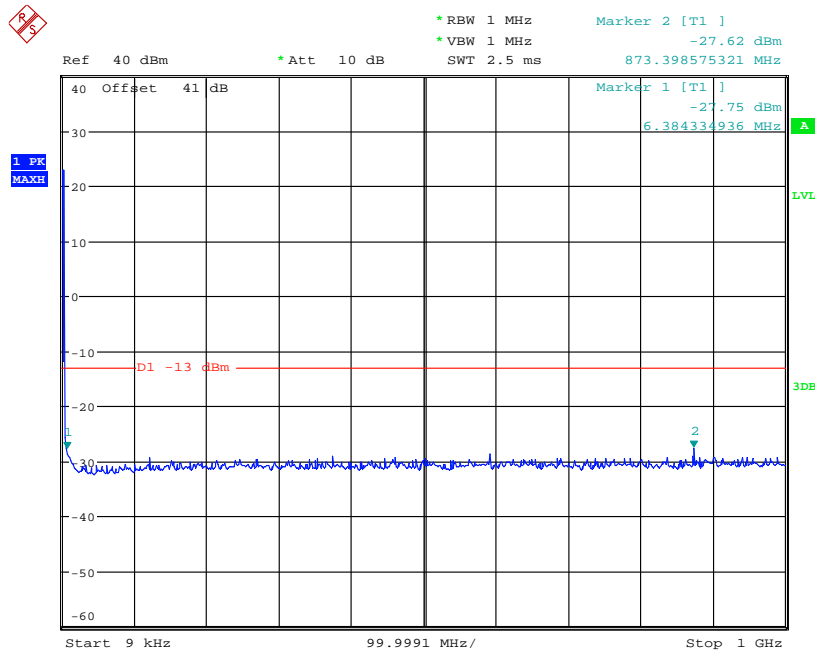

Date: 25.MAR.2013 03:49:24



1GHz to 3GHz

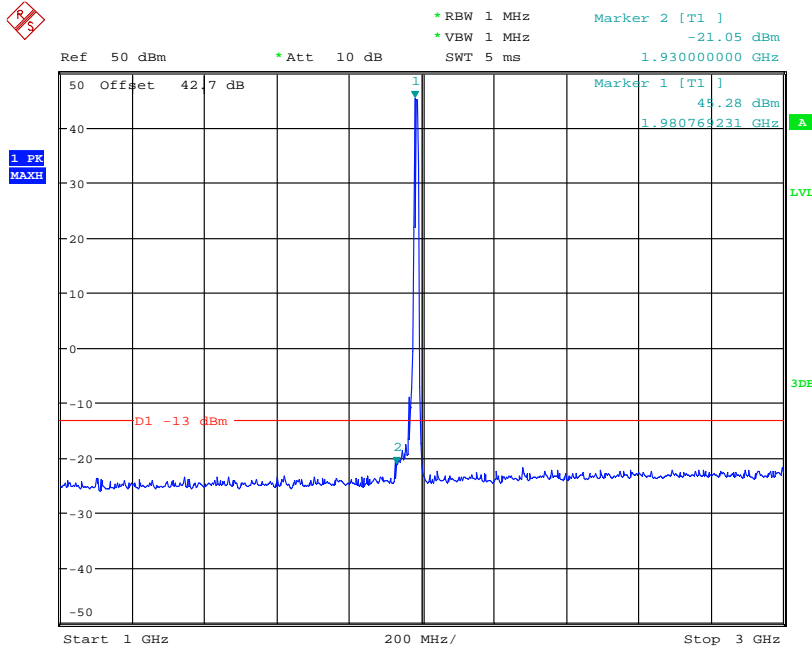

Date: 25.MAR.2013 04:17:00

Note: The emissions beyond the limit are the operating frequencies.

3GHz to 25GHz

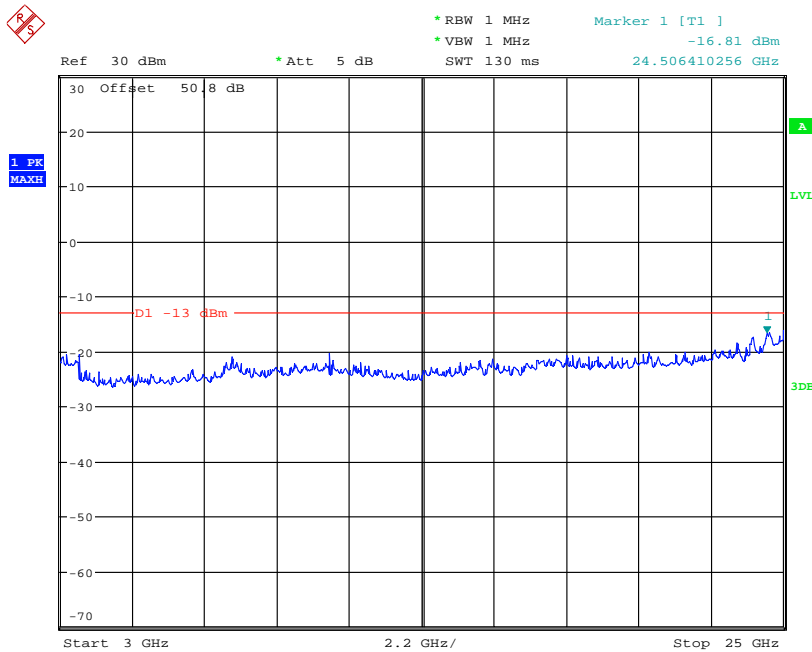

Date: 25.MAR.2013 04:42:47



8-PSK

Configuration 1 - Mode 7

9kHz to 1GHz

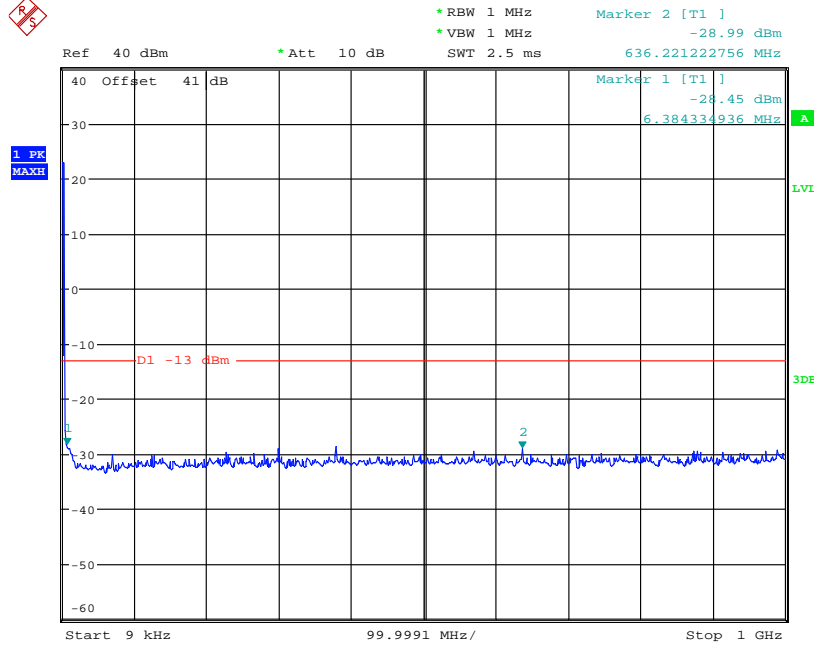

Date: 25.MAR.2013 03:46:20

1GHz to 3GHz

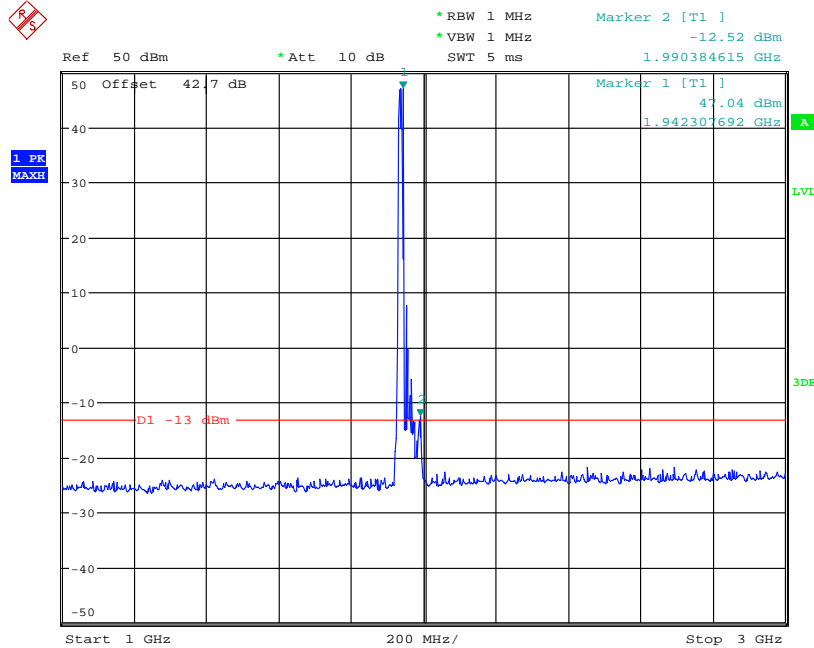

Date: 25.MAR.2013 04:51:21

Note: The emissions beyond the limit are the operating frequencies.

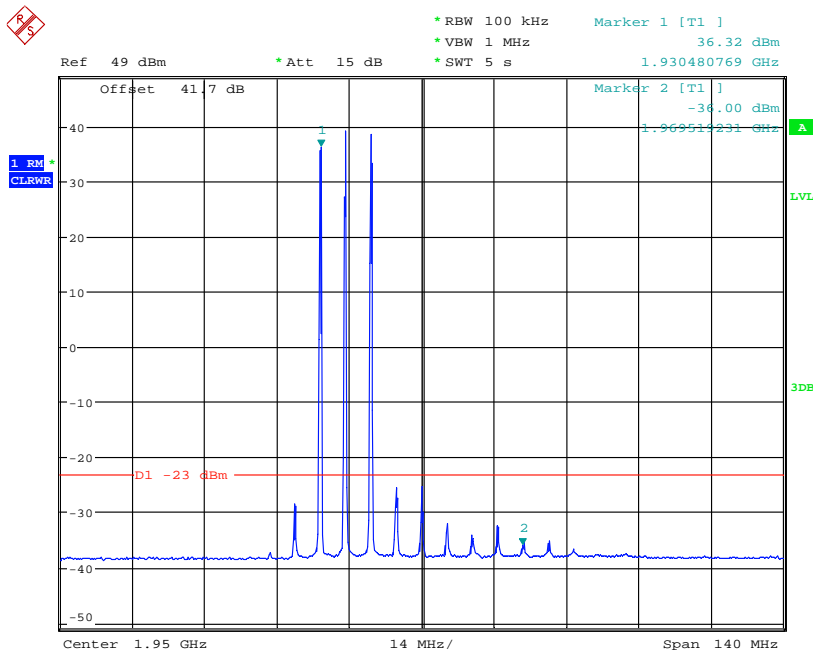

Date: 25.MAR.2013 04:53:51

3GHz to 25GHz

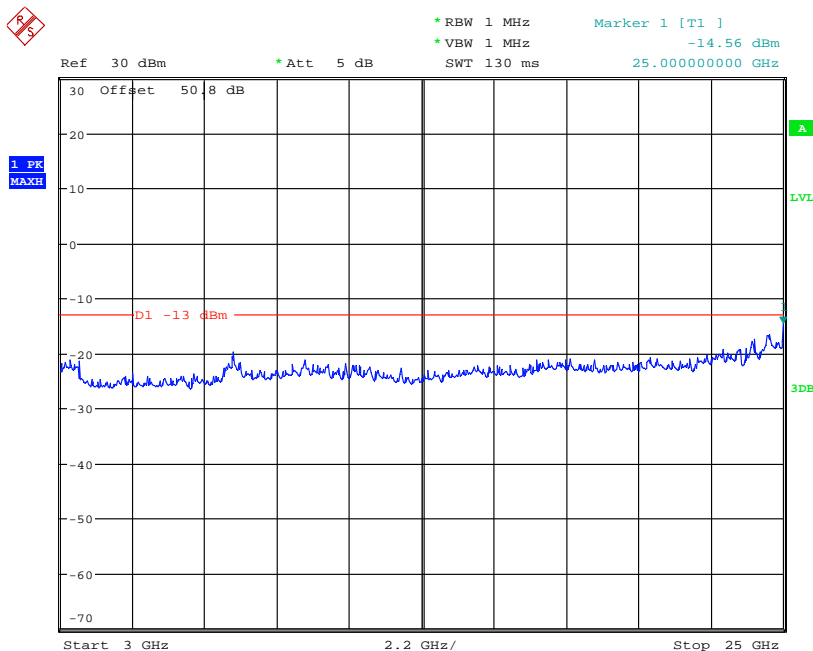

Date: 25.MAR.2013 04:55:39



Configuration 1 - Mode 8

9kHz to 1GHz

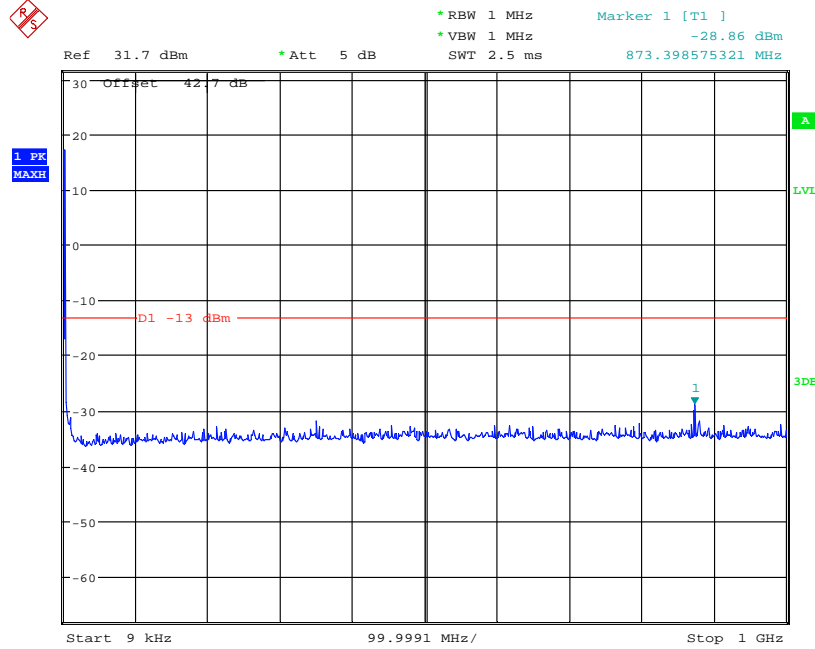

Date: 25.MAR.2013 03:28:56

1GHz to 3GHz

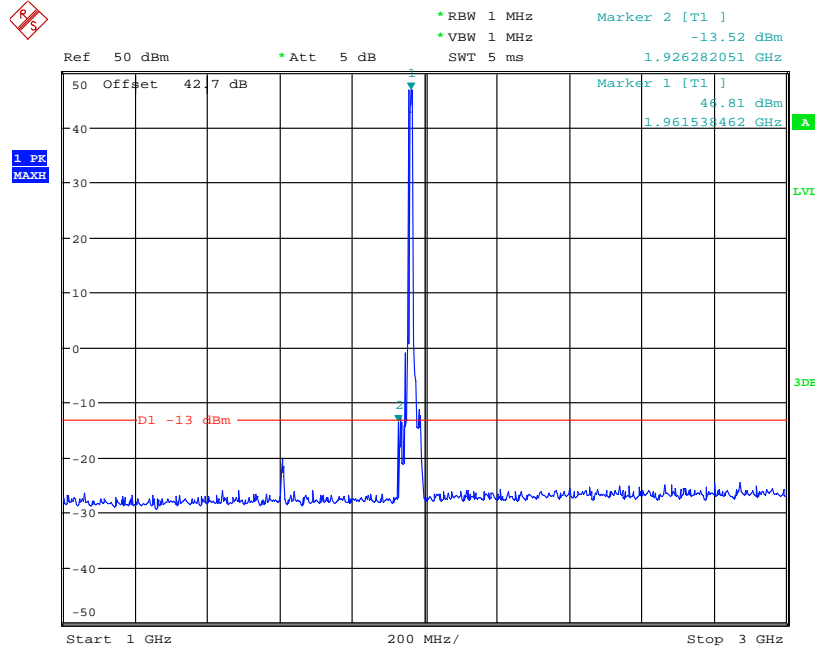

Date: 25.MAR.2013 04:45:26

Note: The emissions beyond the limit are the operating frequencies.



Product Service

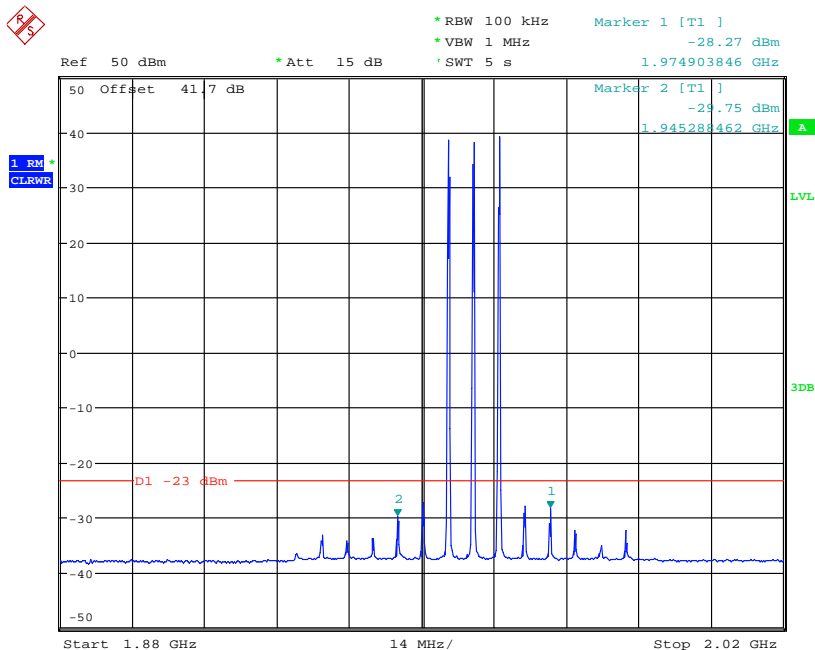

Date: 25.MAR.2013 04:47:47

3GHz to 25GHz

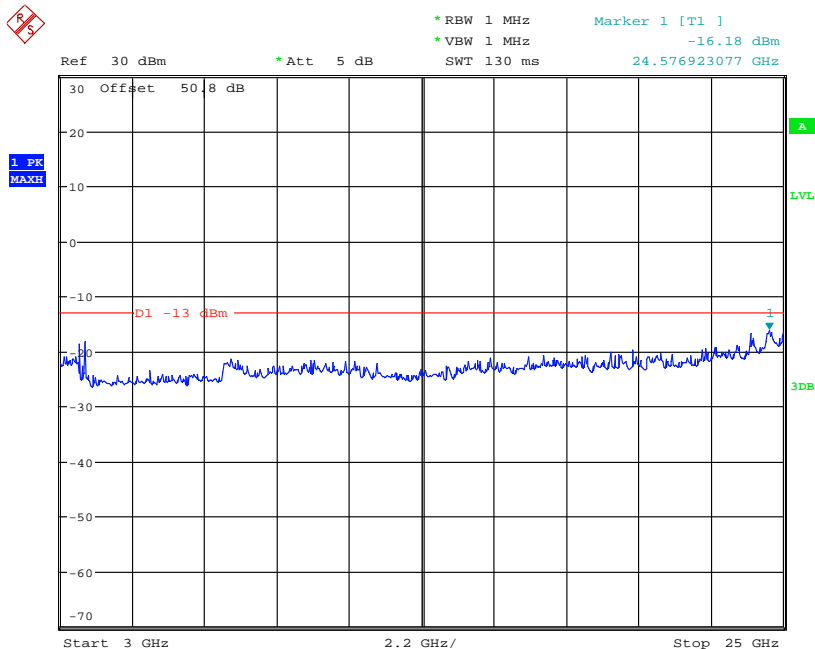

Date: 25.MAR.2013 04:44:24



Configuration 1 – Mode 9

9kHz to 1GHz

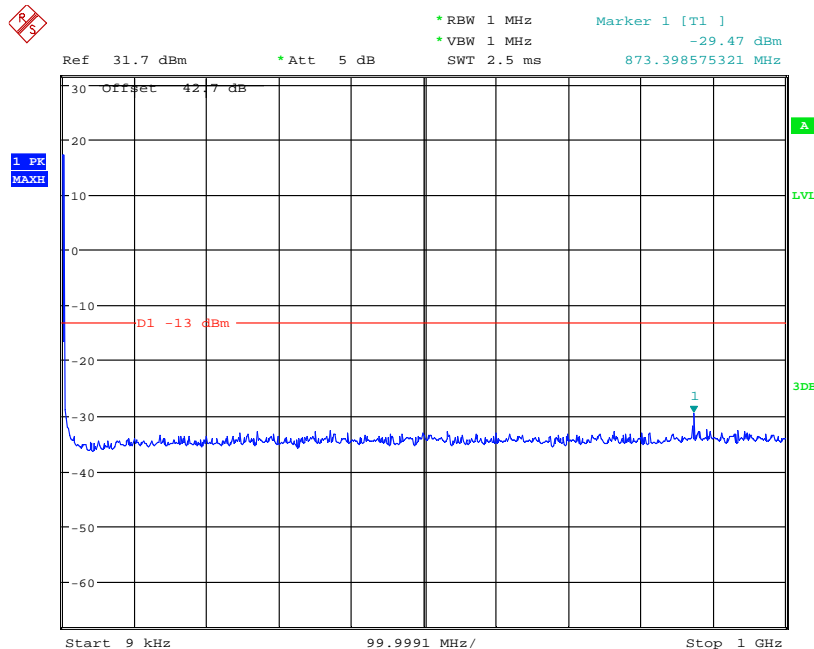

Date: 25.MAR.2013 03:23:31

1GHz to 3GHz

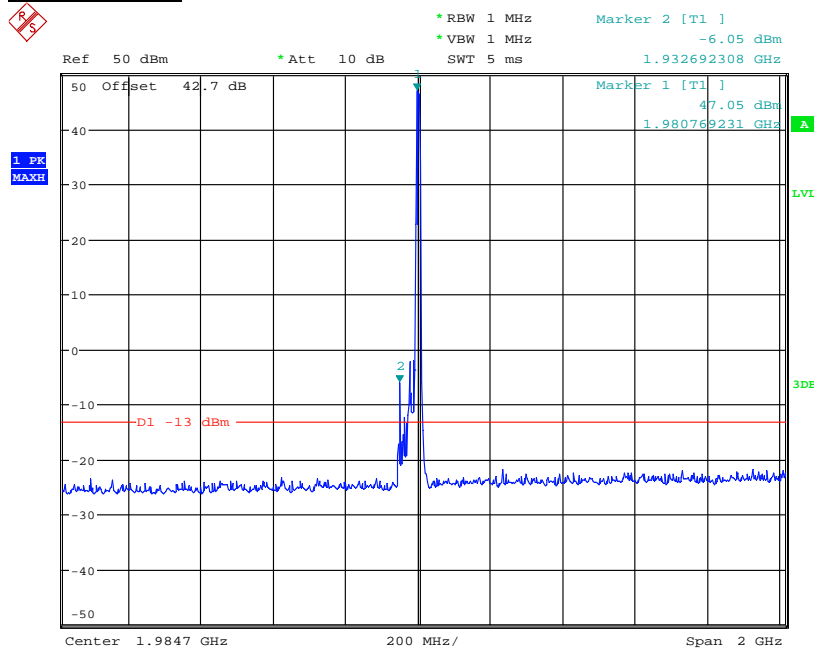

Date: 25.MAR.2013 03:57:51

Note: The emissions beyond the limit are the operating frequencies.

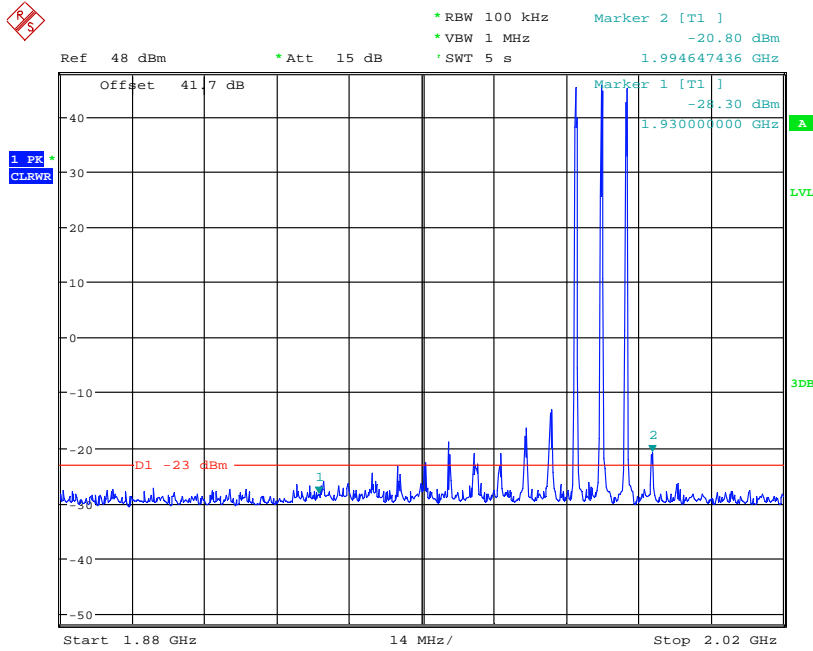

Date: 25.MAR.2013 04:06:50

The Channel Power for 1994.6MHz is -15.21dBm

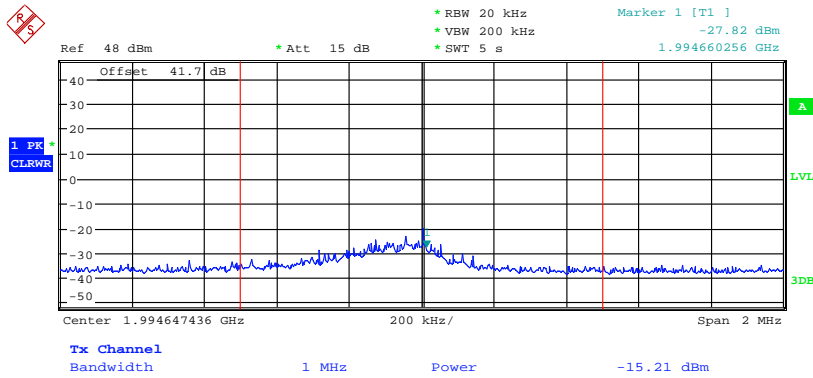

Date: 25.MAR.2013 04:08:59



Product Service

3GHz to 25GHz

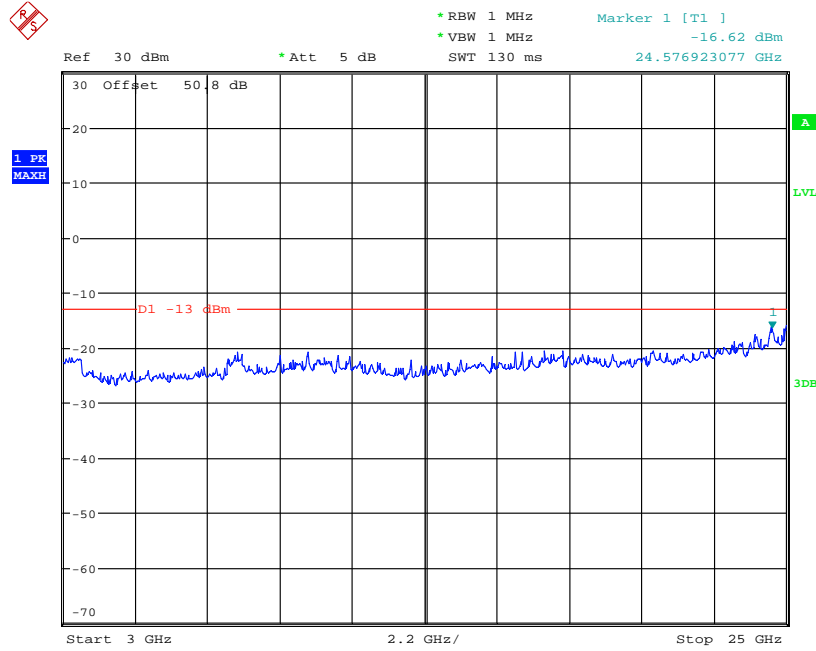

Date: 25.MAR.2013 04:43:03



Product Service

Multi Carrier (1x4)

GMSK

Configuration 1 - Mode 10

9kHz to 3GHz

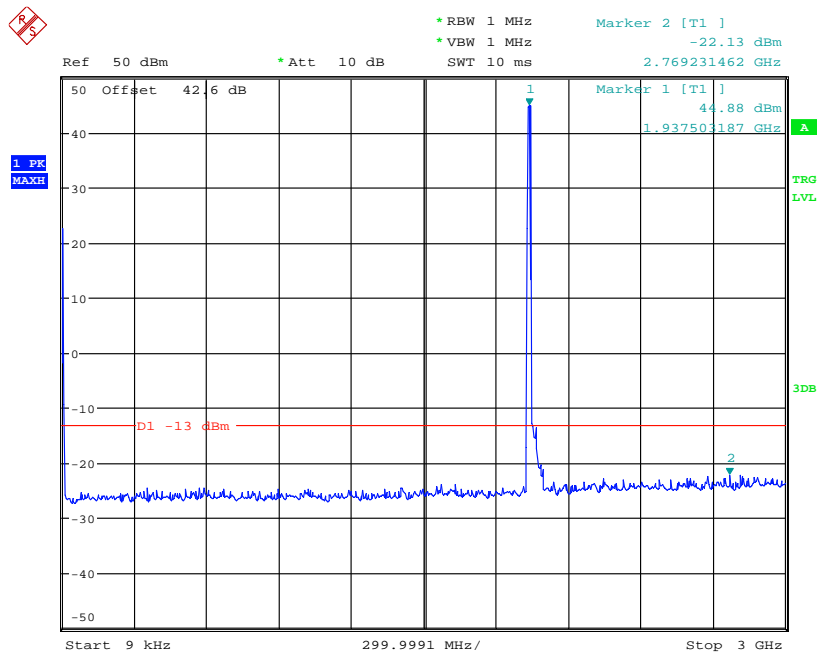

Date: 1.MAR.2013 00:15:50

Note: The emissions beyond the limit are the operating frequencies.



3GHz to 25GHz

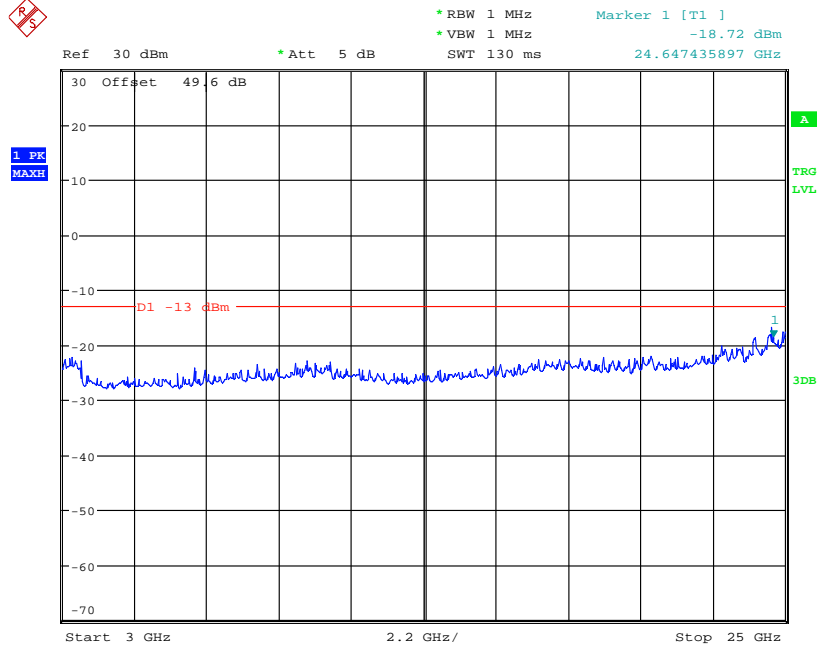

Date: 1.MAR.2013 00:49:05

Configuration 1 - Mode 11

9kHz to 3GHz

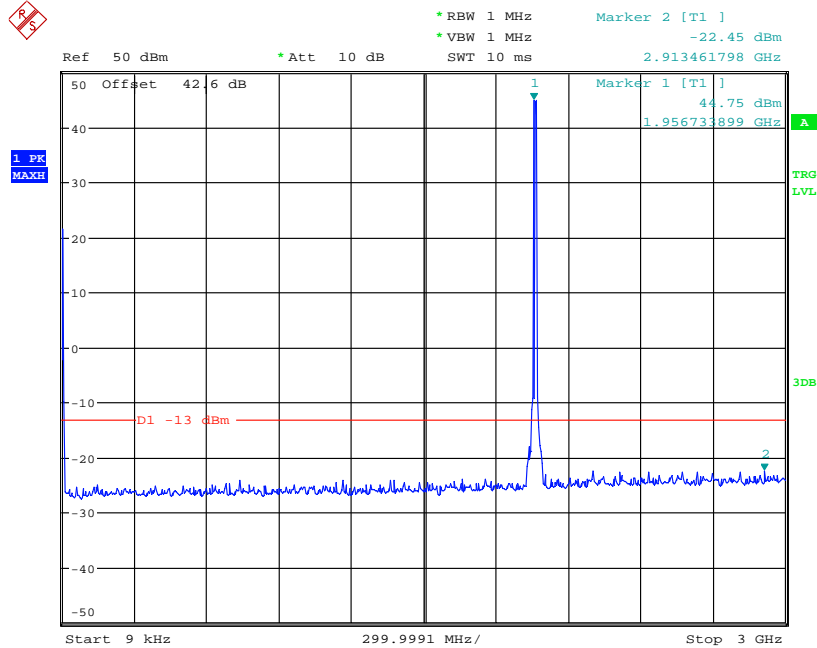

Date: 1.MAR.2013 00:43:44

Note: The emissions beyond the limit are the operating frequencies.



3GHz to 25GHz

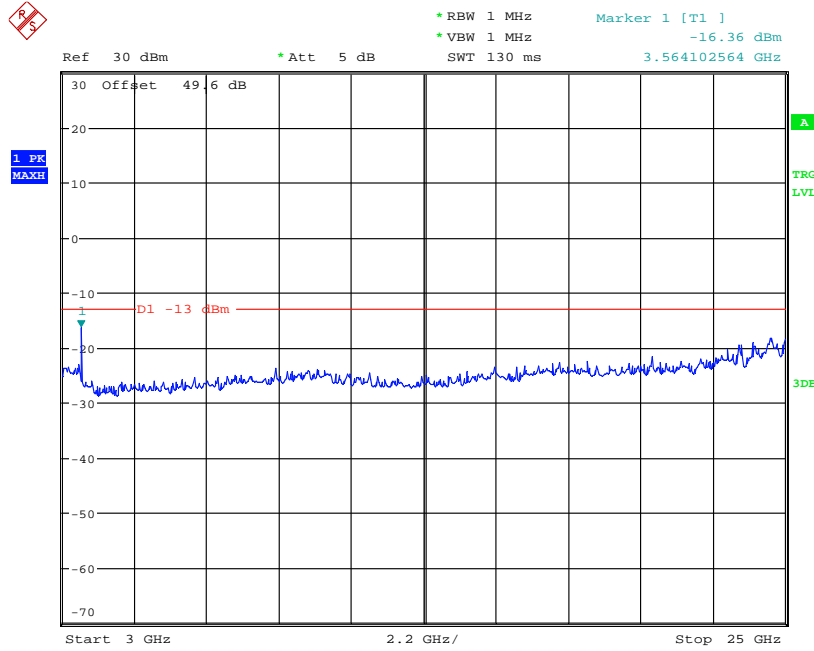

Date: 1.MAR.2013 00:45:00

Configuration 1 – Mode 12

9kHz – 3GHz

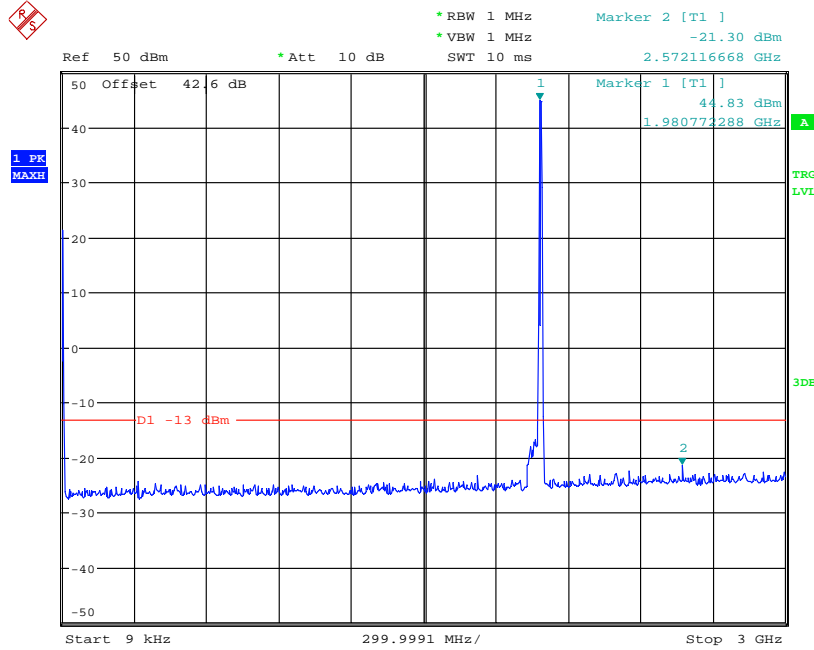

Date: 1.MAR.2013 00:50:59

Note: The emissions beyond the limit are the operating frequencies.



3GHz – 25GHz

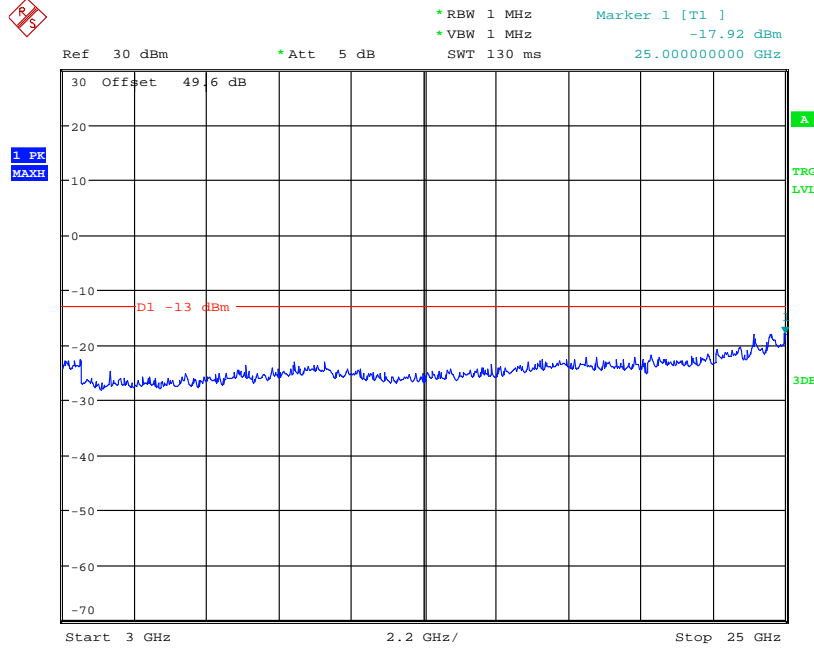

Date: 1.MAR.2013 00:48:34

8-PSK

Configuration 1 - Mode 10

9kHz to 3GHz

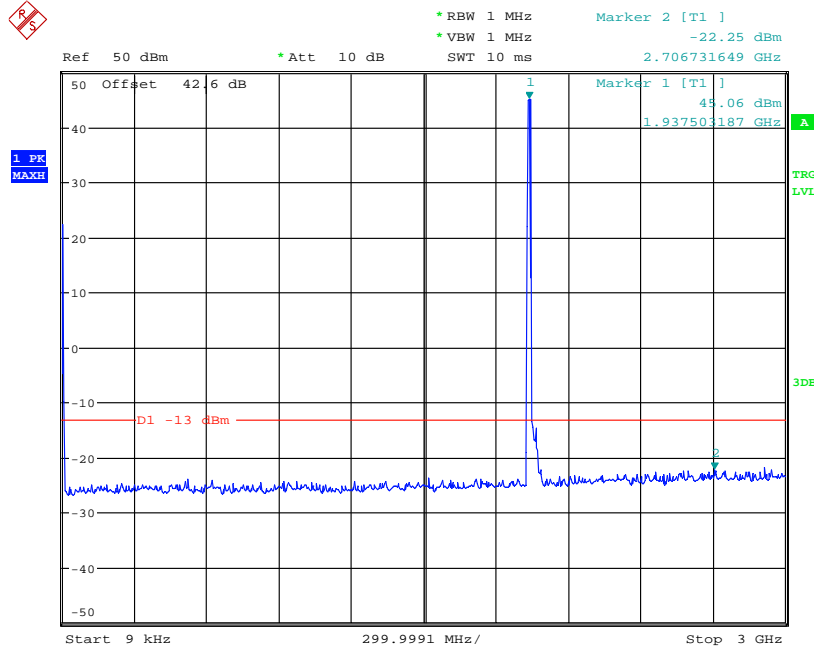

Date: 1.MAR.2013 00:25:15

Note: The emissions beyond the limit are the operating frequencies.



3GHz to 25GHz

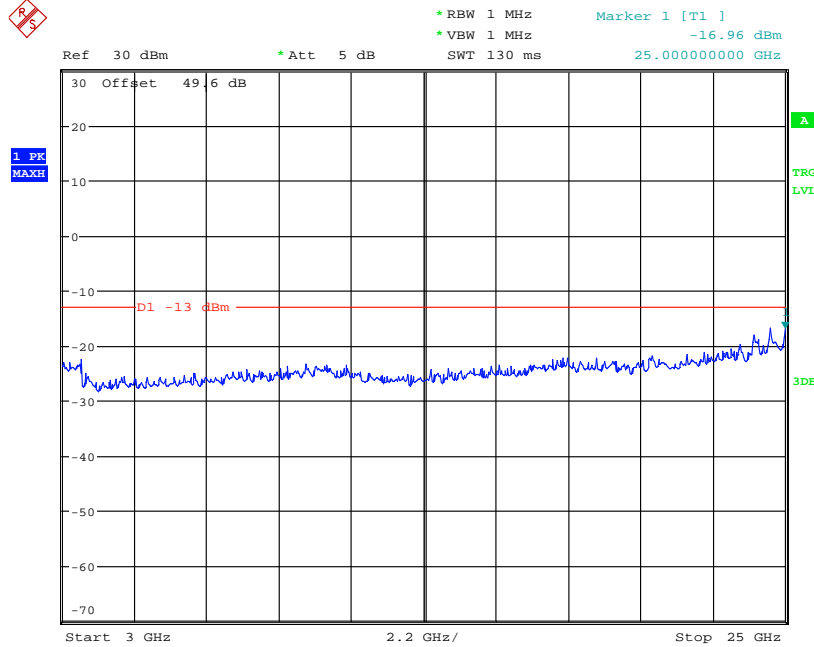

Date: 1.MAR.2013 00:37:58

Configuration 1 - Mode 11

9kHz to 3GHz

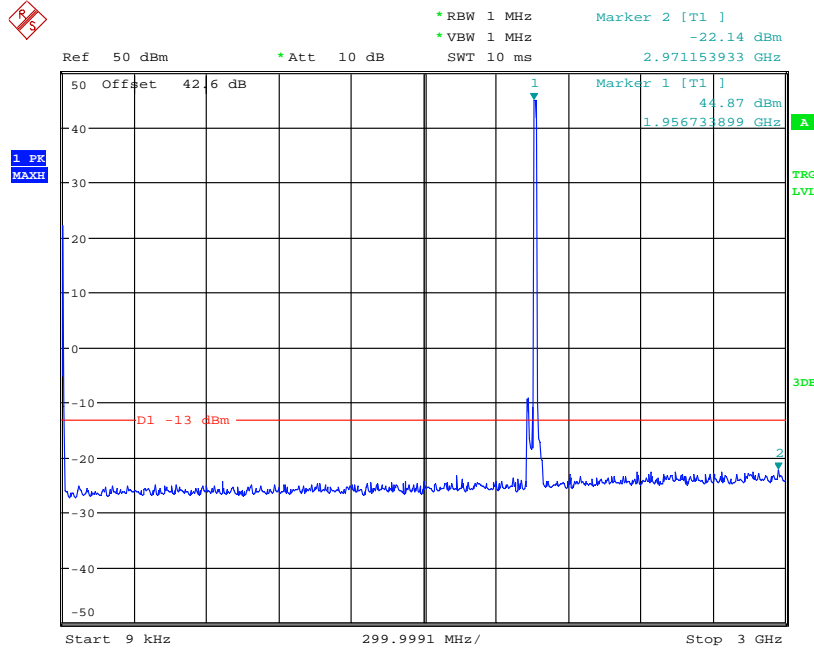

Date: 1.MAR.2013 00:34:51

Note: The emissions around the carriers are within the operating frequency band.



3GHz to 25GHz

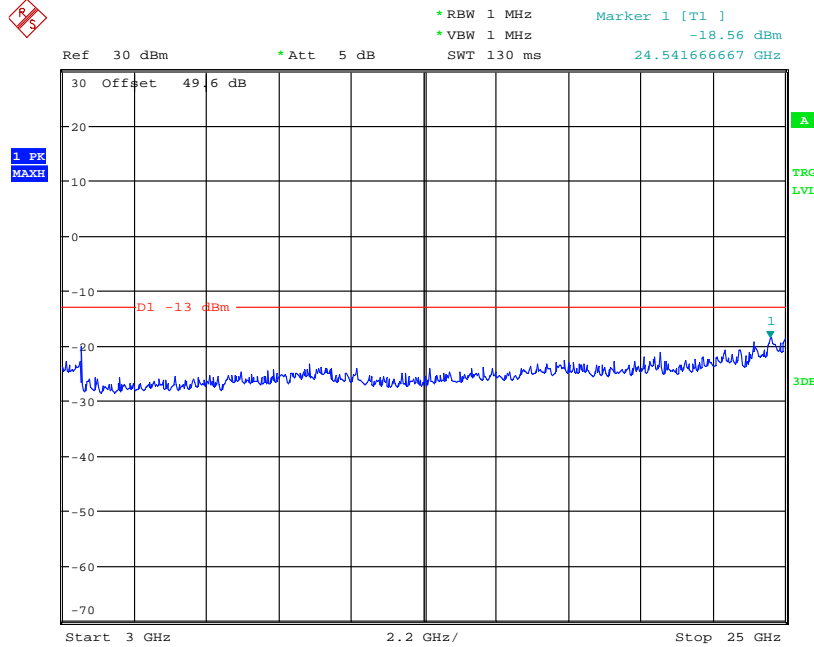

Date: 1.MAR.2013 00:37:31

Configuration 1 – Mode 12

9kHz – 3GHz

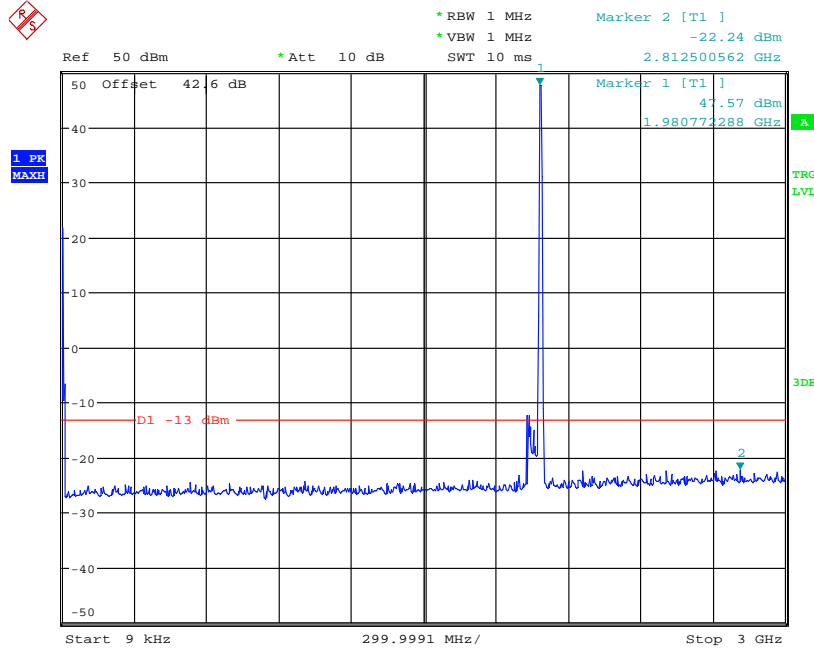

Date: 1.MAR.2013 00:53:57

Note: The emissions around the carriers are within the operating frequency band.



3GHz – 25GHz

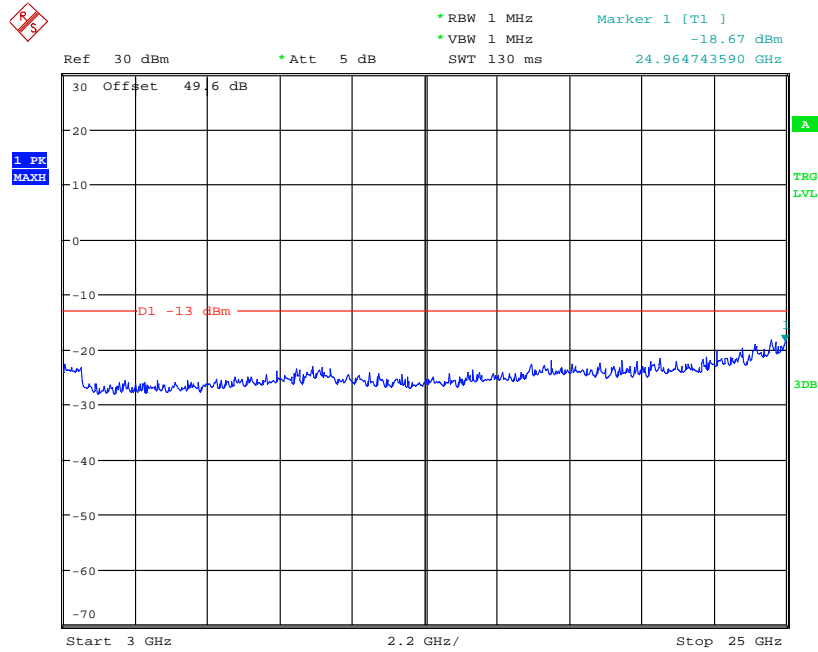

Date: 1.MAR.2013 00:55:33

Limit	-13dBm
-------	--------

Remarks

The EUT does not exceed -13dBm at the frequency range of 9kHz to 25GHz.



Product Service

SECTION 3

TEST EQUIPMENT USED



3.1 TEST EQUIPMENT USED

List of absolute measuring and other principal items of test equipment.

Instrument	Manufacturer	Type No.	Serial No.	Calibration Period (months)	Calibration Due
Section 2.1, 2.2, 2.3, 2.4, 2.5, 2.7 – Maximum Conducted Output Power, Peak – Average Ratio, Modulation Characteristics, Occupied Bandwidth, Spurious Emissions at Antenna Terminals (± 1MHz) and Conducted Spurious Emissions.					
Spectrum Analyser	Rohde & Schwarz	FSQ26	200014	12	06-Sep-2013
Spectrum Analyser	Rohde & Schwarz	FSQ26	201123	12	09-Apr-2013
Power Meter	Rohde & Schwarz	NRP	101283	12	12-Aug-2013
Power Sensor	Rohde & Schwarz	NRP-Z21	102106	12	12-Aug-2013
Network Analyzer	Agilent	8720D	US38431317	12	24-Aug-2013
40dB Attenuator	Aeroflex / Weinschel	48-40-43-LIM	BR5020	-	O/P MON
Load	Nanjing Jiexi	TF100	09121602	-	O/P MON
Power Supply	Dahua	DH1716A-14	20080406	-	O/P MON
Digital Multi-meter	FLUKE	179	91820401	12	13-Dec-2013
Thermo-hygrometer	AZ Instruments	8705	9151655	12	16-Dec-2013
Section 2.6 – Radiated Spurious Emissions					
Load	Shanghai Huaxiang	TFZ50C-3FR	JW8042-04A-021	-	O/P MON
Load	Shanghai Huaxiang	TF100	09121602	-	O/P MON
EMI Receiver	Rohde & Schwarz	ESI 40	100015	12	19-Aug-2013
Ultra log test antenna	Rohde & Schwarz	HL562	100167	12	19-Aug-2013
Double-Ridged Waveguide Horn Antenna	Rohde & Schwarz	HF 906	100029	12	19-Aug-2013
Pyramidal Horn Antenna	EMCO	3160-09	-	-	-
Antenna master	Frankonia	MA 260	-	12	19-Aug-2013
Relay Switch Unit	Rohde & Schwarz	331.1601.31	338965002	-	TU
Semi Anechoic Chamber	Frankonia	23.18m×16.88m×9.60m	-	12	19-Aug-2013
Power Supply	Dahua	DH1716A-14	20080406	-	O/P MON
Power Supply	Dahua	DH1716A-14	20080403	-	O/P MON
Digital Multimeter	FLUKE	179	91820401	12	13-Dec-2013
Thermo-hygrometer	AZ Instruments	8705	9151655	12	16-Dec-2013

O/P MON Output monitored with calibration equipment
 TU Traceability Unscheduled



Product Service

3.2 MEASUREMENT UNCERTAINTY

For a 95% confidence level, the measurement uncertainties for defined systems are:-

Test Discipline	Frequency / Parameter	MU
Conducted Maximum Peak Output Power	30MHz to 10GHz Amplitude	0.5dB*
Conducted Emissions	30MHz to 40GHz Amplitude	3.0dB*
Frequency Stability	30MHz to 2GHz Amplitude	$<1 \times 10^{-7}$
Radiated Emissions, Bilog Antenna, AOATS	30MHz to 1GHz Amplitude	5.1dB*
Radiated Emissions, Horn Antenna, AOATS	1GHz to 40GHz Amplitude	6.3dB*
Worst case error for both Time and Frequency measurement 12 parts in 10^6		

* In accordance with CISPR 16-4



Product Service

SECTION 4

ACCREDITATION, DISCLAIMERS AND COPYRIGHT



Product Service

4.1 ACCREDITATION, DISCLAIMERS AND COPYRIGHT



This report relates only to the actual item/items tested.

Our UKAS Accreditation does not cover opinions and interpretations and any expressed are outside the scope of our UKAS Accreditation.

Results of tests not covered by our UKAS Accreditation Schedule are marked NUA (Not UKAS Accredited).

This report must not be reproduced, except in its entirety, without the written permission of TÜV SÜD Product Service

© 2013 TÜV SÜD Product Service