



Product Service

Choose certainty.
Add value.



Report On

FCC and IC Testing of the
Ericsson LTE KRC 118 66/1, KRC 118 66/2 RUS 01 B2 (1900 MHz)
Base Station in accordance with FCC CFR 47 Part 2, FCC CFR 47 Part
24, Industry Canada RSS-GEN and Industry Canada RSS-139

COMMERCIAL-IN-CONFIDENCE

FCC ID: TA8AKRC11866-1 and TA8AKRC11866-2
IC ID: 278AB-AS118661 and 278AB-AS118662

PREPARED BY

Maggie Whiting
Key Account Manager

APPROVED BY

Steve Scarfe
Authorised Signatory

DATED

05 April 2018

Document 75941045 Report 04 Issue 1

April 2018



Product Service

CONTENTS

Section	Page No
1	REPORT INFORMATION 2
1.1	Report Details 3
1.2	Brief Summary of Results 4
1.3	Configuration Description 5
1.4	Declaration of Build Status 6
1.5	Product Information 7
1.6	Test Setup 8
1.7	Test Conditions 9
1.8	Deviation From The Standard 9
1.9	Modification Record 9
1.10	Additional Information 9
2	TEST DETAILS 10
2.1	Maximum Peak Output Power and Peak to Average Ratio - Conducted 11
2.2	Occupied Bandwidth 19
2.3	Band Edge 25
2.4	Transmitter Spurious Emissions 31
2.5	Radiated Spurious Emissions 40
3	TEST EQUIPMENT USED 60
3.1	Test Equipment Used 61
3.2	Measurement Uncertainty 63
4	ACCREDITATION, DISCLAIMERS AND COPYRIGHT 64
4.1	Accreditation, Disclaimers and Copyright 65
ANNEX A	Module Lists A.2



Product Service

SECTION 1

REPORT INFORMATION



Product Service

1.1 REPORT DETAILS

Manufacturer	Ericsson
Address	Torshamnsgatan 23 Kista SE-16480 Stockholm Sweden
Product Name	RUS 01 B2
Product Number	KRC 118 66/2
IC Model Name	AS118662
Serial Number(s)	CF83604455
Software Version	xrus_app-CXP9013268_6-R66AM.xif (based on CXP9013268/6 R66BM)
Hardware Version	R1G
Non- Tested Variant	KRC 118 66/1
Non-Tested Variant IC Model Name	AS118661
Test Specification/Issue/Date	FCC CFR 47 Part 2: 2017 FCC CFR 47 Part 24: 2017 Industry Canada RSS-GEN: Issue 4: 2014 Industry Canada RSS-139: Issue 3: 2015
Start of Test	04 February 2018
Finish of Test	13 February 2018
Name of Engineer(s)	Raj Kumar Kallem Jack Tuckwell
Related Document(s)	KDB 971168 D01 v02r02 KDB 662911 D01 v02r01



Product Service

1.2 BRIEF SUMMARY OF RESULTS

A brief summary of results for each configuration, in accordance with FCC CFR 47 Part 2, FCC CFR 47 Part 24, Industry Canada RSS-GEN and Industry Canada RSS-139 is shown below.

Section	Specification Clause				Test Description	Result
	FCC CFR 47 Part 2	FCC CFR 47 Part 24	RSS-GEN	RSS-139		
2.1	2.1046	24.232(a)	-	6.4	Maximum Peak Output Power and Peak to Average Ratio - Conducted	Pass
2.2	2.1049	24.238	6.6	-	Occupied Bandwidth	Pass
2.3	2.1051	24.238 (b)	-	6.5	Band Edge	Pass
2.4	2.1051	24.238 (a)	-	6.5	Transmitter Spurious Emissions	Pass
2.5	2.1053	24.238(c)	-	6.5	Radiated Spurious Emissions	Pass



Product Service

1.3 CONFIGURATION DESCRIPTION

Configuration	RAT	No. Of carriers	Carrier Bandwidth	Carrier Frequency Configuration (MHz)		
				Bottom	Middle	Top
A	LTE+NB IoT GB	1	10 MHz	1935.0	-	1985.0
A	LTE+NB IoT GB	1	15 MHz	1937.5	-	1982.5
A	LTE+NB IoT GB	1	20 MHz	1940.0	-	1980.0
B	NB IoT SA	1	0.18 MHz	1960.0	1930.2	1989.8



Product Service

1.4 DECLARATION OF BUILD STATUS

MAIN EUT		
MANUFACTURING DESCRIPTION	Radio Unit	
MANUFACTURER	Ericsson AB	
PRODUCT NAME	RUS 01 B2	
PART NUMBER	KRC 118 66/1	KRC 118 66/2
IC Model Name	AS118661 BS118661 CS118661	AS118662
SERIAL NUMBER	-	CF83604455
HARDWARE VERSION	-	R1G
SOFTWARE VERSION	xrus_app-CXP9013268_6-R66AM.xlf (based on CXP9013268/6 R66BM)	
TRANSMITTER OPERATING RANGE	1930 to 1990 MHz	
MODULATIONS	LTE: QPSK, 16QAM, 64QAM, 256QAM	LTE: QPSK, 16QAM, 64QAM, 256QAM
	WCDMA: QPSK, 16QAM, 64QAM	WCDMA: QPSK, 16QAM, 64QAM
	GSM: GMSK, 8-PSK, AQPSK, 16QAM, 32QAM	CDMA: 8-PSK, QPSK, 16QAM
		GSM: GMSK, 8-PSK, AQPSK, 16QAM, 32QAM
INTERMEDIATE FREQUENCIES	-	
ITU DESIGNATION OF EMISSION	GSM: 245KGXW	GSM: 245KGXW
	WCDMA: 3M90F9W, 4M20F9W	CDMA: 1M25F9W
	1,4 MHz BW channel: 1M10F9W	WCDMA: 3M90F9W, 4M20F9W
	3 MHz BW channel: 2M70F9W	1,4 MHz BW channel: 1M10F9W
	5 MHz BW channel: 4M50F9W	3 MHz BW channel: 2M70F9W
	10 MHz BW channel ¹ : 9M40F9W	5 MHz BW channel: 4M50F9W
	15 MHz BW channel ¹ : 14M1F9W	10 MHz BW channel ¹ : 9M40F9W
	20 MHz BW channel ¹ : 18M5F9W	15 MHz BW channel ¹ : 14M1F9W
	NB-IoT SA 200 kHz BW channel: 210KW7D	20 MHz BW channel ¹ : 18M5F9W
		NB-IoT SA 200 kHz BW channel: 210KW7D
OUTPUT POWER (RMS) (W or dBm)	KRC 118 66/1: 1x60W ¹	KRC 118 66/2: 1x80W ¹
	NB-IoT SA 1x20W	NB-IoT SA 1x20W
FCC ID	TA8AKRC11866-1 TA8BKRC11866-1 TA8CKRC11866-1	TA8AKRC11866-2
IC ID	287AB-AS118661 287AB-BS118661 287AB-CS118661	278AB-AS118662
TECHNICAL DESCRIPTION (a brief description of the intended use and operation)	Base station radio	

¹ Including 2 NB-IoT GB carriers.

Signature 
Linda Grell

Date 2018-03-05

No responsibility will be accepted by TÜV SÜD Product Service UK Limited as to the accuracy of the information declared in this document by the manufacturer.

1.5 PRODUCT INFORMATION

1.5.1 Technical Description

The Equipment Under Test (EUT) KRC 118 66/2 is an Ericsson AB Radio Unit working in the public mobile service 1900 MHz band which provides communication connections to 1900 MHz network. The KRC 118 66/2 operates from a -48V DC supply.

The Equipment Under Test (EUT) is shown in the photograph below. A full technical description can be found in the Manufacturer's documentation.

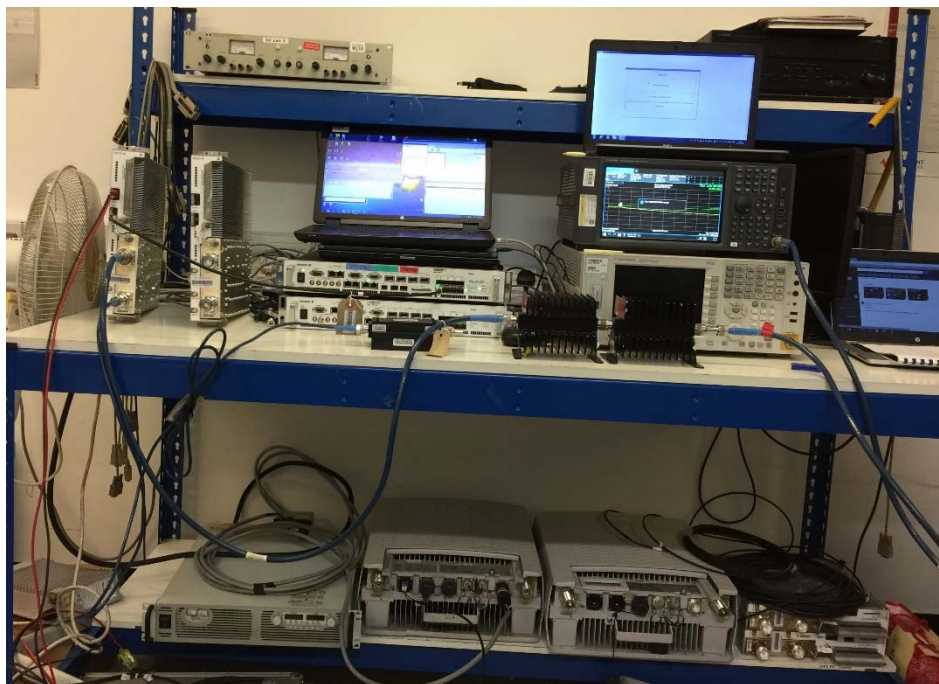

Equipment Under Test

1.6 TEST SETUP

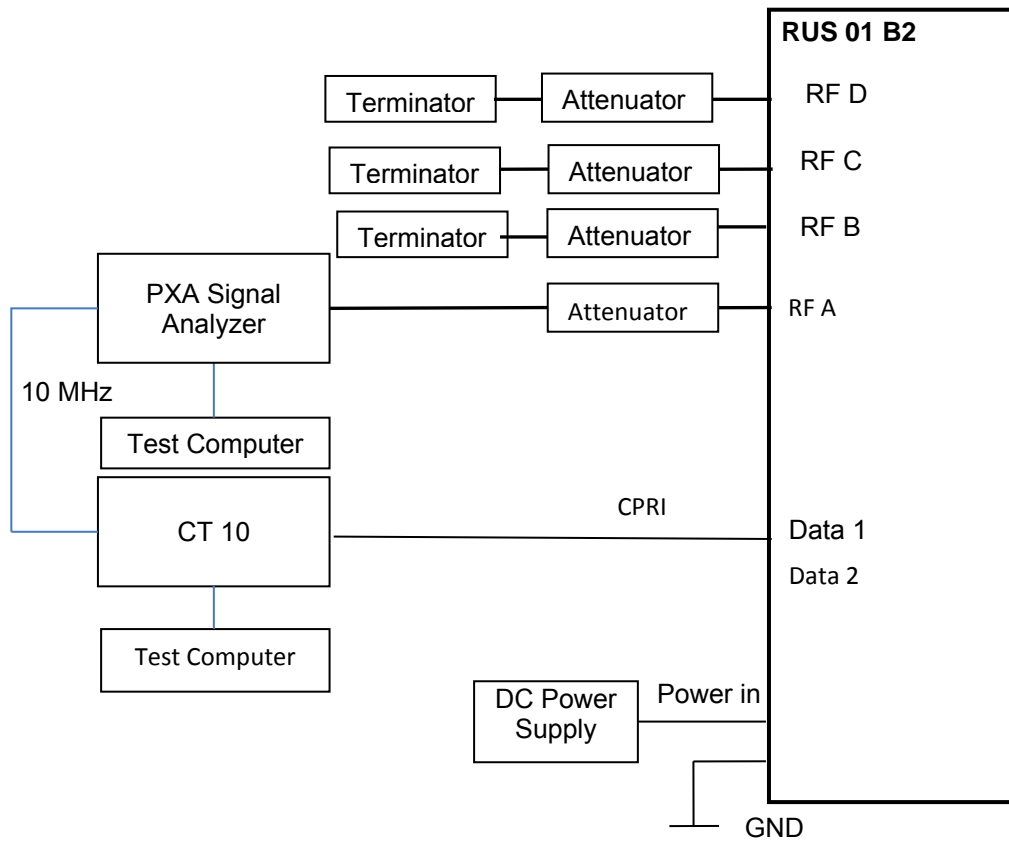

Figure 1, Block diagram of RUS 01 B2 with cables and auxiliary equipment



Product Service

1.7 TEST CONDITIONS

For all tests the EUT was set up in accordance with the relevant test standard and to represent typical operating conditions. Tests were applied with the EUT situated in a shielded enclosure, test laboratories or a chamber as appropriate.

The EUT was powered from a -48V DC supply.

FCC Measurement Facility Registration Number
90987 Octagon House, Fareham Test Laboratory

1.8 DEVIATION FROM THE STANDARD

No deviations from the applicable test standards or test plan were made during testing.

1.9 MODIFICATION RECORD

No modifications were made to the EUT during testing.

1.10 ADDITIONAL INFORMATION

The test results relate only to the item(s) tested RUS 01 B2 KRC 118 66/2
The KRC 118 66/1 is a low power version of the KRC 118 66/2, it has the same Hardware but the output power is 60W and so can also be considered as compliant too.



Product Service

SECTION 2

TEST DETAILS



2.1 MAXIMUM PEAK OUTPUT POWER AND PEAK TO AVERAGE RATIO - CONDUCTED

2.1.1 Specification Reference

FCC CFR 47 Part 2, Clause 2.1046
FCC CFR 47 Part 24, Clause 24.232(a)
Industry Canada RSS-139, Clause 6.4

2.1.2 Date of Test and Modification State

13 February 2018 - Modification State 0

2.1.3 Test Equipment Used

The major items of test equipment used for the above tests are identified in Section 3.1.

2.1.4 Environmental Conditions

Ambient Temperature 21.8°C
Relative Humidity 31.3%

2.1.5 Test Method

All measurements were made in accordance with FCC KDB 971168 D01, clause 5.2.1 and summed in accordance with FCC KDB 662911 D01.

2.1.6 Test Results

Configuration A

Maximum Output Power 49/47.8 dBm

Antenna	LTE Modulation	LTE Carrier Bandwidth	Peak to Average Ratio (PAR) / Output Power		
			Channel Position B		
			PAR (dB)	Average Power	
dBm	dBm/MHz				
A	64QAM	10.0 MHz	6.69	48.57	-
A	64QAM	15.0 MHz	6.76	48.81	-
A	64QAM	20.0 MHz	6.88	48.64	-



Product Service

Antenna A - LTE Modulation 64QAM - LTE Carrier Bandwidth 10.0 MHz - Channel Position B

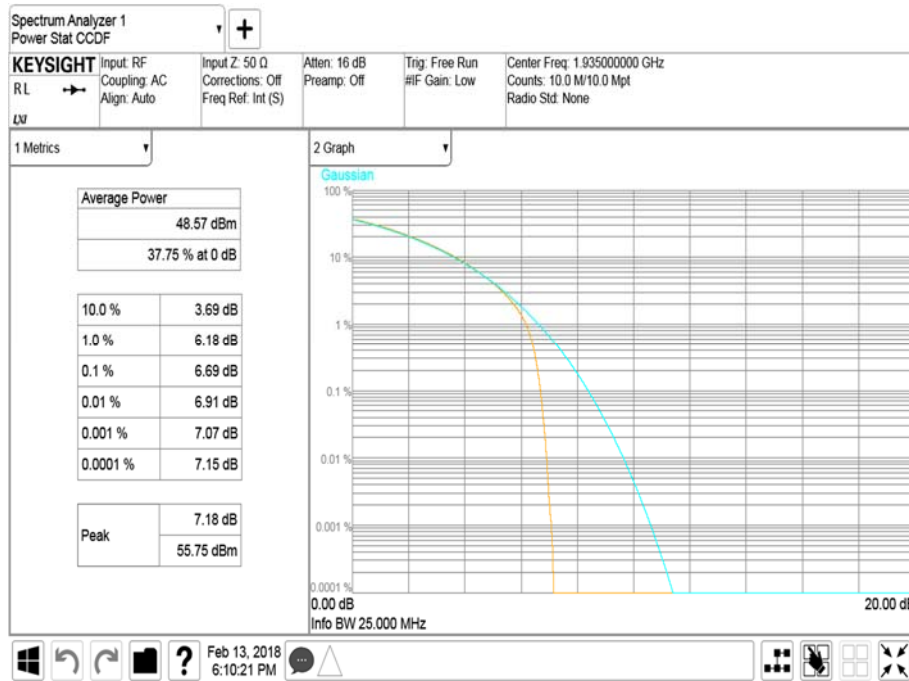

Antenna A - LTE Modulation 64QAM - LTE Carrier Bandwidth 15.0 MHz - Channel Position B

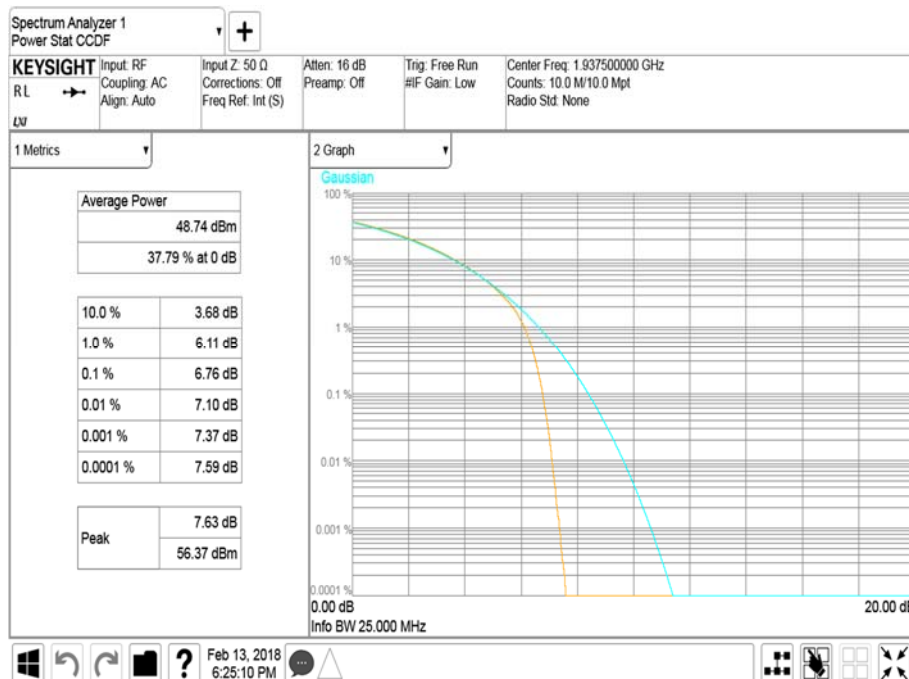



Product Service

Antenna A - LTE Modulation 64QAM - LTE Carrier Bandwidth 20.0 MHz - Channel Position B

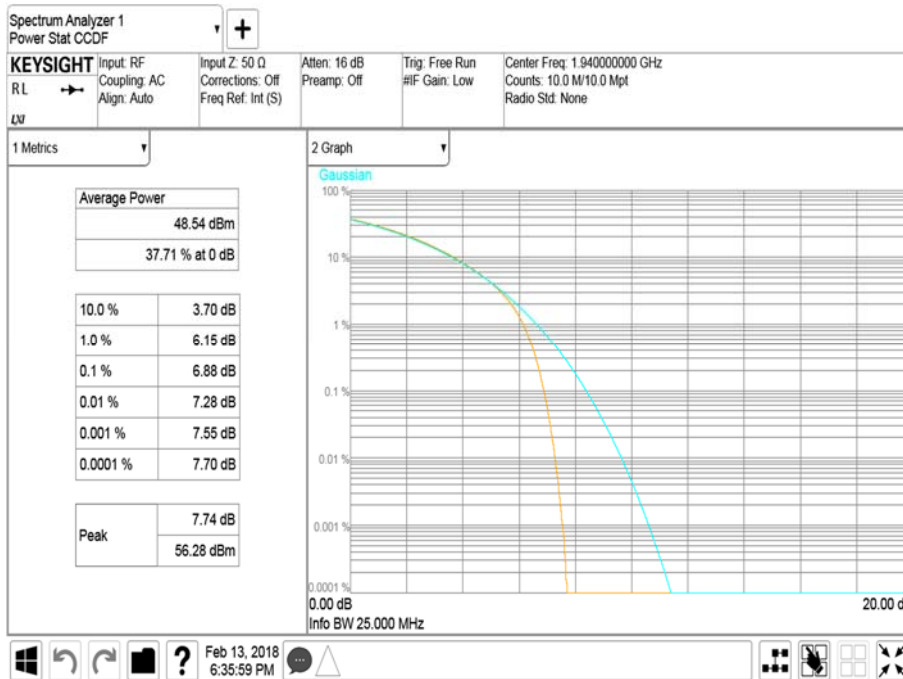

Configuration A

Maximum Output Power 49/47.8 dBm

Antenna	LTE Modulation	LTE Carrier Bandwidth	Peak to Average Ratio (PAR) / Output Power		
			Channel Position T		
			PAR (dB)	Average Power	
dBm	dBm/MHz				
A	64QAM	10.0 MHz	6.63	48.82	-
A	64QAM	15.0 MHz	6.63	48.84	-
A	64QAM	20.0 MHz	6.70	48.66	-



Product Service

Antenna A - LTE Modulation 64QAM - LTE Carrier Bandwidth 10.0 MHz - Channel Position T

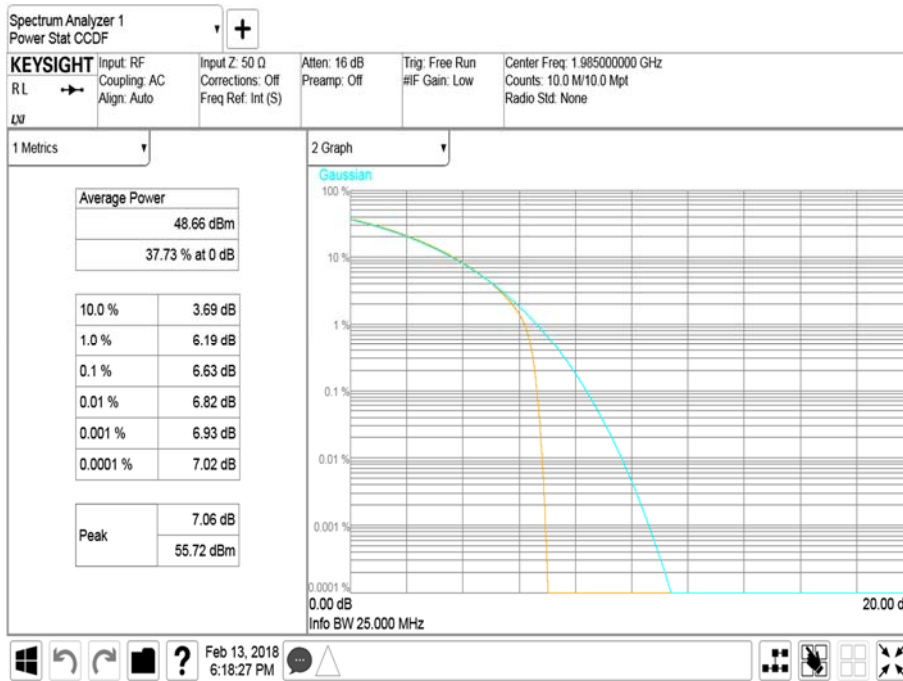

Antenna A - LTE Modulation 64QAM - LTE Carrier Bandwidth 15.0 MHz - Channel Position T

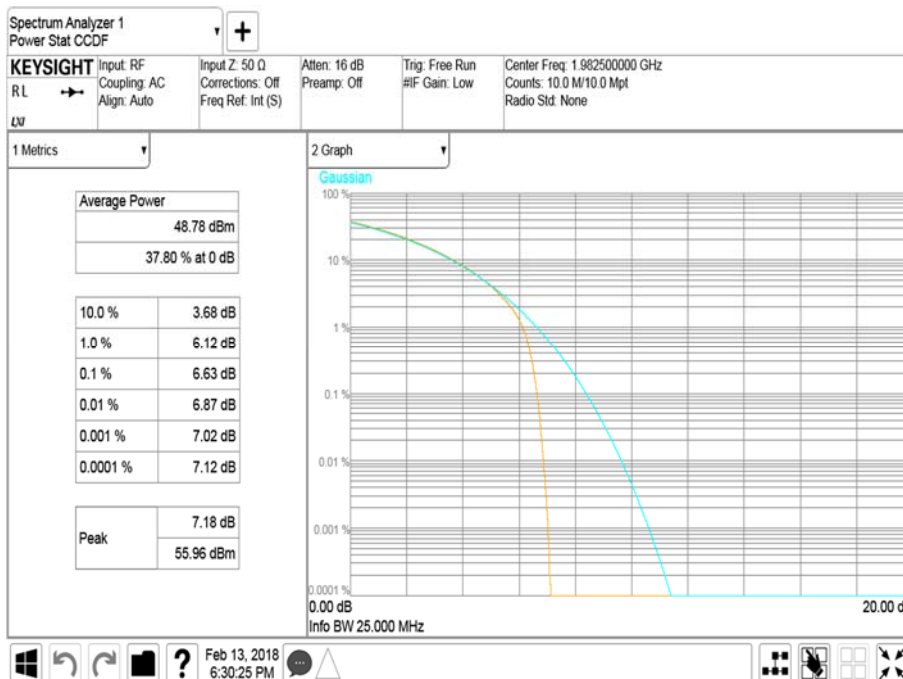



Product Service

Antenna A - LTE Modulation 64QAM - LTE Carrier Bandwidth 20.0 MHz - Channel Position T

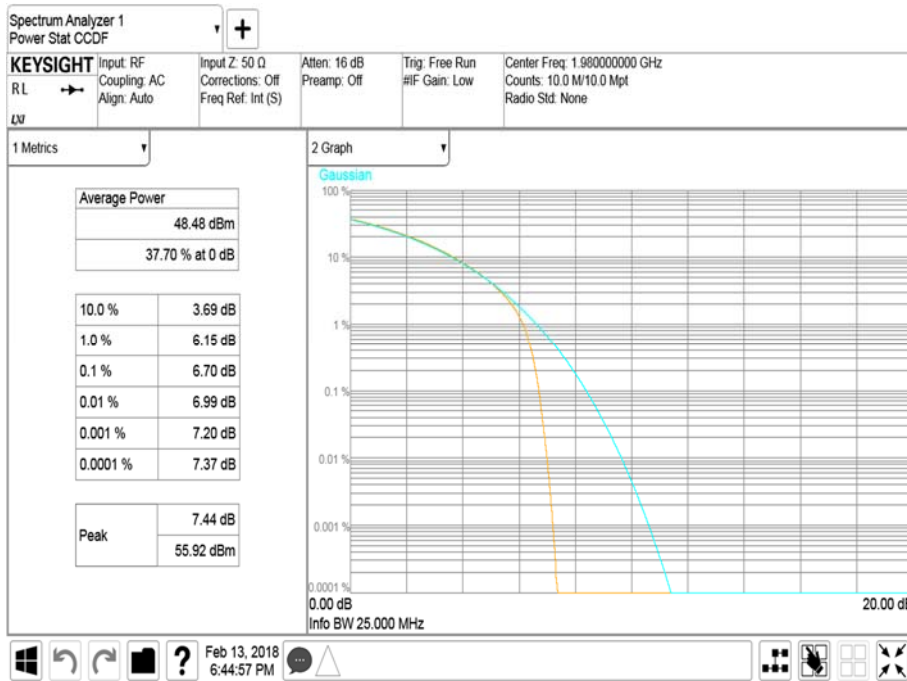

Configuration B

Maximum Output Power 43 dBm

Antenna	NB IoT Modulation	NB IoT Carrier Bandwidth	Peak to Average Ratio (PAR) / Output Power		
			Channel Position B		
			PAR (dB)	Average Power	
dBm	dBm/MHz				
A	QPSK	0.2MHz	4.06	41.95	-



Product Service

Antenna A - NB IoT Modulation QPSK - NB IoT Carrier Bandwidth 0.2MHz - Channel Position B

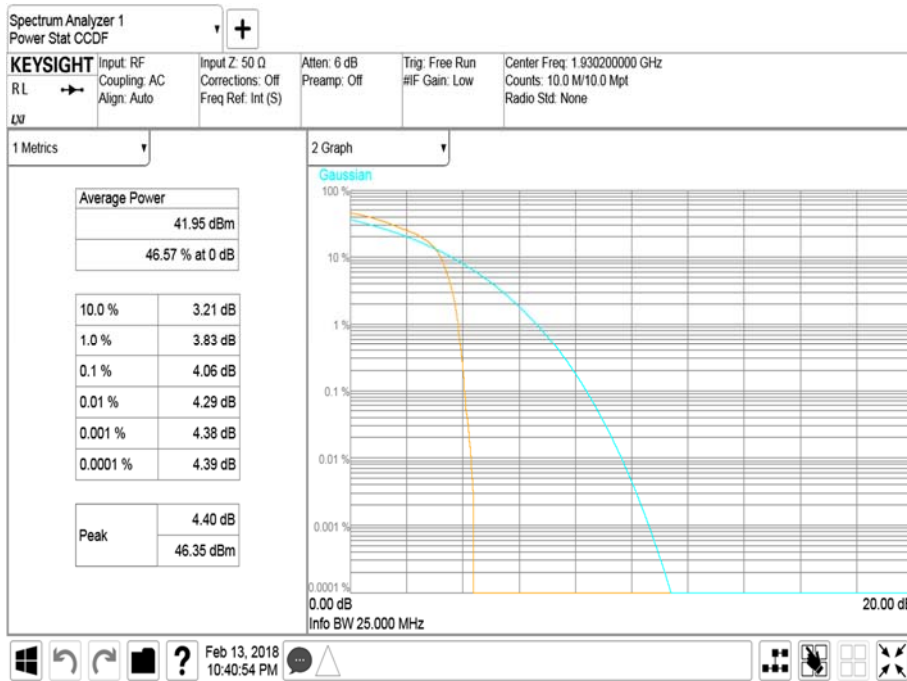

Configuration B

Maximum Output Power 43 dBm

Antenna	NB IoT Modulation	NB IoT Carrier Bandwidth	Peak to Average Ratio (PAR) / Output Power		
			PAR (dB)	Channel Position M	
				Average Power	
				dBm	dBm/MHz
A	QPSK	0.2 MHz	4.09	42.10	-



Product Service

Antenna A - NB IoT Modulation QPSK - NB IoT Carrier Bandwidth 0.2MHz - Channel Position M

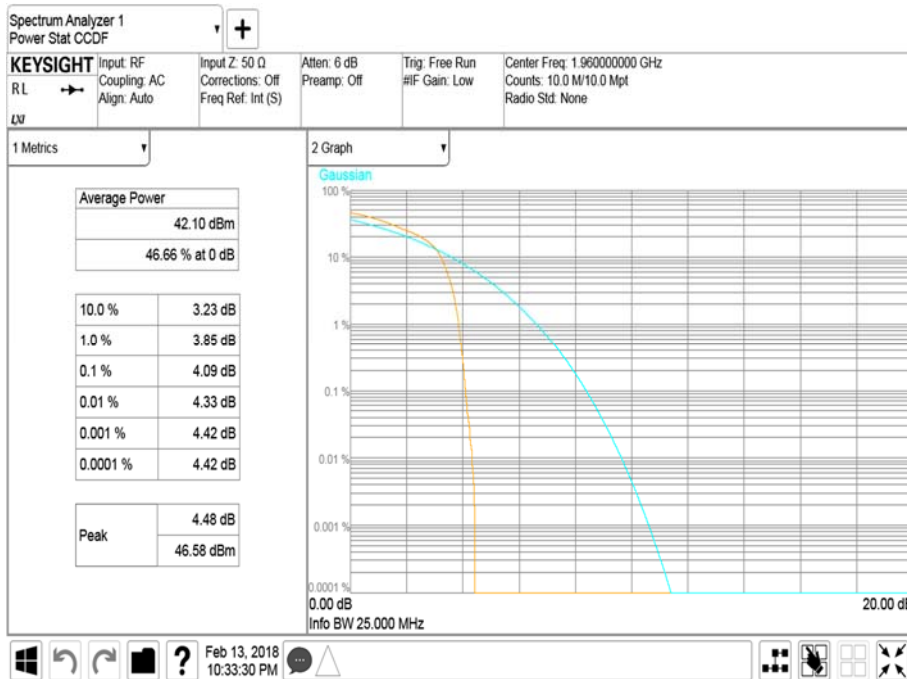

Configuration B

Maximum Output Power 43 dBm

Antenna	NB IoT Modulation	NB IoT Carrier Bandwidth	Peak to Average Ratio (PAR) / Output Power		
			PAR (dB)	Channel Position T	
				Average Power	
				dBm	dBm/MHz
A	QPSK	0.2 MHz	4.03	42.33	-



Product Service

Antenna A - NB IoT Modulation QPSK - NB IoT Carrier Bandwidth 0.2MHz - Channel Position T

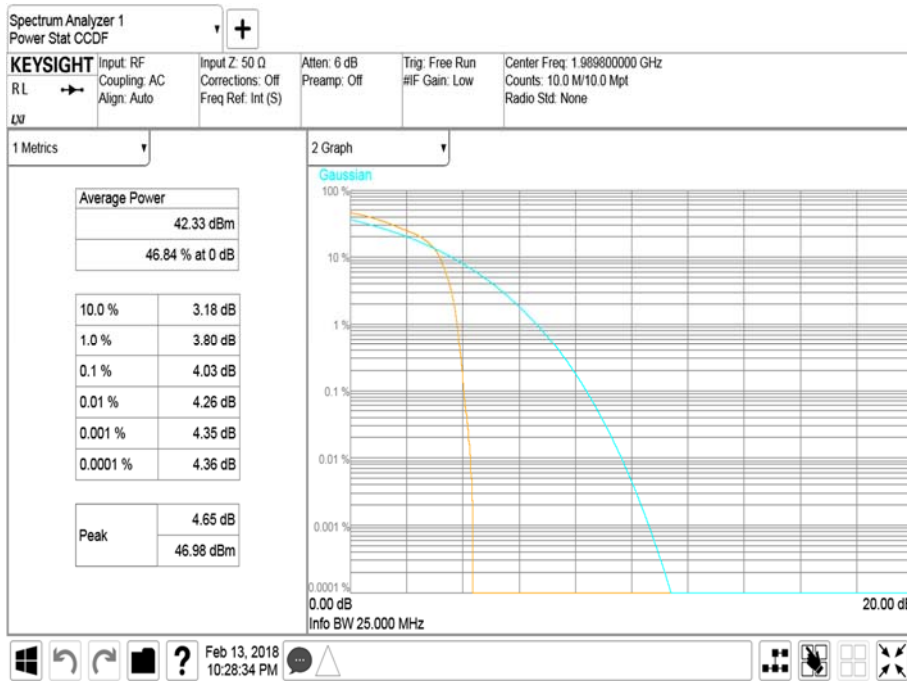

Limit	
Peak Power	≤500 W or ≤+57 dBm
Peak to Average Ratio	13 dB



Product Service

2.2 OCCUPIED BANDWIDTH

2.2.1 Specification Reference

FCC CFR 47 Part 2, Clause 2.1049
 FCC CFR 47 Part 24, Clause 24.238
 Industry Canada RSS-GEN, Clause 6.6

2.2.2 Date of Test and Modification State

13 February 2018 - Modification State 0

2.2.3 Test Equipment Used

The major items of test equipment used for the above tests are identified in Section 3.1.

2.2.4 Environmental Conditions

Ambient Temperature 21.8°C
 Relative Humidity 31.3%

2.2.5 Test Method

All measurements were made in accordance with FCC KDB 971168 D01.

2.2.6 Test Results

Configuration A

Maximum Output Power 49/47.8 dBm

Antenna	LTE Modulation	LTE Carrier Bandwidth	Result (KHz)					
			Channel Position B		Channel Position M		Channel Position T	
			Occupied Bandwidth	-26 dB Bandwidth	Occupied Bandwidth	-26 dB Bandwidth	Occupied Bandwidth	-26 dB Bandwidth
A	64QAM	10.0 MHz	9,422.35	9,790.98	–	–	9,421.70	9,790.10
A	64QAM	15.0 MHz	14,036.85	14,715.83	–	–	14,047.02	14,728.37
A	64QAM	20.0 MHz	18,447.84	19,513.30	–	–	18,466.72	19,580.93



Product Service

Antenna A - LTE Modulation 64QAM - LTE Carrier Bandwidth 10.0 MHz - Channel Position B

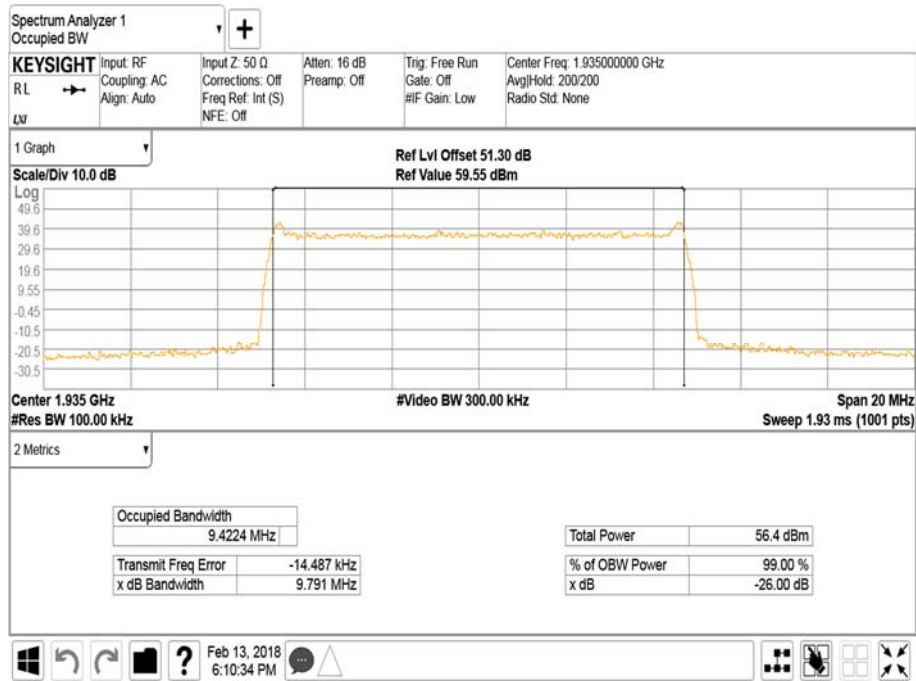

Antenna A - LTE Modulation 64QAM - LTE Carrier Bandwidth 10.0 MHz - Channel Position T

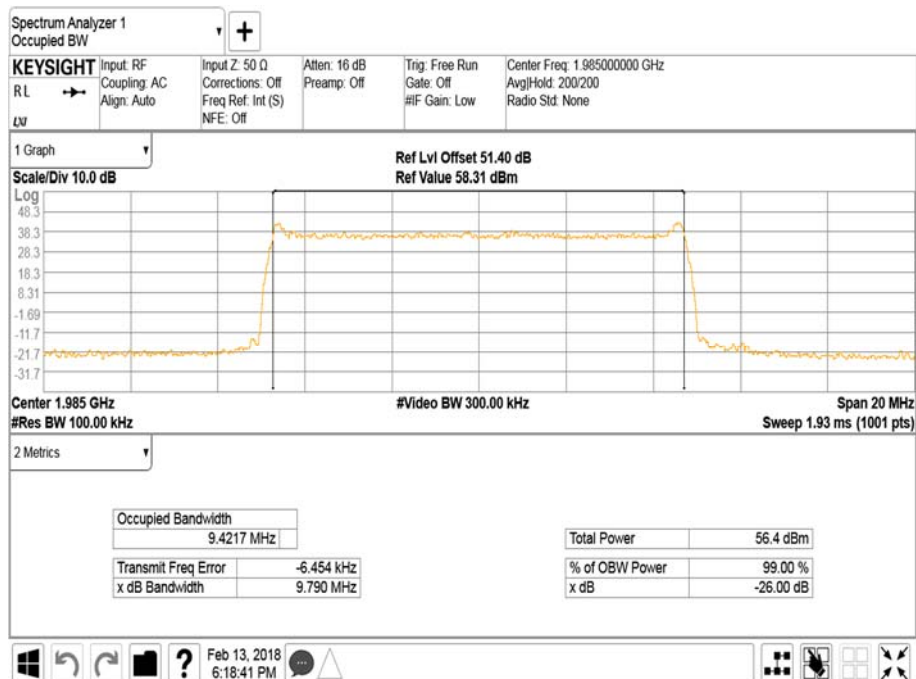



Product Service

Antenna A - LTE Modulation 64QAM - LTE Carrier Bandwidth 15.0 MHz - Channel Position B

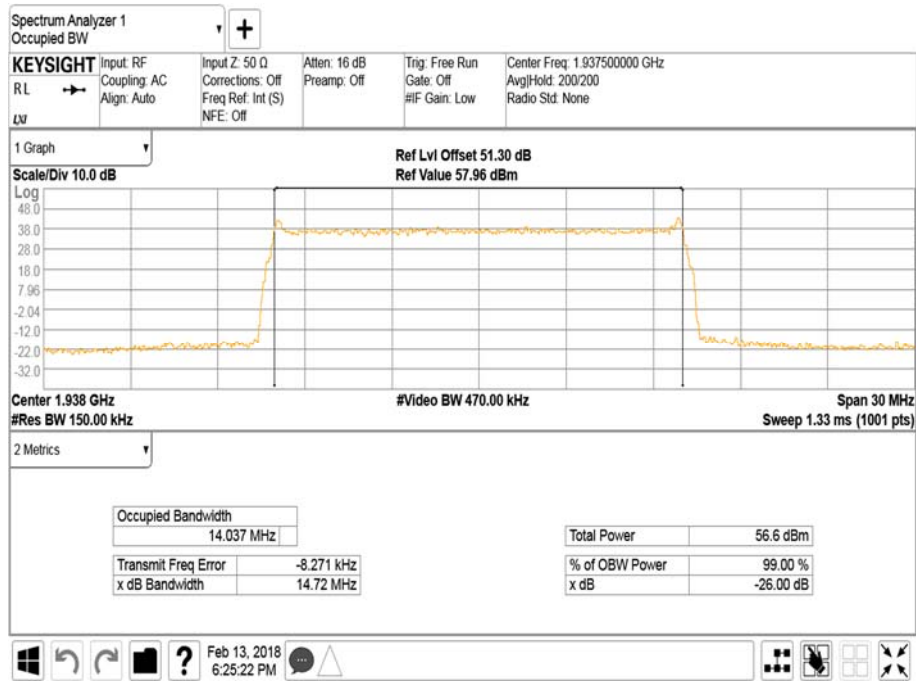

Antenna A - LTE Modulation 64QAM - LTE Carrier Bandwidth 15.0 MHz - Channel Position T

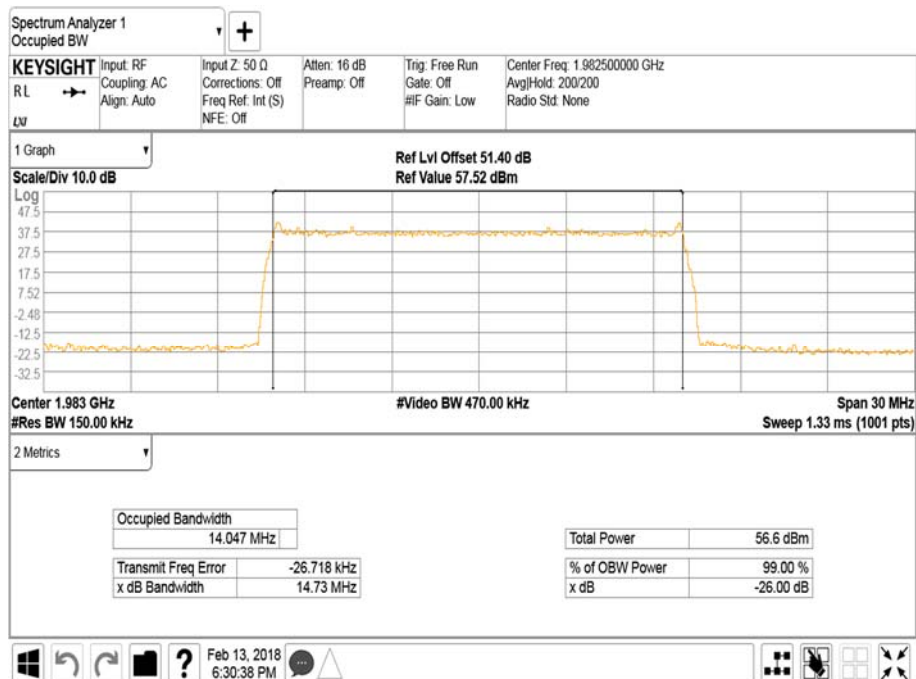



Product Service

Antenna A - LTE Modulation 64QAM - LTE Carrier Bandwidth 20.0 MHz - Channel Position B

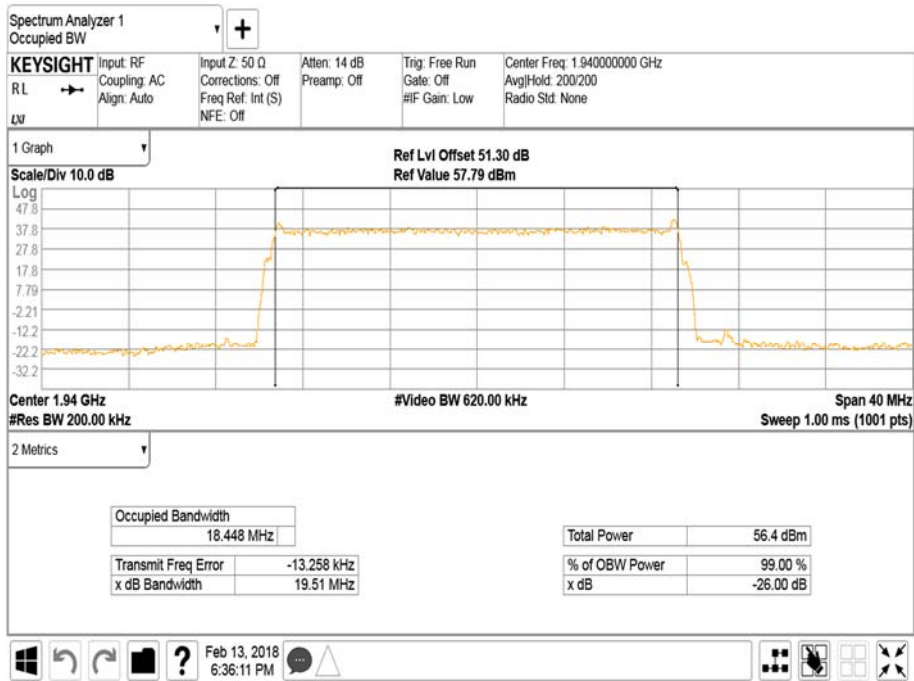

Antenna A - LTE Modulation 64QAM - LTE Carrier Bandwidth 20.0 MHz - Channel Position T

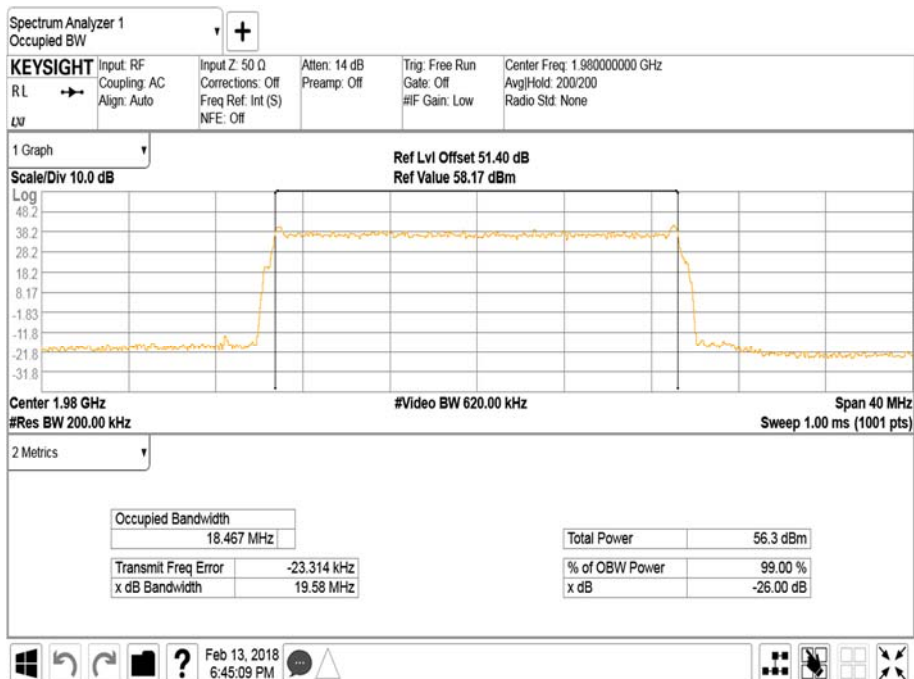



Product Service

Configuration B

Maximum Output Power 43 dBm

Antenna	NB IoT Modulation	NB IoT Carrier Bandwidth	Result (KHz)					
			Channel Position B		Channel Position M		Channel Position T	
			Occupied Bandwidth	-26 dB Bandwidth	Occupied Bandwidth	-26 dB Bandwidth	Occupied Bandwidth	-26 dB Bandwidth
A	QPSK	0.2 MHz	209.43	318.30	209.48	318.40	209.49	318.30

Antenna A - NB IoT Modulation QPSK - NB IoT Carrier Bandwidth 0.2 MHz - Channel Position B

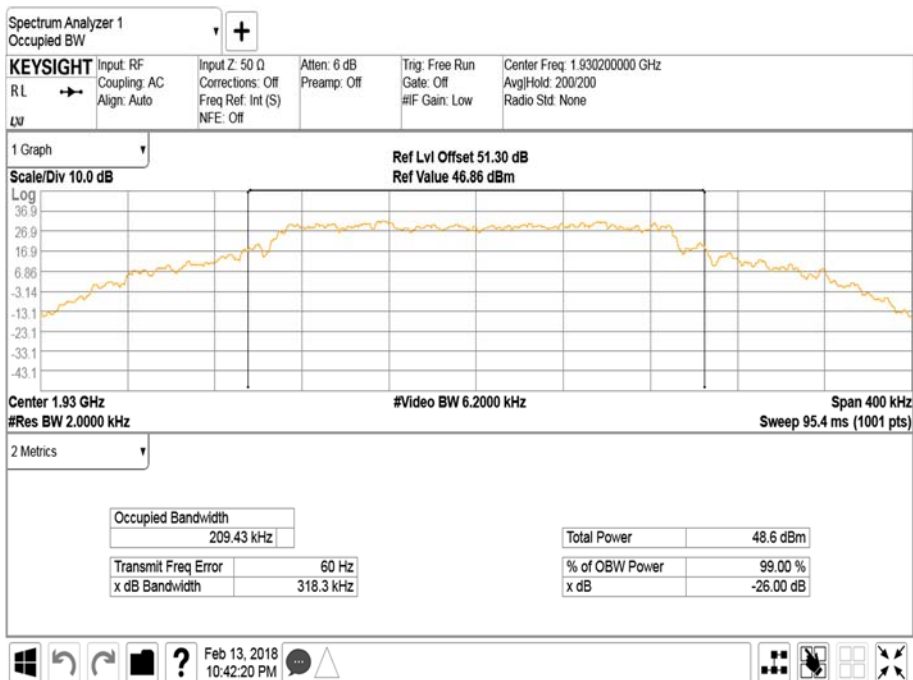



Product Service

Antenna A - NB IoT Modulation QPSK - NB IoT Carrier Bandwidth 0.2 MHz - Channel Position M

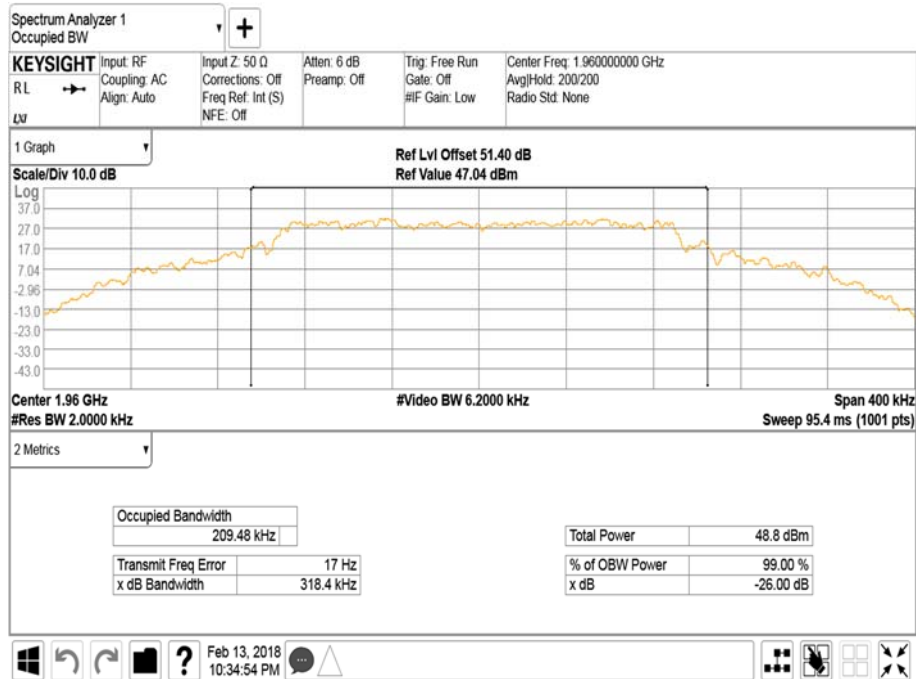

Antenna A - NB IoT Modulation QPSK - NB IoT Carrier Bandwidth 0.2 MHz - Channel Position T

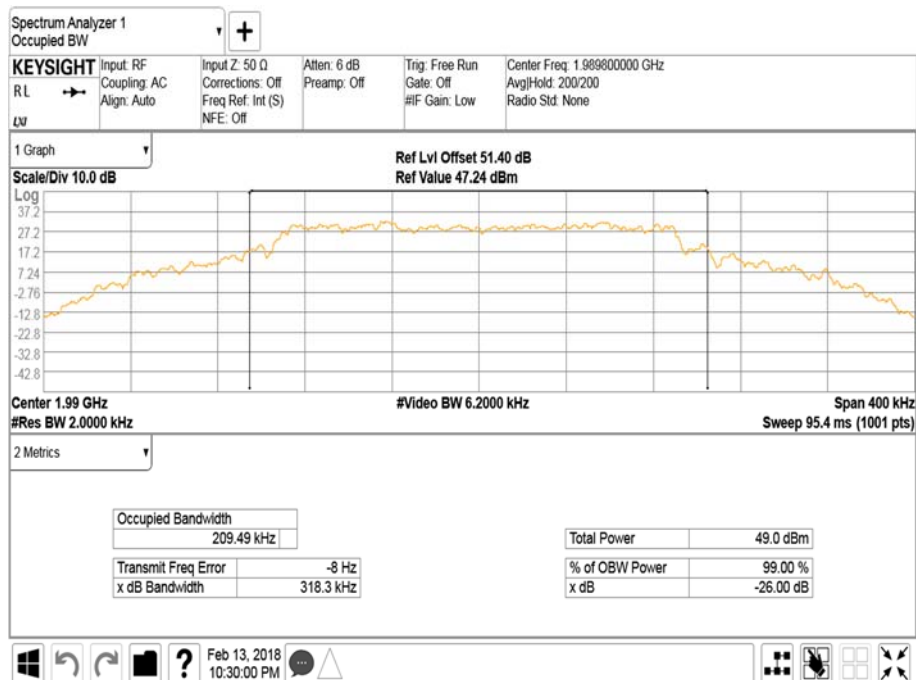



2.3 BAND EDGE

2.3.1 Specification Reference

FCC CFR 47 Part 2, Clause 2.1051
FCC CFR 47 Part 24, Clause 24.238 (b)
Industry Canada RSS-139, Clause 6.5

2.3.2 Date of Test and Modification State

13 February 2018 - Modification State 0

2.3.3 Test Equipment Used

The major items of test equipment used for the above tests are identified in Section 3.1.

2.3.4 Environmental Conditions

Ambient Temperature 21.8°C
Relative Humidity 31.3%

2.3.5 Test Method

All measurements were made in accordance with FCC KDB 971168 D01.

Each antenna port has been declared as being equivalent, therefore measurements were made on one antenna port only. To account for this, the limit was tightened by $10 * \text{Log}(N)$, where N is equal to the number of MIMO antenna ports.

For single carrier, the limit was calculated as being $-13 \text{ dBm} - 10 * \text{Log}(4) = -19 \text{ dBm}$.

For dual carrier, the limit was calculated as being $-13 \text{ dBm} - 10 * \text{Log}(2) = -16 \text{ dBm}$.

2.3.6 Test Results

Configuration A

Maximum Output Power 49/47.8 dBm

Antenna	LTE Modulation	LTE Carrier Bandwidth	Band Edge (MHz)	
			Channel Position B	Channel Position T
A	64QAM	10.0 MHz	1,935.0	1,985.0
A	64QAM	15.0 MHz	1,937.5	1,982.5
A	64QAM	20.0 MHz	1,940.0	1,980.0



Product Service

Antenna A - LTE Modulation 64QAM - LTE Carrier Bandwidth 10.0 MHz - Channel Position B

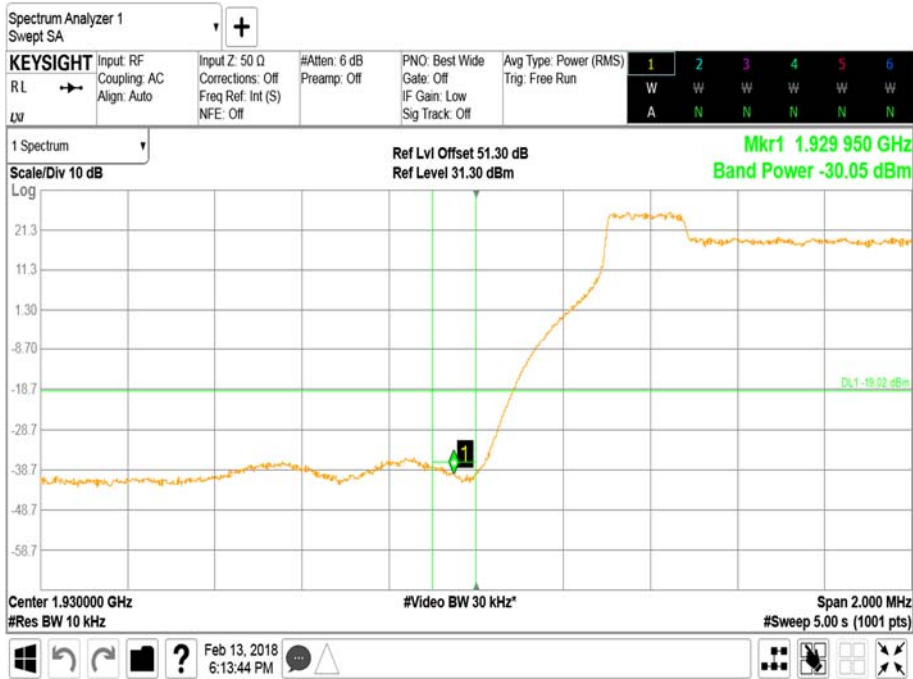

Antenna A - LTE Modulation 64QAM - LTE Carrier Bandwidth 10.0 MHz - Channel Position T





Product Service

Antenna A - LTE Modulation 64QAM - LTE Carrier Bandwidth 15.0 MHz - Channel Position B



Antenna A - LTE Modulation 64QAM - LTE Carrier Bandwidth 15.0 MHz - Channel Position T

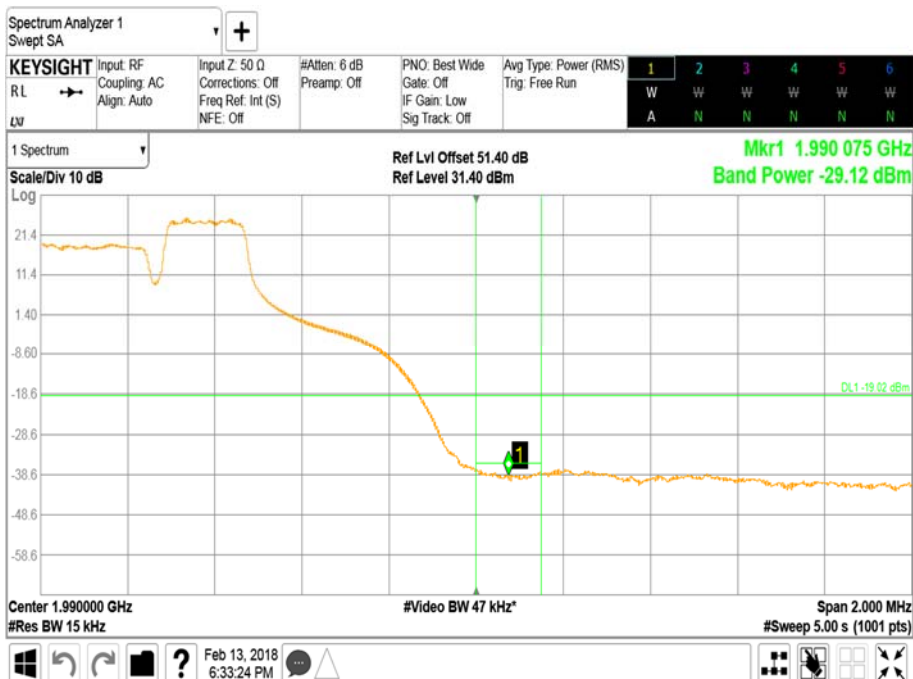



Product Service

Antenna A - LTE Modulation 64QAM - LTE Carrier Bandwidth 20.0 MHz - Channel Position B



Antenna A - LTE Modulation 64QAM - LTE Carrier Bandwidth 20.0 MHz - Channel Position T

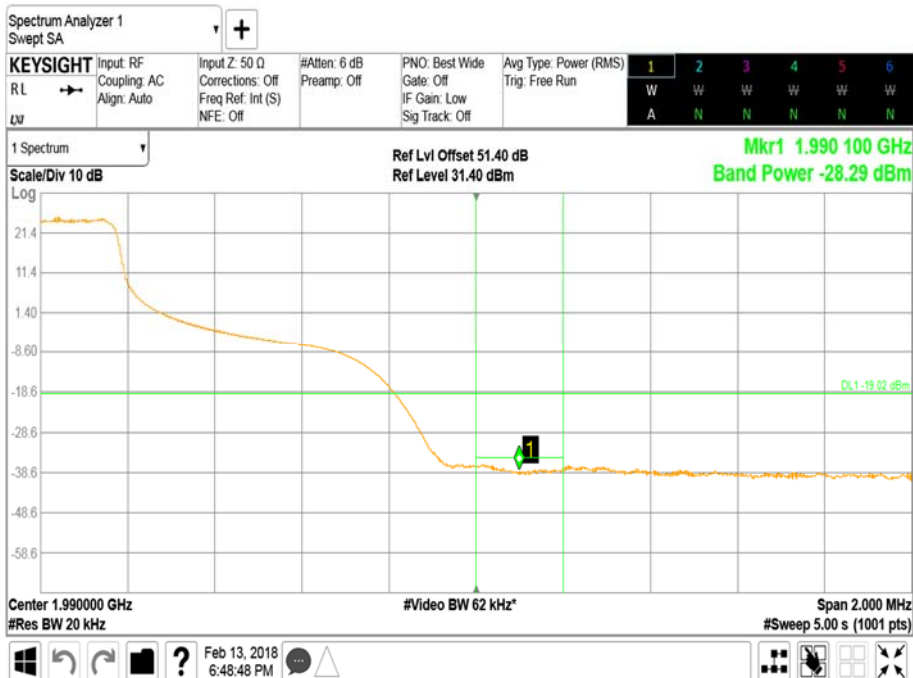



Product Service

Configuration B

Maximum Output Power 43 dBm

Antenna	NB IoT Modulation	NB IoT Carrier Bandwidth	Band Edge (MHz)	
			Channel Position B	Channel Position T
A	QPSK	0.2 MHz	1,930.0	1,990.0

Antenna A - NB IoT Modulation QPSK - NB IoT Carrier Bandwidth 0.2 MHz - Channel Position B

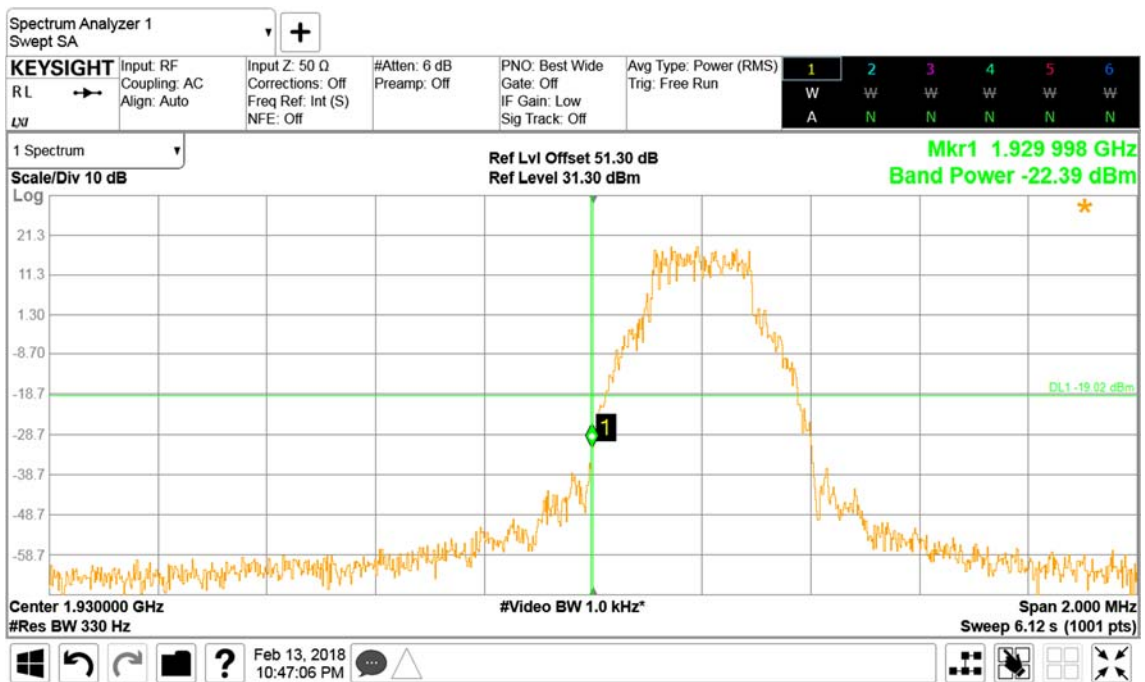



Product Service

Antenna A - NB IoT Modulation QPSK - NB IoT Carrier Bandwidth 0.2 MHz - Channel Position T

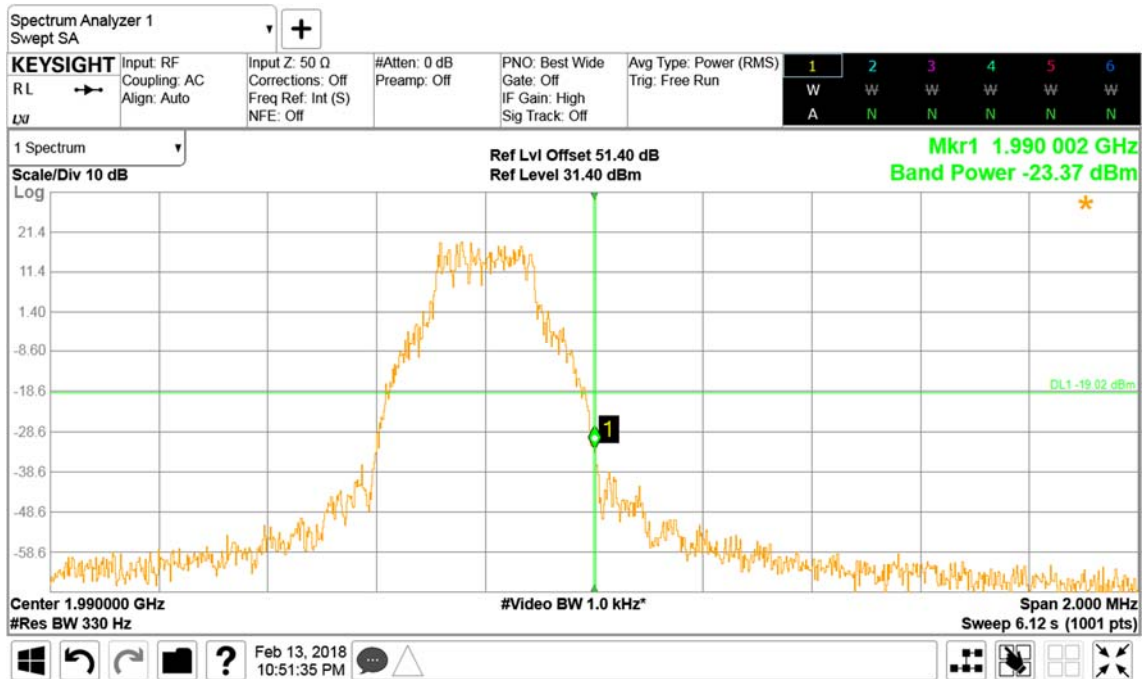

Limit MIMO	-19 dBm
------------	---------



Product Service

2.4 TRANSMITTER SPURIOUS EMISSIONS

2.4.1 Specification Reference

FCC CFR 47 Part 2, Clause 2.1051
FCC CFR 47 Part 24, Clause 24.238 (b)
Industry Canada RSS-139, Clause 6.5

2.4.2 Date of Test and Modification State

13 February 2018 - Modification State 0

2.4.3 Test Equipment Used

The major items of test equipment used for the above tests are identified in Section 3.1.

2.4.4 Environmental Conditions

Ambient Temperature	21.8°C
Relative Humidity	31.3%

2.4.5 Test Method

All measurements were made in accordance with FCC KDB 971168 D01.

Each antenna port has been declared as being equivalent, therefore measurements were made on one antenna port only. To account for this, the limit was tightened by $10 * \text{Log}(N)$, where N is equal to the number of MIMO antenna ports.

For single carrier, the limit was calculated as being $-13 \text{ dBm} - 10 * \text{Log}(4) = -19 \text{ dBm}$.

For dual carrier, the limit was calculated as being $-13 \text{ dBm} - 10 * \text{Log}(2) = -16 \text{ dBm}$.

2.4.6 Test Results

Configuration A

Maximum Output Power 49/47.8 dBm



Product Service

Antenna A - LTE Modulation 64QAM - LTE Carrier Bandwidth 10.0 MHz - Channel Position B - Band 1 - Range 0.009 to 3000 MHz

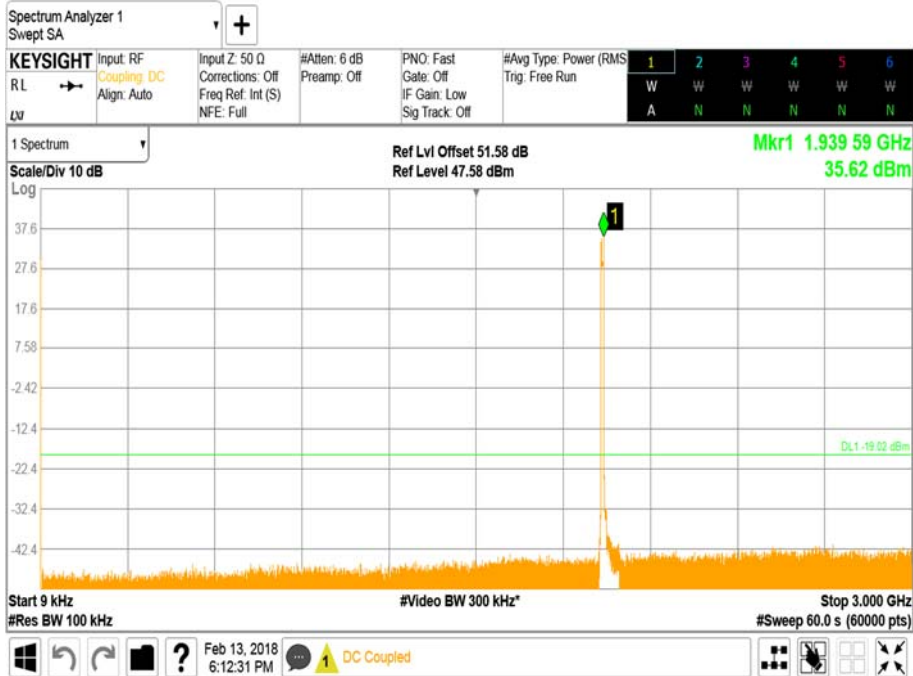

Antenna A - LTE Modulation 64QAM - LTE Carrier Bandwidth 10.0 MHz - Channel Position T - Band 1 - Range 0.009 to 3000 MHz





Product Service

Antenna A - LTE Modulation 64QAM - LTE Carrier Bandwidth 15.0 MHz - Channel Position B - Band 1 - Range 0.009 to 3000 MHz



Antenna A - LTE Modulation 64QAM - LTE Carrier Bandwidth 15.0 MHz - Channel Position T - Band 1 - Range 0.009 to 3000 MHz





Product Service

Antenna A - LTE Modulation 64QAM - LTE Carrier Bandwidth 20.0 MHz - Channel Position B - Band 1 - Range 0.009 to 3000 MHz



Antenna A - LTE Modulation 64QAM - LTE Carrier Bandwidth 20.0 MHz - Channel Position T - Band 1 - Range 0.009 to 3000 MHz

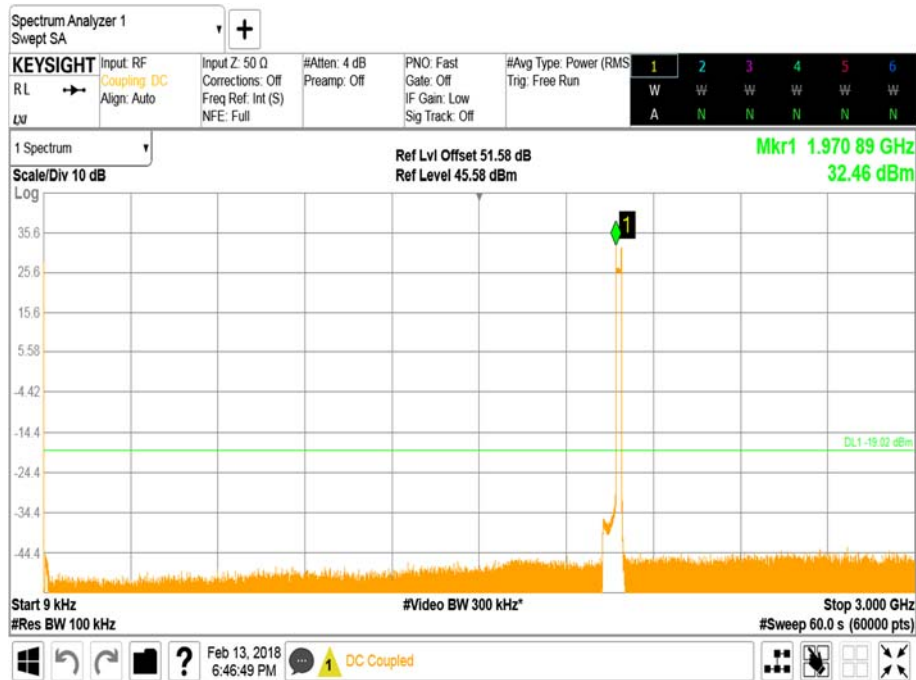



Product Service

Configuration B

Maximum Output Power 43 dBm

Antenna A - NB IoT Modulation QPSK - NB IoT Carrier Bandwidth 0.2 MHz - Channel Position B - Band 1 - Range 9KHz to 3000MHz



Antenna A - NB IoT Modulation QPSK - NB IoT Carrier Bandwidth 0.2 MHz - Channel Position M - Band 1 - Range 9KHz to 3000MHz

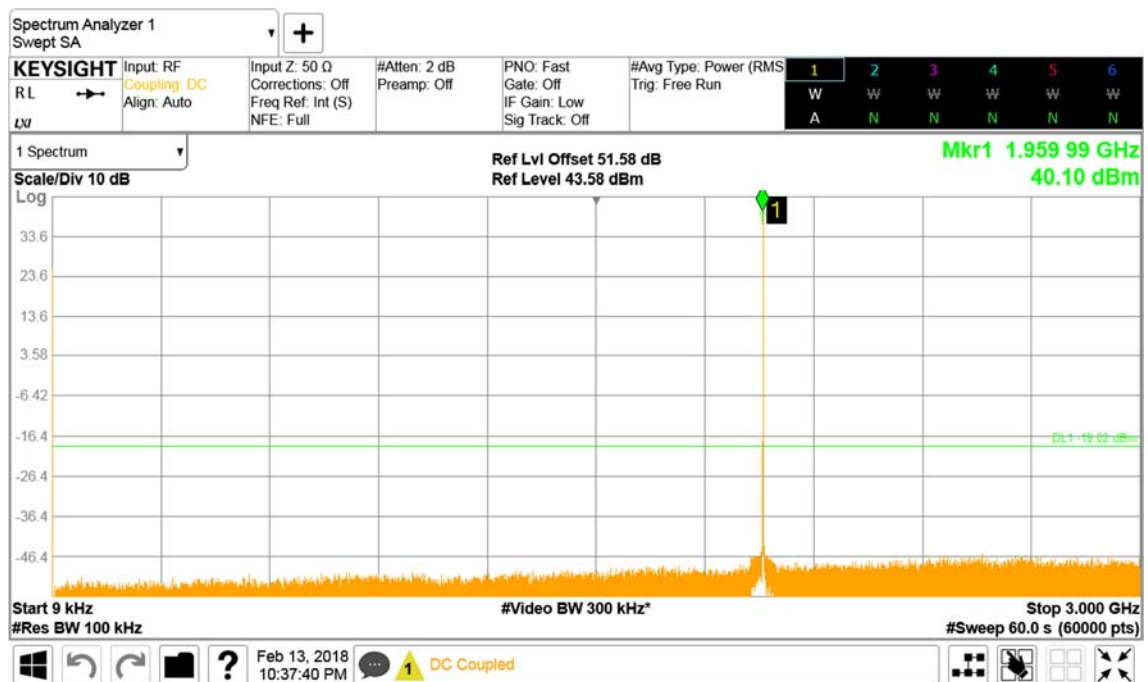



Product Service

Antenna A - NB IoT Modulation QPSK - NB IoT Carrier Bandwidth 0.2 MHz - Channel Position T - Band 1 - Range 9KHz to 3000MHz

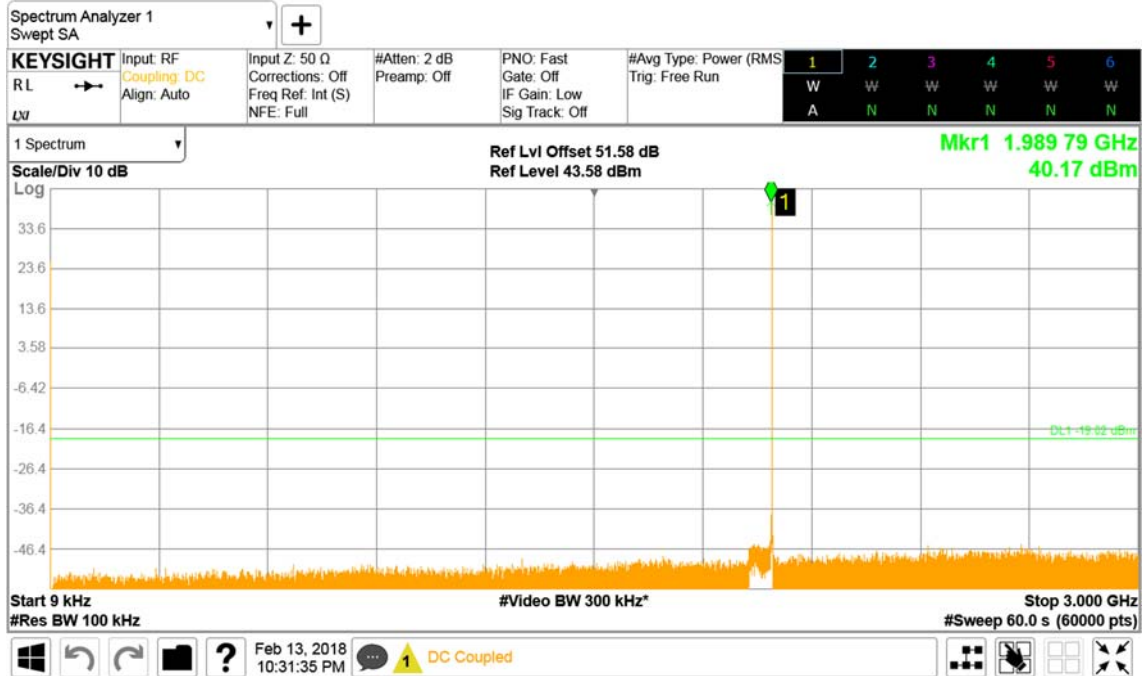

Antenna A - NB IoT Modulation QPSK - NB IoT Carrier Bandwidth 0.2 MHz - Channel Position B - Band 2 - Range 3000MHz to 10000MHz

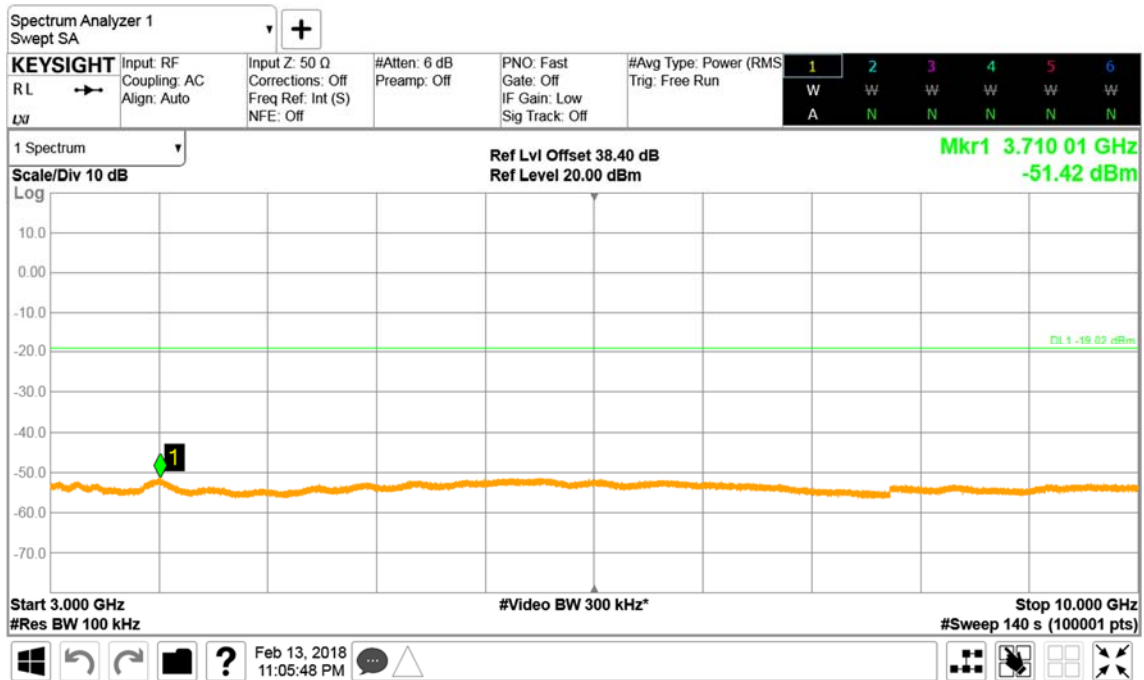



Product Service

Antenna A - NB IoT Modulation QPSK - NB IoT Carrier Bandwidth 0.2 MHz - Channel Position M - Band 2 - Range 3000MHz to 10000MHz

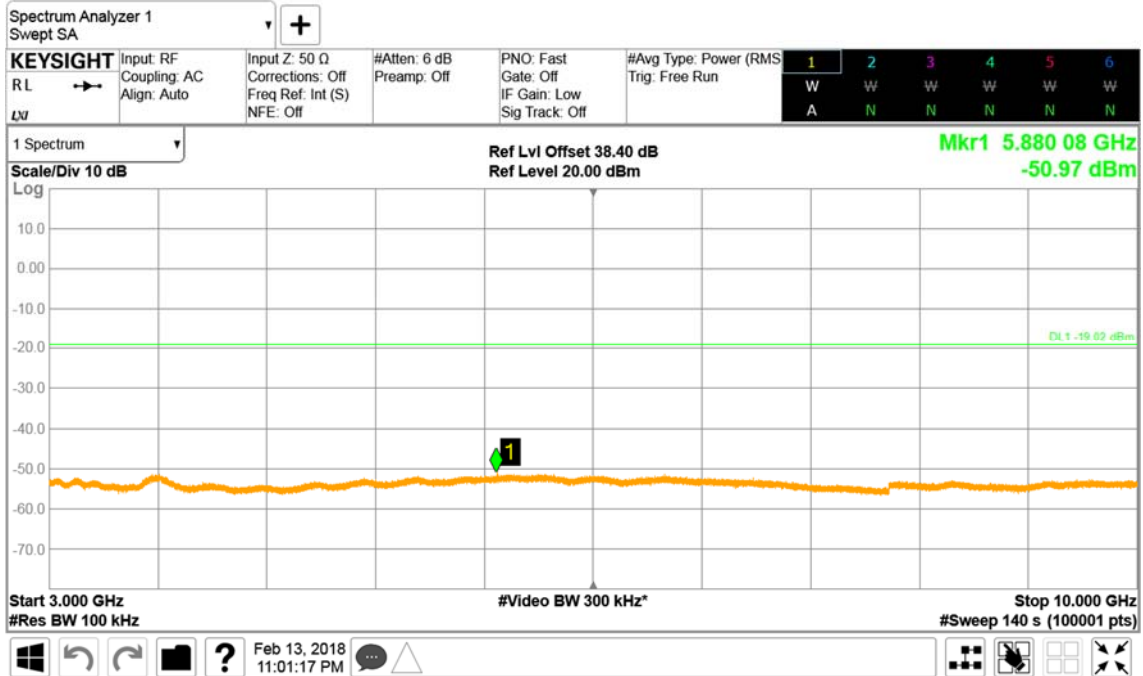

Antenna A - NB IoT Modulation QPSK - NB IoT Carrier Bandwidth 0.2 MHz - Channel Position T - Band 2 - Range 3000MHz to 10000MHz





Product Service

Antenna A - NB IoT Modulation QPSK - NB IoT Carrier Bandwidth 0.2 MHz - Channel Position B - Band 3 - Range 10000MHz to 20000MHz

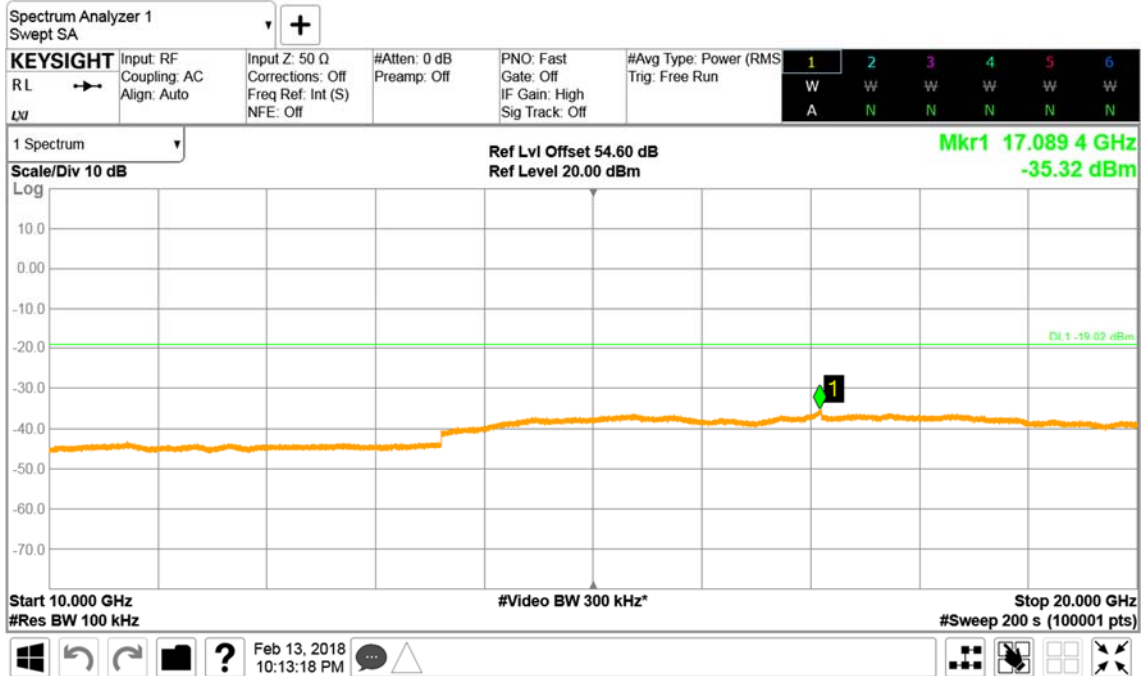

Antenna A - NB IoT Modulation QPSK - NB IoT Carrier Bandwidth 0.2 MHz - Channel Position M - Band 3 - Range 10000MHz to 20000MHz

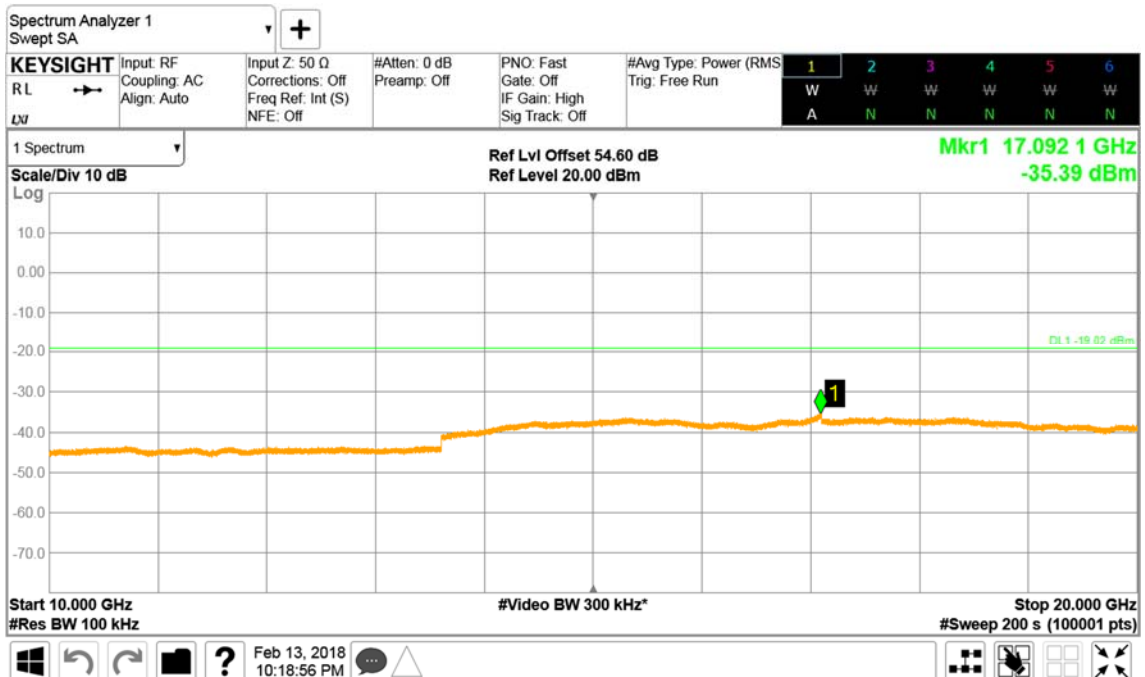



Product Service

Antenna A - NB IoT Modulation QPSK - NB IoT Carrier Bandwidth 0.2 MHz - Channel Position T - Band 3 - Range 10000MHz to 20000MHz

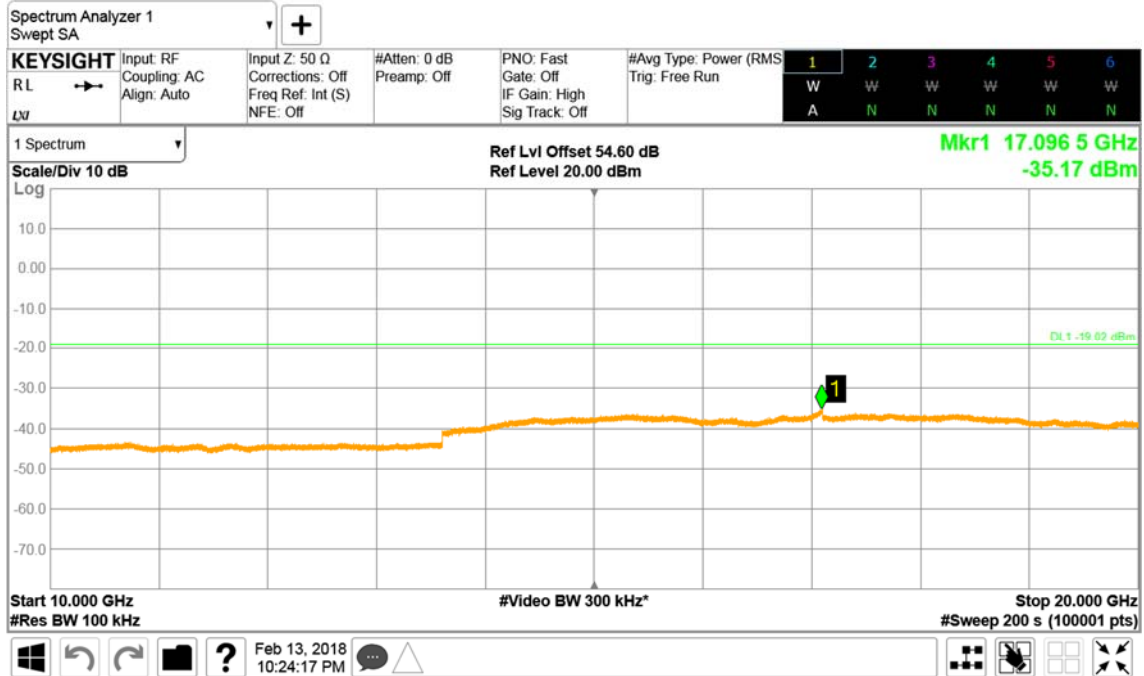

Limit MIMO	-19dBm
------------	--------



Product Service

2.5 RADIATED SPURIOUS EMISSIONS

2.5.1 Specification Reference

FCC CFR 47 Part 2, Clause 2.1053
FCC CFR 47 Part 24, Clause 24.238

2.5.2 Date of Test and Modification State

04 February 2018 - Modification State 0

2.5.3 Test Equipment Used

The major items of test equipment used for the above tests are identified in Section 3.1.

2.5.4 Environmental Conditions

Ambient Temperature 18.9°C
Relative Humidity 33 %

2.5.5 Test Method

The test was applied in accordance with test method requirements of ANSI/TIA-603-C-2004.

A preliminary profile of the Spurious Radiated Emissions was obtained by operating the EUT on a remotely controlled turntable within the chamber. Measurements of emissions from the EUT were obtained with the Measurement Antenna in both Horizontal and Vertical Polarisations.

The Applicant declared that the highest internally generated frequency would be up to 2000MHz and so the upper limit for measurement was calculated at 10 times this, which is 20GHz.

Emissions identified within the range 30MHz – 20GHz were then formally measured using a Peak detector as the worst case.

In the frequency Range 30MHz – 1GHz, the measurement was performed with a resolution bandwidth of 100kHz.

In the frequency Range 1GHz – 20GHz, the measurement was performed with a resolution bandwidth of 1MHz.

The measurements were performed at a 3m distance unless otherwise stated.

The limits for Spurious Emissions have been calculated, as shown below using the following formula:

Field Strength of Carrier - $(43 + 10\text{Log}(P))$ dB

Where:

Field Strength is measured in dB μ V/m

P is measured Transmitter Power in Watts



Product Service

Determination of Spurious Emission Limit

As the EUT does not have an integral antenna, the field strength of the carrier has been calculated assuming that the power is to be fed to a half-wave tuned dipole as per 2.1053 (a).

$$E_{(v/m)} = (30 \times G_i \times P_o)^{0.5} / d$$

Where G_i is the antenna gain of an ideal half-wave dipole,
 P_o is the power out of the transceiver in W,
 d is the measurement distance in meter.

Therefore at 3m measurement distance the field strength using the lowest transceiver output power would be:

$$E_{(v/m)} = (30 \times 1.64 \times 60)^{0.5} / 3 = 9.84V/m = 139.86dB\mu V/m$$

As per 24.238(1)) the spurious emission must be attenuated by $43 + 10\log(P_o)$ dB this gives:

$$43 + 10\log(60) = 60.78dB$$

Therefore the limit at 3m measurement distance is:

$$139.86 - 60.78 = 79.08 \text{ dB}\mu V/m$$

This limit has been used to determine Pass or Fail for the harmonics measured and detailed in the following results.

2.5.6 Test Results

Configuration A-

Maximum Output Power 49/47.8 dBm, LTE Bandwidth 10.0MHz



Product Service

Channel Position B – QPSK / Bandwidth 10.0MHz – 30MHz – 1GHz

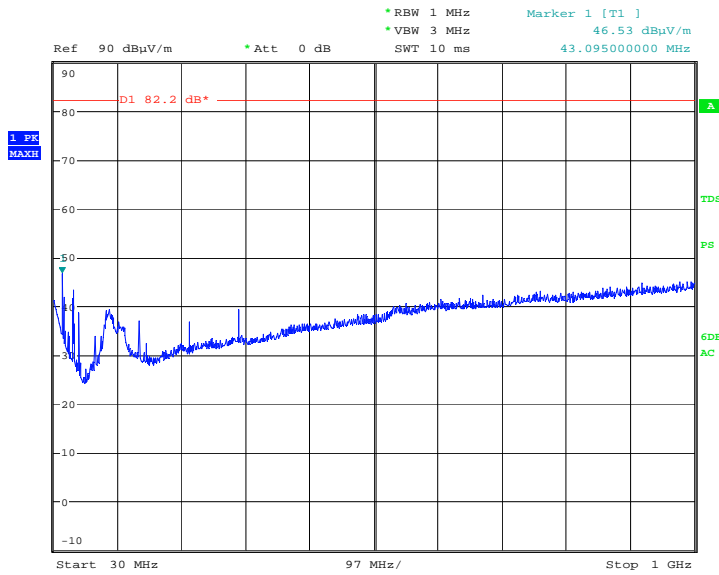

Date: 4.FEB.2018 09:40:30

Channel Position T – QPSK / Bandwidth 10.0MHz – 30MHz – 1GHz

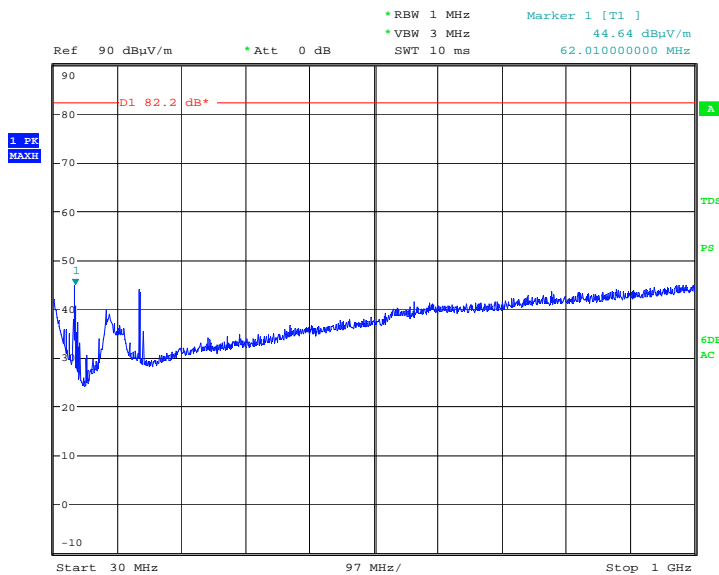

Date: 4.FEB.2018 09:45:44



Product Service

Channel Position B – QPSK / Bandwidth 10.0MHz – 1GHz – 8GHz

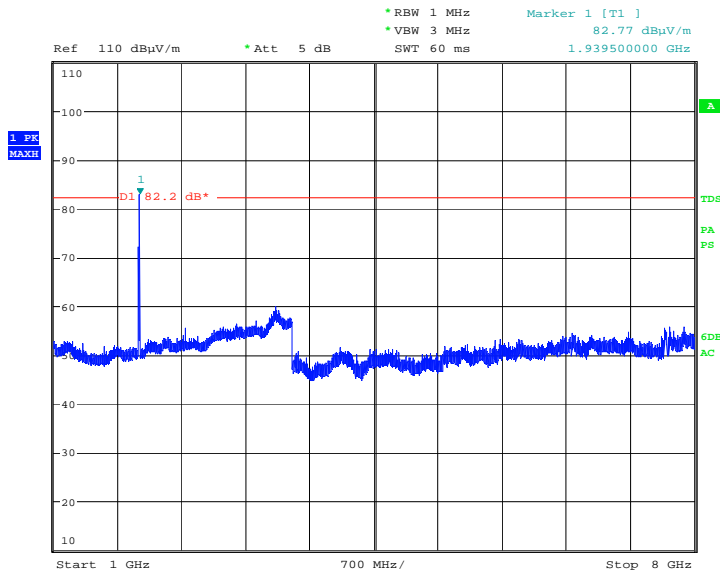

Date: 4.FEB.2018 12:05:59

Channel Position T – QPSK / Bandwidth 10.0MHz – 1GHz – 8GHz

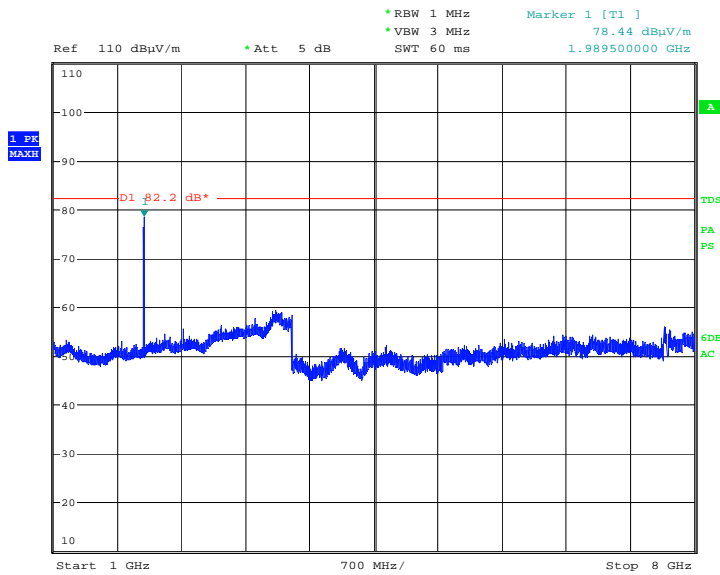

Date: 4.FEB.2018 12:13:23



Product Service

Channel Position B – QPSK / Bandwidth 10.0MHz – 8GHz – 18GHz

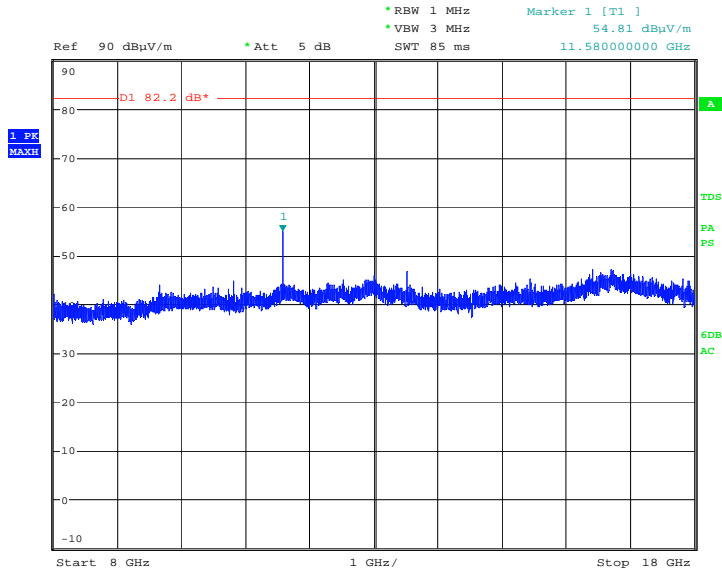

Date: 4.FEB.2018 10:24:49

Channel Position T – QPSK / Bandwidth 10.0MHz – 8GHz – 18GHz

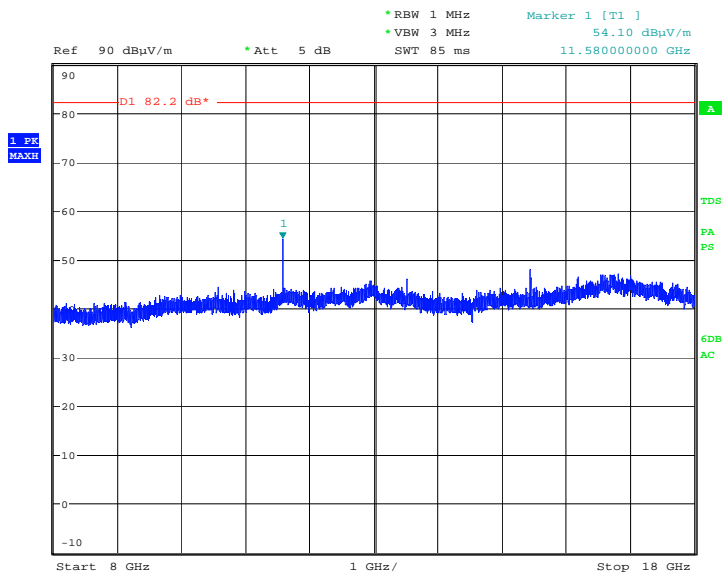

Date: 4.FEB.2018 10:21:25



Product Service

Channel Position B – QPSK / Bandwidth 10.0MHz – 18GHz – 20GHz

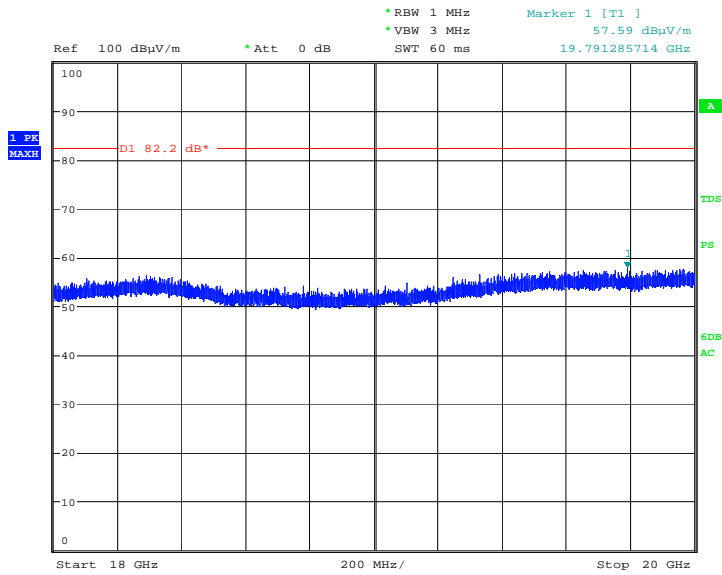

Date: 4.FEB.2018 08:08:24

Channel Position T – QPSK / Bandwidth 10.0MHz – 18GHz – 20GHz

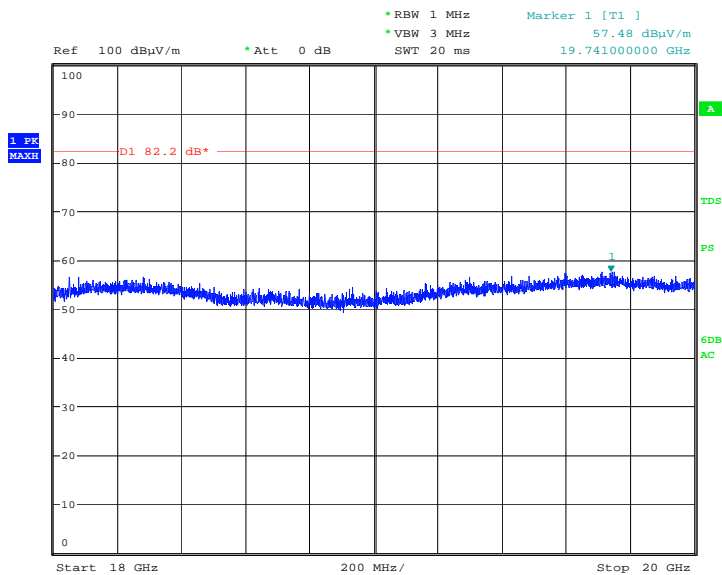

Date: 4.FEB.2018 08:11:25



Product Service

Maximum Output Power 49/47.8 dBm, LTE Bandwidth 15.0MHz

Channel Position B – QPSK / Bandwidth 15.0MHz – 30MHz – 1GHz

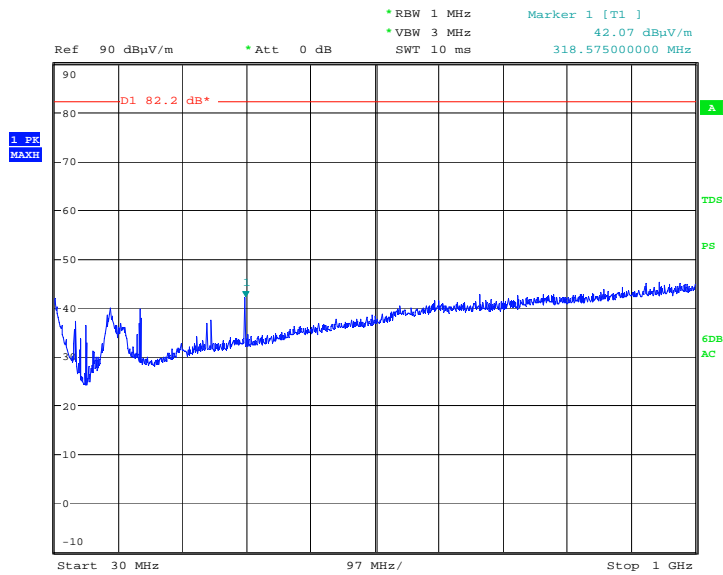

Date: 4.FEB.2018 09:25:37

Channel Position T – QPSK / Bandwidth 15.0MHz – 30MHz – 1GHz

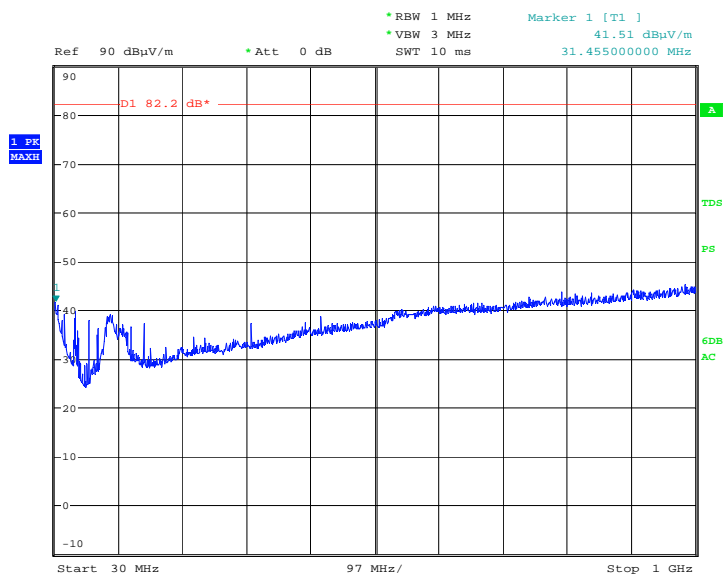

Date: 4.FEB.2018 09:29:39



Product Service

Channel Position B – QPSK / Bandwidth 15.0MHz – 1GHz – 8GHz

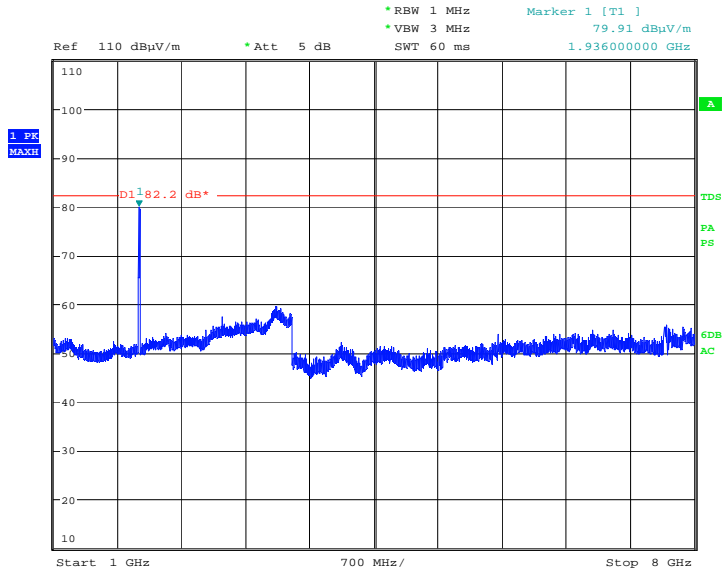

Date: 4.FEB.2018 11:57:13

Channel Position T – QPSK / Bandwidth 15.0MHz – 1GHz – 8GHz

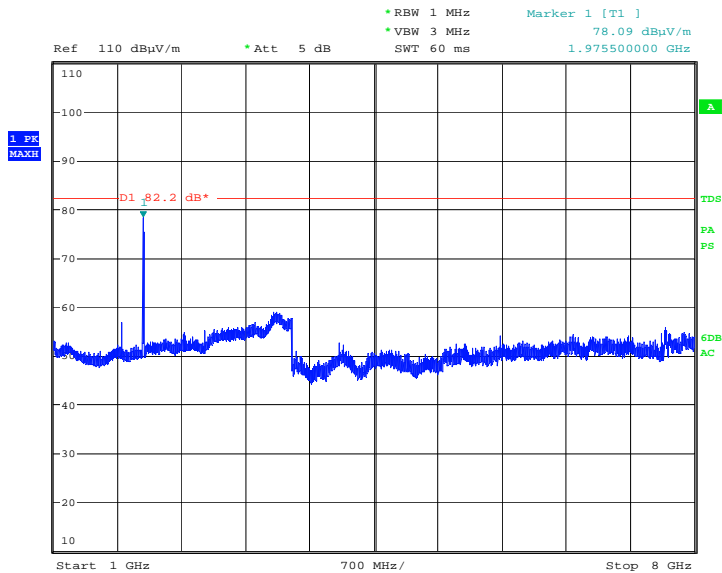

Date: 4.FEB.2018 12:01:22



Product Service

Channel Position B – QPSK / Bandwidth 15.0MHz – 8GHz – 18GHz

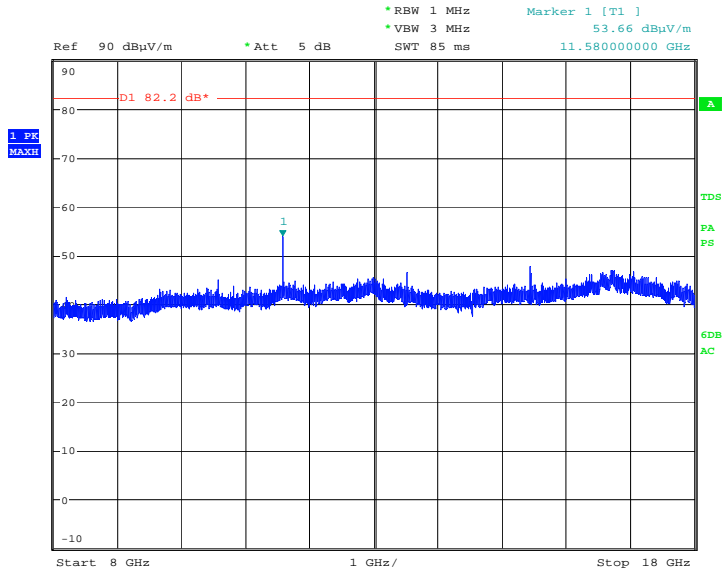

Date: 4.FEB.2018 10:29:29

Channel Position T – QPSK / Bandwidth 15.0MHz – 8GHz – 18GHz

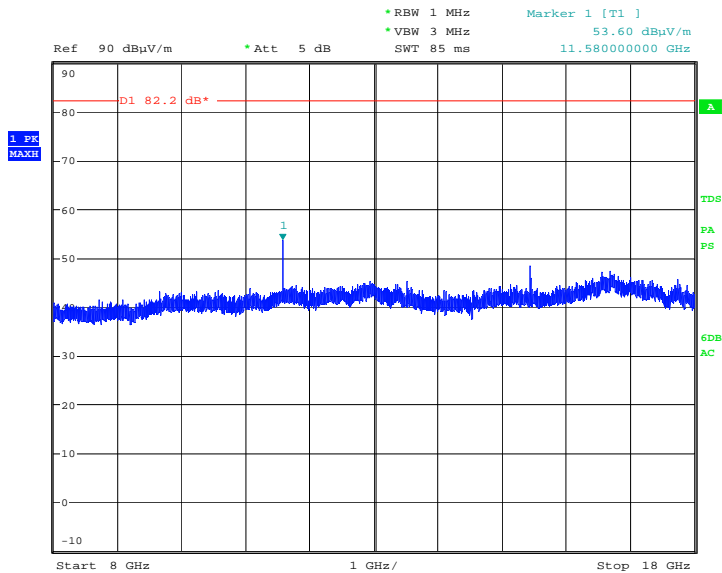

Date: 4.FEB.2018 10:33:21



Product Service

Channel Position B – QPSK / Bandwidth 15.0MHz – 18GHz – 20GHz

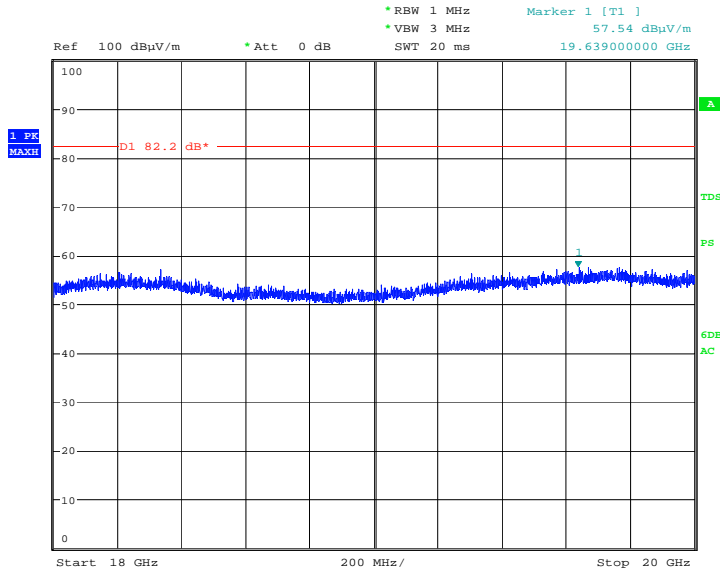

Date: 4.FEB.2018 08:14:33

Channel Position T – QPSK / Bandwidth 15.0MHz – 18GHz – 20GHz

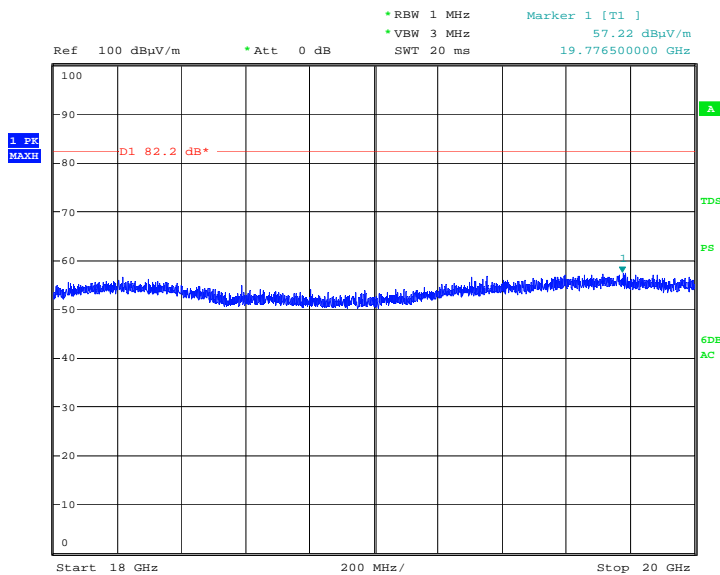

Date: 4.FEB.2018 08:18:05



Product Service

Maximum Output Power 49/47.8 dBm, LTE Bandwidth 20.0MHz

Channel Position B – QPSK / Bandwidth 20.0MHz – 30MHz – 1GHz

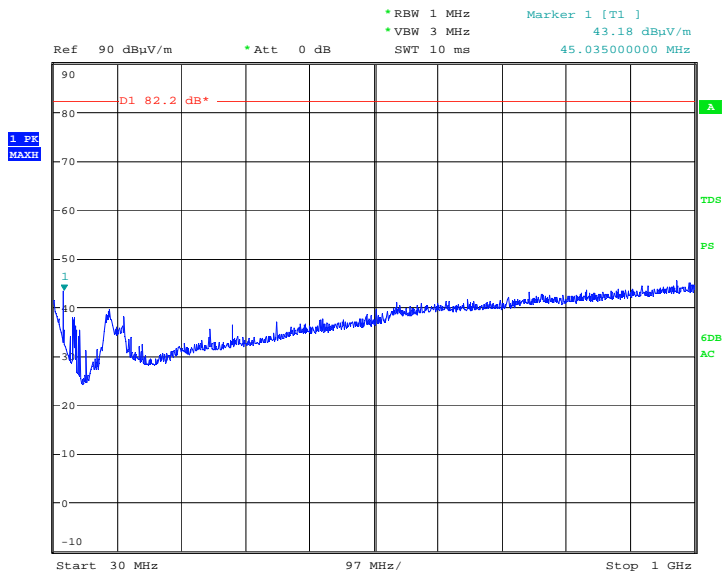

Date: 4.FEB.2018 09:21:40

Channel Position T – QPSK / Bandwidth 20.0MHz – 30MHz – 1GHz

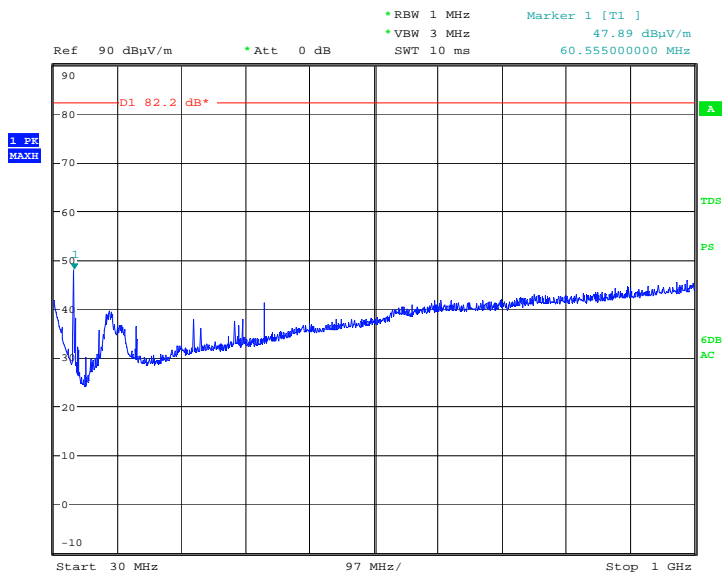

Date: 1.JAN.2003 00:58:41



Product Service

Channel Position B – QPSK / Bandwidth 20.0MHz – 1GHz – 8GHz

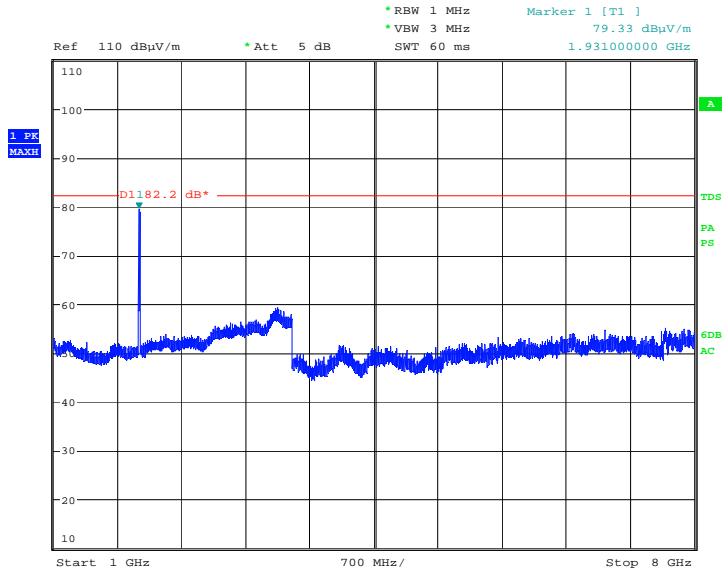

Date: 4.FEB.2018 11:49:26

Channel Position T – QPSK / Bandwidth 20.0MHz – 1GHz – 8GHz

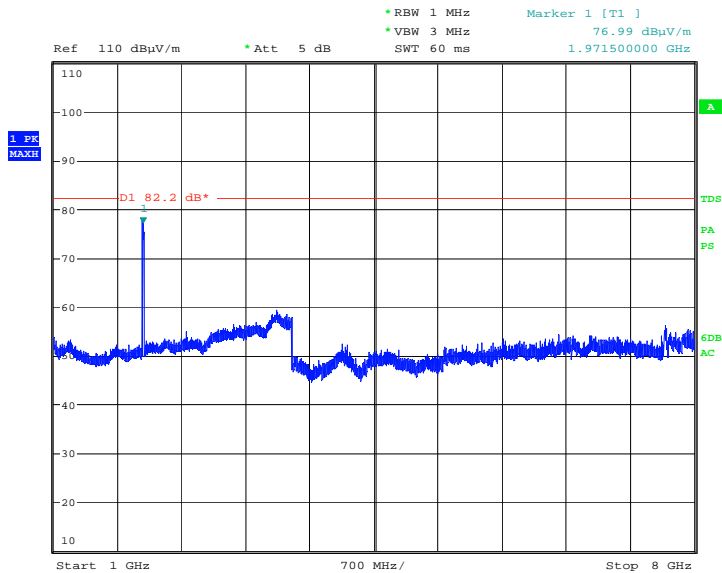

Date: 4.FEB.2018 11:45:43



Product Service

Channel Position B – QPSK / Bandwidth 20.0MHz – 8GHz – 18GHz

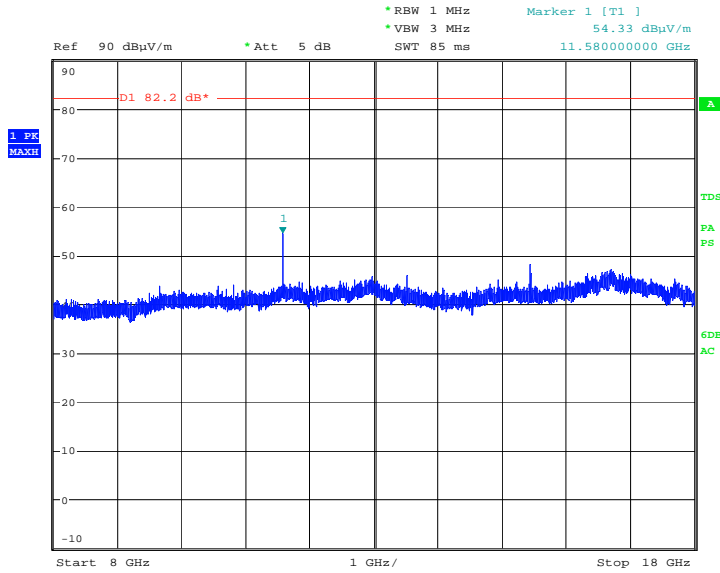

Date: 4.FEB.2018 10:40:07

Channel Position T – QPSK / Bandwidth 20.0MHz – 8GHz – 18GHz

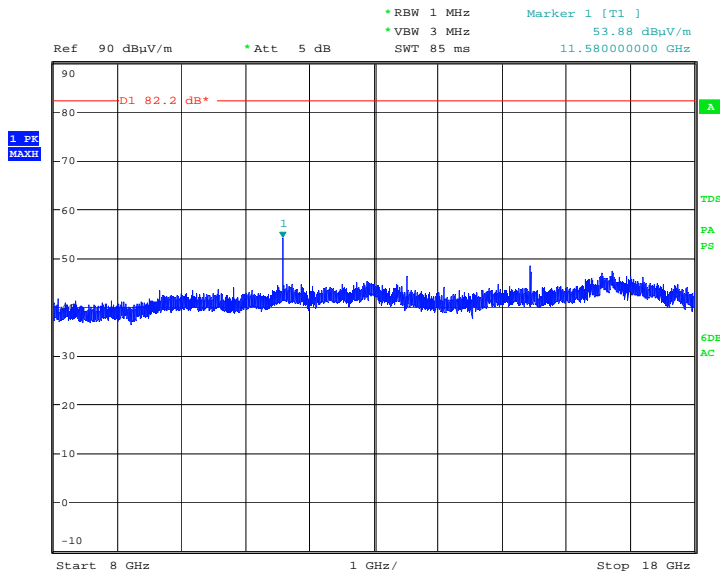

Date: 4.FEB.2018 10:45:33



Product Service

Channel Position B – QPSK / Bandwidth 20.0MHz – 18GHz – 20GHz

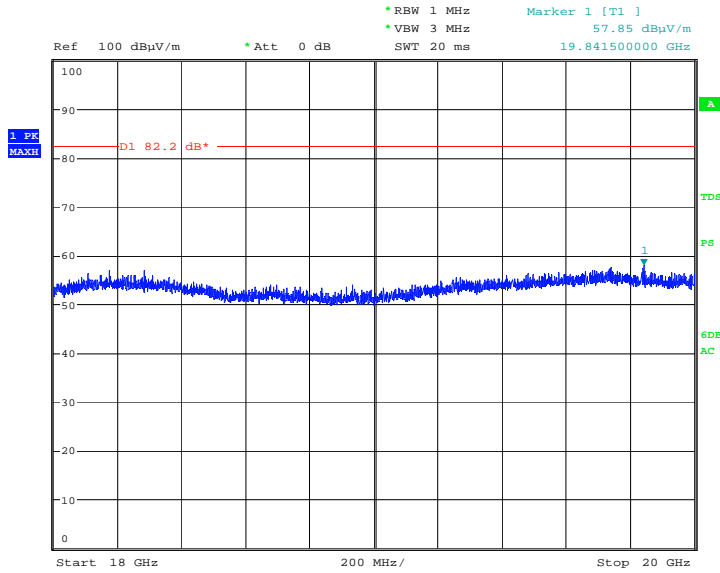

Date: 4.FEB.2018 08:20:34

Channel Position T – QPSK / Bandwidth 20.0MHz – 18GHz – 20GHz

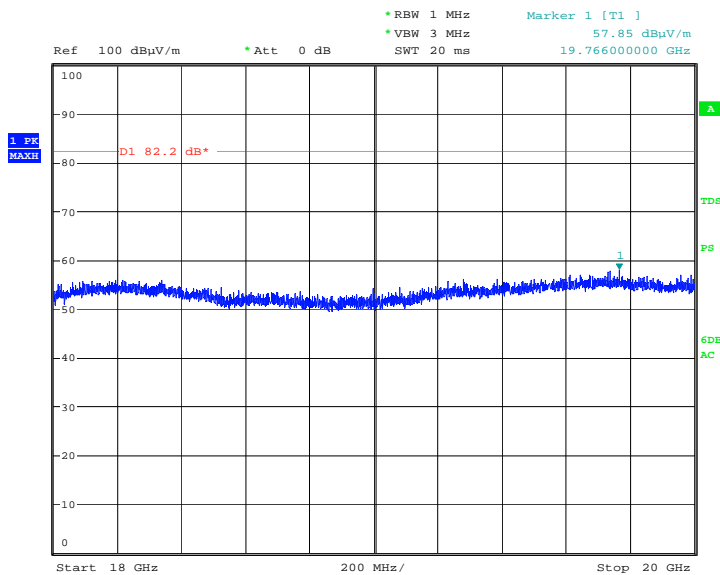

Date: 4.FEB.2018 08:22:44



Product Service

Configuration B

Maximum Output Power 49/47.8 dBm, LTE Bandwidth 0.2MHz

Channel Position B – QPSK / Bandwidth 0.2MHz – 30MHz – 1GHz

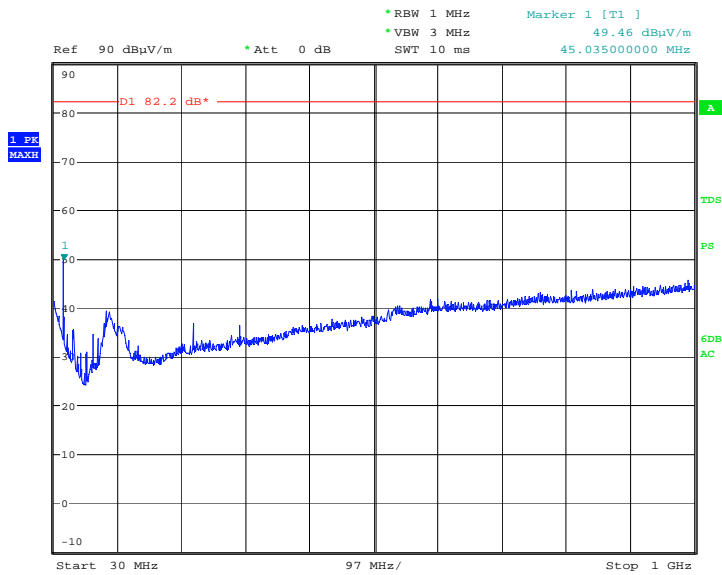

Date: 1.JAN.2003 00:50:29

Channel Position M – QPSK / Bandwidth 0.2MHz – 30MHz – 1GHz

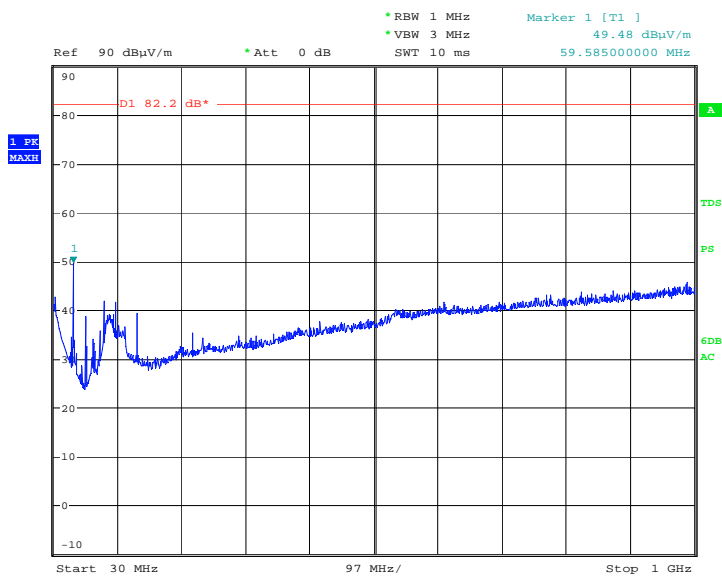

Date: 1.JAN.2003 00:46:27



Product Service

Channel Position T – QPSK / Bandwidth 0.2MHz – 30MHz – 1GHz

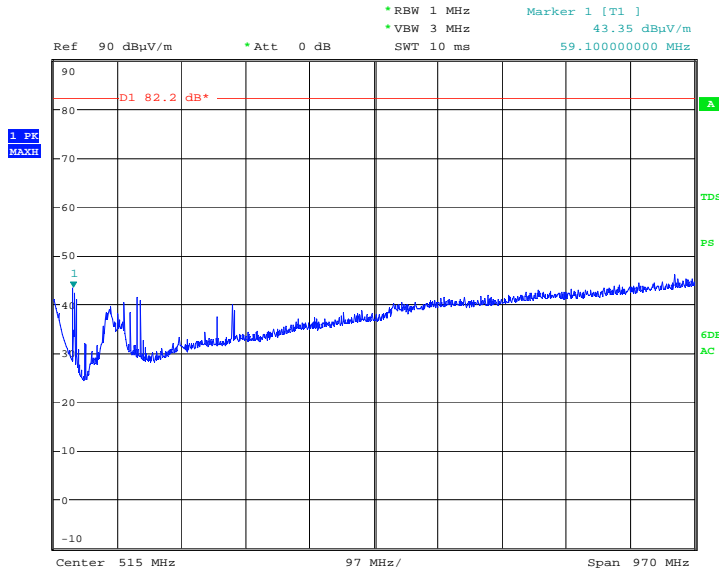

Date: 1.JAN.2003 00:36:52

Channel Position B – QPSK / Bandwidth 0.2MHz – 1GHz – 8GHz

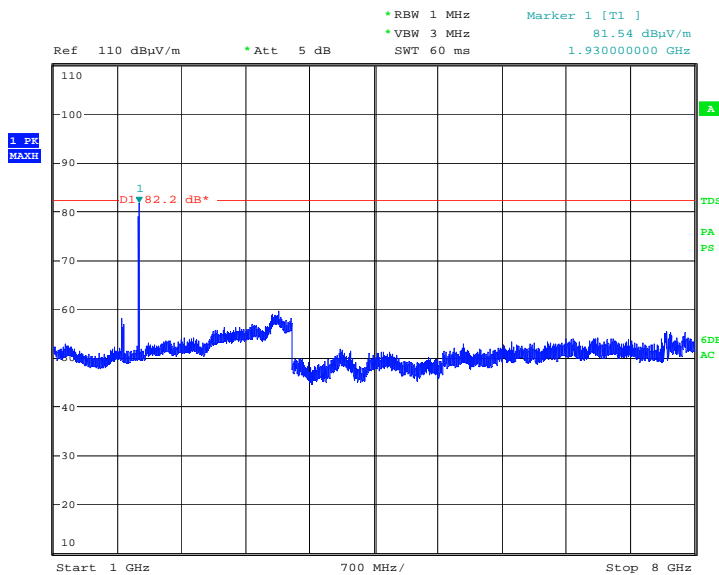

Date: 4.FEB.2018 11:41:16



Product Service

Channel Position M – QPSK / Bandwidth 0.2MHz – 1GHz – 8GHz

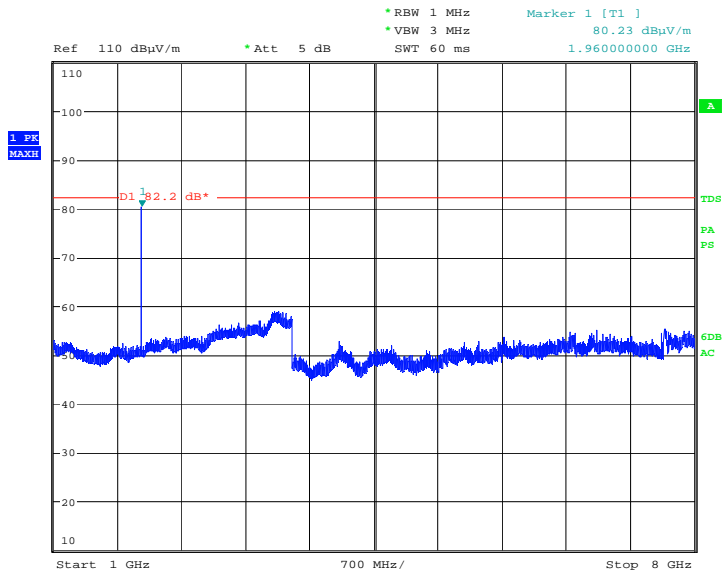

Date: 4.FEB.2018 11:25:50

Channel Position T – QPSK / Bandwidth 0.2MHz – 1GHz – 8GHz

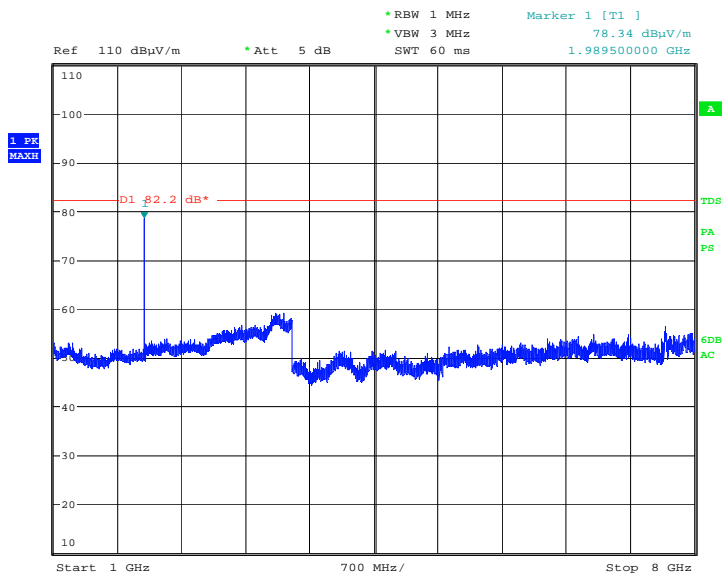

Date: 4.FEB.2018 11:20:22



Product Service

Channel Position B – QPSK / Bandwidth 0.2MHz – 8GHz – 18GHz

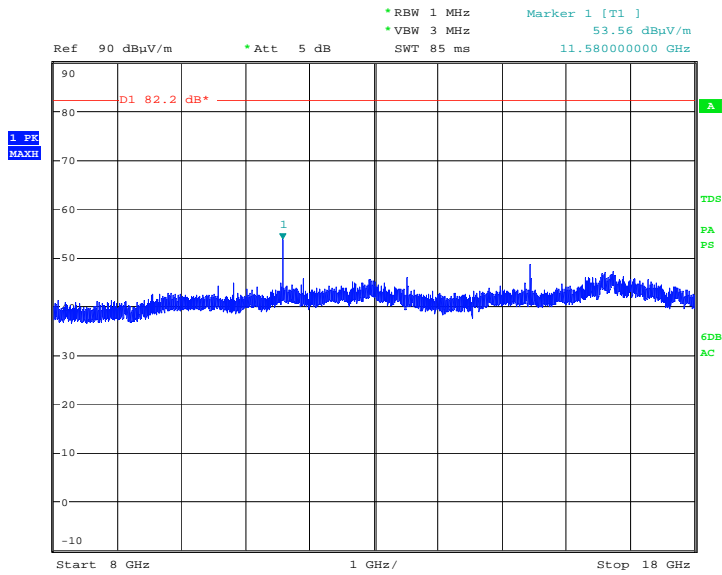

Date: 4.FEB.2018 10:53:02

Channel Position M – QPSK / Bandwidth 0.2MHz – 8GHz – 18GHz

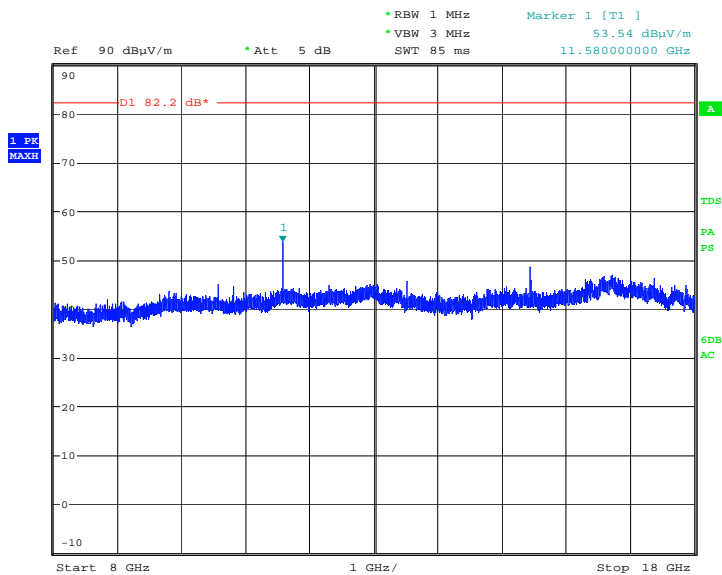

Date: 4.FEB.2018 10:58:20



Product Service

Channel Position T – QPSK / Bandwidth 0.2MHz – 8GHz – 18GHz

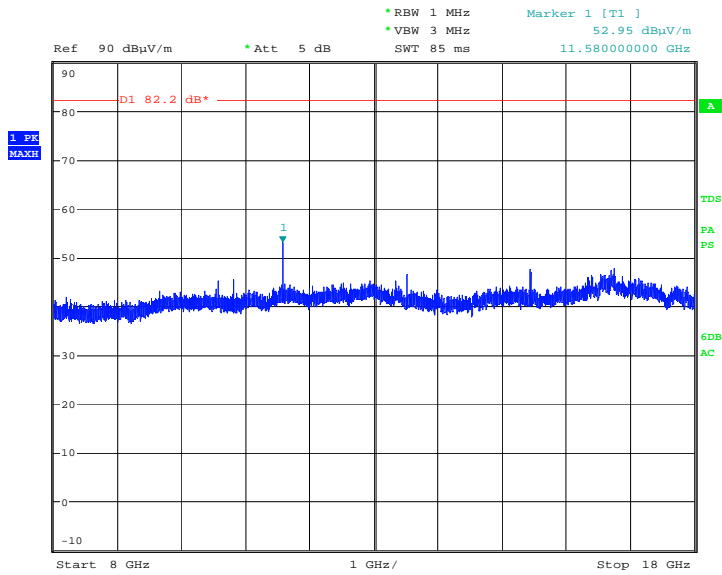

Date: 4.FEB.2018 11:02:15

Channel Position B – QPSK / Bandwidth 0.2MHz – 18GHz – 20GHz

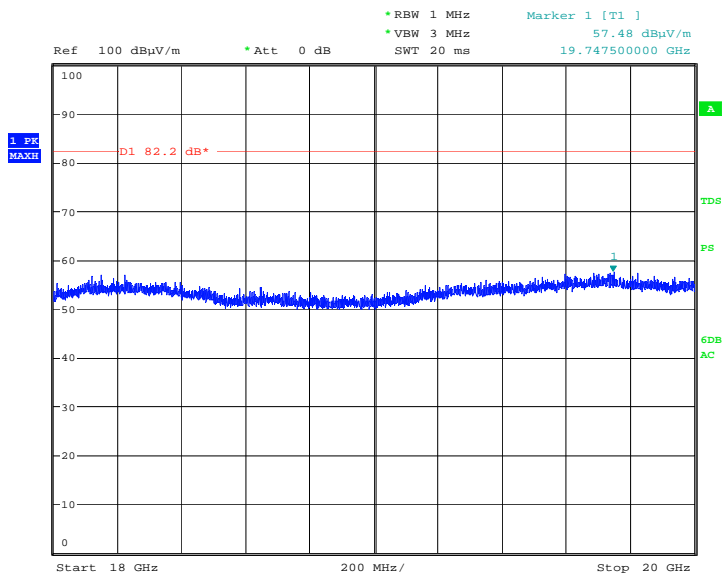

Date: 4.FEB.2018 08:29:59



Product Service

Channel Position M – QPSK / Bandwidth 0.2MHz – 18GHz – 20GHz

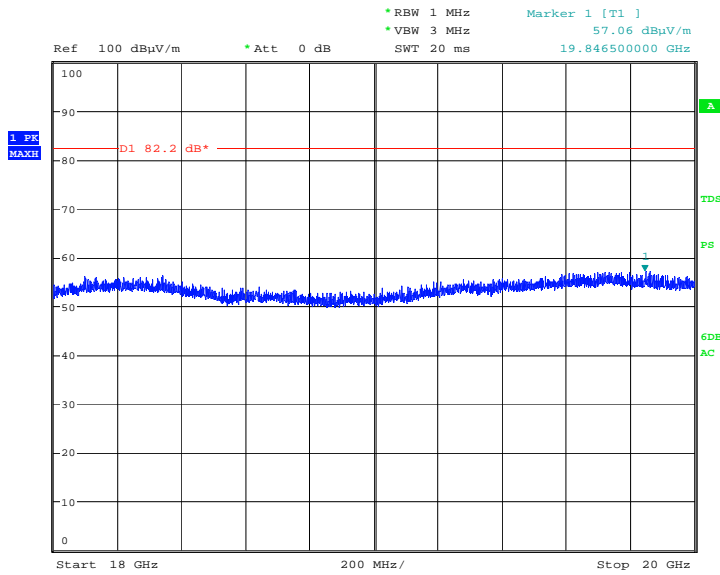

Date: 4.FEB.2018 08:27:05

Channel Position T – QPSK / Bandwidth 0.2MHz – 18GHz – 20GHz

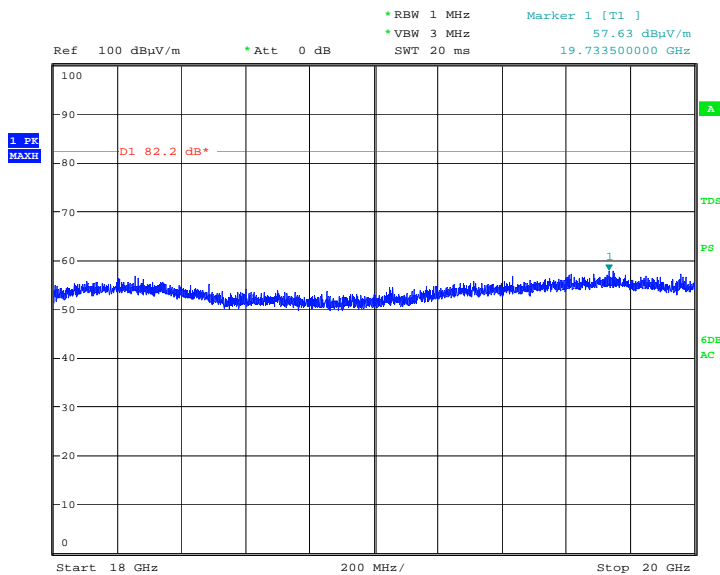

Date: 4.FEB.2018 08:32:44

Limit	-13dBm / 82.2 dBuV/m
-------	----------------------

The EUT does not exceed -13dBm / 82.2dBuV/m at the measured frequencies.



Product Service

SECTION 3

TEST EQUIPMENT USED



3.1 TEST EQUIPMENT USED

List of absolute measuring and other principal items of test equipment.

Instrument	Manufacturer	Type No.	TE No.	Calibration Period (months)	Calibration Due
Maximum Peak Output Power and Peak to Average Ratio - Conducted					
Spectrum Analyser	Keysight				
Network Analyser	Rohde&Schwarz	ZVA40	TE3548	12	02-Oct-2018
Calibration unit	Rohde&Schwarz	ZV-Z54	TE4368	12	19-Sep-2018
Power Meter	Rohde&Schwarz	NRP2	BAMS100151736	12	18-May-2018
Attenuator	Narda	769-10	TE33368	12	31-May-2018
Attenuator	Narda	769-20	TE3367	12	31-May-2018
Attenuator	Narda	769-30	TE3369	12	31-May-2018
RF Load	Weinschel	WA1425/12-DC	N/A	N/A	OP MON
Attenuator	Weinschel	56-3	T4390	N/A	OP MON
Power Supply	Agilent	N8738A	BAMS1001518021	N/A	OP MON
Hygromer	RS	TE3220	0427452	12	30-Aug-2018
Digital Volt Meter	White gold	WG022	TE00190	12	24-Nov-2018
Band Edge					
Spectrum Analyser	Keysight				
Network Analyser	Agilent	N5230A	MY45000737	12	16-May-2018
Power Meter	Rohde&Schwarz	NRP2	BAMS100151736	12	18-May-2018
Attenuator	Weinschel	68-34-20-11	QM935	N/A	OP MON
Attenuator	Weinschel	68-34-20-11	QC181	N/A	OP MON
Attenuator	Weinschel	WA49-40-33	A1067	N/A	OP MON
RF Load	Weinschel	WA1425/12-DC	N/A	N/A	OP MON
Attenuator	Weinschel	56-3	T4390	N/A	OP MON
Attenuator	Weinschel	56-10	T3515	N/A	OP MON
High Pass Filter	Wainwright	WHNX3.8/26.5G-6SS	8	N/A	OP MON
Power Supply	Agilent	N8738A	BAMS1001518021	N/A	OP MON
Hygromer	RS	TE4410	0421742	12	04-May-2018
Digital Volt Meter	Fluke	79 III	TE0411	12	02-Oct-2018
Transmitter Spurious Emissions					
Spectrum Analyser	Keysight				
Network Analyser	Agilent	N5230A	MY49430624	12	16-May-2018
Power Meter	Rohde&Schwarz	NRP2	BAMS100151736	12	18-May-2018
Attenuator	Weinschel	68-34-20-11	QM935	N/A	OP MON
Attenuator	Weinschel	68-34-20-11	QC181	N/A	OP MON
Attenuator	Weinschel	WA49-40-33	A1067	N/A	OP MON
RF Load	Weinschel	WA1425/12-DC	N/A	N/A	OP MON
Attenuator	Weinschel	56-3	T4390	N/A	OP MON
Attenuator	Weinschel	56-10	T3515	N/A	OP MON
High Pass Filter	Wainwright	WHNX3.8/26.5G-6SS	8	N/A	OP MON
Power Supply	Agilent	N8738A	BAMS1001518021	N/A	OP MON
Hygromer	RS	TE4410	0421742	12	04-May-2018



Product Service

Instrument	Manufacturer	Type No.	TE No.	Calibration Period (months)	Calibration Due
Radiated Spurious Emissions					
Antenna (Bilog)	Schaffner	CBL6143	287	24	18-Apr-2018
Filter (High Pass)	Lorch	SHP7-7000-SR	566	12	05-Apr-2018
Signal Generator (10MHz to 40GHz)	Rohde & Schwarz	SMR40	1002	12	20-Oct_2018
Antenna 18-40GHz (Double Ridge Guide)	Q-Par Angus Ltd	QSH 180K	1511	24	07-Dec-2018
Pre-Amplifier	Phase One	PS04-0086	1533	12	12-Jan-2019
18GHz - 40GHz Pre-Amplifier	Phase One	PSO4-0087	1534	12	27-Feb-2018

N/A – Not Applicable

O/P Mon – Output Monitored with Calibrated Equipment



Product Service

3.2 MEASUREMENT UNCERTAINTY

For a 95% confidence level, the measurement uncertainties for defined systems are:-

Test Discipline	Frequency / Parameter	MU
Conducted Maximum Peak Output Power	30 MHz to 20 GHz Amplitude	± 0.1 dB
Conducted Emissions	30 MHz to 20 GHz Amplitude	± 2.3 dB
Frequency Stability	30 MHz to 2 GHz	± 5.0 Hz
Occupied Bandwidth	Up to 20 MHz Bandwidth	± 1.1 Hz
Band Edge	30 MHz to 20 GHz Amplitude	± 2.3 dB
Radiated Emissions, Bilog Antenna, AOATS	30MHz to 1GHz Amplitude	5.1dB*
Radiated Emissions, Horn Antenna, AOATS	1GHz to 40GHz Amplitude	6.3dB*
Worst case error for both Time and Frequency measurement 12 parts in 10 ⁶		



Product Service

SECTION 5

ACCREDITATION, DISCLAIMERS AND COPYRIGHT



Product Service

4.1 ACCREDITATION, DISCLAIMERS AND COPYRIGHT



This report relates only to the actual item/items tested.

Our UKAS Accreditation does not cover opinions and interpretations and any expressed are outside the scope of our UKAS Accreditation.

Results of tests not covered by our UKAS Accreditation Schedule are marked NUA (Not UKAS Accredited).

© 2018 TÜV SÜD Product Service



Product Service

ANNEX A

MODULE LIST



Product Service

Configuration A & B			
Product	Product No	R-State	Serial No
CT 10	LPC 10248B7/1	R1C	TO1F410050
RUS 01 B2	KRC 118 66/2	R1G	CF83604455
Software Version:	xrus_app-CXP9013268_6-R66AM.xif (based on CXP9013268/6 R66BM)		