

Handled by, department
Reinhold Reul
Electronics
+46 (0)10 516 5584, reinhold.reul@sp.se

Ericsson AB
Mats Falk
PDU Radio Base Station
Lindholmospiren 11
417 56 Göteborg

Radio measurements on RRUW 02 B5 WCDMA 850 MHz radio equipment with FCC ID: TA8AKRC11846-2 and IC: 287AB-AW118462

(9 appendices)

Test object

RRUW 02 B5, KRC 118 46/2 Rev. R1A, S/N C822419132

Appendix 1 provides information about the test object and the test set-up.
Appendix 9 provides external photos of the test object.

Summary

Standard	Compliant	Appendix
FCC CFR 47 / IC RSS-132 Issue 2		
2.1046 / RSS-132 4.4 RF power output	Yes	2
2.1049 / RSS-Gen 4.6.1 Occupied bandwidth	Yes	3
2.1051 / RSS-132 4.5 Band edge	Yes	4
2.1051 / RSS-132 4.5 Spurious emission at antenna terminals	Yes	5
2.1053 / RSS-132 4.5 Field strength of spurious radiation	Yes	6
2.1055 / RSS-132 4.3 Frequency stability	Yes	7
FCC CRF 47 / Industry Canada RSS-132 Issue 2		
15.111 / RSS-132 4.6 Receiver spurious emissions	Yes	8

Note: Above RSS-132 items are given as cross-reference only. Measurements were performed according to ANSI procedures referenced by FCC and covered by SP's accreditation.

SP Technical Research Institute of Sweden Electronics - EMC

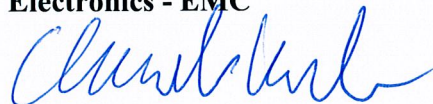

Christer Karlsson
Technical Manager



Reinhold Reul
Technical Officer

SP Technical Research Institute of Sweden

Postal address

SP
Box 857
SE-501 15 Borås
SWEDEN

Office location

Västeråsen
Brinellgatan 4
Borås

Phone / Fax / E-mail

+46 105 16 50 00
+46 33 13 55 02
info@sp.se

Laboratories are accredited by the Swedish Board for Accreditation and Conformity Assessment (SWEDAC) under the terms of Swedish legislation. This report may not be reproduced other than in full, except with the prior written approval of the issuing laboratory.



REPORT

FCC ID: TA8AKRC11846-2
IC: 287AB-AW118462

Table of contents

Description of the test object	Appendix 1
Operation mode during measurements	Appendix 1
Test setups	Appendix 1
Purpose of test	Appendix 1
RF power output	Appendix 2
Occupied bandwidth	Appendix 3
Band edge	Appendix 4
Spurious emission at antenna terminals	Appendix 5
Field strength of spurious radiation	Appendix 6
Frequency stability	Appendix 7
Receiver spurious emissions	Appendix 8
External photos	Appendix 9

FCC ID: TA8AKRC11846-2
IC: 287AB-AW118462

Appendix 1

Description – Test object

Equipment: WCDMA radio equipment (RRUW) 850 MHz single and multi carrier.

Frequency range: TX: 871.4 – 891.6 MHz
RX: 826.4 – 846.6 MHz

Modulations: QPSK, 16QAM and 64QAM

Maximum output power: Single carrier: 1x 47.8 dBm (1x 60W)
Multi carrier: 2x 44.8 dBm (2x 30W)

Channel bandwidth: 4.2 to 5 MHz (configurable in steps of 100/200 kHz)

Channel spacing: 4.4 to 5 MHz (configurable in steps of 100/200 kHz)

Nominal power voltage: -48 VDC

Tested channels

UARFCN	Frequency
4357	871.4 MHz
4382	876.4 MHz
4407	881.4 MHz
4408	881.6 MHz
4433	886.6 MHz
4458	891.6 MHz

Operation mode during measurements

Measurements were performed with the test object transmitting the Test models which are defined in 3GPP TS 25.141. Test model 1 (TM1) uses the QPSK modulation only, Test model 5 (TM5) includes the 16QAM modulation and Test model 6 (TM6) includes the 64QAM modulation.

The settings below were found to be representative for all traffic scenarios when several settings with the different modulations and channel bandwidths were tested to find the worst case setting. These settings were used for all measurements if not otherwise noted.

Single carrier TM1: 64 DPCH:s at 30 ksps (SF=128)
Multi carrier TM1: 32 DPCH:s at 30 ksps (SF=128) in each carrier
Channel bandwidth 5 MHz

Conducted measurements

The test object was powered with -48 VDC. All RF conducted measurements were performed with the test object configured for maximum transmit power. All TX measurements were done at the Ant 1 connector and the RX measurements were done on the Ant 2 connector.

FCC ID: TA8AKRC11846-2
IC: 287AB-AW118462

Appendix 1

Radiated measurements

The test object was powered with -48 VDC. All measurements were performed with the test object configured for maximum transmit power. The configuration represents worst case for radiated spurious emission measurements.

The RF output power port was via a RF attenuator connected to functional test equipment for supervision.

The RRUW unit was allocated to the following UARFCN:

Single Carrier:

Downlink	4357 (871.4 MHz)	4408 (881.6 MHz)	4458 (891.6 MHz)
Uplink	4132 (826.4 MHz)	4183 (836.6 MHz)	4233 (846.6 MHz)

Multi Carrier:

Cell	1	2	1	2
Downlink	4357 (871.4 MHz)	4407 (881.4 MHz)	4408 (881.6 MHz)	4458 (891.6 MHz)
Uplink	4132 (826.4 MHz)	4182 (836.4 MHz)	4183 (836.6 MHz)	4233 (846.6 MHz)

Purpose of test

The purpose of the tests is to verify compliance to the performance characteristics specified in applicable items of FCC CFR 47 and Industry Canada RSS-132.

References

Measurements were done according to relevant parts of the following standards:

ANSI 63.4-2003
ANSI/TIA/EIA-603-B-2002
3GPP TS 25.141
RSS-Gen Issue 2
RSS-132 Issue 2

FCC ID: TA8AKRC11846-2
IC: 287AB-AW118462

Appendix 1

Measurement equipment

Measurement equipment	Calibration Due	SP number
Test site Tesla	2010-10	503 881
R&S FSIQ 40	2009-08	503 738
R&S FSQ 40	2009-08	504 143
R&S ESI 26	2009-07	503 292
High pass filter	2010-06	503 739
RF attenuator	2009-06	504 159
RF step attenuator	2009-06	503 096
Boonton RF Peak power meter/analyzer	2009-08	503 144
Boonton Power sensor 56518-S/4	2010-02	503 146
Chase Bilog antenna CBL 6111A	2011-11	502 181
EMCO Horn Antenna 3115	2011-01	502 175
MITEQ Low Noise Amplifier	2009-06	503 285
Climate chamber 2	2009-12	501 031
Multimeter Fluke 87	2010-01	502 190
Testo 615, Temperature and humidity meter	2009-11	503 505

Reservation

The test results in this report apply only to the particular test object as declared in the report.

Delivery of test object

The test object was delivered: 2009-05-08.

Test engineers

Andreas Johnson, Jörgen Wassholm and Reinhold Reul

Test participants

Christer Hjorth and Ove Nilsson, Ericsson AB

FCC ID: TA8AKRC11846-2
IC: 287AB-AW118462

Appendix 1

Test set-up conducted measurements TX

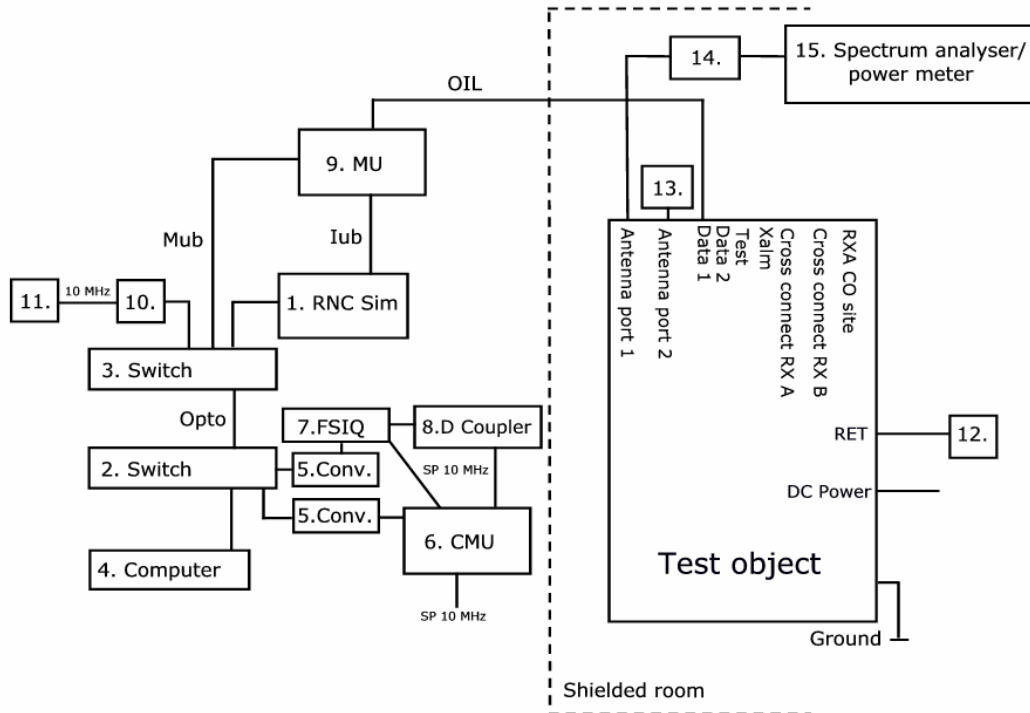

Test object

RRUW 02 B5, KRC 118 46/2 Rev R1A, S/N C822419132
with software CXP 901 3008 Rev R9CG04
(FCC ID: TA8AKRC11846-2 / IC: 287AB-AW118462)

Functional test equipment

1. RNC Sim 4780 DA, mini-SIM#65, s/n 0210 rev. BAMS 1000544673
2. Fast ethernet switch, Netgear FS726
3. Fast ethernet switch, Netgear FS726
4. Computer Sunblade Ultra 45 BAMS 1000655789
5. Ethernet/GPIB converter, National Instrument
6. CMU 300, R & S, BAMS 1000452891
7. Spectrum analyzer, R & S, FSIQ 26, BAMS 1000452890
8. Directional coupler
9. Main Unit: RBS 3418, BFE 401 1019, Software CXP 901 3008, rev. R9CG04
10. NTP-server, Symmetricom, BAMS 1000562217
11. Symmetricon model 8040 BAMS 1000645314
12. RET – Remote Electrical Tilt unit
13. Terminator
14. Attenuator SP 504 159
15. SP test equipment

FCC ID: TA8AKRC11846-2
 IC: 287AB-AW118462

Appendix 1

Test set-up conducted measurements RX

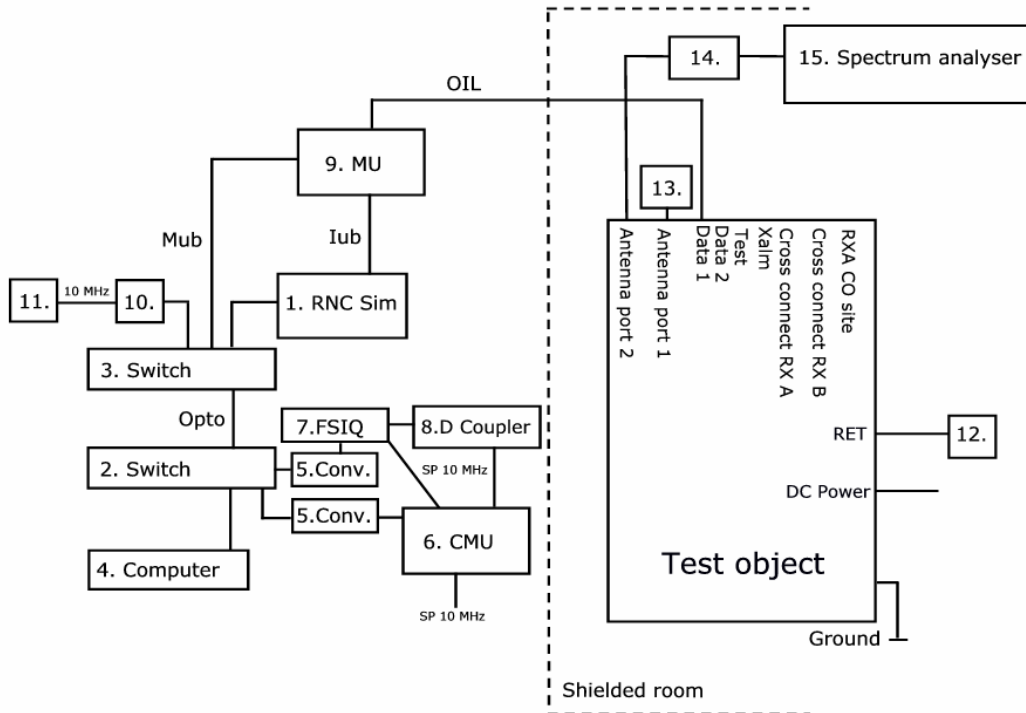

Test object

RRUW 02 B5, KRC 118 46/2 Rev R1A, S/N C822419132
 with software CXP 901 3008 Rev R9CG04
 (FCC ID: TA8AKRC11846-2 / IC: 287AB-AW118462)

Functional test equipment

1. RNC Sim 4780 DA, mini-SIM#65, s/n 0210 rev. BAMS 1000544673
2. Fast ethernet switch, Netgear FS726
3. Fast ethernet switch, Netgear FS726
4. Computer Sunblade Ultra 45 BAMS 1000655789
5. Ethernet/GPIB converter, National Instrument
6. CMU 300, R & S, BAMS 1000452891
7. Spectrum analyzer, R & S, FSIQ 26, BAMS 1000452890
8. Directional coupler
9. Main Unit: RBS 3418, BFE 401 1019, Software CXP 901 3008, rev. R9CG04
10. NTP-server, Symmetricom, BAMS 1000562217
11. Symmetricom model 8040 BAMS 1000645314
12. RET – Remote Electrical Tilt unit
13. Attenuator SP 504 159 and 50 ohm terminator.
14. Attenuator SP 503 096
15. SP test equipment

FCC ID: TA8AKRC11846-2
IC: 287AB-AW118462

Appendix 1

Test set-up radiated measurements

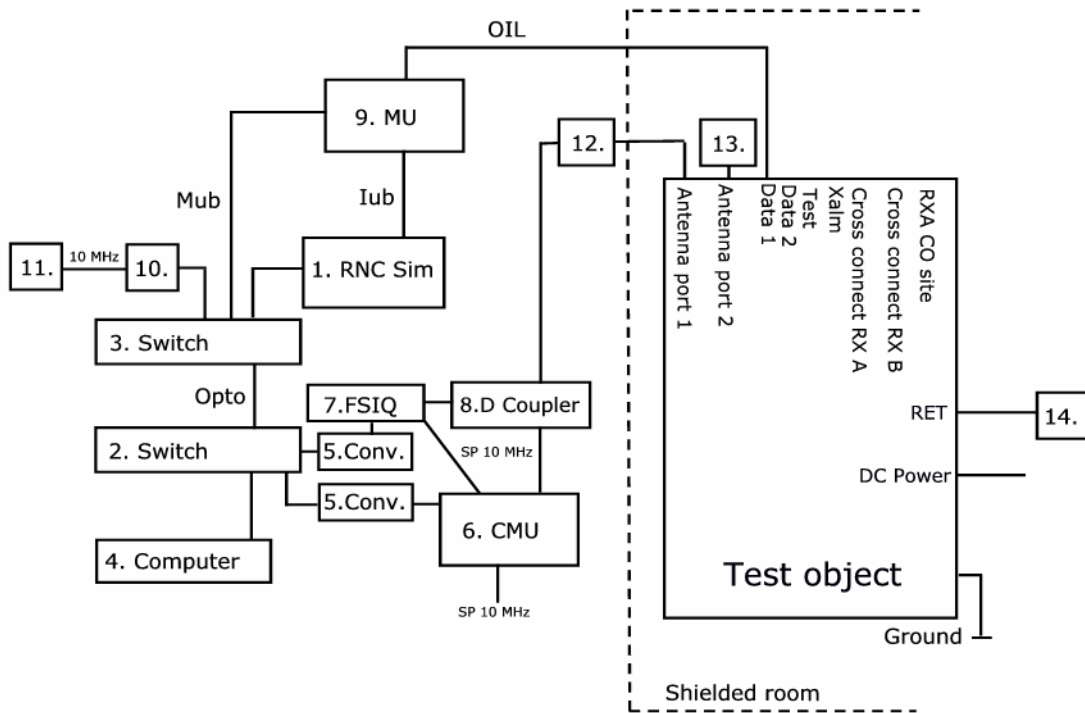

Test object

RRUW 02 B5, KRC 118 46/2 Rev R1A, S/N C822419132
with software CXP 901 3008 Rev R9CG04
(FCC ID: TA8AKRC11846-2 / IC: 287AB-AW118462)

Functional test equipment

1. RNC Sim 4780 DA, mini-SIM#65, s/n 0210 rev. BAMS 1000544673
2. Fast ethernet switch, Netgear FS726
3. Fast ethernet switch, Netgear FS726
4. Computer Sunblade Ultra 45 BAMS 1000655789
5. Ethernet/GPIB converter, National Instrument
6. CMU 300, R & S, BAMS 1000452891
7. Spectrum analyzer, R & S, FSIQ 26, BAMS 1000452890
8. Directional coupler
9. Main Unit: RBS 3418, BFE 401 1019, Software CXP 901 3008, rev. R9CG04
10. NTP-server, Symmetricom, BAMS 1000562217
11. Symmetricom model 8040 BAMS 1000645314
12. Attenuator, Weinschel model 48-30-33 s/n BH8672
13. Terminated in 50 ohm
14. RET – Remote Electrical Tilt unit



REPORT

FCC ID: TA8AKRC11846-2
IC: 287AB-AW118462

Appendix 1

Interfaces:	Type of port:
Power configuration: -48 VDC	DC Power
Antenna port 1, 7/16 connector, female	Antenna
Antenna port 2, terminated	Antenna
Test, No cable attached	Test purposes
Xalm, Not supported	Signal
Cross connect RX A, Not supported	Signal
Cross connect RX B, Not supported	Signal
RXA CO-site, Not supported	Signal
RET- cable, Shielded multi-wire connected to Remote electrical tilt unit	Signal
Data 1: Optical Interface Link, Single mode opto fibre	Signal
Data 2: Not supported	Signal



FCC ID: TA8AKRC11846-2
IC: 287AB-AW118462

Appendix 2

RF power output measurements according to 47 CFR 2.1046/ RSS-132 4.4

Date	Temperature	Humidity
2009-05-19	22 °C ± 3 °C	40 % ± 5 %
2009-05-20	22 °C ± 3 °C	36 % ± 5 %
2009-05-25	22 °C ± 3 °C	36 % ± 5 %

Test set-up and procedure

The output was connected to a peak power analyzer with the CDF mode activated.

Measurement equipment	SP number
Boonton RF Peak power meter/analyzer	503 144
Boonton Power sensor 56518-S/4	503 146
Multimeter Fluke 87	502 190
Testo 615, Temperature and humidity meter	503 505

Measurement uncertainty: 0.5 dB

Results

Single carrier: Rated output power level at Ant 1 connector (maximum): 1x 47.8 dBm

Transmitter power (dBm / dB) RMS / PAR		
Frequency 871.4 MHz	Frequency 881.6 MHz	Frequency 891.6 MHz
48.0 / 6.4	47.8 / 6.4	47.8 / 6.8

Multi carrier: Rated output power level at Ant 1 connector (maximum): 2x 44.8 dBm

Transmitter combined power (dBm / dB) RMS / PAR	
Frequencies 871.4 MHz 881.4 MHz	Frequencies 881.6 MHz 891.6 MHz
47.5 / 6.4	47.5 / 6.5

Limit

According to CFR 47/ RSS there are no conducted limits at the antenna connector.

CFR § 22.913/ SRSP-503 5.1: The effective radiated power (ERP) of base transmitters and cellular repeaters must not exceed 500 Watts (57 dBm).

RSS-132: The transmitter output power shall not exceed the limits given in SRSP-503

Complies?	Yes
-----------	-----



FCC ID: TA8AKRC11846-2
IC: 287AB-AW118462

Appendix 3

Occupied bandwidth measurements according to 47 CFR 2.1049/ RSS-Gen 4.6.1

Date	Temperature	Humidity
2009-05-19	22 °C ± 3 °C	40 % ± 5 %
2009-05-20	22 °C ± 3 °C	36 % ± 5 %

Test set-up and procedure

The measurements were made as defined in §2.1049. The output was connected to a spectrum analyzer. The spectrum analyzer was connected to an external 10 MHz reference standard during the measurements.

Measurement equipment	SP number
R&S FSIQ	503 738
Testo 615, Temperature and humidity meter	503 505

Measurement uncertainty: 3.7 dB

Results

The results are shown in appendix 3.1

Channel Bandwidth 5.0 MHz

	Frequency	OBW
Diagram 1	871.4 MHz	4.18 MHz
Diagram 2	881.6 MHz	4.18 MHz
Diagram 3	891.6 MHz	4.18 MHz

Channel Bandwidth 4.2 MHz

	Frequency	OBW
Diagram 4	871.4 MHz	3.87 MHz
Diagram 5	881.6 MHz	3.86 MHz
Diagram 6	891.6 MHz	3.85 MHz



FCC ID: TA8AKRC11846-2
IC: 287AB-AW118462

Appendix 3.1

Diagram 1

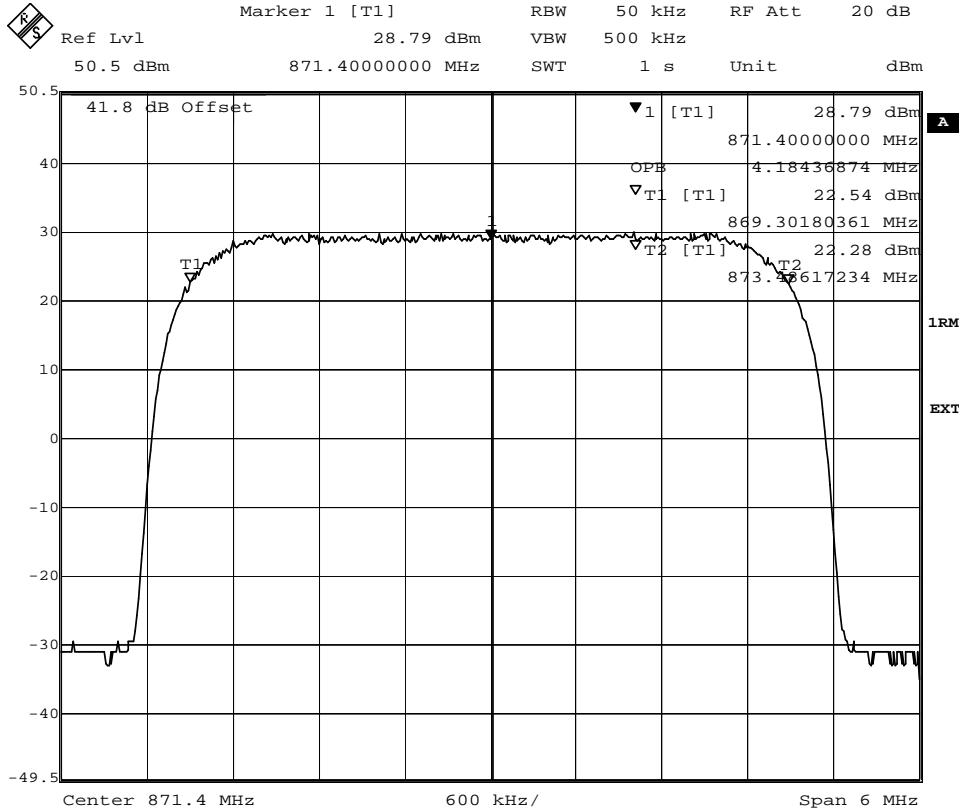

Date: 19.MAY.2009 15:29:00

Diagram 2

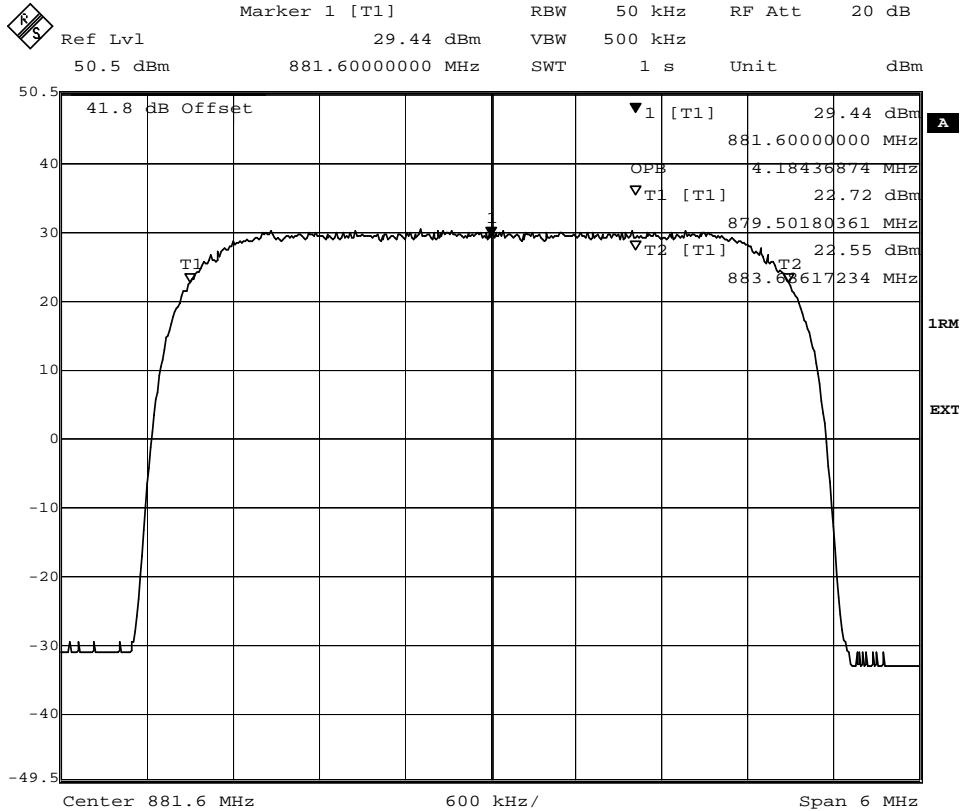

Date: 20.MAY.2009 12:09:55



FCC ID: TA8AKRC11846-2
IC: 287AB-AW118462

Appendix 3.1

Diagram 3

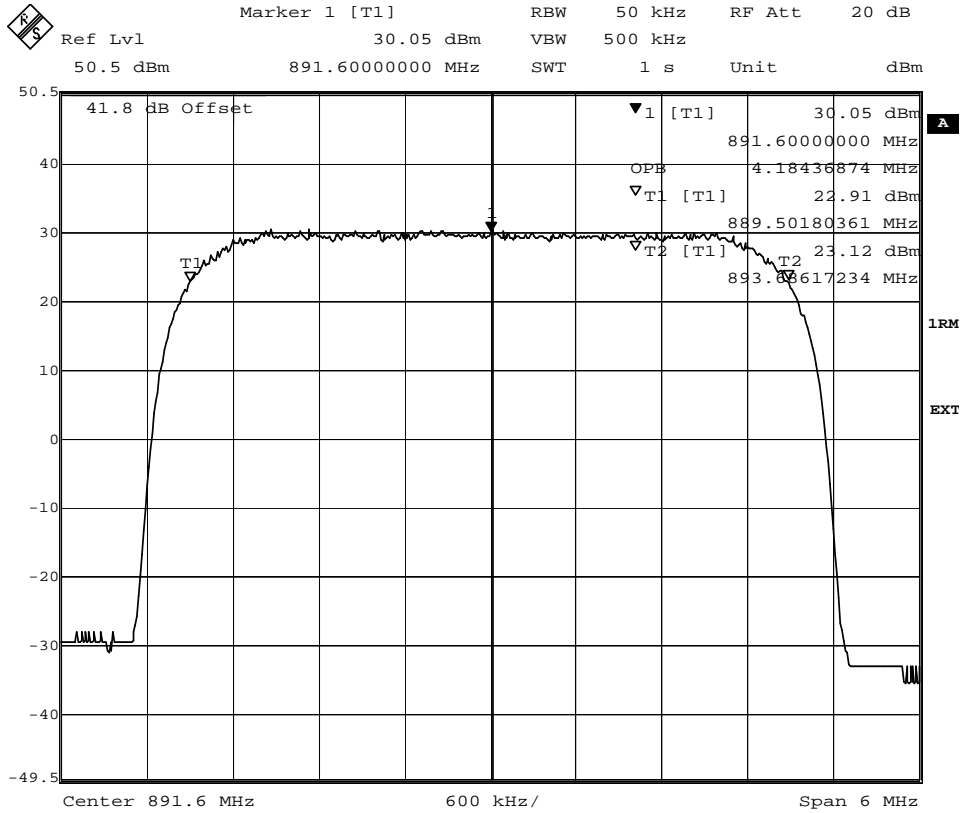

Date: 20.MAY.2009 12:44:12

Diagram 4

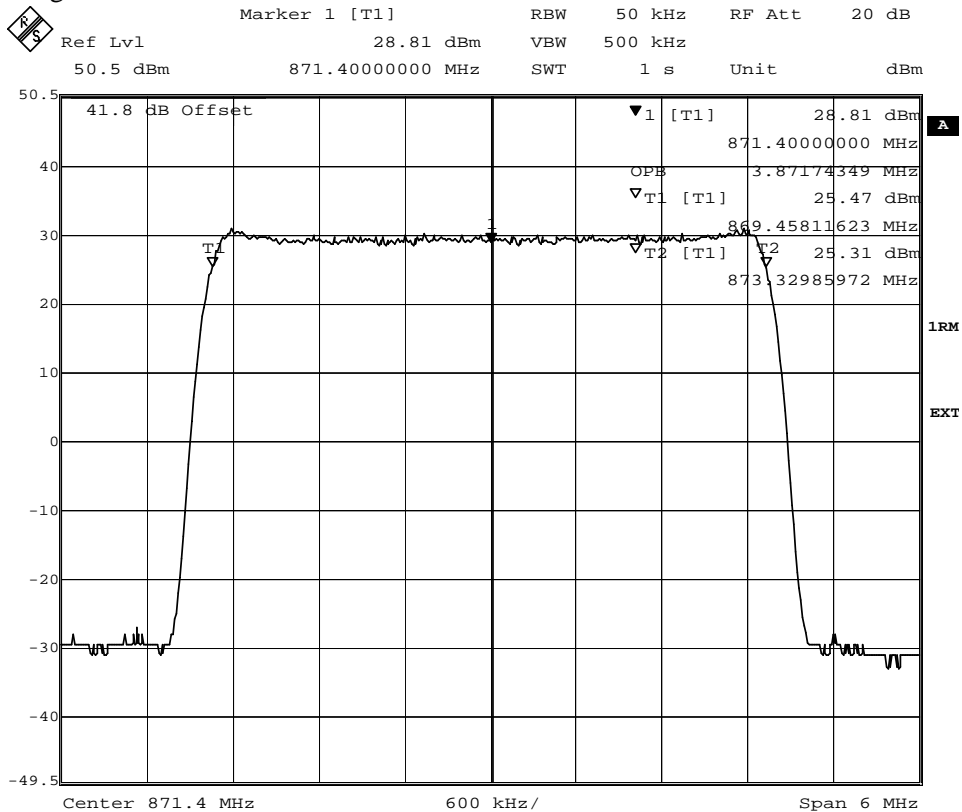

Date: 20.MAY.2009 09:55:30



FCC ID: TA8AKRC11846-2
IC: 287AB-AW118462

Appendix 3.1

Diagram 5

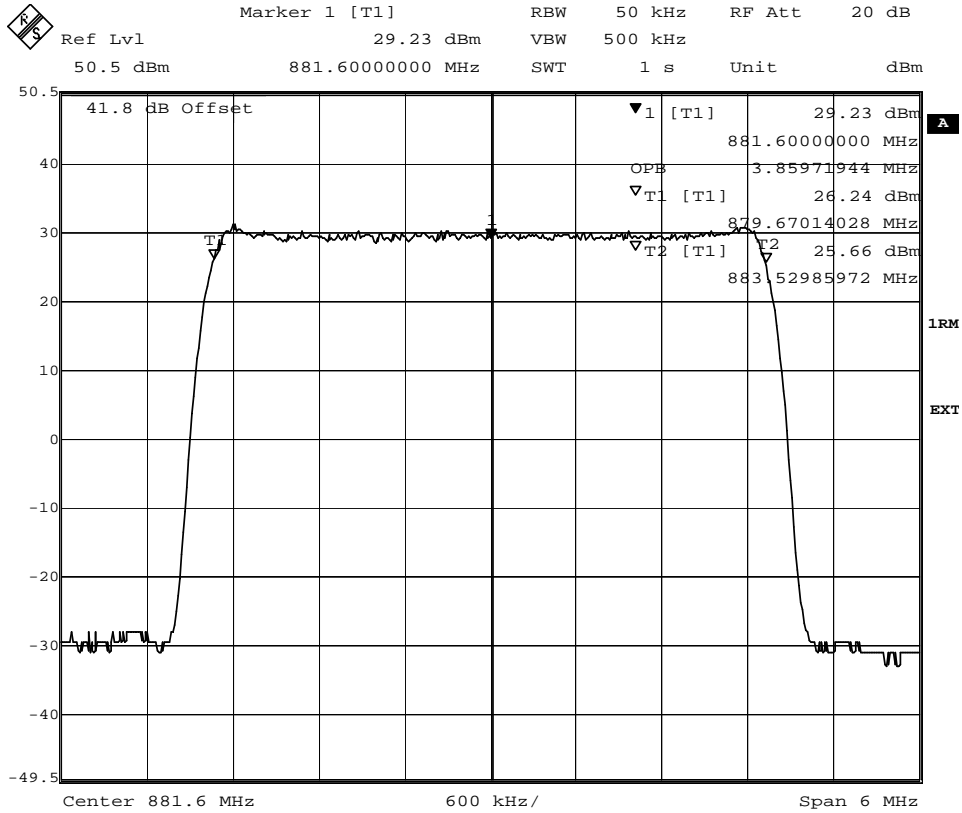

Date: 20.MAY.2009 10:06:55

Diagram 6

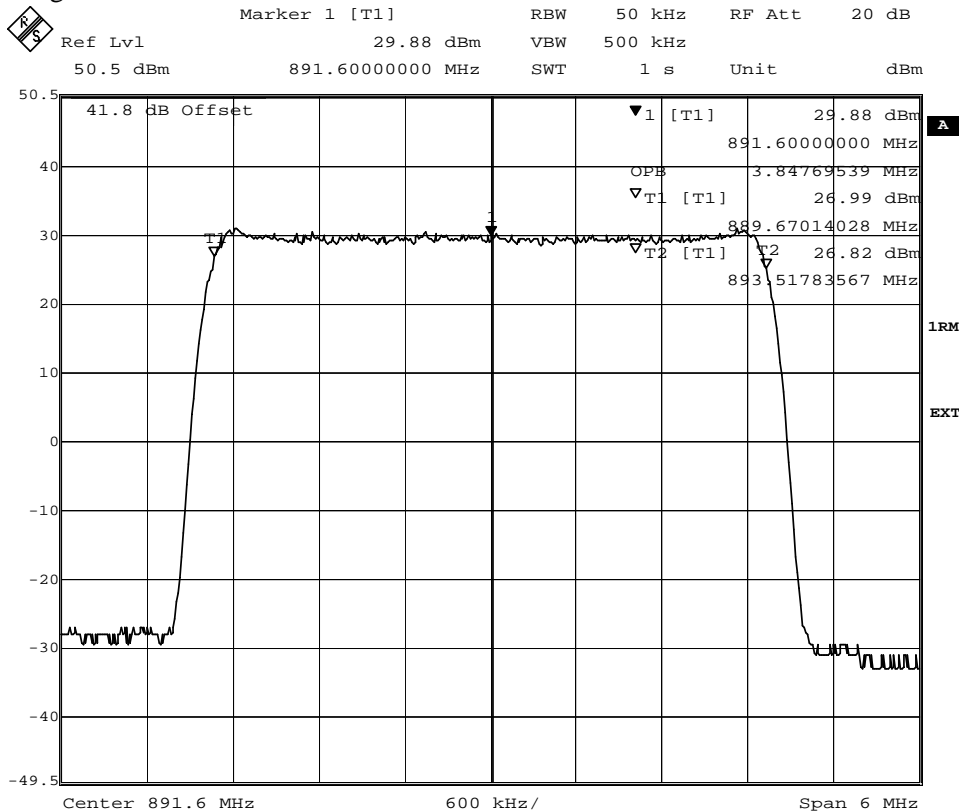

Date: 20.MAY.2009 13:17:33



FCC ID: TA8AKRC11846-2
IC: 287AB-AW118462

Appendix 4

Band edge measurements according to 47 CFR 2.1051/ RSS-132 4.5

Date	Temperature	Humidity
2009-05-19	22 °C ± 3 °C	40 % ± 5 %
2009-05-20	22 °C ± 3 °C	36 % ± 5 %
2009-05-25	22 °C ± 3 °C	36 % ± 5 %

Test set-up and procedure

The measurements were made as defined in §22.917. The output was connected to a spectrum analyzer with the RMS detector activated. The spectrum analyzer was connected to an external 10 MHz reference standard during the measurements. A resolution bandwidth of 30 kHz was used up to 3.25 MHz away from the band edges. 30 kHz is <1% of the Emission BW (4.25 MHz between the 26 dB points for 5 MHz nominal BW setting). To compensate for the reduced measurement bandwidth, the limit was adjusted with 1.5 dB to -14.5 dBm up to 1 MHz away from the band edges and with 15.2 dB to -28.2 dBm from 1 MHz to 3.25 MHz away from the band edges.

Measurement equipment	SP number
R&S FSIQ	503 738
Testo 615, Temperature and humidity meter	503 505

Measurement uncertainty: 3.7 dB

Results

The results are shown in appendix 4.1

Single carrier:

Diagram 1: 871.4 MHz

Diagram 2: 891.6 MHz

Multi carrier:

Diagram 3: 871.4+876.4 MHz

Diagram 4: 891.6+886.6 MHz

Limits

The power of any emission outside the frequency band shall be attenuated below the transmitter power (P) by at least $43 + 10 \log P$ dB.

Complies?	Yes
-----------	-----



FCC ID: TA8AKRC11846-2
IC: 287AB-AW118462

Appendix 4.1

Diagram 1

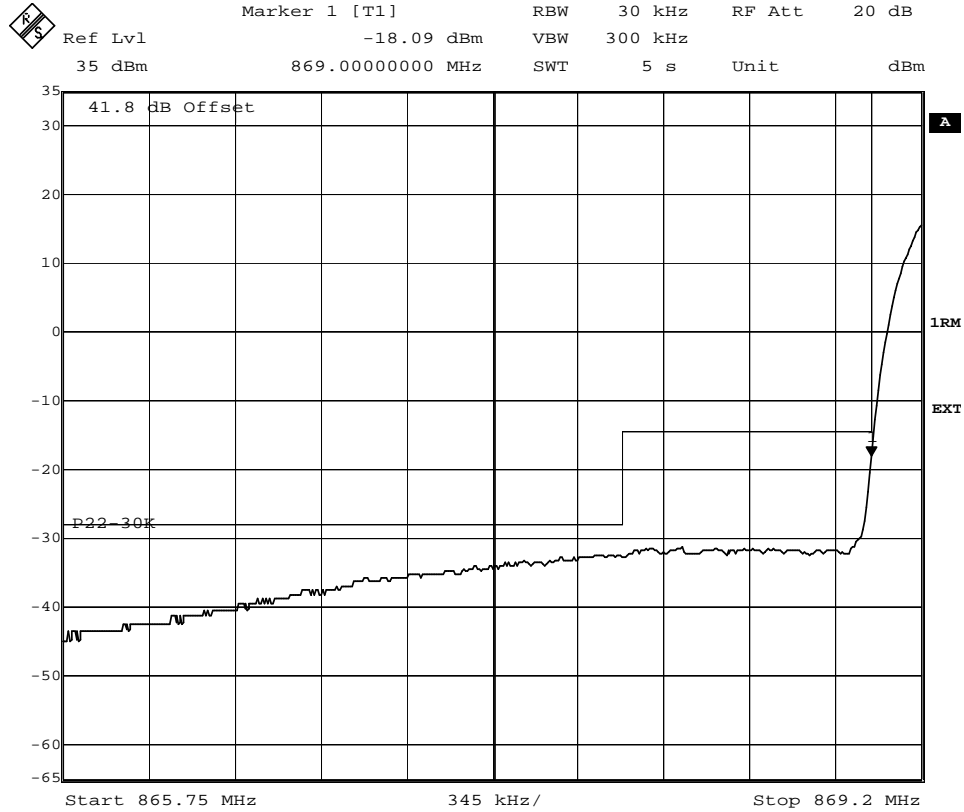

Date: 19.MAY.2009 15:36:22

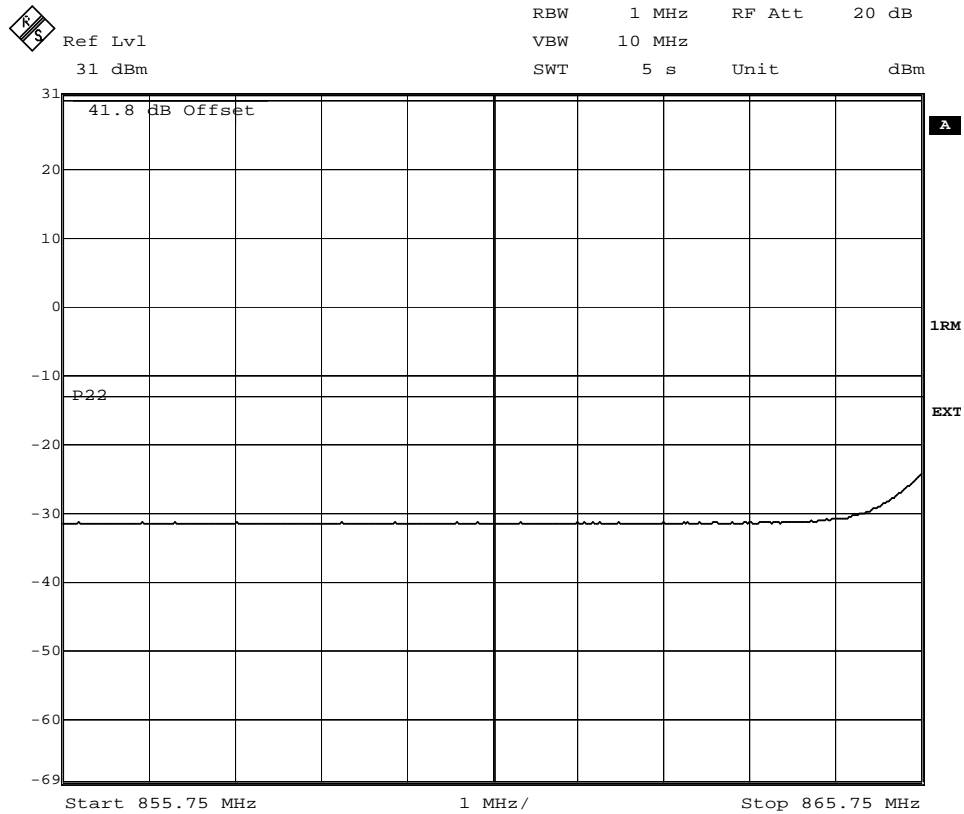

Date: 19.MAY.2009 15:38:10



FCC ID: TA8AKRC11846-2
IC: 287AB-AW118462

Appendix 4.1

Diagram 2

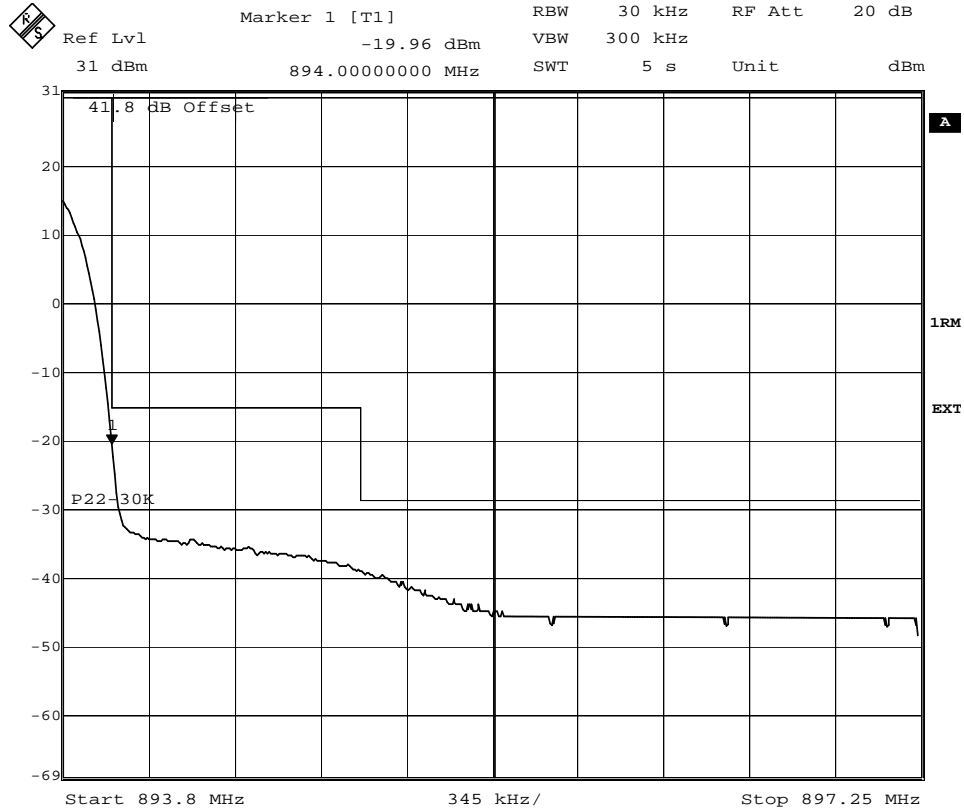

Date: 20.MAY.2009 12:48:34

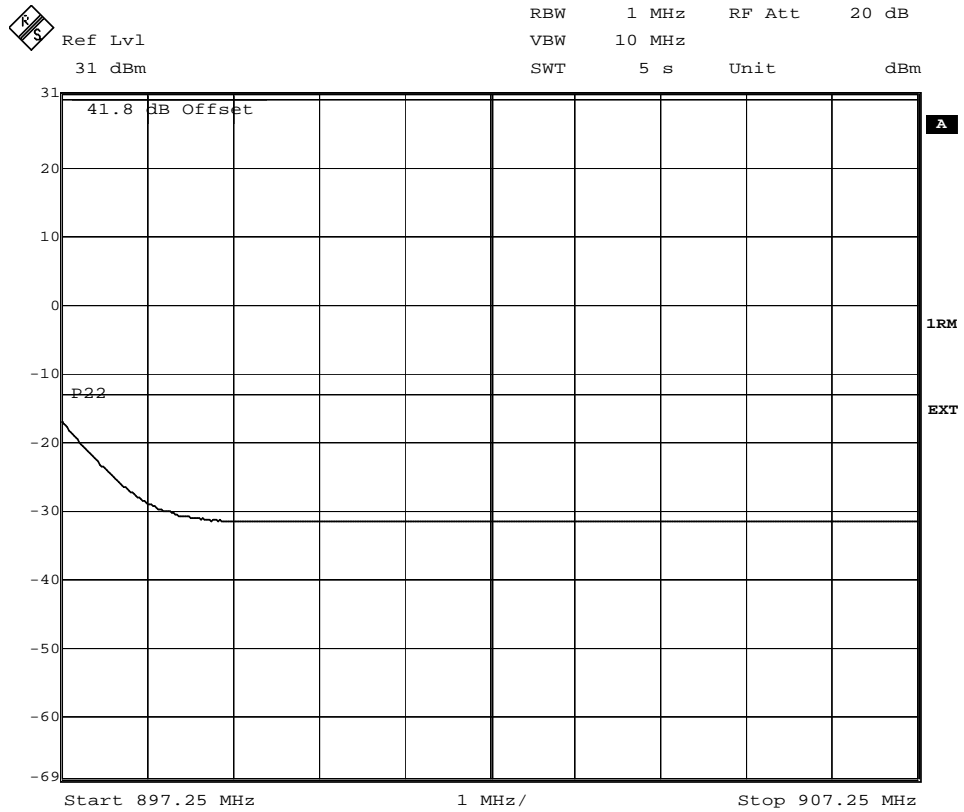

Date: 20.MAY.2009 12:50:14



FCC ID: TA8AKRC11846-2
IC: 287AB-AW118462

Appendix 4.1

Diagram 3

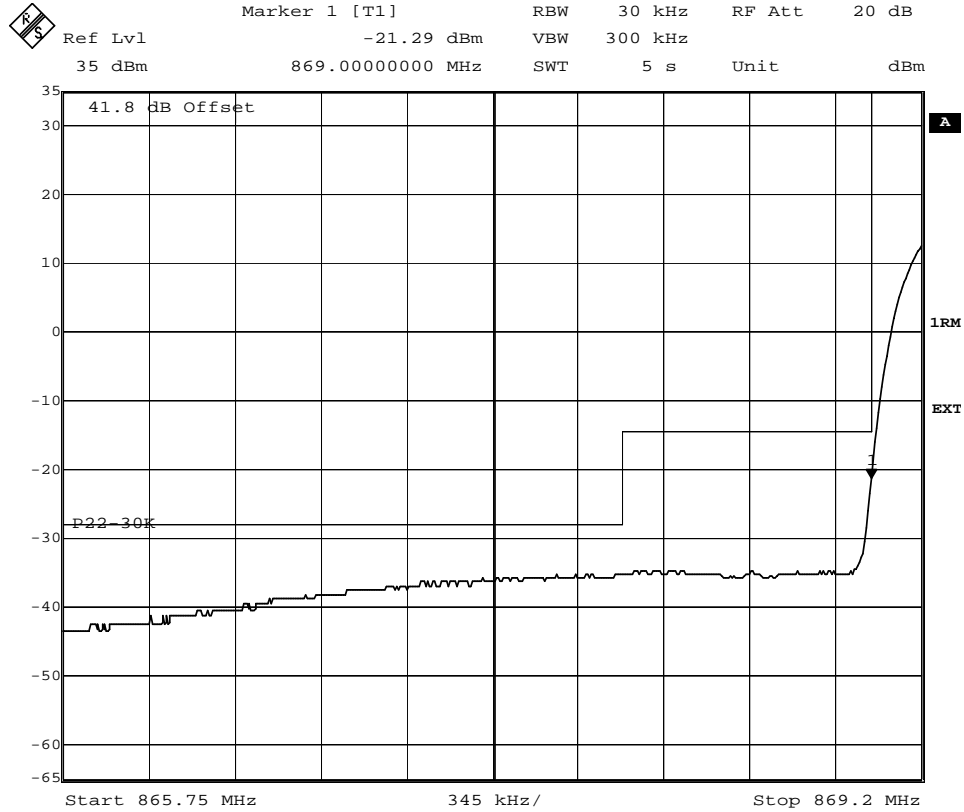

Date: 20.MAY.2009 15:15:28

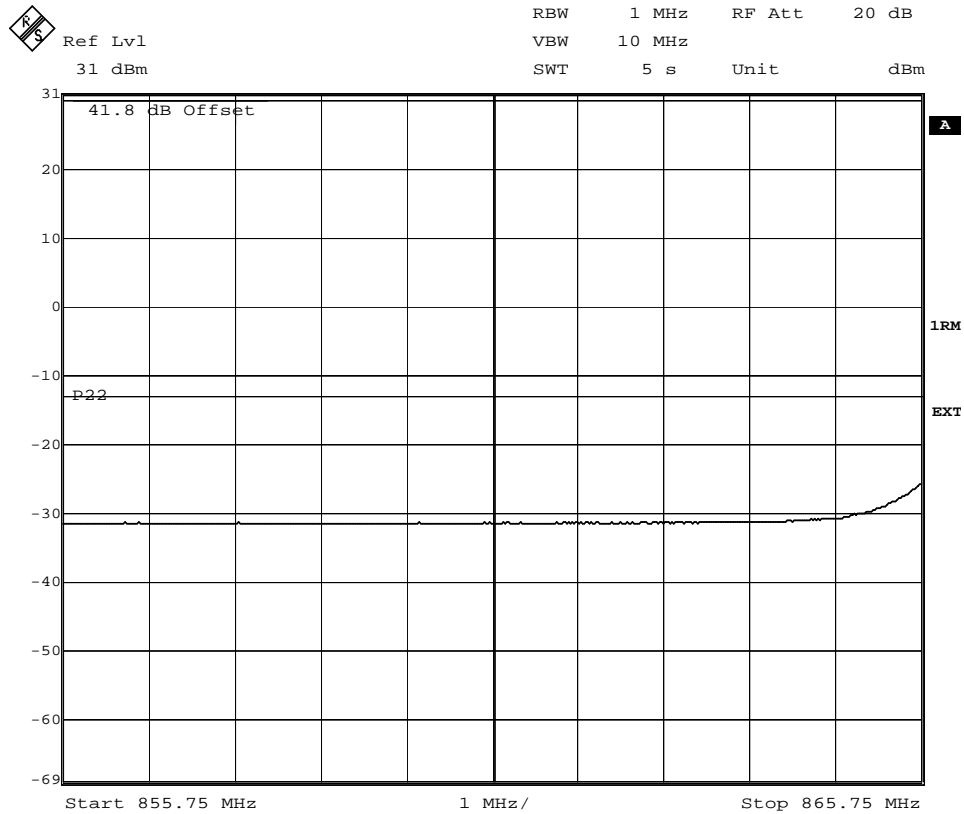

Date: 20.MAY.2009 15:16:23



FCC ID: TA8AKRC11846-2
IC: 287AB-AW118462

Appendix 4.1

Diagram 4

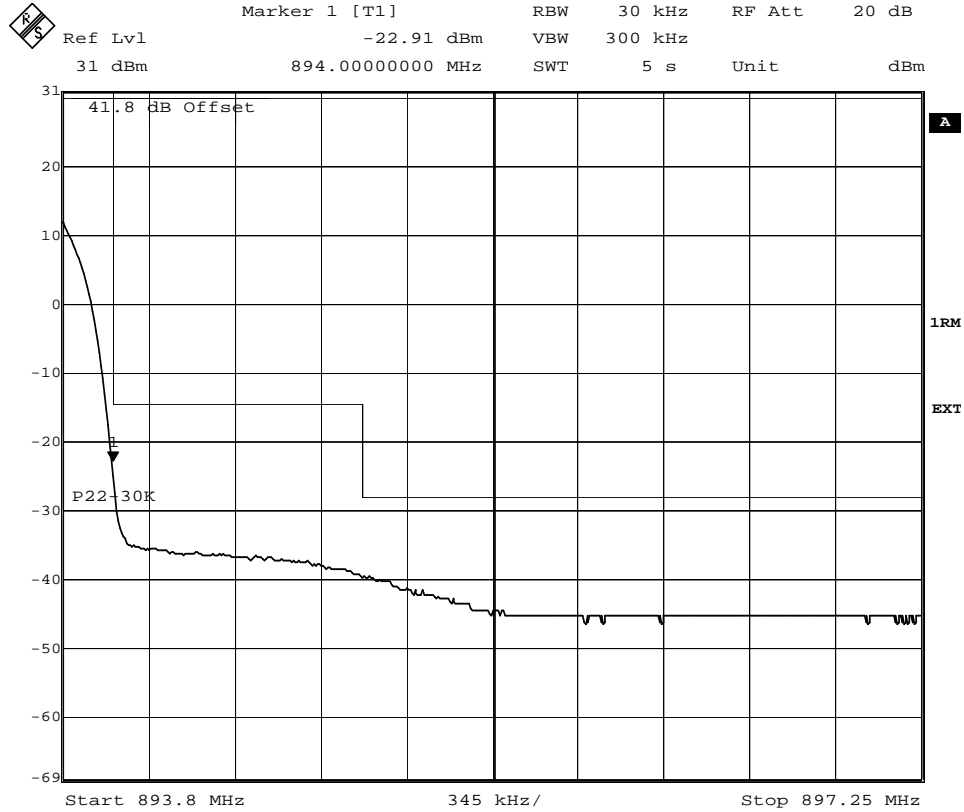

Date: 25.MAY.2009 09:23:04

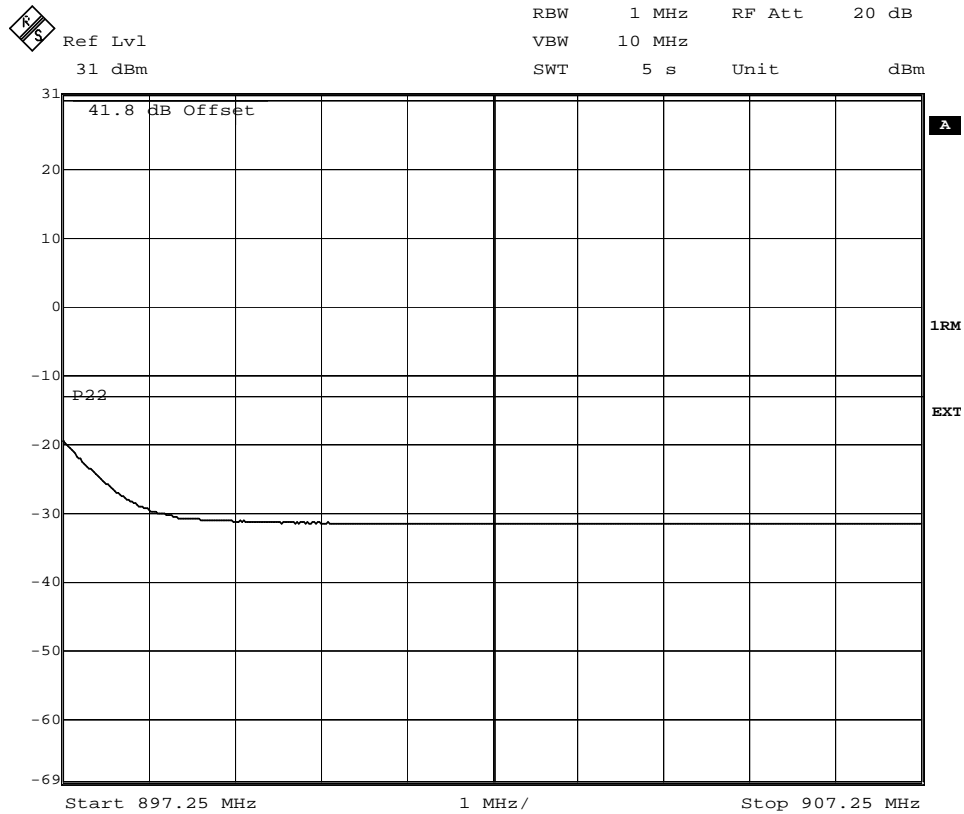

Date: 25.MAY.2009 09:23:56



FCC ID: TA8AKRC11846-2
IC: 287AB-AW118462

Appendix 5

**Conducted spurious emission measurements according to 47 CFR 2.1051/
RSS-132 4.5**

Date	Temperature	Humidity
2009-05-19	22 °C ± 3 °C	40 % ± 5 %
2009-05-20	22 °C ± 3 °C	36 % ± 5 %
2009-05-25	22 °C ± 3 °C	36 % ± 5 %

Test set-up and procedure

The measurements were made with a resolution bandwidth of 1 MHz instead of 100 kHz as RSS-132 specifies 1 MHz for equipment with an emission bandwidth of ≥4 MHz. The output was connected to a spectrum analyzer. First a pre-measurement with activated peak detector was performed. Emissions close to or above the limit is measured with activated RMS detector and the RMS measurement result is noted. The spectrum analyzer was connected to an external 10 MHz reference standard during the measurements.

Measurement equipment	SP number
R&S FSIQ	503 738
High pass filter	503 739
Testo 615, Temperature and humidity meter	503 505

Measurement uncertainty: 3.7 dB

Results

The results are shown in appendix 5.1

Single carrier:

Diagram 1: 871.4 MHz

Diagram 2: 881.6 MHz

Diagram 3: 891.6 MHz

Multi carrier:

Diagram 4: 871.4+881.4 MHz

Diagram 5: 881.6+891.6 MHz

Remark

The emission at 9 kHz on the plots was not generated by the test object. A complementary measurement with a smaller RBW showed that it was related to the LO feed-through.

Limits

The power of any emission outside the frequency band shall be attenuated below the transmitter power (P) by at least 43 + 10 log P dB.

Complies?	Yes
-----------	-----



FCC ID: TA8AKRC11846-2
IC: 287AB-AW118462

Appendix 5.1

Diagram 1

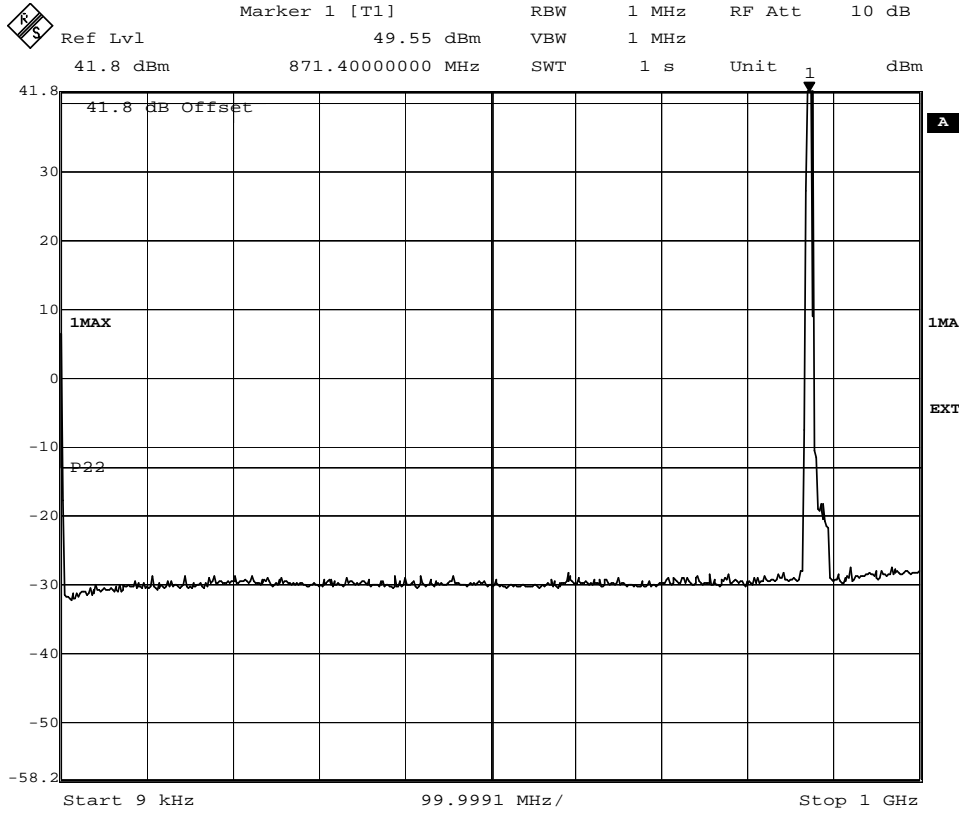

Date: 19.MAY.2009 15:44:22

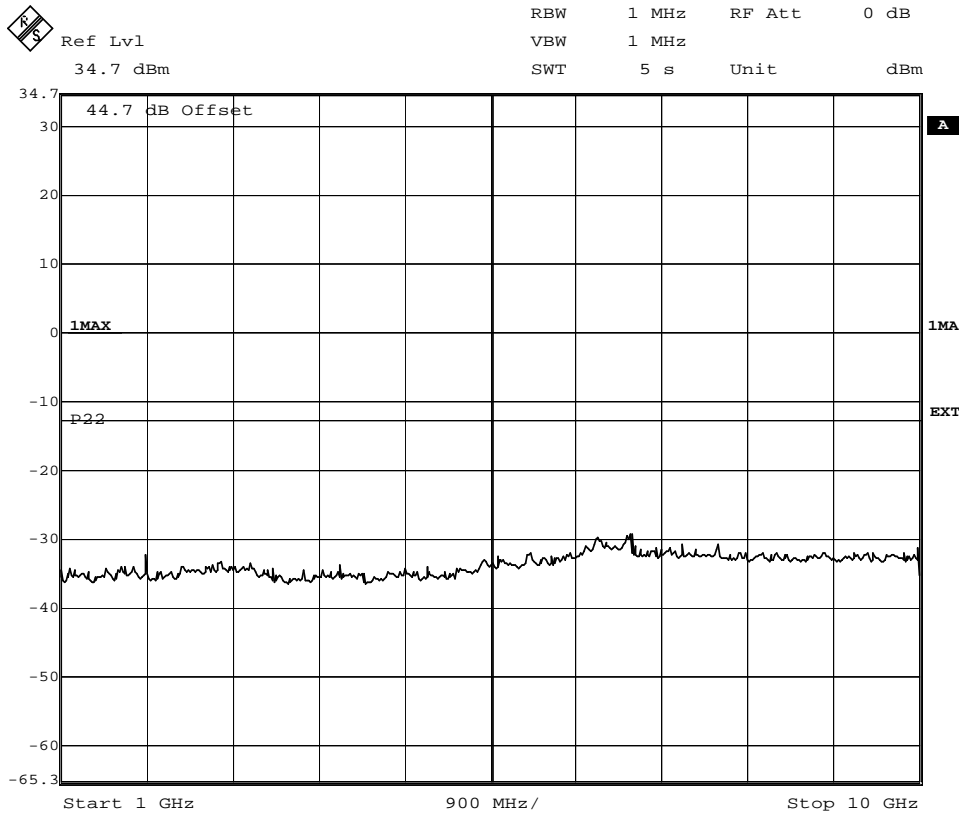

Date: 20.MAY.2009 13:36:47



FCC ID: TA8AKRC11846-2
IC: 287AB-AW118462

Appendix 5.1

Diagram 2

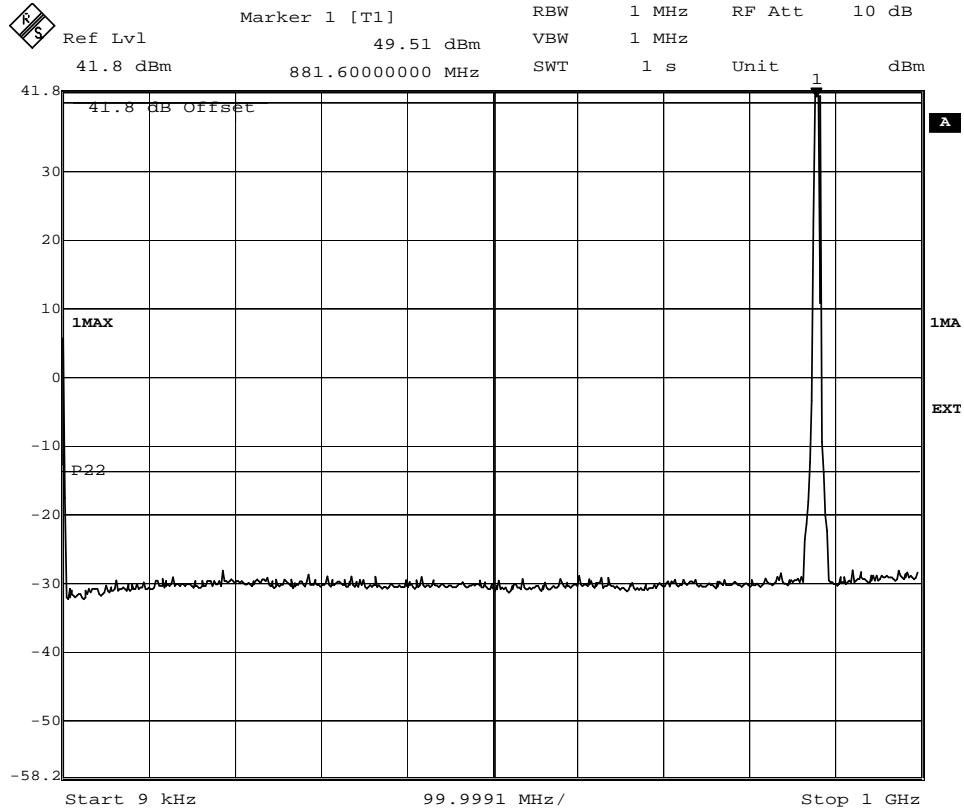

Date: 20.MAY.2009 12:11:45

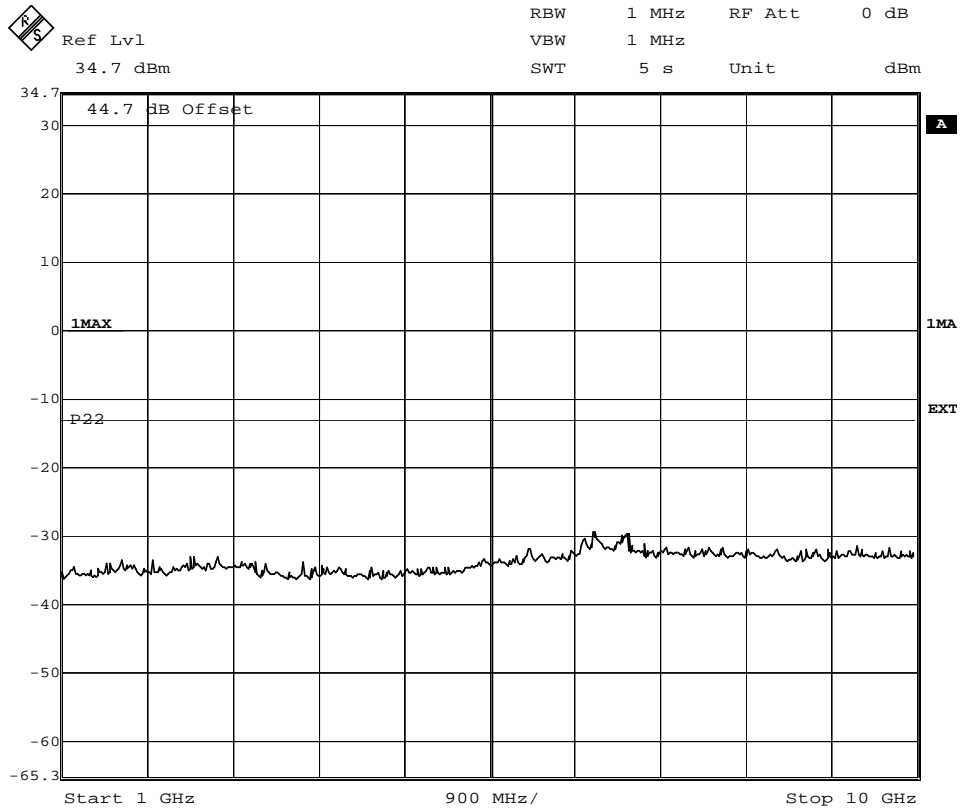

Date: 20.MAY.2009 12:15:06



FCC ID: TA8AKRC11846-2
IC: 287AB-AW118462

Appendix 5.1

Diagram 3

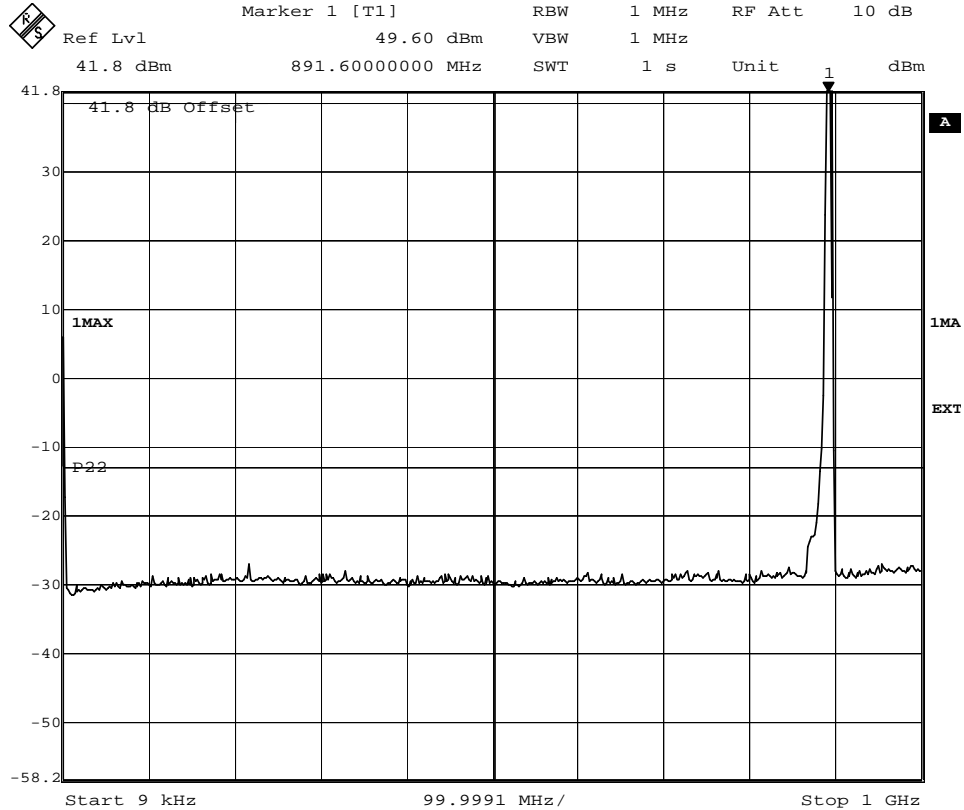

Date: 20.MAY.2009 12:55:15

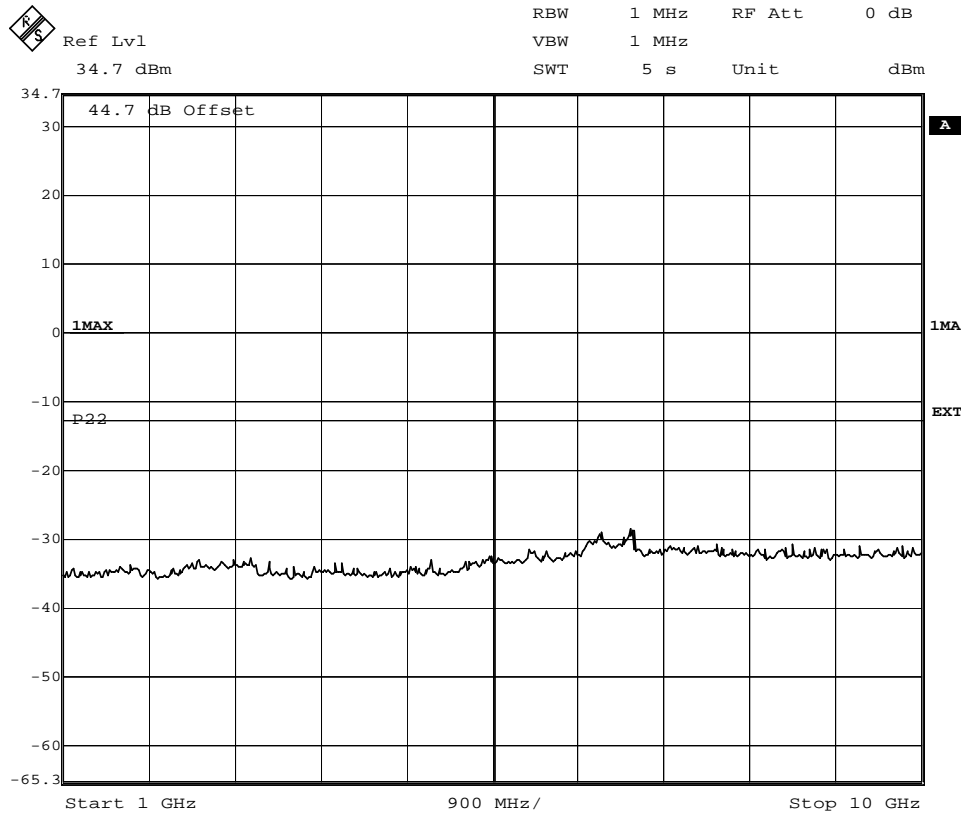

Date: 20.MAY.2009 13:02:18



FCC ID: TA8AKRC11846-2
IC: 287AB-AW118462

Appendix 5.1

Diagram 4

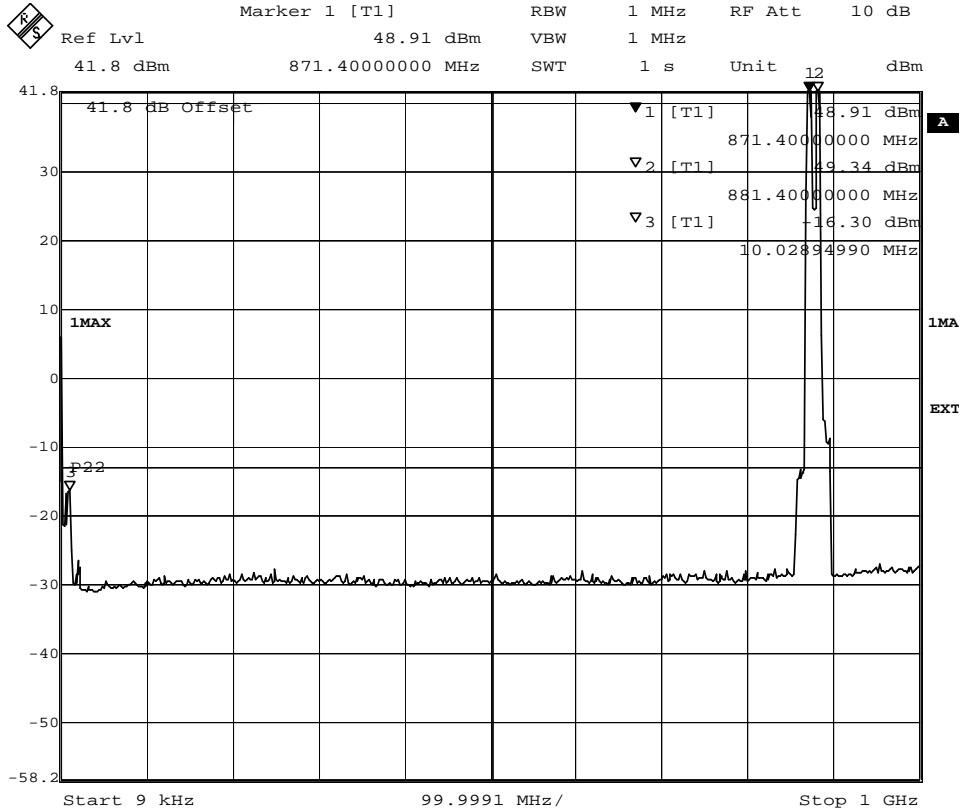

Date: 20.MAY.2009 14:53:09

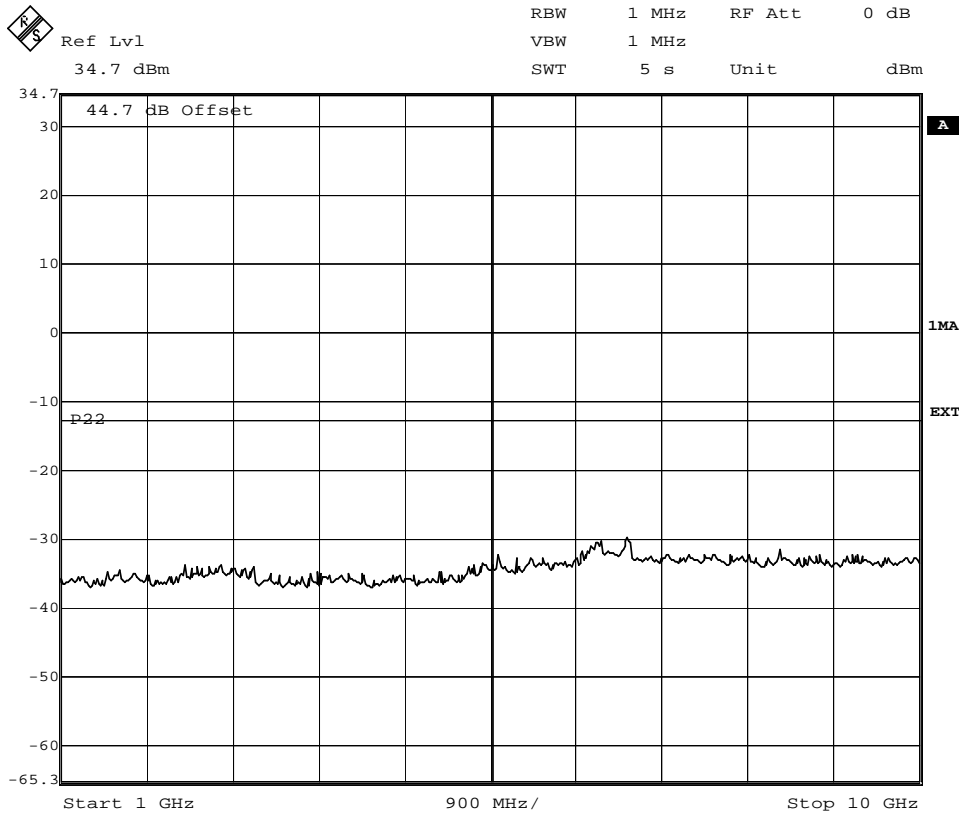

Date: 20.MAY.2009 15:05:35



FCC ID: TA8AKRC11846-2
IC: 287AB-AW118462

Appendix 5.1

Diagram 5

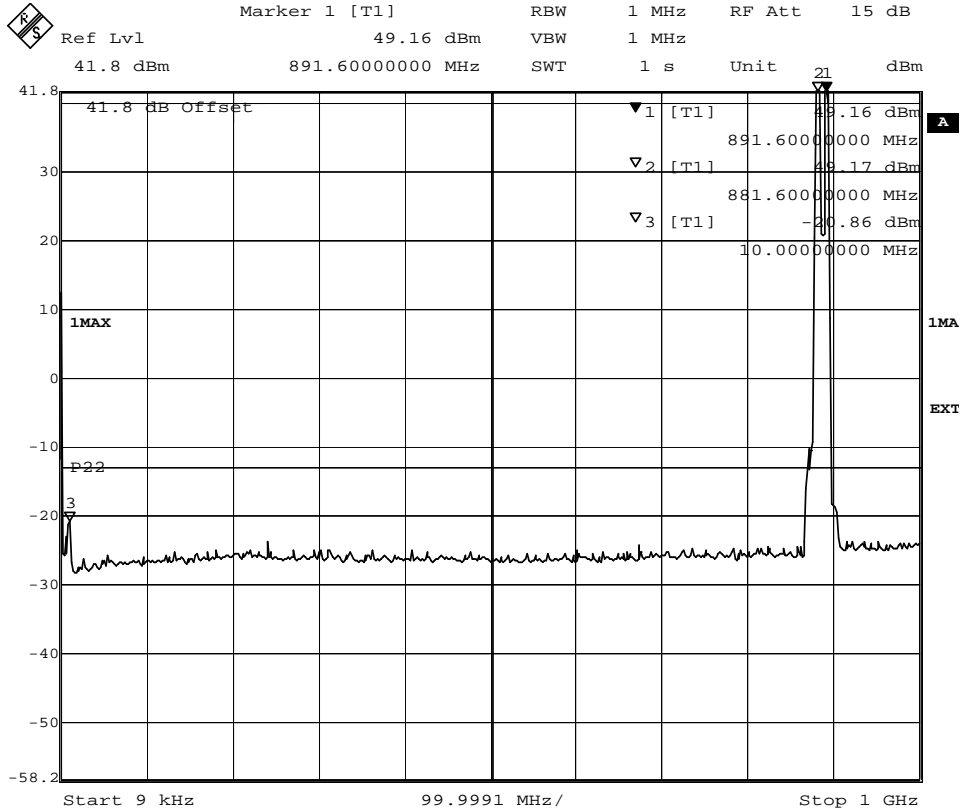

Date: 25.MAY.2009 09:00:23

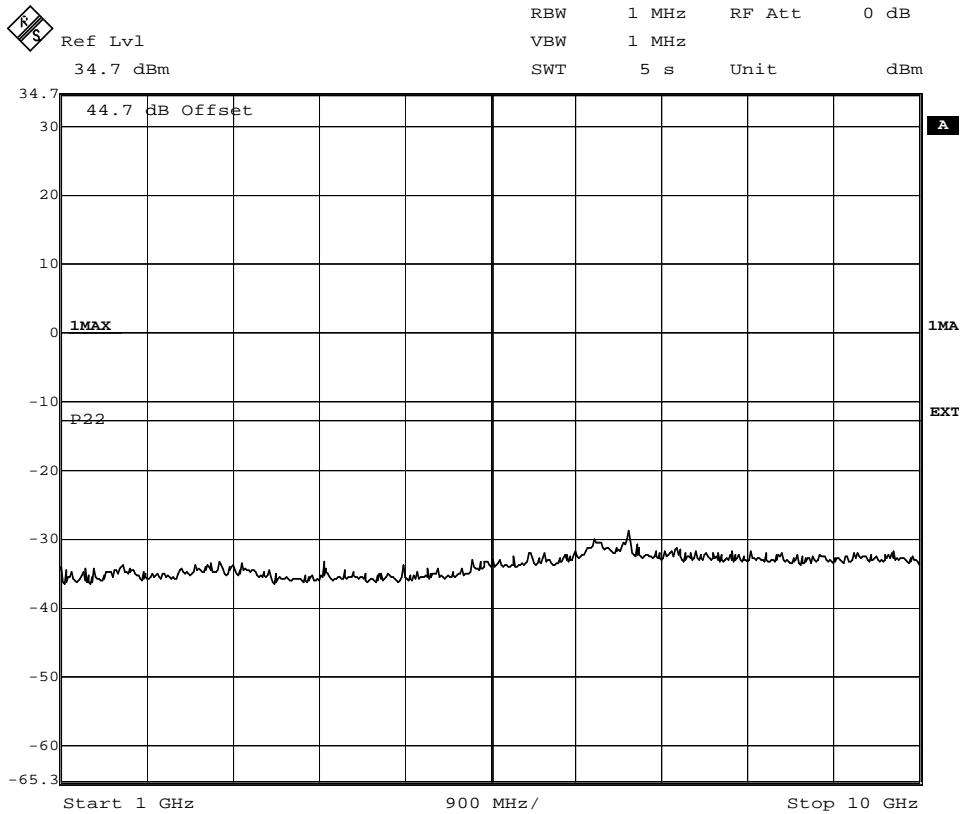

Date: 25.MAY.2009 09:09:29

FCC ID: TA8AKRC11846-2
 IC: 287AB-AW118462

Appendix 6

Field strength of spurious radiation measurements according to 47 CFR 2.1053/ RSS-132 4.5

Date 2009-05-11 to 2009-05-19	Temperature 22-23 °C ± 3 °C	Humidity 25-40 % ± 5 %
----------------------------------	--------------------------------	---------------------------

Test set-up and procedure

The test site is listed at FCC, Columbia with registration number: 93866. The test site also complies with RSS-Gen, Industry Canada file no.:IC 3482.

The transmitter was modulated with pseudorandom data during the measurements. Antenna port 1 was connected to functional test equipment outside the test chamber for signal monitoring. Antenna port 2 was terminated with a 50 ohm load.

The measurements were performed with both horizontal and vertical polarization of the antenna. The antenna distance was 3 m.

1. A pre-measurement was first performed:
2. In the frequency range 30 MHz-10 GHz the measurement was performed in power with a RBW of 1 MHz. A propagation loss in free space was calculated. The used formula was,

$$\gamma = 20 \log \left(\frac{4\pi D}{\lambda} \right), \gamma \text{ is the propagation loss and } D \text{ is the antenna distance.}$$

3. The measurement procedure was as the following:
4. The pre-measurement was first performed with peak detector. The EUT was measured in eight directions and with the antenna at three heights, 1.0 m, 1.5 m and 2.0 m.
5. Spurious radiation on frequencies closer than 20 dB to the limit is scanned 0-360 degrees and the antenna is scanned 1-4 m for maximum response. The emission is then measured with the RMS detector and the RMS value is reported, frequencies closer than 10 dB to the limit measured with the RMS detector were measured with the substitution method according to the standard.

Measurement equipment	SP number
Test site Tesla	503 881
R&S ESI 26	503 292
Control computer	503 479
Software: R&S EMC32, ver. 6.30.10	-
Chase Bilog antenna CBL 6111A	502 182
EMCO Horn Antenna 3115	502 175
MITEQ Low Noise Amplifier	503 285
Testo 615, Temperature and humidity meter	503 505

FCC ID: TA8AKRC11846-2
 IC: 287AB-AW118462

Appendix 6

The test set-up during the spurious radiation measurements is shown in the picture below:



Results

Single carrier

Frequency (MHz)	Spurious emission level (dBm)	
	Vertical	Horizontal
30-10 000	All emission > 20 dB below limit	All emission > 20 dB below limit
Measurement uncertainty 4.7 dB		

Multi carrier

Frequency (MHz)	Spurious emission level (dBm)	
	Vertical	Horizontal
30-10 000	All emission > 20 dB below limit	All emission > 20 dB below limit
Measurement uncertainty 4.7 dB		



REPORT

FCC ID: TA8AKRC11846-2
IC: 287AB-AW118462

Appendix 6

Limits

The power of any emission outside the frequency band shall be attenuated below the transmitter power (P) by at least $43 + 10 \log P$ dB.

Complies?	Yes
-----------	-----

FCC ID: TA8AKRC11846-2
IC: 287AB-AW118462

Appendix 7

Frequency stability according to 47 CFR 2.1055/ RSS-132 4.3

Date	Temperature (test equipment)	Humidity (test equipment)
2009-05-25	21°C ± 3 °C	43 % ± 5 %
2009-05-26	23°C ± 3 °C	33 % ± 5 %
2009-05-27	23°C ± 3 °C	34 % ± 5 %

Test set-up and procedure

The measurement was made per 3GPP TS 25.141. The output was connected to a spectrum analyzer. The spectrum analyzer was connected to an external 10 MHz reference standard during the measurements.

Measurement equipment	SP number
R&S FSQ 40	504 143
Testo 615, Temperature and humidity meter	503 505
Climate chamber 2	501 031

Results

Nominal Voltage -48 V DC

Maximum output power at 881.6 MHz: 1x 47.8 dBm, TM1

Test conditions		Frequency error (Hz)
Supply voltage DC (V)	T (°C)	
-48.0	+20	-11
-55.2	+20	-7
-40.8	+20	-8
-48.0	+30	-9
-48.0	+40	-8
-48.0	+50	-11
-48.0	+10	-6
-48.0	0	-7
-48.0	-10	-8
-48.0	-20	-7
-48.0	-30	-6
Maximum freq. error (Hz)		-11
Measurement uncertainty		< ± 1 x 10 ⁻⁷

Limits (according to 3GPP TS 25.141)

The frequency error shall be within ± 0.05 PPM ± 12 Hz (56.1 Hz).

Complies?	Yes
-----------	-----



FCC ID: TA8AKRC11846-2
IC: 287AB-AW118462

Appendix 8

**Receiver spurious emissions measurements according to 47 CFR 15.111/
IC RSS-132, section 4.6.**

Date 2009-05-20	Temperature 22°C ± 3 °C	Humidity 36 % ± 5 %
--------------------	----------------------------	------------------------

Test set-up and procedure

The measurements were performed according to ANSI C63.4.

Measurements were performed on the receiver antenna terminal (Ant 2). The measurement is first performed with peak detector. Emission on frequencies close to or above the limit is re-measured with quasi-peak detector (average detector above 1000 MHz).

Measurement equipment	SP number
R&S FSIQ 40	503 738
Testo 615, Temperature and humidity meter	503 505

Result

The results are shown in appendix 8.1:

	Rx frequency
Diagram 1	826.4 MHz
Diagram 2	836.6 MHz
Diagram 3	846.6 MHz

Note: During the measurement on the RX port Ant 2 the combined TX/RX port Ant 1 was terminated into 50 ohm, the TX was active in single carrier mode transmitting TM1.

Remark

The emission at 9 kHz on the plots was not generated by the test object. A complementary measurement with a smaller RBW showed that it was related to the LO feed-through.

Limit

The power of any spurious output signals appearing at the antenna terminals must not exceed -57 dBm (2 nanowatt).

Emission below limit?	Yes
-----------------------	-----



FCC ID: TA8AKRC11846-2
IC: 287AB-AW118462

Appendix 8.1

Diagram 1

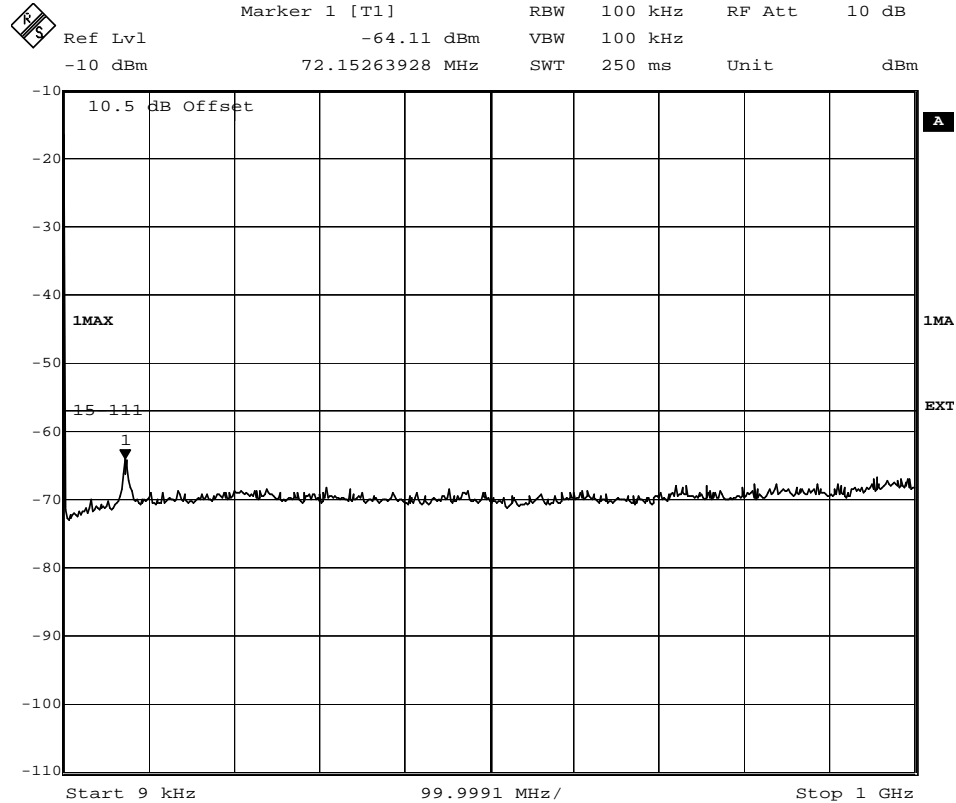

Date: 20.MAY.2009 13:56:27

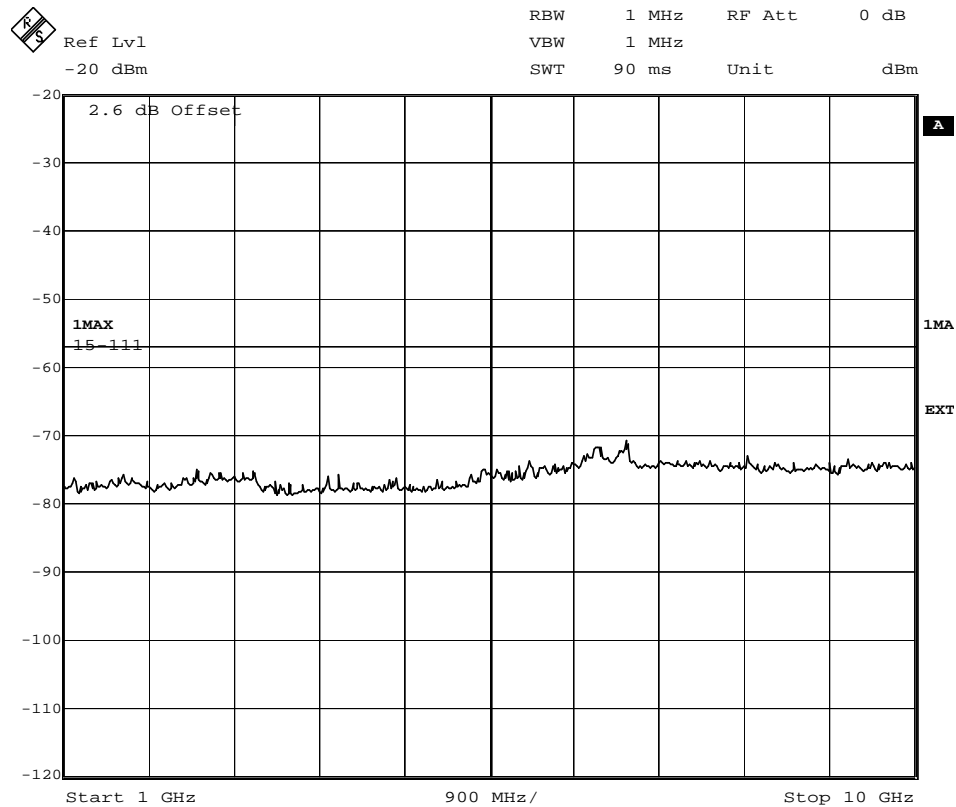

Date: 20.MAY.2009 13:53:05



FCC ID: TA8AKRC11846-2
IC: 287AB-AW118462

Appendix 8.1

Diagram 2

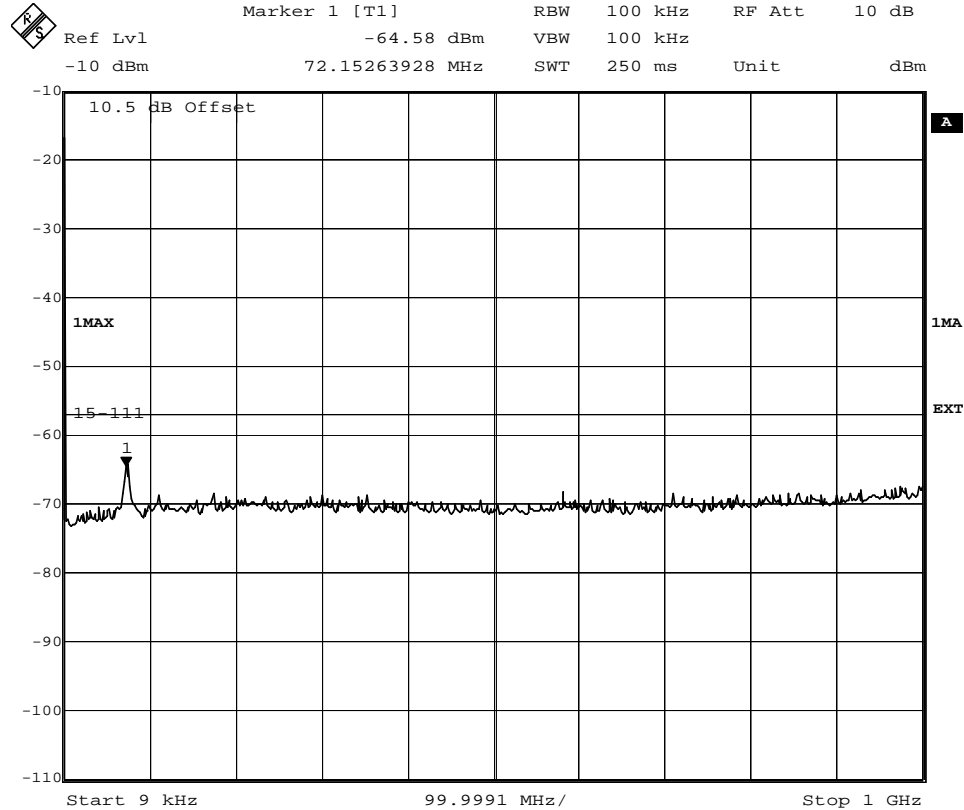

Date: 20.MAY.2009 14:07:22

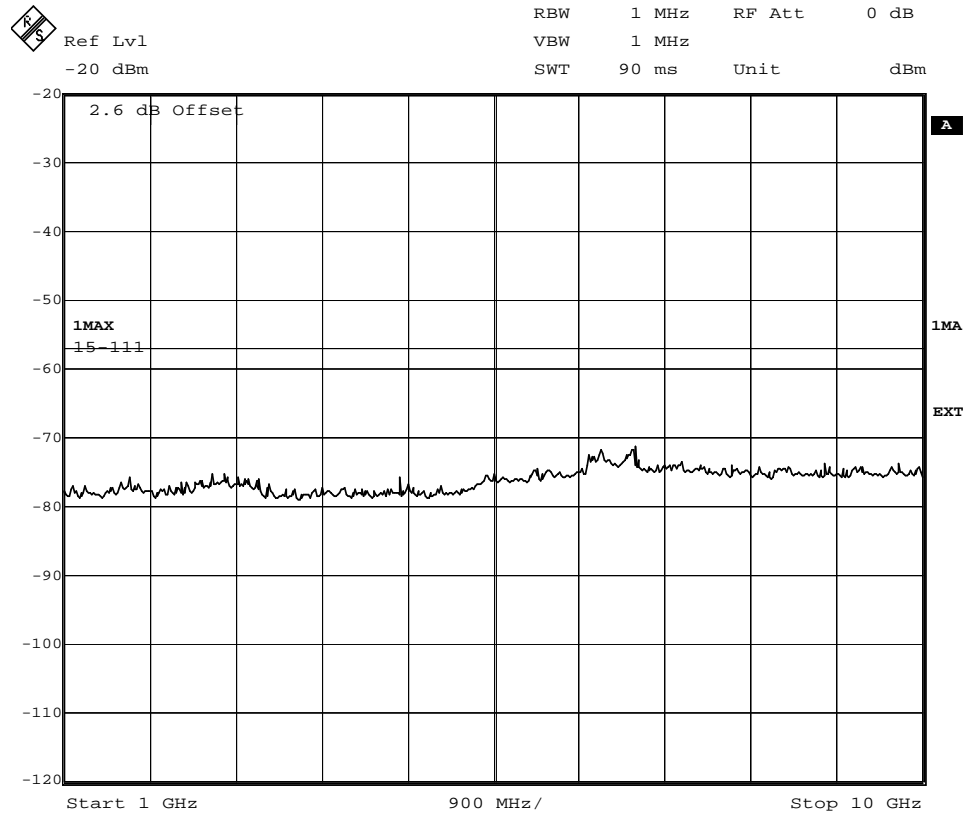

Date: 20.MAY.2009 14:09:37



FCC ID: TA8AKRC11846-2
IC: 287AB-AW118462

Appendix 8.1

Diagram 3

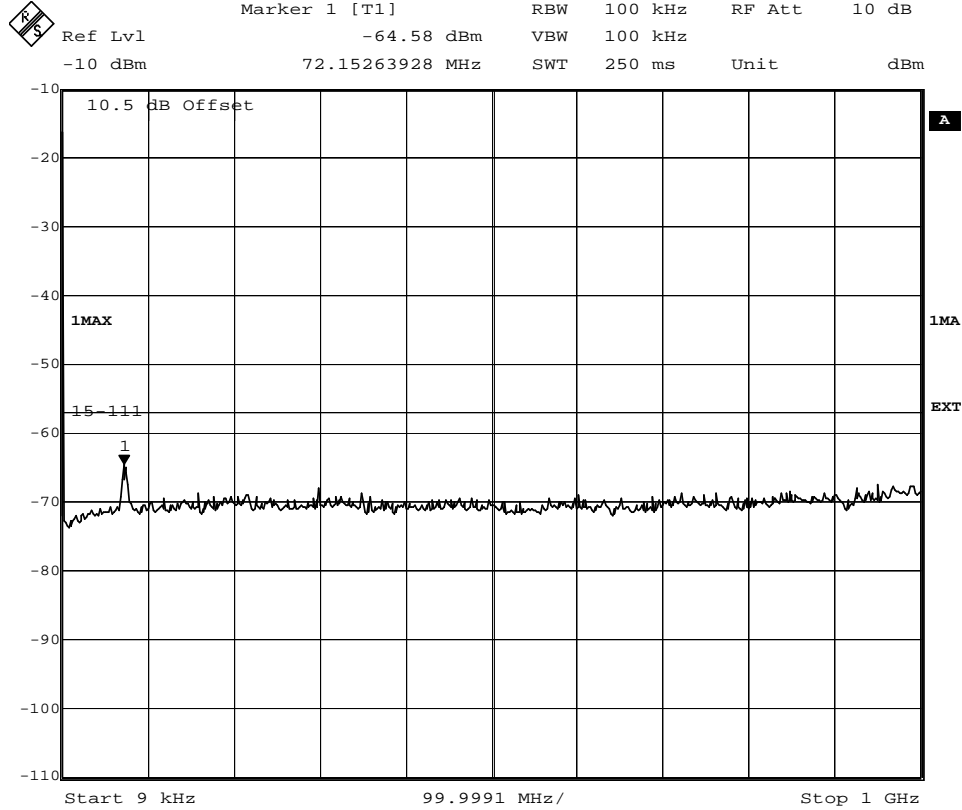

Date: 20.MAY.2009 14:30:19

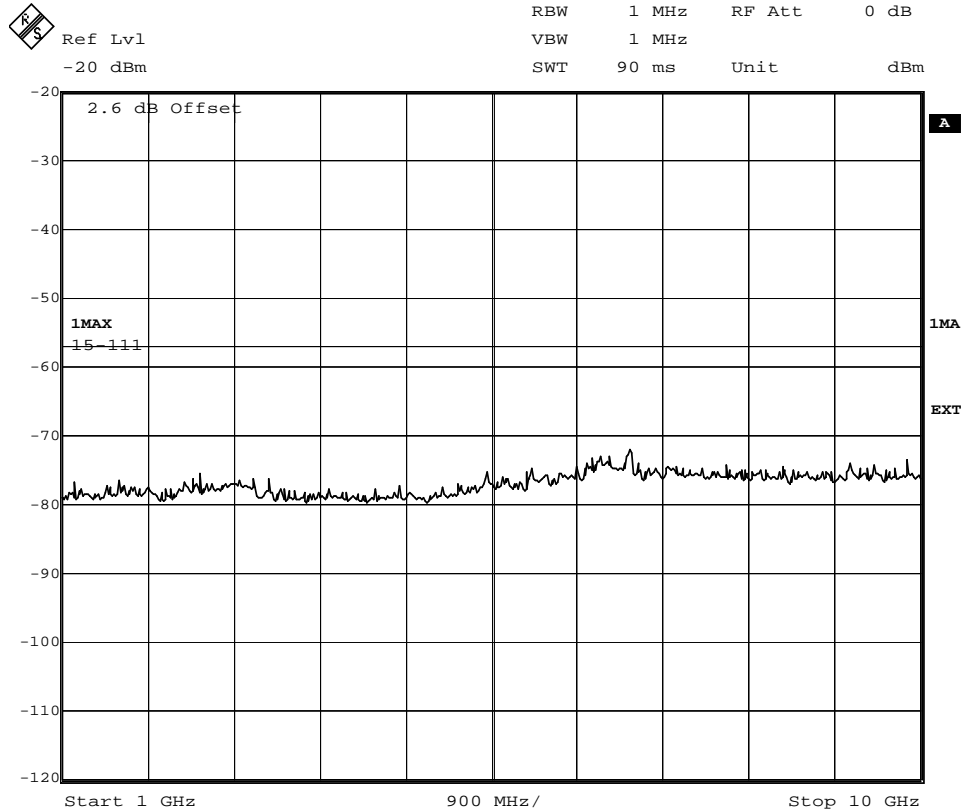

Date: 20.MAY.2009 14:29:07

FCC ID: TA8AKRC11846-2
IC: 287AB-AW118462

Appendix 9

External photos of EUT

Front side



Rear side

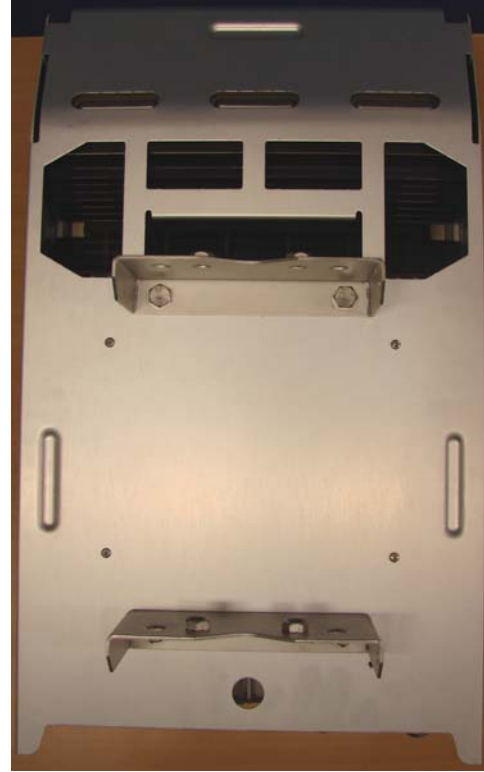

Right side



Left side



FCC ID: TA8AKRC11846-2
IC: 287AB-AW118462

Appendix 9

(External photos continued)

Bottom side



Top side

