



Product Service

**Choose certainty.
Add value.**



Report On

Limited FCC and IC Testing of the
Ericsson LTE and CDMA RRUS 31 B25 (1900 MHz) Base Station in
accordance with FCC CFR 47 Part 2 and 24 and Industry Canada
RSS-133 and RSS-GEN

COMMERCIAL-IN-CONFIDENCE

FCC ID: TA8AKRC118159-1 and IC ID: 287AB-AS1181591

PREPARED BY

A handwritten signature in black ink, appearing to read 'S. Bennett', written over a horizontal line.

Simon Bennett
Senior Engineer

APPROVED BY

A handwritten signature in black ink, appearing to read 'M. Jenkins', written over a horizontal line.

Mark Jenkins
Authorised Signatory

DATED

19 December 2013

Document 75924539 Report 01 Issue 1

December 2013

CONTENTS

Section	Page No
1	REPORT INFORMATION 2
1.1	Report Details 3
1.2	Brief Summary of Results 4
1.3	Configuration Description 5
1.4	Declaration of Build Status 7
1.5	Product Information 8
1.6	Test Setup 9
1.7	Test Conditions 10
1.8	Deviation From The Standard 10
1.9	Modification Record 10
1.10	Alternative Test Site 10
1.11	Additional Information 10
2	TEST DETAILS 11
2.1	Maximum Peak Output Power and Peak to Average Ratio - Conducted 12
2.2	Occupied Bandwidth 45
2.3	Spurious Emissions at Band Edge 69
2.4	Conducted Spurious Emissions 90
2.5	Frequency Stability 116
3	TEST EQUIPMENT USED 119
3.1	Test Equipment Used 120
3.2	Measurement Uncertainty 121
4	DISCLAIMERS AND COPYRIGHT 122
4.1	Disclaimers and Copyright 123
ANNEX A	Module Lists A.2



Product Service

SECTION 1

REPORT INFORMATION

1.1 REPORT DETAILS

Manufacturer	Ericsson
Address	349 Terry Fox Drive Ottawa Ontario K2K 2V6 Canada
Product Name	RRUS 31 B25
Product Number	KRC 118 159/1
IC Model Name	AS1181591
Serial Number(s)	D74DA00020
Software Version	R1C 06, R1E
Hardware Version	R1C
Test Specification/Issue/Date	FCC CFR 47 Part 2: 2012 FCC CFR 47 Part 24: 2012 Industry Canada RSS-133: Issue 6: 2013 Industry Canada RSS-GEN Issue 3: 2010
Start of Test	05 November 2013
Finish of Test	20 November 2013
Name of Engineer(s)	Simon Bennett Stephen Milliken
Related Document(s)	ANSI C63.4: 2009

ENGINEERING STATEMENT

The measurements shown in this report were made in accordance with the procedures described on test pages. All reported testing was carried out on a sample equipment to demonstrate limited compliance with FCC CFR Part 2, FCC CFR Part 24, Industry Canada RSS-133 and Industry Canada RSS-GEN. The sample tested was found to comply with the requirements defined in the applied rules.

Test Engineer(s);

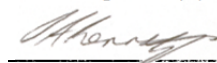

Simon Bennett

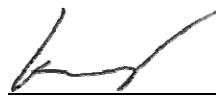

Stephen Milliken

1.2 BRIEF SUMMARY OF RESULTS

A brief summary of results for each configuration, in accordance with FCC CFR 47 Part 2 and 24 and Industry Canada RSS-133 and RSS-GEN is shown below.

Section	Spec Clause				Test Description	Result
	Part 2	Part 24	RSS-133	RSS-GEN		
2.1	2.1046	24.232(a)	6.4	-	Maximum Peak Output Power and Peak to Average Ratio – Conducted	Pass
2.2	2.1049(h)	24.238(b)	-	4.6	Occupied Bandwidth	Pass
2.3	2.1051	24.238	6.5	-	Spurious Emissions at Band Edge	Pass
2.4	2.1051	24.238(a)	6.5	-	Conducted Spurious Emissions	Pass
2.5	2.1055	24.235	6.3	-	Frequency Stability	Pass
-	-	-	-	4.10	Receiver Spurious Emissions	Pass*
-	2.1053	24.238	6.5	-	Transmitter Radiated Emissions	Pass*

N/A – Not Applicable

* See test report from Flextronics Design Validation Centre, Canada Report Reference Number K0002333-TR-RAD-01-01

1.3 CONFIGURATION DESCRIPTION

The RRUS 31 B25 / KRC 118 159/1 supports Single, Dual, 3 and 4 Carrier operation from either a single, dual or 4 port configuration. A pre-test was performed to establish the worst case configuration of the EUT in the above mentioned operating modes. The reported results represent testing in the worst case modes of operation. Testing was carried out on all test ports to confirm that each antenna output was electrically identical. Results of these tests are available on request.

The RRUS 31 B25 / KRC 118 159/1 supports Test Models E-TM1.1, E-TM3.2 and E-TM3.1 at 1930 – 1990 MHz. The following test models were used as defined in 3GPP TS 36.141. Test Model E-TM1.1 was used to represent QPSK modulation only, Test Model E-TM3.2 was used to represent 16QAM modulation, and Test Model E-TM3.1 was used to represent 64QAM modulation.

The settings below were found to be representative for all traffic scenarios when several settings with the different modulations, channel bandwidths were tested to find the worst case setting. These settings were used for all measurements unless otherwise noted:

LTE: Test Model E-TM1.1 in channel bandwidth 5MHz and 20MHz.

CDMA: Test Model CDOSM2 2 1xEV-DO - QPSK Modulation, 1.25MHz bandwidth

Test Model CDOSM3 - 16QAM Modulation, 1.25MHz bandwidth

Test Model CDMA_1xEV_DO_8PSK_3frames_Test.cd12 – 8PSK Modulation, 1.25MHz bandwidth

For TX test cases: Maximum Conducted Output Power, Spurious Emissions at Antenna Terminals (± 1 MHz) and Conducted Spurious Emissions, measurements were performed on RF Port A using a test limit accounting for MIMO operation with 4 ports. All RF ports were tested for RF Carrier Power and results recorded using the Measure and Sum approach to account for MIMO operation. All testing was performed with the EUT transmitting at maximum RF power unless otherwise stated.

The RRUS 31 B25 operates over Band 25 from 1930MHz to 1995MHz for LTE and Mixed-Mode configurations. CDMA/EVDO configurations are limited to 1930MHz to 1990MHz (Band 2).

The EUT was powered by a -48V DC Power supply.

Channel Configurations

1930 MHz - 1990 MHz

All tests except Band Edge Emissions

Mode Description	RAT	Number of Carriers	Bandwidth	Carrier Frequency Configuration (MHz)		
				Bottom	Middle	Top
CDMA-SC	CDMA	1	1.25 MHz	1931.50	1960.00	1988.75
CDMA-MC1	CDMA	2	1.25 MHz	-	1931.25 + 1988.75	-
CDMA-MC2	CDMA	4	1.25 MHz	-	1931.25 + 1932.5 + 1987.50 + 1988.75	-
LTE-SC	LTE	1	5 MHz	1932.50	1960.00	1987.50
LTE-SC	LTE	1	10 MHz	1935.00	1960.00	1985.00
LTE-SC	LTE	1	15 MHz	1937.50	1960.00	1982.50
LTE-SC	LTE	1	20 MHz	1940.00	1960.00	1980.00
LTE-MC1	LTE	2	5 MHz	-	1932.50 + 1987.50	-
LTE-MC1	LTE	2	10 MHz	-	1935.00 + 1985.00	-
LTE-MC1	LTE	2	15 MHz	-	1937.50 + 1982.50	-
LTE-MC1	LTE	2	20 MHz	-	1940.00 + 1980.00	-
LTE-MC2	LTE	4	5 MHz	-	1932.50 + 1937.50 + 1982.50 + 1987.50	-
LTE-MC2	LTE	4	10 MHz	-	1935.00 + 1945.00 + 1975.00 + 1985.000	-
LTE+CDMA-MC1	LTE+CDMA	LTE: 1 CDMA: 1	LTE: 5 MHz CDMA: 1.25 MHz	-	LTE: 1987.50 CDMA: 1931.25	-
LTE+CDMA-MC1	LTE+CDMA	LTE: 1 CDMA: 1	LTE: 20 MHz CDMA: 1.25 MHz	-	LTE: 1980.00 CDMA: 1931.25	-
LTE+CDMA-MC2	LTE+CDMA	LTE: 2 CDMA: 2	LTE: 5 MHz CDMA: 1.25 MHz	-	LTE: 1957.50 + 1962.50 CDMA: 1931.25 + 1988.75	-

Table 1

Band Edge Emissions

Mode Description	RAT	Number of Carriers	Bandwidth	Carrier Frequency Configuration (MHz)	
				BRFBW (Bottom Edge)	TRFBW (Top Edge)
CDMA-SC	CDMA	1	1.25 MHz	1931.25	1988.75
CDMA-MC1	CDMA	2	1.25 MHz	1931.25 + 1932.50	1987.50 + 1988.75
LTE-SC	LTE	1	5 MHz	1932.50	1987.50
LTE-SC	LTE	1	10 MHz	1935.00	1985.00
LTE-SC	LTE	1	15 MHz	1937.50	1982.50
LTE-SC	LTE	1	20 MHz	1940.00	1980.00
LTE-MC1	LTE	2	5 MHz	1932.50 + 1937.50	1982.50 + 1987.50
LTE-MC1	LTE	2	10 MHz	1935.00 + 1945.00	1975.00 + 1985.00
LTE-MC1	LTE	2	15 MHz	1937.50 + 1952.50	1967.50 + 1982.50
LTE-MC1	LTE	2	20 MHz	1940.00 + 1960.00	1960.00 + 1980.00
LTE+CDMA-MC1	LTE+CDMA	LTE: 1 CDMA: 1	LTE: 15 MHz CDMA: 1.25 MHz	LTE: 1939.40 CDMA: 1931.25	LTE: 1980.60 CDMA: 1988.75

Table 2

1.4 DECLARATION OF BUILD STATUS

MAIN EUT	
MANUFACTURING DESCRIPTION	Remote Radio Unit – Multi-standard
MANUFACTURER	Ericsson Canada
TYPE	Radio Base Station
PART NUMBER	KRC 118 159/1
SERIAL NUMBER	D74DA0020
HARDWARE VERSION	R1C
SOFTWARE VERSION	R1C 06, R1E
TRANSMITTER OPERATING RANGE	1930MHz – 1995MHz
RECEIVER OPERATING RANGE	1850MHz – 1915MHz
COUNTRY OF ORIGIN	Japan
INTERMEDIATE FREQUENCIES	Direct Conversion
EMISSION DESIGNATOR(S): (i.e. G1D, GXW)	LTE 5M00 W7D 10M0 W7D 15M0 W7D 20M0 W7D CDMA/EVDO 1M25 F9W
MODULATION TYPES: (i.e. GMSK, QPSK)	LTE: QPSK, 16QAM, 64QAM CDMA: QPSK, 8PSK, 16QAM
HIGHEST INTERNALLY GENERATED FREQUENCY	1698.18MHz
OUTPUT POWER (W or dBm)	4 x 40W
FCC ID	TA8AKRC118159-1
INDUSTRY CANADA ID	287AB-AS1181591
TECHNICAL DESCRIPTION (a brief description of the intended use and operation)	The RRUS 31 B25 is a multi-standard Remote Radio Unit (RRUS) forming part of the Ericsson Radio Base Station (RBS). The RRUS provides radio access for mobile and fixed devices and is designed for the outdoor environment, mounting on pole, wall or mast deployments. Altitude during operation: Below 3000m.

Signature
Date
D of B S Serial No

Held on file by TUV SUD Product Service
11 December 2013
D74DA0020

No responsibility will be accepted by TÜV SÜD Product Service as to the accuracy of the information declared in this document by the manufacturer.

1.5 PRODUCT INFORMATION

1.5.1 Technical Description

The RRUS 31 B25 is a multi-standard Remote Radio Unit (RRUS) forming part of the Ericsson RBS 6000 series Radio Base Station (RBS). The RRUS provides the radio access wireless interface for mobile and fixed devices and is designed for the outdoor environment.

Classed under ITE (Information Technology Equipment), the RRUS is designed to be co-located with the Base Station antenna for path loss optimization. A fibre optic interface provides the RRUS / RBS control and digital communications between the Radio and RBS. The location of the RRUS with respect to the RBS is only limited to a distance dictated by the limitations of the fibre link.

The RRUS 31 B25 supports four (4) Transmit / Receive ports at a Downlink transmit of 1930MHz to 1995MHz and an Uplink receive from 1850MHz to 1915MHz. The radio operates in FDD (Frequency Division Duplex) with a duplex spacing of 80MHz and supports operation on multi radio access transmission standards (RATS) at transmit bandwidths up to 20MHz. The supported RAT(s) for this radio are LTE, CDMA/EVDO as well as multi-mode LTE + CDMA/EVDO. CDMA/EVDO operation is limited from 1930MHz to 1990MHz. The radio operates over 4 transmit ports in single and multi-carrier mode with a rated RF output power of 40W per port over an operational temperature of -40° C to +55° C.

A full technical description can be found in the Manufacturer's documentation.

1.6 TEST SETUP

Test Setup, Conducted Measurement:

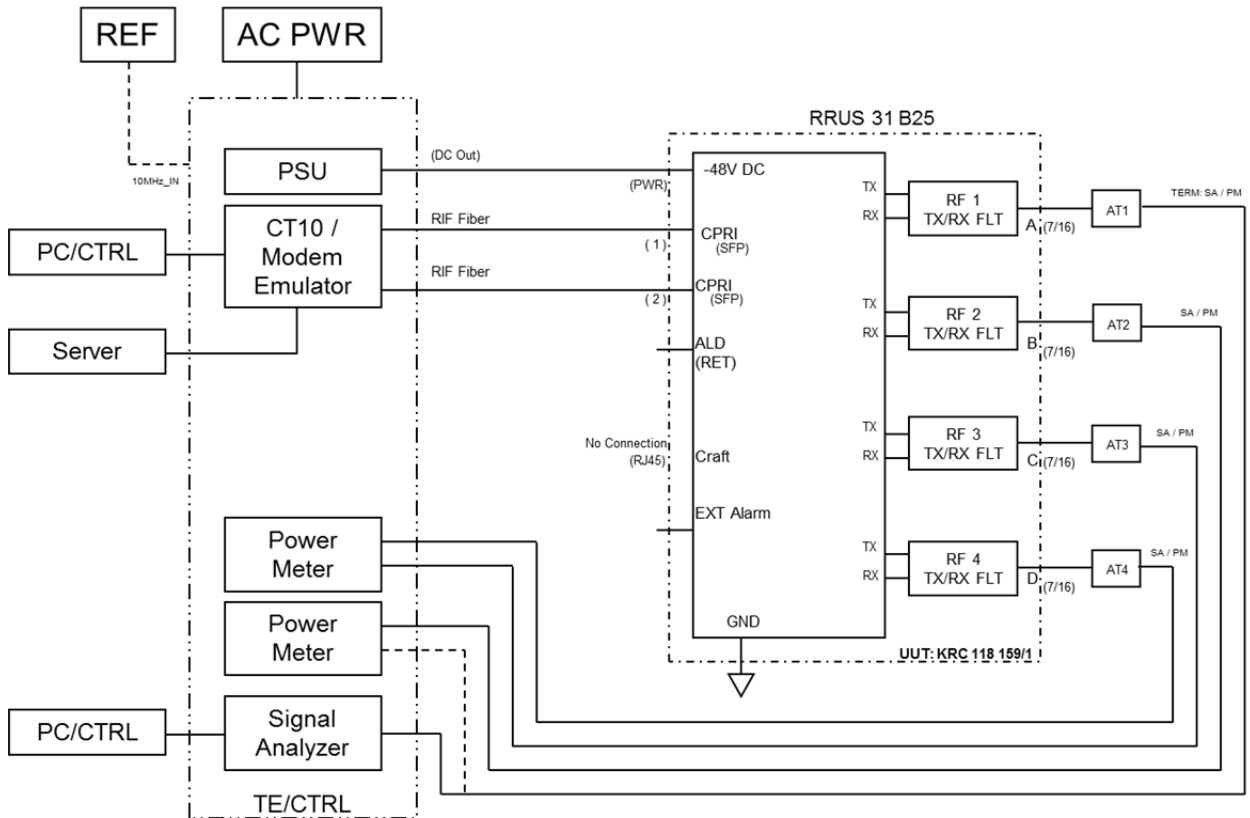

See Section 3 for a list of the test equipment used in the test.

Test Setup, Radiated Measurement:

See test report from Flextronics Design Validation Centre, Canada Report Reference Number K0002333-TR-RAD-01-01

1.7 TEST CONDITIONS

For all tests the EUT was set up in accordance with the relevant test standard and to represent typical operating conditions. Tests were applied with the EUT situated in a shielded enclosure, test laboratories or a chamber as appropriate.

The EUT was powered from a -48V DC supply.

1.8 DEVIATION FROM THE STANDARD

No deviations from the applicable test standards or test plan were made during testing.

1.9 MODIFICATION RECORD

Modification State 1

Software Release R1C 06 was used for all compliance testing with the exception of Frequency Stability. The latest software load R1E was used due to a limitation noted with the R1C 06 load which would not allow the radio to operate over the full voltage variation range. A limited suite of performance testing was repeated with R1E to ensure and validate the previous test results.

1.10 ALTERNATIVE TEST SITE

TÜV SÜD Product Service conducted the following tests at Ericsson in Ottawa, Canada.

1.11 ADDITIONAL INFORMATION

Testing was performed at the manufacturer's premises in Ottawa, Canada in the presence of Yuzhou Liu of Ericsson.

Testing was performed on Test Port A unless otherwise stated.

Prior to commencement of the test program, measurements were made in different carrier configurations to determine the worst case operating mode. The results reported indicate the identified worst case operating modes of the BTS. In addition, tests were performed on all ports to confirm that each radio was electrically identical.

Radiated Emissions testing was performed at Flextronics. See test report Flextronics K0002333-TR-RAD-01-01.



Product Service

SECTION 2

TEST DETAILS

2.1 MAXIMUM PEAK OUTPUT POWER AND PEAK TO AVERAGE RATIO - CONDUCTED

2.1.1 Specification Reference

FCC CFR 47 Part 2, Clause 2.1046
FCC CFR 47 Part 24, Clause 24.232(a)
Industry Canada RSS-133, Clause 6.4

2.1.2 Date of Test and Modification State

07, 08, 11 and 12 November 2013 - Modification State 0

2.1.3 Test Equipment Used

The major items of test equipment used for the above tests are identified in Section 3.1.

2.1.4 Environmental Conditions

Ambient Temperature	22.6 - 24.5°C
Relative Humidity	30.4 - 37.3%

2.1.5 Test Method

Measurements were performed with a Spectrum Analyser using the Band Power measurement function. The detector was set to RMS with an RBW of 300kHz and VBW of 1MHz. The detection bandwidth was configured to be wider than the total bandwidth of the carrier or combinations of carriers, (multi-carrier). Using a sweep time of 5 seconds, the average measurement was recorded. Prior to testing, comparative measurements were made with an Average Power sensor and Power Meter to confirm correlation with the method used.

Due to Average measurements being recorded, an additional Peak to Average measurement was made in all single carrier configurations. This was achieved using the CCDF function of the Spectrum Analyser with the RBW being set to a value wider than the largest signal being measured – in this case – 20MHz. A comparison was made with a wide band Power Meter capable of measuring Peak to Average ratio to confirm correlation with the method used.

In the case of MIMO operation, the power was measured from each antenna port and the results summed in accordance with FCC KDB 662911 D01.

2.1.6 Test Results

Configuration LTE-SC (See Table 1 for carrier frequency)

Maximum Output Power 46 dBm per carrier, Test Model 1.1

Antenna	Carrier Bandwidth (MHz)	Average Output Power / Peak to Average Ratio (PAR)					
		Channel Position B		Channel Position M		Channel Position T	
		Power (dBm)	PAR (dB)	Power (dBm)	PAR (dB)	Power (dBm)	PAR (dB)
A	5.0 MHz	45.86	7.39	46.05	7.38	45.90	7.35
B		45.32	7.43	45.79	7.34	45.79	7.31
C		45.34	7.38	45.77	7.35	45.72	7.32
D		45.67	7.38	46.10	7.36	46.00	7.32
Total		51.58	-	51.95	-	51.88	-
A	10.0 MHz	45.86	7.65	46.07	7.40	45.96	7.38
B		45.39	7.63	45.77	7.38	45.84	7.36
C		45.41	7.62	45.77	7.39	45.82	7.36
D		45.74	7.61	45.99	7.39	45.96	7.36
Total		51.62	-	51.92	-	51.92	-
A	15.0 MHz	45.89	7.99	45.99	7.35	45.87	7.51
B		45.43	7.93	45.76	7.38	45.78	7.52
C		45.47	7.98	45.76	7.36	45.79	7.52
D		45.71	7.99	45.90	7.37	45.91	7.52
Total		51.65	-	51.87	-	51.86	-
A	20.0 MHz	45.78	8.18	45.99	7.50	46.06	7.67
B		45.34	8.20	45.72	7.50	45.81	7.64
C		45.40	8.20	45.73	7.51	45.82	7.62
D		45.65	8.15	45.90	7.51	45.91	7.66
Total		51.57	-	51.86	-	51.92	-

Channel Position B - Bandwidth 5.0 MHz - Antenna Port A

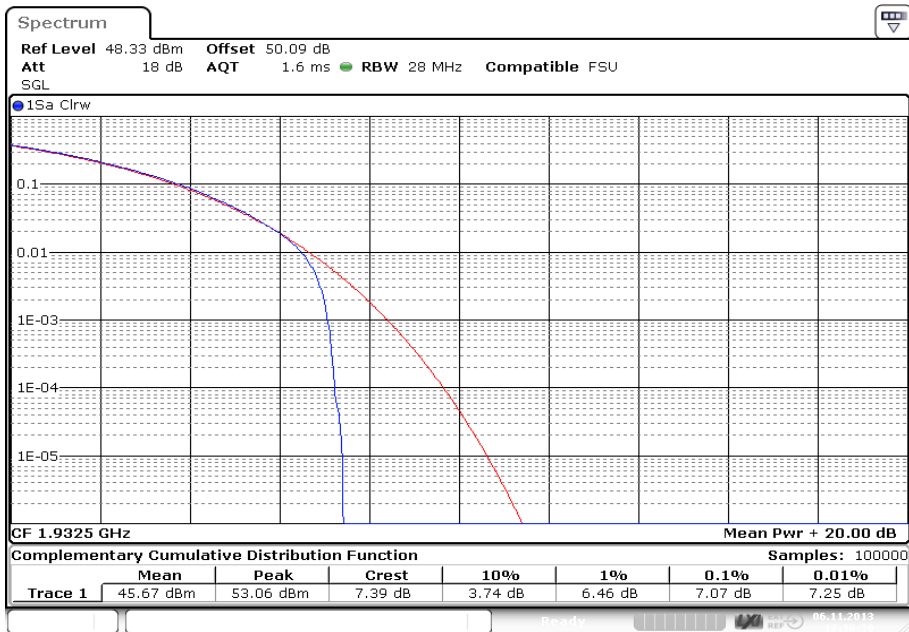

Date: 6.NOV.2013 17:36:39

Channel Position B - Bandwidth 5.0 MHz - Antenna Port B

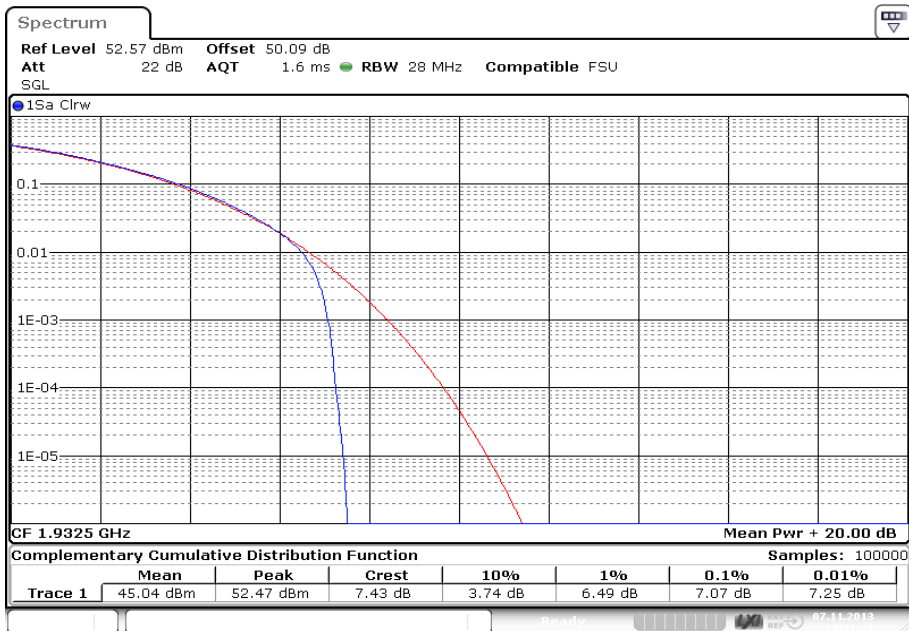

Date: 7.NOV.2013 14:31:23

Channel Position B - Bandwidth 5.0 MHz - Antenna Port C

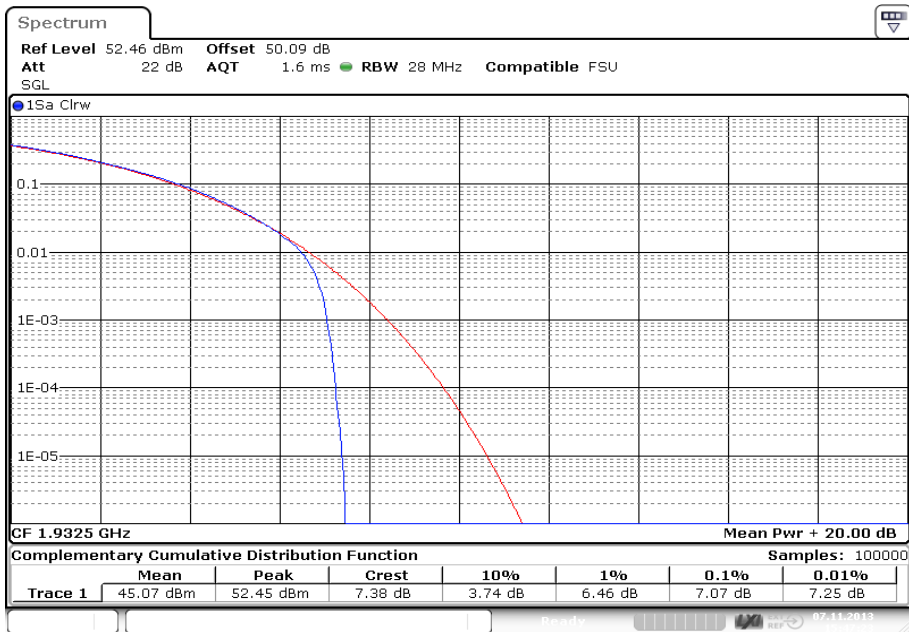

Date: 7.NOV.2013 15:47:23

Channel Position B - Bandwidth 5.0 MHz - Antenna Port D

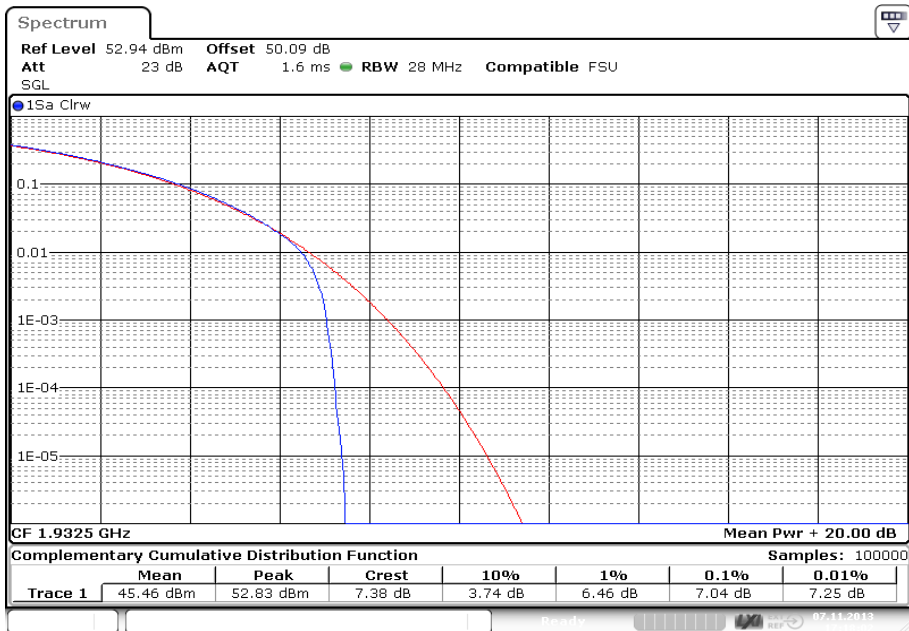

Date: 7.NOV.2013 17:18:03

Channel Position B - Bandwidth 10.0 MHz - Antenna Port A

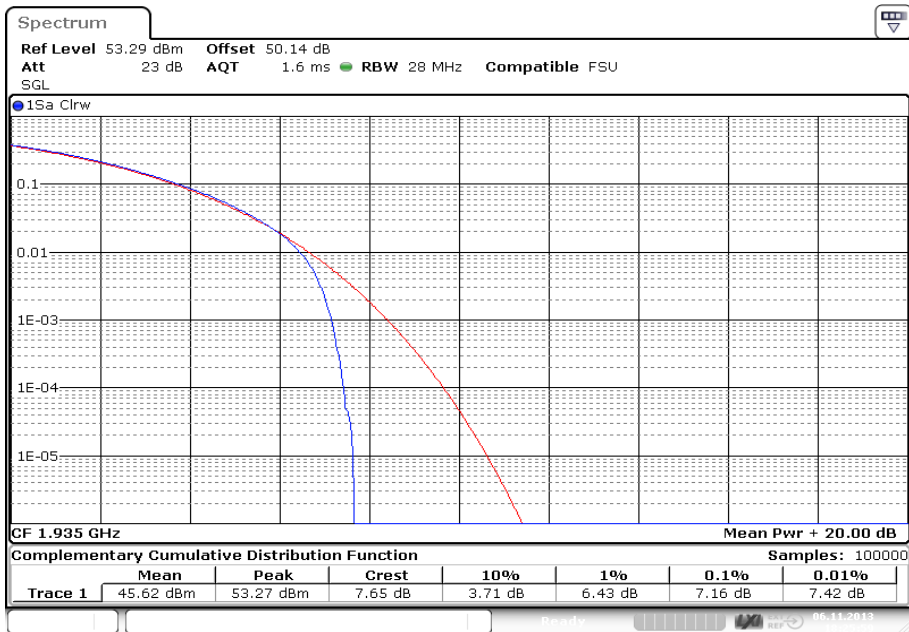

Channel Position B - Bandwidth 10.0 MHz - Antenna Port B

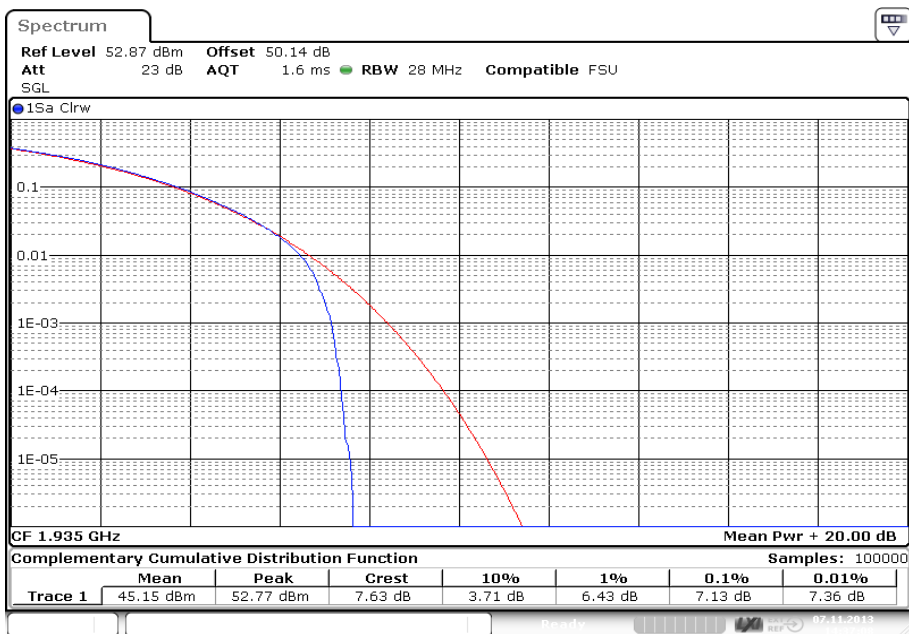

Channel Position B - Bandwidth 10.0 MHz - Antenna Port C

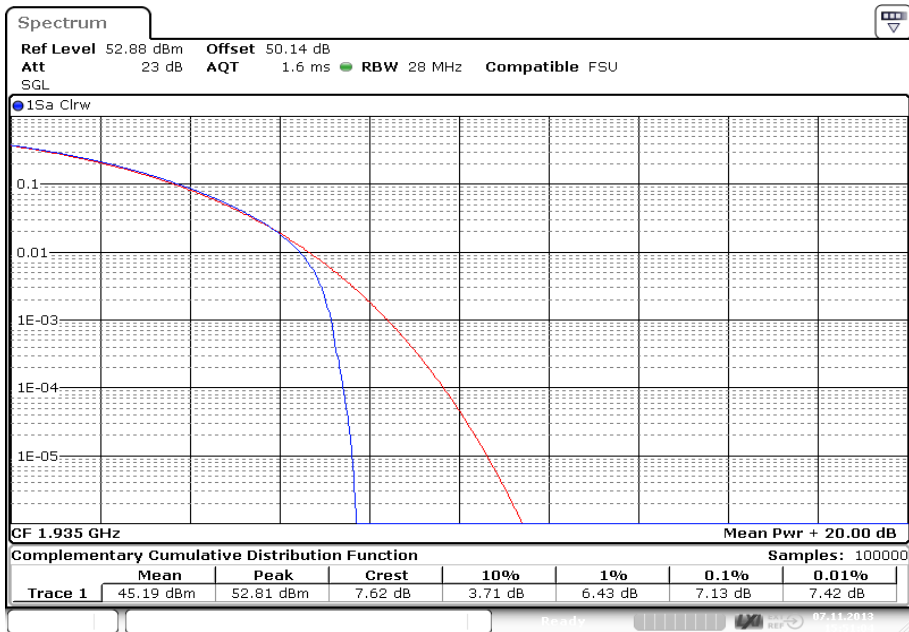

Channel Position B - Bandwidth 10.0 MHz - Antenna Port D

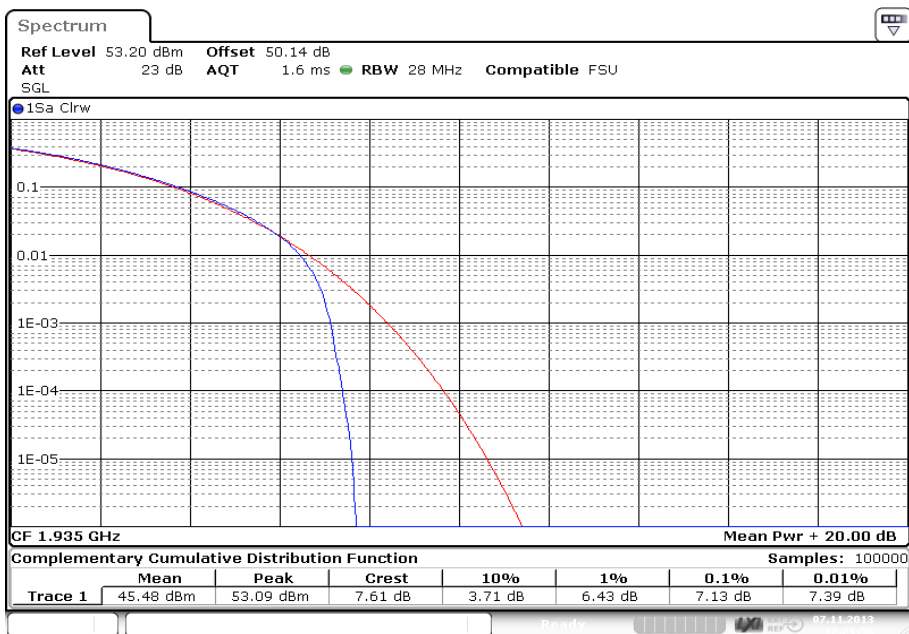

Channel Position B - Bandwidth 15.0 MHz - Antenna Port A

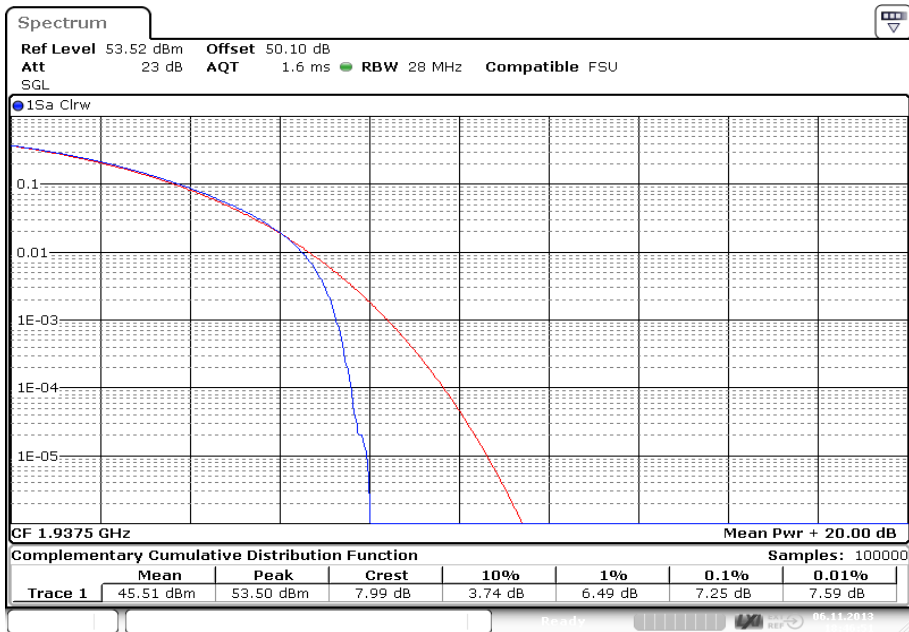

Channel Position B - Bandwidth 15.0 MHz - Antenna Port B

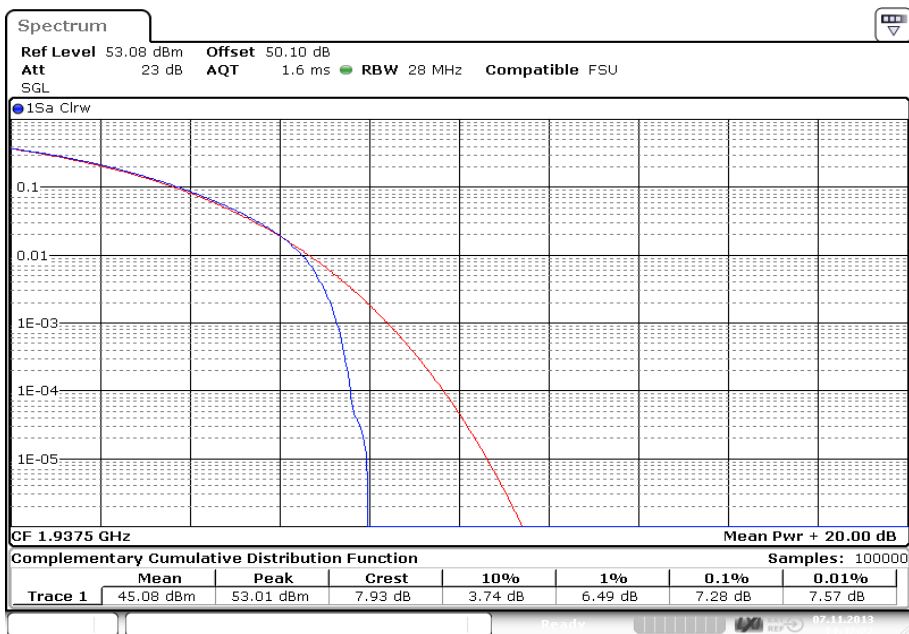

Channel Position B - Bandwidth 15.0 MHz - Antenna Port C

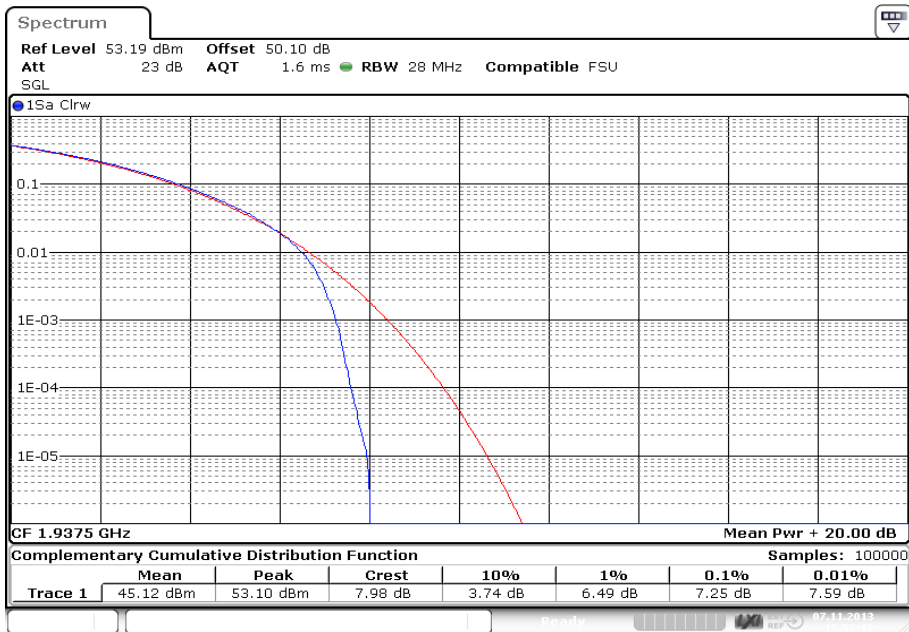

Date: 7.NOV.2013 15:55:12

Channel Position B - Bandwidth 15.0 MHz - Antenna Port D

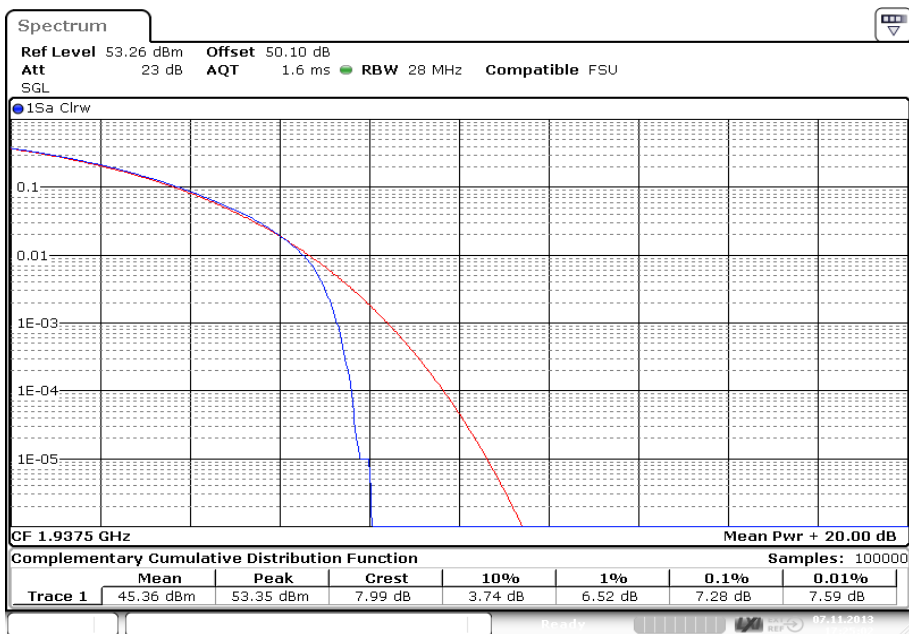

Date: 7.NOV.2013 17:25:02

Channel Position B - Bandwidth 20.0 MHz - Antenna Port A

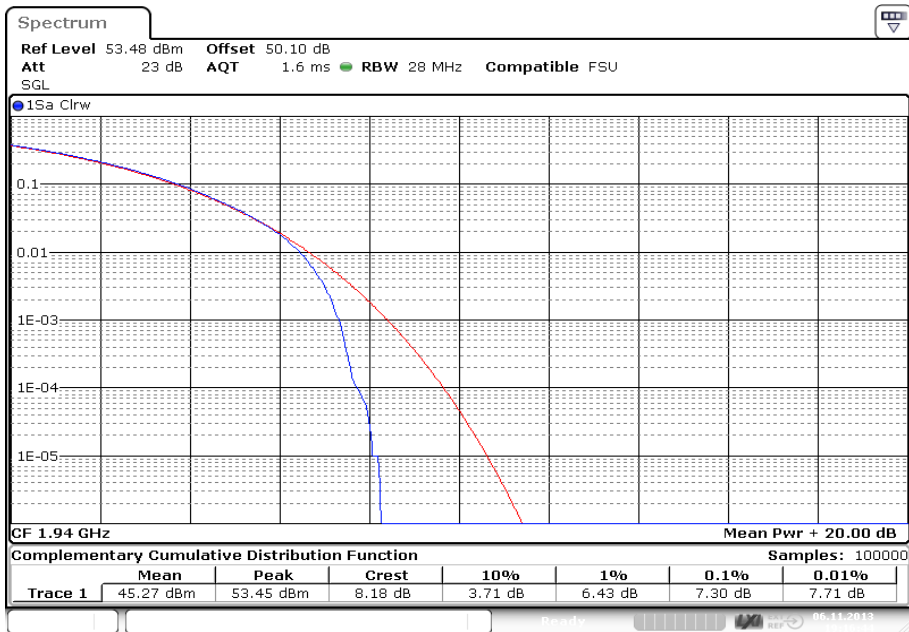

Channel Position B - Bandwidth 20.0 MHz - Antenna Port B

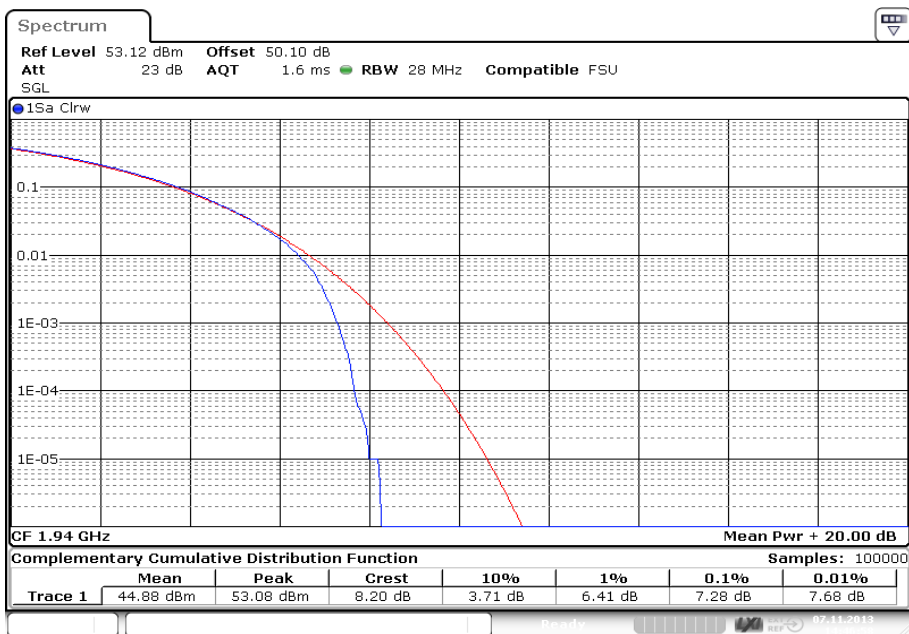

Channel Position B - Bandwidth 20.0 MHz - Antenna Port C

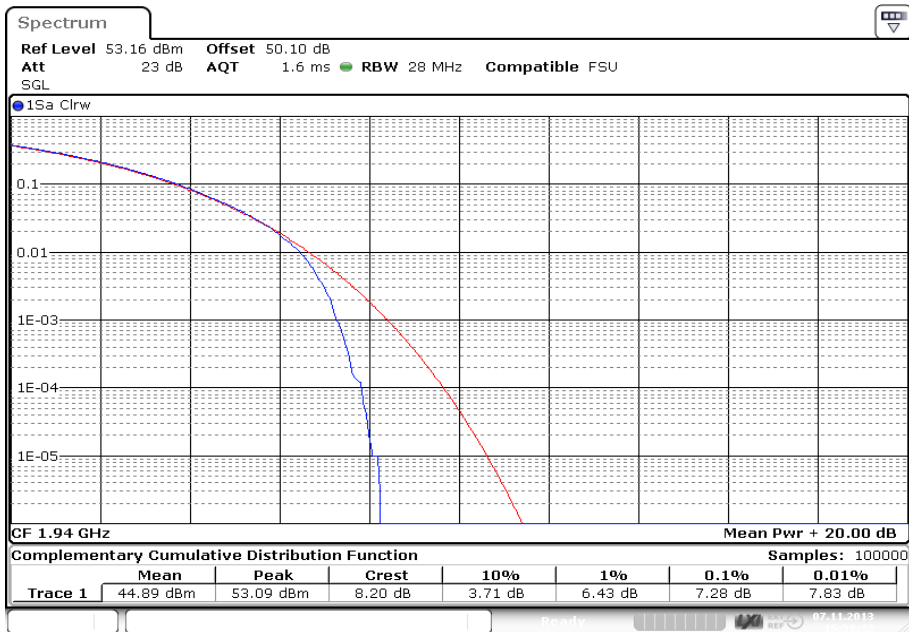

Date: 7.NOV.2013 15:59:33

Channel Position B - Bandwidth 20.0 MHz - Antenna Port D

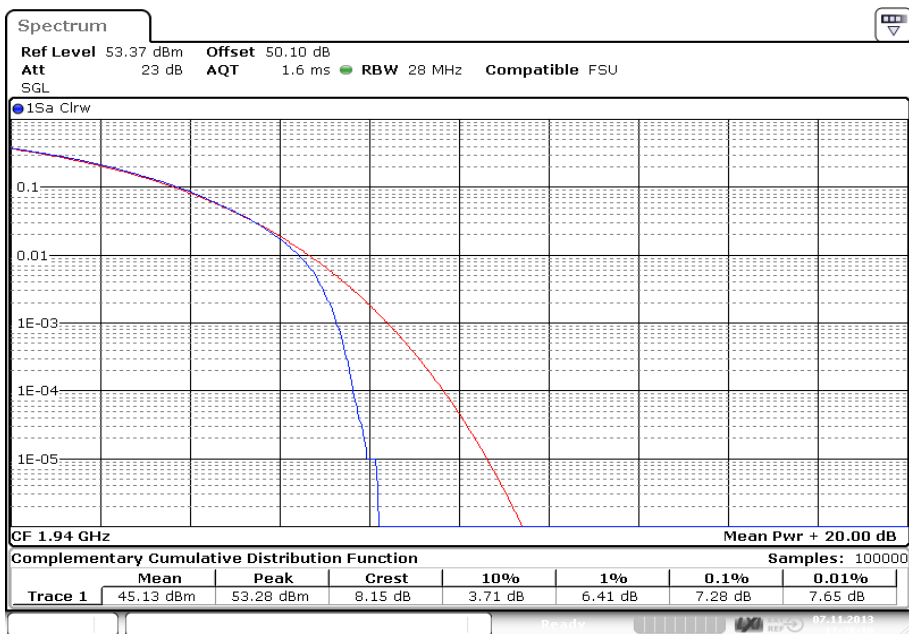

Date: 7.NOV.2013 17:28:11

Channel Position M - Bandwidth 5.0 MHz - Antenna Port A

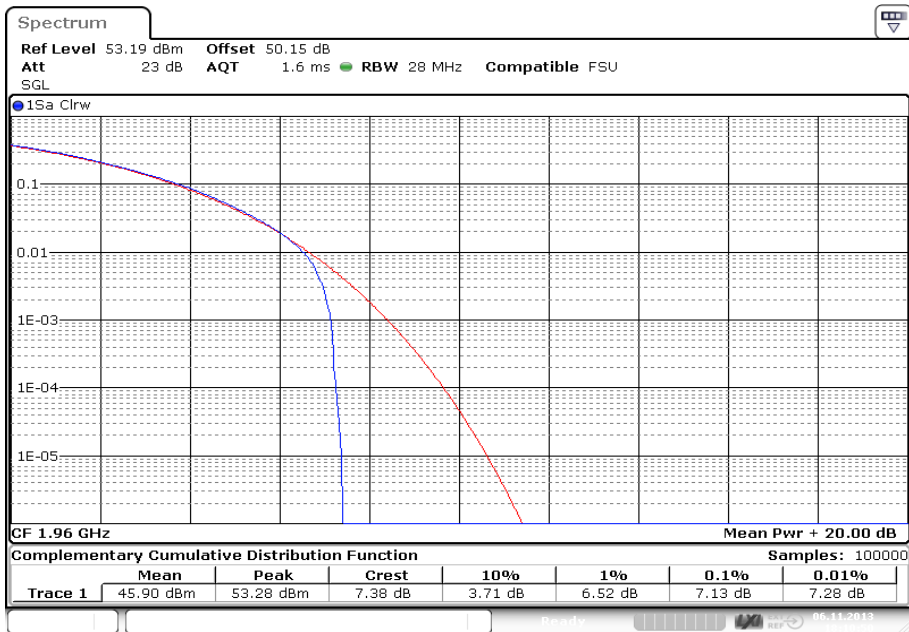

Channel Position M - Bandwidth 5.0 MHz - Antenna Port B

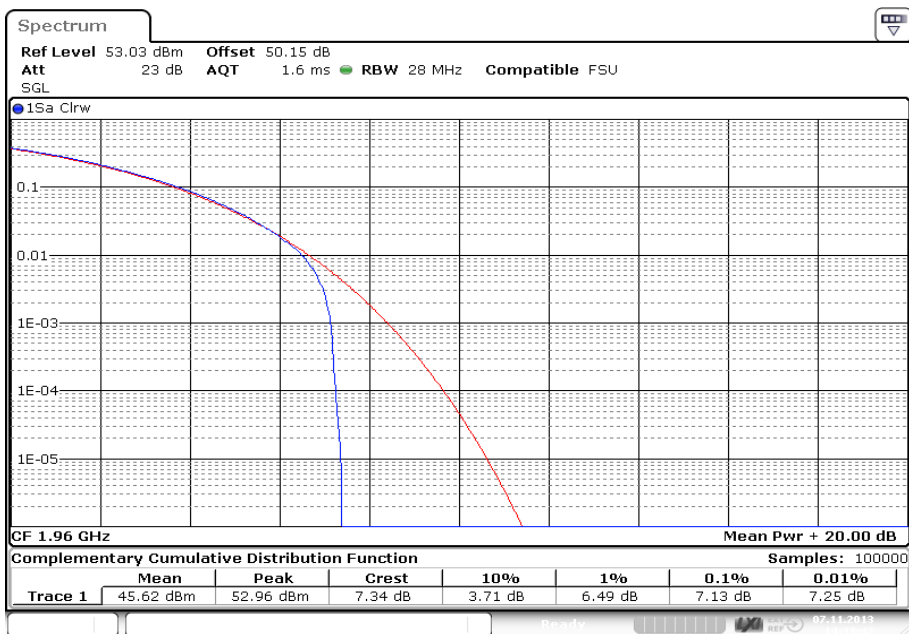

Channel Position M - Bandwidth 5.0 MHz - Antenna Port C

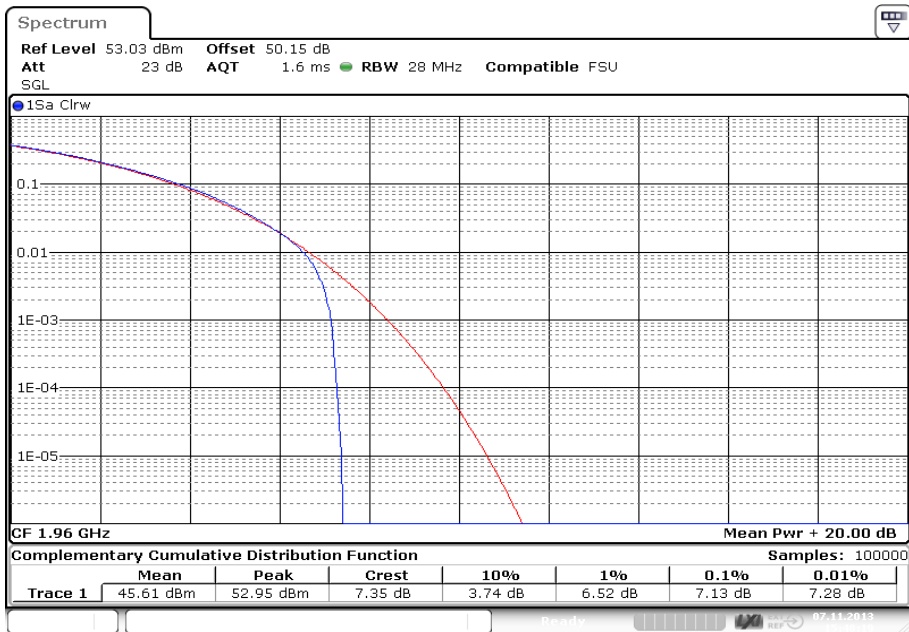

Date: 7.NOV.2013 15:48:20

Channel Position M - Bandwidth 5.0 MHz - Antenna Port D

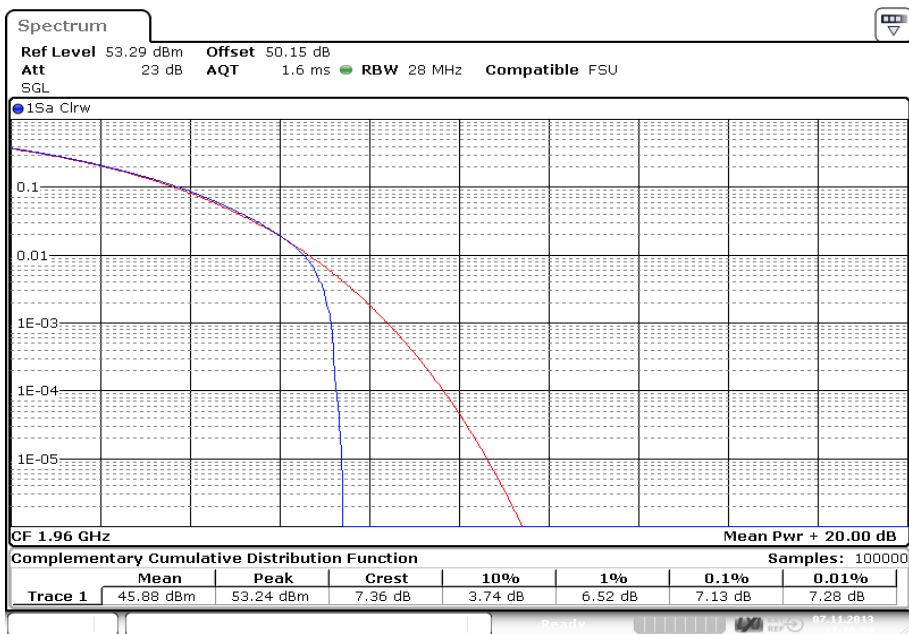

Date: 7.NOV.2013 17:19:09

Channel Position M - Bandwidth 10.0 MHz - Antenna Port A

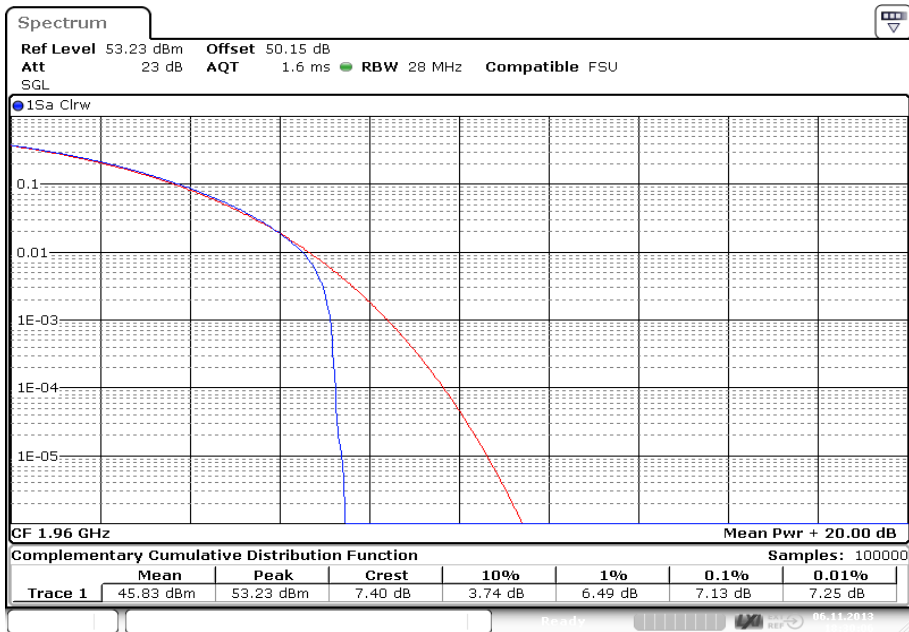

Channel Position M - Bandwidth 10.0 MHz - Antenna Port B

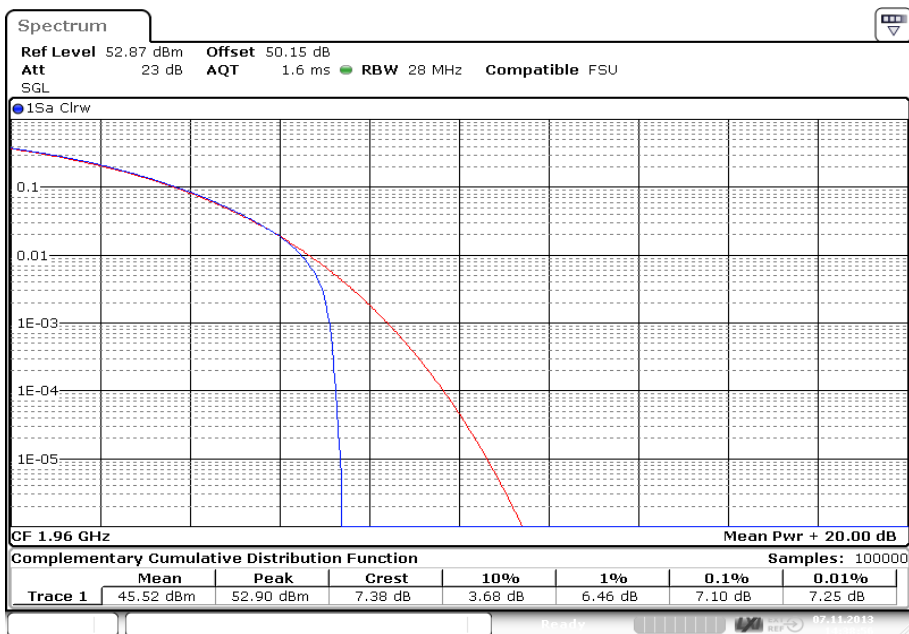

Channel Position M - Bandwidth 10.0 MHz - Antenna Port C

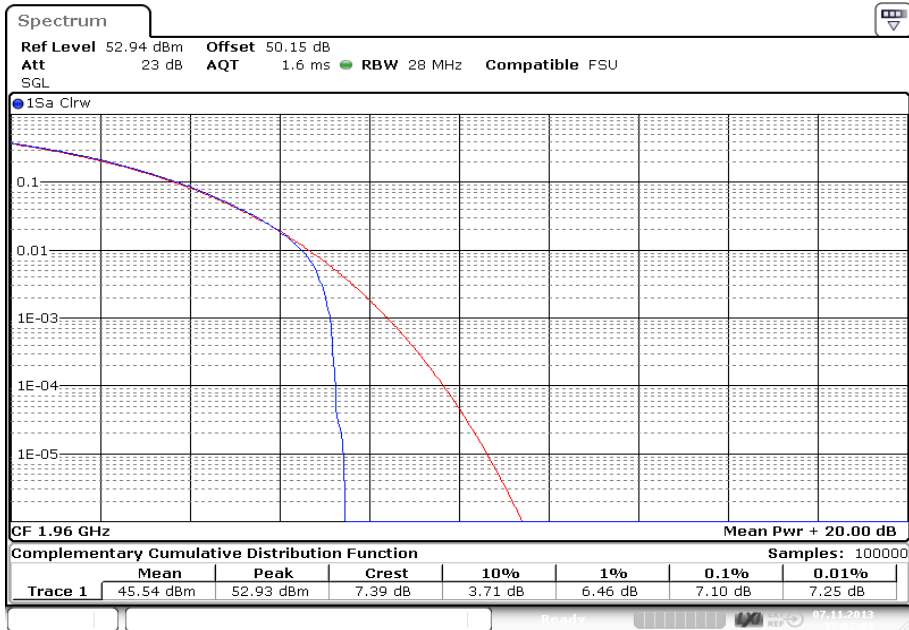

Channel Position M - Bandwidth 10.0 MHz - Antenna Port D

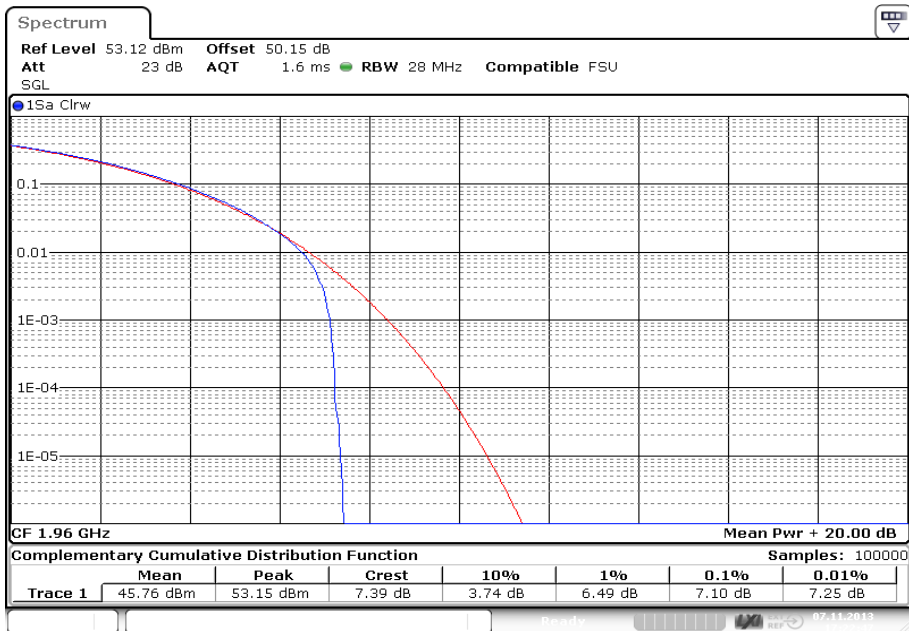

Channel Position M - Bandwidth 15.0 MHz - Antenna Port A

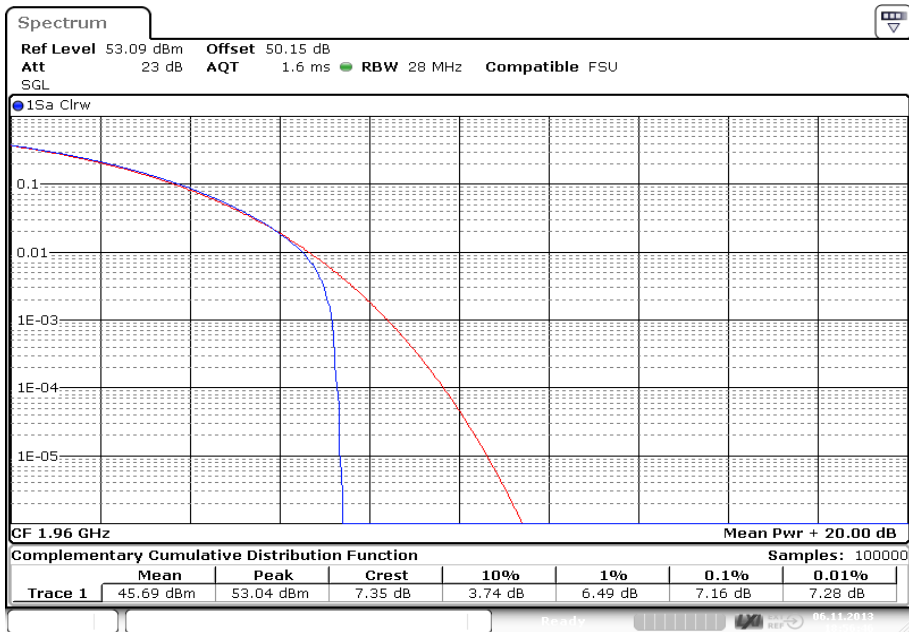

Date: 6.NOV.2013 18:56:47

Channel Position M - Bandwidth 15.0 MHz - Antenna Port B

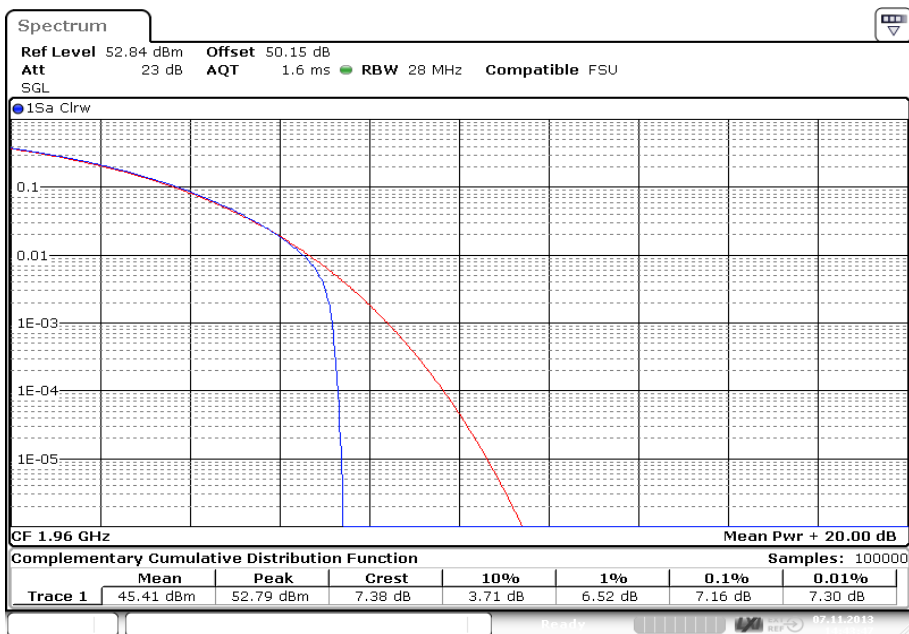

Date: 7.NOV.2013 14:43:48

Channel Position M - Bandwidth 15.0 MHz - Antenna Port C



Date: 7.NOV.2013 15:56:36

Channel Position M - Bandwidth 15.0 MHz - Antenna Port D

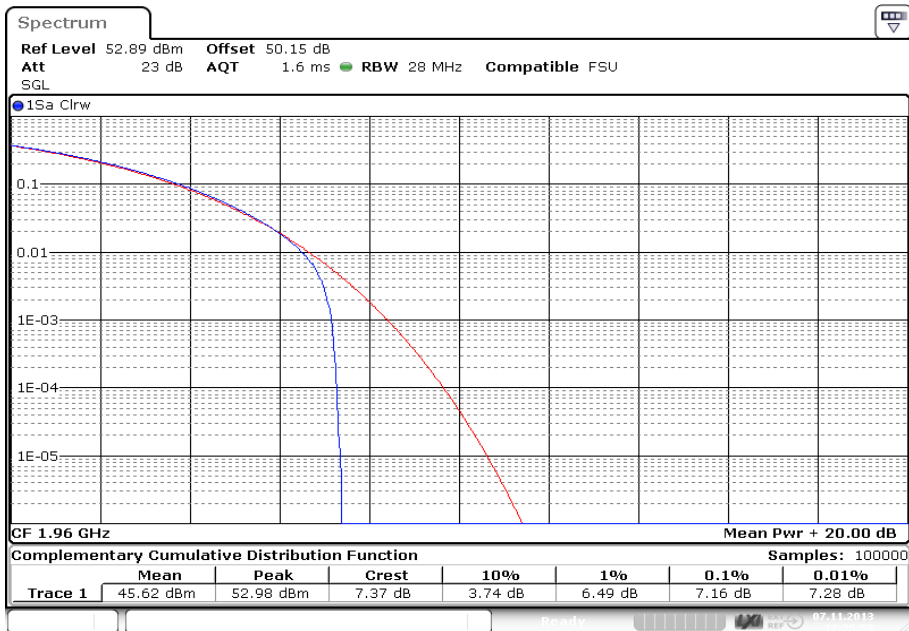

Date: 7.NOV.2013 17:25:58

Channel Position M - Bandwidth 20.0 MHz - Antenna Port A

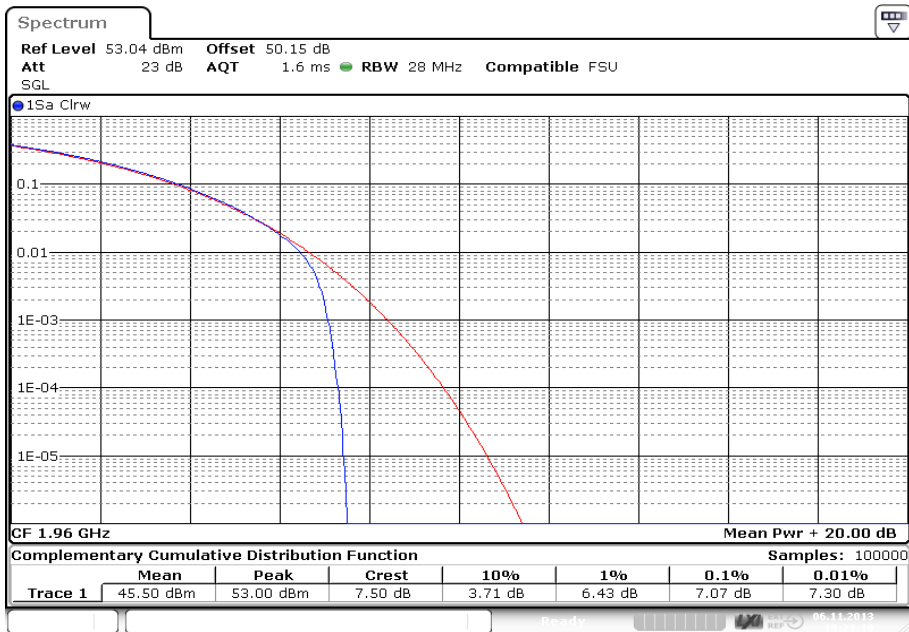

Channel Position M - Bandwidth 20.0 MHz - Antenna Port B

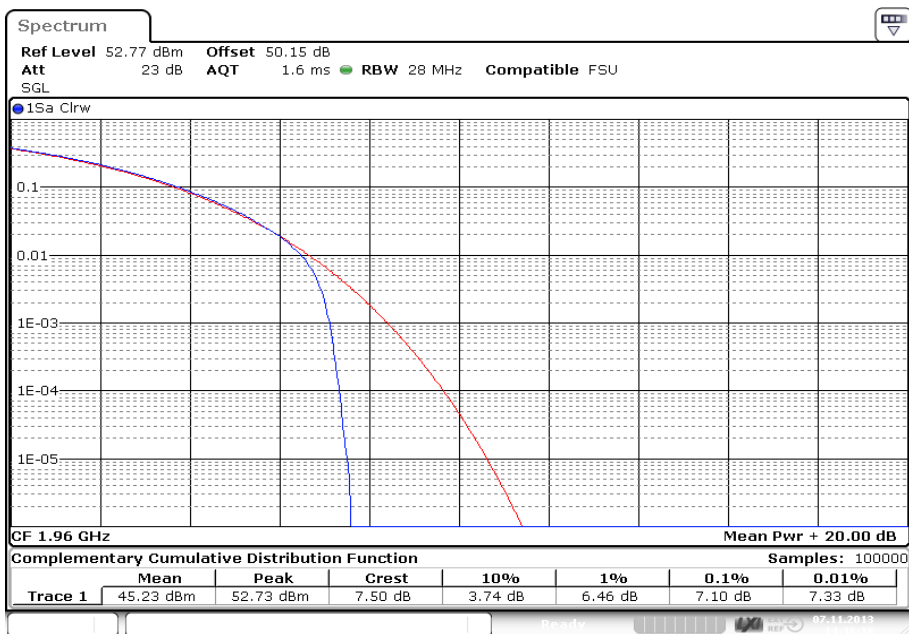

Channel Position M - Bandwidth 20.0 MHz - Antenna Port C

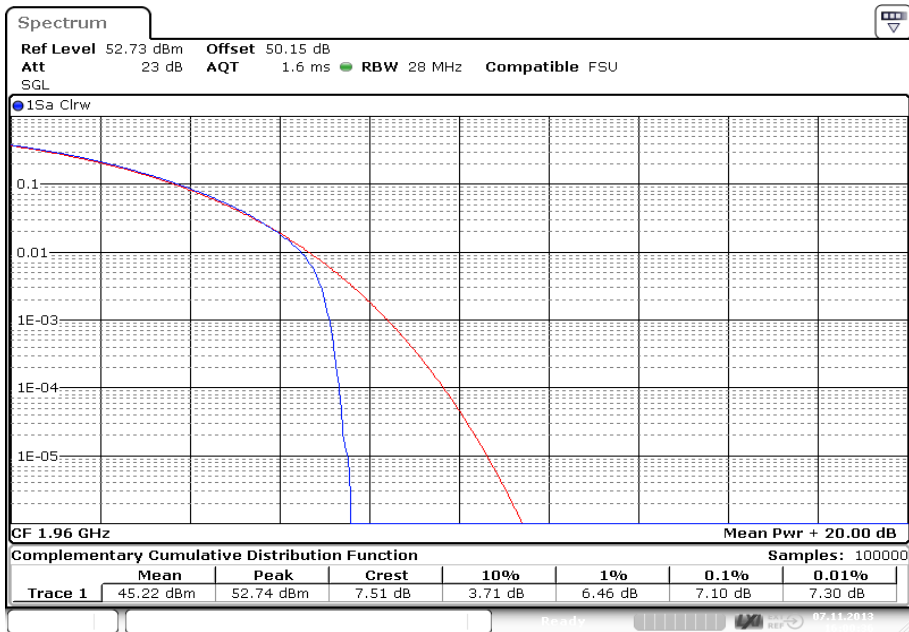

Date: 7.NOV.2013 16:00:36

Channel Position M - Bandwidth 20.0 MHz - Antenna Port D

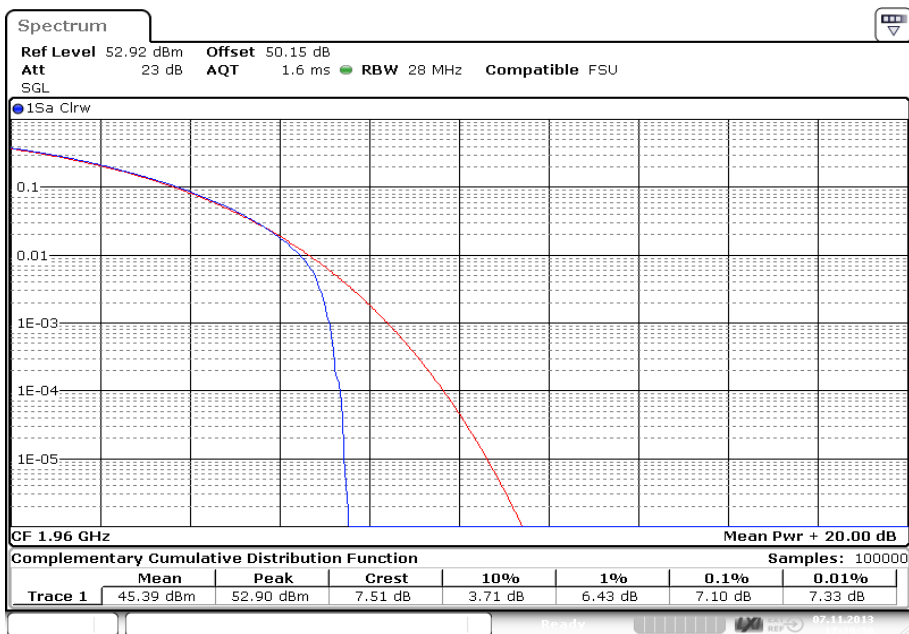

Date: 7.NOV.2013 17:29:30

Channel Position T - Bandwidth 5.0 MHz - Antenna Port A

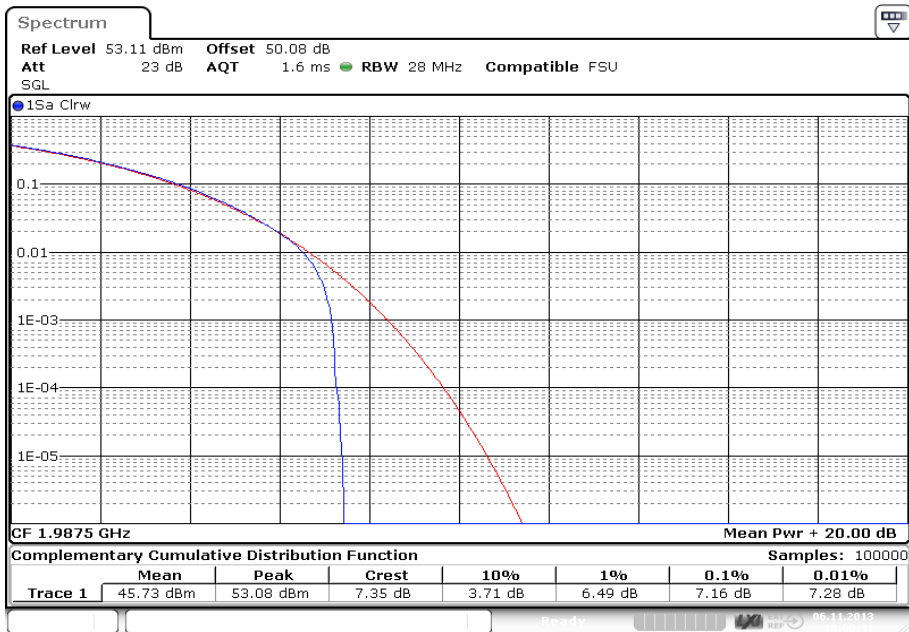

Date: 6.NOV.2013 18:09:42

Channel Position T - Bandwidth 5.0 MHz - Antenna Port B

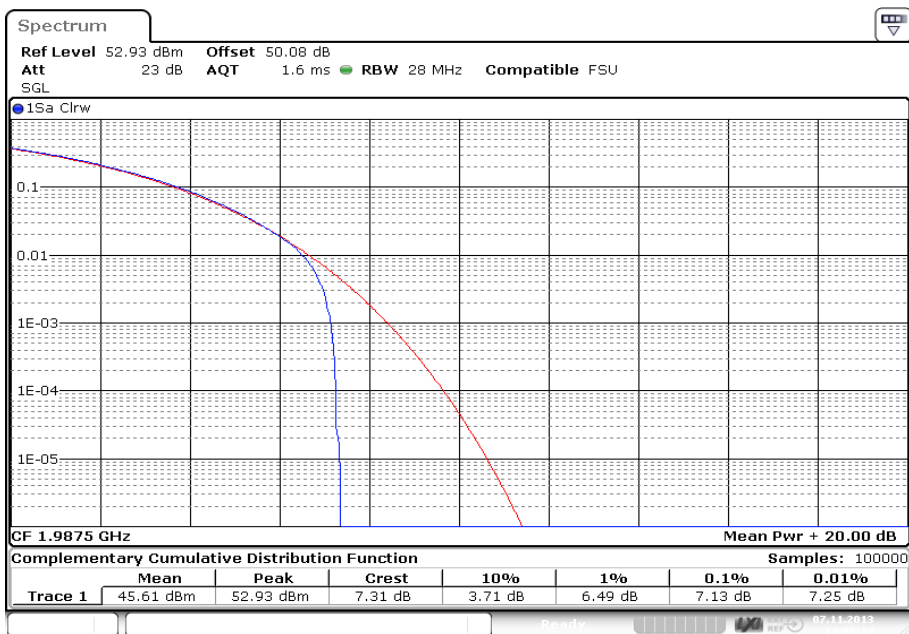

Date: 7.NOV.2013 14:35:15

Channel Position T - Bandwidth 5.0 MHz - Antenna Port C

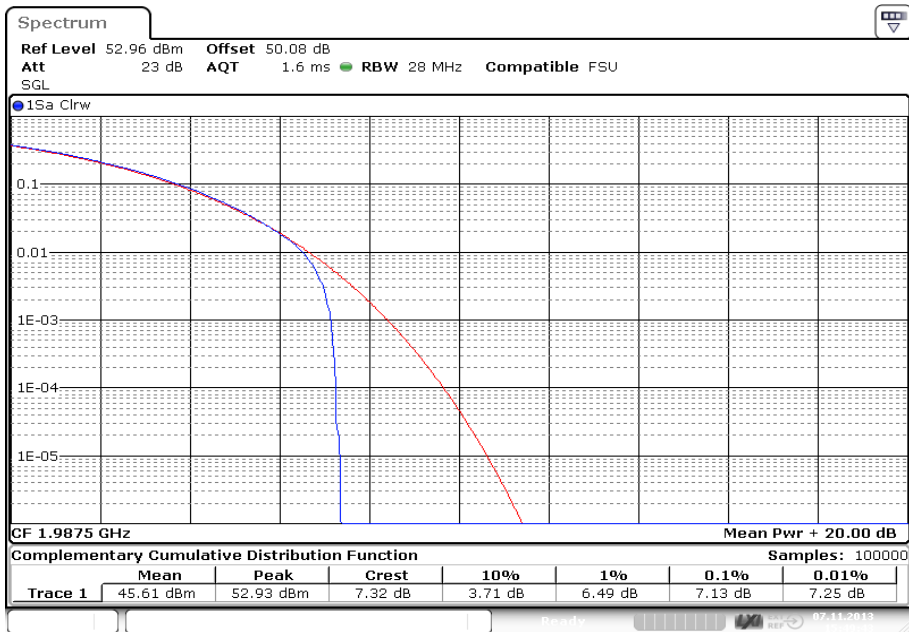

Date: 7.NOV.2013 15:49:43

Channel Position T - Bandwidth 5.0 MHz - Antenna Port D

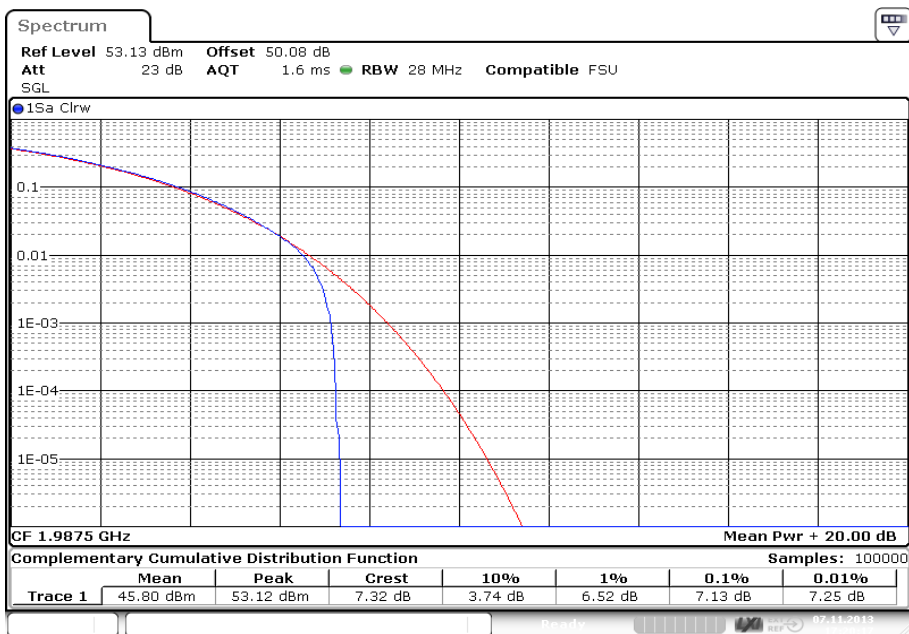

Date: 7.NOV.2013 17:20:17

Channel Position T - Bandwidth 10.0 MHz - Antenna Port A

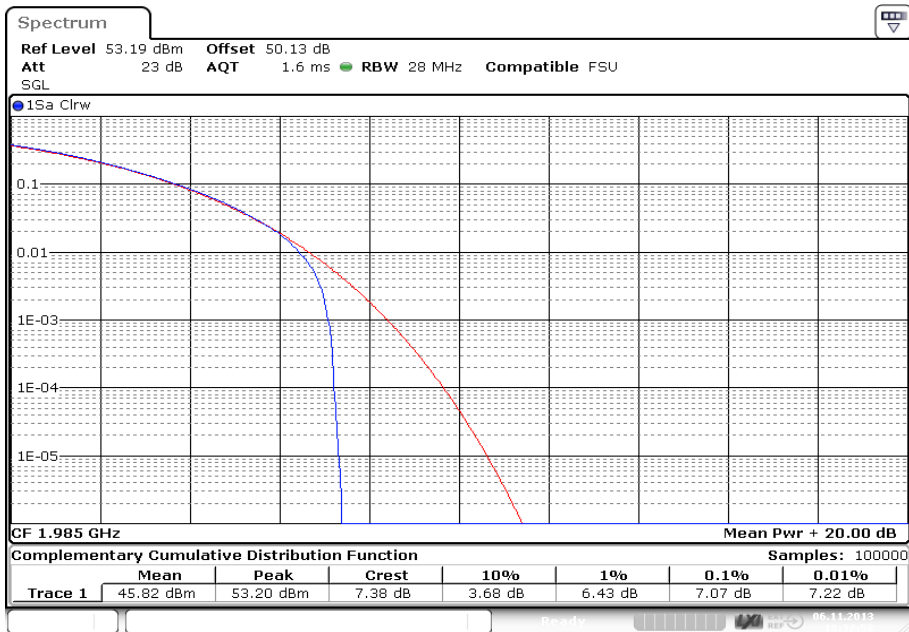

Date: 6.NOV.2013 18:32:58

Channel Position T - Bandwidth 10.0 MHz - Antenna Port B

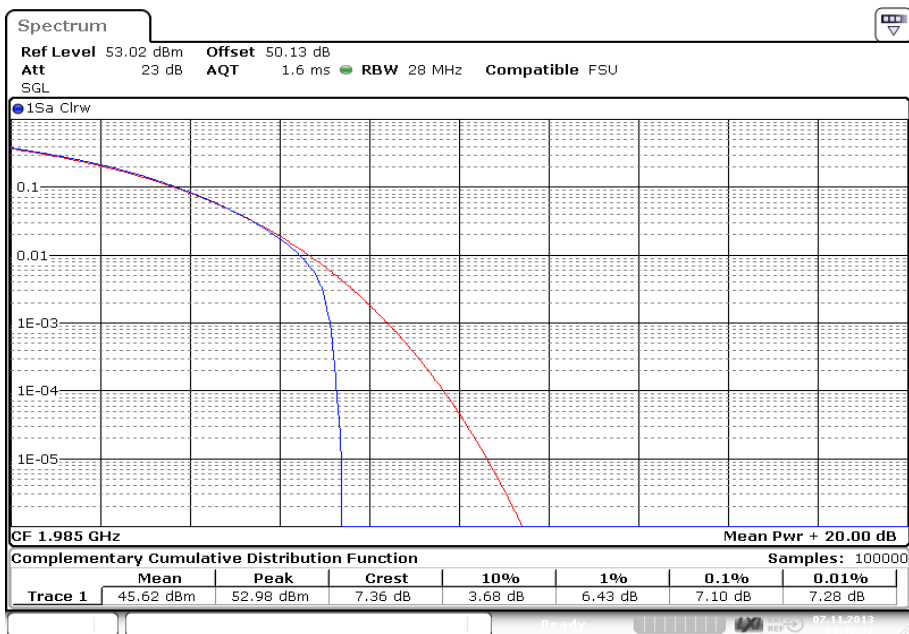

Date: 7.NOV.2013 14:40:27

Channel Position T - Bandwidth 10.0 MHz - Antenna Port C

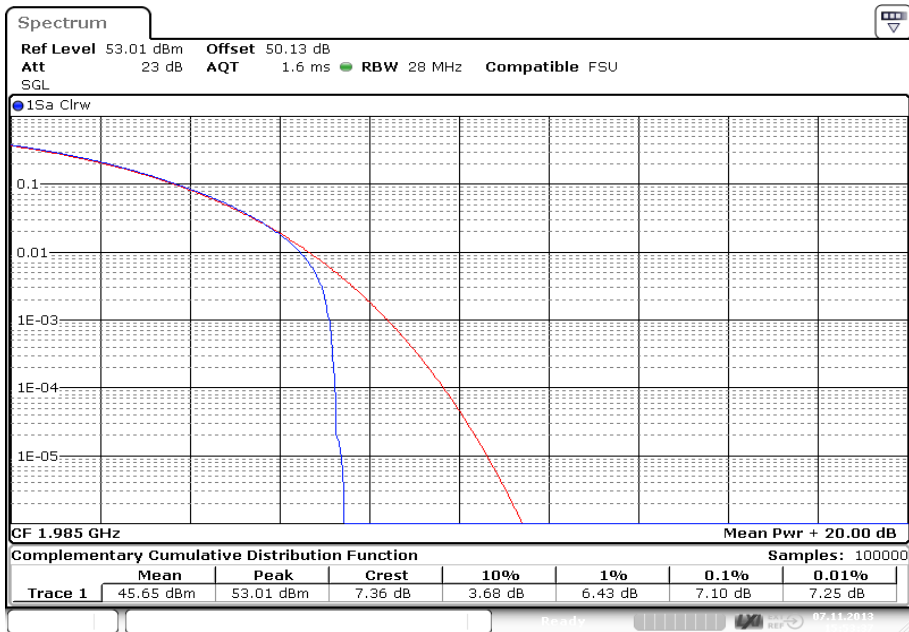

Channel Position T - Bandwidth 10.0 MHz - Antenna Port D

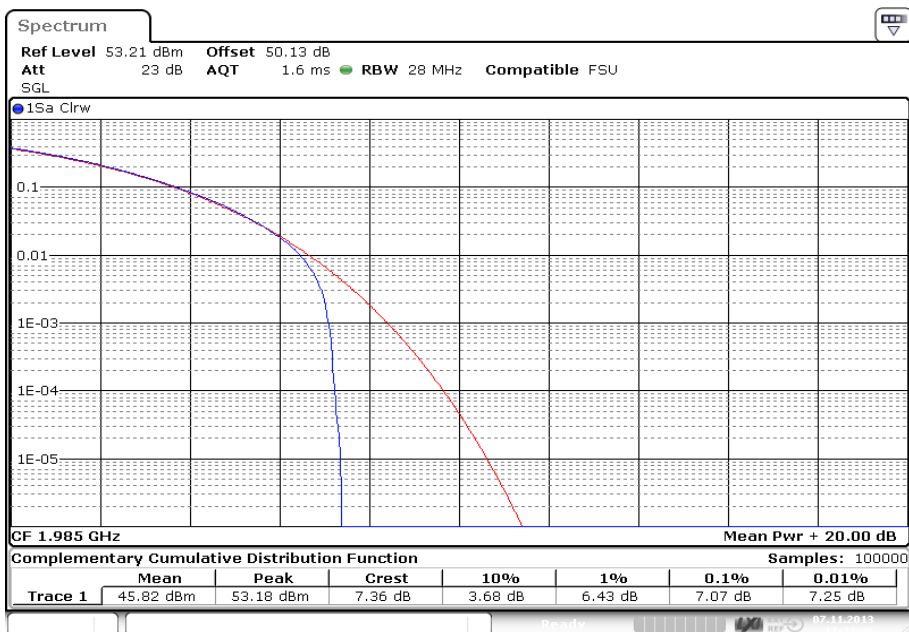

Channel Position T - Bandwidth 15.0 MHz - Antenna Port A

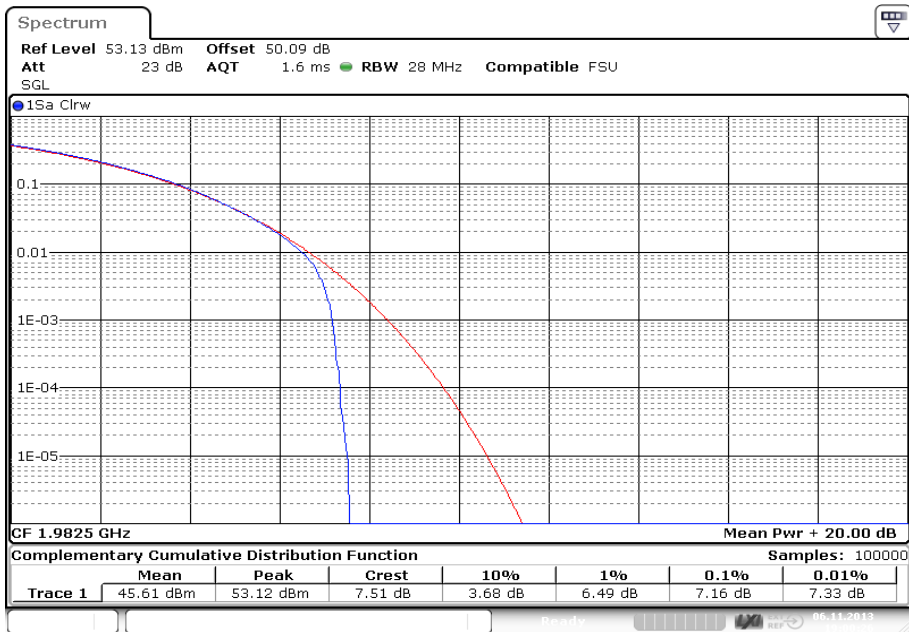

Date: 6.NOV.2013 19:00:27

Channel Position T - Bandwidth 15.0 MHz - Antenna Port B

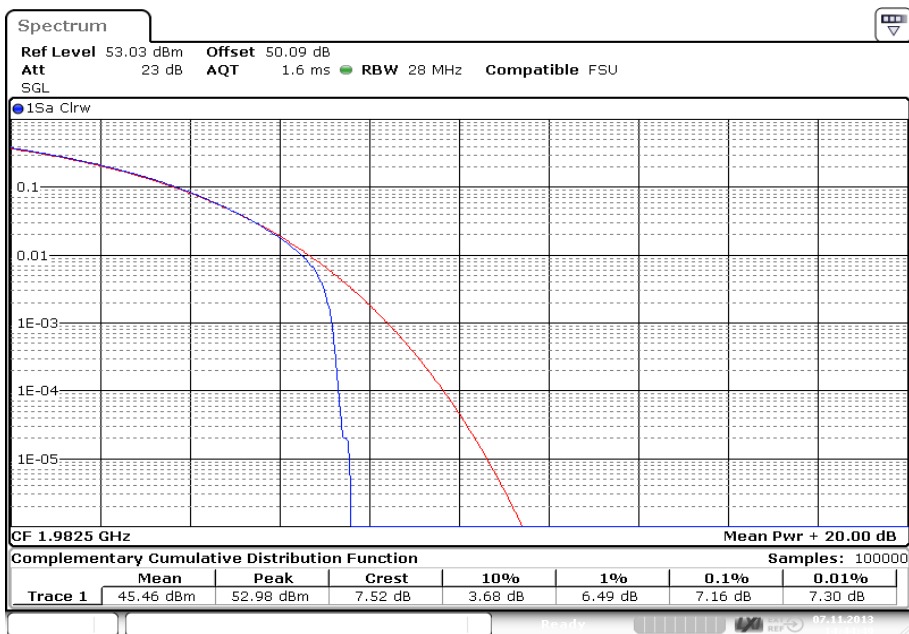

Date: 7.NOV.2013 14:44:50

Channel Position T - Bandwidth 15.0 MHz - Antenna Port C

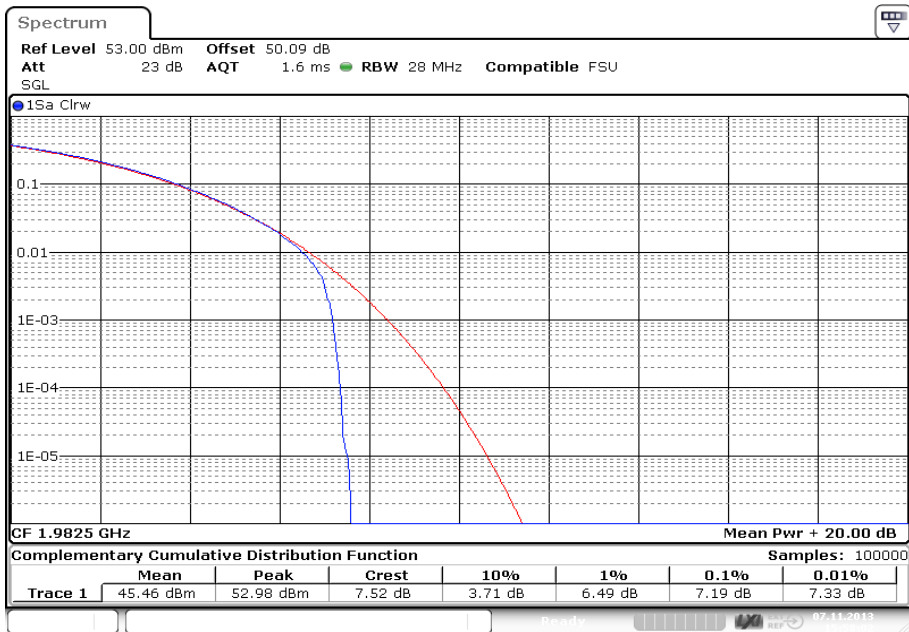

Channel Position T - Bandwidth 15.0 MHz - Antenna Port D

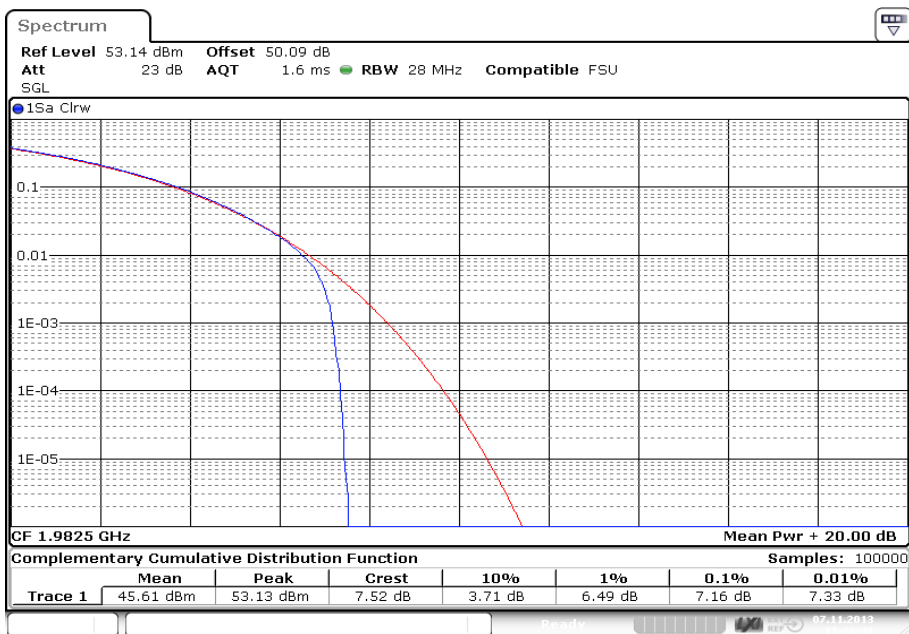

Channel Position T - Bandwidth 20.0 MHz - Antenna Port A

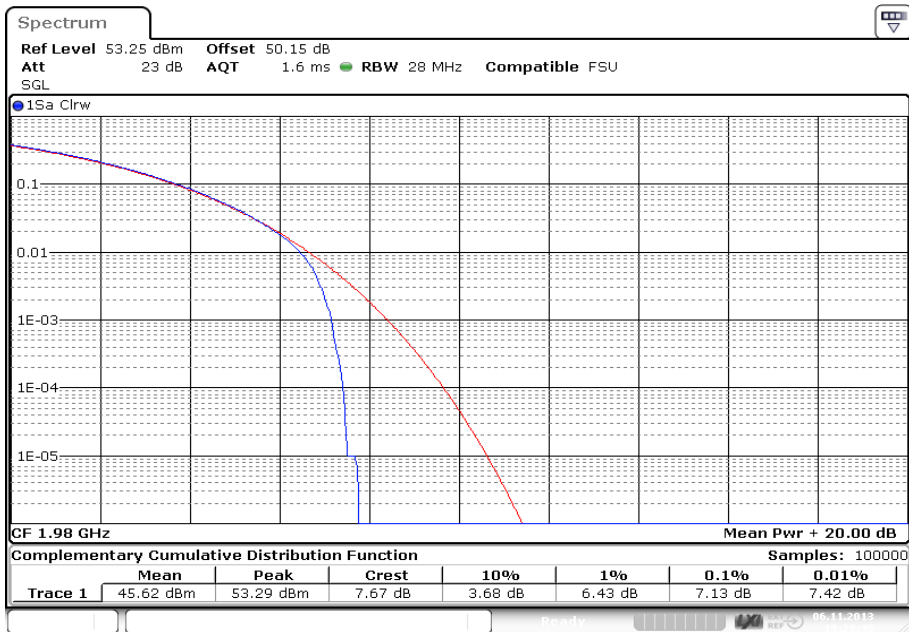

Date: 6.NOV.2013 19:29:36

Channel Position T - Bandwidth 20.0 MHz - Antenna Port B

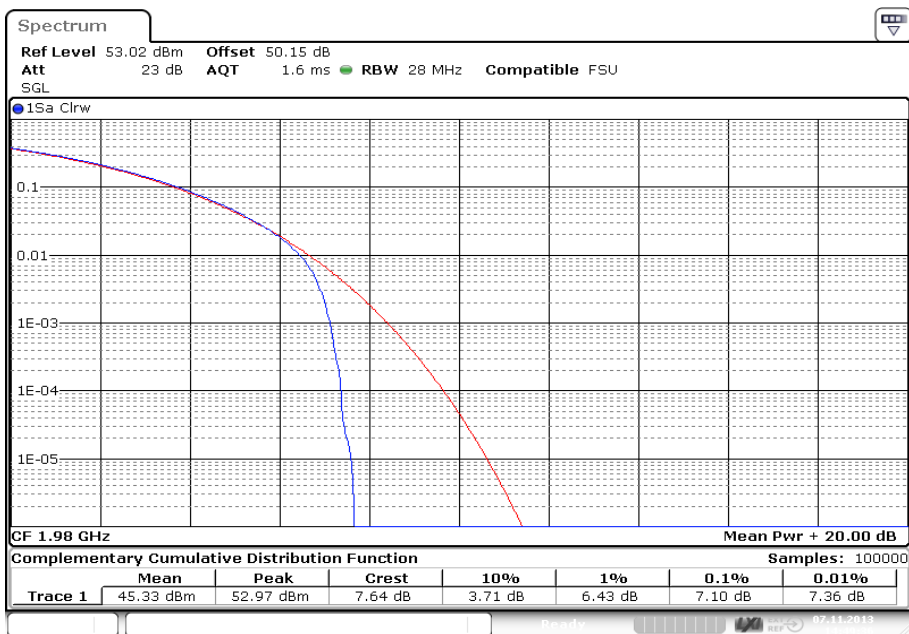

Date: 7.NOV.2013 14:49:36

Channel Position T - Bandwidth 20.0 MHz - Antenna Port C

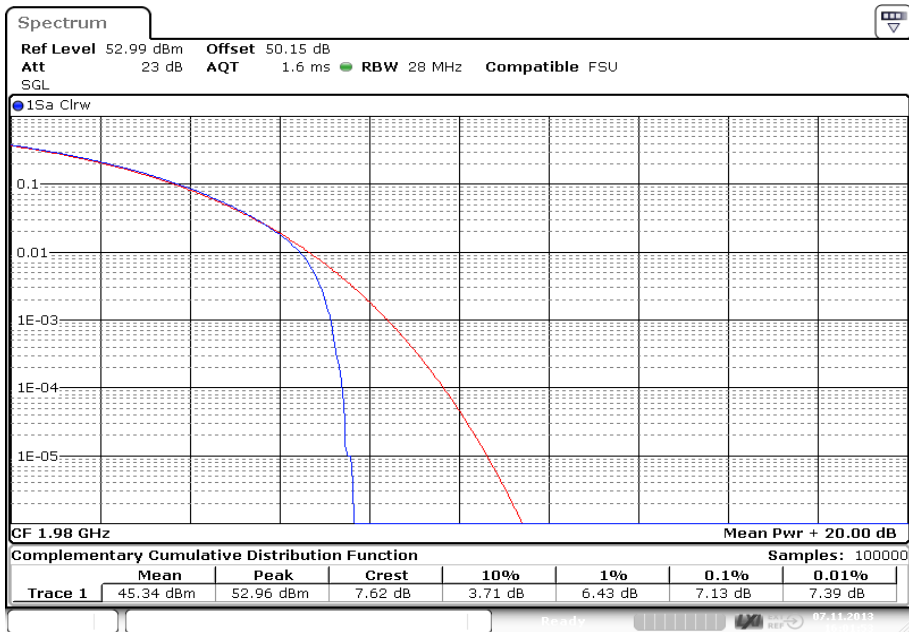

Date: 7.NOV.2013 16:01:53

Channel Position T - Bandwidth 20.0 MHz - Antenna Port D

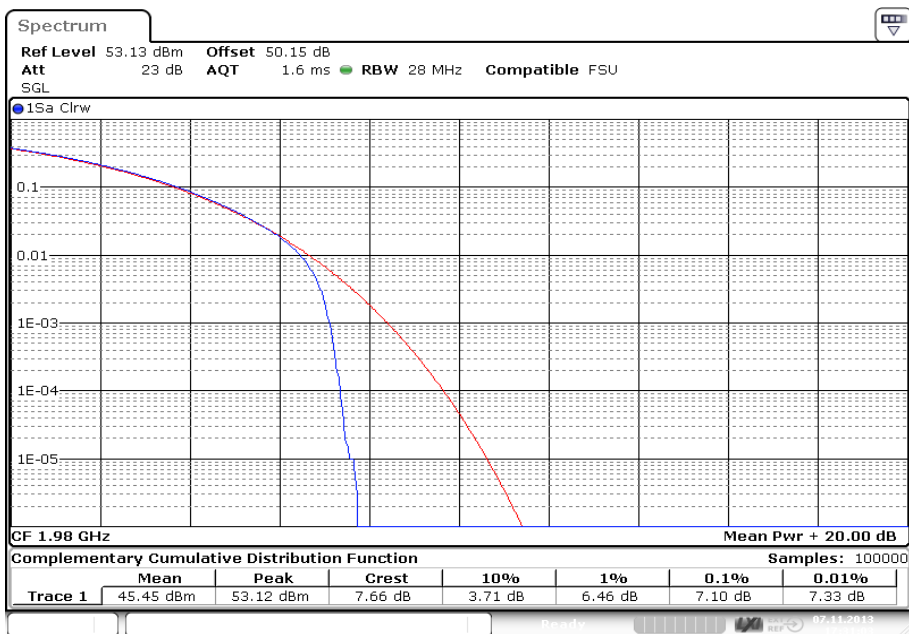

Date: 7.NOV.2013 17:31:03

Configuration LTE-MC1 (See Table 1 for carrier frequency)

Maximum Output Power 43 dBm per carrier, Test Model 1.1

Antenna	Carrier Bandwidth (MHz)	Average Output Power (dBm)		
		Channel Position B	Channel Position M	Channel Position T
A	5.0 MHz	-	45.66	-
B		-	45.55	-
C		-	45.59	-
B		-	45.77	-
Total		-	51.67	-
A	10.0 MHz	-	45.68	-
B		-	45.57	-
C		-	45.60	-
B		-	45.73	-
Total		-	51.67	-
A	15.0 MHz	-	45.72	-
B		-	45.59	-
C		-	45.62	-
B		-	45.71	-
Total		-	51.68	-
A	20.0 MHz	-	45.67	-
B		-	45.53	-
C		-	45.56	-
B		-	45.61	-
Total		-	51.61	-

Configuration LTE-MC2 (See Table 1 for carrier frequency)

Maximum Output Power 40 dBm per carrier, Test Model 1.1

Antenna	Carrier Bandwidth (MHz)	Average Output Power (dBm)		
		Channel Position B	Channel Position M	Channel Position T
A	5.0 MHz	-	45.87	-
B		-	45.53	-
C		-	45.66	-
B		-	45.69	-
Total		-	51.71	-
A	10.0 MHz	-	45.81	-
B		-	45.51	-
C		-	45.66	-
B		-	45.75	-
Total		-	51.70	-

Configuration CDMA-SC (See Table 1 for carrier frequency)

Maximum Output Power 46 dBm per carrier

Modulation	Average Output Power / Peak to Average Ratio (PAR)					
	Channel Position B		Channel Position M		Channel Position T	
	Power (dBm)	PAR (dB)	Power (dBm)	PAR (dB)	Power (dBm)	PAR (dB)
QPSK	45.58	7.25	45.78	7.33	45.64	7.33
8-PSK	45.48	7.27	45.95	7.36	45.61	7.35
16-QAM	45.52	7.32	45.72	7.38	45.59	7.40

Channel Position B - Modulation QPSK

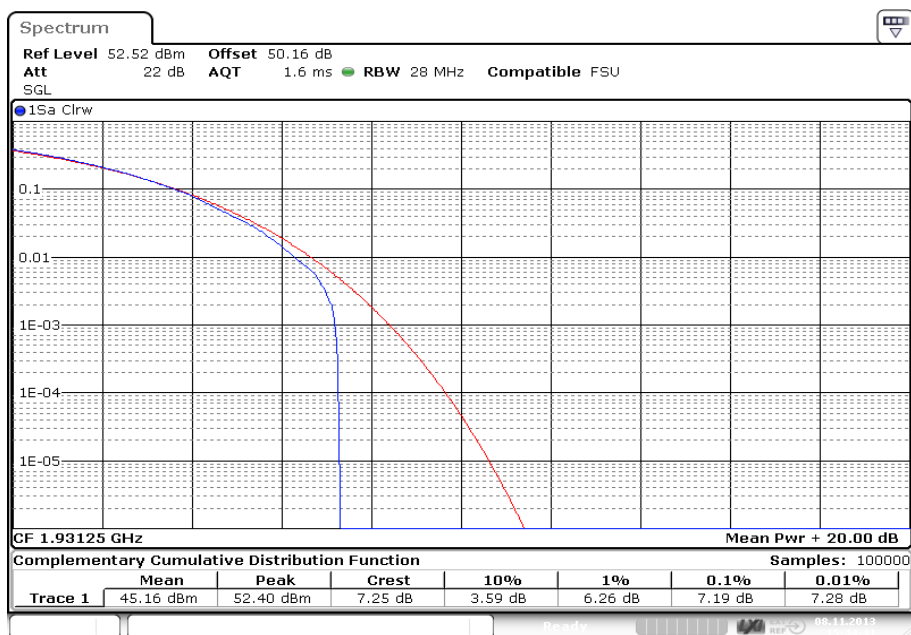

Date: 8.NOV.2013 15:44:42

Channel Position B - Modulation 8-PSK

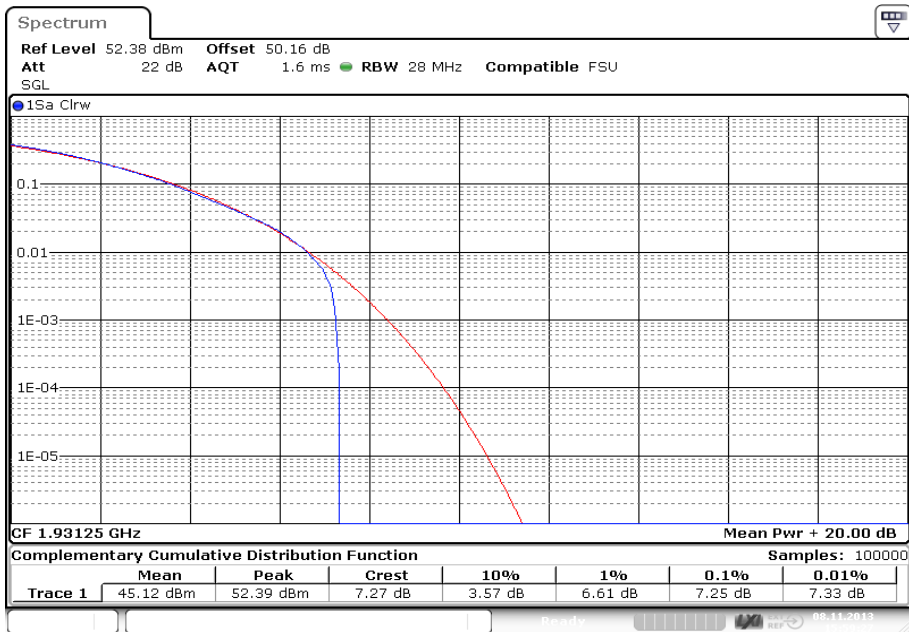

Channel Position B - Modulation 16-QAM

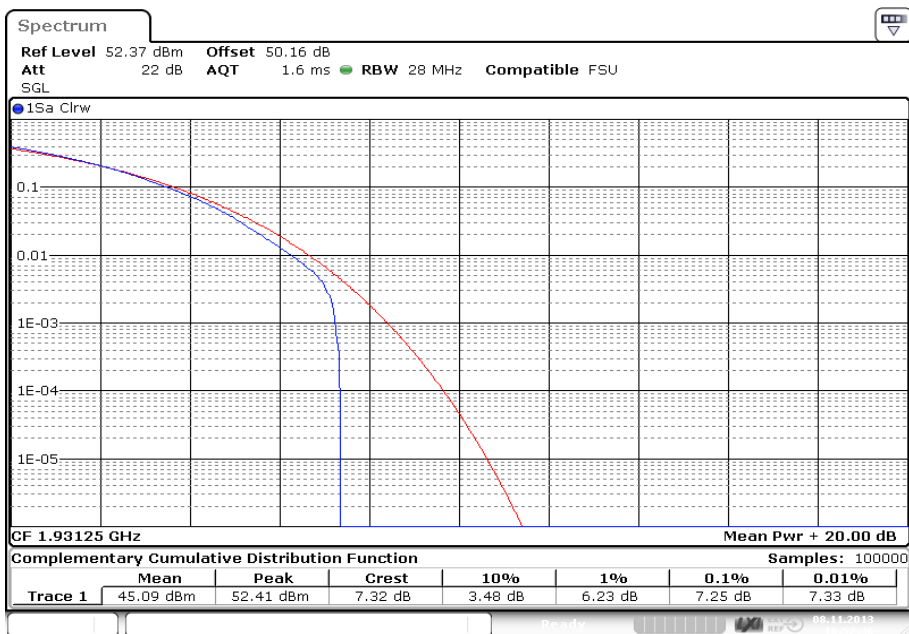

Channel Position M - Modulation QPSK

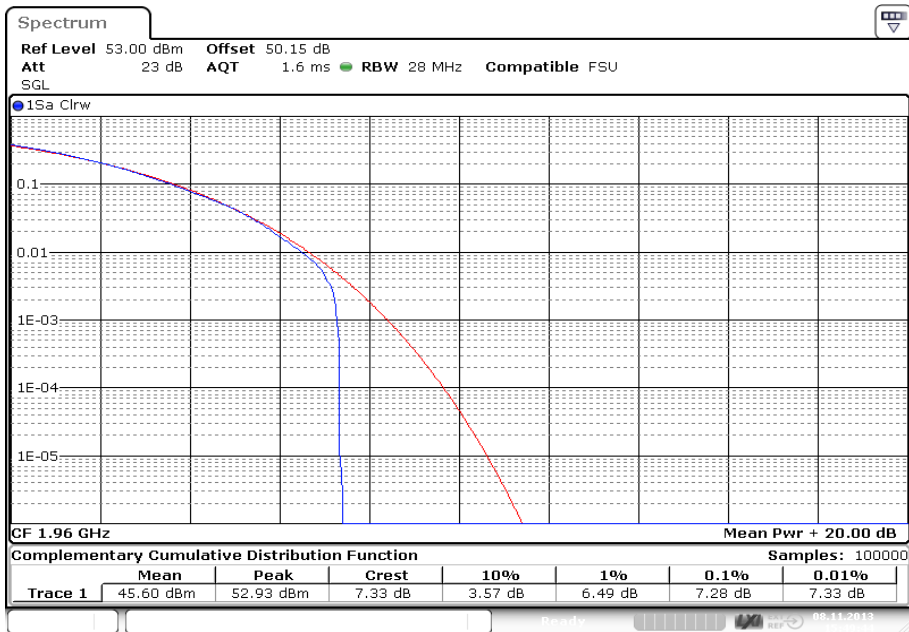

Date: 8.NOV.2013 15:49:45

Channel Position M - Modulation 8-PSK

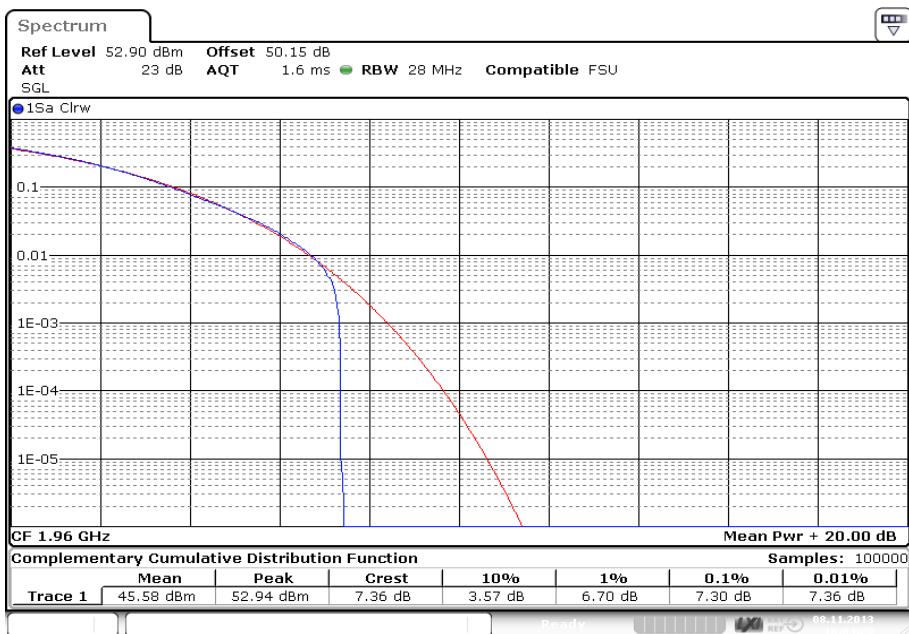

Date: 8.NOV.2013 16:04:20

Channel Position M - Modulation 16-QAM

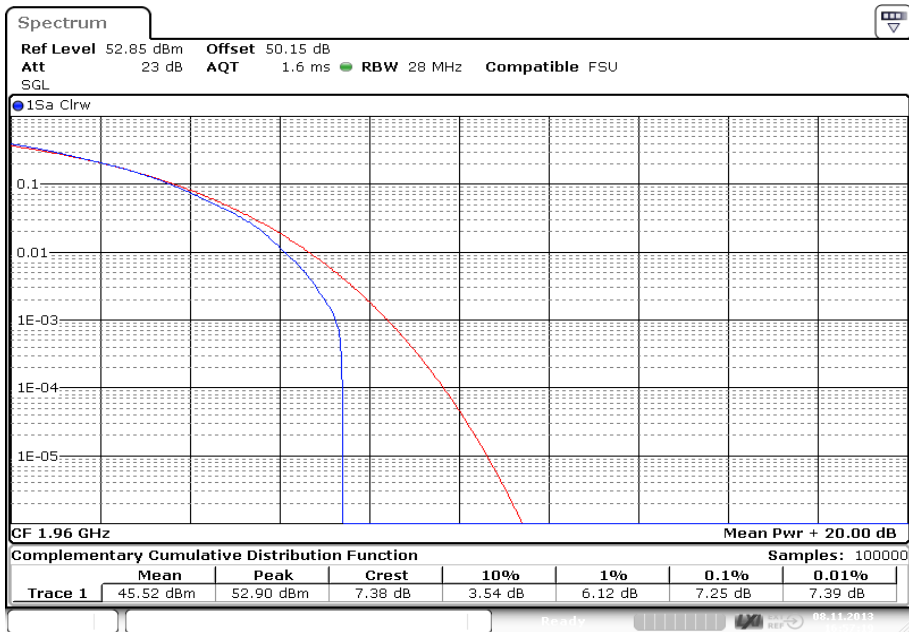

Date: 8.NOV.2013 16:57:20

Channel Position T - Modulation QPSK

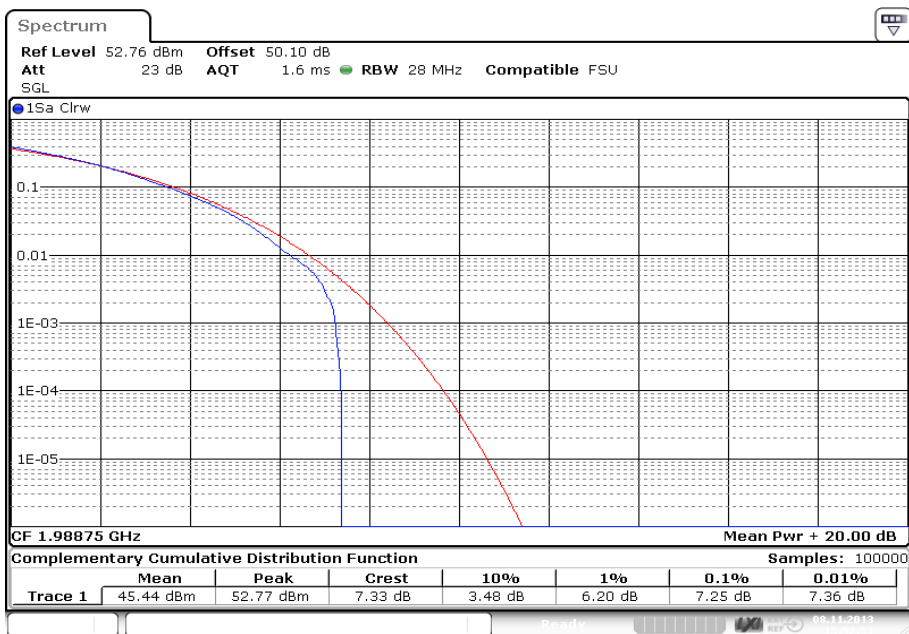

Date: 8.NOV.2013 15:52:51

Channel Position T - Modulation 8-PSK

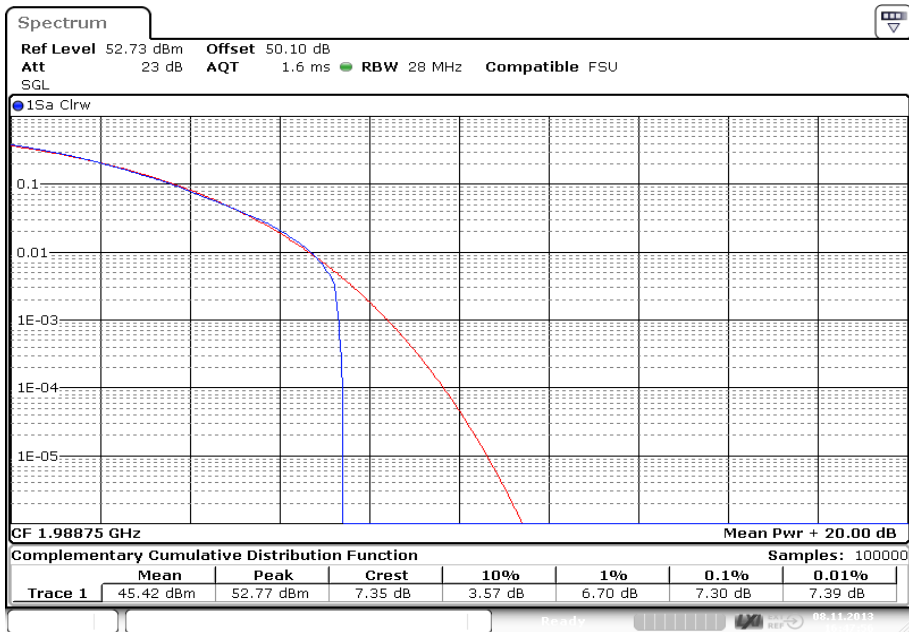

Date: 8.NOV.2013 16:47:57

Channel Position T - Modulation 16-QAM

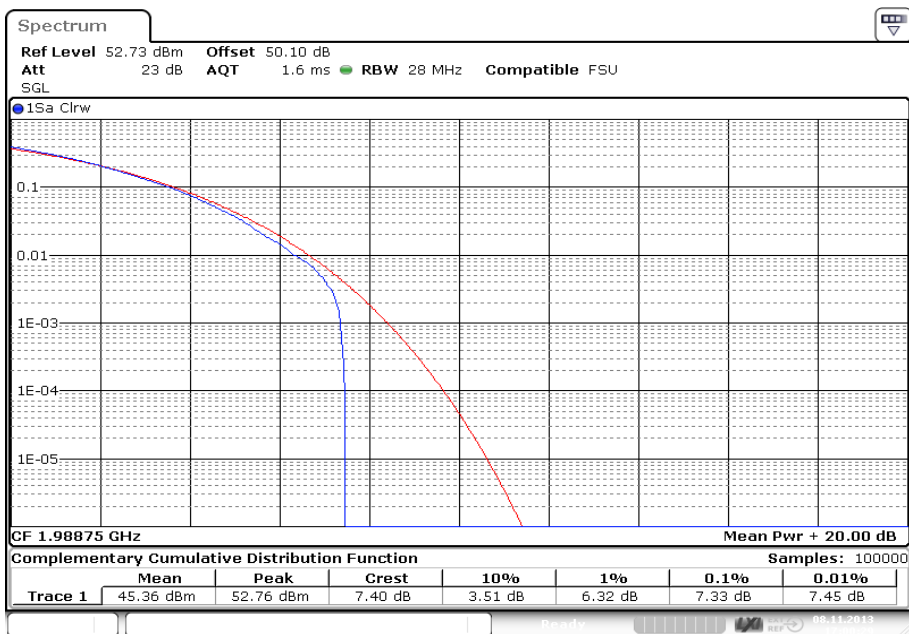

Date: 8.NOV.2013 17:00:30

Configuration CDMA-MC1 (See Table 2 for carrier frequency)

Maximum Output Power 43 dBm per carrier, QPSK Modulation

Modulation	Average Output Power (dBm)		
	Channel Position B	Channel Position M	Channel Position T
QPSK	-	45.82	-
8-PSK	-	45.50	-
16-QAM	-	45.64	-

Configuration CDMA-MC2

Maximum Output Power 40 dBm per carrier, QPSK Modulation

Modulation	Average Output Power (dBm)		
	Channel Position B	Channel Position M	Channel Position T
QPSK	-	45.56	-
8-PSK	-	45.33	-
16-QAM	-	45.47	-

Configuration LTE+CDMA-MC1 (See Table 1 for carrier frequency)

Maximum Output Power 43 dBm per carrier, Test Model 1.1 / QPSK Modulation
Single Port

CDMA Modulation / LTE Bandwidth	Average Output Power (dBm)		
	Channel Position BRFBW	Channel Position MRFBW	Channel Position TRFBW
QPSK / 5.0 MHz	-	45.59	-

Configuration LTE+CDMA-MC2

Maximum Output Power 40 dBm per carrier, Test Model 1.1 / QPSK Modulation

CDMA Modulation / LTE Bandwidth	Average Output Power (dBm)		
	Channel Position BRFBW	Channel Position MRFBW	Channel Position TRFBW
QPSK / 5.0 MHz	-	45.59	-

Limit	
Peak Power	≤1640 W or ≤+62 dBm (FCC) ≤100 W or ≤+50 dBm (Industry Canada)
Peak to Average Ratio	13 dB

2.2 OCCUPIED BANDWIDTH

2.2.1 Specification Reference

FCC CFR 47 Part 2, Clause 2.1049
FCC CFR 47 Part 24, Clause 24.238(b)
Industry Canada RSS-GEN. Clause 4.6

2.2.2 Date of Test and Modification State

05 November 2013 - Modification State 0

2.2.3 Test Equipment Used

The major items of test equipment used for the above tests are identified in Section 3.1.

2.2.4 Environmental Conditions

Ambient Temperature	22.8°C
Relative Humidity	32.7%

2.2.5 Test Method

The Spectrum Analyser RBW was configured to be at least 1% of the channel bandwidth of the carrier to be measured.

For 99% Occupied Bandwidth, the Spectrum Analysers measurement mode was used in conjunction with an RMS detector and a long sweep time as described in the operating manual for the test equipment.

For 26dB Bandwidth, in accordance with KDB 971168 D01, a peak detector and a trace setting of Max Hold were used. Once the trace had stabilised, the peak of the signal was found. From this point, the 26dBc points were established. The difference between the two marker points was calculated and recorded.

The results are shown in the plots below.

2.2.6 Test Results

Configuration LTE-SC (See Table 1 for carrier frequency)

Maximum Output Power 46 dBm per carrier, Test Model 1.1

Measurement	Carrier Bandwidth	Occupied Bandwidth (MHz)		
		Channel Position B	Channel Position M	Channel Position T
99 % Bandwidth	5.0 MHz	4.469	4.469	4.469
	10.0 MHz	8.944	8.944	8.944
	15.0 MHz	13.386	13.386	13.386
	20.0 MHz	17.844	17.887	17.887
26 dB Bandwidth	5.0 MHz	4.838	4.838	4.838
	10.0 MHz	9.696	9.648	9.672
	15.0 MHz	14.560	14.560	14.600
	20.0 MHz	19.248	19.248	19.296

Measurement 99 % Occupied Bandwidth - Channel Position B - Carrier Bandwidth 5.0 MHz

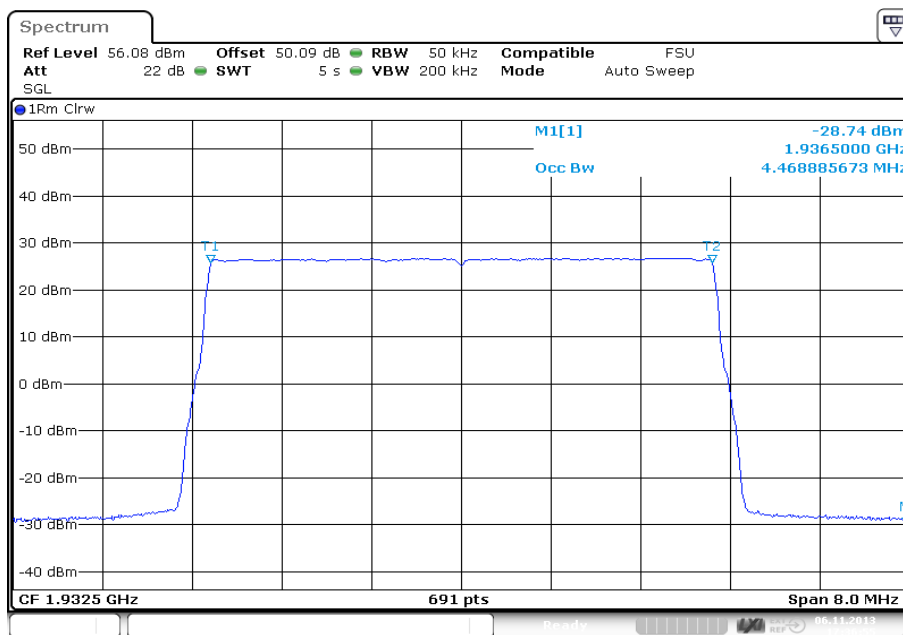

Date: 6.NOV.2013 17:36:55

Measurement 99 % Occupied Bandwidth - Channel Position B - Carrier Bandwidth 10.0 MHz

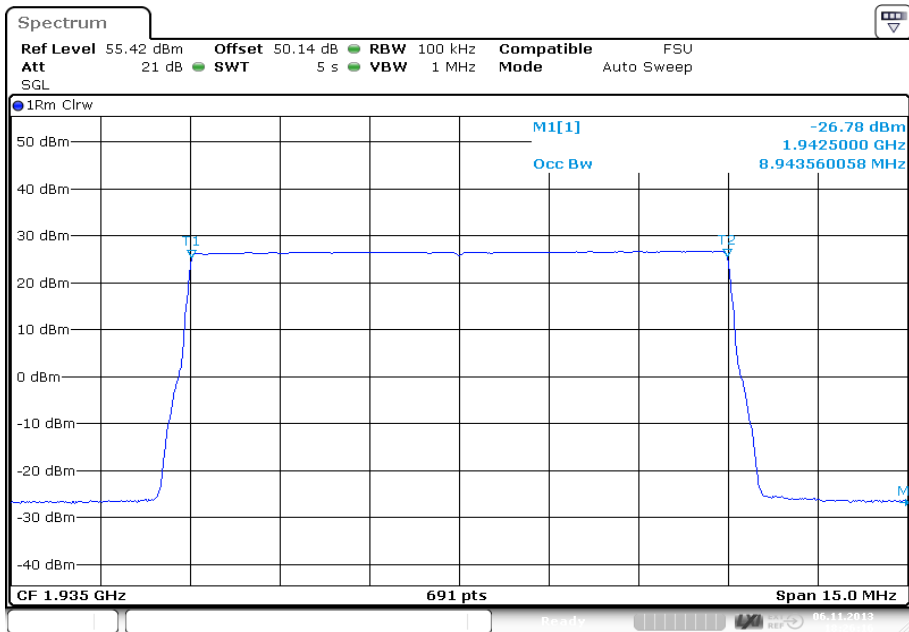

Date: 6.NOV.2013 18:26:17

Measurement 99 % Occupied Bandwidth - Channel Position B - Carrier Bandwidth 15.0 MHz

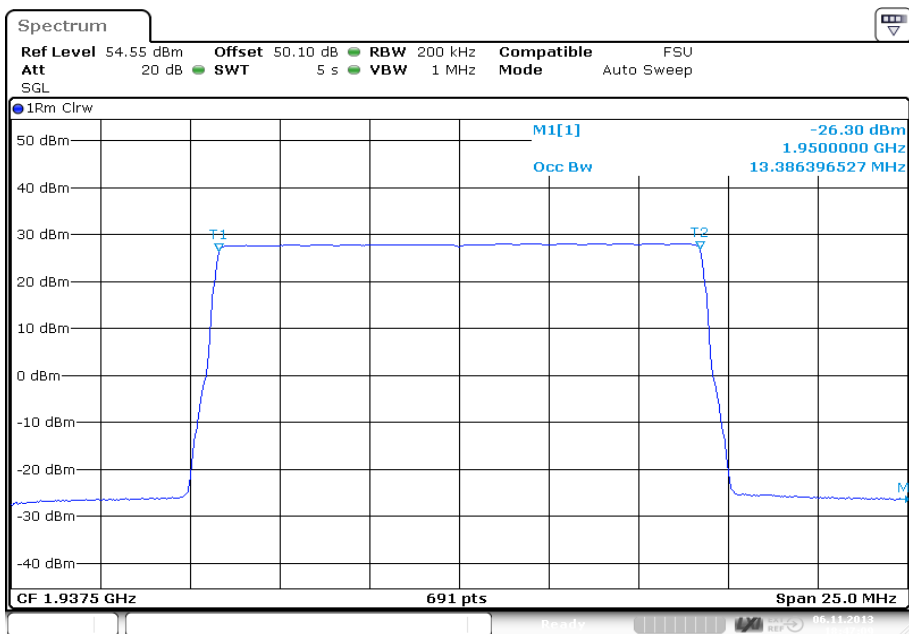

Date: 6.NOV.2013 18:47:09

Measurement 99 % Occupied Bandwidth - Channel Position B - Carrier Bandwidth 20.0 MHz

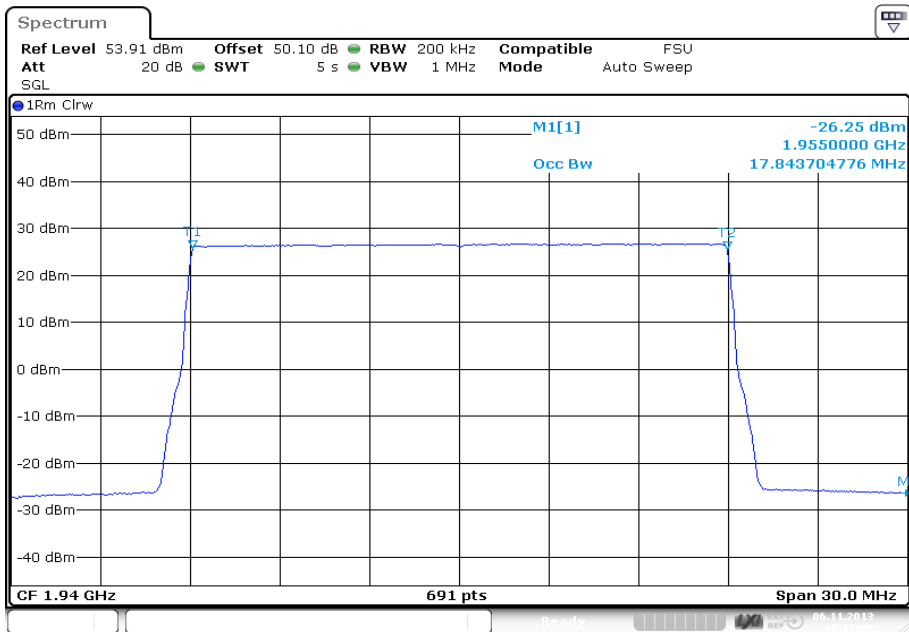

Measurement 99 % Occupied Bandwidth - Channel Position M - Carrier Bandwidth 5.0 MHz

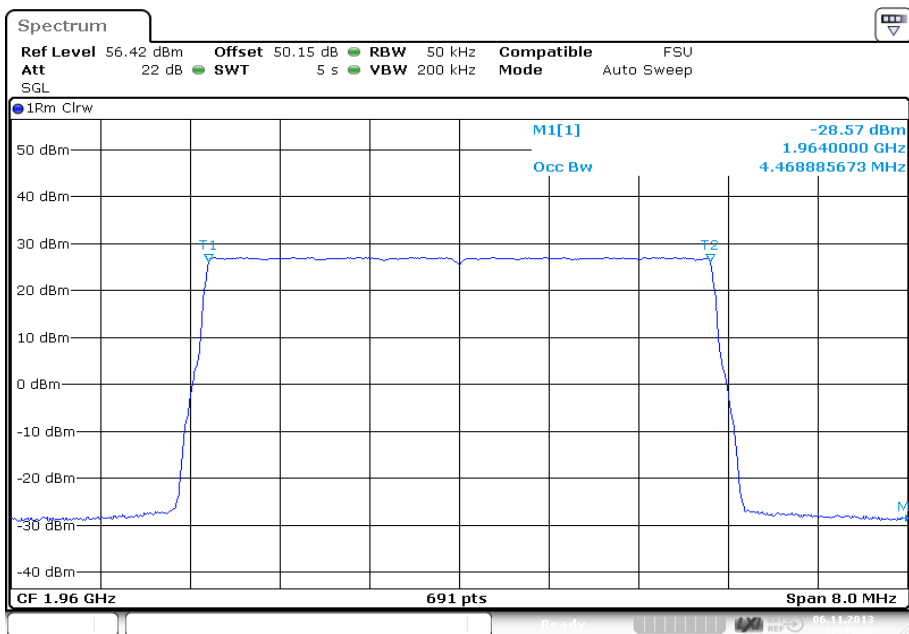

Measurement 99 % Occupied Bandwidth - Channel Position M - Carrier Bandwidth 10.0 MHz

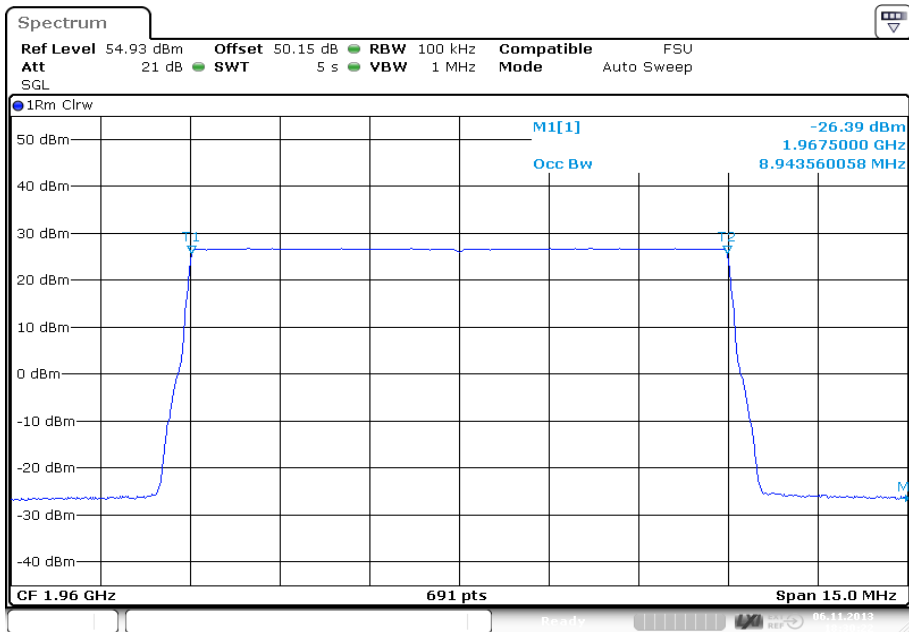

Measurement 99 % Occupied Bandwidth - Channel Position M - Carrier Bandwidth 15.0 MHz

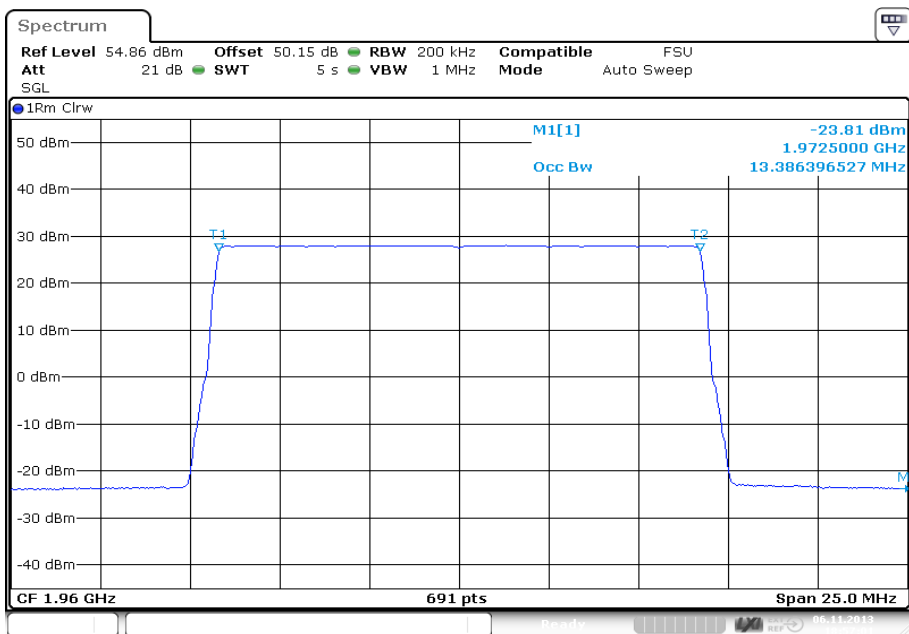

Measurement 99 % Occupied Bandwidth - Channel Position M - Carrier Bandwidth 20.0 MHz

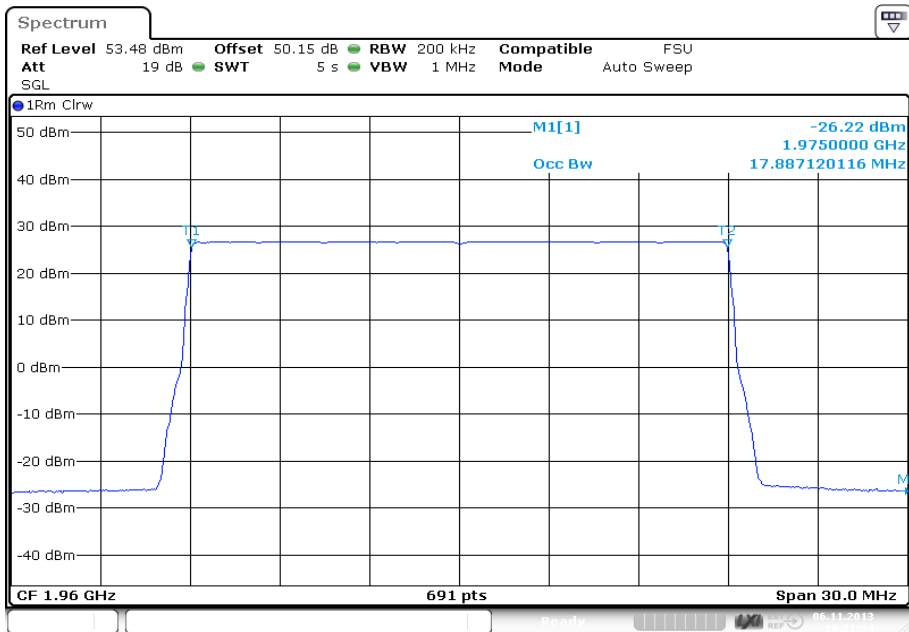

Measurement 99 % Occupied Bandwidth - Channel Position T - Carrier Bandwidth 5.0 MHz

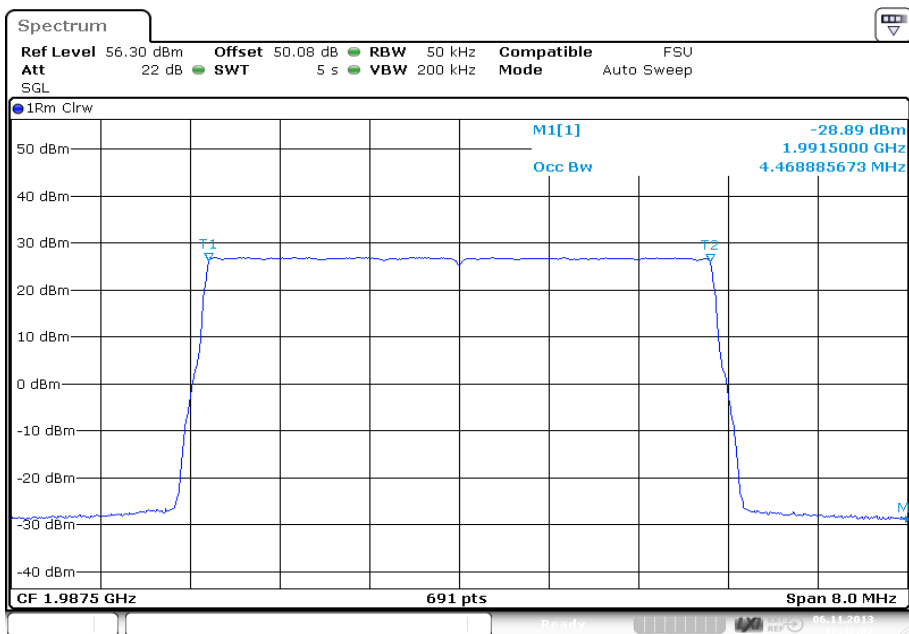

Measurement 99 % Occupied Bandwidth - Channel Position T - Carrier Bandwidth 10.0 MHz

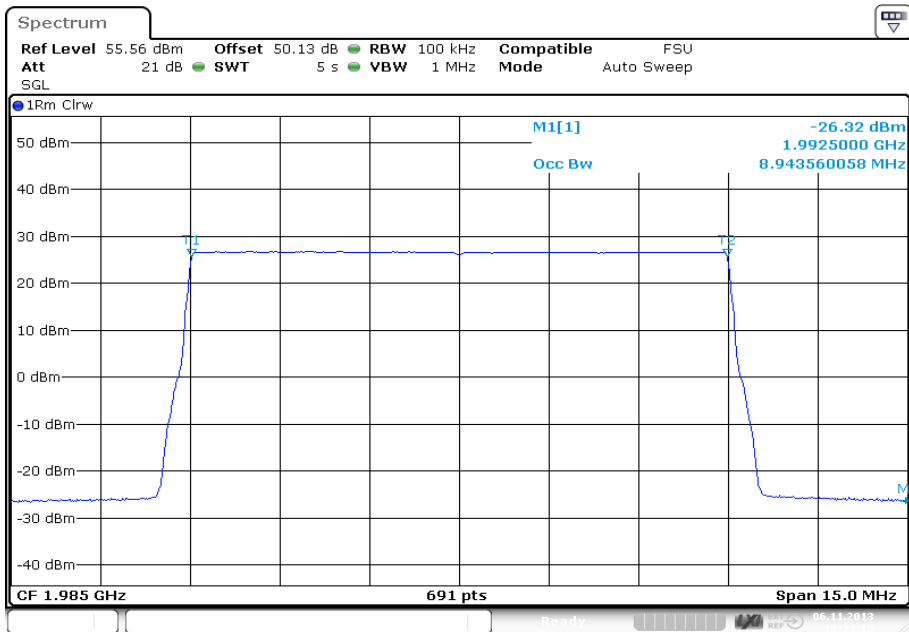

Date: 6.NOV.2013 18:33:15

Measurement 99 % Occupied Bandwidth - Channel Position T - Carrier Bandwidth 15.0 MHz

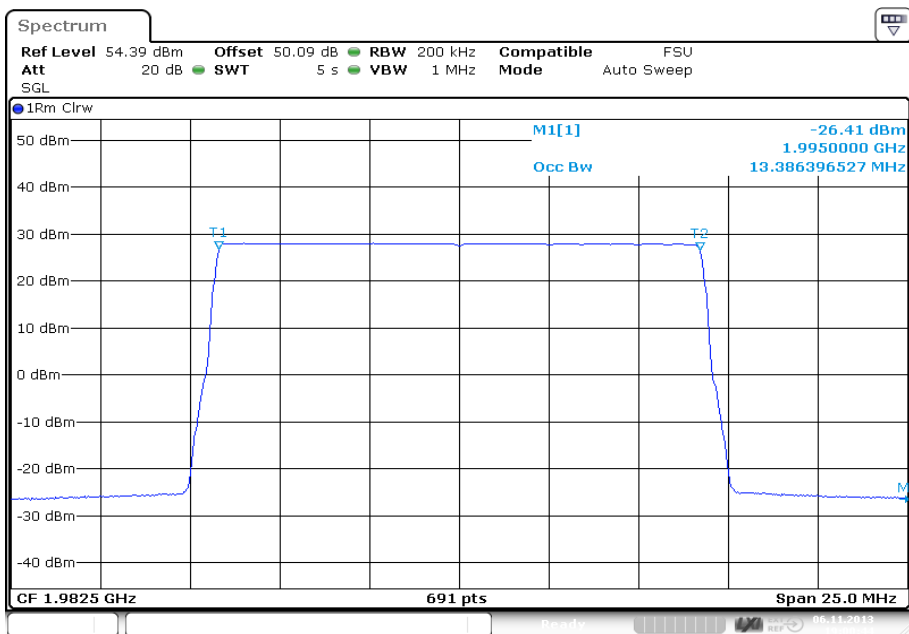

Date: 6.NOV.2013 19:00:45

Measurement 99 % Occupied Bandwidth - Channel Position T - Carrier Bandwidth 20.0 MHz

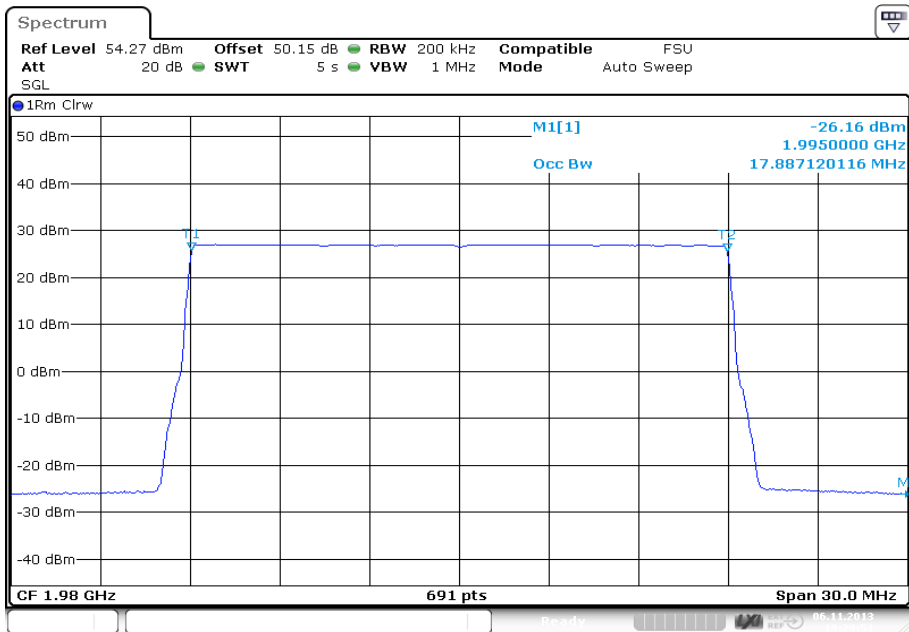

Measurement 26 dB Bandwidth - Channel Position B - Carrier Bandwidth 5.0 MHz

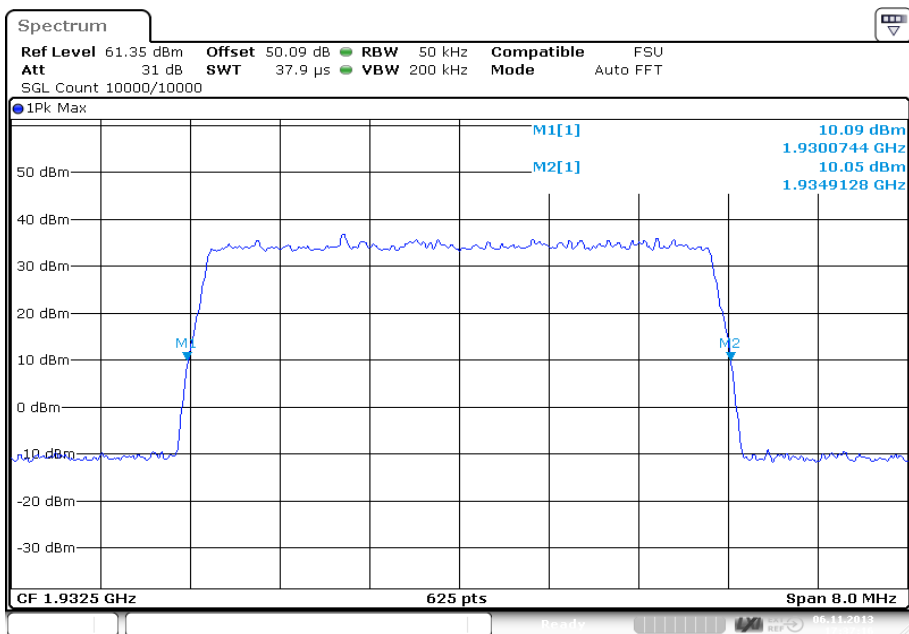

Measurement 26 dB Bandwidth - Channel Position B - Carrier Bandwidth 10.0 MHz

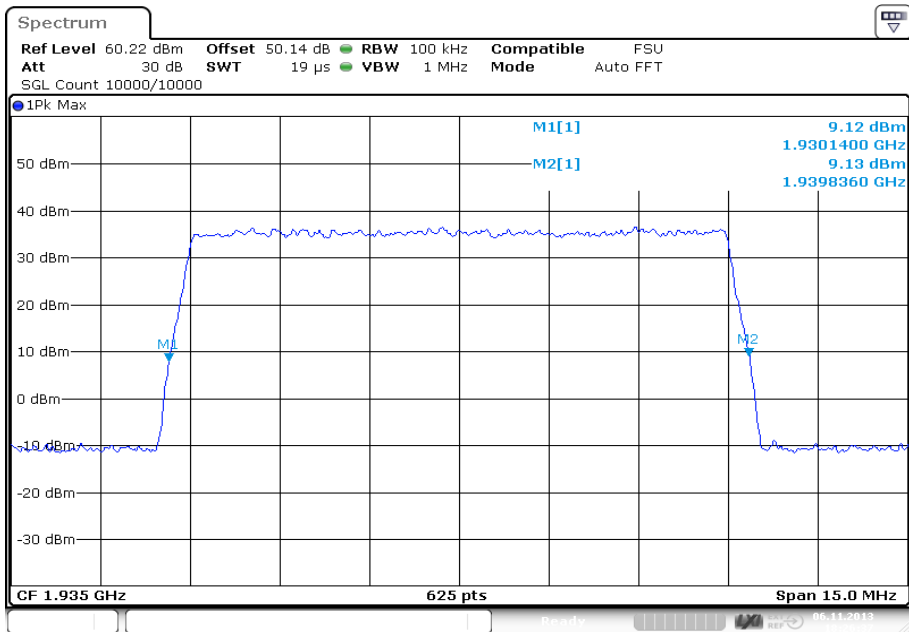

Measurement 26 dB Bandwidth - Channel Position B - Carrier Bandwidth 15.0 MHz

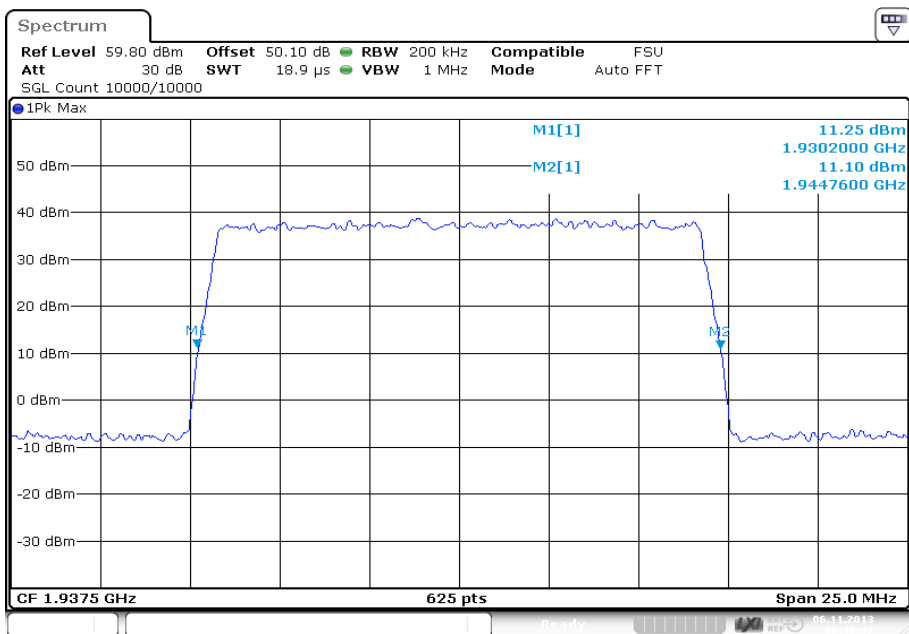

Measurement 26 dB Bandwidth - Channel Position B - Carrier Bandwidth 20.0 MHz

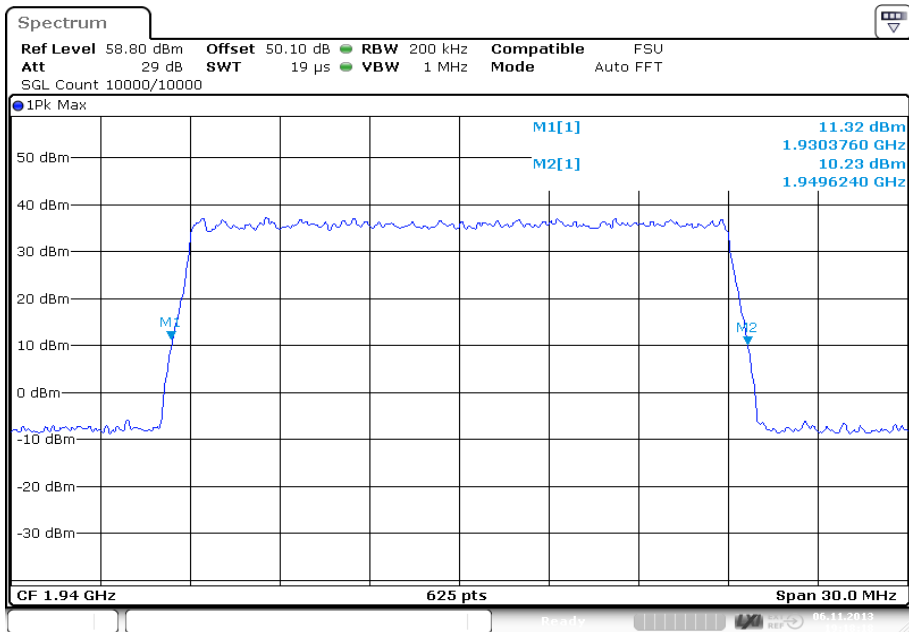

Measurement 26 dB Bandwidth - Channel Position M - Carrier Bandwidth 5.0 MHz

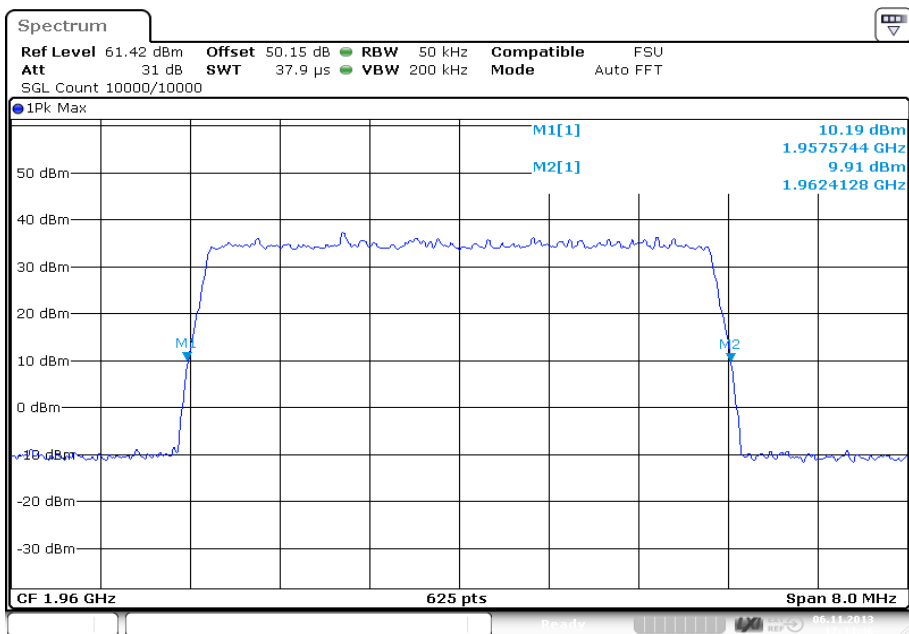

Measurement 26 dB Bandwidth - Channel Position M - Carrier Bandwidth 10.0 MHz

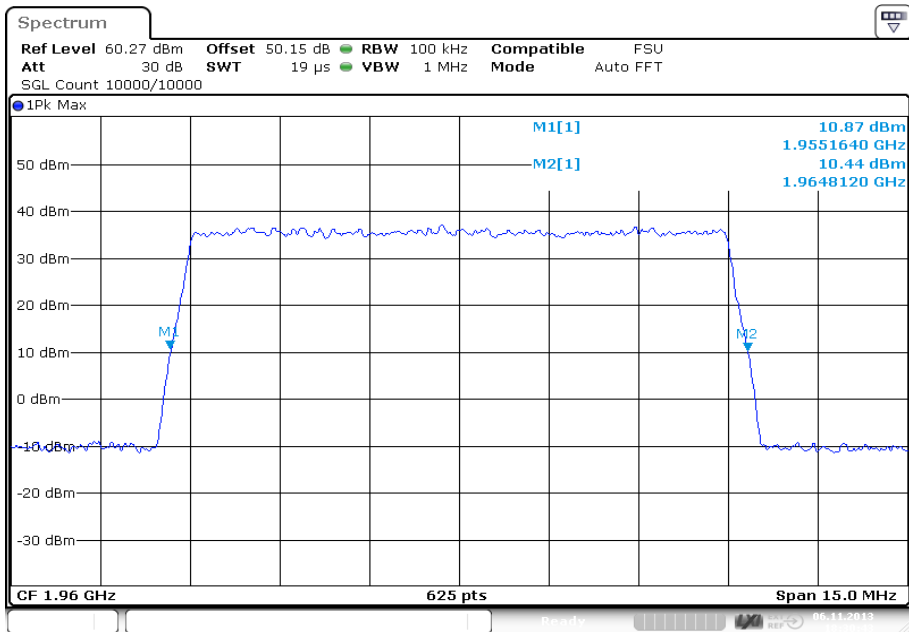

Measurement 26 dB Bandwidth - Channel Position M - Carrier Bandwidth 15.0 MHz

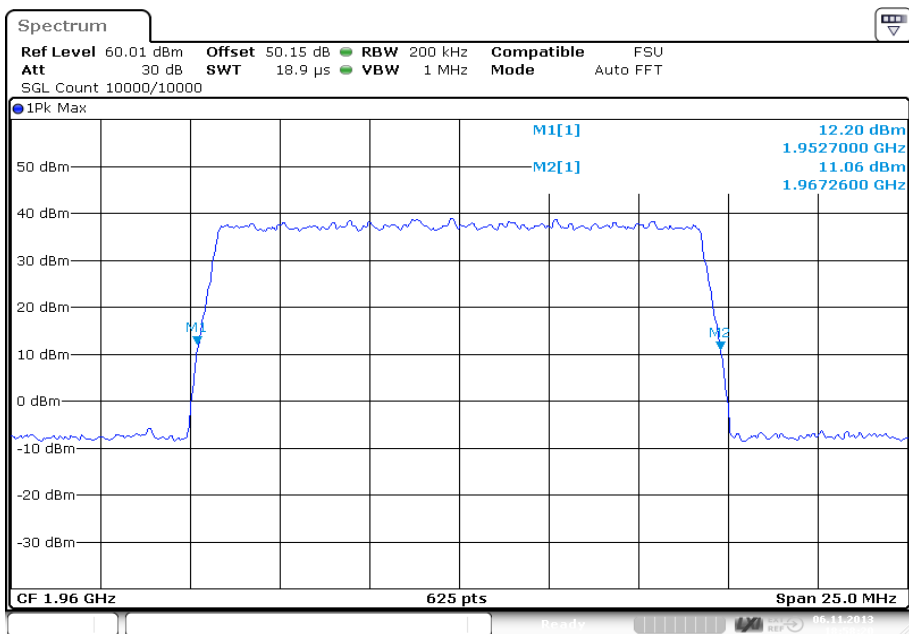

Measurement 26 dB Bandwidth - Channel Position M - Carrier Bandwidth 20.0 MHz

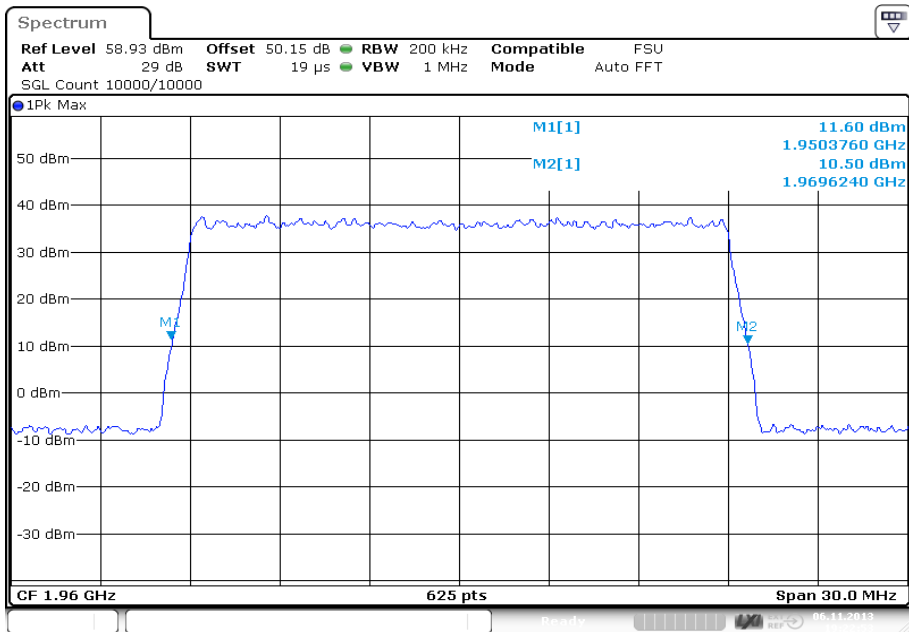

Measurement 26 dB Bandwidth - Channel Position T - Carrier Bandwidth 5.0 MHz

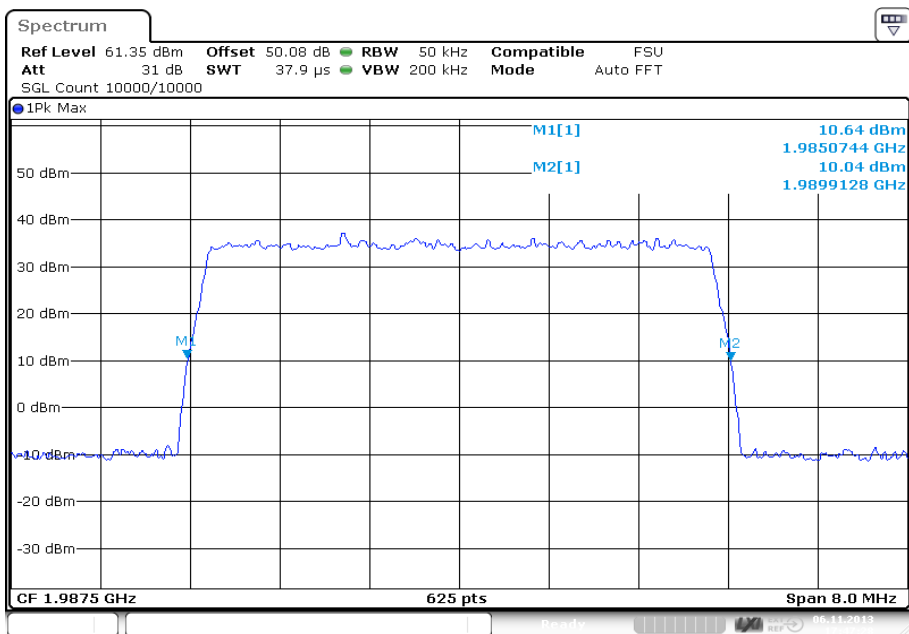

Measurement 26 dB Bandwidth - Channel Position T - Carrier Bandwidth 10.0 MHz

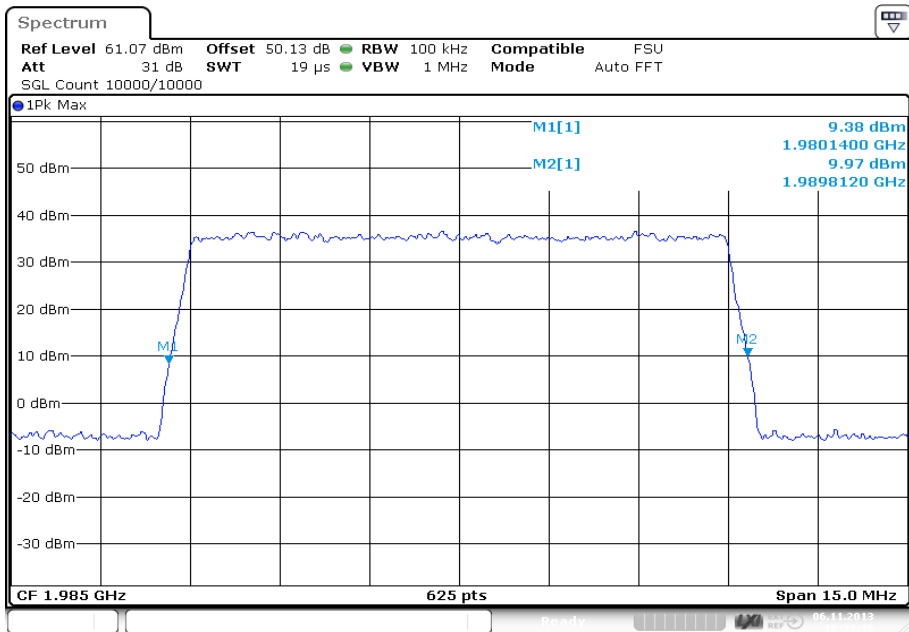

Measurement 26 dB Bandwidth - Channel Position T - Carrier Bandwidth 15.0 MHz

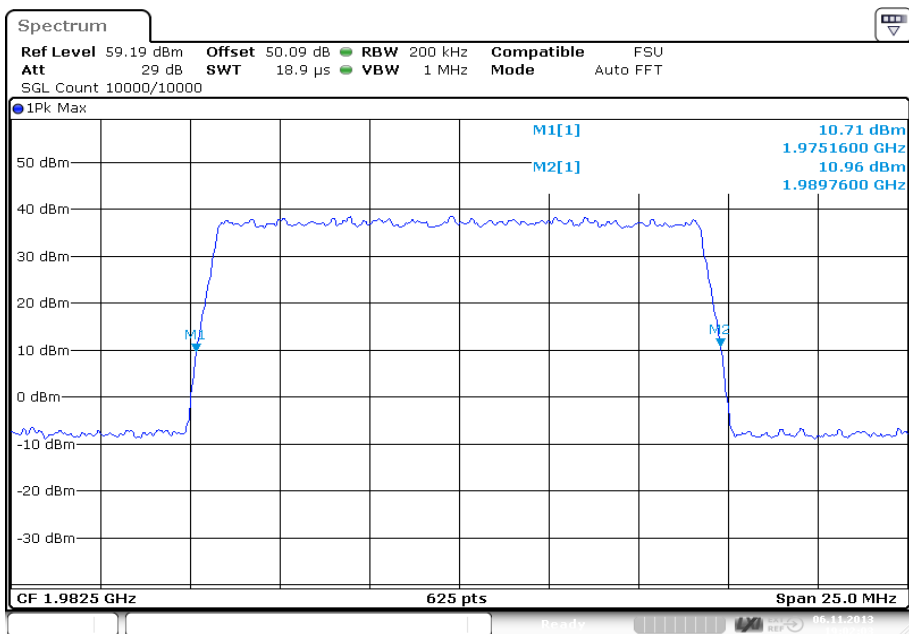

Measurement 26 dB Bandwidth - Channel Position T - Carrier Bandwidth 20.0 MHz

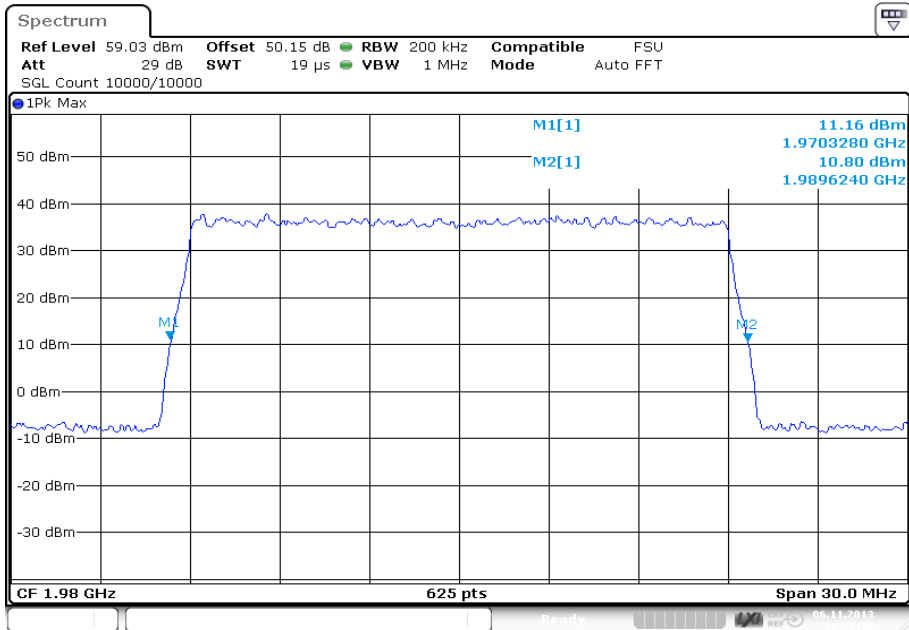

Date: 6.NOV.2013 19:31:11

Configuration CDMA-SC (See Table 1 for carrier frequency)

Maximum Output Power 46 dBm per carrier

Measurement	Modulation	Occupied Bandwidth (MHz)		
		Channel Position B	Channel Position M	Channel Position T
99 % Bandwidth	QPSK	1.250362	1.250362	1.250362
	8-PSK	1.250362	1.250362	1.250362
	16-QAM	1.250362	1.250362	1.250362
26 dB Bandwidth	QPSK	1.382400	1.372800	1.376000
	8-PSK	1.372800	1.372800	1.376000
	16-QAM	1.379200	1.379200	1.376000

Measurement 99 % Bandwidth - Channel Position B - Modulation QPSK

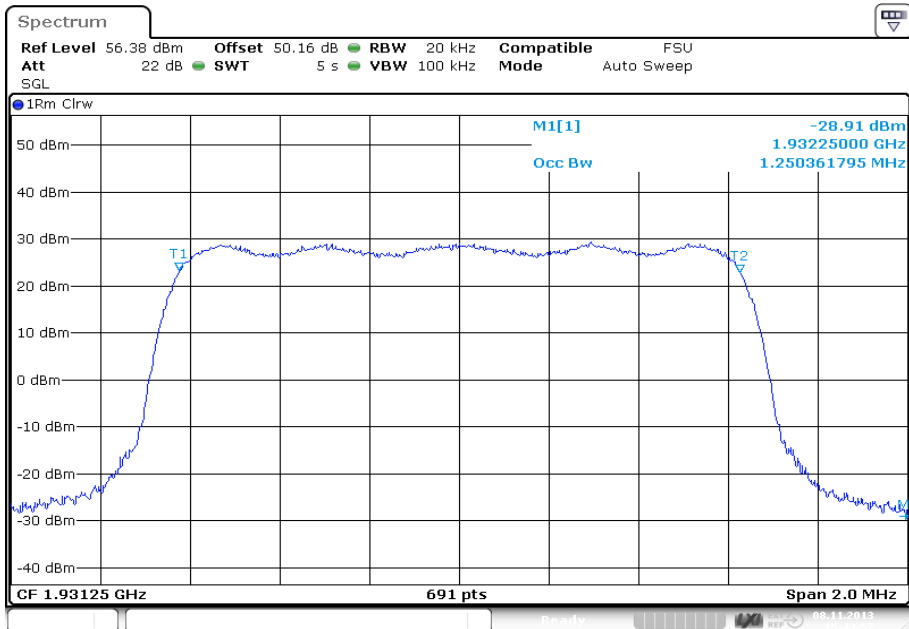

Date: 8.NOV.2013 15:44:57

Measurement 99 % Bandwidth - Channel Position B - Modulation 8-PSK

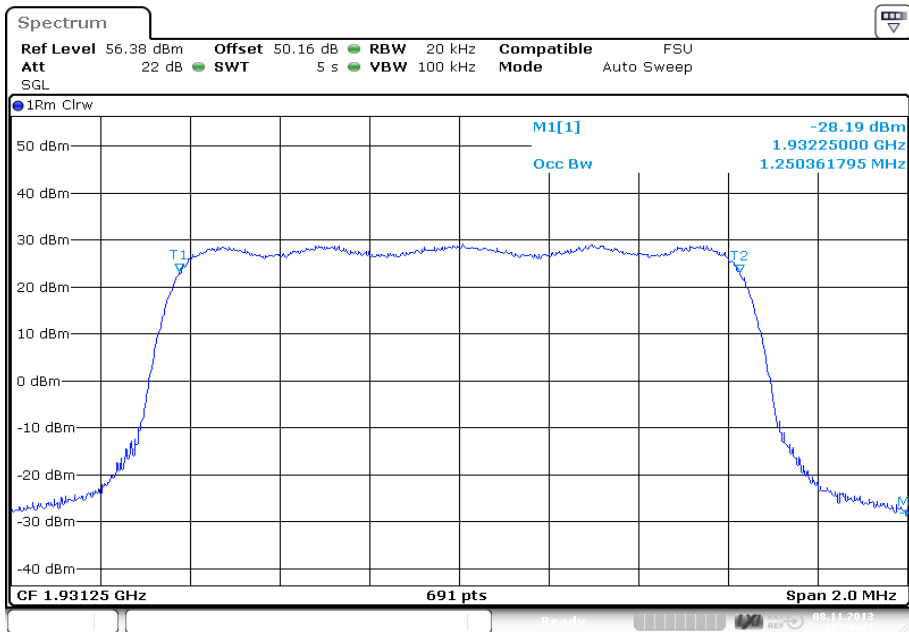

Measurement 99 % Bandwidth - Channel Position B - Modulation 16-QAM

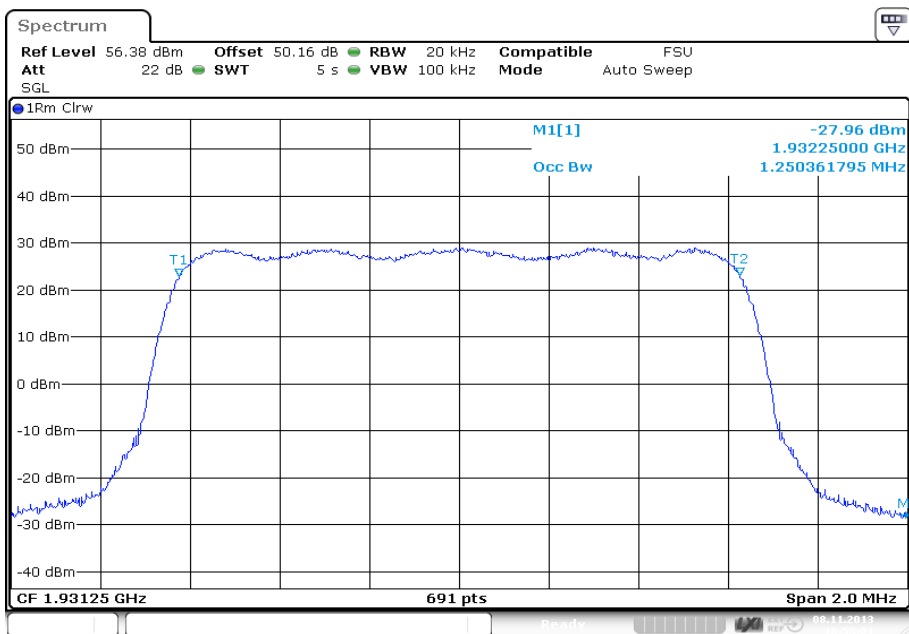

Measurement 99 % Bandwidth - Channel Position M - Modulation QPSK

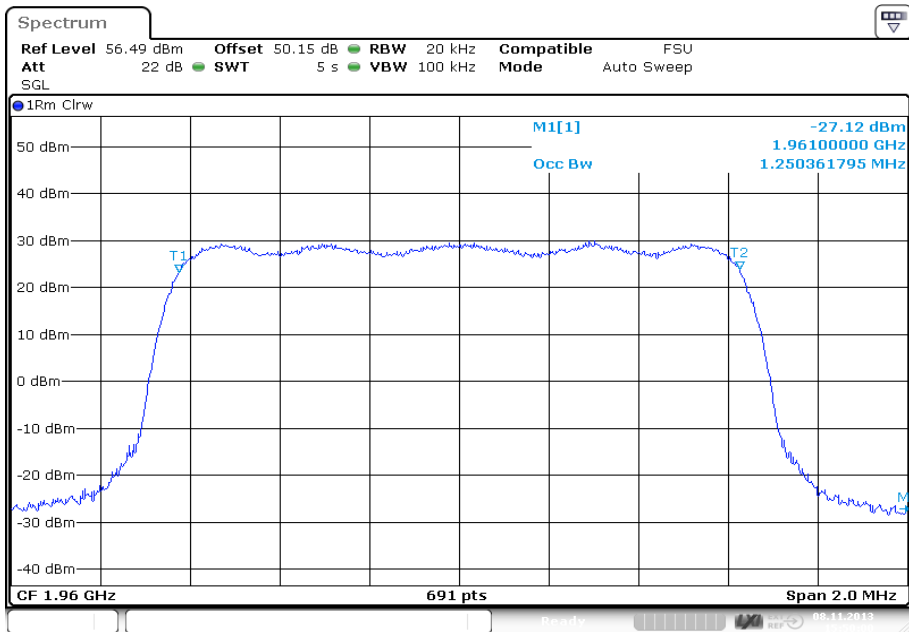

Date: 8.NOV.2013 15:50:00

Measurement 99 % Bandwidth - Channel Position M - Modulation 8-PSK

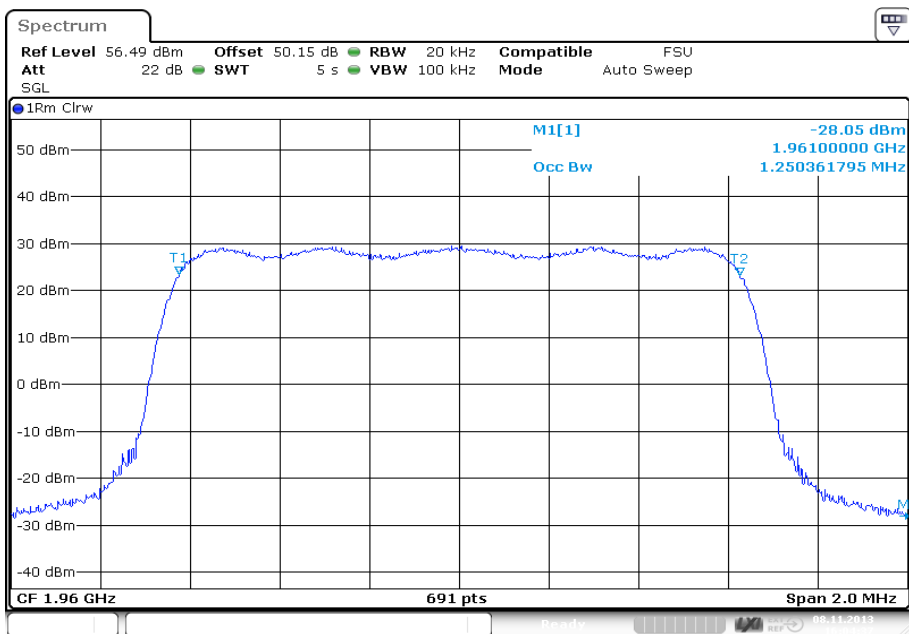

Date: 8.NOV.2013 16:04:37

Measurement 99 % Bandwidth - Channel Position M - Modulation 16-QAM

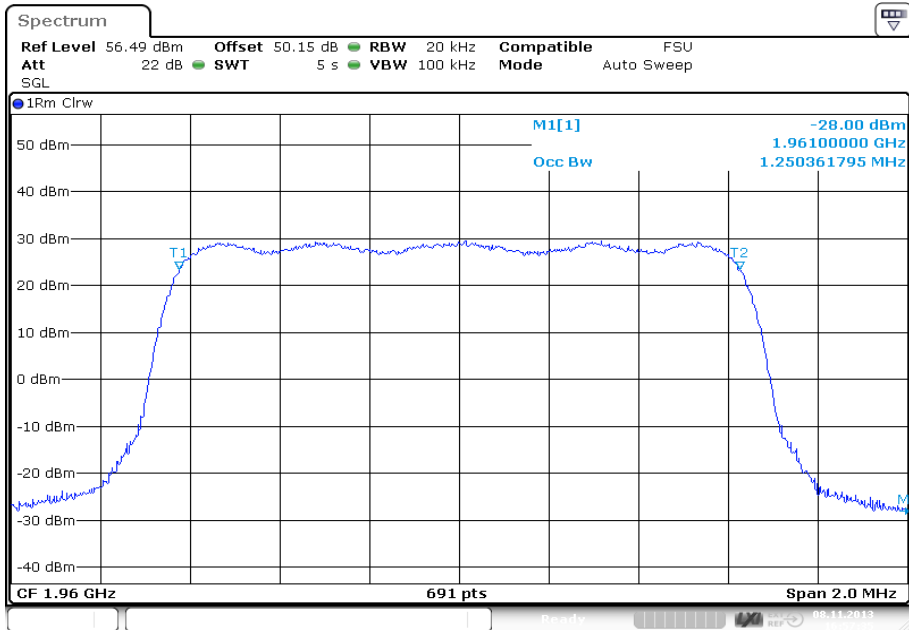

Date: 8.NOV.2013 16:57:35

Measurement 99 % Bandwidth - Channel Position T - Modulation QPSK

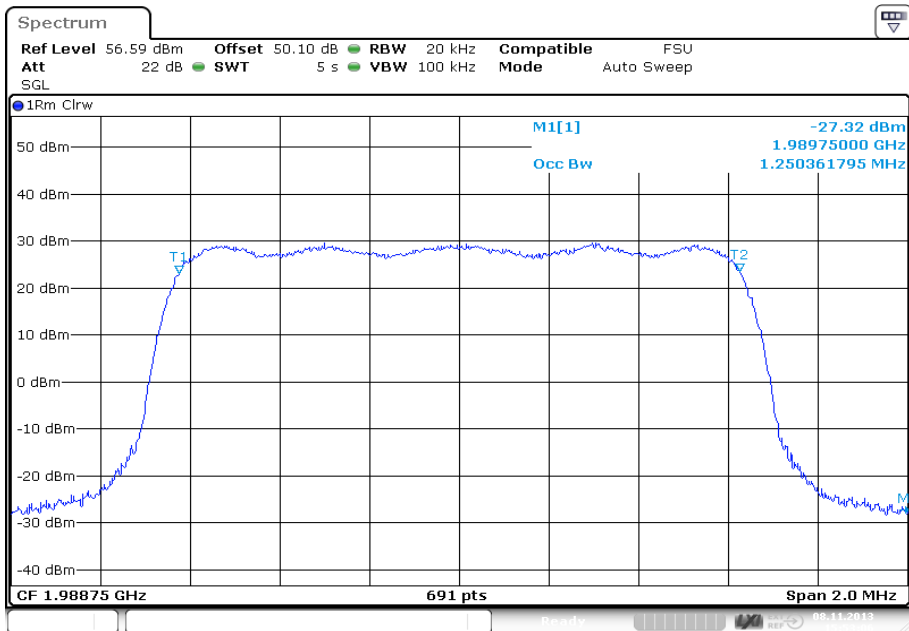

Date: 8.NOV.2013 15:53:06

Measurement 99 % Bandwidth - Channel Position T - Modulation 8-PSK

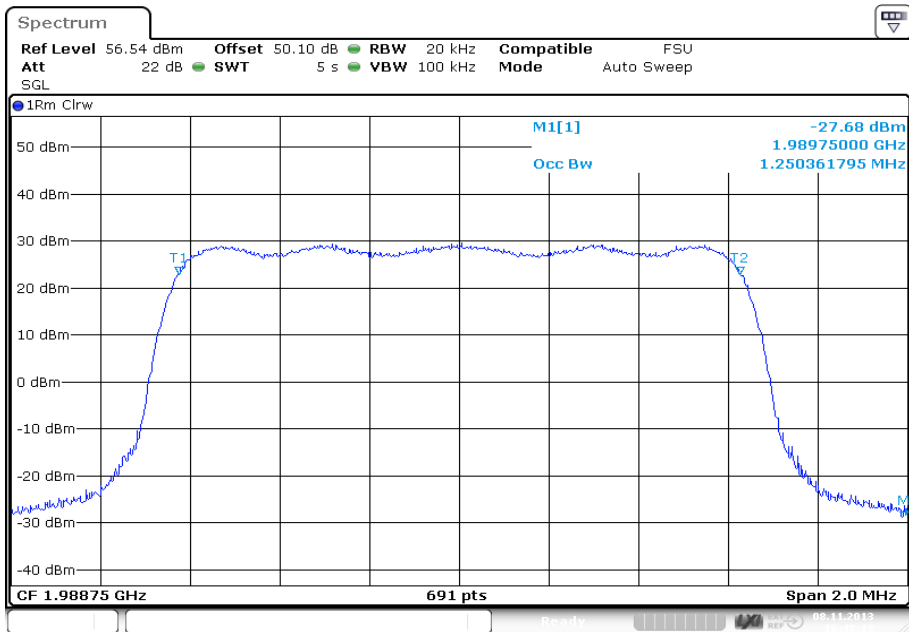

Measurement 99 % Bandwidth - Channel Position T - Modulation 16-QAM

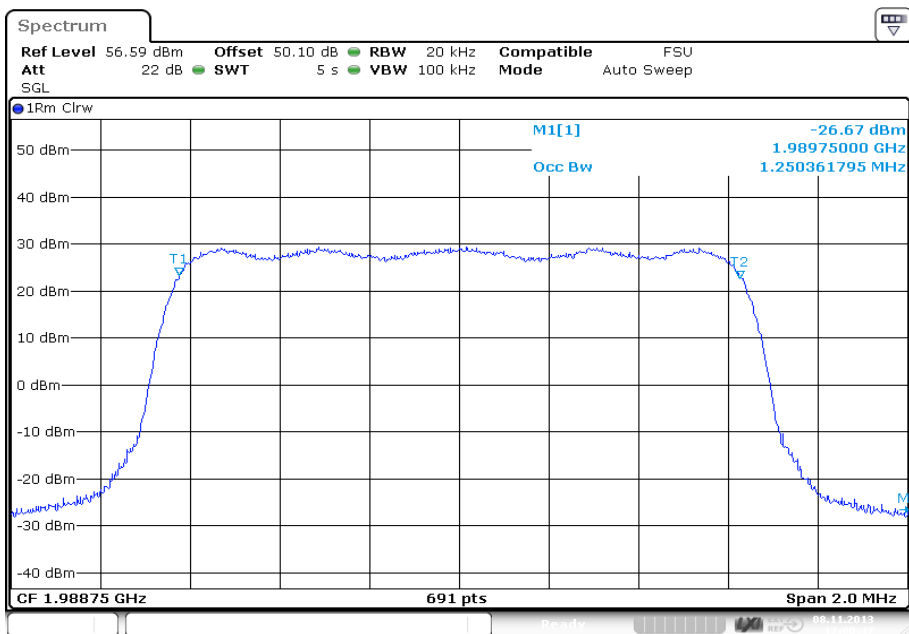

Measurement 26 dB Bandwidth - Channel Position B - Modulation QPSK

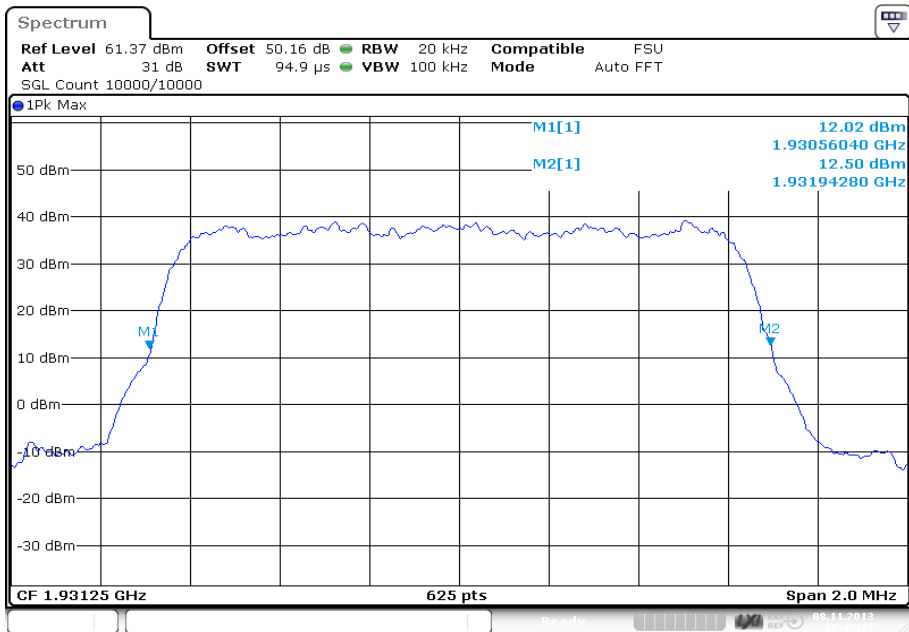

Measurement 26 dB Bandwidth - Channel Position B - Modulation 8-PSK

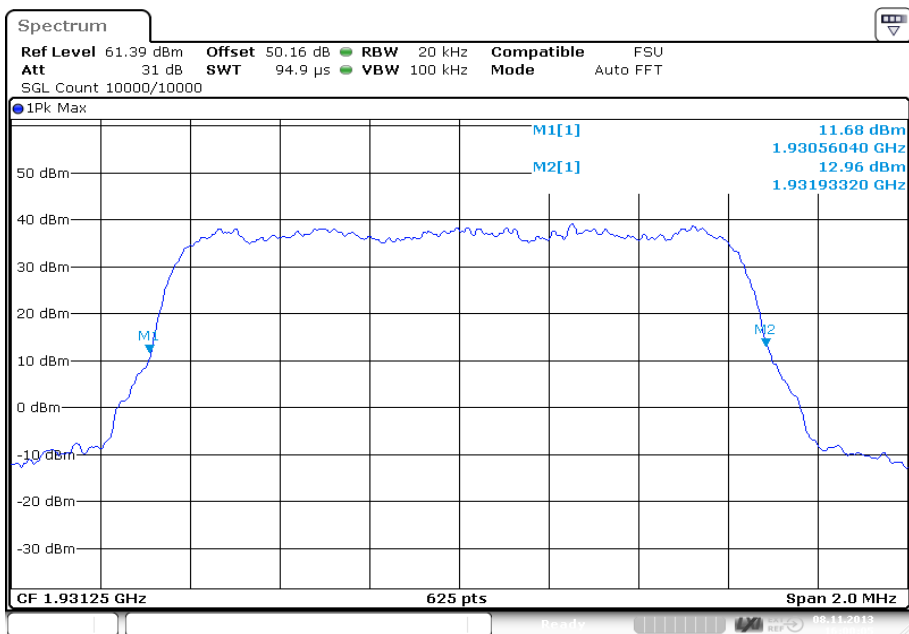

Measurement 26 dB Bandwidth - Channel Position B - Modulation 16-QAM

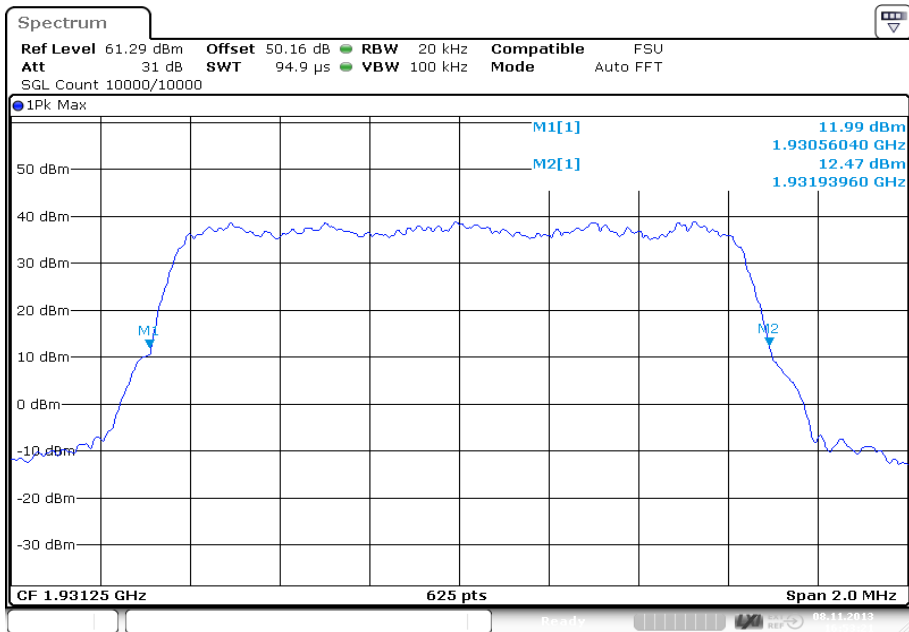

Measurement 26 dB Bandwidth - Channel Position M - Modulation QPSK

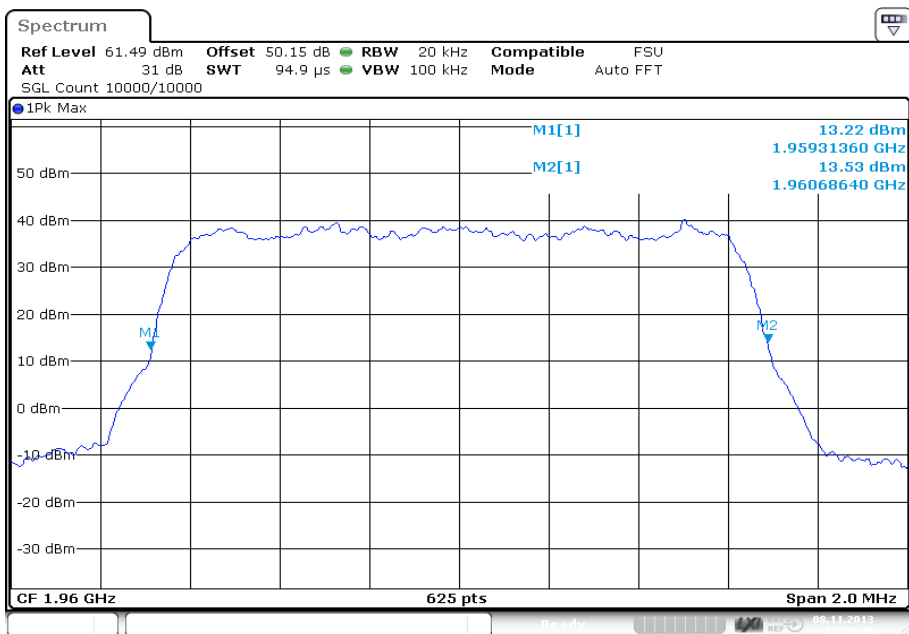

Measurement 26 dB Bandwidth - Channel Position M - Modulation 8-PSK

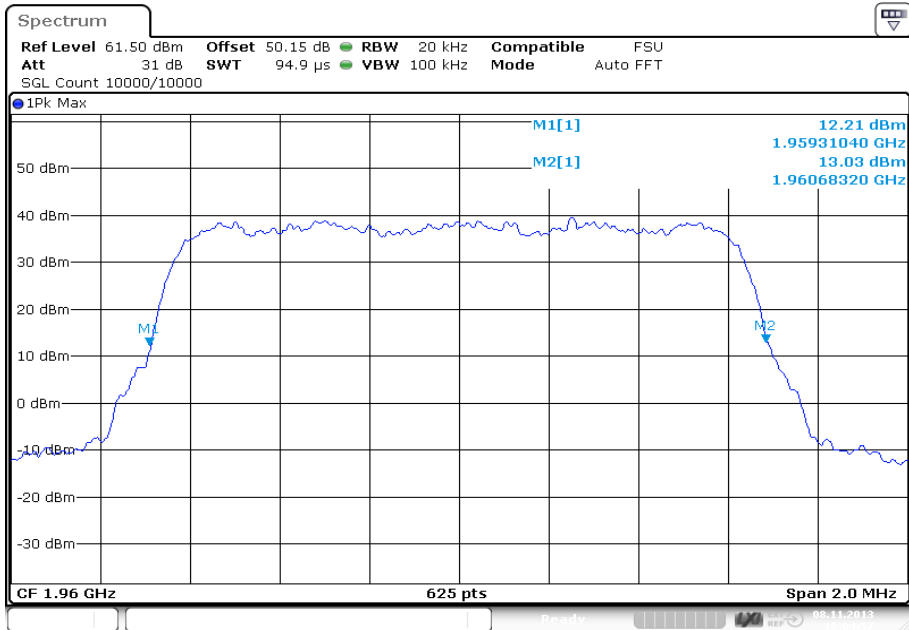

Measurement 26 dB Bandwidth - Channel Position M - Modulation 16-QAM

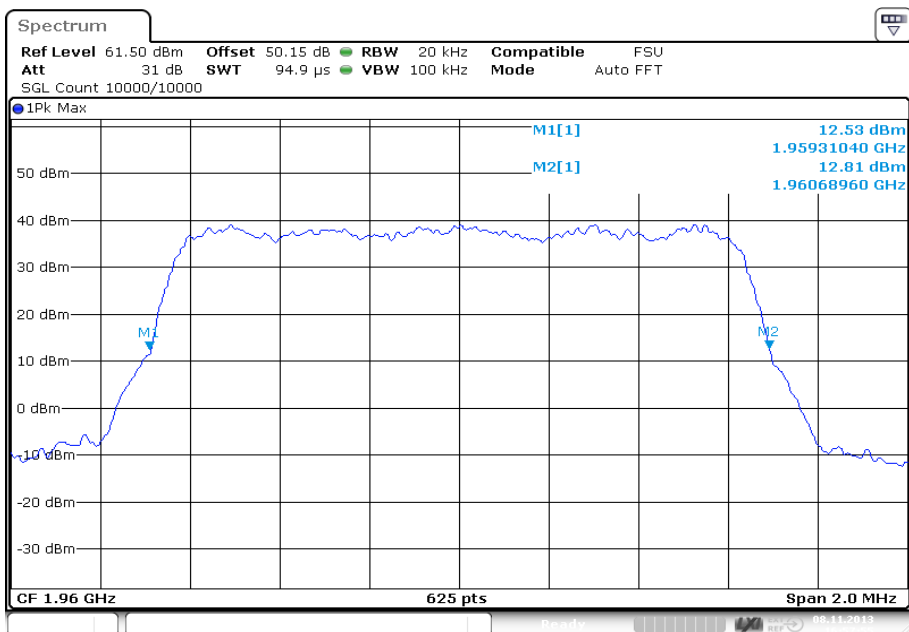

Measurement 26 dB Bandwidth - Channel Position T - Modulation QPSK

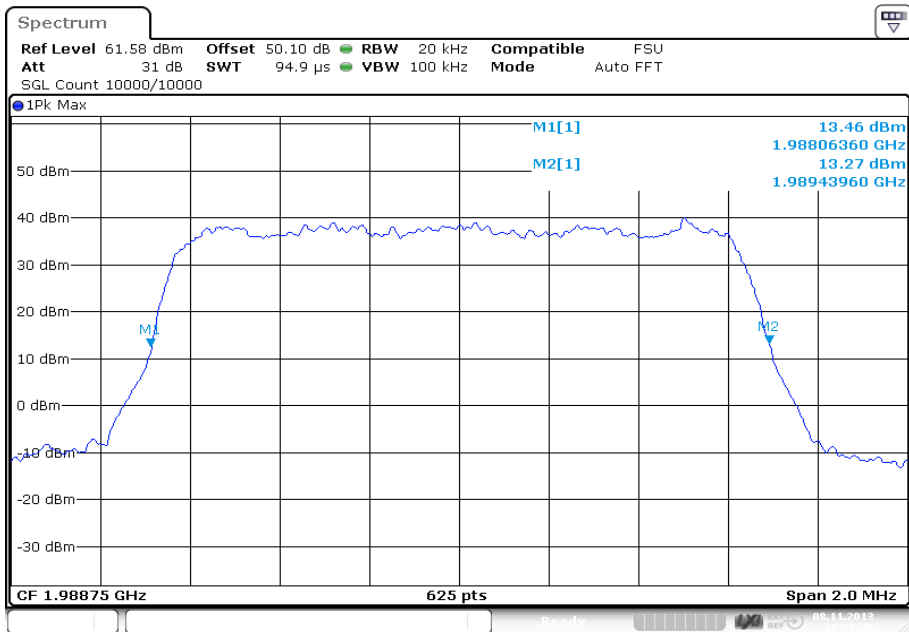

Measurement 26 dB Bandwidth - Channel Position T - Modulation 8-PSK

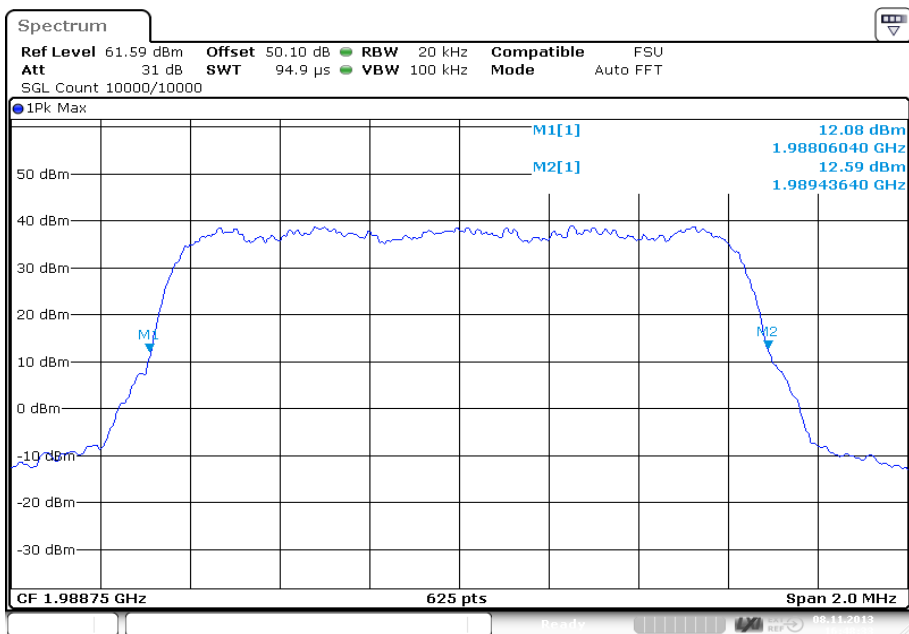

Measurement 26 dB Bandwidth - Channel Position T - Modulation 16-QAM

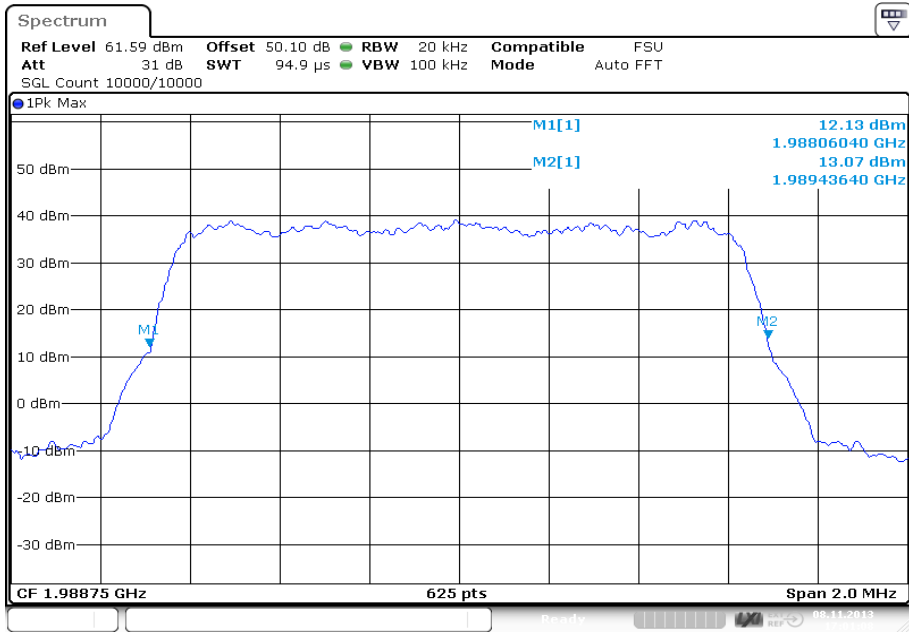

Date: 8.NOV.2013 17:01:08

2.3 SPURIOUS EMISSIONS AT BAND EDGE

2.3.1 Specification Reference

FCC CFR 47 Part 2, Clause 2.1051
FCC CFR 47 Part 24, Clause 24.238(b)
Industry Canada RSS-133, Clause 6.5

2.3.2 Date of Test and Modification State

06, 08 and 12 November 2013 - Modification State 0

2.3.3 Test Equipment Used

The major items of test equipment used for the above tests are identified in Section 3.1.

2.3.4 Environmental Conditions

Ambient Temperature	22.8 - 24.2°C
Relative Humidity	33.7 - 39.4%

2.3.5 Test Method

The EUT was connected to a Spectrum Analyser via 50dB of attenuation. The path loss between the EUT and the Spectrum Analyser was measured using a Network Analyser. The measured path loss was entered as a Reference Level Offset in the Spectrum Analyser. The Spectrum Analyser RBW was adjusted to be at least 1% of the measured 26dB Bandwidth. Using an RMS detector, the frequency spectrum up to 1MHz away from the Band Edge was investigated. Where a margin of <10dB was not achieved using a RBW of at least >1% of the 26dB Bandwidth, the Band Power measurement function of the Spectrum Analyser was used. The Band Power span was configured to be at least 1% of the 26dB Bandwidth and was positioned in the 1MHz region which gave the worst case result. The display line was set to the worst case accounting for 4 Port MIMO operation in accordance with KDB 662911 D01. This equated to $43 + 10\log(P) - 10\log(4) = -19\text{dBm}$.

In the case of Multi-Carrier and Multi-RAT measurements, an evaluation was carried out prior to testing to establish the configuration which gave the worst case result based on number of carriers and carrier bandwidth.

The results are shown in the plots below.

2.3.6 Test Results

Configuration LTE-SC (See Table 2 for carrier frequency)

Maximum Output Power 46 dBm per carrier, Test Model 1.1

Carrier Bandwidth	Band Edge (MHz)	
	Channel Position B	Channel Position T
5.0 MHz	1932.50	1987.50
10.0 MHz	1935.00	1985.00
15.0 MHz	1937.50	1982.50
20.0 MHz	1940.00	1980.00

Remarks

The channels shown in the table above are the minimum and maximum channels that can be used in the authorised frequency ranges to maintain compliance. Channels outside of the ranges shown in the above tables shall not be made available to the end user.

Channel Position B - Bandwidth 5.0 MHz

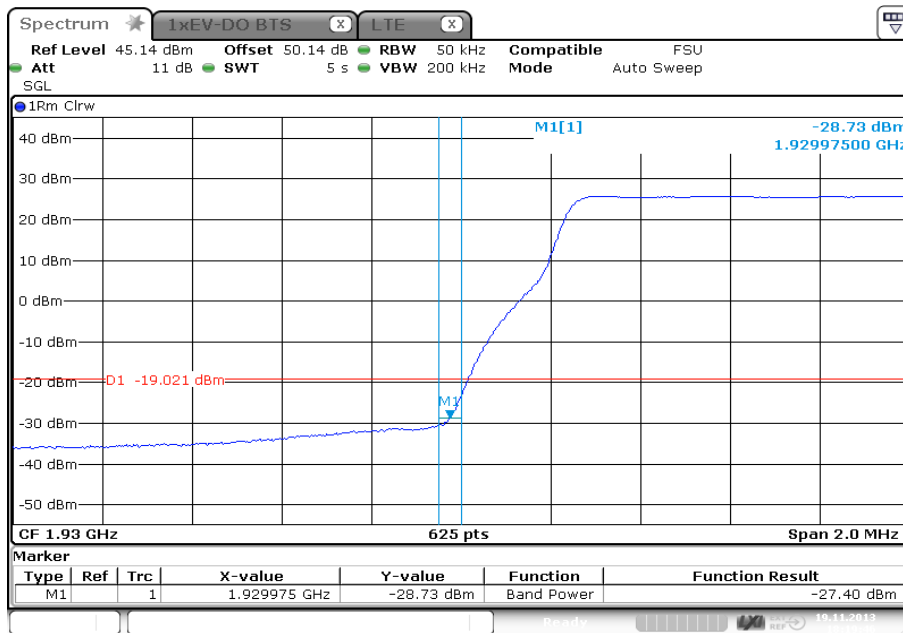

Date: 19.NOV.2013 18:19:46

Channel Position B - Bandwidth 10.0 MHz

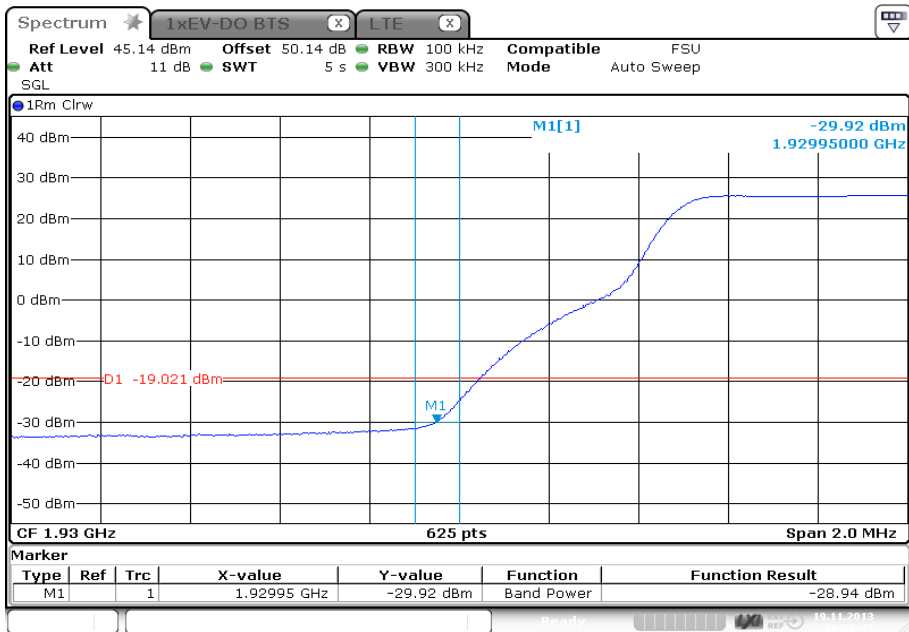

Date: 19.NOV.2013 18:22:45

Channel Position B - Bandwidth 15.0 MHz

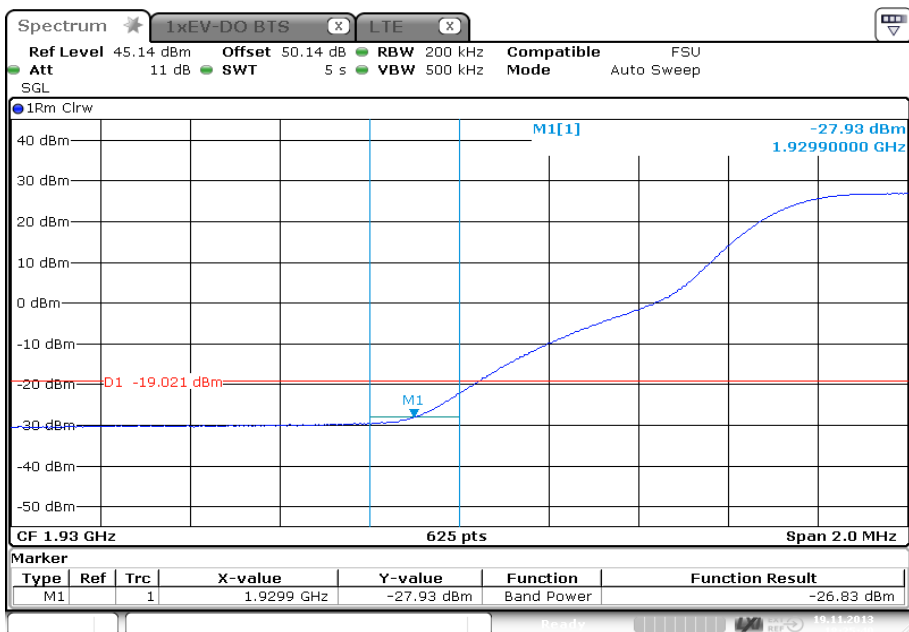

Date: 19.NOV.2013 18:25:40

Channel Position B - Bandwidth 20.0 MHz

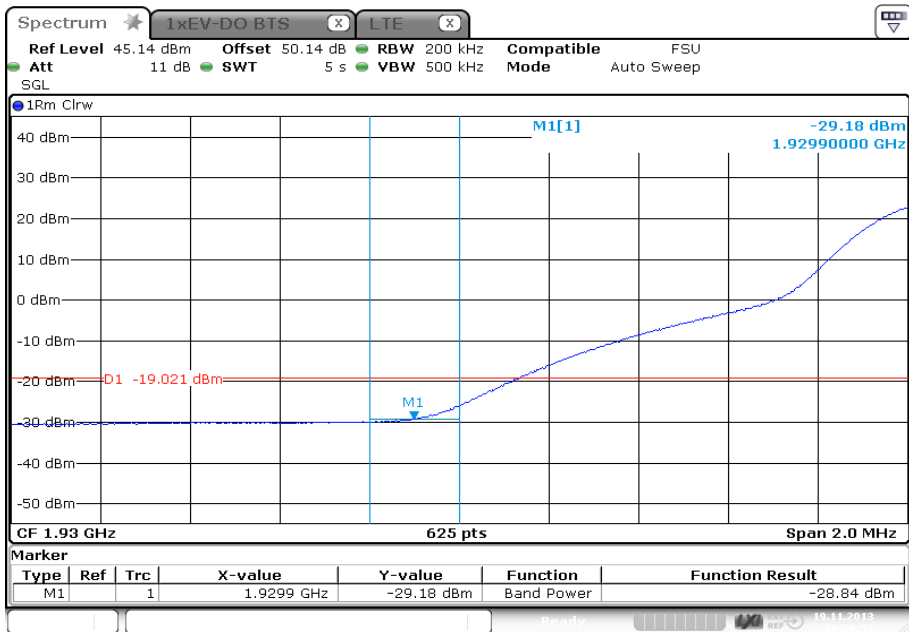

Date: 19.NOV.2013 18:28:52

Channel Position T - Bandwidth 5.0 MHz

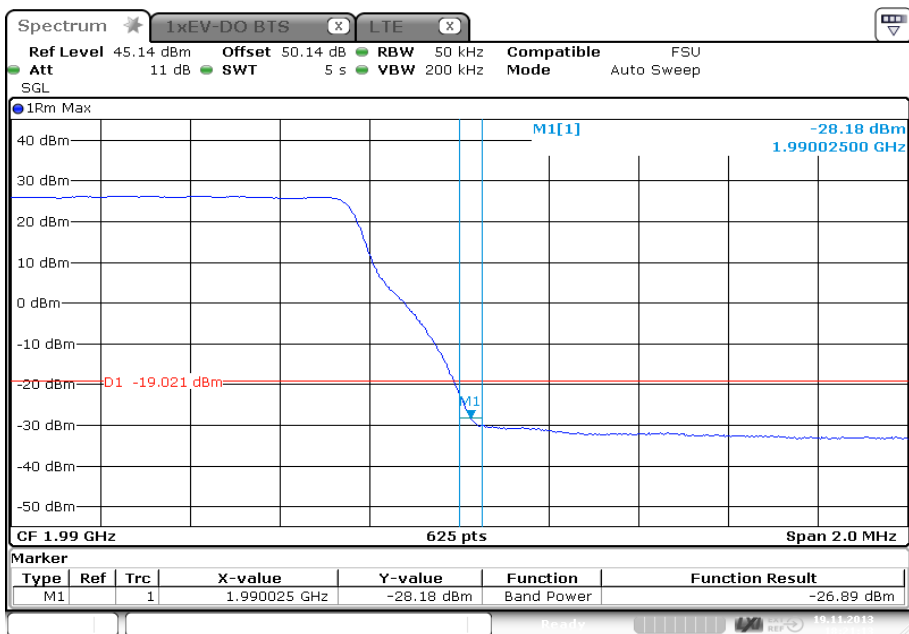

Date: 19.NOV.2013 18:21:13

Channel Position T - Bandwidth 10.0 MHz

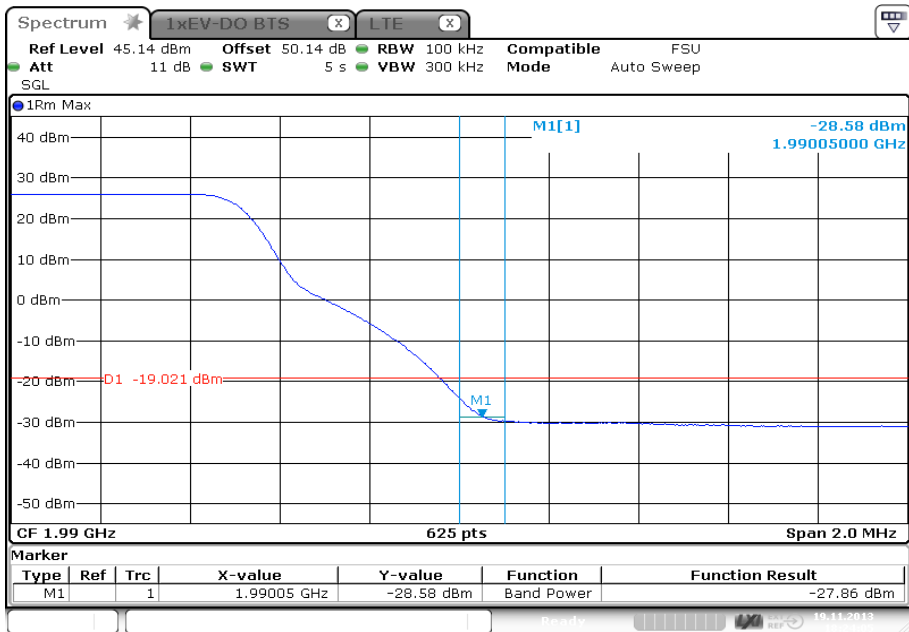

Date: 19.NOV.2013 18:24:05

Channel Position T - Bandwidth 15.0 MHz

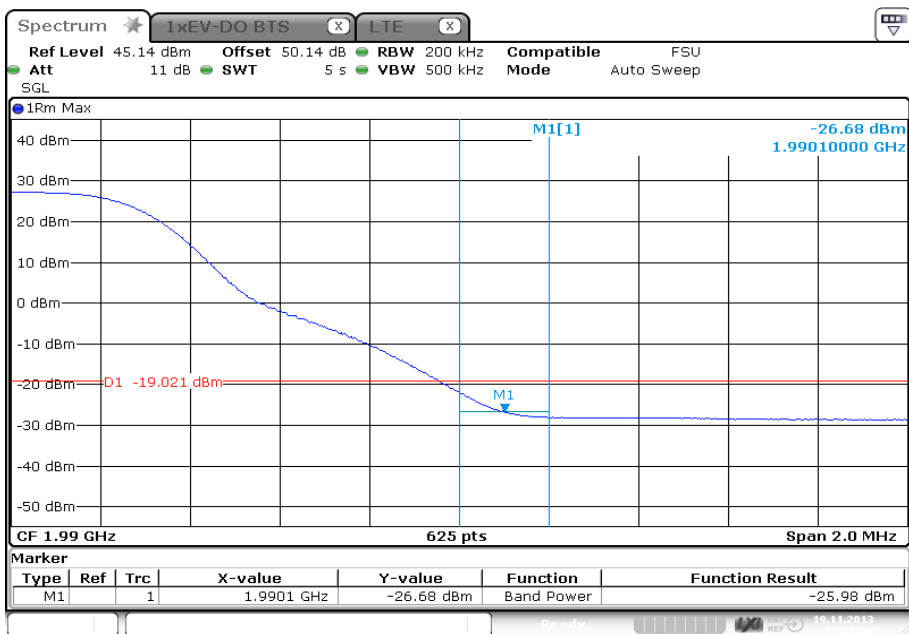

Date: 19.NOV.2013 18:27:06

Channel Position T - Bandwidth 20.0 MHz

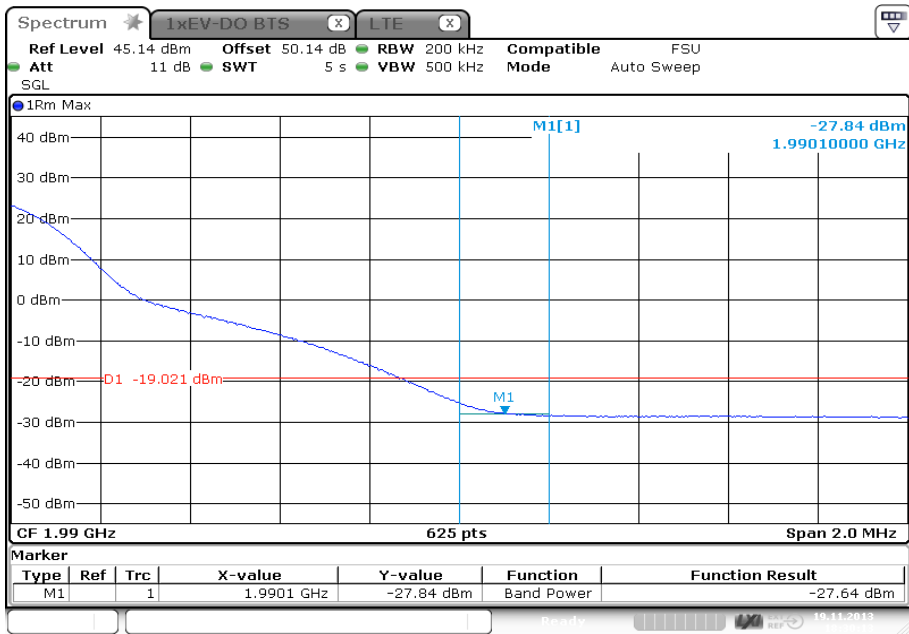

Date: 19.NOV.2013 18:30:12

Configuration LTE-MC1 (See Table 2 for carrier frequency)

Maximum Output Power 43 dBm per carrier, Test Model 1.1

Carrier Bandwidth	Band Edge (MHz)	
	Channel Position B	Channel Position T
5.0 MHz	1932.50 + 1937.50	1982.50 + 1987.50
10.0 MHz	1935.00 + 1945.00	1975.00 + 1985.00
15.0 MHz	1937.50 + 1952.50	1967.50 + 1982.50
20.0 MHz	1940.00 + 1960.00	1960.00 + 1980.00

Remarks

The channels shown in the table above are the minimum and maximum channels that can be used in the authorised frequency ranges to maintain compliance. Channels outside of the ranges shown in the above tables shall not be made available to the end user.

Channel Position B - Bandwidth 5.0 MHz

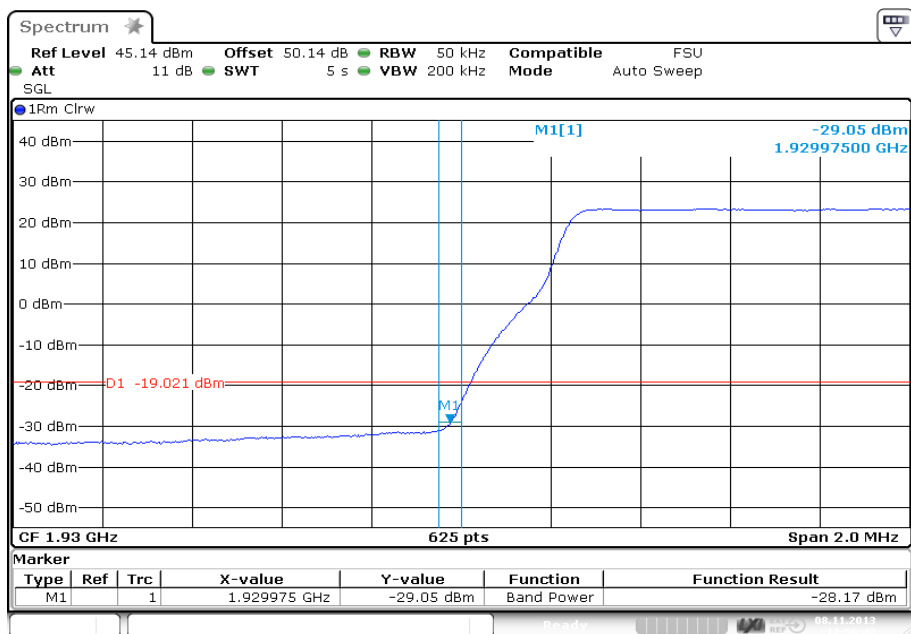

Date: 8.NOV.2013 12:56:43

Channel Position B - Bandwidth 10.0 MHz

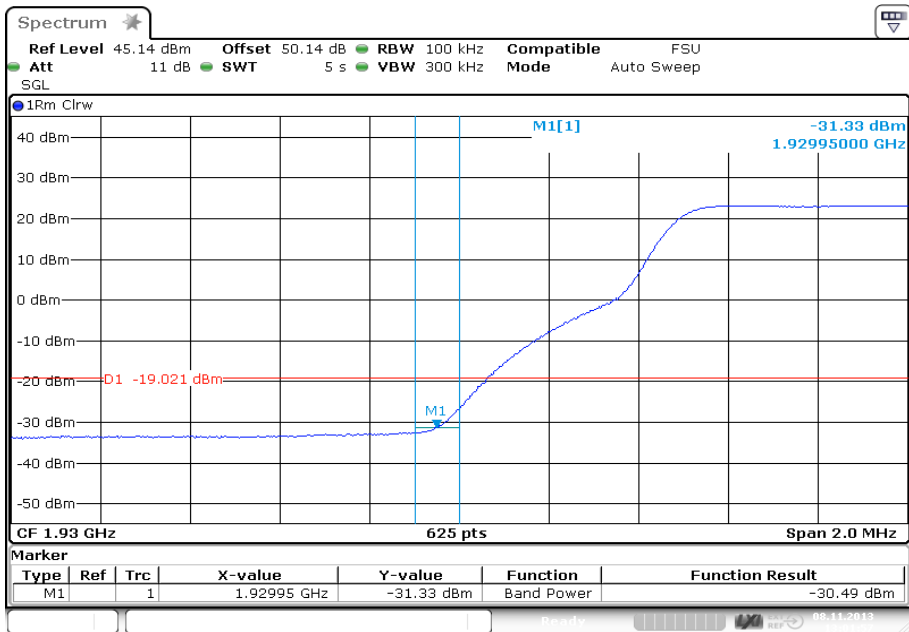

Date: 8.NOV.2013 13:01:57

Channel Position B - Bandwidth 15.0 MHz

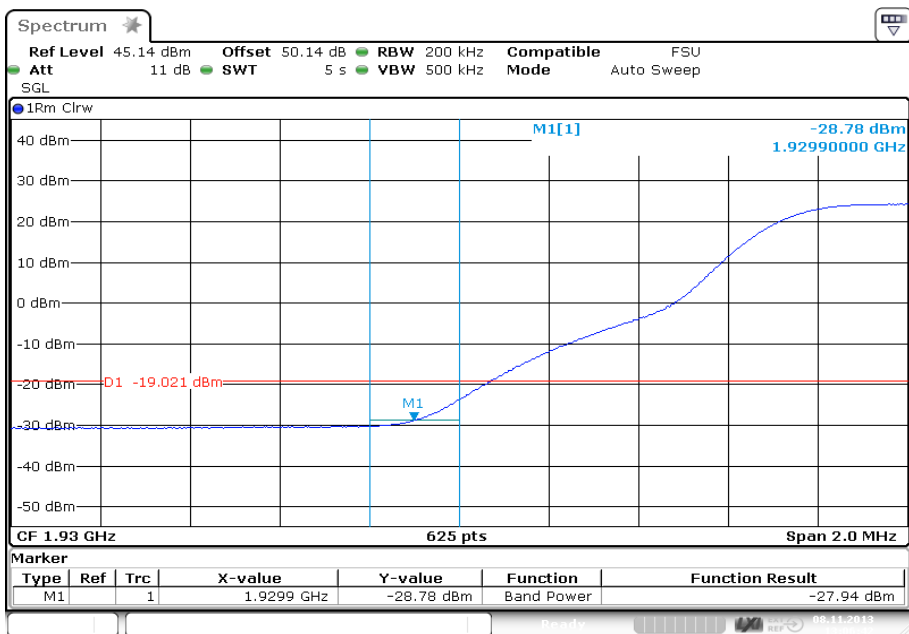

Date: 8.NOV.2013 13:06:43

Channel Position B - Bandwidth 20.0 MHz

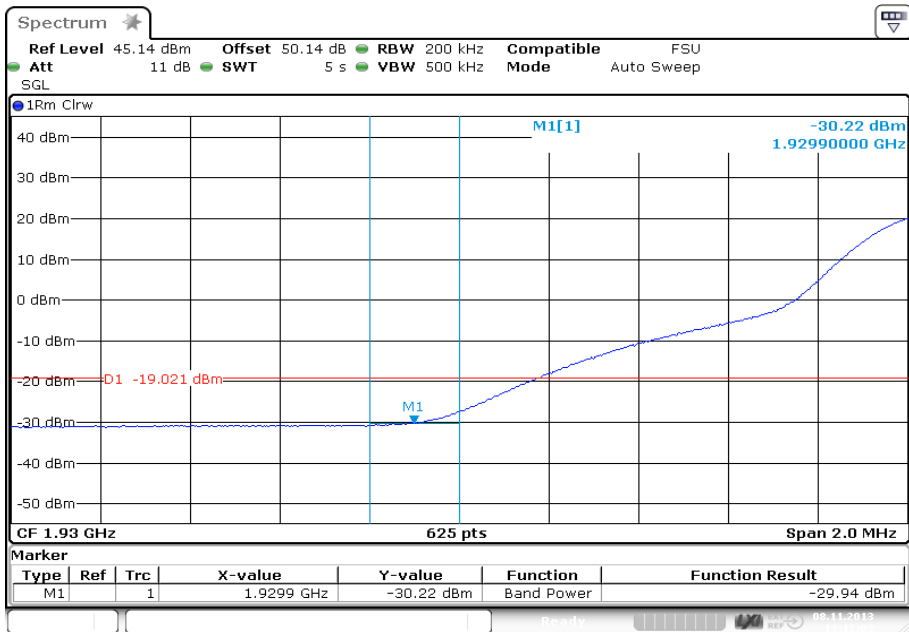

Date: 8.NOV.2013 13:12:04

Channel Position T - Bandwidth 5.0 MHz

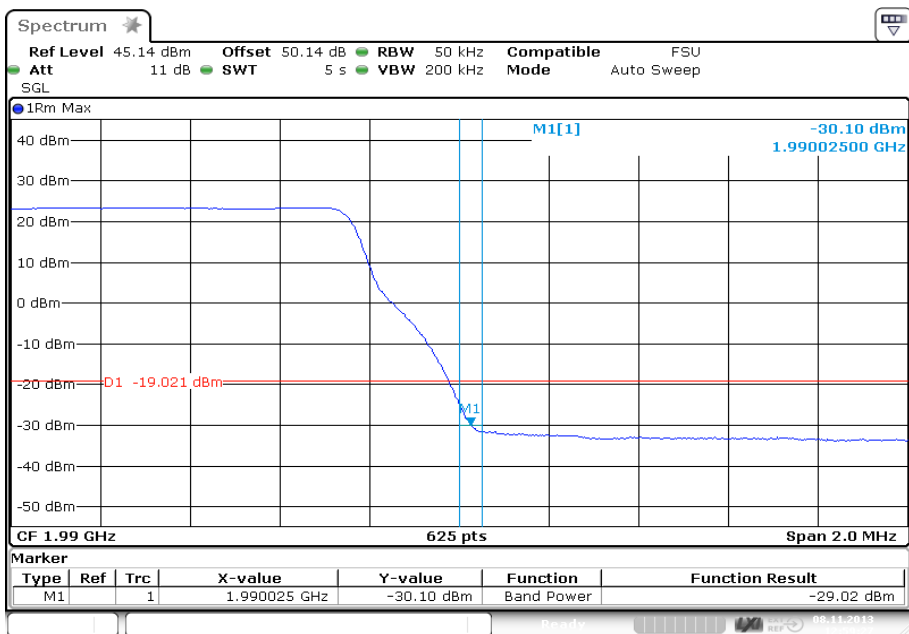

Date: 8.NOV.2013 12:59:27

Channel Position T - Bandwidth 10.0 MHz

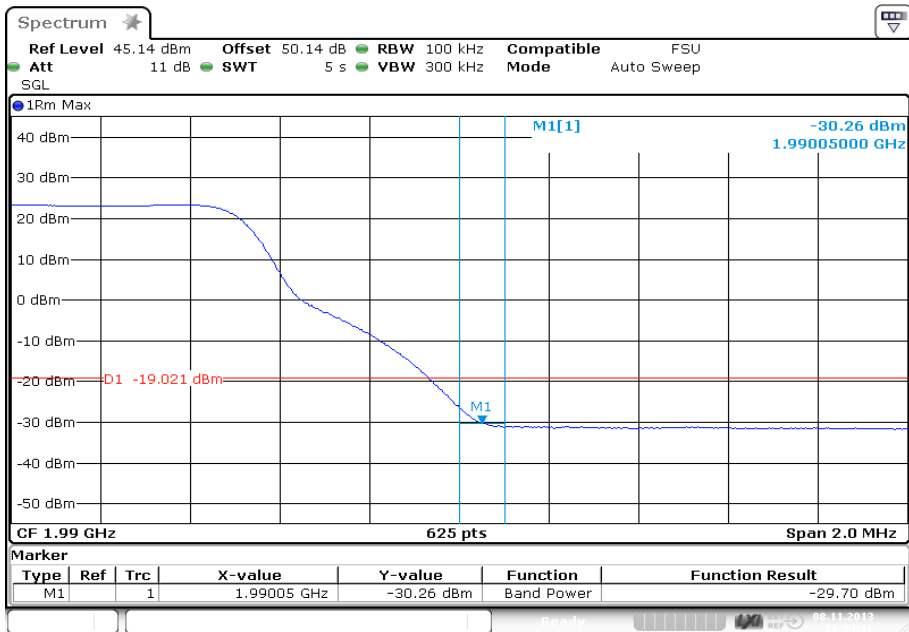

Date: 8.NOV.2013 13:04:19

Channel Position T - Bandwidth 15.0 MHz

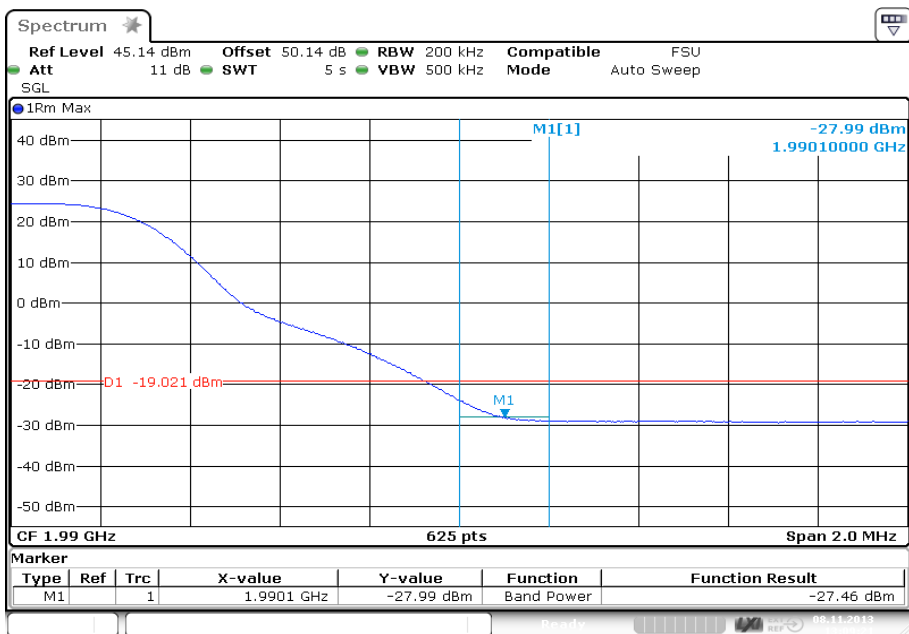

Date: 8.NOV.2013 13:09:21

Channel Position T - Bandwidth 20.0 MHz

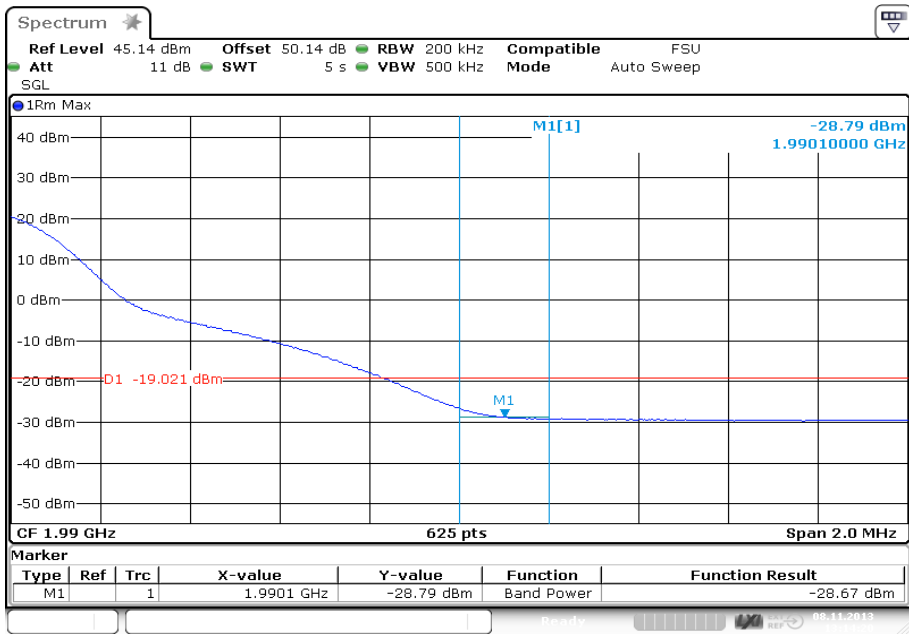

Date: 8.NOV.2013 13:14:20

Configuration CDMA-SC (See Table 2 for carrier frequency)

Maximum Output Power 46 dBm per carrier

Modulation	Band Edge (MHz)	
	Channel Position B	Channel Position T
QPSK	1931.25	1988.75
8PSK	1931.25	1988.75
16QAM	1931.25	1988.75

Remarks

The channels shown in the table above are the minimum and maximum channels that can be used in the authorised frequency ranges to maintain compliance. Channels outside of the ranges shown in the above tables shall not be made available to the end user.

Channel Position B - Modulation QPSK

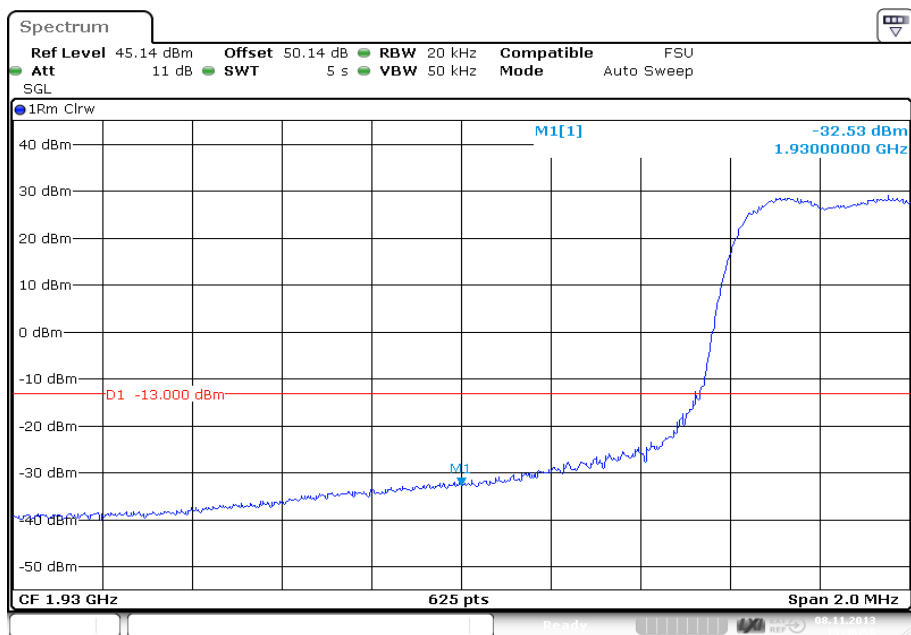

Date: 8.NOV.2013 15:46:58

Channel Position B - Modulation 8PSK

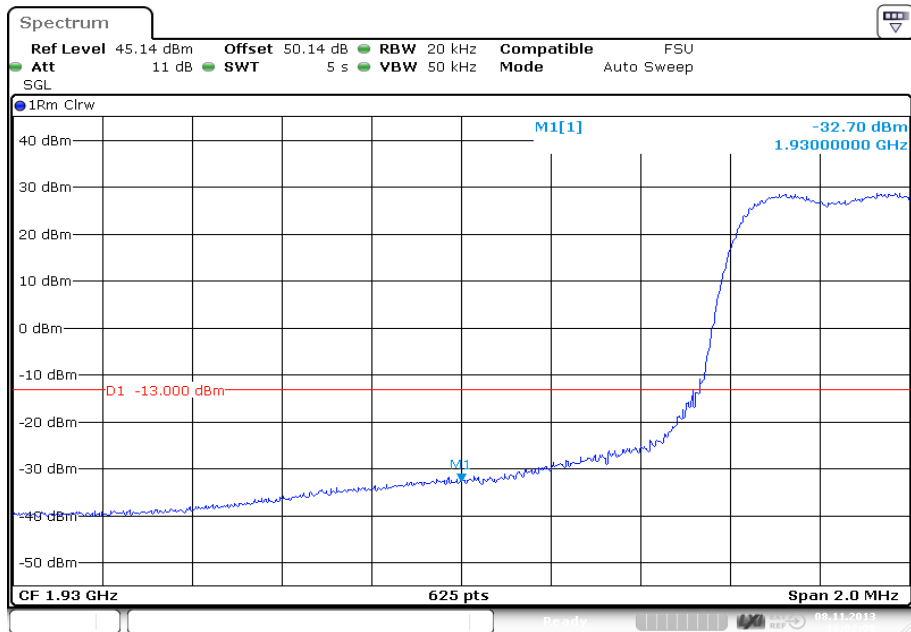

Channel Position B - Modulation 16QAM

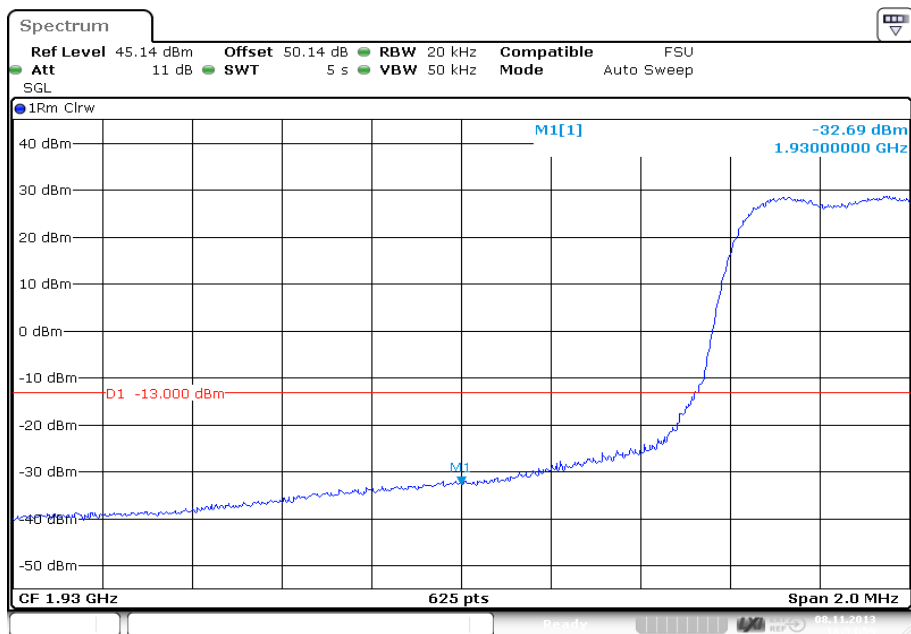

Channel Position T - Modulation QPSK

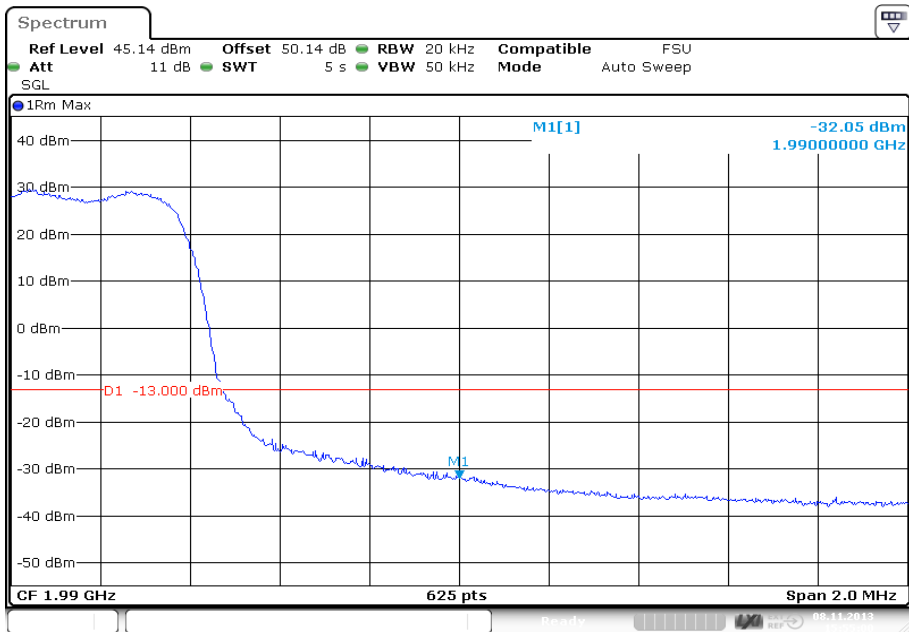

Date: 8.NOV.2013 15:55:01

Channel Position T - Modulation 8PSK

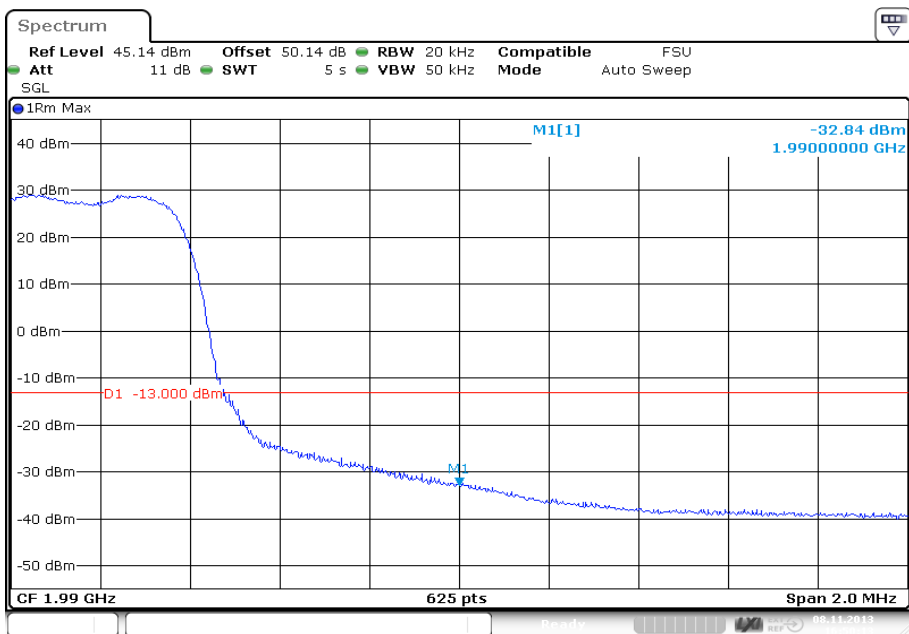

Date: 8.NOV.2013 16:50:14

Channel Position T - Modulation 16QAM

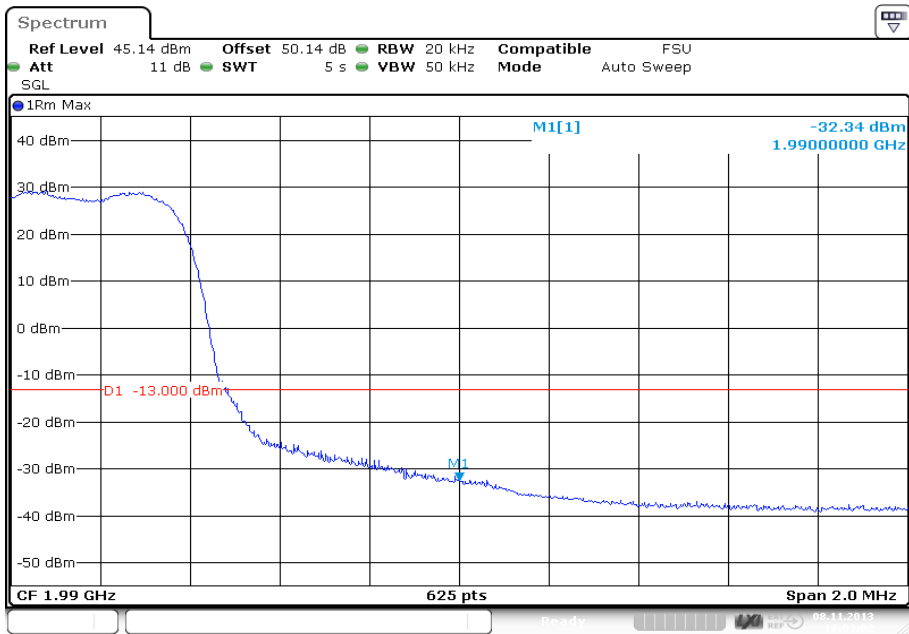

Date: 8.NOV.2013 17:03:02

Configuration CDMA-MC1 (See Table 2 for carrier frequency)

Maximum Output Power 43 dBm per carrier

Modulation	Band Edge (MHz)	
	Channel Position B	Channel Position T
QPSK	1931.25 + 1932.50	1987.50 + 1988.75
8PSK	1931.25 + 1932.50	1987.50 + 1988.75
16QAM	1931.25 + 1932.50	1987.50 + 1988.75

Remarks

The channels shown in the table above are the minimum and maximum channels that can be used in the authorised frequency ranges to maintain compliance. Channels outside of the ranges shown in the above tables shall not be made available to the end user.

Channel Position B - Modulation QPSK

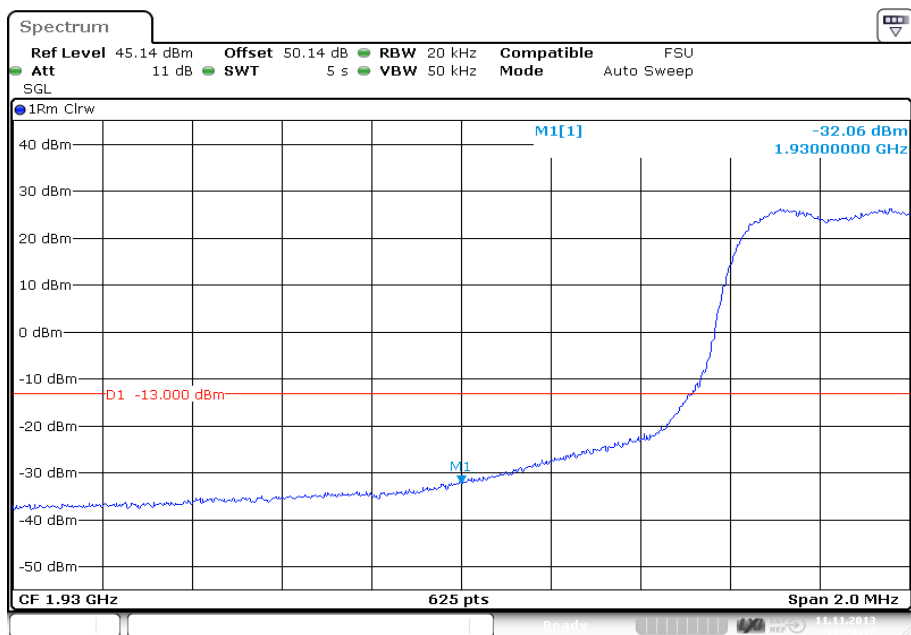

Date: 11.NOV.2013 12:23:17

Channel Position B - Modulation 8PSK

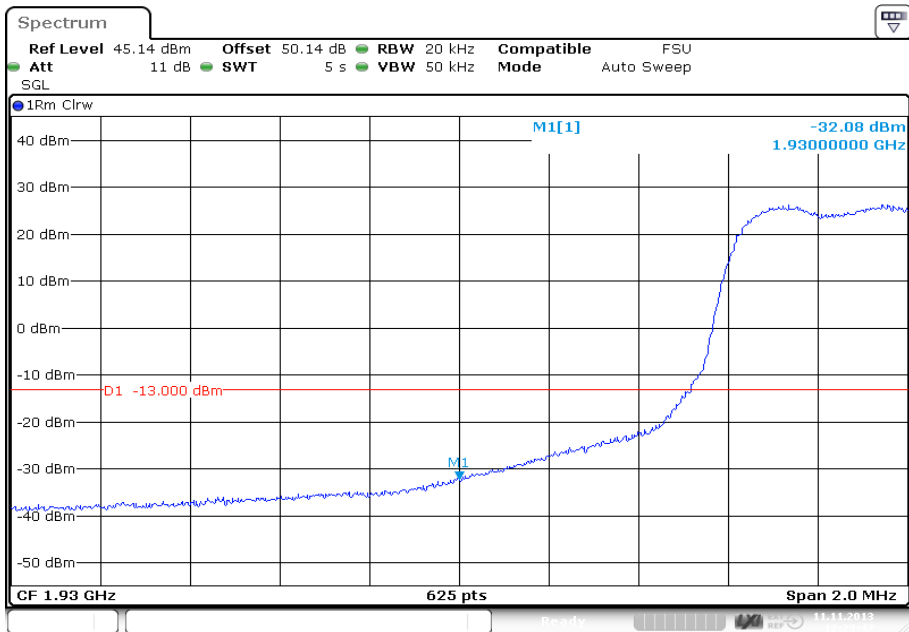

Date: 11.NOV.2013 12:29:47

Channel Position B - Modulation 16QAM

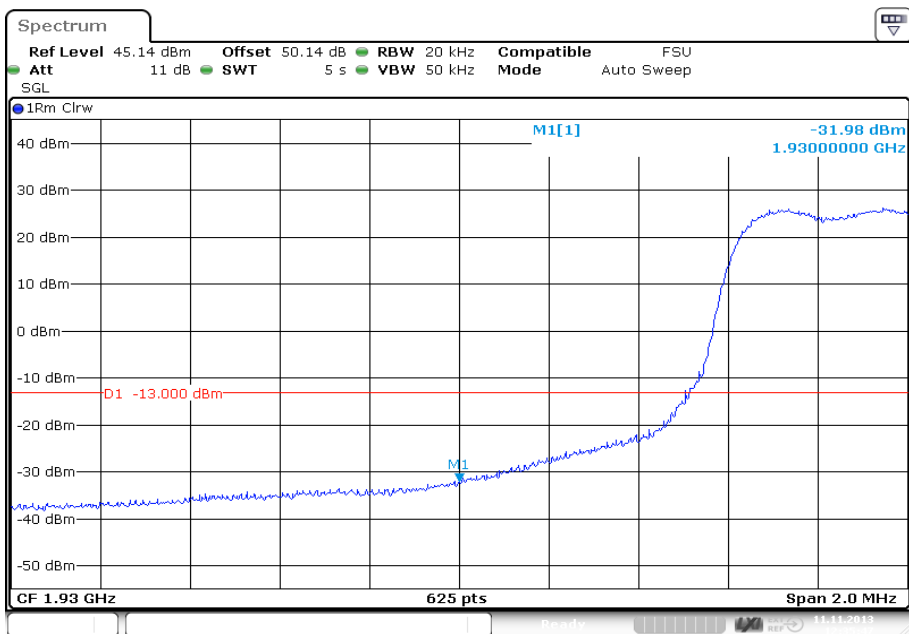

Date: 11.NOV.2013 12:35:48

Channel Position T - Modulation QPSK

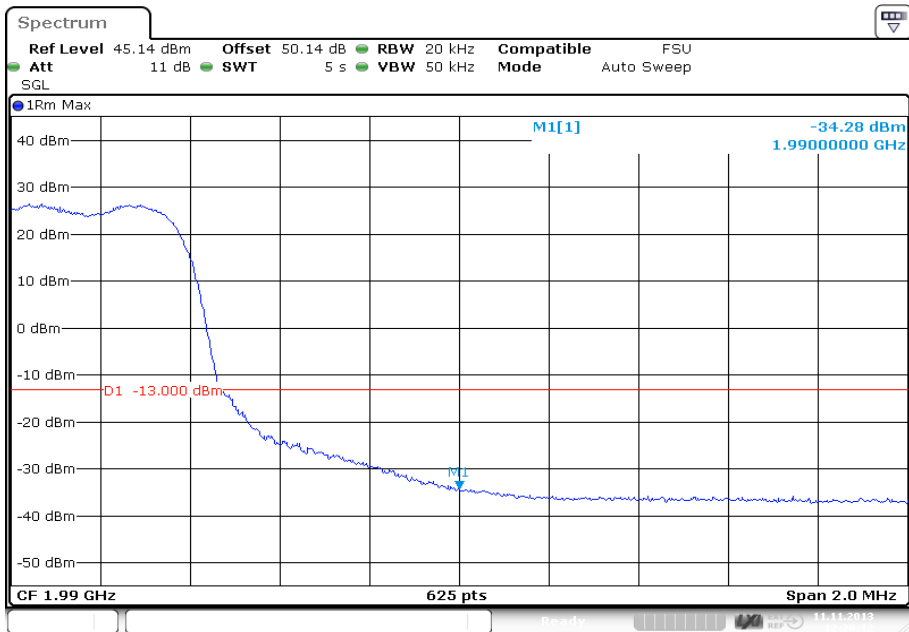

Date: 11.NOV.2013 12:26:13

Channel Position T - Modulation 8PSK

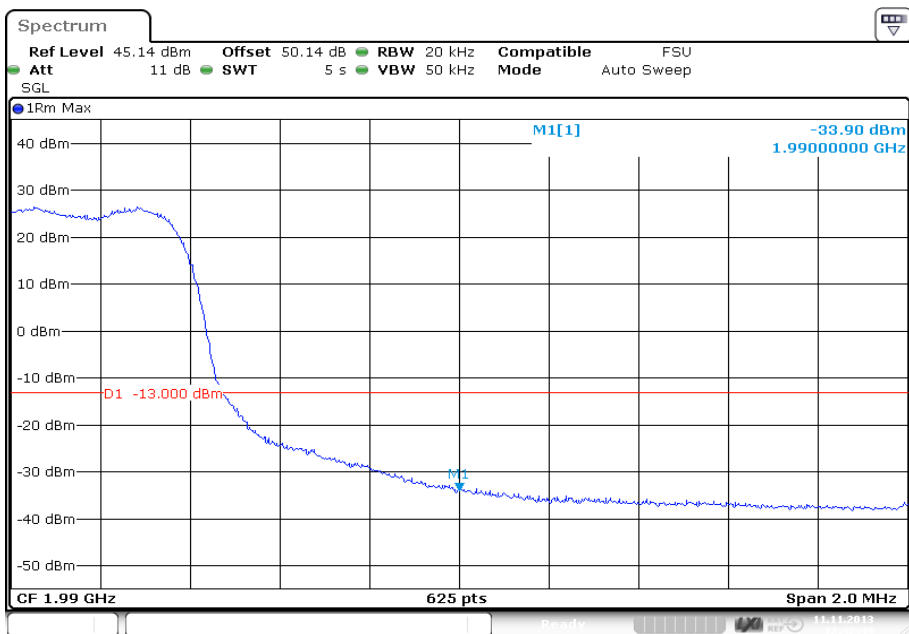

Date: 11.NOV.2013 12:32:49

Channel Position T - Modulation 16QAM

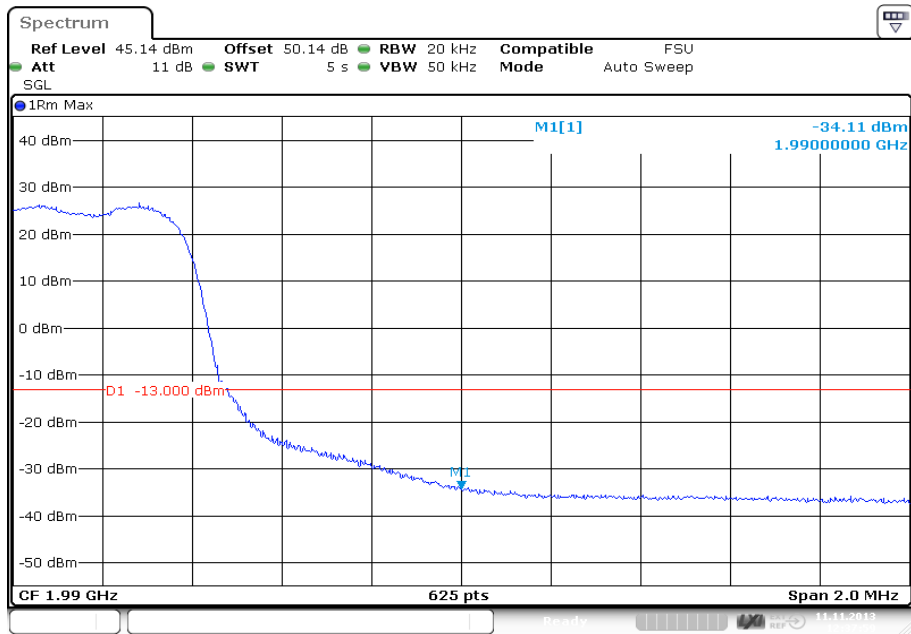

Date: 11.NOV.2013 12:37:59

Configuration LTE+CDMA-MC1 (See Table 1 for carrier frequency)

Maximum Output Power 43 dBm per carrier

CDMA Modulation / LTE Bandwidth	Band Edge (MHz)	
	Channel Position BRFBW	Channel Position TRFBW
QPSK / 15.0 MHz	1931.25 (CDMA) + 1939.40 (LTE)	1980.60 (LTE) + 1988.75 (CDMA)

Remarks

The channels shown in the table above are the minimum and maximum channels that can be used in the authorised frequency ranges to maintain compliance. Channels outside of the ranges shown in the above tables shall not be made available to the end user.

Channel Position BRFBW - CDMA Modulation QPSK / LTE Test Model 1.1 / Bandwidth 15.0 MHz

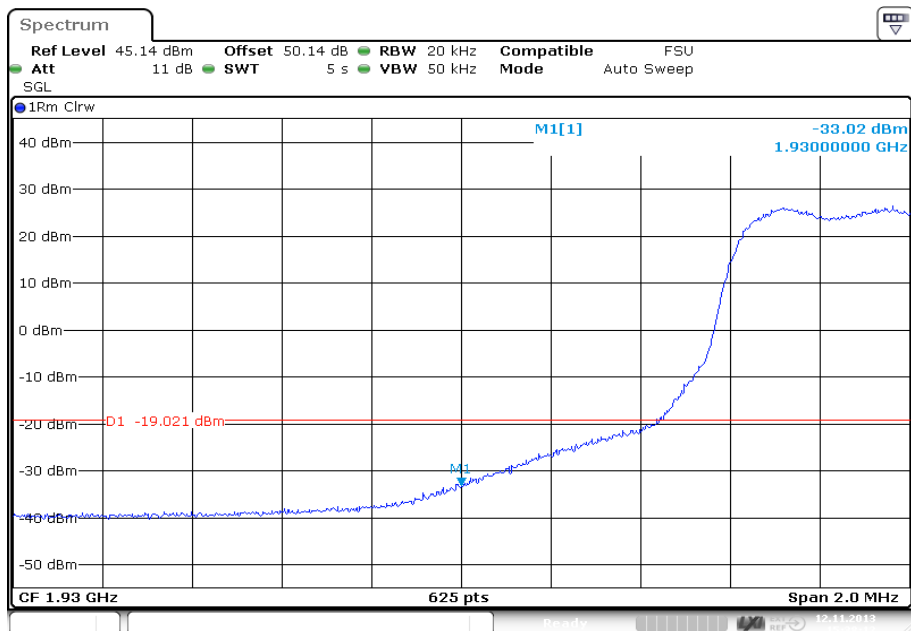

Date: 12.NOV.2013 15:38:12

Channel Position TRFBW - CDMA Modulation QPSK / LTE Test Model 1.1 / Bandwidth 15.0 MHz

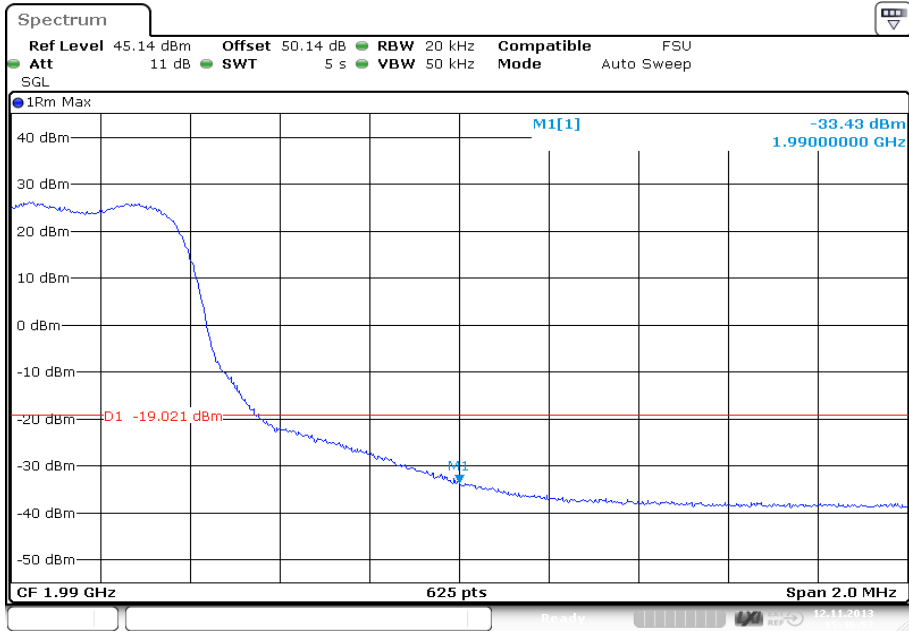

Date: 12.NOV.2013 15:46:58

Limit	Level
Single Port	-13 dBm
2 Port MIMO	-16 dBm
4 Port MIMO	-19 dBm

2.4 CONDUCTED SPURIOUS EMISSIONS

2.4.1 Specification Reference

FCC CFR 47 Part 2, Clause 2.1051
FCC CFR 47 Part 24, Clause 24.238(a)
Industry Canada RSS-133, Clause 6.5

2.4.2 Date of Test and Modification State

08, 11, 13 and 14 November 2013 - Modification State 0

2.4.3 Test Equipment Used

The major items of test equipment used for the above tests are identified in Section 3.1.

2.4.4 Environmental Conditions

Ambient Temperature	23.1 - 24.9°C
Relative Humidity	34.2 - 42.7%

2.4.5 Test Method

The EUT was connected to a Spectrum Analyser via 50dB of attenuation for measurements below 3.5GHz and up to 20GHz using 30dB of attenuation and a high pass filter. Prior to testing, a Network Analyser was used to calibrate the path loss between the EUT and the Spectrum Analyser. The worst case path loss in the measured ranges was entered as a reference level offset. Over the measured ranges, the RBW was set to 1MHz with a VBW of 3MHz. All measurement results are specified as average with an RMS detector being used in conjunction with a trace setting of Max Hold. Measurements were performed in configurations of the EUT as reported below. The configurations chosen were worst case based on pre-test results carried out prior to the start of testing.

Testing was performed on all ports with the test results for Port A being recorded. The test limits were reduced from the specification limit of $43+10\log(P)$ by a factor of $10\log(4)$ in accordance with KDB 662911 D01 v02r01 to cover all transmit configurations, (1 Port, 2 Port MIMO and 4 Port MIMO configurations). This equated to a limit of -19dBm, (worst case).

When in CDMA single-RAT, it is not possible to operate in a MIMO mode and therefore the limit of $43+10\log(P) = -13\text{dBm}$ was used.

The results are shown in the plots below.

2.4.6 Test Results

Configuration LTE-SC (See Table 1 for carrier frequency)

Maximum Output Power 46 dBm per carrier, Test Model 1.1

Channel Position B - Carrier Bandwidth 5.0 MHz - Band 1 - Range 0.009 to 3500 MHz

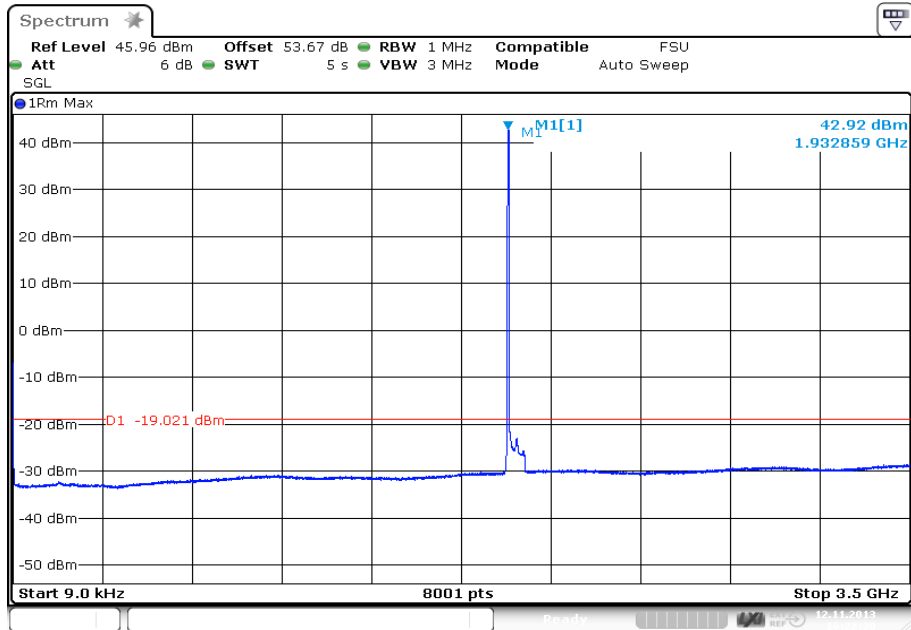

Channel Position B - Carrier Bandwidth 5.0 MHz - 1930 MHz - 1990 MHz - Range 3500 to 12000 MHz

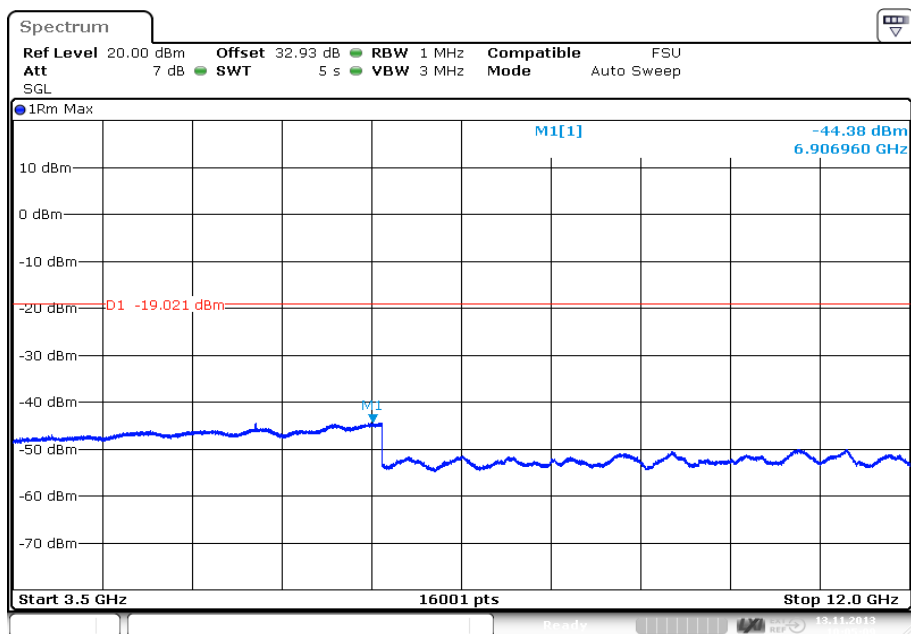

Channel Position B - Carrier Bandwidth 5.0 MHz - Band 3 - Range 12000 to 20000 MHz

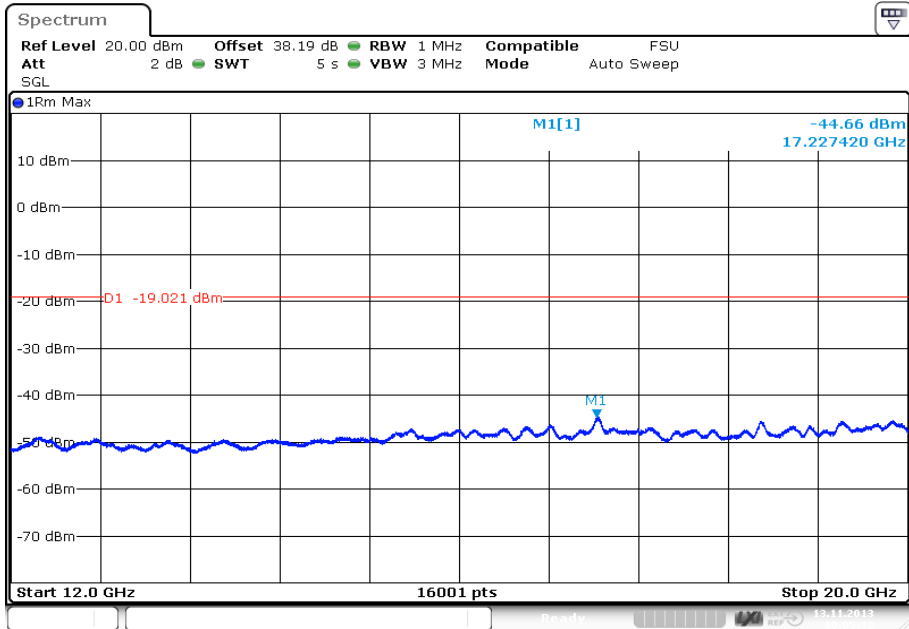

Channel Position B - Carrier Bandwidth 20.0 MHz - Band 1 - Range 0.009 to 3500 MHz

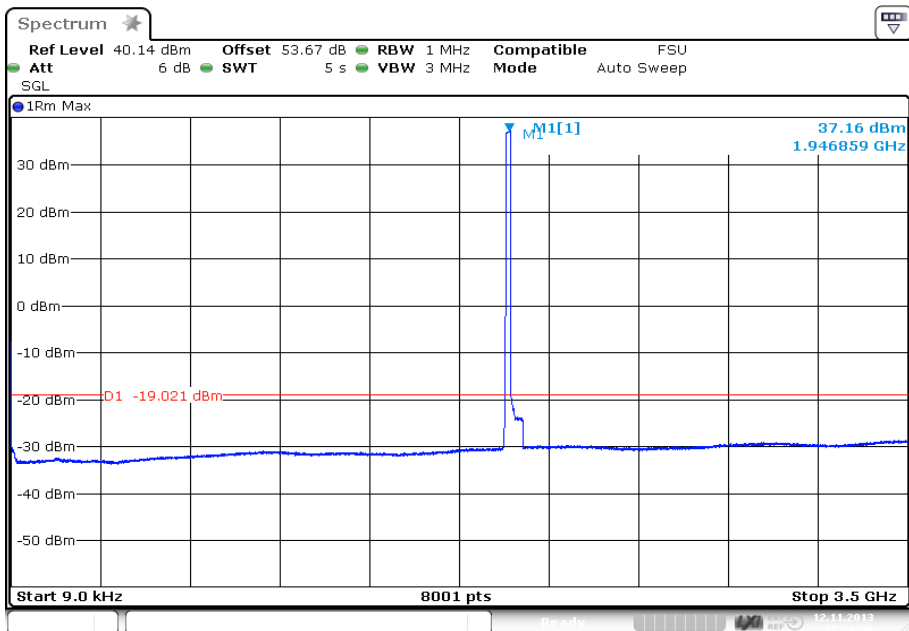

Channel Position B - Carrier Bandwidth 20.0 MHz - 1930 MHz - 1990 MHz - Range 3500 to 12000 MHz

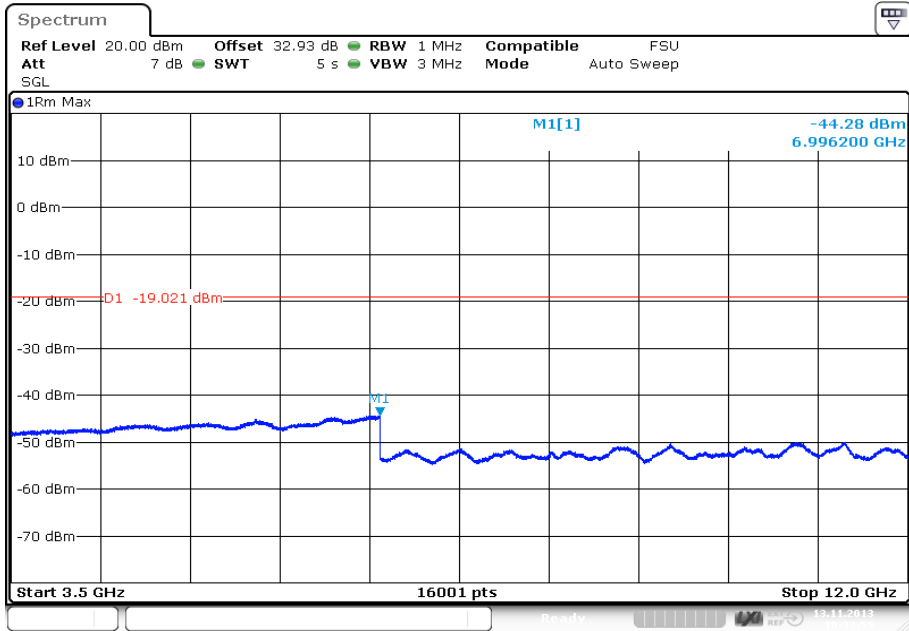

Date: 13.NOV.2013 10:33:55

Channel Position B - Carrier Bandwidth 20.0 MHz - Band 3 - Range 12000 to 20000 MHz

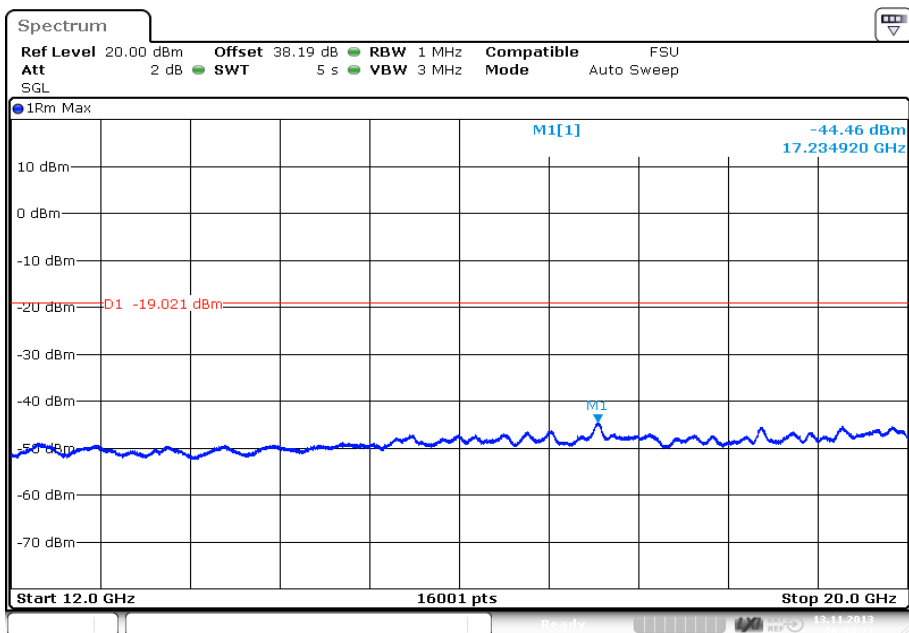

Date: 13.NOV.2013 10:34:21

Channel Position M - Carrier Bandwidth 5.0 MHz - Band 1 - Range 0.009 to 3500 MHz

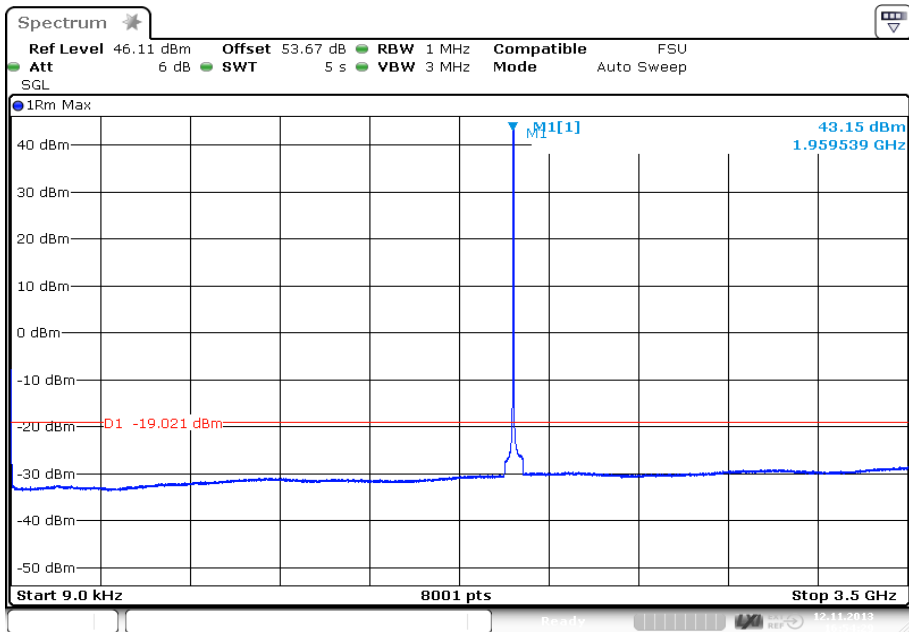

Date: 12.NOV.2013 16:54:30

Channel Position M - Carrier Bandwidth 5.0 MHz - 1930 MHz - 1990 MHz - Range 3500 to 12000 MHz

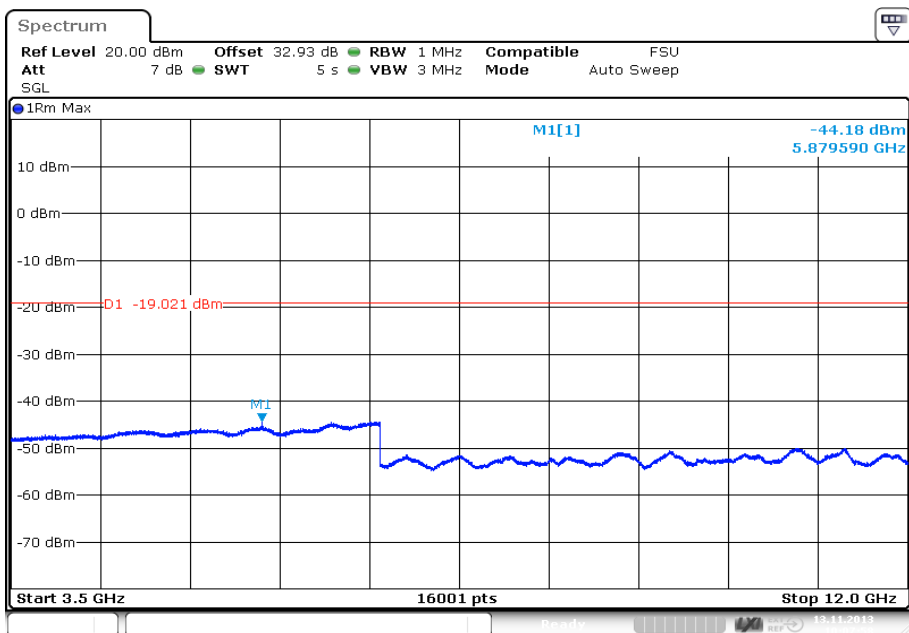

Date: 13.NOV.2013 10:07:59

Channel Position M - Carrier Bandwidth 5.0 MHz - Band 3 - Range 12000 to 20000 MHz

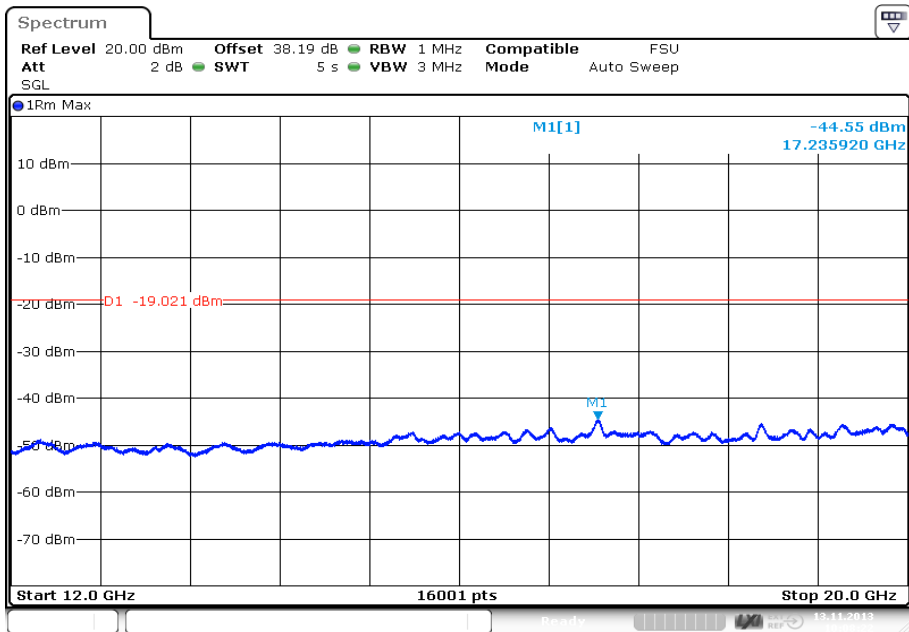

Date: 13.NOV.2013 10:08:22

Channel Position M - Carrier Bandwidth 20.0 MHz - Band 1 - Range 0.009 to 3500 MHz

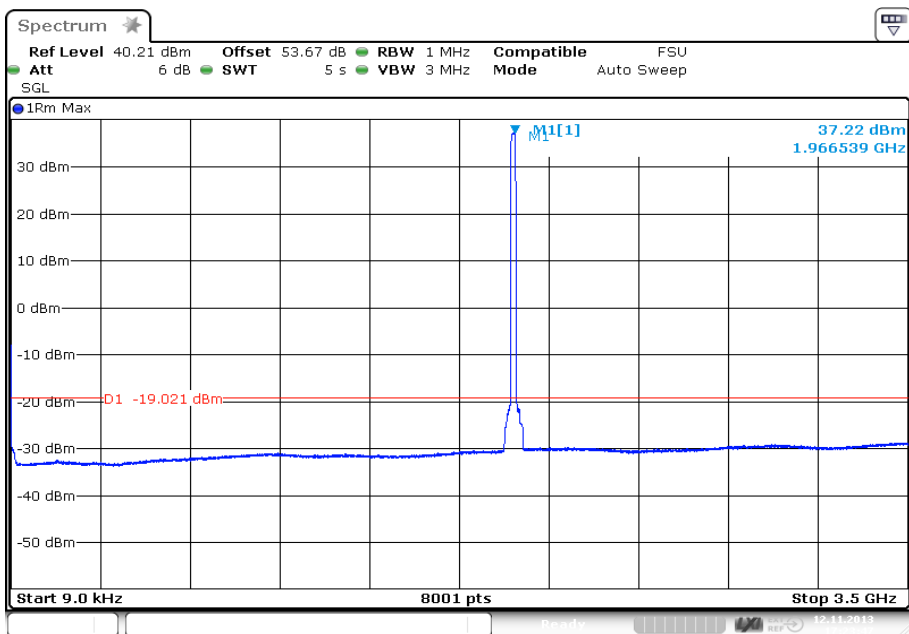

Date: 12.NOV.2013 17:23:48

Channel Position M - Carrier Bandwidth 20.0 MHz - 1930 MHz - 1990 MHz - Range 3500 to 12000 MHz

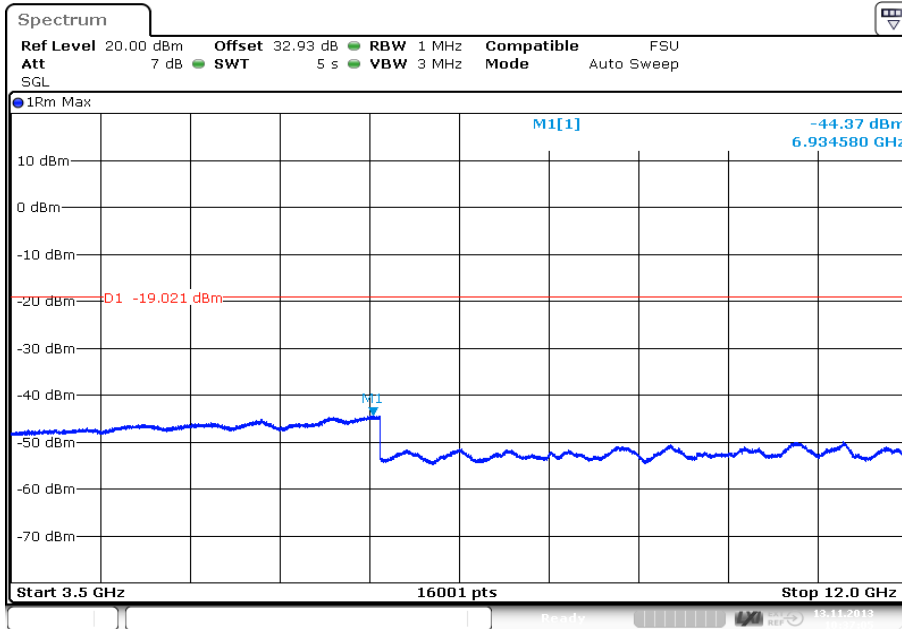

Date: 13.NOV.2013 10:37:06

Channel Position M - Carrier Bandwidth 20.0 MHz - Band 3 - Range 12000 to 20000 MHz

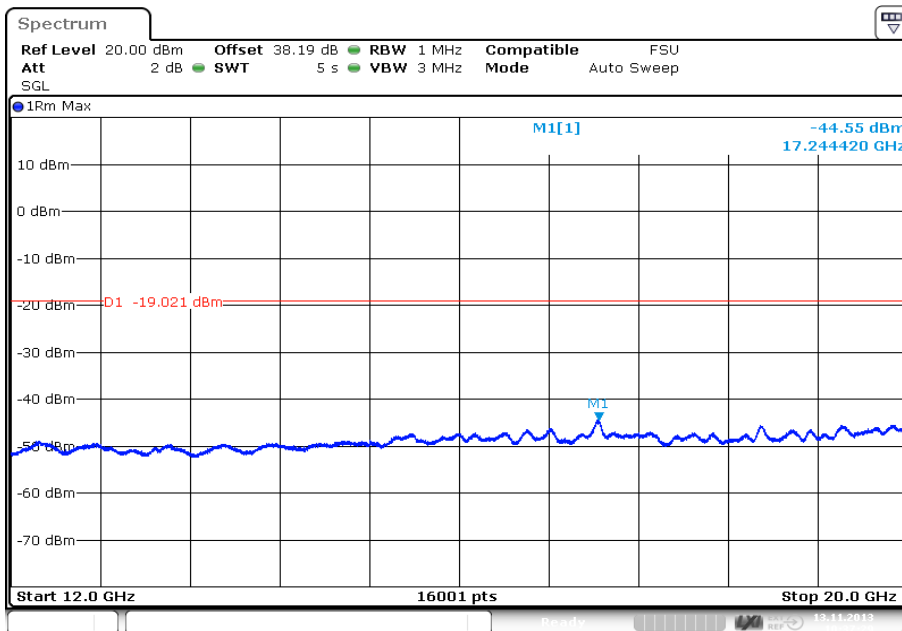

Date: 13.NOV.2013 10:37:30

Channel Position T - Carrier Bandwidth 5.0 MHz - Band 1 - Range 0.009 to 3500 MHz

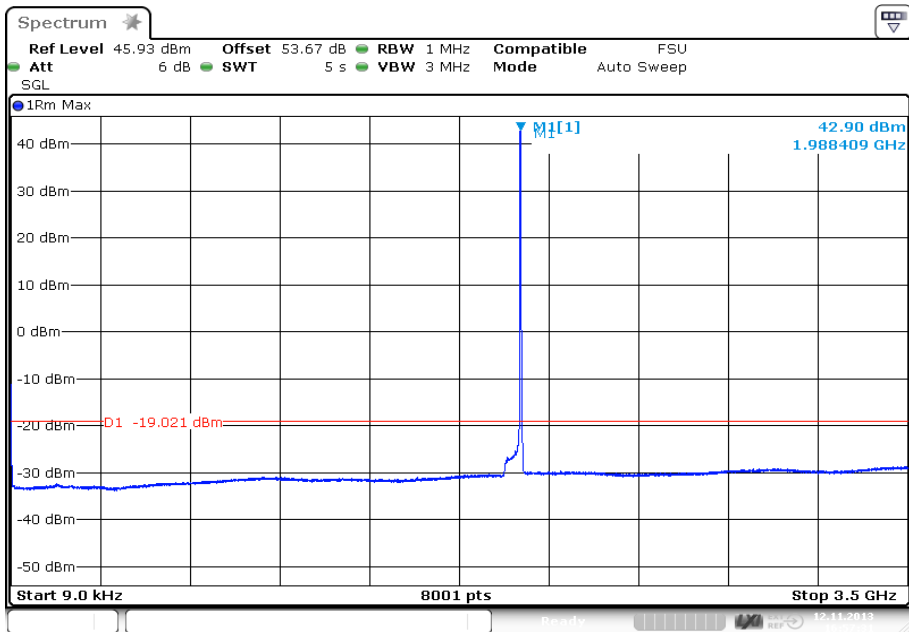

Date: 12.NOV.2013 16:57:31

Channel Position T - Carrier Bandwidth 5.0 MHz - 1930 MHz - 1990 MHz - Range 3500 to 12000 MHz

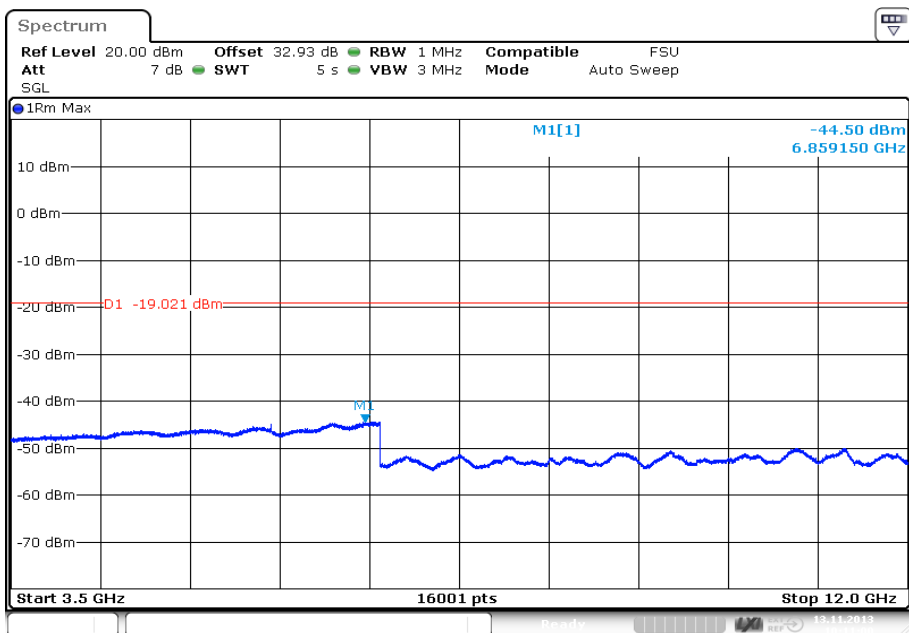

Date: 13.NOV.2013 10:11:00

Channel Position T - Carrier Bandwidth 5.0 MHz - Band 3 - Range 12000 to 20000 MHz

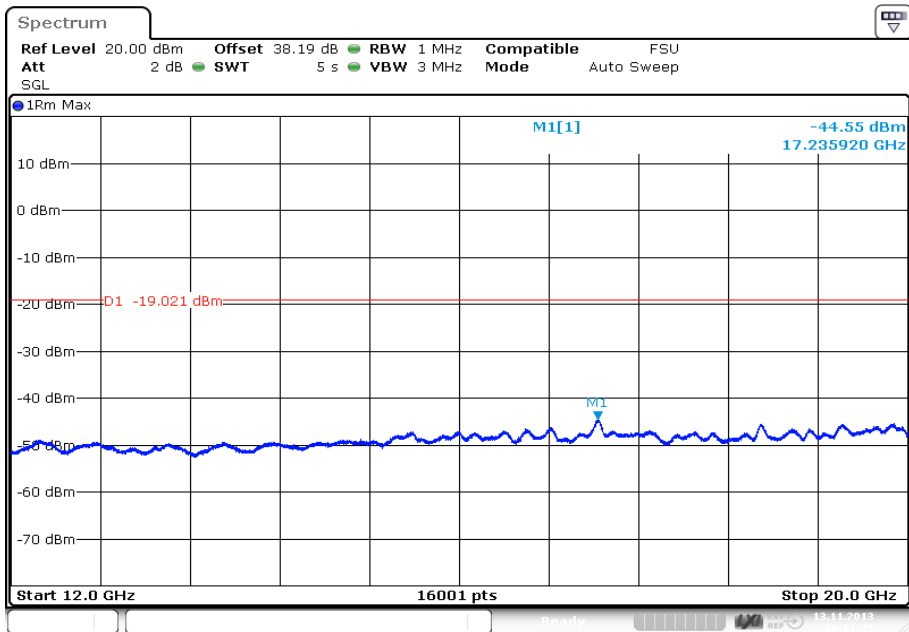

Date: 13.NOV.2013 10:11:26

Channel Position T - Carrier Bandwidth 20.0 MHz - Band 1 - Range 0.009 to 3500 MHz

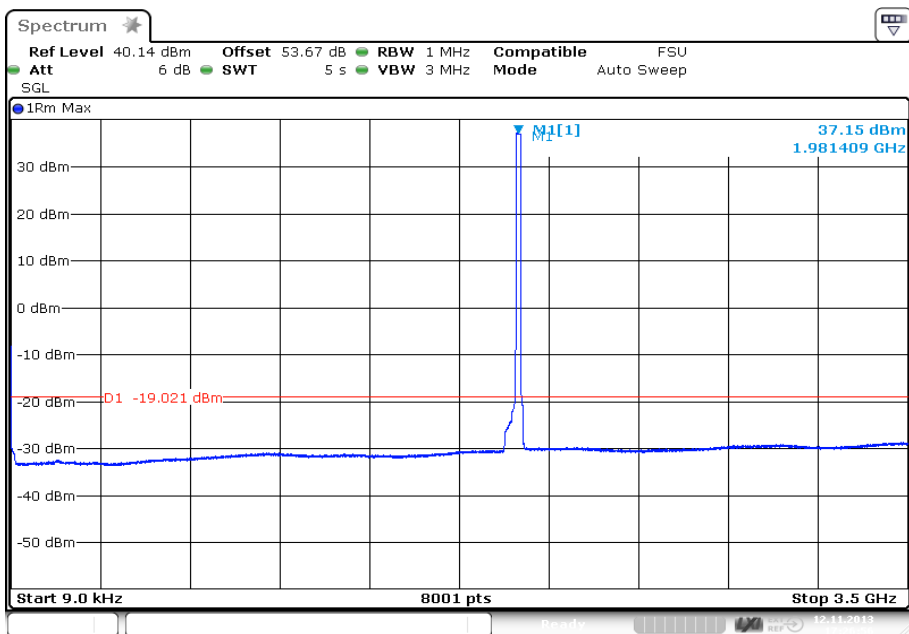

Date: 12.NOV.2013 17:26:56

Channel Position T - Carrier Bandwidth 20.0 MHz - 1930 MHz - 1990 MHz - Range 3500 to 12000 MHz

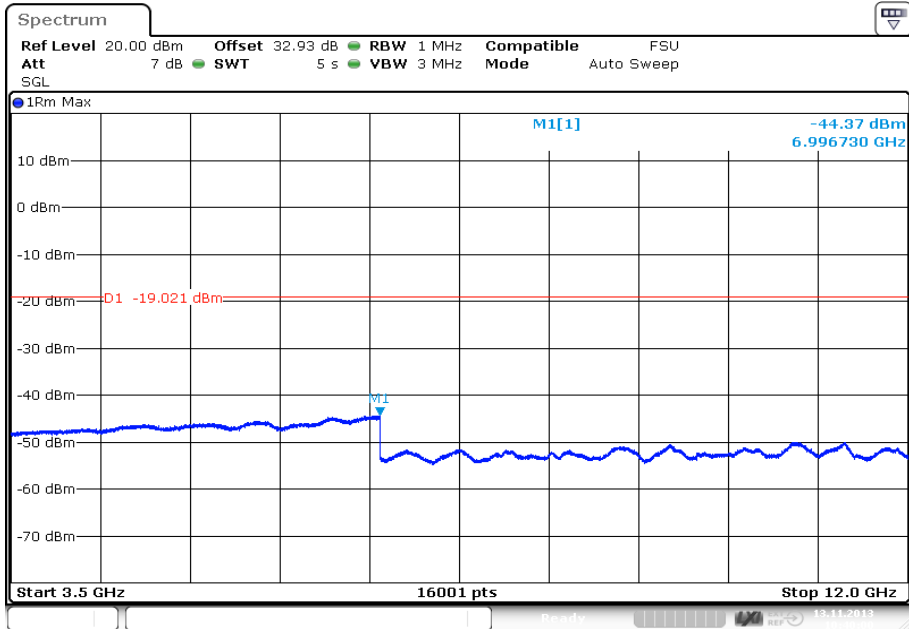

Channel Position T - Carrier Bandwidth 20.0 MHz - Band 3 - Range 12000 to 20000 MHz

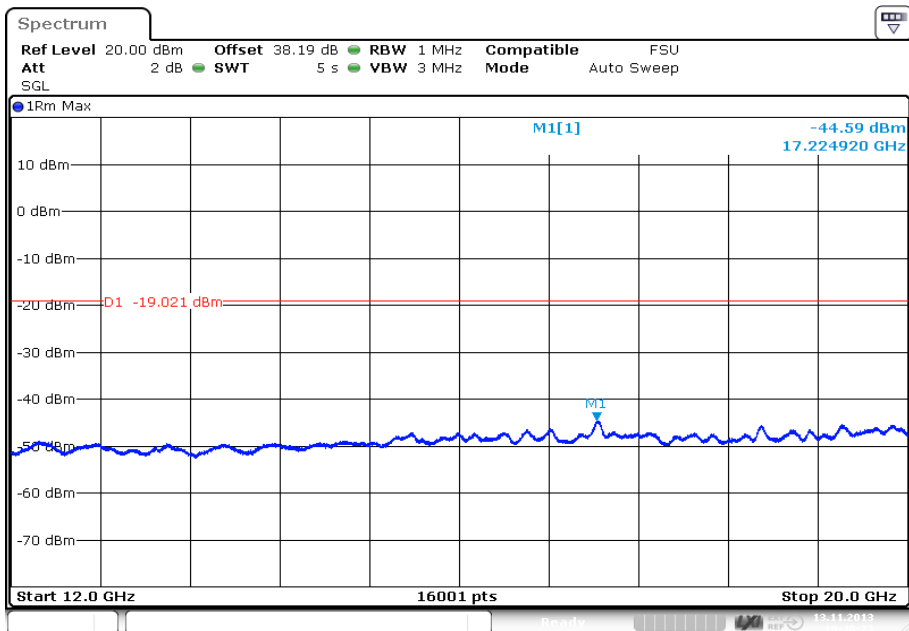

Configuration LTE-MC1 (See Table 1 for carrier frequency)

Maximum Output Power 43 dBm per carrier, Test Model 1.1

Channel Position M - Carrier Bandwidth 5.0 MHz - Band 1 - Range 0.009 to 3500 MHz

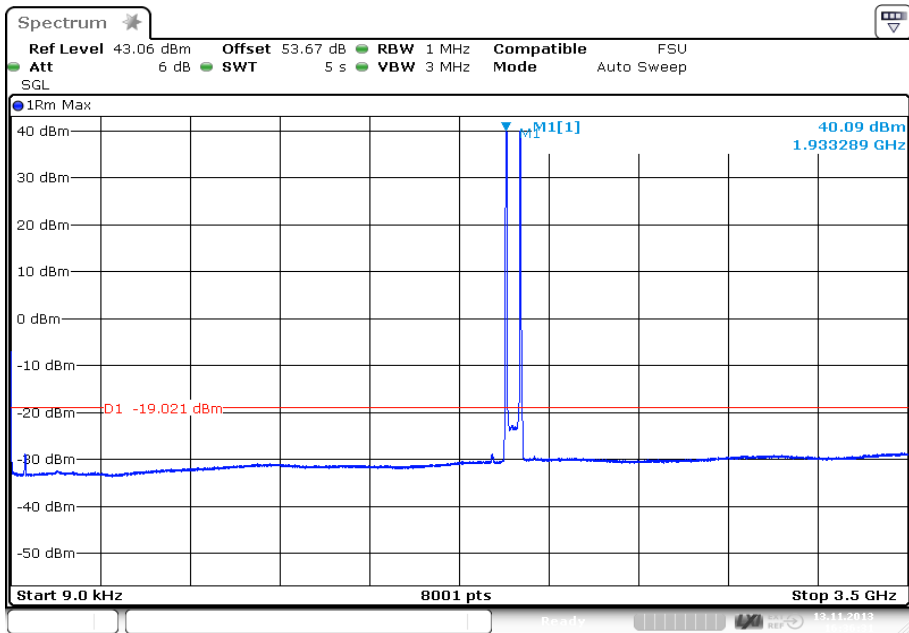

Channel Position M - Carrier Bandwidth 5.0 MHz - 1930 MHz - 1990 MHz - Range 3500 to 12000 MHz

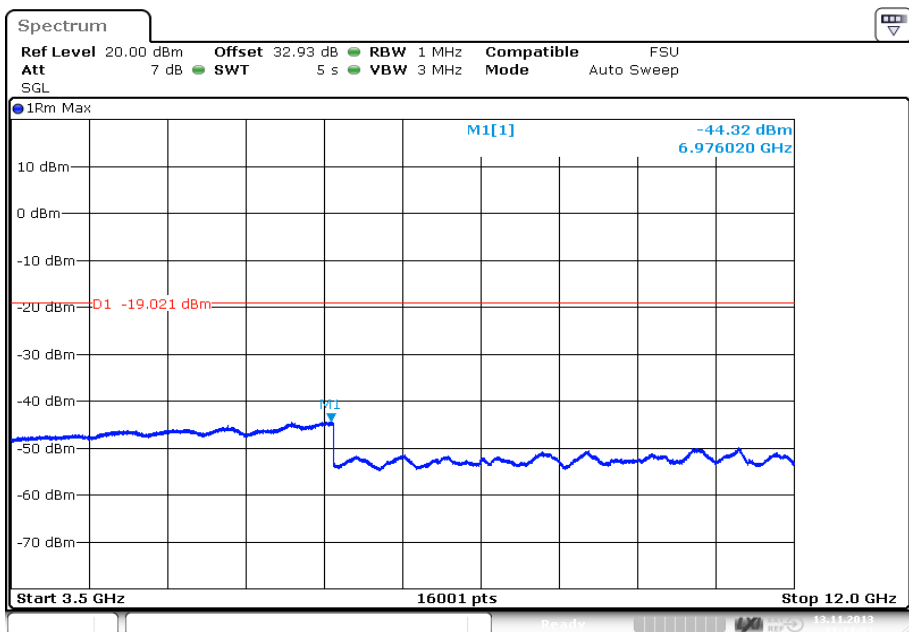

Channel Position M - Carrier Bandwidth 5.0 MHz - Band 3 - Range 12000 to 20000 MHz

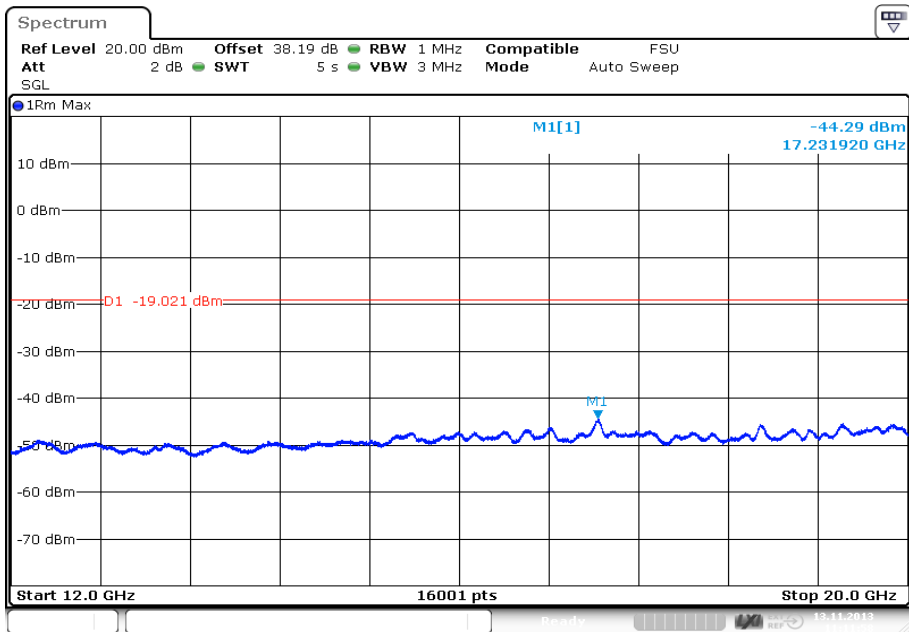

Date: 13.NOV.2013 11:11:59

Channel Position M - Carrier Bandwidth 20.0 MHz - Band 1 - Range 0.009 to 3500 MHz

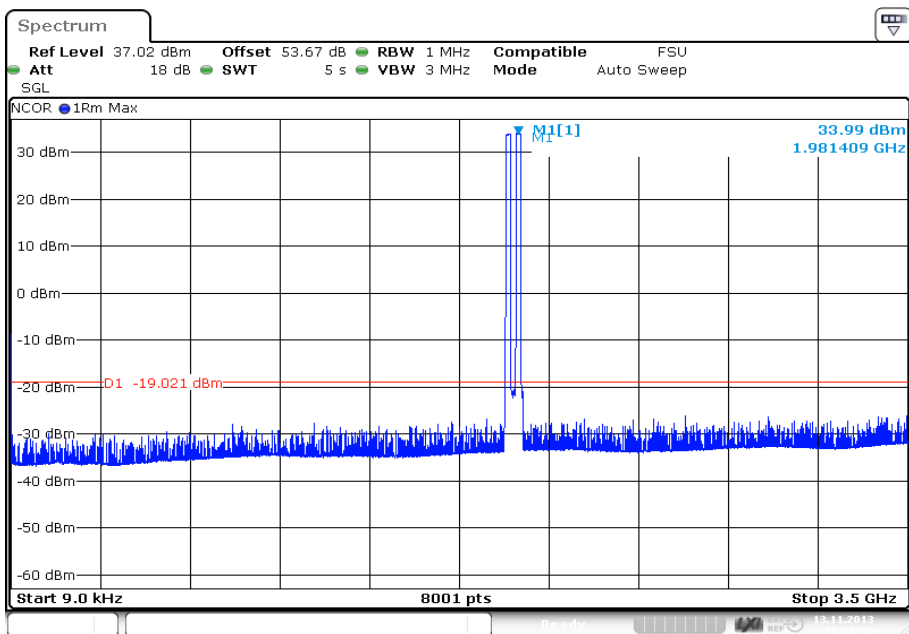

Date: 13.NOV.2013 16:58:20

Channel Position M - Carrier Bandwidth 20.0 MHz - 1930 MHz - 1990 MHz - Range 3500 to 12000 MHz

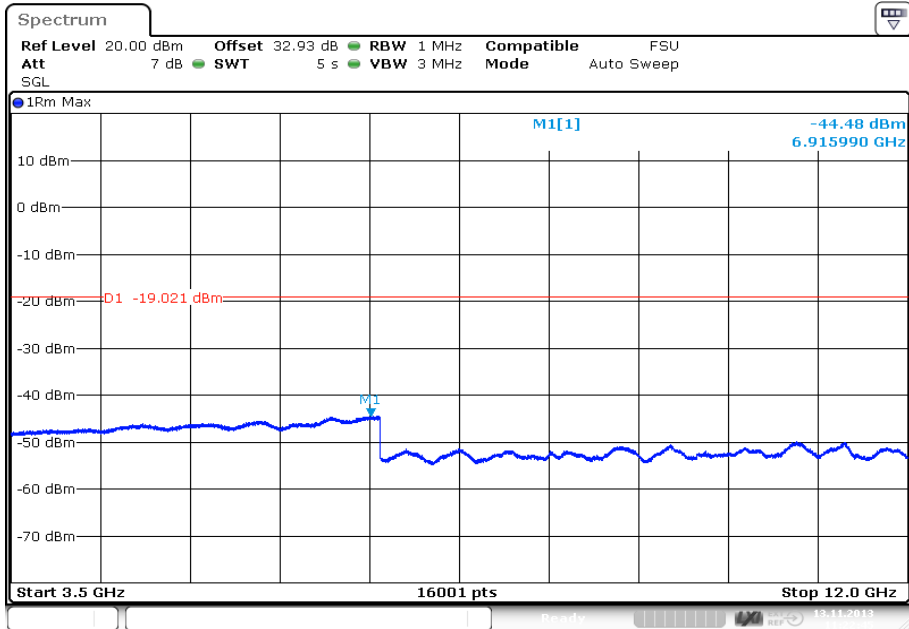

Date: 13.NOV.2013 11:22:45

Channel Position M - Carrier Bandwidth 20.0 MHz - Band 3 - Range 12000 to 20000 MHz

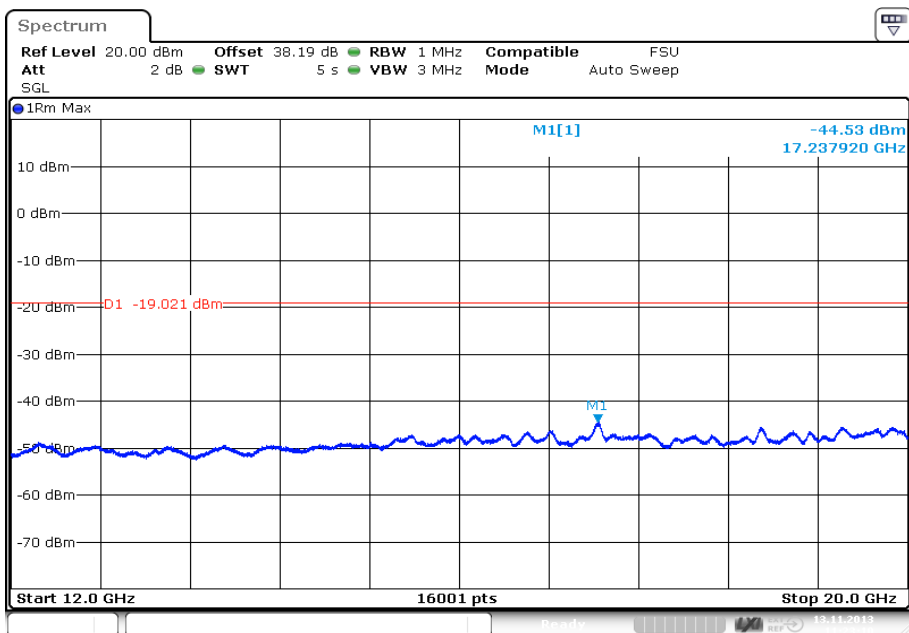

Date: 13.NOV.2013 11:23:10

Configuration LTE-MC2 (See Table 1 for carrier frequency)

Maximum Output Power 40 dBm per carrier, Test Model 1.1

Channel Position M - Carrier Bandwidth 5.0 MHz - Band 1 - Range 0.009 to 3500 MHz

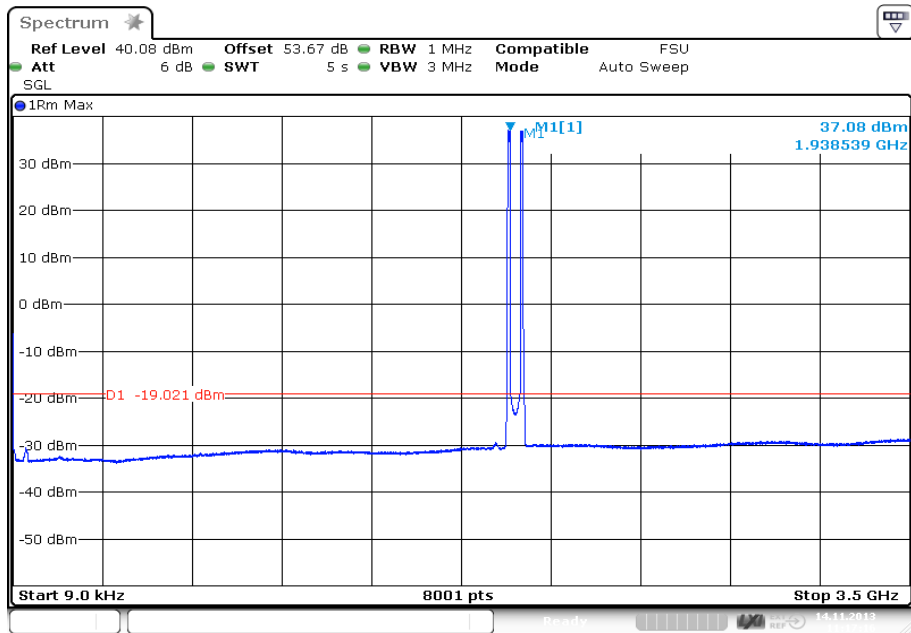

Date: 14.NOV.2013 11:17:17

Channel Position M - Carrier Bandwidth 5.0 MHz - 1930 MHz - 1990 MHz - Range 3500 to 12000 MHz

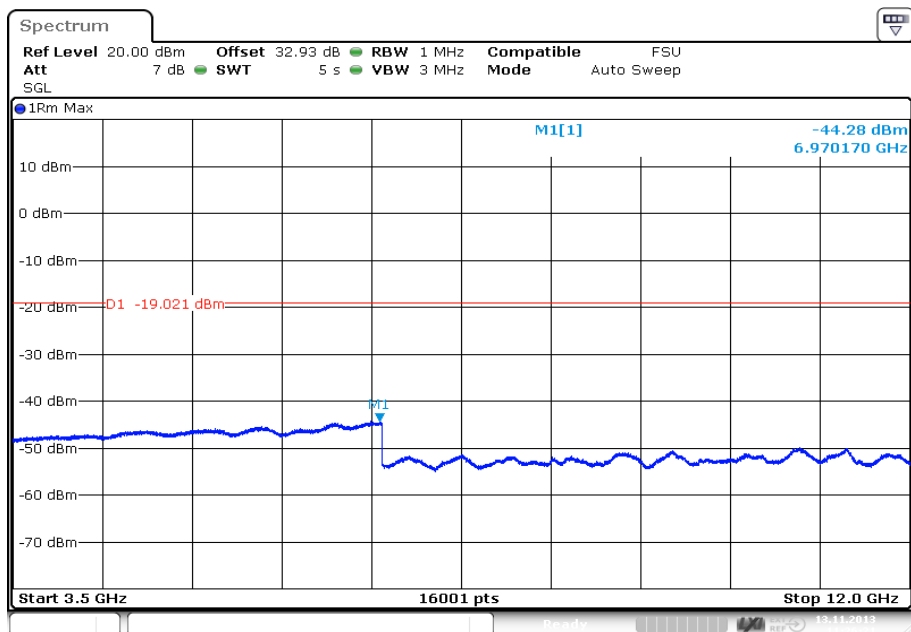

Date: 13.NOV.2013 11:26:21

Channel Position M - Carrier Bandwidth 5.0 MHz - Band 3 - Range 12000 to 20000 MHz

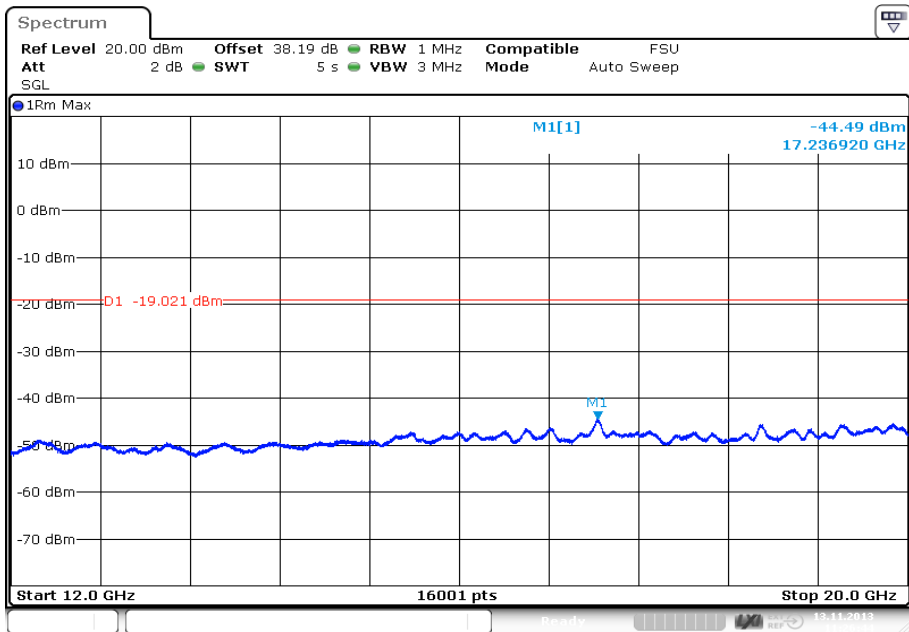

Date: 13.NOV.2013 11:26:44

Channel Position M - Carrier Bandwidth 10.0 MHz - Band 1 - Range 0.009 to 3500 MHz

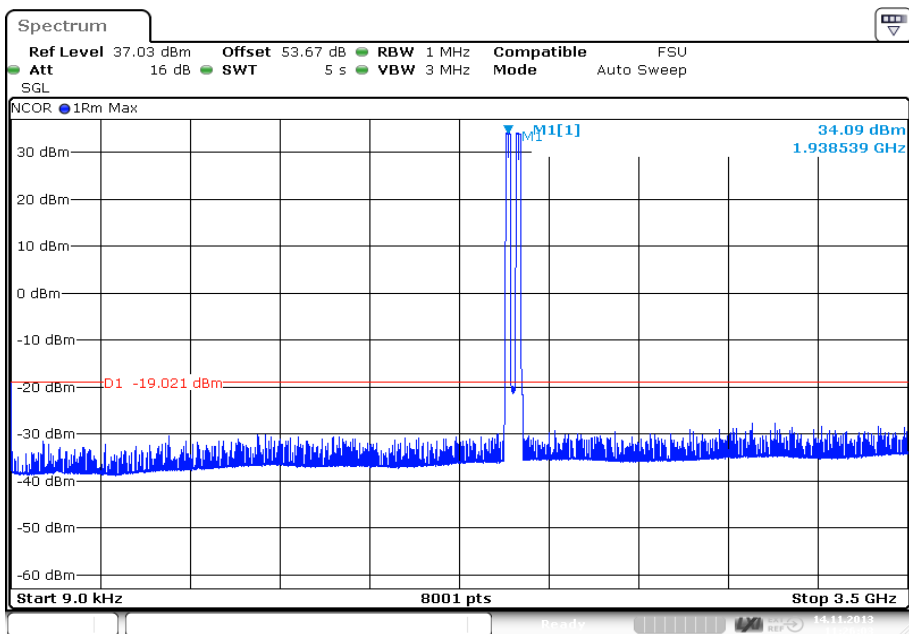

Date: 14.NOV.2013 11:26:04

Channel Position M - Carrier Bandwidth 10.0 MHz - 1930 MHz - 1990 MHz - Range 3500 to 12000 MHz

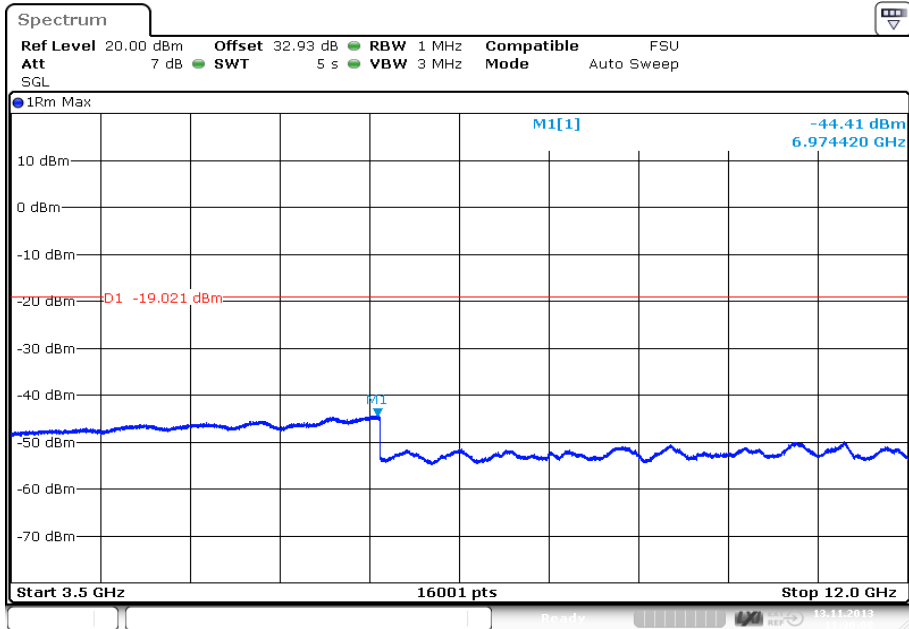

Date: 13.NOV.2013 11:30:09

Channel Position M - Carrier Bandwidth 10.0 MHz - Band 3 - Range 12000 to 20000 MHz

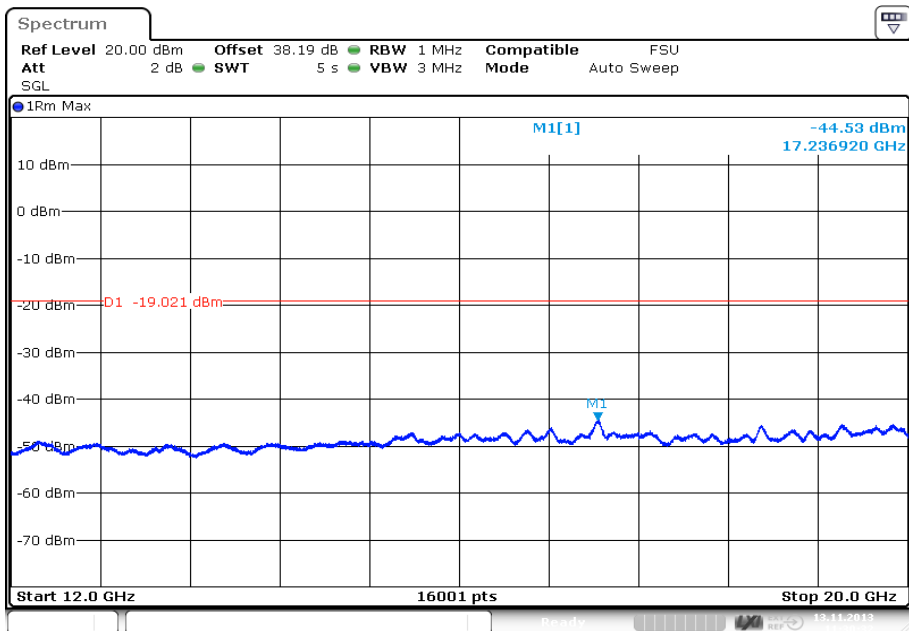

Date: 13.NOV.2013 11:30:33

Configuration CDMA-SC (See Table 1 for carrier frequency)

Maximum Output Power 46 dBm per carrier

Channel Position B - Modulation QPSK - Band 1 - Range 0.009 to 3500 MHz

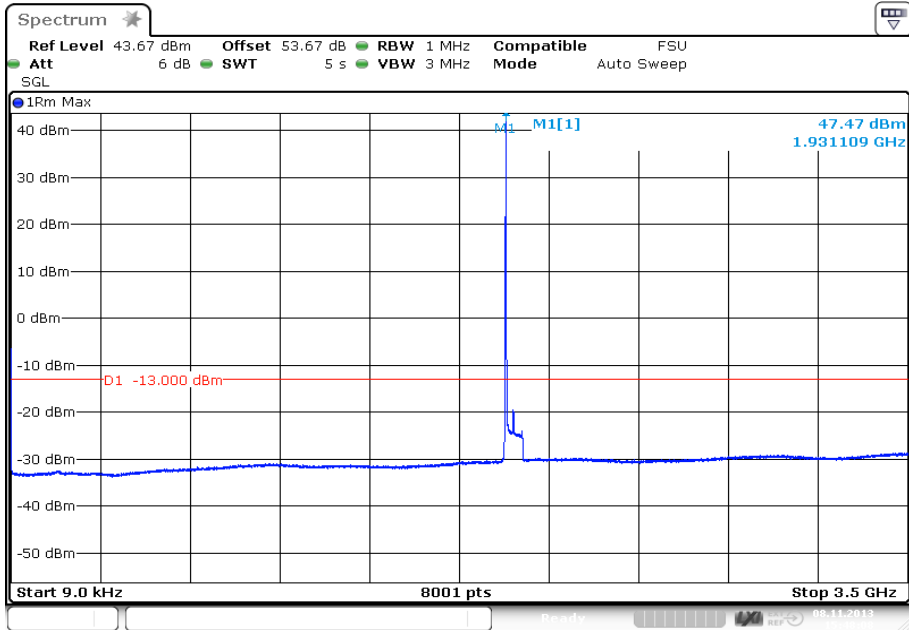

Channel Position B - Modulation QPSK - 1930 MHz - 1990 MHz - Range 3500 to 12000 MHz

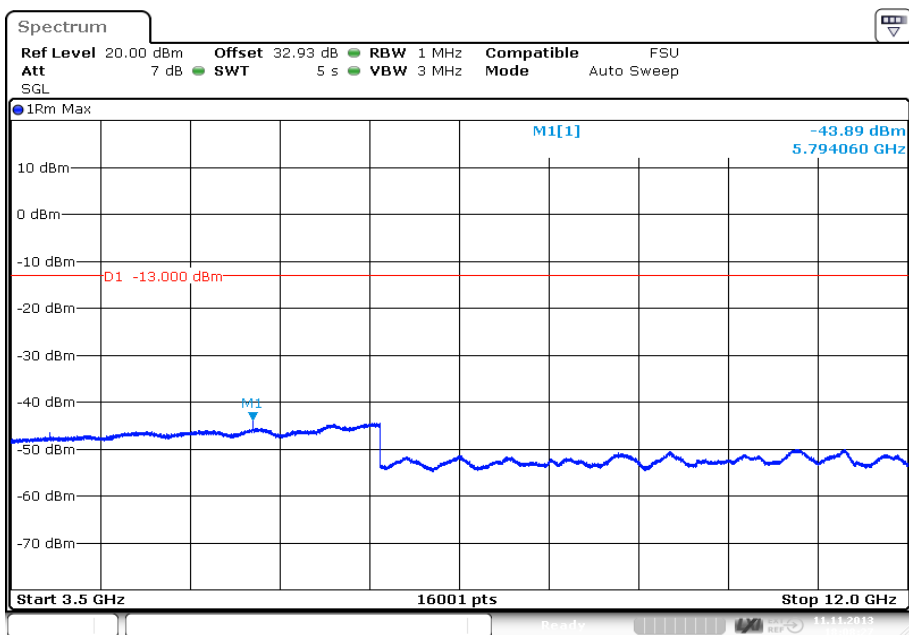

Channel Position B - Modulation QPSK - Band 3 - Range 12000 to 20000 MHz

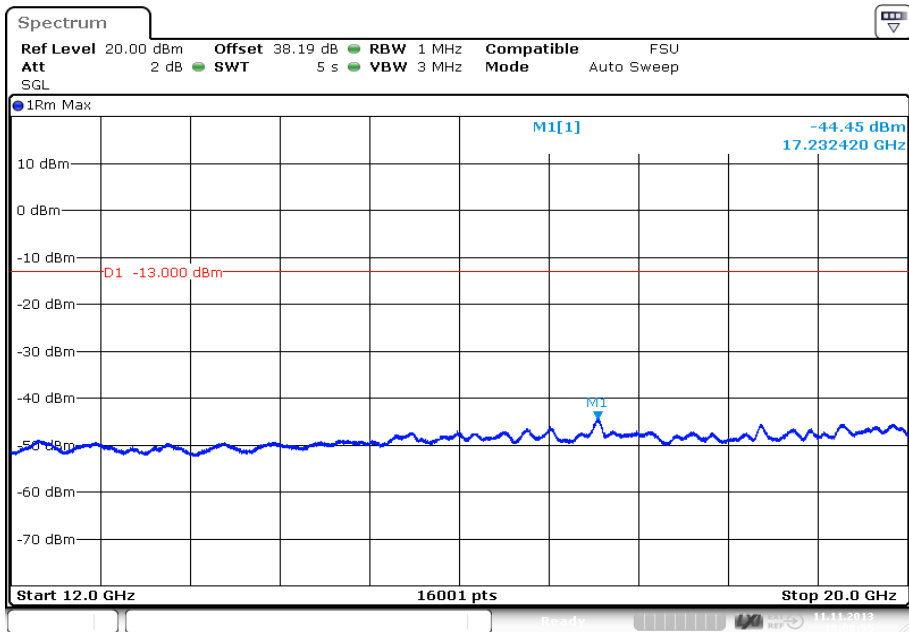

Date: 11.NOV.2013 18:08:56

Channel Position M - Modulation QPSK - Band 1 - Range 0.009 to 3500 MHz

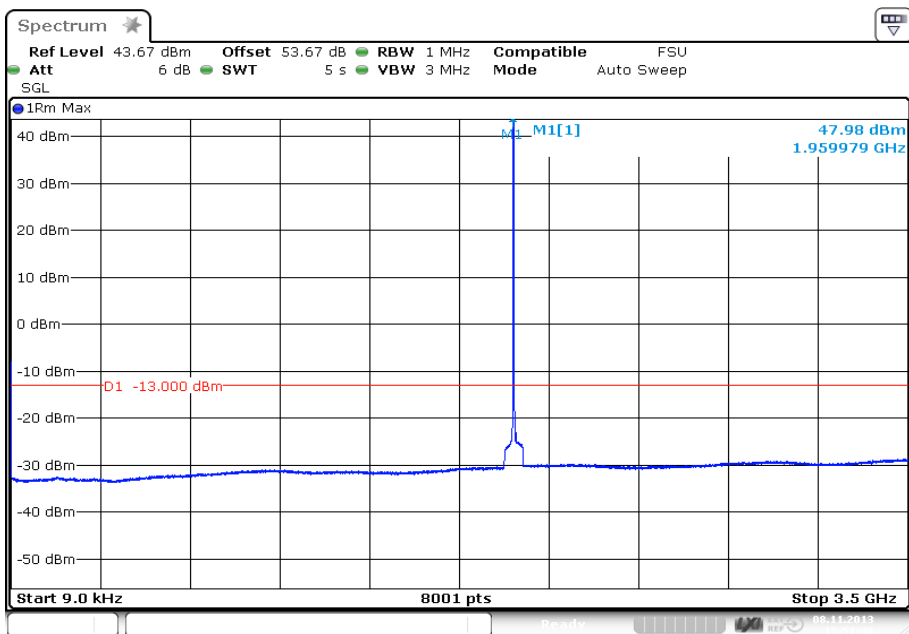

Date: 8.NOV.2013 15:51:48

Channel Position M - Modulation QPSK - 1930 MHz - 1990 MHz - Range 3500 to 12000 MHz

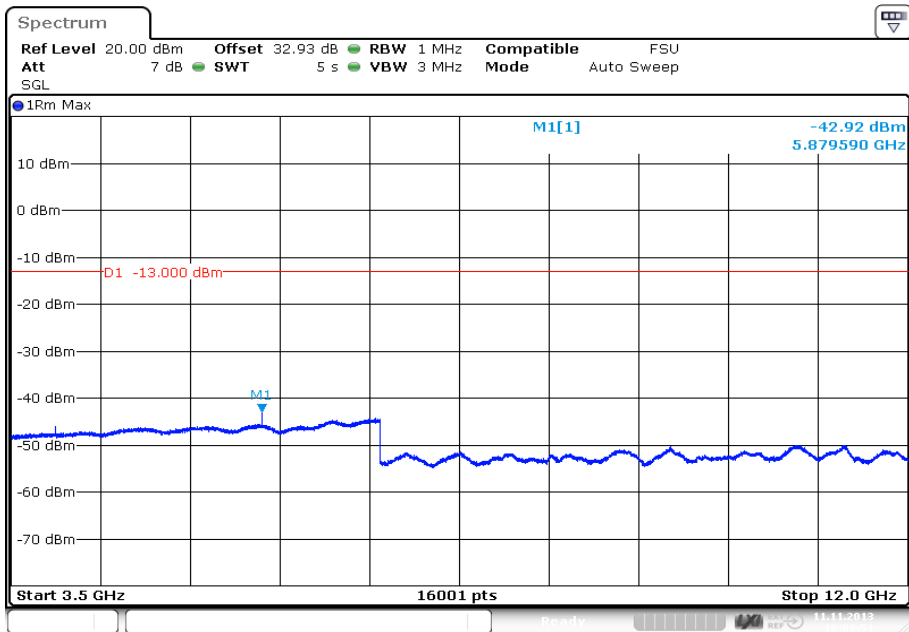

Channel Position M - Modulation QPSK - Band 3 - Range 12000 to 20000 MHz

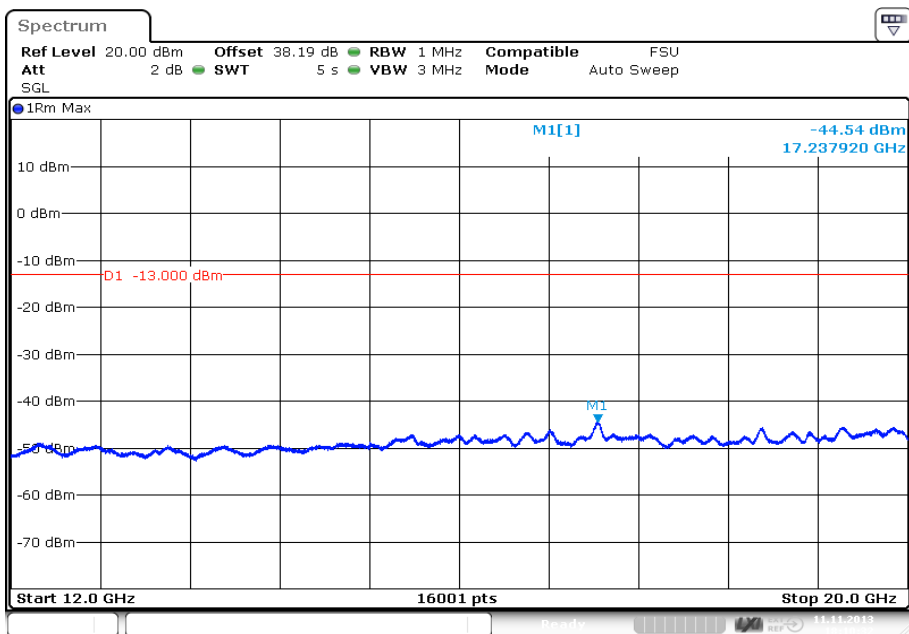

Channel Position T - Modulation QPSK - Band 1 - Range 0.009 to 3500 MHz

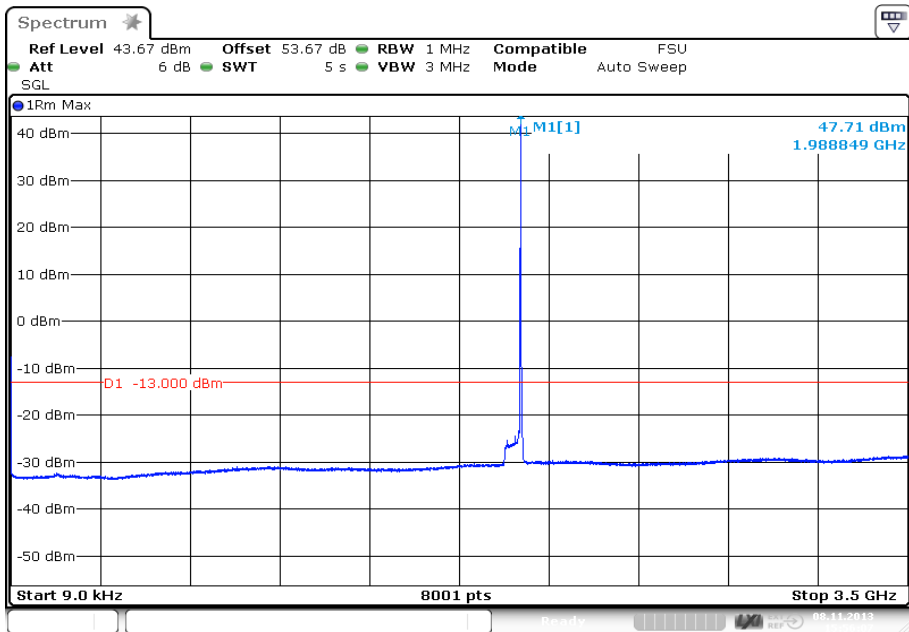

Channel Position T - Modulation QPSK - 1930 MHz - 1990 MHz - Range 3500 to 12000 MHz

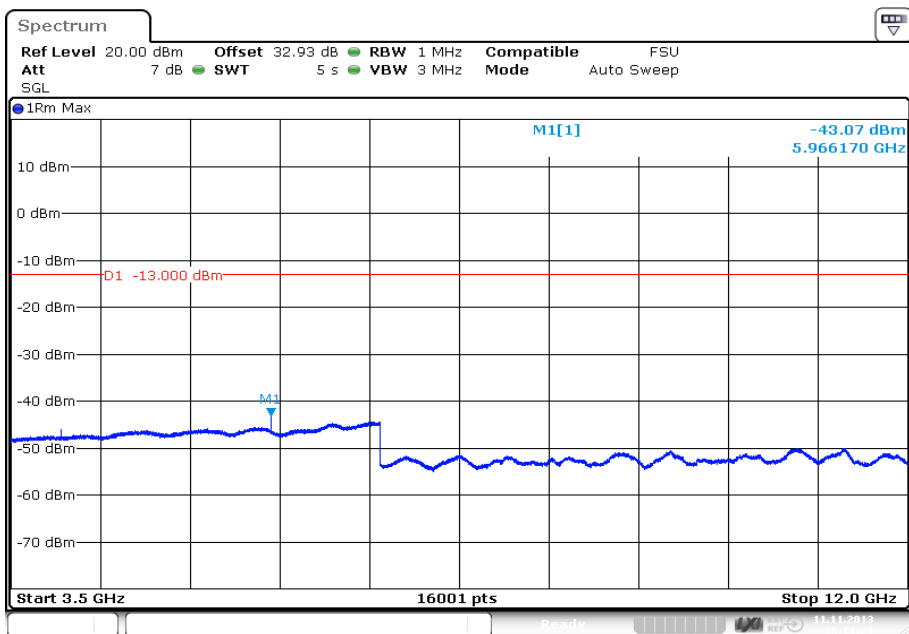

Channel Position T - Modulation QPSK - Band 3 - Range 12000 to 20000 MHz

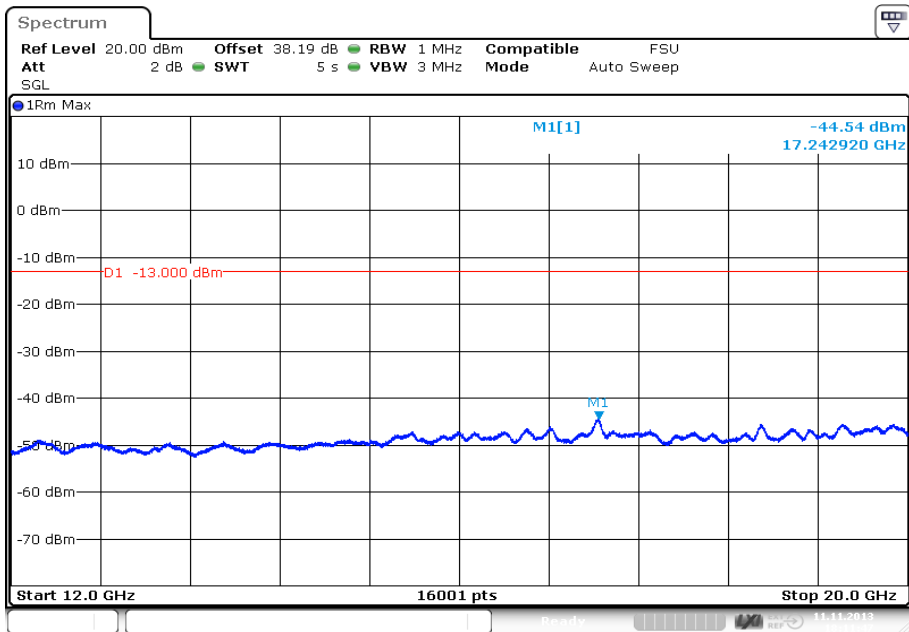

Configuration CDMA-MC1 (See Table 2 for carrier frequency)

Maximum Output Power 43 dBm per carrier

Channel Position M - Modulation QPSK - Band 1 - Range 0.009 to 3500 MHz

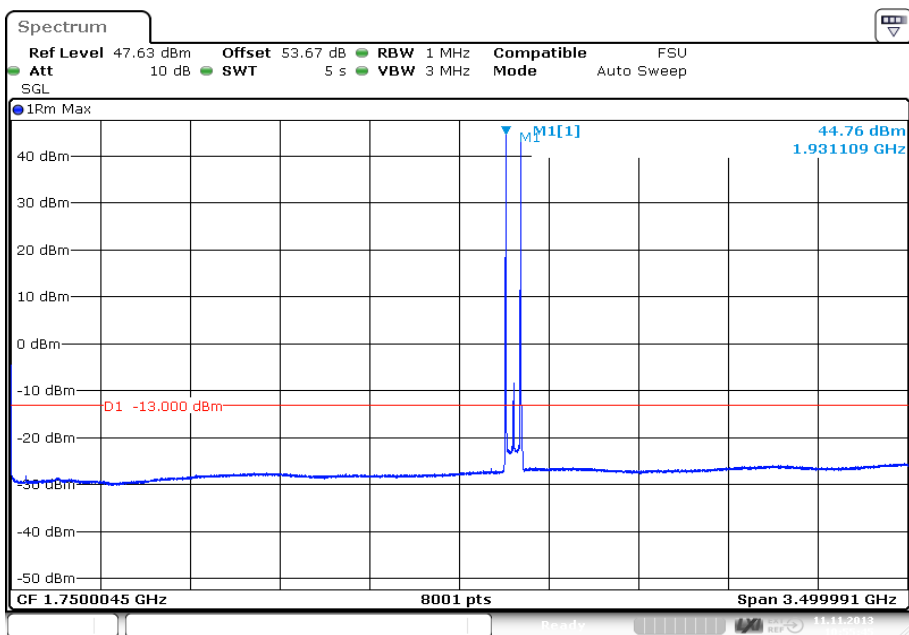

Channel Position M - Modulation QPSK - 1930 MHz - 1990 MHz - Range 3500 to 12000 MHz

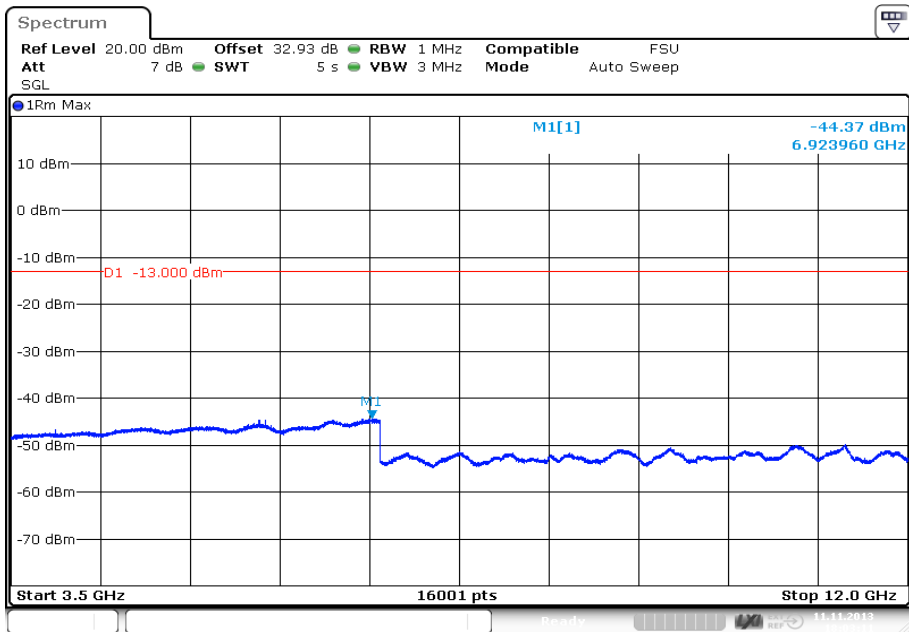

Date: 11.NOV.2013 18:03:11

Channel Position M - Modulation QPSK - Band 3 - Range 12000 to 20000 MHz

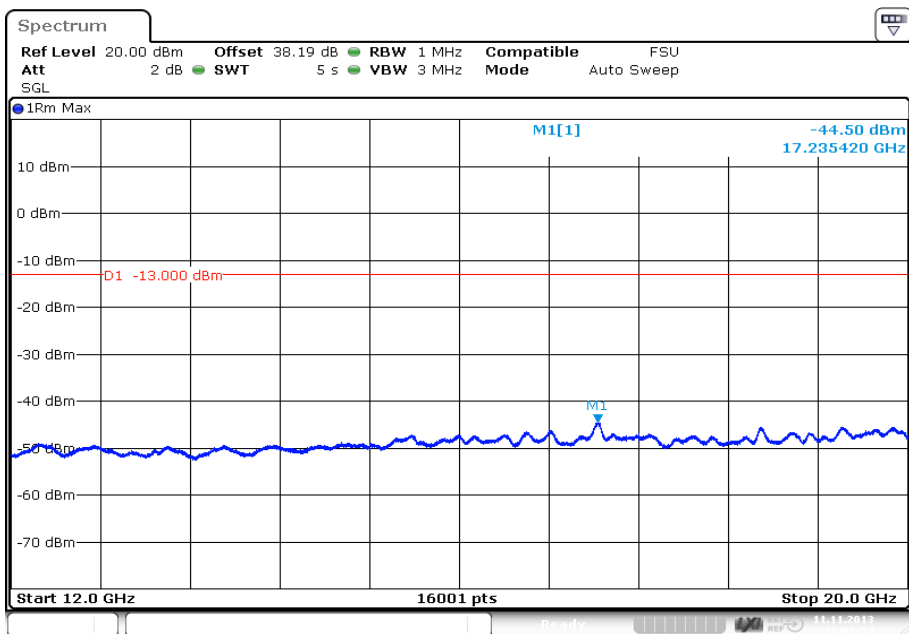

Date: 11.NOV.2013 18:03:54

Configuration CDMA-MC2

Maximum Output Power 40 dBm per carrier

Channel Position M - Modulation QPSK - Band 1 - Range 0.009 to 3500 MHz

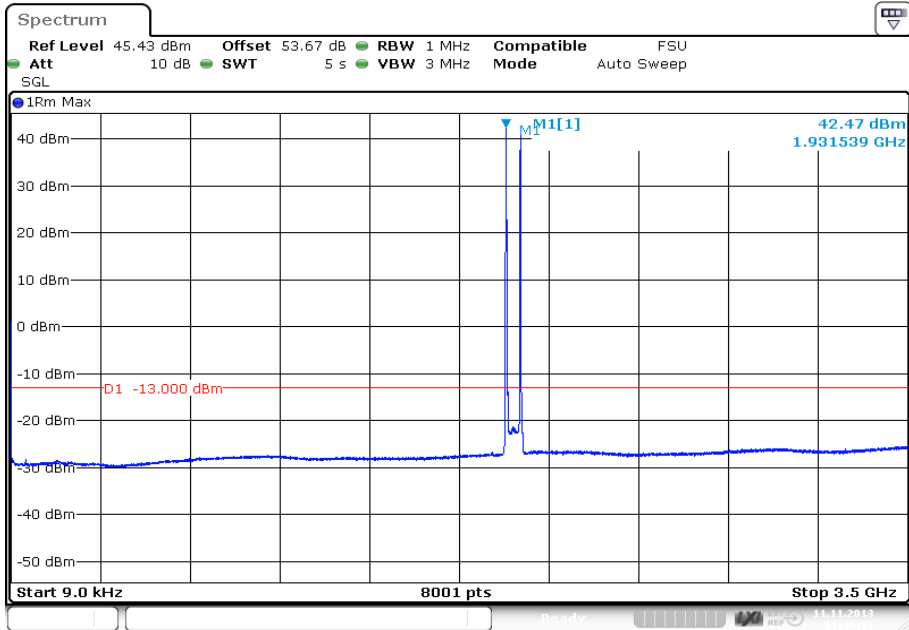

Date: 11.NOV.2013 11:40:17

Channel Position M - Modulation QPSK - 1930 MHz - 1990 MHz - Range 3500 to 12000 MHz

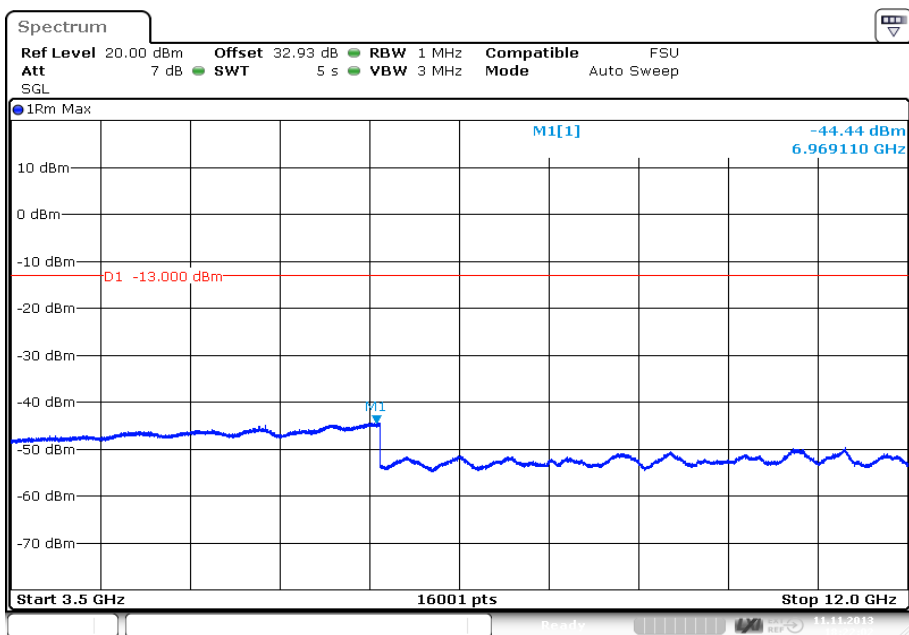

Date: 11.NOV.2013 18:22:03

Channel Position M - Modulation QPSK - Band 3 - Range 12000 to 20000 MHz

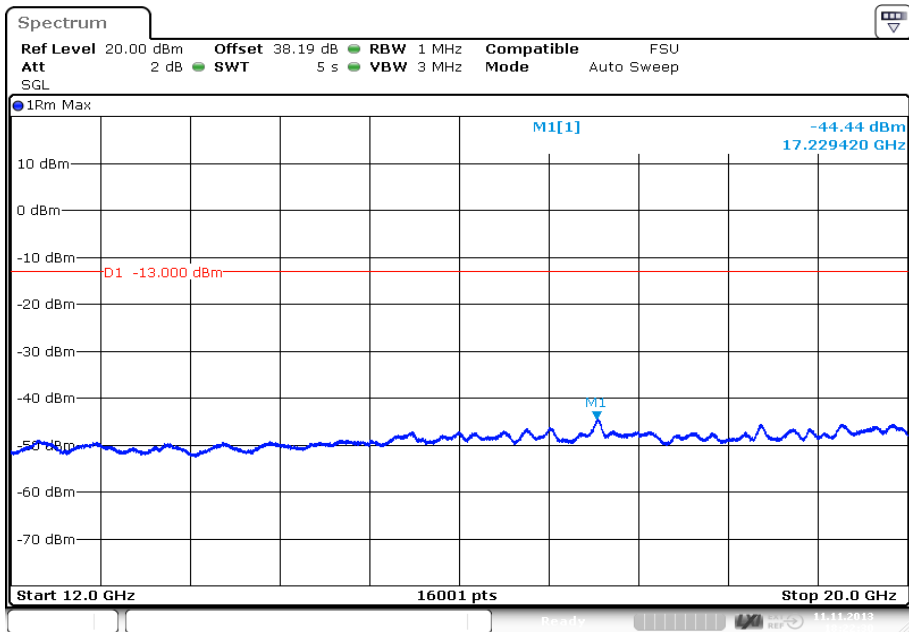

Configuration LTE+CDMA-MC1 (See Table 1 for carrier frequency)

Maximum Output Power 43 dBm per carrier

Channel Position MRFBW - CDMA Modulation QPSK / LTE Test Model 1.1/ Bandwidth 5.0 MHz - Band 1 - Range 0.009 to 3500 MHz

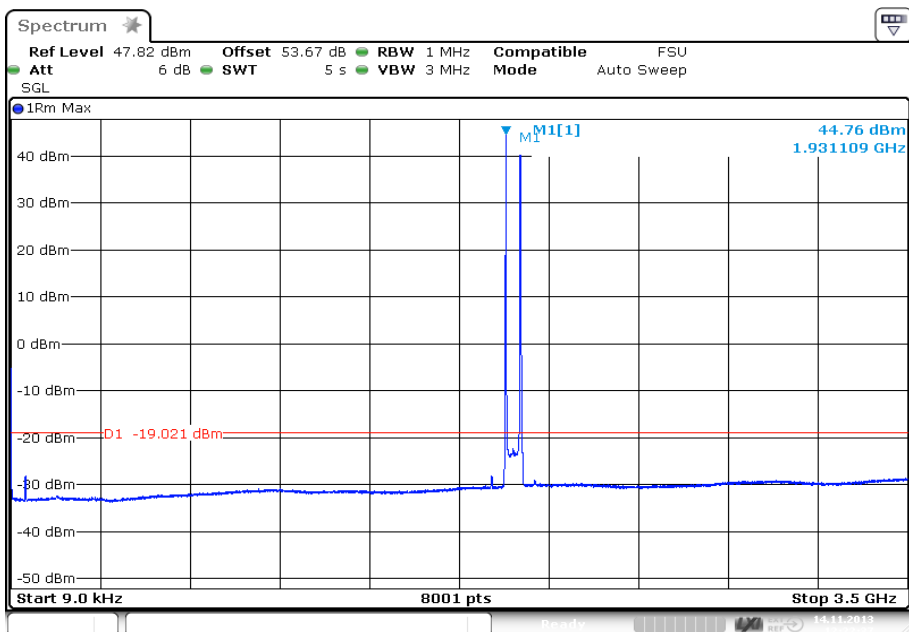

Channel Position MRFBW - CDMA Modulation QPSK / LTE Test Model 1.1 / Bandwidth 5.0MHz
- 1930 MHz - 1990 MHz - Range 3500 to 12000 MHz

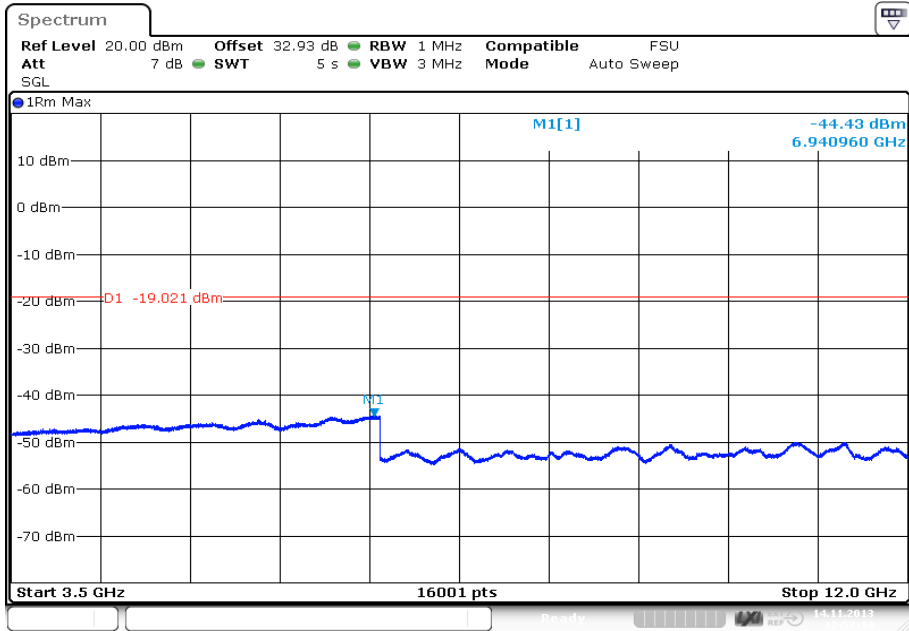

Channel Position MRFBW - CDMA Modulation QPSK / LTE Test Model 1.1 / Bandwidth 5.0 MHz
- Band 3 - Range 12000 to 20000 MHz

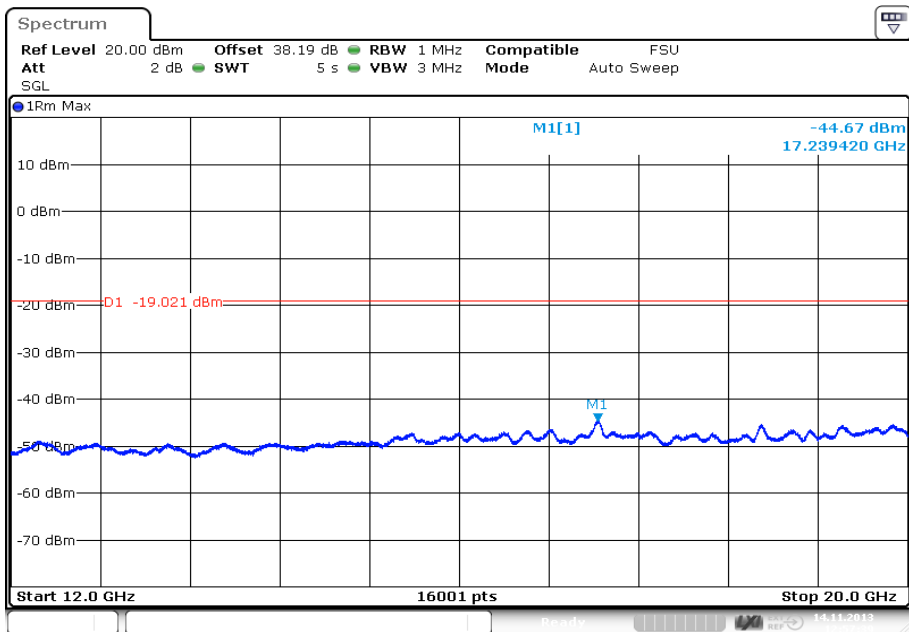

Limit	Level
Single Port	-13 dBm
2 Port MIMO	-16 dBm
4 Port MIMO	-19 dBm

2.5 FREQUENCY STABILITY

2.5.1 Specification Reference

FCC CFR 47 Part 2, Clause 2.1055
FCC CFR 47 Part 24, Clause 24.235
Industry Canada RSS-133, Clause 6.3

2.5.2 Date of Test and Modification State

18 November 2013 - Modification State 1

2.5.3 Test Equipment Used

The major items of test equipment used for the above tests are identified in Section 3.1.

2.5.4 Environmental Conditions

Ambient Temperature	22.9°C
Relative Humidity	36.5%

2.5.5 Test Method

Frequency Error – Temperature Variation

The EUT was setup in a Climatic Chamber and connected to a Vector Signal Analyser via attenuators. The temperature was varied over the range -30°C to +50°C in 10°C steps. At each temperature interval, the EUT was left to stabilise. After this period of time, the mean Frequency Error was measured and recorded on the Middle channel.

For LTE, testing was performed using a 10MHz channel bandwidth with QPSK modulation and all Resource Blocks active.

For CDMA, 1xEV-DO with QPSK modulation was tested.

At 20°C, the voltage was varied between 85% and 115% of the nominal declared voltage. At each extreme voltage, the mean Frequency Error was measured and recorded.

2.5.6 Test Results

Configuration LTE-SC (See Table 1 for carrier frequency)

Maximum Output Power 46 dBm per carrier, Test Model 1.1, 10 MHz Channel Bandwidth

Temperature	Frequency Stability (Hz)
	Channel Position M
-30°C	+2.75
-20°C	-2.48
-10°C	+3.00
0°C	-2.26
+10°C	-3.30
+20°C	-2.54
+30°C	-2.47
+40°C	+2.07
+50°C	+1.86

Configuration CDMA-SC (See Table 1 for carrier frequency)

Maximum Output Power 46 dBm per carrier, QPSK Modulation

Temperature	Frequency Stability (Hz)
	Channel Position M
-30°C	-3.72
-20°C	-3.53
-10°C	+3.30
0°C	-2.93
+10°C	-3.68
+20°C	+2.93
+30°C	+2.90
+40°C	-2.71
+50°C	-2.86

Configuration LTE-SC (See Table 1 for carrier frequency)

Maximum Output Power 46 dBm per carrier, Test Model 1.1, 10 MHz Channel Bandwidth

Voltage	Frequency Stability (Hz)
	Channel Position M
-40.8 V	+2.19
-48.0 V	-2.54
-55.2 V	-2.78

Configuration CDMA-SC (See Table 1 for carrier frequency)

Maximum Output Power 46 dBm per carrier, QPSK Modulation

Voltage	Frequency Stability (Hz)
-40.8 V	-2.75
-48.0 V	+2.93
-55.2 V	-3.61

Limit	± 1.0 ppm or ± 1.96 kHz
-------	---------------------------------



Product Service

SECTION 3

TEST EQUIPMENT USED

3.1 TEST EQUIPMENT USED

List of absolute measuring and other principal items of test equipment.

Instrument	Manufacturer	Type No.	TE No.	Calibration Period (months)	Calibration Due
Network Analyzer	Hewlett Packard	8722D	US39150711	12	28-Oct-2014
Spectrum Analyzer	Rohde & Schwarz	FSV30;G	101259	12	10-Oct-2014
2 Channel Power Meter	Agilent Technologies	N1912A	MY45101238	24	28-Mar-2015
2 Channel Power Meter	Agilent Technologies	N1912A	MY45101436	24	10-Oct-2015
Power Sensor	Agilent Technologies	N1921A	MY45241229	12	10-Oct-2014
Power Sensor	Agilent Technologies	N1921A	MY45200270	12	10-Oct-2014
Power Sensor	Agilent Technologies	N1921A	MY45200253	12	10-Oct-2014
Power Sensor	Agilent Technologies	N1921A	MY45240248	12	10-Oct-2014
DC Power Supply	Xantrex	XKW 60-50	E00109863	-	OP MON
Thermocouple Thermometer	Fluke	51	TE 3173	12	28-Aug-2014
Hygrometer	Rotronic	A1	643-29	12	12-Sep-2014
Multimeter	Iso-tech	IDM101	TE 2424	12	12-Sep-2014
3.2 GHz High Pass Filter	Wainwright	WHKX3.2/18G-12SS	5	-	OP MON
Temperature Chamber	Burnsco	RTC-37P-3-3	07-07	-	OP MON
Attenuator 1	Weinschel	WA66-30-34	A250	-	OP MON
Attenuator 2	Narda	SA18N50W-20	N/S	-	OP MON
Attenuator 3	Weinschel	WA66-30-34	A249	-	OP MON
Attenuator 4	Narda	765A-10	101913	-	OP MON
Attenuator 5	Weinschel	48-30-43	BJ2518	-	OP MON
Attenuator 6	Narda	765A-10	101803	-	OP MON
Attenuator 7	Weinschel	48-30-43	BJ6048	-	OP MON
Attenuator 8	Narda	765A-10	101794	-	OP MON

N/A – Not Applicable

OP MON – Output Monitored with Calibrated Equipment

3.2 MEASUREMENT UNCERTAINTY

For a 95% confidence level, the measurement uncertainties for defined systems are:-

Test Discipline	Frequency / Parameter	MU
Conducted Maximum Peak Output Power	30 MHz to 20 GHz Amplitude	± 0.5 dB
Conducted Emissions	30 MHz to 20 GHz Amplitude	± 3.5 dB
Frequency Stability	30 MHz to 2 GHz Amplitude	± 0.03 Hz
Occupied Bandwidth	Up to 20 MHz Bandwidth	± 290 kHz
Band Edge	30 MHz to 20 GHz Amplitude	± 3.5 dB



Product Service

SECTION 5

DISCLAIMERS AND COPYRIGHT



Product Service

4.1 DISCLAIMERS AND COPYRIGHT

This report relates only to the actual item/items tested.

© 2013 TÜV SÜD Product Service



Product Service

ANNEX A

MODULE LIST



Product Service

Module List			
Product	Product No	R-State	Serial No
CT10	LPC 102 487/1	R1C	T01F225034
RRUS 31 B25	KRC 118 159/1	R1C	D74DA00020
Software Version:	R1C06/R1E	Revision:	R1C