

---

## Low-Power Long Range LoRa® Technology Transceiver Module

---

### General Features

- On-board LoRaWAN™ protocol stack
- ASCII command interface over UART
- Compact form factor: 17.8 x 26.7 x 3.34 mm
- Castellated SMT pads for easy and reliable PCB mounting
- Environmentally friendly, RoHS compliant
- Compliance:
  - Modular Certified for the United States (FCC) and Canada (IC)
  - Australia and New Zealand
- Device Firmware Upgrade (DFU) over UART, see “RN2903 LoRa® Technology Module Command Reference User’s Guide” (DS40001811)

### Operational

- Single operating voltage: 2.1V to 3.6V (3.3V typical)
- Temperature range: -40°C to +85°C
- Low-power consumption
- Programmable RF Communication Bit Rate up to 300 kbps with FSK modulation, 12500 bps with LoRa® Technology modulation
- Integrated MCU, Crystal, EU-64 Node Identity Serial EEPROM, Radio Transceiver with Analog Front End, Matching Circuitry
- 14 GPIOs for control and status

### RF/Analog Features

- Low-Power Long Range Transceiver operating in the 915 MHz frequency band
- High Receiver Sensitivity: down to -146 dBm
- TX Power: adjustable up to +18.5 dBm high efficiency PA
- FSK, GFSK, and LoRa Technology modulation
- IIP3 = -11 dBm
- Up to 15 km coverage at suburban and up to 5 km coverage at urban area

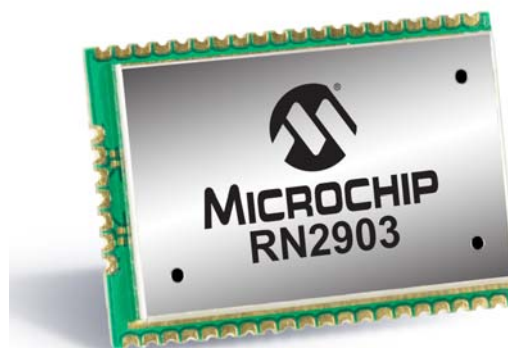

### Description

Microchip's RN2903 Low-Power Long Range LoRa Technology Transceiver module provides an easy to use, low-power solution for long range wireless data transmission. The advanced command interface offers rapid time to market.

The RN2903 module complies with the LoRaWAN Class A protocol specifications. It integrates RF, a baseband controller, command Application Programming Interface (API) processor, making it a complete long range solution.

The RN2903 module is suitable for simple long range sensor applications with external host MCU.

### Applications

- Automated Meter Reading
- Home and Building Automation
- Wireless Alarm and Security Systems
- Industrial Monitoring and Control
- Machine to Machine (M2M)
- Internet of Things (IoT)

## Table of Contents

1.0 Device Overview .....	3
2.0 General Specifications .....	6
3.0 Typical Hardware Connections.....	8
4.0 Physical Dimensions .....	9
5.0 Application Information.....	10
6.0 Regulatory Approval .....	14
Appendix A: Revision History .....	19
The Microchip Web Site .....	21
Customer Change Notification Service .....	21
Customer Support.....	21
Product Identification System.....	23

### TO OUR VALUED CUSTOMERS

It is our intention to provide our valued customers with the best documentation possible to ensure successful use of your Microchip products. To this end, we will continue to improve our publications to better suit your needs. Our publications will be refined and enhanced as new volumes and updates are introduced.

If you have any questions or comments regarding this publication, please contact the Marketing Communications Department via E-mail at [docerrors@microchip.com](mailto:docerrors@microchip.com). We welcome your feedback.

#### Most Current Data Sheet

To obtain the most up-to-date version of this data sheet, please register at our Worldwide Web site at:

<http://www.microchip.com>

You can determine the version of a data sheet by examining its literature number found on the bottom outside corner of any page. The last character of the literature number is the version number, (e.g., DS30000000A is version A of document DS30000000).

#### Errata

An errata sheet, describing minor operational differences from the data sheet and recommended workarounds, may exist for current devices. As device/documentation issues become known to us, we will publish an errata sheet. The errata will specify the revision of silicon and revision of document to which it applies.

To determine if an errata sheet exists for a particular device, please check with one of the following:

- Microchip's Worldwide Web site; <http://www.microchip.com>
- Your local Microchip sales office (see last page)

When contacting a sales office, please specify which device, revision of silicon and data sheet (include literature number) you are using.

#### Customer Notification System

Register on our web site at [www.microchip.com](http://www.microchip.com) to receive the most current information on all of our products.

## 1.0 DEVICE OVERVIEW

The RN2903 transceiver module features LoRa Technology RF modulation, which provides long range spread spectrum communication with high interference immunity.

Using LoRa Technology modulation technique, RN2903 can achieve a receiver sensitivity of -146 dBm. The high sensitivity combined with the integrated +18.5 dBm output power amplifier yields industry leading link budget, which makes it optimal for applications requiring extended range and robustness.

LoRa Technology modulation also provides significant advantages in both blocking and selectivity compared to the conventional modulation techniques, solving the traditional design compromise between extended range, interference immunity, and low-power consumption.

The RN2903 module delivers exceptional phase noise, selectivity, receiver linearity, and IIP3 for significantly lower power consumption. The level of conductive harmonics is below -70 dBm. [Figure 1-1](#), [Figure 1-2](#), and [Figure 1-3](#) show the top view, the pinout, and the block diagram of the module.

**FIGURE 1-1: RN2903 TOP VIEW**

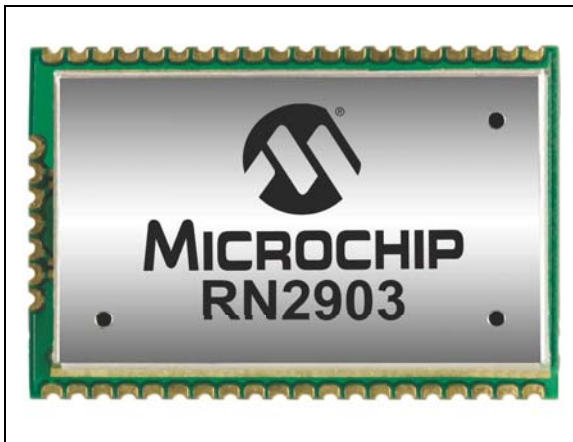

**FIGURE 1-2: RN2903 PIN DIAGRAM**

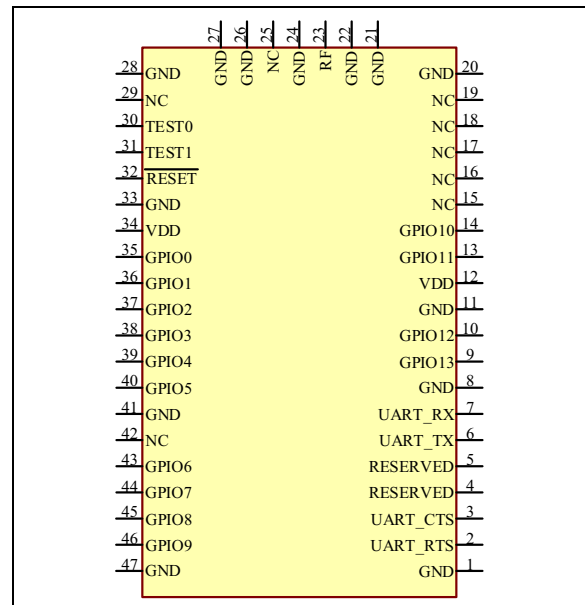

**FIGURE 1-3: RN2903 BLOCK DIAGRAM**

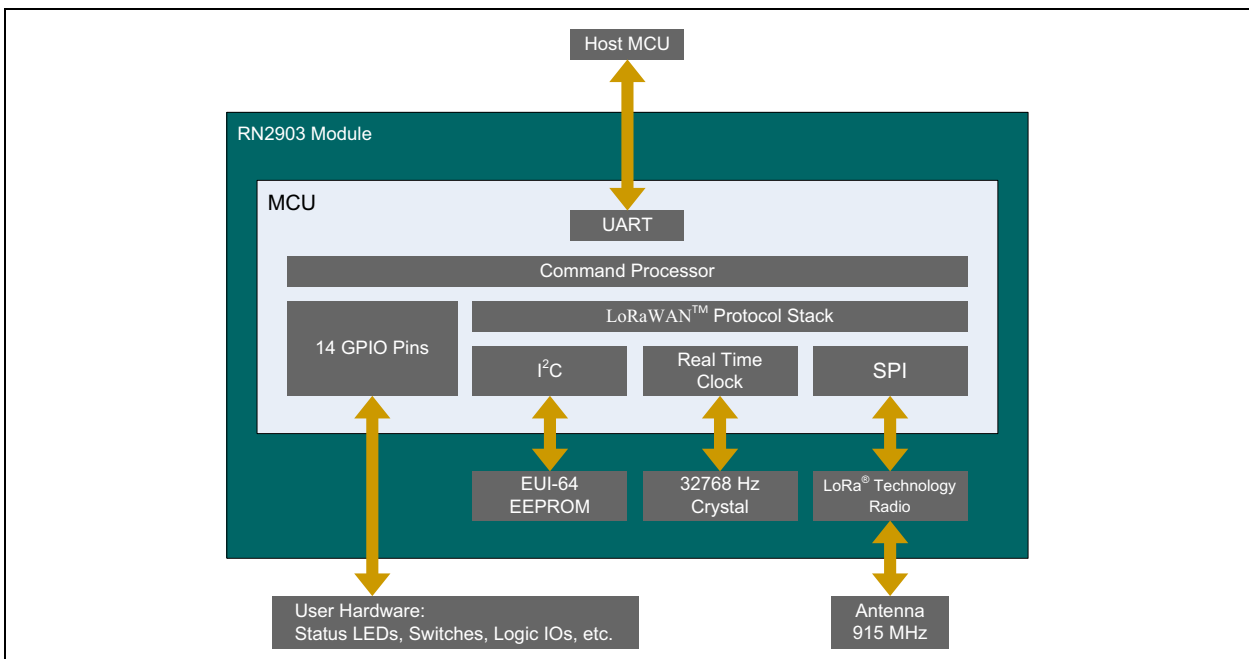

# RN2903

Table 1-1 describes the pins of the module.

**TABLE 1-1: PIN DESCRIPTION**

Pin	Name	Type	Description
1	GND	Power	Ground supply terminal
2	UART_RTS	Output	Communication UART RTS signal <sup>(1)</sup>
3	UART_CTS	Input	Communication UART CTS signal <sup>(1)</sup>
4	RESERVED	—	Do not connect
5	RESERVED	—	Do not connect
6	UART_TX	Output	Communication UART Transmit (TX)
7	UART_RX	Input	Communication UART Receive (RX)
8	GND	Power	Ground supply terminal
9	GPIO13	Input/Output	General purpose I/O pin
10	GPIO12	Input/Output	General purpose I/O pin
11	GND	Power	Ground supply terminal
12	VDD	Power	Positive supply terminal
13	GPIO11	Input/Output	General purpose I/O pin
14	GPIO10	Input/Output	General purpose I/O pin
15	NC	—	Not connected
16	NC	—	Not connected
17	NC	—	Not connected
18	NC	—	Not connected
19	NC	—	Not connected
20	GND	Power	Ground supply terminal
21	GND	Power	Ground supply terminal
22	GND	Power	Ground supply terminal
23	RF	RF analog	RF signal pin
24	GND	Power	Ground supply terminal
25	NC	—	Not connected
26	GND	Power	Ground supply terminal
27	GND	Power	Ground supply terminal
28	GND	Power	Ground supply terminal
29	NC	—	Not connected
30	TEST0	—	Do not connect
31	TEST1	—	Do not connect
32	RESET	Input	Active-low device Reset input
33	GND	Power	Ground supply terminal
34	VDD	Power	Positive supply terminal
35	GPIO0	Input/Output	General purpose I/O pin
36	GPIO1	Input/Output	General purpose I/O pin
37	GPIO2	Input/Output	General purpose I/O pin
38	GPIO3	Input/Output	General purpose I/O pin
39	GPIO4	Input/Output	General purpose I/O pin
40	GPIO5	Input/Output	General purpose I/O pin
41	GND	Power	Ground supply terminal
42	NC	—	Not connected
43	GPIO6	Input/Output	General purpose I/O pin

**TABLE 1-1: PIN DESCRIPTION (CONTINUED)**

Pin	Name	Type	Description
44	GPIO7	Input/Output	General purpose I/O pin
45	GPIO8	Input/Output	General purpose I/O pin
46	GPIO9	Input/Output	General purpose I/O pin
47	GND	Power	Ground supply terminal

**Note 1:** Optional handshake lines are supported in future firmware releases.

# RN2903

## 2.0 GENERAL SPECIFICATIONS

Table 2-1 provides the general specifications for the module. Table 2-2, Table 2-3, and Table 2-4 provide the electrical characteristics, current consumption, and dimensions of the module. Table 2-5 shows the RF output power calibration data.

**TABLE 2-1: GENERAL SPECIFICATIONS**

Specification	Description
Frequency Band	902.000 MHz to 928.000 MHz
Modulation Method	FSK, GFSK, and LoRa <sup>®</sup> Technology modulation
Maximum Over-the-Air Data Rate	300 kbps with FSK modulation; 12500 bps with LoRa Technology modulation
RF Connection	Board edge connection
Interface	UART
Operation Range	Up to 15 km coverage at suburban; up to 5 km coverage at urban area
Sensitivity at 0.1% BER	-146 dBm <sup>(1)</sup>
RF TX Power	Adjustable up to max. +18.5 dBm on 915 MHz band <sup>(2)</sup>
Generated Conductive Harmonics Level	Below -70 dBm
Temperature (operating)	-40°C to +85°C
Temperature (storage)	-40°C to +115°C
Humidity	10% ~ 90% Non-condensing

**Note 1:** Depends on modulation. Expand Spreading Factor (SF).

**2:** TX power is adjustable. For more information, refer to the “RN2903 LoRa<sup>®</sup> Technology Module Command Reference User’s Guide” (DS40001811).

**TABLE 2-2: ELECTRICAL CHARACTERISTICS**

Parameter	Min.	Typ.	Max.	Units
Supply Voltage	2.1	—	3.6	V
Voltage on any pin with respect to VSS (except VDD)	-0.3	—	VDD + 0.3	V
Voltage on VDD with respect to VSS	-0.3	—	3.9	V
Input Clamp Current (I <sub>IK</sub> ) (V <sub>I</sub> < 0 or V <sub>I</sub> > VDD)	—	—	+/-20	mA
Output Camp Current (I <sub>OK</sub> ) (V <sub>O</sub> < 0 or V <sub>O</sub> > VDD)	—	—	+/-20	mA
GPIO sink/source current each	—	—	25/25	mA
Total GPIO sink/source current	—	—	200/185	mA
RAM Data Retention Voltage (in Sleep mode or Reset state)	1.5	—	—	V
VDD Start Voltage to ensure internal Power-on Reset signal	—	—	0.7	V
VDD Rise Rate to ensure internal Power-on Reset signal	0.05	—	—	V/ms
Brown-out Reset Voltage	1.75	1.9	2.05	V
Logic Input Low Voltage	—	—	0.15 x VDD	V
Logic Input High Voltage	0.8 x VDD	—	—	V
Input Leakage at <25°C (VSS < V <sub>PIN</sub> < VDD, Pin at high-impedance)	—	0.1	50	nA
Input Leakage at +60°C (VSS < V <sub>PIN</sub> < VDD, Pin at high-impedance)	—	0.7	100	nA
Input Leakage at +85°C (VSS < V <sub>PIN</sub> < VDD, Pin at high-impedance)	—	4	200	nA
RF Input Level	—	—	+10	dBm

**TABLE 2-3: CURRENT CONSUMPTION**

Mode	Typical Current at 3V (mA)
Idle	2.7
RX	13.5
Deep Sleep	0.002

**TABLE 2-4: MODULE DIMENSIONS**

Parameter	Value
Dimensions	17.8 x 26.7 x 3.34 mm
Weight	2.05g

**TABLE 2-5: OUTPUT POWER OF TX POWER SETTING**

TX Power Setting	Output Power (dBm)	Typical Supply Current at 3V (mA)
2	3.0	42.6
3	4.0	44.8
4	5.0	47.3
5	6.0	49.6
6	7.0	52.0
7	8.0	55.0
8	9.0	57.7
9	10.0	61.0
10	11.0	64.8
11	12.0	73.1
12	13.0	78.0
14	14.7	83.0
15	15.5	88.0
16	16.3	95.8
17	17.0	103.6
20	18.5	124.4

# RN2903

## 3.0 TYPICAL HARDWARE CONNECTIONS

Figure 3-1 shows the typical hardware connections.

**FIGURE 3-1: HARDWARE CONNECTIONS**

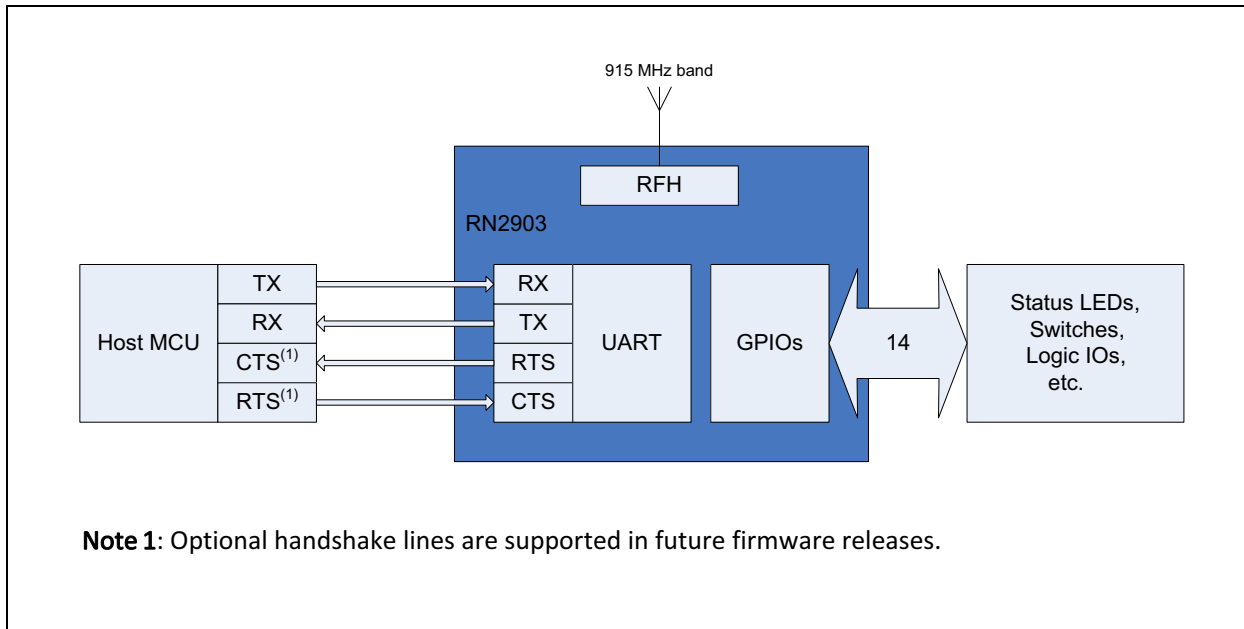

### 3.1 INTERFACE TO HOST MCU

The RN2903 module has a dedicated UART interface to communicate with a host controller. Optional handshake lines are supported in future firmware releases. The “RN2903 LoRa<sup>®</sup> Technology Module Command Reference User’s Guide” (DS40001811) provides a detailed UART command description. Table 3-1 shows the default settings for the UART communication.

**TABLE 3-1: DEFAULT UART SETTINGS**

Specification	Description
Baud Rate	57600 bps
Packet Length	8 bit
Parity Bit	No
Stop Bits	1 bit
Hardware Flow Control	No

### 3.2 GPIO PINS (GPIO0–GPIO13)

The module has 14 GPIO pins. These lines can be connected to switches, LEDs, and relay outputs. The pins can be either logic inputs or outputs, and some pins have analog input capability that can be accessed via the module firmware. These pins have limited sink and source capabilities. Electrical characteristics are described in Table 2-2. For more information, see “RN2903 LoRa<sup>®</sup> Technology Module Command Reference User’s Guide” (DS40001811).

### 3.3 RF CONNECTION

When routing RF path, use proper strip lines with an impedance of 50 Ohm.

### 3.4 RESET PIN

The Reset pin of the module is an active-low logic input.

### 3.5 POWER PINS

It is recommended to connect power pins (Pin 12 and 34) to a stable supply voltage with sufficient source current. Table 2-3 shows the current consumption.

Additional filtering capacitors are not required but used to ensure stable supply voltage in a noisy environment.



## 4.0 PHYSICAL DIMENSIONS

Figure 4-1 and Figure 4-2 illustrate the physical dimensions and the recommended PCB layout for the RN2903 module.

**FIGURE 4-1: RN2903 PHYSICAL DIMENSIONS**

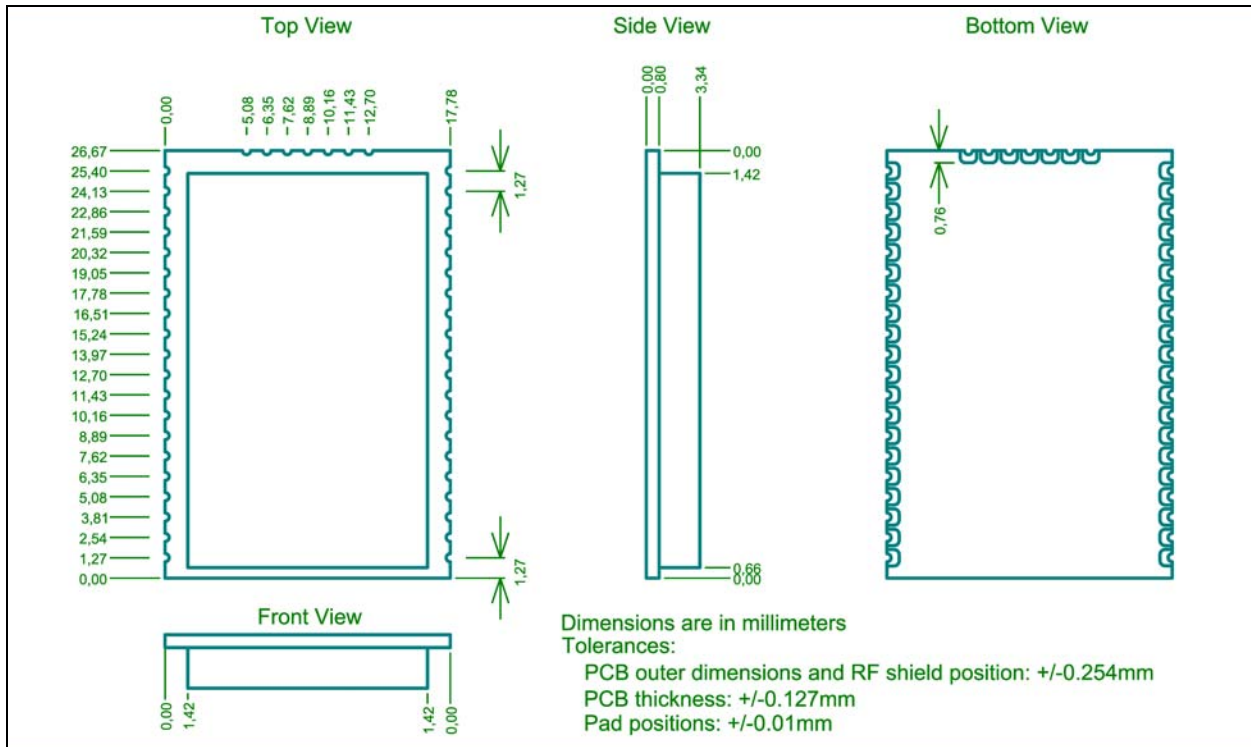

**FIGURE 4-2: RECOMMENDED PCB FOOTPRINT**

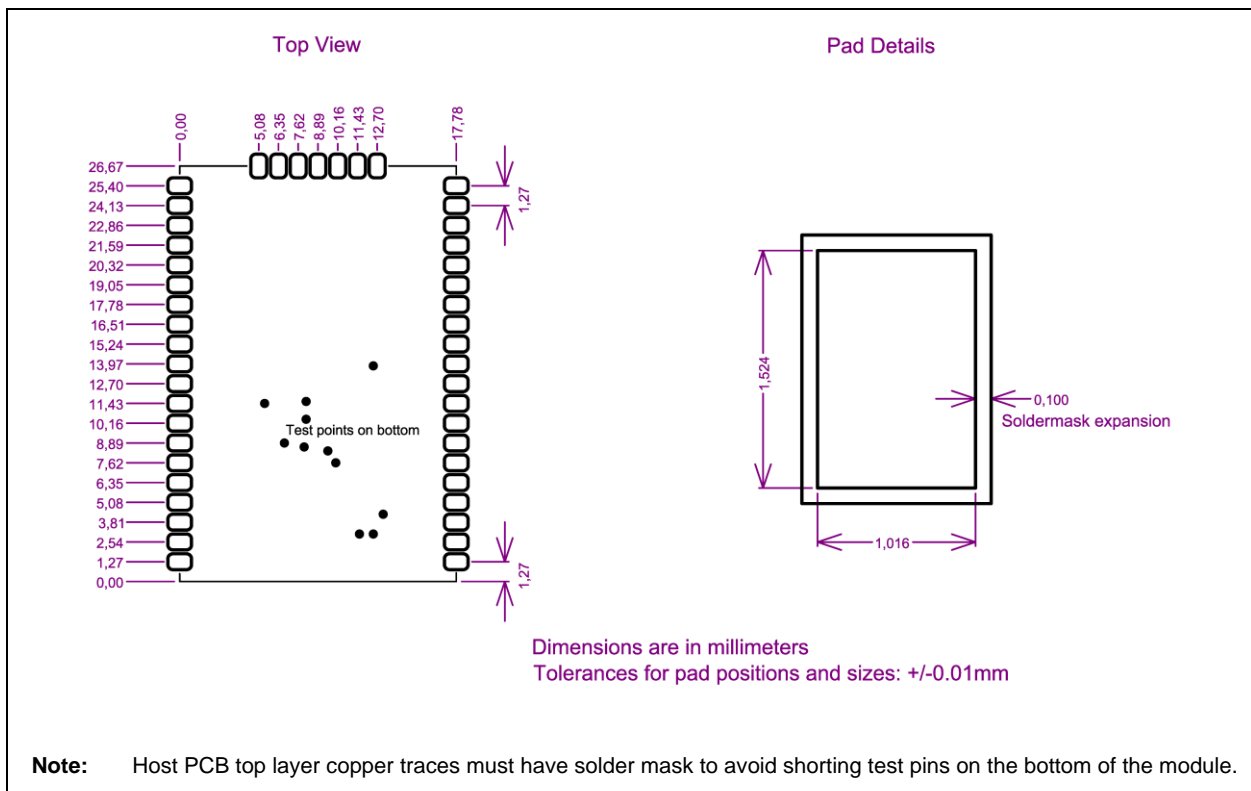

# RN2903

## 5.0 APPLICATION INFORMATION

### 5.1 RF Trace Layout Design

The RN2903 modular transmitter is certified with a PCB edge SMA connector and micro-strip trace layout as shown in Figure 5-1 and Figure 5-2. The left side RF path is not used for this module. The host PCB can follow these trace design to maintain compliance under the modular grant (FCC) and certificate (IC). Gerber files are available on the RN2903 product web page at [www.microchip.com/m2903](http://www.microchip.com/m2903).

FIGURE 5-1: RF TRACE ROUTING (TOP LAYER)

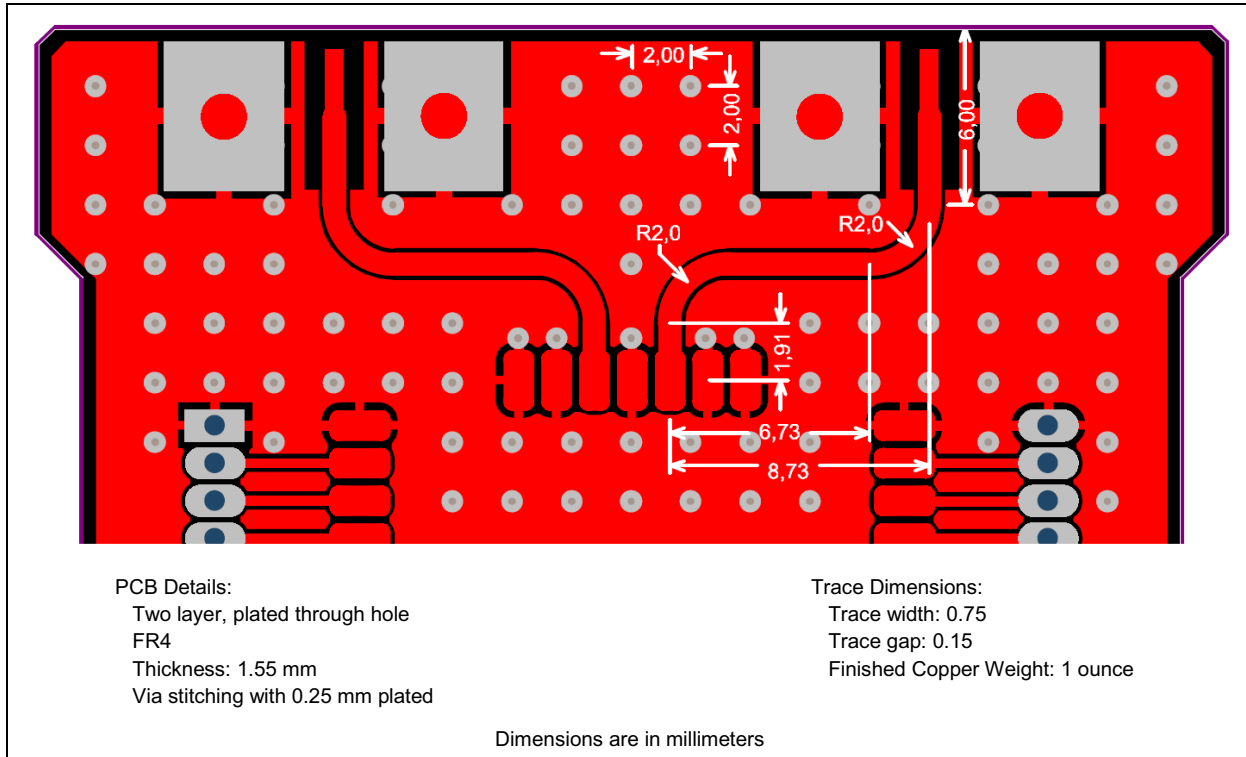
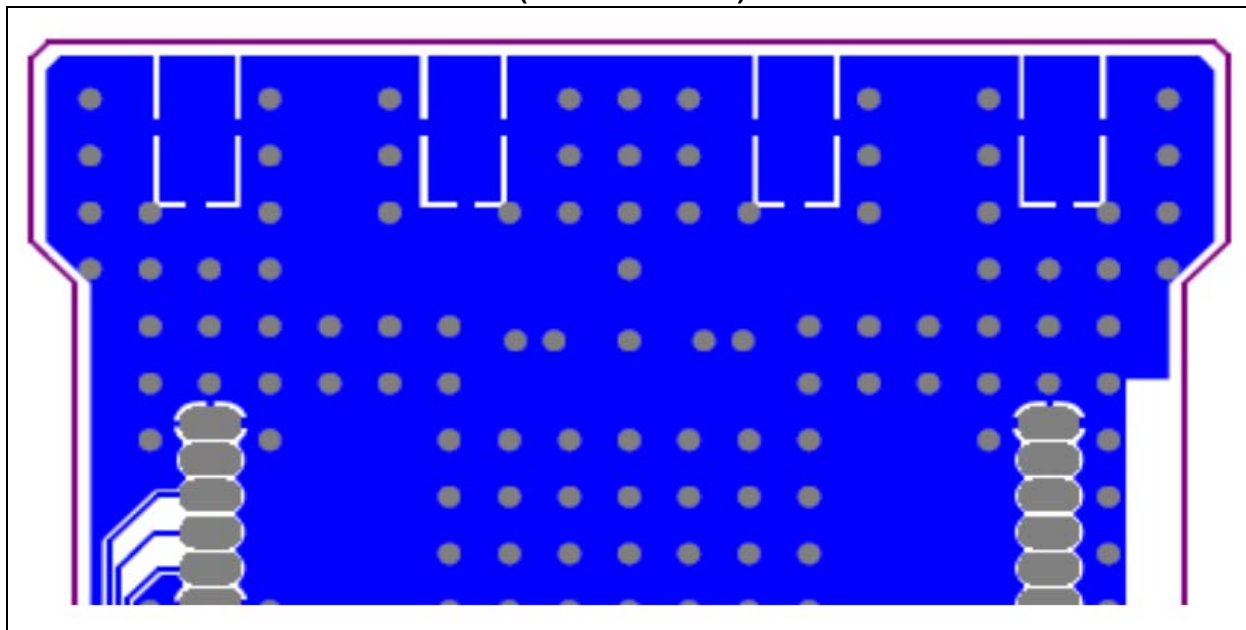

FIGURE 5-2: RF TRACE ROUTING (BOTTOM LAYER)



## 5.2 PCB Trace Antenna

Modular certification of the RN2903 module was performed with the PCB trace antenna shown in [Figure 5-3](#). The exact dimensions of the trace antenna must be followed. The PCB trace antenna is fabricated on the top copper layer and covered in solder mask. The layers below the antenna do not have copper trace. The PCB material is FR4 and the thickness is 0.062 inches (1.6 mm). Gerber files for the PCB trace antenna are available on the RN2903 product web page on the Microchip web site at <http://www.microchip.com/rn2903>.

**FIGURE 5-3: PCB TRACE ANTENNA MEASUREMENTS**

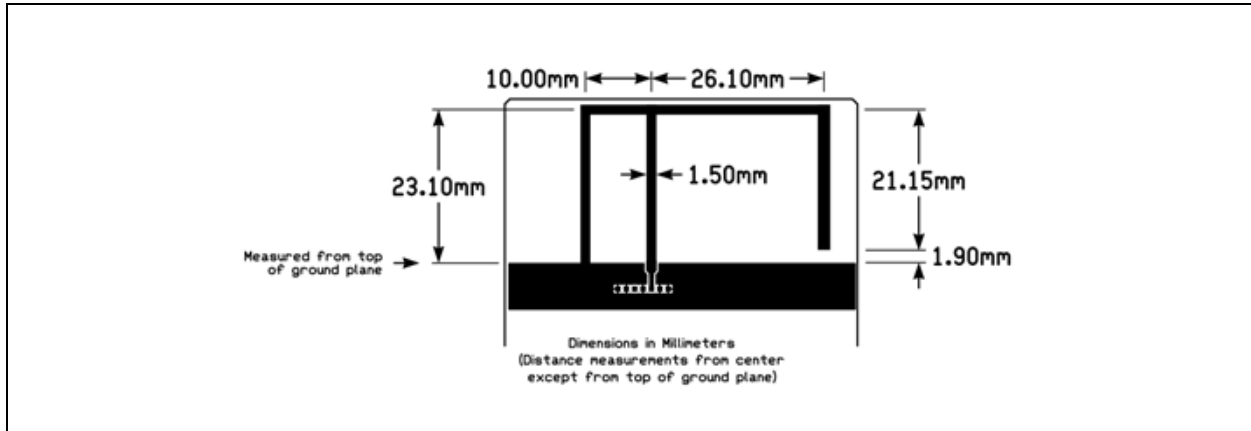

The antenna patterns plotted in [Figure 5-4](#) through [Figure 5-5](#) are the simulated results of the PCB antenna.

The two-dimensional (2D) radiation pattern is illustrated in [Figure 5-4](#). The calculated average gain is 1.3 dBi. The radiation pattern for the XZ plane is shown in red, whereas the YZ plane is shown in violet. The most powerful radiation occurs in the XZ plane as represented by the red pattern.

The three-dimensional (3D) radiation pattern is illustrated in [Figure 5-5](#). The radiation pattern shows the relative position of the 3D radiation “donut” with reference to the module orientation. This is a very useful guide for placement of the module to obtain the maximum range.

**FIGURE 5-4: SIMULATED TWO-DIMENSIONAL RADIATION PATTERN**

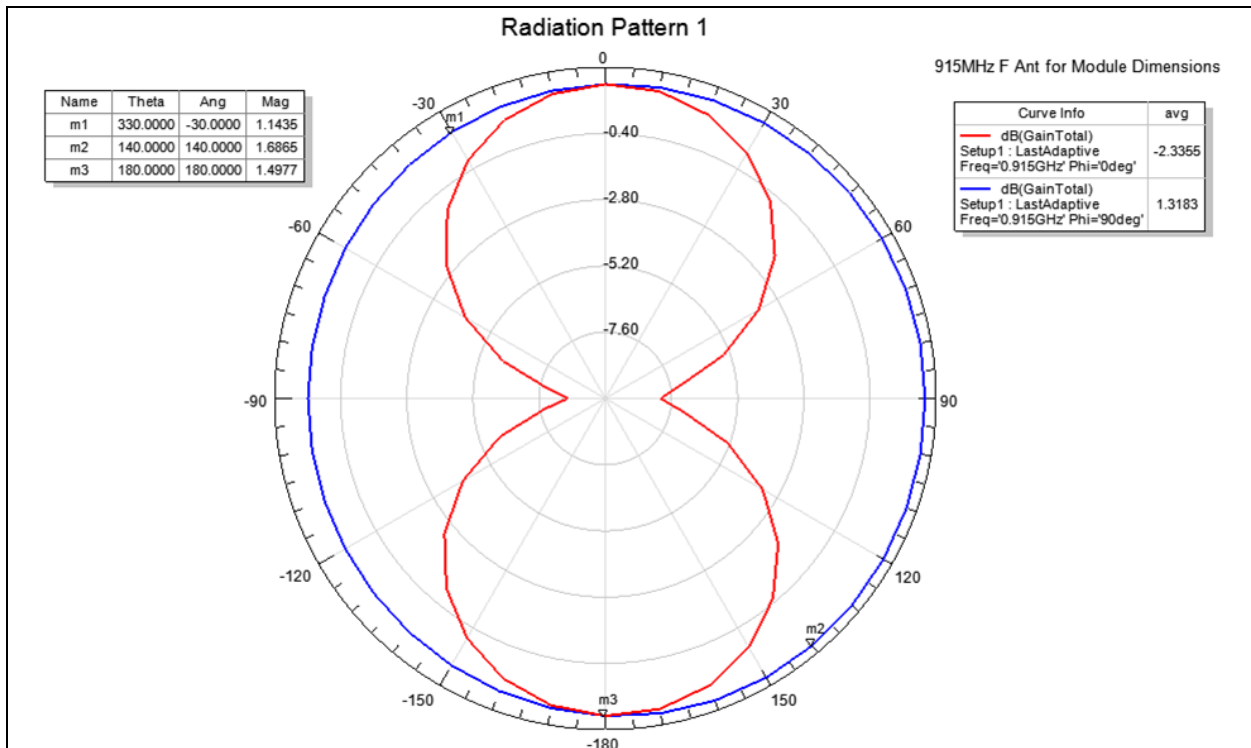

**FIGURE 5-5: SIMULATED THREE DIMENSIONAL RADIATION PATTERN**

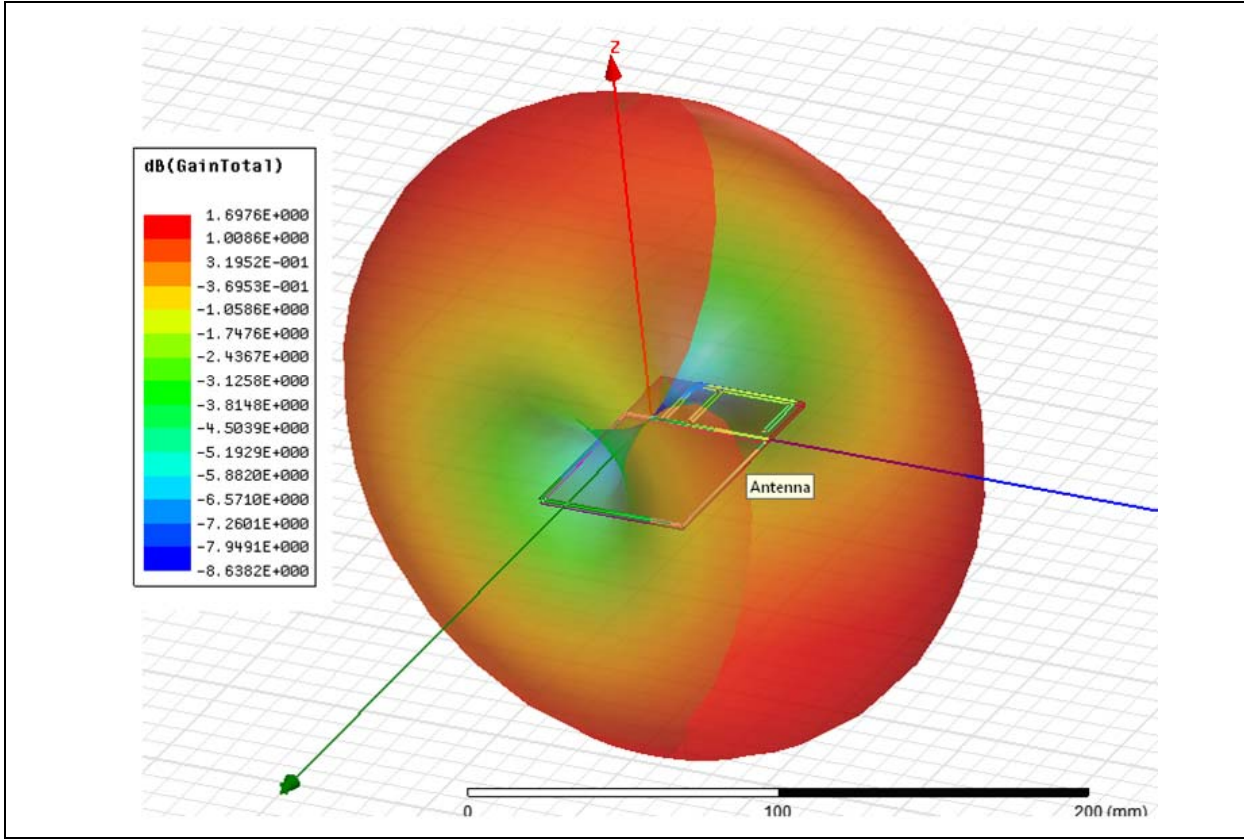

### 5.3 Approved Antennas

Modular certification of the RN2903 module is performed with the external antenna type in [Table 5-1](#). For specific regulatory requirements by country, refer to [Section 6.0 "Regulatory Approval"](#).

**TABLE 5-1: TESTED EXTERNAL ANTENNA TYPES**

Type	Gain (dBi)
Sleeve Dipole	6
PCB Trace	1.7

### 5.4 APPLICATION SCHEMATIC

Figure 5-6 shows the schematic for the RN2903 PICtail™/PICtail Plus Daughter Board.

FIGURE 5-6: PICTAIL™/PICTAIL PLUS DAUGHTER BOARD SCHEMATIC

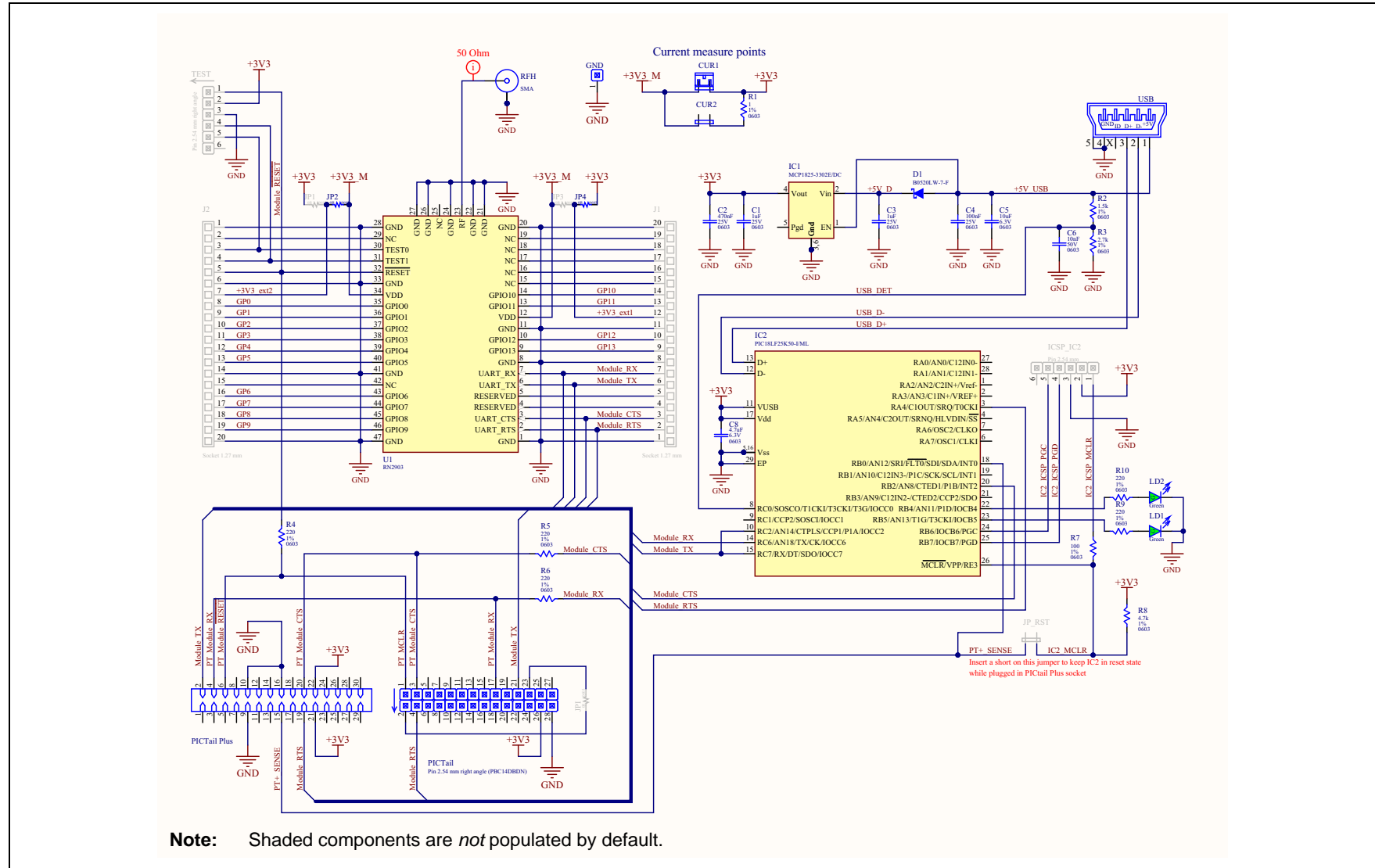

# RN2903

## 6.0 REGULATORY APPROVAL

This section outlines the regulatory information for the RN2903 module for the following countries:

- United States
- Canada
- Australia
- New Zealand

### 6.1 United States

The RN2903 module has received Federal Communications Commission (FCC) CFR47 Telecommunications, Part 15 Subpart C "Intentional Radiators" modular approval in accordance with Part 15.212 Modular Transmitter approval. Modular approval allows the end user to integrate the RN2903 module into a finished product without obtaining subsequent and separate FCC approvals for intentional radiation, provided no changes or modifications are made to the module circuitry. Changes or modifications could void the user's authority to operate the equipment. The end user must comply with all of the instructions provided by the Grantee, which indicate installation and/or operating conditions necessary for compliance.

The finished product is required to comply with all applicable FCC equipment authorizations regulations, requirements and equipment functions not associated with the transmitter module portion. For example, compliance must be demonstrated to regulations for other transmitter components within the host product; to requirements for unintentional radiators (Part 15 Subpart B "Unintentional Radiators"), such as digital devices, computer peripherals, radio receivers, etc.; and to additional authorization requirements for the non-transmitter functions on the transmitter module (i.e., Verification, or Declaration of Conformity) (e.g., transmitter modules may also contain digital logic functions) as appropriate.

### 6.1.1 LABELING AND USER INFORMATION REQUIREMENTS

The RN2903 module has been labeled with its own FCC ID number, and if the FCC ID is not visible when the module is installed inside another device, then the outside of the finished product into which the module is installed must also display a label referring to the enclosed module. This exterior label can use wording as follows:

Contains Transmitter Module FCC ID: T9JRN2903  or  Contains FCC ID: T9JRN2903  This device complies with Part 15 of the FCC Rules. Operation is subject to the following two conditions: (1) this device may not cause harmful interference, and (2) this device must accept any interference received, including interference that may cause undesired operation.
--

A user's manual for the finished product should include the following statement:

This equipment has been tested and found to comply with the limits for a Class B digital device, pursuant to part 15 of the FCC Rules. These limits are designed to provide reasonable protection against harmful interference in a residential installation. This equipment generates, uses and can radiate radio frequency energy, and if not installed and used in accordance with the instructions, may cause harmful interference to radio communications. However, there is no guarantee that interference will not occur in a particular installation. If this equipment does cause harmful interference to radio or television reception, which can be determined by turning the equipment off and on, the user is encouraged to try to correct the interference by one or more of the following measures: <ul style="list-style-type: none"><li>• Reorient or relocate the receiving antenna.</li><li>• Increase the separation between the equipment and receiver.</li><li>• Connect the equipment into an outlet on a circuit different from that to which the receiver is connected.</li><li>• Consult the dealer or an experienced radio/TV technician for help.</li></ul>
---

Additional information on labeling and user information requirements for Part 15 devices can be found in KDB Publication 784748 available at the FCC Office of Engineering and Technology (OET) Laboratory Division Knowledge Database (KDB)  
<https://apps.fcc.gov/oetcf/kdb/index.cfm>.

## 6.1.2 RF EXPOSURE

All transmitters regulated by FCC must comply with RF exposure requirements. KDB 447498 General RF Exposure Guidance provides guidance in determining whether proposed or existing transmitting facilities, operations or devices comply with limits for human exposure to Radio Frequency (RF) fields adopted by the Federal Communications Commission (FCC).

From the RN2903 FCC Grant: Output power listed is conducted. This grant is valid only when the module is sold to OEM integrators and must be installed by the OEM or OEM integrators. This transmitter is restricted for use with the specific antenna(s) tested in this application for Certification and must not be co-located or operating in conjunction with any other antenna or transmitters within a host device, except in accordance with FCC multi-transmitter product procedures.

## 6.1.3 APPROVED EXTERNAL ANTENNA TYPES

To maintain modular approval in the United States, only the antenna types that have been tested shall be used. It is permissible to use different antenna manufacturer provided the same antenna type and antenna gain (equal to or less than) is used.

Testing of the RN2903 module was performed with the antenna types listed in [Table 5-1](#) Tested External Antenna Types.

## 6.1.4 HELPFUL WEB SITES

Federal Communications Commission (FCC):  
<http://www.fcc.gov>

FCC Office of Engineering and Technology (OET) Laboratory Division Knowledge Database (KDB):  
<https://apps.fcc.gov/oetcf/kdb/index.cfm>

## 6.2 Canada

The RN2903 module has been certified for use in Canada under Industry Canada (IC) Radio Standards Specification (RSS) RSS-210 and RSS-Gen. Modular approval permits the installation of a module in a host device without the need to recertify the device.

### 6.2.1 LABELING AND USER INFORMATION REQUIREMENTS

Labeling Requirements for the Host Device (from Section 3.2.1, RSS-Gen, Issue 3, December 2010): The host device shall be properly labeled to identify the module within the host device.

The Industry Canada certification label of a module shall be clearly visible at all times when installed in the host device, otherwise the host device must be labeled to display the Industry Canada certification number of

the module, preceded by the words "Contains transmitter module", or the word "Contains", or similar wording expressing the same meaning, as follows:

Contains transmitter module IC: 6514A-RN2903.

User Manual Notice for License-Exempt Radio Apparatus (from Section 7.1.3 RSS-Gen, Issue 3, December 2010): User manuals for license-exempt radio apparatus shall contain the following or equivalent notice in a conspicuous location in the user manual or alternatively on the device or both:

This device complies with Industry Canada license-exempt RSS standard(s). Operation is subject to the following two conditions: (1) this device may not cause interference, and (2) this device must accept any interference, including interference that may cause undesired operation of the device.

Le présent appareil est conforme aux CNR d'Industrie Canada applicables aux appareils radio exempts de licence. L'exploitation est autorisée aux deux conditions suivantes: (1) l'appareil ne doit pas produire de brouillage, et (2) l'utilisateur de l'appareil doit accepter tout brouillage radioélectrique subi, même si le brouillage est susceptible d'en compromettre le fonctionnement.

Transmitter Antenna (from Section 7.1.2 RSS-Gen, Issue 3, December 2010): User manuals for transmitters shall display the following notice in a conspicuous location:

Under Industry Canada regulations, this radio transmitter may only operate using an antenna of a type and maximum (or lesser) gain approved for the transmitter by Industry Canada. To reduce potential radio interference to other users, the antenna type and its gain should be so chosen that the equivalent isotropically radiated power (e.i.r.p.) is not more than that necessary for successful communication.

Conformément à la réglementation d'Industrie Canada, le présent émetteur radio peut fonctionner avec une antenne d'un type et d'un gain maximal (ou inférieur) approuvé pour l'émetteur par Industrie Canada. Dans le but de réduire les risques de brouillage radioélectrique à l'intention des autres utilisateurs, il faut choisir le type d'antenne et son gain de sorte que la puissance isotrope rayonnée équivalente (p.i.r.e.) ne dépasse pas l'intensité nécessaire à l'établissement d'une communication satisfaisante.

The above notice may be affixed to the device instead of displayed in the user manual.

User manuals for transmitters equipped with detachable antennas shall also contain the following notice in a conspicuous location:

This radio transmitter (identify the device by certification number, or model number if Category II) has been approved by Industry Canada to operate with the antenna types listed below with the maximum permissible gain and required antenna impedance for each antenna type indicated. Antenna types not included in this list, having a gain greater than the maximum gain indicated for that type, are strictly prohibited for use with this device.

Conformément à la réglementation d'Industrie Canada, le présent émetteur radio peut fonctionner avec une antenne d'un type et d'un gain maximal (ou inférieur) approuvé pour l'émetteur par Industrie Canada. Dans le but de réduire les risques de brouillage radioélectrique à l'intention des autres utilisateurs, il faut choisir le type d'antenne et son gain de sorte que la puissance isotrope rayonnée équivalente (p.i.r.e.) ne dépasse pas l'intensité nécessaire à l'établissement d'une communication satisfaisante.

Immediately following the above notice, the manufacturer shall provide a list of all antenna types approved for use with the transmitter, indicating the maximum permissible antenna gain (in dBi) and required impedance for each.

## 6.2.2 APPROVED EXTERNAL ANTENNA TYPES

Transmitter Antenna (from Section 7.1.2 RSS-Gen, Issue 3, December 2010):

The RN2903 module can only be sold or operated with antennas with which it was approved. Transmitter may be approved with multiple antenna types. An antenna type comprises antennas having similar in-band and out-of-band radiation patterns. Testing shall be performed using the highest gain antenna of each combination of transmitter and antenna type for which approval is being sought, with the transmitter output power set at the maximum level. Any antenna of the same type having equal or lesser gain as an antenna that had been successfully tested with the transmitter, will also be considered approved with the transmitter, and may be used and marketed with the transmitter.

When a measurement at the antenna connector is used to determine RF output power, the effective gain of the device's antenna shall be stated, based on measurement or on data from the antenna manufacturer. For transmitters of output power greater than 10 milliwatts, the total antenna gain shall be added to the measured RF output power to demonstrate compliance to the specified radiated power limits.

Testing of the RN2903 module was performed with the antenna types listed in [Table 5-1](#) Tested External Antenna Types.

## 6.2.3 HELPFUL WEB SITES

Industry Canada: <http://www.ic.gc.ca/>

## 6.3 Australia

RN2903 module RF transmitter test reports can be used in part to demonstrate compliance in accordance with ACMA Radio communications "Short Range Devices" Standard 2004 (The Short Range Devices standard calls up the AS/NZS 4268:2008 industry standard). The MRF89XAM9A module test reports can be used as part of the product certification and compliance folder. For more information on the RF transmitter test reports, contact Microchip Technology Australia office.

AS/NZS 4268:2008 refers to the USA FCC 15.247 RF standards, the frequency limits of 915 - 928 MHz apply in Australia.

To meet overall Australian end product compliance, the integrator must construct a compliance folder containing all relevant compliance test reports e.g. RF, EMC, electrical safety and DoC (Declaration of Conformity) etc. It is the responsibility of the integrator to know what is required in the compliance folder for ACMA compliance. For more information on Australia compliance, refer to the Australian Communications and Media Authority web site <http://www.acma.gov.au/>.

## 6.3.1 HELPFUL WEB SITES

The Australian Communications and Media Authority: <http://www.acma.gov.au/>



## 6.4 New Zealand

RN2903 module RF transmitter test reports can be used in part to demonstrate compliance against the New Zealand "General User Radio License for Short Range Devices". New Zealand Radio communications (Radio Standards) Notice 2010 calls up the AS / NZS 4268:2008 industry standard. The RN2903 module test reports can be used as part of the product certification and compliance folder. For more information on the RF transmitter test reports, contact Microchip Technology.

Information on the New Zealand short range devices license can be found in the following web links:

<http://www.rsm.govt.nz/cms/licensees/types-of/licence/general-user-licences/short-range-devices>

and

<http://www.rsm.govt.nz/about-rsm/spectrum-policy>

While the AS /NZS 4268:2008 refers to the USA FCC 15.247 and EN 300 220-1 V2.3.1 RF standards, the frequency limits of 921 MHz to 928 MHz apply in New Zealand.

To meet overall New Zealand end product compliance, the developer must construct a compliance folder containing all relevant compliance test reports e.g. RF, EMC, electrical safety and DoC (Declaration of Conformity) etc. It is the responsibility of the developer to know what is required in the compliance folder for New Zealand Radio communications. For more information on New Zealand compliance, refer to the web site <http://www.rsm.govt.nz/>.

### 6.4.1 HELPFUL WEB SITES

Radio Spectrum Ministry of Economic Development:  
<http://www.rsm.govt.nz/>

# RN2903

---

NOTES:

## APPENDIX A: REVISION HISTORY

### Revision A (July 2015)

This is the initial release of this document.

### Revision B (December 2015)

This revision includes the following updates:

- Updated Deep Sleep value in [Table 2-3 "Current Consumption"](#).
- Updated Dimensions value in [Table 2-4 "Module Dimensions"](#).
- Updated [Figure 4-1](#).
- Updated [Figure 4-2](#).
- Updated [Figure 5-2](#).
- Updated information for [Section 5.1 "RF Trace Layout Design"](#).

# RN2903

---

NOTES:

## THE MICROCHIP WEB SITE

Microchip provides online support via our WWW site at [www.microchip.com](http://www.microchip.com). This web site is used as a means to make files and information easily available to customers. Accessible by using your favorite Internet browser, the web site contains the following information:

- **Product Support** – Data sheets and errata, application notes and sample programs, design resources, user's guides and hardware support documents, latest software releases and archived software
- **General Technical Support** – Frequently Asked Questions (FAQ), technical support requests, online discussion groups, Microchip consultant program member listing
- **Business of Microchip** – Product selector and ordering guides, latest Microchip press releases, listing of seminars and events, listings of Microchip sales offices, distributors and factory representatives

## CUSTOMER CHANGE NOTIFICATION SERVICE

Microchip's customer notification service helps keep customers current on Microchip products. Subscribers will receive e-mail notification whenever there are changes, updates, revisions or errata related to a specified product family or development tool of interest.

To register, access the Microchip web site at [www.microchip.com](http://www.microchip.com). Under "Support", click on "Customer Change Notification" and follow the registration instructions.

## CUSTOMER SUPPORT

Users of Microchip products can receive assistance through several channels:

- Distributor or Representative
- Local Sales Office
- Field Application Engineer (FAE)
- Technical Support

Customers should contact their distributor, representative or Field Application Engineer (FAE) for support. Local sales offices are also available to help customers. A listing of sales offices and locations is included in the back of this document.

**Technical support is available through the web site at: <http://microchip.com/support>**

# RN2903

---

NOTES:

## PRODUCT IDENTIFICATION SYSTEM

To order or obtain information, e.g., on pricing or delivery, refer to the factory or the listed sales office.

<u>PART NO.</u>			
Device	Temperature Range	Package	Firmware Revision Number
<b>Device:</b>	RN2903:	Low-Power Long Range LoRa® Technology Transceiver module	
<b>Temperature Range:</b>	I	=	-40°C to +85°C (Industrial)
<b>Package:</b>	RM	=	Radio Module

**Examples:**  
RN2903-I/RM: Industrial temperature

# RN2903

---

NOTES:



---

**Note the following details of the code protection feature on Microchip devices:**

- Microchip products meet the specification contained in their particular Microchip Data Sheet.
- Microchip believes that its family of products is one of the most secure families of its kind on the market today, when used in the intended manner and under normal conditions.
- There are dishonest and possibly illegal methods used to breach the code protection feature. All of these methods, to our knowledge, require using the Microchip products in a manner outside the operating specifications contained in Microchip's Data Sheets. Most likely, the person doing so is engaged in theft of intellectual property.
- Microchip is willing to work with the customer who is concerned about the integrity of their code.
- Neither Microchip nor any other semiconductor manufacturer can guarantee the security of their code. Code protection does not mean that we are guaranteeing the product as “unbreakable.”

Code protection is constantly evolving. We at Microchip are committed to continuously improving the code protection features of our products. Attempts to break Microchip's code protection feature may be a violation of the Digital Millennium Copyright Act. If such acts allow unauthorized access to your software or other copyrighted work, you may have a right to sue for relief under that Act.

---

Information contained in this publication regarding device applications and the like is provided only for your convenience and may be superseded by updates. It is your responsibility to ensure that your application meets with your specifications. MICROCHIP MAKES NO REPRESENTATIONS OR WARRANTIES OF ANY KIND WHETHER EXPRESS OR IMPLIED, WRITTEN OR ORAL, STATUTORY OR OTHERWISE, RELATED TO THE INFORMATION, INCLUDING BUT NOT LIMITED TO ITS CONDITION, QUALITY, PERFORMANCE, MERCHANTABILITY OR FITNESS FOR PURPOSE. Microchip disclaims all liability arising from this information and its use. Use of Microchip devices in life support and/or safety applications is entirely at the buyer's risk, and the buyer agrees to defend, indemnify and hold harmless Microchip from any and all damages, claims, suits, or expenses resulting from such use. No licenses are conveyed, implicitly or otherwise, under any Microchip intellectual property rights unless otherwise stated.

#### **Trademarks**

The Microchip name and logo, the Microchip logo, dsPIC, FlashFlex, flexPWR, JukeBlox, KEELOQ, KEELOQ logo, Klear, LANCheck, MediaLB, MOST, MOST logo, MPLAB, OptoLyzer, PIC, PICSTART, PIC<sup>32</sup> logo, RightTouch, SpyNIC, SST, SST Logo, SuperFlash and UNI/O are registered trademarks of Microchip Technology Incorporated in the U.S.A. and other countries.

The Embedded Control Solutions Company and mTouch are registered trademarks of Microchip Technology Incorporated in the U.S.A.

Analog-for-the-Digital Age, BodyCom, chipKIT, chipKIT logo, CodeGuard, dsPICDEM, dsPICDEM.net, ECAN, In-Circuit Serial Programming, ICSP, Inter-Chip Connectivity, KlearNet, KlearNet logo, MiWi, motorBench, MPASM, MPF, MPLAB Certified logo, MPLIB, MPLINK, MultiTRAK, NetDetach, Omniscient Code Generation, PICDEM, PICDEM.net, PICkit, PICtail, RightTouch logo, REAL ICE, SQI, Serial Quad I/O, Total Endurance, TSHARC, USBCheck, VariSense, ViewSpan, WiperLock, Wireless DNA, and ZENA are trademarks of Microchip Technology Incorporated in the U.S.A. and other countries.

SQTP is a service mark of Microchip Technology Incorporated in the U.S.A.

Silicon Storage Technology is a registered trademark of Microchip Technology Inc. in other countries.

GestIC is a registered trademark of Microchip Technology Germany II GmbH & Co. KG, a subsidiary of Microchip Technology Inc., in other countries.

All other trademarks mentioned herein are property of their respective companies.

© 2015, Microchip Technology Incorporated, Printed in the U.S.A., All Rights Reserved.

ISBN: 978-1-5224-0102-5

**QUALITY MANAGEMENT SYSTEM**  
**CERTIFIED BY DNV**  
**== ISO/TS 16949 ==**

*Microchip received ISO/TS-16949:2009 certification for its worldwide headquarters, design and wafer fabrication facilities in Chandler and Tempe, Arizona; Gresham, Oregon and design centers in California and India. The Company's quality system processes and procedures are for its PIC® MCUs and dsPIC® DSCs, KEELOQ® code hopping devices, Serial EEPROMs, microperipherals, nonvolatile memory and analog products. In addition, Microchip's quality system for the design and manufacture of development systems is ISO 9001:2000 certified.*



# MICROCHIP

## Worldwide Sales and Service

### AMERICAS

#### Corporate Office

2355 West Chandler Blvd.  
Chandler, AZ 85224-6199

Tel: 480-792-7200

Fax: 480-792-7277

Technical Support:

[http://www.microchip.com/  
support](http://www.microchip.com/support)

Web Address:

[www.microchip.com](http://www.microchip.com)

#### Atlanta

Duluth, GA

Tel: 678-957-9614

Fax: 678-957-1455

#### Austin, TX

Tel: 512-257-3370

#### Boston

Westborough, MA

Tel: 774-760-0087

Fax: 774-760-0088

#### Chicago

Itasca, IL

Tel: 630-285-0071

Fax: 630-285-0075

#### Cleveland

Independence, OH

Tel: 216-447-0464

Fax: 216-447-0643

#### Dallas

Addison, TX

Tel: 972-818-7423

Fax: 972-818-2924

#### Detroit

Novi, MI

Tel: 248-848-4000

#### Houston, TX

Tel: 281-894-5983

#### Indianapolis

Noblesville, IN

Tel: 317-773-8323

Fax: 317-773-5453

#### Los Angeles

Mission Viejo, CA

Tel: 949-462-9523

Fax: 949-462-9608

#### New York, NY

Tel: 631-435-6000

#### San Jose, CA

Tel: 408-735-9110

#### Canada - Toronto

Tel: 905-673-0699

Fax: 905-673-6509

### ASIA/PACIFIC

#### Asia Pacific Office

Suites 3707-14, 37th Floor  
Tower 6, The Gateway  
Harbour City, Kowloon

#### Hong Kong

Tel: 852-2943-5100

Fax: 852-2401-3431

#### Australia - Sydney

Tel: 61-2-9868-6733

Fax: 61-2-9868-6755

#### China - Beijing

Tel: 86-10-8569-7000

Fax: 86-10-8528-2104

#### China - Chengdu

Tel: 86-28-8665-5511

Fax: 86-28-8665-7889

#### China - Chongqing

Tel: 86-23-8980-9588

Fax: 86-23-8980-9500

#### China - Dongguan

Tel: 86-769-8702-9880

#### China - Hangzhou

Tel: 86-571-8792-8115

Fax: 86-571-8792-8116

#### China - Hong Kong SAR

Tel: 852-2943-5100

Fax: 852-2401-3431

#### China - Nanjing

Tel: 86-25-8473-2460

Fax: 86-25-8473-2470

#### China - Qingdao

Tel: 86-532-8502-7355

Fax: 86-532-8502-7205

#### China - Shanghai

Tel: 86-21-5407-5533

Fax: 86-21-5407-5066

#### China - Shenyang

Tel: 86-24-2334-2829

Fax: 86-24-2334-2393

#### China - Shenzhen

Tel: 86-755-8864-2200

Fax: 86-755-8203-1760

#### China - Wuhan

Tel: 86-27-5980-5300

Fax: 86-27-5980-5118

#### China - Xian

Tel: 86-29-8833-7252

Fax: 86-29-8833-7256

### ASIA/PACIFIC

#### China - Xiamen

Tel: 86-592-2388138

Fax: 86-592-2388130

#### China - Zhuhai

Tel: 86-756-3210040

Fax: 86-756-3210049

#### India - Bangalore

Tel: 91-80-3090-4444

Fax: 91-80-3090-4123

#### India - New Delhi

Tel: 91-11-4160-8631

Fax: 91-11-4160-8632

#### India - Pune

Tel: 91-20-3019-1500

#### Japan - Osaka

Tel: 81-6-6152-7160

Fax: 81-6-6152-9310

#### Japan - Tokyo

Tel: 81-3-6880-3770

Fax: 81-3-6880-3771

#### Korea - Daegu

Tel: 82-53-744-4301

Fax: 82-53-744-4302

#### Korea - Seoul

Tel: 82-2-554-7200

Fax: 82-2-558-5932 or

82-2-558-5934

#### Malaysia - Kuala Lumpur

Tel: 60-3-6201-9857

Fax: 60-3-6201-9859

#### Malaysia - Penang

Tel: 60-4-227-8870

Fax: 60-4-227-4068

#### Philippines - Manila

Tel: 63-2-634-9065

Fax: 63-2-634-9069

#### Singapore

Tel: 65-6334-8870

Fax: 65-6334-8850

#### Taiwan - Hsin Chu

Tel: 886-3-5778-366

Fax: 886-3-5770-955

#### Taiwan - Kaohsiung

Tel: 886-7-213-7828

#### Taiwan - Taipei

Tel: 886-2-2508-8600

Fax: 886-2-2508-0102

#### Thailand - Bangkok

Tel: 66-2-694-1351

Fax: 66-2-694-1350

### EUROPE

#### Austria - Wels

Tel: 43-7242-2244-39

Fax: 43-7242-2244-393

#### Denmark - Copenhagen

Tel: 45-4450-2828

Fax: 45-4485-2829

#### France - Paris

Tel: 33-1-69-53-63-20

Fax: 33-1-69-30-90-79

#### Germany - Dusseldorf

Tel: 49-2129-3766400

#### Germany - Munich

Tel: 49-89-627-144-0

Fax: 49-89-627-144-44

#### Germany - Pforzheim

Tel: 49-7231-424750

#### Italy - Milan

Tel: 39-0331-742611

Fax: 39-0331-466781

#### Italy - Venice

Tel: 39-049-7625286

#### Netherlands - Drunen

Tel: 31-416-690399

Fax: 31-416-690340

#### Poland - Warsaw

Tel: 48-22-3325737

#### Spain - Madrid

Tel: 34-91-708-08-90

Fax: 34-91-708-08-91

#### Sweden - Stockholm

Tel: 46-8-5090-4654

#### UK - Wokingham

Tel: 44-118-921-5800

Fax: 44-118-921-5820

07/14/15