

RADIO TEST REPORT

Test Report No. : 30GE0232-HO-02-C-R1

Applicant : Ricoh Company, Ltd.
Type of Equipment : Module Circuit Board
Model No. : SG4G2-TB3
FCC ID : T9FG700SE
Test regulation : FCC Part 15 Subpart C 2010
Test Result : Complied

1. This test report shall not be reproduced in full or partial, without the written approval of UL Japan, Inc.
2. The results in this report apply only to the sample tested.
3. This sample tested is in compliance with the above regulation.
4. The test results in this report are traceable to the national or international standards.
5. This test report must not be used by the customer to claim product certification, approval, or endorsement by NVLAP, NIST, or any agency of the Federal Government.
6. This report is a revised version of 30GE0232-HO-02-C.
30GE0232-HO-02-C is replaced with this report.

Date of test: June 4 to October 13, 2010

**Representative
test engineer:** 
Takeshi Choda
Engineer of EMC Service

Approved by: 
Takahiro Hatakeda
Leader of EMC Service



NVLAP LAB CODE: 200572-0

This laboratory is accredited by the NVLAP LAB CODE 200572-0, U.S.A. The tests reported herein have been performed in accordance with its terms of accreditation.
*As for the range of Accreditation in NVLAP, you may refer to the WEB address,
<http://www.ul.com/japan/jpn/pages/services/emc/about/mark1/index.jsp#nvlap>

CONTENTS	PAGE
SECTION 1: Customer information.....	3
SECTION 2: Equipment under test (E.U.T.).....	3
SECTION 3: Test specification, procedures & results.....	4
SECTION 4: Operation of E.U.T. during testing.....	8
SECTION 5: Conducted Emission.....	11
SECTION 6: Radiated Spurious Emission	12
SECTION 7: Antenna Terminal Conducted Tests.....	13
APPENDIX 1: Photographs of test setup	14
Conducted Emission	14
Radiated Spurious Emission	15
Worst Case Position	16
APPENDIX 2: Data of EMI test.....	17
Conducted Emission	17
20dB Bandwidth and Carrier Frequency Separation.....	22
Number of Hopping Frequency	25
Dwell time	27
Maximum Peak Output Power	30
Radiated Spurious Emission	31
Conducted Spurious Emission	44
Conducted Emission Band Edge compliance	51
99%Occupied Bandwidth	53
APPENDIX 3: Test instruments	55

SECTION 1: Customer information

Company Name : Ricoh Company, Ltd. *
Address : 8-13-1 Ricoh building, Ginza, Chuo-ku, Tokyo-to 104-8222, Japan
Telephone Number : +81-45-475-7499
Facsimile Number : +81-45-475-2799
Contact Person : Daisuke Fujioka

***Remarks:**

Ricoh Company, Ltd. designates SANYO Electric Co., Ltd. as manufacturer of the product (Module Circuit Board).

SECTION 2: Equipment under test (E.U.T.)

2.1 Identification of E.U.T.

Type of Equipment : Module Circuit Board
Model No. : SG4G2-TB3
Serial No. : Refer to Section 4, Clause 4.2
Rating : DC3.3V, DC4.2V
Receipt Date of Sample : June 2, 2010
Country of Mass-production : Vietnam
Condition of EUT : Production prototype
(Not for Sale: This sample is equivalent to mass-produced items.)
Modification of EUT : No Modification by the test lab

2.2 Product Description

Model No: SG4G2-TB3 (referred to as the EUT in this report) is the Module Circuit Board which is installed in the Digital Camera (host device) manufactured by Ricoh Company, Ltd..

Equipment Type : Transceiver
Clock frequency : 26MHz(Bluetooth part/Wireless LAN part), 32.768kHz
Method of Frequency Generation : Synthesizer
Operating temperature range : -10 to +40 deg. C.

This EUT has multi transmitters of Wireless LAN and Bluetooth.

However, this EUT doesn't have the simultaneous transmission since these two communication methods share the same one antenna.

	IEEE802.11b	IEEE802.11g	Bluetooth
Frequency of operation	2412-2462MHz	2412-2462MHz	2402-2480MHz
Type of modulation	DSSS	OFDM	FHSS
Bandwidth & Channel spacing	20M & 5MHz	20M & 5MHz	1MHz & 1MHz
Antenna type	Chip Multilayer antenna (LDA312G4413H-280)		
Antenna Gain	3.4dBi max		
Operating voltage (Inner)	DC3.3V & DC1.8V		DC3.3V

* This test report is for Bluetooth part. As for Wireless LAN part, please see test report No.: 30GE0232-HO-02-A.

UL Japan, Inc.

Head Office EMC Lab.

4383-326 Asama-cho, Ise-shi, Mie-ken 516-0021 JAPAN

Telephone : +81 596 24 8116

Facsimile : +81 596 24 8124

SECTION 3: Test specification, procedures & results

3.1 Test Specification

Test Specification : FCC Part15 Subpart C: 2010, final revised on January 22, 2010 and effective March 1, 2010

Title : FCC 47CFR Part15 Radio Frequency Device Subpart C Intentional Radiators
Section 15.207 Conducted limits
Section 15.247 Operation within the bands 902-928MHz,
2400-2483.5MHz, and 5725-5850MHz

3.2 Procedures and results

Item	Test Procedure	Specification	Worst Margin	Results	Remarks
Conducted Emission	FCC: ANSI C63.4:2003 7. AC powerline conducted emission measurements IC: RSS-Gen 7.2.2	FCC: Section 15.207 ----- IC: RSS-Gen 7.2.2	QP 13.2dB, (0.18082MHz, N) (0.18124MHz, N) AV 16.7dB, 0.37797MHz, N	Complied	-
Carrier Frequency Separation	FCC: FCC Public Notice DA 00-705 ----- IC: -	FCC: Section 15.247(a)(1) ----- IC: RSS-210 A8.1 (b)	See data.	Complied	Conducted
20dB Bandwidth	FCC: FCC Public Notice DA 00-705 ----- IC: -	FCC: Section 15.247(a)(1) ----- IC: RSS-210 A8.1 (a)		N/A	Conducted
Number of Hopping Frequency	FCC: FCC Public Notice DA 00-705 ----- IC: -	FCC: Section 15.247(a)(1)(iii) ----- IC: RSS-210 A8.1 (d)		Complied	Conducted
Dwell time	FCC: FCC Public Notice DA 00-705 ----- IC: -	FCC: Section 15.247(a)(1)(iii) ----- IC: RSS-210 A8.1 (d)		Complied	Conducted
Maximum Peak Output Power	FCC: FCC Public Notice DA 00-705 ----- IC: RSS-Gen 4.8	FCC: Section 15.247(b)(1) ----- IC: RSS-210 A8.4 (2)		Complied	Conducted
Spurious Emission & Band Edge Compliance	FCC: FCC Public Notice DA 00-705 ----- IC: RSS-Gen 4.9 RSS-Gen 4.10	FCC: Section 15.247(d) ----- IC: RSS-210 A8.5 RSS-Gen 7.2.1 and 7.2.3		[Tx] 4.4dB 2483.500MHz, PK, Hori. [Rx] 6.4dB 797.991MHz, QP, Hori.	Complied

Note: UL Japan, Inc.'s EMI Work Procedures No. QPM05 and QPM15.

* In case any questions arise about test procedure, ANSI C63.4: 2003 is also referred.

FCC 15.31 (e)

The RF Module has its own regulator.

The RF Module is constantly provided voltage (DC3.3V) through its own regulator regardless of input voltage. Therefore, this EUT complies with the requirement.

FCC Part 15.203 / 212 Antenna requirement

It is impossible for end users to replace the antenna, because the antenna is mounted inside of the specific host device in which the EUT is installed. Therefore, the equipment complies with the antenna requirement of Section 15.203 / 212.

3.3 Addition to standard

Item	Test Procedure	Specification	Worst margin	Results	Remarks
99% Occupied Bandwidth	IC: RSS-Gen 4.6.1	IC: RSS-Gen 4.6.1	N/A	N/A	Conducted

Other than above, no addition, exclusion nor deviation has been made from the standard.

UL Japan, Inc.

Head Office EMC Lab.

4383-326 Asama-cho, Ise-shi, Mie-ken 516-0021 JAPAN

Telephone : +81 596 24 8116

Facsimile : +81 596 24 8124

3.4 Uncertainty

EMI

The following uncertainties have been calculated to provide a confidence level of 95% using a coverage factor k=2.

Test room (semi-anechoic chamber)	Conducted emission (±dB)
	150kHz-30MHz
No.1	2.6dB
No.2	2.9dB
No.3	3.3dB
No.4	2.8dB

Test room (semi-anechoic chamber)	Radiated emission (10m*)(±dB)		
	9kHz -30MHz	30MHz -300MHz	300MHz -1GHz
No.1	2.7dB	4.8dB	5.0dB
No.2	-	-	-
No.3	-	-	-
No.4	-	-	-

*10m = Measurement distance

Test room (semi-anechoic chamber)	Radiated emission						
	(3m*)(±dB)				(1m*)(±dB)		(0.5m*)(±dB)
	9kHz -30MHz	30MHz -300MHz	300MHz -1GHz	1GHz -10GHz	10GHz -18GHz	18GHz -26.5GHz	26.5GHz -40GHz
No.1	2.9dB	4.8dB	5.0dB	3.9dB	4.3dB	4.5dB	4.3dB
No.2	3.5dB	4.8dB	5.1dB	4.0dB	4.2dB	4.4dB	4.2dB
No.3	3.8dB	4.6dB	4.7dB	4.0dB	4.2dB	4.5dB	4.2dB
No.4	3.5dB	4.4dB	4.9dB	4.0dB	4.2dB	4.6dB	4.2dB

*3m/1m/0.5m = Measurement distance

Power meter (±dB)	
Below 1GHz	Above 1GHz
1.0dB	1.0dB

Antenna terminal conducted emission and Power density (±dB)			Antenna terminal conducted emission (±dB)		Channel power (±dB)
Below 1GHz	1GHz-3GHz	3GHz-18GHz	18GHz-26.5GHz	26.5GHz-40GHz	
1.0dB	1.1dB	2.7dB	3.2dB	3.3dB	1.5dB

Conducted Emission test

The data listed in this test report has enough margin, more than the site margin.

Radiated emission test(3m)

The data listed in this test report has enough margin, more than the site margin.

UL Japan, Inc.

Head Office EMC Lab.

4383-326 Asama-cho, Ise-shi, Mie-ken 516-0021 JAPAN

Telephone : +81 596 24 8116

Facsimile : +81 596 24 8124

3.5 Test Location

UL Japan, Inc. Head Office EMC Lab. *NVLAP Lab. code: 200572-0
4383-326 Asama-cho, Ise-shi, Mie-ken 516-0021 JAPAN
Telephone : +81 596 24 8116 Facsimile : +81 596 24 8124

	FCC Registration Number	IC Registration Number	Width x Depth x Height (m)	Size of reference ground plane (m) / horizontal conducting plane	Other rooms
No.1 semi-anechoic chamber	313583	2973C-1	19.2 x 11.2 x 7.7m	7.0 x 6.0m	No.1 Power source room
No.2 semi-anechoic chamber	655103	2973C-2	7.5 x 5.8 x 5.2m	4.0 x 4.0m	-
No.3 semi-anechoic chamber	148738	2973C-3	12.0 x 8.5 x 5.9m	6.8 x 5.75m	No.3 Preparation room
No.3 shielded room	-	-	4.0 x 6.0 x 2.7m	N/A	-
No.4 semi-anechoic chamber	134570	2973C-4	12.0 x 8.5 x 5.9m	6.8 x 5.75m	No.4 Preparation room
No.4 shielded room	-	-	4.0 x 6.0 x 2.7m	N/A	-
No.5 semi-anechoic chamber	-	-	6.0 x 6.0 x 3.9m	6.0 x 6.0m	-
No.6 shielded room	-	-	4.0 x 4.5 x 2.7m	4.75 x 5.4 m	-
No.6 measurement room	-	-	4.75 x 5.4 x 3.0m	4.75 x 4.15 m	-
No.7 shielded room	-	-	4.7 x 7.5 x 2.7m	4.7 x 7.5m	-
No.8 measurement room	-	-	3.1 x 5.0 x 2.7m	N/A	-
No.9 measurement room	-	-	8.0 x 4.5 x 2.8m	2.0 x 2.0m	-
No.10 measurement room	-	-	2.6 x 2.8 x 2.5m	2.4 x 2.4m	-
No.11 measurement room	-	-	3.1 x 3.4 x 3.0m	2.4 x 3.4m	-

* Size of vertical conducting plane (for Conducted Emission test) : 2.0 x 2.0m for No.1, No.2, No.3, and No.4 semi-anechoic chambers and No.3 and No.4 shielded rooms.

3.6 Test set up, Data of EMI, and Test instruments

Refer to APPENDIX.

SECTION 4: Operation of E.U.T. during testing

4.1 Operating Mode(s)

Bluetooth (BT): Transmitting (Tx), Payload: PRBS9
Receiving (Rx)
Inquiry

Details of Operating Mode(s)

Test Item	Mode	Tested frequency
Conducted Emission, Spurious Emission (Conducted/Radiated)	Tx (Hopping off) DH5, 3DH5	2402MHz 2441MHz 2480MHz
	Rx	2441MHz
Carrier Frequency Separation	Tx (Hopping on) DH5, 3DH5 Inquiry	2402MHz 2441MHz 2480MHz
20dB Bandwidth Maximum Peak Output Power	Tx (Hopping off) DH5, 3DH5 Inquiry	2402MHz 2441MHz 2480MHz
Number of Hopping Frequency	Tx (Hopping on) DH5, 3DH5 Inquiry	-
Dwell time	Tx (Hopping on), -DH1, DH3, DH5 -3DH1, 3DH3, 3DH5 Inquiry	-
Band Edge Compliance (Conducted)	Tx DH5, 3DH5 -Hopping on -Hopping off	2402MHz 2480MHz
99% Occupied Bandwidth	Tx DH5, 3DH5 -Hopping on -Hopping off	2402MHz 2441MHz 2480MHz
<p>*As a result of preliminary test, the formal test was performed with the above modes, which had the maximum payload length (except Dwell time test) The test was not performed at AFH mode, because the decrease of number of channel (min: 20ch) at AFH mode does not influence on the output power and bandwidth of the EUT.</p> <p>*EUT has the power settings by the software as follows; Power settings: BDR(DH5): 40 EDR(2DH5/3DH5): 45 Software: BV3E_firmware Version 1.0 *This setting of software is the worst case. Any conditions under the normal use do not exceed the condition of setting. In addition, end users cannot change the settings of the output power of the product.</p>		

* Information of the representative host device

Type of Equipment : Digital Camera
Model No. : G700SE
Serial No. : 1101 *1)
: 1190 *2)
: No.1 *3)
: No.4 *4)
Operating voltage : DC3.8V (AC Adapter)
: DC3.6V (Lithium-ion Battery Pack)

- *1) For Conducted emission, Radiated emission (Below 1GHz) test only
*2) For Radiated emission (Above 1GHz) test
*3) For Power Density test only
*4) For Antenna Terminal Conducted test except for Power Density test

UL Japan, Inc.

Head Office EMC Lab.

4383-326 Asama-cho, Ise-shi, Mie-ken 516-0021 JAPAN

Telephone : +81 596 24 8116

Facsimile : +81 596 24 8124

4.2 Configuration and peripherals

<For Conducted emission, Radiated emission tests>

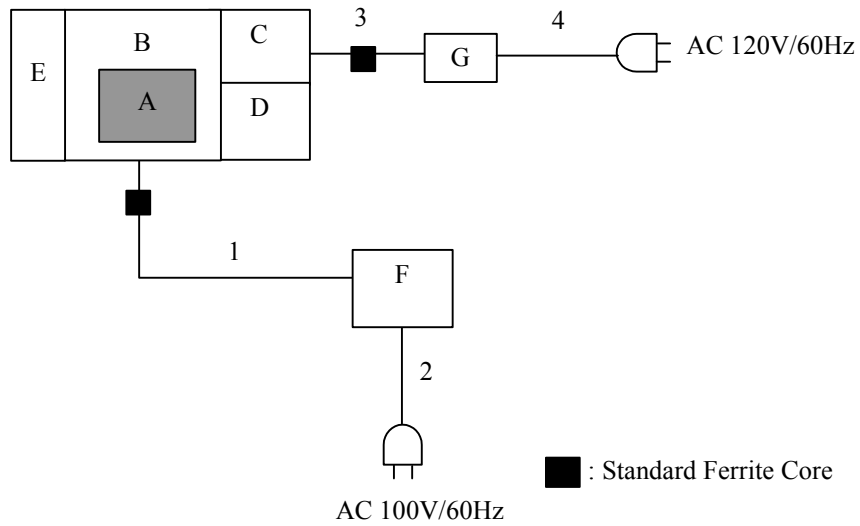

<For Antenna Terminal Conducted test>

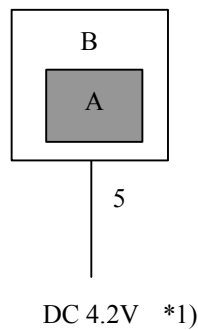

*1) DC/DC converter output voltage of Digital Camera (G700SE)

* Cabling and setup(s) were taken into consideration and test data was taken under worse case conditions.

Description of EUT and Support equipment

No.	Item	Model number	Serial number	Manufacturer	Remarks
A	Module Circuit Board	SG4G2-TB3	No.65 *1) No.55 *2) No.1 *3) No.4 *4)	SANYO Electric Co., Ltd.	EUT
B	Digital Camera	G700SE	1101 *5) 1190 *6) No.1 *3) No.4 *4)	Ricoh Company, Ltd.	*7)
C	AC Adapter Converter	CN-7	-	Ricoh Company, Ltd.	*8)
D	SD Card	RP-SD256B	BJ8CA308934	Panasonic Corporation	-
E	GPS	GP-1	1078	Ricoh Company, Ltd.	-
F	Display	LL-T1530A	1A051790	Sharp Corporation	-
G	AC Adapter	AC-5	45	Ricoh Company, Ltd.	*8)

*1) For Conducted emission, Radiated emission (Below 1GHz) tests

*2) For Radiated emission (Above 1GHz) test only

*3) For Power Density test only

*4) For Antenna Terminal Conducted test except for Power Density test

*5) For Conducted emission, Radiated emission (Below 1GHz) test only

*6) For Radiated emission (Above 1GHz) test

*7) The test was performed with USB port of opened state since the wireless operation was not performed in the state using USB port.

*8) AC Adapter was used for AC activating.

List of cables used

No.	Name	Length (m)	Shield		Remarks
			Cable	Connector	
1	AV Cable	1.1	Shielded	Shielded	-
2	AC Cable	1.7	Unshielded	Unshielded	-
3	DC Cable	1.7	Shielded	Shielded	*1)
4	AC Cable	1.2	Unshielded	Unshielded	-
5	DC Cable	1.7	Unshielded	Unshielded	-

*1) It was confirmed that a standard ferrite core of AC Adapter (AC-5) did not influence the test result.

UL Japan, Inc.

Head Office EMC Lab.

4383-326 Asama-cho, Ise-shi, Mie-ken 516-0021 JAPAN

Telephone : +81 596 24 8116

Facsimile : +81 596 24 8124

SECTION 5: Conducted Emission

Test Procedure and conditions

EUT was placed on a urethane platform of nominal size, 0.5m by 1.0m, raised 0.8m above the conducting ground plane.

The rear of tabletop was located 40cm to the vertical conducting plane. The rear of EUT, including peripherals aligned and flushed with rear of tabletop. All other surfaces of tabletop were at least 80cm from any other grounded conducting surface. EUT was located 80cm from a Line Impedance Stabilization Network (LISN)/ Artificial mains Network (AMN) and excess AC cable was bundled in center.

For the tests on EUT with other peripherals (as a whole system)

I/O cables that were connected to the peripherals were bundled in center. They were folded back and forth forming a bundle 30cm to 40cm long and were hanged at a 40cm height to the ground plane. All unused 50ohm connectors of the LISN(AMN) were resistivity terminated in 50ohm when not connected to the measuring equipment.

The AC Mains Terminal Continuous disturbance Voltage has been measured with the EUT in a Semi Anechoic Chamber .

The EUT was connected to a LISN (AMN).

An overview sweep with peak detection has been performed.

The test results and limit are rounded off to one decimal place, so some differences might be observed.

Detector : QP and AV
Measurement range : 0.15-30MHz
Test data : APPENDIX
Test result : Pass

UL Japan, Inc.

Head Office EMC Lab.

4383-326 Asama-cho, Ise-shi, Mie-ken 516-0021 JAPAN

Telephone : +81 596 24 8116

Facsimile : +81 596 24 8124

SECTION 6: Radiated Spurious Emission

Test Procedure

EUT was placed on a urethane platform of nominal size, 0.5m by 1.0m, raised 0.8m above the conducting ground plane.

The Radiated Electric Field Strength has been measured in a Semi Anechoic Chamber with a ground plane.

The height of the measuring antenna varied between 1 and 4m and EUT was rotated a full revolution in order to obtain the maximum value of the electric field strength.

The measurements were performed for both vertical and horizontal antenna polarization with the Test Receiver, or the Spectrum Analyzer.

The measurements were made with the following detector function of the test receiver and the Spectrum analyzer (in linear mode).

The test was made with the detector (RBW/VBW) in the following table.

When using Spectrum analyzer, the test was made with adjusting span to zero by using peak hold.

Test Antennas are used as below;

Frequency	Below 30MHz	30MHz to 300MHz	300MHz to 1GHz	Above 1GHz
Antenna Type	Loop	Biconical	Logperiodic	Horn

In any 100kHz bandwidth outside the restricted band in which the spread spectrum intentional radiator is operating, the radio frequency power that is produced by the intentional radiator confirmed 20dB below that in the 100kHz bandwidth within the band that contains the highest level of the desired power, based on a radiated measurement.

20dBc was applied to the frequency over the limit of FCC 15.209 / Table 2 of RSS-210 2.7 (IC) and outside the restricted band of FCC15.205 / Table 1 of RSS-210 2.7 (IC).

Frequency	Below 1GHz	Above 1GHz		20dBc
Instrument used	Test Receiver	Spectrum Analyzer		Spectrum Analyzer
Detector	QP	PK	AV	PK
IF Bandwidth	BW 120kHz(T/R)	RBW: 1MHz VBW: 3MHz	RBW: 1MHz VBW: 10Hz or RBW: 1MHz VBW: 270Hz *1)	RBW: 100kHz VBW: 300kHz (S/A)
Test Distance	3m	3m (below 10GHz) 1m *2) (above 10GHz)		3m (below 10GHz) 1m (above 10GHz)

*1) Used for the band edge of the carrier and the harmonics that can be measured. The VBW is based on the inverse of the duty cycle (see Appendix).

*2) Distance Factor: $20 \times \log(3.0\text{m}/1.0\text{m}) = 9.5\text{dB}$

- The carrier level and noise levels were confirmed at each position of X, Y and Z axes of EUT to see the position of maximum noise, and the test was made at the position that has the maximum noise.

The test results and limit are rounded off to one decimal place, so some differences might be observed.

Measurement range : 30M-25GHz
Test data : APPENDIX
Test result : Pass

UL Japan, Inc.

Head Office EMC Lab.

4383-326 Asama-cho, Ise-shi, Mie-ken 516-0021 JAPAN

Telephone : +81 596 24 8116

Facsimile : +81 596 24 8124

SECTION 7: Antenna Terminal Conducted Tests

Test Procedure

The tests were made with below setting connected to the antenna port.

Test	Span	RBW	VBW	Sweep time	Detector	Trace	Instrument used
20dB Bandwidth	3MHz	30kHz	100kHz	Auto	Peak	Max Hold	Spectrum Analyzer
99% Occupied Bandwidth	Enough width to display 20dB Bandwidth	1 to 3% of Span	Three times of RBW	Auto	Peak	Max Hold	Spectrum Analyzer
Maximum Peak Output Power	-	-	-	Auto	Peak	-	Power Meter (Sensor: 50MHz BW)
Carrier Frequency Separation	3MHz or 5MHz	100kHz or 30kHz	300kHz or 100kHz	Auto	Peak	Max Hold	Spectrum Analyzer
Number of Hopping Frequency	30MHz	300kHz	1MHz	Auto	Peak	Max Hold	Spectrum Analyzer
Dwell Time	Zero Span	1MHz	3MHz	As necessary capture the entire dwell time per hopping channel	Peak	Max Hold	Spectrum Analyzer
Conducted Spurious Emission	Less or equal to 5GHz (Range: 30MHz-25GHz)	100kHz	300kHz	Auto	Peak	Max Hold	Spectrum Analyzer

The test results and limit are rounded off to two decimals place, so some differences might be observed.

Test data : APPENDIX
Test result : Pass