

DataPlug



Model DP2.2-488

Rev.04

TEXA

SUMMARY

1	Revision of the Manual.....	3
	INTRODUCTION.....	4
2	LEGEND OF THE SYMBOLS USED.....	5
3	SAFETY RULES	7
3.1	Glossary.....	7
3.2	General Rules.....	7
3.3	Operator Safety.....	8
3.4	Vehicle Safety.....	8
3.5	Device Safety.....	10
4	ENVIRONMENTAL INFORMATION.....	12
5	OPERATION OF THE RADIO DEVICES.....	13
6	REGULATORY INFORMATION.....	14
7	DataPlug.....	19
8	DESCRIPTION.....	20
9	TECHNICAL FEATURES	21
10	LOCATION OF THE DIAGNOSTIC SOCKET.....	23
11	INSTALLATION AND CONFIGURATION.....	24
11.1	Installation.....	24
11.2	Configuration.....	26
11.2.1	Display unit's Bluetooth not active.....	26
11.2.2	Display unit's Bluetooth active.....	26
12	USE.....	27
13	POWER SUPPLY	28
14	BLINK CODES.....	29
15	MAINTENANCE.....	30
16	TROUBLESHOOTING.....	31

DATA_{PLUG} TECHNICAL MANUAL

1 Revision of the Manual

This document is the technical manual for the product: DataPlug

Document Review Number: 04

Date of Issue: 31/01/2023

INTRODUCTION

Dear Customer,

We would like to thank you for choosing a TEXA product for your workshop.

We are certain that you will get the greatest satisfaction from it and receive a great deal of help in your work.

Please read through the instructions in this manual carefully and keep it for future reference.

Reading and understanding the following manual will help you to avoid damage or personal injury caused by improper use of the product.

TEXA S.p.A reserves the right to make any changes deemed necessary to improve the manual for any technical or marketing requirement; the company may do so at any time without prior notice.

This product is intended to be used exclusively by technicians specialised in the Automotive industry. Reading and understanding the information in this manual cannot replace adequate specialised training in this field.

The sole purpose of the manual is to illustrate the functioning of the product sold. It is not intended to offer technical training of any kind and technicians will therefore carry out any interventions under their own responsibility and will be accountable for any damage or personal injury caused by negligence, carelessness, or inexperience, regardless of the fact that a TEXA S.p.A. tool has been used following the information contained in this manual.

Any additions to this manual, useful in describing the new versions of the program and the new functions associated to it, may be sent to you through our TEXA technical bulletin service.

This manual is to be considered an essential part of the product to which it refers. If it is resold, the original buyer is therefore required to forward the manual to the new owner.













Reproduction, partial or whole, of this manual in any form without written authorisation by the manufacturer is strictly forbidden.



The original manual was written in Italian, every other language is a translation of the original manual.

© **copyright and database rights 2015.** The material contained in this document is protected by the copyright and database rights. All rights reserved according to Law and international agreements.

2 LEGEND OF THE SYMBOLS USED

Some of the symbols indicated below may not be used in the manual.

	Toxic material hazard		Laser beam hazard
	Explosive material hazard		Low temperature danger - freezing
	Electric shock hazard		General Risk
	Electromagnetic field hazard		Obligation to read the instructions
	Flammable material hazard		Safety glasses required
	Hot surface hazard		Protective gloves required
	Corrosive substance hazard		Protective clothing required
	Risk of noise level above 80 dB(A)		Respiratory protection required
	Moving Parts Risk		Disconnect mains plug from electrical outlet
	Risk of crushing hands		Do not wet the device
	Floor level obstacle warning		

	This is not a safety symbol. It indicates a hazardous situation which, if not avoided, will result in serious permanent injury or death.
	This is not a safety symbol. It indicates a hazardous situation which, if not avoided, may result in serious permanent injury or death.
	This is not a safety symbol. It indicates a hazardous situation which, if not avoided, may result in minor injury.

NOTICE	This is not a safety symbol. It indicates a hazardous situation which, if not avoided, may result in material damage.
INFORMATION	This is not a safety symbol. It indicates important information.

3 SAFETY RULES

The technology used for the design and manufacturing control of **DataPlug** makes it a reliable, simple and safe device to use.

The personnel in charge is required to follow the general safety rules, use the DATAPLUG device for its intended use only and carry out the maintenance properly as described in this manual.

3.1 Glossary

Operator: qualified person responsible for installing the diagnostic device.

Device: any **DataPlug** device.

Coverage list: the official document that indicates only the vehicles on which you can safely install the device.

Pairing: the mutual recognition process that takes place when two Bluetooth devices establish communication with one another for the first time. It could require entering an identification code (PIN).

Diagnostic socket / OBD socket: vehicle connector that allows connecting to the vehicle's control unit.

Display unit: any smartphone in which the App that allows connecting with **DataPlug** is installed

3.2 General Rules



The operator must carefully read and understand the information and instructions in the technical documents provided with the device.

If the operator is not able to read this manual, the operating instructions and safety indications must be read and discussed in the operator's native language.

- *The operator that works on vehicles must have basic qualifications and knowledge of mechanics, automotive engineering, vehicle repair, and of the potential dangers that may arise during the vehicle maintenance operations.*
- *The operator must carefully read and understand the information and the instructions in the technical documents provided with the device.*
- *The operator must carefully follow all the instructions provided in the technical documents.*
- *The operator must be completely clear-headed and sober and not take drugs nor drink alcohol before or when using the device.*
- *The operator is required to wear adequate personal protective equipment (PPE) at all times when using the device.*
- *If the power cable is damaged, it must be replaced by the manufacturer, its technical assistance service or similar qualified person, so as to prevent any risks.*
- *The operator is prohibited from carrying out ANY OPERATION NOT EXPRESSLY REQUESTED AND INDICATED.*

3.3 Operator Safety

WARNING



Installing the device requires connecting it to the diagnostic socket and within the passenger compartment.

Make sure you operate in absolute safety and using the appropriate protective equipment.

Safety Measures:

- *In order to avoid injuring people and/or damaging the device or the electronic systems of the vehicle connected to the device, do not allow unqualified personnel to use the device.*

CAUTION



The device was designed and created in order to allow an easy, fast and safe installation; nevertheless, it is impossible to completely eliminate some of the risks connected to this operation.

Safety Measures:

- *Make sure the vehicle's instrument panel is off before starting the installation.*
- *Make sure the vehicle on which you wish to install the device is on a flat surface and with the parking brake engaged.*
- *Make sure there are not any damaged cables around the diagnostic socket.*
- *Be careful not to injure yourself on sharp plastic edges or metal plates around the diagnostic socket.*

CAUTION



The position in which the device is placed and the behaviour of its LEDs were designed to avoid any possible obstacle or interference for the driver.

Lack of concentration while driving puts both the driver and the vehicle in danger.

Safety Measures:

- *Do not drive the vehicle before reassembling the plastic parts and panels previously removed.*
- *Do not get distracted by checking the status of the device or interacting with it neither directly or through the display unit.*

3.4 Vehicle Safety

CAUTION



The device was designed and created in order to allow an easy, fast and safe installation; nevertheless, it is best to be sure not to compromise any vehicle function during this operation.

Safety Measures:

- *Delicately remove any plastic part, cover or bulkhead that might cover the diagnostic socket, being careful not to loose any screw or fastening hook.*
- *Be careful not to damage or disconnect any plastic part or cable near the diagnostic cable.*
- *Carefully reposition and close any plastic part, cover or bulkhead once the device's installation and configuration phase is completed.*
- *Connect the device properly and securely in order to avoid it from accidentally disconnecting during use.*
- *Do not install the device on vehicles that are not supported.*

3.5 Device Safety

WARNING



If the device gets wet or damaged, or comes into contact with liquids, this may cause short circuits, fire, material damage or serious injury.

Never use a wet or damaged device.

CAUTION



The device was designed to be used in specific environmental conditions.

Using the device in environments with temperatures and humidity that differ from those specified may impair its efficiency.

Safety Measures:

- *Always place the device in a dry area.*
- *Do not expose the device to rain or water jets.*
- *Do not expose or use the device close to heat sources.*
- *Position the device in order to guarantee its proper ventilation.*
- *Do not use corrosive chemicals, solvents or harsh detergents to clean the device.*

CAUTION



The device was created to be mechanically resistant and suitable for the use it was designed for.

Careless use and excessive mechanical strain may impair its efficiency.

Safety Measures:

- *Do not drop, shake or knock the device.*
- *Do not carry out any type of intervention that may damage the device.*
- *Do not open or disassemble the device.*
- *Make sure not to damage the diagnostic connectors when connecting and disconnecting the device.*
- *Do not force the device or the connectors and take the utmost care during all connecting and disconnecting operations.*
- *Do not use screwdrivers or other tools to lever and disconnect the device.*

NOTICE



The device was manufactured to be electrically safe and to work with specific supply voltage levels.

Failure to comply with the specifications related to the power supply may impair the device's efficiency.

Safety Measures:

- *If not specified otherwise, use the device on vehicles with a 12/24 Vdc power supply and chassis connected to the negative pole.*
- *Use the device on supported vehicles only.*
- *Do not use external batteries to power the device.*
- *Adopt the necessary measures to avoid electrostatic discharges which may damage the device.*

NOTICE



The electromagnetic compatibility tests carried out on the device guarantee that it can be adapted to the technologies normally used on vehicles (e.g. engine control, ABS, airbag, etc.). Nevertheless, if malfunctions occur, contact the vehicle's dealer.

4 ENVIRONMENTAL INFORMATION



Do not dispose of this product with other undifferentiated solid waste.
For information regarding the disposal of this product please see the pamphlet supplied.

5 OPERATION OF THE RADIO DEVICES

Wireless connection with Bluetooth® technology

The wireless connection with Bluetooth technology is a technology that supplies a standard and reliable method to exchange information between different devices, using radio waves. Products such as cellular phones, portable devices, computers, printers, cameras, pocket PCs etc. use this type of technology.

The Bluetooth interface searches for compatible electronic devices according to the radio signal they generate and establishes a connection between them. The tools operate a selection suggesting only compatible / enabled devices. This does not exclude the presence of other sources of communication or interference.



THE EFFICIENCY AND THE QUALITY OF THE BLUETOOTH COMMUNICATION MAY BE INFLUENCED BY THE PRESENCE OF RADIO DISTURBANCE SOURCES. THE COMMUNICATION PROTOCOL HAS BEEN DEVELOPED TO MANAGE THESE TYPES OF ERRORS; HOWEVER, IN THESE CASES COMMUNICATION MAY BECOME DIFFICULT AND CONNECTION MAY REQUIRE SEVERAL ATTEMPTS.

SHOULD THE WIRELESS CONNECTION ENCOUNTER SERIOUS PROBLEMS THAT MAY COMPROMISE A REGULAR COMMUNICATION, THE SOURCE OF THE ENVIRONMENTAL ELECTROMAGNETIC INTERFERENCE MUST BE IDENTIFIED AND ITS INTENSITY REDUCED.

Position the product in order to guarantee the correct operation of its radio devices. In particular, do not cover it with any shielding or metal materials in general.

6 REGULATORY INFORMATION

Simplified EU Declaration of Conformity

	<p>The manufacturer, TEXA S.p.A., declares that the DataPlug radio equipment type is compliant with the following directives:</p> <ul style="list-style-type: none">• RED 2014/53/EU <p>The complete text of the EU declaration of conformity is available at the following Internet address: http://www.texa.it/download.</p>
	<p>The manufacturer, TEXA S.p.A., declares that the DataPlug radio equipment type is compliant with the following directives:</p> <ul style="list-style-type: none">• Radio Equipment Regulation 2017 (2016 n. 1206) <p>The complete text of the UKCA declaration of conformity is available at the following Internet address: http://www.texa.com/download.</p>

Use restrictions and warnings (FCC / ISED)

Modification statement

Changes or modifications not expressly approved by the party responsible for compliance could void the user's authority to operate the equipment.

Les changements ou modifications non expressément approuvés par la partie responsable de la conformité peuvent annuler le droit de l'utilisateur à utiliser l'équipement.

Labeling information

Device model: **DP2.2-488**

- *FCC ID: T8RDP22*
- *IC: 23618-DP22*

FCC Compliance

This device complies with part 15 of the FCC Rules. Operation is subject to the following two conditions: (1) This device may not cause harmful interference, and (2) this device must accept any interference received, including interference that may cause undesired operation.

This equipment has been tested and found to comply with the limits for a Class B digital device, pursuant to part 15 of the FCC Rules. These limits are designed to provide reasonable protection against harmful interference in a residential installation.

This equipment generates, uses and can radiate radio frequency energy and, if not installed and used in accordance with the instructions, may cause harmful interference to radio communications. However, there is no guarantee that interference will not occur in a particular installation. If this equipment does cause harmful interference to radio or television reception, which can be determined by turning the equipment off and on, the user is encouraged to try to correct the interference by one or more of the following measures:

- *Reorient or relocate the receiving antenna.*
- *Increase the separation between the equipment and receiver.*
- *Connect the equipment into an outlet on a circuit different from that to which the receiver is connected.*
- *Consult the dealer or an experienced radio/TV technician for help.*

Cet appareil est conforme à la partie 15 des règlements de la FCC. L'utilisation est soumise aux deux conditions suivantes: (1) l'appareil ne doit pas produire de brouillage, et (2) l'appareil doit accepter tout brouillage radioélectrique subi, même si le brouillage est susceptible d'en compromettre le fonctionnement.

Remarque: Cet équipement a été testé et déclaré conforme aux limites d'un appareil numérique de classe B, conformément à la partie 15 des règlements de la FCC. Ces limites sont conçues pour fournir une protection raisonnable contre les interférences nuisibles dans une installation résidentielle.

Ce produit génère, utilise et peut émettre des ondes radio qui peuvent causer des interférences nuisibles s'il n'est pas installé et utilisé conformément aux instructions. Si néanmoins ce produit cause des interférences nuisibles à la réception de la radio ou de la télévision, ce qui peut être déterminé en éteignant et en rallumant l'appareil, l'utilisateur est encouragé à essayer de corriger l'interférence par une ou plusieurs des mesures suivantes:

- *Réorienter ou déplacer l'antenne de réception.*
- *Augmenter la distance entre le produit et le récepteur.*
- *Brancher l'appareil sur une prise de courant différente de celle à laquelle le récepteur est raccordé.*
- *Consulter le revendeur ou un technicien radio/TV expérimenté pour obtenir de l'aide.*

ISED compliance

This device contains license-exempt transmitter(s)/receiver(s) that comply with Innovation, Science and Economic Development Canada's license exempt RSS(s). Operation is subject to the following two conditions: (1) This device may not cause interference. (2) This device must accept any interference, including interference that may cause undesired operation of the device.

This radio transmitter has been approved by Innovation, Science and Economic Development Canada to operate with the antenna types listed below, with the maximum permissible gain indicated. Antenna types not included in this list that have a gain greater than the maximum gain indicated for any type listed are strictly prohibited for use with this device.

L'émetteur/recepteur exempt de licence contenu dans le present appareil est conforme aux CNR d'Innovation, Sciences et Développement économique Canada applicables aux appareils radio exempts de licence. L'exploitation est autorisée aux deux conditions suivantes : (1) L'appareil ne doit pas produire de brouillage; (2) L'appareil doit accepter tout brouillage radioélectrique subi, même si le brouillage est susceptible d'en compromettre le fonctionnement.

Le présent émetteur radio a été approuvé par Innovation, Sciences et Développement économique Canada pour fonctionner avec les types d'antenne énumérés ci dessous et ayant un gain admissible maximal. Les types d'antenne non inclus dans cette liste, et dont le gain est supérieur au gain maximal indiqué pour tout type figurant sur la liste, sont strictement interdits pour l'exploitation de l'émetteur.

ICES-003 Class B Notice -Avis NMB-003 Classe B: This Class B digital device complies with Canadian ICES-003

Cet appareil numérique classe B est conforme à la norme Canadien NMB-003. CAN ICES-3(B) / NMB-3(B)

RF Radiation Exposure statement

This product complies with FCC and ISED radiation exposure limits set forth for an uncontrolled environment. The antenna should be installed and operated with minimum distance of 20 cm between the radiator and your body.

This device complies with Health Canada's Safety Code. The installer of this device should ensure that RF radiation is not emitted in excess of the Health Canada's requirement.

Cet appareil est conforme aux limites d'exposition aux rayonnements de l'ISED pour un environnement non contrôlé. L'antenne doit être installée de façon à garder une distance minimale de 20 centimètres entre la source de rayonnements et votre corps.

Cet appareil est conforme avec Santé Canada Code de sécurité 6. Le programme d'installation de cet appareil doit s'assurer que les rayonnements RF n'est pas émis au-delà de l'exigence de Santé Canada.

Antennas List

This product has been certified with the following antennas:

- M310221 ceramic antennas, with a peak gain 1.7 dBi in frequency range 2400 ÷ 2485 MHz

Ce produit a été certifié avec les antennes suivantes:

- M310221 ceramic antennas, with a peak gain 1.7 dBi in frequency range 2400 ÷ 2485 MHz

Responsible party's contact located in Canada:

Company Name: Canadian Certification Consulting, Inc.
ISED Company No: 10842A
Contact Name: Jon Hughes, President
Street Address: 2210 Horizon Drive, Suite 17
City/Province/Zip: West Kelowna - BC V1Z 3L4 - Canada
Phone No: 1-250-575-1719
Email: info@can-cert.com

Responsible party's contact located in U.S.:

Company Name: TEXA USA Inc.
Contact Name: Fabio Mazzon, Technical Manager
Street Address: 409 Joyce Kilmer Ave - Suite 201
City/Province/Zip: New Brunswick, NJ 8901 - United States
Phone No: (732) 325-9336
Email: fabio.mazzon@texa.com
FRN: 0033570946

Certificação ANATEL

“Este produto está homologado pela ANATEL, de acordo com os procedimentos regulamentados pela Resolução 715/2019, e atende aos requisitos técnicos aplicados”. Para maiores informações, consulte o site da ANATEL www.anatel.gov.br



08257-23-10401

Este equipamento não tem direito à proteção contra interferência prejudicial e não pode causar interferência em sistemas devidamente autorizados.

7 DataPlug

DataPlug is a compact device that, during normal vehicle operation, can acquire information useful both to the driver and the mechanic.



The data acquired is useful to detect problems connected to the vehicle's management and its maintenance status.

The device can be installed on any Volkswagen vehicle that is in the specific coverage list.

The device must be connected to a specific diagnostic socket called **OBD socket**.

The device communicates with the vehicle's control unit through the OBD socket and acquires the required data.

The device is able to acquire the required data from the vehicle and to transmit it in real time via Bluetooth to the smartphone selected as a display unit.

For this to occur, a specific app must be installed in the display unit.

The app can be downloaded directly from Internet through



and



The acquired data is processed and displayed on the display unit.

Connecting and disconnecting the device from the vehicle is quick and easy.

Because of its small size, the device takes up little space and does not interfere with driving.

NOTICE

The device can also be used on vehicles with the **REESS** (Rechargeable Electrical Energy Storage System).

The system supplies power for the vehicle's electric drive.

8 DESCRIPTION

This chapter describes the general features of the device.

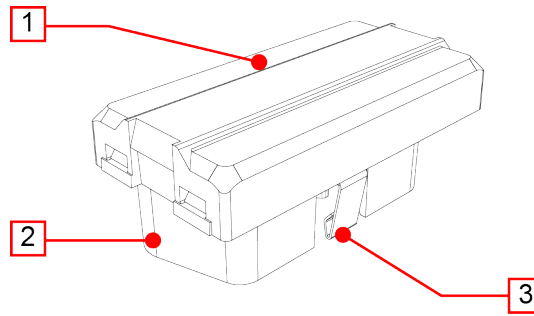

1. **Status LEDs:** *they give indications regarding the status of the device.**
 - **Green:** *indicates the status of the device without Bluetooth communication.*
 - **Blue:** *indicates the status of the device with Bluetooth communication.*
 - **Red:** *indicates the presence of errors.*
2. **OBD connector:** *it allows the connection between the device and the vehicle's diagnostic socket and, through the latter, to the control unit.*
3. **Retention hook:** *it secures the device to the vehicle's diagnostic socket.*

(*) For more information consult the chapter **Blink Codes**.

9 TECHNICAL FEATURES

Product	Vehicle diagnostic system with Bluetooth connectivity
Model	DP2.2-488
Processor	ARM Cortex M4 CPU CPU Clock up to 168MHz Total Flash: 1024 Kbytes FLASH Total RAM: 196 Kbytes RAM
Diagnostic connector	ISO15031-03 OBD Plug
Communication	Bluetooth Classic (2.1) and 4.0 Low Energy (Smart Ready)
Supply voltage	6 V min, 16 V max
Current absorption	Standby current < 100 μ A Operating current < 80 mA
Supported protocols	CAN HS ISO 11898-2
Directives	RED 2014/53/EU RoHS 2011/65/EU
Product regulations	EN 301 489-1 EN 301 489-17 EN 300 328 EN 62368-1 ISO 7637-1 ISO 7637-2
Regulations	ECE/ONU R10
Operating temperature	- 20 °C ÷ 70 °C
Storage temperature	- 40 °C ÷ 85 °C
Relative humidity	10% ÷ 80% without condensate

Dimensions in [mm]

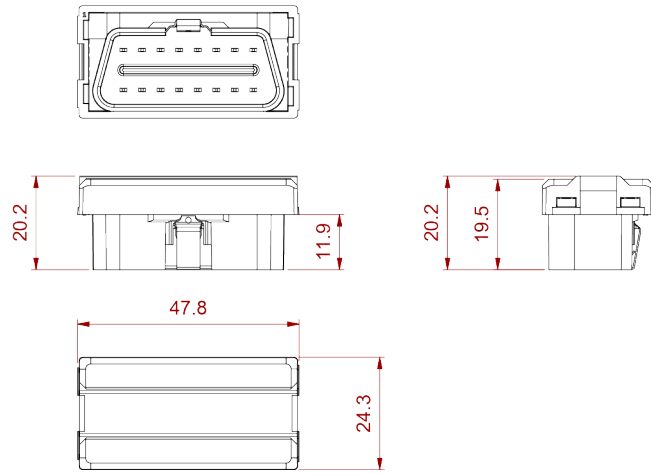

Weight

15 g

10 LOCATION OF THE DIAGNOSTIC SOCKET

The image below indicates where the diagnostic socket may be located.

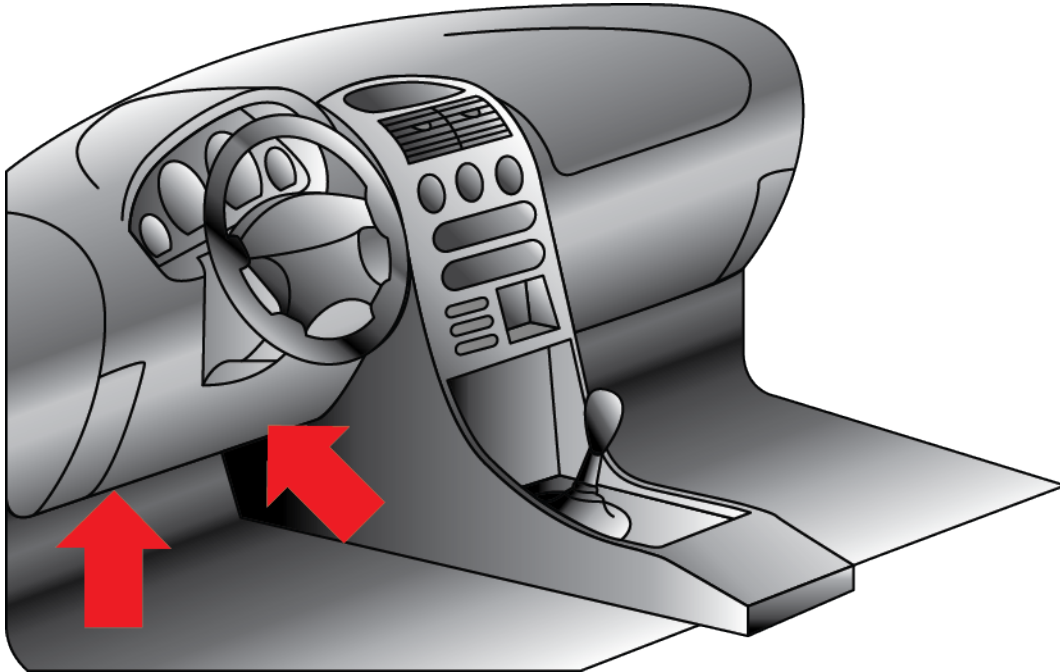

We always recommend you check the location of the OBD socket in the vehicle's user manual.

In case of doubts or for further information, contact the Technical Assistance or your Service Partner / Retailer.

11 INSTALLATION AND CONFIGURATION

The following paragraphs illustrate how to install and configure the device.

The device can be installed only on Volkswagen vehicles indicated in the specific coverage list.

CAUTION

Do not install the device on vehicles not expressly indicated in the specific coverage list.

11.1 Installation

INFORMATION

A screwdriver may be needed to loosen the fastening screws on the panels that cover the OBD socket.

Proceed as follows:

1. Turn off the vehicle (ignition key off).
2. Locate the OBD socket.
3. Carefully remove any panels cover the OBD socket.
4. Connect the device to the OBD socket.

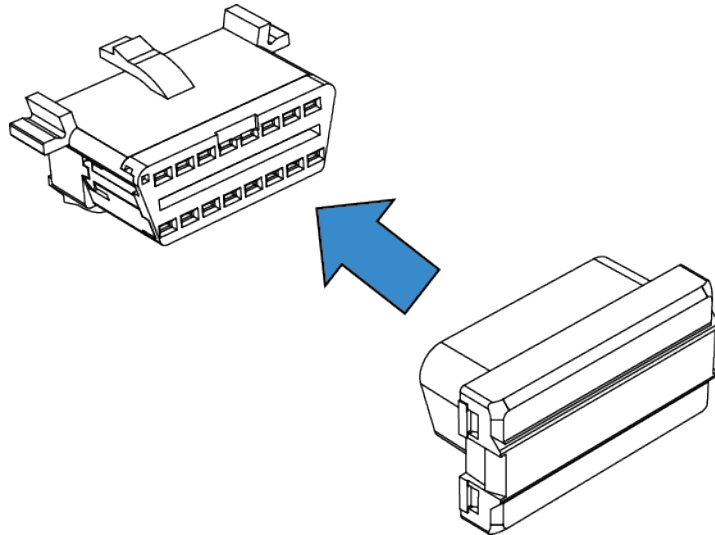

5. Turn on the vehicle (instrument panel on).
6. Make sure the device is securely connected to the diagnostic socket to avoid it from accidentally disconnecting during use.

CAUTION

Make sure that the various components around the diagnostic socket do not damage the device during installation.

CAUTION

Make sure that the position of the device does not interfere with driving.

The device might have to be disconnected from the OBD socket during vehicle maintenance operations in order to allow the connection of diagnostic devices.

In this case, use the **specific extractor tool**.

Proceed as follows:

1. Turn off the vehicle (ignition key off).
2. Carefully remove any panels cover the OBD socket.
3. Apply the extractor tool to the device.

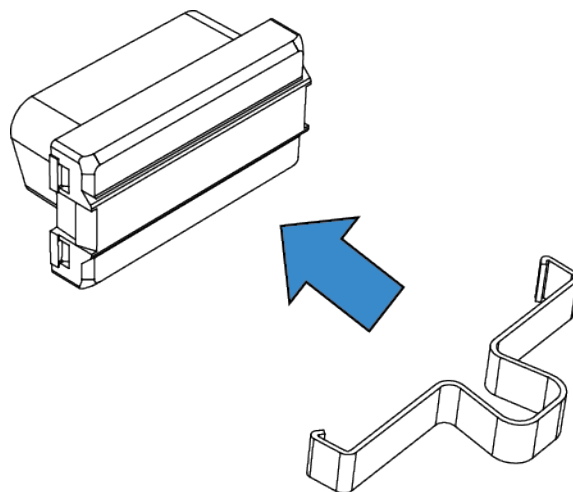

4. Carefully pull out the device until it disconnects completely from the diagnostic socket.

If you do not have the extractor tool, use your bare hands to carry out this operation.

NOTICE

Do not use screwdrivers or other tools to lever and disconnect the device.

11.2 Configuration

The configuration of the vehicle is completely automatic, nevertheless you should verify the connection to the control unit and to the display unit by means of the flashing LEDs before repositioning plastic parts or panels.

After the check, reposition all the plastic parts and panels previously removed.

CAUTION

Do not drive the vehicle before reassembling the plastic parts and panels previously removed.

11.2.1 Display unit's Bluetooth not active

Proceed as follows:

1. Turn on the vehicle's instrument panel.
2. Make sure the device's **green LED** goes through the following statuses:

Double flash	Configuration in progress.
Quick flash	Device configured, waiting to communicate with the vehicle.
Slow flash	Device configured and communicating with the vehicle. Normal operation.

At this point the device is ready for use.

11.2.2 Display unit's Bluetooth active

Proceed as follows:

1. Make sure the display unit's Bluetooth is active.
2. Turn on the vehicle's instrument panel.
3. Make sure the device's **green and blue LED** flashes alternately.
4. Launch the specific app for the connection to the device.
5. Start the procedure for the connection to the device.
6. Enter the PIN when requested by the app (the PIN is printed on the device's label and on a sticker applied to the product's box).
7. Make sure the device's **blue LED** goes through the following statuses:

Double flash	Configuration in progress.
Quick flash	Device configured, waiting to communicate with the vehicle.
Slow flash	Device configured and communicating with the vehicle. Normal operation.

At this point the device is ready for use.

For further information consult the Blink Codes chapter.

12 USE

It is no longer required to act directly on the device after the installation and configuration.

Any operation takes place through the display unit.

The device activates as soon as the vehicle's instrument panel is turned on and it connects automatically to the display unit if it is within the operating range of the device's Bluetooth antenna.

All the device's LEDs turn off automatically as soon as the vehicle starts moving.



WARNING

While driving, do not get distracted by checking the status of the device or interacting with it directly or using the display unit.

INFORMATION

In case of doubts or for further information, contact the Technical Assistance or your Service Partner / Retailer.

13 POWER SUPPLY

The device draws its power supply directly from the battery of the vehicle it is connected to through the OBD socket.

The vehicle's OBD socket is always powered, even when the engine and instrument panel are off.

The absorption never affects the battery's charge.

14 BLINK CODES

All the indicated statuses are to be intended with the **device connected to the diagnostic socket** and the **vehicle's instrument panel on**.

All the LEDs turn off as soon as the vehicle starts moving.

LED			Flash	Meaning
Green	Blue	Red		
X	X	-	Quick alternate flash	Device available for the pairing.
X	-	-	Double flash	BT communication not active. Configuration in progress.
			Quick flash	BT communication not active. Device configured, waiting to communicate with the vehicle.
			Slow flash	BT communication not active. Device configured and communicating with the vehicle. Normal operation.
-	X	-	Double flash	BT communication active. Configuration in progress.
			Quick flash	BT communication active. Device configured, waiting to communicate with the vehicle.
			Slow flash	BT communication active. Device configured and communicating with the vehicle. Normal operation.
X	-*	X	Orange flash	Update in progress.
-	-*	X	Flash	Error condition.

(*) The status of the blue LED is not relevant.

15 MAINTENANCE

This product does not require maintenance operations.

Follow the indications in this manual carefully in order to guarantee an extended use of the device.

In case of doubts or for further information, contact the Technical Assistance or your Service Partner / Retailer.

16 TROUBLESHOOTING

Below there are some situations / problems that can occur while using the device, along with a possible cause and a possible solution.

Situation / Problem	Possible Cause	Possible Solution
The device is connected to the diagnostic socket. The red LED flashes.	The vehicle is not in the list of vehicles on which the device can be used.	Use the device on a supported vehicle.
	There is an error condition.	Carefully disconnect and reconnect the device. If the error persists, contact the Technical Assistance service.
The device is connected to the vehicle's diagnostic socket but the green / blue LED does not turn on.	The vehicle's instrument panel is off.	Turn on the vehicle's instrument panel.
	The device is not properly connected and appears as switched off.	Carefully disconnect and reconnect the device to the diagnostic socket making sure it is inserted securely.
	The vehicle's diagnostic socket is damaged.	Contact an authorised workshop.
The pairing between the display unit and the device is not successful.	The PIN for the pairing of the device was not entered correctly when requested by the app.	Check and enter the PIN again when requested by the app.
	The maximum time limit for the pairing has been exceeded (2 minutes from key-on).	<ol style="list-style-type: none"> 1. Turn off the vehicle's instrument panel. 2. Turn on the vehicle's instrument panel. 3. Repeat the pairing procedure.
The display unit is not communicating with the device.	The vehicle's instrument panel is off.	Turn on the vehicle's instrument panel.
	The device is not properly connected and appears as switched off.	Carefully disconnect and reconnect the device to the diagnostic socket making sure it is inserted securely.
	The display unit's Bluetooth is not active.	Activate the display unit's Bluetooth.
	The display unit is not within the device's Bluetooth operating range.	Place the display unit within the device's operating range, that is inside the vehicle or in its immediate surroundings.
	Other wireless communications interfere with the signal.	Wait and try to communicate again. Eventually move the vehicle into another position.