

REVISIONS			
REV	DESCRIPTION	APP.	DATE
1	INITIAL RELEASE, CHANGED FCC & IC NUMBERS FOR T-ANTENNA	MFG	7/13/07
2	CORRECTED FCC & IC NUMBERS, UPDATED MODEL NUMBER	MAD	8/14/07

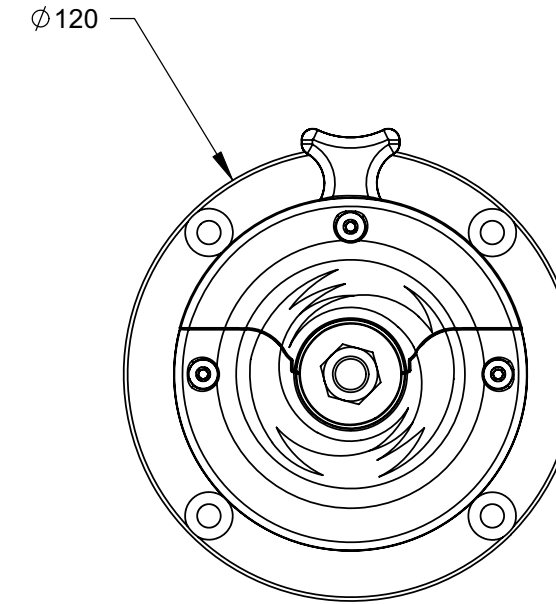
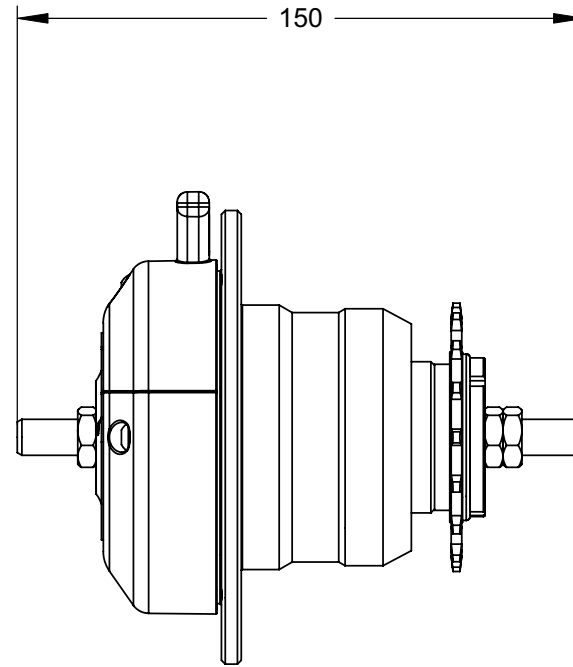
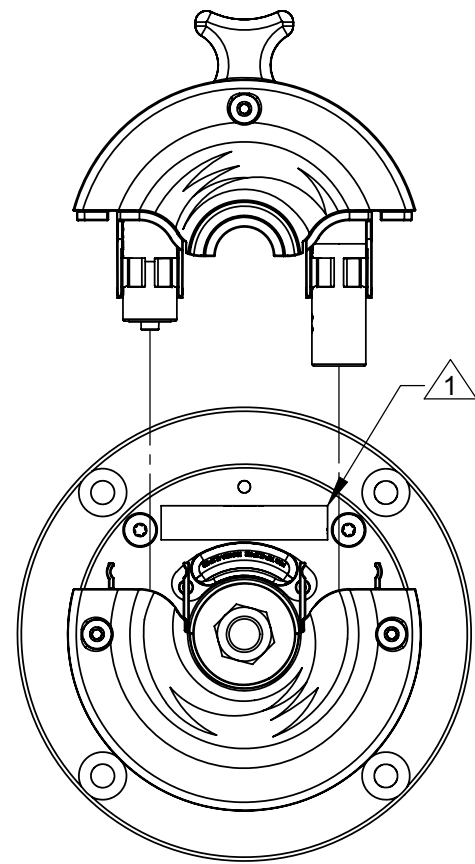

Saris Cycling Group, Inc.
 Model #: Pro 300PT-T
 Contains FCC ID: T8P-SL24TT1 IC: 6459A-SL24TT1

"This device complies with Industry Canada and Part 15 of the FCC Rules. Operation is subject to the following two conditions: (1) This device may not cause harmful interference, and (2) this device must accept any interference received, including interference that may cause undesired operation."

**DETAILED VIEW OF FCC DECAL, #17495
 SCALE 4:1**

NOTES:

1. DECAL: SILVER BACKGROUND WITH BLACK LETTERING. USES SINGLE-SIDED, PERMANENT ADHESIVE.

VENDOR REPRESENTATIVE:		DATE:		SARIS CYCLING GROUP 5253 VERONA RD., MADISON WI. 53711 1-800-783-7257 / 1-608-274-1702 WWW.SARIS.COM	
UNLESS OTHERWISE SPECIFIED DIMENSIONS ARE IN METRIC TOLERANCES ARE:		MATERIAL:		CAD GENERATED DRAWING. DO NOT MANUALLY UPDATE DIMENSIONING PER ASME Y14.5M 1994 DO NOT SCALE DRAWING	
METRIC: X mm = .50 .X mm = .25 .XX mm = .15 .XXX mm = .100 ANGLES ±1°		N/A			
		FINISH:		APPROVALS	DATE
		N/A		DRAWN	JRR 4/11/07
				CHECKED	
				RESP ENG	
				MFG ENG	
				PROD. REP.	
				THE INFORMATION CONTAINED IN THIS DRAWING IS THE SOLE CONFIDENTIAL PROPERTY OF SARIS CYCLING GROUP ANY REPRODUCTION IN PART OR WHOLE WITHOUT THE WRITTEN PERMISSION OF SARIS CYCLING GROUP IS PROHIBITED.	
				TITLE: ASSEMBLY, POWER CARTRIDGE 300 IC	
SCALE		SIZE	DWG. NO.	REV.	
1:2		B	17329_FCC	2	
CAD FILE:				SHEET	1 OF 1