

Test Report for Unlicensed Low Power Transmitter

FCC Applicable Rule Parts: 15.205, 15.207, 15.209

Applicant: Farpointe Data Inc.
2177 Leghorn Street
Mountain View, CA 94043

FCC ID: T8I-DELTA
Model Nos.: Delta 3, Delta 5, Delta 6.4

Description of device:

The DELTA Series Proximity line of OEM proximity readers, cards, and tags are low frequency, non-contact, identification solutions based upon the latest techniques in radio frequency identification (RFID).

The proximity reader has a receiver circuit, a microprocessor, and a 13.56 MHz exciter circuit that includes a magnetic coil. The tags and cards that are read by the reader have a highly reliable radio frequency integrated circuit (RFIC), attached to a magnetic coil inside a durable, environmentally secure plastic housing.

The referenced models all use the same RF transmit and receive circuits, the differences among models consist of coil size, non-RF features such as keypads, and form factors. Model Delta 5 has the largest coil and the highest output power at the fundamental. Model Delta 6.4 is a Delta 5 with a digital keypad entry and is worst-case representative for both radiated and line conducted emissions. Model Delta 3 is identical to model Delta 5 with a smaller coil and lower radiated emissions at the fundamental.

TEST REQUIREMENTS

The referenced device is subject to certification under Part 2 of FCC Rules. The specific emissions limits and test requirements are found in Part 15 of FCC Rules. In addition to the device specific requirements listed in 15.225 (re-printed below), the following Part 15 requirements are universal to all unlicensed transmitters and would also apply:

- 15.19 Labeling requirements
- 15.20 Accessories
- 15.21 Information to user
- 15.31 Measurement standards
- 15.33 Frequency range of measurements
- 15.35 Measurement detector functions and bandwidths
- 15.109 Radiated Emissions (unintentional radiators)
- 15.203 Antenna requirement
- 15.204 External radio frequency power amplifiers and antenna modifications.
- 15.205 Restricted bands of operation.
- 15.207 Conducted limits

15.209 Radiated emission limits, general requirements.
15.225 Operation within the band 13.110 – 14.010 MHz

REVISION INFORMATION AND ATTESTATION OF RESULTS

Report No: 06PR048FCC

REV No.	Description	Revised By:	Date
-	Original Issue	T. Cokenias	10/30/06
1.1	Correct typo Add bandedge plot	T. Cokenias	12/12/06
1.2	Include Delta 5 model information	T. Cokenias	12/13/06

FCC ID: T8I-DELTA meets all FCC requirements for a device of this type.

THOMAS N. COKENIAS

13 December 2006



EMC and Radio Regulatory Consultant
Agent for Farpointe Data Inc.

15.205 Restricted bands of operation.

Only spurious emissions are permitted in any of the frequency bands listed below: The field strength of emissions appearing within these frequency bands shall not exceed the limits shown in Section 15.209.

MHz	MHz	MHz	GHz
0.090 - 0.110	16.42 - 16.423	399.9 - 410	4.5 - 5.15
10.495 - 0.505	16.69475 - 16.69525	608 - 614	5.35 - 5.46
2.1735 - 2.1905	16.80425 - 16.80475	960 - 1240	7.25 - 7.75
4.125 - 4.128	25.5 - 25.67	1300 - 1427	8.025 - 8.5
4.17725 - 4.17775	37.5 - 38.25	1435 - 1626.5	9.0 - 9.2
4.20725 - 4.20775	73 - 74.6	1645.5 - 1646.5	9.3 - 9.5
6.215 - 6.218	74.8 - 75.2	1660 - 1710	10.6 - 12.7
6.26775 - 6.26825	108 - 121.94	1718.8 - 1722.2	13.25 - 13.4
6.31175 - 6.31225	123 - 138	2200 - 2300	14.47 - 14.5
8.291 - 8.294	149.9 - 150.05	2310 - 2390	15.35 - 16.2
8.362 - 8.366	156.52475 - 156.52525	2483.5 - 2500	17.7 - 21.4
8.37625 - 8.38675	156.7 - 156.9	2655 - 2900	22.01 - 23.12
8.41425 - 8.41475	162.0125 - 167.17	3260 - 3267	23.6 - 24.0
12.29 - 12.293	167.72 - 173.2	3332 - 3339	31.2 - 31.8
12.51975 - 12.52025	240 - 285	3345.8 - 3358	36.43 - 36.5
12.57675 - 12.57725	322 - 335.4	3600 - 4400	
13.36 - 13.41			

15.209 Radiated emission limits, general requirements.

Except as provided elsewhere in this paragraph the emissions from an intentional radiator shall not exceed the field strength levels specified in the following table:

Frequency (MHz)	Field Strength uV/m	Measurement distance, m
0.009 - 0.490	2400/F(kHz)	300
0.490 - 1.705	24000/F (kHz)	30
1.705 - 30.0	30	30
30 - 88	100 **	3
88 - 216	150 **	3
216 - 960	200 **	3
Above 960	500	3

** Except as provided in paragraph (g), fundamental emissions from intentional radiators operating under this Section shall not be located in the frequency bands 54-72 MHz, 76-88 MHz, 174-216 MHz or 470-806 MHz.

15.225 Operation within the band 13.110 – 14.010 MHz.

- (a) The field strength of any emissions within the band 13.553-13.567 MHz shall not exceed 15,848 microvolts/meter (= 84 dBuV/m) at 30 meters.
- (b) Within the bands 13.410-13.553 MHz and 13.567-13.710 MHz, the field strength of any emissions shall not exceed 334 microvolts/meter (=50.5dBuV/m) at 30 meters.
- (c) Within the bands 13.110-13.410 MHz and 13.710-14.010 MHz the field strength of any emissions shall not exceed 106 microvolts/meter (=40.5 dBuV/m) at 30 meters.
- (d) The field strength of any emissions appearing outside of the 13.110-14.010 MHz band shall not exceed the general radiated emission limits in § 15.209.
- (e) The frequency tolerance of the carrier signal shall be maintained within +/- 0.01% of the operating frequency over a temperature variation of -20 degrees to +50 degrees C at normal supply voltage, and for a variation in the primary supply voltage from 85% to 115% of the rated supply voltage at a temperature of 20 degrees C. For battery operated equipment, the equipment tests shall be performed using a new battery.
- (f) In the case of radio frequency powered tags designed to operate with a device authorized under this section, the tag may be approved with the device or be considered as a separate device subject to its own authorization. Powered tags approved with a device under a single application shall be labeled with the same identification number as the device.

Test Set-up Diagram

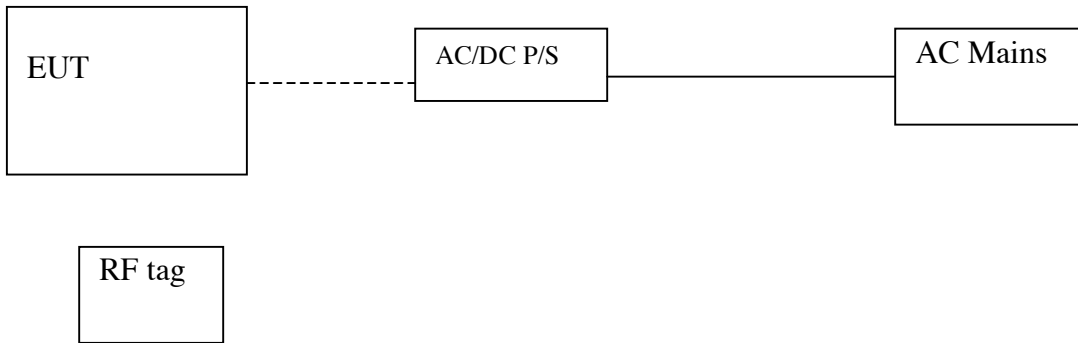

TEST EQUIPMENT LIST				
Name of Equipment	Manufacturer	Model No.	Serial No.	Due Date
LISN, 10 kHz ~ 30 MHz	FCC	LISN-50/250-25-2	2023	8/30/06
EMI Test Receiver	R & S	ESHS 20	827129/006	11/3/06
Spectrum Analyzer 3 Hz ~ 44 GHz	Agilent / HP	E4446A	MY45300064	12/19/06
EMI Receiver, 9 kHz ~ 2.9 GHz	Agilent / HP	8542E	3942A00286	2/4/07
RF Filter Section	Agilent / HP	85420E	3705A00256	2/4/07
Antenna, Bilog 30 MHz ~ 2 Ghz	Sunol Sciences	JB1	A121003	9/3/06
Antenna, Activer Loop	EMCO	6502	9202-2722	9/4/06

**15.205 and 15.209 Radiated Emissions
Radiated Test Set-up, 13.56 - 30MHz**

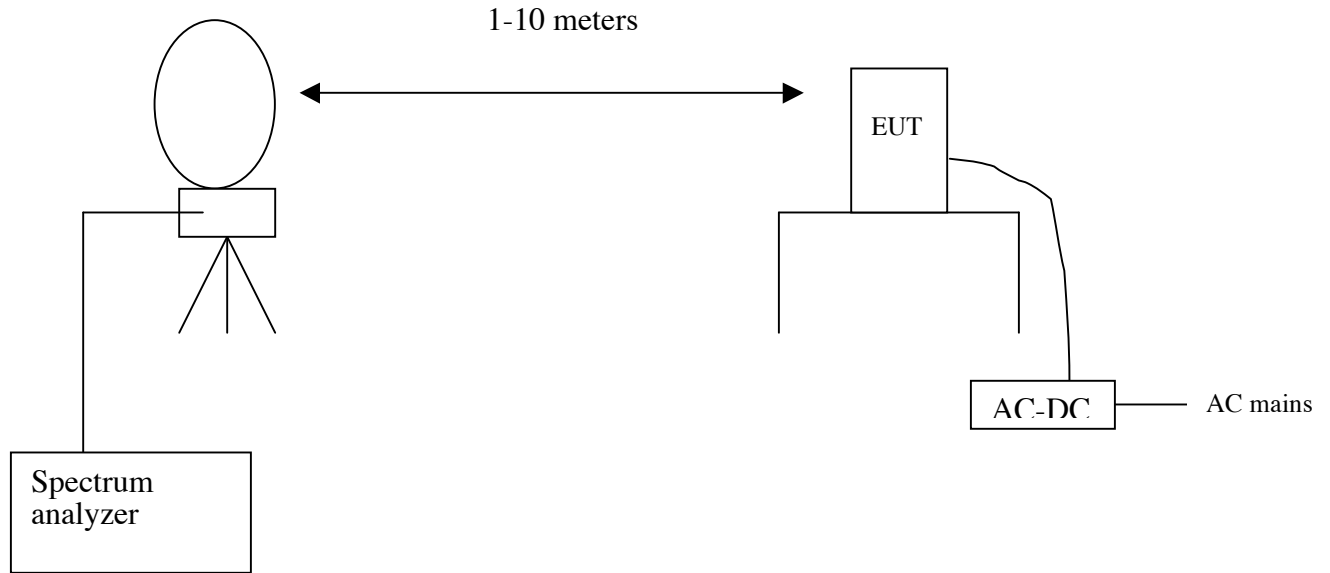

15.205 and 15.209 Radiated Emissions Radiated Test Set-up, 30 - 1000 MHz

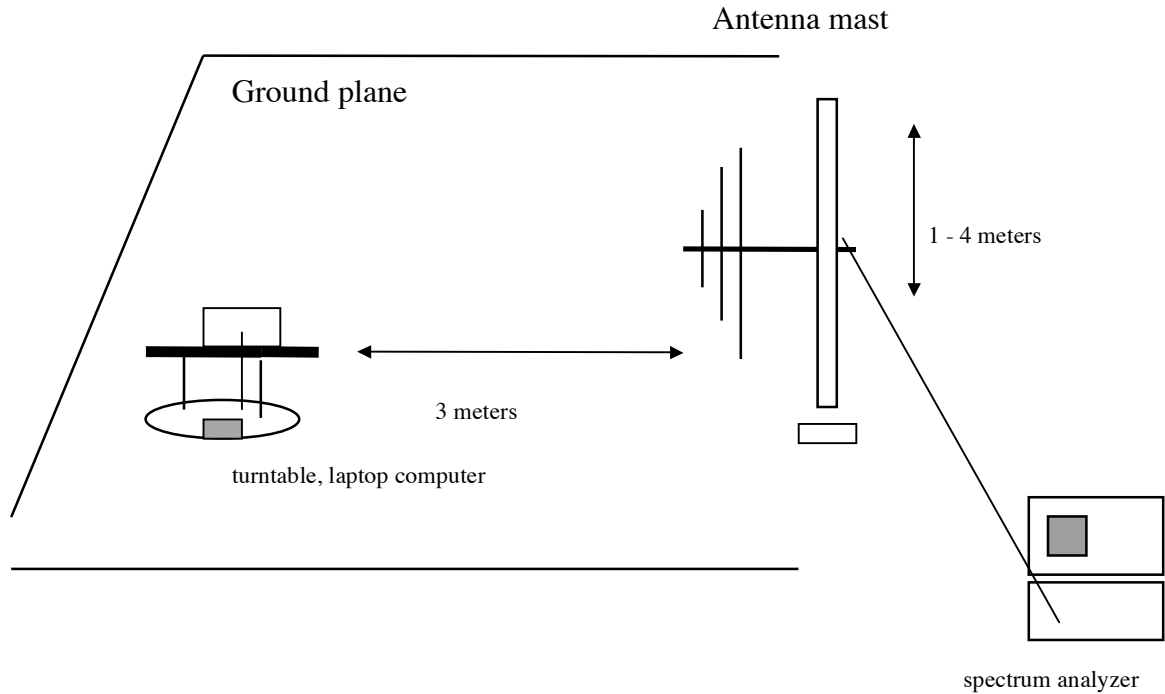

Test Procedures, 13.56 – 30 MHz

The EUT was placed on a non-conductive table located on a large open grassy area free of nearby metal obstructions. The loop antenna was placed at a location 10m from the EUT. Radiated emissions were measured with the loop antenna both parallel and perpendicular to the plane of the EUT loop antenna. For low level harmonic and bandedge emissions, antenna distance was decreased to 1m

Test Procedures, 30 -1000 MHz

The EUT was placed on a turntable in a 5m anechoic chamber. The EUT was set to normal operating conditions (constantly transmitting). Radiated emissions from the EUT were measured according to the dictates of ANSI C63.4. Because the EUT is DC operation only, the EUT was run off a 12V battery so that low frequency (30-100 MHz) emissions from an AC/DC converter would not contaminate test results.

Test Results

EUT emissions are below noise floor or at least 8 dB below required limits.

Radiated Emissions, 13.56 – 30 MHz

FCC Part 15, Subpart B & C												10 Meter Distance Measurement At Open Field	
Project #: 06U10559													
Model #: DELTA5													
Tester: Thanh Nguyen													
Date: 08/19/2006													
Standard: FCC 15.225													
Frequency (MHz)	PK (dBu/V)	QP (dBu/V)	AV (dBu/V)	AF (dB/m)	Distance Correction (dB)	PK Corrected Reading (dBuV/m)	AV Corrected Reading (dBuV/m)	QP Limit (dBuV/m)	AV Limit (dBuV/m)	PK Margin (dB)	AV Margin (dB)	Notes	
Loop Antenna Face On:													
13.56	55.5	53.2		10.556	-19.08	44.67		84.00		-39.3		10m Meas. distance(Fund.)	
27.12	27.4	27.4		9.0456	-59.08	-22.64		29.50		-52.1		1m distance	
13.5529	54.8			10.5553	-59.08	6.27		50.48		-44.2		1m distance(Edge)	
13.5670	54.1			10.5567	-59.08	5.57		50.48		-44.9		1m distance(Edge)	
13.3473	42.1			10.5347	-59.08	-6.45		40.50		-47.0		1m distance(Edge)	
13.7712	33.3			10.5771	-59.08	-15.21		40.50		-55.7		1m distance(Edge)	
Loop Antenna Face Off:													
13.56	48.6			10.556	-19.08	40.07		84.00		-43.9		10m Meas. distance(Fund.)	
27.12	27.5	27.5		9.0456	-59.08	-22.54		29.50		-52.0		1m distance	
13.553	47.9			10.5553	-59.08	-0.63		50.48		-51.1		1m distance(Edge)	
13.3506	48.1			10.5351	-59.08	-0.45		40.50		-40.9		1m distance(Edge)	
13.71	35.3			10.571	-59.08	-13.21		50.48		-63.7		1m distance(Edge)	
13.7709	34.4			10.5771	-59.08	-14.11		40.50		-54.6		1m distance(Edge)	
* No more emissions were found up to 30MHz													
Note: The emission limits are based on measurements employing a CISPR quasi-peak detector except for the frequency bands 9–90 kHz, 110–490 kHz and above 10000Mhz. Radiated emission limits in these three bands are based on measurements employing an average detector.													
P.K. = Peak													
Q.P. = Quasi Peak Readings												Below 150kHz => RBW=VBW=200 or 300Hz	
A.F. = Antenna factor												Above 150kHz =>RBW=VBW=9 or 10kHz (Average => VBW=10Hz)	

Emission Bandwidth Plot

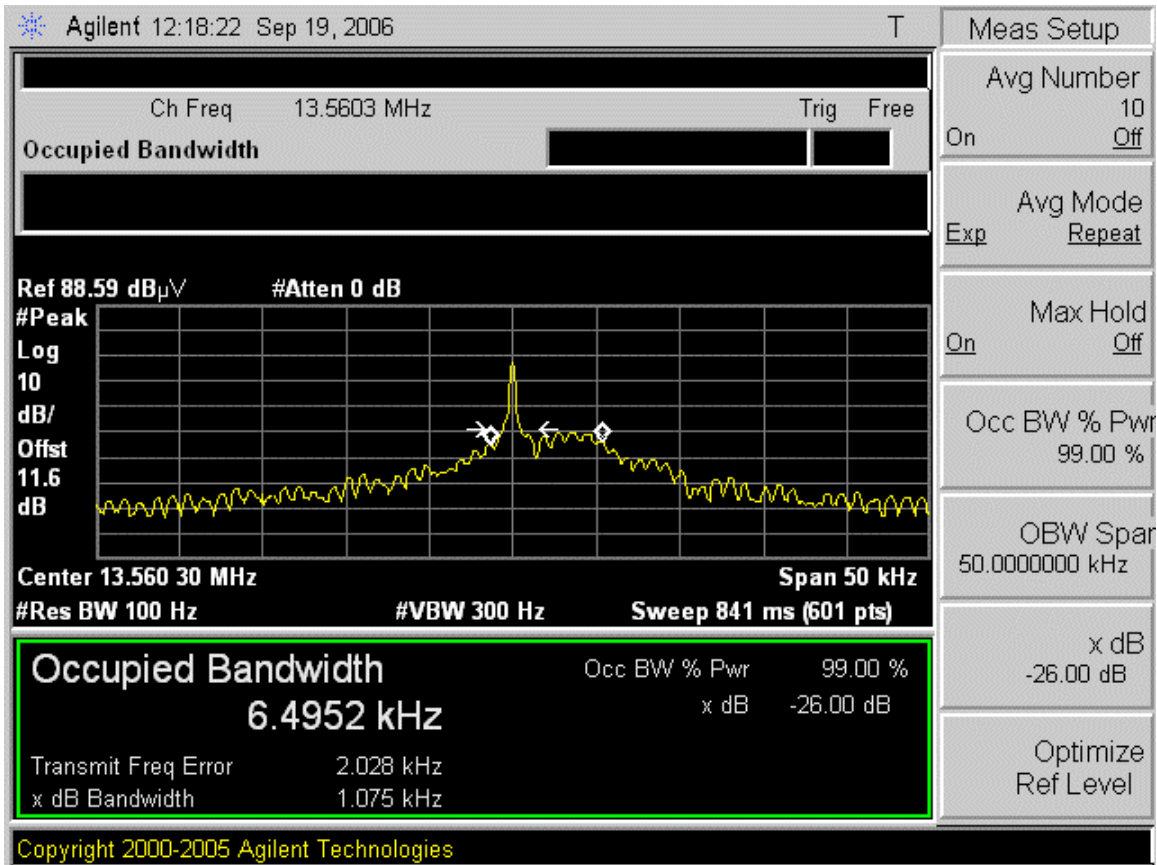

Out of Band emissions: 30-1000 MHz, Vertical



561F Monterey Road
 Morgan Hill, CA 95037
 Tel: (408) 463-0888
 Fax: (408) 463-0885

Data#: 85 File#: below 1GHz.EMI Date: 08-28-2006 Time: 14:56:45

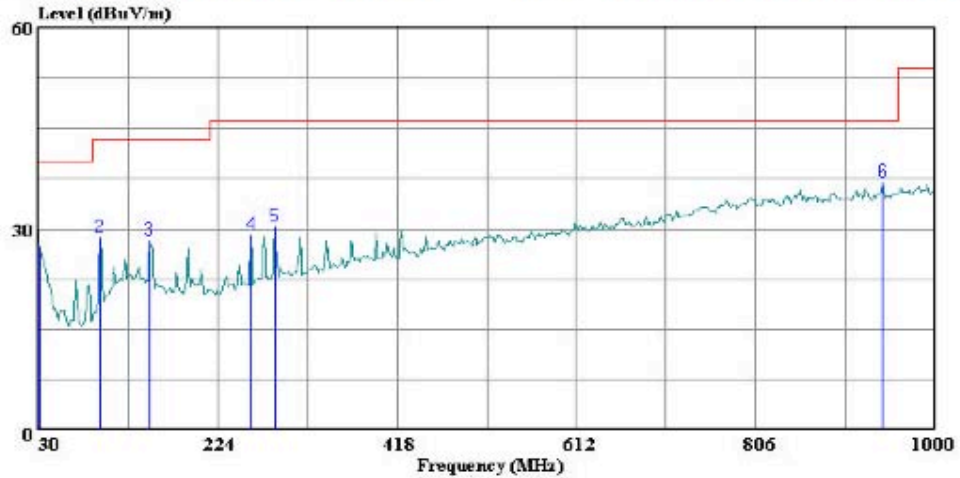

(Audix ATC)

Trace: 84

Ref Trace:

Condition: FCC CLASS-B VERTICAL
 Test Operator: : Gordon Andrews
 Company: : FARPOINTE
 Project #: : 06U10437
 Configuration: : EUT stand alone, with 12V Battery
 Model : DELTA 5 Rev 4 with EMI fixes
 Mode of Operation: Tx

Page: 1

	Read			Limit	Over	
Peak	Level	Factor	Level	Line	Limit	Remark
	dBuV	dB	dBuV/m	dBuV/m	dB	
1	30.970	6.82	20.45	27.27	40.00	-12.73 Peak
2	96.930	17.98	10.58	28.56	43.50	-14.94 Peak
3	150.280	14.16	14.10	28.26	43.50	-15.24 Peak
4	259.890	14.90	14.25	29.15	46.00	-16.85 Peak
5	286.080	15.16	15.16	30.32	46.00	-15.68 Peak
6	943.740	10.55	26.43	36.98	46.00	-9.02 Peak

Out of Band emissions: 30-1000 MHz, Horizontal



561F Monterey Road
 Morgan Hill, CA 95037
 Tel: (408) 463-0888
 Fax: (408) 463-0885

Data#: 87 File#: below 1GHz.EMI Date: 08-28-2006 Time: 15:03:08

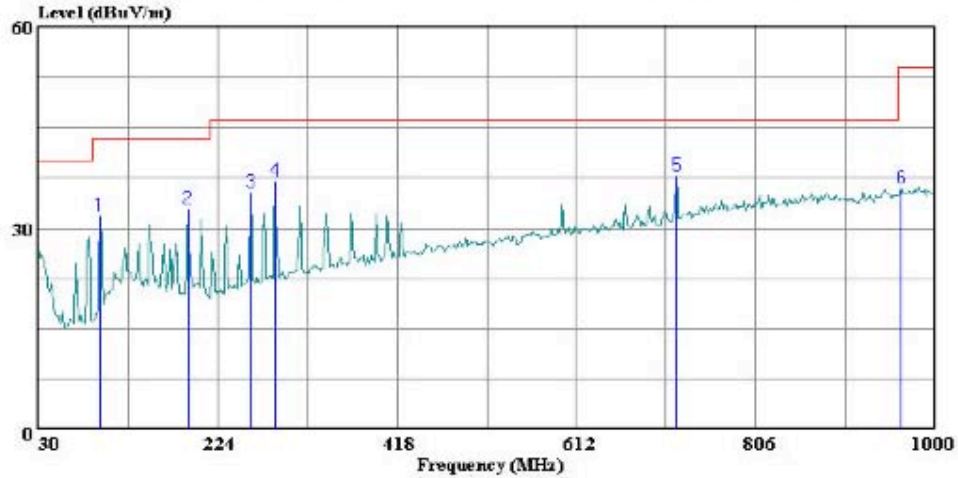

(Auxix ATC)

Trace: 86

Ref Trace:

Condition: FCC CLASS-B HORIZONTAL
 Test Operator: : Gordon Andrews
 Company: : FARPOINTE
 Project #: : 06U10437
 Configuration: : EUT stand alone, with 12V Battery
 Model : DELTA 5 Rev 4 with EMI fixes
 Mode of Operation: Tx

Page: 1

	Read	Limit	Over				
Freq	Level	Factor	Level	Line	Limit	Remark	
MHz	dBuV	dB	dBuV/m	dBuV/m	dB		
1	96.930	21.18	10.58	31.76	43.50	-11.74	Peak
2	191.990	19.49	13.25	32.74	43.50	-10.76	Peak
3	259.890	20.97	14.25	35.22	46.00	-10.78	Peak
4	286.080	21.79	15.16	36.95	46.00	-9.05	Peak
5	720.640	14.30	23.49	37.79	46.00	-8.21	Peak
6	963.140	9.22	26.61	35.83	54.00	-18.17	Peak

AC Line Conducted Emissions Test Requirement: 15.107, 15.207

Test Set-up

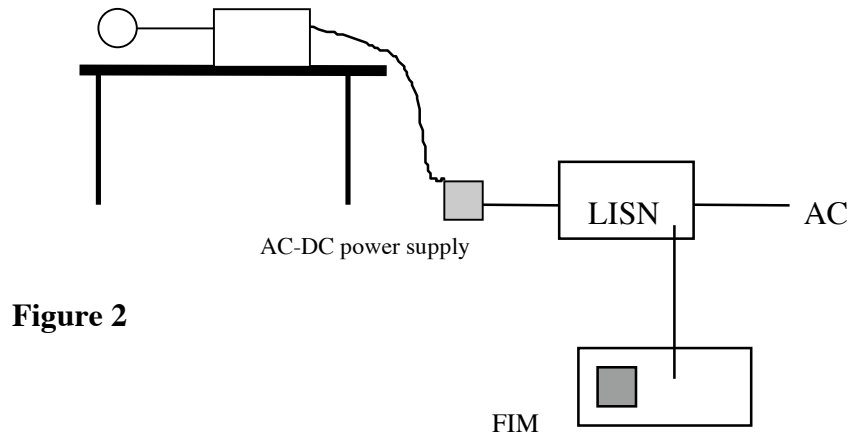

Test Procedure

1. The EUT was placed on a wooden table 40 cm from a vertical ground plane and approximately 80 cm above the horizontal ground plane on the floor. The EUT was set to transmit in normally.
2. Line conducted data was recorded for both NEUTRAL and HOT lines.

Test Results

PASS. Refer to data plots below.

With RF radiating coil antenna connected



Compliance Certification Services
561F Monterey Road
Morgan Hill, CA 95037
Tel: (408) 463-0885
Fax: (408) 463-0888

Data#: 55 File#: 063006.emi Date: 06-30-2006 Time: 11:32:33

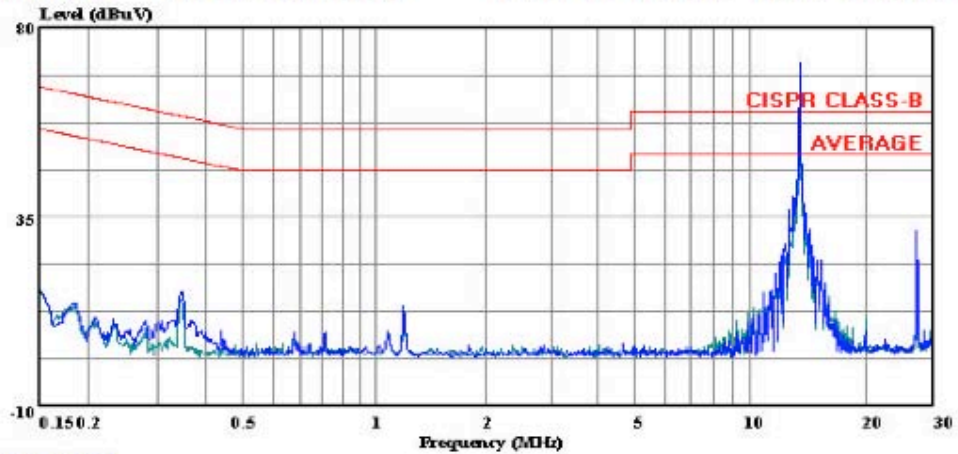

(Auxiliary ATC)

Trace: 51

Ref Trace:

Condition: CISPR CLASS-B
Test Operator : Gordon Andrews
Project # : 06U10316
Company : Farpointe
EUT configuration: EUT w/ ELPAC AC pwr Adater
EUT mode : Normal
Power Source : 115 VAC, 60 Hz
: Peak, Line 1:(Black), Line 2:(Green)
: Model: Delta 5

With coil removed, circuit terminated in coil characteristic impedance Line 1



Compliance Certification Services
561F Monterey Road
Morgan Hill, CA 95037
Tel: (408) 463-0885
Fax: (408) 463-0888

Data#: 21 File#: 063006.emi Date: 06-30-2006 Time: 09:41:42

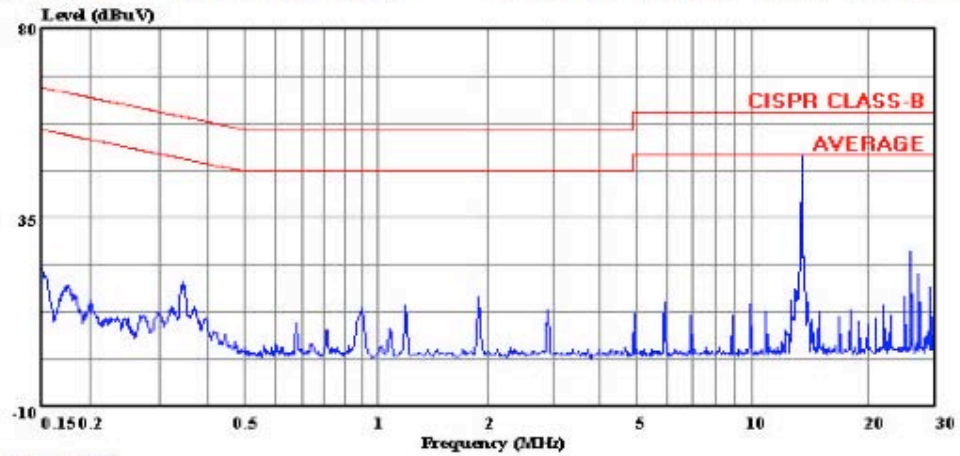

(Auxix ATC)

Trace:

Ref Trace:

Condition: CISPR CLASS-B
Test Operator : Gordon Andrews
Project # : 06U10316
Company : Farpointe
EUT configuration: EUT w/ ELPAC AC pwr Adater
EUT mode : Normal
Power Source : 115 VAC, 60 Hz
: Peak, Line 1:(Black), Line 2:(Green)
: Model: Delta 5 resistor instead of coil.

With coil removed, circuit terminated in coil characteristic impedance Line 2



Compliance Certification Services
561F Monterey Road
Morgan Hill, CA 95037
Tel: (408) 463-0885
Fax: (408) 463-0888

Data#: 21 File#: 063006.emi Date: 06-30-2006 Time: 09:41:42

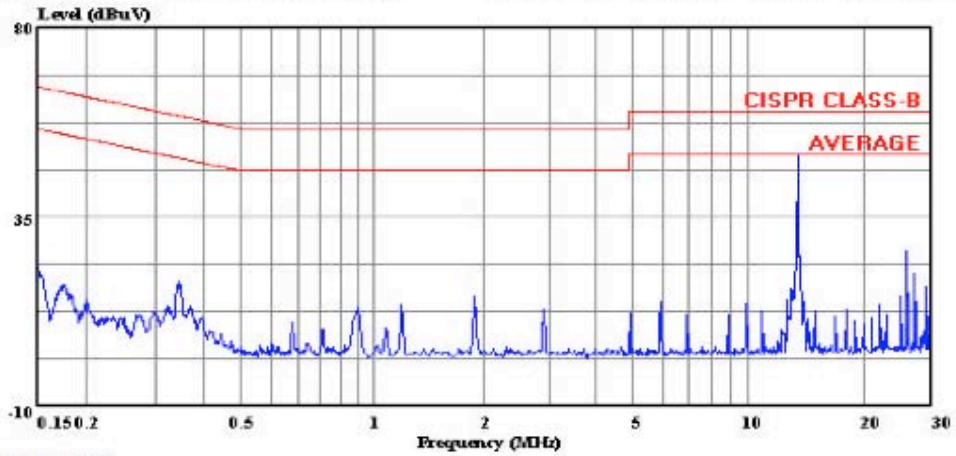

(Auxiliary ATC)

Trace:

Ref Trace:

Condition: CISPR CLASS-B
Test Operator : Gordon Andrews
Project # : 06U10316
Company : Farpointe
EUT configuration: EUT w/ ELPAC AC pwr Adater
EUT mode : Normal
Power Source : 115 VAC, 60 Hz
: Peak, Line 2
: Model: Delta 5 resistor instead of coil.

Frequency Stability Test Requirement 15.255(d)

Test Limits

Within +/- 0.01% of fundamental from -20C to +50C.

Within +/- 0.01% of fundamental at 20C for supply voltage 85% and 115% of nominal

0.01% of 13.560 MHz = 1356 Hz maximum variation allowed

Allowed frequency variation: 13.558644MHz – 13.561356 MHz

Test Set-up

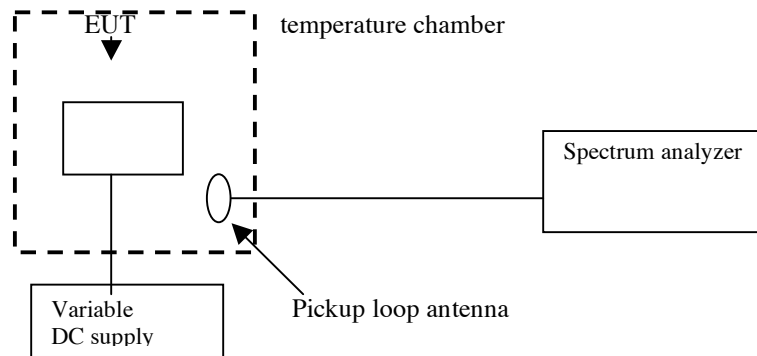

Test Procedures

1. Spectrum analyzer center frequency was set to 13.56 MHz operating frequency. Frequency was measured at +25C using spectrum analyzer marker function.
2. The transmitter was allowed to stabilize at every 10 degrees C from -20C to +50C and measurements were recorded at each temperature.

Test Results

<u>Temp, °C</u>	<u>Frequency</u>	<u>Delta, Hz</u>
25	13.560 296	+296
50	13.560 208	+208
40	13.560 204	+204
30	13.560 224	+224
20	13.560 305	+305
10	13.560 384	+384
0	13.560 406	+406
-10	13.560 397	+397
-20	13.560 363	+363

Test Set-Up Photographs

Radiated emissions below 30 MHz, 10m



Radiated Emissions, 30 – 1000 MHz

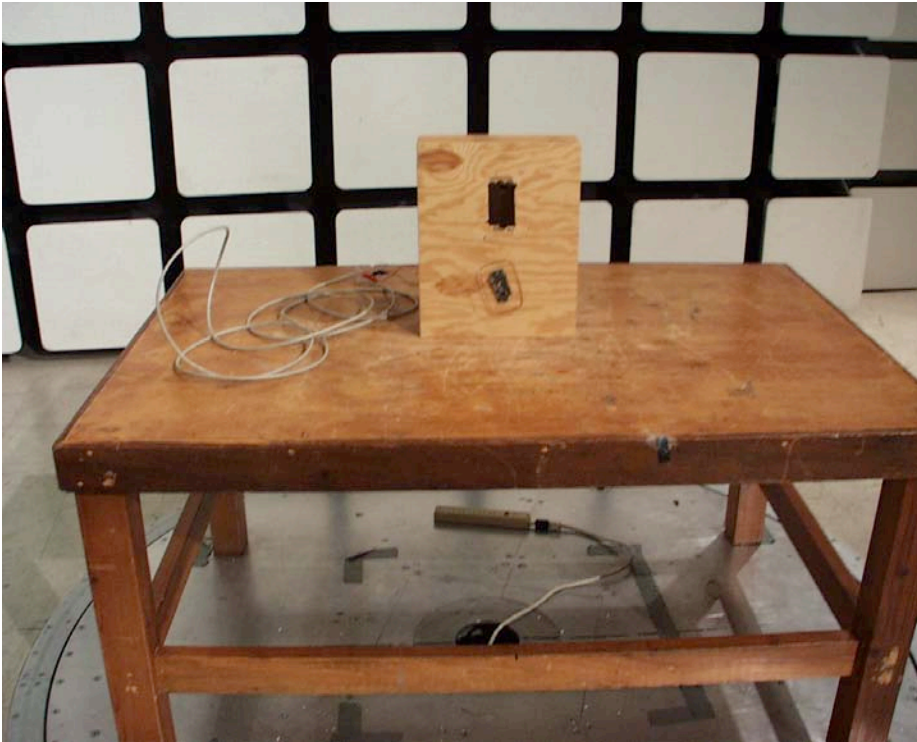

AC Line Conducted Emissions

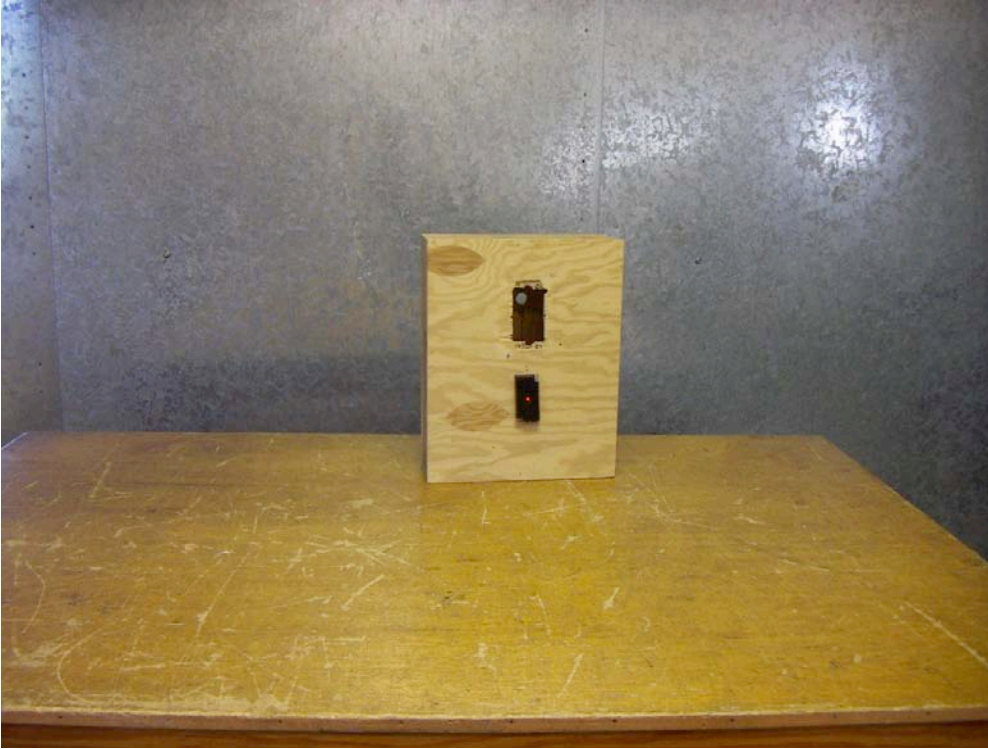

Frequency Stability

