

2.1.8. 5G NSA Bands

According to February 2021 TCB Workshop:

- For non-stand-alone configurations, both LTE and 5G-NR are added to derive a total SAR.

Following guidance from TCB Workshop October 2020:

- SAR testing for LTE and NR will be performed separately, and applying FCC KDB 447498 techniques for simultaneous LTE+NR:
 - If the single uplink 1-g SAR values for each band are both less than 0.8 W/kg and the algebraic summation of the 1-g SAR values are less than 1.45 W/kg, additional measurements are not needed.

NSA	CC1			CC2			NSA
	Band	Tune-up limit	Reported SAR	Band	Tune-up limit	Reported SAR	CA Summation
2A-n5A	2A	24.5	0.108	n5A	25.0	0.094	0.202
66A-n5A	66A	24.5	0.094	n5A	25.0	0.094	0.188
26A-n41A	26A	25.0	0.263	n41A	24.5	0.026	0.289
5A-n66A	5A	24.5	0.281	n66A	24.5	0.045	0.326
12A-n66A	12A	24.5	0.211	n66A	24.5	0.045	0.256
2A-n71A	2A	24.5	0.108	n71A	24.5	0.021	0.129
66A-n71A	66A	24.5	0.094	n71A	24.5	0.021	0.115
7A-n78A	7A	25.0	0.135	n78A	24.5	0.013	0.148
38A-n78A	38A	24.5	0.081	n78A	24.5	0.013	0.094

2.2. MIMO2 port: MIMO 2 Antenna (External Shark fin)

2.2.1. LTE Bands

- LTE 42

Band	BW	Modulation	Mode	MPR	Average Output Power (dBm)		
					Low CH	Mid CH	High CH
					3410.0 MHz	3500.0 MHz	3590.0 MHz
LTE B42	20 MHz	QPSK	1RB Low	0	25.16	24.66	25.08
			1RB Mid	0	24.84	24.51	25.05
			1RB High	0	25.15	24.61	25.12
			50% Low	1	24.17	23.63	24.02
			50% Mid	1	24.12	23.58	24.03
			50% High	1	24.11	23.60	24.01
			100%	1	24.16	23.60	24.01
		16-QAM	1RB Low	1	24.59	23.50	24.30
			1RB Mid	1	24.04	23.39	24.12
			1RB High	1	24.00	23.43	24.20
			50% Low	2	23.17	22.65	23.06
			50% Mid	2	23.10	22.62	23.06
			50% High	2	23.08	22.61	23.03
			100%	2	23.14	22.63	23.00
Band	BW	Modulation	Mode	MPR	Low CH	Mid CH	High CH
					3407.5 MHz	3500.0 MHz	3592.5 MHz
LTE B42	15 MHz	QPSK	1RB Low	0	25.14	24.61	25.03
			1RB Mid	0	25.16	24.35	25.14
			1RB High	0	25.12	24.64	24.97
			50% Low	1	24.30	23.63	24.05
			50% Mid	1	24.24	23.62	24.03
			50% High	1	24.23	23.63	24.03
			100%	1	24.27	23.63	24.07
		16-QAM	1RB Low	1	24.33	23.81	24.21
			1RB Mid	1	24.13	24.33	24.08
			1RB High	1	24.43	24.16	24.22
			50% Low	2	23.25	22.61	23.07
			50% Mid	2	23.24	22.56	23.06
			50% High	2	23.24	22.58	23.06
			100%	2	23.22	22.64	23.02

Band	BW	Modulation	Mode	MPR	Average Output Power (dBm)		
					Low CH	Mid CH	High CH
					3405.0 MHz	3500.0 MHz	3595.0 MHz
LTE B42	10 MHz	QPSK	1RB Low	0	25.18	24.51	25.04
			1RB Mid	0	25.01	24.27	24.81
			1RB High	0	25.22	24.49	24.97
			50% Low	1	24.24	23.57	23.97
			50% Mid	1	24.19	23.55	23.96
			50% High	1	24.20	23.55	24.00
			100%	1	24.25	23.57	24.01
		16-QAM	1RB Low	1	24.39	23.88	23.89
			1RB Mid	1	24.27	23.71	24.21
			1RB High	1	24.30	23.68	24.27
			50% Low	2	23.33	22.61	23.01
			50% Mid	2	23.24	22.54	22.97
			50% High	2	23.27	22.55	22.98
			100%	2	23.25	22.55	22.97
Band	BW	Modulation	Mode	MPR	Low CH	Mid CH	High CH
LTE B42	5 MHz	QPSK	1RB Low	0	25.36	24.69	25.04
			1RB Mid	0	25.44	24.60	25.23
			1RB High	0	25.31	24.61	25.07
			50% Low	1	24.27	23.63	24.03
			50% Mid	1	24.21	23.60	24.02
			50% High	1	24.27	23.61	24.03
			100%	1	24.23	23.62	24.01
		16-QAM	1RB Low	1	24.64	23.86	24.36
			1RB Mid	1	24.79	23.99	24.57
			1RB High	1	24.56	23.91	24.25
			50% Low	2	23.26	22.70	23.01
			50% Mid	2	23.19	22.57	23.03
			50% High	2	23.21	22.61	22.99
			100%	2	23.24	22.63	23.01

2.2.2. 5G SA Bands

- n77

NR Band 77 (SCS 30kHz)				Average Output Power (dBm)		
BW	MCS Index	RB Size	RB Offset	Low	Mid	High
		Channel		623334	650000	676666
		Frequency (MHz)		3350.01	3750	4149.99
100 MHz	pi/2 BPSK	1	0	21.91	22.87	22.25
		1	136	22.04	22.66	22.22
		1	272	22.25	22.17	22.21
		136	0	22.25	22.82	22.15
		136	68	22.10	22.02	22.13
		136	136	21.95	22.79	22.33
		273	0	22.17	22.13	22.33
	QPSK	1	0	21.12	21.14	21.01
		1	136	21.45	21.31	21.30
		1	272	21.19	21.10	21.55
		136	0	21.20	21.43	20.98
		136	68	21.37	21.25	21.27
		136	136	21.31	21.39	21.16
		273	0	21.45	21.28	21.34
	16QAM	1	0	20.18	20.15	20.23
		1	136	20.30	20.12	20.70
		1	272	20.54	20.20	20.57
		136	0	20.41	20.02	20.62
		136	68	20.28	20.39	20.64
		136	136	20.55	20.17	20.37
		273	0	20.29	20.56	20.48
	64QAM	1	0	19.43	19.13	19.18
		1	136	19.65	19.14	19.29
		1	272	19.28	19.26	19.55
		136	0	19.35	19.18	19.58
		136	68	19.42	19.18	19.31
		136	136	19.24	19.26	19.30
		273	0	19.43	19.15	19.33
	256QAM	1	0	18.33	18.60	18.60
		1	136	18.39	18.64	18.41
1		272	18.72	18.64	18.27	
136		0	18.83	18.78	18.37	
136		68	18.26	18.43	18.27	
136		136	18.34	18.27	18.57	
273		0	18.22	18.59	18.33	

NR Band 77 (SCS 30kHz)				Average Output Power (dBm)		
BW	MCS Index	RB Size	RB Offset	Low	Mid	High
		Channel		623000	650000	67700
		Frequency (MHz)		3345	3750	4155
90 MHz	pi/2 BPSK	1	0	21.99	22.20	21.98
		1	122	21.94	22.39	22.07
		1	244	22.37	22.08	22.01
		122	0	22.28	22.74	22.28
		122	61	22.37	22.45	22.27
		122	122	22.38	22.31	22.06
		245	0	22.14	22.01	22.27
	QPSK	1	0	21.31	21.56	21.17
		1	122	21.31	21.28	21.11
		1	244	21.44	21.44	21.13
		122	0	21.18	21.26	21.09
		122	61	21.50	21.60	21.23
		122	122	21.17	21.34	21.32
		245	0	21.39	21.21	21.39
	16QAM	1	0	20.54	20.46	20.46
		1	122	20.51	20.12	20.28
		1	244	20.52	20.68	20.58
		122	0	20.51	20.38	20.17
		122	61	20.35	20.44	20.62
		122	122	20.32	20.32	20.43
		245	0	20.14	20.21	20.62
	64QAM	1	0	19.45	19.58	19.69
		1	122	19.36	19.01	19.52
		1	244	19.20	19.33	19.09
		122	0	19.62	19.26	19.65
		122	61	19.62	19.08	19.69
		122	122	19.23	19.55	19.61
		245	0	19.66	19.43	19.56
	256QAM	1	0	18.65	18.36	18.84
		1	122	18.74	18.34	18.26
1		244	18.80	18.69	18.80	
122		0	18.42	18.72	18.89	
122		61	18.66	18.23	18.51	
122		122	18.86	18.31	18.77	
245		0	18.32	18.65	18.84	

NR Band 77 (SCS 30kHz)				Average Output Power (dBm)		
BW	MCS Index	RB Size	RB Offset	Low	Mid	High
		Channel		622668	650000	677332
		Frequency (MHz)		3340.02	3750	4159.98
80 MHz	pi/2 BPSK	1	0	22.08	22.57	22.07
		1	108	22.14	22.72	22.32
		1	216	22.04	22.09	22.08
		108	0	22.14	21.99	22.38
		108	54	22.37	22.03	22.38
		108	108	22.24	22.30	22.00
		217	0	22.00	22.39	21.99
	QPSK	1	0	21.32	21.60	21.49
		1	108	21.25	21.56	21.00
		1	216	21.52	21.19	21.34
		108	0	21.41	21.32	21.23
		108	54	21.46	21.20	21.34
		108	108	21.51	21.33	20.96
		217	0	21.23	21.37	21.09
	16QAM	1	0	20.37	20.15	20.48
		1	108	20.56	20.05	20.16
		1	216	20.63	20.05	20.54
		108	0	20.39	20.47	20.40
		108	54	20.24	20.44	20.64
		108	108	20.09	20.38	20.10
		217	0	20.07	20.19	20.68
	64QAM	1	0	19.21	19.40	19.33
		1	108	19.37	19.41	19.32
		1	216	19.50	19.07	19.36
		108	0	19.64	19.30	19.42
		108	54	19.46	19.44	19.67
		108	108	19.21	19.02	19.15
		217	0	19.48	19.25	19.12
	256QAM	1	0	18.48	18.83	18.32
		1	108	18.56	18.76	18.67
1		216	18.55	18.67	18.59	
108		0	18.82	18.55	18.81	
108		54	18.86	18.55	18.87	
108		108	18.59	18.88	18.48	
217		0	18.60	18.82	18.78	

NR Band 77 (SCS 30kHz)				Average Output Power (dBm)		
BW	MCS Index	RB Size	RB Offset	Low	Mid	High
		Channel		622000	650000	678000
		Frequency (MHz)		3330	3750	4170
60 MHz	pi/2 BPSK	1	0	22.37	22.48	21.97
		1	81	22.33	22.31	22.03
		1	161	22.29	22.76	22.38
		81	0	22.00	22.03	22.24
		81	40	22.25	22.03	22.32
		81	81	22.27	22.49	22.35
		162	0	22.41	22.32	21.97
	QPSK	1	0	21.21	21.34	21.40
		1	81	21.18	21.35	21.16
		1	161	21.29	21.38	21.25
		81	0	21.50	21.27	21.18
		81	40	21.40	21.07	21.34
		81	81	21.36	21.55	21.33
		162	0	21.54	21.38	21.42
	16QAM	1	0	20.22	20.42	20.68
		1	81	20.16	20.28	20.15
		1	161	20.32	20.45	20.31
		81	0	20.25	20.32	20.51
		81	40	20.55	20.01	20.47
		81	81	20.08	20.55	20.43
		162	0	20.37	20.15	20.53
	64QAM	1	0	19.49	19.45	19.15
		1	81	19.27	19.25	19.34
		1	161	19.56	19.34	19.27
		81	0	19.58	19.10	19.43
		81	40	19.12	19.57	19.06
		81	81	19.33	19.10	19.42
		162	0	19.23	19.56	19.57
	256QAM	1	0	18.45	18.26	18.75
		1	81	18.27	18.47	18.64
1		161	18.71	18.42	18.41	
81		0	18.36	18.26	18.40	
81		40	18.67	18.42	18.61	
81		81	18.35	18.76	18.23	
162		0	18.21	18.40	18.23	

NR Band 77 (SCS 30kHz)				Average Output Power (dBm)		
BW	MCS Index	RB Size	RB Offset	Low	Mid	High
		Channel		621668	650000	678332
		Frequency (MHz)		3325.02	3750	4174.98
50 MHz	pi/2 BPSK	1	0	22.07	22.46	22.37
		1	66	22.04	22.39	22.37
		1	132	22.13	22.06	22.07
		66	0	22.17	22.54	22.27
		66	33	22.37	22.26	21.97
		66	66	22.07	22.70	22.17
		133	0	22.37	22.45	22.24
	QPSK	1	0	21.54	21.27	21.10
		1	66	21.47	21.13	21.07
		1	132	21.13	21.24	21.05
		66	0	21.36	21.31	21.55
		66	33	21.47	21.32	21.56
		66	66	21.22	21.40	21.43
		133	0	21.54	21.32	20.96
	16QAM	1	0	20.56	20.72	20.62
		1	66	20.16	20.68	20.38
		1	132	20.35	20.76	20.12
		66	0	20.50	20.24	20.44
		66	33	20.46	20.68	20.47
		66	66	20.49	20.02	20.22
		133	0	20.31	20.19	20.64
	64QAM	1	0	19.65	19.53	19.69
		1	66	19.51	19.21	19.42
		1	132	19.26	19.03	19.22
		66	0	19.30	19.12	19.35
		66	33	19.53	19.35	19.64
		66	66	19.14	19.05	19.64
		133	0	19.67	19.01	19.41
256QAM	1	0	18.78	18.50	18.27	
	1	66	18.64	18.78	18.75	
	1	132	18.78	18.78	18.82	
	66	0	18.80	18.70	18.51	
	66	33	18.49	18.53	18.67	
	66	66	18.47	18.37	18.87	
	133	0	18.73	18.72	18.85	

NR Band 77 (SCS 30kHz)				Average Output Power (dBm)		
BW	MCS Index	RB Size	RB Offset	Low	Mid	High
		Channel		621334	650000	678666
		Frequency (MHz)		3320.01	3750	4179.99
40 MHz	pi/2 BPSK	1	0	22.38	22.53	22.29
		1	53	22.27	22.40	22.02
		1	105	22.47	22.54	22.20
		53	0	22.19	22.56	22.12
		53	26	22.01	22.24	22.26
		53	53	21.99	22.21	22.14
		106	0	21.93	22.07	22.31
	QPSK	1	0	21.13	21.15	21.59
		1	53	21.34	21.20	21.17
		1	105	21.39	21.58	21.04
		53	0	21.14	21.43	21.53
		53	26	21.18	21.16	21.48
		53	53	21.25	21.51	21.57
		106	0	21.41	21.53	21.04
	16QAM	1	0	20.22	20.52	20.37
		1	53	20.52	20.19	20.46
		1	105	20.37	20.06	20.49
		53	0	20.11	20.09	20.16
		53	26	20.19	20.59	20.69
		53	53	20.06	20.74	20.32
		106	0	20.43	20.62	20.43
	64QAM	1	0	19.13	19.14	19.11
		1	53	19.35	19.40	19.66
		1	105	19.55	19.24	19.68
		53	0	19.11	19.36	19.54
		53	26	19.60	19.35	19.47
		53	53	19.16	19.54	19.19
		106	0	19.61	19.58	19.19
256QAM	1	0	18.73	18.76	18.24	
	1	53	18.89	18.82	18.34	
	1	105	18.33	18.73	18.67	
	53	0	18.70	18.83	18.22	
	53	26	18.72	18.56	18.61	
	53	53	18.48	18.75	18.79	
	106	0	18.24	18.33	18.67	

NR Band 77 (SCS 30kHz)				Average Output Power (dBm)		
BW	MCS Index	RB Size	RB Offset	Low	Mid	High
		Channel		620668	650000	679332
		Frequency (MHz)		3310.02	3750	4189.98
20 MHz	pi/2 BPSK	1	0	22.39	22.19	22.30
		1	25	22.18	22.39	22.36
		1	50	22.10	22.34	22.04
		25	0	22.15	22.46	21.97
		25	12	21.93	22.03	22.03
		25	25	22.27	22.85	22.29
		51	0	22.25	22.47	22.18
	QPSK	1	0	21.54	21.02	20.98
		1	25	21.49	21.13	21.34
		1	50	21.44	21.03	21.49
		25	0	21.49	21.16	21.49
		25	12	21.17	21.43	21.18
		25	25	21.46	21.10	21.01
		51	0	21.47	21.46	21.37
	16QAM	1	0	20.57	20.17	20.47
		1	25	20.25	20.19	20.48
		1	50	20.06	20.78	20.13
		25	0	20.63	20.58	20.12
		25	12	20.53	20.51	20.47
		25	25	20.08	20.21	20.53
		51	0	20.05	20.23	20.17
	64QAM	1	0	19.18	19.13	19.14
		1	25	19.48	19.54	19.15
		1	50	19.17	19.00	19.05
		25	0	19.53	19.48	19.39
		25	12	19.61	19.43	19.48
		25	25	19.68	19.20	19.29
		51	0	19.13	19.56	19.66
	256QAM	1	0	18.69	18.69	18.89
		1	25	18.36	18.47	18.72
1		50	18.24	18.58	18.36	
25		0	18.28	18.55	18.23	
25		12	18.60	18.31	18.33	
25		25	18.66	18.36	18.35	
51		0	18.81	18.55	18.73	

NR Band 77 (SCS 30kHz)				Average Output Power (dBm)		
BW	MCS Index	RB Size	RB Offset	Low	Mid	High
		Channel		620500	650000	679500
		Frequency (MHz)		3307.5	3750	4192.5
15 MHz	pi/2 BPSK	1	0	21.91	22.49	22.31
		1	19	21.98	22.78	22.01
		1	37	22.24	22.27	22.23
		19	0	21.99	22.73	22.17
		19	9	22.41	22.31	22.26
		19	20	22.46	22.01	22.03
		38	0	22.37	22.53	22.35
	QPSK	1	0	21.53	21.35	21.26
		1	19	21.46	21.42	21.46
		1	37	21.21	21.29	20.99
		19	0	21.47	21.32	21.21
		19	9	21.24	21.07	21.11
		19	20	21.39	21.17	21.02
		38	0	21.25	21.37	21.55
	16QAM	1	0	20.48	20.67	20.55
		1	19	20.57	20.49	20.31
		1	37	20.51	20.77	20.66
		19	0	20.40	20.58	20.25
		19	9	20.62	20.53	20.49
		19	20	20.23	20.69	20.50
		38	0	20.19	20.67	20.63
	64QAM	1	0	19.44	19.06	19.39
		1	19	19.58	19.20	19.12
		1	37	19.45	19.30	19.70
		19	0	19.32	19.14	19.38
		19	9	19.27	19.04	19.17
		19	20	19.17	19.13	19.57
		38	0	19.29	19.27	19.40
256QAM	1	0	18.74	18.76	18.50	
	1	19	18.57	18.35	18.50	
	1	37	18.42	18.44	18.23	
	19	0	18.81	18.56	18.24	
	19	9	18.78	18.83	18.31	
	19	20	18.51	18.70	18.22	
	38	0	18.34	18.38	18.84	

NR Band 77 (SCS 30kHz)				Average Output Power (dBm)		
BW	MCS Index	RB Size	RB Offset	Low	Mid	High
		Channel		620334	650000	679666
		Frequency (MHz)		3305.01	3750	4194.99
10 MHz	pi/2 BPSK	1	0	22.06	22.68	22.35
		1	12	22.20	22.54	22.11
		1	23	22.32	22.63	22.16
		12	0	22.16	22.32	22.15
		12	6	22.38	22.21	22.28
		12	12	21.99	22.59	22.29
		24	0	22.04	22.43	22.17
	QPSK	1	0	21.26	21.43	21.39
		1	12	21.39	21.04	21.28
		1	23	21.35	21.21	21.50
		12	0	21.49	21.05	21.21
		12	6	21.36	21.39	21.46
		12	12	21.27	21.56	21.31
		24	0	21.45	21.46	21.53
	16QAM	1	0	20.39	20.50	20.52
		1	12	20.16	20.36	20.42
		1	23	20.08	20.75	20.52
		12	0	20.35	20.26	20.22
		12	6	20.22	20.07	20.11
		12	12	20.39	20.17	20.47
		24	0	20.06	20.52	20.21
	64QAM	1	0	19.63	19.18	19.26
		1	12	19.17	19.22	19.51
		1	23	19.13	19.38	19.05
		12	0	19.38	19.06	19.28
		12	6	19.57	19.19	19.06
		12	12	19.61	19.27	19.20
		24	0	19.35	19.26	19.09
	256QAM	1	0	18.38	18.36	18.51
		1	12	18.58	18.48	18.24
1		23	18.74	18.63	18.56	
12		0	18.30	18.33	18.73	
12		6	18.29	18.86	18.69	
12		12	18.25	18.49	18.49	
24		0	18.25	18.77	18.69	

- n78

NR Band 78 (SCS 30kHz)				Average Output Power (dBm)		
BW	MCS Index	RB Size	RB Offset	Low	Mid	High
		Channel		623334	636666	650000
		Frequency (MHz)		3350.01	3549.99	3750
100 MHz	pi/2 BPSK	1	0	22.69	22.90	22.69
		1	136	22.49	22.15	22.81
		1	272	22.25	22.61	22.88
		136	0	22.37	22.54	22.49
		136	68	22.21	22.75	22.62
		136	136	22.26	22.62	22.40
		273	0	22.76	22.65	22.86
	QPSK	1	0	21.33	21.08	21.09
		1	136	21.18	21.21	21.23
		1	272	21.54	21.09	21.56
		136	0	21.11	21.57	21.57
		136	68	21.17	21.49	21.21
		136	136	21.32	21.19	21.12
		273	0	21.11	21.37	21.31
	16QAM	1	0	20.45	20.58	20.27
		1	136	20.06	20.73	20.54
		1	272	20.39	20.26	20.45
		136	0	20.24	20.46	20.29
		136	68	20.33	20.39	20.69
		136	136	20.44	20.75	20.13
		273	0	20.55	20.17	20.54
	64QAM	1	0	19.60	19.58	19.06
		1	136	19.27	19.01	19.38
		1	272	19.16	19.30	19.10
		136	0	19.10	19.35	19.10
		136	68	19.30	19.03	19.11
		136	136	19.11	19.39	19.27
		273	0	19.62	19.29	19.24
	256QAM	1	0	18.39	18.33	18.50
		1	136	18.84	18.25	18.55
1		272	18.25	18.24	18.41	
136		0	18.77	18.79	18.69	
136		68	18.36	18.35	18.33	
136		136	18.85	18.82	18.51	
273		0	18.63	18.54	18.58	

NR Band 78 (SCS 30kHz)				Average Output Power (dBm)		
BW	MCS Index	RB Size	RB Offset	Low	Mid	High
		Channel		623000	636666	650332
		Frequency (MHz)		3345	3549.99	3754.98
90 MHz	pi/2 BPSK	1	0	22.84	22.19	22.69
		1	122	22.09	22.42	22.80
		1	244	22.37	22.41	22.31
		122	0	22.47	22.56	22.62
		122	61	22.54	22.77	22.47
		122	122	22.54	22.60	22.50
		245	0	22.04	22.54	22.83
	QPSK	1	0	21.38	21.11	21.07
		1	122	21.42	21.08	21.30
		1	244	21.41	21.08	21.17
		122	0	21.43	21.40	21.29
		122	61	21.47	21.33	21.47
		122	122	21.27	21.31	21.24
		245	0	21.50	21.46	21.03
	16QAM	1	0	20.50	20.50	20.31
		1	122	20.11	20.25	20.49
		1	244	20.28	20.26	20.61
		122	0	20.16	20.21	20.11
		122	61	20.43	20.32	20.56
		122	122	20.13	20.04	20.70
		245	0	20.66	20.07	20.48
	64QAM	1	0	19.54	19.23	19.24
		1	122	19.55	19.44	19.28
		1	244	19.32	19.04	19.21
		122	0	19.20	19.56	19.53
		122	61	19.30	19.20	19.43
		122	122	19.40	19.54	19.54
		245	0	19.19	19.48	19.46
	256QAM	1	0	18.79	18.33	18.71
		1	122	18.83	18.69	18.53
1		244	18.56	18.67	18.80	
122		0	18.88	18.69	18.48	
122		61	18.89	18.40	18.62	
122		122	18.62	18.45	18.77	
245		0	18.59	18.71	18.33	

NR Band 78 (SCS 30kHz)				Average Output Power (dBm)		
BW	MCS Index	RB Size	RB Offset	Low	Mid	High
		Channel		622668	636666	650666
		Frequency (MHz)		3340.02	3549.99	3759.99
80 MHz	pi/2 BPSK	1	0	22.31	22.73	22.58
		1	108	22.55	22.47	22.31
		1	216	22.33	22.81	22.22
		108	0	22.75	22.69	22.61
		108	54	22.55	22.39	22.39
		108	108	22.77	22.65	22.75
		217	0	22.81	22.39	22.20
	QPSK	1	0	21.35	21.20	21.44
		1	108	21.30	21.02	21.19
		1	216	21.53	21.24	21.04
		108	0	21.31	21.24	21.20
		108	54	21.27	21.48	20.98
		108	108	21.45	21.11	21.30
		217	0	21.35	21.58	21.01
	16QAM	1	0	20.13	20.28	20.31
		1	108	20.12	20.34	20.59
		1	216	20.59	20.46	20.61
		108	0	20.37	20.07	20.14
		108	54	20.51	20.06	20.14
		108	108	20.44	20.17	20.61
		217	0	20.23	20.41	20.16
	64QAM	1	0	19.25	19.13	19.19
		1	108	19.13	19.31	19.21
		1	216	19.21	19.59	19.58
		108	0	19.34	19.12	19.37
		108	54	19.67	19.31	19.16
		108	108	19.33	19.08	19.63
		217	0	19.42	19.09	19.45
	256QAM	1	0	18.37	18.23	18.40
		1	108	18.22	18.57	18.52
1		216	18.51	18.87	18.80	
108		0	18.75	18.58	18.67	
108		54	18.25	18.62	18.65	
108		108	18.28	18.46	18.76	
217		0	18.37	18.83	18.69	

NR Band 78 (SCS 30kHz)				Average Output Power (dBm)		
BW	MCS Index	RB Size	RB Offset	Low	Mid	High
		Channel		622000	636666	651332
		Frequency (MHz)		3330	3549.99	3769.98
60 MHz	pi/2 BPSK	1	0	22.27	22.22	22.48
		1	81	22.37	22.51	22.29
		1	161	22.50	22.13	22.63
		81	0	22.09	22.15	22.68
		81	40	22.87	22.61	22.87
		81	81	22.56	22.10	22.80
		162	0	22.19	22.82	22.87
	QPSK	1	0	21.23	21.22	21.44
		1	81	21.51	21.58	20.97
		1	161	21.15	21.10	21.44
		81	0	21.21	21.53	21.19
		81	40	21.21	21.13	21.20
		81	81	21.26	21.45	21.53
		162	0	21.35	21.50	21.46
	16QAM	1	0	20.30	20.61	20.69
		1	81	20.15	20.09	20.20
		1	161	20.53	20.13	20.26
		81	0	20.44	20.61	20.45
		81	40	20.09	20.68	20.55
		81	81	20.12	20.22	20.64
		162	0	20.14	20.08	20.29
	64QAM	1	0	19.16	19.38	19.26
		1	81	19.41	19.01	19.67
		1	161	19.11	19.32	19.61
		81	0	19.44	19.41	19.38
		81	40	19.50	19.29	19.05
		81	81	19.13	19.05	19.07
		162	0	19.33	19.38	19.61
256QAM	1	0	18.61	18.57	18.27	
	1	81	18.29	18.77	18.23	
	1	161	18.83	18.54	18.35	
	81	0	18.67	18.39	18.48	
	81	40	18.77	18.55	18.83	
	81	81	18.44	18.32	18.67	
	162	0	18.72	18.82	18.53	

NR Band 78 (SCS 30kHz)				Average Output Power (dBm)		
BW	MCS Index	RB Size	RB Offset	Low	Mid	High
		Channel		621668	636666	651666
		Frequency (MHz)		3325.02	3549.99	3774.99
50 MHz	pi/2 BPSK	1	0	22.78	22.24	22.69
		1	66	22.80	22.42	22.76
		1	132	22.07	22.61	22.47
		66	0	22.79	22.61	22.26
		66	33	22.21	22.77	22.52
		66	66	22.13	22.77	22.80
		133	0	22.06	22.21	22.73
	QPSK	1	0	21.22	21.07	21.06
		1	66	21.14	21.12	21.54
		1	132	21.47	21.32	21.54
		66	0	21.24	21.12	21.22
		66	33	21.42	21.36	21.04
		66	66	21.55	21.59	21.47
		133	0	21.49	21.06	21.40
	16QAM	1	0	20.40	20.60	20.48
		1	66	20.36	20.63	20.22
		1	132	20.21	20.61	20.67
		66	0	20.33	20.76	20.52
		66	33	20.20	20.22	20.65
		66	66	20.19	20.54	20.53
		133	0	20.38	20.02	20.14
	64QAM	1	0	19.67	19.45	19.40
		1	66	19.61	19.60	19.05
		1	132	19.53	19.15	19.31
		66	0	19.15	19.29	19.63
		66	33	19.66	19.01	19.50
		66	66	19.13	19.55	19.21
		133	0	19.20	19.58	19.52
	256QAM	1	0	18.80	18.59	18.25
		1	66	18.72	18.59	18.36
1		132	18.63	18.76	18.30	
66		0	18.67	18.83	18.67	
66		33	18.44	18.71	18.40	
66		66	18.80	18.34	18.57	
133		0	18.24	18.54	18.79	

NR Band 78 (SCS 30kHz)				Average Output Power (dBm)		
BW	MCS Index	RB Size	RB Offset	Low	Mid	High
		Channel		621334	636666	652000
		Frequency (MHz)		3320.01	3549.99	3780
40 MHz	pi/2 BPSK	1	0	22.37	22.12	22.46
		1	53	22.41	22.29	22.85
		1	105	22.09	22.37	22.63
		53	0	22.31	22.21	22.42
		53	26	22.48	22.23	22.75
		53	53	22.49	22.51	22.55
		106	0	22.13	22.51	22.52
	QPSK	1	0	21.18	21.36	21.13
		1	53	21.25	21.28	21.08
		1	105	21.23	21.11	21.12
		53	0	21.39	21.30	21.28
		53	26	21.49	21.47	21.10
		53	53	21.35	21.00	21.42
		106	0	21.29	21.26	21.42
	16QAM	1	0	20.58	20.41	20.56
		1	53	20.51	20.04	20.55
		1	105	20.60	20.11	20.16
		53	0	20.52	20.29	20.69
		53	26	20.66	20.14	20.22
		53	53	20.32	20.33	20.14
		106	0	20.57	20.48	20.44
	64QAM	1	0	19.60	19.49	19.49
		1	53	19.11	19.04	19.48
		1	105	19.32	19.41	19.55
		53	0	19.14	19.42	19.53
		53	26	19.52	19.54	19.14
		53	53	19.55	19.11	19.65
		106	0	19.18	19.05	19.46
256QAM	1	0	18.83	18.26	18.83	
	1	53	18.69	18.76	18.27	
	1	105	18.33	18.25	18.56	
	53	0	18.41	18.74	18.62	
	53	26	18.67	18.35	18.57	
	53	53	18.68	18.28	18.30	
	106	0	18.23	18.82	18.74	

NR Band 78 (SCS 30kHz)				Average Output Power (dBm)		
BW	MCS Index	RB Size	RB Offset	Low	Mid	High
		Channel		620668	636666	652666
		Frequency (MHz)		3310.02	3549.99	3789.99
20 MHz	pi/2 BPSK	1	0	22.74	22.14	22.33
		1	25	22.86	22.46	22.35
		1	50	22.21	22.35	22.70
		25	0	22.22	22.61	22.89
		25	12	22.22	22.48	22.73
		25	25	22.09	22.61	22.24
		51	0	22.48	22.70	22.67
	QPSK	1	0	21.55	21.08	21.12
		1	25	21.53	21.12	21.39
		1	50	21.20	21.24	21.35
		25	0	21.32	21.35	21.19
		25	12	21.33	21.17	21.03
		25	25	21.39	21.17	21.45
		51	0	21.13	21.52	21.53
	16QAM	1	0	20.18	20.11	20.35
		1	25	20.12	20.30	20.49
		1	50	20.48	20.51	20.25
		25	0	20.06	20.76	20.68
		25	12	20.41	20.54	20.39
		25	25	20.11	20.13	20.32
		51	0	20.50	20.16	20.48
	64QAM	1	0	19.13	19.17	19.40
		1	25	19.39	19.52	19.45
		1	50	19.21	19.54	19.67
		25	0	19.54	19.59	19.60
		25	12	19.13	19.24	19.39
		25	25	19.39	19.10	19.67
		51	0	19.57	19.42	19.42
256QAM	1	0	18.70	18.65	18.22	
	1	25	18.37	18.71	18.45	
	1	50	18.42	18.24	18.40	
	25	0	18.22	18.37	18.62	
	25	12	18.26	18.59	18.66	
	25	25	18.86	18.62	18.57	
	51	0	18.72	18.50	18.61	

NR Band 78 (SCS 30kHz)				Average Output Power (dBm)		
BW	MCS Index	RB Size	RB Offset	Low	Mid	High
		Channel		620500	636666	652832
		Frequency (MHz)		3307.5	3549.99	3792.48
15 MHz	pi/2 BPSK	1	0	22.80	22.19	22.61
		1	19	22.24	22.54	22.46
		1	37	22.74	22.69	22.53
		19	0	22.63	22.35	22.86
		19	9	22.59	22.37	22.54
		19	20	22.61	22.42	22.15
		38	0	22.44	22.38	22.89
	QPSK	1	0	21.31	21.26	21.51
		1	19	21.51	21.43	21.57
		1	37	21.34	21.41	21.56
		19	0	21.50	21.58	21.37
		19	9	21.28	21.01	21.10
		19	20	21.38	21.58	21.12
		38	0	21.26	21.24	20.98
	16QAM	1	0	20.22	20.49	20.17
		1	19	20.10	20.52	20.52
		1	37	20.54	20.37	20.64
		19	0	20.29	20.71	20.36
		19	9	20.06	20.22	20.59
		19	20	20.23	20.42	20.69
		38	0	20.42	20.31	20.56
	64QAM	1	0	19.35	19.55	19.34
		1	19	19.50	19.56	19.12
		1	37	19.49	19.21	19.33
		19	0	19.64	19.35	19.48
		19	9	19.57	19.36	19.37
		19	20	19.11	19.19	19.59
		38	0	19.49	19.17	19.06
256QAM	1	0	18.73	18.65	18.75	
	1	19	18.29	18.79	18.29	
	1	37	18.30	18.78	18.38	
	19	0	18.54	18.38	18.62	
	19	9	18.50	18.53	18.44	
	19	20	18.50	18.44	18.81	
	38	0	18.25	18.71	18.50	

NR Band 78 (SCS 30kHz)				Average Output Power (dBm)		
BW	MCS Index	RB Size	RB Offset	Low	Mid	High
		Channel		620334	636666	653000
		Frequency (MHz)		3305.01	3549.99	3795
10 MHz	pi/2 BPSK	1	0	22.03	22.78	22.36
		1	12	22.06	22.61	22.55
		1	23	22.72	22.41	22.68
		12	0	22.05	22.74	22.22
		12	6	22.01	22.21	22.44
		12	12	22.01	22.35	22.38
		24	0	22.65	22.80	22.23
	QPSK	1	0	21.36	21.31	21.25
		1	12	21.54	21.43	21.05
		1	23	21.35	21.19	21.21
		12	0	21.10	21.13	21.33
		12	6	21.30	21.58	21.50
		12	12	21.49	21.59	21.38
		24	0	21.33	21.58	20.99
	16QAM	1	0	20.52	20.26	20.25
		1	12	20.09	20.72	20.34
		1	23	20.14	20.30	20.34
		12	0	20.17	20.53	20.57
		12	6	20.06	20.29	20.42
		12	12	20.28	20.53	20.26
		24	0	20.65	20.04	20.51
	64QAM	1	0	19.12	19.40	19.16
		1	12	19.59	19.05	19.60
		1	23	19.21	19.48	19.29
		12	0	19.54	19.38	19.22
		12	6	19.38	19.24	19.48
		12	12	19.22	19.37	19.67
		24	0	19.62	19.26	19.15
	256QAM	1	0	18.25	18.55	18.77
		1	12	18.44	18.39	18.57
1		23	18.38	18.37	18.77	
12		0	18.25	18.49	18.61	
12		6	18.26	18.43	18.73	
12		12	18.29	18.45	18.59	
24		0	18.87	18.40	18.41	

2.3. DSDA2 port: Int Bua antenna (TCU internal)

2.3.1. LTE Bands

- LTE 42

Band	BW	Modulation	Mode	MPR	Average Output Power (dBm)		
					Low CH	Mid CH	High CH
					3410.0 MHz	3500.0 MHz	3590.0 MHz
LTE B42	20 MHz	QPSK	1RB Low	0	23.38	22.32	22.59
			1RB Mid	0	23.12	22.41	22.36
			1RB High	0	23.16	22.67	22.19
			50% Low	1	22.31	21.32	21.42
			50% Mid	1	22.25	21.39	21.32
			50% High	1	22.19	21.48	21.21
			100%	1	22.25	21.41	21.33
		16-QAM	1RB Low	1	22.30	21.49	21.73
			1RB Mid	1	22.26	21.37	21.12
			1RB High	1	22.27	21.55	21.19
			50% Low	2	21.32	20.27	20.50
			50% Mid	2	21.28	20.39	20.31
			50% High	2	21.22	20.47	20.21
			100%	2	21.22	20.37	20.34
Band	BW	Modulation	Mode	MPR	Low CH	Mid CH	High CH
					3407.5 MHz	3500.0 MHz	3592.5 MHz
LTE B42	15 MHz	QPSK	1RB Low	0	23.34	22.35	22.38
			1RB Mid	0	23.59	22.58	22.05
			1RB High	0	23.19	22.63	22.14
			50% Low	1	22.37	21.38	21.40
			50% Mid	1	22.35	21.43	21.31
			50% High	1	22.30	21.52	21.28
			100%	1	22.40	21.48	21.40
		16-QAM	1RB Low	1	22.22	21.17	21.56
			1RB Mid	1	22.58	21.33	21.39
			1RB High	1	22.26	21.61	21.39
			50% Low	2	21.42	20.32	20.40
			50% Mid	2	21.30	20.38	20.22
			50% High	2	21.27	20.52	20.20
			100%	2	21.32	20.40	20.28

Band	BW	Modulation	Mode	MPR	Average Output Power (dBm)		
					Low CH	Mid CH	High CH
					3405.0 MHz	3500.0 MHz	3595.0 MHz
LTE B42	10 MHz	QPSK	1RB Low	0	23.34	22.33	22.29
			1RB Mid	0	23.25	22.07	22.11
			1RB High	0	23.32	22.49	22.10
			50% Low	1	22.34	21.35	21.27
			50% Mid	1	22.29	21.34	21.17
			50% High	1	22.31	21.41	21.19
			100%	1	22.35	21.32	21.24
		16-QAM	1RB Low	1	22.52	21.42	21.32
			1RB Mid	1	22.37	21.01	21.51
			1RB High	1	22.63	21.34	21.44
			50% Low	2	21.28	20.32	20.29
			50% Mid	2	21.31	20.38	20.14
			50% High	2	21.33	20.45	20.11
			100%	2	21.34	20.35	20.21
Band	BW	Modulation	Mode	MPR	Low CH	Mid CH	High CH
					3402.5 MHz	3500.0 MHz	3597.5 MHz
LTE B42	5 MHz	QPSK	1RB Low	0	23.31	22.36	22.27
			1RB Mid	0	23.51	22.55	22.08
			1RB High	0	23.31	22.39	22.18
			50% Low	1	22.34	21.37	21.15
			50% Mid	1	22.32	21.35	21.09
			50% High	1	22.33	21.37	21.16
			100%	1	22.33	21.35	21.15
		16-QAM	1RB Low	1	22.29	20.97	21.14
			1RB Mid	1	22.98	21.60	21.11
			1RB High	1	22.71	21.63	21.15
			50% Low	2	21.34	20.40	20.21
			50% Mid	2	21.30	20.37	20.12
			50% High	2	21.22	20.40	20.16
			100%	2	21.32	20.41	20.10

2.3.2. 5G Bands

- n77

NR Band 77 (SCS 30kHz)				Average Output Power (dBm)		
BW	MCS Index	RB Size	RB Offset	Low	Mid	High
		Channel		623334	650000	676666
		Frequency (MHz)		3350.01	3750	4149.99
100 MHz	pi/2 BPSK	1	0	21.91	22.87	22.25
		1	136	22.04	22.66	22.22
		1	272	22.25	22.17	22.21
		136	0	22.25	22.82	22.15
		136	68	22.10	22.02	22.13
		136	136	21.95	22.79	22.33
		273	0	22.17	22.13	22.33
	QPSK	1	0	21.12	21.14	21.01
		1	136	21.45	21.31	21.30
		1	272	21.19	21.10	21.55
		136	0	21.20	21.43	20.98
		136	68	21.37	21.25	21.27
		136	136	21.31	21.39	21.16
		273	0	21.45	21.28	21.34
	16QAM	1	0	20.18	20.15	20.23
		1	136	20.30	20.12	20.70
		1	272	20.54	20.20	20.57
		136	0	20.41	20.02	20.62
		136	68	20.28	20.39	20.64
		136	136	20.55	20.17	20.37
		273	0	20.29	20.56	20.48
	64QAM	1	0	19.43	19.13	19.18
		1	136	19.65	19.14	19.29
		1	272	19.28	19.26	19.55
		136	0	19.35	19.18	19.58
		136	68	19.42	19.18	19.31
		136	136	19.24	19.26	19.30
		273	0	19.43	19.15	19.33
	256QAM	1	0	18.33	18.60	18.60
		1	136	18.39	18.64	18.41
		1	272	18.72	18.64	18.27
		136	0	18.83	18.78	18.37
		136	68	18.26	18.43	18.27
		136	136	18.34	18.27	18.57
		273	0	18.22	18.59	18.33

NR Band 77 (SCS 30kHz)				Average Output Power (dBm)		
BW	MCS Index	RB Size	RB Offset	Low	Mid	High
		Channel		623000	650000	67700
		Frequency (MHz)		3345	3750	4155
90 MHz	pi/2 BPSK	1	0	21.99	22.20	21.98
		1	122	21.94	22.39	22.07
		1	244	22.37	22.08	22.01
		122	0	22.28	22.74	22.28
		122	61	22.37	22.45	22.27
		122	122	22.38	22.31	22.06
		245	0	22.14	22.01	22.27
	QPSK	1	0	21.31	21.56	21.17
		1	122	21.31	21.28	21.11
		1	244	21.44	21.44	21.13
		122	0	21.18	21.26	21.09
		122	61	21.50	21.60	21.23
		122	122	21.17	21.34	21.32
		245	0	21.39	21.21	21.39
	16QAM	1	0	20.54	20.46	20.46
		1	122	20.51	20.12	20.28
		1	244	20.52	20.68	20.58
		122	0	20.51	20.38	20.17
		122	61	20.35	20.44	20.62
		122	122	20.32	20.32	20.43
		245	0	20.14	20.21	20.62
	64QAM	1	0	19.45	19.58	19.69
		1	122	19.36	19.01	19.52
		1	244	19.20	19.33	19.09
		122	0	19.62	19.26	19.65
		122	61	19.62	19.08	19.69
		122	122	19.23	19.55	19.61
		245	0	19.66	19.43	19.56
	256QAM	1	0	18.65	18.36	18.84
		1	122	18.74	18.34	18.26
1		244	18.80	18.69	18.80	
122		0	18.42	18.72	18.89	
122		61	18.66	18.23	18.51	
122		122	18.86	18.31	18.77	
245		0	18.32	18.65	18.84	

NR Band 77 (SCS 30kHz)				Average Output Power (dBm)		
BW	MCS Index	RB Size	RB Offset	Low	Mid	High
		Channel		622668	650000	677332
		Frequency (MHz)		3340.02	3750	4159.98
80 MHz	pi/2 BPSK	1	0	22.08	22.57	22.07
		1	108	22.14	22.72	22.32
		1	216	22.04	22.09	22.08
		108	0	22.14	21.99	22.38
		108	54	22.37	22.03	22.38
		108	108	22.24	22.30	22.00
		217	0	22.00	22.39	21.99
	QPSK	1	0	21.32	21.60	21.49
		1	108	21.25	21.56	21.00
		1	216	21.52	21.19	21.34
		108	0	21.41	21.32	21.23
		108	54	21.46	21.20	21.34
		108	108	21.51	21.33	20.96
		217	0	21.23	21.37	21.09
	16QAM	1	0	20.37	20.15	20.48
		1	108	20.56	20.05	20.16
		1	216	20.63	20.05	20.54
		108	0	20.39	20.47	20.40
		108	54	20.24	20.44	20.64
		108	108	20.09	20.38	20.10
		217	0	20.07	20.19	20.68
	64QAM	1	0	19.21	19.40	19.33
		1	108	19.37	19.41	19.32
		1	216	19.50	19.07	19.36
		108	0	19.64	19.30	19.42
		108	54	19.46	19.44	19.67
		108	108	19.21	19.02	19.15
		217	0	19.48	19.25	19.12
	256QAM	1	0	18.48	18.83	18.32
		1	108	18.56	18.76	18.67
		1	216	18.55	18.67	18.59
		108	0	18.82	18.55	18.81
		108	54	18.86	18.55	18.87
		108	108	18.59	18.88	18.48
		217	0	18.60	18.82	18.78

NR Band 77 (SCS 30kHz)				Average Output Power (dBm)		
BW	MCS Index	RB Size	RB Offset	Low	Mid	High
		Channel		622000	650000	678000
		Frequency (MHz)		3330	3750	4170
60 MHz	pi/2 BPSK	1	0	22.37	22.48	21.97
		1	81	22.33	22.31	22.03
		1	161	22.29	22.76	22.38
		81	0	22.00	22.03	22.24
		81	40	22.25	22.03	22.32
		81	81	22.27	22.49	22.35
		162	0	22.41	22.32	21.97
	QPSK	1	0	21.21	21.34	21.40
		1	81	21.18	21.35	21.16
		1	161	21.29	21.38	21.25
		81	0	21.50	21.27	21.18
		81	40	21.40	21.07	21.34
		81	81	21.36	21.55	21.33
		162	0	21.54	21.38	21.42
	16QAM	1	0	20.22	20.42	20.68
		1	81	20.16	20.28	20.15
		1	161	20.32	20.45	20.31
		81	0	20.25	20.32	20.51
		81	40	20.55	20.01	20.47
		81	81	20.08	20.55	20.43
		162	0	20.37	20.15	20.53
	64QAM	1	0	19.49	19.45	19.15
		1	81	19.27	19.25	19.34
		1	161	19.56	19.34	19.27
		81	0	19.58	19.10	19.43
		81	40	19.12	19.57	19.06
		81	81	19.33	19.10	19.42
		162	0	19.23	19.56	19.57
	256QAM	1	0	18.45	18.26	18.75
		1	81	18.27	18.47	18.64
1		161	18.71	18.42	18.41	
81		0	18.36	18.26	18.40	
81		40	18.67	18.42	18.61	
81		81	18.35	18.76	18.23	
162		0	18.21	18.40	18.23	

NR Band 77 (SCS 30kHz)				Average Output Power (dBm)		
BW	MCS Index	RB Size	RB Offset	Low	Mid	High
		Channel		621668	650000	678332
		Frequency (MHz)		3325.02	3750	4174.98
50 MHz	pi/2 BPSK	1	0	22.07	22.46	22.37
		1	66	22.04	22.39	22.37
		1	132	22.13	22.06	22.07
		66	0	22.17	22.54	22.27
		66	33	22.37	22.26	21.97
		66	66	22.07	22.70	22.17
		133	0	22.37	22.45	22.24
	QPSK	1	0	21.54	21.27	21.10
		1	66	21.47	21.13	21.07
		1	132	21.13	21.24	21.05
		66	0	21.36	21.31	21.55
		66	33	21.47	21.32	21.56
		66	66	21.22	21.40	21.43
		133	0	21.54	21.32	20.96
	16QAM	1	0	20.56	20.72	20.62
		1	66	20.16	20.68	20.38
		1	132	20.35	20.76	20.12
		66	0	20.50	20.24	20.44
		66	33	20.46	20.68	20.47
		66	66	20.49	20.02	20.22
		133	0	20.31	20.19	20.64
	64QAM	1	0	19.65	19.53	19.69
		1	66	19.51	19.21	19.42
		1	132	19.26	19.03	19.22
		66	0	19.30	19.12	19.35
		66	33	19.53	19.35	19.64
		66	66	19.14	19.05	19.64
		133	0	19.67	19.01	19.41
	256QAM	1	0	18.78	18.50	18.27
		1	66	18.64	18.78	18.75
1		132	18.78	18.78	18.82	
66		0	18.80	18.70	18.51	
66		33	18.49	18.53	18.67	
66		66	18.47	18.37	18.87	
133		0	18.73	18.72	18.85	

NR Band 77 (SCS 30kHz)				Average Output Power (dBm)		
BW	MCS Index	RB Size	RB Offset	Low	Mid	High
		Channel		621334	650000	678666
		Frequency (MHz)		3320.01	3750	4179.99
40 MHz	pi/2 BPSK	1	0	22.38	22.53	22.29
		1	53	22.27	22.40	22.02
		1	105	22.47	22.54	22.20
		53	0	22.19	22.56	22.12
		53	26	22.01	22.24	22.26
		53	53	21.99	22.21	22.14
		106	0	21.93	22.07	22.31
	QPSK	1	0	21.13	21.15	21.59
		1	53	21.34	21.20	21.17
		1	105	21.39	21.58	21.04
		53	0	21.14	21.43	21.53
		53	26	21.18	21.16	21.48
		53	53	21.25	21.51	21.57
		106	0	21.41	21.53	21.04
	16QAM	1	0	20.22	20.52	20.37
		1	53	20.52	20.19	20.46
		1	105	20.37	20.06	20.49
		53	0	20.11	20.09	20.16
		53	26	20.19	20.59	20.69
		53	53	20.06	20.74	20.32
		106	0	20.43	20.62	20.43
	64QAM	1	0	19.13	19.14	19.11
		1	53	19.35	19.40	19.66
		1	105	19.55	19.24	19.68
		53	0	19.11	19.36	19.54
		53	26	19.60	19.35	19.47
		53	53	19.16	19.54	19.19
		106	0	19.61	19.58	19.19
	256QAM	1	0	18.73	18.76	18.24
		1	53	18.89	18.82	18.34
1		105	18.33	18.73	18.67	
53		0	18.70	18.83	18.22	
53		26	18.72	18.56	18.61	
53		53	18.48	18.75	18.79	
106		0	18.24	18.33	18.67	

NR Band 77 (SCS 30kHz)				Average Output Power (dBm)		
BW	MCS Index	RB Size	RB Offset	Low	Mid	High
		Channel		620668	650000	679332
		Frequency (MHz)		3310.02	3750	4189.98
20 MHz	pi/2 BPSK	1	0	22.39	22.19	22.30
		1	25	22.18	22.39	22.36
		1	50	22.10	22.34	22.04
		25	0	22.15	22.46	21.97
		25	12	21.93	22.03	22.03
		25	25	22.27	22.85	22.29
		51	0	22.25	22.47	22.18
	QPSK	1	0	21.54	21.02	20.98
		1	25	21.49	21.13	21.34
		1	50	21.44	21.03	21.49
		25	0	21.49	21.16	21.49
		25	12	21.17	21.43	21.18
		25	25	21.46	21.10	21.01
		51	0	21.47	21.46	21.37
	16QAM	1	0	20.57	20.17	20.47
		1	25	20.25	20.19	20.48
		1	50	20.06	20.78	20.13
		25	0	20.63	20.58	20.12
		25	12	20.53	20.51	20.47
		25	25	20.08	20.21	20.53
		51	0	20.05	20.23	20.17
	64QAM	1	0	19.18	19.13	19.14
		1	25	19.48	19.54	19.15
		1	50	19.17	19.00	19.05
		25	0	19.53	19.48	19.39
		25	12	19.61	19.43	19.48
		25	25	19.68	19.20	19.29
		51	0	19.13	19.56	19.66
	256QAM	1	0	18.69	18.69	18.89
		1	25	18.36	18.47	18.72
1		50	18.24	18.58	18.36	
25		0	18.28	18.55	18.23	
25		12	18.60	18.31	18.33	
25		25	18.66	18.36	18.35	
51		0	18.81	18.55	18.73	

NR Band 77 (SCS 30kHz)				Average Output Power (dBm)		
BW	MCS Index	RB Size	RB Offset	Low	Mid	High
		Channel		620500	650000	679500
		Frequency (MHz)		3307.5	3750	4192.5
15 MHz	pi/2 BPSK	1	0	21.91	22.49	22.31
		1	19	21.98	22.78	22.01
		1	37	22.24	22.27	22.23
		19	0	21.99	22.73	22.17
		19	9	22.41	22.31	22.26
		19	20	22.46	22.01	22.03
		38	0	22.37	22.53	22.35
	QPSK	1	0	21.53	21.35	21.26
		1	19	21.46	21.42	21.46
		1	37	21.21	21.29	20.99
		19	0	21.47	21.32	21.21
		19	9	21.24	21.07	21.11
		19	20	21.39	21.17	21.02
		38	0	21.25	21.37	21.55
	16QAM	1	0	20.48	20.67	20.55
		1	19	20.57	20.49	20.31
		1	37	20.51	20.77	20.66
		19	0	20.40	20.58	20.25
		19	9	20.62	20.53	20.49
		19	20	20.23	20.69	20.50
		38	0	20.19	20.67	20.63
	64QAM	1	0	19.44	19.06	19.39
		1	19	19.58	19.20	19.12
		1	37	19.45	19.30	19.70
		19	0	19.32	19.14	19.38
		19	9	19.27	19.04	19.17
		19	20	19.17	19.13	19.57
		38	0	19.29	19.27	19.40
256QAM	1	0	18.74	18.76	18.50	
	1	19	18.57	18.35	18.50	
	1	37	18.42	18.44	18.23	
	19	0	18.81	18.56	18.24	
	19	9	18.78	18.83	18.31	
	19	20	18.51	18.70	18.22	
	38	0	18.34	18.38	18.84	

NR Band 77 (SCS 30kHz)				Average Output Power (dBm)		
BW	MCS Index	RB Size	RB Offset	Low	Mid	High
		Channel		620334	650000	679666
		Frequency (MHz)		3305.01	3750	4194.99
10 MHz	pi/2 BPSK	1	0	22.06	22.68	22.35
		1	12	22.20	22.54	22.11
		1	23	22.32	22.63	22.16
		12	0	22.16	22.32	22.15
		12	6	22.38	22.21	22.28
		12	12	21.99	22.59	22.29
		24	0	22.04	22.43	22.17
	QPSK	1	0	21.26	21.43	21.39
		1	12	21.39	21.04	21.28
		1	23	21.35	21.21	21.50
		12	0	21.49	21.05	21.21
		12	6	21.36	21.39	21.46
		12	12	21.27	21.56	21.31
		24	0	21.45	21.46	21.53
	16QAM	1	0	20.39	20.50	20.52
		1	12	20.16	20.36	20.42
		1	23	20.08	20.75	20.52
		12	0	20.35	20.26	20.22
		12	6	20.22	20.07	20.11
		12	12	20.39	20.17	20.47
		24	0	20.06	20.52	20.21
	64QAM	1	0	19.63	19.18	19.26
		1	12	19.17	19.22	19.51
		1	23	19.13	19.38	19.05
		12	0	19.38	19.06	19.28
		12	6	19.57	19.19	19.06
		12	12	19.61	19.27	19.20
		24	0	19.35	19.26	19.09
256QAM	1	0	18.38	18.36	18.51	
	1	12	18.58	18.48	18.24	
	1	23	18.74	18.63	18.56	
	12	0	18.30	18.33	18.73	
	12	6	18.29	18.86	18.69	
	12	12	18.25	18.49	18.49	
	24	0	18.25	18.77	18.69	

- n78

NR Band 78 (SCS 30kHz)				Average Output Power (dBm)		
BW	MCS Index	RB Size	RB Offset	Low	Mid	High
		Channel		623334	636666	650000
		Frequency (MHz)		3350.01	3549.99	3750
100 MHz	pi/2 BPSK	1	0	22.69	22.90	22.69
		1	136	22.49	22.15	22.81
		1	272	22.25	22.61	22.88
		136	0	22.37	22.54	22.49
		136	68	22.21	22.75	22.62
		136	136	22.26	22.62	22.40
		273	0	22.76	22.65	22.86
	QPSK	1	0	21.33	21.08	21.09
		1	136	21.18	21.21	21.23
		1	272	21.54	21.09	21.56
		136	0	21.11	21.57	21.57
		136	68	21.17	21.49	21.21
		136	136	21.32	21.19	21.12
		273	0	21.11	21.37	21.31
	16QAM	1	0	20.45	20.58	20.27
		1	136	20.06	20.73	20.54
		1	272	20.39	20.26	20.45
		136	0	20.24	20.46	20.29
		136	68	20.33	20.39	20.69
		136	136	20.44	20.75	20.13
		273	0	20.55	20.17	20.54
	64QAM	1	0	19.60	19.58	19.06
		1	136	19.27	19.01	19.38
		1	272	19.16	19.30	19.10
		136	0	19.10	19.35	19.10
		136	68	19.30	19.03	19.11
		136	136	19.11	19.39	19.27
		273	0	19.62	19.29	19.24
	256QAM	1	0	18.39	18.33	18.50
		1	136	18.84	18.25	18.55
1		272	18.25	18.24	18.41	
136		0	18.77	18.79	18.69	
136		68	18.36	18.35	18.33	
136		136	18.85	18.82	18.51	
273		0	18.63	18.54	18.58	

NR Band 78 (SCS 30kHz)				Average Output Power (dBm)		
BW	MCS Index	RB Size	RB Offset	Low	Mid	High
		Channel		623000	636666	650332
		Frequency (MHz)		3345	3549.99	3754.98
90 MHz	pi/2 BPSK	1	0	22.84	22.19	22.69
		1	122	22.09	22.42	22.80
		1	244	22.37	22.41	22.31
		122	0	22.47	22.56	22.62
		122	61	22.54	22.77	22.47
		122	122	22.54	22.60	22.50
		245	0	22.04	22.54	22.83
	QPSK	1	0	21.38	21.11	21.07
		1	122	21.42	21.08	21.30
		1	244	21.41	21.08	21.17
		122	0	21.43	21.40	21.29
		122	61	21.47	21.33	21.47
		122	122	21.27	21.31	21.24
		245	0	21.50	21.46	21.03
	16QAM	1	0	20.50	20.50	20.31
		1	122	20.11	20.25	20.49
		1	244	20.28	20.26	20.61
		122	0	20.16	20.21	20.11
		122	61	20.43	20.32	20.56
		122	122	20.13	20.04	20.70
		245	0	20.66	20.07	20.48
	64QAM	1	0	19.54	19.23	19.24
		1	122	19.55	19.44	19.28
		1	244	19.32	19.04	19.21
		122	0	19.20	19.56	19.53
		122	61	19.30	19.20	19.43
		122	122	19.40	19.54	19.54
		245	0	19.19	19.48	19.46
	256QAM	1	0	18.79	18.33	18.71
		1	122	18.83	18.69	18.53
1		244	18.56	18.67	18.80	
122		0	18.88	18.69	18.48	
122		61	18.89	18.40	18.62	
122		122	18.62	18.45	18.77	
245		0	18.59	18.71	18.33	

NR Band 78 (SCS 30kHz)				Average Output Power (dBm)		
BW	MCS Index	RB Size	RB Offset	Low	Mid	High
		Channel		622668	636666	650666
		Frequency (MHz)		3340.02	3549.99	3759.99
80 MHz	pi/2 BPSK	1	0	22.31	22.73	22.58
		1	108	22.55	22.47	22.31
		1	216	22.33	22.81	22.22
		108	0	22.75	22.69	22.61
		108	54	22.55	22.39	22.39
		108	108	22.77	22.65	22.75
		217	0	22.81	22.39	22.20
	QPSK	1	0	21.35	21.20	21.44
		1	108	21.30	21.02	21.19
		1	216	21.53	21.24	21.04
		108	0	21.31	21.24	21.20
		108	54	21.27	21.48	20.98
		108	108	21.45	21.11	21.30
		217	0	21.35	21.58	21.01
	16QAM	1	0	20.13	20.28	20.31
		1	108	20.12	20.34	20.59
		1	216	20.59	20.46	20.61
		108	0	20.37	20.07	20.14
		108	54	20.51	20.06	20.14
		108	108	20.44	20.17	20.61
		217	0	20.23	20.41	20.16
	64QAM	1	0	19.25	19.13	19.19
		1	108	19.13	19.31	19.21
		1	216	19.21	19.59	19.58
		108	0	19.34	19.12	19.37
		108	54	19.67	19.31	19.16
		108	108	19.33	19.08	19.63
		217	0	19.42	19.09	19.45
256QAM	1	0	18.37	18.23	18.40	
	1	108	18.22	18.57	18.52	
	1	216	18.51	18.87	18.80	
	108	0	18.75	18.58	18.67	
	108	54	18.25	18.62	18.65	
	108	108	18.28	18.46	18.76	
	217	0	18.37	18.83	18.69	

NR Band 78 (SCS 30kHz)				Average Output Power (dBm)		
BW	MCS Index	RB Size	RB Offset	Low	Mid	High
		Channel		622000	636666	651332
		Frequency (MHz)		3330	3549.99	3769.98
60 MHz	pi/2 BPSK	1	0	22.27	22.22	22.48
		1	81	22.37	22.51	22.29
		1	161	22.50	22.13	22.63
		81	0	22.09	22.15	22.68
		81	40	22.87	22.61	22.87
		81	81	22.56	22.10	22.80
		162	0	22.19	22.82	22.87
	QPSK	1	0	21.23	21.22	21.44
		1	81	21.51	21.58	20.97
		1	161	21.15	21.10	21.44
		81	0	21.21	21.53	21.19
		81	40	21.21	21.13	21.20
		81	81	21.26	21.45	21.53
		162	0	21.35	21.50	21.46
	16QAM	1	0	20.30	20.61	20.69
		1	81	20.15	20.09	20.20
		1	161	20.53	20.13	20.26
		81	0	20.44	20.61	20.45
		81	40	20.09	20.68	20.55
		81	81	20.12	20.22	20.64
		162	0	20.14	20.08	20.29
	64QAM	1	0	19.16	19.38	19.26
		1	81	19.41	19.01	19.67
		1	161	19.11	19.32	19.61
		81	0	19.44	19.41	19.38
		81	40	19.50	19.29	19.05
		81	81	19.13	19.05	19.07
		162	0	19.33	19.38	19.61
	256QAM	1	0	18.61	18.57	18.27
		1	81	18.29	18.77	18.23
1		161	18.83	18.54	18.35	
81		0	18.67	18.39	18.48	
81		40	18.77	18.55	18.83	
81		81	18.44	18.32	18.67	
162		0	18.72	18.82	18.53	

NR Band 78 (SCS 30kHz)				Average Output Power (dBm)		
BW	MCS Index	RB Size	RB Offset	Low	Mid	High
		Channel		621668	636666	651666
		Frequency (MHz)		3325.02	3549.99	3774.99
50 MHz	pi/2 BPSK	1	0	22.78	22.24	22.69
		1	66	22.80	22.42	22.76
		1	132	22.07	22.61	22.47
		66	0	22.79	22.61	22.26
		66	33	22.21	22.77	22.52
		66	66	22.13	22.77	22.80
		133	0	22.06	22.21	22.73
	QPSK	1	0	21.22	21.07	21.06
		1	66	21.14	21.12	21.54
		1	132	21.47	21.32	21.54
		66	0	21.24	21.12	21.22
		66	33	21.42	21.36	21.04
		66	66	21.55	21.59	21.47
		133	0	21.49	21.06	21.40
	16QAM	1	0	20.40	20.60	20.48
		1	66	20.36	20.63	20.22
		1	132	20.21	20.61	20.67
		66	0	20.33	20.76	20.52
		66	33	20.20	20.22	20.65
		66	66	20.19	20.54	20.53
		133	0	20.38	20.02	20.14
	64QAM	1	0	19.67	19.45	19.40
		1	66	19.61	19.60	19.05
		1	132	19.53	19.15	19.31
		66	0	19.15	19.29	19.63
		66	33	19.66	19.01	19.50
		66	66	19.13	19.55	19.21
		133	0	19.20	19.58	19.52
	256QAM	1	0	18.80	18.59	18.25
		1	66	18.72	18.59	18.36
1		132	18.63	18.76	18.30	
66		0	18.67	18.83	18.67	
66		33	18.44	18.71	18.40	
66		66	18.80	18.34	18.57	
133		0	18.24	18.54	18.79	

NR Band 78 (SCS 30kHz)				Average Output Power (dBm)		
BW	MCS Index	RB Size	RB Offset	Low	Mid	High
		Channel		621334	636666	652000
		Frequency (MHz)		3320.01	3549.99	3780
40 MHz	pi/2 BPSK	1	0	22.37	22.12	22.46
		1	53	22.41	22.29	22.85
		1	105	22.09	22.37	22.63
		53	0	22.31	22.21	22.42
		53	26	22.48	22.23	22.75
		53	53	22.49	22.51	22.55
		106	0	22.13	22.51	22.52
	QPSK	1	0	21.18	21.36	21.13
		1	53	21.25	21.28	21.08
		1	105	21.23	21.11	21.12
		53	0	21.39	21.30	21.28
		53	26	21.49	21.47	21.10
		53	53	21.35	21.00	21.42
		106	0	21.29	21.26	21.42
	16QAM	1	0	20.58	20.41	20.56
		1	53	20.51	20.04	20.55
		1	105	20.60	20.11	20.16
		53	0	20.52	20.29	20.69
		53	26	20.66	20.14	20.22
		53	53	20.32	20.33	20.14
		106	0	20.57	20.48	20.44
	64QAM	1	0	19.60	19.49	19.49
		1	53	19.11	19.04	19.48
		1	105	19.32	19.41	19.55
		53	0	19.14	19.42	19.53
		53	26	19.52	19.54	19.14
		53	53	19.55	19.11	19.65
		106	0	19.18	19.05	19.46
256QAM	1	0	18.83	18.26	18.83	
	1	53	18.69	18.76	18.27	
	1	105	18.33	18.25	18.56	
	53	0	18.41	18.74	18.62	
	53	26	18.67	18.35	18.57	
	53	53	18.68	18.28	18.30	
	106	0	18.23	18.82	18.74	

NR Band 78 (SCS 30kHz)				Average Output Power (dBm)		
BW	MCS Index	RB Size	RB Offset	Low	Mid	High
		Channel		620668	636666	652666
		Frequency (MHz)		3310.02	3549.99	3789.99
20 MHz	pi/2 BPSK	1	0	22.74	22.14	22.33
		1	25	22.86	22.46	22.35
		1	50	22.21	22.35	22.70
		25	0	22.22	22.61	22.89
		25	12	22.22	22.48	22.73
		25	25	22.09	22.61	22.24
		51	0	22.48	22.70	22.67
	QPSK	1	0	21.55	21.08	21.12
		1	25	21.53	21.12	21.39
		1	50	21.20	21.24	21.35
		25	0	21.32	21.35	21.19
		25	12	21.33	21.17	21.03
		25	25	21.39	21.17	21.45
		51	0	21.13	21.52	21.53
	16QAM	1	0	20.18	20.11	20.35
		1	25	20.12	20.30	20.49
		1	50	20.48	20.51	20.25
		25	0	20.06	20.76	20.68
		25	12	20.41	20.54	20.39
		25	25	20.11	20.13	20.32
		51	0	20.50	20.16	20.48
	64QAM	1	0	19.13	19.17	19.40
		1	25	19.39	19.52	19.45
		1	50	19.21	19.54	19.67
		25	0	19.54	19.59	19.60
		25	12	19.13	19.24	19.39
		25	25	19.39	19.10	19.67
		51	0	19.57	19.42	19.42
256QAM	1	0	18.70	18.65	18.22	
	1	25	18.37	18.71	18.45	
	1	50	18.42	18.24	18.40	
	25	0	18.22	18.37	18.62	
	25	12	18.26	18.59	18.66	
	25	25	18.86	18.62	18.57	
	51	0	18.72	18.50	18.61	

NR Band 78 (SCS 30kHz)				Average Output Power (dBm)		
BW	MCS Index	RB Size	RB Offset	Low	Mid	High
		Channel		620500	636666	652832
		Frequency (MHz)		3307.5	3549.99	3792.48
15 MHz	pi/2 BPSK	1	0	22.80	22.19	22.61
		1	19	22.24	22.54	22.46
		1	37	22.74	22.69	22.53
		19	0	22.63	22.35	22.86
		19	9	22.59	22.37	22.54
		19	20	22.61	22.42	22.15
		38	0	22.44	22.38	22.89
	QPSK	1	0	21.31	21.26	21.51
		1	19	21.51	21.43	21.57
		1	37	21.34	21.41	21.56
		19	0	21.50	21.58	21.37
		19	9	21.28	21.01	21.10
		19	20	21.38	21.58	21.12
		38	0	21.26	21.24	20.98
	16QAM	1	0	20.22	20.49	20.17
		1	19	20.10	20.52	20.52
		1	37	20.54	20.37	20.64
		19	0	20.29	20.71	20.36
		19	9	20.06	20.22	20.59
		19	20	20.23	20.42	20.69
		38	0	20.42	20.31	20.56
	64QAM	1	0	19.35	19.55	19.34
		1	19	19.50	19.56	19.12
		1	37	19.49	19.21	19.33
		19	0	19.64	19.35	19.48
		19	9	19.57	19.36	19.37
		19	20	19.11	19.19	19.59
		38	0	19.49	19.17	19.06
	256QAM	1	0	18.73	18.65	18.75
		1	19	18.29	18.79	18.29
1		37	18.30	18.78	18.38	
19		0	18.54	18.38	18.62	
19		9	18.50	18.53	18.44	
19		20	18.50	18.44	18.81	
38		0	18.25	18.71	18.50	

NR Band 78 (SCS 30kHz)				Average Output Power (dBm)		
BW	MCS Index	RB Size	RB Offset	Low	Mid	High
		Channel		620334	636666	653000
		Frequency (MHz)		3305.01	3549.99	3795
10 MHz	pi/2 BPSK	1	0	22.03	22.78	22.36
		1	12	22.06	22.61	22.55
		1	23	22.72	22.41	22.68
		12	0	22.05	22.74	22.22
		12	6	22.01	22.21	22.44
		12	12	22.01	22.35	22.38
		24	0	22.65	22.80	22.23
	QPSK	1	0	21.36	21.31	21.25
		1	12	21.54	21.43	21.05
		1	23	21.35	21.19	21.21
		12	0	21.10	21.13	21.33
		12	6	21.30	21.58	21.50
		12	12	21.49	21.59	21.38
		24	0	21.33	21.58	20.99
	16QAM	1	0	20.52	20.26	20.25
		1	12	20.09	20.72	20.34
		1	23	20.14	20.30	20.34
		12	0	20.17	20.53	20.57
		12	6	20.06	20.29	20.42
		12	12	20.28	20.53	20.26
		24	0	20.65	20.04	20.51
	64QAM	1	0	19.12	19.40	19.16
		1	12	19.59	19.05	19.60
		1	23	19.21	19.48	19.29
		12	0	19.54	19.38	19.22
		12	6	19.38	19.24	19.48
		12	12	19.22	19.37	19.67
		24	0	19.62	19.26	19.15
256QAM	1	0	18.25	18.55	18.77	
	1	12	18.44	18.39	18.57	
	1	23	18.38	18.37	18.77	
	12	0	18.25	18.49	18.61	
	12	6	18.26	18.43	18.73	
	12	12	18.29	18.45	18.59	
	24	0	18.87	18.40	18.41	

3. TISSUE PARAMETERS MEASUREMENTS

Frequency (MHz)	Target Head Tissue		Measured Head Tissue		Deviation %		Measured Date
	Permittivity ϵ	Conductivity σ [S/m]	Permittivity ϵ	Conductivity σ [S/m]	Permittivity ϵ	Conductivity σ [S/m]	
750	41.94	0.89	41.82	0.91	-0.28	2.03	2021-11-24
750	41.94	0.89	41.75	0.90	-0.45	1.15	2021-12-14
835	41.50	0.90	40.98	0.89	-1.25	-1.27	2021-10-27
900	41.50	0.97	40.18	0.96	-3.18	-1.47	2021-10-27
835	41.50	0.90	41.47	0.90	-0.07	-0.45	2021-11-11
900	41.50	0.97	40.68	0.96	-1.98	-0.93	2021-11-11
1750	40.07	1.37	38.78	1.41	-3.22	2.66	2021-11-02
1800	40.00	1.40	38.51	1.45	-3.71	3.75	2021-11-02
1750	40.07	1.37	38.82	1.38	-3.11	0.77	2021-11-30
1800	40.00	1.40	38.55	1.43	-3.63	1.85	2021-11-30
1800	40.00	1.40	39.46	1.34	-1.35	-4.12	2021-11-03
1900	40.00	1.40	39.05	1.41	-2.37	0.38	2021-11-03
1800	40.00	1.40	39.55	1.35	-1.12	-3.73	2021-11-05
1900	40.00	1.40	39.20	1.42	-2.00	1.53	2021-11-05
1800	40.00	1.40	39.58	1.36	-1.04	-2.78	2021-12-27
1900	40.00	1.40	39.20	1.44	-2.01	3.03	2021-12-27
2600	39.00	1.96	38.61	2.05	-1.01	4.84	2021-12-09
2600	39.00	1.96	39.42	1.95	1.07	-0.49	2021-12-15
2600	39.00	1.96	38.56	2.00	-1.13	2.24	2022-01-03
3300	38.14	2.71	39.09	2.78	2.51	2.54	2021-12-20
3300	38.14	2.71	39.35	2.77	3.19	2.26	2021-12-22
3500	37.90	2.91	38.89	2.95	2.61	1.31	2021-12-20
3500	37.90	2.91	39.16	2.94	3.32	0.99	2021-12-22
3700	37.70	3.12	38.62	3.13	2.45	0.39	2021-12-20
3700	37.70	3.12	38.89	3.13	3.17	0.36	2021-12-22
4200	37.16	3.63	37.95	3.59	2.14	-1.08	2021-12-20
4200	37.16	3.63	38.11	3.59	2.55	-1.15	2021-12-22

Note: The dielectric properties have been measured by the contact probe method at 22° C.

- Composition / Information on ingredients

Head and Muscle Tissue Simulation Liquids HSL750V2/MSL750V2

H ₂ O	Water, 35 – 58%
Sucrose	Sugar, white, refined, 40 – 60%
NaCl	Sodium Chloride, 0 – 6%
Hydroxyethyl-cellulose Medium	Viscosity (CAS# 9004-62-0), <0.3%
Preventol-D7	Preservative: aqueous preparation, (CAS# 55965-84-9), containing 5-chloro-2-methyl-3(2H)-isothiazolone and 2-methyl-3(2H)-isothiazolone, 0.1 – 0.7%

Head and Muscle Tissue Simulation Liquids HSL900/MSL900

H ₂ O	Water, 35 – 58%
Sucrose	Sugar, white, refined, 40 – 60%
NaCl	Sodium Chloride, 0 – 6%
Hydroxyethyl-cellulose Medium	Viscosity (CAS# 9004-62-0), <0.3%
Preventol-D7	Preservative: aqueous preparation, (CAS# 55965-84-9), containing 5-chloro-2-methyl-3(2H)-isothiazolone and 2-methyl-3(2H)-isothiazolone, 0.1 – 0.7%

Head and Muscle Tissue Simulation Liquids HBBL1350-1850V3/M HBBL1350-1850V3

H ₂ O	50 – 73 %
Non-ionic detergents	27 – 50 % polyoxyethylenesorbitan monolaurate
NaCl	0 – 2 %
Preservative	0.05 – 0.1% Preventol-D7
Safety relevant ingredients:	
CAS-No. 55965-84-9	< 0.1 % aqueous preparation, containing 5-chloro-2-methyl-3(2H)-isothiazolone and 2-methyl-3(2H)-isothiazolone
CAS-No. 9005-64-5	<50 % polyoxyethylenesorbitan monolaurate

Head and Muscle Tissue Simulation Liquids HSL1800/MSL1800

H ₂ O	Water, 52 – 75%
C8H18O3	Diethylene glycol monobutyl ether (DGBE), 25 – 48% (CAS-No. 112-34-5, EC-No. 203-961-6, EC-index-No. 603-096-00-8)
NaCl	Sodium Chloride, <1.0%

Head and Muscle Tissue Simulation Liquids HBBL1900-3800V3/M HBBL1900-3800V3

H ₂ O	50 – 73 %
Non-ionic detergents	27 – 50 % polyoxyethylenesorbitan monolaurate
NaCl	0 – 2 %
Preservative	0.05 – 0.1% Preventol-D7
Safety relevant ingredients:	
CAS-No. 55965-84-9	< 0.1 % aqueous preparation, containing 5-chloro-2-methyl-3(2H)-isothiazolone and 2-methyl-3(2H)-isothiazolone
CAS-No. 9005-64-5	<50 % polyoxyethylenesorbitan monolaurate

Head and Muscle Tissue Simulation Liquids HBBL3500-5800V5/MBBL3500-5800V5

H ₂ O	76 – 80 %
Mineral Oil	10 – 12 %
Emulsifiers	8 – 10 %
Additives and Salt	1 – 3%

4. SYSTEM CHECK MEASUREMENTS

4.1. Validation results for Head TSL

Date	Frequency (MHz)	SAR over	Fast SAR (W/kg)	SAR (W/kg)	1 W Target SAR (W/kg)	1 W Norm. SAR (W/kg)	Drift (%)
2021-11-24	750	1 gr.	2.24	2.16	8.43	8.64	2.49
		10 gr.	1.49	1.41	5.51	5.64	2.36
2021-12-15	750	1 gr.	2.18	2.13	8.43	8.52	1.07
		10 gr.	1.45	1.39	5.51	5.56	0.91
2021-10-27	900	1 gr.	3.00	2.91	11.10	11.69	5.35
		10 gr.	1.95	1.85	7.07	7.43	5.15
2021-11-11	900	1 gr.	2.75	2.87	11.10	11.48	3.42
		10 gr.	1.75	1.87	7.07	7.48	5.80
2021-11-02	1800	1 gr.	10.50	10.10	39.30	40.12	2.09
		10 gr.	5.55	5.12	20.40	20.34	-0.30
2021-11-03	1800	1 gr.	9.41	9.10	39.30	36.65	-6.74
		10 gr.	4.98	4.74	20.40	19.09	-6.41
2021-11-05	1800	1 gr.	9.80	9.50	39.30	38.18	-2.86
		10 gr.	5.17	4.91	20.40	19.73	-3.28
2021-11-30	1800	1 gr.	10.10	9.69	39.30	38.76	-1.37
		10 gr.	5.35	4.91	20.40	19.64	-3.73
2021-12-27	1800	1 gr.	9.44	9.27	39.30	37.47	-4.67
		10 gr.	4.97	4.78	20.40	19.32	-5.30
2021-12-09	2600	1 gr.	15.00	14.40	57.10	57.27	0.30
		10 gr.	6.71	6.21	25.60	24.70	-3.53
2021-12-16	2600	1 gr.	14.30	13.80	57.10	55.52	-2.77
		10 gr.	6.36	5.98	25.60	24.06	-6.02
2022-01-03	2600	1 gr.	14.40	13.90	57.10	55.60	-2.63
		10 gr.	6.42	6.25	25.60	25.00	-2.34
2021-12-20	3300	1 gr.	6.94	6.74	65.90	67.40	2.28
		10 gr.	2.72	2.63	25.00	26.30	5.20
2021-12-22	3500	1 gr.	6.58	6.59	66.70	65.90	-1.20
		10 gr.	2.54	2.45	25.10	24.50	-2.39
2021-12-20	3700	1 gr.	7.00	7.00	67.70	70.00	3.40
		10 gr.	2.60	2.58	24.50	25.80	5.31
2021-12-20	4200	1 gr.	6.94	6.95	65.50	69.50	6.11
		10 gr.	2.49	2.38	22.20	23.80	7.21

5. MEASUREMENT RESULTS FOR SAR (SPECIFIC ABSORPTION RATE)

5.1. Summary maximum results for 1-g SAR measurements.

Mode	Side / Position	Channel (Frequency)	Reported SAR 1-g (W/kg)	Limit SAR 1-g (W/kg)
GPRS 4 slots 850 MHz	Back face/10 mm	CH 190 (836.6 MHz)	0.903	1.6
GPRS 4 slots 1900 MHz	Back face/10 mm	CH 661 (1880 MHz)	0.544	1.6
WCDMA Band II	Back face/10 mm	CH 9262 (1852.4 MHz)	0.228	1.6
WCDMA Band IV	Back face/10 mm	CH 1512 (1752.6 MHz)	0.218	1.6
WCDMA Band V	Back face/10 mm	CH 4183 (836.6 MHz)	0.270	1.6
LTE Band 4	Back face/10 mm	CH 20300 (1745 MHz)	0.073	1.6
LTE Band 5	Back face/10 mm	CH 20450 (829 MHz)	0.281	1.6
LTE Band 7	Back face/10 mm	CH 21100 (2535.0 MHz)	0.135	1.6
LTE Band 12	Back face/10 mm	CH 23095 (707.5 MHz)	0.211	1.6
LTE Band 13	Back face/10 mm	CH 23230 (782 MHz)	0.250	1.6
LTE Band 25	Back face/10 mm	CH 26140 (1860.0 MHz)	0.108	1.6
LTE Band 26	Back face/10 mm	CH 26865 (831.5 MHz)	0.263	1.6
LTE Band 41	Back face/10 mm	CH 39750 (2506.0 MHz)	0.081	1.6
LTE Band 42	Back face/0 mm	CH 41690 (3410.0 MHz)	0.011	1.6
LTE Band 66	Back face/10 mm	CH 132575 (1770.0 MHz)	0.094	1.6
LTE Band 71	Back face/10 mm	CH 133372 (688.0 MHz)	0.112	1.6
5G NR Band n5	Back face/10 mm	CH 167300 (836.5 MHz)	0.094	1.6
5G NR Band n7	Back face/10 mm	CH 502000 (2510 MHz)	0.080	1.6
5G NR Band n25	Back face/10 mm	CH 374000 (1870.0 MHz)	0.035	1.6
5G NR Band n38	Back face/0 mm	CH 519000 (2595.0 MHz)	0.032	1.6
5G NR Band n41	Back face/0 mm	CH 509202 (2546.0 MHz)	0.026	1.6
5G NR Band n66	Back face/10 mm	CH 349000 (1745.0 MHz)	0.045	1.6
5G NR Band n71	Back face/10 mm	CH 136100 (680.5 MHz)	0.021	1.6
5G NR Band n77	Back face/0 mm	CH 623334 (3350.0 MHz)	0.013	1.6

5.2. Maximum multi-transmission 1-g SAR.

Configuration	Module	Ant	Band	Reported SAR 10-g (W/kg)	Max. SAR 10-g (W/kg)	Σ SARi (W/kg)	Limit SAR 10-g (W/kg)	Verdict
5/6/11/12	NAD2	Int BuA	LTE 42	0.01	0.01	0.913	1.6	Pass
	NAD1	MIMO1/MIMO2	GPRS 850/LTE 42	0.903/0.11	0.903			

5.3. Results for GPRS 850 MHz Band – 4 slots.

- MIMO1 Antenna (Shark fin antenna)

Position	Dist (mm)	Channel (Frequency)	Estimated SAR 1-g (W/kg)	SAR 1-g (W/kg)	Power Drift (%)	Scale factor	Reported SAR 1-g (W/kg)	Plot No.
Back face	10	CH 251 (848.8 MHz)	0.167	0.169	-0.060	4.764	0.805	
Back face	10	CH 128 (824.2 MHz)	0.177	0.186	-0.050	4.842	0.901	
Back face	10	CH 190 (836.6 MHz)	0.180	0.187	0.010	4.831	0.903	1

- Int Bua antenna (TCU internal)

Position	Dist (mm)	Channel (Frequency)	Estimated SAR 1-g (W/kg)	SAR 1-g (W/kg)	Power Drift (%)	Scale factor	Reported SAR 1-g (W/kg)	Plot No.
Back face	10	CH 251 (848.8 MHz)	0.058	0.059	-0.110	4.764	0.281	
Back face	10	CH 128 (824.2 MHz)	0.077	0.079	-0.070	4.842	0.382	2
Back face	10	CH 190 (836.6 MHz)	0.068	0.069	-0.040	4.797	0.331	

5.4. Results for GPRS 1900 MHz Band – 4 slots.

- MIMO1 Antenna (Shark fin antenna)

Position	Dist (mm)	Channel (Frequency)	Estimated SAR 1-g (W/kg)	SAR 1-g (W/kg)	Power Drift (%)	Scale factor	Reported SAR 1-g (W/kg)	Plot No.
Back face	10	CH 512 (1850.2 MHz)	0.042	0.042	-0.090	6.134	0.258	
Back face	10	CH 661 (1880 MHz)	0.042	0.044	-0.090	7.256	0.319	3
Back face	10	CH 810 (1909.8 MHz)	0.023	0.022	-0.060	9.925	0.218	

- Int Bua antenna (TCU internal)

Position	Dist (mm)	Channel (Frequency)	Estimated SAR 1-g (W/kg)	SAR 1-g (W/kg)	Power Drift (%)	Scale factor	Reported SAR 1-g (W/kg)	Plot No.
Back face	10	CH 512 (1850.2 MHz)	0.079	0.085	-0.010	6.134	0.521	
Back face	10	CH 661 (1880 MHz)	0.068	0.075	-0.240	7.256	0.544	4
Back face	10	CH 810 (1909.8 MHz)	0.040	0.045	-0.390	9.925	0.447	

5.5. Results for WCDMA Band II

- MIMO1 Antenna (Shark fin antenna)

Position	Dist (mm)	Channel (Frequency)	Estimated SAR 1-g (W/kg)	SAR 1-g (W/kg)	Power Drift (%)	Scale factor	Reported SAR 1-g (W/kg)	Plot No.
Back face	10	CH 9262 (1852.4 MHz)	0.063	0.065	-0.150	1.562	0.102	5
Back face	10	CH 9400 (1880 MHz)	0.053	0.055	-0.120	1.632	0.090	
Back face	10	CH 9538 (1907.6 MHz)	0.043	0.044	-0.150	1.666	0.073	

- Int Bua antenna (TCU internal)

Position	Dist (mm)	Channel (Frequency)	Estimated SAR 1-g (W/kg)	SAR 1-g (W/kg)	Power Drift (%)	Scale factor	Reported SAR 1-g (W/kg)	Plot No.
Back face	10	CH 9262 (1852.4 MHz)	0.133	0.146	-0.190	1.562	0.228	6
Back face	10	CH 9400 (1880 MHz)	0.108	0.115	-0.060	1.632	0.188	
Back face	10	CH 9538 (1907.6 MHz)	0.098	0.104	-0.110	1.666	0.173	

5.6. Results for WCDMA Band IV

- MIMO1 Antenna (Shark fin antenna)

Position	Dist (mm)	Channel (Frequency)	Estimated SAR 1-g (W/kg)	SAR 1-g (W/kg)	Power Drift (%)	Scale factor	Reported SAR 1-g (W/kg)	Plot No.
Back face	10	CH 1312 (1712.4 MHz)	0.037	0.038	-0.010	1.255	0.048	
Back face	10	CH 1412 (1732.6 MHz)	0.041	0.040	-0.050	1.324	0.053	
Back face	10	CH 1512 (1752.6 MHz)	0.051	0.049	-0.120	1.399	0.069	7

- Int Bua antenna (TCU internal)

Position	Dist (mm)	Channel (Frequency)	Estimated SAR 1-g (W/kg)	SAR 1-g (W/kg)	Power Drift (%)	Scale factor	Reported SAR 1-g (W/kg)	Plot No.
Back face	10	CH 1312 (1712.4 MHz)	0.124	0.137	-0.070	1.255	0.172	
Back face	10	CH 1412 (1732.6 MHz)	0.138	0.146	-0.140	1.324	0.193	
Back face	10	CH 1512 (1752.6 MHz)	0.145	0.156	-0.070	1.399	0.218	8

5.7. Results for WCDMA Band V

- MIMO1 Antenna (Shark fin antenna)

Position	Dist (mm)	Channel (Frequency)	Estimated SAR 1-g (W/kg)	SAR 1-g (W/kg)	Power Drift (%)	Scale factor	Reported SAR 1-g (W/kg)	Plot No.
Back face	10	CH 4132 (826.4 MHz)	0.168	0.174	-0.020	1.536	0.267	
Back face	10	CH 4183 (836.6 MHz)	0.165	0.171	0.000	1.580	0.270	9
Back face	10	CH 4233 (846.6 MHz)	0.155	0.162	0.000	1.613	0.261	

- Int Bua antenna (TCU internal)

Position	Dist (mm)	Channel (Frequency)	Estimated SAR 1-g (W/kg)	SAR 1-g (W/kg)	Power Drift (%)	Scale factor	Reported SAR 1-g (W/kg)	Plot No.
Back face	10	CH 4132 (826.4 MHz)	0.062	0.064	-0.080	1.536	0.098	
Back face	10	CH 4183 (836.6 MHz)	0.061	0.063	-0.110	1.580	0.100	10
Back face	10	CH 4233 (846.6 MHz)	0.060	0.062	-0.090	1.613	0.100	

5.8. Results for LTE Band 2 (1 RB, 20 MHz, QPSK)

SAR for LTE Band 2 has not been measured because it is covered by LTE Band 25 due to overlapping frequency range (LTE Band 2 frequency range: 1850 – 1910 MHz, LTE Band 25 frequency range: 1850 – 1915 MHz) and same maximum tune-up and channel bandwidth.

5.9. Results for LTE Band 4 (1 RB, 20 MHz, QPSK)

- MIMO1 Antenna (Shark fin antenna)

Position	Dist (mm)	Channel (Frequency)	Estimated SAR 1-g (W/kg)	SAR 1-g (W/kg)	Power Drift (%)	Scale factor	Reported SAR 1-g (W/kg)	Plot No.
Back face	10	CH 20050 (1720 MHz)	0.040	0.040	0.010	1.276	0.051	
Back face	10	CH 20175 (1732.5 MHz)	0.041	0.040	-0.040	1.552	0.062	
Back face	10	CH 20300 (1745 MHz)	0.046	0.047	-0.050	1.563	0.073	11

5.10. Results for LTE Band 4 (50% RB, 20 MHz, QPSK)

- MIMO1 Antenna (Shark fin antenna)

Position	Dist (mm)	Channel (Frequency)	Estimated SAR 1-g (W/kg)	SAR 1-g (W/kg)	Power Drift (%)	Scale factor	Reported SAR 1-g (W/kg)	Plot No.
Back face	10	CH 20175 (1732.5 MHz)	0.035	0.034	-0.070	1.413	0.048	

Testing of additional LTE configurations is not required due to the SAR test procedures mentioned in FCC OET KDB 941225 D05 – SAR for LTE Devices v02r05.

5.11. Results for LTE Band 5 (1 RB, 10 MHz, QPSK)

- MIMO1 Antenna (Shark fin antenna)

Position	Dist (mm)	Channel (Frequency)	Estimated SAR 1-g (W/kg)	SAR 1-g (W/kg)	Power Drift (%)	Scale factor	Reported SAR 1-g (W/kg)	Plot No.
Back face	10	CH 20450 (829 MHz)	0.186	0.195	0.020	1.442	0.281	12
Back face	10	CH 20525 (836.5 MHz)	0.156	0.162	0.020	1.483	0.240	
Back face	10	CH 20600 (844.0 MHz)	0.139	0.144	-0.030	1.476	0.213	

5.12. Results for LTE Band 5 (50% RB, 10 MHz, QPSK)

- MIMO1 Antenna (Shark fin antenna)

Position	Dist (mm)	Channel (Frequency)	Estimated SAR 1-g (W/kg)	SAR 1-g (W/kg)	Power Drift (%)	Scale factor	Reported SAR 1-g (W/kg)	Plot No.
Back face	10	CH 20450 (829 MHz)	0.153	0.159	-0.040	1.462	0.232	

Testing of additional LTE configurations is not required due to the SAR test procedures mentioned in FCC OET KDB 941225 D05 – SAR for LTE Devices v02r05.

5.13. Results for LTE Band 7 (1 RB, 20 MHz, QPSK)

- MIMO1 Antenna (Shark fin antenna)

Position	Dist (mm)	Channel (Frequency)	Estimated SAR 1-g (W/kg)	SAR 1-g (W/kg)	Power Drift (%)	Scale factor	Reported SAR 1-g (W/kg)	Plot No.
Back face	10	CH 20850 (2510.0 MHz)	0.130	0.084	0.060	1.076	0.090	
Back face	10	CH 21100 (2535.0 MHz)	0.123	0.117	-0.030	1.156	0.135	13
Back face	10	CH 21350 (2560.0 MHz)	0.105	0.101	-0.630	1.262	0.127	

5.14. Results for LTE Band 7 (50% RB, 20 MHz, QPSK)

- MIMO1 Antenna (Shark fin antenna)

Position	Dist (mm)	Channel (Frequency)	Estimated SAR 1-g (W/kg)	SAR 1-g (W/kg)	Power Drift (%)	Scale factor	Reported SAR 1-g (W/kg)	Plot No.
Back face	10	CH 20850 (2510.0 MHz)	0.111	0.107	-0.060	1.262	0.135	

Testing of additional LTE configurations is not required due to the SAR test procedures mentioned in FCC OET KDB 941225 D05 – SAR for LTE Devices v02r05.

5.15. Results for LTE Band 12 (1 RB, 10 MHz, QPSK)

- MIMO1 Antenna (Shark fin antenna)

Note: According to KDB941225 D05 SAR for LTE Devices, for LTE bands that do not support at least three non-overlapping channels in certain channel bandwidths, the middle channel of the group of overlapping channels should be selected for testing.

Position	Dist (mm)	Channel (Frequency)	Estimated SAR 1-g (W/kg)	SAR 1-g (W/kg)	Power Drift (%)	Scale factor	Reported SAR 1-g (W/kg)	Plot No.
Back face	10	CH 23095 (707.5 MHz)	0.137	0.136	-0.020	1.552	0.211	14

5.16. Results for LTE Band 12 (50% RB, 10 MHz, QPSK)

- MIMO1 Antenna (Shark fin antenna)

Position	Dist (mm)	Channel (Frequency)	Estimated SAR 1-g (W/kg)	SAR 1-g (W/kg)	Power Drift (%)	Scale factor	Reported SAR 1-g (W/kg)	Plot No.
Back face	10	CH 23095 (707.5 MHz)	0.099	0.100	0.060	1.607	0.161	

Testing of additional LTE configurations is not required due to the SAR test procedures mentioned in FCC OET KDB 941225 D05 – SAR for LTE Devices v02r05.

5.17. Results for LTE Band 13 (1 RB, 10 MHz, QPSK)

- MIMO1 Antenna (Shark fin antenna)

Note: According to KDB941225 D05 SAR for LTE Devices, for LTE bands that do not support at least three non-overlapping channels in certain channel bandwidths, the middle channel of the group of overlapping channels should be selected for testing.

Position	Dist (mm)	Channel (Frequency)	Estimated SAR 1-g (W/kg)	SAR 1-g (W/kg)	Power Drift (%)	Scale factor	Reported SAR 1-g (W/kg)	Plot No.
Back face	10	CH 23230 (782 MHz)	0.153	0.155	0.060	1.611	0.250	15

5.18. Results for LTE Band 13 (50% RB, 10 MHz, QPSK)

- MIMO1 Antenna (Shark fin antenna)

Position	Dist (mm)	Channel (Frequency)	Estimated SAR 1-g (W/kg)	SAR 1-g (W/kg)	Power Drift (%)	Scale factor	Reported SAR 1-g (W/kg)	Plot No.
Back face	10	CH 23230 (782 MHz)	0.116	0.117	0.080	1.611	0.188	

Testing of additional LTE configurations is not required due to the SAR test procedures mentioned in FCC OET KDB 941225 D05 – SAR for LTE Devices v02r05.

5.19. Results for LTE Band 17 (1 RB, 10 MHz, QPSK)

SAR for LTE Band 17 has not been measured because it is covered by LTE Band 12 due to overlapping frequency range (LTE Band 17 frequency range: 704 – 716 MHz, LTE Band 12 frequency range: 699 – 716 MHz) and same maximum tune-up and channel bandwidth.

5.20. Results for LTE Band 25 (1 RB, 20 MHz, QPSK)

- MIMO1 Antenna (Shark fin antenna)

Position	Dist (mm)	Channel (Frequency)	Estimated SAR 1-g (W/kg)	SAR 1-g (W/kg)	Power Drift (%)	Scale factor	Reported SAR 1-g (W/kg)	Plot No.
Back face	10	CH 26590 (1905 MHz)	0.047	0.047	-0.190	1.479	0.070	
Back face	10	CH 26140 (1860.0 MHz)	0.068	0.069	-0.120	1.567	0.108	16
Back face	10	CH 26365 (1882.5 MHz)	0.061	0.062	-0.090	1.560	0.097	

5.21. Results for LTE Band 25 (50% RB, 20 MHz, QPSK)

- MIMO1 Antenna (Shark fin antenna)

Position	Dist (mm)	Channel (Frequency)	Estimated SAR 1-g (W/kg)	SAR 1-g (W/kg)	Power Drift (%)	Scale factor	Reported SAR 1-g (W/kg)	Plot No.
Back face	10	CH 26590 (1905 MHz)	0.038	0.038	-0.160	1.542	0.059	

Testing of additional LTE configurations is not required due to the SAR test procedures mentioned in FCC OET KDB 941225 D05 – SAR for LTE Devices v02r05.

5.22. Results for LTE Band 26 (1 RB, 15 MHz, QPSK)

- MIMO1 Antenna (Shark fin antenna)

Note: According to KDB941225 D05 SAR for LTE Devices, for LTE bands that do not support at least three non-overlapping channels in certain channel bandwidths, the middle channel of the group of overlapping channels should be selected for testing.

Position	Dist (mm)	Channel (Frequency)	Estimated SAR 1-g (W/kg)	SAR 1-g (W/kg)	Power Drift (%)	Scale factor	Reported SAR 1-g (W/kg)	Plot No.
Back face	10	CH 26865 (831.5 MHz)	0.167	0.174	-0.010	1.510	0.263	17

5.23. Results for LTE Band 26 (50% RB, 15 MHz, QPSK)

- MIMO1 Antenna (Shark fin antenna)

Position	Dist (mm)	Channel (Frequency)	Estimated SAR 1-g (W/kg)	SAR 1-g (W/kg)	Power Drift (%)	Scale factor	Reported SAR 1-g (W/kg)	Plot No.
Back face	10	CH 26865 (831.5 MHz)	0.141	0.149	-0.010	1.510	0.225	

Testing of additional LTE configurations is not required due to the SAR test procedures mentioned in FCC OET KDB 941225 D05 – SAR for LTE Devices v02r05.

5.24. Results for LTE Band 38 (1 RB, 20 MHz, QPSK)

SAR for LTE Band 38 has not been measured because it is covered by LTE Band 41 due to overlapping frequency range (LTE Band 41 frequency range: 2496 – 2690 MHz, LTE Band 38 frequency range: 2570 – 2620 MHz) and same maximum tune-up and channel bandwidth.

5.25. Results for LTE Band 41 (1 RB, 20 MHz, QPSK)

- MIMO1 Antenna (Shark fin antenna)

Position	Dist (mm)	Channel (Frequency)	Estimated SAR 1-g (W/kg)	SAR 1-g (W/kg)	Power Drift (%)	Scale factor	Reported SAR 1-g (W/kg)	Plot No.
Back face	10	CH 39750 (2506.0 MHz)	0.071	0.069	-0.050	1.180	0.081	18
Back face	10	CH 40185 (2549.5 MHz)	0.032	0.029	0.270	1.462	0.042	
Back face	10	CH 40620 (2593.0 MHz)	0.054	0.053	-0.070	1.462	0.077	
Back face	10	CH 41055 (2636.5 MHz)	0.024	0.025	0.190	1.462	0.037	
Back face	10	CH 41190 (2680.0 MHz)	0.031	0.026	-0.110	1.297	0.034	

5.26. Results for LTE Band 41 (50% RB, 20 MHz, QPSK)

- MIMO1 Antenna (Shark fin antenna)

Position	Dist (mm)	Channel (Frequency)	Estimated SAR 1-g (W/kg)	SAR 1-g (W/kg)	Power Drift (%)	Scale factor	Reported SAR 1-g (W/kg)	Plot No.
Back face	10	CH 39750 (2506.0 MHz)	0.057	0.054	0.000	1.476	0.080	

Testing of additional LTE configurations is not required due to the SAR test procedures mentioned in FCC OET KDB 941225 D05 – SAR for LTE Devices v02r05.

5.27. Results for LTE Band 42 (1 RB, 20 MHz, QPSK)

- MIMO2 Antenna (Shark fin antenna)

Position	Dist (mm)	Channel (Frequency)	Estimated SAR 1-g (W/kg)	SAR 1-g (W/kg)	Power Drift (%)	Scale factor	Reported SAR 1-g (W/kg)	Plot No.
Back face	0	CH 41690 (3410.0 MHz)	0.012	0.011	0.10	1.000	0.011	19
Back face	0	CH 42590 (3500.0 MHz)	0.003	0.002	-0.160	1.081	0.002	
Back face	0	CH 43490 (3590.0 MHz)	0.005	0.003	0.270	1.000	0.003	

- Int Bua antenna (TCU internal)

Position	Dist (mm)	Channel (Frequency)	Estimated SAR 1-g (W/kg)	SAR 1-g (W/kg)	Power Drift (%)	Scale factor	Reported SAR 1-g (W/kg)	Plot No.
Back face	0	CH 41690 (3410.0 MHz)	0.006	0.007	-0.180	1.452	0.010	20
Back face	0	CH 42590 (3500.0 MHz)	0.004	0.0001	0.000	1.710	0.0001	
Back face	0	CH 43490 (3590.0 MHz)	0.006	0.003	0.240	1.742	0.005	

5.28. Results for LTE Band 42 (50% RB, 20 MHz, QPSK)

- MIMO2 Antenna (Shark fin antenna)

Position	Dist (mm)	Channel (Frequency)	Estimated SAR 1-g (W/kg)	SAR 1-g (W/kg)	Power Drift (%)	Scale factor	Reported SAR 1-g (W/kg)	Plot No.
Back face	0	CH 41690 (3410.0 MHz)	0.005	0.004	0.120	1.000	0.004	

- Int Bua antenna (TCU internal)

Position	Dist (mm)	Channel (Frequency)	Estimated SAR 1-g (W/kg)	SAR 1-g (W/kg)	Power Drift (%)	Scale factor	Reported SAR 1-g (W/kg)	Plot No.
Back face	0	CH 41690 (3410.0 MHz)	0.006	0.004	0.260	1.476	0.006	

Testing of additional LTE configurations is not required due to the SAR test procedures mentioned in FCC OET KDB 941225 D05 – SAR for LTE Devices v02r05.

5.29. Results for LTE Band 66 (1 RB, 20 MHz, QPSK)

- MIMO1 Antenna (Shark fin antenna)

Position	Dist (mm)	Channel (Frequency)	Estimated SAR 1-g (W/kg)	SAR 1-g (W/kg)	Power Drift (%)	Scale factor	Reported SAR 1-g (W/kg)	Plot No.
Back face	10	CH 132575 (1770.0 MHz)	0.062	0.062	-0.070	1.521	0.094	21
Back face	10	CH 132072 (1720.0 MHz)	0.040	0.040	-0.110	1.524	0.061	
Back face	10	CH 132322 (1745.0 MHz)	0.052	0.050	-0.100	1.528	0.076	

5.30. Results for LTE Band 66 (50% RB, 20 MHz, QPSK)

- MIMO1 Antenna (Shark fin antenna)

Position	Dist (mm)	Channel (Frequency)	Estimated SAR 1-g (W/kg)	SAR 1-g (W/kg)	Power Drift (%)	Scale factor	Reported SAR 1-g (W/kg)	Plot No.
Back face	10	CH 132575 (1770.0 MHz)	0.050	0.049	-0.010	1.528	0.075	

Testing of additional LTE configurations is not required due to the SAR test procedures mentioned in FCC OET KDB 941225 D05 – SAR for LTE Devices v02r05.

5.31. Results for LTE Band 71 (1 RB, 20 MHz, QPSK)

- MIMO1 Antenna (Shark fin antenna)

Position	Dist (mm)	Channel (Frequency)	Estimated SAR 1-g (W/kg)	SAR 1-g (W/kg)	Power Drift (%)	Scale factor	Reported SAR 1-g (W/kg)	Plot No.
Back face	10	CH 133222 (673.0 MHz)	0.049	0.050	0.080	1.603	0.080	
Back face	10	CH 133297 (680.5 MHz)	0.052	0.052	0.090	1.607	0.084	
Back face	10	CH 133372 (688.0 MHz)	0.071	0.070	0.100	1.607	0.112	22

5.32. Results for LTE Band 71 (50% RB, 20 MHz, QPSK)

- MIMO1 Antenna (Shark fin antenna)

Position	Dist (mm)	Channel (Frequency)	Estimated SAR 1-g (W/kg)	SAR 1-g (W/kg)	Power Drift (%)	Scale factor	Reported SAR 1-g (W/kg)	Plot No.
Back face	10	CH 133297 (680.5 MHz)	0.053	0.053	0.220	1.683	0.089	

Testing of additional LTE configurations is not required due to the SAR test procedures mentioned in FCC OET KDB 941225 D05 – SAR for LTE Devices v02r05.

5.33. Results for LTE Carrier Aggregation inter-band

- MIMO1 Antenna (Shark fin antenna)

CA MODE	Position	Dist (mm)	PCC Config	SCC Config	Estimated SAR 1-g (W/kg)	SAR 1-g (W/kg)	Power Drift (%)	Scale factor	Reported SAR 1-g (W/kg)	Plot No.
5B	Back face	10	1RB High CH 20528 836.8 MHz 5MHz BW	1RB Low CH 20600 844.0 MHz 10MHz BW	0.204	0.211	0.230	2.432	0.513	23
7C	Back face	10	1RB High CH 20850 2510 MHz 20MHz BW	1RB Low CH 21048 2529.8 MHz 20MHz BW	0.098	0.096	-0.120	1.941	0.186	24
41C	Back face	10	1RB High CH 39750 2506.0 MHz 20MHz BW	1RB Low CH 39867 2517.7 MHz 5MHz BW	0.073	0.069	-0.030	2.600	0.179	25
42C	Back face	0	1RB High CH 42565 3497.5 MHz 20MHz BW	1RB Low CH 42682 3509.2 MHz 5MHz BW	0.024	0.021	-0.070	1.549	0.033	26
66B	Back face	10	1RB High CH 132575 1770.0 MHz 10MHz BW	1RB Low CH 132644 1777.2 MHz 5MHz BW	0.075	0.076	-0.050	1.977	0.150	27
66C	Back face	10	1RB High CH 132522 1765.0 MHz 20MHz BW	1RB Low CH 132639 1776.7 MHz 5MHz BW	0.054	0.054	-0.070	2.404	0.130	28

5.34. Results for n2 Band (1 RB, 20 MHz, $\pi/2$ BPSK, SCS 15 kHz)

SAR for n2 Band has not been measured because it is covered by n25 Band due to overlapping frequency range (n2 Band frequency range: 1850 – 1910 MHz, n25 Band frequency range: 1850 – 1915 MHz) and same maximum tune-up and channel bandwidth.

5.35. Results for n5 Band (1 RB, 20 MHz, $\pi/2$ BPSK, SCS 15 kHz)

- MIMO1 Antenna (Shark fin antenna)

Position	Dist (mm)	Channel (Frequency)	Estimated SAR 1-g (W/kg)	SAR 1-g (W/kg)	Power Drift (%)	Scale factor	Reported SAR 1-g (W/kg)	Plot No.
Back face	10	CH 167300 (836.5 MHz)	0.079	0.084	0.010	1.122	0.094	29
Back face	10	CH 166800 (834.0 MHz)	0.080	0.083	-0.070	1.138	0.094	
Back face	10	CH 167800 (839.0 MHz)	0.055	0.059	-0.010	1.138	0.067	

5.36. Results for n5 Band (50% RB, 20 MHz, $\pi/2$ BPSK, SCS 15 kHz)

- MIMO1 Antenna (Shark fin antenna)

Position	Dist (mm)	Channel (Frequency)	Estimated SAR 1-g (W/kg)	SAR 1-g (W/kg)	Power Drift (%)	Scale factor	Reported SAR 1-g (W/kg)	Plot No.
Back face	10	CH 167300 (836.5 MHz)	0.070	0.072	-0.040	1.000	0.072	

Testing of additional LTE configurations is not required due to the SAR test procedures mentioned in FCC OET KDB 941225 D05 – SAR for LTE Devices v02r05.

5.37. Results for n7 Band (1 RB, 20 MHz, $\pi/2$ BPSK, SCS 15 kHz)

- MIMO1 Antenna (Shark fin antenna)

Position	Dist (mm)	Channel (Frequency)	Estimated SAR 1-g (W/kg)	SAR 1-g (W/kg)	Power Drift (%)	Scale factor	Reported SAR 1-g (W/kg)	Plot No.
Back face	10	CH 507000 (2535 MHz)	0.039	0.038	-0.180	1.233	0.047	
Back face	10	CH 502000 (2510 MHz)	0.067	0.064	0.000	1.245	0.080	30
Back face	10	CH 512000 (2560 MHz)	0.045	0.045	-0.070	1.265	0.057	

5.38. Results for n7 Band (50% RB, 20 MHz, $\pi/2$ BPSK, SCS 15 kHz)

- MIMO1 Antenna (Shark fin antenna)

Position	Dist (mm)	Channel (Frequency)	Estimated SAR 1-g (W/kg)	SAR 1-g (W/kg)	Power Drift (%)	Scale factor	Reported SAR 1-g (W/kg)	Plot No.
Back face	10	CH 507000 (2535 MHz)	0.053	0.049	0.130	1.002	0.049	

Testing of additional LTE configurations is not required due to the SAR test procedures mentioned in FCC OET KDB 941225 D05 – SAR for LTE Devices v02r05.

5.39. Results for n25 Band (1 RB, 20 MHz, $\pi/2$ BPSK, SCS 15 kHz)

- MIMO1 Antenna (Shark fin antenna)

Position	Dist (mm)	Channel (Frequency)	Estimated SAR 1-g (W/kg)	SAR 1-g (W/kg)	Power Drift (%)	Scale factor	Reported SAR 1-g (W/kg)	Plot No.
Back face	10	CH 379000 (1895.0 MHz)	0.030	0.028	-0.070	1.230	0.034	
Back face	10	CH 374000 (1870.0 MHz)	0.027	0.028	-0.040	1.259	0.035	31
Back face	10	CH 376500 (1882.5 MHz)	0.026	0.026	-0.190	1.233	0.032	

5.40. Results for n25 Band (50% RB, 20 MHz, $\pi/2$ BPSK, SCS 15 kHz)

- MIMO1 Antenna (Shark fin antenna)

Position	Dist (mm)	Channel (Frequency)	Estimated SAR 1-g (W/kg)	SAR 1-g (W/kg)	Power Drift (%)	Scale factor	Reported SAR 1-g (W/kg)	Plot No.
Back face	10	CH 376500 (1882.5 MHz)	0.025	0.026	-0.100	1.000	0.026	

Testing of additional LTE configurations is not required due to the SAR test procedures mentioned in FCC OET KDB 941225 D05 – SAR for LTE Devices v02r05.

5.41. Results for n38 Band (1 RB, 20 MHz, $\pi/2$ BPSK, SCS 15 kHz)

- MIMO1 Antenna (Shark fin antenna)

Position	Dist (mm)	Channel (Frequency)	Estimated SAR 1-g (W/kg)	SAR 1-g (W/kg)	Power Drift (%)	Scale factor	Reported SAR 1-g (W/kg)	Plot No.
Back face	0	CH 519000 (2595.0 MHz)	0.020	0.020	0.300	1.607	0.032	32
Back face	0	CH 516000 (2480.0 MHz)	0.021	0.019	-0.070	1.618	0.031	
Back face	0	CH 522000 (2610.0 MHz)	0.021	0.016	-0.260	1.626	0.026	

5.42. Results for n38 Band (50% RB, 20 MHz, $\pi/2$ BPSK, SCS 15 kHz)

- MIMO1 Antenna (Shark fin antenna)

Position	Dist (mm)	Channel (Frequency)	Estimated SAR 1-g (W/kg)	SAR 1-g (W/kg)	Power Drift (%)	Scale factor	Reported SAR 1-g (W/kg)	Plot No.
Back face	0	CH 519000 (2595.0 MHz)	0.017	0.011	-0.760	1.400	0.015	

Testing of additional LTE configurations is not required due to the SAR test procedures mentioned in FCC OET KDB 941225 D05 – SAR for LTE Devices v02r05.

5.43. Results for n41 Band (1 RB, 100 MHz, $\pi/2$ BPSK, SCS 30 kHz)

- MIMO1 Antenna (Shark fin antenna)

Position	Dist (mm)	Channel (Frequency)	Estimated SAR 1-g (W/kg)	SAR 1-g (W/kg)	Power Drift (%)	Scale factor	Reported SAR 1-g (W/kg)	Plot No.
Back face	0	CH 528000 (2640.0 MHz)	0.016	0.013	0.210	1.334	0.017	
Back face	0	CH 509202 (2546.0 MHz)	0.018	0.019	0.210	1.377	0.026	33
Back face	0	CH 518598 (2593.0 MHz)	0.020	0.017	-0.540	1.321	0.022	

5.44. Results for n41 Band (50% RB, 100 MHz, $\pi/2$ BPSK, SCS 30 kHz)

- MIMO1 Antenna (Shark fin antenna)

Position	Dist (mm)	Channel (Frequency)	Estimated SAR 1-g (W/kg)	SAR 1-g (W/kg)	Power Drift (%)	Scale factor	Reported SAR 1-g (W/kg)	Plot No.
Back face	0	CH 518598 (2593.0 MHz)	0.015	0.015	-2.340	1.079	0.016	

Testing of additional LTE configurations is not required due to the SAR test procedures mentioned in FCC OET KDB 941225 D05 – SAR for LTE Devices v02r05.

5.45. Results for n66 Band (1 RB, 40 MHz, $\pi/2$ BPSK, SCS 15 kHz)

- MIMO1 Antenna (Shark fin antenna)

Position	Dist (mm)	Channel (Frequency)	Estimated SAR 1-g (W/kg)	SAR 1-g (W/kg)	Power Drift (%)	Scale factor	Reported SAR 1-g (W/kg)	Plot No.
Back face	10	CH 352000 (1760.0 MHz)	0.027	0.027	-0.190	1.230	0.033	
Back face	10	CH 346000 (1730.0 MHz)	0.034	0.033	-0.160	1.236	0.041	
Back face	10	CH 349000 (1745.0 MHz)	0.035	0.036	-0.270	1.259	0.045	34

5.46. Results for n66 Band (50% RB, 40 MHz, $\pi/2$ BPSK, SCS 15 kHz)

- MIMO1 Antenna (Shark fin antenna)

Position	Dist (mm)	Channel (Frequency)	Estimated SAR 1-g (W/kg)	SAR 1-g (W/kg)	Power Drift (%)	Scale factor	Reported SAR 1-g (W/kg)	Plot No.
Back face	10	CH 352000 (1760.0 MHz)	0.027	0.026	-0.250	1.005	0.026	

Testing of additional LTE configurations is not required due to the SAR test procedures mentioned in FCC OET KDB 941225 D05 – SAR for LTE Devices v02r05.

5.47. Results for n71 Band (1 RB, 20 MHz, $\pi/2$ BPSK, SCS 15 kHz)

- MIMO1 Antenna (Shark fin antenna)

Position	Dist (mm)	Channel (Frequency)	Estimated SAR 1-g (W/kg)	SAR 1-g (W/kg)	Power Drift (%)	Scale factor	Reported SAR 1-g (W/kg)	Plot No.
Back face	10	CH 137600 (688.0 MHz)	0.020	0.018	0.510	1.183	0.021	
Back face	10	CH 134600 (673.0 MHz)	0.017	0.016	0.500	1.186	0.019	
Back face	10	CH 136100 (680.5 MHz)	0.020	0.018	0.360	1.191	0.021	35

5.48. Results for n71 Band (50% RB, 20 MHz, $\pi/2$ BPSK, SCS 15 kHz)

- MIMO1 Antenna (Shark fin antenna)

Position	Dist (mm)	Channel (Frequency)	Estimated SAR 1-g (W/kg)	SAR 1-g (W/kg)	Power Drift (%)	Scale factor	Reported SAR 1-g (W/kg)	Plot No.
Back face	10	CH 137600 (688.0 MHz)	0.022	0.020	0.380	1.000	0.020	

Testing of additional LTE configurations is not required due to the SAR test procedures mentioned in FCC OET KDB 941225 D05 – SAR for LTE Devices v02r05.

5.49. Results for n77 Band (1 RB, 20 MHz, $\pi/2$ BPSK, SCS 30 kHz)

- MIMO2 Antenna (Shark fin antenna)

Position	Dist (mm)	Channel (Frequency)	Estimated SAR 1-g (W/kg)	SAR 1-g (W/kg)	Power Drift (%)	Scale factor	Reported SAR 1-g (W/kg)	Plot No.
Back face	0	CH 650000 (3750.0 MHz)	0.003	0.003	0.000	1.633	0.005	
Back face	0	CH 623334 (3350.0 MHz)	0.004	0.004	0.000	1.884	0.008	*
Back face	0	CH 676666 (4149.99.0 MHz)	0.004	0.004	0.000	1.884	0.008	

- Int Bua antenna (TCU internal)

Position	Dist (mm)	Channel (Frequency)	Estimated SAR 1-g (W/kg)	SAR 1-g (W/kg)	Power Drift (%)	Scale factor	Reported SAR 1-g (W/kg)	Plot No.
Back face	0	CH 650000 (3750.0 MHz)	0.005	0.005	0.000	1.633	0.008	
Back face	0	CH 623334 (3350.0 MHz)	0.007	0.007	0.000	1.884	0.013	*
Back face	0	CH 676666 (4149.99.0 MHz)	0.001	0.001	0.000	1.884	0.002	

***Note:** Reported SAR 1-g values are based on the Estimated SAR 1-g values from the area scan, Zoom scan measurements have not been able to be performed by the measurement system due to very low SAR values close to noise level.

5.50. Results for n77 Band (50% RB, 20 MHz, $\pi/2$ BPSK, SCS 30 kHz)

- MIMO2 Antenna (Shark fin antenna)

Position	Dist (mm)	Channel (Frequency)	Estimated SAR 1-g (W/kg)	SAR 1-g (W/kg)	Power Drift (%)	Scale factor	Reported SAR 1-g (W/kg)	Plot No.
Back face	0	CH 650000 (3750.0 MHz)	0.004	0.004	0.000	1.312	0.005	

- Int Bua antenna (TCU internal)

Position	Dist (mm)	Channel (Frequency)	Estimated SAR 1-g (W/kg)	SAR 1-g (W/kg)	Power Drift (%)	Scale factor	Reported SAR 1-g (W/kg)	Plot No.
Back face	0	CH 650000 (3750.0 MHz)	0.005	0.005	0.000	1.312	0.007	

5.51. Results for n78 Band (1 RB, 20 MHz, $\pi/2$ BPSK, SCS 30 kHz)

SAR for n78 Band has not been measured because it is covered by n77 Band due to overlapping frequency range (n77 Band frequency range: 3300 – 4200 MHz, n78 Band frequency range: 3300 – 3800MHz) and same maximum tune-up and channel bandwidth.

5.52. Variability results.

According to KDB 865664 D01 SAR Measurement 100 MHz to 6 GHz, paragraph “2.8.1. SAR measurement variability”, SAR measurement variability must be assessed for each frequency band, which is determined by the SAR probe calibration point and tissue-equivalent medium used for the device measurements. Repeated measurements are required only when the measured 1-g SAR is ≥ 0.80 W/kg, or 10-g SAR is ≥ 2.0 W/kg, using the highest measured SAR configuration for that tissue-equivalent medium.

No variability measurements are required.

5.53. SPOT-CHECK results.

A spot-check measurement for the antenna model DA05DI20 has been performed into the highest SAR measured configuration band found for the antenna model DA04DI20 between bands with same tissue-equivalent liquid.

Band	Antenna Model	Position	Dist (mm)	Channel (Frequency)	Estimated SAR 1-g (W/kg)	SAR 1-g (W/kg)	Power Drift (%)	Plot No.
LTE 5	DA04DI20	Back face	10	CH 20450 (829.0 MHz)	0.186	0.195	0.020	12
LTE 5	DA05DI20	Back face	10	CH 20450 (829.0 MHz)	0.137	0.144	0.070	36

Band	Antenna Model	Position	Dist (mm)	Channel (Frequency)	Estimated SAR 1-g (W/kg)	SAR 1-g (W/kg)	Power Drift (%)	Plot No.
LTE 7	DA04DI20	Back face	10	CH 21100 (2535.0 MHz)	0.123	0.117	-0.030	13
LTE 7	DA05DI20	Back face	10	CH 21100 (2535.0 MHz)	0.063	0.064	-0.120	37

Band	Antenna Model	Position	Dist (mm)	Channel (Frequency)	Estimated SAR 1-g (W/kg)	SAR 1-g (W/kg)	Power Drift (%)	Plot No.
LTE 13	DA04DI20	Back face	10	CH 23230 (782 MHz)	0.153	0.155	0.060	15
LTE 13	DA05DI20	Back face	10	CH 23230 (782 MHz)	0.12	0.122	0.110	38

Band	Antenna Model	Position	Dist (mm)	Channel (Frequency)	Estimated SAR 1-g (W/kg)	SAR 1-g (W/kg)	Power Drift (%)	Plot No.
LTE 25	DA04DI20	Back face	10	CH 26140 (1860.0 MHz)	0.068	0.069	-0.120	16
LTE 25	DA05DI20	Back face	10	CH 26140 (1860.0 MHz)	0.04	0.04	-0.050	39

Band	Antenna Model	Position	Dist (mm)	Channel (Frequency)	Estimated SAR 1-g (W/kg)	SAR 1-g (W/kg)	Power Drift (%)	Plot No.
LTE 42	DA04DI20	Back face	10	CH 41690 (3410.0 MHz)	0.012	0.011	0.250	19
LTE 42	DA05DI20	Back face	10	CH 41690 (3410.0 MHz)	0.005	0.005	-0.020	*

***Note:** SAR 1-g value is based on the Estimated SAR 1-g value from the area scan, Zoom scan measurement was not been able to be performed by the measurement system due to very low SAR values close to noise level.

Band	Antenna Model	Position	Dist (mm)	Channel (Frequency)	Estimated SAR 1-g (W/kg)	SAR 1-g (W/kg)	Power Drift (%)	Plot No.
LTE 66	DA04DI20	Back face	10	CH 132575 (1770.0 MHz)	0.062	0.062	-0.070	21
LTE 66	DA05DI20	Back face	10	CH 132575 (1770.0 MHz)	0.056	0.055	-0.070	40

Band	Antenna Model	Position	Dist (mm)	Channel (Frequency)	Estimated SAR 1-g (W/kg)	SAR 1-g (W/kg)	Power Drift (%)	Plot No.
n77	DA04DI20	Back face	10	CH 623334 (3350.0 MHz)	0.004	0.004	0.000	*
n77	DA05DI20	Back face	10	CH 623334 (3350.0 MHz)	0.004	0.004	0.000	*

***Note:** SAR 1-g values are based on the Estimated SAR 1-g values from the area scan, Zoom scan measurements were not been able to be performed by the measurement system due to very low SAR values close to noise level.

Appendix D: Measurement Reports

Plot N° 1

Measurement Report for Harman wave, BACK, GSM 850, UID 10027 DAC, Channel 190 (836.6MHz)

Device under Test Properties

Model, Manufacturer	Dimensions [mm]	IMEI	DUT Type
Harman wave,	160.0 x 135.0 x 50.0		TCU

Exposure Conditions

Phantom Section, TSL	Position, Test Distance [mm]	Band	Group, UID	Frequency [MHz], Channel Number	Conversion Factor	TSL Conductivity [S/m]	TSL Permittivity
Flat, HSL	BACK, 10.00	GSM 850	GSM, 10027-DAC	836.6, 190	6.12	0.890	41.0

Hardware Setup

Phantom	TSL, Measured Date	Probe, Calibration Date	DAE, Calibration Date
ELI V4.0 (20deg probe tilt) - 1060	HSL900V2 - 2021-10-27 , --	ES3DV3 - SN3052, 2021-09-22	DAE4 Sn1690, 2021-09-08

Scan Setup

	Area Scan	Zoom Scan
Grid Extents [mm]	180.0 x 210.0	30.0 x 30.0 x 30.0
Grid Steps [mm]	15.0 x 15.0	6.0 x 6.0 x 1.5
Sensor Surface [mm]	3.0	3.0
Graded Grid	Yes	Yes
Grading Ratio	1.5	1.5
MAIA	N/A	N/A
Surface Detection	VMS + 6p	VMS + 6p
Scan Method	Measured	Measured

Measurement Results

	Area Scan	Zoom Scan
Date	2021-10-27, 14:45	2021-10-27, 14:51
psSAR1g [W/kg]	0.180	0.187
psSAR10g [W/kg]	0.125	0.134
Power Drift [dB]	0.17	0.01
Power Scaling	Disabled	Disabled
Scaling Factor [dB]		
TSL Correction	No correction	No correction
M2/M1 [%]		90.0
Dist 3dB Peak [mm]		> 15.0

Warning(s) / Error(s)

Details	Area Scan	Zoom Scan
Warning(s)		
Error(s)		

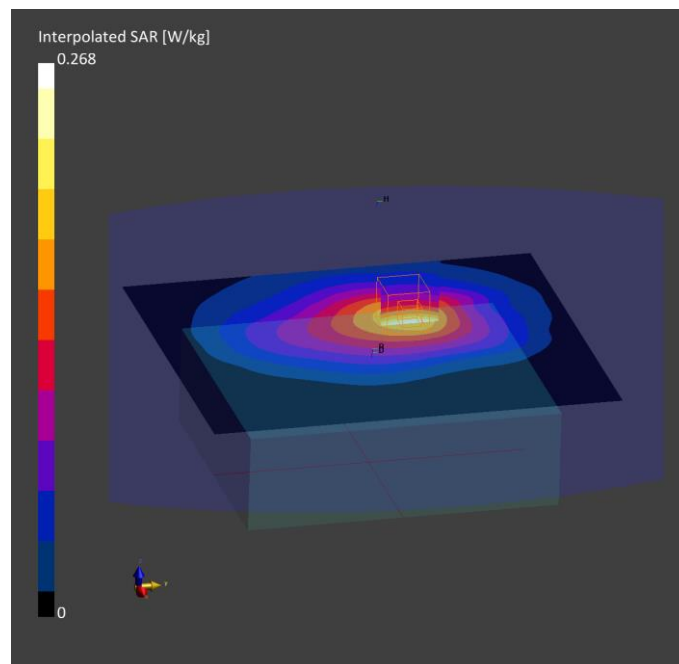

Plot N° 2

Measurement Report for Harman wave, BACK, GSM 850, UID 10027 DAC, Channel 128 (824.2MHz)

Device under Test Properties

Model, Manufacturer	Dimensions [mm]	IMEI	DUT Type
Harman wave,	160.0 x 135.0 x 50.0		TCU

Exposure Conditions

Phantom Section, TSL	Position, Test Distance [mm]	Band	Group, UID	Frequency [MHz], Channel Number	Conversion Factor	TSL Conductivity [S/m]	TSL Permittivity
Flat, HSL	BACK, 10.00	GSM 850	GSM, 10027-DAC	824.2, 128	6.12	0.880	41.1

Hardware Setup

Phantom	TSL, Measured Date	Probe, Calibration Date	DAE, Calibration Date
ELI V4.0 (20deg probe tilt) - 1060	HSL900V2 - 2021-10-27 , --	ES3DV3 - SN3052, 2021-09-22	DAE4 Sn1690, 2021-09-08

Scan Setup

	Area Scan	Zoom Scan
Grid Extents [mm]	180.0 x 210.0	30.0 x 30.0 x 30.0
Grid Steps [mm]	15.0 x 15.0	6.0 x 6.0 x 1.5
Sensor Surface [mm]	3.0	3.0
Graded Grid	Yes	Yes
Grading Ratio	1.5	1.5
MAIA	N/A	N/A
Surface Detection	VMS + 6p	VMS + 6p
Scan Method	Measured	Measured

Measurement Results

	Area Scan	Zoom Scan
Date	2021-10-28, 12:59	2021-10-28, 13:05
psSAR1g [W/kg]	0.077	0.079
psSAR10g [W/kg]	0.053	0.054
Power Drift [dB]	0.05	-0.07
Power Scaling	Disabled	Disabled
Scaling Factor [dB]		
TSL Correction	No correction	No correction
M2/M1 [%]		87.4
Dist 3dB Peak [mm]		> 15.0

Warning(s) / Error(s)

Details	Area Scan	Zoom Scan
Warning(s)		
Error(s)		

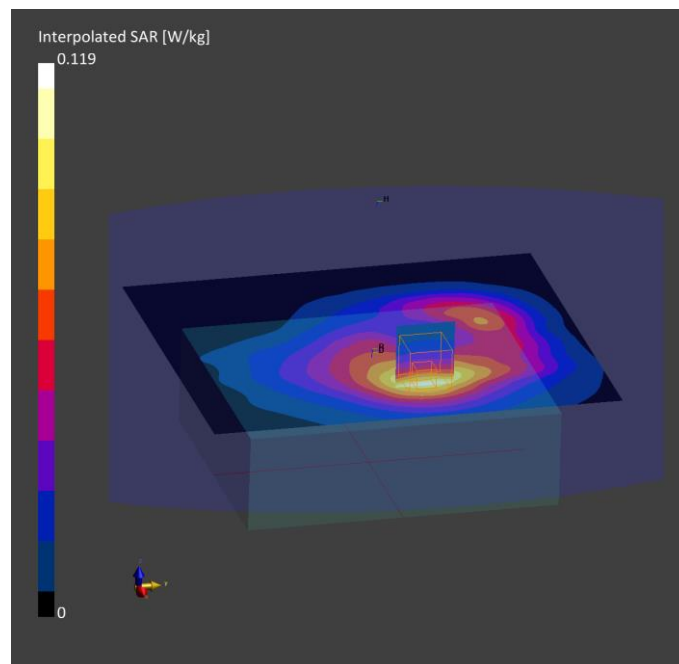

Plot Nº 3

Measurement Report for Harman wave, BACK, PCS 1900, UID 10028 DAC, Channel 661 (1880.0MHz)

Device under Test Properties

Model, Manufacturer	Dimensions [mm]	IMEI	DUT Type
Harman wave,	160.0 x 135.0 x 50.0		TCU

Exposure Conditions

Phantom Section, TSL	Position, Test Distance [mm]	Band	Group, UID	Frequency [MHz], Channel Number	Conversion Factor	TSL Conductivity [S/m]	TSL Permittivity
Flat, HSL	BACK, 10.00	PCS 1900	GSM, 10028-DAC	1880.0, 661	5.28	1.39	39.1

Hardware Setup

Phantom	TSL, Measured Date	Probe, Calibration Date	DAE, Calibration Date
ELI V4.0 (20deg probe tilt) - 1060	HBBL1550-1950V3_Head-03-11-2021, --	ES3DV3 - SN3052, 2021-09-22	DAE4 Sn1690, 2021-09-08

Scan Setup

	Area Scan	Zoom Scan
Grid Extents [mm]	180.0 x 210.0	30.0 x 30.0 x 30.0
Grid Steps [mm]	15.0 x 15.0	6.0 x 6.0 x 1.5
Sensor Surface [mm]	3.0	3.0
Graded Grid	Yes	Yes
Grading Ratio	1.5	1.5
MAIA	Y	Y
Surface Detection	VMS + 6p	VMS + 6p
Scan Method	Measured	Measured

Measurement Results

	Area Scan	Zoom Scan
Date	2021-11-04, 09:14	2021-11-04, 09:20
psSAR1g [W/kg]	0.042	0.044
psSAR10g [W/kg]	0.027	0.026
Power Drift [dB]	-0.00	-0.09
Power Scaling	Disabled	Disabled
Scaling Factor [dB]		
TSL Correction	No correction	No correction
M2/M1 [%]		85.7
Dist 3dB Peak [mm]		> 15.0

Warning(s) / Error(s)

Details	Area Scan	Zoom Scan
Warning(s)		
Error(s)		

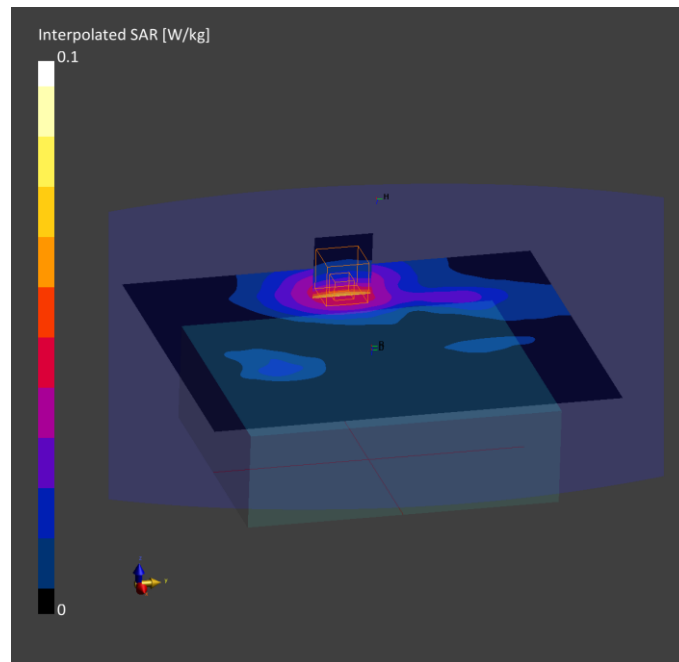

Plot Nº 4

Measurement Report for Harman wave, BACK, PCS 1900, UID 10028 DAC, Channel 661 (1880.0MHz)

Device under Test Properties

Model, Manufacturer	Dimensions [mm]	IMEI	DUT Type
Harman wave,	160.0 x 135.0 x 50.0		TCU

Exposure Conditions

Phantom Section, TSL	Position, Test Distance [mm]	Band	Group, UID	Frequency [MHz], Channel Number	Conversion Factor	TSL Conductivity [S/m]	TSL Permittivity
Flat, HSL	BACK, 10.00	PCS 1900	GSM, 10028-DAC	1880.0, 661	5.28	1.41	39.3

Hardware Setup

Phantom	TSL, Measured Date	Probe, Calibration Date	DAE, Calibration Date
ELI V4.0 (20deg probe tilt) - 1060	HBBL1550-1950V3_Head-05-11-2021, --	ES3DV3 - SN3052, 2021-09-22	DAE4 Sn1690, 2021-09-08

Scan Setup

	Area Scan	Zoom Scan
Grid Extents [mm]	180.0 x 210.0	30.0 x 30.0 x 30.0
Grid Steps [mm]	15.0 x 15.0	6.0 x 6.0 x 1.5
Sensor Surface [mm]	3.0	3.0
Graded Grid	Yes	Yes
Grading Ratio	1.5	1.5
MAIA	Y	Y
Surface Detection	VMS + 6p	VMS + 6p
Scan Method	Measured	Measured

Measurement Results

	Area Scan	Zoom Scan
Date	2021-11-05, 13:08	2021-11-05, 13:15
psSAR1g [W/kg]	0.068	0.075
psSAR10g [W/kg]	0.039	0.041
Power Drift [dB]	0.15	-0.24
Power Scaling	Disabled	Disabled
Scaling Factor [dB]		
TSL Correction	No correction	No correction
M2/M1 [%]		82.3
Dist 3dB Peak [mm]		> 15.0

Warning(s) / Error(s)

Details	Area Scan	Zoom Scan
Warning(s)		
Error(s)		

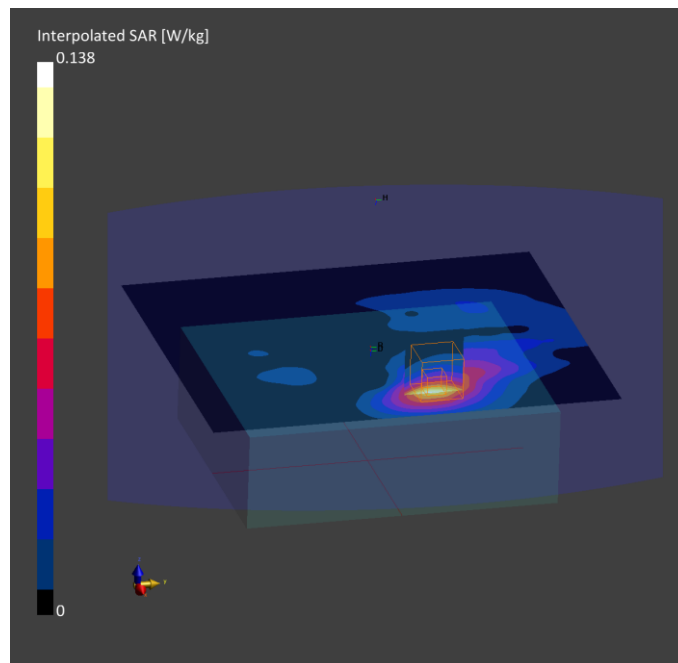

Plot Nº 5

Measurement Report for Harman wave, BACK, Band 2, UTRA/FDD, UID 10011 CAB, Channel 9262 (1852.4MHz)

Device under Test Properties

Model, Manufacturer	Dimensions [mm]	IMEI	DUT Type
Harman wave,	160.0 x 135.0 x 50.0		TCU

Exposure Conditions

Phantom Section, TSL	Position, Test Distance [mm]	Band	Group, UID	Frequency [MHz], Channel Number	Conversion Factor	TSL Conductivity [S/m]	TSL Permittivity
Flat, HSL	BACK, 10.00	Band 2, UTRA/FDD	WCDMA, 10011-CAB	1852.4, 9262	5.28	1.37	39.2

Hardware Setup

Phantom	TSL, Measured Date	Probe, Calibration Date	DAE, Calibration Date
ELI V4.0 (20deg probe tilt) - 1060	HBBL1550-1950V3_Head-03-11-2021, --	ES3DV3 - SN3052, 2021-09-22	DAE4 Sn1690, 2021-09-08

Scan Setup

	Area Scan	Zoom Scan
Grid Extents [mm]	180.0 x 210.0	30.0 x 30.0 x 30.0
Grid Steps [mm]	15.0 x 15.0	6.0 x 6.0 x 1.5
Sensor Surface [mm]	3.0	3.0
Graded Grid	Yes	Yes
Grading Ratio	1.5	1.5
MAIA	Y	Y
Surface Detection	VMS + 6p	VMS + 6p
Scan Method	Measured	Measured

Measurement Results

	Area Scan	Zoom Scan
Date	2021-11-03, 20:45	2021-11-03, 20:51
psSAR1g [W/kg]	0.063	0.065
psSAR10g [W/kg]	0.040	0.041
Power Drift [dB]	0.06	-0.15
Power Scaling	Disabled	Disabled
Scaling Factor [dB]		
TSL Correction	No correction	No correction
M2/M1 [%]		86.0
Dist 3dB Peak [mm]		> 15.0

Warning(s) / Error(s)

Details	Area Scan	Zoom Scan
Warning(s)		
Error(s)		

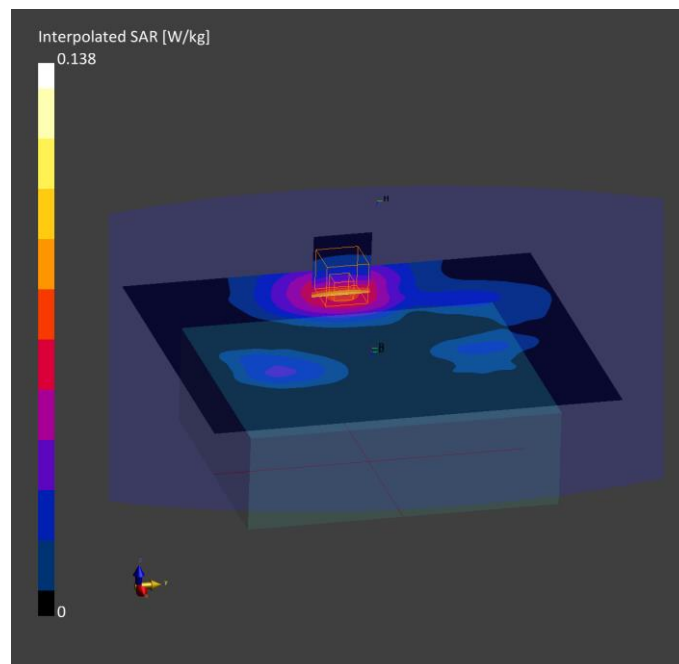

Plot Nº 6

Measurement Report for Harman wave, BACK, Band 2, UTRA/FDD, UID 10011 CAB, Channel 9262 (1852.4MHz)

Device under Test Properties

Model, Manufacturer	Dimensions [mm]	IMEI	DUT Type
Harman wave,	160.0 x 135.0 x 50.0		TCU

Exposure Conditions

Phantom Section, TSL	Position, Test Distance [mm]	Band	Group, UID	Frequency [MHz], Channel Number	Conversion Factor	TSL Conductivity [S/m]	TSL Permittivity
Flat, HSL	BACK, 10.00	Band 2, UTRA/FDD	WCDMA, 10011-CAB	1852.4, 9262	5.28	1.39	39.4

Hardware Setup

Phantom	TSL, Measured Date	Probe, Calibration Date	DAE, Calibration Date
ELI V4.0 (20deg probe tilt) - 1060	HBBL1550-1950V3_Head-05-11-2021, --	ES3DV3 - SN3052, 2021-09-22	DAE4 Sn1690, 2021-09-08

Scan Setup

	Area Scan	Zoom Scan
Grid Extents [mm]	180.0 x 210.0	30.0 x 30.0 x 30.0
Grid Steps [mm]	15.0 x 15.0	6.0 x 6.0 x 1.5
Sensor Surface [mm]	3.0	3.0
Graded Grid	Yes	Yes
Grading Ratio	1.5	1.5
MAIA	N/A	N/A
Surface Detection	VMS + 6p	VMS + 6p
Scan Method	Measured	Measured

Measurement Results

	Area Scan	Zoom Scan
Date	2021-11-05, 15:41	2021-11-05, 15:47
psSAR1g [W/kg]	0.133	0.146
psSAR10g [W/kg]	0.077	0.079
Power Drift [dB]	0.21	-0.19
Power Scaling	Disabled	Disabled
Scaling Factor [dB]		
TSL Correction	No correction	No correction
M2/M1 [%]		83.1
Dist 3dB Peak [mm]		14.4

Warning(s) / Error(s)

Details	Area Scan	Zoom Scan
Warning(s)		
Error(s)		

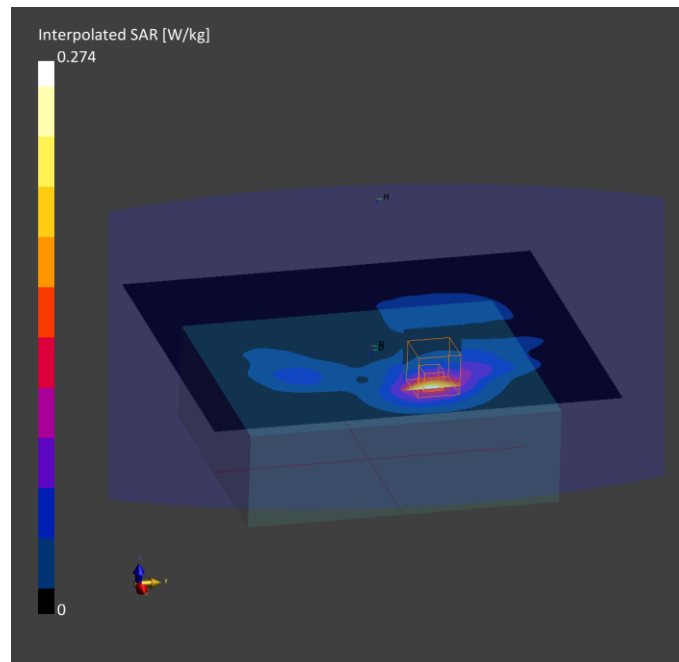

Plot Nº 7

Measurement Report for Harman wave, BACK, Band 4, UTRA/FDD, UID 10011 CAB, Channel 1512 (1752.4MHz)

Device under Test Properties

Model, Manufacturer	Dimensions [mm]	IMEI	DUT Type
Harman wave,	160.0 x 135.0 x 50.0		TCU

Exposure Conditions

Phantom Section, TSL	Position, Test Distance [mm]	Band	Group, UID	Frequency [MHz], Channel Number	Conversion Factor	TSL Conductivity [S/m]	TSL Permittivity
Flat, HSL	BACK, 10.00	Band 4, UTRA/FDD	WCDMA, 10011-CAB	1752.4, 1512	5.28	1.41	38.8

Hardware Setup

Phantom	TSL, Measured Date	Probe, Calibration Date	DAE, Calibration Date
ELI V4.0 (20deg probe tilt) - 1060	HBBL1350-1850V3-1700MHz-2021-11-02, --	ES3DV3 - SN3052, 2021-09-22	DAE4 Sn1690, 2021-09-08

Scan Setup

	Area Scan	Zoom Scan
Grid Extents [mm]	180.0 x 210.0	30.0 x 30.0 x 30.0
Grid Steps [mm]	15.0 x 15.0	6.0 x 6.0 x 1.5
Sensor Surface [mm]	3.0	3.0
Graded Grid	Yes	Yes
Grading Ratio	1.5	1.5
MAIA	Y	Y
Surface Detection	VMS + 6p	VMS + 6p
Scan Method	Measured	Measured

Measurement Results

	Area Scan	Zoom Scan
Date	2021-11-02, 11:32	2021-11-02, 11:38
psSAR1g [W/kg]	0.051	0.049
psSAR10g [W/kg]	0.030	0.028
Power Drift [dB]	-0.01	-0.12
Power Scaling	Disabled	Disabled
Scaling Factor [dB]		
TSL Correction	No correction	No correction
M2/M1 [%]		86.4
Dist 3dB Peak [mm]		> 15.0

Warning(s) / Error(s)

Details	Area Scan	Zoom Scan
Warning(s)		
Error(s)		

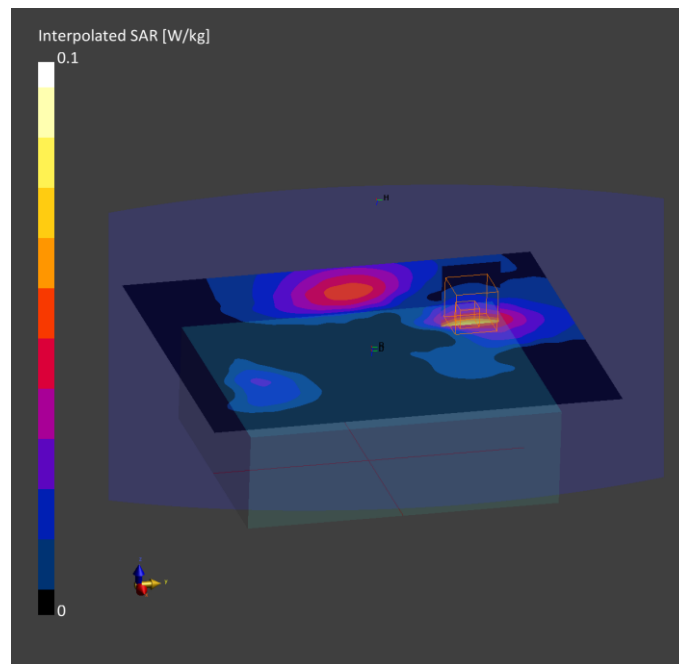

Plot Nº 8

Measurement Report for Harman wave, BACK, Band 4, UTRA/FDD, UID 10011 CAB, Channel 1512 (1752.4MHz)

Device under Test Properties

Model, Manufacturer	Dimensions [mm]	IMEI	DUT Type
Harman wave,	160.0 x 135.0 x 50.0		TCU

Exposure Conditions

Phantom Section, TSL	Position, Test Distance [mm]	Band	Group, UID	Frequency [MHz], Channel Number	Conversion Factor	TSL Conductivity [S/m]	TSL Permittivity
Flat, HSL	BACK, 10.00	Band 4, UTRA/FDD	WCDMA, 10011-CAB	1752.4, 1512	5.28	1.41	38.8

Hardware Setup

Phantom	TSL, Measured Date	Probe, Calibration Date	DAE, Calibration Date
ELI V4.0 (20deg probe tilt) - 1060	HBBL1350-1850V3-1700MHz-2021-11-02, --	ES3DV3 - SN3052, 2021-09-22	DAE4 Sn1690, 2021-09-08

Scan Setup

	Area Scan	Zoom Scan
Grid Extents [mm]	180.0 x 210.0	30.0 x 30.0 x 30.0
Grid Steps [mm]	15.0 x 15.0	6.0 x 6.0 x 1.5
Sensor Surface [mm]	3.0	3.0
Graded Grid	Yes	Yes
Grading Ratio	1.5	1.5
MAIA	N/A	N/A
Surface Detection	VMS + 6p	VMS + 6p
Scan Method	Measured	Measured

Measurement Results

	Area Scan	Zoom Scan
Date	2021-11-02, 14:41	2021-11-02, 14:47
psSAR1g [W/kg]	0.145	0.156
psSAR10g [W/kg]	0.089	0.087
Power Drift [dB]	-0.01	-0.07
Power Scaling	Disabled	Disabled
Scaling Factor [dB]		
TSL Correction	No correction	No correction
M2/M1 [%]		82.5
Dist 3dB Peak [mm]		18.3

Warning(s) / Error(s)

Details	Area Scan	Zoom Scan
Warning(s)		
Error(s)		

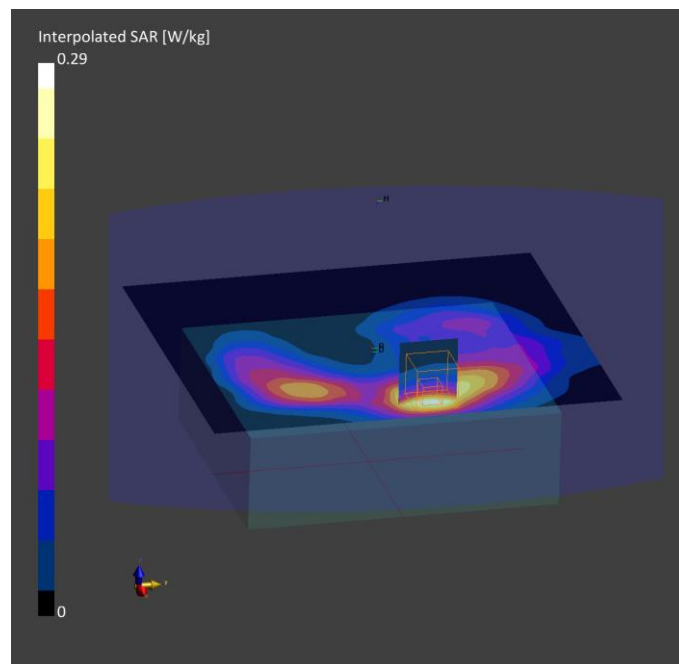

Plot Nº 9

Measurement Report for Harman wave, BACK, Band 5, UTRA/FDD, UID 10011 CAB, Channel 4183 (836.6MHz)

Device under Test Properties

Model, Manufacturer	Dimensions [mm]	IMEI	DUT Type
Harman wave,	160.0 x 135.0 x 50.0		TCU

Exposure Conditions

Phantom Section, TSL	Position, Test Distance [mm]	Band	Group, UID	Frequency [MHz], Channel Number	Conversion Factor	TSL Conductivity [S/m]	TSL Permittivity
Flat, HSL	BACK, 10.00	Band 5, UTRA/FDD	WCDMA, 10011-CAB	836.6, 4183	6.12	0.890	41.0

Hardware Setup

Phantom	TSL, Measured Date	Probe, Calibration Date	DAE, Calibration Date
ELI V4.0 (20deg probe tilt) - 1060	HSL900V2 - 2021-10-27 , --	ES3DV3 - SN3052, 2021-09-22	DAE4 Sn1690, 2021-09-08

Scan Setup

	Area Scan	Zoom Scan
Grid Extents [mm]	180.0 x 210.0	30.0 x 30.0 x 30.0
Grid Steps [mm]	15.0 x 15.0	6.0 x 6.0 x 1.5
Sensor Surface [mm]	3.0	3.0
Graded Grid	Yes	Yes
Grading Ratio	1.5	1.5
MAIA	N/A	N/A
Surface Detection	VMS + 6p	VMS + 6p
Scan Method	Measured	Measured

Measurement Results

	Area Scan	Zoom Scan
Date	2021-10-27, 15:48	2021-10-27, 15:54
psSAR1g [W/kg]	0.165	0.171
psSAR10g [W/kg]	0.115	0.122
Power Drift [dB]	0.01	-0.00
Power Scaling	Disabled	Disabled
Scaling Factor [dB]		
TSL Correction	No correction	No correction
M2/M1 [%]		90.8
Dist 3dB Peak [mm]		> 15.0

Warning(s) / Error(s)

Details	Area Scan	Zoom Scan
Warning(s)		
Error(s)		

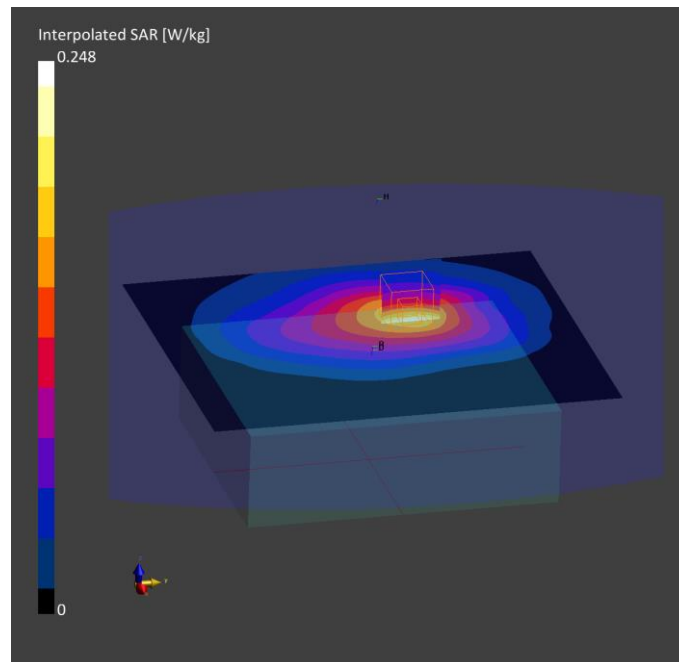

Plot N° 10

Measurement Report for Harman wave, BACK, Band 5, UTRA/FDD, UID 10011 CAB, Channel 4183 (836.6MHz)

Device under Test Properties

Model, Manufacturer	Dimensions [mm]	IMEI	DUT Type
Harman wave,	160.0 x 135.0 x 50.0		TCU

Exposure Conditions

Phantom Section, TSL	Position, Test Distance [mm]	Band	Group, UID	Frequency [MHz], Channel Number	Conversion Factor	TSL Conductivity [S/m]	TSL Permittivity
Flat, HSL	BACK, 10.00	Band 5, UTRA/FDD	WCDMA, 10011-CAB	836.6, 4183	6.12	0.890	41.0

Hardware Setup

Phantom	TSL, Measured Date	Probe, Calibration Date	DAE, Calibration Date
ELI V4.0 (20deg probe tilt) - 1060	HSL900V2 - 2021-10-27 , --	ES3DV3 - SN3052, 2021-09-22	DAE4 Sn1690, 2021-09-08

Scan Setup

	Area Scan	Zoom Scan
Grid Extents [mm]	180.0 x 210.0	30.0 x 30.0 x 30.0
Grid Steps [mm]	15.0 x 15.0	6.0 x 6.0 x 1.5
Sensor Surface [mm]	3.0	3.0
Graded Grid	Yes	Yes
Grading Ratio	1.5	1.5
MAIA	Y	Y
Surface Detection	VMS + 6p	VMS + 6p
Scan Method	Measured	Measured

Measurement Results

	Area Scan	Zoom Scan
Date	2021-10-28, 14:17	2021-10-28, 14:23
psSAR1g [W/kg]	0.061	0.063
psSAR10g [W/kg]	0.041	0.043
Power Drift [dB]	0.01	-0.11
Power Scaling	Disabled	Disabled
Scaling Factor [dB]		
TSL Correction	No correction	No correction
M2/M1 [%]		87.3
Dist 3dB Peak [mm]		> 15.0

Warning(s) / Error(s)

Details	Area Scan	Zoom Scan
Warning(s)		
Error(s)		

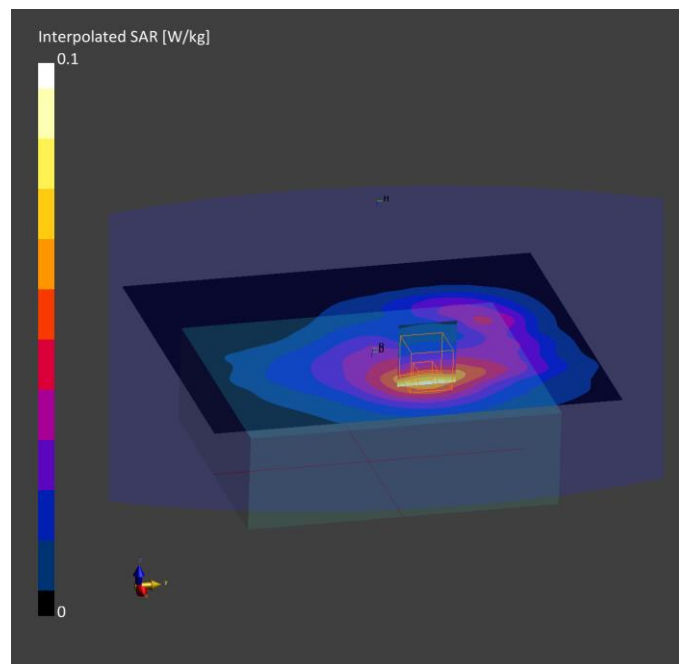

Plot Nº 11

Measurement Report for Harman wave, BACK, Band 4, E-UTRA/FDD, UID 10169 CAE, Channel 20300 (1745.0MHz)

Device under Test Properties

Model, Manufacturer	Dimensions [mm]	IMEI	DUT Type
Harman wave,	160.0 x 135.0 x 50.0		TCU

Exposure Conditions

Phantom Section, TSL	Position, Test Distance [mm]	Band	Group, UID	Frequency [MHz], Channel Number	Conversion Factor	TSL Conductivity [S/m]	TSL Permittivity
Flat, HSL	BACK, 10.00	Band 4, E-UTRA/FDD	LTE-FDD, 10169-CAE	1745.0, 20300	5.28	1.41	38.8

Hardware Setup

Phantom	TSL, Measured Date	Probe, Calibration Date	DAE, Calibration Date
ELI V4.0 (20deg probe tilt) - 1060	HBBL1350-1850V3-1700MHz-2021-11-02, --	ES3DV3 - SN3052, 2021-09-22	DAE4 Sn1690, 2021-09-08

Scan Setup

	Area Scan	Zoom Scan
Grid Extents [mm]	180.0 x 210.0	30.0 x 30.0 x 30.0
Grid Steps [mm]	15.0 x 15.0	6.0 x 6.0 x 1.5
Sensor Surface [mm]	3.0	3.0
Graded Grid	Yes	Yes
Grading Ratio	1.5	1.5
MAIA	Y	Y
Surface Detection	VMS + 6p	VMS + 6p
Scan Method	Measured	Measured

Measurement Results

	Area Scan	Zoom Scan
Date	2021-11-02, 12:54	2021-11-02, 13:00
psSAR1g [W/kg]	0.046	0.047
psSAR10g [W/kg]	0.029	0.029
Power Drift [dB]	0.07	-0.05
Power Scaling	Disabled	Disabled
Scaling Factor [dB]		
TSL Correction	No correction	No correction
M2/M1 [%]		84.6
Dist 3dB Peak [mm]		> 15.0

Warning(s) / Error(s)

Details	Area Scan	Zoom Scan
Warning(s)		
Error(s)		

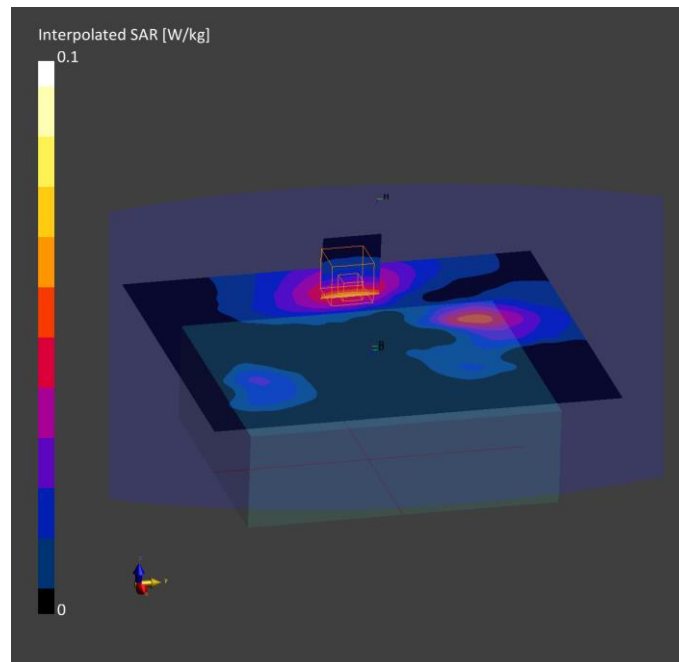

Plot N° 12

Measurement Report for Harman wave, BACK, Band 5, E-UTRA/FDD, UID 10175 CAG, Channel 20450 (829.0MHz)

Device under Test Properties

Model, Manufacturer	Dimensions [mm]	IMEI	DUT Type
Harman wave,	160.0 x 135.0 x 50.0		TCU

Exposure Conditions

Phantom Section, TSL	Position, Test Distance [mm]	Band	Group, UID	Frequency [MHz], Channel Number	Conversion Factor	TSL Conductivity [S/m]	TSL Permittivity
Flat, HSL	BACK, 10.00	Band 5, E-UTRA/FDD	LTE-FDD, 10175-CAG	829.0, 20450	6.12	0.880	41.1

Hardware Setup

Phantom	TSL, Measured Date	Probe, Calibration Date	DAE, Calibration Date
ELI V4.0 (20deg probe tilt) - 1060	HSL900V2 - 2021-10-27 , --	ES3DV3 - SN3052, 2021-09-22	DAE4 Sn1690, 2021-09-08

Scan Setup

	Area Scan	Zoom Scan
Grid Extents [mm]	180.0 x 210.0	30.0 x 30.0 x 30.0
Grid Steps [mm]	15.0 x 15.0	6.0 x 6.0 x 1.5
Sensor Surface [mm]	3.0	3.0
Graded Grid	Yes	Yes
Grading Ratio	1.5	1.5
MAIA	N/A	N/A
Surface Detection	VMS + 6p	VMS + 6p
Scan Method	Measured	Measured

Measurement Results

	Area Scan	Zoom Scan
Date	2021-10-27, 16:52	2021-10-27, 16:58
psSAR1g [W/kg]	0.186	0.195
psSAR10g [W/kg]	0.130	0.140
Power Drift [dB]	0.04	0.02
Power Scaling	Disabled	Disabled
Scaling Factor [dB]		
TSL Correction	No correction	No correction
M2/M1 [%]		90.8
Dist 3dB Peak [mm]		> 15.0

Warning(s) / Error(s)

Details	Area Scan	Zoom Scan
Warning(s)		
Error(s)		

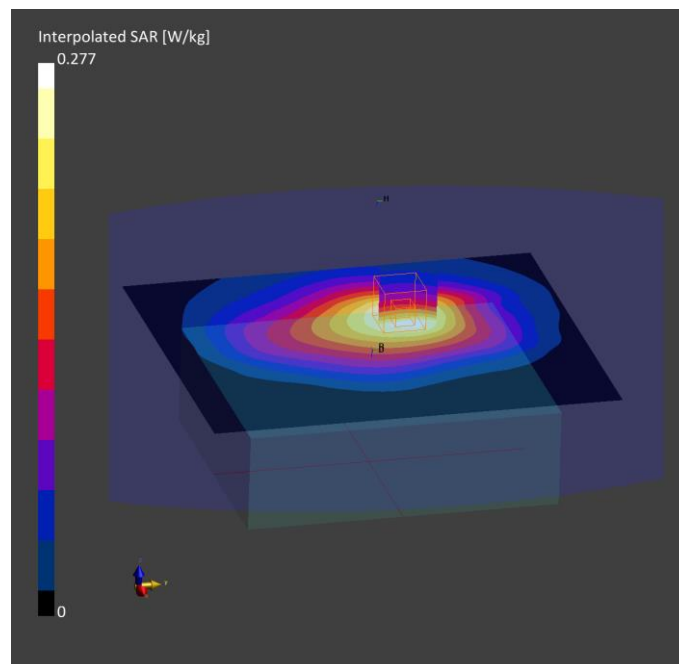

Plot N° 13

Measurement Report for Harman wave, BACK, Band 7, E-UTRA/FDD, UID 10169 CAE, Channel 21100 (2535.0MHz)

Device under Test Properties

Model, Manufacturer	Dimensions [mm]	IMEI	DUT Type
Harman wave,	160.0 x 135.0 x 50.0	350117360052896	TCU

Exposure Conditions

Phantom Section, TSL	Position, Test Distance [mm]	Band	Group, UID	Frequency [MHz], Channel Number	Conversion Factor	TSL Conductivity [S/m]	TSL Permittivity
Flat, HSL	BACK, 10.00	Band 7, E-UTRA/FDD	LTE-FDD, 10169-CAE	2535.0, 21100	7.27	1.96	39.0

Hardware Setup

Phantom	TSL, Measured Date	Probe, Calibration Date	DAE, Calibration Date
ELI V4.0 (20deg probe tilt) - 1060	HBBL1900-3800V3-2600MHz-2021-12-09, --	EX3DV4 - SN7461, 2020-08-28	DAE4 Sn669, 2021-09-13

Scan Setup

	Area Scan	Zoom Scan
Grid Extents [mm]	180.0 x 200.0	30.0 x 30.0 x 30.0
Grid Steps [mm]	10.0 x 10.0	5.0 x 5.0 x 1.5
Sensor Surface [mm]	3.0	1.4
Graded Grid	Yes	Yes
Grading Ratio	1.5	1.5
MAIA	Y	Y
Surface Detection	VMS + 6p	VMS + 6p
Scan Method	Measured	Measured

Measurement Results

	Area Scan	Zoom Scan
Date	2021-12-11, 11:35	2021-12-11, 11:43
psSAR1g [W/kg]	0.123	0.117
psSAR10g [W/kg]	0.063	0.059
Power Drift [dB]	-0.03	-0.03
Power Scaling	Disabled	Disabled
Scaling Factor [dB]		
TSL Correction	No correction	No correction
M2/M1 [%]		78.8
Dist 3dB Peak [mm]		14.1

Warning(s) / Error(s)

Details	Area Scan	Zoom Scan
Warning(s)		
Error(s)		

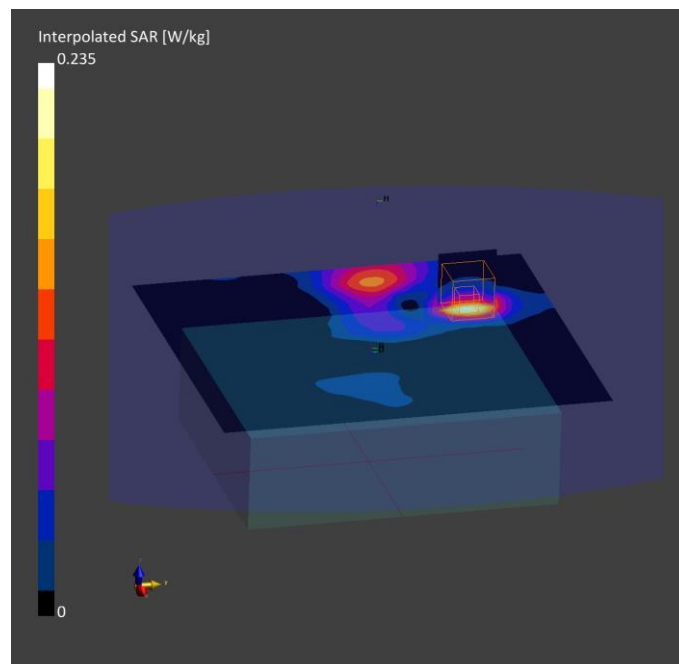

Plot N° 14

Measurement Report for Harman wave, BACK, Band 12, E-UTRA/FDD, UID 10175 CAG, Channel 23095 (707.5MHz)

Device under Test Properties

Model, Manufacturer	Dimensions [mm]	IMEI	DUT Type
Harman wave,	160.0 x 135.0 x 50.0	350117360051443	TCU

Exposure Conditions

Phantom Section, TSL	Position, Test Distance [mm]	Band	Group, UID	Frequency [MHz], Channel Number	Conversion Factor	TSL Conductivity [S/m]	TSL Permittivity
Flat, HSL	BACK, 10.00	Band 12, E-UTRA/FDD	LTE-FDD, 10175-CAG	707.5, 23095	9.84	0.865	42.5

Hardware Setup

Phantom	TSL, Measured Date	Probe, Calibration Date	DAE, Calibration Date
ELI V4.0 (20deg probe tilt) - 1060	HSL750V2-2021-11-24 , --	EX3DV4 - SN7461, 2020-08-28	DAE4 Sn669, 2021-09-13

Scan Setup

	Area Scan	Zoom Scan
Grid Extents [mm]	180.0 x 210.0	30.0 x 30.0 x 30.0
Grid Steps [mm]	15.0 x 15.0	6.0 x 6.0 x 1.5
Sensor Surface [mm]	3.0	1.4
Graded Grid	Yes	Yes
Grading Ratio	1.5	1.5
MAIA	N/A	N/A
Surface Detection	VMS + 6p	All points
Scan Method	Measured	Measured

Measurement Results

	Area Scan	Zoom Scan
Date	2021-11-25, 10:40	2021-11-25, 10:53
psSAR1g [W/kg]	0.137	0.136
psSAR10g [W/kg]	0.096	0.101
Power Drift [dB]	0.14	-0.02
Power Scaling	Disabled	Disabled
Scaling Factor [dB]		
TSL Correction	No correction	No correction
M2/M1 [%]		88.5
Dist 3dB Peak [mm]		> 15.0

Warning(s) / Error(s)

Details	Area Scan	Zoom Scan
Warning(s)		
Error(s)		

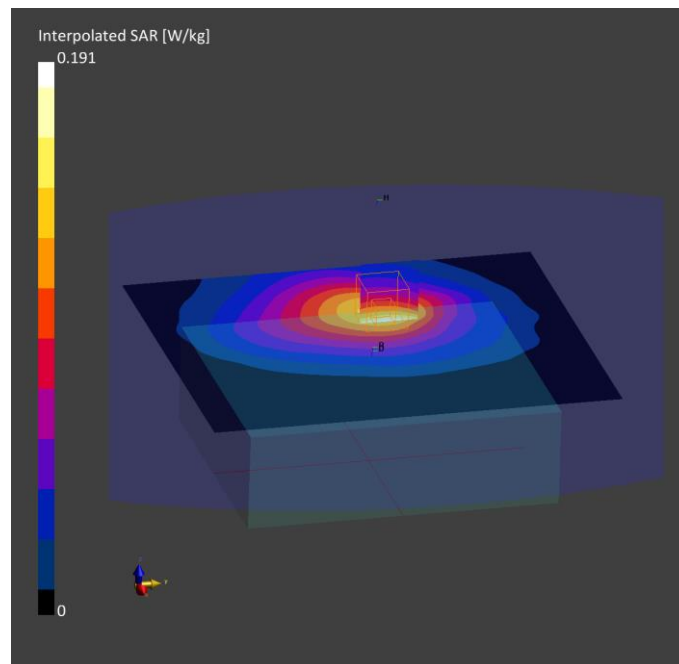

Plot N° 15

Measurement Report for Harman wave, BACK, Band 13, E-UTRA/FDD, UID 10175 CAG, Channel 23230 (782.0MHz)

Device under Test Properties

Model, Manufacturer	Dimensions [mm]	IMEI	DUT Type
Harman wave,	160.0 x 135.0 x 50.0	350117360051443	TCU

Exposure Conditions

Phantom Section, TSL	Position, Test Distance [mm]	Band	Group, UID	Frequency [MHz], Channel Number	Conversion Factor	TSL Conductivity [S/m]	TSL Permittivity
Flat, HSL	BACK, 10.00	Band 13, E-UTRA/FDD	LTE-FDD, 10175-CAG	782.0, 23230	9.84	0.934	41.4

Hardware Setup

Phantom	TSL, Measured Date	Probe, Calibration Date	DAE, Calibration Date
ELI V4.0 (20deg probe tilt) - 1060	HSL750V2-2021-11-24 , --	EX3DV4 - SN7461, 2020-08-28	DAE4 Sn669, 2021-09-13

Scan Setup

	Area Scan	Zoom Scan
Grid Extents [mm]	180.0 x 210.0	30.0 x 30.0 x 30.0
Grid Steps [mm]	15.0 x 15.0	6.0 x 6.0 x 1.5
Sensor Surface [mm]	3.0	1.4
Graded Grid	Yes	Yes
Grading Ratio	1.5	1.5
MAIA	N/A	N/A
Surface Detection	VMS + 6p	All points
Scan Method	Measured	Measured

Measurement Results

	Area Scan	Zoom Scan
Date	2021-11-25, 13:09	2021-11-25, 13:22
psSAR1g [W/kg]	0.153	0.155
psSAR10g [W/kg]	0.106	0.112
Power Drift [dB]	0.14	0.06
Power Scaling	Disabled	Disabled
Scaling Factor [dB]		
TSL Correction	No correction	No correction
M2/M1 [%]		87.7
Dist 3dB Peak [mm]		> 15.0

Warning(s) / Error(s)

Details	Area Scan	Zoom Scan
Warning(s)		
Error(s)		

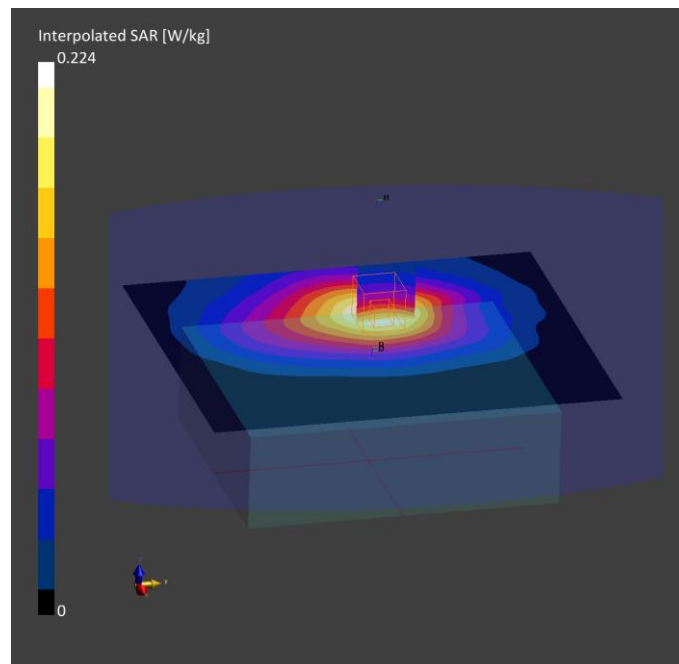

Plot N° 16

Measurement Report for Harman wave, BACK, Band 25, E-UTRA/FDD, UID 10169 CAE, Channel 26140 (1860.0MHz)

Device under Test Properties

Model, Manufacturer	Dimensions [mm]	IMEI	DUT Type
Harman wave,	160.0 x 135.0 x 50.0		TCU

Exposure Conditions

Phantom Section, TSL	Position, Test Distance [mm]	Band	Group, UID	Frequency [MHz], Channel Number	Conversion Factor	TSL Conductivity [S/m]	TSL Permittivity
Flat, HSL	BACK, 10.00	Band 25, E-UTRA/FDD	LTE-FDD, 10169-CAE	1860.0, 26140	5.28	1.38	39.2

Hardware Setup

Phantom	TSL, Measured Date	Probe, Calibration Date	DAE, Calibration Date
ELI V4.0 (20deg probe tilt) - 1060	HBBL1550-1950V3_Head-03-11-2021, --	ES3DV3 - SN3052, 2021-09-22	DAE4 Sn1690, 2021-09-08

Scan Setup

	Area Scan	Zoom Scan
Grid Extents [mm]	180.0 x 210.0	30.0 x 30.0 x 30.0
Grid Steps [mm]	15.0 x 15.0	6.0 x 6.0 x 1.5
Sensor Surface [mm]	3.0	3.0
Graded Grid	Yes	Yes
Grading Ratio	1.5	1.5
MAIA	Y	Y
Surface Detection	VMS + 6p	VMS + 6p
Scan Method	Measured	Measured

Measurement Results

	Area Scan	Zoom Scan
Date	2021-11-03, 21:35	2021-11-03, 21:42
psSAR1g [W/kg]	0.068	0.069
psSAR10g [W/kg]	0.043	0.043
Power Drift [dB]	0.01	-0.12
Power Scaling	Disabled	Disabled
Scaling Factor [dB]		
TSL Correction	No correction	No correction
M2/M1 [%]		83.5
Dist 3dB Peak [mm]		> 15.0

Warning(s) / Error(s)

Details	Area Scan	Zoom Scan
Warning(s)		
Error(s)		

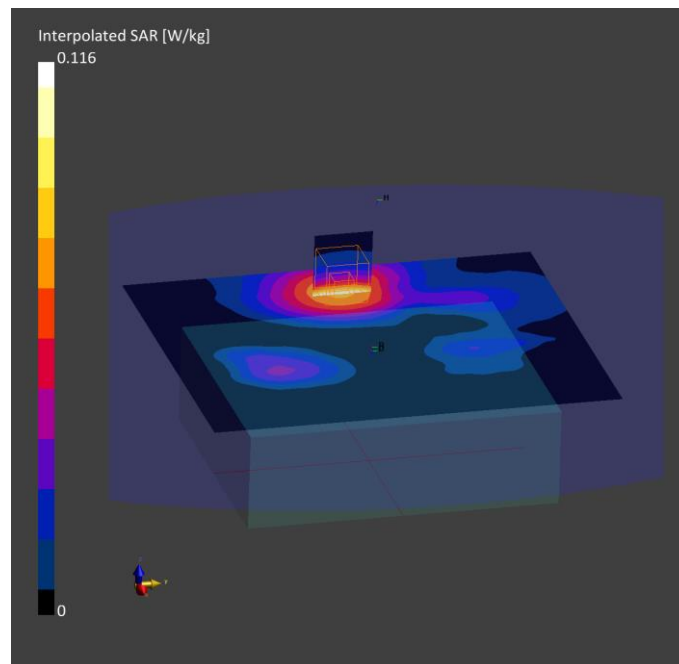

Plot N° 17

Measurement Report for Harman wave, BACK, Band 26 E-UTRA/FDD, UID 10181 CAE, Channel 26865 (831.5MHz)

Device under Test Properties

Model, Manufacturer	Dimensions [mm]	IMEI	DUT Type
Harman wave,	160.0 x 135.0 x 50.0		TCU

Exposure Conditions

Phantom Section, TSL	Position, Test Distance [mm]	Band	Group, UID	Frequency [MHz], Channel Number	Conversion Factor	TSL Conductivity [S/m]	TSL Permittivity
Flat, HSL	BACK, 10.00	Band 26 E-UTRA/FDD	LTE-FDD, 10181-CAE	831.5, 26865	6.12	0.883	41.0

Hardware Setup

Phantom	TSL, Measured Date	Probe, Calibration Date	DAE, Calibration Date
ELI V4.0 (20deg probe tilt) - 1060	HSL900V2 - 2021-10-27 , --	ES3DV3 - SN3052, 2021-09-22	DAE4 Sn1690, 2021-09-08

Scan Setup

	Area Scan	Zoom Scan
Grid Extents [mm]	180.0 x 210.0	30.0 x 30.0 x 30.0
Grid Steps [mm]	15.0 x 15.0	6.0 x 6.0 x 1.5
Sensor Surface [mm]	3.0	3.0
Graded Grid	Yes	Yes
Grading Ratio	1.5	1.5
MAIA	N/A	N/A
Surface Detection	VMS + 6p	VMS + 6p
Scan Method	Measured	Measured

Measurement Results

	Area Scan	Zoom Scan
Date	2021-10-28, 10:37	2021-10-28, 10:43
psSAR1g [W/kg]	0.167	0.174
psSAR10g [W/kg]	0.116	0.125
Power Drift [dB]	0.02	-0.01
Power Scaling	Disabled	Disabled
Scaling Factor [dB]		
TSL Correction	No correction	No correction
M2/M1 [%]		89.4
Dist 3dB Peak [mm]		> 15.0

Warning(s) / Error(s)

Details	Area Scan	Zoom Scan
Warning(s)		
Error(s)		

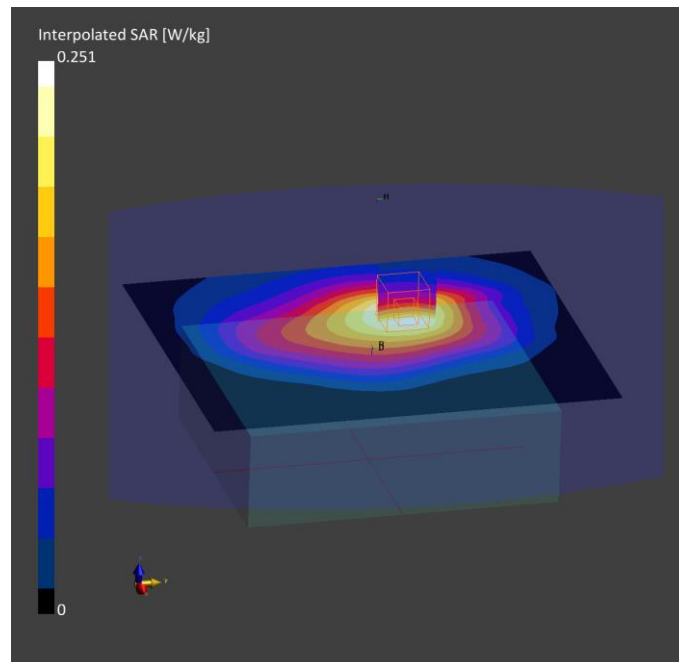

Plot N° 18

Measurement Report for Harman wave, BACK, Band 41, E-UTRA/TDD, UID 10435 AAF, Channel 39750 (2506.0MHz)

Device under Test Properties

Model, Manufacturer	Dimensions [mm]	IMEI	DUT Type
Harman wave,	160.0 x 135.0 x 50.0	350117360052896	TCU

Exposure Conditions

Phantom Section, TSL	Position, Test Distance [mm]	Band	Group, UID	Frequency [MHz], Channel Number	Conversion Factor	TSL Conductivity [S/m]	TSL Permittivity
Flat, HSL	BACK, 10.00	Band 41, E-UTRA/TDD	LTE-TDD, 10435-AAF	2506.0, 39750	7.27	1.94	39.0

Hardware Setup

Phantom	TSL, Measured Date	Probe, Calibration Date	DAE, Calibration Date
ELI V4.0 (20deg probe tilt) - 1060	HBBL1900-3800V3-2600MHz-2021-12-09 , --	EX3DV4 - SN7461, 2020-08-28	DAE4 Sn669, 2021-09-13

Scan Setup

	Area Scan	Zoom Scan
Grid Extents [mm]	180.0 x 200.0	30.0 x 30.0 x 30.0
Grid Steps [mm]	10.0 x 10.0	5.0 x 5.0 x 1.5
Sensor Surface [mm]	3.0	1.4
Graded Grid	Yes	Yes
Grading Ratio	1.5	1.5
MAIA	Y	Y
Surface Detection	VMS + 6p	VMS + 6p
Scan Method	Measured	Measured

Measurement Results

	Area Scan	Zoom Scan
Date	2021-12-11, 12:46	2021-12-11, 12:53
psSAR1g [W/kg]	0.071	0.069
psSAR10g [W/kg]	0.037	0.034
Power Drift [dB]	-0.02	-0.05
Power Scaling	Disabled	Disabled
Scaling Factor [dB]		
TSL Correction	No correction	No correction
M2/M1 [%]		77.8
Dist 3dB Peak [mm]		14.6

Warning(s) / Error(s)

Details	Area Scan	Zoom Scan
Warning(s)		
Error(s)		

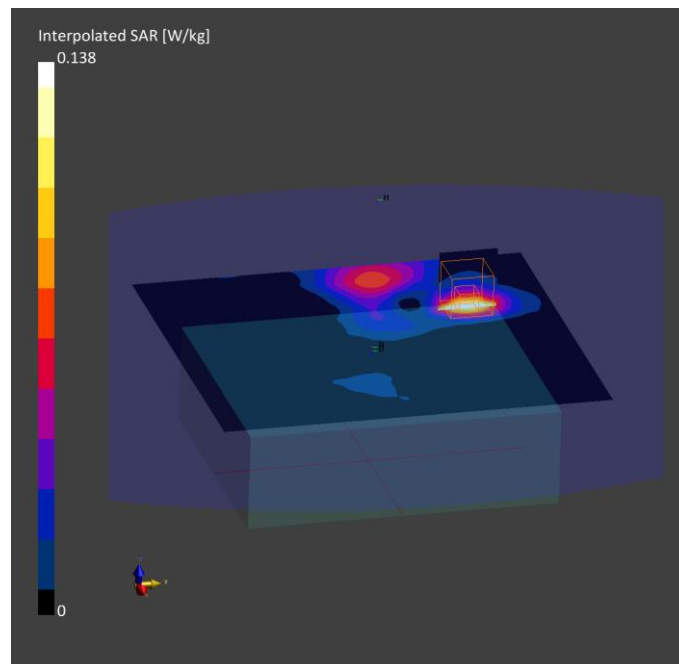

Plot N° 19

Measurement Report for Harman wave, BACK, Band 42, E-UTRA/TDD, UID 10435 AAF, Channel 41690 (3410.0MHz)

Device under Test Properties

Model, Manufacturer	Dimensions [mm]	IMEI	DUT Type
Harman wave,	160.0 x 135.0 x 50.0	350117360052896	TCU

Exposure Conditions

Phantom Section, TSL	Position, Test Distance [mm]	Band	Group, UID	Frequency [MHz], Channel Number	Conversion Factor	TSL Conductivity [S/m]	TSL Permittivity
Flat, HSL	BACK, 10.00	Band 42, E-UTRA/TDD	LTE-TDD, 10435-AAF	3410.0, 41690	7.1	2.86	39.3

Hardware Setup

Phantom	TSL, Measured Date	Probe, Calibration Date	DAE, Calibration Date
ELI V4.0 (20deg probe tilt) - 1060	HBBL3500-5800V5-3500MHz-2021-12-22 , --	EX3DV4 - SN7461, 2020-08-28	DAE4 Sn669, 2021-09-13

Scan Setup

	Area Scan	Zoom Scan
Grid Extents [mm]	180.0 x 200.0	28.0 x 28.0 x 28.0
Grid Steps [mm]	10.0 x 10.0	5.0 x 5.0 x 1.4
Sensor Surface [mm]	3.0	1.4
Graded Grid	Yes	Yes
Grading Ratio	1.5	1.5
MAIA	Y	Y
Surface Detection	VMS + 6p	VMS + 6p
Scan Method	Measured	Measured

Measurement Results

	Area Scan	Zoom Scan
Date	2021-12-23, 11:09	2021-12-23, 11:16
psSAR1g [W/kg]	0.012	0.011
psSAR10g [W/kg]	0.006	0.005
Power Drift [dB]	0.15	0.10
Power Scaling	Disabled	Disabled
Scaling Factor [dB]		
TSL Correction	No correction	No correction
M2/M1 [%]		82.4
Dist 3dB Peak [mm]		> 14.0

Warning(s) / Error(s)

Details	Area Scan	Zoom Scan
Warning(s)		
Error(s)		

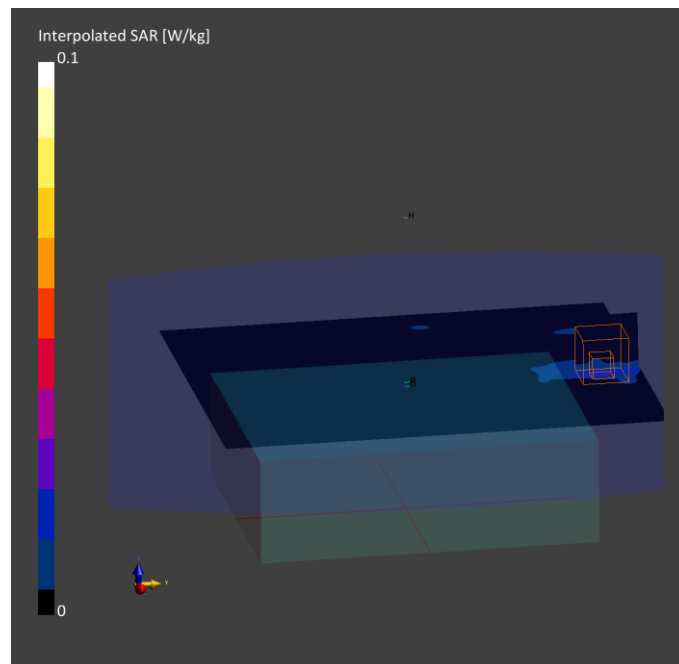

Plot Nº 20

Measurement Report for Harman wave, BACK, Band 42, E-UTRA/TDD, UID 10435 AAF, Channel 41690 (3410.0MHz)

Device under Test Properties

Model, Manufacturer	Dimensions [mm]	IMEI	DUT Type
Harman wave,	160.0 x 135.0 x 50.0	350117360052896	TCU

Exposure Conditions

Phantom Section, TSL	Position, Test Distance [mm]	Band	Group, UID	Frequency [MHz], Channel Number	Conversion Factor	TSL Conductivity [S/m]	TSL Permittivity
Flat, HSL	BACK, 10.00	Band 42, E-UTRA/TDD	LTE-TDD, 10435-AAF	3410.0, 41690	7.1	2.86	39.3

Hardware Setup

Phantom	TSL, Measured Date	Probe, Calibration Date	DAE, Calibration Date
ELI V4.0 (20deg probe tilt) - 1060	HBBL3500-5800V5-3500MHz-2021-12-22, --	EX3DV4 - SN7461, 2020-08-28	DAE4 Sn669, 2021-09-13

Scan Setup

	Area Scan	Zoom Scan
Grid Extents [mm]	180.0 x 200.0	28.0 x 28.0 x 28.0
Grid Steps [mm]	10.0 x 10.0	5.0 x 5.0 x 1.4
Sensor Surface [mm]	3.0	1.4
Graded Grid	Yes	Yes
Grading Ratio	1.5	1.5
MAIA	Y	Y
Surface Detection	VMS + 6p	VMS + 6p
Scan Method	Measured	Measured

Measurement Results

	Area Scan	Zoom Scan
Date	2021-12-23, 08:08	2021-12-23, 08:17
psSAR1g [W/kg]	0.006	0.007
psSAR10g [W/kg]	0.003	0.002
Power Drift [dB]	0.21	0.08
Power Scaling	Disabled	Disabled
Scaling Factor [dB]		
TSL Correction	No correction	No correction
M2/M1 [%]		74.6
Dist 3dB Peak [mm]		> 14.0

Warning(s) / Error(s)

Details	Area Scan	Zoom Scan
Warning(s)		
Error(s)		

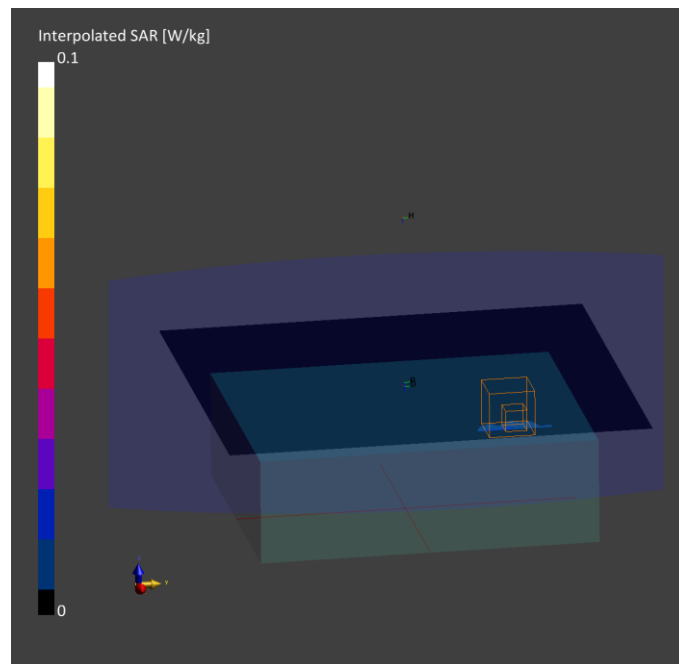

Plot Nº 21

Measurement Report for Harman wave, BACK, Band 66, E-UTRA/FDD, UID 10169 CAE, Channel 132572 (1770.0MHz)

Device under Test Properties

Model, Manufacturer	Dimensions [mm]	IMEI	DUT Type
Harman wave,	160.0 x 135.0 x 50.0		TCU

Exposure Conditions

Phantom Section, TSL	Position, Test Distance [mm]	Band	Group, UID	Frequency [MHz], Channel Number	Conversion Factor	TSL Conductivity [S/m]	TSL Permittivity
Flat, HSL	BACK, 10.00	Band 66, E-UTRA/FDD	LTE-FDD, 10169-CAE	1770.0, 132572	5.28	1.43	38.7

Hardware Setup

Phantom	TSL, Measured Date	Probe, Calibration Date	DAE, Calibration Date
ELI V4.0 (20deg probe tilt) - 1060	HBBL1350-1850V3-1700MHz-2021-11-02, --	ES3DV3 - SN3052, 2021-09-22	DAE4 Sn1690, 2021-09-08

Scan Setup

	Area Scan	Zoom Scan
Grid Extents [mm]	180.0 x 210.0	30.0 x 30.0 x 30.0
Grid Steps [mm]	15.0 x 15.0	6.0 x 6.0 x 1.5
Sensor Surface [mm]	3.0	3.0
Graded Grid	Yes	Yes
Grading Ratio	1.5	1.5
MAIA	Y	Y
Surface Detection	VMS + 6p	VMS + 6p
Scan Method	Measured	Measured

Measurement Results

	Area Scan	Zoom Scan
Date	2021-11-02, 12:29	2021-11-02, 12:35
psSAR1g [W/kg]	0.062	0.062
psSAR10g [W/kg]	0.036	0.036
Power Drift [dB]	0.00	-0.07
Power Scaling	Disabled	Disabled
Scaling Factor [dB]		
TSL Correction	No correction	No correction
M2/M1 [%]		86.7
Dist 3dB Peak [mm]		> 15.0

Warning(s) / Error(s)

Details	Area Scan	Zoom Scan
Warning(s)		
Error(s)		

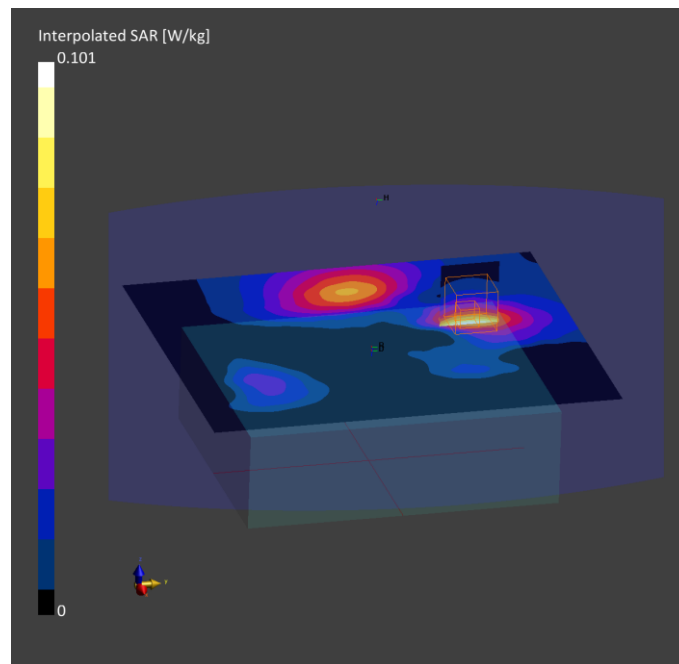

Plot N° 22

Measurement Report for Harman wave, BACK, Band 71, E-UTRA/FDD, UID 10169 CAE, Channel 133372 (688.0MHz)

Device under Test Properties

Model, Manufacturer	Dimensions [mm]	IMEI	DUT Type
Harman wave,	160.0 x 135.0 x 50.0	350117360051443	TCU

Exposure Conditions

Phantom Section, TSL	Position, Test Distance [mm]	Band	Group, UID	Frequency [MHz], Channel Number	Conversion Factor	TSL Conductivity [S/m]	TSL Permittivity
Flat, HSL	BACK, 10.00	Band 71, E-UTRA/FDD	LTE-FDD, 10169-CAE	688.0, 133372	9.84	0.850	42.8

Hardware Setup

Phantom	TSL, Measured Date	Probe, Calibration Date	DAE, Calibration Date
ELI V4.0 (20deg probe tilt) - 1060	HSL750V2-2021-11-24 , --	EX3DV4 - SN7461, 2020-08-28	DAE4 Sn669, 2021-09-13

Scan Setup

	Area Scan	Zoom Scan
Grid Extents [mm]	180.0 x 210.0	30.0 x 30.0 x 30.0
Grid Steps [mm]	15.0 x 15.0	6.0 x 6.0 x 1.5
Sensor Surface [mm]	3.0	1.4
Graded Grid	Yes	Yes
Grading Ratio	1.5	1.5
MAIA	Y	Y
Surface Detection	VMS + 6p	All points
Scan Method	Measured	Measured

Measurement Results

	Area Scan	Zoom Scan
Date	2021-11-25, 10:02	2021-11-25, 10:14
psSAR1g [W/kg]	0.071	0.070
psSAR10g [W/kg]	0.050	0.052
Power Drift [dB]	-0.26	0.10
Power Scaling	Disabled	Disabled
Scaling Factor [dB]		
TSL Correction	No correction	No correction
M2/M1 [%]		87.5
Dist 3dB Peak [mm]		> 15.0

Warning(s) / Error(s)

Details	Area Scan	Zoom Scan
Warning(s)		
Error(s)		

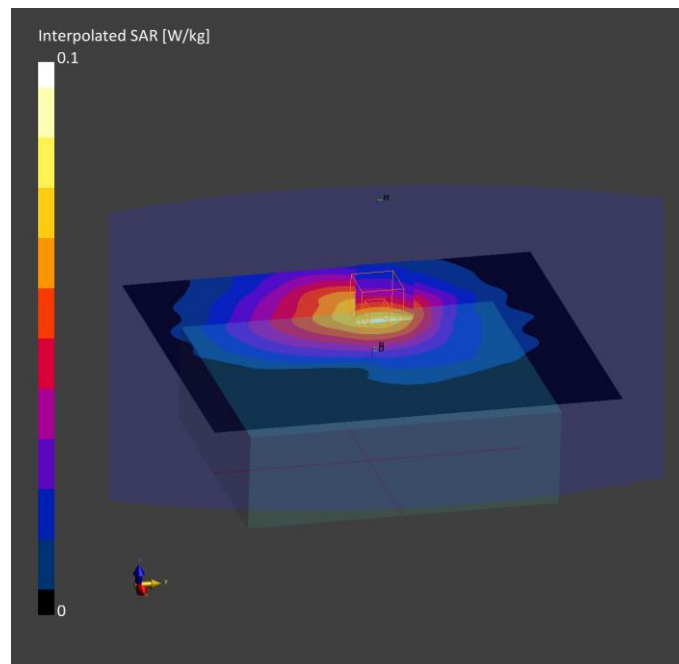

Plot N° 23

Measurement Report for Harman wave, BACK, Band 5, E-UTRA/FDD, UID 10177 CAI, Channel 20528 (836.8MHz)

Device under Test Properties

Model, Manufacturer	Dimensions [mm]	IMEI	DUT Type
Harman wave,	160.0 x 135.0 x 50.0		TCU

Exposure Conditions

Phantom Section, TSL	Position, Test Distance [mm]	Band	Group, UID	Frequency [MHz], Channel Number	Conversion Factor	TSL Conductivity [S/m]	TSL Permittivity
Flat, HSL	BACK, 10.00	Band 5, E-UTRA/FDD	LTE-FDD, 10177-CAI	836.8, 20528	6.12	0.900	41.4

Hardware Setup

Phantom	TSL, Measured Date	Probe, Calibration Date	DAE, Calibration Date
ELI V4.0 (20deg probe tilt) - 1060	HSL900V2_Head-11-11-2021, --	ES3DV3 - SN3052, 2021-09-22	DAE4 Sn1690, 2021-09-08

Scan Setup

	Area Scan	Zoom Scan
Grid Extents [mm]	180.0 x 210.0	30.0 x 30.0 x 30.0
Grid Steps [mm]	15.0 x 15.0	6.0 x 6.0 x 1.5
Sensor Surface [mm]	3.0	3.0
Graded Grid	Yes	Yes
Grading Ratio	1.5	1.5
MAIA	N/A	N/A
Surface Detection	VMS + 6p	VMS + 6p
Scan Method	Measured	Measured

Measurement Results

	Area Scan	Zoom Scan
Date	2021-11-12, 13:45	2021-11-12, 13:51
psSAR1g [W/kg]	0.204	0.211
psSAR10g [W/kg]	0.143	0.153
Power Drift [dB]	-0.21	0.23
Power Scaling	Disabled	Disabled
Scaling Factor [dB]		
TSL Correction	No correction	No correction
M2/M1 [%]		90.9
Dist 3dB Peak [mm]		> 15.0

Warning(s) / Error(s)

Details	Area Scan	Zoom Scan
Warning(s)		
Error(s)		

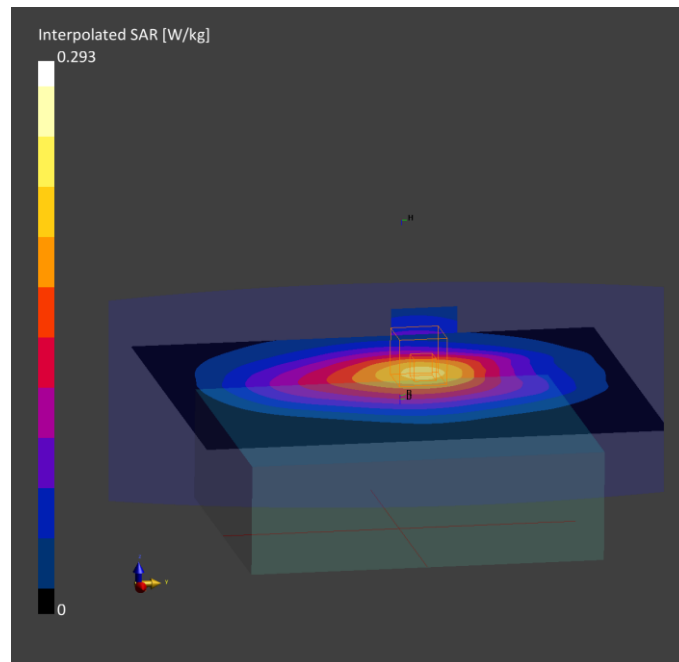

Plot N° 24

Measurement Report for Harman wave, BACK, Band 7, E-UTRA/FDD, UID 10169 CAE, Channel 20850 (2510.0MHz)

Device under Test Properties

Model, Manufacturer	Dimensions [mm]	IMEI	DUT Type
Harman wave,	160.0 x 135.0 x 50.0	350117360052896	TCU

Exposure Conditions

Phantom Section, TSL	Position, Test Distance [mm]	Band	Group, UID	Frequency [MHz], Channel Number	Conversion Factor	TSL Conductivity [S/m]	TSL Permittivity
Flat, HSL	BACK, 10.00	Band 7, E-UTRA/FDD	LTE-FDD, 10169-CAE	2510.0, 20850	7.27	1.94	39.0

Hardware Setup

Phantom	TSL, Measured Date	Probe, Calibration Date	DAE, Calibration Date
ELI V4.0 (20deg probe tilt) - 1060	HBBL1900-3800V3-2600MHz-2021-12-09 , --	EX3DV4 - SN7461, 2020-08-28	DAE4 Sn669, 2021-09-13

Scan Setup

	Area Scan	Zoom Scan
Grid Extents [mm]	180.0 x 200.0	30.0 x 30.0 x 30.0
Grid Steps [mm]	10.0 x 10.0	5.0 x 5.0 x 1.5
Sensor Surface [mm]	3.0	1.4
Graded Grid	Yes	Yes
Grading Ratio	1.5	1.5
MAIA	Y	Y
Surface Detection	VMS + 6p	VMS + 6p
Scan Method	Measured	Measured

Measurement Results

	Area Scan	Zoom Scan
Date	2021-12-11, 13:49	2021-12-11, 13:57
psSAR1g [W/kg]	0.098	0.096
psSAR10g [W/kg]	0.050	0.048
Power Drift [dB]	-0.06	-0.12
Power Scaling	Disabled	Disabled
Scaling Factor [dB]		
TSL Correction	No correction	No correction
M2/M1 [%]		78.2
Dist 3dB Peak [mm]		14.1

Warning(s) / Error(s)

Details	Area Scan	Zoom Scan
Warning(s)		
Error(s)		

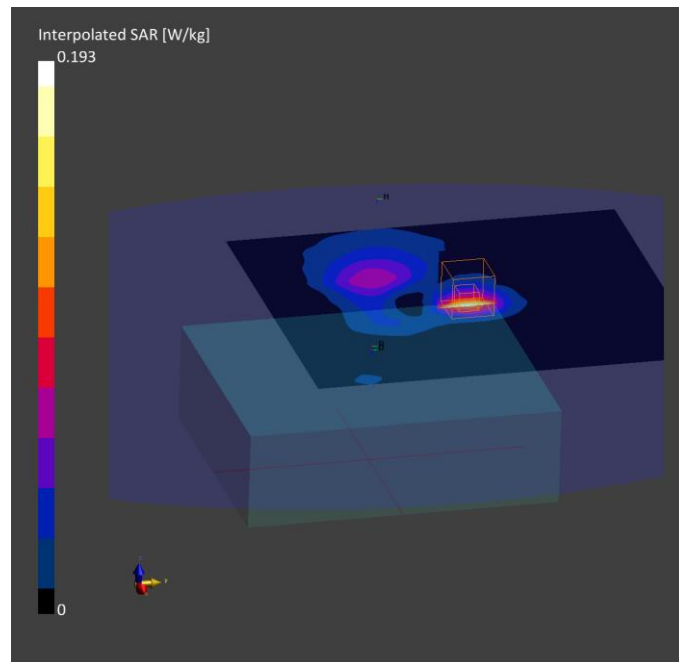

Plot Nº 25

Measurement Report for Harman wave, BACK, Band 41, E-UTRA/TDD, UID 10435 AAF, Channel 39750 (2506.0MHz)

Device under Test Properties

Model, Manufacturer	Dimensions [mm]	IMEI	DUT Type
Harman wave,	160.0 x 135.0 x 50.0	350117360052896	TCU

Exposure Conditions

Phantom Section, TSL	Position, Test Distance [mm]	Band	Group, UID	Frequency [MHz], Channel Number	Conversion Factor	TSL Conductivity [S/m]	TSL Permittivity
Flat, HSL	BACK, 10.00	Band 41, E-UTRA/TDD	LTE-TDD, 10435-AAF	2506.0, 39750	7.27	1.94	39.0

Hardware Setup

Phantom	TSL, Measured Date	Probe, Calibration Date	DAE, Calibration Date
ELI V4.0 (20deg probe tilt) - 1060	HBBL1900-3800V3-2600MHz-2021-12-09 , --	EX3DV4 - SN7461, 2020-08-28	DAE4 Sn669, 2021-09-13

Scan Setup

	Area Scan	Zoom Scan
Grid Extents [mm]	180.0 x 200.0	30.0 x 30.0 x 30.0
Grid Steps [mm]	10.0 x 10.0	5.0 x 5.0 x 1.5
Sensor Surface [mm]	3.0	1.4
Graded Grid	Yes	Yes
Grading Ratio	1.5	1.5
MAIA	Y	Y
Surface Detection	VMS + 6p	VMS + 6p
Scan Method	Measured	Measured

Measurement Results

	Area Scan	Zoom Scan
Date	2021-12-11, 09:06	2021-12-11, 09:13
psSAR1g [W/kg]	0.073	0.069
psSAR10g [W/kg]	0.038	0.034
Power Drift [dB]	0.01	-0.03
Power Scaling	Disabled	Disabled
Scaling Factor [dB]		
TSL Correction	No correction	No correction
M2/M1 [%]		77.4
Dist 3dB Peak [mm]		14.0

Warning(s) / Error(s)

Details	Area Scan	Zoom Scan
Warning(s)		
Error(s)		

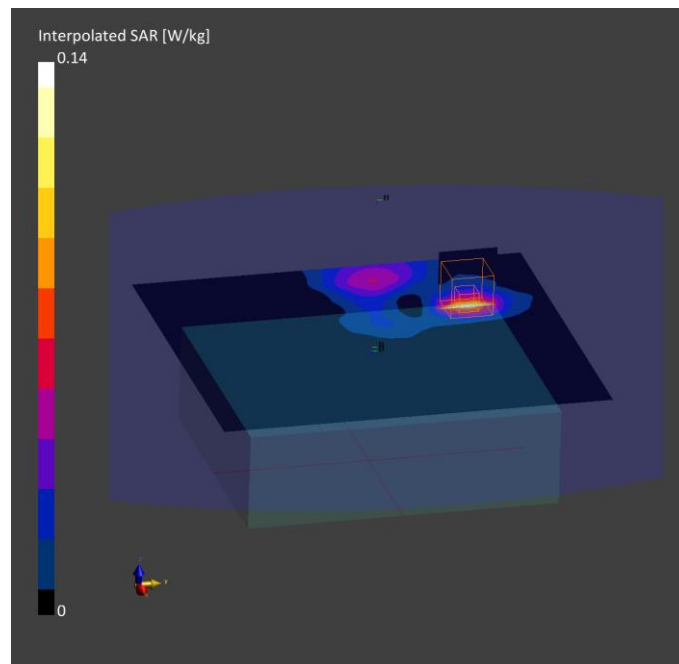

Plot Nº 26

Measurement Report for Harman wave, BACK, Band 42, E-UTRA/TDD, UID 10435 AAF, Channel 42565 (3497.5MHz)

Device under Test Properties

Model, Manufacturer	Dimensions [mm]	IMEI	DUT Type
Harman wave,	160.0 x 135.0 x 50.0	350117360052896	TCU

Exposure Conditions

Phantom Section, TSL	Position, Test Distance [mm]	Band	Group, UID	Frequency [MHz], Channel Number	Conversion Factor	TSL Conductivity [S/m]	TSL Permittivity
Flat, HSL	BACK, 0.00	Band 42, E-UTRA/TDD	LTE-TDD, 10435-AAF	3497.5, 42565	7.1	2.94	39.2

Hardware Setup

Phantom	TSL, Measured Date	Probe, Calibration Date	DAE, Calibration Date
ELI V4.0 (20deg probe tilt) - 1060	HBBL3500-5800V5-3500MHz-2021-12-22, --	EX3DV4 - SN7461, 2020-08-28	DAE4 Sn669, 2021-09-13

Scan Setup

	Area Scan	Zoom Scan
Grid Extents [mm]	180.0 x 200.0	28.0 x 28.0 x 28.0
Grid Steps [mm]	10.0 x 10.0	5.0 x 5.0 x 1.4
Sensor Surface [mm]	3.0	1.4
Graded Grid	Yes	Yes
Grading Ratio	1.5	1.5
MAIA	Y	Y
Surface Detection	VMS + 6p	VMS + 6p
Scan Method	Measured	Measured

Measurement Results

	Area Scan	Zoom Scan
Date	2021-12-22, 11:03	2021-12-22, 11:12
psSAR1g [W/kg]	0.024	0.021
psSAR10g [W/kg]	0.01	0.005
Power Drift [dB]	-0.12	-0.07
Power Scaling	Disabled	Disabled
Scaling Factor [dB]		
TSL Correction	No correction	No correction
M2/M1 [%]		80.9
Dist 3dB Peak [mm]		> 14.0

Warning(s) / Error(s)

Details	Area Scan	Zoom Scan
Warning(s)		
Error(s)		

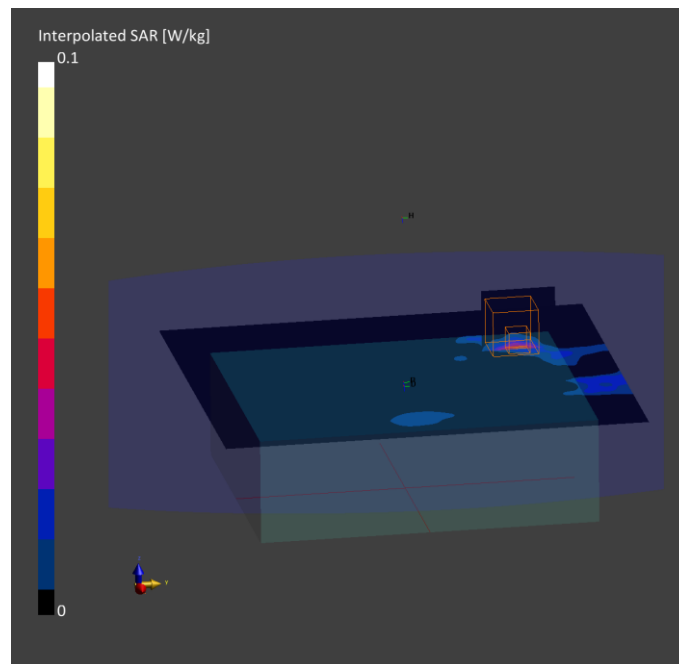

Plot N° 27

Measurement Report for Harman wave, BACK, Band 66, E-UTRA/FDD, UID 10175 CAG, Channel 132572 (1770.0MHz)

Device under Test Properties

Model, Manufacturer	Dimensions [mm]	IMEI	DUT Type
Harman wave,	160.0 x 135.0 x 50.0	350117360052896	TCU

Exposure Conditions

Phantom Section, TSL	Position, Test Distance [mm]	Band	Group, UID	Frequency [MHz], Channel Number	Conversion Factor	TSL Conductivity [S/m]	TSL Permittivity
Flat, HSL	BACK, 10.00	Band 66, E-UTRA/FDD	LTE-FDD, 10175-CAG	1770.0, 132572	5.28	1.40	38.7

Hardware Setup

Phantom	TSL, Measured Date	Probe, Calibration Date	DAE, Calibration Date
ELI V4.0 (20deg probe tilt) - 1060	HBBL1350-1850V3-1700MHz-2021-11-30 , --	ES3DV3 - SN3052, 2021-09-22	DAE4 Sn1690, 2021-09-08

Scan Setup

	Area Scan	Zoom Scan
Grid Extents [mm]	180.0 x 210.0	30.0 x 30.0 x 30.0
Grid Steps [mm]	15.0 x 15.0	6.0 x 6.0 x 1.5
Sensor Surface [mm]	3.0	3.0
Graded Grid	Yes	Yes
Grading Ratio	1.5	1.5
MAIA	Y	Y
Surface Detection	VMS + 6p	VMS + 6p
Scan Method	Measured	Measured

Measurement Results

	Area Scan	Zoom Scan
Date	2021-12-01, 16:36	2021-12-01, 16:45
psSAR1g [W/kg]	0.075	0.076
psSAR10g [W/kg]	0.047	0.047
Power Drift [dB]	-0.01	-0.05
Power Scaling	Disabled	Disabled
Scaling Factor [dB]		
TSL Correction	No correction	No correction
M2/M1 [%]		88.6
Dist 3dB Peak [mm]		> 15.0

Warning(s) / Error(s)

Details	Area Scan	Zoom Scan
Warning(s)		
Error(s)		

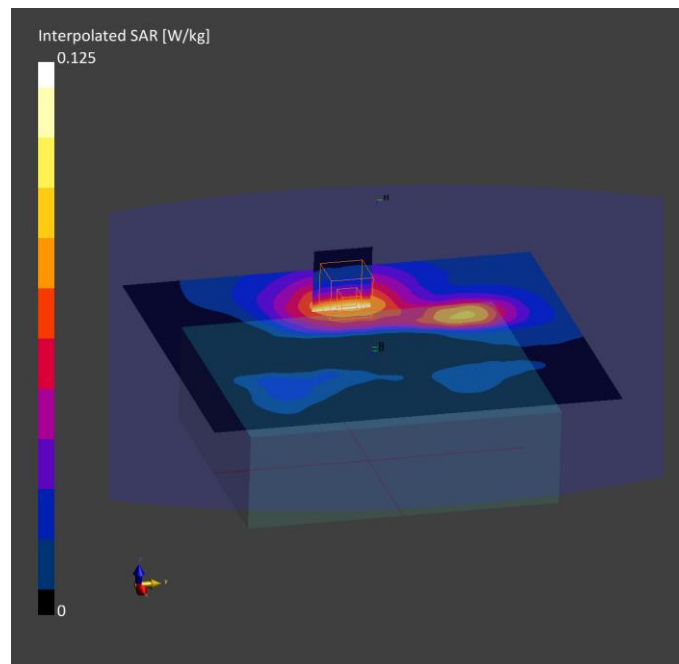

Plot N° 28

Measurement Report for Harman wave, BACK, Band 66, E-UTRA/FDD, UID 10169 CAE, Channel 132522 (1765.0MHz)

Device under Test Properties

Model, Manufacturer	Dimensions [mm]	IMEI	DUT Type
Harman wave,	160.0 x 135.0 x 50.0	350117360052896	TCU

Exposure Conditions

Phantom Section, TSL	Position, Test Distance [mm]	Band	Group, UID	Frequency [MHz], Channel Number	Conversion Factor	TSL Conductivity [S/m]	TSL Permittivity
Flat, HSL	BACK, 10.00	Band 66, E-UTRA/FDD	LTE-FDD, 10169-CAE	1765.0, 132522	5.28	1.40	38.7

Hardware Setup

Phantom	TSL, Measured Date	Probe, Calibration Date	DAE, Calibration Date
ELI V4.0 (20deg probe tilt) - 1060	HBBL1350-1850V3-1700MHz-2021-11-30 , --	ES3DV3 - SN3052, 2021-09-22	DAE4 Sn1690, 2021-09-08

Scan Setup

	Area Scan	Zoom Scan
Grid Extents [mm]	180.0 x 210.0	30.0 x 30.0 x 30.0
Grid Steps [mm]	15.0 x 15.0	6.0 x 6.0 x 1.5
Sensor Surface [mm]	3.0	3.0
Graded Grid	Yes	Yes
Grading Ratio	1.5	1.5
MAIA	Y	Y
Surface Detection	VMS + 6p	VMS + 6p
Scan Method	Measured	Measured

Measurement Results

	Area Scan	Zoom Scan
Date	2021-12-01, 16:57	2021-12-01, 17:06
psSAR1g [W/kg]	0.054	0.054
psSAR10g [W/kg]	0.034	0.033
Power Drift [dB]	0.01	-0.07
Power Scaling	Disabled	Disabled
Scaling Factor [dB]		
TSL Correction	No correction	No correction
M2/M1 [%]		86.1
Dist 3dB Peak [mm]		> 15.0

Warning(s) / Error(s)

Details	Area Scan	Zoom Scan
Warning(s)		
Error(s)		

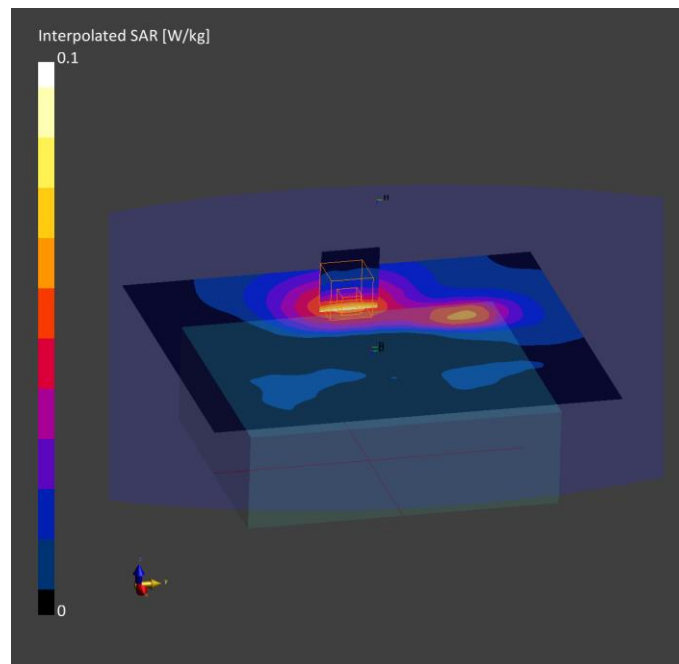

Plot N° 29

Measurement Report for Harman wave, BACK, Band n5, UID 10931 AAB, Channel 167300 (836.5MHz)

Device under Test Properties

Model, Manufacturer	Dimensions [mm]	IMEI	DUT Type
Harman wave,	160.0 x 135.0 x 50.0		TCU

Exposure Conditions

Phantom Section, TSL	Position, Test Distance [mm]	Band	Group, UID	Frequency [MHz], Channel Number	Conversion Factor	TSL Conductivity [S/m]	TSL Permittivity
Flat, HSL	BACK, 10.00	Band n5	5G NR FR1 FDD, 10931-AAB	836.5, 167300	6.12	0.900	41.4

Hardware Setup

Phantom	TSL, Measured Date	Probe, Calibration Date	DAE, Calibration Date
ELI V4.0 (20deg probe tilt) - 1060	HSL900V2_Head-11-11-2021 , --	ES3DV3 - SN3052, 2021-09-22	DAE4 Sn1690, 2021-09-08

Scan Setup

	Area Scan	Zoom Scan
Grid Extents [mm]	180.0 x 210.0	30.0 x 30.0 x 30.0
Grid Steps [mm]	15.0 x 15.0	6.0 x 6.0 x 1.5
Sensor Surface [mm]	3.0	3.0
Graded Grid	Yes	Yes
Grading Ratio	1.5	1.5
MAIA	Y	Y
Surface Detection	VMS + 6p	VMS + 6p
Scan Method	Measured	Measured

Measurement Results

	Area Scan	Zoom Scan
Date	2021-11-11, 11:01	2021-11-11, 11:07
psSAR1g [W/kg]	0.079	0.084
psSAR10g [W/kg]	0.055	0.060
Power Drift [dB]	0.05	0.01
Power Scaling	Disabled	Disabled
Scaling Factor [dB]		
TSL Correction	No correction	No correction
M2/M1 [%]		90.1
Dist 3dB Peak [mm]		> 15.0

Warning(s) / Error(s)

Details	Area Scan	Zoom Scan
Warning(s)		
Error(s)		

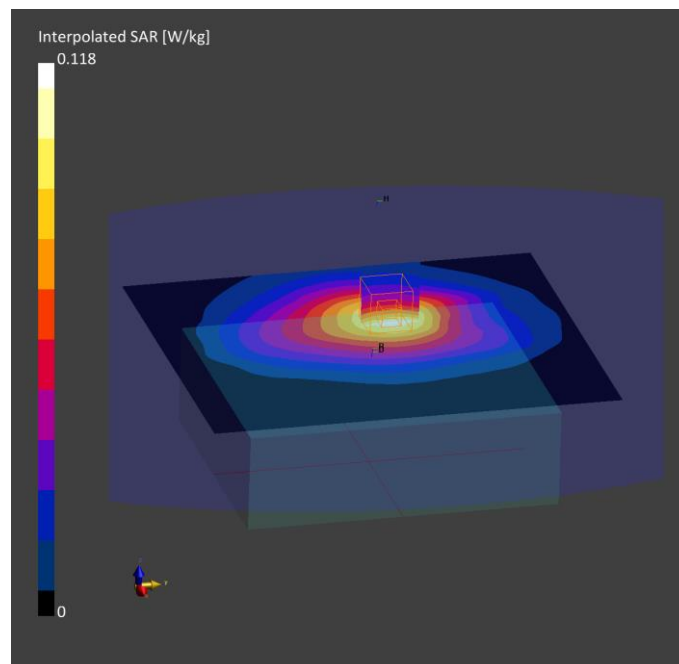

Plot Nº 30

Measurement Report for Harman wave, BACK, Band n7, UID 10931 AAB, Channel 502000 (2510.0MHz)

Device under Test Properties

Model, Manufacturer	Dimensions [mm]	IMEI	DUT Type
Harman wave,	160.0 x 135.0 x 50.0	350117360052896	TCU

Exposure Conditions

Phantom Section, TSL	Position, Test Distance [mm]	Band	Group, UID	Frequency [MHz], Channel Number	Conversion Factor	TSL Conductivity [S/m]	TSL Permittivity
Flat, HSL	BACK, 10.00	Band n7	5G NR FR1 FDD, 10931-AAB	2510.0, 502000	7.27	1.94	39.0

Hardware Setup

Phantom	TSL, Measured Date	Probe, Calibration Date	DAE, Calibration Date
ELI V4.0 (20deg probe tilt) - 1060	HBBL1900-3800V3-2600MHz-2021-12-09 , --	EX3DV4 - SN7461, 2020-08-28	DAE4 Sn669, 2021-09-13

Scan Setup

	Area Scan	Zoom Scan
Grid Extents [mm]	180.0 x 200.0	30.0 x 30.0 x 30.0
Grid Steps [mm]	10.0 x 10.0	5.0 x 5.0 x 1.5
Sensor Surface [mm]	3.0	1.4
Graded Grid	Yes	Yes
Grading Ratio	1.5	1.5
MAIA	Y	Y
Surface Detection	VMS + 6p	VMS + 6p
Scan Method	Measured	Measured

Measurement Results

	Area Scan	Zoom Scan
Date	2021-12-10, 19:06	2021-12-10, 19:13
psSAR1g [W/kg]	0.067	0.064
psSAR10g [W/kg]	0.035	0.032
Power Drift [dB]	-0.02	-0.00
Power Scaling	Disabled	Disabled
Scaling Factor [dB]		
TSL Correction	No correction	No correction
M2/M1 [%]		78.8
Dist 3dB Peak [mm]		11.7

Warning(s) / Error(s)

Details	Area Scan	Zoom Scan
Warning(s)		
Error(s)		

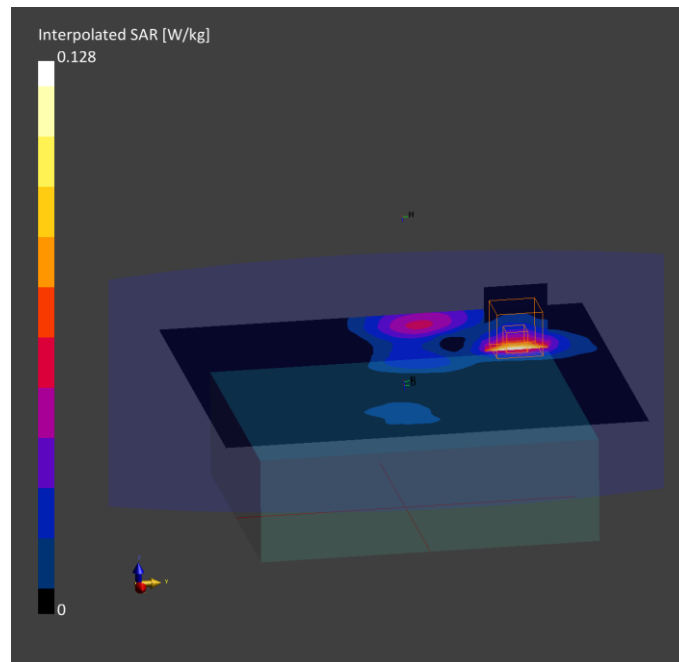

Plot Nº 31

Measurement Report for Harman wave, BACK, Band n25, UID 10931 AAB, Channel 374000 (1870.0MHz)

Device under Test Properties

Model, Manufacturer	Dimensions [mm]	IMEI	DUT Type
Harman wave,	160.0 x 135.0 x 50.0		TCU

Exposure Conditions

Phantom Section, TSL	Position, Test Distance [mm]	Band	Group, UID	Frequency [MHz], Channel Number	Conversion Factor	TSL Conductivity [S/m]	TSL Permittivity
Flat, HSL	BACK, 10.00	Band n25	5G NR FR1 FDD, 10931-AAB	1870.0, 374000	8.25	1.42	39.3

Hardware Setup

Phantom	TSL, Measured Date	Probe, Calibration Date	DAE, Calibration Date
ELI V4.0 (20deg probe tilt) - 1060	HBBL1550-1950V3_Head-27-12-2021, --	EX3DV4 - SN7461, 2020-08-28	DAE4 Sn669, 2021-09-13

Scan Setup

	Area Scan	Zoom Scan
Grid Extents [mm]	180.0 x 210.0	30.0 x 30.0 x 30.0
Grid Steps [mm]	15.0 x 15.0	6.0 x 6.0 x 1.5
Sensor Surface [mm]	3.0	1.4
Graded Grid	Yes	Yes
Grading Ratio	1.5	1.5
MAIA	Y	Y
Surface Detection	VMS + 6p	VMS + 6p
Scan Method	Measured	Measured

Measurement Results

	Area Scan	Zoom Scan
Date	2021-12-27, 10:05	2021-12-27, 10:11
psSAR1g [W/kg]	0.027	0.028
psSAR10g [W/kg]	0.016	0.017
Power Drift [dB]	0.15	-0.04
Power Scaling	Disabled	Disabled
Scaling Factor [dB]		
TSL Correction	No correction	No correction
M2/M1 [%]		87.2
Dist 3dB Peak [mm]		> 15.0

Warning(s) / Error(s)

Details	Area Scan	Zoom Scan
Warning(s)		
Error(s)		

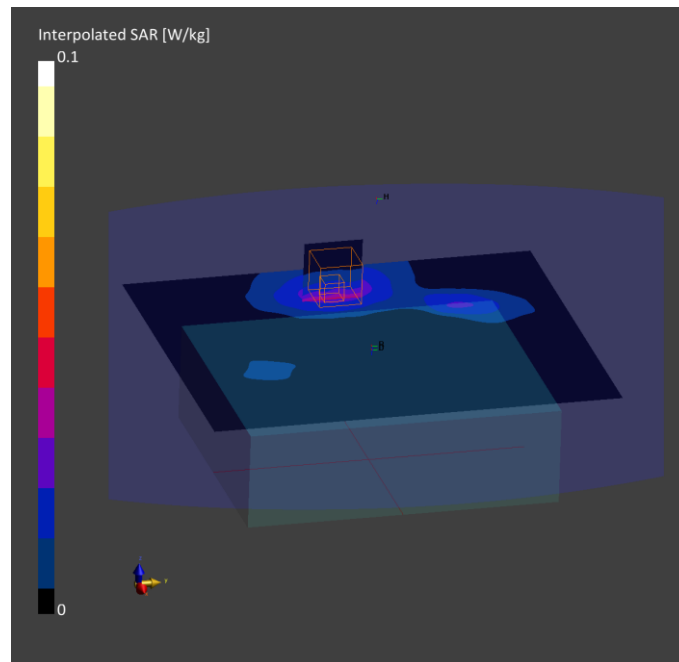

Plot N° 32

Measurement Report for Harman wave, BACK, Band n38, UID 10770 AAD, Channel 519000 (2595.0MHz)

Device under Test Properties

Model, Manufacturer	Dimensions [mm]	IMEI	DUT Type
Harman wave,	160.0 x 135.0 x 50.0	350117360052896	TCU

Exposure Conditions

Phantom Section, TSL	Position, Test Distance [mm]	Band	Group, UID	Frequency [MHz], Channel Number	Conversion Factor	TSL Conductivity [S/m]	TSL Permittivity
Flat, HSL	BACK, 10.00	Band n38	5G NR FR1 TDD, 10770-AAD	2595.0, 519000	7.27	1.94	39.5

Hardware Setup

Phantom	TSL, Measured Date	Probe, Calibration Date	DAE, Calibration Date
ELI V4.0 (20deg probe tilt) - 1060	HBBL1900-3800V3-2300-2600MHz-2021-12-15 , --	EX3DV4 - SN7461, 2020-08-28	DAE4 Sn669, 2021-09-13

Scan Setup

	Area Scan	Zoom Scan
Grid Extents [mm]	180.0 x 200.0	30.0 x 30.0 x 30.0
Grid Steps [mm]	10.0 x 10.0	5.0 x 5.0 x 1.5
Sensor Surface [mm]	3.0	1.4
Graded Grid	Yes	Yes
Grading Ratio	1.5	1.5
MAIA	Y	Y
Surface Detection	VMS + 6p	VMS + 6p
Scan Method	Measured	Measured

Measurement Results

	Area Scan	Zoom Scan
Date	2021-12-16, 20:08	2021-12-16, 20:18
psSAR1g [W/kg]	0.020	0.020
psSAR10g [W/kg]	0.008	0.007
Power Drift [dB]	-0.03	0.30
Power Scaling	Disabled	Disabled
Scaling Factor [dB]		
TSL Correction	No correction	No correction
M2/M1 [%]		87.4
Dist 3dB Peak [mm]		> 15.0

Warning(s) / Error(s)

Details	Area Scan	Zoom Scan
Warning(s)		
Error(s)		

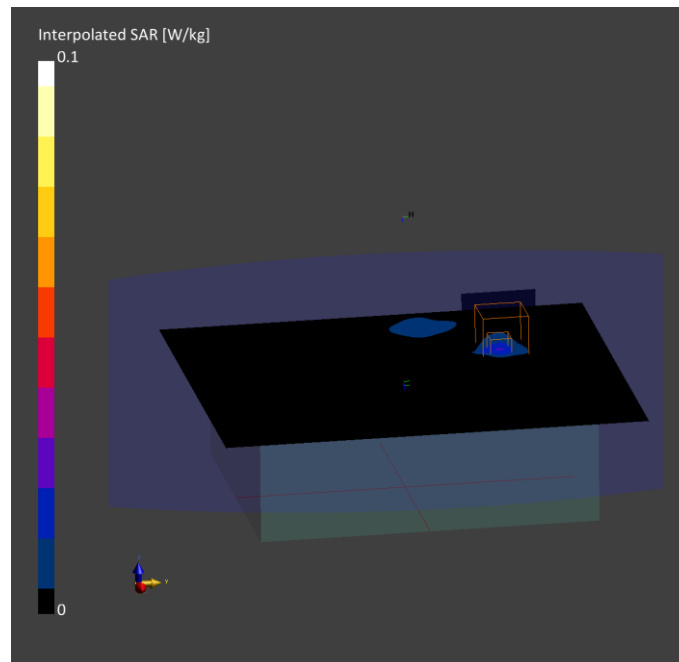

Plot N° 33

Measurement Report for Harman wave, BACK, Band n41, UID 10866 AAD, Channel 509202 (2546.0MHz)

Device under Test Properties

Model, Manufacturer	Dimensions [mm]	IMEI	DUT Type
Harman wave,	160.0 x 135.0 x 50.0	350117360052896	TCU

Exposure Conditions

Phantom Section, TSL	Position, Test Distance [mm]	Band	Group, UID	Frequency [MHz], Channel Number	Conversion Factor	TSL Conductivity [S/m]	TSL Permittivity
Flat, HSL	BACK, 0.00	Band n41	5G NR FR1 TDD, 10866-AAD	2546.0, 509202	7.27	1.97	38.9

Hardware Setup

Phantom	TSL, Measured Date	Probe, Calibration Date	DAE, Calibration Date
ELI V4.0 (20deg probe tilt) - 1060	HBBL1900-3800V3-2600MHz-2021-12-09 , --	EX3DV4 - SN7461, 2020-08-28	DAE4 Sn669, 2021-09-13

Scan Setup

	Area Scan	Zoom Scan
Grid Extents [mm]	180.0 x 200.0	30.0 x 30.0 x 30.0
Grid Steps [mm]	10.0 x 10.0	5.0 x 5.0 x 1.5
Sensor Surface [mm]	3.0	1.4
Graded Grid	Yes	Yes
Grading Ratio	1.5	1.5
MAIA	Y	Y
Surface Detection	VMS + 6p	VMS + 6p
Scan Method	Measured	Measured

Measurement Results

	Area Scan	Zoom Scan
Date	2021-12-10, 17:00	2021-12-10, 17:08
psSAR1g [W/kg]	0.018	0.019
psSAR10g [W/kg]	0.008	0.008
Power Drift [dB]	-0.12	0.21
Power Scaling	Disabled	Disabled
Scaling Factor [dB]		
TSL Correction	No correction	No correction
M2/M1 [%]		92.8
Dist 3dB Peak [mm]		> 15.0

Warning(s) / Error(s)

Details	Area Scan	Zoom Scan
Warning(s)		
Error(s)		

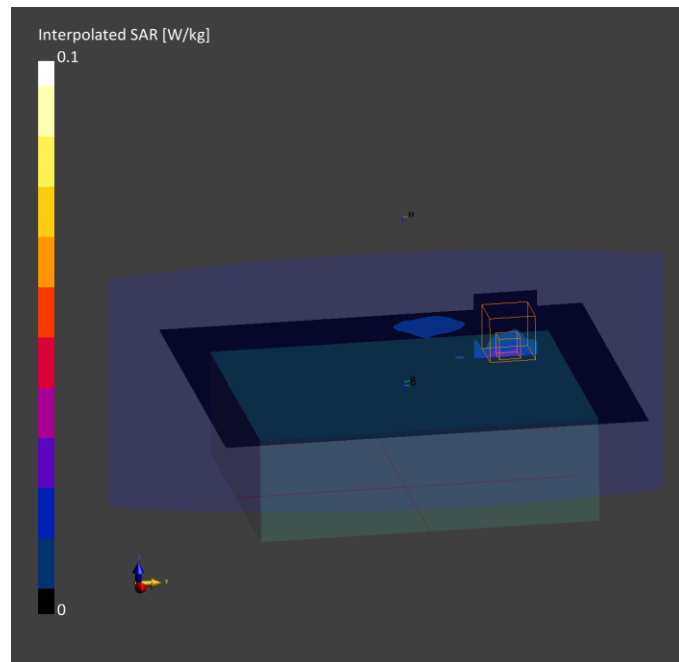

Plot N° 34

Measurement Report for Harman wave, BACK, Band n66, UID 10934 AAB, Channel 349000 (1745.0MHz)

Device under Test Properties

Model, Manufacturer	Dimensions [mm]	IMEI	DUT Type
Harman wave,	160.0 x 135.0 x 50.0	350117360052896	TCU

Exposure Conditions

Phantom Section, TSL	Position, Test Distance [mm]	Band	Group, UID	Frequency [MHz], Channel Number	Conversion Factor	TSL Conductivity [S/m]	TSL Permittivity
Flat, HSL	BACK, 10.00	Band n66	5G NR FR1 FDD, 10934-AAB	1745.0, 349000	5.28	1.38	38.9

Hardware Setup

Phantom	TSL, Measured Date	Probe, Calibration Date	DAE, Calibration Date
ELI V4.0 (20deg probe tilt) - 1060	HBBL1350-1850V3-1700MHz-2021-11-30 , --	ES3DV3 - SN3052, 2021-09-22	DAE4 Sn1690, 2021-09-08

Scan Setup

	Area Scan	Zoom Scan
Grid Extents [mm]	180.0 x 210.0	30.0 x 30.0 x 30.0
Grid Steps [mm]	15.0 x 15.0	6.0 x 6.0 x 1.5
Sensor Surface [mm]	3.0	3.0
Graded Grid	Yes	Yes
Grading Ratio	1.5	1.5
MAIA	Y	Y
Surface Detection	VMS + 6p	VMS + 6p
Scan Method	Measured	Measured

Measurement Results

	Area Scan	Zoom Scan
Date	2021-12-01, 18:43	2021-12-01, 18:52
psSAR1g [W/kg]	0.035	0.036
psSAR10g [W/kg]	0.022	0.022
Power Drift [dB]	0.14	-0.27
Power Scaling	Disabled	Disabled
Scaling Factor [dB]		
TSL Correction	No correction	No correction
M2/M1 [%]		87.3
Dist 3dB Peak [mm]		> 15.0

Warning(s) / Error(s)

Details	Area Scan	Zoom Scan
Warning(s)		
Error(s)		

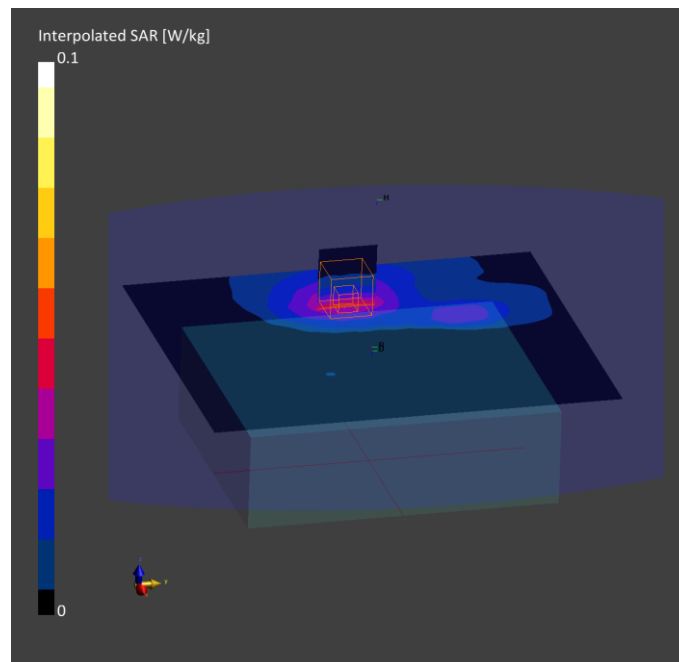

Plot Nº 35

Measurement Report for Harman wave, BACK, Band n71, UID 10931 AAB, Channel 136100 (680.5MHz)

Device under Test Properties

Model, Manufacturer	Dimensions [mm]	IMEI	DUT Type
Harman wave,	160.0 x 135.0 x 50.0	350117360051443	TCU

Exposure Conditions

Phantom Section, TSL	Position, Test Distance [mm]	Band	Group, UID	Frequency [MHz], Channel Number	Conversion Factor	TSL Conductivity [S/m]	TSL Permittivity
Flat, HSL	BACK, 10.00	Band n71	5G NR FR1 FDD, 10931-AAB	680.5, 136100	9.84	0.860	42.8

Hardware Setup

Phantom	TSL, Measured Date	Probe, Calibration Date	DAE, Calibration Date
ELI V4.0 (20deg probe tilt) - 1060	HSL750V2-2021-12-14 , --	EX3DV4 - SN7461, 2020-08-28	DAE4 Sn669, 2021-09-13

Scan Setup

	Area Scan	Zoom Scan
Grid Extents [mm]	180.0 x 210.0	30.0 x 30.0 x 30.0
Grid Steps [mm]	15.0 x 15.0	6.0 x 6.0 x 1.5
Sensor Surface [mm]	3.0	1.4
Graded Grid	Yes	Yes
Grading Ratio	1.5	1.5
MAIA	Y	Y
Surface Detection	VMS + 6p	All points
Scan Method	Measured	Measured

Measurement Results

	Area Scan	Zoom Scan
Date	2021-12-15, 15:37	2021-12-15, 15:51
psSAR1g [W/kg]	0.020	0.018
psSAR10g [W/kg]	0.014	0.014
Power Drift [dB]	0.09	0.36
Power Scaling	Disabled	Disabled
Scaling Factor [dB]		
TSL Correction	No correction	No correction
M2/M1 [%]		86.9
Dist 3dB Peak [mm]		> 15.0

Warning(s) / Error(s)

Details	Area Scan	Zoom Scan
Warning(s)		
Error(s)		

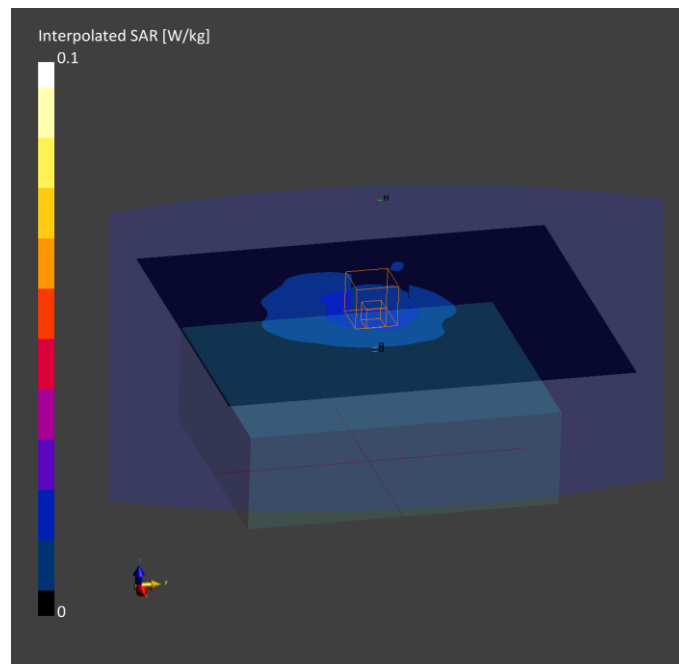

Plot N° 36

Measurement Report for Harman wave, BACK, Band 5, E-UTRA/FDD, UID 10175 CAG, Channel 20450 (829.0MHz)

Device under Test Properties

Model, Manufacturer	Dimensions [mm]	IMEI	DUT Type
Harman wave,	160.0 x 135.0 x 50.0		TCU

Exposure Conditions

Phantom Section, TSL	Position, Test Distance [mm]	Band	Group, UID	Frequency [MHz], Channel Number	Conversion Factor	TSL Conductivity [S/m]	TSL Permittivity
Flat, HSL	BACK, 10.00	Band 5, E-UTRA/FDD	LTE-FDD, 10175-CAG	829.0, 20450	6.12	0.880	41.1

Hardware Setup

Phantom	TSL, Measured Date	Probe, Calibration Date	DAE, Calibration Date
ELI V4.0 (20deg probe tilt) - 1060	HSL900V2 - 2021-10-27 , --	ES3DV3 - SN3052, 2021-09-22	DAE4 Sn1690, 2021-09-08

Scan Setup

	Area Scan	Zoom Scan
Grid Extents [mm]	180.0 x 210.0	30.0 x 30.0 x 30.0
Grid Steps [mm]	15.0 x 15.0	6.0 x 6.0 x 1.5
Sensor Surface [mm]	3.0	3.0
Graded Grid	Yes	Yes
Grading Ratio	1.5	1.5
MAIA	N/A	N/A
Surface Detection	VMS + 6p	All points
Scan Method	Measured	Measured

Measurement Results

	Area Scan	Zoom Scan
Date	2021-10-28, 16:08	2021-10-28, 16:20
psSAR1g [W/kg]	0.137	0.144
psSAR10g [W/kg]	0.095	0.105
Power Drift [dB]	0.06	0.07
Power Scaling	Disabled	Disabled
Scaling Factor [dB]		
TSL Correction	No correction	No correction
M2/M1 [%]		90.5
Dist 3dB Peak [mm]		> 15.0

Warning(s) / Error(s)

Details	Area Scan	Zoom Scan
Warning(s)		
Error(s)		

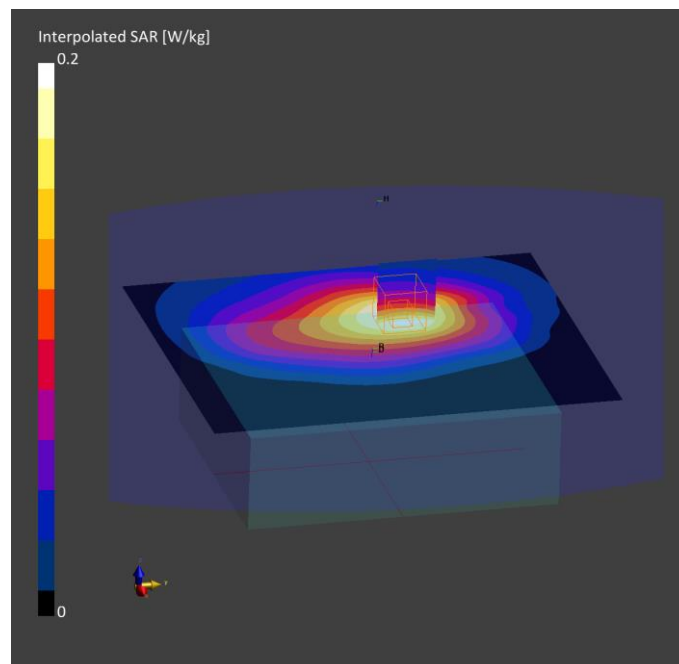

Plot N° 37

Measurement Report for Harman wave, BACK, Band 7, E-UTRA/FDD, UID 10169 CAE, Channel 21100 (2535.0MHz)

Device under Test Properties

Model, Manufacturer	Dimensions [mm]	IMEI	DUT Type
Harman wave,	160.0 x 135.0 x 50.0	350117360052896	TCU

Exposure Conditions

Phantom Section, TSL	Position, Test Distance [mm]	Band	Group, UID	Frequency [MHz], Channel Number	Conversion Factor	TSL Conductivity [S/m]	TSL Permittivity
Flat, HSL	BACK, 10.00	Band 7, E-UTRA/FDD	LTE-FDD, 10169-CAE	2535.0, 21100	7.27	1.90	39.5

Hardware Setup

Phantom	TSL, Measured Date	Probe, Calibration Date	DAE, Calibration Date
ELI V4.0 (20deg probe tilt) - 1060	HBBL1900-3800V3-2300-2600MHz-2021-12-15 , --	EX3DV4 - SN7461, 2020-08-28	DAE4 Sn669, 2021-09-13

Scan Setup

	Area Scan	Zoom Scan
Grid Extents [mm]	180.0 x 200.0	30.0 x 30.0 x 30.0
Grid Steps [mm]	10.0 x 10.0	5.0 x 5.0 x 1.5
Sensor Surface [mm]	3.0	1.4
Graded Grid	Yes	Yes
Grading Ratio	1.5	1.5
MAIA	Y	Y
Surface Detection	VMS + 6p	VMS + 6p
Scan Method	Measured	Measured

Measurement Results

	Area Scan	Zoom Scan
Date	2021-12-17, 14:20	2021-12-17, 14:28
psSAR1g [W/kg]	0.063	0.064
psSAR10g [W/kg]	0.036	0.036
Power Drift [dB]	0.03	-0.12
Power Scaling	Disabled	Disabled
Scaling Factor [dB]		
TSL Correction	No correction	No correction
M2/M1 [%]		82.9
Dist 3dB Peak [mm]		> 15.0

Warning(s) / Error(s)

Details	Area Scan	Zoom Scan
Warning(s)		
Error(s)		

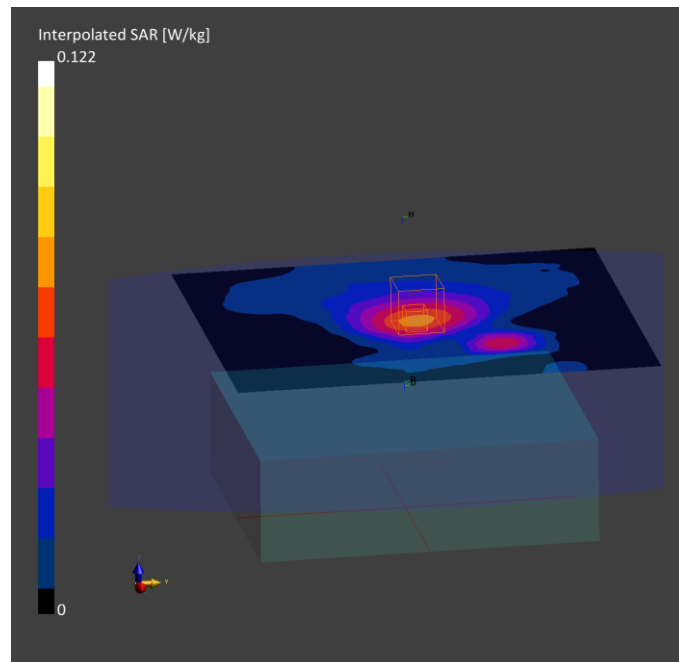

Plot N° 38

Measurement Report for Harman wave, BACK, Band 13, E-UTRA/FDD, UID 10175 CAG, Channel 23230 (782.0MHz)

Device under Test Properties

Model, Manufacturer	Dimensions [mm]	IMEI	DUT Type
Harman wave,	160.0 x 135.0 x 50.0	350117360051443	TCU

Exposure Conditions

Phantom Section, TSL	Position, Test Distance [mm]	Band	Group, UID	Frequency [MHz], Channel Number	Conversion Factor	TSL Conductivity [S/m]	TSL Permittivity
Flat, HSL	BACK, 10.00	Band 13, E-UTRA/FDD	LTE-FDD, 10175-CAG	782.0, 23230	9.84	0.920	41.3

Hardware Setup

Phantom	TSL, Measured Date	Probe, Calibration Date	DAE, Calibration Date
ELI V4.0 (20deg probe tilt) - 1060	HSL750V2-2021-12-14 , --	EX3DV4 - SN7461, 2020-08-28	DAE4 Sn669, 2021-09-13

Scan Setup

	Area Scan	Zoom Scan
Grid Extents [mm]	180.0 x 210.0	30.0 x 30.0 x 30.0
Grid Steps [mm]	15.0 x 15.0	6.0 x 6.0 x 1.5
Sensor Surface [mm]	3.0	1.4
Graded Grid	Yes	Yes
Grading Ratio	1.5	1.5
MAIA	Y	N/A
Surface Detection	VMS + 6p	All points
Scan Method	Measured	Measured

Measurement Results

	Area Scan	Zoom Scan
Date	2021-12-15, 17:10	2021-12-15, 17:23
psSAR1g [W/kg]	0.120	0.122
psSAR10g [W/kg]	0.085	0.091
Power Drift [dB]	0.02	0.11
Power Scaling	Disabled	Disabled
Scaling Factor [dB]		
TSL Correction	No correction	No correction
M2/M1 [%]		88.8
Dist 3dB Peak [mm]		> 15.0

Warning(s) / Error(s)

Details	Area Scan	Zoom Scan
Warning(s)		
Error(s)		

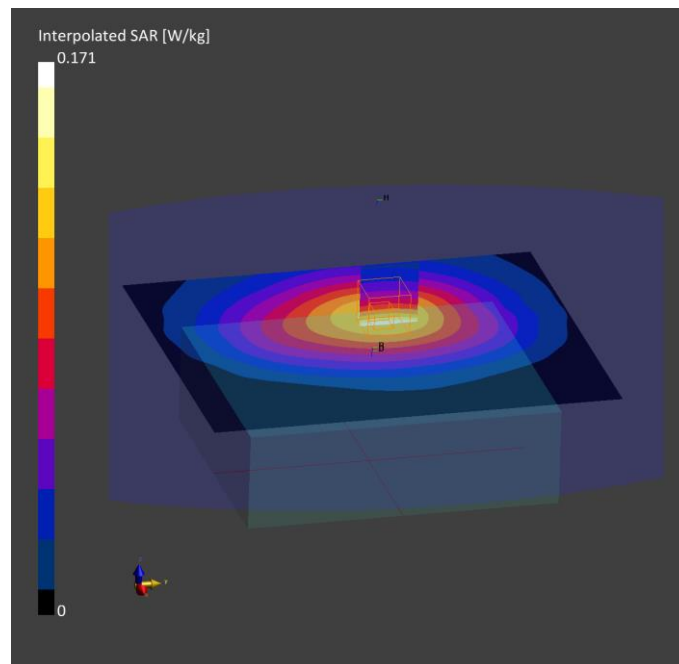

Plot N° 39

Measurement Report for Harman wave, BACK, Band 25, E-UTRA/FDD, UID 10169 CAE, Channel 26140 (1860.0MHz)

Device under Test Properties

Model, Manufacturer	Dimensions [mm]	IMEI	DUT Type
Harman wave,	160.0 x 135.0 x 50.0		TCU

Exposure Conditions

Phantom Section, TSL	Position, Test Distance [mm]	Band	Group, UID	Frequency [MHz], Channel Number	Conversion Factor	TSL Conductivity [S/m]	TSL Permittivity
Flat, HSL	BACK, 10.00	Band 25, E-UTRA/FDD	LTE-FDD, 10169-CAE	1860.0, 26140	5.28	1.39	39.4

Hardware Setup

Phantom	TSL, Measured Date	Probe, Calibration Date	DAE, Calibration Date
ELI V4.0 (20deg probe tilt) - 1060	HBBL1550-1950V3_Head-05-11-2021, --	ES3DV3 - SN3052, 2021-09-22	DAE4 Sn1690, 2021-09-08

Scan Setup

	Area Scan	Zoom Scan
Grid Extents [mm]	180.0 x 210.0	30.0 x 30.0 x 30.0
Grid Steps [mm]	15.0 x 15.0	6.0 x 6.0 x 1.5
Sensor Surface [mm]	3.0	3.0
Graded Grid	Yes	Yes
Grading Ratio	1.5	1.5
MAIA	Y	Y
Surface Detection	VMS + 6p	VMS + 6p
Scan Method	Measured	Measured

Measurement Results

	Area Scan	Zoom Scan
Date	2021-11-05, 16:50	2021-11-05, 16:57
psSAR1g [W/kg]	0.040	0.040
psSAR10g [W/kg]	0.025	0.024
Power Drift [dB]	0.04	-0.05
Power Scaling	Disabled	Disabled
Scaling Factor [dB]		
TSL Correction	No correction	No correction
M2/M1 [%]		86.7
Dist 3dB Peak [mm]		> 15.0

Warning(s) / Error(s)

Details	Area Scan	Zoom Scan
Warning(s)		
Error(s)		

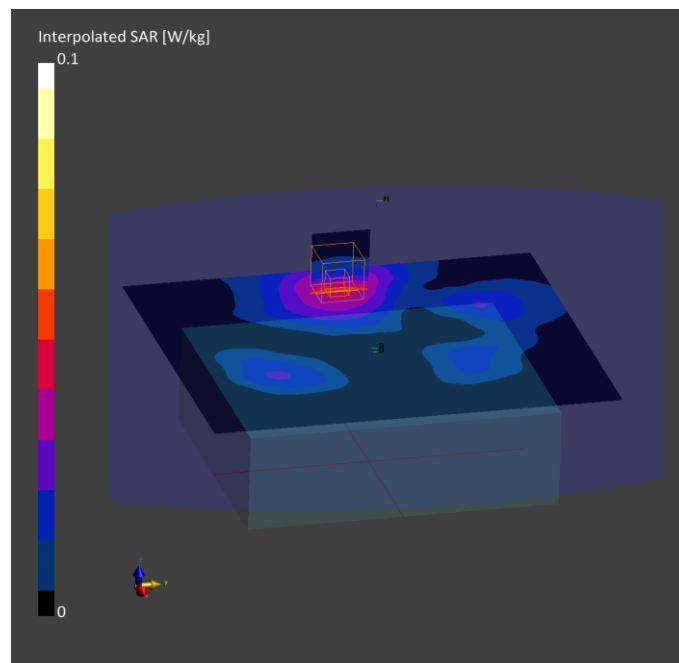

Plot N° 40

Measurement Report for Harman wave, BACK, Band 66, E-UTRA/FDD, UID 10169 CAE, Channel 132572 (1770.0MHz)

Device under Test Properties

Model, Manufacturer	Dimensions [mm]	IMEI	DUT Type
Harman wave,	160.0 x 135.0 x 50.0		TCU

Exposure Conditions

Phantom Section, TSL	Position, Test Distance [mm]	Band	Group, UID	Frequency [MHz], Channel Number	Conversion Factor	TSL Conductivity [S/m]	TSL Permittivity
Flat, HSL	BACK, 10.00	Band 66, E-UTRA/FDD	LTE-FDD, 10169-CAE	1770.0, 132572	5.28	1.43	38.7

Hardware Setup

Phantom	TSL, Measured Date	Probe, Calibration Date	DAE, Calibration Date
ELI V4.0 (20deg probe tilt) - 1060	HBBL1350-1850V3-1700MHz-2021-11-02 , --	ES3DV3 - SN3052, 2021-09-22	DAE4 Sn1690, 2021-09-08

Scan Setup

	Area Scan	Zoom Scan
Grid Extents [mm]	180.0 x 210.0	30.0 x 30.0 x 30.0
Grid Steps [mm]	15.0 x 15.0	6.0 x 6.0 x 1.5
Sensor Surface [mm]	3.0	3.0
Graded Grid	Yes	Yes
Grading Ratio	1.5	1.5
MAIA	Y	Y
Surface Detection	VMS + 6p	VMS + 6p
Scan Method	Measured	Measured

Measurement Results

	Area Scan	Zoom Scan
Date	2021-11-02, 17:14	2021-11-02, 17:20
psSAR1g [W/kg]	0.056	0.055
psSAR10g [W/kg]	0.035	0.034
Power Drift [dB]	-0.08	-0.07
Power Scaling	Disabled	Disabled
Scaling Factor [dB]		
TSL Correction	No correction	No correction
M2/M1 [%]		85.3
Dist 3dB Peak [mm]		> 15.0

Warning(s) / Error(s)

Details	Area Scan	Zoom Scan
Warning(s)		
Error(s)		

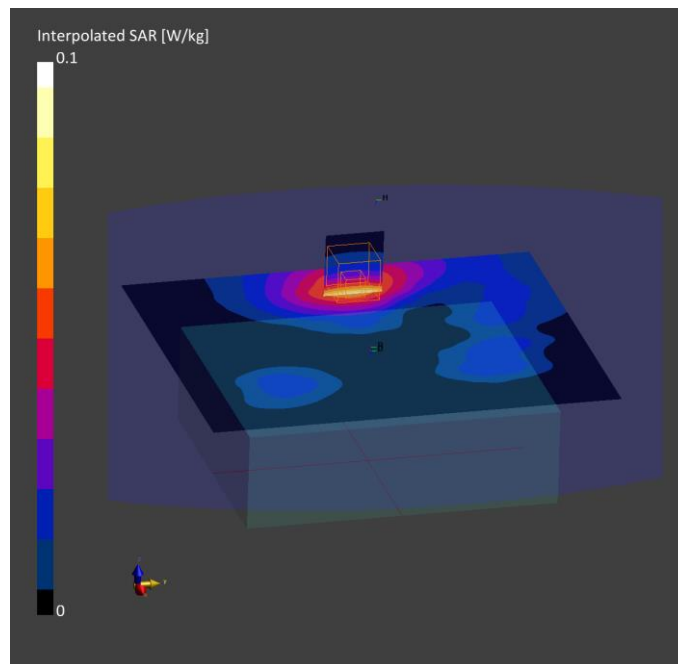

Appendix E: System Validation Reports

Validation results in 750 MHz Band for Head TSL
Measurement Report for Harman wave, , , UID 0 -, Channel 0 (750.0MHz)

Device under Test Properties

Model, Manufacturer	Dimensions [mm]	IMEI	DUT Type
Harman wave,	50.0 x 10.0 x 50.0	350117360052896	Dipole

Exposure Conditions

Phantom Section, TSL	Position, Test Distance [mm]	Band	Group, UID	Frequency [MHz], Channel Number	Conversion Factor	TSL Conductivity [S/m]	TSL Permittivity
Flat, HSL	,		, 0--	750.0, 0	9.84	0.910	41.8

Hardware Setup

Phantom	TSL, Measured Date	Probe, Calibration Date	DAE, Calibration Date
ELI V4.0 (20deg probe tilt) - 1060	HSL750V2-2021-11-24 , --	EX3DV4 - SN7461, 2020-08-28	DAE4 Sn669, 2021-09-13

Scan Setup

	Area Scan	Zoom Scan
Grid Extents [mm]	40.0 x 90.0	30.0 x 30.0 x 30.0
Grid Steps [mm]	10.0 x 15.0	6.0 x 6.0 x 1.5
Sensor Surface [mm]	3.0	1.4
Graded Grid	Yes	Yes
Grading Ratio	1.5	1.5
MAIA	N/A	N/A
Surface Detection	VMS + 6p	VMS + 6p
Scan Method	Measured	Measured

Measurement Results

	Area Scan	Zoom Scan
Date	2021-11-24, 18:16	2021-11-24, 18:21
psSAR1g [W/kg]	2.24	2.16
psSAR10g [W/kg]	1.49	1.41
Power Drift [dB]	0.05	0.04
Power Scaling	Disabled	Disabled
Scaling Factor [dB]		
TSL Correction	No correction	No correction
M2/M1 [%]		86.7
Dist 3dB Peak [mm]		23.8

Warning(s) / Error(s)

Details	Area Scan	Zoom Scan
Warning(s)		
Error(s)		

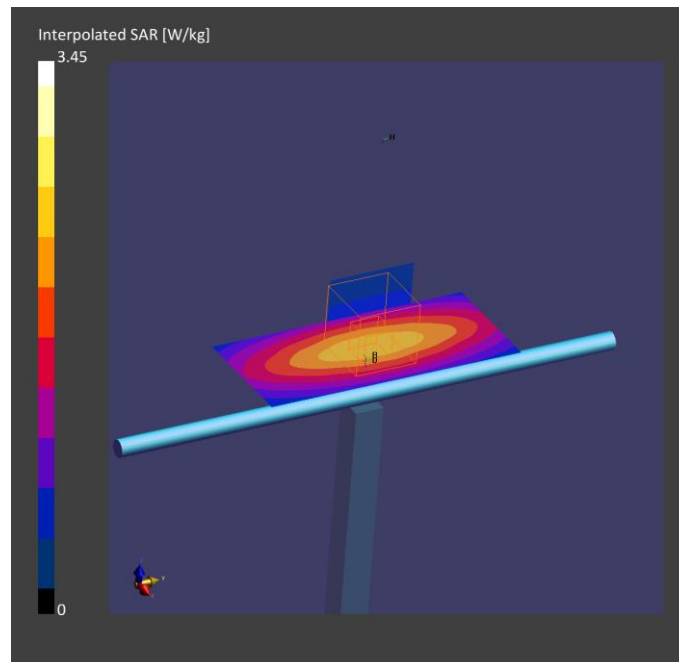

Validation results in 750 MHz Band for Head TSL

Measurement Report for Harman wave, , , UID 0 -, Channel 0 (750.0MHz)

Device under Test Properties

Model, Manufacturer	Dimensions [mm]	IMEI	DUT Type
Harman wave,	50.0 x 10.0 x 50.0	350117360052896	Dipole

Exposure Conditions

Phantom Section, TSL	Position, Test Distance [mm]	Band	Group, UID	Frequency [MHz], Channel Number	Conversion Factor	TSL Conductivity [S/m]	TSL Permittivity
Flat, HSL	,		, 0--	750.0, 0	9.84	0.900	41.8

Hardware Setup

Phantom	TSL, Measured Date	Probe, Calibration Date	DAE, Calibration Date
ELI V4.0 (20deg probe tilt) - 1060	HSL750V2-2021-12-14 , --	EX3DV4 - SN7461, 2020-08-28	DAE4 Sn669, 2021-09-13

Scan Setup

	Area Scan	Zoom Scan
Grid Extents [mm]	40.0 x 90.0	30.0 x 30.0 x 30.0
Grid Steps [mm]	10.0 x 15.0	6.0 x 6.0 x 1.5
Sensor Surface [mm]	3.0	1.4
Graded Grid	Yes	Yes
Grading Ratio	1.5	1.5
MAIA	N/A	N/A
Surface Detection	VMS + 6p	VMS + 6p
Scan Method	Measured	Measured

Measurement Results

	Area Scan	Zoom Scan
Date	2021-12-15, 08:23	2021-12-15, 08:28
psSAR1g [W/kg]	2.18	2.13
psSAR10g [W/kg]	1.45	1.39
Power Drift [dB]	0.02	-0.00
Power Scaling	Disabled	Disabled
Scaling Factor [dB]		
TSL Correction	No correction	No correction
M2/M1 [%]		86.7
Dist 3dB Peak [mm]		> 15.0

Warning(s) / Error(s)

Details	Area Scan	Zoom Scan
Warning(s)		
Error(s)		

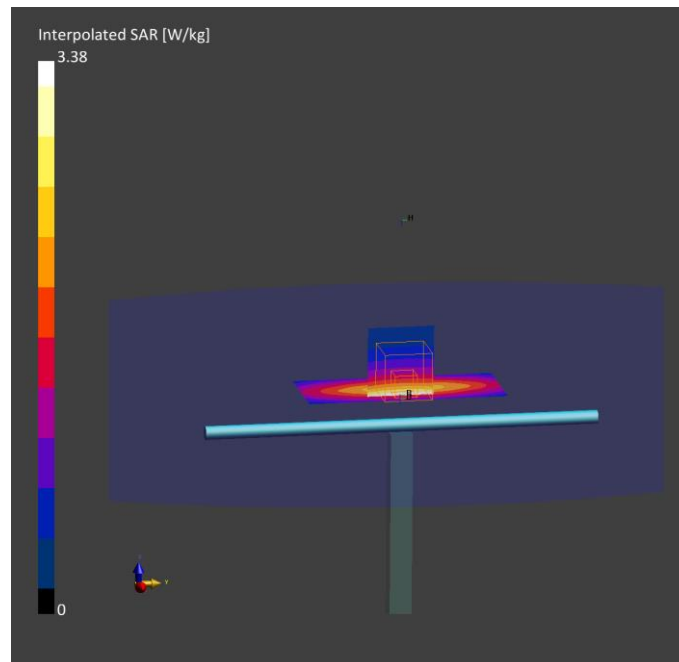

Validation results in 900 MHz Band for Head TSL
Measurement Report for Harman wave, , , UID 0 -, Channel 0 (900.0MHz)

Device under Test Properties

Model, Manufacturer	Dimensions [mm]	IMEI	DUT Type
Harman wave,	50.0 x 10.0 x 50.0		Dipole

Exposure Conditions

Phantom Section, TSL	Position, Test Distance [mm]	Band	Group, UID	Frequency [MHz], Channel Number	Conversion Factor	TSL Conductivity [S/m]	TSL Permittivity
Flat, HSL	,		, 0--	900.0, 0	6.12	0.960	40.2

Hardware Setup

Phantom	TSL, Measured Date	Probe, Calibration Date	DAE, Calibration Date
ELI V4.0 (20deg probe tilt) - 1060	HSL900V2 - 2021-10-27 , --	ES3DV3 - SN3052, 2021-09-22	DAE4 Sn1690, 2021-09-08

Scan Setup

	Area Scan	Zoom Scan
Grid Extents [mm]	40.0 x 90.0	30.0 x 30.0 x 30.0
Grid Steps [mm]	10.0 x 15.0	6.0 x 6.0 x 1.5
Sensor Surface [mm]	3.0	3.0
Graded Grid	Yes	Yes
Grading Ratio	1.5	1.5
MAIA	N/A	N/A
Surface Detection	VMS + 6p	VMS + 6p
Scan Method	Measured	Measured

Measurement Results

	Area Scan	Zoom Scan
Date	2021-10-27, 12:57	2021-10-27, 13:02
psSAR1g [W/kg]	3.00	2.91
psSAR10g [W/kg]	1.95	1.85
Power Drift [dB]	-0.01	0.01
Power Scaling	Disabled	Disabled
Scaling Factor [dB]		
TSL Correction	No correction	No correction
M2/M1 [%]		87.5
Dist 3dB Peak [mm]		22.9

Warning(s) / Error(s)

Details	Area Scan	Zoom Scan
Warning(s)		
Error(s)		

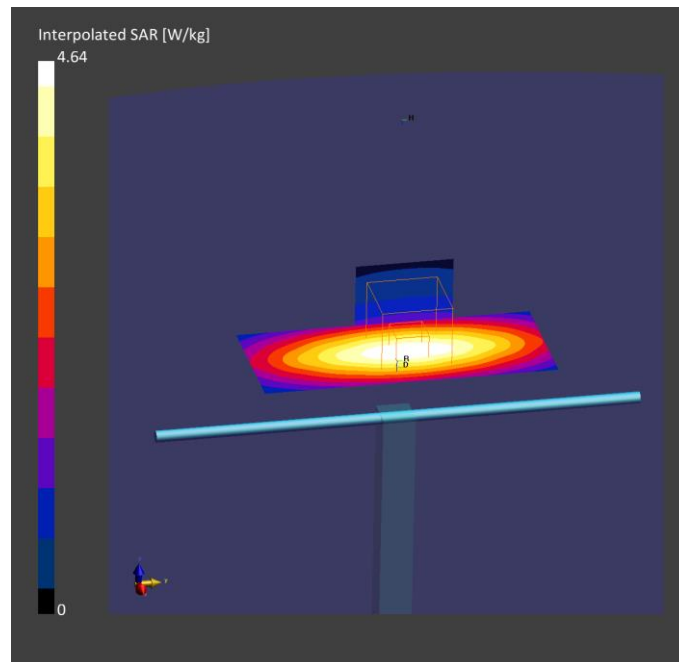

Validation results in 900 MHz Band for Head TSL

Measurement Report for Harman wave, , , UID 0 -, Channel 0 (900.0MHz)

Device under Test Properties

Model, Manufacturer	Dimensions [mm]	IMEI	DUT Type
Harman wave,	50.0 x 10.0 x 50.0		Dipole

Exposure Conditions

Phantom Section, TSL	Position, Test Distance [mm]	Band	Group, UID	Frequency [MHz], Channel Number	Conversion Factor	TSL Conductivity [S/m]	TSL Permittivity
Flat, HSL	,		, 0--	900.0, 0	6.12	0.960	40.7

Hardware Setup

Phantom	TSL, Measured Date	Probe, Calibration Date	DAE, Calibration Date
ELI V4.0 (20deg probe tilt) - 1060	HSL900V2_Head-11-11-2021 , --	ES3DV3 - SN3052, 2021-09-22	DAE4 Sn1690, 2021-09-08

Scan Setup

	Area Scan	Zoom Scan
Grid Extents [mm]	40.0 x 90.0	30.0 x 30.0 x 30.0
Grid Steps [mm]	10.0 x 15.0	6.0 x 6.0 x 1.5
Sensor Surface [mm]	3.0	3.0
Graded Grid	Yes	Yes
Grading Ratio	1.5	1.5
MAIA	N/A	N/A
Surface Detection	VMS + 6p	VMS + 6p
Scan Method	Measured	Measured

Measurement Results

	Area Scan	Zoom Scan
Date	2021-11-11, 09:58	2021-11-11, 10:03
psSAR1g [W/kg]	2.87	2.75
psSAR10g [W/kg]	1.87	1.75
Power Drift [dB]	0.00	-0.05
Power Scaling	Disabled	Disabled
Scaling Factor [dB]		
TSL Correction	No correction	No correction
M2/M1 [%]		87.8
Dist 3dB Peak [mm]		> 15.0

Warning(s) / Error(s)

Details	Area Scan	Zoom Scan
Warning(s)		
Error(s)		

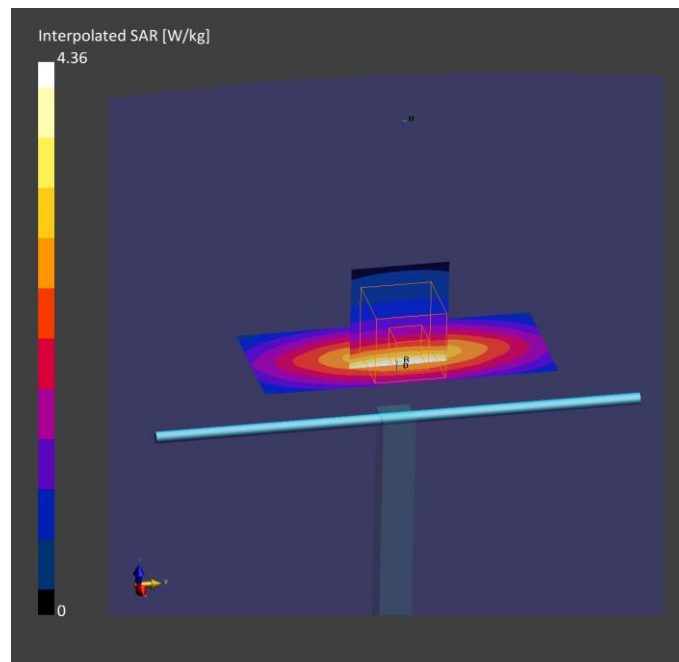

Validation results in 1800 MHz Band for Head TSL

Measurement Report for Harman wave, , , UID 0 -, Channel 0 (1800.0MHz)

Device under Test Properties

Model, Manufacturer	Dimensions [mm]	IMEI	DUT Type
Harman wave,	50.0 x 10.0 x 50.0		Dipole

Exposure Conditions

Phantom Section, TSL	Position, Test Distance [mm]	Band	Group, UID	Frequency [MHz], Channel Number	Conversion Factor	TSL Conductivity [S/m]	TSL Permittivity
Flat, HSL	,		, 0--	1800.0, 0	5.28	1.45	38.5

Hardware Setup

Phantom	TSL, Measured Date	Probe, Calibration Date	DAE, Calibration Date
ELI V4.0 (20deg probe tilt) - 1060	HBBL1350-1850V3-1700MHz-2021-11-02 , --	ES3DV3 - SN3052, 2021-09-22	DAE4 Sn1690, 2021-09-08

Scan Setup

	Area Scan	Zoom Scan
Grid Extents [mm]	40.0 x 90.0	30.0 x 30.0 x 30.0
Grid Steps [mm]	10.0 x 15.0	6.0 x 6.0 x 1.5
Sensor Surface [mm]	3.0	3.0
Graded Grid	Yes	Yes
Grading Ratio	1.5	1.5
MAIA	N/A	N/A
Surface Detection	VMS + 6p	VMS + 6p
Scan Method	Measured	Measured

Measurement Results

	Area Scan	Zoom Scan
Date	2021-11-02, 09:45	2021-11-02, 09:50
psSAR1g [W/kg]	10.5	10.1
psSAR10g [W/kg]	5.55	5.12
Power Drift [dB]	-0.04	0.02
Power Scaling	Disabled	Disabled
Scaling Factor [dB]		
TSL Correction	No correction	No correction
M2/M1 [%]		81.8
Dist 3dB Peak [mm]		10.8

Warning(s) / Error(s)

Details	Area Scan	Zoom Scan
Warning(s)		
Error(s)		

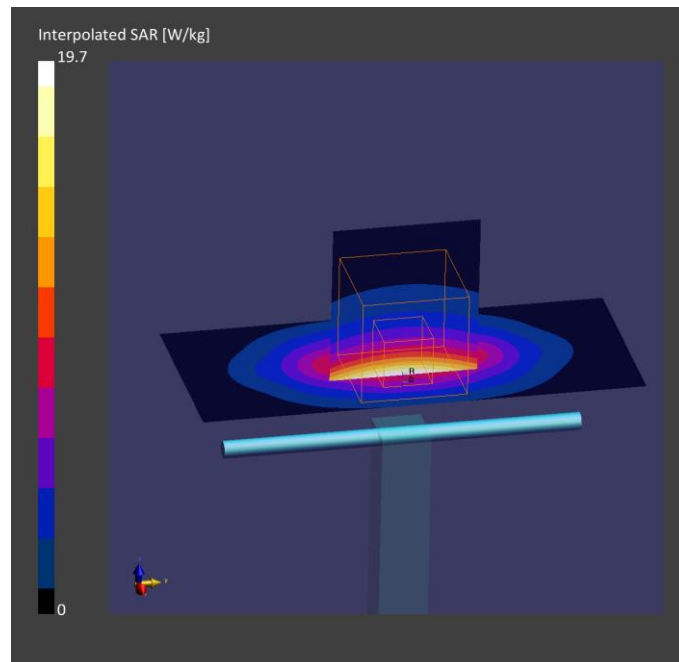

Validation results in 1800 MHz Band for Head TSL

Measurement Report for Harman wave, , , UID 0 -, Channel 0 (1800.0MHz)

Device under Test Properties

Model, Manufacturer	Dimensions [mm]	IMEI	DUT Type
Harman wave,	50.0 x 10.0 x 50.0		Dipole

Exposure Conditions

Phantom Section, TSL	Position, Test Distance [mm]	Band	Group, UID	Frequency [MHz], Channel Number	Conversion Factor	TSL Conductivity [S/m]	TSL Permittivity
Flat, HSL	,		, 0--	1800.0, 0	5.28	1.34	39.5

Hardware Setup

Phantom	TSL, Measured Date	Probe, Calibration Date	DAE, Calibration Date
ELI V4.0 (20deg probe tilt) - 1060	HBBL1550-1950V3_Head-03-11-2021, --	ES3DV3 - SN3052, 2021-09-22	DAE4 Sn1690, 2021-09-08

Scan Setup

	Area Scan	Zoom Scan
Grid Extents [mm]	40.0 x 90.0	30.0 x 30.0 x 30.0
Grid Steps [mm]	10.0 x 15.0	6.0 x 6.0 x 1.5
Sensor Surface [mm]	3.0	3.0
Graded Grid	Yes	Yes
Grading Ratio	1.5	1.5
MAIA	N/A	N/A
Surface Detection	VMS + 6p	VMS + 6p
Scan Method	Measured	Measured

Measurement Results

	Area Scan	Zoom Scan
Date	2021-11-03, 16:46	2021-11-03, 16:52
psSAR1g [W/kg]	9.41	9.10
psSAR10g [W/kg]	4.98	4.74
Power Drift [dB]	-0.00	-0.01
Power Scaling	Disabled	Disabled
Scaling Factor [dB]		
TSL Correction	No correction	No correction
M2/M1 [%]		83.7
Dist 3dB Peak [mm]		10.8

Warning(s) / Error(s)

Details	Area Scan	Zoom Scan
Warning(s)		
Error(s)		

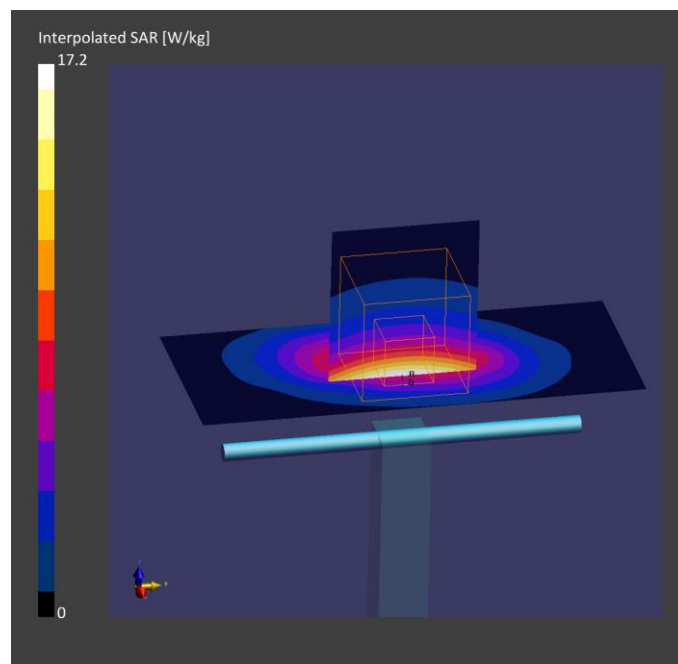

Validation results in 1800 MHz Band for Head TSL

Measurement Report for Harman wave, , , UID 0 -, Channel 0 (1800.0MHz)

Device under Test Properties

Model, Manufacturer	Dimensions [mm]	IMEI	DUT Type
Harman wave,	50.0 x 10.0 x 50.0		Dipole

Exposure Conditions

Phantom Section, TSL	Position, Test Distance [mm]	Band	Group, UID	Frequency [MHz], Channel Number	Conversion Factor	TSL Conductivity [S/m]	TSL Permittivity
Flat, HSL	,		, 0--	1800.0, 0	5.28	1.35	39.5

Hardware Setup

Phantom	TSL, Measured Date	Probe, Calibration Date	DAE, Calibration Date
ELI V4.0 (20deg probe tilt) - 1060	HBBL1550-1950V3_Head-05-11-2021, --	ES3DV3 - SN3052, 2021-09-22	DAE4 Sn1690, 2021-09-08

Scan Setup

	Area Scan	Zoom Scan
Grid Extents [mm]	40.0 x 90.0	30.0 x 30.0 x 30.0
Grid Steps [mm]	10.0 x 15.0	6.0 x 6.0 x 1.5
Sensor Surface [mm]	3.0	3.0
Graded Grid	Yes	Yes
Grading Ratio	1.5	1.5
MAIA	N/A	N/A
Surface Detection	VMS + 6p	VMS + 6p
Scan Method	Measured	Measured

Measurement Results

	Area Scan	Zoom Scan
Date	2021-11-05, 12:28	2021-11-05, 12:33
psSAR1g [W/kg]	9.80	9.50
psSAR10g [W/kg]	5.17	4.91
Power Drift [dB]	0.00	-0.01
Power Scaling	Disabled	Disabled
Scaling Factor [dB]		
TSL Correction	No correction	No correction
M2/M1 [%]		83.6
Dist 3dB Peak [mm]		10.8

Warning(s) / Error(s)

Details	Area Scan	Zoom Scan
Warning(s)		
Error(s)		

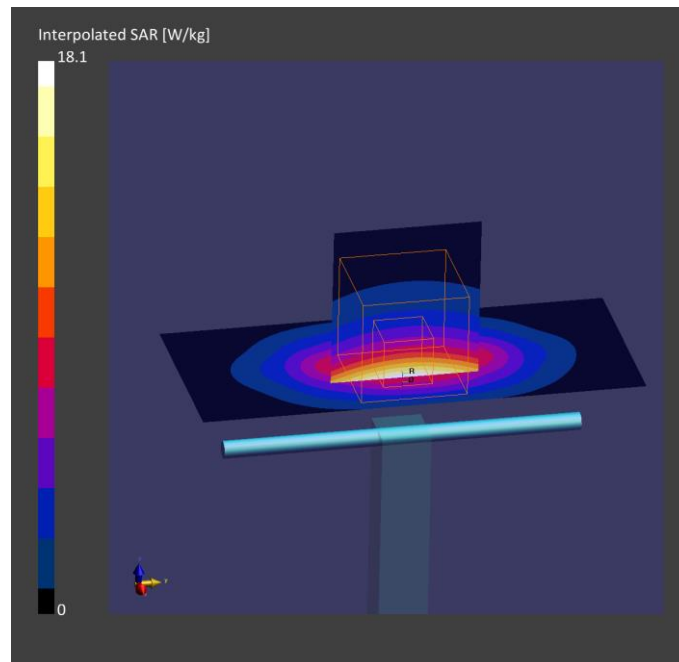

Validation results in 1800 MHz Band for Head TSL

Measurement Report for Harman wave, , , UID 0 -, Channel 0 (1800.0MHz)

Device under Test Properties

Model, Manufacturer	Dimensions [mm]	IMEI	DUT Type
Harman wave,	50.0 x 10.0 x 50.0	350117360052896	Dipole

Exposure Conditions

Phantom Section, TSL	Position, Test Distance [mm]	Band	Group, UID	Frequency [MHz], Channel Number	Conversion Factor	TSL Conductivity [S/m]	TSL Permittivity
Flat, HSL	,		, 0--	1800.0, 0	5.28	1.43	38.5

Hardware Setup

Phantom	TSL, Measured Date	Probe, Calibration Date	DAE, Calibration Date
ELI V4.0 (20deg probe tilt) - 1060	HBBL1350-1850V3-1700MHz-2021-11-30 , --	ES3DV3 - SN3052, 2021-09-22	DAE4 Sn1690, 2021-09-08

Scan Setup

	Area Scan	Zoom Scan
Grid Extents [mm]	40.0 x 90.0	30.0 x 30.0 x 30.0
Grid Steps [mm]	10.0 x 15.0	6.0 x 6.0 x 1.5
Sensor Surface [mm]	3.0	3.0
Graded Grid	Yes	Yes
Grading Ratio	1.5	1.5
MAIA	N/A	N/A
Surface Detection	VMS + 6p	VMS + 6p
Scan Method	Measured	Measured

Measurement Results

	Area Scan	Zoom Scan
Date	2021-11-30, 12:22	2021-11-30, 12:30
psSAR1g [W/kg]	10.1	9.69
psSAR10g [W/kg]	5.35	4.91
Power Drift [dB]	0.02	-0.01
Power Scaling	Disabled	Disabled
Scaling Factor [dB]		
TSL Correction	No correction	No correction
M2/M1 [%]		82.4
Dist 3dB Peak [mm]		10.8

Warning(s) / Error(s)

Details	Area Scan	Zoom Scan
Warning(s)		
Error(s)		

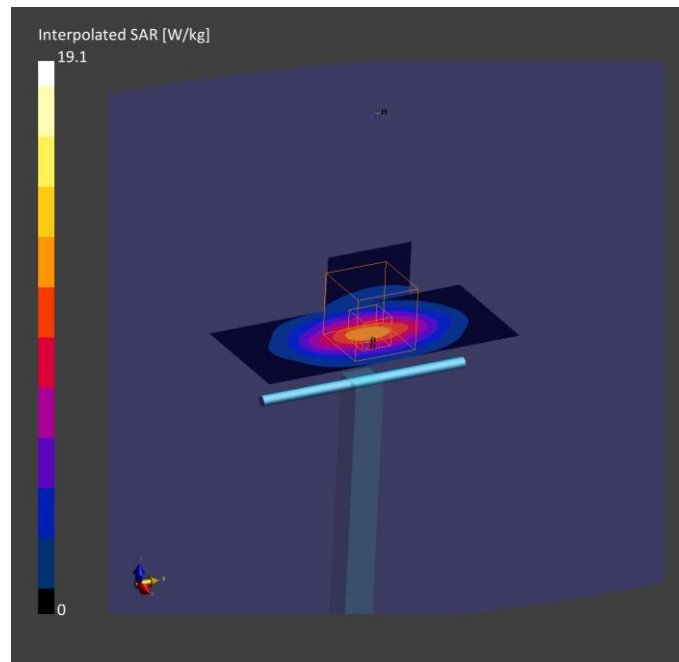

Validation results in 1800 MHz Band for Head TSL

Measurement Report for Harman wave, , , UID 0 -, Channel 0 (1800.0MHz)

Device under Test Properties

Model, Manufacturer	Dimensions [mm]	IMEI	DUT Type
Harman wave,	50.0 x 10.0 x 50.0		Dipole

Exposure Conditions

Phantom Section, TSL	Position, Test Distance [mm]	Band	Group, UID	Frequency [MHz], Channel Number	Conversion Factor	TSL Conductivity [S/m]	TSL Permittivity
Flat, HSL	,		, 0--	1800.0, 0	8.25	1.36	39.6

Hardware Setup

Phantom	TSL, Measured Date	Probe, Calibration Date	DAE, Calibration Date
ELI V4.0 (20deg probe tilt) - 1060	HBBL1550-1950V3_Head-27-12-2021, --	EX3DV4 - SN7461, 2020-08-28	DAE4 Sn669, 2021-09-13

Scan Setup

	Area Scan	Zoom Scan
Grid Extents [mm]	40.0 x 90.0	30.0 x 30.0 x 30.0
Grid Steps [mm]	10.0 x 15.0	6.0 x 6.0 x 1.5
Sensor Surface [mm]	3.0	1.4
Graded Grid	Yes	Yes
Grading Ratio	1.5	1.5
MAIA	N/A	N/A
Surface Detection	VMS + 6p	VMS + 6p
Scan Method	Measured	Measured

Measurement Results

	Area Scan	Zoom Scan
Date	2021-12-27, 09:01	2021-12-27, 09:06
psSAR1g [W/kg]	9.44	9.27
psSAR10g [W/kg]	4.97	4.78
Power Drift [dB]	0.00	0.01
Power Scaling	Disabled	Disabled
Scaling Factor [dB]		
TSL Correction	No correction	No correction
M2/M1 [%]		80.7
Dist 3dB Peak [mm]		10.7

Warning(s) / Error(s)

Details	Area Scan	Zoom Scan
Warning(s)		
Error(s)		

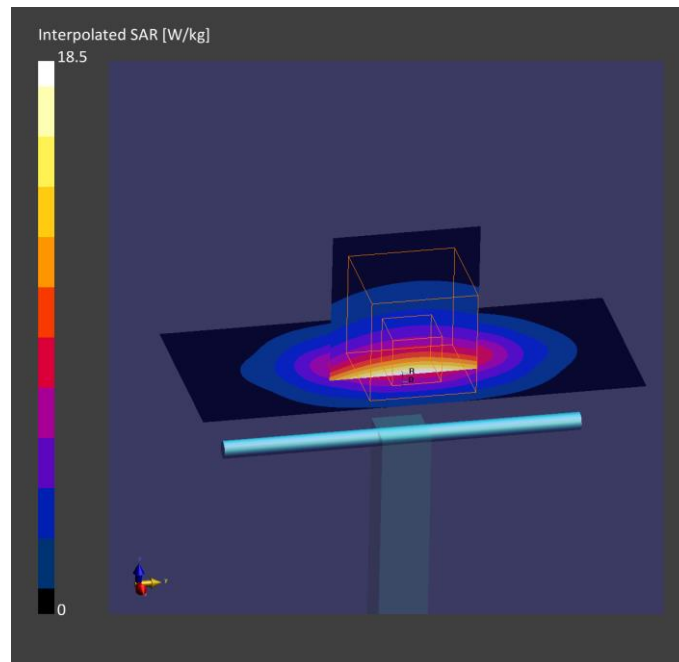

Validation results in 2600 MHz Band for Head TSL

Measurement Report for Harman wave, , , UID 0 -, Channel 0 (2600.0MHz)

Device under Test Properties

Model, Manufacturer	Dimensions [mm]	IMEI	DUT Type
Harman wave,	50.0 x 10.0 x 50.0	350117360052896	Dipole

Exposure Conditions

Phantom Section, TSL	Position, Test Distance [mm]	Band	Group, UID	Frequency [MHz], Channel Number	Conversion Factor	TSL Conductivity [S/m]	TSL Permittivity
Flat, HSL	,		, 0--	2600.0, 0	7.27	2.05	38.6

Hardware Setup

Phantom	TSL, Measured Date	Probe, Calibration Date	DAE, Calibration Date
ELI V4.0 (20deg probe tilt) - 1060	HBBL1900-3800V3-2600MHz-2021-12-09 , --	EX3DV4 - SN7461, 2020-08-28	DAE4 Sn669, 2021-09-13

Scan Setup

	Area Scan	Zoom Scan
Grid Extents [mm]	40.0 x 80.0	30.0 x 30.0 x 30.0
Grid Steps [mm]	10.0 x 10.0	5.0 x 5.0 x 1.5
Sensor Surface [mm]	3.0	1.4
Graded Grid	Yes	Yes
Grading Ratio	1.5	1.5
MAIA	N/A	N/A
Surface Detection	VMS + 6p	VMS + 6p
Scan Method	Measured	Measured

Measurement Results

	Area Scan	Zoom Scan
Date	2021-12-09, 13:13	2021-12-09, 13:20
psSAR1g [W/kg]	15.0	14.4
psSAR10g [W/kg]	6.71	6.21
Power Drift [dB]	0.01	0.04
Power Scaling	Disabled	Disabled
Scaling Factor [dB]		
TSL Correction	No correction	No correction
M2/M1 [%]		77.0
Dist 3dB Peak [mm]		8.9

Warning(s) / Error(s)

Details	Area Scan	Zoom Scan
Warning(s)		
Error(s)		

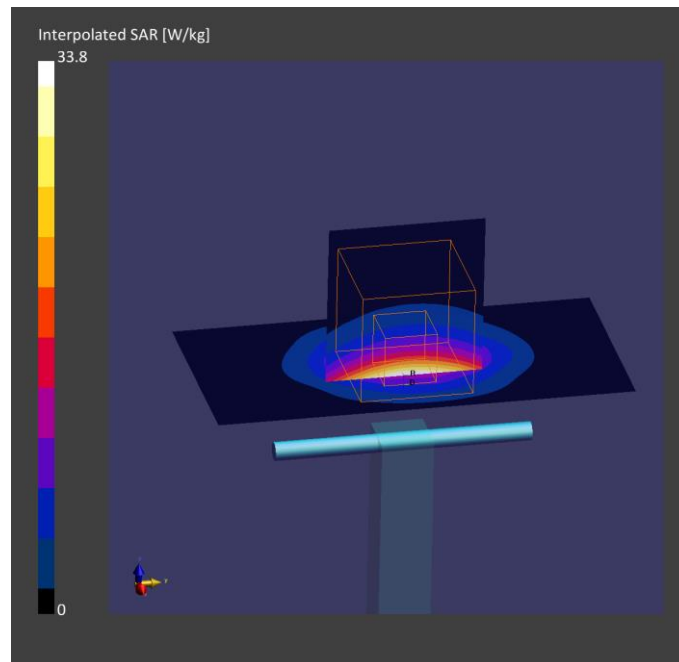

Validation results in 2600 MHz Band for Head TSL

Measurement Report for Harman wave, , , UID 0 -, Channel 0 (2600.0MHz)

Device under Test Properties

Model, Manufacturer	Dimensions [mm]	IMEI	DUT Type
Harman wave,	50.0 x 10.0 x 50.0	350117360052896	Dipole

Exposure Conditions

Phantom Section, TSL	Position, Test Distance [mm]	Band	Group, UID	Frequency [MHz], Channel Number	Conversion Factor	TSL Conductivity [S/m]	TSL Permittivity
Flat, HSL	,		, 0--	2600.0, 0	7.27	1.95	39.4

Hardware Setup

Phantom	TSL, Measured Date	Probe, Calibration Date	DAE, Calibration Date
ELI V4.0 (20deg probe tilt) - 1060	HBBL1900-3800V3-2300-2600MHz-2021-12-15 , --	EX3DV4 - SN7461, 2020-08-28	DAE4 Sn669, 2021-09-13

Scan Setup

	Area Scan	Zoom Scan
Grid Extents [mm]	40.0 x 80.0	30.0 x 30.0 x 30.0
Grid Steps [mm]	10.0 x 10.0	5.0 x 5.0 x 1.5
Sensor Surface [mm]	3.0	1.4
Graded Grid	Yes	Yes
Grading Ratio	1.5	1.5
MAIA	N/A	N/A
Surface Detection	VMS + 6p	VMS + 6p
Scan Method	Measured	Measured

Measurement Results

	Area Scan	Zoom Scan
Date	2021-12-16, 12:34	2021-12-16, 12:40
psSAR1g [W/kg]	14.3	13.8
psSAR10g [W/kg]	6.36	5.98
Power Drift [dB]	0.01	0.02
Power Scaling	Disabled	Disabled
Scaling Factor [dB]		
TSL Correction	No correction	No correction
M2/M1 [%]		77.4
Dist 3dB Peak [mm]		9.0

Warning(s) / Error(s)

Details	Area Scan	Zoom Scan
Warning(s)		
Error(s)		

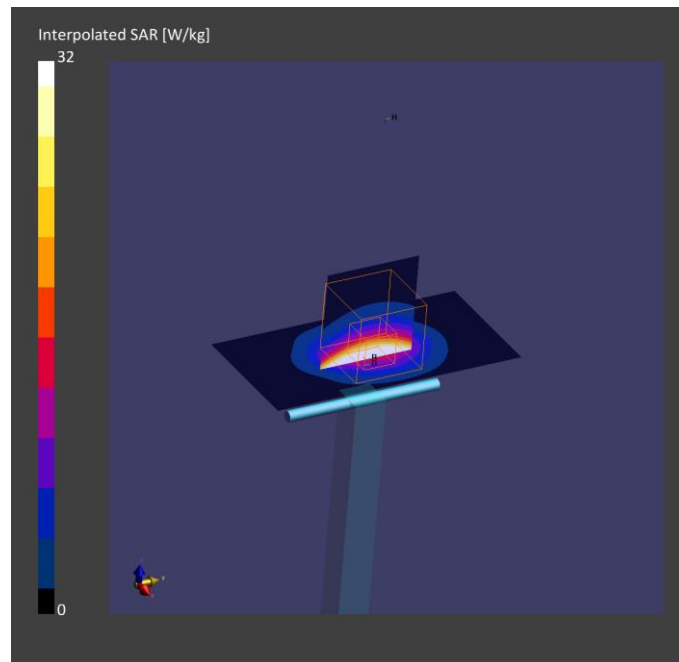

Validation results in 2600 MHz Band for Head TSL

Measurement Report for Harman wave, , , UID 0 -, Channel 0 (2600.0MHz)

Device under Test Properties

Model, Manufacturer	Dimensions [mm]	IMEI	DUT Type
Harman wave,	50.0 x 10.0 x 50.0	350117360052896	Dipole

Exposure Conditions

Phantom Section, TSL	Position, Test Distance [mm]	Band	Group, UID	Frequency [MHz], Channel Number	Conversion Factor	TSL Conductivity [S/m]	TSL Permittivity
Flat, HSL	,		, 0--	2600.0, 0	7.27	2.00	38.6

Hardware Setup

Phantom	TSL, Measured Date	Probe, Calibration Date	DAE, Calibration Date
ELI V4.0 (20deg probe tilt) - 1060	HBBL1900-3800V3-2600MHz-2022-01-03 , --	EX3DV4 - SN7461, 2020-08-28	DAE4 Sn669, 2021-09-13

Scan Setup

	Area Scan	Zoom Scan
Grid Extents [mm]	40.0 x 80.0	30.0 x 30.0 x 30.0
Grid Steps [mm]	10.0 x 10.0	5.0 x 5.0 x 1.5
Sensor Surface [mm]	3.0	1.4
Graded Grid	Yes	Yes
Grading Ratio	1.5	1.5
MAIA	N/A	N/A
Surface Detection	VMS + 6p	VMS + 6p
Scan Method	Measured	Measured

Measurement Results

	Area Scan	Zoom Scan
Date	2022-01-03, 10:32	2022-01-03, 10:38
psSAR1g [W/kg]	14.4	13.9
psSAR10g [W/kg]	6.42	5.92
Power Drift [dB]	0.00	0.00
Power Scaling	Disabled	Disabled
Scaling Factor [dB]		
TSL Correction	No correction	No correction
M2/M1 [%]		76.8
Dist 3dB Peak [mm]		9.0

Warning(s) / Error(s)

Details	Area Scan	Zoom Scan
Warning(s)		
Error(s)		

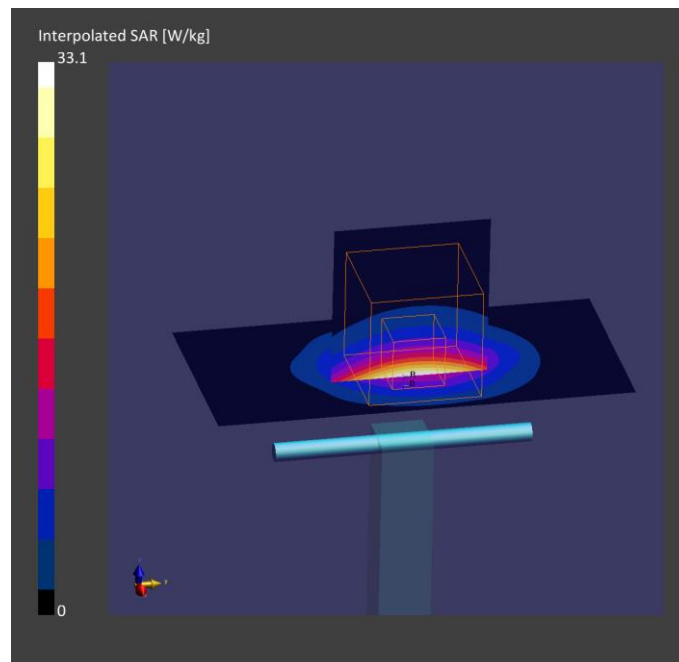

Validation results in 3300 MHz Band for Head TSL

Measurement Report for Harman wave, , , UID 0 -, Channel 0 (3300.0MHz)

Device under Test Properties

Model, Manufacturer	Dimensions [mm]	IMEI	DUT Type
Harman wave,	50.0 x 10.0 x 50.0	350117360051443	Dipole

Exposure Conditions

Phantom Section, TSL	Position, Test Distance [mm]	Band	Group, UID	Frequency [MHz], Channel Number	Conversion Factor	TSL Conductivity [S/m]	TSL Permittivity
Flat, HSL	,		, 0--	3300.0, 0	7.16	2.78	39.1

Hardware Setup

Phantom	TSL, Measured Date	Probe, Calibration Date	DAE, Calibration Date
ELI V4.0 (20deg probe tilt) - 1060	HBBL3500-5800V5-3300-4200MHz-2021-12-20 , --	EX3DV4 - SN7461, 2020-08-28	DAE4 Sn669, 2021-09-13

Scan Setup

	Area Scan	Zoom Scan
Grid Extents [mm]	40.0 x 80.0	28.0 x 28.0 x 28.0
Grid Steps [mm]	10.0 x 10.0	5.0 x 5.0 x 1.4
Sensor Surface [mm]	3.0	1.4
Graded Grid	Yes	Yes
Grading Ratio	1.5	1.5
MAIA	N/A	N/A
Surface Detection	VMS + 6p	VMS + 6p
Scan Method	Measured	Measured

Measurement Results

	Area Scan	Zoom Scan
Date	2021-12-20, 08:15	2021-12-20, 08:22
psSAR1g [W/kg]	6.94	6.74
psSAR10g [W/kg]	2.72	2.63
Power Drift [dB]	-0.01	-0.02
Power Scaling	Disabled	Disabled
Scaling Factor [dB]		
TSL Correction	No correction	No correction
M2/M1 [%]		77.0
Dist 3dB Peak [mm]		8.0

Warning(s) / Error(s)

Details	Area Scan	Zoom Scan
Warning(s)		
Error(s)		

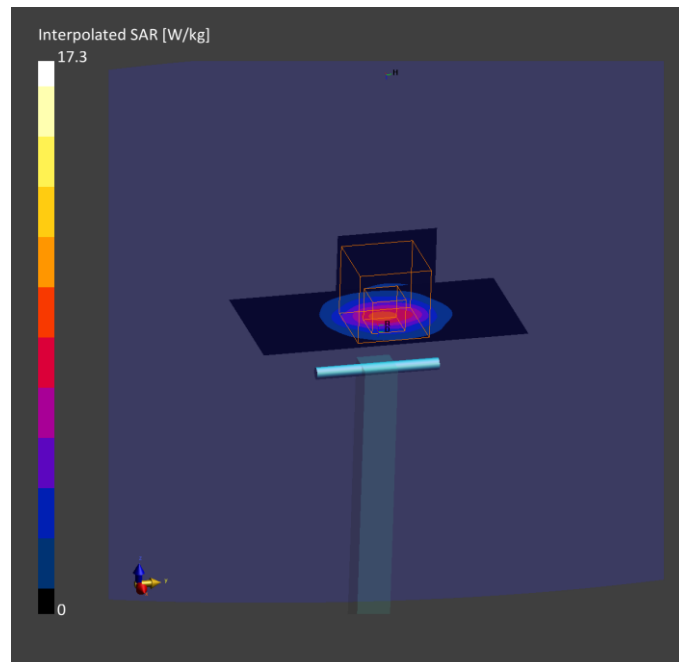

Validation results in 3500 MHz Band for Head TSL

Measurement Report for Harman wave, , , UID 0 -, Channel 0 (3500.0MHz)

Device under Test Properties

Model, Manufacturer	Dimensions [mm]	IMEI	DUT Type
Harman wave,	50.0 x 10.0 x 50.0	350117360052896	Dipole

Exposure Conditions

Phantom Section, TSL	Position, Test Distance [mm]	Band	Group, UID	Frequency [MHz], Channel Number	Conversion Factor	TSL Conductivity [S/m]	TSL Permittivity
Flat, HSL	,	,	0--	3500.0, 0	7.1	2.94	39.2

Hardware Setup

Phantom	TSL, Measured Date	Probe, Calibration Date	DAE, Calibration Date
ELI V4.0 (20deg probe tilt) - 1060	HBBL3500-5800V5-3500MHz-2021-12-22 , --	EX3DV4 - SN7461, 2020-08-28	DAE4 Sn669, 2021-09-13

Scan Setup

	Area Scan	Zoom Scan
Grid Extents [mm]	40.0 x 80.0	28.0 x 28.0 x 28.0
Grid Steps [mm]	10.0 x 10.0	5.0 x 5.0 x 1.4
Sensor Surface [mm]	3.0	1.4
Graded Grid	Yes	Yes
Grading Ratio	1.5	1.5
MAIA	N/A	N/A
Surface Detection	VMS + 6p	VMS + 6p
Scan Method	Measured	Measured

Measurement Results

	Area Scan	Zoom Scan
Date	2021-12-22, 07:50	2021-12-22, 07:57
psSAR1g [W/kg]	6.58	6.59
psSAR10g [W/kg]	2.54	2.45
Power Drift [dB]	-0.04	-0.03
Power Scaling	Disabled	Disabled
Scaling Factor [dB]		
TSL Correction	No correction	No correction
M2/M1 [%]		73.5
Dist 3dB Peak [mm]		8.0

Warning(s) / Error(s)

Details	Area Scan	Zoom Scan
Warning(s)		
Error(s)		

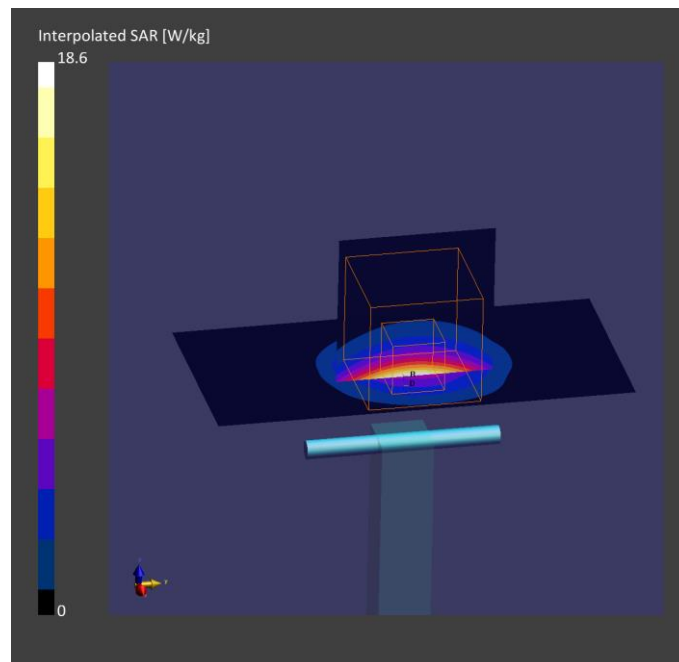

Validation results in 3700 MHz Band for Head TSL

Measurement Report for Harman wave, , , UID 0 -, Channel 0 (3700.0MHz)

Device under Test Properties

Model, Manufacturer	Dimensions [mm]	IMEI	DUT Type
Harman wave,	50.0 x 10.0 x 50.0	350117360051443	Dipole

Exposure Conditions

Phantom Section, TSL	Position, Test Distance [mm]	Band	Group, UID	Frequency [MHz], Channel Number	Conversion Factor	TSL Conductivity [S/m]	TSL Permittivity
Flat, HSL	,	,	0--	3700.0, 0	7.0	3.13	38.6

Hardware Setup

Phantom	TSL, Measured Date	Probe, Calibration Date	DAE, Calibration Date
ELI V4.0 (20deg probe tilt) - 1060	HBBL3500-5800V5-3300-4200MHz-2021-12-20 , --	EX3DV4 - SN7461, 2020-08-28	DAE4 Sn669, 2021-09-13

Scan Setup

	Area Scan	Zoom Scan
Grid Extents [mm]	40.0 x 80.0	28.0 x 28.0 x 28.0
Grid Steps [mm]	10.0 x 10.0	5.0 x 5.0 x 1.4
Sensor Surface [mm]	3.0	1.4
Graded Grid	Yes	Yes
Grading Ratio	1.5	1.5
MAIA	N/A	N/A
Surface Detection	VMS + 6p	VMS + 6p
Scan Method	Measured	Measured

Measurement Results

	Area Scan	Zoom Scan
Date	2021-12-20, 11:46	2021-12-20, 11:52
psSAR1g [W/kg]	7.00	7.00
psSAR10g [W/kg]	2.60	2.58
Power Drift [dB]	0.01	0.00
Power Scaling	Disabled	Disabled
Scaling Factor [dB]		
TSL Correction	No correction	No correction
M2/M1 [%]		72.8
Dist 3dB Peak [mm]		8.5

Warning(s) / Error(s)

Details	Area Scan	Zoom Scan
Warning(s)		
Error(s)		

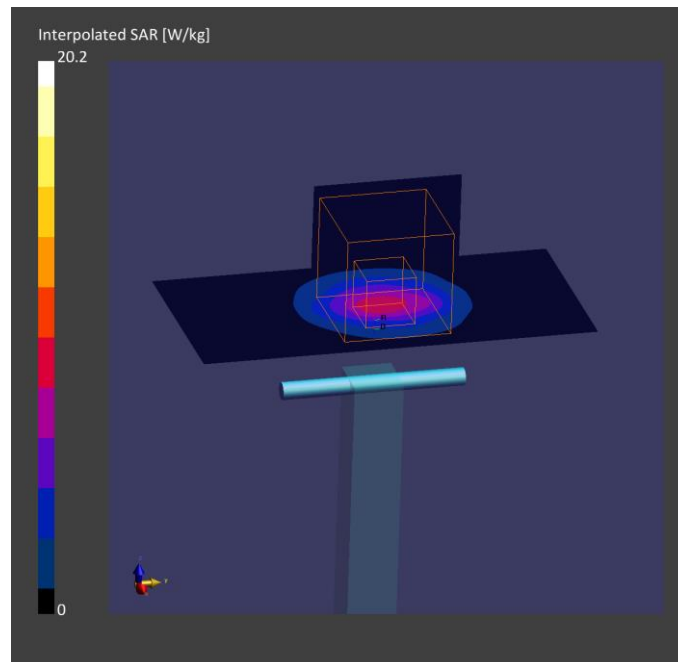

Validation results in 4200 MHz Band for Head TSL

Measurement Report for Harman wave, , , UID 0 -, Channel 0 (4200.0MHz)

Device under Test Properties

Model, Manufacturer	Dimensions [mm]	IMEI	DUT Type
Harman wave,	50.0 x 10.0 x 50.0	350117360051443	Dipole

Exposure Conditions

Phantom Section, TSL	Position, Test Distance [mm]	Band	Group, UID	Frequency [MHz], Channel Number	Conversion Factor	TSL Conductivity [S/m]	TSL Permittivity
Flat, HSL	,		, 0--	4200.0, 0	6.1	3.59	38.0

Hardware Setup

Phantom	TSL, Measured Date	Probe, Calibration Date	DAE, Calibration Date
ELI V4.0 (20deg probe tilt) - 1060	HBBL3500-5800V5-3300-4200MHz-2021-12-20 , --	EX3DV4 - SN7461, 2020-08-28	DAE4 Sn669, 2021-09-13

Scan Setup

	Area Scan	Zoom Scan
Grid Extents [mm]	40.0 x 80.0	25.0 x 25.0 x 25.0
Grid Steps [mm]	10.0 x 10.0	4.0 x 4.0 x 1.4
Sensor Surface [mm]	3.0	1.4
Graded Grid	Yes	Yes
Grading Ratio	1.5	1.4
MAIA	N/A	N/A
Surface Detection	VMS + 6p	VMS + 6p
Scan Method	Measured	Measured

Measurement Results

	Area Scan	Zoom Scan
Date	2021-12-20, 16:13	2021-12-20, 16:22
psSAR1g [W/kg]	6.94	6.95
psSAR10g [W/kg]	2.37	2.38
Power Drift [dB]	-0.01	0.09
Power Scaling	Disabled	Disabled
Scaling Factor [dB]		
TSL Correction	No correction	No correction
M2/M1 [%]		69.3
Dist 3dB Peak [mm]		8.2

Warning(s) / Error(s)

Details	Area Scan	Zoom Scan
Warning(s)		
Error(s)		

