

nations are deleted. Route guidance to the new destination begins.

Add to route: the selected destination address is set as the next intermediate destination. Route guidance begins.

If there are already four intermediate destinations, the multimedia system asks whether intermediate destination 4 should be deleted. Confirm the prompt with **Yes**.

Searching for POIs in the vicinity

 The POI symbols to the right of **POIs in the vicinity** show the first three categories for quick-access. You can configure these categories (→ page 296).

- ▶ Select a POI symbol.
The search results are displayed.
- ▶ Select a POI.
The destination address is shown. The route can be calculated.

or

- ▶ Select **POIs in the vicinity** .

- ▶ Search using categories, enter a search entry or search for a personal POI (→ page 296).
- ▶ Select a POI.
The destination address is shown. The route can be calculated.

Other menu functions

- ▶ **To save the destination:** select  .
- ▶ Select an option.
The following options are available for you:
 - **Save in "Previous destinations"**
 - **Save as favourites**
 - **Save as "My home"**
 - **Save as "Work" address**
- ▶ **To call the destination:** if a telephone number is available, select **Call**.
- ▶ **To share the destination using NFC or QR code:** select **Share via NFC or QR code**.
- ▶ Hold the NFC area of the mobile phone (see manufacturer's operating instructions) on the mat or place the mobile phone on it (→ page 332).

or

- ▶ Hold the mobile phone near to the multimedia system and scan the QR code.
- ▶ **To call up an Internet address:** if a web address is available, select **www**.
- ▶ **To show on the map:** select **Display on map**.

Selecting a route type

Multimedia system:

  **▶▶ Navigation** (Navigation) **▶▶ Route Icon** **▶▶ Route** **▶▶ Route settings**

- ▶ Select the route type.
If no route has been created, the next route is calculated on the basis of the new route type.
If a route has already been created, the route is calculated on the basis of the new route type.
 - **Fast route**
A route with a quick journey time is calculated.
 - **Short route**

A route with a short driving distance is calculated.

- **Eco route**

An economical route is calculated. The journey time may be somewhat longer than for quicker routes.

- **Trailer mode**

Requirement: the option is available if a trailer has been coupled with the vehicle.

A prompt is shown in the multimedia system. Confirm the prompt.

The route is optimised for trailer operation.

The dynamic route can be switched on or off for the route types named.

- **Automatic**

The route is calculated with the currently set route type.

Traffic messages via Live Traffic Information or FM RDS-TMC are taken into account (→ page 313).

Live Traffic Information and FM RDS-TMC are not available in all countries.

- **AFTER ASKING**

A prompt appears when a new route is detected with a shorter journey time based on traffic reports. You can continue to use the current route or use the dynamic route instead (→ page 317).

- **Off**

No traffic reports are taken into account for the route.

The following additional route settings can be activated or deactivated:

- **Suggest alternative route**

If the option is switched on (→ page 304), then an alternative route is calculated for each route.

- **Activate commuter route**

Requirements:

You have created a profile (→ page 265).



The **Learn from location history** option is activated for your profile (→ page 269).

The multimedia system has gathered sufficient data in order to show destination suggestions.

Routes have been learned for these destination suggestions.

If the option is activated (→ page 304), navigation starts route guidance for the learned routes automatically without voice output.

Alternative for calling up route types

▶ Select  ▶ **Navigation** (Navigation) ▶  ▶ **Advanced settings** ▶ **Route settings**.

Selecting route options

Multimedia system:

  ▶ **Navigation** (Navigation) ▶ **Route Icon** ▶ **Route** ▶ **Avoid options**

Avoiding areas

▶ Select **Avoid areas** (→ page 323).

Avoiding motorways, ferries, tunnels, motorail trains, unpaved roads

- ▶ Switch on the avoid option.

Using toll roads

- ▶ Select [Use toll roads](#).
- ▶ Switch the [Payment by cash or card](#) and [Electronic billing](#) options on or off. The route takes into account roads that require the payment of a usage fee (toll) corresponding with the payment type selected.

These route options are not available in every country.

The selected route options cannot always be implemented. Therefore, a route may include a ferry, for instance, even though the avoid [Ferries](#) option is enabled. A message appears and you will hear a corresponding message.



Using routes requiring a special toll sticker

- ▶ Select [Use vignette roads](#).
- ▶ Activate [All](#).

or

- ▶ Switch on the countries that should be taken into account. The route takes into account roads in the selected countries which require you to pay a time-based fee (vignette). A vignette allows for the use of a route network for a limited time period.

Alternative for calling up route options

- ▶ Select  ▶ [Navigation](#) (Navigation) ▶  ▶ [Advanced settings](#) ▶ [Avoid options](#).

Selecting notifications

Multimedia system:

- ▶   ▶ [Navigation](#) (Navigation) ▶  ▶ [Advanced settings](#)

- ▶ Switch an announcement on or off.
 - [Announce street names](#)
The multimedia system announces the names of the roads that will follow the upcoming change of direction. This function is not available in all countries and languages.
 - [Announce traffic warnings](#)

Showing destination information for the route

Requirements:

- A destination is entered.

Multimedia system:

- ▶   ▶ [Navigation](#) (Navigation) ▶ [Route Icon](#) ▶ [Route](#)

- ▶ Select [Route overview](#).
When route guidance is active, the destination and intermediate destinations are shown, if these have been entered and not yet been passed.
The route can include up to four intermediate destinations.
- ▶ Select a destination or an intermediate destination.
The following information is displayed:
 - Remaining driving distance
 - Time of arrival
 - Remaining journey time
 - Name, destination address

- Phone number (if available)
- Web address (if available)

Planning routes

Multimedia system:

  [»» Navigation](#) (Navigation) [»» Route Icon](#) [»» Route overview](#)

- ▶ Select [Set intermediate destination](#).
 - ▶ Enter the intermediate destination as a POI or address, for example (→ page 293).
 - ▶ Select the intermediate destination. After selection of an intermediate destination, the route overview is shown again.
 - ▶ Calculating the route with intermediate destinations (→ page 303)
-  If there are already four intermediate destinations, delete an intermediate destination (→ page 303).

Editing a route with intermediate destinations

Multimedia system:

  [»» Navigation](#) (Navigation) [»» Route Icon](#) [»» Route overview](#)

▶ To change the sequence of destinations:

select  for a destination.

A menu opens.

▶ Select [Move](#).

 is highlighted.

▶ Move the intermediate destination or the destination with or to the desired position.

▶ Tap on .

▶ To delete a destination: select for an intermediate destination or destination.

▶ Select [Delete](#).

The destination is deleted.

Calculating a route with intermediate destinations

Requirements:

- The destination and at least one intermediate destination have been entered.

Multimedia system:

  [»» Navigation](#) (Navigation) [»» Route Icon](#) [»» Route overview](#)

▶ Select [Start route guidance](#).



or

▶ If the route has been edited, select [To Navigation](#).

▶ Confirm the prompt with [Yes](#). The route is calculated. Route guidance begins.

Displaying the route list

Multimedia system:

  **Navigation** (Navigation) **Route Icon** **Route**

- ▶ Select **Route list**.

The list shows the route sections. The current vehicle position is marked on the map.

The current vehicle position is shown with the following information:

- The symbol for the current vehicle position is displayed.
- The name of the road on which you are currently driving is shown.
- The road number of the road on which you are currently driving is shown.

The route list is updated during the journey.

- ▶ **To show route sections:** swipe up or down on the control element.

The route section is shown on the map.

Selecting an alternative route

Multimedia system:

  **Navigation** (Navigation) **Route Icon**

- ▶ Select **Alternative route**.

The routes are displayed in accordance with the setting made in the route settings.

The routes are numbered.

- ▶ Select the alternative route.

Activating a commuter route

Requirements:

- The **Learn from location history** option is activated for your profile (→ page 269).
- The multimedia system has gathered sufficient data in order to show destination suggestions.
- Routes have been learned for these destination suggestions.

Multimedia system:

  **Navigation** (Navigation) **Route Icon** **Route** **Route settings**

- ▶ Activate **Activate commuter route**.

The navigation system automatically detects that the vehicle is on a commuter route. It automatically starts a route guidance without voice output.

For the daily commuter route, traffic incidents on the route are also reported when driving without active route guidance.

Switching the automatic filling station search on/off

Multimedia system:

  **Settings** **Fahrzeug** (Vehicle)

- ▶ Switch **Reserve fuel level** on or off.

When the fuel reserve level is reached, and the option is switched on, a prompt appears asking whether you want to start searching for filling stations.

Starting an automatic filling station search

Requirements:

- The automatic filling station search is activated (→ page 304).

Driving situation

The fuel level in the fuel tank reaches the reserve fuel level.

The [Fuel tank reserve level Do you want to start the search for filling stations?](#) message is shown.

- ▶ Select [Yes](#).
The automatic filling station search begins. The available filling stations along the route or in the vicinity of the vehicle's current position are displayed.
- ▶ Select a filling station.
The address of the filling station is displayed.
- ▶ Calculate the route (→ page 299).
The filling station is set as the destination or the next intermediate destination.

- ▶ **If there are already four intermediate destinations:** select [Yes](#) in the prompt. The filling station is entered in the route overview. Intermediate destination 4 is deleted. Route guidance begins.

Starting the automatic service station search

Requirements:

- ATTENTION ASSIST and the [Suggest rest area](#) function are activated (→ page 213).
- There are service stations along the route section ahead.

Driving situation

The [Suggest rest area. Do you want to start the rest area search?](#) message is shown.

- ▶ Select [Yes](#).
The service station search starts. The available service stations along the route or in the vicinity of the vehicle's current position are displayed.
- ▶ Select a service station.
The service station address is displayed.





- ▶ Calculate the route (→ page 299).
The service station is set as the destination or the next intermediate destination.
- ▶ **If there are already four intermediate destinations:** select [Yes](#) in the prompt. The service station is entered in the route overview. Intermediate destination 4 is deleted. Route guidance begins.

Showing a stored route on the map

Requirements:

- A USB device with stored routes is connected with the multimedia system (→ page 365).
- The route is stored in the "Routes" folder with the GPS Exchange format (.gpx).

Multimedia system:

  [Navigation](#) (Navigation)  [Where to?](#)  [Stored routes](#)



- ▶ Select a route.
- ▶ Select [Display on map](#).
- ▶ Move the map (→ page 320).

Starting a saved route



Requirements:

- A USB device with stored routes is connected with the multimedia system (→ page 365).
- The route is stored in the "Routes" folder with the GPS Exchange format (.gpx).

Multimedia system:

  **Navigation** (Navigation) **Where to?** **Stored routes**

- ▶ Select a route.
 - ▶ Select **Start route guidance from the beginning** or **Start route guidance from current location**.
- Route guidance starts.



 The route can be saved with  in the menu (→ page 299).

Recording a route

Requirements:

- A USB device is connected with the multimedia system (→ page 365).

Multimedia system:

  **Navigation** (Navigation) **Where to?** **Stored routes**



- ▶ **To start recording:** select **Start to record new route**.
A red recording symbol is shown.
The route is stored on the USB device.
- ▶ **To stop recording:** select **End recording**.

Saving a recorded route

Requirements:

- A USB device is connected with the multimedia system (→ page 365).

Multimedia system:

  **Navigation** (Navigation) **Where to?** **Stored routes**



- ▶ Select a route.
- ▶ Select .
- ▶ Select **Store in "Previous destinations"**.
The route is stored in the "Previous destinations" memory and can be called up from there for route guidance.



Editing a stored route

Requirements:

- A USB device with stored routes is connected with the multimedia system (→ page 365).

Multimedia system:

  **Navigation** (Navigation) **Where to?** **Stored routes**

- ▶ Select a route with .
 - ▶ **To enter a name:** select **Change name**.
 - ▶ Enter the name.
 - ▶ Select **OK**.
- or
- ▶ When the name has been changed, press the  button.
 - ▶ Select **Yes**.
 - ▶ **To delete a route:** select **Delete**.
 - ▶ Select **Yes**.

Route guidance

Notes on route guidance

⚠ WARNING Risk of distraction from operating integrated communication equipment while the vehicle is in motion

If you operate communication equipment integrated in the vehicle when driving, you will be distracted from the traffic situation. This could also cause you to lose control of the vehicle.

- ▶ Only operate this equipment when the traffic situation permits.
- ▶ If you cannot be sure of this, stop the vehicle whilst paying attention to road and traffic conditions and operate the equipment with the vehicle stationary.

Route guidance begins once a route has been calculated.

The road and traffic rules and regulations always have priority over multimedia system driving recommendations.

Driving recommendations are:

- Navigation announcements
- Route guidance displays
- Lane recommendations

If you do not follow the navigation announcements or if you leave the calculated route, a new route is calculated automatically.

Driving recommendations may differ from the actual road and traffic conditions if:

- The route is diverted
- The direction of a one-way street has been changed

For this reason, you must always observe road and traffic rules and regulations during your journey.

The route may differ from the ideal route due to the following:

- Roadworks
- Incomplete digital map data

Changing direction overview

Changes of direction are shown in the following displays:

- Detailed image of the junction
The display appears when you drive into a junction.
- 3D image
The display appears when driving on junction-free, multi-lane roads, for example on motorway exits and motorway interchanges.

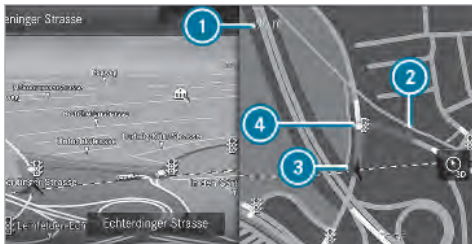

Example: detailed image of the crossing with upcoming changes of direction

- ① Current distance to the change of direction
- ② Changing direction
- ③ Current vehicle position
- ④ Manoeuvre point



Example: 3D image of the upcoming change of direction

- ① Current distance to the change of direction
- ② Changing direction
- ③ Current vehicle position
- ④ Manoeuvre point

There are three phases when changing direction:

- Preparation phase
If there is enough time between the changes of direction, the multimedia system prepares you for the upcoming change of direction. A navigation announcement, e.g. "Prepare to turn right", is issued.

The map appears in full-screen mode.

The status line shows: the direction information or the name of the road which is to be turned into and the distance to the change of direction.

- Announcement phase
The multimedia system announces the upcoming change of direction, e.g. by announcing "Turn right in 100 m".

The display is split into two parts. The map is displayed on the left; on the right, there is a detailed image of the junction or a 3D image of the upcoming change of direction.

- Change-of-direction phase
The multimedia system announces the imminent change of direction, e.g. by announcing "Now turn right".

The display is split into two parts.

The change of direction takes place when the distance to manoeuvre point ④ is shown with 0 m and the symbol for vehicle position ③ has reached manoeuvre point ④.

When the change of direction is complete, the map appears in full-screen mode.

- Changes of direction are also shown in the Instrument Display.

Lane recommendations overview

This display appears for multi-lane roads.

The multimedia system can show lane recommendations if the digital map contains the relevant data.

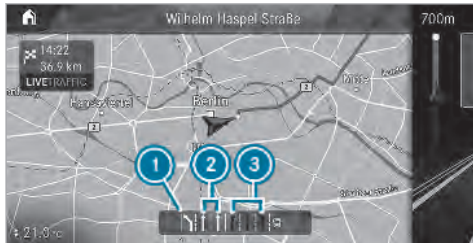

- 1 Recommended lane (white arrow, blue background)
- 2 Possible lanes (white arrow)
- 3 Lanes not recommended (grey arrow)

- Recommended lane 1
In this lane, you will be able to complete both the next change of direction and the one after that.
- Possible lane 2
In this lane, you will only be able to complete the next change of direction.
- Lane not recommended 3
In this lane, you will not be able to complete the next change of direction without changing lane.

During the change of direction, new lanes may be added.

- Bus lanes are also shown.
Lane recommendations can also be displayed in the Instrument Display and in the Head-up Display.

Using motorway information

Requirements:

- The **Motorway information** option is switched on (→ page 322).



When driving on the motorway, upcoming motorway facilities 1 and available service facilities 2 are shown in the overview. These include filling stations, car parks, service stations and motorway exits, for example.

- To open the display:** select .
- The entries are sorted according to increasing distance from the current vehicle position.
- Select an entry.
- Select a service facility from the list.
The details are displayed. The map shows the position and the driving time to this location.

The following functions can be used in the detailed display, for example:

- Search for a POI in the vicinity.
- Save the destination.
- Place a call at the destination.

▶ Calculate the route (→ page 299).

Destination reached

Once the destination is reached, you will see the  chequered flag. Route guidance is finished.

When an intermediate destination has been reached, you will see the intermediate destination flag with the number of your  intermediate destination. After this, route guidance is continued.

Switching navigation announcements on/off

▶ **To switch off:** turn the volume control on the steering wheel or next to the touchpad during a navigation announcement (→ page 275).

The **Spoken driving recommendations have been deactivated.** message appears.

or

▶ Show the navigation menu (→ page 292).

▶ Select .

The symbol changes to .

▶ **To activate:** select .

The current navigation announcement is played.

The symbol changes to .

 This function can be added and called up from the favourites within the navigation category.

Switching navigation announcements on/off during a phone call

▶ Press the  button on the steering wheel or on the touchpad.

or

▶ Briefly press  in the multimedia system display.

▶ Select **Settings**.

▶ Select **System**.





▶ Select **Audio**.

▶ Select **Navigation and traffic announcements**.

▶ Switch **Driving recommendations during call** on or off.

Adjusting the volume of navigation announcements

Multimedia system:

  **Settings**  **System**  **Audio**  **Navigation and traffic announcements**

▶ Select **Fahrempfehlungslautstärke** (Driving recommendation volume).

▶ Set the volume.

Route guidance is active

▶ Turn the volume control on the steering wheel or next to the touchpad during a navigation announcement.

Switching audio fadeout on/off during navigation announcements

▶ Press the  button on the steering wheel or on the touchpad.

or

▶ Briefly press  in the multimedia system display.

- ▶ Select [Settings](#).
- ▶ Select [System](#).
- ▶ Select [Audio](#).
- ▶ Switch [Audio fadeout](#) on or off.



Repeating navigation announcements

Requirements:

- a route has already been created.
- route guidance is active.

Multimedia system:

↳ [Navigation](#) (Navigation)

- ▶ Select .
- ▶ Select .

The current navigation announcement is repeated.

- ⓘ This function can be added and called up from the favourites within the navigation category.

Cancelling route guidance

Requirements:

- a route has been created.

- route guidance is active.
- ▶ Show the navigation menu.
- ▶ Select .

Route guidance to an off-road destination

An off-road destination is within the digital map. The map contains no roads that lead to the destination.

You can enter geo-coordinates or off-road destinations on the map. Route guidance guides you for as long as possible with navigation announcements and displays on roads that are known to the multimedia system.

Shortly before you reach the last known position on the map, you will hear the "Please follow the direction arrow" announcement, for example. The display shows a direction arrow and the linear distance to the destination.

Route guidance from an off-road location to a destination

In an off-road position, the current vehicle position is located within the digital map on roads that are not available.

The following displays appear when route guidance begins:

- A message appears that the road is not on the map.
- A direction arrow showing the linear direction to the POI.

When the vehicle is back on a road known to the multimedia system, route guidance continues as normal.

Off-road status during route guidance

Due to roadworks, for example, there may be differences between the data on the digital map and the actual course of the road. In such cases, the multimedia system will temporarily be unable to locate the vehicle's current position on the digital map. The vehicle is off-road.

The following displays appear when the vehicle is off-road:

- A message appears that the road is not on the map.
- A direction arrow showing the linear direction to the POI.

When the vehicle is back on a road known to the multimedia system, route guidance continues as normal.

Destination

Saving the current vehicle position

Multimedia system:

  **»» Navigation** (Navigation) **»» Route Icon** **»» Position**

▶ Select **Store position**.

The current vehicle position is saved to the "Previous destinations" memory.

Editing the previous destinations

Multimedia system:

  **»» Navigation** (Navigation) **»» Where to?** **»» PREV. DESTINATIONS**

The following destinations can be edited:

- Previous destinations and routes
- Destination suggestions

Requirements: the [Learn from location history](#) option is activated for your profile (→ page 269).

The multimedia system has gathered sufficient data in order to show destination suggestions.

- External destinations and routes

▶ **To no longer display a destination suggestion:** select  for a destination suggestion.

▶ Select **Do not suggest**.

Saving the last destination as a favourite

 After saving, the destination can be called up via the favourites (→ page 271).

▶ Select  for a destination.

▶ Select **Save as favourite**.

▶ **To save as a favourite:** select **Save as favourite**.

▶ **To save as "Home" address:** select **Save as "My home"**.

▶ **To save as "Work" address:** select **Save as "My work"**.

Deleting a previous destination

▶ **To delete a destination:** select  for the previous destination.

▶ Select **Delete**.

▶ Select **Yes**.

▶ **To delete all destinations:** select .

▶ Select **Delete all**.

▶ Select **Yes**.

Using external destinations and routes

External destinations and routes can be received from the following sources, for example:

- Mercedes-Benz Apps
- door-to-door navigation

A prompt appears on the multimedia display. Received destinations and routes are saved in the previous destinations.

▶ **A destination has been received:** select **Yes**.

- ▶ Calculate the route.
 - ▶ If route guidance is already active, select [Set as intermediate dest.](#) or [Start new route guidance.](#)
- or
- ▶ If a destination was received with photo information, select [Start route guidance.](#)
 - ▶ Calculate the route.
- or
- ▶ If a destination has been received from an app, select [Details.](#)
 - ▶ Calculate the route.
 - ▶ **A route has been received:** select [Yes.](#)
 - ▶ Select [Start route guidance from the beginning](#) or [Start route guidance from current location.](#)
- Route guidance starts from the selected position.

Route guidance with current traffic reports

Traffic information overview

- ❗ The services are not available in every country.

Traffic reports can be received with the following services:

- Live Traffic Information
- FM RDS-TMC

It is not possible to use both services simultaneously.

Live Traffic Information or FM RDS-TMC is displayed with a symbol.

- ❗ Hazard warnings can be received using the Car-to-X service.
- ❗ There may be differences between the traffic reports received and the actual road and traffic conditions.

Important information on Live Traffic Information:

- Current traffic reports are received via the Internet connection (for selected countries).

- The traffic situation is updated at short, regular intervals.
- In selected countries, the subscription service is available free of charge for a period of three years from the manufacturing date. Subscription information shows the status (→ page 314).

Registering Live Traffic Information

- The service must be registered with Mercedes me (→ page 314):
This secures the free-of-charge period of three years.

Information on the vehicle's position is regularly sent to Daimler AG. The data is immediately rendered anonymous by Daimler AG and forwarded to the traffic data provider. Using this data, traffic reports relevant to the vehicle's position are sent to the vehicle. The vehicle acts as a sensor for the flow of traffic and helps to improve the quality of the traffic reports.

If you do not want to transmit the vehicle position, you have the following options:

- You deactivate the service in the Mercedes me portal.
- You have the service deactivated at a Mercedes-Benz service centre.

Useful information on FM RDS-TMC:

- A FM RDS-TMC radio station broadcasts traffic reports alongside the radio programme.
- FM RDS-TMC is not available in all countries.

Displaying subscription information

Requirements:

- The vehicle is equipped with Live Traffic Information.

Multimedia system:

  **Navigation**  **Route**
Icon  **Traffic**

 **To display manually:** select [Live Traffic Subscription Info](#).

Depending on the status, one of the following messages appears:

- the traffic data supplier's logo and the validity of the subscription are displayed.
- the logo of the traffic data provider is shown. The subscription is valid.
- the logo of the traffic data provider is shown. The subscription has expired.

The subscription expiry date is automatically displayed:

- one month before the expiry date
- one week before the expiry date
- on the expiry date





 The subscription can be extended (→ page 315).

Registering Live Traffic Information

Requirements:

- The vehicle is equipped with Live Traffic Information.
- You have a user account on the Mercedes me website.

The Live Traffic Information service must be registered. This secures the full period of three years.

-  Create a user account at Mercedes me at: <http://www.mercedes.me>. A valid email address is required for this.
-  Register the vehicle using the vehicle identification number (VIN).
-  **To carry out the registration yourself:** connect the vehicle with your Mercedes me user account in the Mercedes me portal. A code is sent to the multimedia system.
-  Enter the code into the multimedia system.
-  Accept the general and specific terms of use.

- ▶ **Registration in the Mercedes-Benz service centre:** have the connection carried out in a Mercedes-Benz service centre.

Extending a subscription

Requirements:

- The vehicle is equipped with Live Traffic Information.
 - You have a user account on the Mercedes me website.
- ▶ Call up the Mercedes me website.
 - ▶ Call up the Mercedes me user account.
 - ▶ Switch to the Mercedes me connect online store via the linked vehicle.
 - ▶ Select the Live Traffic Information service.
 - ▶ Select the renewal period.
 - ▶ Add the product to the shopping basket.
 - ▶ Accept the general and specific terms of use. Live Traffic Information remains activated for the selected extension period. Activation begins on the date of extension.

Showing traffic information

Requirements:

- The **Traffic** display is switched on (→ page 316).
- The following traffic displays are switched on (→ page 316):

Incidents

Freier Verkehrsfluss (Free traffic flow)

Delay

Multimedia system:



- ▶ Select **Navigation** (Navigation).

The map shows the following traffic information:

- traffic incidents, for example:
 - roadworks
 - road blocks
 - warning messages

When route guidance is active, the symbols for traffic incidents will be shown in

colour on the route. Off the route they are grey.

- warning message symbols:
 - symbol 
 - road safety notes, e.g. when approaching the end of a traffic jam

If the vehicle approaches a danger area on the route, a warning message is displayed on the map. In addition, an audible notification can follow a hazard warning.
- traffic flow information:
 - traffic jam (red line)
 - congested traffic conditions (orange line)
 - slow-moving traffic (yellow line)
 - free-flowing traffic (green line)
- display for traffic delays on the route lasting at least one minute

Displaying traffic incidents

Requirements:



- The [Incidents](#) display is switched on (→ page 316).

Multimedia system:

→  **Navigation** (Navigation) **Route symbol** **Traffic**

- ▶ Select [Traffic messages 3](#).
The list is sorted according to distance and shows the traffic incidents received.
The traffic incidents on the route are shown first.
A traffic incident shows the following information:
 - Street number
 - Traffic incident symbol
 - Cause
 - Distance from current vehicle position
- ▶ Select a traffic incident.
The detailed information, for example the route section, is shown.

Showing traffic incidents in the vicinity of the map

- ▶ Select a traffic incident symbol on the map.
The details about the traffic incident are displayed.
- ▶ Select .
- ▶ Select [Traffic incidents in vicinity](#).
The map shows the traffic incident symbols in the vicinity.
Traffic incident information is displayed in the status line:
 - Traffic incident symbol
 - Cause of the traffic incident, e.g. construction work
 - Warning message (highlighted red)
- ▶ **To select a traffic incident symbol:** select  or .
- ▶ **To select the map section:** tap on the multimedia system display.
or
- ▶ Press the Touch Control or the touchpad.
- ▶ Move the map

- ▶ **To return to the navigation map:** tap on .

or

- ▶ Press the  button on the Touch Control or on the touchpad.

Switching the traffic information display on

Multimedia system:

→  **Navigation** 

- ▶ Activate [Traffic](#).
With this option additional traffic flow information and delays can be shown.

Activating Incidents, Free Flow and Delay

- ▶ Select [Advanced settings](#).
- ▶ In the **TRAFFIC** category, activate the [Incidents](#), [Freier Verkehrsfluss](#) (Free traffic flow) and [Delay](#) entries.
If traffic information has been received, then traffic incidents such as roadworks, road blocks, local area reports (e.g. fog) and warning messages are displayed.

The traffic delay is displayed for the current route. Traffic delays lasting one minute or longer are taken into consideration.

Showing local area messages

Multimedia system:

  **Navigation** **Route**
 Icon **Traffic**

- ▶ Select **Area messages**.
Local area messages are shown, for example fog or heavy rain.
- ▶ Select a local area message.
The details are displayed.

Accepting a detour recommendation after a prompt

Requirements:

- **AFTER ASKING** is activated (→ page 300).
- route guidance is active.
- there are traffic reports for the current route.

If a new route with a shorter driving time is determined, the current and new routes will be shown.

 The notification is shown in another application. Confirm the notification.

- ▶ **To accept the new route:** select **Accept recommended detour**.
- ▶ **To maintain the current route:** select **Keep to current route**.

Car-to-X-Communication

Car-to-X-Communication overview

Requirements:

- The vehicle is equipped with a multimedia system featuring navigation and a communication module with an activated, integrated SIM card.
 - Car-to-X-Communication is activated.
-  Car-to-X-Communication is available in selected countries.

The communication module automatically establishes an Internet connection once the ignition is switched on. If there are any hazard warnings, they will be provided shortly thereafter. Depending on the mobile phone connection, the provi-

sion takes place from within a second up to about a minute.

- Hazards are recognised automatically by the vehicle or may be reported by the driver. These are then sent to vehicles with Car-to-X-Communication in the immediate vicinity.
- Current and precise details relating to hazard spots near the vehicle's current position are received.

This gives you sufficient time to adapt your driving style to the traffic conditions.

The use of Car-to-X-Communication requires the regular transmission of vehicle data to Daimler AG. The data is then immediately pseudonymised by Daimler AG. The vehicle data is deleted after an appropriate amount of time has elapsed (several weeks) and is not stored permanently.

-  Data which serves as identification is replaced during the pseudonymisation process. In this way, your identity is protected against access by unauthorised third parties.

Displaying hazard warnings

Multimedia system:



- ▶ Select **Navigation** (Navigation).
If hazard warnings are available these will be shown on the map.

The following hazard warnings are shown on the map:

- broken-down vehicles
- accidents
- hazardous weather
- general hazards
- hazard warning lights, if activated
- mobile roadworks

The display is not available in all regions.

In the Federal Republic of Germany the display is currently available in the Federal State of Hesse.

- ① If the vehicle is approaching a hazard spot with a vehicle speed of at least 60 km/h, the voice output "Traffic incident ahead" is issued.

The voice output is not issued for hazardous weather.

Sending hazard warnings

Automatically detected hazard warnings are sent by the vehicle.

- ▶ **To send hazard warnings yourself:** select ▶ **Navigation** (Navigation) ▶ **Route Icon** ▶ **Traffic**.
- ▶ Select **Traffic incident**.
A prompt is shown.
- ▶ Select **Yes**.
The **Thank you for supporting accident prevention** message appears.

Route guidance with augmented reality (AR)

Activating route guidance with augmented reality

Multimedia system:

- ▶ ▶ ▶ **Navigation** (Navigation) ▶

- ▶ Activate **Augmented Reality**.

When the option is activated, the video image from the camera shows the driver's view in the multimedia system display.

You can also select the following options:

- The video image will always be shown with the visible objects during route guidance.
- The video image will be shown with the visible objects instead of the navigation map before a turning manoeuvre.
After the turning manoeuvre, the navigation map will be shown again.

Examples of objects could be driving manoeuvre arrows, street names and house numbers, for example.

- ▶ Select **Advanced settings**.
- ▶ Select **Augmented Reality**.
- ▶ Select **Always** or **When cornering**.

Switching on display of POIs with augmented reality for route guidance

Requirements:

- Augmented reality is activated (→ page 318).

Multimedia system:

  **»» Navigation** (Navigation) **»»**  **»» Advanced settings** **»»** **Augmented Reality**

▶ Activate **POI symbols**.

When the option is switched on, the same POI symbols are shown in the video image as those configured for the navigation map.

Selecting a POI for route guidance with augmented reality

Requirements:

- Augmented reality is activated (→ page 318).
- The display of POIs is activated (→ page 318).

Multimedia system:

  **»» Navigation** (Navigation)

Selection of a POI is possible up to a vehicle speed of 50 km/h.

- ▶** Briefly press on a POI symbol.
or

- ▶** Select a POI when the next POIs are shown in a list during route guidance. The detailed view appears.
- ▶** Calculate the route (→ page 299).

Activating displays of street names and house numbers for route guidance with augmented reality

Requirements:

- Augmented reality is activated (→ page 318).

Multimedia system:

  **»» Navigation** (Navigation) **»»**  **»» Advanced settings** **»»** **Augmented Reality**

- ▶** Activate **Street names** and **Show house numbers**.
During route guidance, street names and house numbers are shown as objects in the video image.

Switching on display of traffic lights with augmented reality for route guidance

Requirements:

- Augmented reality is activated (→ page 318).

Multimedia system:

  **»» Navigation** (Navigation) **»»**  **»» Advanced settings** **»»** **Augmented Reality**

The video image will be enlarged to show traffic lights under the following conditions:

- The vehicle is standing at a junction in first position in the lane.
- The option is switched on.

When the vehicle pulls away the navigation map is shown again.

- ▶** Scroll up until **TRAFFIC LIGHT INDICATOR** is shown.
- ▶** Select **Off**, **AFTER ASKING** or **Automatic**.
If **AFTER ASKING** is set and a traffic light display is available, a message is shown. When the message is confirmed the video image shows a traffic light.

If **Automatic** is set the video image shows a traffic light if available.

Map and compass

Setting the map scale

Multimedia system:

→ 🏠 ➤ **Navigation** (Navigation)

Zooming in

▶ When the map is shown, tap twice quickly with one finger on the multimedia system display or the touchpad.

or

▶ Move two fingers apart on the multimedia system display or on the touchpad.

Zooming out

▶ Tap with two fingers on the multimedia system display or the touchpad.

or

▶ Move two fingers together on the multimedia system display or on the touchpad.

📘 You can set the unit of measurement of the map scale (→ page 286).

Moving the map

Multimedia system:

→ 🏠 ➤ **Navigation** (Navigation)

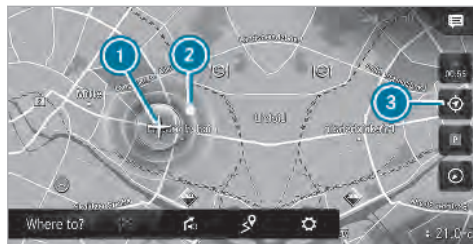

▶ **On the multimedia system display:** move a finger in any direction when the map is displayed.

▶ **On the touchpad:** call up the navigation menu by pressing.

▶ Swipe your finger up. Symbol ① appears on the map. The map can be moved.

▶ Touch the control element and move your finger in any direction.

The map moves in the corresponding direction under the crosshair. The more you move your finger away from the starting position, the faster the map moves. The position of ② shows the direction and the speed the map is moving.

When the map has been moved the following information appears in the status line, for example:

- The distance from the vehicle's current position is shown.
- Information about the current map position, e.g. the name of the road, is shown.

If you select ③, the map with the current position is shown again.

The following functions can be used:

- Select a destination on the map (→ page 298).
- Select a POI (→ page 296).
- Show traffic incidents on the map (→ page 316).

Rotating the map

- ▶ Move the map a little on the multimedia system display with your finger.
- ▶ With two fingers, rotate anti-clockwise or clockwise.

Selecting the map orientation

Multimedia system:

→  ▶▶ [Navigation](#) (Navigation) ▶▶  ▶▶ [Advanced settings](#)

- ▶ Swipe up until **MAP ORIENTATION** is shown.
- ▶ Select the map orientation. The • dot indicates the current setting.
 - **2D north up**: the 2D map view is displayed so that north is always at the top.
 - **2D heading up**: the 2D map view is aligned to the direction of travel.
 - **3D**: the 3D map view is aligned to the direction of travel.

Alternative using quick-access

- ▶ Repeatedly tap or press on the  compass symbol on the map. The view changes in the sequence **3D**, **2D heading up** to **2D north up**. If the map is moved, it can switch between **3D** and **2D north up**.

Selecting POI symbols for the map display

Multimedia system:

→  ▶▶ [Navigation](#) (Navigation) ▶▶  ▶▶ [Advanced settings](#)

POIs include filling stations and hotels, for example. These can be displayed as symbols on the map. Not all POIs are available everywhere.

Personal POIs are destinations which you have saved on a USB device, for example.

- ▶  The display of POI symbols on the map can be activated or deactivated as a favourite.
- ▶ Activate [POI symbols](#).

Configuring the map display



- ▶ Select  [POI symbols](#).

- ▶ Switch [Show all](#) on or off.
- ▶ Switch the categories (Quick POI) on or off.
- ▶ Select  [ALL CATEGORIES](#).
- ▶ Switch [Show all](#) on or off.

or

- ▶ Select the categories and sub-categories (if available) .
- ▶ Switch the categories and sub-categories (if available) on or off. The POI symbols for the selected categories are displayed.

Configuring personal POIs

- ▶ Select  [Personal POIs](#).
- ▶ Activate or deactivate the categories. When the category is switched on and the vehicle approaches a personal POI in this category, a visual and audible notification can be issued.
- ▶ **To set a notification when approaching:** select a category or a personal POI . A menu opens.
- ▶ Switch [Visual](#) and [Audible](#) on or off.

Resetting personal POIs

- ▶ Select .
- ▶ Select **RESET**.
The settings are reset to the standard settings.

Selecting text information

Multimedia system:

  ▶▶ **Navigation** (Navigation) ▶▶  ▶▶ **Advanced settings**

- ▶ Scroll up until **TEXT INFORMATION** is shown.
- ▶ Select **Current street**, **Geo-coordinates** or **None**.
Current street shows the street you are currently driving on at the bottom of the display. When the map is moved, the street name, the POI name or the area name appears under the crosshair.
Geo-coordinates displays the following information:
 - longitude and latitude
 - elevation

The elevation shown may deviate from the actual elevation.

- number of satellites from which a signal can be received
When the map is moved, this information does not appear.

None switches the display off.

Switching motorway information on/off

Multimedia system:

  ▶▶ **Navigation** (Navigation) ▶▶ 

- ▶ Switch **Motorway information** on or off. When the option is switched on, additional information about the motorway facilities ahead appears during the motorway journey. These include car parks, service stations and motorway exits, for example.

Displaying the next intersecting street

Requirements:

- Route guidance is not active.

Multimedia system:

  ▶▶ **Navigation** (Navigation) ▶▶  ▶▶ **Advanced settings**

- ▶ Swipe up until **TEXT INFORMATION** is shown.
- ▶ Activate **Next intersecting street**.
If the function is switched on and the journey continues without route guidance, the name of the next intersecting street will be displayed at the upper edge of the display.

Displaying the map version

Multimedia system:

  ▶▶ **Navigation** (Navigation) ▶▶  ▶▶ **Advanced settings**

- ▶ Swipe upwards and select **Map version**.
 Information about new versions of the digital map can be obtained from a Mercedes-Benz service centre.

Overview of avoiding an area

You can define areas along a route that you would like to avoid.

Motorways or multi-lane expressways, which are routed through an area to be avoided are taken into account for the route.

Avoiding a new area

Multimedia system:

  >> [Navigation](#) (Navigation) >> [Route Icon](#) >> [Avoid options](#) >> [Avoid areas](#)

- ▶ Select [Avoid new area](#).
- ▶ **To start in the map:** select [Using map](#).
- ▶ Move the map (→ page 320).
- ▶ **To start via destination search:** select [Search destination](#).
- ▶ Enter the address (→ page 293).
- ▶ Select the destination in the list or accept with .
- ▶ The map appears.
- ▶ **To show an area:** tap or press on the control element.
A red rectangle appears. This designates the area that should be avoided.

- ▶ **To change the map scale:** move two fingers apart or together on the multimedia system display or on the touchpad.
The map is zoomed in or out.

- ▶ **To set an area:** press on the central control element.
The area is entered into the list.

Changing an area

Multimedia system:

  >> [Navigation](#) (Navigation) >> [Route Icon](#) >> [Avoid options](#) >> [Avoid areas](#)

- ▶ Select an area in the list.
- ▶ Select [Edit](#).

Moving the area on the map

- ▶ Swipe in any direction on the central control element.

Changing the size of the area

- ▶ Press on the central control element.
- ▶ Swipe up or down on the central control element.

- ▶ Press on the central control element.

Taking the area for the route into account

- ▶ Select an area in the list.
- ▶ Activate [Avoid area](#).
If route guidance is active, a new route is calculated.

If there is no route yet, the setting is carried over to the next route guidance.

The route can include an area that is to be avoided in the following cases:

- the destination is located in an area that is to be avoided
- there is no sensible alternative route

Deleting one or all areas

Multimedia system:

  >> [Navigation](#) (Navigation) >> [Route Icon](#) >> [Avoid options](#) >> [Avoid areas](#)

Deleting an area

- ▶ Select an area in the list.
- ▶ Select [Delete](#).

▶ Confirm the prompt with **Yes**.

Deleting all areas

▶ Select .

▶ Select **Delete all**.

▶ Confirm the prompt with **Yes**.

Updating the map data

Updating at the Mercedes-Benz Service Centre

The digital maps generated by the map software become outdated in the same way as conventional road maps. Optimal route guidance can only be provided by the navigation system in conjunction with the most up-to-date map data. Information about new versions of the digital map can be obtained from a Mercedes-Benz service centre.

You can receive updates to the digital map there.

Online map update

 The online map update service is not available in all countries.

The online map update service from Mercedes me connect can be used to update the map data.

You can use the following update options:

- for one region (automatic map update)
- for several or all regions (manual map update)

The map data will first be downloaded onto a storage medium and then updated on the multimedia system.

The service must be activated at a Mercedes-Benz service centre in order to use automatic updates.

Further information on the online map update <http://www.mercedes.me>.

Further information on updates: http://manuals.daimler.com/baix/cars/connectme/de_DE/index.html.

Map data

Your vehicle is supplied with map data at the factory. Depending on the country, map data for your region is either pre-installed or the map data is supplied on a data storage medium. You

do not require an activation code for the map data which is provided with your vehicle.

If the map data on your vehicle has been installed at the factory and you wish to reinstall it, you do not need to enter the activation code.

An activation code is required for purchased map data.

Observe the following when entering the activation code:



- The activation code can be used for one vehicle
- The activation code is not transferable
- The activation code has six digits

In the event of the following problems, please contact a Mercedes-Benz service centre:

- The multimedia system does not accept the activation code
- You have lost the activation code

Displaying the compass

Multimedia system:

  **Navigation** (Navigation) **Route Icon** **Position**



Select **Compass**.

The compass display shows the following information:

- the current direction of travel with bearing (360° format) and compass direction
- longitude and latitude coordinates in degrees, minutes and seconds
- height (rounded)
- number of GPS satellites from which a signal can be received

Displaying Qibla

Multimedia system:

  **Navigation** (Navigation) **Route Icon** **Position**

Select **Qibla**.



The arrow on the compass shows the direction to Mecca in relation to the current direction of travel.

 The number of satellites received is shown.

 This function is not available in all countries.

Setting the map scale automatically

Multimedia system:

  **Navigation** (Navigation)  **Advanced settings**



The map scale is set automatically depending on your driving speed and the type of road.

 Activate **Auto zoom**.

 The automatically selected map scale can be changed manually. After a few seconds, this is automatically reset.

Displaying the satellite map

Multimedia system:

  **Navigation** (Navigation)  **Advanced settings**

 Switch **Satellite map** on or off.

If the option is activated, satellite maps are displayed in map scales from 2 km.

If the option is deactivated, satellite maps are not displayed in map scales from 2 km to 20 km.

 The satellite maps for these map scales are not available in all countries.

Showing the range

Requirements:

- The function is available.

Multimedia system:

  **Navigation** (Navigation)  **Advanced settings**

When the function is active the range is shown on the map.

- For petrol and diesel vehicles: green display
- For hybrid vehicles:
Total range: green display
Electrical range: blue display

When the lower reserve capacity is reached then the range display on the map is switched off.

 Swipe upwards and switch on **Range**.

Displaying weather information and other map contents

Multimedia system:

→  » [Navigation](#) (Navigation) »  » [Advanced settings](#)

▶ Select [ONLINE MAP CONTENTS](#).

The available services are displayed. The services are provided by Mercedes me connect.

▶ Switch on a service, e.g. [Weather](#).

Current weather information is displayed on the navigation map, e.g. temperature or cloud cover. The service information, e.g. weather symbols, is not shown in all map scales.

Further information about available services and about displaying information in the map scales: <http://www.mercedes.me>

The services are not available in every country.

① Requirements:

- You have a user account for the Mercedes me portal.

- The service is available.
- The service is activated.

Further information can be found at: <http://www.mercedes.me>

Showing map view in the multifunction display of the instrument cluster

Multimedia system:

→  » [Navigation](#) (Navigation) »  » [Advanced settings](#)

▶ Swipe upwards and select [Map view in instrument cluster](#).

▶ **To set the map scale automatically:** switch [Auto zoom](#) on or off.

When the option is activated, the map scale is set automatically depending on your driving speed and the type of road.

▶ **To select the map orientation:** select the map orientation.

The • dot indicates the current setting.

- [2D heading up](#): the 2D map view is aligned to the direction of travel.

- [2D north up](#): the 2D map view is displayed so that north is always at the top.
- [3D](#): the 3D map view is aligned to the direction of travel.

Parking service

Selecting parking options

Requirements:

- The navigation services option is available, subscribed to and activated in the Mercedes me portal.
The parking service is within the scope of the navigation service.
- [Parking](#) is activated (→ page 327).

Multimedia system:

→  » [Navigation](#) (Navigation)

▶ Tap on  in the map.

▶ Select a parking option.

The following information is displayed (if available):

- Destination address, distance from current vehicle position and arrival time
- Information on the multi-storey car park/car park

For example, opening times, parking changes, current occupancy, maximum parking time, maximum access height.

- Available payment options (Mercedes pay, coins, bank notes, cards)
- Details on parking tariffs
- Number of available parking spaces
- Payment method (e.g. at the parking machine)
- Services/facilities at the parking option

- Telephone number
- ▶ Calculating the route (→ page 299).

The following functions can also be selected (if available):

- Search for POIs in the vicinity.
- Save the destination.
- Place a call at the destination.
- Share the destination using NFC or QR code.
- Call up the web address.
- Show the destination on the map.



Displaying parking options on the map

Requirements:

- The navigation services option is available, subscribed to and activated in the Mercedes me portal.

The parking service is within the scope of the navigation service.

Multimedia system:

   **Navigation** (Navigation)  

▶ Activate **Parking**.

The parking options within the vicinity of the current vehicle position are shown.

Telephone

Telephone menu overview

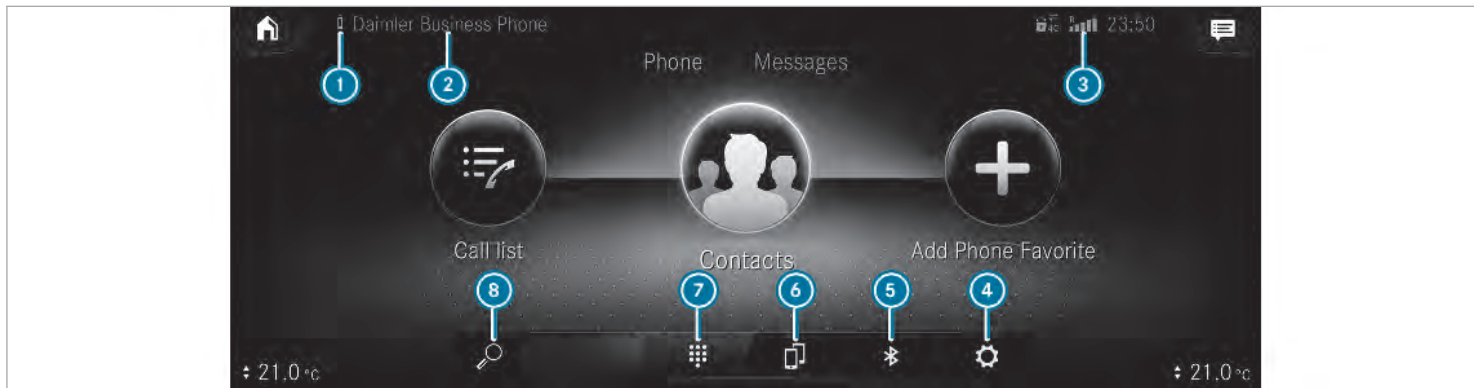

① Battery status of the connected mobile phone

② Bluetooth® device name of the currently connected mobile phone/the mobile phone in the foreground (two phone mode)

③ Signal strength of the mobile phone network

④ Options

⑤ Device manager

⑥ To switch mobile phones (two phone mode)

⑦ Numerical pad

⑧ contact search

Bluetooth® profile overview

Bluetooth® profile of the mobile phone	Function
PBAP (Phone Book Access Profile)	Contacts are automatically displayed in the multimedia system
MAP (Message Access Profile)	Message functions can be used

Telephony operating modes overview

The following telephone operating modes are available:

- A mobile phone is connected to the multimedia system via Bluetooth® (→ page 330).
- Two mobile phones are connected with the multimedia system via Bluetooth® (two phone mode).
 - You can use all the functions of the multimedia system with the mobile phone in the foreground.

- You can receive incoming calls and messages with the mobile phone in the background.

You can interchange the mobile phone in the foreground and background any time (→ page 331).

- ⓘ Irrespective of this, Bluetooth® audio functionality can be used with any mobile phone (→ page 365).

Notes on telephony

⚠ WARNING Risk of distraction from operating integrated communication equipment while the vehicle is in motion

If you operate communication equipment integrated in the vehicle when driving, you will be distracted from the traffic situation. This could also cause you to lose control of the vehicle.

- ▶ Only operate this equipment when the traffic situation permits.
- ▶ If you cannot be sure of this, stop the vehicle whilst paying attention to road

and traffic conditions and operate the equipment with the vehicle stationary.

⚠ WARNING Risk of distraction from operating mobile communication equipment while the vehicle is in motion

If you operate communication equipment integrated in the vehicle when driving, you will be distracted from the traffic situation. This could also cause you to lose control of the vehicle.

Only operate this equipment when the vehicle is stationary.

You must observe the legal requirements for the country in which you are currently driving when operating mobile communication equipment in the vehicle.

Further information can be obtained from a Mercedes-Benz service centre or at: <http://www.mercedes-benz.com/connect>.

Information on telephony

The following situations can lead to the call being disconnected while the vehicle is in motion:

- there is insufficient network coverage in the area
- you move from one transmission/reception station to another and no communication channels are free
- the SIM card used is not compatible with the network available
- a mobile phone with "Twincard" is logged into the network with the second SIM card at the same time

HD Voice®:

- To improve voice quality, the multimedia system supports telephone calls in HD Voice®.
- In order to use this function, the mobile phones and the mobile phone network provider of the person you are calling must support HD Voice®.

Depending on the quality of the connection, the voice quality may fluctuate.

Connecting a mobile phone

Requirements:

- Bluetooth® is activated on the mobile phone (see the manufacturer's operating instructions).
- Bluetooth® is activated on the multimedia system (→ page 283).

Multimedia system:



Searching for a mobile phone

- ▶ Select **Connect new device**.

Connecting a mobile phone (authorisation using Secure Simple Pairing)

- ▶ Select a mobile phone.
A code is displayed in the multimedia system and on the mobile phone.
- ▶ **If the codes match:** confirm the code on the mobile phone.

i For older mobile phone models, enter a one to sixteen-digit number code on the mobile phone and on the multimedia system for authorisation.

i Up to 15 mobile phones can be authorised on the multimedia system. Authorised mobile phones are reconnected automatically.

Connecting a second mobile phone (two phone mode)

Requirements:

- At least one mobile phone is already connected to the multimedia system via Bluetooth®.

Multimedia system:



- ▶ Select **Connect new device**.
- ▶ Select the mobile phone.
- ▶ Select **With <Mobile phone>**.
The selected mobile phone is connected to the multimedia system.

Functions of the mobile phone in two phone mode

Functions overview

Functions of the mobile phone in the foreground	Functions of the mobile phone in the background
Full range of functions	Incoming calls and messages

Interchanging mobile phones (two phone mode)

Multimedia system:

  **Telephone**



Select .

You can also interchange the two connected mobile phones in the following submenus:

- Contacts
- Call list
- Messages

After interchanging the mobile phones in one of the submenus, the mobile phone in the foreground is replaced by the mobile phone in the background.

Changing the function of a mobile phone

Multimedia system:

  **Telephone**

Activating a function

- ▶ Select a grey symbol in the line of a mobile phone.
The corresponding function is activated.

Deactivating a function

- ▶ **A function is active:** select the coloured symbol in the line of a mobile phone.
The mobile phone is disconnected from the multimedia system.
- ▶ **Several functions are active:** select a coloured symbol in the line of a mobile phone.
The corresponding function is deactivated.

Disconnecting/deauthorising a mobile phone

Multimedia system:

  **Telephone**

- ▶ Select  in the line of the mobile phone.
- ▶ **To disconnect:** select [Disconnect](#).
If applicable, the mobile phone will be automatically reconnected when the vehicle is next started.
- ▶ **To deauthorise:** select [De-authorise](#).

Information on Near Field Communication (NFC)

NFC enables short-range wireless data transfer or (re)connection of a mobile phone with the multimedia system.

The following functions are available without having authorised a mobile phone:

- Transferring a URL or a contact to be viewed in the multimedia system (see the manufacturer's operating instructions).
- Setting up the vehicle's Wi-Fi access data via the system settings (→ page 285).

Further information can be obtained at: <http://www.mercedes-benz.com/connect>

Using the mobile phone with Near Field Communication (NFC)

Requirements:

- NFC is activated on the mobile phone (see the manufacturer's operating instructions)
- The mobile phone's screen is switched on and unlocked (see the manufacturer's operating instructions)

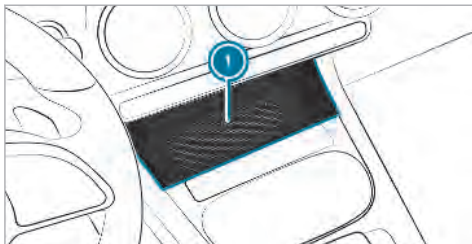

- ▶ **To connect a mobile phone:** hold the NFC area of the mobile phone (see manufactur-

er's operating instructions) on mat ① or place the mobile phone on it.

- ▶ Follow the additional prompts on the multimedia system display to connect the mobile phone. Connect the mobile phone in single telephone mode (→ page 330). Connect the mobile phone in two phone mode (→ page 330).
- ▶ **To replace a mobile phone:** hold the NFC area of the mobile phone (see manufacturer's operating instructions) on mat ① or place the mobile phone on it.
- ▶ Follow the additional prompts on the multimedia system display to replace the mobile phone in one or two phone mode (→ page 331).
- ▶ If required, confirm the prompts on your mobile phone (see the manufacturer's operating instructions).

Further information can be found at: <http://www.mercedes-benz.com/connect>

Setting the reception and transmission volume

Requirements:

- A mobile phone is connected (→ page 330).

Multimedia system:



This function ensures optimal language quality.

- ▶ Select in the line of the mobile phone.
- ▶ Select **Reception volume**, **Transmission volume** or **Ringtone**.
- ▶ Set the volume.

Further information on the recommended reception and transmission volume: <http://www.mercedes-benz.com/connect>

Setting the ringtone

Multimedia system:



- ▶ Select in the line of the mobile phone.
- ▶ Select **Ringtone**.
- ▶ Set the ringtone.

- i** If the mobile phone supports the transfer of the ringtone, you will hear the ringtone of the mobile phone instead of that of the vehicle.

Starting/stopping mobile phone voice recognition



Requirements:

- The mobile phone in the foreground is connected with the multimedia system (→ page 330).

Starting mobile phone voice recognition

- Press and hold the  button on the multi-function steering wheel for more than one second.
You can use mobile phone voice recognition.

Stopping mobile phone voice recognition

- Press the  or  button on the multi-function steering wheel.
- i** If a mobile phone is connected via Smartphone Integration, the voice recognition of this mobile phone is started or stopped.



Calls

Telephone operation

Multimedia system:



Making a call by entering the numbers

- Select .
- Enter a number.
- Select .
The call is made.

Accepting a call

- Select  **Accept.**

Rejecting a call





- Select  **Reject.**

Ending a call

- Select .

Activating functions during a call

The following functions are available during a call:

-  **End call**
-  **Microphone off**
-  **Numerical keypad** (show to send DTMF tones)
-  **Add call**
-  **Transfer to phone** (an active call in hands-free mode is transferred over to the telephone)
- Select a function.

Conducting calls with several participants

Requirements:

- There is an active call (→ page 333).
- Another call is being made.

Switching between calls

- ▶ Select the contact.
The selected call is active. The other call is on hold.

Activating or ending a call on hold

- ▶ Select [Continue call](#) or [End call](#).

Conducting a conference call

- ▶ Select  [Create conferen. call](#).
The new participant is included in the conference call.

Ending an active call

- ▶ Select  [End call](#).

 On some mobile phones, the call on hold is activated as soon as the active call is ended.

Accepting/rejecting a waiting call

Requirements:

- There is an active call (→ page 333).

If you receive a call while already in a call, a message is displayed.

Depending on the mobile phone and network operator you will hear a call-waiting sound. In addition, in two phone mode you will hear an acoustic signal when the call goes through to the other (not yet active) mobile phone.

- ▶ Select  [Accept](#).
The incoming call is active.

If only one mobile phone is connected with the multimedia system, the previous call will be put on hold.

If during a call you accept a call with the other mobile phone when in two phone mode then the existing call is ended.

- ▶ Select  [Reject](#).

 This function and behaviour depends on your mobile phone network provider and the mobile phone (see the manufacturer's operating instructions).

Contacts

Information about the contacts menu

The contacts menu contains all contacts from existing data sources, e.g. mobile phone or memory card.

Depending on the data source, you have the following number of contacts:

- Permanently saved contacts: 3,000 entries
- Contacts loaded from the mobile phone: 5,000 entries per mobile phone

From the contacts menu, you can perform the following actions:

- Make a call, for example call a contact (→ page 336)
- Navigation (→ page 298)
- Compose messages (→ page 339)
- Additional options(→ page 336)

If a mobile phone is connected to the multimedia system (→ page 330) and automatic call up (→ page 335) is activated, the mobile phone's contacts are displayed in the address book.

The multimedia system can show suggestions based on frequently used contacts as well as incoming and outgoing calls. (→ page 269). These are shown at the top of the contact list.

Downloading mobile phone contacts

Multimedia system:

↳  » Telephone »  » Device settings

Automatically

▶  Activate **Synchronise contacts automatically.**

Manually

▶  Deactivate **Synchronise contacts automatically.**
▶ Select **Synchronise contacts.**

Calling up contacts

Multimedia system:

↳  » Telephone » 

The following options can be used to search for contacts:

- searching by initials
 - searching by name
 - searching by phone number
- ▶ Enter characters into the search field.
▶ Select the contact.

A contact can contain the following details:

- phone numbers
- navigation addresses
- geo-coordinates
- Internet address
- E-mail address
- Voice Tag (if set)
- Relation (if set)

Editing the format of a contact's name

Multimedia system:



↳  » Telephone »  » General settings » Name format

The following options are available:

- Surname, first name
 - Surname First name
 - First name Surname
- ▶ Select an option.





Overview of importing contacts

Contacts from various sources

Source	Requirements:
 USB device	The USB device is connected with the USB port.
 Bluetooth® connection	<p>If the sending of vCards via Bluetooth® is supported, vCards can be received on mobile phones or netbooks, for example.</p> <p>Bluetooth® is activated in the multimedia system and on the respective device (see the manufacturer's operating instructions).</p>

Importing contacts into the contacts menu

Multimedia system:



  **Telephone**  **General settings** 

- Select an option.

Saving a mobile phone contact

Multimedia system:

  **Telephone** 

- Select   in the line of the mobile phone contact.
 - Select .
 - Select **Save in vehicle**.
 - Select **Yes**.
- The contact saved in the multimedia system

is identified by the  symbol.

Calling a contact

Multimedia system:

  **Telephone** 



- Select  **Search contacts** .

- ▶ Enter characters into the search field.
- ▶ Select the contact.
- ▶ Select the telephone number. The number is dialled.

Selecting further options in the contacts menu

Multimedia system:

  **Telephone** 

- ▶ Select  in the line of the contact.
- ▶ Select .

Depending on the stored data, the following options are available:

- **Add voice tag/Delete voice tag**
- **Set relationship/Remove relationship**
- **Send DTMF tones** (for a number with DTMF tones)
The function is available when a call is active.
- ▶ Select an option.

Selecting options for suggestions in the contacts menu

Requirements:

- a profile has been created (→ page 265).
- the [Allow contact suggestions](#) setting is switched on (→ page 269).

Multimedia system:

→  » Telephone

▶ Select  **Call list**.

▶ Select  in the line of a suggested contact.

The following options are available:

- [Save as favourite](#)
The suggestions are saved as global favourites and do not appear on the home screen.
- [Do not suggest](#)

▶ Select an option.

Deleting contacts



Requirements:

- The contacts are saved in the vehicle.
- To delete an individual contact, this has been imported manually into the vehicle.



Multimedia system:

→  » Telephone

Deleting all contacts

- ▶ Select .
- ▶ Select [General settings](#).
- ▶ Select [Delete contacts](#) .
- ▶ Select an option.

Deleting a contact

- ▶ Select .
- ▶ Select  in the line of the contact.
- ▶ Select .
- ▶ Select [Delete contacts](#).
- ▶ Select [Yes](#).

Saving a contact as a favourite

Multimedia system:

→  » Telephone »  [Add favourite](#)

- ▶ Select a contact.
- ▶ Select  in the line of the contact.
- ▶ Select the telephone number.
The contact is stored as a favourite on the home screen.

Deleting favourites

Multimedia system:

→  » Telephone

- ▶ Select a favourite on the home screen.
- ▶ Press and hold the favourite.
- ▶ Select [Delete](#).
- ▶ Select [Yes](#).

Deleting all favourites

- ▶ Select .
- ▶ Select [Device settings](#).
- ▶ Select [Delete all favourites](#).
- ▶ Select [OK](#).

Call list

Overview of the call list

Depending on whether your mobile phone supports the PBAP Bluetooth® profile or not, this can have different effects on the presentation and functions of the call list.

If the PBAP Bluetooth® profile is supported, the effects are as follows:

- The call lists from the mobile phone are displayed in the multimedia system.
- When connecting the mobile phone, you may have to confirm the connection for the PBAP Bluetooth® profile.

If the PBAP Bluetooth® profile is not supported, the effects are as follows:

- The multimedia system generates a call list independently as soon as calls are made in the vehicle.
- The call list is not synchronised with the call lists in the mobile phone.

The multimedia system can show suggestions based on frequently used contacts as well as

incoming and outgoing calls (→ page 269). These are shown at the top of the call list.

Making a call from the call list

Multimedia system:



 **Telephone**

- ▶ Select  **Call list** .
- ▶ Select an entry.
The call is made.

Calling up additional options in the call list

Multimedia system:

 **Telephone**

- ▶ Select  **Call list** .
- ▶ Select  in the line of an entry.
The following options are available:
 - **Open Contact** (if the contact is saved)
 - **Send message**



Selecting options for suggestions in the call list

Requirements:

- A profile has been created (→ page 265).
- The **Allow contact suggestions** setting is switched on (→ page 269).



Multimedia system:

 **Telephone**

- ▶ Select  **Call list** .
- ▶ Select  in the line of a suggested entry.
The following options are available:
 - **Save as favourite**
 - **Do not suggest**
- ▶ Select an option.

Deleting the call list

Multimedia system:

 **»» Telephone**  **»» Device settings**

- ▶ Select **Delete call lists**.
- ▶ Select **Yes**.

 This function is only available if your mobile phone does not support the PBAP Bluetooth® profile.

Text messages

Overview of message functions

In the messages menu you can receive and send text messages.

If the connected mobile phone supports the Bluetooth® MAP profile, the message function can be used on the multimedia system.

You can obtain further information about settings and supported functions of Bluetooth®-capable mobile phones from a Mercedes-Benz service centre or at: <http://www.mercedes-benz.com/connect>

Some mobile phones require further settings after being connected to the multimedia system (see manufacturer's operating instructions).

Configuring displayed messages

Multimedia system:

 **»» Telephone** **»» Messages**

- ▶ Select .

The following options are available:

- **All messages**
- **New and unread messages**
- **Messages while the vehicle is in motion**
- **Off** (the message function is no longer available.)

- ▶ Select a setting.

Reading messages

Multimedia system:

 **»» Telephone** **»» Messages**

- ▶ Select a contact.
The messaging history with this contact is shown.

Reading a text message

- ▶ Select a message.

Using the read-aloud function

- ▶ Select a message.



Select .
The message is read aloud.

Dictating and sending a new message

Requirements:

- There is an Internet connection.

Multimedia system:

 **»» Telephone** **»» Messages**



Select a new message.

Adding a recipient

- ▶ Select .
- ▶ Select a contact.

Dictating text



Select .

The dictating function is started.

▶ Say the message.

After the voice message has been processed, it is shown as text.

Sending a message



Select .

 When the vehicle is stationary you can use the keyboard to write a message. No Internet connection is required to use the keyboard.

Replying to a message in the messaging history

Multimedia system:

   [Telephone](#)  [Messages](#)

▶ Select a contact.

The messaging history opens.

▶ Dictate the text and send the message (→ page 339).

Using templates

Multimedia system:

  [Telephone](#)



Select .

▶ Select [Messages](#).

Using a template as a new message



Select  in the menu for a new message.

▶ Select a template.

Answering a message with a template

▶ Select a message sequence with a contact.

▶ Select .

▶ Select a template.

Forwarding a message

Multimedia system:

  [Telephone](#)  [Messages](#)

▶ Select a contact.

▶ Select a message.

▶ Select .

▶ Select [Forward](#).

Calling a message sender

Multimedia system:

  [Telephone](#)  [Messages](#)

▶ Select a contact.

▶ Select .

▶ Select [Call](#).

Using telephone numbers or URLs from a text message

Requirements:

- An Internet connection is required to call up a URL.

Multimedia system:

 **Telephone** **Messages**

- ▶ Select a contact.
- ▶ Select a message.
- ▶ Select a telephone number or a URL in the message.
If a URL is selected the web browser opens.
If a telephone number is selected the following options are available:
 - [Call](#)
 - [Write new text message](#)
- ▶ Select an option.

Deleting a message

Multimedia system:

 **Telephone** **Messages**

- ▶ Select a contact.
- ▶ Select a message.
- ▶ Select .
- ▶ **To delete the message:** select [Delete](#).

In Car Office

"In Car Office" functions

Using "In Car Office", you can connect your online services with the multimedia system.

The following functions are available:

- Display of upcoming meetings in the calendar
 - Selection of a meeting as a destination in the navigation
 - Display of upcoming telephone conferences
 - Display of participants in a telephone conference
 - Display and selection of calls to be made
-  Please note that certain functions are only available when the vehicle is stationary.

Calling up In Car Office

Requirements:

- A mobile phone is connected to the multimedia system as the main telephone.
- You have a user account on the website from Mercedes me (<http://www.mercedes.me>).

- The "In Car Office" service is activated in the Mercedes me portal.
- You have a user account with an online service, for example Office 365.



- ▶ Select [In Car Office](#).
You will see an appointments overview for the current day.
You can find the following displays in the appointments overview:
 - [All day](#): all-day appointment
 - [Lightning](#): appointment clash

Selecting a calendar entry function in "In Car Office"

Multimedia system:

 **In Car Office** **Calendar**

- ▶ Select an appointment.
The following functions are available:
 -  [Read aloud](#)

-  Call
-  Navigate
-  Reject

▶ Select a function.

Selecting the functions of Tasks & Calls

Multimedia system:

 ▶▶ In Car Office ▶▶ Tasks & calls

▶ Select an entry.

The following functions are available:

- Read aloud
- No translation
- Call

This option is only available for calls.

- Delete

▶ Select an option.

Apple CarPlay™

Overview of Apple CarPlay™

⚠ WARNING Risk of distraction from information systems and communications equipment

If you operate information and communication equipment integrated in the vehicle when driving, you will be distracted from the traffic situation. This could also cause you to lose control of the vehicle.

- ▶ Only operate this equipment when the traffic situation permits.
- ▶ If you cannot be sure of this, stop the vehicle whilst paying attention to road and traffic conditions and operate the equipment with the vehicle stationary.

You must observe the legal requirements for the country in which you are currently driving when operating the multimedia system. iPhone® functions can be used via the multimedia system using Apple CarPlay™. They are operated using the touchscreen, touchpad, Touch

Control or the Siri® voice-operated control system. You can activate the voice-operated control system by pressing and holding the  button on the multifunction steering wheel.

When using Apple CarPlay™ via the voice-operated control system, the multimedia system can still be operated via LINGUATRONIC (→ page 240).

Only one mobile phone at a time can be connected via Apple CarPlay™ to the multimedia system. Also for use of Apple CarPlay™ with two phone mode, only one additional mobile phone can be connected using Bluetooth® with the multimedia system.

The availability of Apple CarPlay™ may vary according to the country.

The service provider is responsible for this application and the services and content connected to it.

Information on Apple CarPlay™

When Apple CarPlay™ is being used, the iPod® media source is not available for the respective iPhone®.

Only one route guidance can be active at a time. If route guidance is active on the multimedia system, it is closed when route guidance is started on the mobile phone.

Connecting an iPhone® via Apple CarPlay™

Requirements:

- The current version of your device's operating system is being used (see the manufacturer's operating instructions).
- The full range of functions for Apple CarPlay™ is only available with an Internet connection.

- ▶ Connect the iPhone® to the USB port  on the multimedia system using a suitable cable (→ page 365).

Accepting/rejecting the data protection regulations

A message with the data protection regulations appears.

- ▶ Select [Accept & start](#).

- ❗ When the Apple CarPlay™ connection is active, you can switch [Start automatically](#) on or off.

Exiting Apple CarPlay™

- ▶ Press the  button.
- ❗ If Apple CarPlay™ was not displayed in the foreground before disconnecting, the application starts in the background when reconnected. You can call up Apple CarPlay™ in the main menu.

Calling up Apple CarPlay™ sound settings

- ▶ Select [Smartphone](#)  under the application.

Ending Apple CarPlay™

- ▶ Disconnect the connecting cable between the mobile phone and multimedia system. Mercedes-Benz recommends disconnecting the connecting cable only when the vehicle is stationary.

Android Auto

Android Auto overview

⚠ WARNING Risk of distraction from information systems and communications equipment

If you operate information and communication equipment integrated in the vehicle when driving, you will be distracted from the traffic situation. This could also cause you to lose control of the vehicle.

- ▶ Only operate this equipment when the traffic situation permits.
- ▶ If you cannot be sure of this, stop the vehicle whilst paying attention to road and traffic conditions and operate the equipment with the vehicle stationary.

You must observe the legal requirements for the country in which you are currently driving when operating the multimedia system.

Mobile phone functions can be used with Android Auto using the Android operating system on the multimedia system. It is operated

using the touchscreen or the voice-operated control system. You can activate the voice-operated control system by pressing and holding the  button on the multifunction steering wheel.

When using Android Auto via the voice-operated control system, the multimedia system can still be operated via LINGUATRONIC (→ page 240).

Only one mobile phone at a time can be connected via Android Auto to the multimedia system. Also for use of Android Auto with two phone mode, only one additional mobile phone can be connected using Bluetooth® with the multimedia system.

The availability of Android Auto and Android Auto Apps may vary according to the country.

The service provider is responsible for this application and the services and content connected to it.

Information on Android Auto

If a mobile phone is used with Android Auto, USB access using the media menu is not possible for this mobile phone.

Only one route guidance can be active at a time. If route guidance is active on the multimedia system, it is closed when route guidance is started on the mobile phone.

Connecting a mobile phone via Android Auto

Requirements:

- The first activation of Android Auto on the multimedia system must be carried out when the vehicle is stationary for safety reasons.
- The mobile phone supports Android Auto from Android 5.0.
- The Android Auto app is installed on the mobile phone.
- In order to use the telephone functions, the mobile phone must be connected to the multimedia system via Bluetooth® (→ page 330). If there was no prior Internet connection, this is established with the use of the mobile phone with Android Auto.
- The mobile phone is connected to the multimedia system via the USB port  using a suitable cable (→ page 365).

- The full range of functions for Android Auto is only possible with an Internet connection.

Multimedia system:

 [Smartphone](#)  [Android Auto](#)

Accepting/rejecting the data protection regulations

A message with the data protection regulations appears.

 Select [Accept & start](#).

 When the Android Auto connection is active, you can switch [Start automatically](#) on or off.

Exiting Android Auto

 Press the  button.

 If Android Auto was not displayed in the foreground before disconnecting, the application starts in the background when reconnected. You can call up Android Auto in the main menu.

Calling up the Android Auto sound settings

- ▶ Select **Smartphone**  under the application.

Ending Android Auto

- ▶ Disconnect the connecting cable between the mobile phone and multimedia system. Mercedes-Benz recommends disconnecting the connecting cable only when the vehicle is stationary.

Transferred vehicle data with Android Auto and Apple CarPlay™

Overview of transferred vehicle data

When using Android Auto or Apple CarPlay™, certain vehicle data is transferred to the mobile phone. This enables you to get the best out of selected mobile phone services. Vehicle data is not directly accessible.

The following system information is transmitted:

- Software release of the multimedia system
- System ID (anonymised)

The transfer of this data is used to optimise communication between the vehicle and the mobile phone.

To do this, and to assign several vehicles to the mobile phone, a vehicle identifier is randomly generated.

This has no connection to the vehicle identification number (VIN) and is deleted when the multimedia system is reset (→ page 289).

The following driving status data is transmitted:

- Transmission position engaged
- Distinction between parked, standstill, rolling and driving
- Day/night mode of the instrument cluster

The transfer of this data is used to alter how content is displayed to correspond to the driving situation.

The following position data is transmitted:

- Coordinates
- Speed
- Compass direction
- Acceleration direction

This data is only transferred while the navigation system is active, in order to improve it (e.g. so it can continue functioning when in a tunnel).

Mercedes me connect

Information on Mercedes me connect

Mercedes me connect provides the following services:

- Accident and breakdown management (me button or automatic accident or breakdown detection)
- Concierge Service (when the service is activated), appointment requests or similar (me button)
- Mercedes-Benz emergency call system (SOS button)

Mercedes me connect accident and breakdown management, the Mercedes me connect Concierge Service and the Mercedes-Benz emergency call centre are available for you around the clock.

The me button and the emergency call system can be found on the vehicle's overhead control panel (→ page 346).

You can also call the Mercedes-Benz Customer Centre using the multimedia system (→ page 346).

Please note that Mercedes me connect is a Mercedes-Benz service. In emergencies, always call the national emergency services first using the standard national emergency service phone numbers. In emergencies, you can also use the Mercedes-Benz emergency call system (→ page 349).

Further information on Mercedes me connect, the provided service scope and operation: http://manuals.daimler.com/baix/cars/connectme/de_DE/index.html

Calling the Mercedes-Benz Customer Centre using the multimedia system

Requirements for using Mercedes me connect services in the vehicle:

- You have access to a GSM network.
- The contract partner's GSM network coverage is available in the respective region.

- The ignition must be switched on so that vehicle data can be transferred automatically.

Multimedia system:



- ▶ Call **Mercedes me connect**. After confirmation, the multimedia system sends the required vehicle data.

The data transfer is shown in the multimedia system display. Then, you can select a service and be connected to a specialist at the Mercedes-Benz Customer Centre.

Further information on Mercedes me connect, the provided service scope and operation are available at: http://manuals.daimler.com/baix/cars/connectme/en_GB/index.html

Making a call via the overhead control panel

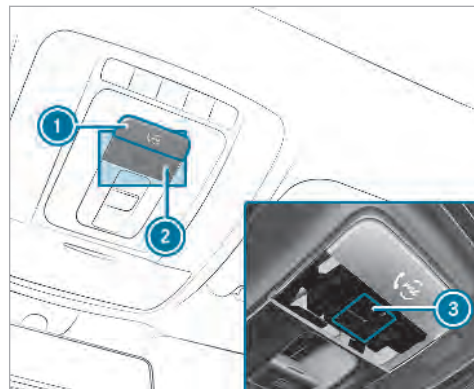

- ① Service call button (me button)
- ② SOS button cover
- ③ SOS button

- ▶ **To make a service call:** press me button ①.

- ▶ **To make an emergency call:** press SOS button cover ② briefly to open.
- ▶ Press and hold SOS button ③ for at least one second.

If a service call is active, an emergency call can still be triggered. This has priority over all other active calls.

Information about the service call using the me button

A call to the Mercedes-Benz Customer Centre has been initiated via the me button in the overhead control panel or the multimedia system.

In the event of a breakdown, you will get support:

- A qualified Mercedes-Benz technician carries out repairs on site and/or the vehicle will be towed to the nearest Mercedes-Benz service centre.

You may be charged for these services.

You can find information on the following topics:

- Activation of Mercedes me connect
- Operating the vehicle

- Nearest Mercedes-Benz service centre
- Other products and services from Mercedes-Benz

Data is transmitted during the connection to the Mercedes-Benz Customer Centre (→ page 348).

Information on Mercedes me connect accident management

The Mercedes me connect accident management is an extension of the Mercedes-Benz emergency call system (→ page 349).

An emergency call is made to the Mercedes-Benz emergency call centre after an accident:

- A voice connection is made to a contact person at the Mercedes-Benz emergency call centre.
- If necessary, the contact person at the Mercedes-Benz emergency call centre forwards the call to Mercedes me connect accident management.
- If necessary, the vehicle will be towed to a Mercedes-Benz service centre.

If the vehicle detects a minor accident, a message appears in the multimedia system.

The message is confirmed in the multimedia system:

- A voice connection is made to a contact person at Mercedes me connect accident management.
- If necessary, the vehicle will be towed to a Mercedes-Benz service centre.

Mercedes me connect service message

If you have activated the maintenance management service, relevant vehicle data is transferred automatically to the Mercedes-Benz Customer Centre. You will then receive individual recommendations regarding the maintenance of your vehicle.

Regardless of whether you have consented to the maintenance management service, the multimedia system reminds you after a certain amount of time that a service is due. A prompt appears asking if you would like to make an appointment.

▶ **To arrange a service appointment:** select **Call**. After your agreement the vehicle data is sent and a Mercedes-Benz Customer Centre employee deals with your appointment. The information is then sent to your desired service outlet.

This service outlet will then contact you within 24 hours.

❗ If you select **Later** after the service message appears, the message is hidden and reappears after a certain period of time.

Consenting to data transfer for Mercedes me connect

Requirements:

- There is an active service call via the multimedia system or the me button in the overhead control panel (→ page 346).

❗ In certain countries you must confirm the data transfer.

If the accident and breakdown service and Mercedes me connect Concierge Service are not activated on Mercedes me, the **Do you want to**

transmit vehicle data and the vehicle's position to the Mercedes-Benz Customer Centre in order to improve the processing of your request? message appears.

▶ Select **Yes**. Relevant identification data is transmitted automatically.

More information on Mercedes me: <http://www.mercedes.me>

Transferred data during a service call

When you make a service call via Mercedes me connect, various data will be transmitted.

Depending on which service is activated, the following data is transmitted when a call is made:

- Vehicle identification number
- Mercedes me customer identification number
- Reason for the initiation of the call
- Language set in the multimedia system
- Confirmation of the data protection prompt
- Current vehicle location

- Service and workshop code
- Selected data about the status of the vehicle

The following data is transmitted if no service is activated and the data protection prompt has been confirmed:

- Vehicle identification number
- Mercedes me customer identification number
- Reason for the initiation of the call
- Language set in the multimedia system
- Confirmation of the data protection prompt

The following data is transmitted if the data protection prompt has been rejected:

- Reason for initiating the call
- Rejection of the data protection prompt

Mercedes me and apps

Information about Mercedes me

When you log in with a user account to the Mercedes me portal, then services and offers from Mercedes-Benz will be available to you.

Availability is country-dependent.

For more information consult a Mercedes-Benz service centre or visit the Mercedes me portal: <http://me.secure.mercedes-benz.com>

Calling up the Mercedes me user account

Multimedia system:

  **Mercedes me & Apps**

Your vehicle is connected with a user account

- ▶ Select **Mercedes me**.
Information about the connected user account appears.

Your vehicle is not yet connected with a user account

- ▶ Select **Mercedes me**.
 - ▶ The instructions for creating a user account and connecting the vehicle with this follow on the multimedia system display.
-  If the Mercedes me app is available on a mobile phone, the vehicle connection can be accomplished using the QR code shown.

Calling up the Mercedes me services

Requirements:

- The vehicle is connected with the user account.

Multimedia system:

  **Mercedes me & Apps**

- ▶ Select **Services**.
Within the various categories you can see the Mercedes me services you have already purchased and also those still available to purchase.
To activate or deactivate the services, log in to your user account in the Mercedes me portal.

Deleting a connection between a user account and the vehicle

Multimedia system:

  **Mercedes me &**

- Apps** **Mercedes me**
- ▶ Select **Delete vehicle assignment**.
 - ▶ Enter the PIN of the connected user account.

Mercedes-Benz emergency call system

Information on the Mercedes-Benz emergency call system

The Mercedes-Benz emergency call system only functions in areas where mobile phone coverage is available from the relevant contract partner. Insufficient network coverage from the relevant contract partner may result in an emergency call not being transmitted.

The ignition must be switched on before an automatic emergency call can be made.

Overview of the Mercedes-Benz emergency call system

The Mercedes-Benz emergency call system can help to decisively reduce the time between an accident and the arrival of emergency services at the site of the accident. It helps locate an accident site in places that are difficult to access.

The emergency call can be made automatically (→ page 350) or manually. Only make emergency calls if you or others are in need of rescue. Do not make an emergency call in the event of a breakdown or a similar situation.

Notification in the multimedia system display:

SOS NOT READY: the ignition is not on or there is a malfunction with the emergency call system.

As soon as the emergency call system is available, the notification disappears.

During an active emergency call,  appears in the display.

You can find more information on the regional availability of the Mercedes-Benz emergency call system at: http://www.mercedes-benz.com/connect_ecall.

 If an emergency call is unavailable, a message to this effect also appears in the multifunction display of the instrument cluster.

Triggering an automatic emergency call

Requirements:

- The ignition is switched on.
- The starter battery is sufficiently charged.

If restraint systems such as airbags or seat belt tensioners have been activated after an acci-

dent, the Mercedes-Benz emergency call system may automatically initiate an emergency call.

The emergency call has been made:

- A voice connection is made to the Mercedes-Benz emergency call centre.
- A message with accident data is transmitted to the Mercedes-Benz emergency call centre.

The Mercedes-Benz emergency call centre can transmit the vehicle position data to one of the public emergency services call centres.

- Under certain circumstances data is also transmitted in the voice channel to the Mercedes-Benz emergency call centre.

This allows measures for rescue, recovery or towing to a Mercedes-Benz service centre to be initiated quickly.

If your vehicle is equipped with an SOS button in the overhead control panel, it flashes until the emergency call has been completed.

It is not possible to immediately end an automatic emergency call.

If the Mercedes-Benz emergency call system cannot connect to the Mercedes-Benz emergency call centre, the emergency call is automatically sent to the public emergency services call centre.

If no connection can be made to the public emergency services, a corresponding message appears in the display.

 Dial the emergency number 999 or **112** on your mobile phone.

If an emergency call has been initiated:

- Remain in the vehicle if the road and traffic conditions permit you to do so until a voice connection is established with the emergency call centre operator.
- On the basis of the call, the operator decides whether it is necessary to call rescue teams and/or the police to the accident site.
- If no vehicle occupant answers, an ambulance is sent to the vehicle immediately.

Triggering a manual emergency call

- ▶ If the vehicle has an SOS button in the overhead control panel: press and hold the button for at least one second.

The emergency call has been made:

- A voice connection is made to the Mercedes-Benz emergency call centre.
- If the road and traffic conditions permit, remain in the vehicle until a voice connection is established with the emergency call centre operator.
- On the basis of the call, the operator decides whether it is necessary to call rescue teams and/or the police to the accident site.
- A message with accident data is transmitted to the Mercedes-Benz emergency call centre. The Mercedes-Benz emergency call centre can transmit the vehicle position data to one of the public emergency services call centres.
- In certain situations data is also transmitted in the voice channel to the Mercedes-Benz emergency call centre.

This allows measures for rescue, recovery or towing to a Mercedes-Benz Service Centre to be initiated quickly.

If the Mercedes-Benz emergency call system cannot connect to the Mercedes-Benz emergency call centre, the emergency call is automatically sent to the public emergency services call centre.

If no connection can be made to the public emergency services, a corresponding message appears in the display of the multimedia system.

- ▶ Dial the emergency number 999 or **112** on your mobile phone.

Transmitted data with the Mercedes-Benz emergency call system

In the event of an automatic or manual emergency call, as well as for a **112** emergency call, data is transmitted to the Mercedes-Benz emergency call centre or the public emergency services call centre.

The following data is transmitted:

- the vehicle's GPS position data

- the last GPS position data on the route (a few 100 metres before the incident)
- direction of travel
- vehicle identification number
- the vehicle drive type
- the estimated number of people in the vehicle
- whether Mercedes me connect is available or not
- whether the emergency call was initiated manually or automatically
- the time of the accident
- the language setting on the multimedia system

For accident clarification purposes, the following measures can be taken up to an hour after the emergency call has been initiated:

- the current vehicle position can be called up
- a voice connection to the vehicle occupants can be established

- ❗ For Russia: various functions, e.g. receiving traffic information, cannot be performed for up to two hours after sending an emergency call.

Self-diagnosis display of the emergency call system (Russia)

Your car verifies the operability of the emergency call system each time the ignition is ON. In case of system failure, you will be informed with text message on the instrument cluster and with red indicator **SOS NOT READY** on the multimedia display.

Please, make sure, that during 3-10 seconds after switching ignition ON the red indicator **SOS NOT READY** in the upper right corner of the multimedia display is switched OFF, this means the emergency call system passed diagnostics successfully. If necessary, switch ON the multimedia display, if it was switched OFF before.

Starting/ending ERA-GLONASS test mode (Russia)

Requirements:

- The starter battery has sufficient charge.

- the ignition is switched on.
- The vehicle has been stationary for at least one minute.

▶ **To start the test mode:** press and hold the  button on the multifunction steering wheel for at least five seconds.

The test mode is started and automatically ends after the language test has been performed.

▶ **To end the test mode manually:** switch off the ignition.
The test mode is ended.

Online and Internet functions

Internet connection

Information on connecting to the Internet

⚠ WARNING Risk of distraction from information systems and communications equipment

If you operate information and communication equipment integrated in the vehicle

when driving, you will be distracted from the traffic situation. This could also cause you to lose control of the vehicle.

- ▶ Only operate this equipment when the traffic situation permits.
- ▶ If you cannot be sure of this, stop the vehicle whilst paying attention to road and traffic conditions and operate the equipment with the vehicle stationary.

You must observe the legal requirements for the country in which you are currently driving when operating the multimedia system.

To use Mercedes-Benz Apps and access the Internet, Mercedes me connect must be activated and operational. Furthermore, Mercedes me connect must be activated for Internet access.

Depending on the vehicle's equipment, you can establish an Internet connection in the following ways:

- **Vehicles with a communication module:** Internet use including Mercedes me connect services and data roaming (→ page 353).

- the Bluetooth® function is switched off on the mobile phone and the mobile phone is to be connected via Bluetooth®
- neither the mobile phone network nor the mobile phone allow simultaneous use of a telephone and an Internet connection
- the mobile phone has not been enabled for Internet access via Bluetooth®

If a mobile phone is connected to the multimedia system for the first time via Bluetooth®, you will be assisted through the process of setting up an Internet connection.

The Internet connection can also be configured manually.

Further information can be obtained at <http://www.mercedes-benz.com/connect> or from a Mercedes-Benz service centre.

Multimedia system:

 **▶▶ Settings ▶▶ System ▶▶ Wi-Fi & Bluetooth ▶▶ Internet settings ▶▶ Connect via Bluetooth**

- ▶ Select the mobile phone.
The Internet connection is established.

Establishing an automatic Internet connection

Multimedia system:

 **▶▶ Settings ▶▶ System ▶▶ Wi-Fi & Bluetooth ▶▶ Internet settings**

- ▶ Highlight the mobile phone.
- ▶ Select .

▶ Activate  **Permanent Internet connection.**

cancelling Internet access permission for a mobile phone

Multimedia system:

 **▶▶ Settings ▶▶ System ▶▶ Wi-Fi & Bluetooth ▶▶ Internet settings**

- ▶ Select  in the line of the mobile phone.
- ▶ Select **Delete configuration.**
- ▶ Select **Yes.**

Displaying mobile phone details

Multimedia system:

 **▶▶ Settings ▶▶ System ▶▶ Wi-Fi & Bluetooth ▶▶ Internet settings**

- ▶ Select  in the line of the mobile phone.
- ▶ Select **Details.**

Establishing an Internet connection

Multimedia system:

 **▶▶ Mercedes me & Apps**

- ▶ For example, select **Free Browser.**

- ① The multimedia system usually establishes the Internet connection automatically. If the multimedia system is not connected to the Internet, the Internet connection is established when an Internet application is used.

Setting automatic disconnection of the Internet connection

Multimedia system:

➔  ➔ Settings ➔ System ➔ Wi-Fi & Bluetooth ➔ Internet settings

- ▶ Select  in the line of the mobile phone.
- ▶ Select **Disconnect when inactive**.

The following options are available:

- 5 minutes
 - 10 minutes
 - 20 minutes
 - Unlimited
- ▶ Select an option.

Connection status

Connection status overview

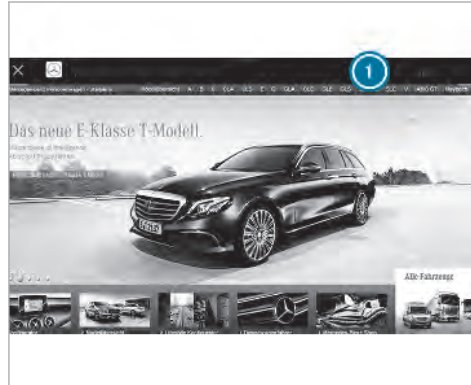

- ① Display of existing connection and reception field strength of the communication module or of the connected Bluetooth® device

Displaying the connection status

Multimedia system:

➔  ➔ Settings ➔ System ➔ Wi-Fi & Bluetooth

- ▶ Select **Internet status**.

- ① When connected via Wi-Fi or a Bluetooth® device, the approximate data volume transmitted is displayed. The exact values can be requested from your mobile phone network provider.

Web browser

Calling up a web page

⚠ WARNING Risk of distraction from information systems and communications equipment

If you operate information and communication equipment integrated in the vehicle when driving, you will be distracted from the traffic situation. This could also cause you to lose control of the vehicle.

- ▶ Only operate this equipment when the traffic situation permits.
- ▶ If you cannot be sure of this, stop the vehicle whilst paying attention to road and traffic conditions and operate the equipment with the vehicle stationary.

You must observe the legal requirements for the country in which you are currently driving when operating the multimedia system.

Multimedia system:



   Mercedes me & Apps   Browser

Calling up a new web page

- ▶ Select .
 - ▶ Enter a web address.
 - ▶ Select .
-  The function is country-dependent.

-  Websites cannot be shown while the vehicle is in motion.

Calling up a website from the browser history

- ▶ To call up the previous or next page from the history: select  or .

Web browser overview



- ① URL entry
- ② Bookmarks

- ③ Web page, back
- ④ Web page, forwards

- ⑤ To refresh/stop
- ⑥ Options



Calling up web browser options

Multimedia system:

  Mercedes me &
Apps   Browser  





The following functions are available:

- [Bookmarks](#)
- [Options](#) with the settings:
 - [Browser settings](#)
 - [Delete browser data](#)

-  Select an option.
-  Change the settings.

Calling up the web browser settings

Multimedia system:

  Mercedes me &
Apps   Browser    Browser
settings

The following functions are available:

- [Block popups](#)
- [Enable Javascript](#)
- [Enable cookies](#)

-  Switch a function on or off .



Deleting Internet history

Multimedia system:

  Mercedes me &
Apps   Browser    Delete
browser data

The following options are available:

- [All](#)
- [Cache](#)
- [Cookies](#)
- [Entered URLs](#)

-  Select an option.
-  Select [Yes](#).

Managing bookmarks

Multimedia system:



  Mercedes me &
Apps   Browser

-  Select .





Selecting a bookmark

-  Select an entry.





Creating a bookmark

-  Select [Aktuelle Seite zu Lesezeichen hinzufügen](#) (Add current page to the bookmarks).
-  Enter a name.
-  Select [Bestätigen](#) (Confirm).

Editing a bookmark

-  Select  after a bookmark.
-  Select [Edit](#).
-  Enter a name.
-  Select [Bestätigen](#) (Confirm).

Deleting a bookmark

-  Select  after a bookmark.
-  Select [Delete](#).
-  Select [Yes](#).

Closing the browser

Multimedia system:

-  ➤ Mercedes me & Apps ➤  Browser
- ▶ Select .

Internet radio

Calling up Internet radio

Requirements:

- There is an account on <http://www.mercedes.me>.

- The Internet radio service is activated.
 - The data volume is available.
Depending on the country, data volume may need to be purchased.
 - A fast Internet connection for data transmission free of interference.
-  The functions and services are country-dependent. For more information, consult a Mercedes-Benz service centre.

Multimedia system:

➤  ➤ Radio

▶ Select **TuneIn Radio**.

The Internet radio menu appears. The last station set starts playing.

 The connection quality depends on the local mobile phone reception.

Internet radio overview

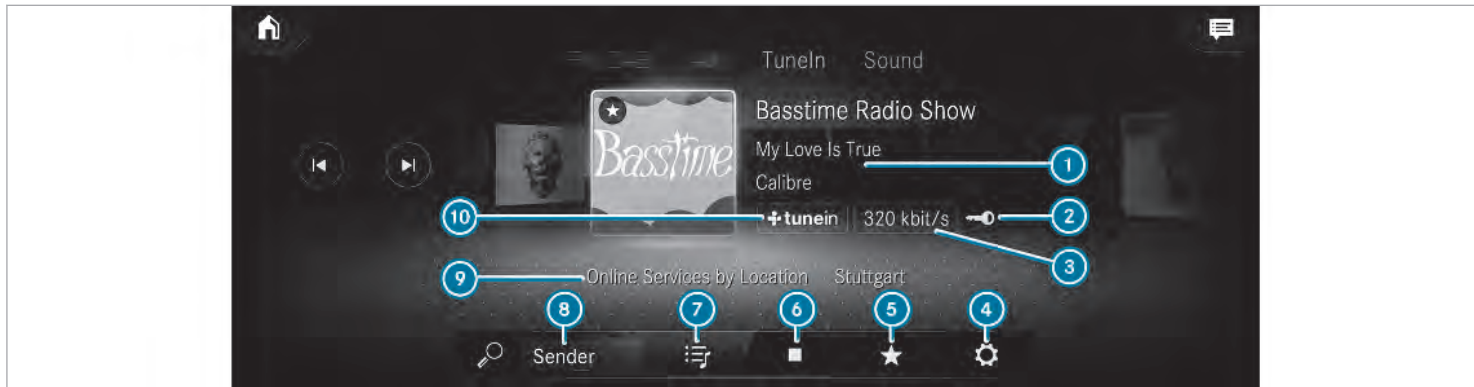

① Additional information on the current station

② Display (if connected to private user account)

③ Data transfer rate

④ Options

⑤ Favourites

⑥ To start/end

⑦ To browse

⑧ Search

⑨ Selected category

⑩ Internet radio provider

Selecting and connecting to Internet radio stations

Multimedia system:



- ▶ Select .
- ▶ Select a category.
- ▶ Select a station.
The connection is established automatically.

or

- ▶ Select the search field.
- ▶ Enter a station name using the entry field.
- ▶  A relatively large volume of data can be transmitted when using Internet radio.

Saving/deleting Internet radio stations as favourites

Multimedia system:



- ▶ Select a station.
- ▶ Select .
- The list of saved favourite stations appears.

- ▶ Select [Add to favourites](#).

or

- ▶ Create an account for the online provider (Tuneln radio) and then log in on the multimedia system.
Your favourites are imported to the multimedia system.

Deleting favourites

- ▶ Select a station.
- ▶ Select .
- ▶ Select [Delete favourite](#).

Setting Internet radio options

Multimedia system:



The following options are available:

- [Select stream](#): select the stream quality.
- [Login to Tuneln account](#): log in to your Tuneln user account.
- [Log out of account](#): log out of your Tuneln user account.
- ▶ Select an option.

Showing the station list for the last category selected

Multimedia system:



- ▶ Press the cover of the current station.
Depending on how the station was selected, a station list is shown.

Media

Information about media mode

Information about supported formats and data storage media

 **WARNING** Risk of distraction when handling data storage media

If you handle a data storage medium while driving, your attention is diverted from the traffic conditions. This could also cause you to lose control of the vehicle.

- ▶ Only handle a data storage medium when the vehicle is stationary.

The multimedia system supports the following formats and data media:

Permissible file systems	FAT32, exFaT, NTFS
Permissible data carriers	USB devices, iPod®/iPhone®, MTP devices, Bluetooth® audio equipment
Supported formats:	Audio: MP3, WMA, AAC, WAV, FLAC, ALAC Video: MPEG, AVI, DivX, MKV, MP4, M4V, WMV

- The multimedia system supports a total of up to 50,000 files.
- Data storage media up to 2 TB are supported (32-bit address space).

i Observe the following notes:

- Due to the large variety of available music and video files regarding encoders, sampling rates and data transfer rates, playback cannot always be guaranteed.

- Due to the wide range of USB devices available on the market, playback cannot be guaranteed for all USB devices.
- Videos up to FullHD (1920x1080) are supported.
- Copy-protected music and video files or DRM (Digital Rights Management) encrypted files cannot be played back.
- MP3 players must support Media Transfer Protocol (MTP).

Information on copyright protection and trademarks

Audio files that you create or reproduce yourself for playback are generally subject to copyright protection. In many countries, reproductions, even for private use, are not permitted without the prior consent of the copyright holder. Make sure that you know about the applicable copyright regulations and that you comply with these.



Manufactured under licence from Dolby Laboratories. Dolby, Dolby Audio and the double-D symbol are trademarks of Dolby Laboratories.



Gracenote, the Gracenote logo and logotype, "Powered by Gracenote", MusicID and Playlist Plus are either registered trademarks or trademarks of Gracenote, Inc. in the United States and/or other countries.

For DTS Patents, see <http://patents.dts.com>.
Manufactured under licence from DTS Licensing Limited. DTS, DTS-HD, the Symbol, & DTS and

the Symbol together are registered trademarks of DTS, Inc. © DTS, Inc. All Rights Reserved.

Connecting the data storage medium to the multimedia system

Connecting USB devices

! **NOTE** Damage caused by high temperatures

High temperatures can damage USB devices.

▶ Remove the USB device after use and take it out of the vehicle.

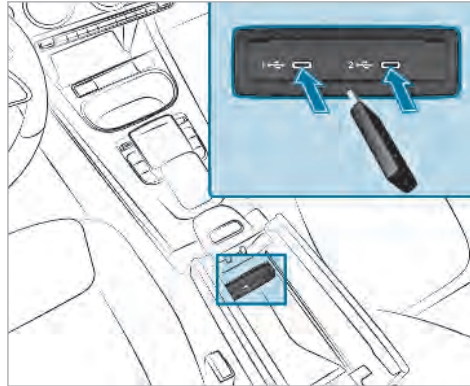

The multimedia connection unit is found in the stowage compartment under the armrest and has two USB ports. Depending on the vehicle's equipment, additional USB ports can be found in the stowage compartment of the centre console or rear folding compartment.

▶ Connect the USB device to the USB port.

Searching for and authorising Bluetooth® audio equipment

Requirements:

- Bluetooth® is activated on the multimedia system and audio equipment.
- The audio equipment supports the Bluetooth® audio profiles A2DP and AVRCP.
- The audio equipment is "visible" for other devices.

Multimedia system:

➔  ▶▶ Media ▶▶ Bluetooth ▶▶ 

Authorising new Bluetooth® audio equipment

- ▶ Select **Connect new device**.
Detected equipment is displayed in the device list.
- ▶ Select an audio device.
Authorisation starts. A code is displayed on the multimedia system and on the mobile phone.
- ▶ If the codes are identical, confirm on the audio equipment.

- ▶ Select **Only as Bluetooth audio device**.
The Bluetooth® audio equipment is connected with the multimedia system.

Connecting Bluetooth® audio equipment that has already been authorised

- ▶ Select a Bluetooth® audio device from the list.
Establishing a connection.

Starting media playback

A data storage medium is connected to the multimedia system.

Multimedia system:



- ▶ Select **USB** or **Bluetooth** as the media source.

Controlling media playback

Multimedia system:



- ▶ **To pause playback:** select

- ▶ **To continue playback:** select

- ▶ **To repeat a track:** select

For the repeat function there are the following settings:

- **Select once:** the active playlist is repeated.
- **Select twice:** the current track is repeated.
- **Select three times:** the repeat function is deactivated.

- ▶ **To play back tracks in random order:**

select

- ▶ **To wind a track forwards or backwards:** tap on the desired point on the timeline.

- ▶ **To select the next track:** select

- ▶ **To select the previous track:** select

- ▶ **To scroll through tracks quickly:** press and hold or .

- ▶ **To show the current track list:** select the track image shown.

Additional options

Multimedia system:



Calling up additional options

- ▶ Select .
The additional options are shown.

The following options are available:

- **Play similar tracks**
Select during playback of a track in order to create a playlist with similar tracks
- **Surprise mix**
A playlist with randomly selected tracks is created.
- **Add to favourite songs**
The current track is added to the favourite songs.
- **Delete from favourite songs**

The current track is removed from the favourite songs.

- ▶ Select an option.

Media search

Information about the search function in categories

Under  **My Music** you can search through all available media files. There are several categories available for selection. The categories shown depend on the connected device and data format.

Available categories with Bluetooth audio:

- [Current tracklist](#)

The folders and categories of the connected device are shown.

Available categories with audio files:

- [Current tracklist](#)
- [Playlists](#)
- [Folder](#)

- [Albums](#)
- [Artists](#)
- [Tracks](#)
- [Favourite songs](#)
- [Frequently played](#)
- [Most recently added](#)
- [Mood](#) (→ page 368).
- [Music genres](#)
- [Year](#)
- [Composers](#)
- [Select by cover](#)
- [Podcasts](#) (Apple® devices)
- [Audiobooks](#) (Apple® devices)

Available categories with video files:

- [Folder](#)
- [Videos](#)

 The categories are available as soon as the entire media content has been read in and analysed.

Starting a search in categories

Multimedia system:

  [Media](#)  [My Music](#)

- ▶ Select a category.
The media files are shown corresponding to the selected category, e.g. all albums will be shown for the [Albums](#) category.

Sorting results shown or playing back all media found

- ▶ Select .
- ▶ **To play back all results found in the category:** select [Play all](#).
If, for example, the album category is active, all albums found by the desired artist will be played back.
- ▶ **To sort results alphabetically:** select [Sort from A-Z](#).
- ▶ **To sort results in reverse alphabetical order:** select [Sort from Z-A](#).

 The available options depend on the selected category and the connected device.

Using the keyword search

Multimedia system:

 →  ▶▶ Media ▶▶ My Music

In the categories under  **My Music** you can use the keyword search with free text input to look for content.

- ▶ Select a category.
 - ▶ Select **Search**.
A keyboard for character entry appears.
 - ▶ Enter the term searched for.
-  The search begins with the first character entered. The more characters entered the more concrete the search results become.
- ▶ Select the desired entry from the result list. If the selected result is an album, song or a playback list then playback is started. If the

selected result is a new category then this is opened in the search.

Searching for a track according to mood

Multimedia system:

 →  ▶▶ Media ▶▶ My Music

Using the My Music search, you can find music tracks suitable for a mood.

- ▶ Select **Mood**.
A grid with the following moods appears:
 - **Positive**
 - **Calm**
 - **Dark**
 - **Energetic**
- ▶ Pull the controller to the desired position. The system searches for tracks that are suitable for the mood entered.

Making video settings

Multimedia system:

 →  ▶▶ Media ▶▶ 

- ▶ Select **Video settings**.
- ▶ Select an aspect ratio.

Setting full screen



- ▶ Select .

Radio

Switching on the radio

Multimedia system:

 →  ▶▶ Radio

- ▶ Alternatively: press the   button. The radio display appears. You will hear the last station played on the last frequency band selected.

Radio overview



- ① Active frequency band
- ② Station name or set frequency
- ③ Artist, title, album and radio text

- ④ Options
- ⑤ Full screen/DAB slideshow
- ⑥ Mute function

- ⑦ Station list
- ⑧ Search

Setting the frequency band

Multimedia system:



- ▶ Select a frequency band.

Selecting a radio station

Multimedia system:



- ▶ Swipe to the left or right on the control element.

Calling up the radio station list

Multimedia system:



- ▶ Select . The station list appears.
- ▶ Select a station.



Sorting station lists according to categories (only for FM/DAB)

- ▶ Select **Category**.
- ▶ Select a category.

Searching for radio stations using station names or direct frequency entry

Multimedia system:



- ▶ . Select .
- ▶ Enter a station name or frequency.
- ▶ Select a station.

Storing radio stations

Multimedia system:



- ▶ Select a radio station.

Memory slots are available in station presets

- ▶ Select .

Replacing an entry in the station presets

- ▶ Press and hold on an entry in the station presets.
- ▶ Select **Yes**.

Editing station presets

Multimedia system:



Moving stations:

- ▶ Press and hold a stored station.
- ▶ Select **Move**.
- ▶ Move the station to the new position.

Deleting stations:

- ▶ Press and hold a station.
- ▶ Select **Delete**.

Replacing a station:

- ▶ Press and hold a station.

- ▶ Select **Replace radio station**.

Calling up a slide show (FM/DAB radio mode)

Multimedia system:



The slide show displays additional information provided by the station as an image. This can include logos, album covers, music tracks, programmes, news or service information, for example.

- ▶ Select .

Activating or deactivating the frequency fix function

Multimedia system:



- ▶ Select **Frequency fix** to switch on or off. If the function is activated, the set frequency is kept even if the reception is poor.

Activating/deactivating traffic announcements

Multimedia system:



- ▶ Switch **Traffic announcements** on or off.

Setting the traffic information service volume increase

Multimedia system:



- ▶ Select **Other sound settings**.
- ▶ Select **Navigation and traffic announcements**.
- ▶ Select **TRAFFIC ANNOUNCEMENTS VOLUME INCREASE**.
- ▶ Set a value.
- ▶ To adopt the value: select .

Editing the voice tag function

Multimedia system:



- ▶ Select **Voice tag**.
- ▶ Select **Hinzufügen** (Add), **Löschen** (Delete) or **Anhören** (Listen to).

Displaying radio text

Multimedia system:



- ▶ Switch **Display radio text information** on or off.

Sound

Tone settings

Information about the sound system

The sound system has a total output of 100 watts and is equipped with 6 speakers. It is available for all functions in the radio and media modes.

Calling up the sound menu

Multimedia system:

The following functions are available:

- Equaliser
- Balance and Fader
- Auto. volume adjustment
- Other sound settings

 Select a sound menu.

Adjusting treble, mid-range and bass settings

Multimedia system:

 Set TREBLE, MID or BASS.

Activating/deactivating automatic volume adjustment

Multimedia system:

Automatic volume adjustment compensates for differing volumes when changing between audio sources.

 Switch Auto. volume adjustment on or off.

Adjusting the balance/fader

Multimedia system:

 Adjust the balance and fader.

Burmester® surround sound system

Information about the Burmester® surround sound system

The Burmester® surround sound system has a total output of 590 watts and is equipped with 12 speakers. It is available for all functions in the radio and media modes.

Calling up the sound menu in the Burmester® surround sound system

Multimedia system:

The following functions are available:

- Soundsets
- Equaliser
- Sound focus
- Automatic volume adjustment

 Select a function.

Adjusting the treble, mid and bass settings on the Burmester® surround sound system

Multimedia system:

 Set TREBLE, MID or BASS.

Activating/deactivating volume adjustment in the Burmester® surround sound system

Multimedia system:



▶▶ Auto. volume adjustment

Automatic volume adjustment compensates for differing volumes when changing between audio sources.

▶ Activate or deactivate the function.

Adjusting the balance/fader in the Burmester® surround sound system

Multimedia system:



▶ Adjust the balance and fader.

Switching surround sound on/off in the Burmester® surround sound system

Multimedia system:



▶ Select Pure or Surround.

Adjusting the sound focus in the Burmester® surround sound system

Multimedia system:



▶ Select a position for the sound focus or All seats.

Advanced sound system

Information about the Advanced sound system

The Advanced sound system has a total output of 225watts and is equipped with 10 speakers. It is available for all functions in the radio and media modes.

Calling up the sound menu in the Advanced sound system

Multimedia system:



The following functions are available:

- Equaliser
- Balance and Fader
- Auto. volume adjustment

- [Other sound settings](#)

▶ Select a function.

Adjusting treble, mid-range and bass settings in the Advanced sound system

Multimedia system:



▶ Set TREBLE, MID or BASS.

Switching volume adjustment in the Advanced sound system on/off

Multimedia system:



Auto. volume adjustment

Automatic volume adjustment compensates for differing volumes when changing between audio sources.

▶ Switch Auto. volume adjustment on or off.

Setting the balance/fader in the Advanced sound system

Multimedia system:



▶ Adjust the balance and fader.

ASSYST PLUS service interval display

Function of the ASSYST PLUS service interval display

The ASSYST PLUS service interval display in the instrument display provides information on the remaining time or distance before the next service due date.

You can hide this service message using the back button on the left-hand side of the steering wheel.

You can obtain further information concerning the servicing of your vehicle from a qualified specialist workshop, e.g. a Mercedes-Benz Service Centre.

Displaying the service due date

On-board computer:

↩ Service ▶ ASSYST PLUS

The next service due date is displayed.

▶ **To exit the display:** press the back button on the left-hand side of the steering wheel.

Be sure to observe the following related topic:

- Operating the on-board computer (→ page 229).

Carrying out maintenance work at regular intervals

! **NOTE** Premature wear through failure to observe service due dates

Service work which is not carried out at the right time or incompletely can lead to increased wear and damage to the vehicle.

- ▶ Always observe the prescribed service intervals.
- ▶ Always have the prescribed service work carried out at a qualified specialist workshop.

Special service requirements

The prescribed service interval is based on normal operation of the vehicle. Maintenance work will need to be performed more often if the vehi-

cle is operated under arduous conditions or increased loads.

Examples of arduous operating conditions:

- regular city driving with frequent intermediate stops
- mainly short-distance driving
- frequent operation in mountainous terrain or on poor road surfaces
- when the engine is often left idling for long periods
- operation in particularly dusty conditions and/or if air-recirculation mode is frequently used

In these or similar operating conditions, have the interior air filter, engine air cleaner, engine oil and oil filter etc. changed more frequently. The tyres must be checked more frequently if the vehicle is operated under increased loads. Further information can be obtained at a qualified specialist workshop.

Battery disconnection periods

The ASSYST PLUS service interval display can only calculate the service due date when the battery is connected.

- ▶ Note down the service due date displayed on the instrument display before disconnecting the battery (→ page 374).

Engine compartment

Active bonnet (pedestrian protection)

Operation of the active bonnet (pedestrian protection)

In certain accident situations, the risk of injury to pedestrians can be reduced by the actuation of the active bonnet. The rear area of the engine bonnet is raised by approximately 70 mm.

For the drive to the workshop, reset the triggered active bonnet yourself. After the active bonnet has been triggered, pedestrian protection may be limited.

A qualified specialist workshop must re-instate the full functionality of the active bonnet.

The active bonnet is not available in all countries.

Resetting the active bonnet

⚠ WARNING Danger of burns from hot component parts in the engine compartment

Certain component parts in the engine compartment may be very hot, e.g. the engine, the radiator and parts of the exhaust system.

- ▶ Let the engine cool down and only touch the component parts described below:

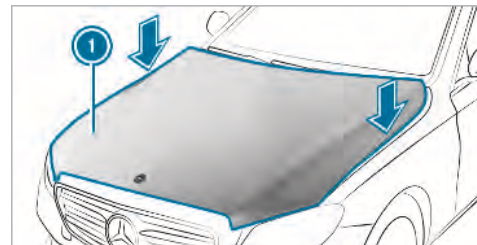

- ▶ With your hand flat, push down active bonnet ① in the area around the hinges on both sides (arrows). In doing so, the actuator is depressurised and you may hear a hissing sound. The engine bonnet must engage in position.
- ▶ If the active bonnet can be raised slightly at the rear in the area of the hinges, repeat the step until it engages correctly.

Opening/closing the bonnet

⚠ WARNING Risk of accident due to driving with the engine bonnet unlocked

An unlocked engine bonnet may open up when the vehicle is in motion and block your view.

- ▶ Never unlock the engine bonnet when driving.
- ▶ Before every trip, ensure that the engine bonnet is locked.

⚠ WARNING Risk of accident and injury when opening and closing the engine bonnet

When opening or closing the engine bonnet, it may suddenly drop into the end position.

There is a risk of injury for anyone in the engine bonnet's range of movement.

- ▶ Only open or close the engine bonnet when there are no persons in the engine bonnet's range of movement.

⚠ WARNING Danger of burns when opening the bonnet

If you open the engine bonnet when the engine has overheated or during a fire in the engine compartment, you could come into contact with hot gases or other escaping operating fluids.

- ▶ Before opening the bonnet, allow the engine to cool down.
- ▶ In the event of a fire in the engine compartment, keep the engine bonnet closed and call the fire service.

⚠ WARNING Risk of injury due to moving parts

Certain components in the engine compartment may continue to move or suddenly move again even after the ignition has been switched off, e.g. the cooler fan.

Make sure of the following before performing tasks in the engine compartment:

- ▶ Switch the ignition off.

- ▶ Never touch the danger zone surrounding moving component parts, e.g. the rotation area of the fan.
- ▶ Remove jewellery and watches.
- ▶ Keep items of clothing and hair away from moving parts.

⚠ WARNING Risk of injury from touching component parts under voltage

The ignition system and the fuel injection system work under high voltage. If you touch component parts which are under voltage, you could receive an electric shock.

- ▶ Never touch components of the ignition system or the fuel injection system when the ignition is switched on.

⚠ WARNING Danger of burns from hot component parts in the engine compartment

Certain component parts in the engine compartment may be very hot, e.g. the engine,

the radiator and parts of the exhaust system.

- ▶ Let the engine cool down and only touch the component parts described below:

⚠ WARNING Risk of injury from using the windscreen wipers while the engine bonnet is open

When the engine bonnet is open, and the windscreen wipers are set in motion, you can be trapped by the wiper linkage.

- ▶ Always switch off the windscreen wipers and ignition before opening the engine bonnet.

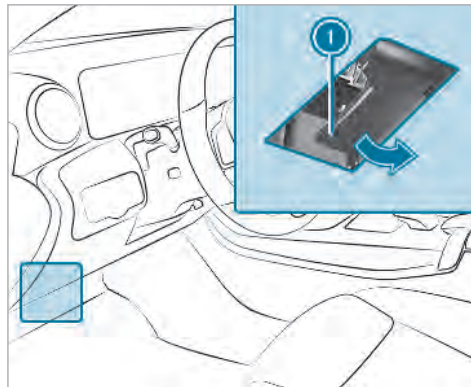

- ▶ **To open:** pull lever ① to release the engine bonnet.

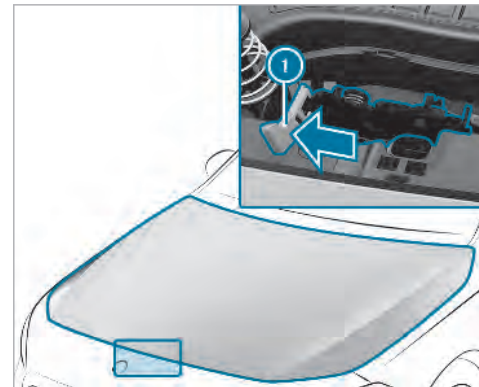

- ▶ Push the yellow handle ① of the bonnet catch to the left as far as it will go and lift the bonnet until it is automatically raised by the pneumatic strut.
- ▶ **To close:** lower the bonnet and let it fall from a height of approximately 20 cm.
- ▶ If the bonnet can still be lifted slightly, open the bonnet again and close it with a little force until it engages correctly.

Engine oil

Checking the engine oil level with an on-board computer

The engine oil level is determined during driving. The oil level display is only available after a driving time of up to 30 minutes and if the ignition is switched on, depending on the driving profile.

It is not possible to correctly measure the oil level if:

- the vehicle is not level during the measuring process.
- the bonnet was previously opened.

The engine must be restarted and the engine oil level will be determined again when driving.

On-board computer:

↪ **Service** ▶ **Engine oil level:**

You will see one of the following messages in the multifunction display:

- ▶ **Engine oil level Measuring now:** measurement of the oil level is not yet possible. Repeat the request after a maximum of 30 minutes' driving.

- ▶ **Engine oil level OK** and the bar display for indicating the oil level in the multifunction display is green and is between "min" and "max": the oil level is correct.
- ▶ **Engine oil level Add 1,0 l** and the bar display for indicating the oil level in the multifunction display is orange and is below "min": top up with 1 l of engine oil.
- ▶ **Reduce engine oil level** and the bar display for indicating the oil level in the multifunction display is orange and is above "max": drain off the excess engine oil. Consult a qualified specialist workshop.
- ▶ **For engine oil level turn on ignition:** switch on the ignition to check the engine oil level.
- ▶ **Engine oil level System inoperative:** sensor faulty or not inserted. Consult a qualified specialist workshop.
- ▶ **Engine oil level System currently unavail.:** close the bonnet.

Topping up engine oil

⚠ WARNING Danger of burns from hot component parts in the engine compartment

Certain component parts in the engine compartment may be very hot, e.g. the engine, the radiator and parts of the exhaust system.

- ▶ Let the engine cool down and only touch the component parts described below:

⚠ WARNING Risk of fire and injury from engine oil

If engine oil comes into contact with hot component parts in the engine compartment, it may ignite.

- ▶ Make sure that no engine oil is spilled next to the filler opening.
- ▶ Allow the engine to cool off and thoroughly clean the engine oil from component parts before starting the vehicle.

! **NOTE** Engine damage caused by an incorrect oil filter, incorrect oil or additives

- ▶ Do not use engine oils or oil filters which do not correspond to the specifications explicitly prescribed for the service intervals.
- ▶ Do not alter the engine oil or oil filter in order to achieve longer change intervals than prescribed.
- ▶ Do not use additives.
- ▶ Follow the instructions in the service interval display regarding the oil change.

! **NOTE** Damage caused by topping up too much engine oil

Topping up too much engine oil can cause damage to the engine or the catalytic converter.

- ▶ Have excess engine oil removed at a qualified specialist workshop.

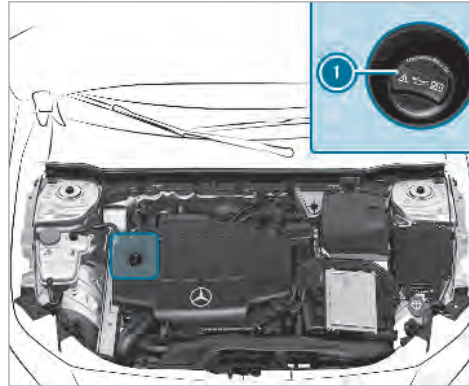

- ▶ Turn cap ① anti-clockwise and remove it.
- ▶ Top up the engine oil.
- ▶ Replace cap ① and turn it clockwise as far as it will go.
- ▶ Check the oil level again. Checking the engine oil level with an on-board computer(→ page 378).

Checking the coolant level

! **WARNING** Danger of burns from hot component parts in the engine compartment

Certain component parts in the engine compartment may be very hot, e.g. the engine, the radiator and parts of the exhaust system.

- ▶ Let the engine cool down and only touch the component parts described below:

! **WARNING** Risk of scalding from hot coolant

The engine cooling system is pressurised, particularly when the engine is warm. If you open the cap, you could be scalded by hot coolant spraying out.

- ▶ Let the engine cool down before opening the cap.
- ▶ When opening the cap, wear gloves and safety glasses.

- ▶ Open the cap slowly to release pressure.

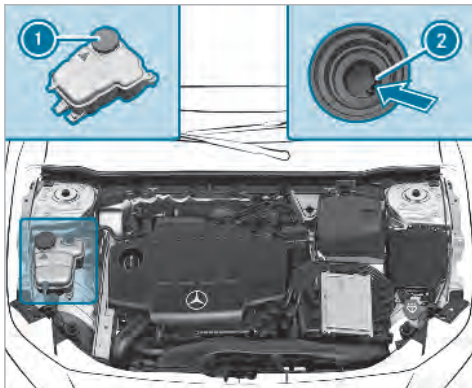

- ▶ Park the vehicle on a level surface.
- ▶ Check the coolant temperature display in the instrument cluster. The coolant temperature must be below 70 °C.

- ▶ Slowly turn cap ① anti-clockwise to relieve overpressure.
- ▶ Continue turning cap ① anti-clockwise and remove it.

The coolant level is correct:

- if the engine is cold, up to marker bar ②.
- if the engine is warm, up to 1.5 cm over marker bar ②.
- ▶ If necessary, top up with coolant that has been approved by Mercedes-Benz.
 - Further information on coolant (→ page 438)

Topping up the windscreen washer system

- ⚠ **WARNING** Danger of burns from hot component parts in the engine compartment

Certain component parts in the engine compartment may be very hot, e.g. the engine, the radiator and parts of the exhaust system.

- ▶ Let the engine cool down and only touch the component parts described below:

- ⚠ **WARNING** Danger of burns when opening the bonnet

If you open the engine bonnet when the engine has overheated or during a fire in the engine compartment, you could come into contact with hot gases or other escaping operating fluids.

- ▶ Before opening the bonnet, allow the engine to cool down.
- ▶ In the event of a fire in the engine compartment, keep the engine bonnet closed and call the fire service.

- ⚠ **WARNING** - Risk of fire and injury due to windscreen washer concentrate

Windscreen washer concentrate is highly flammable. It could ignite if it comes into contact with hot engine component parts or the exhaust system.

- ▶ Make sure that no windscreen washer concentrate spills out next to the filler opening.

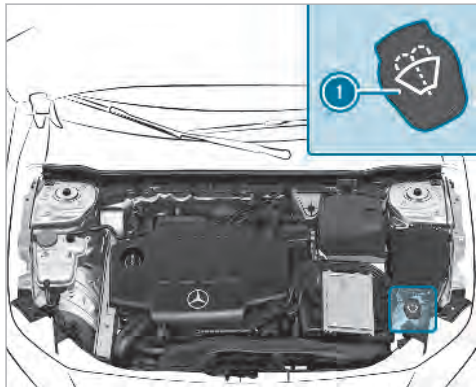

- ▶ Remove cap ① by the tab.
- ▶ Top up the washer fluid.

Cleaning and care

Information on washing the vehicle in a car wash

⚠ WARNING Risk of an accident due to reduced braking power after washing the vehicle

Braking efficiency is reduced after washing the vehicle.

- ▶ After the vehicle has been washed, brake carefully while paying attention to the traffic conditions until braking power has been fully restored.

To avoid damage to your vehicle when using a car wash, ensure the following beforehand:

- Active Distance Assist DISTRONIC and the HOLD function are deactivated.
- the 360° camera or the reversing camera is switched off.
- the side windows and sliding sunroof are completely closed.

- the blower for the ventilation/heating is switched off.
 - the windscreen wiper switch is in position **0**.
 - in car washes with a towing mechanism: neutral **N** is engaged.
 - The key is at a distance of at least 3 m away from the vehicle, otherwise the tailgate could open unintentionally.
- ① If, after the car wash, you remove the wax from the windscreen and wiper rubbers, this will prevent smearing and reduce wiper noise.

Information on using a high-pressure cleaner

⚠ WARNING Risk of an accident when using high-pressure cleaners with circular jet nozzles

The water jet of a circular jet nozzle (dirt grinder) can cause externally invisible damage to the tyres or chassis parts.

Components damaged in this way may unexpectedly fail.

- ▶ Do not use high-pressure cleaners with circular jet nozzles to clean the vehicle.
- ▶ Have damaged tyres or chassis parts replaced immediately.

To avoid damage to your vehicle, observe the following when using a high-pressure cleaner:

- Keep the key at least 3 m away from the vehicle. Otherwise the tailgate could open unintentionally.
- Maintain a distance of at least 30 cm to the vehicle.

- **Vehicles with decorative foil:** parts of your vehicle are covered with a decorative foil. Maintain a distance of at least 70 cm between the foil-covered parts of the vehicle and the nozzle of the high-pressure cleaner. Move the high-pressure cleaner nozzle around whilst cleaning.
- Observe the information on the correct distance in the equipment manufacturer's operating instructions.
- Do not point the nozzle of the high-pressure cleaner directly at sensitive parts such as tyres, gaps, electrical components, batteries, light sources and ventilation slots.

Washing the vehicle by hand

Observe the legal requirements, e.g. in a number of countries, washing by hand is only permitted in specially designated wash bays.

- ▶ Use a mild cleaning agent, e.g. car shampoo.
- ▶ Wash the vehicle with lukewarm water using a soft car sponge. When doing so, do not expose the vehicle to direct sunlight.
- ▶ Carefully hose the vehicle off with water and dry using a chamois. Take care not to point the water jet directly towards the air inlet.

Notes on paintwork/matt finish paintwork care

Observe the following information:

	Cleaning and care	Avoiding paintwork damage
Paintwork	<ul style="list-style-type: none"> • Insect remains: soak with insect remover and rinse off the treated areas afterwards. • Bird droppings: soak with water and rinse off afterwards. • Coolant, brake fluid, tree resins, oils, fuel and greases: remove by gently rubbing with a cloth soaked in petroleum ether or lighter fluid. • Tar stains: use tar remover. • Wax: use silicone remover. 	<ul style="list-style-type: none"> • Do not attach stickers, films or similar. • Remove dirt immediately, where possible.
Matt finish	<ul style="list-style-type: none"> • Only use care products approved by Mercedes-Benz. 	<ul style="list-style-type: none"> • Do not polish the vehicle and light-alloy wheels. • Only use car washes that correspond to the latest engineering standards. • Do not use car wash programmes with a final hot wax treatment. • Do not use paint cleaners, buffing or polishing products, gloss preservers, e.g. wax. • Always have paintwork repairs carried out at a qualified specialist workshop.

Notes on care of car parts

⚠ WARNING Risk of entrapment if the windscreen wipers are switched on while the windscreen is being cleaned

If the windscreen wipers are set in motion while you are cleaning the windscreen or wiper blades, you can be trapped by the wiper arm.

▶ Always switch off the windscreen wipers and the ignition before cleaning the windscreen or wiper blades.

⚠ WARNING Risk of burns from tailpipes and tailpipe trim

The tailpipe and tailpipe trim can become very hot. If you come into contact with these parts of the vehicle, you could burn yourself.

▶ Always be particularly careful around the tailpipe and the tailpipe trim.
▶ Allow the vehicle parts to cool down before you touch them.

Observe the following information:

	Notes on cleaning and care	Avoiding vehicle damage
Wheels/rims	Use water and acid-free wheel cleaners.	<ul style="list-style-type: none"> • Do not use acidic wheel cleaners to remove brake dust. This could damage wheel bolts and brake components. • To avoid corrosion of the brake discs and brake pads, drive the vehicle for a few minutes after cleaning before parking it. The brake discs and brake pads warm up and dry out.
Windows	Clean the windows on the inside and outside using a damp cloth and cleaning agents recommended by Mercedes-Benz.	Do not use dry cloths or abrasive or solvent-based cleaning agents to clean the inside of windows.

	Notes on cleaning and care	Avoiding vehicle damage
Wiper blades	Fold out the wiper blades and clean them using a damp cloth.	Do not clean the wiper blades too often.
Exterior lighting	Clean the lenses with a wet sponge and mild cleaning agent, e.g. car shampoo.	Only use cleaning agents or cleaning cloths that are suitable for plastic covers.
Sensors	Clean the sensors in the front and rear bumper and in the radiator trim with a soft cloth and car shampoo.	When using a high-pressure cleaner, maintain a minimum distance of 30 cm.
Reversing camera and 360° Camera	<ul style="list-style-type: none"> • Open the camera cover with the multimedia system (→ page 205). • Use clear water and a soft cloth to clean the camera lens. 	Do not use a high-pressure cleaner.
Exhaust pipes	Clean with cleaning agents recommended by Mercedes-Benz, particularly in the winter and after washing the vehicle.	Do not use acidic cleaning agents.
Trailer tow hitch	<ul style="list-style-type: none"> • Remove traces of rust on the ball, e.g. with a wire brush. • Remove dirt with a lint-free cloth. • After cleaning, oil or grease the ball coupling lightly. • Observe the notes on care in the trailer tow hitch manufacturer's operating instructions. 	Do not clean the ball coupling with a high-pressure cleaner or solvent.

Notes on care of the interior

⚠ WARNING Risk of injury from plastic parts breaking off after the use of solvent-based care products

Care and cleaning products containing solvents can cause surfaces in the cockpit to become porous.

When the airbags are deployed, plastic parts may break away.

▶ Do not use any care or cleaning products containing solvents to clean the cockpit.

⚠ WARNING Risk of injury or death from bleached seat belts

Bleaching or dyeing seat belts can severely weaken them.

This can, for example, cause seat belts to tear or fail in an accident.

▶ Never bleach or dye seat belts.

Observe the following information:

	Cleaning and care	Avoiding vehicle damage
Seat belts	Clean with lukewarm and soapy water.	<ul style="list-style-type: none"> Do not use chemical cleaning agents. Do not dry seat belts by heating them to over 80 °C or exposing them to direct sunlight.
Display	Clean the surface carefully with a microfibre cloth and TFT/LCD display care product.	<ul style="list-style-type: none"> Switch off the display and let it cool down. Do not use any other cleaning products.
Plastic trim	<ul style="list-style-type: none"> Clean with a damp microfibre cloth. For heavy soiling: use care product recommended by Mercedes-Benz. 	<ul style="list-style-type: none"> Do not attach stickers, films or similar. Do not allow cosmetics, insect repellent or sun cream to come in contact with the plastic trim.

Cleaning and care		Avoiding vehicle damage
Real wood/trim elements	<ul style="list-style-type: none"> • Clean with a microfibre cloth. • Piano-lacquer black look: clean with a damp cloth and soap solution. • For heavy soiling: use care product recommended by Mercedes-Benz. 	Do not use solvent-based cleaning agents, polishes or waxes.
Roof lining	Clean with a brush or dry shampoo.	
Carpet	Use carpet and textile cleaning agents recommended by Mercedes-Benz.	
Genuine leather seat covers	<ul style="list-style-type: none"> • Clean with a damp cloth and then wipe with a dry cloth. • Leather care: use leather care agents that have been recommended by Mercedes-Benz. 	Do not allow the leather to become too damp. Do not use a microfibre cloth.
DINAMICA seat covers	Clean with a damp cloth.	Do not use a microfibre cloth.
Artificial leather seat covers	Clean with a damp cloth and 1% soapy water.	Do not use a microfibre cloth.
Cloth seat covers	Clean with a damp cloth and 1% soapy water and allow to dry.	

Emergency

Removing the reflective safety jacket

The reflective safety jackets are located in the safety jacket compartments in the driver's and front-passenger door stowage compartments.

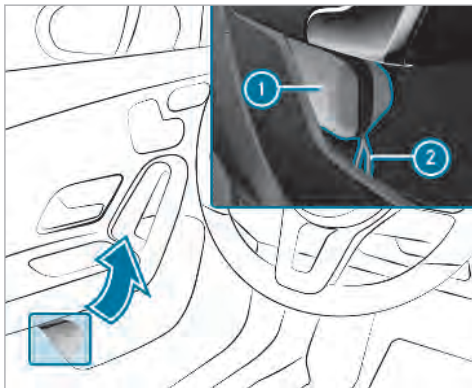

To remove: pull out safety jacket bag ① by loop ②.

▶ Open safety jacket bag ① and pull out the safety jacket.

ⓘ There are also safety jacket compartments in the rear door stowage compartments in which safety jackets can be stowed.

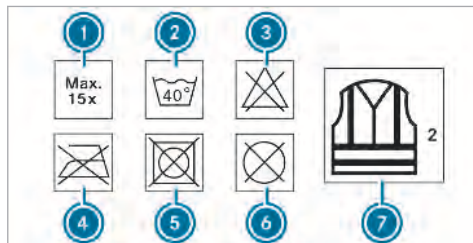

- ① Maximum number of washes
- ② Maximum wash temperature
- ③ Do not bleach
- ④ Do not iron
- ⑤ Do not use a laundry dryer
- ⑥ Do not dry-clean
- ⑦ This is a class 2 jacket

The requirements defined by the legal standard are only fulfilled if the safety jacket is the correct size and is fully closed.

Replace the safety jacket if:

- it is damaged or dirt on the reflective strips can no longer be removed
- the maximum number of washes is exceeded
- the fluorescence of the safety jacket has faded

Warning triangle

Removing the warning triangle

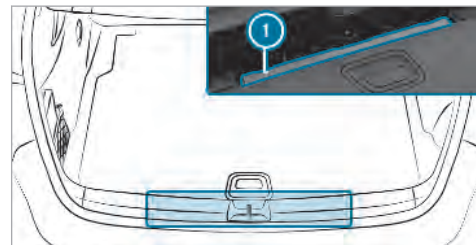

- ▶ Remove ① warning triangle.

Setting up the warning triangle



- ▶ Fold side reflectors ① upwards to form a triangle and attach at the top using press-stud ②.
- ▶ Fold legs ③ down and out to the side.

First-aid kit (soft sided)

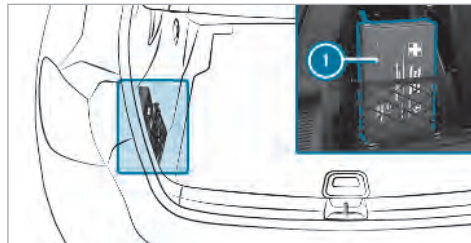

The first-aid kit ① is in the luggage compartment in the left-hand storage net.

- ⓘ Depending on the vehicle's equipment, the first-aid kit is in the recess in the side trim.

Removing the fire extinguisher

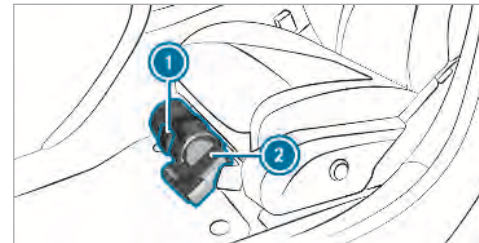

- ▶ **Left-hand-drive vehicle:** Pull tab ① upwards.
- ▶ Remove fire extinguisher ②.

Flat tyre

Notes on flat tyres

⚠ WARNING Risk of accident due to a flat tyre

A flat tyre severely affects the driving characteristics as well as the steering and braking of the vehicle.

Tyres without run-flat characteristics:

- ▶ Do not drive on with a flat tyre.
- ▶ Change the flat tyre immediately with the emergency spare wheel or spare wheel. Alternatively, consult a qualified specialist workshop.

Tyres with run-flat characteristics:

- ▶ Observe the information and warning notes on MOExtended tyres (run-flat tyres).

In the event of a flat tyre, the following options are available depending on your vehicle's equipment:

- **Vehicles with MOExtended tyres:** it is possible to continue the journey for a short period of time. Make sure you observe the notes on MOExtended tyres (run-flat tyres) (→ page 390).
 - **Vehicles with a TIREFIT kit:** you can repair the tyre so that it is possible to continue the journey for a short period of time. To do this, use the TIREFIT kit (→ page 391).
 - **Vehicles with Mercedes me connect:** you can make a call for breakdown assistance via the overhead control panel in the case of a breakdown (→ page 346).
 - **All vehicles:** change the wheel (→ page 422).
- i** The emergency spare wheel is only available in certain countries.

Notes on MOExtended tyres (run-flat tyres)

⚠ WARNING Risk of accident when driving in limp-home mode

When driving in emergency mode the handling characteristics are impaired. e.g. when cornering, when accelerating strongly and when braking.

- ▶ Do not exceed the specified maximum speed.
- ▶ Avoid any abrupt steering and driving manoeuvres as well as driving over obstacles (kerbs, pot holes, off-road). This applies, in particular, to a loaded vehicle.
- ▶ Stop driving in the emergency mode if you notice:
 - banging noise
 - vehicle vibration
 - smoke which smells like rubber
 - continuous ESP[®] intervention
 - cracks in tyre side walls

- ▶ After driving in emergency mode have the rims checked by a qualified specialist workshop with regard to their further use.
- ▶ The defective tyre must be replaced in every case.

With MOExtended tyres (run-flat tyres), you can continue to drive your vehicle even if there is a total loss of pressure in one or more tyres. However, the tyre affected must not show any clearly visible damage.

You can recognise MOExtended tyres by the MOExtended marking which appears on the side wall of the tyre.

Vehicles with tyre pressure loss warning system: MOExtended tyres may only be used in conjunction with an activated tyre pressure loss warning system.

Vehicles with tyre pressure monitoring system: MOExtended tyres may only be used in conjunction with an activated tyre pressure monitoring system.

If a pressure loss warning message appears in the multifunction display:

- Check the tyre for damage.
- If driving on, observe the following notes.

Driving distance possible in limp-home mode after the pressure loss warning:

Load condition	Driving distance possible in limp-home mode
Partially laden	80 km
Fully laden	30 km

- The driving distance possible in limp-home mode may vary depending on the driving style.
- Maximum permissible speed 80 km/h.

If a tyre has gone flat and cannot be replaced with an MOExtended tyre, you can use a standard tyre as a temporary measure.

Using the TIREFIT kit

Requirements

Have the following tools readily available:

- tyre sealant bottle
- TIREFIT sticker
- tyre inflation compressor

You can use TIREFIT tyre sealant to seal perforation damage of up to 4 mm, particularly those in the tyre contact surface. You can use TIREFIT in outside temperatures down to -20 °C.

⚠ WARNING Risk of accident when using tyre sealant

In the following situations, the tyre sealant is unable to provide sufficient breakdown assistance, as it is unable to seal the tyre properly:

- there are cuts or punctures in the tyre larger than those previously mentioned.
- the wheel rim is damaged.

- you have driven at very low tyre pressures or on a flat tyre.
- ▶ Do not drive on.
 - ▶ Consult a qualified specialist workshop.

⚠ WARNING Risk of injury and poisoning from tyre sealant

Tyre sealant is hazardous to health and causes irritation. Do not allow it to come into contact with your skin, eyes or clothing, and do not swallow it. Do not inhale any vapours. Keep the tyre sealant away from children.

Observe the following if you come into contact with the tyre sealant:

- ▶ Rinse off the tyre sealant from your skin using water immediately.
- ▶ If tyre sealant gets into your eyes, thoroughly rinse them using clean water immediately.
- ▶ If tyre sealant has been swallowed, thoroughly rinse out your mouth immediately and drink plenty of water. Do not

induce vomiting and seek medical attention immediately.

- ▶ Change out of clothing which has come into contact with tyre sealant immediately.
- ▶ If an allergic reaction occurs, seek medical attention immediately.

! **NOTE** Overheating due to the tyre inflation compressor running too long

- ▶ Do not run the tyre inflation compressor for longer than ten minutes without interruption.

Comply with the manufacturer's safety notes on the sticker on the tyre inflation compressor.

Have the tyre sealant bottle replaced in a qualified specialist workshop every five years.

- ▶ Do not remove any foreign objects which have entered the tyre.

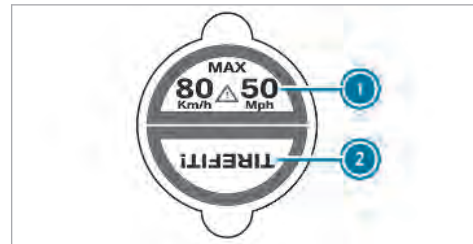

- ▶ Affix part ① of the TIREFIT sticker to the instrument cluster within the driver's field of vision.
- ▶ Affix part ② of the TIREFIT sticker near the valve on the wheel with the defective tyre.



- ▶ Pull plug ④ with the cable and hose ⑤ out of the tyre inflation compressor housing.
- ▶ Push the plug of hose ⑤ into flange ⑥ of tyre sealant bottle ① until the plug engages.
- ▶ Place tyre sealant bottle ① head downwards into recess ② of the tyre inflation compressor.



- ▶ Remove the valve cap from valve ⑦ on the faulty tyre.
- ▶ Screw filling hose ⑧ onto valve ⑦.
- ▶ Insert plug ④ into a 12 V socket in your vehicle.
- ▶ Switch the ignition on.
- ▶ Press on and off switch ③ on the tyre inflation compressor. The tyre inflation compressor is switched on. The tyre is inflated. First, tyre sealant is pumped into the tyre. The pressure may briefly rise to approximately 500 kPa (5 bar/73 psi).

Do not switch off the tyre inflation compressor during this phase.

- ▶ Let the tyre inflation compressor run for a maximum of ten minutes. The tyre should then have attained a tyre pressure of at least 200 kPa (2.0 bar/29 psi).

If tyre sealant leaks out, make sure you clean the affected areas as quickly as possible. It is preferable to use clean water.

If you get tyre sealant on your clothing, have it cleaned as soon as possible with perchloroethylene.

If, after ten minutes, a tyre pressure of 200 kPa (2.0 bar/29 psi) has not been achieved:

- ▶ switch off the tyre inflation compressor.
- ▶ unscrew the filling hose from the valve of the defective tyre.

Please note that tyre sealant may leak out when unscrewing the filling hose.

- ▶ very slowly drive forwards or reverse approximately 10 m.
- ▶ Pump up the tyre again.
After a maximum of ten minutes the tyre pressure must be at least 200 kPa (2.0 bar/ 29 psi).

⚠ WARNING Risk of accident due to the specified tyre pressure not being achieved

If the specified tyre pressure is not achieved after the specified time, the tyre is too badly damaged. The tyre sealant cannot repair the tyre in this instance.

Damaged tyres and a tyre pressure that is too low can significantly impair braking and handling characteristics.

- ▶ Do not drive on.
- ▶ Consult a qualified specialist workshop.

If, after ten minutes, a tyre pressure of 200 kPa (2.0 bar/29 psi) has been achieved:

- ▶ switch off the tyre inflation compressor.

- ▶ unscrew the filling hose from the valve of the defective tyre.

⚠ WARNING Risk of accident from driving with sealed tyres

A tyre temporarily sealed with tyre sealant impairs handling characteristics and is not suitable for higher speeds.

- ▶ Adapt your driving style accordingly and drive carefully.
- ▶ Do not exceed the specified maximum speed with a tyre that has been sealed using tyre sealant.

- ▶ Observe the maximum permissible speed for a tyre sealed with tyre sealant 80 km/h.
- ▶ Fasten the upper section of the TIREFIT sticker to the instrument cluster where it will be easily seen by the driver.

! NOTE Staining from leaking tyre sealant

After use, excess tyre sealant may leak out from the filling hose.

- ▶ Therefore, place the filling hose in the plastic bag that contained the TIREFIT kit.

🌿 ENVIRONMENTAL NOTE Environmental pollution caused by environmentally irresponsible disposal

Tyre sealant contains pollutants.

- ▶ Have the tyre sealant bottle disposed of professionally, e.g. at a Mercedes-Benz Service Centre.

- ▶ Store the tyre sealant bottle, the tyre inflation compressor and the warning triangle.
- ▶ **Pull away immediately.**
- ▶ Stop driving after approximately ten minutes and check the tyre pressure using the tyre inflation compressor.
The tyre pressure must now be at least 130 kPa (1.3 bar/ 19 psi).

⚠ WARNING Risk of accident due to the specified tyre pressure not being achieved

If the specified tyre pressure is not achieved after a brief drive, the tyre is too badly damaged. The tyre sealant cannot repair the tyre in this instance.

Damaged tyres and a tyre pressure that is too low can significantly impair braking and handling characteristics.

- ▶ Do not drive on.
- ▶ Consult a qualified specialist workshop.

Countries that have Mercedes-Benz

Service24h: a sticker with the telephone number can also be found in your vehicle, e.g. on the B-pillar on the driver's side.

- ▶ Correct the tyre pressure if it is still at least 130 kPa (1.3 bar/19 psi). See the tyre pressure table on the fuel filler flap for values.
- ▶ **To increase the tyre pressure:** switch on the tyre inflation compressor.

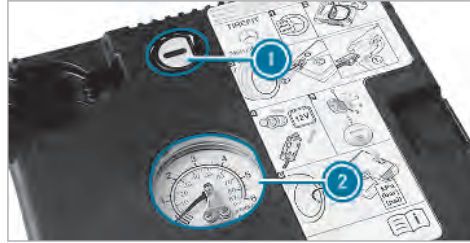

- ▶ **To reduce the tyre pressure:** press pressure release button ① next to manometer ②.
- ▶ When the tyre pressure is correct, unscrew the filling hose from the valve of the sealed tyre.
- ▶ Screw the valve cap onto the tyre valve of the sealed tyre.
- ▶ Pull the tyre sealant bottle out of the tyre inflation compressor. The filling hose stays on the tyre sealant bottle.

- ▶ Drive to the nearest qualified specialist workshop and have the tyre, tyre sealant bottle and filling hose replaced there.

Battery (vehicle)

Notes on the 12 V battery

⚠ WARNING Risk of an accident due to work carried out incorrectly on the battery

Work carried out incorrectly on the battery can, for example, lead to a short circuit. This can lead to function restrictions in safety-relevant systems, e.g. the lighting system, ABS (anti-lock braking system) or ESP® (Electronic Stability Program). The operating safety of your vehicle may be restricted.

You could lose control of the vehicle in the following situations:

- when braking
- in the event of abrupt steering manoeuvres and/or when the vehicle's speed is not adapted to the road conditions

- ▶ In the event of a short circuit or a similar incident, contact a qualified specialist workshop immediately.
- ▶ Do not continue driving.
- ▶ Always have work on the battery carried out at a qualified specialist workshop.

- Further information on ABS (→ page 169)
- Further information on ESP® (→ page 170)

For safety reasons, Mercedes-Benz recommends that you only use batteries which have been tested and approved for your vehicle by Mercedes-Benz. These batteries provide increased impact protection to prevent vehicle occupants from suffering acid burns should the battery be damaged in the event of an accident.

⚠ WARNING Risk of explosion due to electrostatic charge

Electrostatic charge can cause sparks which may ignite the highly flammable gas mixture in the battery.

- ▶ To discharge any electrostatic charge that may have built up, touch the metal vehicle body before handling the battery.

The highly flammable gas mixture is created while the battery is charging and during starting assistance.

⚠ WARNING Danger of chemical burns from the battery acid

Battery acid is caustic.

- ▶ Avoid contact with the skin, eyes or clothing.
- ▶ Do not lean over the battery.
- ▶ Do not inhale battery gases.
- ▶ Keep children away from the battery.
- ▶ Immediately rinse battery acid off thoroughly with plenty of clean water and seek medical attention immediately.

🌿 ENVIRONMENTAL NOTE Environmental damage due to improper disposal of batteries



Batteries contain pollutants. It is illegal to dispose of them with the household rubbish.



Dispose of batteries in an environmentally responsible manner. Take discharged batteries to a qualified specialist workshop or to a collection point for used batteries.

If you have to connect the 12 volt battery, contact a qualified specialist workshop.

Comply with safety notes and take protective measures when handling batteries.



Risk of explosion.



Fire, naked flames and smoking are prohibited when handling the battery. Avoid creating sparks.



Electrolyte or battery acid is corrosive. Avoid contact with the skin, eyes or clothing. Wear suitable protective clothing, in particular gloves, an apron and a face mask. Immediately rinse electrolyte or acid splashes off with clean water. Consult a doctor if necessary.



Wear safety glasses.



Keep children away.



Observe this Owner's Manual.

If you do not intend to use the vehicle over an extended period of time:

- Activate standby mode, or
- Connect the battery to a battery charger approved by Mercedes-Benz, or
- Consult a qualified specialist workshop to disconnect the battery

Starting assistance and charging the 12 V battery

- ▶ When charging the battery and during starting assistance, always use the jump-start connection point in the engine compartment.

! **NOTE** Damaging the battery through overvoltage

When using a battery charger without a maximum charging voltage, the battery or the vehicle electronics may be damaged.

- ▶ Only use battery chargers with a maximum charging voltage of 14.8 V.

! **WARNING** Risk of explosion from hydrogen gas igniting

A battery generates hydrogen gas during the charging process. If there is a short circuit or sparks start to form, there is a danger of the hydrogen gas igniting.

- ▶ Make sure that the positive terminal of the connected battery does not come into contact with vehicle parts.
- ▶ Never place metal objects or tools on a battery.
- ▶ When connecting and disconnecting the battery, you must observe the described order for the battery clamps.
- ▶ When giving starting assistance, always make sure that you only connect battery terminals with identical polarity.
- ▶ During starting assistance, you must observe the described order for con-

necting and disconnecting the jump lead.

- ▶ Do not connect or disconnect the battery clamps while the engine is running.

⚠ WARNING Risk of explosion during charging process and starting assistance

During the charging process and starting assistance, the battery may release an explosive gas mixture.

- ▶ Avoid fire, naked flames, creating sparks and smoking.
- ▶ Make sure that there is sufficient ventilation during the charging process and during starting assistance.
- ▶ Do not lean over a battery.

If the indicator/warning lamps in the instrument cluster do not light up at low temperatures, it is very likely that the discharged battery has frozen.

⚠ WARNING Risk of explosion from a frozen battery

A discharged battery may freeze at temperatures slightly above or below freezing point.

During starting assistance or battery charging, battery gas may be released.

- ▶ Always thaw a frozen battery out first before charging it or performing starting assistance.

The service life of a battery that has been thawed may be dramatically shortened.

It is recommended that you have a thawed battery checked at a qualified specialist workshop.

! NOTE Damage caused by numerous or extended attempts to start the engine

Numerous or extended attempts to start the engine may damage the catalytic converter due to non-combusted fuel.

- ▶ Avoid numerous and extended attempts to start the engine.

Observe the following points during starting assistance and when charging the battery:

- Only use undamaged jump lead/charging cables with a sufficient cross-section and insulated terminal clamps.
- Non-insulated parts of the terminal clamps must not come into contact with other metal parts while the jump lead/charging cable is connected to the battery/jump-start connection point.
- The jump lead/charging cable must not come into contact with any parts which may move when the engine is running.
- Always make sure that neither you nor the battery is electrostatically charged.
- Keep away from fire and naked flames.
- Do not lean over the battery.
- **When charging:** only use battery chargers tested and approved by Mercedes-Benz and read the battery charger's operating instructions before charging the battery.

Observe the additional following points during starting assistance:

- Starting assistance may only be provided using batteries with a nominal voltage of 12 V.
 - The vehicles must not touch.
 - **Petrol engine:** only accept starting assistance if the engine and exhaust system are cold.
- ▶ Secure the vehicle by applying the electric parking brake.
 - ▶ **Automatic transmission:** shift the transmission to position **P**.
 - ▶ Make sure that the ignition and all electrical consumers are switched off.
 - ▶ Open the bonnet.

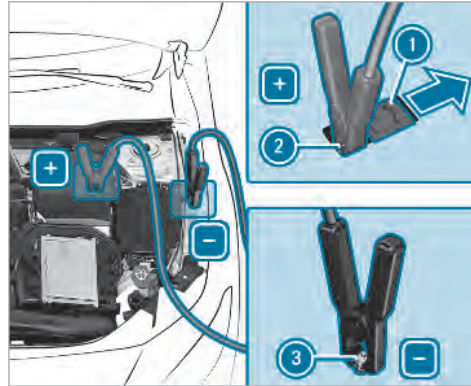

- ▶ Slide cover ① of positive clamp ② on the jump-starting connection point ② in the direction of the arrow.
- ▶ Connect positive clamp ② on your vehicle to positive pole of the donor battery using the jump lead/charging cable. Always begin with positive clamp ② on your own vehicle first.

- ▶ **During the starting assistance procedure:** start the engine of the donor vehicle and run at idle speed.
- ▶ Connect the negative pole of the donor battery and earth point ③ of your own vehicle by using the jump lead/charging cable. Begin with the donor battery first.
- ▶ **During starting assistance:** start the engine of your own vehicle.
- ▶ **During the charging process:** start the charging process.
- ▶ **During starting assistance:** let the engines run for several minutes.
- ▶ **During starting assistance:** before disconnecting the jump lead, switch on an electrical consumer in your own vehicle, e.g. the rear window heater or lighting.

When the starting assistance/charging process is complete:

- ▶ First, remove the jump lead/charging cable from earth point ③ and negative pole of the donor battery, then from positive clamp ② and positive pole of the donor battery. Begin

each time with the contacts on your own vehicle first.

- ▶ After removing the jump lead/charging cable, close cover ① of positive clamp ②.

Further information can be obtained at a qualified specialist workshop.

Replacing the 12 V battery

- ▶ Observe the notes on the 12 V battery (→ page 395).

Mercedes-Benz recommends that you have the 12 V battery replaced at a qualified specialist workshop, e.g. at a Mercedes-Benz Service Centre.

Observe the following notes if you want to replace the battery yourself:

- Always replace a faulty battery with a battery which meets the specific vehicle requirements.

- Carry over detachable parts, such as vent hoses, elbow fittings or terminal covers from the battery being replaced.
- Make sure that the vent hose is always connected to the original opening on the side of the battery.

Fit any existing or supplied cell caps.

Otherwise, gases or battery acid could escape.

- Make sure that detachable parts are reconnected in the same way.

Tow-starting or towing away

Permitted towing methods



Mercedes-Benz recommends transporting your vehicle in the case of a breakdown, rather than towing it away.

For towing, use a tow rope or tow bar with both axles on the ground. Do not use tow bar systems.

! **NOTE** Damage to the vehicle due to towing away incorrectly

- ▶ Observe the instructions and notes on towing away.

Permitted towing methods

Vehicle equipment/towing method	 Both axes on the ground	 Front axle raised	 Rear axle raised
Vehicles with automatic transmission	Yes, maximum 50 km at 50 km/h	Yes, maximum 50 km at 50 km/h	Yes, maximum 50 km at 50 km/h

Towing with a raised axle: towing should be performed by a towing company.

Towing the vehicle with both axes on the ground

- ▶ Observe the notes on the permitted towing methods (→ page 400) (→ page 401).
- ▶ Make sure that the battery is connected and charged.

When the battery is discharged:

- the engine cannot be started.

- the electric parking brake cannot be released or applied.
- **vehicles with automatic transmission:** the automatic transmission cannot be shifted to position **N** or **P**.

i **vehicles with automatic transmission:** if the automatic transmission cannot be shifted to position **N**, or the multifunction display in the instrument cluster does not show anything, have the vehicle transported away (→ page 403). A towing vehicle with lifting equipment is required for vehicle transportation.

! **NOTE** Damage due to towing away at excessively high speeds or over long distances

The drivetrain could be damaged when towing at excessively high speeds or over long distances.

- ▶ A towing speed of 50 km/h must not be exceeded.
- ▶ A towing distance of 50 km must not be exceeded.

⚠ WARNING Risk of accident when towing a vehicle which is too heavy

If the vehicle being tow-started or towed away is heavier than the permissible gross mass, the following situations can occur:

- the towing eye may become detached.
- the car/trailer combination may swerve or even overturn.

▶ If another vehicle is tow-started or towed away, its weight must not exceed the permissible gross mass of your own vehicle.

If a vehicle must be tow started or towed away, its permissible gross mass must not exceed the permissible gross mass of the towing vehicle.

- ▶ Information on the permissible gross mass of the vehicle can be found on the vehicle identification plate .
- ▶ **Vehicles with automatic transmission:** do not open the driver's door or front passenger door, otherwise the automatic transmission automatically shifts to position **P**.

- ▶ Fit the towing eye (→ page 404).
- ▶ Attach the tow bar.

! **NOTE** Damage due to incorrect connection

- ▶ Only connect the tow rope or tow bar to the towing eyes.

- ▶ Deactivate the automatic locking mechanism (→ page 72).
- ▶ Do not activate the HOLD function.
- ▶ Deactivate the tow-away protection (→ page 84).
- ▶ Deactivate Active Brake Assist (→ page 178).
- ▶ **Vehicles with automatic transmission:** shift the automatic transmission to position **N**.
- ▶ Release the electric parking brake.

⚠ WARNING Risk of accident due to limited safety-related functions during the towing process

Safety-related functions are limited or no longer available in the following situations:

- the ignition is switched off.
- the brake system or power steering system is malfunctioning.
- the energy supply or the on-board electrical system is malfunctioning.

When your vehicle is then towed away, significantly more effort may be required to steer and brake than is normally required.

- ▶ Use a tow bar.
- ▶ Make sure that the steering wheel can move freely, before towing the vehicle away.

! **NOTE** Damage due to excessive tractive power

If you pull away sharply, the tractive power may be too high and the vehicles could be damaged.

- ▶ Pull away slowly and smoothly.

Loading the vehicle for transport

- ▶ Observe the notes on towing away (→ page 401).
- ▶ Connect the tow bar to the towing eye to load the vehicle.
- i** You can also attach the tow bar to the trailer hitch.
- ▶ **Vehicles with automatic transmission:** shift the automatic transmission to position **N**.
- i** **Vehicles with automatic transmission:** the automatic transmission may be locked in position **P** in the event of damage to the electrical system. To shift to **N**, provide the

on-board electrical system with power (→ page 397).

- ▶ Load the vehicle onto the transporter.
- ▶ **Vehicles with automatic transmission:** shift the automatic transmission to position **P**.
- ▶ Use the electric parking brake to secure the vehicle and prevent it from rolling away.
- ▶ Only secure the vehicle by the wheels.

4MATIC vehicles/vehicles with automatic transmission

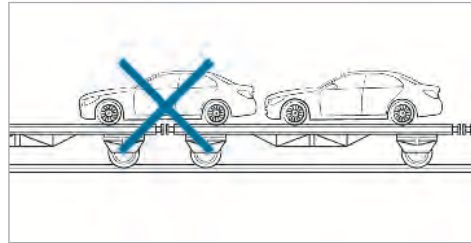

- ▶ Make sure that the front and rear axles come to rest on the same transportation vehicle.

! **NOTE** Damage to the drivetrain due to incorrect positioning

- ▶ Do not position the vehicle above the connection point of the transport vehicle.

Towing eye storage location

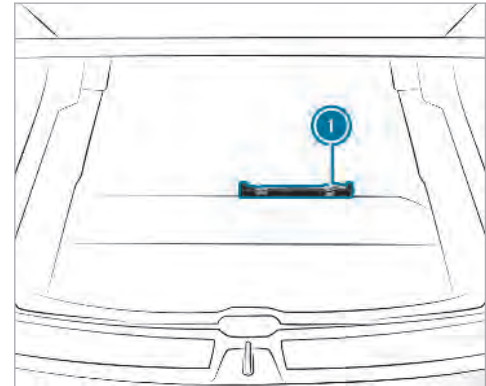

Towing eye ① is under the load compartment floor.

Installing the towing eye

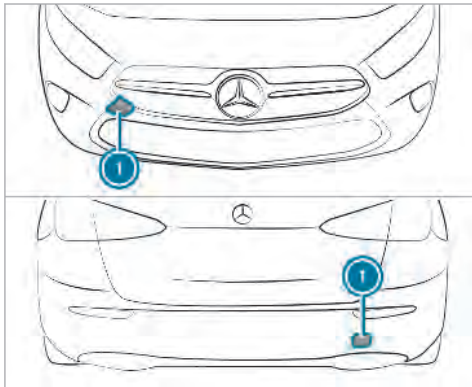

- ▶ Press the mark on cover ① inwards and remove.
- ▶ Screw in the towing eye clockwise as far as it will go and tighten.

Vehicles with a trailer hitch: vehicles with a trailer hitch do not have a rear bracket for the towing eye. Fasten the tow bar to the trailer hitch.

- ① Make sure that cover ① engages in the bumper when you remove the towing eye.

! **NOTE** Damage due to incorrect use of the towing eye

When a towing eye is used to recover a vehicle, the vehicle may be damaged in the process.

- ▶ Only use the towing eye to tow away or tow start the vehicle.

Tow-starting the vehicle (emergency engine starting)

Vehicles with automatic transmission

! **NOTE** Damage to the automatic transmission due to tow-starting

The automatic transmission may be damaged in the process of tow-starting vehicles with automatic transmission.

- ▶ Vehicles with automatic transmission must not be tow-started.

- ▶ Vehicles with automatic transmission must not be tow-started.

Electrical fuses

Notes on electrical fuses

! **WARNING** Risk of accident and injury due to overloaded lines

If you manipulate or bridge a faulty fuse or if you replace it with a fuse with a higher

amperage, the electric line could be overloaded.

This could result in a fire.

- ▶ Always replace faulty fuses with specified new fuses containing the correct amperage.

! **NOTE** Damage caused by incorrect fuses

Incorrect fuses may cause damage to electrical components or systems.

- ▶ Only use Mercedes-Benz approved fuses with the correct fuse rating.

Blown fuses must be replaced with fuses of the same rating, which you can recognise by the colour and fuse rating. Only use fuses marked with an "S". The fuse ratings are listed in the fuse assignment diagram.

Fuse assignment diagram: on the fuse box in the engine compartment (→ page 405).

! **NOTE** Damage or malfunctions caused by moisture

Moisture may cause damage to the electrical system or cause it to malfunction.

- ▶ When the fuse box is open, make sure that no moisture can enter the fuse box.
- ▶ When closing the fuse box, make sure that the seal of the lid is positioned correctly on the fuse box.

If the newly inserted fuse also blows, have the cause traced and rectified at a qualified specialist workshop, e.g. a Mercedes-Benz Service Centre.

Ensure the following before replacing a fuse:

- The vehicle is secured against rolling away.
- All electrical consumers are switched off.
- The ignition is switched off.

The electrical fuses are located in various fuse boxes:

- Fuse box on the driver's side of the engine compartment (→ page 405)
- Fuse box in the front-passenger footwell (→ page 406)
- Fuse box in the central load compartment (→ page 407)

Fuse box in the engine compartment

Observe the notes on electrical fuses (→ page 404).

Have the following tools readily available:

- A dry cloth
- A screwdriver

Opening

⚠ WARNING Risk of injury from using the windscreen wipers while the engine bonnet is open

When the engine bonnet is open, and the windscreen wipers are set in motion, you can be trapped by the wiper linkage.

▶ Always switch off the windscreen wipers and ignition before opening the engine bonnet.

▶ Open the bonnet.

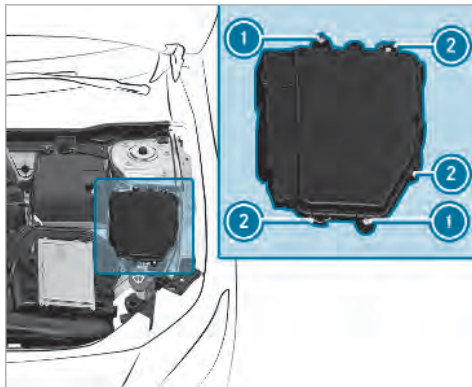

- ▶ Remove any existing moisture from the fuse box using a dry cloth.
- ▶ Loosen screws ①.
- ▶ Press clamps ② and lift the fuse box lid up and out.

The fuse assignment diagram is in a recess on the side of the fuse box.

Closing

- ▶ Check whether the seal is positioned correctly in the lid.
- ▶ Place the lid on the fuse box.
- ▶ Make sure that clamps ② engage.
- ▶ Tighten screws ①.
- ▶ Close the bonnet.

Fuse box in the front-passenger footwell

Observe the notes on electrical fuses (→ page 404).

Opening

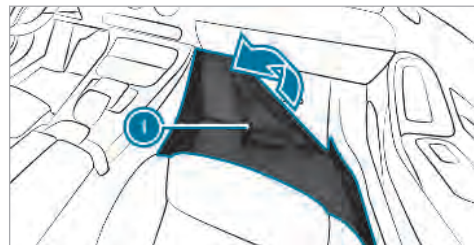

- ▶ Lift carpet ① in the direction of the arrow.

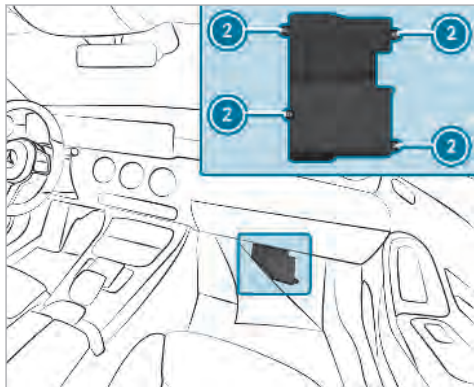

- ▶ Loosen screws ② and remove fuse box lid from the top.

Closing

- ▶ Place the lid on the fuse box.
- ▶ Tighten screws ②.
- ▶ Fold back carpet ①.

Fuse box in the load compartment

Observe the notes on electrical fuses (→ page 404).

- ▶ Open the luggage compartment floor .

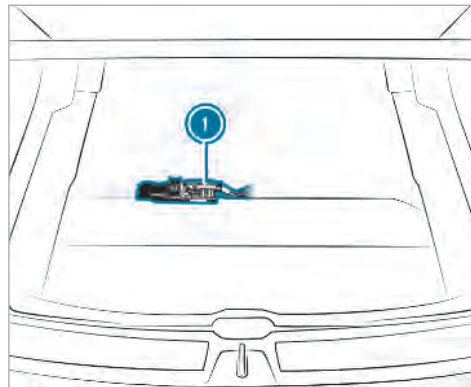

Fuse box ① is located in the centre underneath the luggage compartment floor.

Notes on noise or unusual handling characteristics

While driving, pay attention to vibrations, noises and unusual handling characteristics, e.g. pulling to one side. This may indicate that the wheels or tyres are damaged. If you suspect that a tyre is defective, reduce your speed immediately. Stop the vehicle as soon as possible to check the wheels and tyres for damage. Hidden tyre damage could also be causing the unusual handling characteristics. If you find no signs of damage, have the tyres and wheels checked at a qualified specialist workshop.

Regular checking of wheels and tyres

⚠ WARNING Risk of accident from damaged tyres

Damaged tyres can cause tyre pressure loss. As a result, you could lose control of your vehicle.

▶ Check the tyres regularly for signs of damage and replace any damaged tyres immediately.

⚠ WARNING Risk of aquaplaning due to insufficient tyre tread

Insufficient tyre tread will result in reduced tyre grip. The tyre tread is no longer able to dissipate water.

This means that in heavy rain or slush the risk of aquaplaning is increased, in particular where speed is not adapted to suit the conditions.

If the tyre pressure is too high or too low, tyres may exhibit different levels of wear at different locations on the tyre tread.

▶ Thus, you should regularly check the tread depth and the condition of the tread across the entire width of all tyres.

Minimum tread depth for:

- Summer tyres: 3 mm
- M+S tyres: 4 mm

▶ For safety reasons, replace the tyres before the legally prescribed limit for the minimum tread depth is reached.

Carry out the following checks on all wheels regularly, at least once a month or as required, e.g. prior to a long journey or driving off-road:

- Check the tyre pressure (→ page 409).
- Visual inspection of wheels and tyres for damage.
- Check the valve caps.

The valves must be protected against moisture and dirt by the valve caps approved especially for your vehicle by Mercedes-Benz.

- Visual check of the tyre tread depth and the tyre tread condition across the entire width. The minimum tread depth for summer tyres is 3 mm and for winter tyres 4 mm.

Notes on snow chains

⚠ WARNING Risk of accident due to incorrect snow chain fitting

If you fit snow chains to the rear wheels, the snow chains may grind against the vehicle body or chassis components.

This could cause damage to the vehicle or the tyres.

- ▶ Never fit snow chains to the rear wheels.
- ▶ Always fit snow chains to the front wheels in pairs.

! NOTE Damage to the wheel trim from fitted snow chains

If snow chains are fitted to steel wheels, the wheel trims can be damaged.

- ▶ Remove the wheel trims of steel wheels before fitting snow chains.

- Snow chains are only permissible for certain wheel/tyre combinations. You can obtain

information about this from a Mercedes-Benz Service Centre.

- For safety reasons, only use snow chains that have been specifically approved for your vehicle by Mercedes-Benz, or snow chains with the same quality standard.
- If snow chains are fitted, the maximum permissible speed is 50 km/h.
- **Vehicles with Active Parking Assist:** do not use Active Parking Assist when snow chains are fitted.
- ① You can permanently limit the maximum vehicle speed for driving with winter tyres (→ page 182).
- ① You can deactivate ESP® to pull away (→ page 172). This allows the wheels to spin, achieving an increased driving force.

Tyre pressure

Notes on tyre pressure

⚠ WARNING Risk of accident due to insufficient or excessive tyre pressure

Underinflated or overinflated tyres pose the following risks:

- The tyres may burst, especially as the load and vehicle speed increase.
 - The tyres may wear excessively and/or unevenly, which may greatly impair tyre traction.
 - The driving characteristics, as well as steering and braking, may be greatly impaired.
- ▶ Comply with the recommended tyre pressure and check the tyre pressure of all tyres including the spare wheel regularly:
- at least once a month
 - when the load changes

- before embarking on a longer journey
 - if operating conditions change, e.g. off-road driving
- ▶ Adjust the tyre pressure as necessary.

Driving with tyre pressure that is too high or too low can:

- Shorten the service life of the tyres.
- Cause increased tyre damage.
- Adversely affect driving characteristics and thus driving safety, e.g. due to aquaplaning.

⚠ WARNING Risk of accident from repeated tyre pressure drop

If the tyre pressure drops repeatedly, the wheel, valve or tyre may be damaged.

Insufficient tyre pressure can cause the tyres to burst.

- ▶ Inspect the tyre for signs of foreign objects.

- ▶ Check whether the wheel or valve has a leak.
- ▶ If you are unable to rectify the damage, contact a qualified specialist workshop.

Information on the recommended tyre pressure for the vehicle's factory-fitted tyres can be found on the tyre pressure table on the inside of the fuel filler flap (→ page 410).

Use a suitable pressure gauge to check the tyre pressure. The outer appearance of a tyre does not permit any reliable conclusion about the tyre pressure.

Vehicles with a tyre pressure monitoring system: you can also check the tyre pressure using the on-board computer.

Only correct tyre pressures when the tyres are cold. Conditions for cold tyres:

- The vehicle has been parked with the tyres out of direct sunlight for at least three hours.
- The vehicle has travelled less than 1.6 km.

A rise in the tyre temperature of 10 °C increases the tyre pressure by approx. 10 kPa (0.1 bar/

1.5 psi). Take this into account when checking the tyre pressure of warm tyres.

Trailer operation notes

Always inflate the rear axle tyres to the recommended tyre pressures on the tyre pressure table for increased load.

Tyre pressure table

The tyre pressure table is on the inside of the fuel filler flap.

		kPa		psi	
		Front	Rear	Front	Rear
Empty	Icon: 2 people				
	Icon: 2 people + luggage				
Partially laden	Icon: 4 people				
	Icon: 4 people + luggage				
Fully laden	Icon: 6 people				
	Icon: 6 people + luggage				

A 213 584 37 03 1234567

The tyre pressure table shows the recommended tyre pressure for all tyres approved for this vehicle. The recommended tyre pressures apply for cold tyres under various operating conditions, i.e. loading and/or speed of the vehicle.

If one or more tyre sizes precede a tyre pressure, the tyre pressure information following is only valid for those tyre sizes.

If the preceding tyre sizes are complemented by the symbol, the tyre pressure information following shows alternative tyre pressures. These tyre pressures may improve your vehicle's ride comfort. Fuel consumption may then increase slightly.

The load conditions "partially laden" and "fully laden" are defined in the table for different numbers of passengers and amounts of luggage. The actual number of seats may differ from this.

Be sure to also observe the following further related subjects:

- Notes on tyre pressure (→ page 409)

Tyre pressure monitoring system

Function of the tyre pressure monitoring system

The system checks the tyre pressure and the tyre temperature of the tyres fitted to the vehicle by means of a tyre pressure sensor.

New tyre pressure sensors, e.g. in winter tyres, are automatically taught-in the first time they are driven.

The tyre pressure and the tyre temperature appear in the multifunction display (→ page 231).

If there is a substantial pressure loss or if the tyre temperature is excessive, a warning will be given:

- Via display messages (→ page 477).
- Via the warning lamp in the instrument cluster (→ page 511).

It is the driver's responsibility to set the tyre pressure to the recommended cold tyre pressure suitable for the operating situation. Set the tyre pressure for cold tyres using a tyre pressure gauge. Note that the correct tyre pressure for the current operating situation must first be taught-in to the tyre pressure monitoring system.

In most cases, the tyre pressure monitoring system will automatically update the new reference values after you have changed the tyre pressure. You can, however, also update the reference values by restarting the tyre pressure monitoring system manually (→ page 412).

System limitations

The system may be impaired or may not function in the following situations:

- If the tyre pressure is set incorrectly.
- If there is a sudden pressure loss caused, for example, by a foreign object penetrating the tyre.
- If there is a malfunction caused by another radio signal source.

Make sure to observe the following further related subject:

- Notes on tyre pressure (→ page 409)

Checking the tyre pressure with the tyre pressure monitoring system

Requirement:

- the ignition is switched on.

On-board computer:

↪ Service ▶ Tyres

One of the following displays appears:

- Current tyre pressure and tyre temperature of the individual wheels:

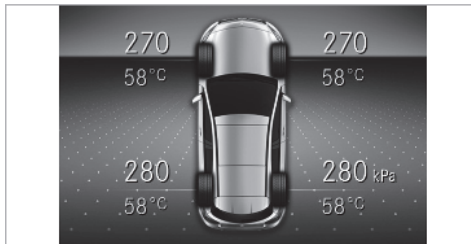

- Tyre pressures will be displayed after a few minutes of driving
- Tyre pressure monitor active: the teach-in process of the system is not yet complete. The tyre pressures are already being monitored.

▶ Compare the tyre pressure with the recommended tyre pressure for the current operating condition (→ page 410). Observe the notes on tyre temperature (→ page 409).

ⓘ The values displayed in the multifunction display may deviate from those of the tyre pressure gauge as they refer to sea level. At high altitudes, the tyre pressure values indicated

by pressure gauges are higher than those shown by the on-board computer. In this case, do not reduce the tyre pressure.

Make sure to observe the following further related subject:

- Notes on tyre pressure (→ page 409)

Restarting the tyre pressure monitoring system

Requirements:

- The recommended tyre pressure is correctly set for the respective operating condition on each of the four wheels (→ page 409).

Restart the tyre pressure monitoring system in the following situations:

- The tyre pressure has changed.
- The wheels or tyres have been changed or newly fitted.

On-board computer:

↪ Service ▶ Tyres

▶ Swipe downwards on Touch Control on the left-hand side of the steering wheel. The **Use current pressures as new reference values?** message is shown in the multifunction display.

▶ To begin restart, press Touch Control on the left-hand side of the steering wheel. The **OK** message is shown in the multifunction display.

Current warning messages are deleted and the  yellow warning lamp goes out.

After you have driven for a few minutes, the system checks whether the current tyre pressures are within the specified range. The current tyre pressures are then accepted as reference values and monitored.

Make sure to observe the following further related subject:

- Notes on tyre pressure (→ page 409)

Radio-equipment approval of the tyre pressure monitoring system



Radio equipment approval numbers



Country	Radio equipment approval number
Abu Dhabi	Huf Electronics Bretten GmbH Model: TSSRE4A Model: TSSSG4G6 TRA Registered No: ERXXXXX/XX Dealer No: DAXXXXXXX/XX
Australia	



Country	Radio equipment approval number
Brazil	 MODELO: TSSRE4A ANATEL: XXXX-XX-XXXX Este equipamento opera em caráter secundário, isto é, não tem direito à proteção contra interferência prejudicial, mesmo de estações do mesmo tipo e não pode causar interferência a sistemas operando em caráter primário.

Country	Radio equipment approval number	Country	Radio equipment approval number	Country	Radio equipment approval number
Dubai	Huf Electronics Bretten GmbH Model: TSSRE4A Model: TSSSG4G6 TRA Registered No: ERXXXXX/XX Dealer No: DAXXXXXXX/XX	European Union Iceland Norway	 <p>Hereby, Huf Hüsbeck & Fürst GmbH & Co. KG declares that the radio equipment type TSSRE4A & TSSSG4G6 is in compliance with Directive 2014/53/EU.</p> <p>The full text of the EU declaration of conformity is available at the following internet address: http:// www.huf-group.com/eudoc</p> <p>Frequency band: 433,92 MHz Maximum Transmission Power: <10 mW Manufacturer: Huf Electronics Bretten GmbH Gewerbestr. 40</p>		75015 Bretten Germany
				Indonesia	POSTEL 827872337732
				Israel	<p>A. The use of this product does not need a wireless operation license.</p> <p>B. The product does not include an RF disturbance protection, and should not disturb other licensed products.</p> <p>C. It is forbidden to replace the antenna or to make any change in this product.</p>

Country	Radio equipment approval number
Jordan	Kingdom of Jordan Type approval for Tyre Pressure Sensor and ECU Manufacturer: Huf Electronics Bretten GmbH Model: TSSRE4Dg Type Approval Number: TRC/LPD/2017/223 Model: TSSSG4G6 Type Approval Number: TRC/LPD/2017/223
Malaysia	XXXX/XXX/XXXX/XXXXXX
Morocco	AGREE PAR L'ANRT MAROC Numero d'agrement: MR XXXXX ANRT 2017 Date d'agrement: XX/XX/2017
Mexico	IFT: XXXXXXXXXXX-XXXX IFT: XXXXXXXXXXX-XXXX

Country	Radio equipment approval number
Moldova	 1024
Oman	OMAN - TRA X/NNNN/YY Dyynnnn
Philippines	 NTC Type Approved. No: ESD-XXXXXXXX

Country	Radio equipment approval number
Russia	 Model: TSSRE4A XXXXXXXXXXXXXXXX Model: TSSSG4G6 XXXXXXXXXXXXXXXX
Singapore	Complies with IDA Standards DA103787
South Africa	 Type approval number: TA-2017/XXXX Type approval number: TA-2017/XXXX

Country	Radio equipment approval number	Country	Radio equipment approval number	Country	Radio equipment approval number
Taiwan	 <p>經型式認證合格之低功率射頻電機,非經許可,公司、商號或使用者均不得擅自變更頻率、加大功率或變更原設計之特性及功能。低功率射頻電機之使用不得影響飛航安全及干擾合法通信;經發現有干擾現象時,應立即停用,並改善至無干擾時方得繼續使用。前項合法通信,指依電信法規定作業之無線電通信。低功率射頻電機須忍受合法通信或工業、科學及醫療用電波輻射性電機設備之干擾。</p>		<p>According to “Administrative Regulations on Low Power Radio Waves Radiated Devices”.</p> <p>Without permission granted by the DGT, any company, enterprise, or user is not allowed to change frequency, enhance transmitting power or alter original characteristic as well as performance to a approved low power radio-frequency devices.</p> <p>The low power radio-frequency devices shall not influence aircraft security and interfere legal communications; If found, the user shall cease operating immediately until no interference is achieved.</p> <p>The said legal communications means radio communications is operated in compliance with the Telecommunications Act.</p>		<p>The low power radio-frequency devices must be susceptible with the interference from legal communications or ISM radio wave radiated devices.</p> <p>Thailand This telecommunication equipment conforms to NTC technical requirement.</p> <p>Ukraine  XX.XXX.XX.XXXX-XX</p> <p>United Arab Emirates Huf Electronics Bretten GmbH Model: TSSRE4A Model: TSSSG4G6 TRA Registered No: ERXXXXX/XX Dealer No: DAXXXXXXX/XX</p>

Tyre pressure loss warning system

Function of the tyre pressure loss warning system

The tyre pressure loss warning system warns the driver by means of display messages when there is a severe tyre pressure loss.

After a change in tyre pressure, a wheel rotation or a wheel change, the tyre pressure loss warning system has to be taught-in again by being restarted (→ page 417).

The tyre pressure loss warning system does not replace the need to regularly check the tyre pressures.

System limitations

The system may be impaired or may not function in the following situations:

- If the tyre pressure is set incorrectly.
- If there is a sudden pressure loss caused, for example, by a foreign object penetrating the tyre.
- If the pressure loss in several tyres decreases at the same rate.

The system has a limited or delayed function:

- When the road surface is poor, e.g. snow or gravel.
- When driving with snow chains.
- When driving in a very sporty driving style with high cornering speeds or sudden acceleration.
- When driving with a high load.

Be sure to also observe the following further related subjects:

- Notes on tyre pressure (→ page 409)
- Display messages about the tyres (→ page 477)

Restarting the tyre pressure loss warning system

Requirement:

- The recommended tyre pressure is correctly set for the respective operating condition on each of the four wheels (→ page 409).

On-board computer:

↳ [Service](#) ▶ [Tyres](#)

▶ Swipe downwards on Touch Control on the left-hand side of the steering wheel. The [Tyre pressure loss warning active](#) Restart message is shown in the multifunction display.

Restart the tyre pressure loss warning system in the following situations:

- The tyre pressure has changed.
 - The wheels or tyres have been changed or newly fitted.
- ▶ To begin restart, press Touch Control on the left-hand side of the steering wheel. The [Tyre pressure now OK?](#) message is shown in the multifunction display.
- ▶ Select [Yes](#).
- ▶ To confirm restart, press Touch Control on the left-hand side of the steering wheel. The [Run Flat Indicator restarted](#) message is shown in the multifunction display.

After you have driven for a few minutes, the tyre pressure loss warning system monitors the set tyre pressures of all the tyres.

Be sure to also observe the following further related subjects:

- Notes on tyre pressure (→ page 409)

Wheel change

Notes on selecting, fitting and replacing tyres

You can ask for information regarding permitted wheel/tyre combinations at a Mercedes-Benz Service Centre.

⚠ WARNING Risk of accident due to incorrect dimensions of wheels and tyres

If wheels and tyres of the wrong size are used, the wheel brakes or wheel suspension components may become damaged.

- ▶ Always replace wheels and tyres with those that fulfil the specifications of the original part.

When replacing wheels, make sure to fit the correct:

- Designation
- Type

When replacing tyres, make sure to fit the correct:

- Designation
- Manufacturer
- Type

⚠ WARNING Risk of injury through exceeding the specified tyre load-bearing capacity or the permissible speed rating

Exceeding the specified tyre load-bearing capacity or the permissible speed rating may lead to tyre damage and to the tyres bursting.

- ▶ Therefore, only use tyre types and sizes approved for your vehicle model.

- ▶ Observe the tyre load-bearing capacity rating and speed rating required for your vehicle.

! NOTE Damage to vehicle and tyres due to non-approved tyre types and sizes

For safety reasons, only use wheels, tyres and accessories which have been approved for your vehicle by Mercedes-Benz.

These tyres have been specially adapted for use with the control systems, e.g. ABS or ESP®, and are marked as follows:

- MO = Mercedes-Benz Original
- MOE = Mercedes-Benz Original Extended (run-flat tyres only for certain wheels)
- MO1 = Mercedes-Benz Original (only certain AMG tyres)

Certain characteristics, e.g. handling, vehicle noise emissions or fuel consumption, may otherwise be adversely affected. In addition, when driving with a load, tyre dimension variations could cause the tyres to come into

contact with the body and axle components. This could result in damage to the tyres or the vehicle.

Only use tyres, wheels or accessories tested and approved by Mercedes-Benz.

! **NOTE** Risk to driving safety from retreaded tyres

Retreaded tyres are neither tested nor recommended by Mercedes-Benz, since previous damage cannot always be detected on retreaded tyres.

For this reason driving safety cannot be guaranteed.

- ▶ Do not use used tyres if you have no information about their previous usage.

! **NOTE** Possible damage to wheels or tyres when driving over obstacles

Large wheels have a lower tyre section width. The lower the tyre section width, the greater

is the risk of damage to wheels or tyres when driving over obstacles.

- ▶ Avoid obstacles or drive particularly carefully.

! **NOTE** Damage to electronic component parts from the use of tyre-fitting tools

Vehicles with a tyre pressure monitoring system: electronic component parts are located in the wheel. Tyre-fitting tools should not be applied in the area of the valve.

The tools could damage the electronic component parts.

- ▶ Have the tyres changed at a qualified specialist workshop only.

! **NOTE** Damage to summer tyres at low ambient temperatures

Using summer tyres at very low ambient temperatures can cause cracks to form, thereby damaging the tyres permanently.

- ▶ At temperatures below 7 °C use M+S-tyres.

Accessory parts that are not approved for your vehicle by Mercedes-Benz or are not being used correctly can impair the operating safety.

Before purchasing and using non-approved accessories, visit a qualified specialist workshop and enquire about:

- Suitability
- Legal stipulations
- Factory recommendations

! **WARNING** Risk of accident with high performance tyres

The special tyre tread in combination with the optimised tyre compound, means that the risk of skidding or hydroplaning on wet roads is increased.

In addition, the tyre grip is greatly reduced at a low outside temperature and tyre running temperature.

- ▶ Switch on the ESP® and adapt your driving style accordingly.
- ▶ Use M+S tyres at outside temperatures of less than 50 °F.

Observe the following when selecting, fitting and replacing tyres:

- Country-specific requirements for tyre approval that define a specific tyre type for your vehicle.

Furthermore, the use of certain tyre types in certain regions and areas of operation can be highly beneficial.

- Only use tyres and wheels of the same type (summer tyres, winter tyres, MOExtended tyres) and the same make.
- Only fit wheels of the same size on one axle (left and right).

It is only permissible to fit a different wheel size in the event of a flat tyre in order to drive to the specialist workshop.

- Only fit tyres of the correct size onto the wheels.

- Do not make any modifications to the brake system, the wheels or the tyres.

The use of shims or brake dust shields is not permitted and may invalidate the vehicle's general operating permit.

- **Vehicles with a tyre pressure monitoring system:** all fitted wheels must be equipped with functioning sensors for the tyre pressure monitoring system.
- At temperatures below 7 °C, use winter tyres or all-season tyres marked M+S for all wheels.

Winter tyres bearing the  snowflake symbol in addition to the M+S marking provide the best possible grip in wintry road conditions.

- For M+S tyres, only use tyres with the same tread.
- Observe the maximum permissible speed for the M+S tyres fitted.

If this is below the vehicle's maximum speed, this must be indicated in an appropriate label in the driver's field of vision.

- Run in new tyres at moderate speeds for the first 100 km.
- Replace the tyres after six years at the latest, regardless of wear.
- **When replacing with tyres that do not feature run-flat characteristics:** vehicles with MOExtended tyres are not equipped with a TIREFIT kit at the factory. Equip the vehicle with a TIREFIT kit after replacing with tyres that do not feature run-flat characteristics, e.g. winter tyres.

For more information on wheels and tyres, contact a qualified specialist workshop.

Be sure to also observe the following further related subjects:

- Notes on tyre pressure (→ page 409)
- Tyre pressure table (→ page 410)
- Notes on the emergency spare wheel (→ page 427)

Notes on interchanging wheels

⚠ WARNING Risk of injury through different wheel sizes

Interchanging the front and rear wheels if the wheels or tyres have different dimensions may severely impair the driving characteristics.

The disk brakes or wheel suspension components may also be damaged.

▶ Rotate front and rear wheels only if the wheels and tyres are of the same dimensions.

Interchanging the front and rear wheels if the wheels or tyres have different dimensions can render the general operating permit invalid.

The wear patterns on the front and rear wheels differ:

- Front wheels wear more on the shoulder of the tyre
- Rear wheels wear more in the centre of the tyre

On vehicles with the same front and rear wheel size, you can interchange the wheels every 5,000 to 10,000 km, depending on the wear. Ensure the direction of rotation is maintained for the wheels.

It is imperative to observe the instructions and safety notes on "Wheel change" when doing so.

Notes on storing wheels

- After removing wheels, store them in a cool, dry and preferably dark place.
- Protect the tyres from contact with oil, grease or fuel.

Overview of the tyre-change tool kit

Apart from some country-specific variants, vehicles are not equipped with a tyre-change tool kit. For more information on which tyre-changing tools are required and approved for performing a wheel change on your vehicle, consult a qualified specialist workshop.

Required tyre-change tool kits may include, for example:

- Jack
 - Chock
 - Wheel wrench
 - Centring pin
- ① The jack weighs approximately 3.4 kg. The maximum payload of the jack can be found on the sticker affixed to the jack. The jack is maintenance-free. If there is a malfunction, please contact a qualified specialist workshop.
- The tyre-change tool kit is in tool bag ① under the load compartment floor.

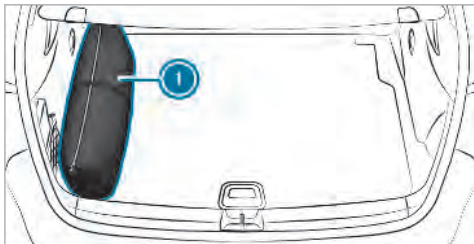

① Tool bag

Tool bag ① contains:

- Jack
- Gloves
- Wheel wrench
- Centring pin
- Folding wheel chock
- Ratchet for jack

Setting up the folding wheel chock

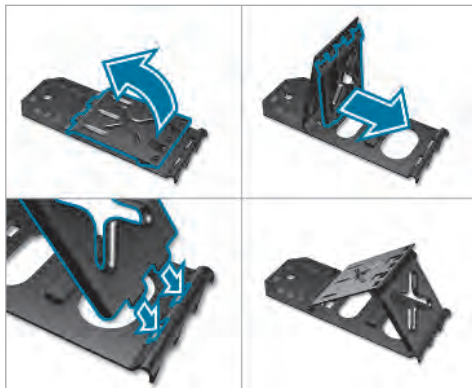

Preparing the vehicle for a wheel change

Requirements:

- The required tyre-change tool kit is available. If your vehicle is not equipped with the tyre-change tool kit, consult a qualified specialist workshop to find out about suitable tools.

- The vehicle is not on a slope.
- The vehicle is on solid, non-slippery and level ground.

- ▶ Apply the electric parking brake manually.
- ▶ Move the front wheels to the straight-ahead position.
- ▶ **Vehicles with automatic transmission:** shift into position **P**.
- ▶ Switch off the engine.
- ▶ Make sure that the engine cannot be started.
- ▶ Place chocks or other suitable items under the front and rear of the wheel that is diagonally opposite the wheel you wish to change.
- ▶ Remove the hub caps if necessary (→ page 422).
- ▶ Raising the vehicle (→ page 423).

Removing and fitting hub caps

Requirements:

- The vehicle is prepared for a wheel change (→ page 422).

Vehicles with steel wheels

The wheel trim covers the wheel bolts. Before you can unscrew the wheel bolts, you must remove the wheel trim.

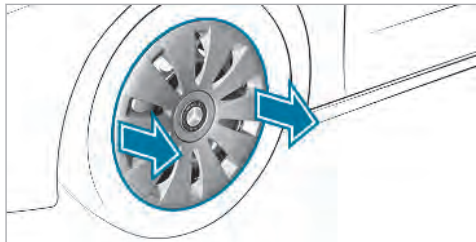

- ▶ **To remove:** using both hands, carefully reach into two wheel trim openings and remove the wheel trim.

Plastic hub cap

- ▶ **To remove:** turn the centre cover of the hub cap anti-clockwise and remove the hub cap.
- ▶ **To fit:** make sure that the centre cover of the hub cap is turned anti-clockwise.

- ▶ Position the hub cap and turn the centre cover clockwise until the hub cap engages physically and audibly.

Raising the vehicle when changing a wheel

Requirements:

- There are no persons in the vehicle.
- The vehicle has been prepared for a wheel change (→ page 422).
- The hub caps have been removed (→ page 422).

Important notes on using the jack:

- only use the vehicle-specific jack that has been tested and approved by Mercedes-Benz to raise the vehicle.
- the jack is only designed for raising and holding the vehicle for a short time while a wheel is being changed and not for maintenance work under the vehicle.
- the jack must be placed on a firm, flat and non-slip surface. If necessary, use a large, load-bearing, non-slip underlay.

- the foot of the jack must be positioned vertically under the jacking point.

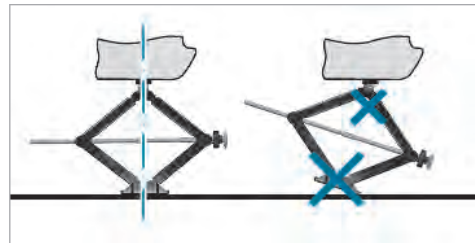

Rules of conduct when the vehicle is raised:

- Never place your hands or feet under the vehicle.
- Do not lie under the vehicle.
- Do not start the engine and do not release the electric parking brake.
- Do not open or close any doors or the tail-gate.

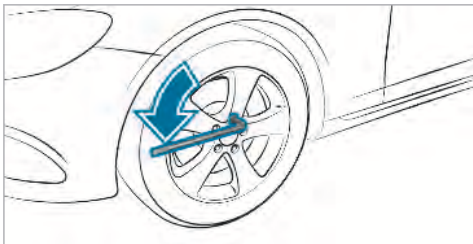

- ▶ Using the wheel wrench, loosen the wheel bolts on the wheel you wish to change by about one full turn. Do not unscrew the bolts completely.

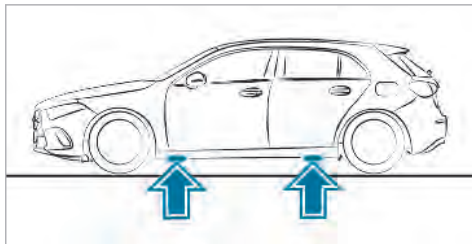

Position of jack support points

- ▲ **WARNING** Risk of injury from incorrect positioning of the jack

If you do not position the jack correctly at the appropriate jacking point of the vehicle, the jack could tip with the vehicle raised.

- ▶ Only position the jack at the appropriate jacking point of the vehicle. The base of the jack must be positioned vertically under the jacking point of the vehicle.

! **NOTE** Vehicle damage from the jack

If you do not position the jack correctly at the appropriate jack support point of the vehicle, the jack could tip over with the vehicle raised.

- ▶ The jack is designed exclusively for jacking up the vehicle at the jack support points.

- ▶ Take the ratchet ring spanner out of the tyre-change tool kit and place it on the hexagon nut of the jack so that the lettering "AUF" is visible.

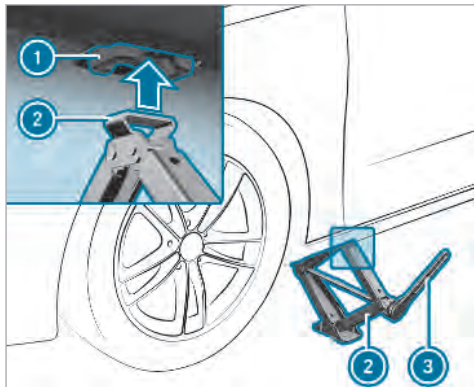

- ▶ Position jack ② at jack support point ①.
- ▶ Turn ratchet ring spanner ③ clockwise until jack ② sits completely on jack support point ① and the base of the jack lies evenly on the ground.
- ▶ Continue to turn ratchet ring spanner ③ until the tyre is raised a maximum of 3 cm off the ground.
- ▶ Loosen and remove the wheel (→ page 425).

Removing a wheel

Requirement:

- The vehicle is raised (→ page 423).

When changing a wheel, avoid applying any force to the brake discs, since this could impair the level of comfort when braking.

! **NOTE** Damage to threading from dirt on wheel bolts

▶ Do not place wheel bolts in sand or on a dirty surface.

▶ Unscrew the uppermost wheel bolt completely.

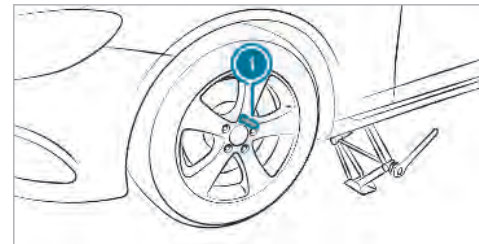

- ▶ Screw centring pin ① instead of the wheel bolt into the threading.
- ▶ Unscrew the remaining wheel bolts fully.
- ▶ Remove the wheel.
- ▶ Fit the new wheel (→ page 425).

Fitting a new wheel

Requirement:

- The wheel is removed (→ page 425).

⚠ WARNING Risk of accident from losing a wheel

Oiled, greased or damaged wheel bolt/wheel nut threads or wheel hub/wheel mounting bolt threads can cause the wheel bolts/wheel nuts to come loose.

As a result, you could lose a wheel while driving.

- ▶ Never oil or grease the threads.
- ▶ In the event of damage to the threads, contact a qualified specialist workshop immediately.
- ▶ Have the damaged wheel bolts or damaged hub threads replaced.
- ▶ Do not continue driving.

- ▶ Observe the information on the choice of tyres (→ page 418).

For tyres with a specified direction of rotation, an arrow on the side wall of the tyre indicates the correct direction of rotation. Observe the direction of rotation when fitting.

- ▶ Slide the wheel to be mounted onto the centring pin and push it on.

⚠ WARNING Risk of injury from tightening wheel bolts and nuts

If you tighten the wheel bolts or wheel nuts when the vehicle is raised, the jack could tip.

- ▶ Only tighten wheel bolts or wheel nuts when the vehicle is on the ground.

- ▶ For safety reasons, only use wheel bolts which have been approved by Mercedes-Benz and for the wheel in question.
- ▶ Tighten the wheel bolts until they are finger-tight.
- ▶ Unscrew the centring pin.
- ▶ Tighten the last wheel bolt until it is finger-tight.
- ▶ Lower the vehicle (→ page 426).

Lowering the vehicle after a wheel change

Requirements:

- The new wheel has been fitted (→ page 425).
- ▶ Place the ratchet ring spanner onto the hexagon nut of the jack so that the lettering "AB" is visible.
- ▶ **To lower the vehicle:** turn the ratchet ring spanner of the jack anti-clockwise.

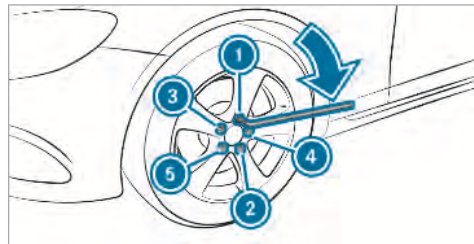

- ▶ Tighten the wheel bolts evenly in a diagonal pattern in the order indicated (① to ⑤).
Specified tightening torque: 130 Nm.

⚠ WARNING Risk of injury through incorrect tightening torque

The wheels could come loose if the wheel bolts or wheel nuts are not tightened to the prescribed tightening torque.

- ▶ Have the tightening torque checked immediately at a qualified specialist workshop after changing a wheel.

- ▶ Check the tyre pressure of the newly mounted wheel and adjust accordingly.
- ▶ **Vehicles with tyre pressure loss warning system:** restart the tyre pressure loss warning system (→ page 417).
Exception: the new wheel is an emergency spare wheel.
- ▶ **Vehicles with a tyre pressure monitoring system:** restart the tyre pressure monitoring system (→ page 412).
Exception: the new wheel is an emergency spare wheel.

Make sure to observe the following further related subject:

- Notes on tyre pressure (→ page 409)

Emergency spare wheel

Notes on the emergency spare wheel

⚠ WARNING Risk of accident caused by incorrect wheel and tyre dimensions

The wheel or tyre size and the tyre type of the emergency spare wheel or spare wheel and the wheel to be replaced may differ. Mounting an emergency spare wheel/spare wheel may severely impair the driving characteristics.

To prevent hazardous situations:

- ▶ Adapt your driving style accordingly and drive carefully.
- ▶ Never fit more than one emergency spare wheel or spare wheel that differs in size.

- ▶ Only use an emergency spare wheel or spare wheel of a different size briefly.
- ▶ Do not switch off ESP®.
- ▶ Have the emergency spare wheel or spare wheel of a different size replaced at the nearest qualified specialist workshop. The new wheel must have the correct dimensions.

Check the tyre pressure of the emergency spare wheel fitted. Correct the pressure as necessary.

The maximum permissible speed with an emergency spare wheel fitted is 80 km/h.

Do not fit the emergency spare wheel with snow chains.

Replace the emergency spare wheel after six years at the latest, regardless of wear.

- ⓘ **Vehicles with a tyre pressure loss warning system:** If an emergency spare wheel is fitted the tyre pressure loss warning system cannot function reliably. Only restart the system again when the emergency spare wheel has been replaced with a new wheel.

Vehicles with a tyre pressure monitoring system: If an emergency spare wheel is fitted the tyre pressure monitoring system cannot function reliably. Only restart the system again when the emergency spare wheel has been replaced with a new wheel.

Vehicles with a tyre pressure monitoring system: For a few minutes after an emergency spare wheel is fitted, the system may still display the tyre pressure of the removed wheel.

Be sure to also observe the following further related subjects:

- Notes on tyre pressure (→ page 409)
- Tyre pressure table (→ page 410)

Removing the emergency spare wheel

The emergency spare wheel is secured in the emergency spare wheel bag in the load compartment.

- ▶ Observe the information on mounting tyres (→ page 418).
- ▶ Open the tailgate.

- ▶ Detach the fastening straps.
- ▶ Unhook the retaining spring hooks of the fastening straps from the brackets.
- ▶ Remove the emergency spare wheel bag with the emergency spare wheel.
- ▶ Open the emergency spare wheel bag and remove the emergency spare wheel.

Notes on technical data

The technical data was determined in accordance with EU Directives. The data stated only applies to vehicles with standard equipment. You can obtain further information from a Mercedes-Benz Service Centre.

Only for certain countries: you can find vehicle-specific vehicle data in the EC-Certificate of Conformity (CERTIFICATE OF CONFORMITY). These documents are delivered with your vehicle.

On-board electronics

Notes on tampering with the engine electronics

! **NOTE** Premature wear through improper maintenance

Improper maintenance may cause vehicle components to wear more quickly and the vehicle's operating permit may be invalidated.

▶ Always have work on the engine electronics and related components carried out at a qualified specialist workshop.

Two-way radios

Notes on installing two-way radios

! **WARNING** Risk of accident due to improper work on two-way radios

The electromagnetic radiation from two-way radios can interfere with the on-board electronics if RF transmitters are manipulated or retrofitted incorrectly.

This could jeopardise the operating safety of the vehicle.

▶ You should have all work on electrical and electronic components carried out at a qualified specialist workshop.

! **WARNING** Risk of accident from incorrect operation of two-way radios

If you operate two-way radios incorrectly in the vehicle, the electromagnetic radiation could interfere with the on-board electronics, e.g.:

- if the two-way radio is not connected to an exterior aerial
- if the exterior aerial is not correctly mounted or is not of low reflection

This could jeopardise the operating safety of the vehicle.

- ▶ Have the low-reflection exterior aerial fitted at a qualified specialist workshop.
- ▶ When operating two-way radios in the vehicle, always connect them to the low-reflection exterior aerial.

! **NOTE** Invalidation of the operating permit due to failure to comply with the instructions for installation and use

The operating permit may be invalidated if the instructions for installation and use of two-way radios are not observed.

- ▶ Only use approved frequency bands.
- ▶ Observe the maximum permissible output power in these frequency bands.
- ▶ Only use approved aerial positions.

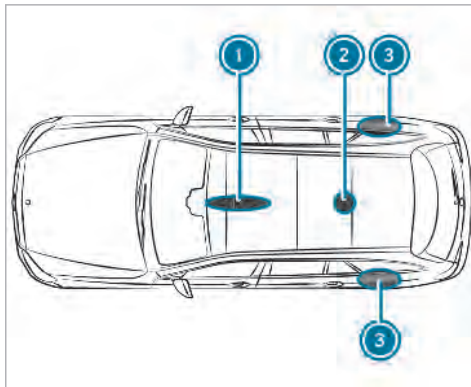

- ① Front roof area
- ② Rear roof area
- ③ Rear wing

On vehicles with a panoramic sliding sunroof, installing an aerial to the front or rear roof area is not permitted.

On the rear wings, it is recommended that you install the aerial on the side of the vehicle closest to the centre of the road.

Use Technical Specification ISO/TS 21609 (Road Vehicles - "EMCs for installation of aftermarket radio frequency transmitting equipment") when retrofitting two-way radios. Comply with the legal requirements for detachable parts.

If your vehicle has fittings for two-way radio equipment, use the power supply or aerial connectors intended for use with the basic wiring. Be sure to observe the manufacturer's Supplements when installing.

Two-way radio transmission output

The maximum transmission output (PEAK) at the base of the aerial must not exceed the values in the following table:

frequency band and maximum transmission output

Frequency band	Maximum transmission output
Short wave 3 - 54 MHz	100 W
4 m frequency band 74 - 88 MHz	30 W
2 m frequency band 144 - 174 MHz	50 W
Trunked radio system/Tetra 380 - 460 MHz	10 W
70 cm frequency band 420 - 450 MHz	35 W
Two-way radio (2G/3G/4G)	10 W

The following can be used in the vehicle without restrictions:

- two-way radios with a maximum transmission output of up to 100 mW
- two-way radios with transmitter frequencies in the 380 - 410 MHz frequency band and a maximum transmission output of up to 2 W (trunked radio system/Tetra)
- mobile phones (2G/3G/4G)

There are no restrictions when positioning the aerial on the outside of the vehicle for the following frequency bands:

- trunked radio system/Tetra
- 70 cm frequency band
- 2G/3G/4G

Vehicle identification plate, VIN and engine number

Vehicle identification plate

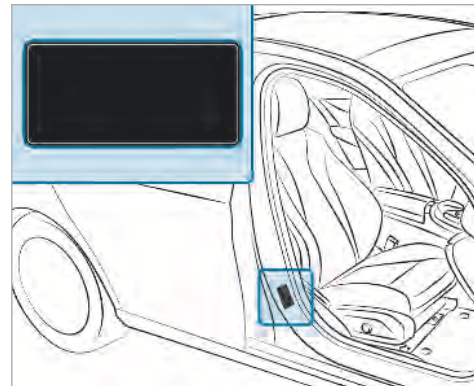

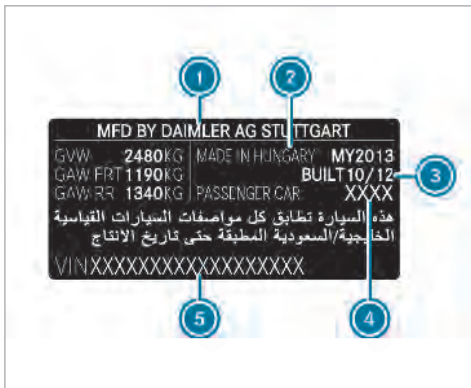

Vehicle identification plate (example: Kuwait)

- ① Vehicle manufacturer
- ② Place of manufacture
- ③ Manufacturing date
- ④ Vehicle model
- ⑤ VIN

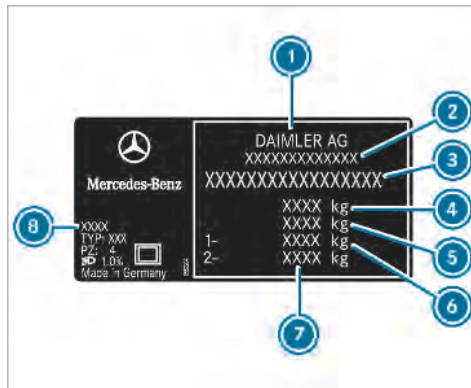

Vehicle identification plate (example: all other countries)

- ① Vehicle manufacturer
- ② EU general operating permit number (only for certain countries)
- ③ VIN (vehicle identification number)
- ④ Permissible gross mass (kg)
- ⑤ Permissible gross mass of vehicle combination (kg) (only for specific countries)
- ⑥ Permissible front axle load (kg)
- ⑦ Permissible rear axle load (kg)
- ⑧ Paint code

- ⑥ Permissible front axle load (kg)
- ⑦ Permissible rear axle load (kg)
- ⑧ Paint code
- ⓘ The data shown in the illustration is example data.

VIN and engine number

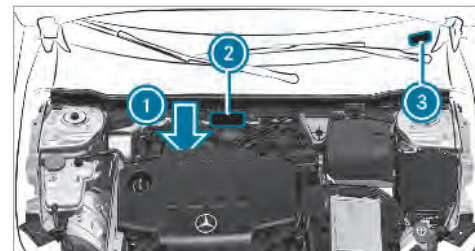

- ① Engine number stamped into the crankcase
- ② VIN (vehicle identification number) stamped into the crossmember
- ③ VIN (vehicle identification number) at the lower edge of the windscreen



The VIN at the lower edge of the windscreen  is only available in some countries. You can obtain further information from any qualified specialist workshop.

Operating fluids

Notes on operating fluids

 **WARNING** Risk of injury from operating fluids harmful to your health

Operating fluids may be poisonous and harmful to your health.

-  Observe the text on the original containers when using, storing or disposing of operating fluids.
-  Always store operating fluids sealed in their original containers.
-  Always keep children away from operating fluids.



ENVIRONMENTAL NOTE Environmental pollution caused by environmentally irresponsible disposal



Dispose of operating fluids in an environmentally responsible manner.

Operating fluids include the following:

- fuels
- exhaust gas aftertreatment additives, e.g. AdBlue[®]
- lubricants
- coolant
- brake fluid
- windscreen washer fluid
- climate control system refrigerant

Only use products approved by Mercedes-Benz. Damage caused by the use of products that have not been approved is not covered by the Mercedes-Benz warranty or goodwill gestures.

You can identify operating fluids approved by Mercedes-Benz by the following inscription on the containers:

- MB-Freigabe (e.g. MB-Freigabe 229.51)
- MB-Approval (e.g. MB-Approval 229.51)



Further information on approved operating fluids:

- in the Mercedes-Benz Specifications for operating fluids at <http://bevo.mercedes-benz.com> (by entering the designation)
- in the Mercedes-Benz Specifications for Operating Fluids in the Mercedes-Benz BeVo app (by entering the designation)
- at a qualified specialist workshop



WARNING Risk of fire or explosion from fuel

Fuels are highly flammable.

-  Fire, naked flames, smoking and creating sparks must be avoided.
-  Switch off the ignition and, if it has been in use, switch off the stationary heater before you refuel your vehicle.

⚠ WARNING Risk of injury from fuel

Fuels are poisonous and harmful to your health

- ▶ Do not swallow fuel or let it come into contact with skin, eyes or clothing.
- ▶ Do not inhale fuel vapour.
- ▶ Keep children away from fuel.

If you or other people come into contact with fuel, observe the following:

- ▶ Immediately rinse fuel off your skin with soap and water.
- ▶ If fuel comes into contact with your eyes, immediately rinse them thoroughly with clean water. Seek medical attention immediately.
- ▶ If you swallow fuel, seek medical attention immediately. Do not induce vomiting.
- ▶ Change immediately out of clothing that has come into contact with fuel.

Fuel**Information on fuel grades for vehicles with petrol engines**

Observe the notes on operating fluids (→ page 433).

! NOTE Damage caused by the wrong fuel

Even small amounts of the wrong fuel could result in damage to the fuel system, the engine and the emission control system.

- ▶ Only refuel using unleaded fuel that conforms to EN 228, or an equivalent specification.

Fuel of this specification may contain up to 10 % ethanol. Your vehicle is suitable for use with E10 fuel.

Do not refuel using:

- diesel
- E85, E100
- petrol containing methanol (M15, M30, M85, M100)

- petrol with additives containing metal

If you accidentally refuel with the wrong fuel:

- ▶ do not switch the ignition on.
- ▶ consult a qualified specialist workshop.

If the available fuel is not sufficiently low in sulphur, this can produce unpleasant odours.

The recommended octane number for your vehicle can be found on the instruction label in the fuel filler flap (→ page 154).

As a temporary measure, if the recommended fuel is not available, you may also use regular unleaded petrol with at least 91 RON. This may reduce engine output and increase fuel consumption.

Never refuel using petrol with a lower RON.

Further information on fuel can be found:

- at a filling station
- at a qualified specialist workshop

Information on additives in petrol

Observe the notes on service products (→ page 433).

! **NOTE** Damage caused by non-approved additives

Even small amounts of the wrong additive may lead to malfunctions occurring.

▶ Only add cleaning additives recommended by Mercedes-Benz to the fuel.

Mercedes-Benz recommends that you use brand-name fuels with additives.

The fuel grade available in some countries may not be sufficient. Residue could build up in the fuel injection system as a result. In this case, in consultation with a Mercedes-Benz Service Centre, the fuel may be mixed with the cleaning additive recommended by Mercedes-Benz. Be sure to observe the notes and mixing ratios specified on the container.

Information on fuel grades for vehicles with a diesel engine

General notes

Observe the notes on operating fluids (→ page 433).

! **WARNING** Risk of fire through fuel mixture

If you mix diesel fuel with petrol, the flash point of the fuel mixture is lower than that of pure diesel fuel.

While the engine is running, component parts in the exhaust system may overheat unnoticed.

▶ Never refuel using petrol.

▶ Never mix diesel fuel with petrol.

! **NOTE** Damage caused by the wrong fuel

Even small amounts of the wrong fuel could result in damage to the fuel system, the engine and the emission control system.

▶ Only refuel using diesel fuel that conforms to EN 590, or an equivalent specification.

▶ **Vehicles with diesel particulate filters:** in countries outside the EU, only use low-sulphur Euro diesel with a sulphur content of under 50 ppm.

Do not use the following:

- petrol
- marine diesel
- heating oil
- bio-diesel
- vegetable oil
- paraffin
- kerosene

Information on low outside temperatures

Refuel your vehicle with as much winter diesel fuel as possible at the beginning of winter.

Before changing over to winter diesel fuel, the fuel tank should be empty, if possible. When refuelling with winter diesel fuel for the first time, keep the fuel level low, for example at reserve level. The fuel tank can be filled as usual when next refuelling.

Further information on fuel can be found:

- at a filling station
- at a qualified specialist workshop

Tank content and fuel reserve

The total capacity of the fuel tank may vary, depending on the vehicle equipment.

Capacity

Model	Total capacity
A 250	43.0 l or 51.0 l
All other models	43.0 l
Model	of which reserve fuel
All models	5.0 l

Adblue®**Notes on AdBlue®**

Observe the notes on operating fluids (→ page 433).

AdBlue® is a water-soluble fluid for the exhaust gas aftertreatment of diesel engines.

! **NOTE** Damage caused by mixing additives with AdBlue® or from diluting AdBlue®

The BlueTEC exhaust gas aftertreatment system could be destroyed by:

- Additives in AdBlue®
 - Diluting AdBlue®
- ▶ Only use AdBlue® in accordance with ISO 22241.
- ▶ Do not add additives.
- ▶ Do not dilute AdBlue®.

! **NOTE** Damage and malfunctions due to impurities in AdBlue®

Impurities in AdBlue® lead to:

- Increased emissions values
- Damage to the catalytic converter
- Engine damage
- BlueTEC exhaust gas aftertreatment malfunctions

▶ Avoid impurities in AdBlue®.

🔥 ENVIRONMENTAL NOTE Contamination caused by AdBlue®

AdBlue® residues crystallise after a period of time, and contaminate the surfaces with which they come into contact.

▶ Surfaces that have come into contact with AdBlue® while refilling must be immediately rinsed with water, or AdBlue® must be removed with a damp cloth and cold water.

If AdBlue® has already crystallised, clean it with a sponge and cold water.

When you open the AdBlue® tank, small amounts of ammonia vapour may escape. Do not inhale any ammonia vapours that may be released. Only fill the AdBlue® tank in well-ventilated areas.

AdBlue® capacity

Missing values were not available at the time of going to press.

Total capacity of AdBlue® tank

Model	Total capacity
All models	23.8 l

Engine oil

Notes on engine oil

Observe the notes on service products (→ page 433).



! **NOTE** Engine damage caused by an incorrect oil filter, incorrect oil or additives

- ▶ Do not use engine oils or oil filters which do not correspond to the specifications explicitly prescribed for the service intervals.
- ▶ Do not alter the engine oil or oil filter in order to achieve longer change intervals than prescribed.
- ▶ Do not use additives.
- ▶ Have the engine oil renewed at regular intervals.

Mercedes-Benz recommends that you have the oil change carried out at a qualified specialist workshop.

Only Mercedes-Benz approved engine oils may be used in Mercedes-Benz engines.

Further information on engine oils and oil filters:

- in the Mercedes-Benz Specifications for Service Products at <http://bevo.mercedes-benz.com> (by entering the designation)

- at a qualified specialist workshop

Petrol engines: for certain countries, different engine oils can be used in conjunction with reduced maintenance intervals.

i Further information on different engine oils can be obtained at a qualified specialist workshop.

Quality and capacity of engine oil

MB-Freigabe or MB-Approval

Petrol engines	MB-Freigabe or MB-Approval
All models	229.51, 229.52, 229.61, 229.71

MB-Freigabe or MB-Approval

Diesel engines	MB-Freigabe or MB-Approval
All models	226.51, 229.31, 229.51, 229.52, 229.61, 229.71

If the engine oils listed in the table are not available, you may add a maximum of 1.0 l of the following engine oils once only:

- **petrol engines:** MB-Freigabe or MB-Approval 229.31 or ACEA C3
- **diesel engines:** ACEA C3

The following values refer to an oil change, including the oil filter.

Replacement amount

Model	Replacement amount
A 180 d	5.5 l
All other models	5.1 l

Notes on brake fluid

Observe the notes on operating fluids (→ page 433).

⚠ WARNING Risk of an accident due to vapour pockets forming in the brake system

The brake fluid constantly absorbs moisture from the air. This lowers the boiling point of the brake fluid. If the boiling point is too low, vapour pockets may form in the brake system when the brakes are applied hard.

This impairs the braking effect.

- ▶ Have the brake fluid renewed at the specified intervals.

Have the brake fluid regularly changed at a qualified specialist workshop.

Only use brake fluid approved by Mercedes-Benz according to MB-Freigabe or MB-Approval 331.0.

Further information on brake fluid:

- in the Mercedes-Benz Specifications for Operating Fluids at <http://bevo.mercedes-benz.com>
- at a qualified specialist workshop

Coolant

Notes on coolant

Observe the notes on service products (→ page 433).

⚠ WARNING Risk of fire- and injury from antifreeze

If antifreeze comes into contact with hot component parts in the engine compartment, it may ignite.

- ▶ Allow the engine to cool down before you top up the antifreeze.
- ▶ Make sure that no antifreeze spills out next to the filler opening.
- ▶ Thoroughly clean the antifreeze from component parts before starting the vehicle.

! **NOTE** Damage caused by incorrect coolant

- ▶ Only add coolant that has been pre-mixed with the required antifreeze protection.

Further information on coolant:

- In the Mercedes-Benz Specifications for Operating Fluids 310.1, e.g. online at <http://bevo.mercedes-benz.com>.
- At a qualified specialist workshop.

! **NOTE** Overheating at high outside temperatures

If an inappropriate coolant is used, the engine cooling system is not sufficiently protected against overheating and corrosion at high outside temperatures.

- ▶ Always use coolant approved by Mercedes-Benz.
- ▶ Observe the instructions in the Mercedes-Benz Specifications for Operating Fluids 310.1.

Have the coolant regularly replaced at a qualified specialist workshop.

The proportion of corrosion inhibitor/antifreeze concentrate in the engine cooling system should be:

- a minimum of 50% (antifreeze protection down to approximately -37 °C).
- a maximum of 55% (antifreeze protection down to -45 °C).

Notes on windscreen washer fluid

Observe the notes on service products (→ page 433).

! **WARNING** - Risk of fire and injury due to windscreen washer concentrate

Windscreen washer concentrate is highly flammable. It could ignite if it comes into contact with hot engine component parts or the exhaust system.

- ▶ Make sure that no windscreen washer concentrate spills out next to the filler opening.

! **NOTE** Damage to the exterior lighting due to unsuitable windscreen washer fluid

Unsuitable windscreen washer fluids may damage the plastic surface of the exterior lighting.

- ▶ Only use windscreen washer fluids which are also suitable for use on plastic surfaces, e.g. MB SummerFit or MB WinterFit.

! **NOTE** Blocked spray nozzles caused by mixing windscreen washer fluids

- ▶ Do not mix MB SummerFit and MB WinterFit with other windscreen washer fluids.

Do not use distilled or de-ionised water as the fill level sensor may be triggered erroneously.

Recommended windscreen washer fluid:

- Above freezing point: e.g. MB SummerFit
- Below freezing point: e.g. MB WinterFit

For the correct mixing ratio, refer to the information on the antifreeze container.

Mix the washer fluid with the windscreen washer fluid all year round.

Vehicle data

Vehicle dimensions

The heights specified may vary as a result of the:

- tyres
- load
- condition of the suspension
- optional equipment

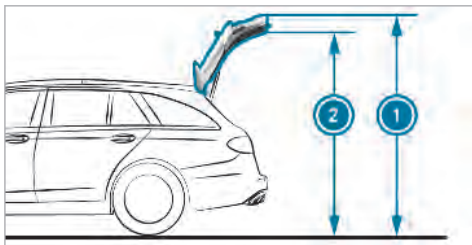

Height when opened and headroom

Model	① Height when opened	② Headroom
A 250	2002 mm	1857 mm
All other models	1997 mm	1852 mm

Vehicle dimensions

All models	
Vehicle length	4419 mm
Vehicle width including outside mirrors	1992 mm
Vehicle width excluding outside mirrors	1796 mm
Wheelbase	2729 mm

Vehicle height

Model	Height
A 250	1445 mm
All other models	1440 mm

Weights and loads

Please note that for the specified vehicle data:

- items of optional equipment increase the unladen weight and reduce the payload.
- vehicle-specific weight information can be found on the vehicle identification plate .

Roof load

All models	
Maximum roof load	100 kg

Trailer hitch

General notes on the trailer hitch

Not all models can be used to tow a trailer (→ page 221).

Modifications to the engine cooling system may be necessary, depending on the vehicle model. The retrofitting of a trailer hitch is only permissible if a towing capacity is specified in your vehicle documents.

Further information can be obtained at a qualified specialist workshop.

Mounting dimensions

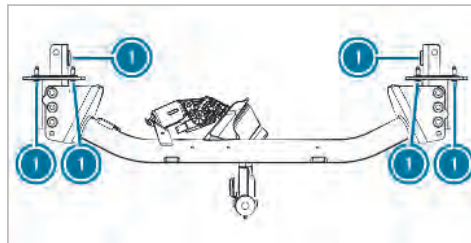
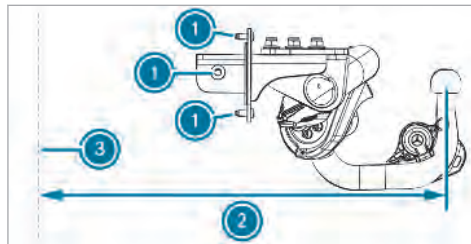

- ① Fastening point
- ② Overhang dimension
- ③ Rear axle centre line

The overhang dimension and fastening points are valid for a trailer hitch installed at the factory.

Missing values were not available at the time of going to press.

Model	② Overhang dimension
All models	

Permissible towing capacity

The tongue weight is not included in the towing capacity.

Permissible towing capacity, braked (at a minimum start-off gradeability of 8 %)

Model	Permissible towing capacity, braked
A 180 d	1600 kg
All other models	1800 kg

Permissible towing capacity, braked (at a minimum start-off gradeability of 12 %)

Model	Permissible towing capacity, braked
A 180 d	1400 kg
All other models	1600 kg

Permissible towing capacity, unbraked

Model	Permissible towing capacity, unbraked
A 180 d	705 kg
A 200	680 kg
A 250	720 kg

Maximum tongue weight

! **NOTE** Damage caused by the trailer coming loose

If the tongue weight used is too low, the trailer may come loose.

- ▶ The tongue weight must not be below 50 kg.
- ▶ Use a tongue weight that is as close as possible to the maximum permissible tongue weight.

Maximum tongue weight

Model	
All models	80 kg

Permissible rear axle load during trailer operation**Axle load**

Model	Axle load
A 180 d	970 kg
A 200	976 kg
A 250	986 kg

Display messages

Introduction

Notes on display messages

Display messages appear on the multifunction display.



Display messages with graphic symbols are simplified in the Owner's Manual and may differ from the symbols on the multifunction display. The multifunction display shows high-priority display messages in red. Certain display messages are accompanied by a warning tone.

Please respond in accordance with the display messages and follow the additional notes in this Owner's Manual.

For some display messages, a symbol is also shown:

-  Further information

-  Hide display message

You can select the desired symbol by swiping left or right on the left-hand touch control. Press the  symbol to show further information on the multifunction display. Press the  symbol to hide the display message.

You can hide low-priority display messages by pressing the  button or the left-hand touch control. The display messages are then stored in the message memory.

Rectify the cause of a display message as quickly as possible.

High-priority display messages cannot be hidden. The multifunction display shows these display messages continuously until the cause of the message has been rectified.

Calling up stored display messages

On-board computer:

 Service  1 message

If there are no display messages, **No messages** appears on the multifunction display.

▶ Scroll through the display messages by swiping upwards or downwards on the left-hand touch control.

▶ **To exit the message memory:** press the  button.

Safety systems

Display messages	Possible causes/consequences and ► Solutions
 <p data-bbox="53 453 359 515">inoperative See Owner's Manual</p>	<p data-bbox="466 236 1921 384">* ABS and ESP[®] are malfunctioning. Other driving and driving safety systems may also be malfunctioning. The brake system continues to operate normally. The braking distance may increase in an emergency braking situation.</p> <div data-bbox="492 410 1917 715" style="border: 1px solid gray; padding: 5px;"> <p data-bbox="513 420 1351 453">▲ WARNING Risk of skidding if ABS and ESP[®] are malfunctioning</p> <p data-bbox="513 474 1847 536">If ABS and ESP[®] are malfunctioning, the wheels could lock when braking and ESP[®] cannot carry out vehicle stabilisation.</p> <p data-bbox="513 552 1800 614">The steering capability and braking characteristics are thus severely impaired. The braking distance may increase in an emergency braking situation. In addition, other driving safety systems are switched off.</p> <ul data-bbox="513 629 1500 705" style="list-style-type: none"> <li data-bbox="513 629 778 660">► Drive on carefully. <li data-bbox="513 671 1500 705">► Have ABS and ESP[®] checked immediately at a qualified specialist workshop. </div> <ul data-bbox="486 738 1181 809" style="list-style-type: none"> <li data-bbox="486 738 758 769">► Drive on carefully. <li data-bbox="486 780 1181 809">► Consult a qualified specialist workshop immediately.

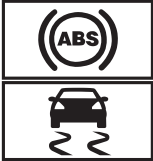
Display messages	Possible causes/consequences and ► Solutions
 <p data-bbox="118 408 433 464">currently unavailable See Owner's Manual</p>	<p data-bbox="527 184 1085 215">* ABS and ESP[®] are temporarily unavailable.</p> <p data-bbox="553 228 1620 260">Other driving systems and driving safety systems may also be temporarily unavailable.</p> <p data-bbox="553 273 1984 332">The brake system continues to operate normally. The braking distance may increase in an emergency braking situation.</p> <div data-bbox="553 360 1984 668" style="background-color: #f0f0f0; padding: 10px;"> <p data-bbox="578 370 1416 405">▲ WARNING Risk of skidding if ABS and ESP[®] are malfunctioning</p> <p data-bbox="574 422 1913 487">If ABS and ESP[®] are malfunctioning, the wheels could lock when braking and ESP[®] cannot carry out vehicle stabilisation.</p> <p data-bbox="574 501 1868 566">The steering capability and braking characteristics are thus severely impaired. The braking distance may increase in an emergency braking situation. In addition, other driving safety systems are switched off.</p> <ul style="list-style-type: none"> <li data-bbox="574 578 844 609">► Drive on carefully. <li data-bbox="574 622 1565 653">► Have ABS and ESP[®] checked immediately at a qualified specialist workshop. </div> <ul style="list-style-type: none"> <li data-bbox="553 687 1921 718">► Drive carefully on a suitable stretch of road, making slight steering movements at a speed above 30 km/h. <li data-bbox="553 732 1970 763">► If the display message does not disappear, consult a qualified specialist workshop immediately. Drive carefully.

Display messages



currently unavailable See
Owner's Manual

Possible causes/consequences and ► Solutions

- * ESP® is temporarily unavailable.
Other driving and driving safety systems may also be malfunctioning.



⚠ WARNING Risk of skidding if ESP® is malfunctioning



If ESP® is malfunctioning, ESP® cannot carry out vehicle stabilisation. In addition, other driving safety systems are switched off.

- Drive on carefully.
- Have ESP® checked at a qualified specialist workshop.

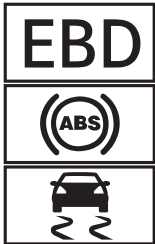
- Carefully drive on a suitable stretch of road, making slight steering movements at a speed above 30 km/h.
- If the display message does not disappear, consult a qualified specialist workshop immediately. Drive carefully.

Display messages	Possible causes/consequences and ► Solutions
 <p data-bbox="118 298 425 360">inoperative See Owner's Manual</p>	<p data-bbox="527 184 848 215">* ESP® is malfunctioning.</p> <p data-bbox="551 228 1406 260">Other driving and driving safety systems may also be malfunctioning.</p> <p data-bbox="551 273 1984 335">The brake system continues to operate normally. The braking distance may increase in an emergency braking situation.</p> <div data-bbox="551 360 1984 415"><p data-bbox="578 370 1283 405">▲ WARNING Risk of skidding if ESP® is malfunctioning</p></div> <p data-bbox="572 425 1943 487">If ESP® is malfunctioning, ESP® cannot carry out vehicle stabilisation. In addition, other driving safety systems are switched off.</p> <ul data-bbox="572 501 1295 581" style="list-style-type: none"><li data-bbox="572 501 842 532">► Drive on carefully.<li data-bbox="572 545 1295 581">► Have ESP® checked at a qualified specialist workshop. <ul data-bbox="551 615 1248 687" style="list-style-type: none"><li data-bbox="551 615 819 646">► Drive on carefully.<li data-bbox="551 659 1248 687">► Consult a qualified specialist workshop immediately.

Display messages	Possible causes/consequences and ► Solutions
 <p data-bbox="53 511 359 570">inoperative See Owner's Manual</p>	<p data-bbox="466 184 1344 260">* EBD, ABS and ESP[®] are malfunctioning. Other driving and driving safety systems may also be malfunctioning.</p> <div data-bbox="492 282 1917 339" style="background-color: #f0f0f0; padding: 5px;"> <p data-bbox="513 293 1418 329">⚠ WARNING Risk of skidding if EBD, ABS and ESP[®] are malfunctioning</p> </div> <p data-bbox="506 350 1892 412">If EBD, ABS and ESP[®] are malfunctioning, the wheels can lock when braking and ESP[®] cannot carry out vehicle stabilisation.</p> <p data-bbox="506 425 1806 487">The steering capability and braking characteristics are thus severely impaired. The braking distance may increase in an emergency braking situation. In addition, other driving safety systems are switched off.</p> <ul data-bbox="506 501 1535 573" style="list-style-type: none"> ▶ Drive on carefully. ▶ Have the brake system checked immediately at a qualified specialist workshop. <ul data-bbox="486 609 1181 681" style="list-style-type: none"> ▶ Drive on carefully. ▶ Consult a qualified specialist workshop immediately.
 <p data-bbox="53 816 376 878">Turn on the ignition to release the parking brake</p>	<p data-bbox="466 702 1569 774">* The red  indicator lamp is lit. You have attempted to release the electric parking brake with the ignition switched off.</p> <ul data-bbox="486 785 813 816" style="list-style-type: none"> ▶ Switch the ignition on.

Display messages	Possible causes/consequences and ► Solutions
 <p data-bbox="118 298 396 329">Release parking brake</p>	<p data-bbox="527 182 1007 213">* The red  indicator lamp flashes.</p> <p data-bbox="553 225 1273 256">The electric parking brake is applied while you are driving:</p> <ul data-bbox="560 267 1559 344" style="list-style-type: none"><li data-bbox="560 267 1559 298">• A condition for automatic release of the electric parking brake is not fulfilled .<li data-bbox="560 308 1494 344">• You are performing emergency braking using the electric parking brake . <p data-bbox="553 363 1702 394">► Check that the conditions for automatic release of the electric parking brake are fulfilled.</p> <p data-bbox="553 405 1146 436">► Release the electric parking brake manually.</p>

Display messages



Parking brake See Owner's Manual

Possible causes/consequences and ► Solutions



* The yellow  indicator lamp is lit. The electric parking brake is malfunctioning.

To apply:

- Switch off the ignition and switch it back on.
- Apply the electric parking brake manually .

If it is not possible to apply the electric parking brake:

- Consult a qualified specialist workshop.
- Where necessary, also safeguard the parked vehicle against rolling away.

The yellow  indicator lamp and the red  indicator lamp are lit. The electric parking brake is malfunctioning.

To release:



- Switch off the ignition and switch it back on.
- Release the electric parking brake manually .

or



- Release the electric parking brake automatically .

If it is still not possible to release the electric parking brake:



- Do not continue driving under any circumstances. Consult a qualified specialist workshop.

The yellow  indicator lamp is lit and the red  indicator lamp is flashing. The electric parking brake is malfunctioning.



The electric parking brake could not be applied or released.





Display messages	Possible causes/consequences and ► Solutions
	<ul style="list-style-type: none">► Switch off the ignition and switch it back on. <p>To apply:</p> <ul style="list-style-type: none">► Release and then apply the electric parking brake manually . <p>To release:</p> <ul style="list-style-type: none">► Apply and then release the electric parking brake manually. <p>If it is not possible to apply the electric parking brake or the red  indicator lamp continues to flash:</p> <ul style="list-style-type: none">► Do not continue driving under any circumstances. Consult a qualified specialist workshop.► Where necessary, also safeguard the parked vehicle against rolling away. <p>The yellow  indicator lamp is lit and the red  indicator lamp flashes for approximately ten seconds after the electric parking brake has been applied or released. It then remains lit or goes out. The electric parking brake is malfunctioning.</p> <p>If the battery charge level is too low:</p> <ul style="list-style-type: none">► Charge the battery. <p>To apply:</p> <ul style="list-style-type: none">► Switch off the ignition. The electric parking brake is applied automatically.

Display messages	Possible causes/consequences and ► Solutions
	<p>If the electric parking brake should not be applied, e.g. when washing the vehicle in an automatic car wash or when having the vehicle towed, leave the ignition switched on. Do not do this when having the vehicle towed with the rear axle raised.</p> <p>If the electric parking brake is not applied automatically:</p> <ul style="list-style-type: none">► Switch off the ignition and switch it back on.► Release and then apply the electric parking brake manually . <p>If it is still not possible to apply the electric parking brake:</p> <ul style="list-style-type: none">► Consult a qualified specialist workshop.► Where necessary, also safeguard the parked vehicle against rolling away. <p>To release:</p> <ul style="list-style-type: none">► If the conditions for automatic release are fulfilled and the electric parking brake is not released automatically, release the electric parking brake manually . <p>If it is still not possible to release the electric parking brake:</p> <ul style="list-style-type: none">► Do not continue driving under any circumstances. Consult a qualified specialist workshop.

Display messages	Possible causes/consequences and ► Solutions
 <p data-bbox="118 298 404 325">Check brake fluid level</p>	<p data-bbox="527 182 1275 209">* There is insufficient brake fluid in the brake fluid reservoir.</p> <div data-bbox="553 236 1984 493" style="border: 1px solid gray; padding: 5px;"> <p data-bbox="574 246 1344 273">▲ WARNING Risk of an accident due to low brake fluid level</p> <p data-bbox="574 296 1815 323">If the brake fluid level is too low, the braking effect and the braking characteristics may be impaired.</p> <ul style="list-style-type: none"> <li data-bbox="574 339 1902 401">▶ Pull over and stop the vehicle safely as soon as possible, paying attention to road and traffic conditions. Do not continue driving under any circumstances. <li data-bbox="574 418 1111 480">▶ Consult a qualified specialist workshop. Do not top up the brake fluid. </div> <ul style="list-style-type: none"> <li data-bbox="553 515 1974 578">▶ Pull over and stop the vehicle safely as soon as possible, paying attention to road and traffic conditions. Do not continue driving under any circumstances. <li data-bbox="553 594 1085 656">▶ Consult a qualified specialist workshop. Do not top up the brake fluid.
 <p data-bbox="118 785 404 812">Check brake pad wear</p>	<p data-bbox="527 672 1099 699">* The brake pads have reached the wear limit.</p> <ul style="list-style-type: none"> <li data-bbox="553 715 1085 742">▶ Consult a qualified specialist workshop.
 <p data-bbox="118 947 261 974">Inoperative</p>	<p data-bbox="527 835 1657 861">* At least one of the main functions of the Mercedes me connect system is malfunctioning.</p> <ul style="list-style-type: none"> <li data-bbox="553 878 1085 905">▶ Consult a qualified specialist workshop.

Display messages	Possible causes/consequences and ► Solutions
<p>Mercedes me connect Services limited See Owner's Manual</p>	<p>* Service limited. At least one of the main functions of the Mercedes me connect system is malfunctioning.</p> <ul style="list-style-type: none"> ► Observe the notes on the diagnostics connection . ► Consult a qualified specialist workshop.
<p>Active Brake Assist Functions limited See Owner's Manual</p>	<p>* Vehicles with Driving Assistance Package: Active Brake Assist with cross-traffic function, Evasive Steering Assist or PRE-SAFE® PLUS is malfunctioning. Vehicles without Driving Assistance Package: Active Brake Assist is malfunctioning.</p> <ul style="list-style-type: none"> ► Consult a qualified specialist workshop.
<p>Active Brake Assist Functions currently limited See Owner's Manual</p>	<p>* Vehicles with the Driving Assistance Package: Active Brake Assist with cross-traffic function, Evasive Steering Assist or PRE-SAFE® PLUS are temporarily unavailable or only partially available. Vehicles without the Driving Assistance package: Active Brake Assist is temporarily unavailable. The ambient conditions are outside the system borders .</p> <ul style="list-style-type: none"> ► Drive on. As soon as the ambient conditions are within the system borders, the system will become available again. ► If the display message does not disappear, stop the vehicle while paying attention to road and traffic conditions and restart the engine.
<p>PRE-SAFE inoperative See Owner's Manual</p>	<p>* PRE-SAFE® functions are malfunctioning.</p> <ul style="list-style-type: none"> ► Consult a qualified specialist workshop.



Display messages	Possible causes/consequences and ► Solutions
 <p>Restraint sys. malfunction Consult workshop</p>	<p>* The restraint system is faulty .</p> <p>▲ WARNING Risk of injury or fatal injury due to a malfunction in the restraint system</p> <p>If the restraint system is malfunctioning, restraint system components may be triggered unintentionally or might not be triggered at all in the event of an accident. This may affect the seat belt tensioner or airbag, for example.</p> <p>► Have the restraint system checked and repaired immediately at a qualified specialist workshop.</p> <p>Detection of a restraint system malfunction:</p> <ul style="list-style-type: none">• the  restraint system warning lamp does not light up when the ignition is switched on.• the  restraint system warning lamp lights up continuously or repeatedly during a journey. <p>► Consult a qualified specialist workshop immediately.</p>

Display messages	Possible causes/consequences and ► Solutions
 <p>Front left malfunction Consult workshop (example)</p>	<p>* The corresponding restraint system is malfunctioning .</p> <p>▲ WARNING Risk of injury or fatal injury due to a malfunction in the restraint system</p> <p>If the restraint system is malfunctioning, restraint system components may be triggered unintentionally or might not be triggered at all in the event of an accident. This may affect the seat belt tensioner or airbag, for example.</p> <p>► Have the restraint system checked and repaired immediately at a qualified specialist workshop.</p> <p>Detection of a restraint system malfunction:</p> <ul style="list-style-type: none"> • the  restraint system warning lamp does not light up when the ignition is switched on. • the  restraint system warning lamp lights up continuously or repeatedly during a journey. <p>► Consult a qualified specialist workshop immediately.</p>
 <p>Left windowbag malfunction Consult workshop (example)</p>	<p>* The corresponding windowbag is malfunctioning .</p> <p>▲ WARNING Risk of injury or fatal injury due to a malfunction in the window airbag</p> <p>The window airbag might be triggered unintentionally or might not be triggered at all in the event of an accident with high deceleration.</p> <p>► Have the window airbag checked and repaired immediately at a qualified specialist workshop.</p> <p>► Consult a qualified specialist workshop immediately.</p>

Display messages	Possible causes/consequences and ► Solutions
<p>Front-passenger airbag disabled See Owner's Manual</p>	<p>* The front passenger airbag is disabled, even though an adult or a person with a build corresponding to that of an adult is seated on the front passenger seat. If additional forces are applied to the seat, the weight the system detects may be too low.</p> <p>▲ WARNING - Risk of injury or even fatal injury when the front passenger airbag is disabled</p> <p>If the front passenger airbag is disabled, It will not be deployed in the event of an accident and cannot perform its intended protective function.</p> <p>A person in the front passenger seat could then, for example, come into contact with the vehicle interior, especially if the person is sitting too close to the dashboard.</p> <p>► Be aware of the status of the front passenger airbag both before and during the journey.</p> <ul style="list-style-type: none">► Pull over and stop the vehicle safely as soon as possible, paying attention to road and traffic conditions.► Check the status of the automatic front passenger airbag shutoff .► If necessary, consult a qualified specialist workshop immediately.



Display messages	Possible causes/consequences and ► Solutions
<p>Front-passenger airbag enabled See Owner's Manual</p>	<p>* The front passenger airbag is enabled while the vehicle is in motion:</p> <ul style="list-style-type: none">• even when a child, a small adult or an object weighing less than the system weight threshold is located on the front passenger seat• even when the front passenger seat is not occupied <p>The system may detect objects or forces that are adding to the weight applied to the seat.</p> <p>⚠ WARNING Risk of injury or fatal injury when using a child restraint system while the front passenger airbag is enabled</p> <p>If you secure a child in a child restraint system on the front passenger seat and the front passenger airbag is enabled, the front passenger airbag can deploy in the event of an accident.</p> <p>The child could be struck by the airbag.</p> <p>► Ensure, both before and during the journey, that the status of the front passenger airbag is correct.</p> <p>NEVER use a rearward facing child restraint on a seat protected by an ACTIVE FRONT AIRBAG in front of it; DEATH or SERIOUS INJURY to the CHILD can occur.</p> <ul style="list-style-type: none">► Pull over and stop the vehicle safely as soon as possible, paying attention to road and traffic conditions.► Check the status of the automatic front passenger airbag shutoff .► If necessary, consult a qualified specialist workshop immediately.



Driving systems

Display messages	Possible causes/consequences and ► Solutions
 <p data-bbox="118 350 461 410">ATTENTION ASSIST: Take a break!</p>	<ul style="list-style-type: none"> <li data-bbox="527 236 1835 296">* ATTENTION ASSIST has detected fatigue or an increasing lack of concentration on the part of the driver (→ page 211). <li data-bbox="547 308 923 339">► If necessary, take a break.
 <p data-bbox="118 547 461 607">ATTENTION ASSIST inoperative</p>	<ul style="list-style-type: none"> <li data-bbox="527 433 1017 464">* ATTENTION ASSIST is malfunctioning. <li data-bbox="547 476 1087 507">► Consult a qualified specialist workshop.
<p data-bbox="118 632 461 726">Active Lane Keeping Assist currently unavailable See Owner's Manual</p>	<ul style="list-style-type: none"> <li data-bbox="527 622 1418 695">* Active Lane Keeping Assist is temporarily unavailable. The ambient conditions are outside the system borders (→ page 219). <li data-bbox="547 707 1905 769">► Drive on. As soon as the ambient conditions are within the system borders, the system will become available again.
<p data-bbox="118 798 461 858">Active Lane Keeping Assist inoperative</p>	<ul style="list-style-type: none"> <li data-bbox="527 788 1111 819">* Active Lane Keeping Assist is malfunctioning. <li data-bbox="547 831 1087 862">► Consult a qualified specialist workshop.

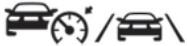

Display messages	Possible causes/consequences and ► Solutions
Blind Spot Assist currently unavailable See Owner's Manual	<p>* Blind Spot Assist is temporarily unavailable. The system borders have been reached (→ page 216).</p> <ul style="list-style-type: none"> ► Drive on. Once the cause of the problem is no longer present, the system will be available again. <p>or</p> <ul style="list-style-type: none"> ► If the display message does not disappear, stop the vehicle while paying attention to road and traffic conditions and restart the engine. ► If necessary, clean the rear bumper. If the bumper is extremely dirty, the sensors in the bumper may be malfunctioning.
Active Blind Spot Assist currently unavailable See Owner's Manual	<p>* Active Blind Spot Assist is temporarily unavailable. The system borders have been reached (→ page 216).</p> <ul style="list-style-type: none"> ► Drive on. Once the cause of the problem is no longer present, the system will be available again. ► If the display message does not disappear, stop the vehicle while paying attention to road and traffic conditions and restart the engine.
Blind Spot Assist not available when towing a trailer See Owner's Manual	<p>* When you establish the electrical connection to the trailer, Blind Spot Assist is unavailable.</p> <ul style="list-style-type: none"> ► Press the left-hand touch control and acknowledge the display message.

Display messages	Possible causes/consequences and ► Solutions
Active Blind Spot Assist not available when towing a trailer See Owner's Manual	<ul style="list-style-type: none"> * When you establish the electrical connection to the trailer, Active Blind Spot Assist is unavailable. <ul style="list-style-type: none"> ► Press the left-hand touch control and acknowledge the display message.
Blind Spot Assist inoperative	<ul style="list-style-type: none"> * Blind Spot Assist is malfunctioning. <ul style="list-style-type: none"> ► Consult a qualified specialist workshop.
Active Blind Spot Assist inoperative	<ul style="list-style-type: none"> * Active Blind Spot Assist is malfunctioning. <ul style="list-style-type: none"> ► Consult a qualified specialist workshop.
Active Parking Assist and PARKTRONIC inoperative See Owner's Manual	<ul style="list-style-type: none"> * Active Parking Assist and Parking Assist PARKTRONIC are malfunctioning. <ul style="list-style-type: none"> ► Stop the vehicle, paying attention to road and traffic conditions, and restart the engine. ► If the display message continues to be displayed, consult a qualified specialist workshop.
Traffic Sign Assist currently unavailable See Owner's Manual	<ul style="list-style-type: none"> * Traffic Sign Assist is temporarily unavailable. <ul style="list-style-type: none"> ► Drive on. Once the cause of the problem is no longer present, the system will be available again.
Traffic Sign Assist inoperative	<ul style="list-style-type: none"> * Traffic Sign Assist is malfunctioning. <ul style="list-style-type: none"> ► Consult a qualified specialist workshop.

Display messages	Possible causes/consequences and ► Solutions
 <p>Off</p>	<ul style="list-style-type: none"> * The HOLD function is deactivated because the vehicle is skidding or a condition for activation is not met. <ul style="list-style-type: none"> ► Reactivate the HOLD function later or check the activation conditions for the HOLD function .
<p>Active Distance Assist available again</p>	<ul style="list-style-type: none"> * Active Distance Assist DISTRONIC is operational again and can be activated (→ page 184).
 <p>--- mph</p>	<ul style="list-style-type: none"> * Active Distance Assist DISTRONIC cannot be activated as not all activation conditions have been fulfilled. <ul style="list-style-type: none"> ► Comply with the activation conditions of Active Distance Assist DISTRONIC .

Display messages	Possible causes/consequences and ► Solutions
  Currently unavailable Radar sensors dirty	<p>* The radar sensor system is malfunctioning. Possible causes:</p> <ul style="list-style-type: none">• soiling of the sensors• heavy rain• extended country driving without other traffic, e.g. in the desert <p>Driving systems and driving safety systems may be malfunctioning or temporarily unavailable. Once the cause of the problem is no longer present, driving systems and driving safety systems will become available again.</p> <p>If the display message does not disappear:</p> <ul style="list-style-type: none">► Pull over and stop the vehicle safely, paying attention to road and traffic conditions.► Clean all sensors .► Restart the engine.



Display messages	Possible causes/consequences and ► Solutions
 <p>Currently unavailable Camera dirty</p>	<p>* The camera view is restricted. Possible causes:</p> <ul style="list-style-type: none"> • dirt on the windscreen in the camera's field of vision • heavy rain, snow or fog <p>Driving systems and driving safety systems may be malfunctioning or temporarily unavailable. Once the cause of the problem is no longer present, driving systems and driving safety systems will become available again.</p> <p>If the display message does not disappear:</p> <ul style="list-style-type: none"> ► Pull over and stop the vehicle safely, paying attention to road and traffic conditions. ► Clean the windscreen.
<p>Active Distance Assist currently unavailable See Owner's Manual</p>	<p>* Active Distance Assist DISTRONIC is temporarily unavailable. The ambient conditions are outside the system borders (→ page 183).</p> <ul style="list-style-type: none"> ► Drive on. As soon as the ambient conditions are within the system borders, the system will become available again.
<p>Active Distance Assist inoperative</p>	<p>* Active Distance Assist DISTRONIC is malfunctioning. Other driving and driving safety systems may also be malfunctioning.</p> <ul style="list-style-type: none"> ► Consult a qualified specialist workshop.

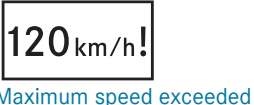

Display messages	Possible causes/consequences and ► Solutions
 <p data-bbox="118 298 466 391">Active Steering Assist currently unavailable See Owner's Manual</p>	<ul style="list-style-type: none"> <li data-bbox="527 184 1420 256">* Active Steering Assist is temporarily unavailable. The ambient conditions are outside the system borders (→ page 188). <li data-bbox="547 267 1911 334">► Drive on. As soon as the ambient conditions are within the system borders, the system will become available again.
 <p data-bbox="118 526 466 588">Active Steering Assist inoperative</p>	<ul style="list-style-type: none"> <li data-bbox="527 412 1712 443">* Active Steering Assist is malfunctioning. Active Distance Assist DISTRONIC remains available. <li data-bbox="547 453 1089 484">► Consult a qualified specialist workshop.
<p data-bbox="118 614 308 645">Limiter passive</p>	<ul style="list-style-type: none"> <li data-bbox="527 603 1978 666">* If you depress the accelerator pedal beyond the pressure point (kickdown), the limiter is switched to passive mode (→ page 181).
 <p data-bbox="343 738 435 769">--- mph</p>	<ul style="list-style-type: none"> <li data-bbox="527 681 1518 712">* Cruise control cannot be activated as not all activation conditions are fulfilled. <li data-bbox="547 723 1252 754">► Observe the activation conditions for cruise control .
<p data-bbox="118 821 339 852">Cruise control off</p>	<ul style="list-style-type: none"> <li data-bbox="527 811 1825 914">* Cruise control has been deactivated. If there is an additional warning tone, cruise control has been switched off automatically (→ page 179) (→ page 179).



Display messages	Possible causes/consequences and ► Solutions
Cruise control inoperative	<ul style="list-style-type: none"> * Cruise control is malfunctioning. <ul style="list-style-type: none"> ► Consult a qualified specialist workshop.
Cruise control and Limiter inoperative	<ul style="list-style-type: none"> * Cruise control and the limiter are malfunctioning. <ul style="list-style-type: none"> ► Consult a qualified specialist workshop.
Limiter inoperative	<ul style="list-style-type: none"> * The limiter is malfunctioning. <ul style="list-style-type: none"> ► Consult a qualified specialist workshop.
	<ul style="list-style-type: none"> * The limiter cannot be activated as not all activation conditions have been fulfilled. <ul style="list-style-type: none"> ► Observe the activation conditions of the limiter .
Speed limit (winter tyres) XXX mph	<ul style="list-style-type: none"> * You have reached the stored maximum speed for winter tyres. It is not possible to exceed this speed.
	<ul style="list-style-type: none"> * The maximum permissible speed has been exceeded (only for certain countries). <ul style="list-style-type: none"> ► Drive more slowly.



Engine



Display messages	Possible causes/consequences and ► Solutions
<p>Top up coolant See Owner's Manual</p>	<p>* The coolant level is too low.</p> <div data-bbox="553 288 1984 394" style="border: 1px solid black; padding: 5px;"> <p>! NOTE Engine damage due to insufficient coolant</p> <p>► Avoid long journeys with insufficient coolant.</p> </div> <p>► Add coolant .</p>
<div data-bbox="128 464 324 567" style="border: 1px solid black; padding: 5px; text-align: center;">  </div> <p>Coolant Stop vehicle Switch engine off</p>	<p>* The coolant is too hot.</p> <p>► Stop the vehicle immediately, paying attention to road and traffic conditions, and switch off the engine.</p> <div data-bbox="553 567 1984 791" style="border: 1px solid black; padding: 5px;"> <p>! WARNING Danger of burns when opening the bonnet</p> <p>If you open the engine bonnet when the engine has overheated or during a fire in the engine compartment, you could come into contact with hot gases or other escaping operating fluids.</p> <p>► Before opening the bonnet, allow the engine to cool down.</p> <p>► In the event of a fire in the engine compartment, keep the engine bonnet closed and call the fire service.</p> </div> <p>► Wait until the engine has cooled down.</p> <p>► Make sure that the air supply to the radiator is not obstructed.</p> <p>► Avoiding high loads on the engine, drive on to the nearest qualified specialist workshop. In doing so, ensure that the coolant temperature display remains below 120 °C.</p>



Display messages	Possible causes/consequences and ► Solutions
 <p data-bbox="53 298 314 325">See Owner's Manual</p>	<p data-bbox="466 180 899 211">* The battery is not being charged.</p> <div data-bbox="490 236 1921 385" style="border: 1px solid gray; padding: 5px;"> <p data-bbox="515 246 1230 277">! NOTE Possible engine damage if you continue driving</p> <ul style="list-style-type: none"> <li data-bbox="515 298 1173 329">▶ Do not continue driving under any circumstances. <li data-bbox="515 339 1050 370">▶ Consult a qualified specialist workshop. </div> <ul style="list-style-type: none"> <li data-bbox="486 406 1815 437">▶ Stop the vehicle immediately, paying attention to road and traffic conditions, and switch off the engine. <li data-bbox="486 447 1026 478">▶ Consult a qualified specialist workshop.
 <p data-bbox="53 615 376 671">Start engine See Owner's Manual</p>	<p data-bbox="466 495 1181 526">* The engine is off and the battery charge level is too low.</p> <ul style="list-style-type: none"> <li data-bbox="486 536 1197 567">▶ Switch off electrical consumers that are not required. <li data-bbox="486 578 1447 644">▶ Leave the engine running for a few minutes, or drive for a longer distance. The battery charges.



Display messages	Possible causes/consequences and ► Solutions
 <p data-bbox="118 298 439 360">Stop vehicle See Owner's Manual</p>	<p data-bbox="527 182 1516 213">* The battery is no longer being charged and the battery charge level is too low.</p> <div data-bbox="553 236 1984 387" style="border: 1px solid black; padding: 5px;"> <p data-bbox="578 246 1291 277">! NOTE Possible engine damage if you continue driving</p> <ul style="list-style-type: none"> <li data-bbox="578 298 1236 329">▶ Do not continue driving under any circumstances. <li data-bbox="578 339 1109 370">▶ Consult a qualified specialist workshop. </div> <ul style="list-style-type: none"> <li data-bbox="553 407 1978 469">▶ Pull over and stop the vehicle safely as soon as possible, paying attention to road and traffic conditions. Do not continue driving under any circumstances. <li data-bbox="553 484 868 515">▶ Switch off the engine. <li data-bbox="553 526 1089 557">▶ Consult a qualified specialist workshop.
 <p data-bbox="118 686 445 749">Stop vehicle Leave engine running</p>	<p data-bbox="527 570 985 601">* The battery charge level is too low.</p> <ul style="list-style-type: none"> <li data-bbox="553 617 1978 679">▶ Pull over and stop the vehicle safely as soon as possible, paying attention to road and traffic conditions. Do not continue driving under any circumstances. <li data-bbox="553 689 915 721">▶ Leave the engine running. <li data-bbox="553 731 1371 762">▶ Wait until the display message disappears before pulling away.





Display messages	Possible causes/consequences and ► Solutions
 <p data-bbox="53 298 359 362">Check eng. oil lev. when next refuelling</p>	<p data-bbox="466 180 1165 213">* The engine oil level has dropped to the minimum level.</p> <div data-bbox="490 236 1921 343" style="border: 1px solid black; padding: 5px;"> <p data-bbox="515 246 1398 279">! NOTE Engine damage caused by driving with insufficient engine oil</p> <p data-bbox="515 298 1140 331">► Avoid long journeys with insufficient engine oil.</p> </div> <p data-bbox="486 362 1120 395">► Check the engine oil level when next refuelling.</p> <p data-bbox="486 414 932 447">Top up the engine oil (→ page 378).</p> <p data-bbox="486 457 915 491">Notes on engine oil (→ page 437).</p>
 <p data-bbox="53 623 376 687">Engine oil level Stop vehicle Switch engine off</p>	<p data-bbox="466 505 1005 538">* Display message only for certain engines: The engine oil level is too low.</p> <div data-bbox="490 602 1921 710" style="border: 1px solid black; padding: 5px;"> <p data-bbox="515 613 1398 646">! NOTE Engine damage caused by driving with insufficient engine oil</p> <p data-bbox="515 665 1140 698">► Avoid long journeys with insufficient engine oil.</p> </div> <p data-bbox="486 727 1913 793">► Pull over and stop the vehicle safely as soon as possible, paying attention to road and traffic conditions. Do not continue driving under any circumstances.</p> <p data-bbox="486 803 805 837">► Switch off the engine.</p> <p data-bbox="486 847 862 880">► Check the engine oil level.</p> <p data-bbox="486 899 932 932">Top up the engine oil (→ page 378).</p> <p data-bbox="486 942 915 975">Notes on engine oil (→ page 437).</p>

Display messages	Possible causes/consequences and ► Solutions
 <p data-bbox="118 298 445 360">Engine oil level Reduce oil level</p>	<p data-bbox="527 184 1071 256">* Display message only for certain engines: The engine oil level is too high.</p> <div data-bbox="553 280 1984 387" style="border: 1px solid black; padding: 5px;"> <p data-bbox="574 291 1406 322">! NOTE Engine damage caused by driving with excess engine oil</p> <p data-bbox="574 342 1150 373">► Avoid long journeys with excess engine oil.</p> </div> <p data-bbox="547 408 1704 439">► Consult a qualified specialist workshop immediately and have the engine oil siphoned off.</p>
 <p data-bbox="118 570 451 632">Add 1 litre engine oil when next refuelling</p>	<p data-bbox="527 456 1228 529">* Display message only for certain engines: The engine oil level has dropped to the minimum level.</p> <div data-bbox="553 550 1984 656" style="border: 1px solid black; padding: 5px;"> <p data-bbox="574 560 1459 591">! NOTE Engine damage caused by driving with insufficient engine oil</p> <p data-bbox="574 612 1203 643">► Avoid long journeys with insufficient engine oil.</p> </div> <p data-bbox="547 677 1181 708">► Check the engine oil level when next refuelling.</p> <p data-bbox="547 729 993 760">Top up the engine oil (→ page 378).</p> <p data-bbox="547 770 977 801">Notes on engine oil (→ page 437).</p>

Display messages	Possible causes/consequences and ► Solutions
 <p data-bbox="53 298 359 363">Engine oil pressure Stop Switch off engine</p>	<p data-bbox="466 182 1007 256">* Display message only for certain engines: The engine oil pressure is too low.</p> <div data-bbox="492 277 1923 386" style="border: 1px solid black; padding: 5px;"> <p data-bbox="513 291 1508 322">! NOTE Engine damage caused by driving with insufficient engine oil pressure</p> <p data-bbox="513 339 1255 370">► Avoid long journeys with insufficient engine oil pressure.</p> </div> <p data-bbox="486 407 1913 513">► Pull over and stop the vehicle safely as soon as possible, paying attention to road and traffic conditions. Do not continue driving under any circumstances. ► Consult a qualified specialist workshop.</p>
 <p data-bbox="53 644 374 706">Engine oil level cannot be measured</p>	<p data-bbox="466 530 1631 602">* The electrical connection to the oil level sensor is interrupted or the oil level sensor is faulty. The engine oil level has dropped to the minimum level.</p> <p data-bbox="486 613 1024 644">► Consult a qualified specialist workshop.</p>
 <p data-bbox="53 839 294 870">Clean the fuel filter</p>	<p data-bbox="466 725 1749 756">* Vehicles with diesel engines: the fuel filter is dirty or the water in the fuel filter must be drained off.</p> <p data-bbox="486 766 1024 797">► Consult a qualified specialist workshop.</p>

Display messages	Possible causes/consequences and ► Solutions
 <p data-bbox="118 298 359 327">Replace air cleaner</p>	<ul style="list-style-type: none"> * Vehicles with diesel engines: the engine air filter is dirty and must be replaced. <ul style="list-style-type: none"> ► Consult a qualified specialist workshop.
 <p data-bbox="118 461 339 490">Reserve fuel level</p>	<ul style="list-style-type: none"> * The fuel supply has dropped into the reserve range. <ul style="list-style-type: none"> ► Refuel.
<p data-bbox="118 515 421 578">Antriebssystem Störung Anhalten Motor aus</p>	<ul style="list-style-type: none"> * The drive system is malfunctioning. <ul style="list-style-type: none"> ► Stop the vehicle immediately, paying attention to road and traffic conditions, and switch off the engine. ► Consult a qualified specialist workshop.
<p data-bbox="118 647 421 709">Antriebssystem Störung Werkstatt aufsuchen</p>	<ul style="list-style-type: none"> * The drive system is malfunctioning. <ul style="list-style-type: none"> ► Consult a qualified specialist workshop.
	<ul style="list-style-type: none"> * The fan motor is defective. <ul style="list-style-type: none"> ► Avoiding high loads on the engine, drive on to the nearest qualified specialist workshop. In doing so, ensure that the coolant temperature display remains below 120 °C.



Display messages	Possible causes/consequences and ► Solutions
 <p>Top up AdBlue Perf. reduced in XXX miles See Owner's Manual</p>	<ul style="list-style-type: none"> * The low AdBlue® level will lead to limited performance after the remaining distance displayed has been driven. <ul style="list-style-type: none"> ► Refill AdBlue® immediately . ⓘ The message disappears after driving at a speed above 15 km/h for approximately one minute.
 <p>Top up AdBlue Perf. reduced: XXX mph No start in XXX miles</p>	<ul style="list-style-type: none"> * The low AdBlue® level will lead to limited performance as of the speed displayed. After the displayed remaining distance has been covered, it will no longer be possible to start the engine. <ul style="list-style-type: none"> ► Refill AdBlue® immediately.
 <p>AdBlue system fault Perf. reduced: XXX mph No start in XXX miles</p>	<ul style="list-style-type: none"> * Power reduction due to the AdBlue® system fault. After the distance displayed has been covered, it will no longer be possible to start the engine. <ul style="list-style-type: none"> ► Consult a qualified specialist workshop immediately.

Display messages	Possible causes/consequences and ► Solutions
 <p>AdBlue system fault Engine start not possible</p>	<ul style="list-style-type: none"> * The AdBlue® system is malfunctioning. You can no longer start the engine. <ul style="list-style-type: none"> ► Consult a qualified specialist workshop immediately.
 <p>AdBlue system fault Perf. reduced in XXX miles See Owner's Manual</p>	<ul style="list-style-type: none"> * The AdBlue® system is malfunctioning. Performance will be reduced after the remaining distance displayed has been covered. <ul style="list-style-type: none"> ► Consult a qualified specialist workshop immediately.
 <p>AdBlue system fault See Owner's Manual</p>	<ul style="list-style-type: none"> * The AdBlue® system is malfunctioning. <ul style="list-style-type: none"> ► Consult a qualified specialist workshop immediately.
 <p>Refill AdBlue See Owner's Manual</p>	<ul style="list-style-type: none"> * The AdBlue® level has fallen below the reserve range. <ul style="list-style-type: none"> ► Refill AdBlue® immediately .

Display messages	Possible causes/consequences and ► Solutions
 <p data-bbox="53 298 392 362">Refill AdBlue Eng. start not possible</p>	<ul style="list-style-type: none"><li data-bbox="457 184 1269 218">* The AdBlue® tank is empty. You can no longer start the engine.<ul style="list-style-type: none"><li data-bbox="488 232 938 266">► Top up at least 4.5 l of AdBlue® .<li data-bbox="488 276 1265 340">► Switch the ignition on. You can restart the engine after approximately one minute.

Tyres

Display messages	Possible causes/consequences and ► Solutions
Tyre pressure Check tyres	<p>* The tyre pressure loss warning system has detected a significant loss in pressure.</p> <p>▲ WARNING Risk of an accident due to insufficient tyre pressure</p> <p>Tyres with insufficient tyre pressure pose the following risks:</p> <ul style="list-style-type: none"> • The tyres may burst, especially as the load and vehicle speed increase. • The tyres may wear excessively and/or unevenly, which may greatly impair tyre traction. • - The driving characteristics, steering and braking may be greatly impaired. <p>You could then lose control of the vehicle.</p> <ul style="list-style-type: none"> ► Observe the recommended tyre pressures. ► Adjust the tyre pressure if necessary. <ul style="list-style-type: none"> ► Stop the vehicle, paying attention to road and traffic conditions. ► Check the tyre pressure and the tyres. ► When the tyre pressure is correct, restart the tyre pressure loss warning system .
Check tyre pressures then restart Run Flat Indicator	<p>* The tyre pressure loss warning system generated a display message and has not been restarted since.</p> <ul style="list-style-type: none"> ► When the tyre pressure is correct, restart the tyre pressure loss warning system .
Run Flat Indicator inoperative	<p>* The tyre pressure loss warning system is malfunctioning.</p> <ul style="list-style-type: none"> ► Consult a qualified specialist workshop.

Display messages	Possible causes/consequences and ► Solutions
 <p data-bbox="53 298 314 329">Rectify tyre pressure</p>	<p data-bbox="466 184 1892 246">* The tyre pressure is too low in at least one of the tyres, or the tyre pressure difference between the wheels is too great.</p> <ul style="list-style-type: none"> <li data-bbox="486 256 1148 288">► Check the tyre pressure and add air, if necessary. <li data-bbox="486 298 1516 329">► When the tyre pressure is correct, restart the tyre pressure monitoring system .
 <p data-bbox="53 464 220 495">Check tyre(s)</p>	<p data-bbox="466 346 1688 377">* The tyre pressure in one or more tyres has dropped significantly. The wheel position is displayed.</p> <div data-bbox="492 401 1923 449" style="background-color: #e0e0e0; padding: 5px;"> <p data-bbox="513 412 1349 443">▲ WARNING Risk of an accident due to insufficient tyre pressure</p> </div> <p data-bbox="506 464 1263 495">Tyres with insufficient tyre pressure pose the following risks:</p> <ul style="list-style-type: none"> <li data-bbox="519 505 1434 536">• The tyres may burst, especially as the load and vehicle speed increase. <li data-bbox="519 547 1647 578">• The tyres may wear excessively and/or unevenly, which may greatly impair tyre traction. <li data-bbox="519 588 1479 619">• - The driving characteristics, steering and braking may be greatly impaired. <p data-bbox="506 644 1030 675">You could then lose control of the vehicle.</p> <ul style="list-style-type: none"> <li data-bbox="506 685 1087 716">► Observe the recommended tyre pressures. <li data-bbox="506 727 1017 758">► Adjust the tyre pressure if necessary. <ul style="list-style-type: none"> <li data-bbox="486 795 1324 826">► Stop the vehicle, paying attention to road and traffic conditions. <li data-bbox="486 837 1009 868">► Check the tyre pressure and the tyres.



Display messages	Possible causes/consequences and ► Solutions
 <p data-bbox="118 298 363 329">Warning tyre defect</p>	<p data-bbox="527 182 1719 213">* The tyre pressure in one or more tyres has dropped suddenly. The wheel position is displayed.</p> <div data-bbox="553 236 1984 565" style="border: 1px solid #ccc; padding: 10px;"> <p data-bbox="574 246 1351 277">▲ WARNING Risk of an accident from driving with a flat tyre</p> <p data-bbox="574 296 1150 327">Flat tyres are dangerous in the following ways:</p> <ul data-bbox="584 339 1545 412" style="list-style-type: none"> <li data-bbox="584 339 1116 370">• The tyres can overheat and cause a fire. <li data-bbox="584 381 1545 412">• - The driving characteristics, steering and braking may be greatly impaired. <p data-bbox="574 436 1095 467">You could then lose control of the vehicle.</p> <ul data-bbox="574 477 1013 550" style="list-style-type: none"> <li data-bbox="574 477 962 508">► Do not drive with a flat tyre. <li data-bbox="574 519 1013 550">► Observe the notes on flat tyres. </div> <p data-bbox="553 586 966 617">Notes on flat tyres (→ page 390).</p> <ul data-bbox="553 627 1391 700" style="list-style-type: none"> <li data-bbox="553 627 1391 658">► Stop the vehicle, paying attention to road and traffic conditions. <li data-bbox="553 669 799 700">► Check the tyres.
<p data-bbox="118 726 421 788">Tyre press. monitor currently unavailable</p>	<p data-bbox="527 715 1974 778">* No signals can be received from the tyre pressure sensors due to strong radio signal source interference. The tyre pressure monitoring system is temporarily unavailable.</p> <ul data-bbox="553 793 1841 855" style="list-style-type: none"> <li data-bbox="553 793 1841 855">► Drive on. The tyre pressure monitoring system restarts automatically as soon as the cause has been rectified.



Display messages	Possible causes/consequences and ► Solutions
 <p>Wheel sensor(s) missing</p>	<ul style="list-style-type: none"> * There is no signal from the tyre pressure sensor of one or more wheels. The pressure of the affected tyre is not displayed. <ul style="list-style-type: none"> ► Have the faulty tyre pressure sensor replaced at a qualified specialist workshop.
<p>Tyre press. monitor inoperative No wheel sensors</p>	<ul style="list-style-type: none"> * The wheels fitted do not have suitable tyre pressure sensors. The tyre pressure monitoring system is deactivated. <ul style="list-style-type: none"> ► Fit wheels with suitable tyre pressure sensors.
<p>Tyre press. monitor inoperative</p>	<ul style="list-style-type: none"> * The tyre pressure monitoring system is faulty. <div style="border: 1px solid black; padding: 10px; margin: 10px 0;"> <p>⚠ WARNING There is a risk of an accident if the tyre pressure monitoring system is malfunctioning</p> <p>If the tyre pressure monitoring system is malfunctioning, it is not able to issue a warning if there is pressure loss in one or more of the tyres.</p> <p>Tyres with insufficient tyre pressure may, for example, affect the vehicle's handling characteristics, steering and braking. -</p> <ul style="list-style-type: none"> ► Have the tyre pressure monitoring system checked at a qualified specialist workshop. </div> <ul style="list-style-type: none"> ► Consult a qualified specialist workshop.
<p>Tyre(s) overheated</p>	<ul style="list-style-type: none"> * At least one tyre is overheating. The affected tyres are displayed in red. At temperatures close to the limit value, the tyres are displayed in yellow. <ul style="list-style-type: none"> ► Drive more slowly.

Display messages	Possible causes/consequences and ► Solutions
<p>Tyre(s) overheated Reduce speed</p>	<p>* At least one tyre is overheating.</p> <div data-bbox="553 236 1984 384" style="border: 1px solid black; padding: 5px;"> <p>▲ WARNING Risk of an accident from driving with overheated tyres</p> <p>Overheated tyres may burst, particularly at high speeds.</p> <p>► Reduce speed so that the tyres cool down.</p> </div> <p>► Reduce speed so that the tyres cool down.</p>

Key

Display messages	Possible causes/consequences and ► Solutions
<div data-bbox="128 612 324 715" style="border: 1px solid black; padding: 5px;">  </div> <p>Replace key</p>	<p>* The key needs to be replaced.</p> <p>► Consult a qualified specialist workshop.</p>

Display messages	Possible causes/consequences and ► Solutions
 <p data-bbox="53 298 372 360">Replace key See Owner's Manual</p>	<p data-bbox="466 184 1725 215">* Vehicles with a digital vehicle key: only a few or no authorisations remain for starting the engine.</p> <ul style="list-style-type: none"> <li data-bbox="486 228 1606 260">► Make sure that the internet connection is not limited by certain mobile phone settings. <li data-bbox="486 270 1913 301">► Open the Mercedes me connect web app http://www.mercedes.me. and call up the digital vehicle key service. <li data-bbox="486 311 1193 342">► Deactivate the service first and then activate it again. <li data-bbox="486 353 1770 384">► If the display message still appears, contact the Mercedes-Benz Customer Assistance Center (CAC). <p data-bbox="486 389 1827 420">Vehicles with a digital vehicle key sticker: only a few or no authorisations remain for starting the engine.</p> <ul style="list-style-type: none"> <li data-bbox="486 430 1847 493">► Order a new digital vehicle key sticker from a Mercedes-Benz Service Centre or at http://www.mercedes-benz.com/connect.
 <p data-bbox="53 629 318 660">Change key batteries</p>	<p data-bbox="466 515 860 547">* The key battery is discharged.</p> <ul style="list-style-type: none"> <li data-bbox="486 557 793 588">► Replace the battery .
 <p data-bbox="53 792 359 853">Key not detected (white display message)</p>	<p data-bbox="466 678 887 709">* The key is currently undetected.</p> <ul style="list-style-type: none"> <li data-bbox="486 720 1091 751">► Change the location of the key in the vehicle. <li data-bbox="486 761 1667 792">► If the key is still not recognised, start the engine with the key in the stowage compartment .

Display messages	Possible causes/consequences and ► Solutions
 <p>Key not detected (red display message)</p>	<p>* The key cannot be detected and may no longer be in the vehicle. The key is no longer in the vehicle and you switch off the engine:</p> <ul style="list-style-type: none">• you can no longer start the engine.• you cannot centrally lock the vehicle. <p>► Ensure that the key is in the vehicle.</p> <p>If the key detection function has a malfunction due to a strong radio signal source:</p> <ul style="list-style-type: none">► Pull over and stop the vehicle safely as soon as possible, paying attention to road and traffic conditions.► Place the key in the stowage compartment for starting the engine with the key .
 <p>Place the key in the marked space See Owner's Manual</p>	<p>* The key detection function is malfunctioning.</p> <ul style="list-style-type: none">► Change the location of the key in the vehicle.► Start the vehicle with the key in the stowage compartment .

Vehicle

Display messages	Possible causes/consequences and ► Solutions
 <p>Trailer coupling extending...</p>	<ul style="list-style-type: none">* Retract or extend the ball neck. <p>Do not attempt to speed up, slow down or initiate the retracting or extending process using your hand, foot or other aids. During the retracting or extending process, do not couple a trailer.</p> <p>When the ball neck has reached an operational position, the display message disappears.</p>

Display messages



Check trailer hitch lock

Possible causes/consequences and ► Solutions

* The trailer hitch is not operational when you are driving with a trailer.

- Stop the vehicle immediately, paying attention to road and traffic conditions, and switch off the engine.
- Uncouple the trailer and safeguard it against rolling away.
- Initiate a new swivelling procedure .
- When the display message disappears, couple up the trailer and drive on.

▲ WARNING Risk of an accident if the ball neck is not locked

If the ball neck is not in the locked position, the trailer may come loose.

- Pull over and stop the vehicle safely as soon as possible, paying attention to road and traffic conditions. Do not continue driving under any circumstances.
- Uncouple the trailer and secure it against rolling away.
- Initiate a new swivelling procedure and do not re-couple the trailer until the display message disappears.

If the display message does not disappear, the trailer hitch is defective and the ball neck is not locked.

- Do not couple up the trailer. Drive on without the trailer. Note the reduced ground clearance due to the unlocked ball neck.
- Consult a qualified specialist workshop.

The trailer hitch is not operational when the vehicle is at a standstill.



- Uncouple the coupled trailer and safeguard it against rolling away.
- Initiate a new swivelling procedure .

Display messages	Possible causes/consequences and ► Solutions
	<p>If the display message does not disappear, the trailer hitch is defective and the ball neck is not locked.</p> <ul style="list-style-type: none"> ► Do not couple up the trailer. Drive on without the trailer. Note the reduced ground clearance due to the unlocked ball neck. ► Consult a qualified specialist workshop.
Apply brake to deselect Park (P) position	<p>* You have attempted to shift the transmission out of position P and into another transmission position.</p> <ul style="list-style-type: none"> ► Depress the brake pedal.
To shift out of P or N, depress brake and start engine	<p>* You have attempted to shift the transmission out of position P or N into another transmission position.</p> <ul style="list-style-type: none"> ► Depress the brake pedal. ► Start the engine.
Risk of vehicle rolling Driver door open and transmission not in P	<p>* The driver's door is not fully closed and the transmission is in position R, N or D.</p> <ul style="list-style-type: none"> ► Shift the transmission to position P when you park the vehicle.
N permanently active Risk of vehicle rolling	<p>* While the vehicle is rolling or while you are driving, the transmission has been shifted to position N.</p> <ul style="list-style-type: none"> ► Depress the brake pedal to stop and, when the vehicle is stationary, shift the transmission to position P. ► To continue your journey, shift the transmission to position D or R.
Only select Park (P) when vehicle is stationary	<p>* The transmission can be shifted to position P only when the vehicle is stationary.</p>



Display messages	Possible causes/consequences and ► Solutions
<p>Without changing gear, consult workshop</p>	<ul style="list-style-type: none"> * The transmission is malfunctioning. The transmission position can no longer be shifted. <ul style="list-style-type: none"> ► When the transmission is in position D, consult a qualified specialist workshop and do not shift the transmission position. ► For all other transmission positions, park the vehicle safely. ► Consult a qualified specialist workshop.
<div style="text-align: center;">  </div> <p>Vehicle is operational Switch off the ignition before exiting</p>	<ul style="list-style-type: none"> * You are leaving the vehicle when it is in a ready-to-drive state. <ul style="list-style-type: none"> ► When leaving the vehicle, switch off the ignition, secure the vehicle against rolling away and take the key with you. ► If you do not leave the vehicle, switch off the electrical consumers, e.g. the seat heater. Otherwise, the 12-V battery may discharge and it will then be possible to start the vehicle only using a donor battery (starting assistance).
<p>Transmission Malfunction Stop</p>	<ul style="list-style-type: none"> * The transmission is malfunctioning. The transmission shifts to position N automatically. <ul style="list-style-type: none"> ► Pull over and stop the vehicle safely as soon as possible, paying attention to road and traffic conditions. ► Switch the transmission to position P. ► Consult a qualified specialist workshop.
<p>Reversing not poss. Consult workshop</p>	<ul style="list-style-type: none"> * The transmission is malfunctioning. Reverse gear can no longer be engaged. <ul style="list-style-type: none"> ► Consult a qualified specialist workshop.



Display messages	Possible causes/consequences and ► Solutions
Auxiliary battery malfunction	<ul style="list-style-type: none"> * The auxiliary battery for the transmission is no longer being charged. <ul style="list-style-type: none"> ► Consult a qualified specialist workshop. ► Until then, always manually set the transmission to position P before you switch off the engine. ► Before leaving the vehicle, apply the electric parking brake.
Air conditioning Malfunction See Owner's Manual	<ul style="list-style-type: none"> * Operation of the climate control system is temporarily restricted. Airflow and fresh air supply are set to automatic mode. <ul style="list-style-type: none"> ► Have the climate control system checked at a qualified specialist workshop.
Getriebe Störung Werkstatt aufsuchen	<ul style="list-style-type: none"> * The transmission is malfunctioning. Consult a qualified specialist workshop.
Teaching in transmission complete	<ul style="list-style-type: none"> * The transmission's teach-in process is complete. All transmission positions can be engaged again.
Getriebe wird eingelernt Wählhebel betätigen Bremse für XX s treten Wegrollgefahr	<ul style="list-style-type: none"> * The transmission is being taught in. There is a risk of the vehicle rolling away. <ul style="list-style-type: none"> ► Depress and hold the brake pedal until the teach-in procedure has been completed. The electric parking brake is applied automatically during the teach-in procedure. ► Switch the ignition on. ► Select transmission position P, R or N.

Display messages	Possible causes/consequences and ► Solutions
<p>Trans. oil overheated Drive on with care</p>	<p>* The transmission is overheating. When the display message is active, starting up and driving characteristics may be temporarily impaired.</p> <ul style="list-style-type: none"> ► Drive at low speeds. ► Avoid sporty driving. ► Before starting up on uphill gradients, let the transmission cool down until the display message disappears.
<p>Anti-theft alarm system Malfunction</p>	<p>* The anti-theft alarm system is malfunctioning.</p> <ul style="list-style-type: none"> ► Consult a qualified specialist workshop.
<p>Apply brake to select R</p>	<p>* You have attempted to shift the transmission out of position D and into transmission position R.</p> <ul style="list-style-type: none"> ► Depress the brake pedal. ► Switch the transmission to position R.
<div data-bbox="126 612 324 715" data-label="Image"> </div> <p>Operation only possible in transmission position N</p>	<p>* You have attempted to swivel the ball neck and the transmission is not in position N.</p> <ul style="list-style-type: none"> ► Switch the transmission to position N.



Display messages	Possible causes/consequences and ► Solutions
 <p data-bbox="53 298 380 360">Operation only possible in transmission position P</p>	<ul style="list-style-type: none"> * You have attempted to swivel the ball neck and the transmission is in position R, N or D. <ul style="list-style-type: none"> ► Depress the brake pedal. ► Switch the transmission to position P.
 <p data-bbox="53 495 380 588">Steering malfunction Stop immediately See Owner's Manual</p>	<ul style="list-style-type: none"> * The steering is malfunctioning. Steering capability is considerably impaired. <div data-bbox="492 430 1923 653" style="border: 1px solid gray; padding: 5px; margin: 5px 0;"> <p>⚠ WARNING Risk of accident if steering capability is impaired</p> <p>If the steering does not function as intended, the vehicle's operating safety is jeopardised.</p> <ul style="list-style-type: none"> ► Pull over and stop the vehicle safely as soon as possible, paying attention to road and traffic conditions. Do not continue driving under any circumstances. ► Consult a qualified specialist workshop. </div> <ul style="list-style-type: none"> ► Pull over and stop the vehicle safely as soon as possible, paying attention to road and traffic conditions. Do not continue driving under any circumstances. ► Consult a qualified specialist workshop.
 <p data-bbox="53 914 380 976">Steering malfunction Drive carefully Visit workshop</p>	<ul style="list-style-type: none"> * The power assistance for the steering is malfunctioning. You may need to use more force to steer. <ul style="list-style-type: none"> ► Drive on carefully. ► Consult a qualified specialist workshop.





Display messages	Possible causes/consequences and ► Solutions
<p>Let fresh air into the vehicle interior! Air conditioning malf. Visit workshop</p>	<p>* The climate control system is malfunctioning.</p> <p>▲ WARNING Risk of injury and accident due to an insufficient supply of fresh air</p> <p>If the climate control system is malfunctioning, carbon dioxide levels may increase in the passenger compartment. Breathing in carbon dioxide may cause dizziness.</p> <p>► Open the window to ensure that there is a sufficient supply of fresh air.</p> <p>► Open the window to ensure that there is an adequate supply of fresh air.</p> <p>► Consult a qualified specialist workshop immediately.</p>
 <p>Steering malfunction Increased physical effort See Owner's Manual</p>	<p>* The power assistance for the steering is malfunctioning.</p> <p>▲ WARNING Risk of an accident due to altered steering characteristics</p> <p>If the power assistance of the steering fails partially or completely, you will need to use more force to steer.</p> <p>► If safe steering is possible, drive on carefully.</p> <p>► Visit or consult a qualified specialist workshop immediately.</p> <p>► If safe steering is possible, drive on carefully.</p> <p>► Visit or consult a qualified specialist workshop immediately.</p>
<p>Active bonnet malfunction See Owner's Manual</p>	<p>* The active bonnet (pedestrian protection) is malfunctioning or inoperative after having already been triggered.</p> <p>► Consult a qualified specialist workshop.</p>

Display messages	Possible causes/consequences and ► Solutions
	<p>* The bonnet is open.</p> <div style="background-color: #f0f0f0; padding: 5px; margin: 5px 0;"> <p>▲ WARNING Risk of accident due to driving with the engine bonnet unlocked</p> <p>An unlocked engine bonnet may open up when the vehicle is in motion and block your view.</p> <ul style="list-style-type: none"> ▶ Never unlock the engine bonnet when driving. ▶ Before every trip, ensure that the engine bonnet is locked. </div> <ul style="list-style-type: none"> ▶ Pull over and stop the vehicle safely as soon as possible. ▶ Close the bonnet.
	<p>* At least one door is open.</p> <ul style="list-style-type: none"> ▶ Close all doors.

Display messages	Possible causes/consequences and ► Solutions
	<p>* The tailgate is open.</p> <p>▲ WARNING Risk of exhaust gas poisoning</p> <p>Combustion engines emit poisonous exhaust gases such as carbon monoxide. Exhaust gases can enter the vehicle interior if the tailgate is open when the engine is running, especially if the vehicle is in motion.</p> <ul style="list-style-type: none">▶ Always switch off the engine before opening the tailgate.▶ Never drive with the tailgate open. <p>▶ Close the tailgate.</p>
 <p>Top up washer fluid</p>	<p>* The washer fluid level in the washer fluid reservoir has dropped below the minimum.</p> <p>▶ Top up the washer fluid .</p>

Lights

Display messages	Possible causes/consequences and ► Solutions
 <p data-bbox="57 350 404 381">Left dipped beam (example)</p>	<ul style="list-style-type: none"> <li data-bbox="466 236 1030 263">* The corresponding light source is defective. <li data-bbox="486 277 1030 304">► Consult a qualified specialist workshop. <p data-bbox="486 346 519 366">or</p> <ul style="list-style-type: none"> <li data-bbox="486 381 1406 408">► Check whether you are permitted to replace the light source yourself . <li data-bbox="486 422 1923 484">ⓘ LED light bulbs: the display message for the corresponding lamp appears only when all the light-emitting diodes in the lamp have failed.
 <p data-bbox="57 621 404 673">Active Light System inoperative</p>	<ul style="list-style-type: none"> <li data-bbox="466 505 887 532">* The active headlamps are faulty. <li data-bbox="486 547 1030 573">► Consult a qualified specialist workshop.
 <p data-bbox="57 816 355 868">Intelligent Light System inoperative</p>	<ul style="list-style-type: none"> <li data-bbox="466 700 1882 762">* The Intelligent Light System is faulty. The lighting system continues to function properly without the functions of the Intelligent Light System. <li data-bbox="486 777 1030 803">► Consult a qualified specialist workshop.

Display messages	Possible causes/consequences and ► Solutions
 <p data-bbox="118 298 433 360">Malfunction See Owner's Manual</p>	<ul style="list-style-type: none"> <li data-bbox="523 184 911 215">* The exterior lighting is faulty. <ul style="list-style-type: none"> <li data-bbox="553 225 1089 256">► Consult a qualified specialist workshop. <li data-bbox="553 260 1228 291">Vehicles with a trailer hitch: a fuse may have blown. <li data-bbox="553 301 1882 332">► Pull over and stop the vehicle safely as soon as possible, paying attention to road and traffic conditions. <li data-bbox="553 342 1193 373">► Check the fuses and replace them if necessary .
 <p data-bbox="118 508 410 539">AUTO lights inoperative</p>	<ul style="list-style-type: none"> <li data-bbox="523 394 860 425">* The light sensor is faulty. <ul style="list-style-type: none"> <li data-bbox="553 436 1089 467">► Consult a qualified specialist workshop.
 <p data-bbox="118 671 318 702">Switch off lights</p>	<ul style="list-style-type: none"> <li data-bbox="523 553 1324 584">* You are leaving the vehicle and the lights are still switched on. <ul style="list-style-type: none"> <li data-bbox="553 594 1116 625">► Turn the light switch to the AUTO position.
 <p data-bbox="118 829 384 860">Switch on headlamps</p>	<ul style="list-style-type: none"> <li data-bbox="523 715 1156 746">* You are driving without dipped-beam headlamps. <ul style="list-style-type: none"> <li data-bbox="553 757 1222 788">► Turn the light switch to the  or AUTO position.
<p data-bbox="118 881 445 950">Adaptive Highbeam Assist Plus inoperative</p>	<ul style="list-style-type: none"> <li data-bbox="523 878 1048 909">* Adaptive Highbeam Assist Plus is faulty. <ul style="list-style-type: none"> <li data-bbox="553 919 1089 951">► Consult a qualified specialist workshop.

Display messages	Possible causes/consequences and ► Solutions
Adaptive Highbeam Assist Plus currently unavailable See Owner's Manual	<ul style="list-style-type: none"> * Adaptive Highbeam Assist Plus is temporarily unavailable. The system borders have been reached (→ page 122). <ul style="list-style-type: none"> ► Drive on. Once the cause of the problem is no longer present, the system will be available again. The Adaptive Highbeam Assist Plus available again display message appears.
Adaptive Highbeam Assist inoperative	<ul style="list-style-type: none"> * Adaptive Highbeam Assist is malfunctioning. <ul style="list-style-type: none"> ► Consult a qualified specialist workshop.
Adaptive Highbeam Assist currently unavailable See Owner's Manual	<ul style="list-style-type: none"> * Adaptive Highbeam Assist is temporarily unavailable. The system borders have been reached (→ page 121). <ul style="list-style-type: none"> ► Drive on. Once the cause of the problem is no longer present, the system will be available again. The Adaptive Highbeam Assist available again display message appears.

Warning and indicator lamps

Overview of warning and indicator lamps

Some systems perform a self-test when the ignition is switched on. Some warning and indicator lamps may briefly light up or flash. This behaviour is non-critical. These warning and indicator lamps indicate a malfunction only if they light up

or flash after the engine is started or during a journey.

Instrument display (standard)















Instrument display in the widescreen cockpit



The positions of the indicator lamps on the instrument display may differ from the sample display depending on the display setting.

Warning and indicator lamps:

-  Dipped beam (→ page 116)
-  Standing lights (→ page 116)
-  Main beam (→ page 118)
-  Turn signal light (→ page 118)
-  Rear fog light (→ page 116)
-  Seat belt not fastened (→ page 504)
-  Brakes (red) (→ page 498)
-  Brakes (yellow) (→ page 498)
-  ABS malfunctioning (→ page 498)
-  ESP® (→ page 498)
-  ESP® OFF (→ page 498)
-  Electric parking brake (→ page 498)
-  Power-assisted steering malfunctioning (→ page 506)



Electrical fault (→ page 508)



Restraint system (→ page 498)



Engine diagnostics (→ page 508)



Fuel reserve with fuel filler cap location indicator (→ page 508)



Vehicles with widescreen cockpit: coolant too hot/cold (→ page 508)



Distance warning (→ page 505)



Preglow



Tyre pressure monitoring system (→ page 511)



Trailer hitch is not operational or swivels (→ page 506)

Safety systems

Warning/indicator lamp	Possible causes/consequences and ► Solutions
 <p data-bbox="53 350 400 412">Brake system warning lamp (yellow)</p>	<p data-bbox="439 233 1324 264">The yellow brake system warning lamp is lit while the engine is running.</p> <div data-bbox="439 284 1921 476"><p data-bbox="453 295 1330 326">▲ WARNING Risk of an accident due to a brake system malfunction</p><p data-bbox="459 347 1438 378">If the brake system is malfunctioning, braking characteristics may be impaired.</p><ul data-bbox="459 388 1488 461" style="list-style-type: none"><li data-bbox="459 388 727 419">► Drive on carefully.<li data-bbox="459 429 1488 461">► Have the brake system checked immediately at a qualified specialist workshop.</div> <ul data-bbox="439 492 1712 611" style="list-style-type: none"><li data-bbox="439 492 1712 523">► Adjust your speed and continue to drive carefully, leaving a suitable distance to the vehicle in front.<li data-bbox="439 533 1398 564">► If the multifunction display shows a display message, please observe this.<li data-bbox="439 574 977 611">► Consult a qualified specialist workshop.

Warning/indicator lamp

Brake system warning lamp
(red)

Possible causes/consequences and ► Solutions

The red brake system warning lamp is lit while the engine is running.

Possible causes:

- The brake force boosting is malfunctioning and the braking characteristics may be affected.
- There is insufficient brake fluid in the brake fluid reservoir.

▲ WARNING There is a risk of an accident if brake force boosting is malfunctioning

If brake force boosting is malfunctioning, increased brake pedal force may be necessary for braking. Braking characteristics may be impaired. The braking distance may increase in an emergency braking situation.



- Pull over and stop the vehicle safely as soon as possible, paying attention to road and traffic conditions. Do not continue driving under any circumstances.
- Consult a qualified specialist workshop.

▲ WARNING Risk of an accident due to low brake fluid level

If the brake fluid level is too low, the braking effect and the braking characteristics may be impaired.

- Pull over and stop the vehicle safely as soon as possible, paying attention to road and traffic conditions. Do not continue driving under any circumstances.
- Consult a qualified specialist workshop.
Do not top up the brake fluid.

Warning/indicator lamp	Possible causes/consequences and ► Solutions
	<ul style="list-style-type: none"> ► Pull over and stop the vehicle safely as soon as possible, paying attention to road and traffic conditions. Do not continue driving under any circumstances. ► Observe the messages on the multifunction display. ► Consult a qualified specialist workshop.
<div style="text-align: center;">  <p>ABS warning lamp</p> </div>	<p>The yellow ABS warning lamp is lit while the engine is running. ABS is malfunctioning.</p> <p>If there is an additional acoustic warning signal, EBD is malfunctioning. Other driving systems and driving safety systems may also be faulty.</p> <div style="background-color: #e0e0e0; padding: 5px; margin: 10px 0;"> <p>▲ WARNING There is risk of skidding if EBD or ABS is malfunctioning</p> </div> <p>If EBD or ABS is malfunctioning, the wheels could lock when braking The steering capability and braking characteristics are thus severely impaired. The braking distance may increase in an emergency braking situation. In addition, other driving safety systems are switched off.</p> <ul style="list-style-type: none"> ► Drive on carefully. ► Have the brake system checked immediately at a qualified specialist workshop. <ul style="list-style-type: none"> ► Drive on carefully. ► Observe the messages in the multifunction display. ► Consult a qualified specialist workshop.

Warning/indicator lamp	Possible causes/consequences and ► Solutions
 <p>ESP® warning lamp flashes</p>	<p>The yellow ESP® warning lamp flashes while the vehicle is in motion. ESP® is intervening .</p> <ul style="list-style-type: none"> ► Adapt your driving style to suit the road and weather conditions.
 <p>ESP® warning lamp lights up</p>	<p>The yellow ESP® warning lamp is lit while the engine is running. ESP® is malfunctioning. Other driving and driving safety systems may also be faulty.</p> <div style="background-color: #e0e0e0; padding: 5px; margin-bottom: 10px;"> <p>⚠ WARNING Risk of skidding if ESP® is malfunctioning</p> </div> <p>If ESP® is malfunctioning, ESP® cannot carry out vehicle stabilisation. In addition, other driving safety systems are switched off.</p> <ul style="list-style-type: none"> ► Drive on carefully. ► Have ESP® checked at a qualified specialist workshop. <ul style="list-style-type: none"> ► Drive on carefully. ► Observe the messages in the multifunction display. ► Consult a qualified specialist workshop.

Warning/indicator lamp



ESP[®] OFF warning lamp

Possible causes/consequences and ► Solutions

The yellow ESP[®] OFF warning lamp is lit while the engine is running.
ESP[®] is deactivated.

▲ WARNING Risk of skidding when driving with ESP[®] deactivated



If ESP[®] is deactivated, ESP[®] cannot carry out vehicle stabilisation. The availability of further driving safety systems is also limited.

- ▶ Drive on carefully.
- ▶ Only deactivate ESP[®] for as long as the situation requires.

If ESP[®] cannot be activated, ESP[®] is malfunctioning.

- ▶ Have ESP[®] checked immediately at a qualified specialist workshop.

- ▶ Observe the notes on deactivating ESP[®] .

Warning/indicator lamp	Possible causes/consequences and ► Solutions
 <p data-bbox="118 298 461 363">Red indicator lamp, electric parking brake applied</p>  <p data-bbox="118 481 461 570">Yellow electric parking brake indicator lamp is malfunctioning</p>	<p data-bbox="500 182 1972 241">The red electric parking brake indicator lamp flashes or is lit. The yellow indicator lamp is also lit if the electric parking brake malfunctions.</p> <ul data-bbox="500 256 1181 288" style="list-style-type: none"><li data-bbox="500 256 1181 288">► Observe the messages in the multifunction display.

Warning/indicator lamp	Possible causes/consequences and ► Solutions
 <p data-bbox="57 298 372 360">Restraint system warning lamp</p>	<p data-bbox="439 181 1324 256">The red restraint system warning lamp is lit while the engine is running. The restraint system is malfunctioning.</p> <div data-bbox="439 277 1917 458"><p data-bbox="455 288 1545 322">▲ WARNING Risk of injury or fatal injury due to a malfunction in the restraint system</p><p data-bbox="459 339 1902 405">If the restraint system is malfunctioning, restraint system components may be triggered unintentionally or might not be triggered at all in the event of an accident. This may affect the seat belt tensioner or airbag, for example.</p><p data-bbox="459 415 1688 449">► Have the restraint system checked and repaired immediately at a qualified specialist workshop.</p></div> <ul data-bbox="439 479 1136 592" style="list-style-type: none"><li data-bbox="439 479 707 513">► Drive on carefully.<li data-bbox="439 524 1116 558">► Observe the messages in the multifunction display.<li data-bbox="439 568 1136 592">► Consult a qualified specialist workshop immediately.

Seat belt

Warning/indicator lamp	Possible causes/consequences and ► Solutions
 <p data-bbox="57 887 343 950">Seat belt warning lamp lights up</p>	<p data-bbox="439 770 1275 846">The red seat belt warning lamp lights up after the engine is started. In addition, an acoustic warning tone may sound.</p> <p data-bbox="439 856 1582 890">The seat belt warning lamp reminds the driver and front passenger to fasten their seat belts.</p> <ul data-bbox="439 901 752 929" style="list-style-type: none"><li data-bbox="439 901 752 929">► Fasten your seat belt. <p data-bbox="439 953 1649 982">If you have placed objects on the front passenger seat, the seat belt warning lamp may remain lit.</p>

Warning/indicator lamp	Possible causes/consequences and ► Solutions
 <p data-bbox="118 298 408 360">Seat belt warning lamp flashes</p>	<p data-bbox="502 182 1502 213">The red seat belt warning lamp flashes and an intermittent warning tone sounds.</p> <p data-bbox="502 223 1631 254">The driver or front passenger has not fastened their seat belt while the vehicle is in motion.</p> <ul data-bbox="502 265 1177 376" style="list-style-type: none"><li data-bbox="502 265 817 296">► Fasten your seat belt.<li data-bbox="502 301 1079 332">There are objects on the front passenger seat.<li data-bbox="502 342 1177 376">► Remove the objects from the front passenger seat.

Driving systems

Warning/indicator lamp	Possible causes/consequences and ► Solutions
 <p data-bbox="118 663 441 725">Distance warning warning lamp</p>	<p data-bbox="502 547 1371 578">The red distance warning lamp lights up while the vehicle is in motion.</p> <p data-bbox="502 588 1371 619">The distance to the vehicle in front is too small for the speed selected.</p> <p data-bbox="502 629 1631 660">If there is an additional warning tone, you are approaching an obstacle at too high a speed.</p> <ul data-bbox="502 671 972 749" style="list-style-type: none"><li data-bbox="502 671 972 702">► Be prepared to brake immediately.<li data-bbox="502 712 819 749">► Increase the distance. <p data-bbox="502 769 748 800">Active Brake Assist.</p>

Vehicle

Warning/indicator lamp



Trailer hitch warning lamp

Possible causes/consequences and ► Solutions

The red trailer hitch warning lamp is on.

The trailer hitch is not operational or swivels.

▲ WARNING Risk of an accident if the ball neck is not locked

If the ball neck is not in the locked position, the trailer may come loose.

- Pull over and stop the vehicle safely as soon as possible, paying attention to road and traffic conditions. Do not continue driving under any circumstances.
- Uncouple the trailer and secure it against rolling away.
- Initiate a new swivelling procedure and do not re-couple the trailer until the display message disappears.

► Observe the messages in the multifunction display.

If the trailer hitch swivels:

- Wait until the ball neck has reached the operational position.

Warning/indicator lamp

Power steering system
warning lamp

Possible causes/consequences and ► Solutions

The red power steering system warning lamp is lit while the engine is running.
The power steering assistance or the steering itself is malfunctioning.



▲ WARNING Risk of accident if steering capability is impaired

If the steering does not function as intended, the vehicle's operating safety is jeopardised.

- Pull over and stop the vehicle safely as soon as possible, paying attention to road and traffic conditions. Do not continue driving under any circumstances.
- Consult a qualified specialist workshop.

► Observe the messages in the multifunction display.

Engine

Warning/indicator lamp	Possible causes/consequences and ► Solutions
 <p data-bbox="51 350 378 409">Engine diagnosis warning lamp</p>	<p data-bbox="439 233 1849 347">The yellow engine diagnostics warning lamp is lit while the engine is running. A malfunction has occurred in the engine, the exhaust system or the fuel system. The emissions limit value may have been exceeded and the engine may be running in emergency operation mode.</p> <ul style="list-style-type: none"> <li data-bbox="439 357 1481 388">► Have the vehicle checked as soon as possible at a qualified specialist workshop. <p data-bbox="439 393 1297 424">Vehicles with a diesel engine: the fuel tank may have been run dry.</p> <ul style="list-style-type: none"> <li data-bbox="439 435 1900 528">► Start the engine three to four times after refuelling. If the yellow engine diagnostics warning lamp goes out, emergency operation mode is cancelled. The vehicle need not be checked.
 <p data-bbox="51 668 378 694">Fuel reserve warning lamp</p>	<p data-bbox="439 549 1308 621">The yellow fuel reserve warning lamp is lit while the engine is running. The fuel supply has dropped into the reserve range.</p> <ul style="list-style-type: none"> <li data-bbox="439 631 572 663">► Refuel.
 <p data-bbox="51 828 337 885">Electrical fault warning lamp</p>	<p data-bbox="439 709 960 782">The red electrical fault warning lamp is lit. There is a fault in the electrics.</p> <ul style="list-style-type: none"> <li data-bbox="439 792 1113 823">► Observe the messages in the multifunction display.

Warning/indicator lamp

Coolant warning lamp

Possible causes/consequences and ► Solutions

The red coolant warning lamp is lit while the engine is running.

Possible causes:

- The temperature sensor is malfunctioning
- Coolant level too low
- The air supply to the radiator is obstructed
- The radiator fan is faulty

If there is an additional warning tone, the coolant temperature has exceeded 120 °C.

▲ WARNING Danger of burns when opening the bonnet

If you open the engine bonnet when the engine has overheated or during a fire in the engine compartment, you could come into contact with hot gases or other escaping operating fluids.

- ▶ Before opening the bonnet, allow the engine to cool down.
- ▶ In the event of a fire in the engine compartment, keep the engine bonnet closed and call the fire service.

- ▶ Stop the vehicle immediately, paying attention to road and traffic conditions, and switch off the engine. Do not continue driving under any circumstances.
- ▶ Observe the messages in the multifunction display.

If the coolant temperature display is at the lower end of the temperature scale:

- ▶ Consult a qualified specialist workshop.

Warning/indicator lamp	Possible causes/consequences and ► Solutions
	<p>Otherwise:</p> <ul style="list-style-type: none"><li data-bbox="437 215 1651 246">► Leave the vehicle and keep a safe distance from the vehicle until the engine has cooled down.<li data-bbox="437 256 784 288">► Check the coolant level.<li data-bbox="437 298 1259 329">► Make sure that the air supply to the radiator is not obstructed.<li data-bbox="437 339 1929 409">► Avoiding high loads on the engine, drive on to the nearest qualified specialist workshop. In doing so, ensure that the coolant temperature display remains below 120 °C.

Tyres

Warning/indicator lamp	Possible causes/consequences and ► Solutions
 <p>Tyre pressure monitoring system warning lamp lights up</p>	<p>The yellow tyre pressure monitoring system warning lamp (pressure loss/malfunction) is lit. The tyre pressure monitoring system has detected tyre pressure loss in at least one of the tyres.</p> <p>▲ WARNING Risk of an accident due to insufficient tyre pressure</p> <p>Tyres with insufficient tyre pressure pose the following risks:</p> <ul style="list-style-type: none"> • The tyres may burst, especially as the load and vehicle speed increase. • The tyres may wear excessively and/or unevenly, which may greatly impair tyre traction. • - The driving characteristics, steering and braking may be greatly impaired. <p>You could then lose control of the vehicle.</p> <ul style="list-style-type: none"> ► Observe the recommended tyre pressures. ► Adjust the tyre pressure if necessary. <p>► Stop the vehicle, paying attention to road and traffic conditions.</p> <p>► Check the tyre pressure and the tyres.</p>

Warning/indicator lamp



Tyre pressure monitoring system warning lamp flashes

Possible causes/consequences and ► Solutions

The yellow tyre pressure monitoring system warning lamp (pressure loss/malfunction) flashes for approximately one minute and then remains lit.

The tyre pressure monitoring system is faulty.

▲ WARNING There is a risk of an accident if the tyre pressure monitoring system is malfunctioning

If the tyre pressure monitoring system is malfunctioning, it is not able to issue a warning if there is pressure loss in one or more of the tyres.

Tyres with insufficient tyre pressure may, for example, affect the vehicle's handling characteristics, steering and braking. -

► Have the tyre pressure monitoring system checked at a qualified specialist workshop.

► Consult a qualified specialist workshop.

- 1, 2, 3 ...**
 - 12 V battery** 400
 - Replacing 400
 - 12 V socket**
 - see Socket (12 V)
 - 230 V socket**
 - see Socket (230 V)
 - 360° Camera** 202
 - Care 384
 - Function 202
 - Selecting a view 205
 - Setting as a favourite 205
- A**
- A/C function**
 - Activating/deactivating (multimedia system) 136
 - Switching on/off (control panel) 136
 - ABS (Anti-lock Braking System)** 169
 - Acceleration**
 - see Kickdown
 - Access data**
 - Setting 353
 - Acoustic locking verification signal**
 - Activating/deactivating 65
 - Active Blind Spot Assist** 216
 - Activating/deactivating 219
 - Brake application 217
 - Function 216
 - System limitations 216
 - Trailer operation 217
 - Active bonnet (pedestrian protection)** .. 375
 - Operation 375
 - Resetting 375
 - Active Brake Assist**
 - Function/notes 174
 - Setting 178
 - Active Distance Assist DISTRONIC** 183
 - Active Emergency Stop Assist 192
 - Active Lane Change Assist 190
 - Calling up a speed 184
 - Displays in the Instrument Display 192
 - Function 183
 - Increasing/decreasing speed 184
 - Requirements: 184
 - Route-based speed adaptation 187
 - Selecting 184
 - Steering wheel buttons 184
 - Storing a speed 184
 - Switching off/deactivating 184
 - Switching on/activating 184
 - System limitations 183
 - Active Emergency Stop Assist** 192
 - Active headlamps function** 119
 - Active Lane Change Assist**
 - Activating/deactivating 192
 - Function 190
 - Active Lane Keeping Assist** 219
 - Activating/deactivating 220
 - Function 219
 - Sensitivity (function/notes) 221
 - Setting the sensitivity 221
 - System limitations 219
 - Active Parking Assist** 205
 - Cross Traffic Alert 210
 - Drive Away Assist 209
 - Exiting a parking space 208
 - Function 205
 - Parking 207
 - System limitations 205

- Active Speed Limit Assist** 186, 216
 - Display 186
 - Function 186
 - Setting 216
- Active Steering Assist** 188
 - Activating/deactivating 190
 - Active Emergency Stop Assist 192
 - Active Lane Change Assist 190
 - Displays in the Instrument Display 192
 - Function 188
 - System limitations 188
- Adaptive brake lights** 178
- Adaptive cruise control**
 - see Active Distance Assist DISTRONIC
- Adaptive functions, MULTIBEAM LED**
 - see Intelligent Light System
- Adaptive Highbeam Assist**
 - Activating/deactivating 122
 - Function 121
- Adaptive Highbeam Assist Plus**
 - Activating/deactivating 123
 - Function 122
- AdBlue®** 436
 - Additives 436
 - Filling capacity 437
 - Notes 157
 - Purity 436
 - Topping up 158
- Additional door lock** 68
 - Additives** 437
 - AdBlue 436
 - Engine oil 437
 - Fuelling 434
 - Additives (AdBlue®)**
 - see AdBlue®
 - Additives (engine oil)**
 - see Additives
 - Additives (fuel)**
 - see Fuelling
- Address book**
 - see Contacts
- Adjusting the balance/fader**
 - Burmester® surround sound system 373
- Adjusting the headlamp range** 117
- Adjusting the sound focus**
 - Burmester® surround sound system 373
- Advanced sound system**
 - Calling up the sound menu 373
 - Information 373
- After-sales service centre**
 - see ASSYST PLUS
- Air conditioning menu**
 - Calling up 136
- Air conditioning system**
 - see Climate control
- Air distribution** 135
 - Setting (multimedia system) 137
- Air vents** 138
 - Adjusting (front) 138
 - Adjusting (rear) 139
- Air vents**
 - see Air vents
- Air-recirculation mode** 138
- Airbag** 37
 - Activation 31
 - Front airbag (driver, front passenger) 37
 - Installation locations 37

- Knee airbag 37
- Overview 37
- Protection 37
- Reduced protection 39
- Side impact airbag 37
- Windowbag 37
- Airflow** 135
- Alarm**
 - see Panic alarm
- Alarm system**
 - see ATA (anti-theft alarm system)
- Alternative route**
 - see Route
- Ambient lighting** 124
- Android Auto** 343
 - Connecting a mobile phone 344
 - Ending 345
 - Note 344
 - Overview 343
 - Sound settings 345
 - Transferred vehicle data 345
- Animals**
 - Pets in the vehicle 62
- Anti-lock braking system**
 - see ABS (Anti-lock Braking System)
- Anti-skid chains**
 - see Snow chains
- Anti-theft alarm system**
 - see ATA (anti-theft alarm system)
- Anti-theft protection**
 - Additional door lock 68
 - Immobiliser 83
- Anti-theft protection**
 - see ATA (anti-theft alarm system)
- Anticipatory occupant protection**
 - see PRE-SAFE® (anticipatory occupant protection)
 - see PRE-SAFE® PLUS (anticipatory occupant protection plus)
- Apple CarPlay™** 342
 - Connecting an iPhone® 343
 - Exiting 343
 - Notes 342
 - Overview 342
 - Tone settings 343
 - Transferred vehicle data 345
- Ashtray** 110
- Assistance systems**
 - see Driving safety system
- Assistant display**
 - Menu (on-board computer) 233
- ASSYST PLUS** 374
 - Battery disconnection periods 375
 - Displaying the service due date 374
 - Function/notes 374
 - Regular maintenance work 374
 - Special service requirements 374
- ATA (anti-theft alarm system)** 83
 - Activating/deactivating interior protection 85
 - Deactivating the alarm 84
 - Function 83
 - Function of interior protection 85
 - Priming/deactivating tow-away protection 84
 - Tow-away protection function 84
- ATTENTION ASSIST** 211, 213
 - Function 211
 - Setting 213
 - System limitations 211

Attention assistant

see ATTENTION ASSIST

Authorised workshop

see Qualified specialist workshop

Automatic distance control

see Active Distance Assist DISTRONIC

Automatic driving lights 117**Automatic engine start (ECO start/stop function)** 147**Automatic engine stop (ECO start/stop function)** 147**Automatic front passenger front airbag deactivation system** 39, 41

Function of the automatic front passenger front airbag deactivation system 39

PASSENGER AIR BAG indicator lamp 41

Automatic front passenger front airbag deactivation system

see Automatic front passenger front airbag deactivation system

Automatic mirror folding function

Activating/deactivating 133

Automatic transmission

DIRECT SELECT lever 150

Drive program display 149

Drive programs 149

DYNAMIC SELECT switch 149

Engaging drive position 152

Engaging reverse gear 152

Kickdown 153

Manual gearshifting 152

Selecting park position 152

Shifting to neutral 152

Steering wheel gearshift paddles 152

Transmission position display 150

Transmission positions 150

Axle load

Permissible 431

Trailer operation 442

B**Bag hook** 106**Ball neck**

Folding in/out 221

BAS (Brake Assist System) 169**Battery**

Charging (Remote Online) 144

Key 66

Battery (vehicle)

Charging 397

Notes 395

Starting assistance 397

Belt

see Seat belt

Bicycle rack

Trailer operation 224

Blind Spot Assist 216

Activating/deactivating 219

Function 216

System limitations 216

Blower

see Climate control

BlueTEC

see AdBlue®

Bluetooth®

Activating/deactivating 283

Setting up an Internet connection 353

Settings 283

Boot lid

see Tailgate

Brake Assist System

see BAS (Brake Assist System)

Brake fluid

Notes 438

Brake force distribution

EBD (Electronic Brake force Distribution) 173

Brakes

ABS (Anti-lock Braking System) 169

Active Brake Assist 174

Adaptive brake lights 178

BAS (Brake Assist System) 169

Driving tips 145

EBD (Electronic Brake force Distribution) 173

HOLD function 194

Limited braking effect (salt-treated roads) 145

New/replaced brake linings/brake discs 145

Running-in notes 145

Braking assistance

see BAS (Brake Assist System)

Breakdown

Assistance overview 16

Tow-starting 404

Towing away 401

Transporting the vehicle 403

Wheel change 422

Breakdown

see Flat tyre

Burmester® surround sound system 372

Adjusting the balance/fader 373

Adjusting the sound focus 373

Adjusting treble, mid-range and bass settings 372

Automatic volume adjustment 373

Calling up the sound menu 372

Information 372

Switching the surround sound on/off 373

Buttons

Steering wheel 228

C**Call list**

Making a call 338, 339

Options in the call list 338

Overview 338

Calling up the sound menu

Burmester® surround sound system 372

Calls 333

Accepting 333

Activating functions during a call 333

Calls with several participants 334

Declining 333

Ending a call 333

Incoming call during an existing call 334

Making 333

Camera

see 360° Camera

see Reversing camera

Car key

see Key

Car wash

see Care

Car wash (care) 381

Car-to-X-Communication

Displaying hazard warnings	318
Overview	317
Sending hazard warnings	318

Care

Car wash	381
Carpet	386
Display	386
EASY-PACK boot box	386
Exhaust pipes	384
Exterior lighting	384
High-pressure cleaner	381
Matt finish	383
Paintwork	383
Plastic trim	386
Real wood/trim elements	386
Reversing camera/360° Camera	384
Roof lining	386
Seat belt	386
Seat cover	386
Sensors	384
Trailer tow hitch	384
Washing by hand	382
Wheels/rims	384
Windows	384

Wiper blades	384
--------------------	-----

Carpet (Care)**Changing bulbs**

Dipped beam	127
Fitting/removing cover (front wheel arch)	126
Main beam	127
Notes	125
Overview	126
Reversing lights	127
Turn signal lights (rear)	127

Changing hub caps**Changing the lights**

Driving abroad (symmetrical dipped beam)	116
--	-----

Channel tracking

Setting	371
---------------	-----

Charging

Battery (vehicle)	397
Mobile phone (wireless)	113
USB port	113

Chassis

Damping characteristics	195
-------------------------------	-----

DYNAMIC BODY CONTROL	195
----------------------------	-----

Child safety lock

Rear side windows	62
-------------------------	----

Child seat







Attaching (notes)	53
Front passenger seat (notes)	51
Front passenger seat (rearward-facing/forward-facing)	52
Front passenger seat (without airbag shutoff)	52
ISOFIX/i-Size (fitting)	49
Notes	45
Recommendations for child restraint systems	59
Seats suitable for belt-secured child restraint systems	54
Seats suitable for i-Size child restraint systems	58
Seats suitable for ISOFIX child restraint systems	56
Top Tether	50

















Child seat























see i-Size child seat securing system
see ISOFIX child seat securing system























- Child-safety lock**
 - Rear door 61
- Children**
 - Restraint systems 45
- Chock** 421
 - Storage location 421
- Cigarette lighter**
 - Front centre console 111
- City lighting** 120
- Cleaning**
 - see Care
- Climate control** 135
 - Activating/deactivating the A/C function (control panel) 136
 - Activating/deactivating the A/C function (multimedia system) 136
 - Activating/deactivating the synchronisation function (control panel) 137
 - Activating/deactivating the synchronisation function (multimedia system) 137
 - Air distribution settings 137
 - Air-recirculation mode 138
 - Automatic control 136
 - Demisting the windscreen 135
 - Demisting windows 137
 - Front air vents 138
 - Rear air vents 139
 - Residual heat 138
 - Setting (multimedia system) 136
 - Setting the air distribution 135
 - Setting the airflow 135
 - Setting the temperature 135
 - Switching on/off 136
 - Switching the rear window heater on/off 135
 - THERMATIC control panel 135
 - THERMOTRONIC control panel 135
 - Ventilating the vehicle (convenience opening) 76
- Cockpit** 6
 - Overview 6
- Combination switch**
 - see Turn signal light
- Compass** 325
- Computer**
 - On-board computer 229
- Connection status**
 - Displaying 355
 - Overview 355
- Contacts** 334
 - Calling up 335
 - Deleting 337
 - Deleting favourites 337
 - Downloading (from mobile phone) 335
 - Importing 336
 - Information 334
 - Making a call 336
 - Name format 335
 - Options 336
 - Saving a contact as a favourite 337
 - Selecting options for suggestions 337
 - Storing 336
- Convenience closing** 77
- Convenience opening** 76
- Coolant (engine)**
 - Level check 379
 - Notes 438
- Cooling**
 - see Climate control
- Copyright** 29

- Cornering light** 120
 - Cross Traffic Alert** 210
 - Crosswind Assist**
 - Function/notes 173
 - Cruise control**
 - Buttons 181
 - Calling up a speed 181
 - Requirements: 181
 - Selecting 181
 - Setting a speed 181
 - Storing a speed 181
 - Switching off 181
 - Switching on 181
 - Cruise control:** 179
 - Function 179
 - System limitations 179
 - Cup holder** 108
 - Fitting/removing (centre console) 108
 - Rear 110
- D**
- Damage detection (parked vehicle)** 167
 - Dashboard**
 - see Cockpit
 - Dashboard lighting**
 - see Instrument lighting
 - Data acquisition**
 - Vehicle 27
 - Data import/export**
 - Function/notes 286
 - Importing/exporting 286
 - Date**
 - Setting the time and date automati-
cally 282
 - Deactivating the alarm (ATA)** 84
 - Declaration of conformity**
 - Electromagnetic compatibility 23
 - Jack 23
 - TIREFIT kit 24
 - Wireless vehicle components 23
 - Designs**
 - Menu (on-board computer) 239
 - Destination** 312
 - Editing intermediate destinations 303
 - Editing the previous destinations 312
 - External 312
 - Saving (current vehicle position) 312
 - Saving as global favourite 312
 - Destination entry** 293, 296
 - Entering a POI or address 293
 - Entering an intermediate destination .. 303
 - Entering geo-coordinates 298
 - Notes 292
 - Selecting a contact 298
 - Selecting a POI 296
 - Selecting from favourites 299
 - Selecting from the map 298
 - Selecting previous destinations 296
 - Detecting inattentiveness**
 - see ATTENTION ASSIST
 - Diagnostics connection** 25
 - Diesel**
 - Low outside temperatures 435
 - Notes 435
 - Digital Car Key sticker**
 - Locking the vehicle 69
 - Unlocking the vehicle 69
 - Digital Owner's Manual** 18

- Digital speedometer** 233
- Digital Vehicle Key sticker**
Starting the vehicle 142
- Dinghy towing**
see Tow-bar system
- Dipped beam**
Activating/deactivating 116
Changing bulbs 127
Setting 123
Setting for abroad 116
- DIRECT SELECT lever** 150
Engaging drive position 152
Engaging park position automatically .. 152
Engaging reverse gear 152
Function 150
Selecting park position 152
Shifting to neutral 152
- Display**
Care 386
- Display (multimedia system)**
Home screen 258
Notes 257
Operating 260
Settings 281
- Display (on-board computer)**
Displays on the multifunction display .. 231
- Display message** 443
Calling up (on-board computer) 443
Notes 443
- Display messages**
 473, 492
 493
 492
 465
- Active Blind Spot Assist currently unavailable See Owner's Manual 460
- Active Blind Spot Assist inoperative 461
- Active Blind Spot Assist not available when towing a trailer See Owner's Manual 461
- Active bonnet malfunction See Owner's Manual 491
- Active Brake Assist Functions currently limited See Owner's Manual 454
- Active Brake Assist Functions limited See Owner's Manual 454
- Active Distance Assist available again 462
- Active Distance Assist currently unavailable See Owner's Manual 464
- Active Distance Assist inoperative 464
- Active Lane Keeping Assist currently unavailable See Owner's Manual 459
- Active Lane Keeping Assist inoperative 459
-  Active Light System inoperative .. 494
- Active Parking Assist and PARKTRONIC inoperative See Owner's Manual 461
-  Active Steering Assist currently unavailable See Owner's Manual 465
-  Active Steering Assist inoperative 465

- Adaptive Highbeam Assist currently unavailable See Owner's Manual 496
- Adaptive Highbeam Assist inoperative 496
- Adaptive Highbeam Assist Plus currently unavailable See Owner's Manual 496
- Adaptive Highbeam Assist Plus inoperative 495
-  AdBlue system fault Engine start not possible 475
-  AdBlue system fault Perf. reduced in XXX miles See Owner's Manual 475
-  AdBlue system fault See Owner's Manual 475
-  Add 1 litre engine oil when next refuelling 471
- Air conditioning Malfunction See Owner's Manual 488
- Anti-theft alarm system Malfunction ... 489
- Antriebssystem Störung Anhalten Motor aus 473
- Antriebssystem Störung Werkstatt aufsuchen 473
- Apply brake to deselect Park (P) position 486
- Apply brake to select R 489
-  ATTENTION ASSIST inoperative ... 459
-  ATTENTION ASSIST: Take a break! 459
-  AUTO lights inoperative 495
- Auxiliary battery malfunction 488
- Blind Spot Assist currently unavailable See Owner's Manual 460
- Blind Spot Assist inoperative 461
- Blind Spot Assist not available when towing a trailer See Owner's Manual ... 460
-  462
-  Change key batteries 482
-  Check brake fluid level 453
-  Check eng. oil lev. when next refuelling 470
-  Check trailer hitch lock 485
-  Check tyre(s) 478
-  Clean the fuel filter 472
-  Coolant Stop vehicle Switch engine off 467
- Cruise control and Limiter inoperative 466
- Cruise control inoperative 466
- Cruise control off 465
- Currently unavailable Camera dirty 464
- Currently unavailable Radar sensors dirty 463
-  currently unavailable See Owner's Manual 445
-  currently unavailable See Owner's Manual 446
- LIM** 466

-  Engine oil level cannot be measured 472
-  Engine oil level Reduce oil level ... 471
-  Engine oil level Stop vehicle Switch engine off 470
-  Engine oil pressure Stop Switch off engine 472
-  Front left malfunction Consult workshop (example) 456
- Front-passenger airbag disabled See Owner's Manual 457
- Front-passenger airbag enabled See Owner's Manual 458
- Getriebe Störung Werkstatt aufsuchen 488
- Getriebe wird eingelernt Wählhebel betätigen Bremse für XX s treten Wegrollgefahr 488
-  inoperative See Owner's Manual 444
-  inoperative See Owner's Manual 447
-  inoperative See Owner's Manual 448
-  Inoperative 453
-  Intelligent Light System inoperative 494
-  Key not detected (white display message) 482
-  Key not detected (red display message) 483
-  Left dipped beam (example) 494
-  Left windowbag malfunction Consult workshop (example) 456
- Let fresh air into the vehicle interior! Air conditioning malf. Visit workshop .. 491
- Limiter inoperative 466
- Limiter passive 465
-  Malfunction See Owner's Manual 495
-  Maximum speed exceeded 466
- Mercedes me connect Services limited See Owner's Manual 454
- N permanently active Risk of vehicle rolling 486
-  Off 462
- Only select Park (P) when vehicle is stationary 486
-  Operation only possible in transmission position N 489
-  Operation only possible in transmission position P 490
-  Parking brake See Owner's Manual 450
-  Place the key in the marked space See Owner's Manual 483
- PRE-SAFE inoperative See Owner's Manual 454
-  Rectify tyre pressure 478

-  Refill AdBlue Eng. start not possible 476
-  Refill AdBlue See Owner's Manual 475
-  Release parking brake 449
-  Replace air cleaner 473
-  Replace key See Owner's Manual 482
-  Replace key 481
-  Reserve fuel level 473
-  Restraint sys. malfunction Consult workshop 455
- Reversing not poss. Consult workshop 487
- Risk of vehicle rolling Driver door open and transmission not in P 486
-  See Owner's Manual 468
- Speed limit (winter tyres) XXX mph 466
-  Start engine See Owner's Manual 468
-  Steering malfunction Drive carefully Visit workshop 490
-  Steering malfunction Increased physical effort See Owner's Manual 491
-  Steering malfunction Stop immediately See Owner's Manual 490
-  Stop vehicle Leave engine running 469
-  Stop vehicle See Owner's Manual 469
-  Switch off lights 495
-  Switch on headlamps 495
- Teaching in transmission complete 488
- To shift out of P or N, depress brake and start engine 486
- Top up coolant See Owner's Manual ... 467
-  Top up washer fluid 493
- Traffic Sign Assist currently unavailable See Owner's Manual 461
- Traffic Sign Assist inoperative 461
-  Trailer coupling extending... 484
- Trans. oil overheated Drive on with care 489
- Transmission Malfunction Stop 487
-  Turn on the ignition to release the parking brake 448
- Tyre press. monitor currently unavailable 479
- Tyre press. monitor inoperative 480
- Tyre press. monitor inoperative No wheel sensors 480
- Tyre pressure Check tyres 477
- Tyre(s) overheated 480
- Tyre(s) overheated Reduce speed 481
-  Vehicle is operational Switch off the ignition before exiting 487
-  Warning tyre defect 479
-  Wheel sensor(s) missing 480
- Without changing gear, consult workshop 487

Display on the windscreen

see Head-up display

Distance control

see Active Distance Assist DISTRONIC

Distance recorder

see Trip distance

DISTRONIC

see Active Distance Assist DISTRONIC

Door

Additional door lock 68

Locking (emergency key) 72

Opening (from the inside) 69

Unlocking (emergency key) 72

Unlocking (from the inside) 69

Door control panel 14**Drawbar**

see Tow-bar system

Drinks holder

see Cup holder

Drive Away Assist 209**Drive position**

Selecting 152

Drive program display 149**Drive programs**

see DYNAMIC SELECT

Driving lights

see Automatic driving lights

Driving safety system 168

ABS (Anti-lock Braking System) 169

Active Brake Assist 174

Adaptive brake lights 178

BAS (Brake Assist System) 169

EBD (Electronic Brake force Distribu-

tion) 173

ESP® (Electronic Stability Program)

Crosswind Assist 173

ESP® (Electronic Stability Program)

trailer stabilisation 173

Overview 169

Radar sensors 168

Responsibility 168

STEER CONTROL 173

Driving system

DYNAMIC BODY CONTROL 195

Driving system

see 360° Camera

see Active Blind Spot Assist

see Active Distance Assist DISTRONIC

see Active Lane Keeping Assist

see Active Parking Assist

see Active Speed Limit Assist

see Active Steering Assist

see ATTENTION ASSIST

see Blind Spot Assist

see Cruise control:

see Driving safety system

see HOLD function

see Limiter

see Parking Assist PARKTRONIC

see Reversing camera

see Speed Limit Assist

see Traffic Sign Assist

Driving tips

Driving abroad (changing the lights) 116

General driving tips 145

Running-in notes 145

Drowsiness detection

see ATTENTION ASSIST

DYNAMIC BODY CONTROL

Chassis 195

Dynamic handling control system

see ESP® (Electronic Stability Program)

DYNAMIC SELECT	149
Configuring drive program I	150
Displaying engine data	150
Displaying vehicle data	150
Drive program display	149
Drive programs	149
Function	149
Operating (DYNAMIC SELECT switch)	149
Selecting the drive program	149

E

E10	434
Easy entry feature	
Function/notes	96
Setting	97
Easy exit feature	
Function/notes	96
Setting	97
EBD (Electronic Brake force Distribution)	
Function/notes	173

ECO display

Function	148
Resetting	234

ECO start/stop function

Automatic engine start	147
Automatic engine stop	147
Operation	147
Switching off/on	148

Electric parking brake

Applying automatically	165
Applying or releasing manually	166
Emergency braking	167
Releasing automatically	166

Electrical fuses

see Fuses

Electromagnetic compatibility

Declaration of conformity	23
---------------------------------	----

Electronic Stability Program

see ESP® (Electronic Stability Program)

Electronics**Emergency**

Assistance overview	16
Fire extinguisher	389

First-aid kit (soft sided)	389
Removing the warning triangle	388
Safety vest	388
Setting up the warning triangle	389

Emergency braking**Emergency call system**

see Mercedes-Benz emergency call system

Emergency engine start**Emergency key**

Locking a door	72
Unlocking a door	72
Unlocking the tailgate	74

Emergency key element

Inserting/removing	66
--------------------------	----

Emergency operation mode

Starting the vehicle	143
----------------------------	-----

Emergency spare wheel

Notes	427
Removing	428

Energy consumption

Key	65
-----------	----

Engine

ECO start/stop function	147
-------------------------------	-----

- Engine number 431
 - Starting (Digital Vehicle Key sticker) 142
 - Starting (emergency operation mode) 143
 - Starting (mobile phone) 142
 - Starting (Remote Online) 144
 - Starting (start/stop button) 141
 - Starting assistance 397
 - Switching off (start/stop button) 160
 - Engine bonnet**
 - Function (active bonnet) 375
 - Opening/closing 376
 - Resetting (active bonnet) 375
 - Engine data**
 - Displaying 150
 - Engine electronics**
 - Notes 429
 - Engine number** 431
 - Engine oil** 378
 - Additives 437
 - Checking the oil level using the on-board computer 378
 - Filling capacity 437
 - MB-Freigabe or MB-Approval 437
 - Quality 437
 - Topping up 378
 - Entering characters**
 - Function/notes 277
 - On the touchpad 277
 - Setting the keyboard 281
 - Using the touchscreen 279
 - ERA-GLONASS test mode**
 - Starting/ending 352
 - ESC (Electronic Stability Control)**
 - see ESP[®] (Electronic Stability Program)
 - ESP[®]**
 - Crosswind Assist 173
 - Trailer stabilisation 173
 - ESP[®] (Electronic Stability Program)** 170
 - Activating/deactivating 172
 - Function/notes 170
 - EU general operating permit number** 431
 - Exhaust pipes (Care)** 384
 - Exterior lighting**
 - Care 384
 - Exterior lighting**
 - see Lights
- F**
- Fatigue detection**
 - see ATTENTION ASSIST
 - Fault message**
 - see Display message
 - Favourites**
 - Adding 271
 - Calling up 271
 - Deleting 272
 - Moving 272
 - Overview 271
 - Renaming 271
 - Filling station search**
 - Starting an automatic filling station search 305
 - Switching the automatic filling station search on/off 304
 - Fire extinguisher** 389
 - First-aid kit (soft sided)** 389
 - Flat towing**
 - see Tow-bar system
 - Flat tyre** 390
 - MOExtended tyres 390

- Notes 390
 TIREFIT kit 391
 Wheel change 422
- Floor mats** 115
- Free software** 29
- Frequencies**
 Mobile phone 430
 Two-way radio 430
- Frequency band**
 Selecting (on-board computer) 236
- Front airbag (driver, front passenger)** 37
- Front wheel arch**
 Fitting/removing the cover 126
- Front wheel arch cover**
 Fitting/removing 126
- Fuel**
 E10 434
 Petrol 434
 Quality (petrol) 434
 Reserve fuel level 436
 Sulphur content 434
 Tank capacity 436
- Fuel consumption**
 On-board computer 233
- Fuelling** 434
 Additives 434
 Diesel 435
 Low outside temperatures 435
 Quality (diesel) 435
 Refuelling 154
- Function seat**
 see Door control panel
- Fuse insert**
 see Fuses
- Fuses** 404
 Assignment diagram 404
 Before replacing a fuse 404
 Fuse box in the engine compartment .. 405
 Fuse box in the front-passenger foot-
 well 406
 Fuse box in the load compartment 407
 Notes 404
- G**
- Garage door opener**
 Clearing the memory 163
- Opening/closing the garage door 163
 Programming buttons 161
 Radio equipment approval numbers 164
 Resolving problems 162
 Synchronising the rolling code 162
- Gearshift paddles**
 see Steering wheel gearshift paddles
- Gearshift recommendation** 153
- General operating permit number (EU)** 431
- Genuine parts** 21
- Glide mode** 154
- Global search**
 Function 274
 Overview 274
- Glove box**
 Locking/unlocking 100
- Gross weight** 431
- H**
- Handbrake**
 see Electric parking brake

- Handling characteristics (unusual)** 408
- Hazard warning lights** 119
- Head restraint** 90
 Front (adjusting manually) 90
 Rear (adjusting) 91
 Rear (fitting/removing) 92
- Head-up display** 238
 Adjusting display elements (on-board computer) 238
 Adjusting the brightness (on-board computer) 238
 Function 239
 Menu (on-board computer) 238
 Setting the position (on-board computer) 238
 Using the memory function 97
- Headlamp flasher** 118
- Heating**
 see Climate control
- High-pressure cleaner (care)** 381
- Hill Start Assist** 194
- HOLD function** 194
 Activating/deactivating 194
- Function/notes 194
- Home screen (multimedia system display)**
 Overview 258
- Hotspot**
 Setting up (Wi-Fi) 285
- I**
- i-Size child seat securing system** 47
 Fitting 49
 Notes 47
 Seats suitable for attaching 58
- Identification plate**
 Engine 431
 Vehicle 431
- Ignition**
 Switching on (Start/Stop button) 140
- Ignition key**
 see Key
- Immobiliser** 83
- Implied warranty**
 Vehicle 26
- In Car Office**
 Selecting options of Tasks & Calls 342
- Indicator lamp**
 see Warning/indicator lamps
- Individual drive program**
 Configuring 150
 Selecting 149
- Instrument cluster** 8
- Instrument cluster**
 see Instrument display
- Instrument display** 227
 Adjusting the lighting 232
 Function/notes 227
 Overview 8, 227
 Overview (standard) 8
 Overview (widescreen) 8
 Warning/indicator lamps 496
- Instrument display**
 see Instrument cluster
- Instrument lighting** 232
- Intelligent Light System** 119
 Activating/deactivating 120
 Active headlamps function 119

- Adaptive Highbeam Assist Plus 122
 - City lighting 120
 - Cornering light 120
 - Motorway mode 120
 - Overview 119
 - Interior lighting** 124
 - Ambient lighting 124
 - Setting 124
 - Switch-off delay time 125
 - Interior lighting**
 - see Interior lighting
 - see Lighting
 - see Lights
 - Interior protection**
 - Activating/deactivating 85
 - Function 85
 - Intermediate destination**
 - Calculating a route with intermediate destinations 303
 - Editing 303
 - Entering 303
 - Starting an automatic filling station search 305
 - Starting the automatic service station search 305
 - Internet**
 - Deleting a bookmark 358
 - Deleting history 358
 - Managing bookmarks 358
 - Internet connection**
 - Cancelling permission 354
 - Connection status 355
 - Displaying the connection status 355
 - Establishing 354
 - Information 352
 - Mobile phone details 354
 - Restrictions 352
 - Setting access data 353
 - Setting up (Bluetooth®) 353
 - Via Bluetooth® 353
 - Via communication module 353
 - Via Wi-Fi 353
 - Internet radio**
 - Calling up 359
 - Calling up the station list (category last selected) 361
 - Deleting stations 361
 - Logging out 361
 - Overview 360
 - Registering 361
 - Saving stations 361
 - Selecting and connecting to a station 361
 - Selecting the stream 361
 - Setting options 361
 - Terms of use 361
 - iPhone®**
 - see Apple CarPlay™
 - ISOFIX child seat securing system** 47
 - Fitting 49
 - Notes 47
 - Seats suitable for attaching 56
- J**
- Jack**
 - Declaration of Conformity 23
 - Storage location 421
 - Jump-start connection** 397
- K**
- Key** 64
 - Battery 66

- Emergency key element 66
- Energy consumption 65
- Features 64
- Key ring attachment 66
- Overview 64
- Panic alarm 65
- Problem 67
- Unlocking setting 65
- KEYLESS-GO**
- Locking the vehicle 70
- Problem 71
- Unlocking setting 65
- Unlocking the vehicle 70
- Kickdown** 153
- Using 153
- Knee airbag** 37
- L**
- Laden** 105
- Tie-down eyes 105
- Lamp (instrument display)**
- see Warning/indicator lamps
- Lamps**
- see Interior lighting
- Lane Keeping Assist**
- see Active Lane Keeping Assist
- Language**
- Notes 286
- Setting 286
- LED light**
- see Intelligent Light System
- Light switch**
- Overview 116
- Lighting** 124
- Lighting**
- see Lights
- Lights** 116, 124
- Active headlamps function 119
- Adaptive Highbeam Assist 121
- Adaptive Highbeam Assist Plus 122
- Adjusting the instrument lighting 232
- Automatic driving lights 117
- Changing bulbs 125
- City lighting 120
- Combination switch 118
- Cornering light 120
- Dipped beam 116
- Driving abroad 116
- Hazard warning lamps 119
- Headlamp flasher 118
- Headlamp range 117
- Intelligent Light System 119
- Light switch 116
- Main beam 118
- Motorway mode 120
- Parking lights 116
- Rear fog light 117
- Responsibility for lighting systems 116
- Setting the dipped beam 123
- Standing lights 116
- Turn signal light 118
- Limiters** 180
- Buttons 181
- Calling up a speed 181
- Function 180
- Passive mode 180
- Permanent setting 182
- Requirements: 181
- Selecting 181
- Setting a speed 181
- Storing a speed 181
- Switching off 181
- Switching on 181

- System limitations 180
 - Limiting speed**
see Limiter
 - LINGUATRONIC** 240
 - Application specific voice commands 242
 - Audible help functions 243
 - Entering numbers 242
 - Global voice commands 242
 - Improving speech quality 243
 - Language setting 242
 - Media player voice commands 250
 - Message voice commands 252
 - Multifunction steering wheel (operating) 240
 - Navigation voice commands 245
 - Operable functions 242
 - Operating safety 240
 - Radio voice commands 249
 - Switch voice commands 243
 - Telephone voice controls 248
 - Text message voice commands 252
 - Types of voice commands 242
 - Vehicle voice commands 253
 - Voice prompting 241
 - Live Traffic Information**
 - Displaying subscription information 314
 - Displaying the traffic map 315
 - Displaying traffic incidents 316
 - Extending a subscription 315
 - Registering on Mercedes me 314
 - Showing local area messages 317
 - Switching the traffic information display on 316
 - Load compartment cover**
Fitting/removing 103
 - Loading**
 - Bag hook 106
 - Notes 98
 - Roof rack 107
 - Stowage space underneath the load compartment floor 106
 - Loading guidelines** 98
 - Loads**
Securing 98
 - Locator lighting**
Switching on/off 124
 - Locking/unlocking** 73
 - Additional door lock 68
 - Digital Car Key sticker 69
 - KEYLESS-GO 70
 - Mobile phone 69
 - Smartphone 69
 - Unlocking/opening the doors from the inside 69
 - Lubricant additives**
see Additives
 - Luggage**
Securing 98
 - Lumbar support**
see Lumbar support (4-way)
 - Lumbar support (4-way)** 90
- M**
- Main beam**
 - Activating/deactivating 118
 - Adaptive Highbeam Assist 121
 - Adaptive Highbeam Assist Plus 122
 - Changing bulbs 127
 - Maintenance**
see ASSYST PLUS

Malfunction

Restraint system 31

Map 315, 320

Avoiding an area 323

Avoiding an area (overview) 322

Changing an area 323

Deleting an area 323

Displaying Qibla 325

Displaying the compass 325

Displaying the map version 322

Displaying the next intersecting

street 322

Displaying the satellite map 325

Displaying the traffic map 315

Displaying weather information 326

Map data 324

Moving 320

Selecting POI symbols 321

Selecting text information 322

Selecting the map orientation 321

Setting the map scale 320

Setting the map scale automatically 325

Showing in the multifunction display

of the instrument cluster 326

Showing the range 325

Switching motorway information

on/off 322

Updating 324

Massage programs

Selecting the front seats 92

Matt finish (cleaning instructions) 383**Maximum gross vehicle weight** 431**Maximum speed**

see Limiter

MBUX multimedia system 256

Overview 256

Mecca 325**Media**

Menu (on-board computer) 237

Media mode

Adding a favourite song 366

Connecting Bluetooth audio equip-

ment 365

Connecting USB devices 365

Controlling media playback 366

Copyright and trademarks 362

Information about media search 367

Making video settings 368

Overview of the media menu 364

Playing back similar music tracks 366

Removing a favourite song 366

Searching for a music track accord-

ing to mood 368

Starting media playback 366

Starting the media search 367

Supported format and data storage

media 361

Using the keyword search 368

Media playback

Operating (on-board computer) 237

Media source

Dialling (on-board computer) 237

Memory function

Head-up display – Calling up stored

settings 97

Head-up display –Storing settings 97

Operating 97

Outside mirror – Calling up stored

settings 97

Outside mirror –Storing settings 97

Seat – Calling up stored settings 97

Seat –Storing settings 97

Menu (on-board computer)

Assistant display	233
Designs	239
Head-up display	238
Media	237
Navigation	235
Overview	229
Radio	236
Service	232
Telephone	237
Trip	233

Mercedes me

Calling up services	349
Calling up your user account	349
Deleting a connection	349
Information	348

Mercedes me connect

Accident management	347
Calling the Mercedes-Benz Customer Centre	346
Consenting to data transfer	348
Information	345
Service call with the me button	347
Service message	347
Transferred data	348

Mercedes-Benz emergency call system

Automatic emergency call	350
Information	349
Manual emergency call	351
Overview	349
Self-diagnosis	352
Starting/ending ERA-GLONASS test mode	352
Transferred data	351

Mercedes-Benz Service Centre

see Qualified specialist workshop

Message (multifunction display)

see Display message

Message memory 443**Messages** 339

Calling a message sender	340
Composing	339
Configuring the displayed text messages	339
Deleting	341
Forwarding	340
Overview	339
Read-aloud function	339

Reading	339
Replying	340
Sending	339
Using a number/URL	340
Using templates	340

Mirrors

see Outside mirrors

Mobile phone

Cancelling permission for Internet connection	354
Damage detection (parked vehicle)	167
Frequencies	430
Locking the vehicle	69
Starting the vehicle	142
Transmission output (maximum)	430
Unlocking the vehicle	69
Wireless charging	114

Mobile phone

see Android Auto

see Apple CarPlay™

see Telephone

Mobile phone voice recognition

Starting	333
Stopping	333

- Model series** 431
- MOExtended tyres** 390
- Moods**
- Calling up 267
 - Creating 267
 - Deleting 268
 - Displaying information (DIBA) 269
 - Modifying 268
 - Moving 268
 - Overview 267
- Motorway mode** 120
- MULTIBEAM LED**
see Intelligent Light System
- Multifunction display**
Setting 230
- Multifunction display (on-board computer)** 231
- Multifunction steering wheel**
Overview of buttons 228
- Multifunction steering wheel**
see Steering wheel
- Multimedia system** 281
- Activating/deactivating standby mode 168
 - Adjusting the volume 276
 - Central control elements 259
 - Configuring display settings 281
 - Main functions 263
 - Restoring the factory settings 289
 - Switching the sound on/off 275
- Multimedia system**
see MBUX multimedia system
- N**
- Navigation**
- Menu (on-board computer) 235
 - Showing/hiding the menu 292
 - Switching on 291
 - Updating the map data 324
 - Voice commands (LINGUATRONIC) 245
- Navigation**
see Destination
see Destination entry
see Route
see Route guidance
see Traffic information
- Navigation announcements**
- Activating/deactivating 310
 - Adjusting the volume 310
 - Repeating 311
 - Switching audio fadeout on/off 310
 - Switching on/off during a phone call .. 310
- Navigation messages**
On-board computer 235
- Near Field Communication (NFC)** 332
- Connecting the mobile phone to the multimedia system 332
 - Locking the vehicle (digital vehicle key sticker) 69
 - Locking the vehicle (mobile phone) 69
 - Starting the vehicle (Digital Vehicle Key sticker) 142
 - Starting the vehicle (mobile phone) 142
 - Switching mobile phones 332
 - Unlocking the vehicle (digital vehicle key sticker) 69
 - Unlocking the vehicle (mobile phone) 69
- Neutral**
Selecting 152

NFC

see Near Field Communication (NFC)

Notifications Centre

Calling up a notification 273
 Editing a notification 274
 Global search 274
 Notification types 272
 Overview 272
 Selecting actions for a notification 273
 Using the global search 274

Notifications Centre

see Notifications types

Notifications types 272

O**Occupant safety**

Pets in the vehicle 62

Occupant safety

see Airbag
 see Automatic front passenger front
 airbag deactivation system
 see PRE-SAFE® (anticipatory occu-
 pant protection)

see PRE-SAFE® PLUS (anticipatory
 occupant protection plus)
 see Restraint system
 see Seat belt

Odometer

see Total distance

Oil

see Engine oil

On-board computer

Assistant display menu 233
 Displaying the service due date 374
 Head-up Display menu 238
 Media menu 237
 Menu designs 239
 Menu overview 229
 Multifunction display 231
 Navigation menu 235
 Operating 229
 Radio menu 236
 Service menu 232
 Telephone menu 237
 Trip menu 233

On-board diagnostics interface

see Diagnostics connection

On-board electronics

Engine electronics 429
 Notes 429
 Two-way radios 429

Open-source software 29

Operating fluids

AdBlue® 436
 Brake fluid 438
 Coolant (engine) 438
 Fuel (petrol) 434
 Notes 433

Operating safety

Declaration of Conformity (electro-
 magnetic compatibility) 23
 Declaration of conformity (jack) 23
 Declaration of conformity (TIREFIT kit) .. 24
 Declaration of conformity (wireless
 vehicle components) 23
 Information 22

Operating system

On-board computer 229

Outside mirrors 131, 132

Anti-dazzle mode (automatic) 132
 Automatic mirror folding function 133

- Folding in/out 131
- Parking position 132
- Setting 131
- Using the memory function 97
- Overhead control panel**
 - Overview 12
- Owner's Manual**
 - Vehicle equipment 22
- Owner's Manual (digital)** 18
- P**
- Paint code** 431
- Paintwork (cleaning instructions)** 383
- Panic alarm** 65
 - Activating/deactivating 65
- Panoramic sliding sunroof**
 - see Sliding sunroof
- Park position**
 - Selecting 152
 - Selecting automatically 152
- Parking**
 - see Electric parking brake
- Parking (navigation service)**
 - Selecting parking options 326
 - Showing a parking option on the map 327
- Parking aid**
 - see Parking Assist PARKTRONIC
- Parking Assist**
 - Manoeuvring assistance 211
- Parking Assist PARKTRONIC** 195
 - Activating 198
 - Adjusting warning tones 198
 - Deactivating 198
 - Function 195
 - Side impact protection 197
 - System limitations 195
- Parking assistance systems**
 - see Active Parking Assist
- Parking brake**
 - see Electric parking brake
- Parking lights** 116
- Parking position**
 - Outside mirrors 132
- Storing the position of the passenger outside mirror using reverse gear 133
- Parking up** 167
- Partition net**
 - Attaching 103
- PASSENGER AIR BAG status display**
 - see Automatic front passenger front airbag deactivation system
- Pedestrian protection**
 - see Active bonnet (pedestrian protection)
- Period out of use**
 - Activating/deactivating standby mode 168
- Permissible axle load** 431
- Permitted towing methods** 400
- Petrol** 434
- Pets in the vehicle** 62
- Phone book**
 - see Contacts
- PIN protection**
 - Activating/deactivating 287
- Plastic trim (Care)** 386

POI symbols	
Custom	321
Power supply	
Switching on (Start/Stop button)	140
Power windows	
see Side windows	
PRE-SAFE® (anticipatory occupant protection)	44
Function	44
PRE-SAFE® Sound	44
Reversing measures	44
PRE-SAFE® PLUS (anticipatory occupant protection plus)	44
Function	44
Reversing measures	44
Preventative occupant protection system	
see PRE-SAFE® (anticipatory occupant protection)	
Previous destinations	
Selecting	296
Profile	
Creating a new profile	265

Maximum number of profiles	264
Notes	264
Overview	264
Selecting a profile	266
Selecting profile options	265
Showing the profile selection when entering	266
Synchronising	266

Profile

 see User profile

Programs

 see DYNAMIC SELECT

Protection of the environment

Notes	20
Take-back of end-of-life vehicles	20

Q

Qibla	325
QR code	
Rescue card	26
Qualified specialist workshop	25

R

Radar sensors	168
Radio	
Activating/deactivating radio text	371
Calling up a slide show	371
Calling up the station list	370
Deleting stations	370
Displaying information	371
Displaying radio text	371
Editing station presets	370
Entering a frequency directly	370
Frequency fix	371
Menu (on-board computer)	236
Moving stations	370
Overview	369
Searching for stations	370
Setting a station	370
Setting a voice tag	371
Setting station tracking	371
Setting the frequency band	370
Setting the traffic information	
service volume increase	371
Storing radio stations	370
Switching on	368

- Switching traffic announcements
 - on/off 371
 - Voice commands (LINGUATRONIC) 249
- Radio stations**
 - Selecting (on-board computer) 236
- Rain-closing feature**
 - Sliding sunroof 81
- Range**
 - Displaying 233
- Reading light**
 - see Interior lighting
- Real wood (Care)** 386
- Rear door (child safety lock)** 61
- Rear fog light** 117
- Rear seat**
 - see Seat
- Rear seat belt**
 - Status display 36
- Rear seat belt status display** 36
- Rear window**
 - Changing the wiper blade 130
- Rear window heater** 135
- Rear window wipers**
 - Activating/deactivating 128
- Rear-view mirror**
 - see Outside mirrors
- Recycling**
 - see Take-back of end-of-life vehicles
- Reducing agent**
 - see AdBlue®
- Refuel**
 - Refuelling the vehicle 154
- Refuelling**
 - Topping up AdBlue® 158
- Registration**
 - Vehicle 26
- Remote Online**
 - Charging the battery 144
 - Cooling or heating the vehicle interior 144
 - Starting the vehicle 144
- Replacing a bulb**
 - see Changing bulbs
- Replacing the battery (vehicle)**
 - see 12 V battery
- Replacing the vehicle battery**
 - see 12 V battery
- Rescue card** 26
- Reserve**
 - Fuel 436
- Reset function (multimedia system)** 289
- Residual heat** 138
- Restoring (factory settings)**
 - see Reset function (multimedia system)
- Restraint system** 30
 - Children 45
 - Function in an accident 31
 - Functionality 31
 - Malfunction 31
 - Protection 30
 - Reduced protection 30
 - Self-test 31
 - Warning lamp 31
- Reverse gear**
 - Selecting 152
- Reversing camera** 199
 - Care 384
 - Function 199

- Opening the camera cover (360° Camera) 205
 - Setting as a favourite (360° Camera) 205
 - Switching automatic operation on/off (360° Camera) 205
 - Reversing lights (changing bulbs)** 127
 - Rims (Care)** 384
 - Roll away protection**
see HOLD function
 - Roof lining (care)** 386
 - Roof load** 440
 - Roof rack** 107
 - Route** 299, 304
 - Accepting a detour recommendation after a prompt 317
 - Activating a commuter route 304
 - Calculating 299
 - Displaying destination information 302
 - Displaying the route list 304
 - Editing a stored route 306
 - External 312
 - Recording a route 306
 - Saving a recorded route 306
 - Selecting a type 300
 - Selecting an alternative route 304
 - Selecting notifications 302
 - Selecting options 301
 - Showing a stored route on the map 305
 - Starting a saved route 306
 - Starting the automatic service station search 305
 - Switching the automatic filling station search on/off 304
 - With intermediate destinations 303
 - Route guidance** 307
 - Cancelling 311
 - Changing direction 307
 - Destination reached 310
 - From an off-road location 311
 - Lane recommendations 309
 - Motorway information 309
 - Notes 307
 - Off-road 311
 - To an off-road destination 311
 - Route guidance with augmented reality**
 - Activating 318
 - Displaying street names and house numbers 319
 - Selecting a POI 319
 - Showing traffic lights 319
 - Switching on display of POIs 318
 - Route-based speed adaptation** 187
 - Route-based speed adjustment**
Displays in the Instrument Display 192
 - Run-flat characteristics**
MOExtended tyres 390
 - Running-in notes** 145
- S**
- Safety systems**
see Driving safety system
 - Safety vest** 388
 - Satellite map** 325
 - Seat** 101
 - 4-way lumbar support 90
 - Adjusting (electrically) 90
 - Adjusting (Seat Comfort) 89
 - adjustment (without Seat Comfort Package) 87

- Backrest (rear) locking 102
- Configuring the settings 92
- Correct driver's seat position 86
- Folding the backrest (rear) back 102
- Folding the backrest (rear) forwards 101
- Resetting the settings 92
- Selecting a massage program 92
- Setting options 14
- Using the memory function 97
- Seat**
see Head restraint
- Seat belt** 32, 36
 - Activating/deactivating seat belt
adjustment 36
 - Care 386
 - Fastening 35
 - Protection 32
 - Rear seat belt status display 36
 - Reduced protection 33
 - Releasing 36
 - Seat belt adjustment (function) 35
 - Warning lamp 36
- Seat belt adjustment**
 - Activating/deactivating 36
 - Function 35
- Seat belt tensioners**
Activation 31
- Seat belt warning**
see Seat belt
- Seat cover (Care)** 386
- Seat heater**
Activating/deactivating 93
- Seat ventilation**
Activating/deactivating 94
- Selecting a gear**
see Shifting gears
- Selecting a POI**
see Destination entry
- Selector lever**
see DIRECT SELECT lever
- Self-test**
Automatic front passenger front air-
bag deactivation system 41
- Sensors (Care)** 384
- Service**
Menu (on-board computer) 232
- Service**
see ASSYST PLUS
- Service Centre**
see Qualified specialist workshop
- Service interval display**
see ASSYST PLUS
- Service product**
Engine oil 437
- Service products**
 - Additives (fuel) 434
 - Fuel (diesel) 435
 - Windscreen washer fluid 439
- Setting a speed**
see Cruise control:
- Setting the date format** 282
- Setting the distance unit** 286
- Setting the map scale**
see Map
- Shifting gears** 152
 - Gearshift recommendation 153
 - Manual 152
- Short messages**
see Messages

- Side impact airbag** 37
- Side impact protection** 197
- Side windows** 75
 - Child safety lock in the rear 62
 - Closing 75
 - Closing using the key 77
 - Convenience closing 76
 - Convenience opening 76
 - Opening 75
 - Opening with the key 76
 - Problem 77
- Sliding sunroof** 78
 - Automatic features 81
 - Closing 78
 - Closing using the key 77
 - Opening 78
 - Opening with the key 76
 - Problem 82
 - Rain-closing feature 81
- Smartphone**
 - Locking the vehicle 69
 - Unlocking the vehicle 69
- Smartphone**
 - see Android Auto
- see Apple CarPlay™
- see Telephone
- Snow chains** 409
- Socket (12 V)** 111
 - Front centre console 111
- Socket (230 V)** 112
 - Rear passenger compartment 112
- Software update**
 - Important system updates 289
 - Information 288
 - Performing 288
- Sound**
 - PRE-SAFE® Sound 44
 - wheels and tyres 408
- Sound**
 - see Burmester® surround sound system
 - see Tone settings
- Sound settings**
 - Adjusting the balance/fader 372
 - Adjusting treble, mid-range and bass settings 372
 - Automatic volume adjustment 372
- Spare wheel**
 - see Emergency spare wheel
- Spectacles compartment** 100
- Speech dialogue system**
 - see LINGUATRONIC
- Speed Limit Assist** 213
 - Function/notes 213
- Speed limitation for winter tyres**
 - Setting 182
- Speedometer**
 - Digital 233
- Standby mode**
 - Activating/deactivating 168
 - Function 167
- Standing lights** 116
- Start/stop button**
 - Starting the vehicle 141
 - Switching off the vehicle 160
 - Switching on the power supply or ignition 140
- Start/stop function**
 - see ECO start/stop function

- Starting assistance**
 - see Jump-start connection
- Starting the engine**
 - see Vehicle
- Starting-off aid**
 - see Hill Start Assist
- Station**
 - Deleting 370
 - Entering a frequency directly 370
 - Frequency fix 371
 - Moving 370
 - Searching 370
 - Setting 370
 - Storing 370
- Station list**
 - Calling up 370
- Station presets**
 - Editing 370
- STEER CONTROL**
 - Function/notes 173
- Steering wheel** 228
 - Adjusting (manually) 94
 - Buttons 228
 - Steering wheel heater 95
- Steering wheel gearshift paddles** 152
- Steering wheel heater**
 - Activating/deactivating 95
- Stowage areas**
 - see Laden
 - see Stowage compartment
- Stowage compartment** 99
 - Armrest 99
 - Centre console 99
 - Door 99
 - Glove box 99
 - Spectacles compartment 100
- Stowage compartments**
 - see Laden
 - see Stowage compartment
- Stowage space underneath the load compartment floor** 106
- Suggestions**
 - Calling up 269
 - Configuring 269
 - Deleting 270
 - Overview 269
- Renaming 270
- Sulphur content** 434
- Sun visor**
 - Operating 134
- Surround View**
 - see 360° Camera
- Switch-off delay time**
 - Exterior 123
 - Interior 125
- Switching the surround sound on/off**
 - Burmester® surround sound system 373
- Synchronisation function**
 - Activating/deactivating (multimedia system) 137
 - Switching on/off (control panel) 137
- System settings**
 - Language 286
 - Notes on language selection 286
 - Reset function (multimedia system) 289
 - Setting the distance unit 286
 - Software update 288
- System settings**
 - see Multimedia system

- T**
- Tailgate** 73
 Closing 74
 Opening 73
 Opening dimensions 440
 Unlocking (emergency key) 74
- Tailgate**
 see Locking/unlocking
- Take-back of end-of-life vehicles** 20
 Protection of the environment 20
- Tank capacity**
 AdBlue® 437
 Fuel 436
 Reserve (fuel) 436
- Technical data**
 Axle load (trailer operation) 442
 Fastening point (trailer hitch) 441
 Information 429
 Mounting dimensions (trailer hitch) 441
 Notes (trailer hitch) 441
 Overhang dimension (trailer hitch) 441
 Tongue weight 442
 Towing weight (towing a trailer) 441
 Tyre pressure monitoring system 413
- Vehicle identification plate 431
- Telephone** 237, 328
 Activating functions during a call 333
 Calls with several participants 334
 Changing a function 331
 Connecting a mobile phone (Near Field Communication (NFC)) 332
 Connecting a mobile phone (Pass-key) 330
 Connecting a mobile phone (Secure Simple Pairing) 330
 Disconnecting a mobile phone 331
 Importing contacts 336
 Incoming call during an existing call 334
 Information 330
 Interchanging mobile phones 331
 Locking the vehicle (mobile phone) 69
 Menu (on-board computer) 237
 Mobile phone voice recognition 333
 Notes 329
 Operating modes 329
 Reception and transmission volume 332
 Ringtone volume 332
 Starting the vehicle (mobile phone) 142
- Switching mobile phones (Near Field Communication (NFC)) 332
 Telephone menu overview 328
 Telephone operation 333
 Unlocking the vehicle (mobile phone) 69
 Using Near Field Communication (NFC) 332
 Voice commands (LINGUATRONIC) 248
 Wireless charging (mobile phone) 114
- Telephone number**
 Dialling (on-board computer) 237
- Telephone operation**
 see Calls
- Telephony operating modes**
 Bluetooth® Telephony 329
 Business telephony 329
- Temperature** 135
- Text messages**
 Voice commands (LINGUATRONIC) 252
- Text messages**
 see Messages
- Through-loading feature**
 see Seat

Tie-down eyes	105	Touchpad		Towing methods	400
Time		Activating/deactivating haptic oper-		Traffic announcements	
Manual time setting	282	ating feedback	262	Activating/deactivating	371
Setting the time and date automati-		Operating	261	Traffic information	313
cally	282	Reading the handwriting recognition		Displaying the traffic map	315
Setting the time zone	282	aloud	262	Displaying traffic incidents	316
Setting the time/date format	282	Selecting a station and track	262	Live Traffic Information	314
TIREFIT kit		Setting acoustic operating feedback ...	262	Overview	313
Declaration of conformity	24	Setting the sensitivity	262	Traffic information service volume	
Using	391	Touchscreen		increase	
Tone settings	371	Entering characters	279	Setting	371
Calling up the sound menu	372	Touchscreen (multimedia system dis-		Traffic map	
Information	371	play)		see Map	
Tongue weight	442	Operating	260	Traffic Sign Assist	214
Top Tether	50	Tow-away protection		Function/notes	214
Total distance	233	Activating/deactivating	84	Setting	216
Displaying	233	Function	84	System limitations	214
Touch Control		Tow-bar system	226	Trailer hitch	
On-board computer	229	Tow-starting	404	Axle load	442
Operating	259	Towing away	401	Bicycle rack	224
Setting acoustic operating feedback ...	260	Towing eye		Fastening point	441
Setting the sensitivity	260	Installing	404	Folding the ball neck in/out	221
		Storage location	403	General notes	441

- Notes 221
- Overhang dimension 441
- Power socket 223
- Tongue weight 442
- Trailer operation**
- Active Blind Spot Assist 217
- Bicycle rack 224
- Coupling up/uncoupling a trailer 223
- Folding the ball neck in/out 221
- Notes 221
- Power socket 223
- Trailer stabilisation**
- Function/notes 173
- Trailer tow hitch**
- Care 384
- Towing weight 441
- Transferred vehicle data**
- Android Auto 345
- Apple CarPlay™ 345
- Transmission position display** 150
- Transporting**
- Vehicle 403
- Trim element (Care)** 386
- Trip**
- Menu (on-board computer) 233
- Trip computer**
- Displaying 233
- Resetting 234
- Trip distance** 233
- Displaying 233
- Resetting 234
- Trip meter**
- see Trip distance
- Turn signal indicator**
- see Turn signal light
- Turn signal light** 118
- Activating/deactivating 118
- Turn signal lights**
- Changing bulbs (rear) 127
- Two-way radios**
- Frequencies 430
- Notes on installation 429
- Transmission output (maximum) 430
- Tyre pressure**
- Checking (tyre pressure monitoring system) 412
- Notes 409
- Restarting the tyre pressure loss warning system 417
- Restarting the tyre pressure monitoring system 412
- TIREFIT kit 391
- Tyre pressure loss warning system (function) 417
- Tyre pressure monitoring system (function) 411
- Tyre pressure table 410
- Tyre pressure loss warning system**
- Function 417
- Restarting 417
- Tyre pressure monitor**
- Checking the tyre pressures 412
- Checking the tyre temperature 412
- Function 411
- Tyre pressure monitoring system**
- Restarting 412
- Technical data 413
- Tyre pressure table** 410

Tyre temperature

- Checking (tyre pressure monitoring system) 412
- Tyre pressure monitoring system (function) 411

Tyre tread 408**Tyre-change tool kit**

- Overview 421

Tyres

- Changing hub caps 422
- Checking 408
- Checking the tyre pressure (tyre pressure monitoring system) 412
- Fitting 425
- Flat tyre 390
- MOExtended tyres 390
- Noise 408
- Notes on fitting 418
- Removing 425
- Replacing 418, 422
- Restarting the tyre pressure loss warning system 417
- Restarting the tyre pressure monitoring system 412
- Selection 418

- Snow chains 409
- Storing 421
- TIREFIT kit 391
- Tyre pressure (Notes) 409
- Tyre pressure loss warning system (function) 417
- Tyre pressure monitoring system (function) 411
- Tyre pressure table 410
- Unusual handling characteristics 408





U**Units of measurement**

















- Setting 286

Unlocking setting 65**USB port** 113**User profile** 264**V**

- Vehicle** 141, 143, 144
 - Activating/deactivating standby mode 168
 - Additional door lock 68
 - Correct use 26

- Damage detection (parking) 167
- Data acquisition 27
- Diagnostics connection 25
- Equipment 22
- Implied warranty 26
- Locking (automatically) 72
- Locking (digital vehicle key sticker) 69
- Locking (emergency key) 72
- Locking (from the inside) 69
- Locking (KEYLESS-GO) 70
- Locking (mobile phone) 69
- Lowering 426
- Parking up 167
- QR code rescue card 26
- Qualified specialist workshop 25
- Raising 423
- Registration 26
- Starting (Digital Vehicle Key sticker) 142
- Starting (emergency operation mode) 143
- Starting (mobile phone) 142
- Starting (Remote Online) 144
- Starting (start/stop button) 141
- Switching off (start/stop button) 160
- Towing 226
- Unlocking (digital vehicle key sticker) 69

- Unlocking (from the inside) 69
 - Unlocking (KEYLESS-GO) 70
 - Unlocking (mobile phone) 69
 - Ventilating (convenience opening) 76
 - Voice commands (LINGUATRONIC) 253
 - Vehicle data**
 - Displaying (DYNAMIC SELECT) 150
 - Roof load 440
 - Vehicle height 440
 - Vehicle length 440
 - Vehicle width 440
 - Wheelbase 440
 - Vehicle data storage**
 - Electronic control units 27
 - Service providers 28
 - Vehicle dimensions** 440
 - Vehicle identification number**
 - see VIN
 - Vehicle identification plate**
 - EU general operating permit number ... 431
 - Maximum gross vehicle weight 431
 - Paint code 431
 - Permissible axle load 431
 - VIN 431
 - Vehicle identification plate**
 - see Model series
 - Vehicle interior**
 - Cooling or heating (Remote Online) 144
 - Vehicle key**
 - see Key
 - Vehicle maintenance**
 - see ASSYST PLUS
 - Vehicle position**
 - Transmitting 283
 - Vehicle tool kit**
 - Towing eye 403
 - Ventilating**
 - Convenience opening 76
 - Ventilation**
 - see Climate control
 - Vents**
 - see Air vents
 - VIN** 431
 - Engine compartment 431
 - Identification plate 431
 - Windscreen 431
 - Vision**
 - Demisting windows 137
 - Voice command types (LINGUATRONIC)** 242
 - Voice control system**
 - see LINGUATRONIC
- W**
- Warning lamp**
 - see Warning/indicator lamps
 - Warning system**
 - see ATA (anti-theft alarm system)
 - Warning triangle**
 - Removing 388
 - Setting up 389
 - Warning/indicator lamp**
 -  ABS warning lamp 500
 -  Brake system warning lamp
(red) 499
 -  Brake system warning lamp
(yellow) 498
 -  Coolant warning lamp 509

-  Distance warning warning lamp .. 505
-  Electrical fault warning lamp 508
-  Engine diagnosis warning lamp ... 508
-  ESP® OFF warning lamp 502
-  ESP® warning lamp flashes 501
-  ESP® warning lamp lights up 501
-  Fuel reserve warning lamp 508
-  Power steering system warning lamp 507
-  Red indicator lamp, electric parking brake applied 503
-  Restraint system warning lamp ... 504
-  Seat belt warning lamp flashes ... 505
-  Seat belt warning lamp lights up 504
-  Trailer hitch warning lamp 506
-  Tyre pressure monitoring system warning lamp flashes 512
-  Tyre pressure monitoring system warning lamp lights up 511
-  Yellow electric parking brake indicator lamp is malfunctioning 503
- Warning/indicator lamps** 496
 - Instrument display (overview) 8
 - Overview 496
 - PASSENGER AIR BAG 41
- Warranty** 26
- Washer fluid**
 - see Windscreen washer fluid
- Washing by hand (care)** 382
- Weather information** 326
- Web browser**
 - Calling up a web page 355
 - Calling up options 358
 - Calling up the settings 358
 - Deleting a bookmark 358
 - Deleting Internet history 358
 - Ending 359
 - Managing bookmarks 358
 - Overview 357
- Website**
 - Calling up 355
- Wheel change**
 - Fitting a new wheel 425
 - Lowering the vehicle 426
 - Preparation 422
 - Raising the vehicle 423
 - Removing a wheel 425
 - Removing/fitting hub caps 422
- Wheel change**
 - see Emergency spare wheel
- Wheel chock**
 - see Chock
- Wheel rotation** 421
- Wheels**
 - Care 384
 - Changing hub caps 422
 - Checking 408
 - Checking the tyre pressure (tyre pressure monitoring system) 412
 - Fitting 425
 - Flat tyre 390
 - Interchanging 421
 - MOExtended tyres 390
 - Noise 408
 - Notes on fitting 418

- Removing 425
 - Replacing 418, 422
 - Restarting the tyre pressure loss warning system 417
 - Restarting the tyre pressure monitoring system 412
 - Selection 418
 - Snow chains 409
 - Storing 421
 - TIREFIT kit 391
 - Tyre pressure (Notes) 409
 - Tyre pressure loss warning system (function) 417
 - Tyre pressure monitoring system (function) 411
 - Tyre pressure table 410
 - Unusual handling characteristics 408
- Wi-Fi**
- Overview 283
 - Setting 284
 - Setting up a hotspot 285
 - Setting up an Internet connection 353
- Windowbag** 37
- Windows**
see Side windows
- Windows (Care)** 384
- Windscreen** 128, 135
- Demisting 135
 - Replacing the wiper blades 128
- Windscreen**
see Windscreen
- Windscreen washer fluid** 439
- Notes 439
- Windscreen washer system**
Topping up 380
- Windscreen wipers**
- Activating/deactivating 127
 - Replacing the wiper blades 128
- Winter operation**
Snow chains 409
- Winter tyres**
Setting the permanent speed limitation 182
- Wiper blades**
- Care 384
 - Replacing 128
- Wireless charging**
Function/notes 113
- Mobile phone 114
- Wireless vehicle components**
Declaration of conformity 23
- Workshop**
see Qualified specialist workshop

Publication details

Internet

Further information about Mercedes-Benz vehicles and about Daimler AG can be found on the following websites:

<http://www.mercedes-benz.com>

<http://www.daimler.com>

Editorial office

You are welcome to forward any queries or suggestions you may have regarding this Owner's Manual to the technical documentation team at the following address:

Daimler AG, HPC: CAC, Customer Service,
70546 Stuttgart, Germany

©Daimler AG: Not to be reprinted, translated or otherwise reproduced, in whole or in part, without written permission from Daimler AG.

Vehicle manufacturer

Daimler AG

Mercedesstrasse 137

70327 Stuttgart

Germany

As at 12.06.17



Digital – in the vehicle

Familiarise yourself with the contents of the Owner's Manual directly via the vehicle's multimedia system (menu item "Vehicle information"). Start with the quick guide or broaden your knowledge with practical tips.



Vehicle document wallet

Here you can find comprehensive information about operating your vehicle and about services and guarantees in printed form.



Digital – on the Internet

You can find the Owner's Manual on the Mercedes-Benz homepage.



Digital – as an App

The Mercedes-Benz Guides App is available free-of-charge in familiar App stores.



1775844400Z102

Order no. P177 0027 02 Part no. 177 584 44 00 Z102
Edition NA2018-04a



Apple® iOS



Android™