

Installation and operating manual

English

synoris 550/800

For a complete manual of the operator,
please visit www.sommer-america.com



Table of contents

Important safety information	4	Programming the drive	35
About this manual	4	Checking the emergency release	36
Safe-keeping of the manual	4	Checking the power cut-off	36
Transfer of the manual	4	Testing the photoelectric barrier function	37
Target audience	4	Attaching the warning signs	38
Intended use of the drive	4		
Explanation of the warning symbols used in this manual	4	Operation	39
Signs on the product	5	Lighting	39
Explanation of the symbols used in this manual	5	Operating the drive with the remote control	39
		Operating the drive with the wall station (accessory)	40
Product and functional description	6	Emergency release from the inside	41
The drive and its mode of operation	6	Indicator lights on the control housing	41
Safety equipment	7	Resetting all values	42
		Overview of the operating and display elements as well as the connections	43
Technical data	8		
Dimensions	9	Operating and display elements, connections	43
Storing and items included in the delivery	10	Settings	44
Storage	10	Overview of special functions	44
Unpacking	10	Setting the DIP switches	45
Tools required	12		
Personal safety equipment	12	Additional functions and connections	46
		Maintenance and care	47
Tools and protective equipment	12	Regular maintenance	47
Installation dimensions and requirements	13	Maintenance schedule	47
Door types and accessories	13	Maintenance work	47
Permitted door dimensions	13	Troubleshooting guide	49
Installation requirements	13		
		Troubleshooting	49
Installation	15	Photoelectric barrier fault indicators	53
Preparation	15	Troubleshooting	54
Pre-assembly	15	Replacing light bulbs	54
Installing	18	Replacing the drive fuse	54
		Replacing hand-held transmitter battery	56
Electrical connections	24		
Connection to a power outlet or directly to the electrical supply	24	Placing out of operation and disposal	58
Power outlet connection	24	Placing the drive out of operation	58
Connection directly to the electrical supply	24	Waste disposal	58
Function	26	Battery disposal	58
Installation requirements and dimensions	26		
		Connection diagram	59
Light barrier	26	Guarantee	60
Installation (installation example)	27		
Connection	27		
Wall station (accessory)	29		
Function	29		
Unpacking	29		
Installation and connection	30		
Setting-up operation	33		
Installing light bulbs	33		
Programming the hand-held remote control	33		

Important safety information

WARNING

Please observe and comply with the following information to avoid the possible risk of severe or fatal injury to you and/or other persons.

About this manual

There is a possible risk of injury or even the risk of death if the following important safety information and the complete contents of this manual are not observed and complied with. The drive may only be installed and used when all information is observed and complied with.

You must also inform other users of this system about this manual.

Safe-keeping of the manual

Keep this manual readily available for later use when dealing with the drive.

Transfer of the manual

Please be sure to include this manual when the drive is to be installed in a different location and operated by other persons, for example, when selling the drive.

Target audience

This drive may only be operated by adults. Never permit children to operate the drive or to play in the area of the door and the drive.

All users must be trained in the competent and appropriate use of the drive.

The installation, the connection and the initial operation of the drive may only be carried out by technically knowledgeable persons.

All electrical work under voltage may only be performed by a qualified electrician.

Intended use of the drive

This specified use of this drive is for the opening and closing of doors exclusively. Any other use does not correspond with its intended use and is thus not permitted.

The drive may only be used in a technically sound state and in accordance with its intended use. It must be used safely and responsibly with adherence to the instructions and safety warnings in this installation and operating manual.

No modifications may be made to this drive.

The operating license expires if modifications are performed on this device that are not described in this manual or authorized by the manufacturer.

This device complies with Part 15 of the FCC Rules. Operation is subject to the following two conditions:

- (1) this device may not cause harmful interference, and
- (2) this device must accept every interference received, including interference that may cause undesired operation.

Malfunctions that could influence the safe operation must be corrected immediately.

Explanation of the warning symbols used in this manual

The following warning symbols are used in this manual. They warn you about possible dangers.

DANGER

Danger to life or severe personal injury

Please observe and comply with the given information to avoid the possible risk of severe or fatal injury to yourself and/or other persons.

WARNING

Possible danger to life or personal injury

Please observe and comply with the given information to avoid the possible risk of severe or fatal injury to yourself and/or other persons.

Important safety information

CAUTION

Possible damage to property

Please observe and comply with the given information to avoid the possible risk of property damage.

Signs on the product

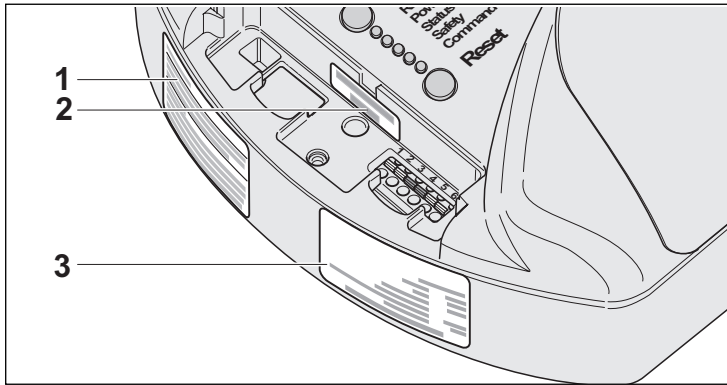

The figure shows where signs are placed on the drive. Observe and comply with the information on the signs and inform other about them.

- 1) Warning information
- 2) Specification to the safety low voltage
- 3) Identification label

Explanation of the symbols used in this manual

Tool symbols

These symbols in the manual show you when you should use specific tools. Here are a few examples:



Phillips screwdriver



Drill with 1/4" diameter wood bit



1/2" open-end wrench



Socket wrench with 3/8" socket

Other symbols



Drilling depth



Only screw in screws loosely, do not tighten yet



Now tighten the screws



It clicks into place and/or a clicking sound can be heard

Product and functional description

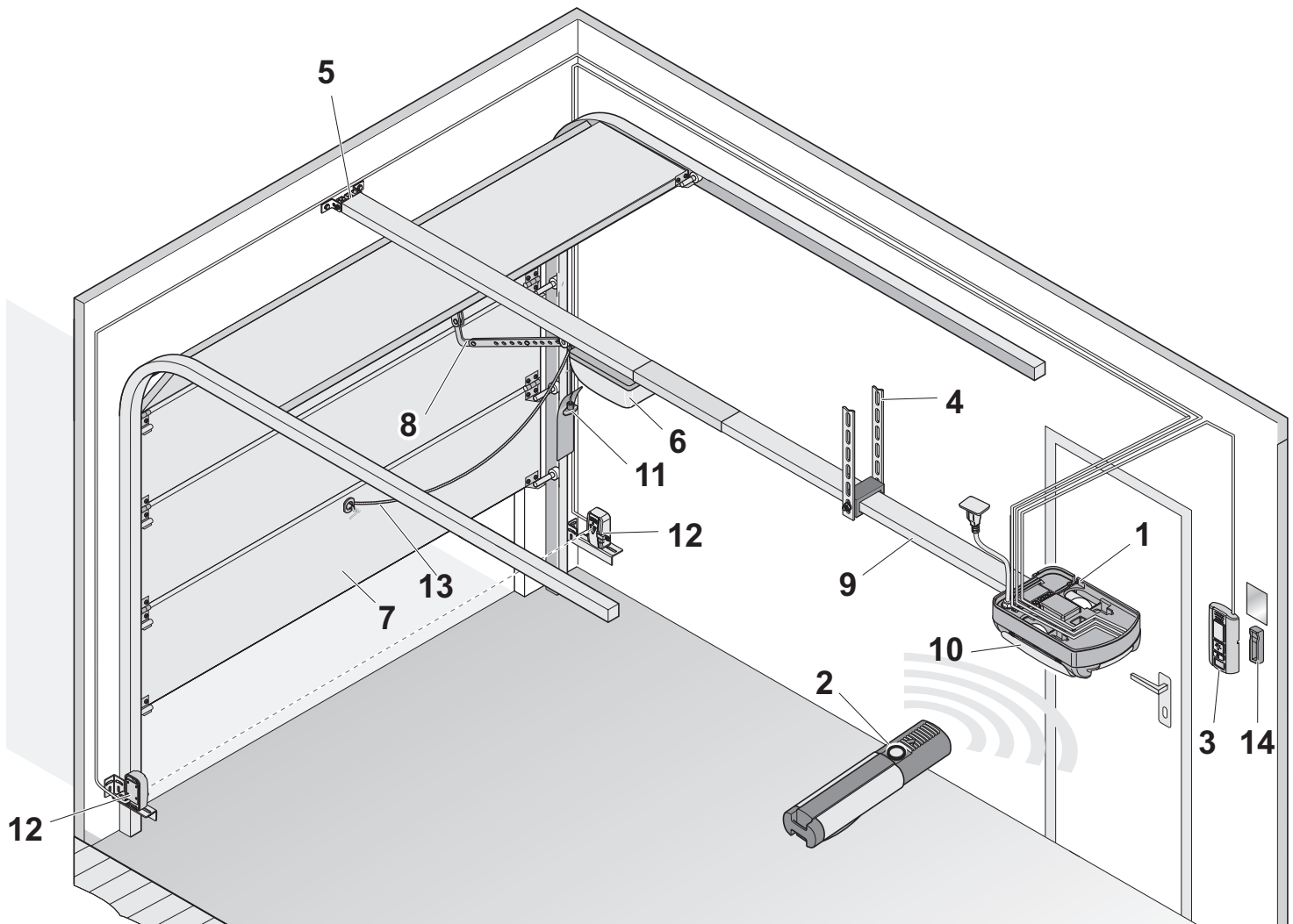

The drive and its mode of operation

Sectional doors and swinging doors can be opened and closed with this electrically powered drive (1) and its supplied accessories. (Other door types can also be operated with corresponding accessories. Please ask your specialist dealer).

The drive is controlled via a hand-held radio remote control (2), a wall station (3) (accessory) or a standard button/closer (accessory).

The drive is mounted to the ceiling structure (4) and to the header (lintel) (5) over the garage door opening. A carriage (6), which is attached to the door (7) by a door arm (8), moves along a fixed chain in the drive rail (9) and opens or closes the door.

The integrated lighting (10) is automatically activated during operation. The lighting can also be independently activated via a hand-held radio transmitter (2) or a wall station (3) (accessory) without activating the drive.

Using the wall station (3) (accessory), the drive can be locked to prevent it from being accidentally switched on during longer periods of absence (e.g. travel/vacation).

The hand-held remote control can be stored in a holder (14) (accessory) in the garage so it does not get misplaced.

Product and functional description

Safety equipment

The drive switches off if it encounters an obstacle and thus protects people from injury and vehicles or other objects from damage. If the door stops because of an obstacle during closing, it subsequently opens completely.

In the event of a power failure, the door can be opened from the inside using a mechanical emergency release (11).

A photoelectric barrier (12) safeguards the door. If the photoelectric barrier is breached, the door's closing or opening procedure is stopped. If the door stops during closing because of the photoelectric barrier, it subsequently opens completely.

Emergency release from outside (accessory)

WARNING

There is a possible risk that people could be locked into the garage.

In an emergency situation (e.g. power failure) it must be ensured that you can open the door without the drive or be able to get into the garage by another means. If the garage does not have a separate entrance or the garage door does not have a built-in door (sometimes called a "wicket door"), you must install an emergency release (13) (accessory) that can be operated from outside.

Technical data

	synoris 550	synoris 800
Running time	maximum 30 seconds	
Supply voltage	AC 120 V	
Rated frequency	50/60 Hz	
Storage locations in the radio receiver	20	
Lighting	2 x maximum 60 W, E 26 (not included in the package)	
Battery in the hand-held transmitter	Type CR 2032, 3 V	
Operational temperature range:	-4 °F to +122 °F (-20 °C to +50 °C)	
Protection system	IP 20	
Working environment based emission value	< 75 dBA – opener only	
Max. pulling and pushing force*	550 N	800 N
Rated pulling force*	165 N	240 N
Rated current consumption*	1,4 A	1,6 A
Rated power consumption*	150 W	160 W
Max. speed*	5.9 in/s (150 mm/s)	5.1 in/s (130 mm/s)
Power consumption Standby	approx. 8 W	
Weight with rails (with packaging)	approx. 7,8 kg	
Weight with rails (with packaging)	approx. 10,75 kg	
Packaging Rail package (L x W x H)	2' 5-3/4" x 11-1/4" x 5-11/16" (755 x 285 x 145 mm)	
Packaging Drive package (L x W x H)	5' 4-15/16" x 57/8" x 1-3/4" (1650 x 150 x 45 mm)	

* Values apply without lighting

Electrical connections

Connection to a power outlet or directly to the electrical supply

The drive is equipped with a 3-pole power plug and can be electrically connected by plugging it into a 3-pole power outlet. The electrical power outlet must be located within a maximum distance of 5' (1,5 m) to the controller housing.

! DANGER

There is the risk of injury or death through electrical voltage if you do not observe and comply with the following information. Therefore, observe and comply with all listed instructions before performing the electrical connection.

If a grounded 3-pole power outlet has to be installed, this may only be performed by a qualified electrician!

The drive can also be directly connected to the supply voltage. This electrical connection may only be performed by a qualified electrician!

The valid local and national regulations must be observed for the electrical connection.

Do not use an extension cable.

Do not use an adapter to bypass the grounding (3-pole to 2-pole **non**-grounded plug). Never remove or alter the ground pin on the plug.

Power outlet connection

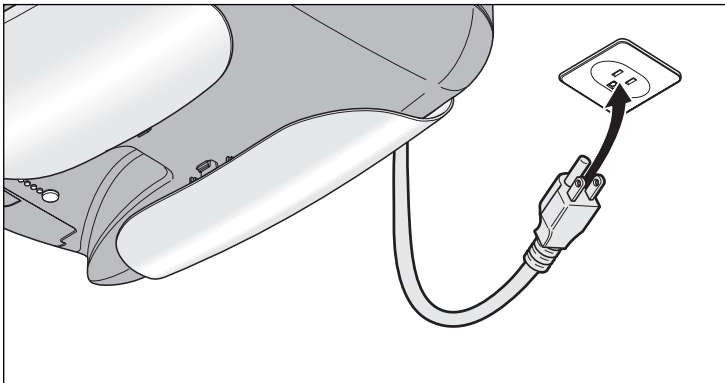

- Plug the 3-pole power plug into a grounded 3-pole power outlet.

Connection directly to the electrical supply

! DANGER

There is the risk of injury or death through electrical voltage if you do not observe and comply with the following information. Therefore, observe and comply with all listed instructions before the electrical connection.

The electrical connection directly to the electrical supply may only be performed by a qualified electrician!

The valid local and national regulations must be observed for the electrical connection.

During the installation, switch off the on-site circuit breaker or disconnect the on-site fuse for the circuit that is to supply the drive with voltage.

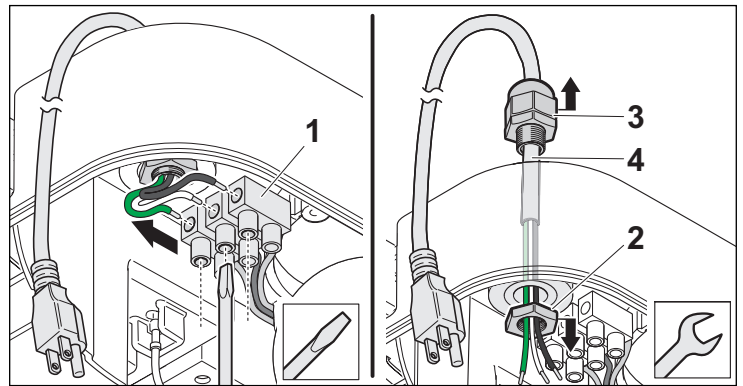

- Loosen the three cables (N = white, phase = black, ground = green) on the terminal block (1).
- Unscrew the nut (2) and remove the high-strength cable gland (3) together with the cable (4).

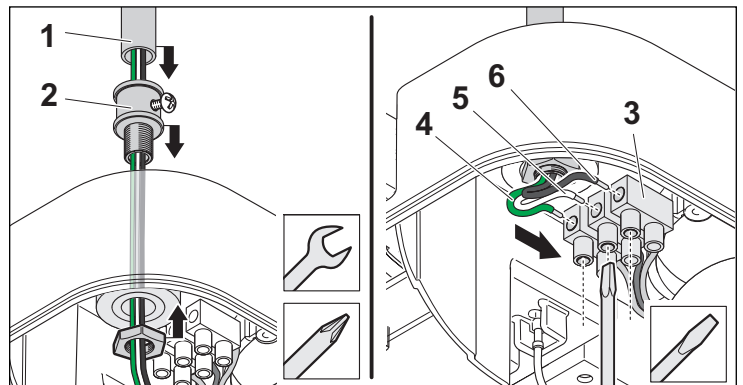

Electrical connections

- Run a cable connection from the electrical supply in an empty section of conduit (1) for example up to the input of the controller housing.
- Attach a corresponding screwed cable gland (2).
- Connect the three cables to the cable terminals of the terminal block (3):
 - N = white (4) (neutral)
 - Phase = black (5) (hot/live)
 - Earth = green (6) (ground/protection earth)

Setting-up operation

! WARNING

There is the possible risk of injury or death if a person remains within the area of the door's running path when using for the first time.

As long as the door is in motion, it should remain visible to the operator and remain clear of other people or objects. Do not allow anyone to remain within the area of motion of the door.

Installing light bulbs

! WARNING

There is the risk of injury or death through electrical voltage if you accidentally reach into the lamp socket when the drive is switched on.

Only restore the power supply when specifically told to do so in the this manual.

CAUTION

There is the risk that the drive can be damaged or catch fire if you use stronger or larger light bulbs than approved.

Use only the light bulbs specified in this manual.

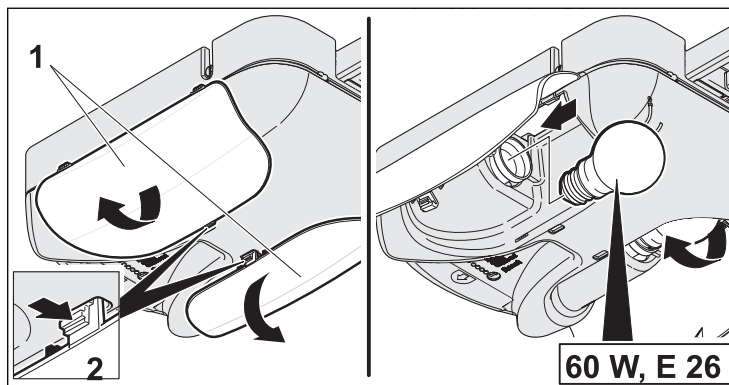

- Remove both of the lamp lenses (1). Press each of the lugs (2) in the direction of the lamp lens.
- Screw in one light bulb each (maximum 60 W, E 26) in a clockwise direction.

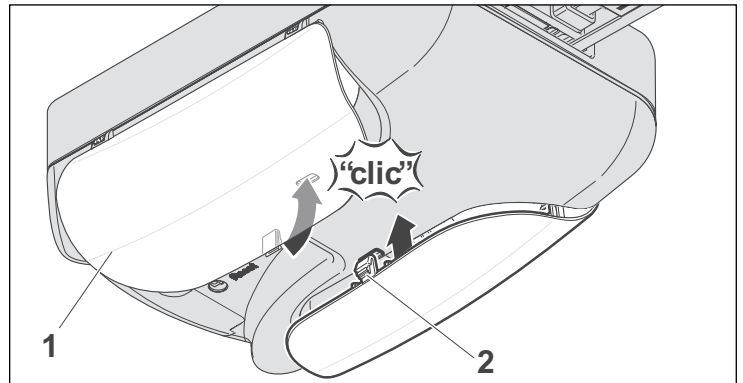

- Close both lamp lenses (1), the lugs must (2) snap into place.

Programming the hand-held remote control

In order to open, close or stop the drive using the hand-held remote control, the drive has to "learn" the code first. The radio code of the hand-held remote control is transmitted to the receiver (in the drive). You can allocate a desired remote button for this.

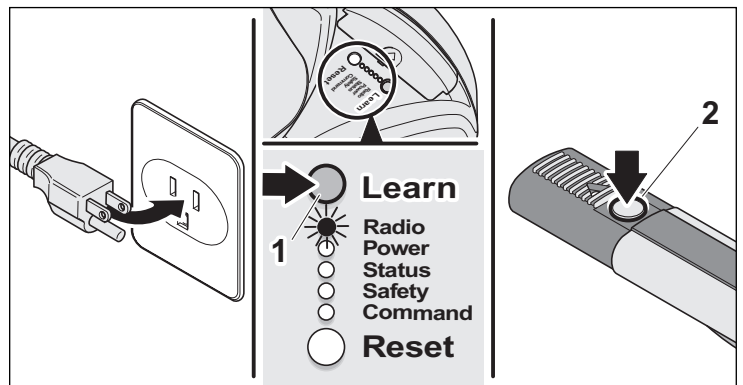

- Plug in the power plug into the power outlet or
- Switch on the the electrical supply for a direct electrical connection (switch on the circuit breaker or fuse).

When the opener is first connected to the mains supply, the opener lighting blinks. This indicates that the drive is ready to learn the code.

Learning the radio code

- Press the learn button (1) in the controller housing. The LED (Radio) lights up.
- Press a desired hand-held remote control button (2). The LED (Radio) flashes briefly .

Setting-up operation

- When the LED (Radio) lights up for a second, the hand-held remote control has been learned.
- When the LED (Radio) blinks three times, all button/storage locations are already occupied.

Programming additional hand-held remote controls: Repeat the above steps. A maximum of 20 button/storage locations for each radio receiver are available.

Lighting function

In order to be able to switch the lighting on the drive on or off separately using the hand-held remote control, a second remote control button function has to be “learned in”.

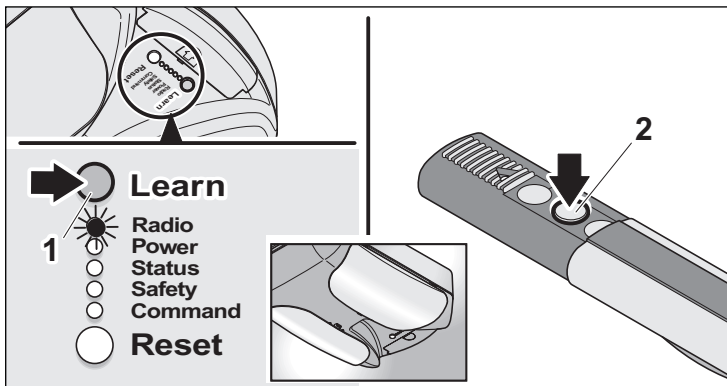

- Press the learn button (1) in the controller housing twice. The LED (Radio) briefly blinks two times.
- Press a desired hand-held remote control button (2).
 - When the LED (Radio) lights up for a second, the hand-held remote control has been learned.
 - When the LED (Radio) blinks three times, all button/storage locations are already occupied.

Other functions

Depending on the DIP switch settings, other functions such as “partial opening” or “defined operation” can be “learned in” for a second hand-held remote in the same way. See chapter “Settings”.

Aborting the learn process

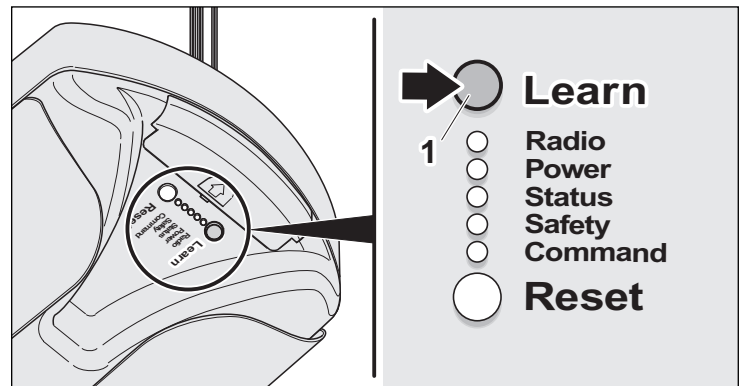

- Press the learn button (1) in the controller housing until no LED in the controller housing lights up. If no radio code is received within 10 seconds, the learning process is interrupted and has to be started again if necessary.

Deleting a learned radio code

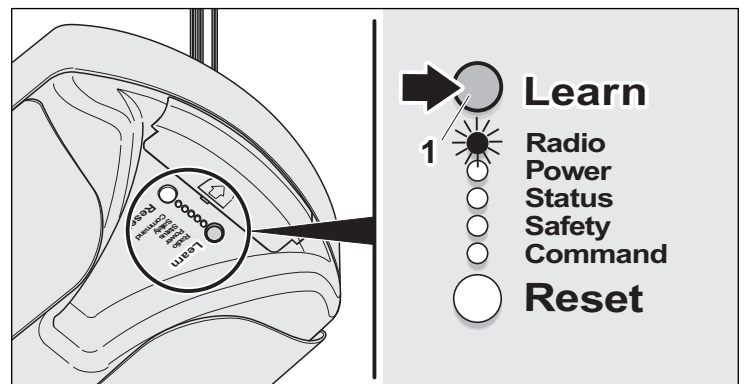

- Press the learn button (1) in the controller housing for at least five seconds until the LED (Radio) blinks slowly.
- Press the desired remote control button. The LED (Radio) lights up for a second. When the LED (Radio) turns off, the radio code of this hand-held remote control button is deleted.

Setting-up operation

Deleting all learned radio codes

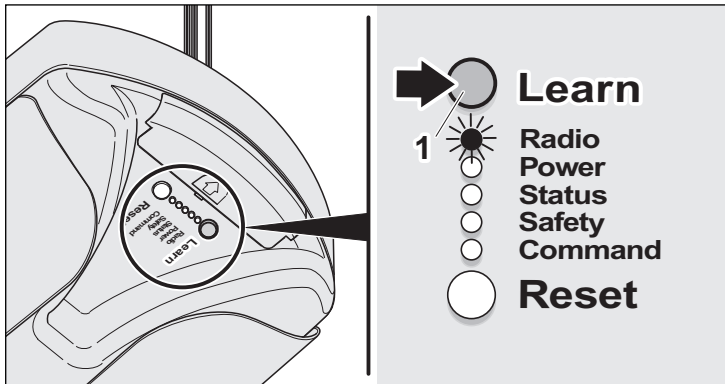

- Press the learn button (1) and hold it until
 - the LED (Radio) initially blinks for five seconds,
 - and then slowly blinks for ten seconds,
 - and subsequently blinks quickly for ten seconds.When the LED (Radio) turns off, all radio codes are deleted.
If the learn button is released prior to this, the radio codes are not deleted.

Programming the drive

The drive controller automatically detects the required force for opening and closing of the door automatically during the following drive programming procedure. The force values that are learned in are only high enough so that the drive opens and closes the door without interruption. If an obstacle (e.g. a person or a vehicle) blocks the door's movement, the drive is able to detect this since more force is required than the stored value. In this case, the drive stops the door's movement for safety reasons. If this happens during the "Door Close" movement, the door is subsequently opened completely.

For every run of the door, the controller compares the stored force values (for opening and closing of the door) with the actual value required and automatically adjusts the stored values upon reaching the end position.

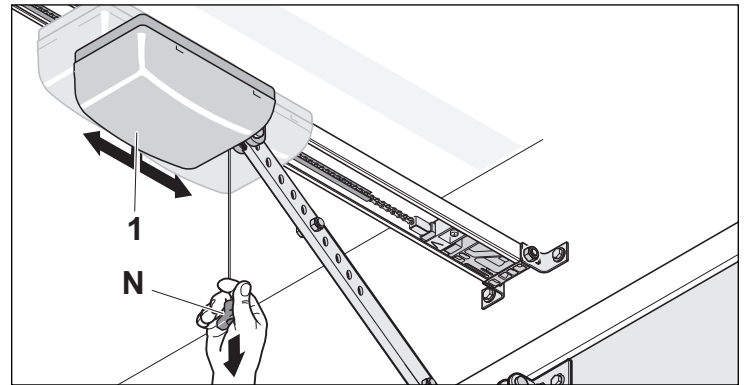

- Close the door by hand.
- Pull once on the emergency release cord grip (N) to stop the carriage (1).
- Move the carriage back and forth slightly to ensure that it is stopped in position.
- Plug the power plug into the power outlet or switch on the circuit breaker or fuse that supplies the drive with electricity.
The drive's lighting blinks when the drive is first connected to the mains supply. This indicates that the drive is ready to learn the code.

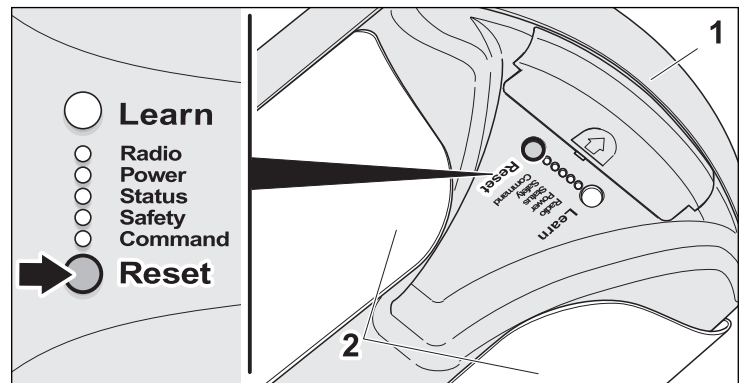

- Press the Reset button on the controller housing (1) until the lighting LED "Status" goes out. The LED "Status" blinks while being pressed.
- Release the Reset button. The lighting (2) and the LED "Status" blink.

Setting-up operation

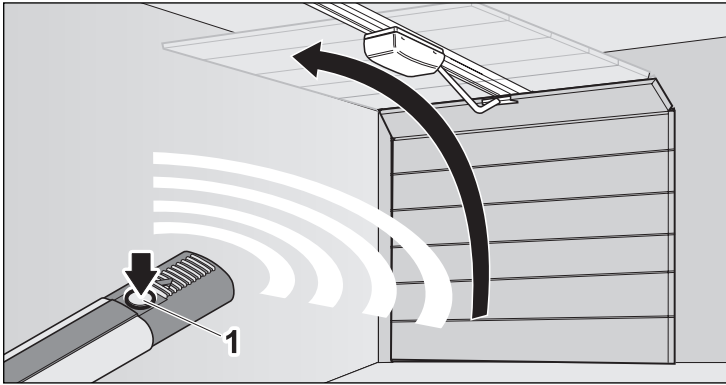

The learning process now begins, consisting of four door runs (two cycles = two times Door OPEN and two times Door CLOSE). The lighting blinks until the learning procedure has been fully completed:

1. Press the button (1) on the remote control 1x; the drive opens the door. The lighting blinks.
2. Press the button (1) on the remote control 1x; the drive closes the door. The lighting blinks.
3. Press the button (1) on the remote control 1x; the drive opens the door. The lighting blinks.
4. Press the button (1) on the remote control 1x; the drive closes the door. The lighting stays on. The learning process is completed. If the button is no longer pressed, the lighting switches off after approx. 180 seconds.

Checking the emergency release

WARNING

There is the possible risk of injury or death if the emergency release is triggered with an open door.

The emergency release should preferably be used when the door is closed. It should only be used with caution when the door is opened. Weak or broken springs can cause the door to close surprisingly quickly and thus increase the risk of serious injury or death.

- Close the door.

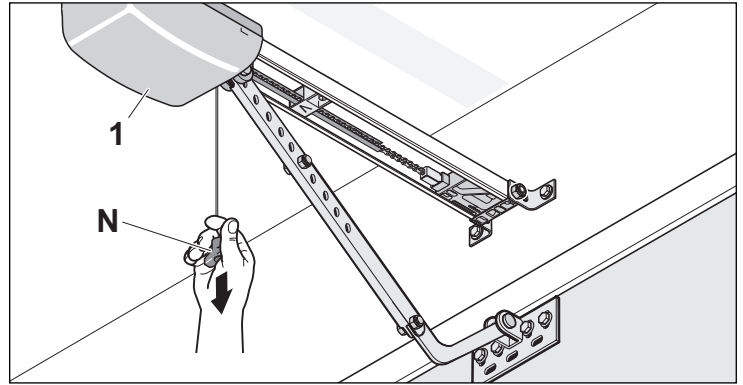

- Pull once on the emergency release cord grip (N). When functioning correctly, the carriage (1) is unlocked and the door can be moved by hand.

If the emergency release cannot be operated:

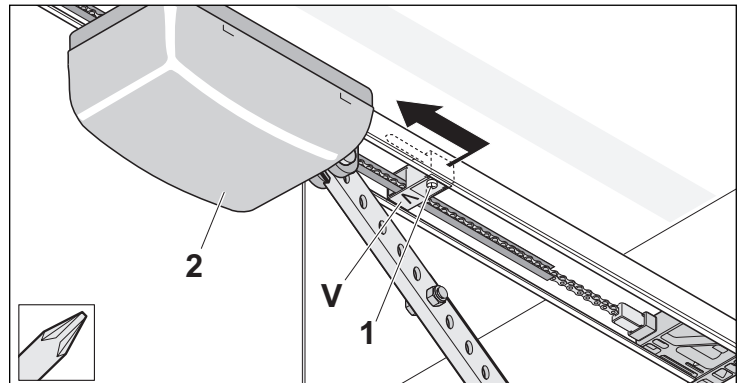

- Loosen the screw (1) on the guide idler (with the marking V) using a Phillips screwdriver and slide the guide idler a short distance, approx. 1/8" (3 mm) in the direction of the carriage (2).
- Tighten the screw (1) with a Phillips screwdriver.
- Open the close the door again using the drive.
- Check the emergency release again.

Checking the power cut-off

DANGER

There is the possible risk of injury or death if automatic power cut-off is not functioning. Persons can become clamped, jammed or pinched by a closing door that does not stop after it has encountered an obstacle.

After the drive and thus the force has been learned in, the power cut-off must be checked.

Setting-up operation

The door must change directions after contacting a 1" (25.4 mm) high object on the floor.

- Open the door with the drive.

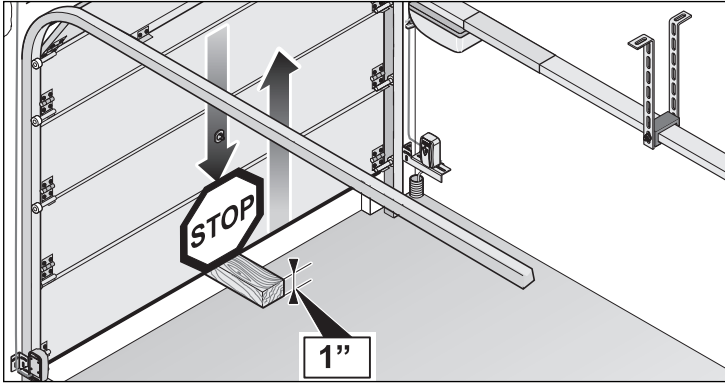

- Place an object such as a 1" (25.4 mm) high piece of plywood centered in the running path of the door.
- Close the door with the drive.
When the door contacts the object, it must stop immediately and open completely.
If the door does not open, first check the basic settings of the guide idler, see chapter "Installation". In all other cases, the drive is defective and must be repaired or replaced.
Consult your specialist dealer for advice.

Testing the photoelectric barrier function

- Close the door with the drive.

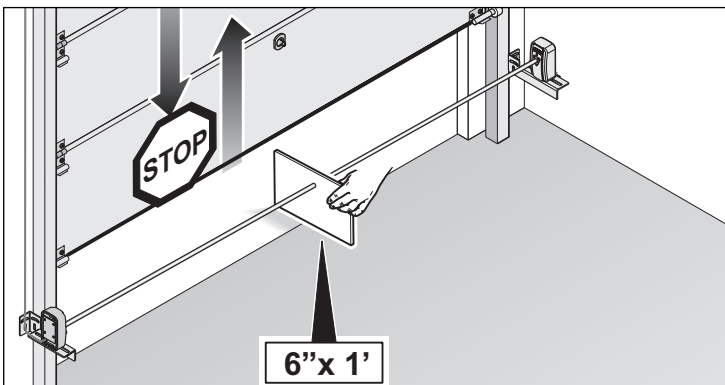

- Interrupt the photoelectric barrier during the closing procedure. Hold a 6" x 1' (152 mm x 305 mm) white object in the middle of the infrared beam between the transmitter and the receiver.
The door must stop immediately and then subsequently open completely.

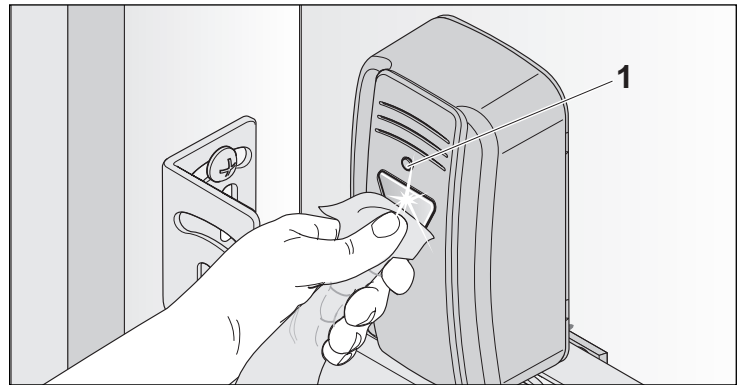

- If the door does not stop, check the following:
 - if the photoelectric barrier functions correctly: If no object or person is between the transmitter and receiver, the LED (1) on the transmitter and receiver must be **permanently** lit. If this is not the case, see chapter Troubleshooting "Fault indicators photoelectric barrier".
 - if the housing of the photoelectric barrier is dirty,
 - if transmitter and receiver are correctly aligned with each other,
 - if the cables are damaged or loose.

Setting-up operation

Attaching the warning signs

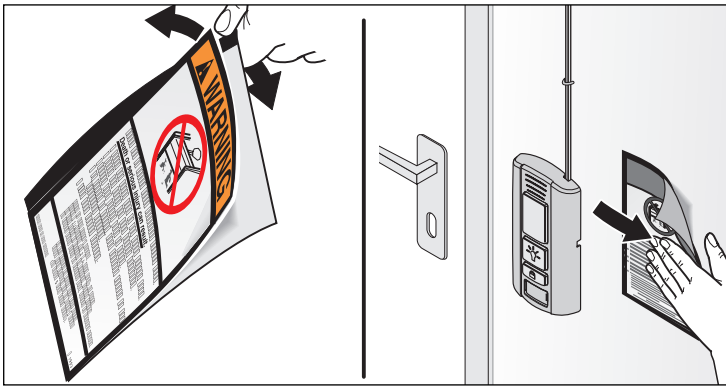

- Attach the warning sign in a clearly visible area of the garage (for example near the wall station).

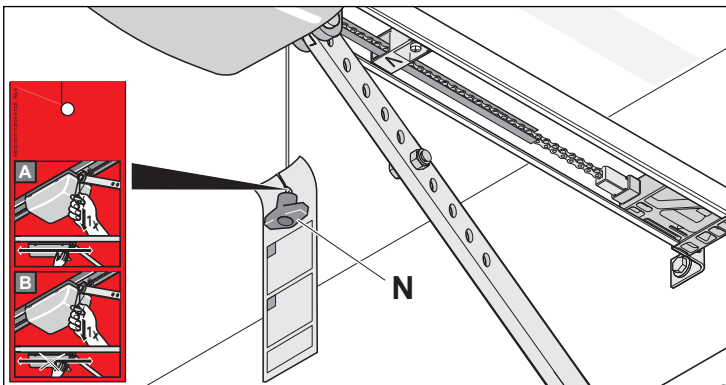

- Attach the hanging warning sign to the emergency release cord (N).

Operation

⚠ WARNING

There is the possible risk of injury or death if you do not observe and comply with the following information. Therefore, observe and comply with all listed instructions before operating.

Only operate the remote control when you have direct line of sight to the door and no persons or objects are located in the area of the door's motion.

Drive through the door opening only after the door has opened completely.

Store the remote control so that an unintended operation for example, by children or animals is prevented.

Do not use the radio remote control in areas with sensitive radio communications or systems (for example: airports, hospitals).

Lighting

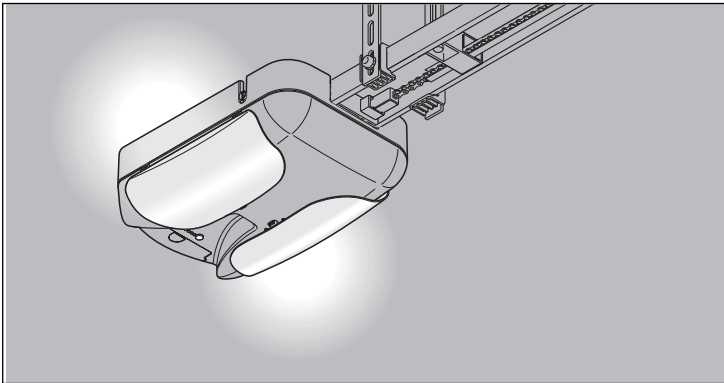

The integrated lighting switches on automatically when the drive is operated. It can also be switched on using the radio remote control or via the wall station (accessory) without the drive being in operation.

Operating the drive with the remote control

The remote control has a range up to 100 ft (30 m) depending on the surrounding area.

The remote has an integrated clip so that you can carry it as you would a pen in your shirt pocket for example.

When closed, the remote control is protected by a stainless steel case so as to prevent an unintended operation.

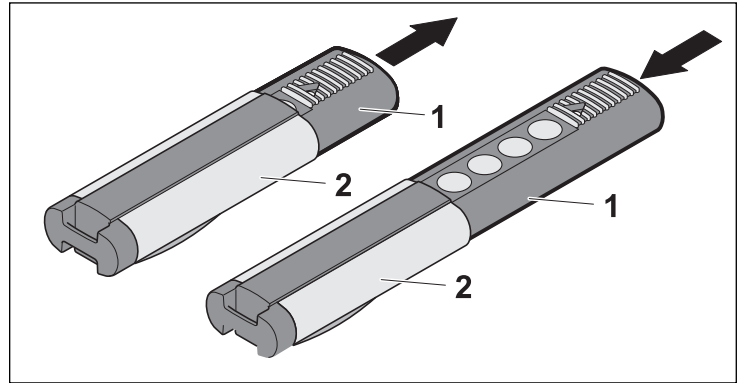

- To access the buttons, slide the remote control body (1) out of the stainless steel case (2). There are detent positions for each button (a total of 4 buttons).
- To close the remote control body (1), slide it into the stainless steel case (2) up to the stop position.

Opening, closing, and stopping the door

In order to operate the drive using the remote control, this drive function first has to “learn in” the code of a particular remote control. See “Programming the hand-held transmitter”.

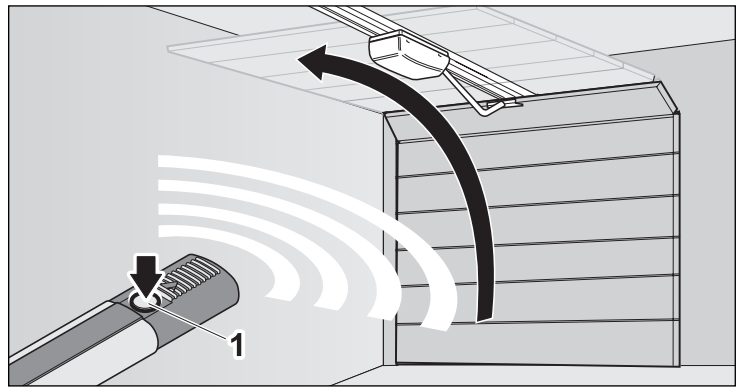

- To open and close the door, press the corresponding button on the remote control one time. Depending on the starting position, the door either opens or closes. The lighting is switched on and switches off automatically after 180 seconds.
- Press the corresponding remote control button during the open/close procedure. The door stops. The next press of the remote control button causes the door to move back to its respective starting position.

Operation

Turning the lighting on or off

In order to be able to switch the lighting on the drive on or off separately using the hand-held remote control, a second remote control button has to be “learned in” and assigned to this function. See “Programming the hand-held transmitter”.

- Press the corresponding remote control button one time to switch on.
The lighting is switched on and switches off automatically after 180 seconds.
- Press the corresponding remote control button one time to switch off.
The lighting switches off. If the lighting was automatically switched on during the drive movement, it can only be switched off after the drive movement has completed.

Operating the drive with the wall station (accessory)

Opening, closing, and stopping the door

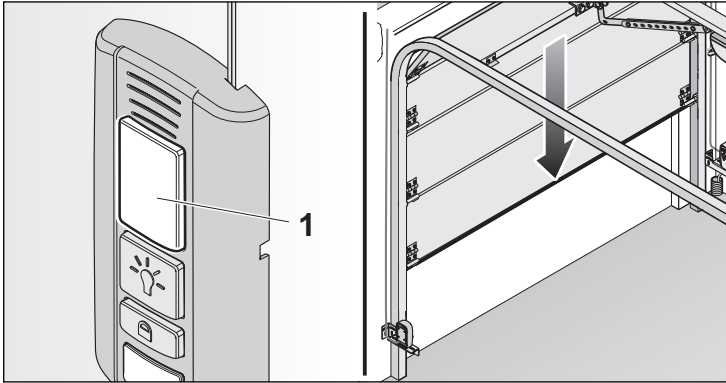

- To open and close, press the button (1) one time.
The door opens or closes depending on the starting position. The lighting is switched on and switches off automatically after 180 seconds.

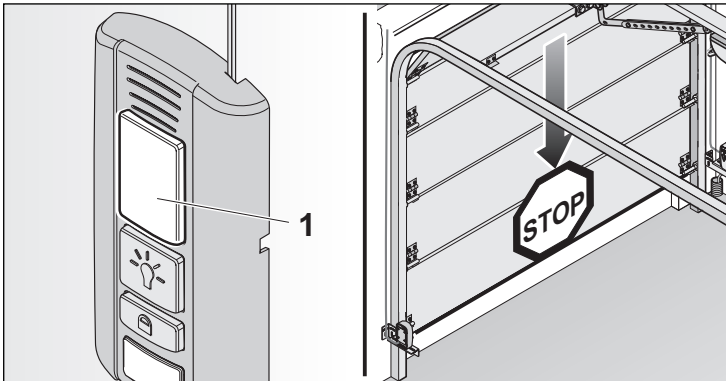

- To stop, press the button (1) during the open/close procedure one time.
The door stops. The next press of the button (1) causes the door to move back to its respective position.

Turning the lighting on or off

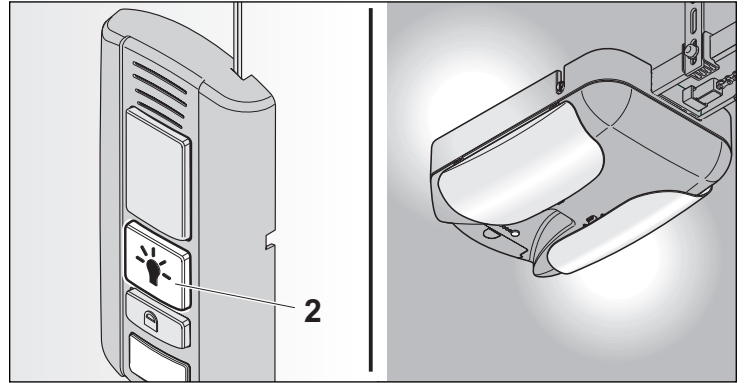

- Press the corresponding button (2) one time to switch on.
The lighting is switched on and switches off automatically after 180 seconds.
- To switch off, press the button (2) one time.
The lighting switches off. If the lighting was automatically switched on during the drive movement, it can only be switched off after the drive movement has completed.

Lock or unlock the drive

The drive can be locked to prevent it from being accidentally switched on (by a remote control as well) during longer periods of absence (e.g. travel/vacation).

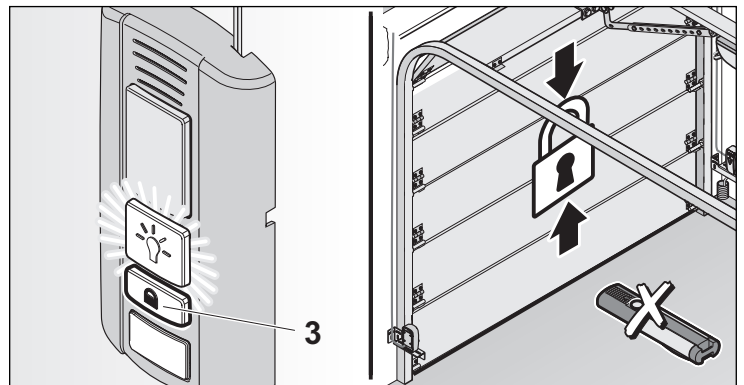

- To lock, press and hold the button (3) with a closed door (at least 5 seconds), until the illumination of the light button lights up red.
All drive functions are locked.
If the door is opened during the locking, it can still be closed using the hand-held remote control. Then all drive functions are locked.

Operation

- To unlock, press and hold the button (3) (at least 5 seconds), until the illumination of the light button lights up green (it blinks red until then).
All functions of the drive are unlocked and active.

Emergency release from the inside

In the event of a power failure, the door can be opened from the inside using a mechanical emergency release.

WARNING

There is the possible risk of injury or death if the emergency release is triggered with an open door.

The emergency release should preferably be used when the door is closed. It should only be used with caution when the door is opened. Weak or broken springs can cause the door to close surprisingly quickly and thus increase the risk of serious injury or death.

Activating the emergency release

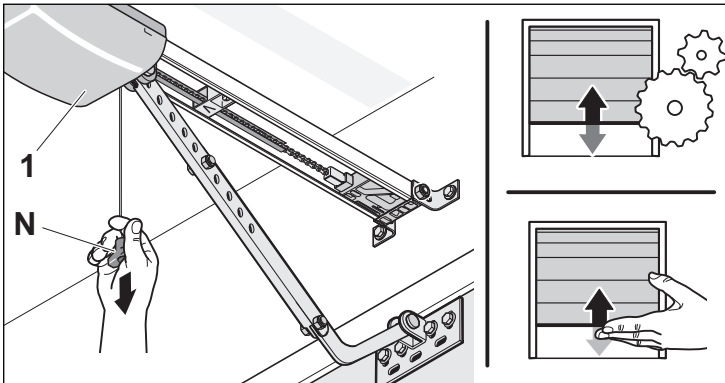

- Pull once on the grip of the emergency release cord (N). The carriage (1) is unlocked and the door can be moved by hand.

Resetting the emergency release

- Pull once on the grip of the emergency release cord (N). The carriage (1) is engaged and the door can now only be moved by the drive.

Indicator lights on the control housing

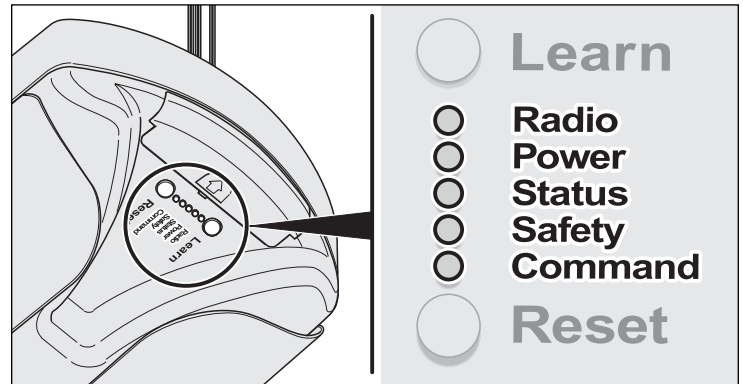

Description	Signal	Function
Radio	Red (LED)	Lights up or blinks during “learning” of a remote control respective of the programming state. See “Programming the hand-held transmitter”. Lights up, as long as a hand-held remote control button for starting the drive is pressed.
Power	Red (LED)	Light up when the drive is supplied with voltage.
Status	Red (LED)	Always blinks while the drive opens/closes the door. If the drive is not yet learned in, the LED also blinks when the drive is in the stopped state. In the learned in state, the LED is off when the drive is in the stopped state.
Safety	Red (LED)	Lights up if the photoelectric barrier is interrupted. As long as a correct signal is coming from the photoelectric barrier, the LED is off.
Command	Red (LED)	Lights up if the drive is started via a hand-held remote control or a wall station (accessory) for example.

Operation

Resetting all values

All learned values can be reset (e.g. learned in force values for closing and opening the door).

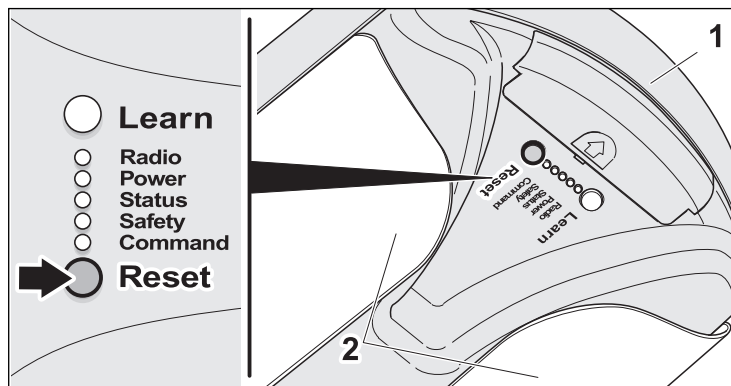

- Press the Reset button on the controller housing (1) until the lighting LED "Status" goes out. While pressing, the LED "Status" blinks.
- Release the Reset button. The lighting (2) and the LED "Status" blink.

The drive must subsequently be relearned, see chapter Using for the first time "Programming the drive".

Operating and display elements, connections

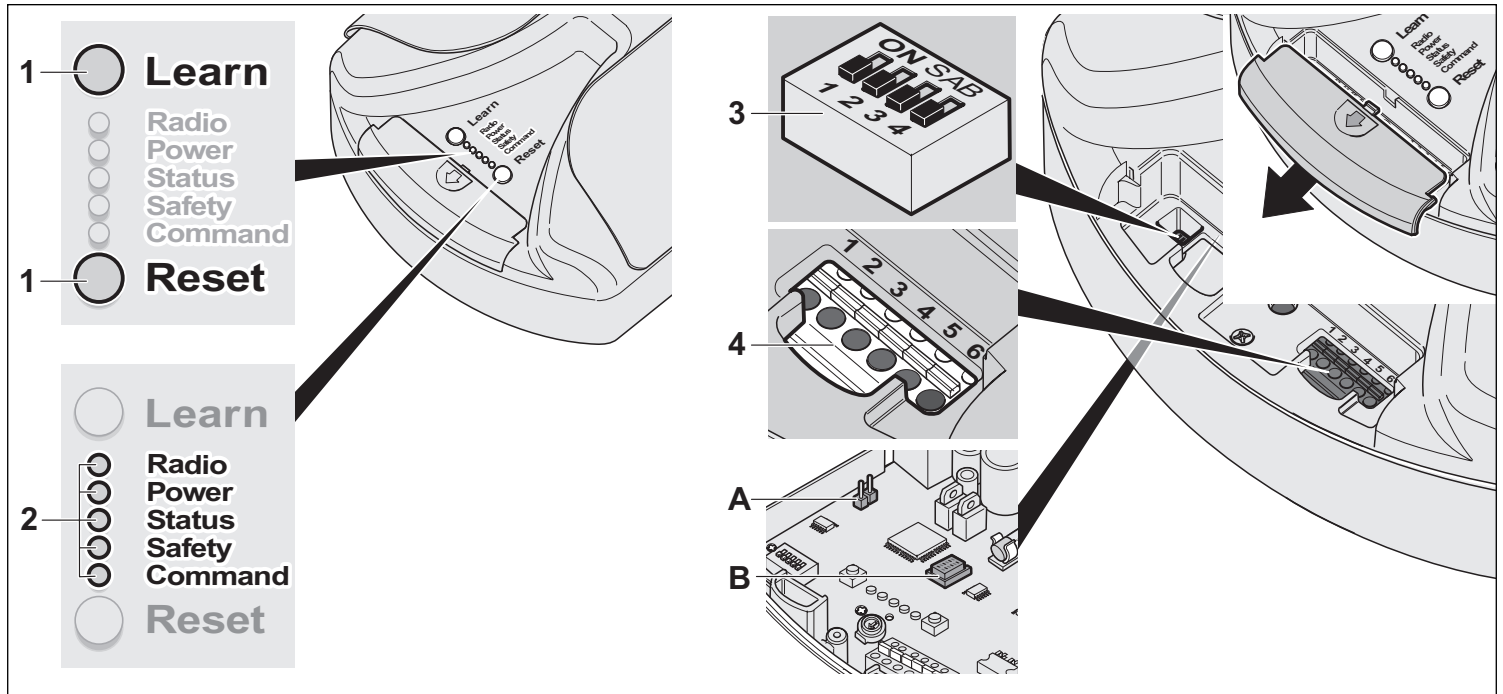

Overview of the operating and display elements as well as the connections

This overview serves to give you a quick orientation. It shows the most important operating and display elements as well as the connections on the drive. A cross-reference shows you where to find a detailed description in each case.

Buttons (1) *

- Learn (e. g. learn in the hand-held remote control)
- Reset (e. g. reset value)

* Details see chapter “Using for the first time”

Indicator lights on the control housing (2)*

- Radio (learn in the hand-held remote control)
- Power (voltage supply)
- Status (open/close)
- Safety (photoelectric barrier interrupted)
- Command (signal reception e.g. from hand-held remote control)

* Details see chapter “Operation”

DIP switches (3) *

DIP switches for set-up of special functions:

- (1) Soft running (soft opening and closing)
- (2) Backjump (relieve door mechanics)
- (3) Defined opening and closing
- (4) Partial opening

* Details see chapter “Settings”

Additional functions and connections (4) *

Terminal for connection of accessories:

- (1+2) DC 24 Volt (connect accessories with 24 V)
- (3+4) Command (connect control device)
- (5+6) Photocell (connect photoelectric barrier)

(A) External antenna (connect additional antenna)

(B) TorMinal (connect programming device)

* Details see chapter “Additional functions and connections”

Settings

Overview of special functions

You can set these functions using the DIP switches, see following section.

Function	DIP switches	Function for “OFF” setting (factorysetting)	Function for “ON” setting
<p>Soft running for “soft” opening and closing of the door.</p>	1	The drive always starts with the soft running speed from the “Door OPEN” and “Door CLOSE” end positions. It accelerates to the maximum speed and before reaching the end position, it reduces the speed again to the soft running speed. A soft and quiet opening and closing is thus possible.	The drive moves with constant speed between the end points/guide idlers.
<p>Backjump for relieving the door and drive mechanics when closing the door.</p>	2	When closing the door, the drive moves to the defined end position over the guide idler and stops. It subsequently moves slightly in the “Door OPEN” direction to relieve the drive mechanics of stress.	The drive moves to the defined end position over the guide idler and stops
<p>Defined opening and closing.</p>	3	Switched off.	<p>To be able to use this function, two remote control buttons for opening/closing have to have been programmed. See chapter “Programming the hand-held transmitter”.</p> <p>Button assignment example: Button 1: the door opens. Button 2: the door closes.</p> <p>The lighting can now no longer be switched on/off via button 2 of the hand-held remote control.</p>
<p>Partial opening for partially opening the door (for example for air circulation in the garage or with sectional doors for example for an entry for people or for accessing a bicycle).</p> <p>Caution: If the DIP switch 4 is set to “ON” then DIP switch 3 is automatically deactivated.</p>	4	To partial opening, the drive opens/closes the door completely.	<p>To be able to use this function, two remote control buttons for opening/closing have to have been programmed. See chapter “Programming the hand-held transmitter”.</p> <p>Button assignment example: Button 1 for normal operation: the door opens/closes completely (independent of the starting position). Button 2 for partial opening operation: the door opens partially (must be set. See “Setting position for partial opening”). Subsequently open the door completely with button 1 to again close it with button 1 or 2.</p> <p>The lighting can now no longer be switched on/off via button 2 of the hand-held remote control.</p>

Settings

Setting the DIP switches

You can set up special functions via the DIP switches. By default, all DIP switches are set to "OFF". The power supply must be switched off during the setup. The settings only become active after the power supply has been switched on after making the changes.

- Pull the power plug out of the power outlet.
Or for a direct connection to the power mains:
- Disconnect the drive from the power (switch off the circuit breaker to the drive or disconnect the fuse) and check to be sure no voltage is present.

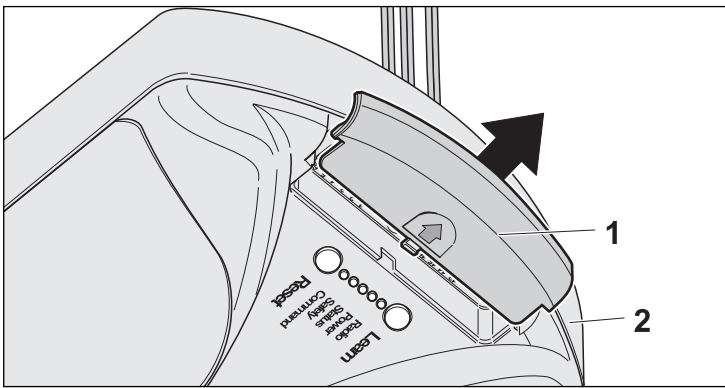

- To set the DIP switches, slide the covering (1) in the controller housing (2) outwards and remove.

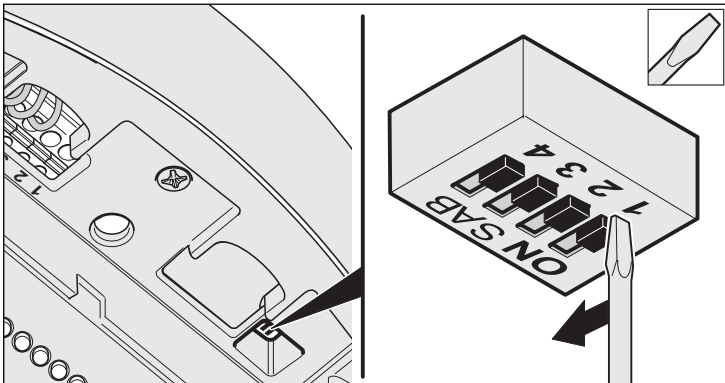

- The DIP switches can be set using a small screwdriver.
- After setting the DIP switches, place the covering in the controller housing again and slide it inwards.
- Plug the power plug back into the power outlet
or
- switch on the the electrical supply for a direct electrical connection (switch on the circuit breaker or fuse).

Setting the position for partial opening

You can set in which position the door stops using the "partial open" function.

- Close the door with the drive.
- Set the DIP switch 4 to "ON".
- Press one of the desired remote control buttons for this function (for example button 2). The door opens. The remote control button has to have previously "learned" this function. See chapter Using for the first time, "Programming the hand-held transmitter".

When the desired position has been reached:

- Press the button 2 again. The door stops.
- Press the button 2 once more. The door closes.
The position for the partial opening is saved and remains stored as long as the DIP switch 4 is set to the "ON" position.

Deleting the setting:

- Set the DIP switch 4 to "OFF". The setting is permanently deleted and must be set again if needed (using DIP switch 4 to "ON").

Additional functions and connections

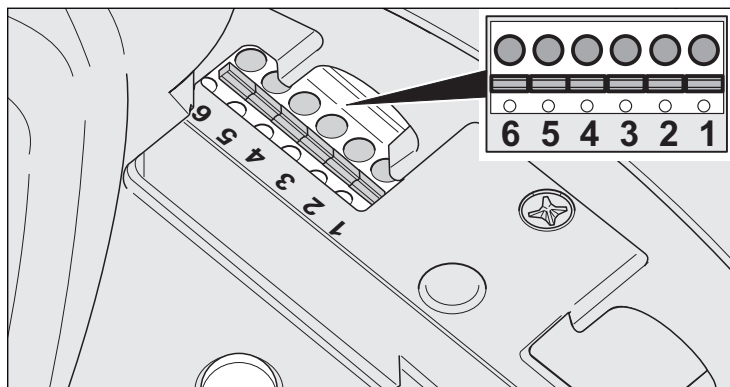

Description	Connection to terminal	Function / Application example
DC 24 Volt	1 + 2	Corresponding accessories with 24 volt voltage can be connected.
Command	3 + 4	A control device can be connected, for example a wall station (accessory).
Photocell	5 + 6	Die mitgelieferte Lichtschranke wird hier angeschlossen.

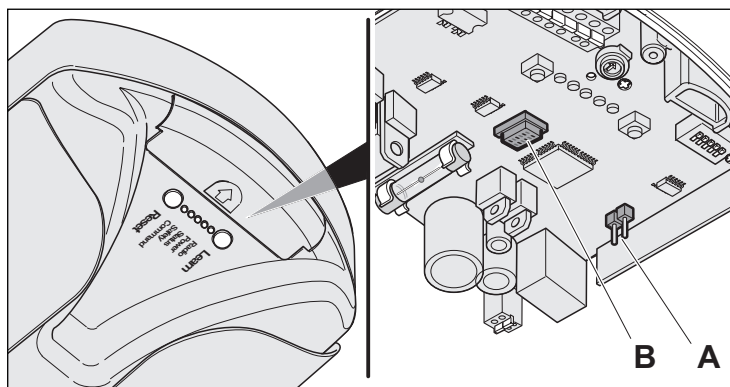

Description	Connection	Function / Application example
External antenna	A	External antenna (accessory) connection for improved reception or increasing the range.
TorMinal	B	Device connection for reading out and changing the control parameters (accessory for specialist users).

Maintenance and care

Regular maintenance

Maintain and care for the drive regularly as described in the following. This ensures safe operation and increases the operating life of your drive.

WARNING

There is the possible risk of injury or death through electrical voltage from improper cleaning with water.

Never spray the opener or the controller housing with water from a hose or with a high-pressure cleaner. This can lead to a short-circuit.

There is the possible risk of injury or death through an accidentally switched on drive.

You must disconnect the drive from the power supply when performing any work on the door. Pull out the power plug from the power outlet or switch off the the on-site circuit breaker or disconnect the on-site fuse for the circuit that supplies the drive with voltage. Subsequently test to be sure the drive is disconnected from the power by switching it on (the drive must not move).

Never touch or grab the moving door or other moving parts. You could be crushed or jammed by the mechanics or the closing edges of the door.

CAUTION

There is a possible risk of damaging the drive surface through the use of improper cleaning agents.

Never clean the drive with aggressive cleaning agents such as acids or bases. Only use the specified cleaning agents and methods.

Maintenance schedule

When	What	How
Once a month	Test the emergency release function	See chapter Using for the first time, "Checking the emergency release"
	Check the power cut-off	See chapter Maintenance, "Maintenance work"
	Checking the photoelectric barrier function.	See chapter Maintenance, "Maintenance work"
Once a year	Check the door and all moving parts	According to the manufacturer's instructions.
	Check the mounting bolts of the drive	Check for tightness and tighten if necessary
As needed	Clean the chain and C-rail.	See chapter Maintenance, "Maintenance work"
	Clean the controller housing and the carriage	With a dry lint-free cloth

Maintenance work

Cleaning the chain and C-rail

WARNING

There is the possible risk of injury or death through an accidentally switched on drive.

You must disconnect the drive from the power supply when cleaning the drive. Pull out the power plug from the power outlet or switch off the the on-site circuit breaker or disconnect the on-site fuse for the circuit that supplies the drive with voltage. Subsequently test to be sure the drive is disconnected from the power by switching it on (the drive must not move).

- Pull the power plug out of the power outlet.
Or for a direct connection to the power mains:

Maintenance and care

- Disconnect the opener from the power (switch off the circuit breaker to the opener or disconnect the fuse on the circuit supplying the opener with voltage) and check to be sure no voltage is present.
- Remove coarse dirt from the C-rail.
- The chain must be cleaned with a lint-free cloth and then lubricated with an electrically conductive lubricant (WD-40).
Never oil or grease the chain. This can lead to a malfunction caused by insufficient electrical contact.
- Plug in the power plug into the power outlet or
- Switch on the the electrical supply for a direct electrical connection (switch on the circuit breaker or fuse).

Checking the power cut-off

DANGER

There is the possible risk of injury or death if the automatic power cut-off is not functioning. Persons can become clamped, jammed or pinched by a closing door that does not stop after it has encountered an obstacle.

The door must change directions after contacting a 1" (25.4 mm) high object on the floor.

Check the power cut-off monthly.

- Open the door with the drive.

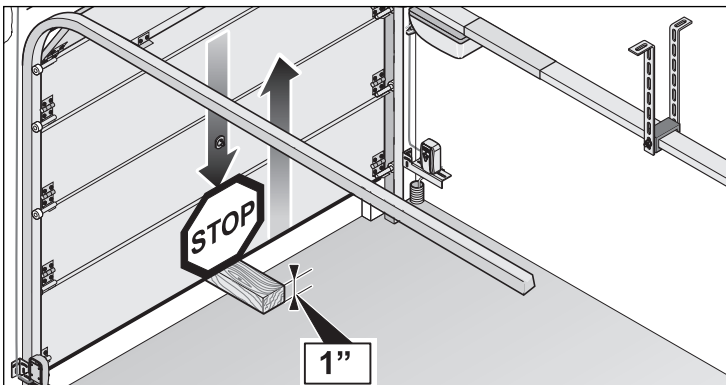

- Place an object such as a 1" (25,4 mm) high piece of plywood centered in the running path of the door.
- Close the door with the drive.
When the door contacts the object it must stop immediately and open completely.

If the door does not open, the drive is defective and must be repaired or exchanged. Consult your specialist dealer for advice.

Testing the photoelectric barrier function

- Close the door with the drive.

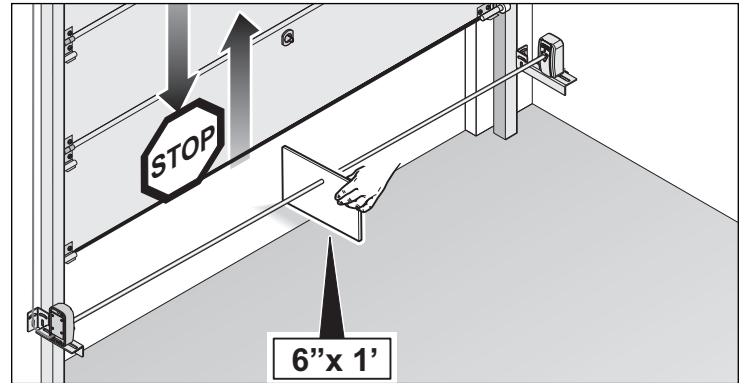

- Interrupt the photoelectric barrier during the closing procedure. Hold a 6" x 1 (152mm x 305mm) white object in the middle of the infrared beam between the transmitter and the receiver.
The door must stop immediately and then subsequently open completely.

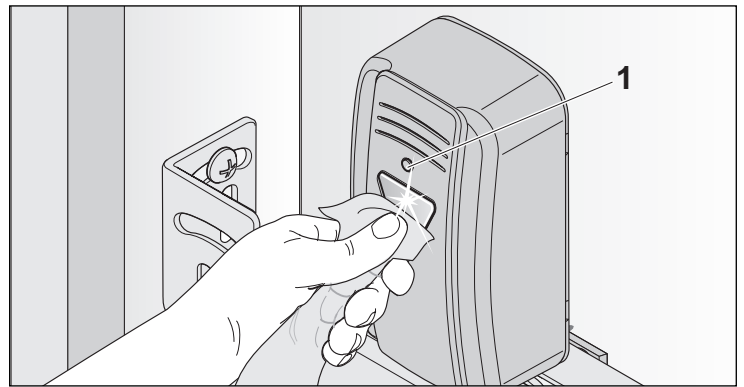

- If the door does not stop, check the following:
 - if the housing of the photoelectric barrier is dirty,
 - if transmitter and receiver are correctly aligned with each other,
 - if the photoelectric barrier functions correctly: If no object or person is between the transmitter and receiver, the LED (1) on the transmitter and receiver must be permanently lit. If this is not the case, see chapter Troubleshooting "Fault indicators photoelectric barrier".
 - if the cables are damaged or loose.

Troubleshooting

Troubleshooting guide

The following troubleshooting guide will help you find possible faults and their causes as well as information about how you can remedy these yourself. In specific cases, other chapters and sections are referenced in which the procedures are more closely described. You are instructed when you must have the fault remedied by a specialist.

WARNING

There is the possible risk of injury or death if certain work for troubleshooting is carried out without having the corresponding expertise.

For specific troubleshooting work, technical knowledge is absolutely necessary. Have the fault repaired by a trained specialist exclusively when you are instructed to do so in the troubleshooting overview.

Fault/Behavior	Possible causes	Test/Check	Repair
Drive does not open or close the door after pressing the “Open/Close” button at the wall station (accessory).	<ol style="list-style-type: none">1. No voltage present	<ol style="list-style-type: none">1. “Safety” LED on the controller housing is permanently lit.	<ol style="list-style-type: none">1. Check the power outlet with a different device, for example by plugging in a drill or a lamp.
	<ol style="list-style-type: none">2. Electrical supply voltage outside of the tolerance range.	<ol style="list-style-type: none">2. Have the mains voltage checked by a specialist.	<ol style="list-style-type: none">2. Have the cause of the anomaly remedied by a specialist.
	<ol style="list-style-type: none">3. Photoelectric barrier not mounted and connected.	<ol style="list-style-type: none">3. “Safety” LED on the controller housing is lit.	<ol style="list-style-type: none">3. Mount the photoelectric barrier and connect.
	<ol style="list-style-type: none">4. Photoelectric barrier interrupted/triggered.	<ol style="list-style-type: none">4. “Safety” LED on the controller housing is lit. Are any objects in the path of the photoelectric barrier?	<ol style="list-style-type: none">4. Remove object.
	<ol style="list-style-type: none">5. Drive/controller defective.	<ol style="list-style-type: none">5. Drive/controller does not start with hand-held transmitter or wall station (accessory).	<ol style="list-style-type: none">5. Have the drive repaired by a specialist or have the drive exchanged.
	<ol style="list-style-type: none">6. Drive locked.	<ol style="list-style-type: none">6. “Command” LED “Command” on the controller housing lit. LED on the wall station lit up red	<ol style="list-style-type: none">6. Unlock the drive by pressing the “Lock/Unlock” button (approx. 5 seconds) on the wall station (accessory) again.
	<ol style="list-style-type: none">7. Drive has been unlocked via emergency release mechanism.	<ol style="list-style-type: none">7. Carriage cannot be moved by hand.	<ol style="list-style-type: none">7. Interlock the drive by pulling on the emergency release cord again.
	<ol style="list-style-type: none">8. Maximum cable length of 22 yd (20 m) exceeded.	<ol style="list-style-type: none">8. LED on the wall station (accessory) is not illuminated. Try connecting the wall station (accessory) to the drive with a short cable as a test.	<ol style="list-style-type: none">8. Install the wall station (accessory) to the drive with a shorter cable at a different location.

Troubleshooting

Fault/Behavior	Possible causes	Test/Check	Remedy
	9. Wall station (accessory) not mounted and connected.	9. LED on the wall station does not light up. When connected correctly, this lights up green.	9. Mount the wall station (accessory) and connect.
	10. Broken wire/ short circuit.	10. LED on the wall station does not light up	10. Repair or replace the cable.
	11. Wall station (accessory) incorrectly connected to the drive.	11. Drive functions with hand-held transmitter and points 6,8,9,10,11 are OK.	11. Wall station (accessory) must be connected to terminal 3+4.
	12. Wall station (accessory) defective.	12. –	12. Replace the wall station (accessory).
	13. Short circuit, for example through contact with the chain and C-rail from damaged chain guide.	13. Check the fuse in the drive.	13. Replace fuse in the drive, see “Troubleshooting”.
Drive does not open or close the door after pressing a button on the remote control.	1. See points 1, 2, 3, 4, 5, 6, 7 above.	1. See points 1, 2, 3, 4, 5, 6, 7 above.	1. See points 1, 2, 3, 4, 5, 6, 7 above.
	2. Hand-held transmitter not programmed.	2. “Command” LED does not light up when the hand-held remote control is operated.	2. Program the hand-held transmitter.
	3. Hand-held transmitter defective.	3. LED on the hand-held remote control does not light up.	3. Replace the hand-held remote control.
	4. Battery empty.	4. –	4. Replace the battery, see “Troubleshooting”.
	5. Short circuit, for example through contact with the chain and C-rail from damaged chain guide.	5. Check the fuse in the drive.	5. Replace fuse in the drive, see “Troubleshooting”.
Lighting on the drive does not function.	1. See points 1, 2 above.	1. See points 1, 2 above.	1. See points 1, 2 above.
	2. No light bulb installed.	2. Open the cover and check whether light bulbs are installed.	2. Replace light bulbs, see chapter “Using for the first time”.
	3. Defective light bulb.	3. –	3. Replace the light bulbs, see “Troubleshooting”.
Drive stops while the door is closing and opens the door again completely.	1. Door contacted an obstacle.	1. Check the area of the door’s motion for possible object present.	1. Remove object.
	2. Photoelectric barrier was interrupted.	2. Check LED on the photoelectric barrier and “Safety” LED on the controller housing.	2. Remedy the fault.

Troubleshooting

Fault/Behavior	Possible causes	Test/Check	Repair
	<ol style="list-style-type: none"> 3. Photoelectric barrier defective or misaligned. 	<ol style="list-style-type: none"> 3. Check LED on the photoelectric barrier and "Safety" LED on the controller housing. 	<ol style="list-style-type: none"> 3. Align the transmitter and receiver to each other or replace.
<p>Drive stops while the door is opening.</p>	<ol style="list-style-type: none"> 1. Door contacted an obstacle. 	<ol style="list-style-type: none"> 1. Check the area of the door's motion for possible object present. 	<ol style="list-style-type: none"> 1. Remove object.
<p>Drive opens the door and then gives no reaction to commands from the remote control or the wall station (accessory).</p>	<ol style="list-style-type: none"> 1. Photoelectric barrier was interrupted. 	<ol style="list-style-type: none"> 1. "Safety" LED on the controller housing is lit. Check the area of the door's motion for possible object present. 	<ol style="list-style-type: none"> 1. Remove object.
	<ol style="list-style-type: none"> 2. Photoelectric barrier defective or misaligned. 	<ol style="list-style-type: none"> 2. Check LED on the photoelectric barrier and "Safety" LED on the controller housing. 	<ol style="list-style-type: none"> 2. Align the transmitter and receiver to each other or replace.
	<ol style="list-style-type: none"> 3. End switch "CLOSE door" in the carriage defective. 	<ol style="list-style-type: none"> 3. a) Unlock drive and slide the carriage to the middle of the running rail b) Lock the drive. c) Operate the hand-held remote control or the wall station. If the drive now still does not open and close the door, the OPEN door end switch is defective. 	<ol style="list-style-type: none"> 3. Have the end switch replaced by a specialist.
<p>Drive closes the door and then gives no reaction to commands from the remote control or the wall station (accessory).</p>	<ol style="list-style-type: none"> 1. Photoelectric barrier was interrupted by object. 	<ol style="list-style-type: none"> 1. Check the area of the door's motion for possible object present. 	<ol style="list-style-type: none"> 1. Remove object.
	<ol style="list-style-type: none"> 2. Photoelectric barrier defective or misaligned. 	<ol style="list-style-type: none"> 2. Check LED on the photoelectric barrier and "Safety" LED on the controller housing. 	<ol style="list-style-type: none"> 2. Align the transmitter and receiver to each other or replace.
	<ol style="list-style-type: none"> 3. End switch "OPEN door" in the carriage defective. 	<ol style="list-style-type: none"> 3. a) Unlock drive and slide the carriage to the middle of the running rail b) Lock the drive. c) Operate the hand-held remote control or the wall station. If the drive now still does not close and open the door, the OPEN door end switch is defective. 	<ol style="list-style-type: none"> 3. Have the end switch replaced by a specialist.

Troubleshooting

Fault/Behavior	Possible causes	Test/Check	Remedy
Speed varies for opening and closing.	<ol style="list-style-type: none"> 1. Drive starts slowly and then accelerates. 2. C-rail dirty. 3. Chain lubricated with incorrect oil. 4. Chain tightened incorrectly. 	<ol style="list-style-type: none"> 1. – 2. – 3. – 4. – 	<ol style="list-style-type: none"> 1. Immediate running, normal procedure. 2. Clean the chain and C-rail and lubricate again. See chapter “Maintenance” 3. Clean the chain and C-rail and lubricate again. See chapter “Maintenance” 4. Tighten the chain, see chapter “Installation”.
“Radio” LED on the controller housing is permanently lit.	<ol style="list-style-type: none"> 1. Continuous signal from hand-held transmitter. Button possibly jammed. 	<ol style="list-style-type: none"> 1. Check all programmed hand-held transmitters. 	<ol style="list-style-type: none"> 1. Remove the battery from the hand-held transmitter.
“Status” LED on the controller housing is permanently lit.	<ol style="list-style-type: none"> 1. Displays that voltage is mains voltage is present. 	<ol style="list-style-type: none"> 1. – 	<ol style="list-style-type: none"> 1. Normal display.
“Safety” LED on the controller housing is permanently lit.	<ol style="list-style-type: none"> 1. Photoelectric barrier defective or misaligned. 2. Wire break in the supply line. 3. Photoelectric barrier connection cable incorrectly inserted into the connection terminal. 	<ol style="list-style-type: none"> 1. – 2. Check cable paths. 3. Pull lightly on the cable. 	<ol style="list-style-type: none"> 1. Set the photoelectric barrier, exchange or remove object from the monitoring area. 2. Repair or replace the cable. 3. Reinsert the cable into the terminal.
“Command” LED on the controller housing is permanently lit.	<ol style="list-style-type: none"> 1. Continuous signal from wall station (accessory). Button possibly jammed. 2. Continuous signal of a hand-held transmitter present. 3. Continuous signal of an interfering device, e.g. a mobile phone or baby monitor. 4. Drive locked by the wall station. 	<ol style="list-style-type: none"> 1. Check the buttons on the wall station (accessory). 2. Check all hand-held transmitter for correct functioning, “Radio” LED is not continuously lit or blinking. 3. Continuously lit or blinking “Radio” LED, check the frequencies with radio scanner. 4. LED on the wall station lit up red. 	<ol style="list-style-type: none"> 1. Exchange the wall station (accessory). 2. Remove the battery, see “Troubleshooting” and exchange the hand-held transmitter. 3. – 4. Press the button (locking) on the wall station for 5 seconds until the LED lights up green.

Troubleshooting

Photoelectric barrier fault indicators

Fault display		Possible Reasons	Test/Check	Remedy
Sender (green LED)	Receiver (red LED)			
Off	Off	Drive unoperative.	Check the line circuit breaker or fuse for the circuit or check the power plug.	Switch on the the line circuit breaker or fuse for the circuit or plug in the power plug.
		Cable broken.	Check the cable for a short circuit and breakage.	Repair or replace the cable.
Blinks	Off	Cable to receiver broken.	Check the cable to the receiver for a short circuit and breakage.	Exchange or repair the cable to the receiver.
		Receiver defective.	Have the receiver checked by a specialist.	Have the receiver replaced by a specialist.
Off	Blinks	Cable to transmitter broken.	Check the cable to the transmitter for a short circuit and breakage.	Exchange or repair the transmitter.
		Transmitter defective.	Have the transmitter checked by a specialist.	Have the transmitter replaced by a specialist.
Blinks 2 x	Blinks	Transmitter and receiver not correctly aligned to each other.		Align the transmitter and receiver to each other.
		Light path interrupted.		Remove the object from the monitoring path.
Blinks	Blinks	Transmitter or receiver defective.	Have the transmitter and receiver checked by a specialist.	Have the transmitter and receiver replaced by a specialist.
Blinks	Blinks 3 x	Receiver defective or faulty connection to the drive.	Check connection.	Have the receiver possibly replaced by a specialist.

Troubleshooting

Troubleshooting

Only use original manufacturer replacement parts, accessories and mounting material.

Replacing light bulbs

⚠ WARNING

There is the risk of injury or death through electrical voltage if you accidentally reach into the lamp socket when the drive is switched on.

You must disconnect the drive from the power supply before you replace the light bulb. Pull out the power plug from the power outlet or switch off the the on-site circuit breaker or disconnect the on-site fuse for the circuit that supplies the drive with voltage. Subsequently test to be sure the drive is disconnected from the power by switching it on (the drive must not move).

CAUTION

There is the risk that the drive can be damaged or catch fire if you use stronger or larger light bulbs than approved.

Use only the light bulbs specified in this manual.

The opener lighting consists of two light bulbs (each maximum 60 W, maximum 110 V, socket E26).

- Pull the power plug out of the power outlet.
Or for a direct connection to the power mains:
- Disconnect the opener from the power (switch off the circuit breaker to the opener or disconnect the fuse on the circuit supplying the opener with voltage) and check to be sure no voltage is present.

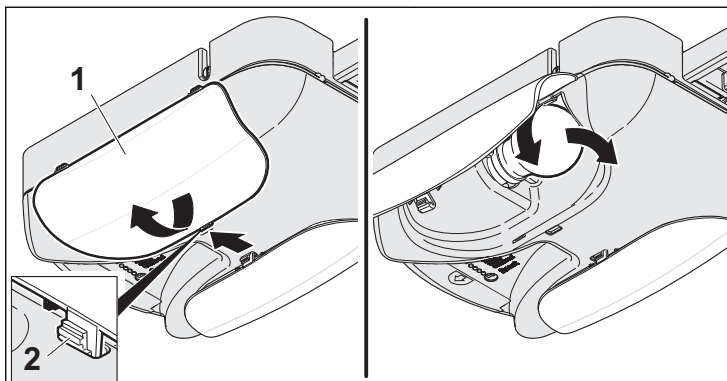

- Open a lamp lens (1). Press each of the lugs (2) in the direction of the lamp lens.
- Unscrew the light bulb in a counterclockwise direction.

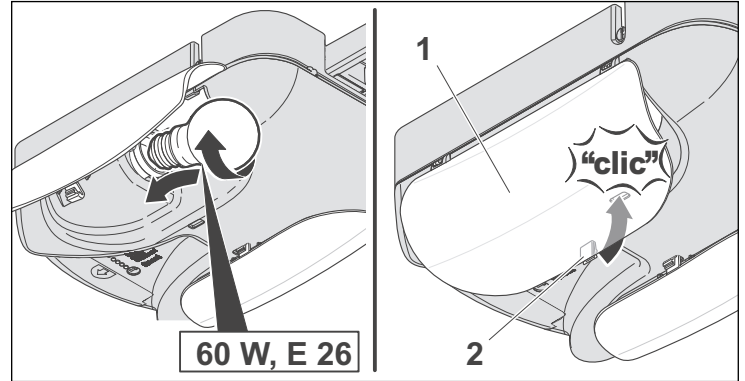

- Screw in a new light bulb in a clockwise direction.
- Close the lamp lens (1); the lugs must (2) snap into place.
- Plug in the power plug into the power outlet or
- Switch on the the electrical supply for a direct electrical connection (switch on the circuit breaker or fuse).

Replacing the drive fuse

⚠ DANGER

There is the possible risk of injury or death from electrical voltage.

You must disconnect the drive from the power supply before you replace the fuse. Pull out the power plug from the power outlet or switch off the the on-site circuit breaker or disconnect the on-site fuse for the circuit that supplies the drive with voltage. Subsequently test to be sure the drive is disconnected from the power by switching it on (the drive must not move).

CAUTION

There is the possible risk that the drive can be damaged or catch fire if you other fuses than the ones approved.

Use only the fuses specified in this manual.

- Pull the power plug out of the power outlet.
Or for a direct connection to the power mains:

Troubleshooting

- Disconnect the opener from the power (switch off the circuit breaker to the opener or disconnect the fuse on the circuit supplying the opener with voltage) and check to be sure no voltage is present.

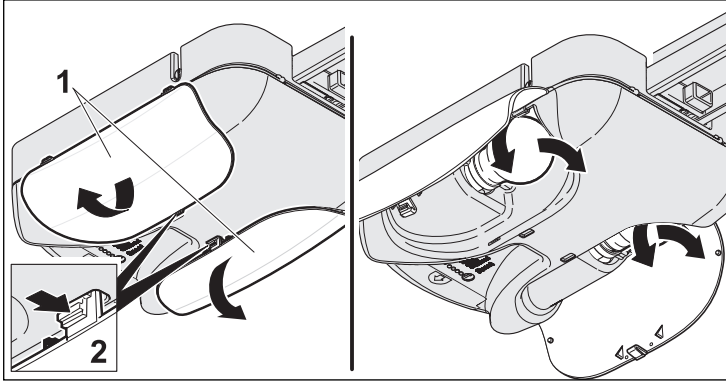

- Remove both lamp lenses (1). Press each of the lugs (2) in the direction of the lamp lens.
- Unscrew both light bulbs in a counterclockwise direction.

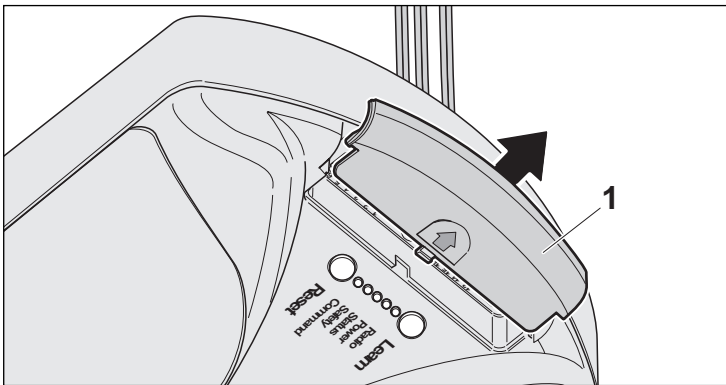

- Remove the covering (1). Slide the covering in the direction of the arrow.

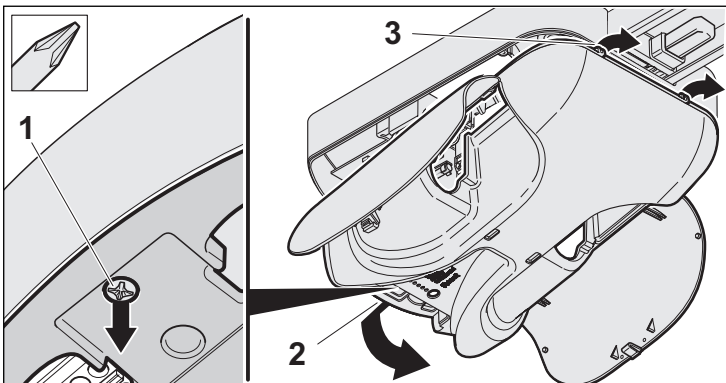

- Tighten the screw (1) with a small Phillips screwdriver.
- Open the controller housing cover downwards (2) and unhook the (3) fastening.

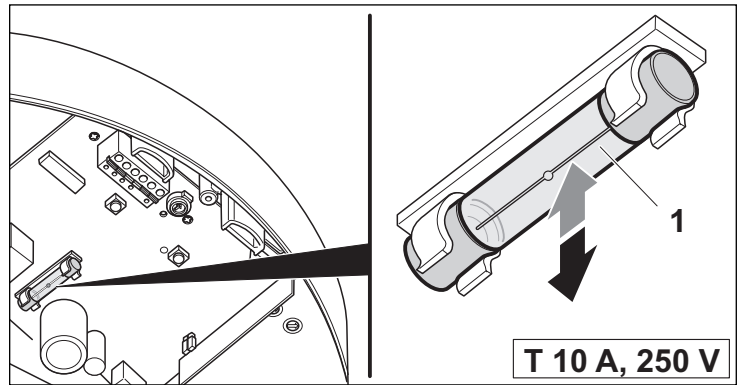

- Replace the defective fuse (1) (fuse T 10 A, 250 V). Fuse dimensions 1/4" x 1-1/4" (6.35 x 32 mm).

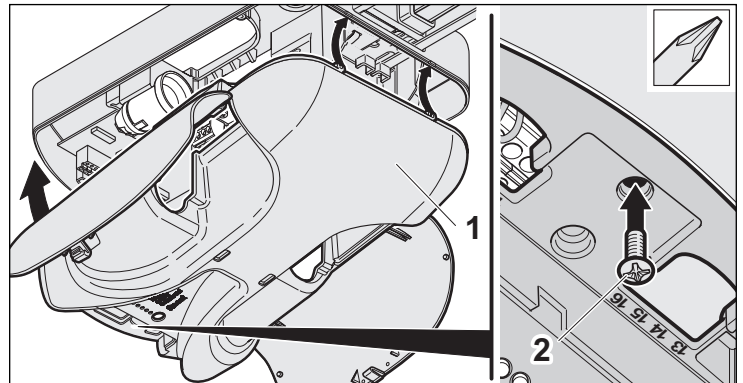

- Attach the controller housing covering (1) to the side facing the C-rail and fold it up.
- Tighten the screw (2) with a small Phillips screwdriver.

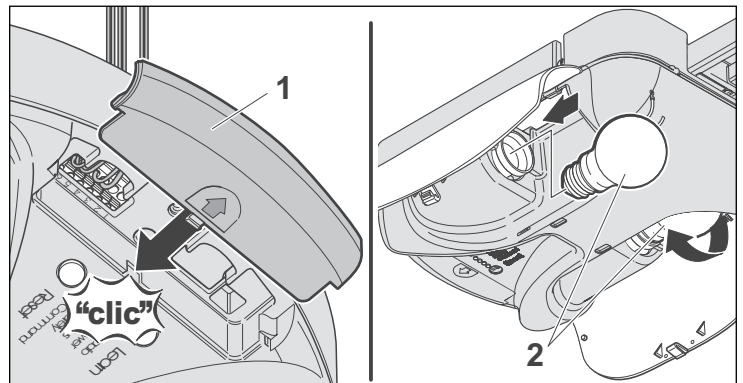

- Slid on the covering (1) in the direction of the arrow.
- Screw in both light bulbs (2) in a clockwise direction.

Troubleshooting

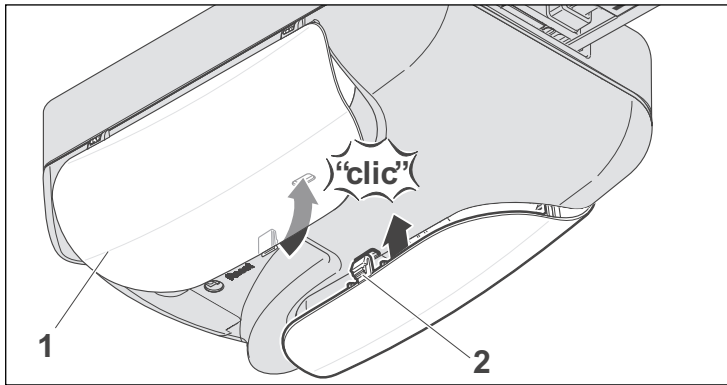

- Close both lamp lenses (1), the lug must (2) snap into place.
- Plug the power plug into the power outlet.
Or
- switch on the the electrical supply for a direct electrical connection (switch on the circuit breaker or fuse).

Replacing hand-held transmitter battery

! WARNING

There is the possible risk of injury or death if you do not observe and comply with the following information. Therefore, observe and comply with all listed instructions before handling the battery.

Do not store batteries where children can reach them. A child could play with them and accidentally swallow a battery. Call a doctor immediately if a battery is accidentally swallowed.

Never throw batteries into fire. They can explode.

Never dispose of batteries with the household waste. Leaking batteries can damage the environment. Please dispose of batteries properly according to your local regulations.

Pack the batteries individually for storage or for disposal. Batteries must never come into contact with metal objects, they can ignite, discharge, or be damaged.

Only replace batteries with the batteries specified in this manual.

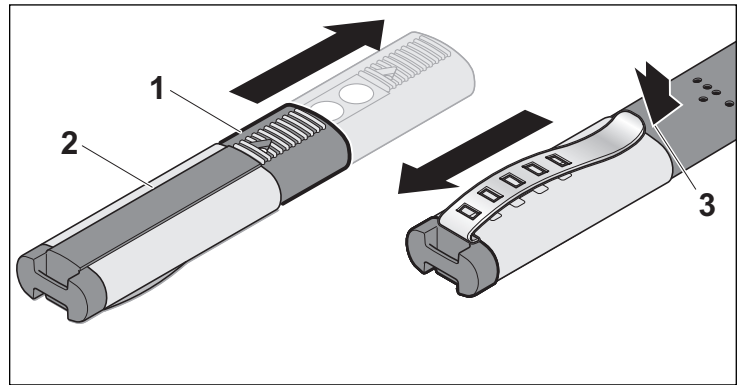

- Slide the remote control body (1) out of the stainless steel case (2) up to the stop position.
- Pull the remote control (1) completely out of the stainless steel case (2) by applying strong pressure at the location indicated in the diagram (3) (lug).

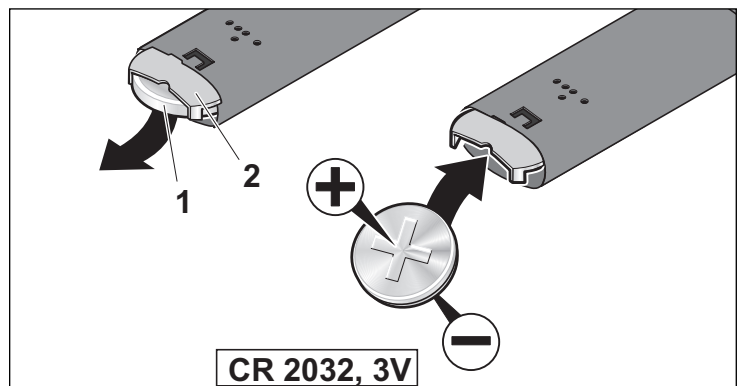

- Remove the battery (1) from the retainer (2) and install a new battery (type CR 2032, 3 V) in the same position. The side of the battery to the retainer base! (as shown in the diagram)
- Before putting back together, check whether the battery was correctly inserted:
- Press a button on the remote control. The LED must light up. If the LED does not light up, the battery must be installed in the opposite direction.

! Warning

There is a possible risk of injury when assembling the hand-held remote control. You can pinch your fingers when assembling.

Proceed carefully when inserting the remote control body into the stainless steel case.

Troubleshooting

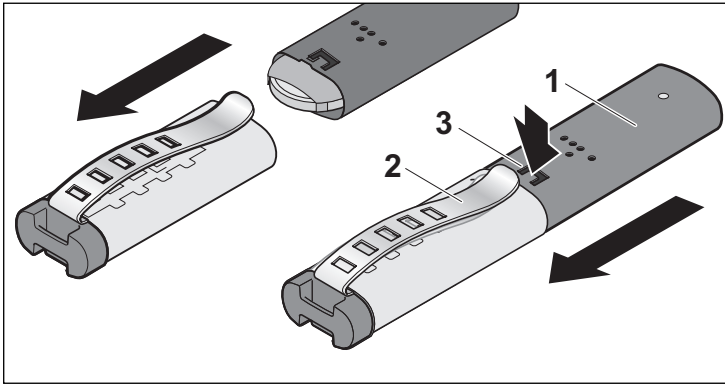

- Slide the remote control boy (1) into the stainless steel case (2). Press the lug (3) downwards.

Placing out of operation and disposal

Placing the drive out of operation

No electrical voltage may be present, if the drive and accessory parts are to be taken out of operation or deinstalled. Pull out the power plug from the power outlet or switch off the on-site circuit breaker or disconnect the on-site fuse for the circuit that supplies the drive with voltage. Subsequently test to be sure the drive is disconnected from the power by switching it on (the drive must not move). Only begin with the deinstallation after this.

Waste disposal

Please dispose of all components that have been placed out of operation properly according to your local regulations.

Battery disposal

WARNING

There is the possible risk of injury or death if you do not observe and comply with the following information. Therefore, observe and comply with all listed instructions before disposing of batteries.

Never throw batteries into fire. They can explode.

Never dispose of batteries with the household waste. Leaking batteries can damage the environment. Please dispose of batteries properly according to your local regulations.

Pack the batteries individually for disposal. Batteries must never come into contact with metal objects, they could ignite.

SOMMER in America

530 Means Street
Suite 120
Atlanta, GA 30318, USA
www.sommer-america.com

SOMMER in Germany

Antriebs- und Funktechnik GmbH

Hans-Böckler-Strasse 21-27
D-73230 Kirchheim/Teck

Telephone: 0049 (0) 7021 8001-0
Telefax: 0049 (0) 7021 8001-100

info@sommer-torantriebe.de
www.sommer.eu

© Copyright 2006 All rights reserved