

Test report No. : 29CE0014-HO-01-C-R1
Page : 17 of 89
Issued date : January 26, 2009
FCC ID : T87SS25BGXXT
Revised date : January 19, 2009

APPENDIX 1 : Photographs of test setup

UL Japan, Inc.
Head Office EMC Lab.
4383-326 Asama-cho, Ise-shi, Mie-ken 516-0021 JAPAN
Telephone : +81 596 24 8116
Facsimile : +81 596 24 8124

1. Photograph of EUT

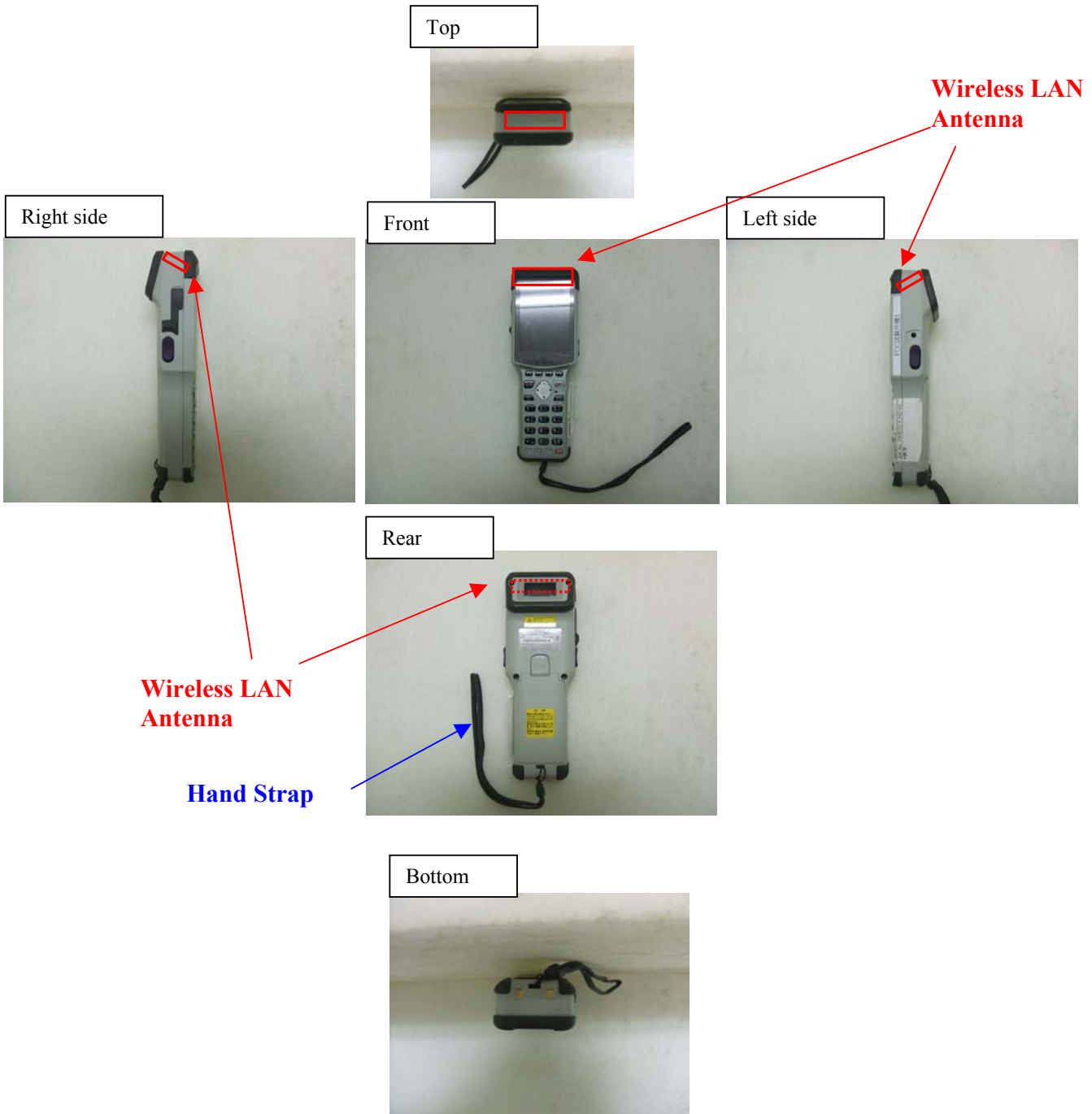

2. Antenna position



Wireless LAN
Antenna

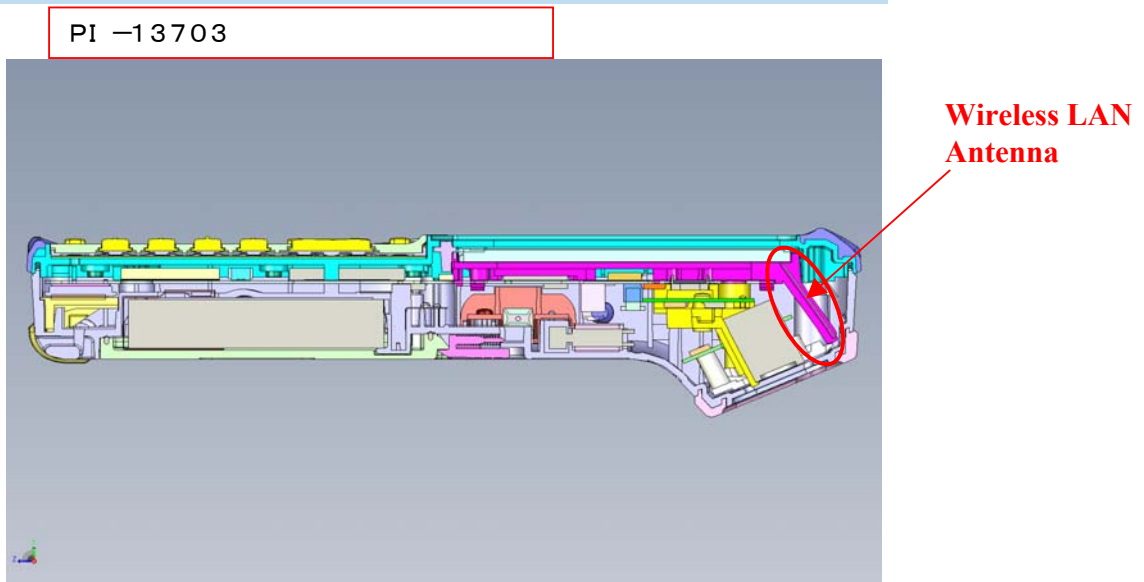
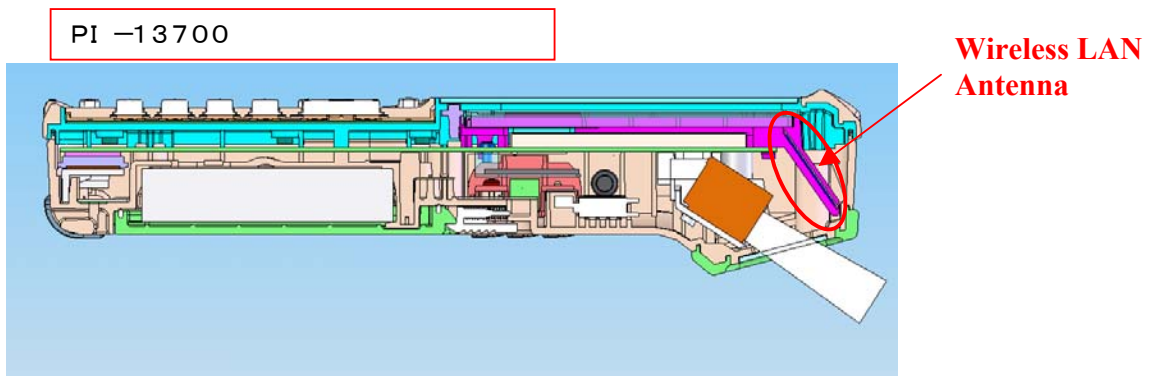

3. Size of EUT

PI -13700

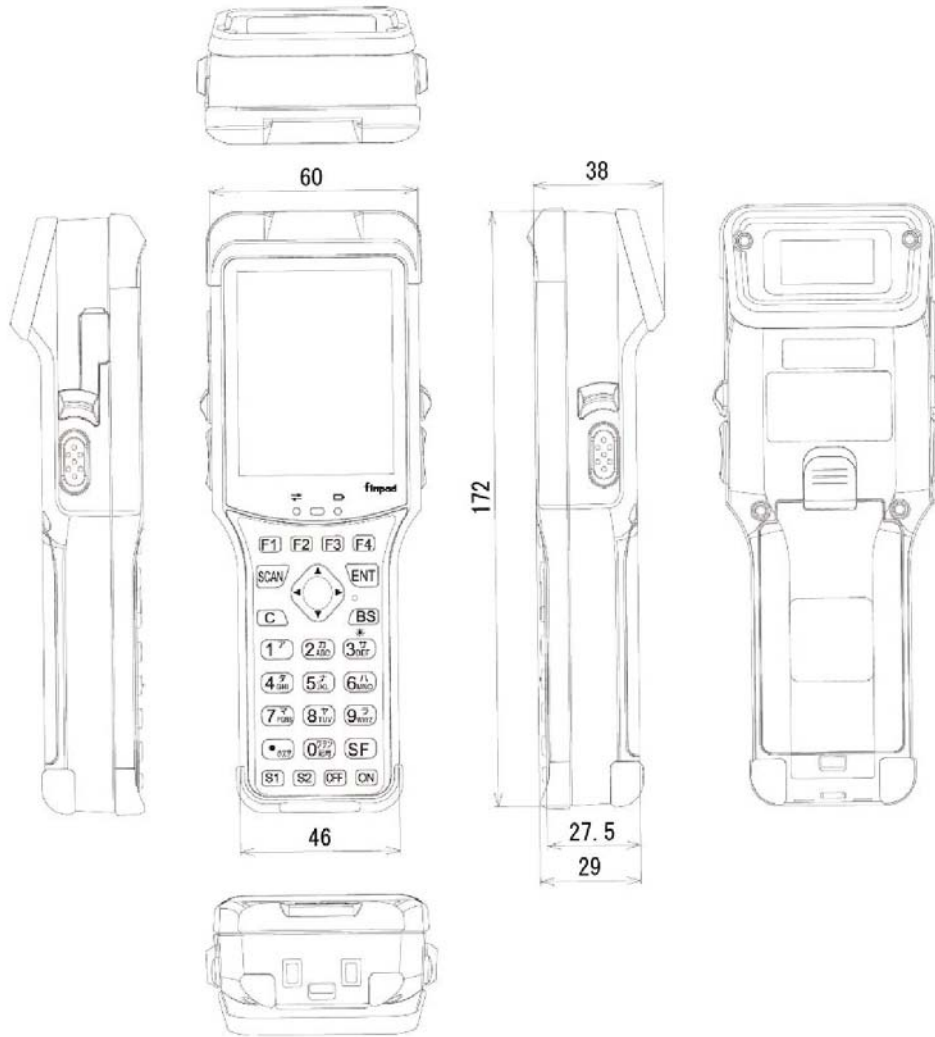

UL Japan, Inc.

Head Office EMC Lab.

4383-326 Asama-cho, Ise-shi, Mie-ken 516-0021 JAPAN

Telephone : +81 596 24 8116

Facsimile : +81 596 24 8124

PI -13703

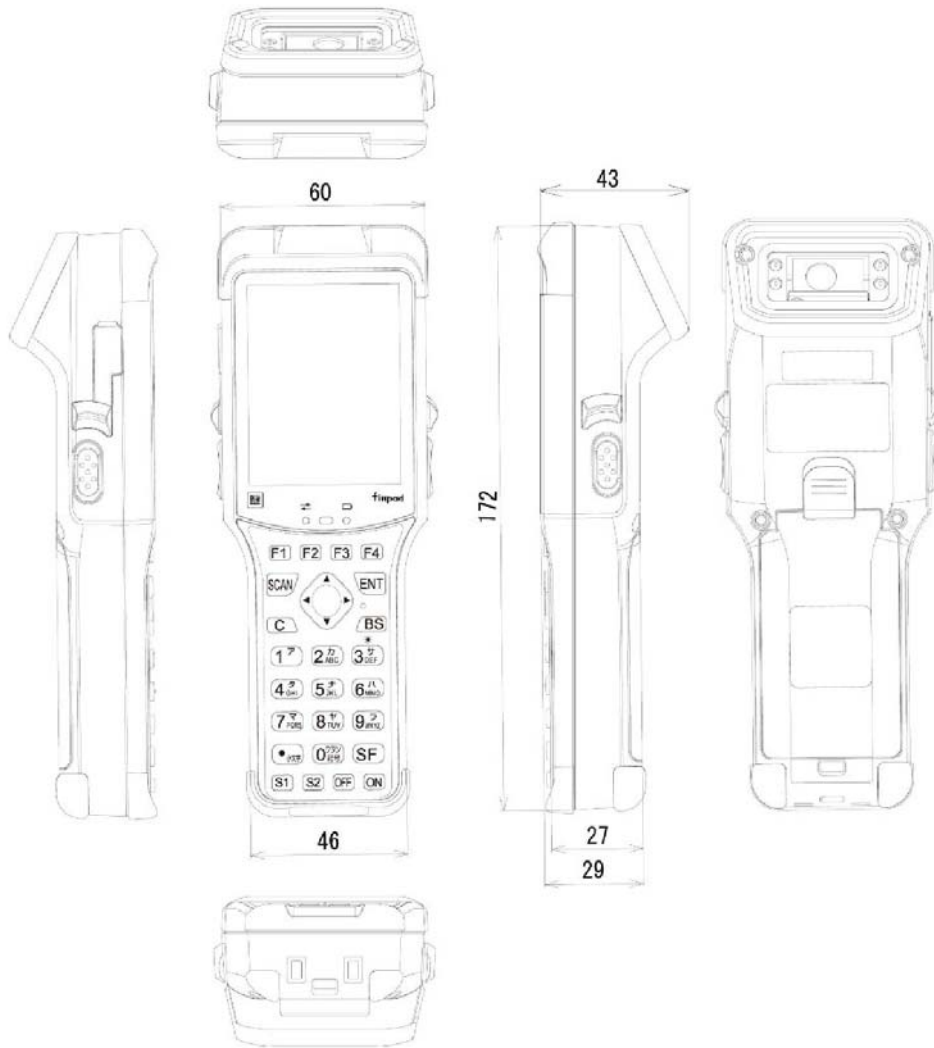

4. Photograph of test setup

(1) Front



(2) Right side

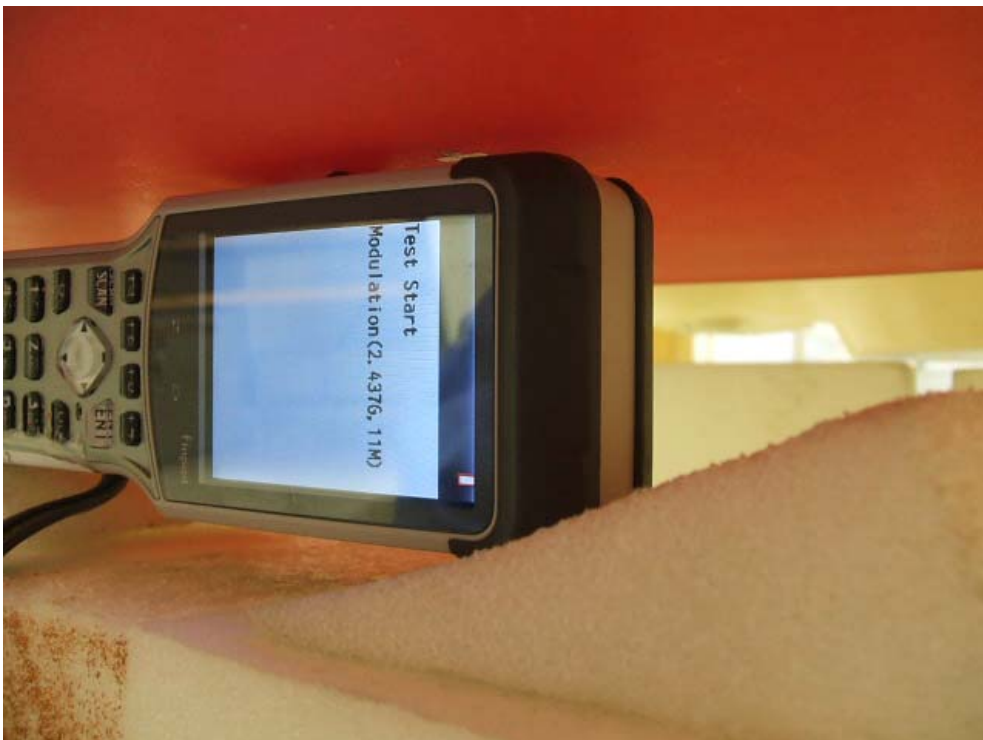

(3) Left side



UL Japan, Inc.
Head Office EMC Lab.
4383-326 Asama-cho, Ise-shi, Mie-ken 516-0021 JAPAN
Telephone : +81 596 24 8116
Facsimile : +81 596 24 8124

(4) Rear

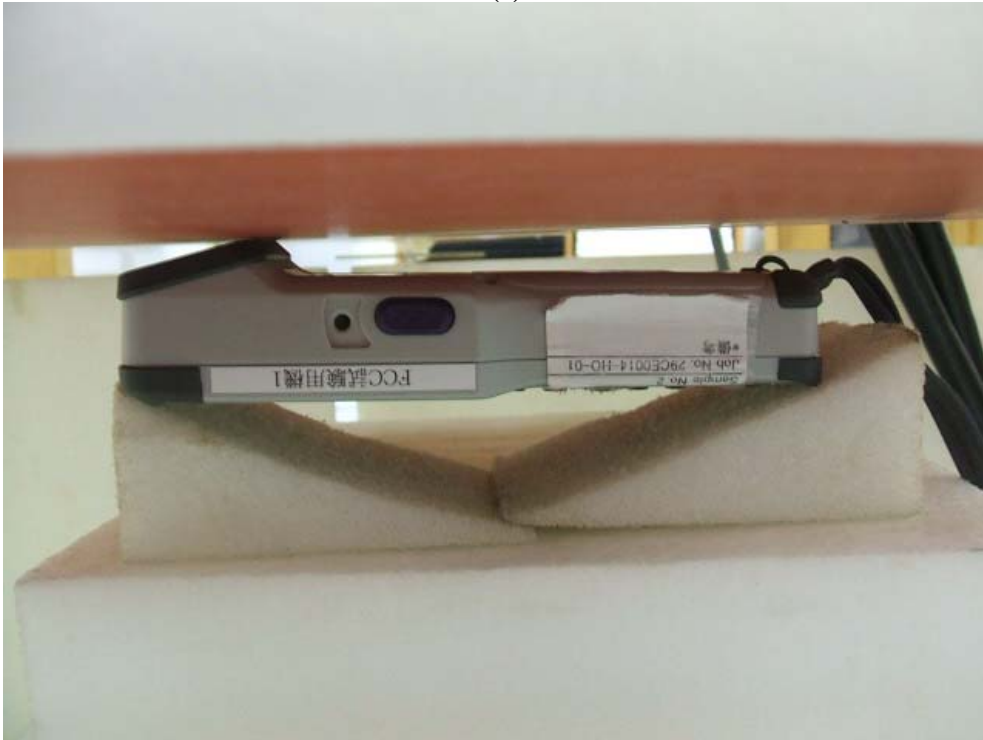

(5) Front (Separation 5mm)

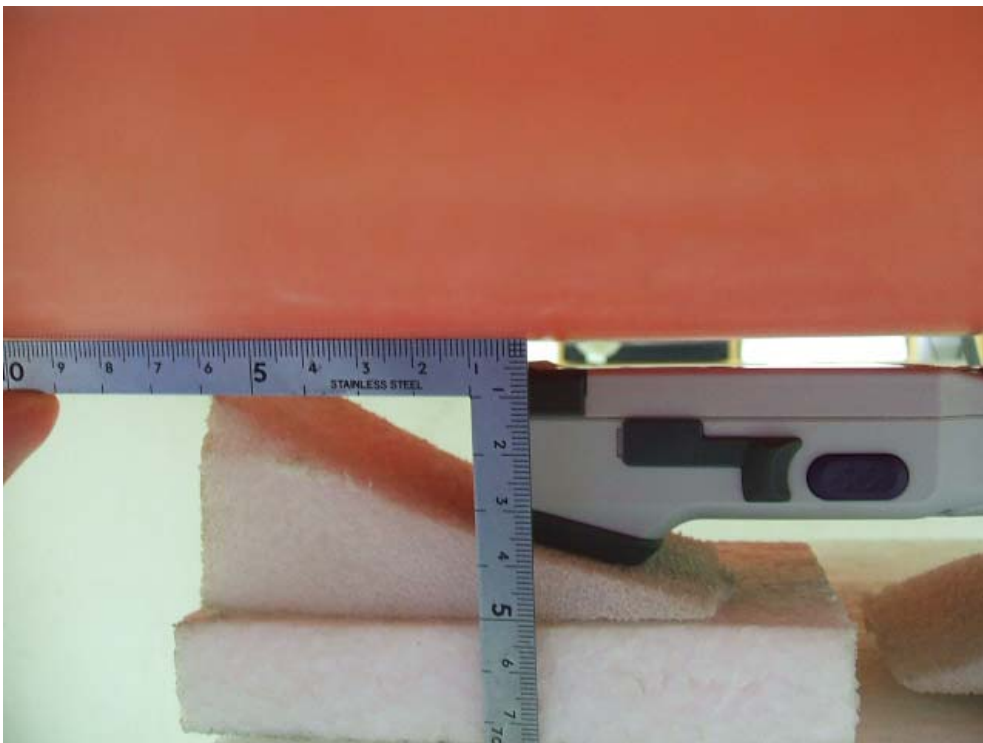

(6) Front (Separation 10mm)

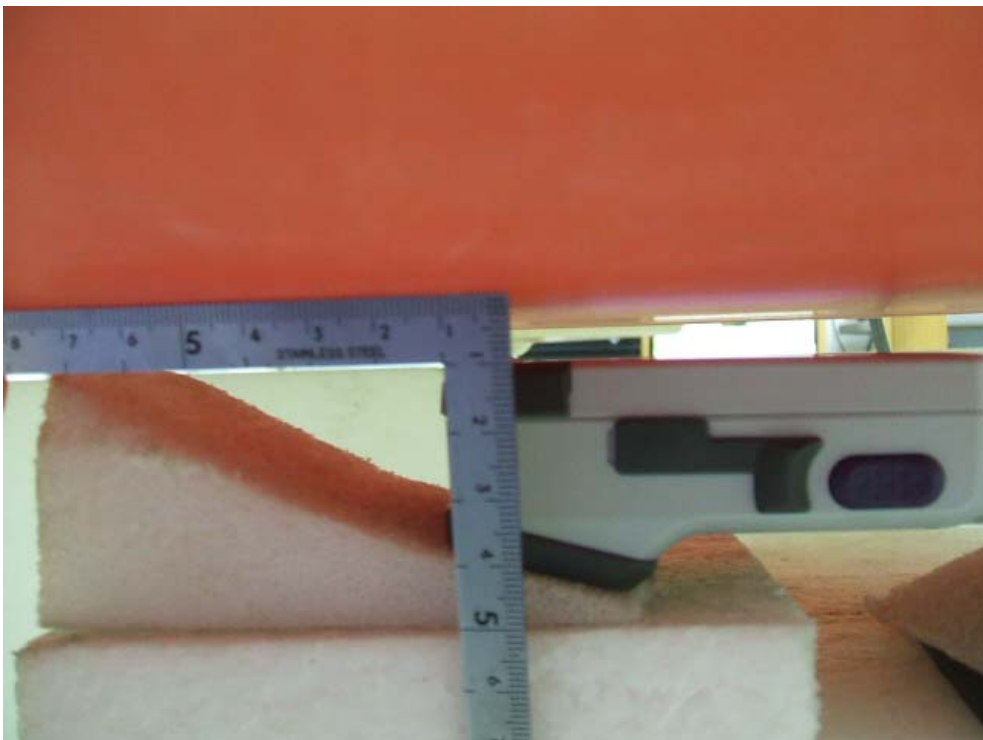

(7) Front (Separation 15mm)

