

CLASSIFICATION Einstufung	PRODUCT SPECIFICATION Produktspezifikation	No. DS-ETR2-2400-102	REV. D
SUBJECT Thema	MODEM FOR IEEE802.15.4 (ZIGBEE) "ZigBee" Modem" (IEEE802.15.4)	PAGE Seite	1 of 29
CUSTOMER'S CODE ETRX2	PANASONIC'S CODE ENWC9A0xyzE	DATE Datum	01.08.2006

Application for Production

Applicant / Manufacturer
Hardware

Panasonic Electronic Devices (Europe) GmbH
Zeppelinstrasse 19
21337 Lüneburg
Germany

Applicant / Manufacturer
Software

Ember Inc.
Telegesis (UK) Limited

Contents

Approval for Mass Production

Customer

Telegesis (UK) Limited

CHECKED / APPROVED:

DATE:	NAME:	SIGNATURE:

NOTE:

AT LEAST ONE SET OF APPROVED SPECIFICATIONS SHOULD BE RETURNED TO THE ADDRESS OF THE ISSUING PARTY.

HIGH FREQUENCY PRODUCTS DIVISION Module Business PANASONIC ELECTRONIC DEVICES (EUROPE) GmbH	APPROVED genehmigt	CHECKED geprüft	DESIGNED erstellt
--	-----------------------	--------------------	----------------------

CLASSIFICATION Einstufung	PRODUCT SPECIFICATION Produktspezifikation	No. DS-ETR2-2400-102	REV. D
SUBJECT Thema	MODEM FOR IEEE802.15.4 (ZIGBEE) "ZigBee" Modem" (IEEE802.15.4)	PAGE Seite	2 of 29
CUSTOMER'S CODE ETRX2	PANASONIC'S CODE ENWC9A0xyzE	DATE Datum	01.08.2006

TABLE OF CONTENTS

1.	Key Features	4
2.	Applications for the Module	4
3.	Description of the Module.....	5
3.1.	On board DC Regulator	5
3.2.	On Board reference Crystal	5
4.	Scope of this Document	6
5.	History for this Document.....	6
6.	Terminal Layout.....	7
7.	Block Diagram	10
8.	Key Parts List	10
9.	Test Conditions	10
10.	Absolute Maximum Ratings.....	11
11.	Operating Conditions.....	11
12.	DC Electrical Characteristics.....	12
13.	A/D converter Characteristics.....	13
14.	AC Electrical Characteristics	13
15.	Mechanical Requirements.....	15
16.	Soldering Temperature-time profile (for reflow soldering).....	16
16.1.	For lead solder	16
16.2.	For lead free solder	16
17.	Module Dimensions	17
18.	Foot Print of the Module	17
19.	Labeling Drawing.....	18
20.	Recommended Land Pattern	18
21.	Software	19
21.1.	Software Declaration.....	19
21.2.	Software Tools	19
21.3.	Ember ZigBee™ Stack.....	20
22.	Reliability Tests	20
23.	Application Notes	20
23.1.	Cautions for safety	20
23.2.	Design engineering notes	21
23.3.	Storage conditions	22
24.	Packaging.....	23
24.1.	Embossed tape / Blistergurt.....	23
24.2.	Component direction	24
24.3.	Reel dimension	24

HIGH FREQUENCY PRODUCTS DIVISION
Module Business
PANASONIC ELECTRONIC DEVICES
(EUROPE) GmbH

APPROVED
genehmigt

CHECKED
geprüft

DESIGNED
erstellt

CLASSIFICATION Einstufung	PRODUCT SPECIFICATION Produktspezifikation	No. DS-ETR2-2400-102	REV. D
SUBJECT Thema	MODEM FOR IEEE802.15.4 (ZIGBEE) "ZigBee" Modem" (IEEE802.15.4)	PAGE Seite	3 of 29
CUSTOMER'S CODE ETRX2	PANASONIC'S CODE ENWC9A0xyzE	DATE Datum	01.08.2006

24.4. Package	25
25. Ordering Information	26
26. RoHS Declaration.....	27
27. Data Sheet Status	27
28. Regulatory Information	28
28.1. FCC Notice	28
28.2. Caution.....	28
28.3. Labeling Requirements	28
28.4. Antenna Warning	29
28.5. Approved Antenna List.....	29
28.6. RF Exposure ETRX2	29
29. Related Documents	30
30. General Information.....	31
31. Life Support Policy	31

HIGH FREQUENCY PRODUCTS DIVISION
Module Business
PANASONIC ELECTRONIC DEVICES
(EUROPE) GmbH

APPROVED
genehmigt

CHECKED
geprüft

DESIGNED
erstellt

CLASSIFICATION Einstufung	PRODUCT SPECIFICATION Produktspezifikation	No. DS-ETR2-2400-102	REV. D
SUBJECT Thema	MODEM FOR IEEE802.15.4 (ZIGBEE) "ZigBee" Modem" (IEEE802.15.4)	PAGE Seite	4 of 29
CUSTOMER'S CODE ETRX2	PANASONIC'S CODE ENWC9A0xyzE	DATE Datum	01.08.2006

1. KEY FEATURES

Schlüsseleigenschaften

- short range 2,4GHz ISM band IEEE802.15.4 [1] compliant transceiver
- Complete system based on the ZigBee™ compliant platform EM250 that combines the transceiver with a powerful, efficient industry proven 16-bit microprocessor with comprehensive hardware supported network-level debugging features
- designed specifically for use with EmberZNet, Embers ZigBee compliant embedded mesh networking
- powerful 16-bit microprocessor
- 128k flash ROM and 5k of SRAM memory
- high Rx sensitivity of -97dBm at 1% Packet Error Rate
- 3dBm Tx maximum output power with power control over 20dB range
- Small size 20,5mm x 37,5mm x 2.8mm
- single port antenna terminal (pcb pad, U.FL socket or chip antenna versions available)
- Integrated ADC module with 12-bit resolution
- two 16-bit general purpose timers; one 16-bit sleep timer
- 17 GPIO pins with alternate functions
- two sleep modes for increased battery life
- low voltage detect/reset
- complies with ETSI EN300328 and FCC part15

2. APPLICATIONS FOR THE MODULE

Anwendungen für das Modul

- ZigBee™ FFD (full functional) and RFD (reduced functional) devices working in star and mesh networks
- Wireless sensor and actuator networks
- Remote control and wire replacement in industrial systems
- Building automation and control
- Inventory and logistics management
- HID (Human Interface Devices)
- Toys
- Home gateways

HIGH FREQUENCY PRODUCTS DIVISION
Module Business
PANASONIC ELECTRONIC DEVICES
(EUROPE) GmbH

APPROVED
genehmigt

CHECKED
geprüft

DESIGNED
erstellt

CLASSIFICATION Einstufung	PRODUCT SPECIFICATION Produktspezifikation	No. DS-ETR2-2400-102	REV. D
SUBJECT Thema	MODEM FOR IEEE802.15.4 (ZIGBEE) "ZigBee" Modem" (IEEE802.15.4)	PAGE Seite	5 of 29
CUSTOMER'S CODE ETRX2	PANASONIC'S CODE ENWC9A0xyzE	DATE Datum	01.08.2006

3. DESCRIPTION OF THE MODULE

Beschreibung des Moduls

ETRX2 contains the single chip EM250 [2] from Ember Inc., a 24MHz reference crystal and RF frontend circuitry optimized for best RF performance. As single ended RF output the module is available with integrated antenna or 50ohms or U.FL male socket [3] or 50 ohms pad terminal on the bottom of the module.

Two additional hardware options are available on request:

3.1. ON BOARD DC REGULATOR

Although the EM250 already contains a dc regulator internally, the module can be requested with an extra integrated onboard dc regulator. Some applications could benefit from this additional regulator because as of for example:

- (1) Further extension of the input voltage range or
- (2) Extended battery life by replacing the regulator within EM250 by a special ultra low quiescent current regulator or
- (3) allowing for operation on very noisy power supplies

Two different types of regulators can be chosen, a linear low dropout (LDO) type or a high efficiency switched buck regulator.

Depending on the power supply conditions of the application the optimum regulator can be selected on demand.

3.2. ON BOARD REFERENCE CRYSTAL

A second option that is available is an on board 32,768kHz crystal reference. This option is provided for applications that require a precision reference clock.

Where a precision 32,768kHz reference is already available on the applicationboard, it could be fed to pin 4 instead and this option is not needed.

Please contact the manufacturer if one of the options could be useful for your product design.

ETRX2 is used for ZigBee™ (www.zigbee.org) applications working with EmberZNet™ of Ember Inc. (www.ember.com). EmberZNet™ is a fully ZigBee™ compliant networking stack. For code development Insight Desktop™, a comprehensive integrated development environment (IDE) and C-language compiler toolchain from Ember Inc. is required. Insight Desktop™ is part of Ember development kits and can currently be purchased together with programming adaptors as EM250 jumpstart kit at a price of USD 2500,- directly from Ember Inc. (www.ember.com).

HIGH FREQUENCY PRODUCTS DIVISION Module Business PANASONIC ELECTRONIC DEVICES (EUROPE) GmbH	APPROVED genehmigt	CHECKED geprüft	DESIGNED erstellt
--	-----------------------	--------------------	----------------------

CLASSIFICATION Einstufung	PRODUCT SPECIFICATION Produktspezifikation	No. DS-ETR2-2400-102	REV. D
SUBJECT Thema	MODEM FOR IEEE802.15.4 (ZIGBEE) "ZigBee" Modem" (IEEE802.15.4)	PAGE Seite	6 of 29
CUSTOMER'S CODE ETRX2	PANASONIC'S CODE ENWC9A0xyzE	DATE Datum	01.08.2006

When using ZigBee™ technology for a product the following additional costs have to be taken into account:

- (1) Membership of the ZigBee™ alliance, as least as adopter member for US\$ 3.500,-.
- (2) The cost of a ZigBee™ product certification at a testhouse (TÜV Rheinland) ranges from approximately US\$ 4.000,- to US\$ 10.000,-, depending on the implemented software.
- (3) Products qualifying for ZigBee™ certification at the ZigBee™ alliance need a logo administration fee of US\$ 1000,- for the first product, and US\$ 500,- for each additional product.

For more details on ZigBee™ software see also part 21.

4. SCOPE OF THIS DOCUMENT Umfang dieses Dokumentes

This product specification applies to the ZigBee ready modem ENWC9A0xyzE. The last character indicates different versions (refer to part 26 Ordering Information). The used chip is the EM250 from the US company Ember Inc. www.ember.com.

Diese Produktionsunterlagen beziehen sich auf das ZigBee ready Modem ENWC9A0xyzE. Das letzte Zeichen bezeichnet verschiedene Versionen (Erklärung im Kapitel 25 Ordering Information). Der verwendete ZigBee Chip ist EM250 der US Firma Ember Inc.

5. HISTORY FOR THIS DOCUMENT Versionsverwaltung dieses Dokumentes

Revision Version	Date Datum	Modification / Remarks Änderungen / Bemerkungen
A	19.05.2006	Initial draft version .
B	20.06.2006	part 12: Note (1) modified and note (2) removed parts 1, 14: battery low detect removed, POR specifications added parts 19, 21.2: updated
C	10.07.2006	part 21.1: pin numbering correction
D	01.08.2006	Add chapter Regulatory Information, correct chapter Block Diagram and add also chapter Software Declaration, revise chapter Labeling Drawing

HIGH FREQUENCY PRODUCTS DIVISION Module Business PANASONIC ELECTRONIC DEVICES (EUROPE) GmbH	APPROVED genehmigt	CHECKED geprüft	DESIGNED erstellt
--	-----------------------	--------------------	----------------------

CLASSIFICATION Einstufung	PRODUCT SPECIFICATION Produktspezifikation	No. DS-ETR2-2400-102	REV. D
SUBJECT Thema	MODEM FOR IEEE802.15.4 (ZIGBEE) "ZigBee" Modem" (IEEE802.15.4)	PAGE Seite	7 of 29
CUSTOMER'S CODE ETRX2	PANASONIC'S CODE ENWC9A0xyzE	DATE Datum	01.08.2006

6. TERMINAL LAYOUT Anschlußbelegung

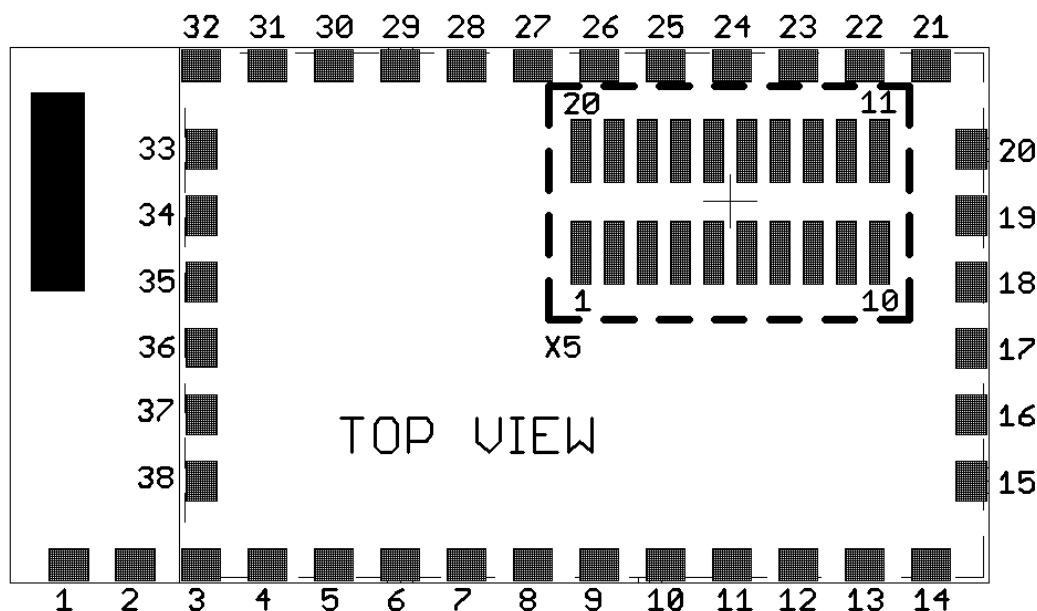

The table below informs about the 38 module pin signals for direct SMD soldering of ETRX2 to the application board. The signal names are identical to the signal names of EM250, except for RF and VC1.

The pin numbers in brackets () are the related pins of the pin/header connector X5, which is only mounted for special plug versions.

Pin No.	Pin Name	Signal Name	Pin Type	Description
1(3)	GND1	GND	I/O	ground
2	RF	RF	I/O	RF input/output terminal
3	GND3	GND	I/O	ground
4(1)	GPIO0	GPIO0 MOSI MOSI TMR1A.1	I/O O I I	Digital I/O SPI master data out of serial controller SC2 SPI slave data in of serial controller SC2 Capture Input A of Timer 1
5(2)	REG_OUT	REG_OUT	O	output of EM250 regulator voltage VREG_OUT ⁽¹⁾
6	GND2	GND	I/O	ground
7(10)	VBAT	VBAT	I	module dc supply voltage
8	GND3	GND	I/O	ground
9(4)	GPIO4	GPIO4 ADC0 PTI_EN	I/O Analog O	Digital I/O ADC Input 0 Frame signal of Packet Trace Interface (PTI)

HIGH FREQUENCY PRODUCTS DIVISION
Module Business
PANASONIC ELECTRONIC DEVICES
(EUROPE) GmbH

APPROVED
genehmigt

CHECKED
geprüft

DESIGNED
erstellt

CLASSIFICATION Einstufung	PRODUCT SPECIFICATION Produktspezifikation	No. DS-ETR2-2400-102	REV. D
SUBJECT Thema	MODEM FOR IEEE802.15.4 (ZIGBEE) "ZigBee" Modem" (IEEE802.15.4)	PAGE Seite	8 of 29
CUSTOMER'S CODE ETRX2	PANASONIC'S CODE ENWC9A0xyzE	DATE Datum	01.08.2006

Pin No.	Pin Name	Signal Name	Pin Type	Description
10(5)	GPIO5	GPIO5 ADC1 PTI_DATA	I/O Analog O	Digital I/O ADC Input 1 Data signal of Packet Trace Interface (PTI)
11(6)	GPIO3	GPIO3 SSEL TMR1IB.1	I/O I I	Digital I/O SPI slave select of Serial Controller SC2 Capture Input B of Timer 1
12(7)	GPIO2	GPIO2 MSCLK MSCLK SCL TMR2IB.2	I/O O I I/O I	Digital I/O SPI master clock of Serial Controller SC2 SPI slave clock of Serial Controller SC2 I ² C clock of Serial Controller SC2 Capture Input B of Timer 2
13(8)	GPIO1	GPIO1 MISO MISO SDA TMR2IA.2	I/O I O I/O I	Digital I/O SPI master data in of Serial Controller SC2 SPI slave data out of Serial Controller SC2 I ² C data of Serial Controller SC2 Capture Input A of Timer 2
14(9)	GPIO12	GPIO12 RTS TMR2IB.1	I/O O I	Digital I/O UART RTS handshake of Serial Controller SC1 Capture Input B for Timer 2
15	GND4	GND	I/O	ground
16	SIF_CLK	SIF_CLK	I	Serial interface, clock (internal pull-down)
17	SIF_MISO	SIF_MISO	O	Serial interface, master in / slave out
18	SIF_MOSI	SIF_MOSI	I	Serial interface, master out / slave in
19	SIF_LOADB	SIF_LOADB	I/O	Serial interface, load strobe (open-collector with internal pull-up)
20	GND5	GND	I/O	ground
21(11)	GPIO6	GPIO6 ADC2 TMR2CLK TMR1ENMSK	I/O Analog I I	Digital I/O ADC Input 2 External clock input of Timer 2 External enable mask of Timer 1
22(12)	GPIO11	GPIO11 CTS MCLK TMR2IA.1	I/O I O I	Digital I/O UART CTS handshake of Serial Controller SC1 SPI master clock of Serial Controller SC1 Capture Input A of Timer 2
23(13)	GPIO13	GPIO13 TMR2OA TMR1IA.3	I/O O I	Digital I/O Waveform Output A of Timer 2 Capture Input A of Timer 1
24(14)	RESET	RESET	I	active low module reset (internal pull-up)
25(15)	GPIO14	GPIO14 TMR2OB TMR1IB.3 IRQB	I/O O I I	Digital I/O Waveform Output B of Timer 2 Capture Input B of Timer 1 External interrupt source B
26(16)		GPIO8 VREF_OUT	I/O Analog	Digital I/O ADC reference output

HIGH FREQUENCY PRODUCTS DIVISION Module Business PANASONIC ELECTRONIC DEVICES (EUROPE) GmbH	APPROVED genehmigt	CHECKED geprüft	DESIGNED erstellt
--	-----------------------	--------------------	----------------------

CLASSIFICATION Einstufung	PRODUCT SPECIFICATION Produktspezifikation	No. DS-ETR2-2400-102	REV. D
SUBJECT Thema	MODEM FOR IEEE802.15.4 (ZIGBEE) "ZigBee" Modem" (IEEE802.15.4)	PAGE Seite 9 of 29	
CUSTOMER'S CODE ETRX2	PANASONIC'S CODE ENWC9A0xyzE	DATE Datum 01.08.2006	

Pin No.	Pin Name	Signal Name	Pin Type	Description
	GPIO8	TMR1CLK TMR2ENMSK IRQA	I I I	External clock input of Timer 1 External enable mask of Timer 2 External interrupt source A
27(18)	GPIO9	GPIO9 TXD MO MSDA TMR1IA.2	I/O O O I/O I	Digital I/O UART transmit data of Serial Controller SC1 SPI master data out of Serial Controller SC1 I ² C data of Serial Controller SC2 Capture Input A of Timer 1
28(17)	GPIO10	GPIO10 RXD MI MSCL TMR1IB.2	I/O I I I/O I	Digital I/O UART receive data of Serial Controller SC1 SPI master data in of Serial Controller SC1 I ² C clock of Serial Controller SC1 Capture Input B of Timer 2
29	GND6	GND	I/O	ground
30(19)	GPIO15	GPIO15 TMR1OA TMR2IA.3 IRQC	I/O O I I	Digital I/O Waveform Output A of Timer 1 Capture Input A of Timer 2 External interrupt source C
31(20)	GPIO16	GPIO16 TMR1OB TMR2IB.3 IRQD	I/O O I I	Digital I/O Waveform Output B of Timer 1 Capture Input B of Timer 2 External interrupt source D
32	GND7	GND	I/O	ground
33	VC1	TX_ACTIVE	O	Logic-level control for external Rx/Tx switch
34	GND8	GND	I/O	ground
35	GND9	GND	I/O	ground
36	GND10	GND	I/O	ground
37	GND11	GND	I/O	ground
38	GPIO7	GPIO7 ADC3 REG_EN	I/O Analog O	Digital I/O ADC Input 3 External regulator open collector output

Notes:

- (1) In case the onboard regulator option is mounted this pin is connected to the output voltage of the onboard regulator option and NOT to the output voltage VREG_OUT of the EM250.

HIGH FREQUENCY PRODUCTS DIVISION Module Business PANASONIC ELECTRONIC DEVICES (EUROPE) GmbH	APPROVED genehmigt	CHECKED geprüft	DESIGNED erstellt
--	-----------------------	--------------------	----------------------

CLASSIFICATION Einstufung	PRODUCT SPECIFICATION Produktspezifikation	No. DS-ETR2-2400-102	REV. D
SUBJECT Thema	MODEM FOR IEEE802.15.4 (ZIGBEE) "ZigBee" Modem" (IEEE802.15.4)	PAGE Seite	10 of 29
CUSTOMER'S CODE ETRX2	PANASONIC'S CODE ENWC9A0xyzE	DATE Datum	01.08.2006

7. BLOCK DIAGRAM Blockdiagramm

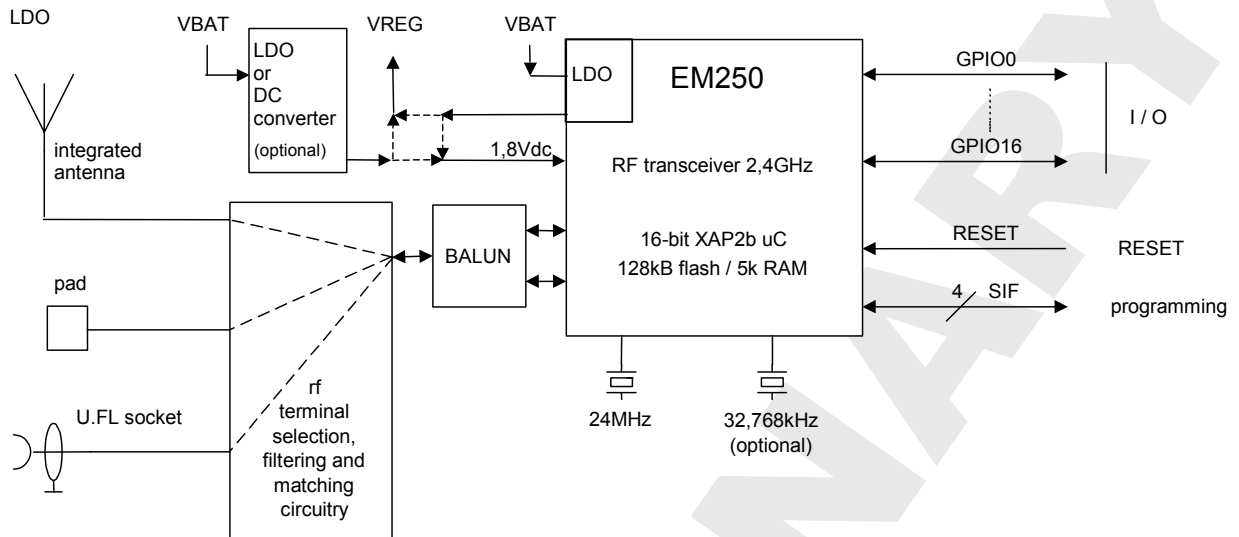

8. KEY PARTS LIST Liste der Schlüsselkomponenten

Part Name Teilenummer	Material Material
P.W.Board Leiterplatte	Glass cloth epoxide resin with gold plating FR4 mit Goldauflage
Casing Deckel	Material: CuNi18ZN20, thickness 0.2mm Material: Weißblech 0,2mm Dicke
RF-IC part name RF IC Name	EM250 from Ember Inc. (www.ember.com) All information are based on [2] chapter 28.

9. TEST CONDITIONS Meßbedingungen

Measurements shall be made under room temperature and humidity unless otherwise specified.
Messungen unter normalen Bedingungen, Abweichungen sind gesondert notiert.

Temperature	25 ± 10°C	Humidity	40 to 85%RH
Temperatur	25 ± 10°C	Luftfeuchtigkeit	40 to 85%RH

HIGH FREQUENCY PRODUCTS DIVISION
Module Business
PANASONIC ELECTRONIC DEVICES
(EUROPE) GmbH

APPROVED
genehmigt

CHECKED
geprüft

DESIGNED
erstellt

CLASSIFICATION Einstufung	PRODUCT SPECIFICATION Produktspezifikation	No. DS-ETR2-2400-102	REV. D
SUBJECT Thema	MODEM FOR IEEE802.15.4 (ZIGBEE) "ZigBee" Modem" (IEEE802.15.4)	PAGE Seite	11 of 29
CUSTOMER'S CODE ETRX2	PANASONIC'S CODE ENWC9A0xyzE	DATE Datum	01.08.2006

10. ABSOLUTE MAXIMUM RATINGS

Absolute Grenzwerte

The maximum ratings may not be exceeded under any circumstances, not even momentarily and individually, as permanent damage to the module will result.

No.	Item Punkt	Symbol Zeichen	Absolute Maximum Ratings Absolute Grenzwerte	Unit Einheit
1	Supply voltage	V_{BAT}	-0.1 to +3.6	Vdc
2	Voltage on any GPIO[16:0] , SIF_CLK, SIF_MISO, SIF_MOSI, SIF_LOADB, OSC32A, OSC32B, RESET, REG_OUT	V_{in}	-0.3 to $V_{BAT}+0.3$	Vdc
3	Voltage on VC1	V_{in}	2.0	Vdc
4	Storage temperature range	T_{stg}	-40 to +105	°C
5	Operating temperature range	T_{op}	-40 to +85	°C
6	Input RF level	P_{max}	0	dBm
7	ESD on any pin ⁽¹⁾ according to Human Body Model (HBM) circuit description	V_{THBM}	±2	kV
8	Lead temperature Löttemperatur	T_{Death}	T.B.D.	°C

Notes:

(1) Input must be current limited to the value specified.

11. OPERATING CONDITIONS

Betriebsbedingungen

No.	Item	Condition / Remark	Symbol	Value			Unit
				Min	Typ	Max	
1	Supply voltage	The typical value is recommended	V_{DD}	2.1	3.0	3.6	Vdc
2	RF Input Frequency		f_C	2405		2480	MHz
3	RF Input Power		P_{IN}			0	dBm
4	maximum Tx output power	Tx normal mode (2)	P_{OUT}		3		dB
5	Logic Input Voltage Low		V_{IL}	0		0.2x VBAT	V
6	Logic Input Voltage High		V_{IH}	0.8x VBAT		VBAT	V
7	SPI clock rate	The typical value is recommended	f_{SPI}			12	MHz
8	Operating temperature range		T_{op}	-40		+85	°C

HIGH FREQUENCY PRODUCTS DIVISION
Module Business
PANASONIC ELECTRONIC DEVICES
(EUROPE) GmbH

APPROVED
genehmigt

CHECKED
geprüft

DESIGNED
erstellt

CLASSIFICATION Einstufung	PRODUCT SPECIFICATION Produktspezifikation	No. DS-ETR2-2400-102	REV. D
SUBJECT Thema	MODEM FOR IEEE802.15.4 (ZIGBEE) "ZigBee" Modem" (IEEE802.15.4)	PAGE Seite 12 of 29	
CUSTOMER'S CODE ETRX2	PANASONIC'S CODE ENWC9A0xyzE	DATE Datum 01.08.2006	

12. DC ELECTRICAL CHARACTERISTICS

VBAT = 3.0V, T_{amb} = 25°C if nothing else stated

No.	Item	Condition / Remark	Symbol	Value			Unit
				Min	Typ	Max	
1	Module supply voltage VBAT		V _{BAT}	2.1	3.0	3.6	Vdc
2	Internal regulated core voltage	connected to REG_OUT pin 2 ⁽¹⁾	V _{CORE}	1.7	1.8	1.9	Vdc
3	Quiescent current, including internal RC oscillator		I _{SLEEP}			1.0	uA
4	Quiescent current, including 32,768kHz oscillator		I _{SLEEP}			1.5	uA
5	Transmit current consumption	total at +3dBm maximum output power	I _{TX}		35.5		mA
6	Transmit current consumption	total at +5dBm maximum output power at boost mode	I _{TX}		41.5		mA
7	Transmit current consumption	total at -32dBm minimum output power	I _{TX}		28		mA
8	Receive current consumption	total	I _{RX}		35.5		mA
9	Receive current consumption	total (boost mode)	I _{RX}		37.5		mA
10	External load on internal regulated core voltage	connected to REG_OUT pin 2 ⁽¹⁾	I _{REG_OUT}			2	mA
11	Input voltage for logic 0		V _{IL}	0		0.2x VBAT	Vdc
12	input voltage for logic 1		V _{IH}	0.8x VBAT		VBAT	Vdc
13	Input current for logic 0		I _{IL}			-0.5	uA
14	input current for logic 1		I _{IH}			0.5	uA
15	input pull-up resistor value		R _{IPU}		30		kΩ
16	input pull-down resistor value		R _{IPD}		30		kΩ
17	Output voltage for logic 0		V _{OL}	0		0.18x VBAT	Vdc
18	Output voltage for logic 1		V _{OH}	0.82x VBAT		VBAT	Vdc
19	Output source current (standard current pad)		I _{OHS}			4	mA
20	Output sink current (standard current pad)		I _{OLS}			4	mA
21	Output source current (high current pad: GPIO[16:13])		I _{OHH}			8	mA
22	Output sink current (high current pad: GPIO[16:13])		I _{OLH}			8	mA
23	Total output current for I/O pads		I _{OH} + I _{OL}			40	mA
24	Input voltage threshold for OSC32A		V _{IH_L}	0.2		0.8x VBAT	Vdc
25	Output voltage level for VC1		V _{OH_L}	0.18x VBAT		0.82x VBAT	Vdc

HIGH FREQUENCY PRODUCTS DIVISION
Module Business
PANASONIC ELECTRONIC DEVICES
(EUROPE) GmbH

APPROVED
genehmigt

CHECKED
geprüft

DESIGNED
erstellt

CLASSIFICATION Einstufung	PRODUCT SPECIFICATION Produktspezifikation	No. DS-ETR2-2400-102	REV. D
SUBJECT Thema	MODEM FOR IEEE802.15.4 (ZIGBEE) "ZigBee" Modem" (IEEE802.15.4)	PAGE Seite	13 of 29
CUSTOMER'S CODE ETRX2	PANASONIC'S CODE ENWC9A0xyzE	DATE Datum	01.08.2006

Notes:

- (1) For more information about the internal regulated core voltage refer to part 5.7 in [2]. As the internal regulated core voltage at REG_OUT mainly feeds circuitry on ETRX2, the REG_OUT module pin may only be slightly loaded and without feeding noise to REG_OUT. In case the dc regulator option is mounted REG_OUT is connected to the regulator option output instead and the internal regulated core voltage is not accessible.

13. A/D CONVERTER CHARACTERISTICS

No	Item	
1	ATD characteristics	refer to datasheet EM250 part 5.5 ADC Module
2	ATD timing/performance characteristics	refer to datasheet EM250 part 5.5 ADC Module

14. AC ELECTRICAL CHARACTERISTICS

VBAT = 3.0V, T_{amb} = 25°C, measured at 50Ω terminal load ⁽¹⁾

No	Receiver	Limit			Unit
		Min	Typ	Max	
1	Sensitivity for 1% Packet Error Rate (PER)	-85	-96	-	dBm
2	Sensitivity for 1% Packet Error Rate (PER) (boost mode)	-85	-97	-	dBm
3	Saturation (maximum input level for correct operation, low gain)	0	-	-	dBm
4	Adjacent Channel Rejection (1% PER and desired signal -82dBm acc. to [1])		35		dB
5	Alternate Channel Rejection (1% PER and desired signal -82dBm acc. to [1])		40		dB
6	Channel Rejection for all other channels (1% PER and desired signal -82dBm acc. to [1])		40		dB
7	802.11g rejection centered at +12MHz or -13MHz (1% PER and desired signal -82dBm acc. to [1])		40		dB
8	Co-channel rejection (1% PER and desired signal -82dBm acc. to [1])		-6		dBc
9	Relative frequency error (2x40ppm required by [1])	-120		120	ppm
10	Relative timing error (2x40ppm required by [1])	-120		120	ppm
11	Linear RSSI range	40			dB
12	Spurious Emissions <1GHz	-	TBD	-57	dBm
13	Spurious Emissions >1GHz	-	TBD	-47	dBm

Notes:

- (1) At pin 38 RF or U.FL socket, for all channels number 11,12,..., 26 according to [1]

HIGH FREQUENCY PRODUCTS DIVISION Module Business PANASONIC ELECTRONIC DEVICES (EUROPE) GmbH	APPROVED genehmigt	CHECKED geprüft	DESIGNED erstellt
--	-----------------------	--------------------	----------------------

CLASSIFICATION Einstufung	PRODUCT SPECIFICATION Produktspezifikation	No. DS-ETR2-2400-102	REV. D
SUBJECT Thema	MODEM FOR IEEE802.15.4 (ZIGBEE) "ZigBee" Modem" (IEEE802.15.4)	PAGE Seite 14 of 29	
CUSTOMER'S CODE ETRX2	PANASONIC'S CODE ENWC9A0xyzE	DATE Datum 01.08.2006	

No	Transmitter	Limit			Unit
		Min	Typ	Max	
14	Output power at highest power setting normal mode	0	3		dBm
15	Output power at highest power setting boost mode		N.A.(2)		dBm
16	Output power at lowest power setting normal mode		-32		dBm
17	Error vector magnitude		15	35	%
18	Carrier frequency error	-40		40	ppm
19	PSD mask relative 3.5MHz distance from carrier	-20			dB
20	PSD mask absolute 3.5MHz distance from carrier	-30			dBm
21	2 nd harmonic at highest power setting normal mode	-	-55	-30	dBm
22	3 rd harmonic at highest power setting normal mode	-	-55	-30	dBm
23	2 nd harmonic at highest power setting boost mode	-	-50	-30	dBm
24	3 rd harmonic at highest power setting boost mode	-	-50	-30	dBm
25	Spurious Emissions <1GHz	-	< -54	-36	dBm
26	Spurious Emissions >1GHz	-	< -60	-30	dBm

Notes:

- (2) Tx boost mode setting is not allowed for this version with integrated antenna and compliance with [1]

No	Standby	Limit			Unit
		Min	Typ	Max	
27	Spurious Emissions <1GHz	-	TBD	-57	dBm
28	Spurious Emissions >1GHz	-	TBD	-47	dBm

No	Sythesizer characteristics	Limit			Unit
		Min	Typ	Max	
29	Lock time from off state, with correct VCO DAC settings			100	uS
30	Relock time, channel change or Rx/Tx turnaround			100	us

HIGH FREQUENCY PRODUCTS DIVISION
Module Business
PANASONIC ELECTRONIC DEVICES
(EUROPE) GmbH

APPROVED
genehmigt

CHECKED
geprüft

DESIGNED
erstellt

CLASSIFICATION Einstufung	PRODUCT SPECIFICATION Produktspezifikation	No. DS-ETR2-2400-102	REV. D
SUBJECT Thema	MODEM FOR IEEE802.15.4 (ZIGBEE) "ZigBee" Modem" (IEEE802.15.4)	PAGE Seite	15 of 29
CUSTOMER'S CODE ETRX2	PANASONIC'S CODE ENWC9A0xyzE	DATE Datum	01.08.2006

No	Power On Reset (POR) Specifications	Limit			Unit
		Min	Typ	Max	
31	V _{BAT} POR release	1.0	1.2	1.4	Vdc
32	V _{BAT} POR assert	0.5	0.6	0.7	Vdc
33	V _{CORE} POR release	1.35	1.5	1.65	Vdc
34	V _{CORE} POR hysteresis	0.08	0.1	0.12	Vdc

15. MECHANICAL REQUIREMENTS

Mechanische Anforderungen

No.	Item Punkt	Limit Grenzwerte	Condition Bedingung
1	Solderability Lötbarkeit	More than 75% of the soldering area shall be coated by solder Mehr als 75% der Lötfläche soll mit Lötpaste bedeckt sein.	Reflow soldering with recommendable temperature profile
2	Resistance to soldering heat	It shall be satisfied electrical requirements and not be mechanical damage	See chapter 16.2

HIGH FREQUENCY PRODUCTS DIVISION
Module Business
PANASONIC ELECTRONIC DEVICES
(EUROPE) GmbH

APPROVED
genehmigt

CHECKED
geprüft

DESIGNED
erstellt

CLASSIFICATION Einstufung	PRODUCT SPECIFICATION Produktspezifikation	No. DS-ETR2-2400-102	REV. D
SUBJECT Thema	MODEM FOR IEEE802.15.4 (ZIGBEE) "ZigBee" Modem" (IEEE802.15.4)	PAGE Seite	16 of 29
CUSTOMER'S CODE ETRX2	PANASONIC'S CODE ENWC9A0xyzE	DATE Datum	01.08.2006

16. SOLDERING TEMPERATURE-TIME PROFILE (FOR REFLOW SOLDERING)
Temperatur-Zeit Profil für die Reflowlötung

16.1. FOR LEAD SOLDER

**Recommended temp. profile
for reflow soldering**

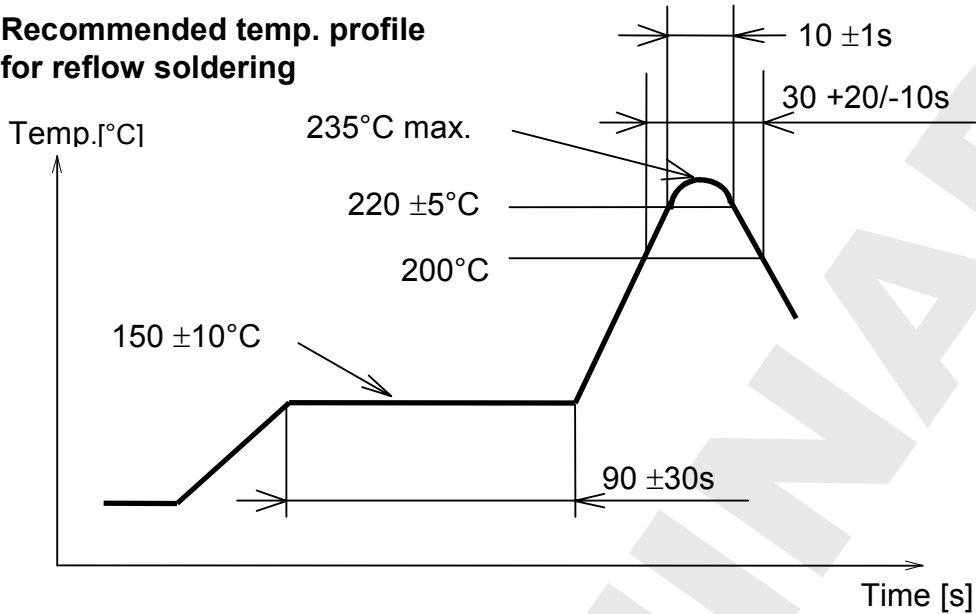

16.2. FOR LEAD FREE SOLDER

**Our used temp. profile
for reflow soldering**

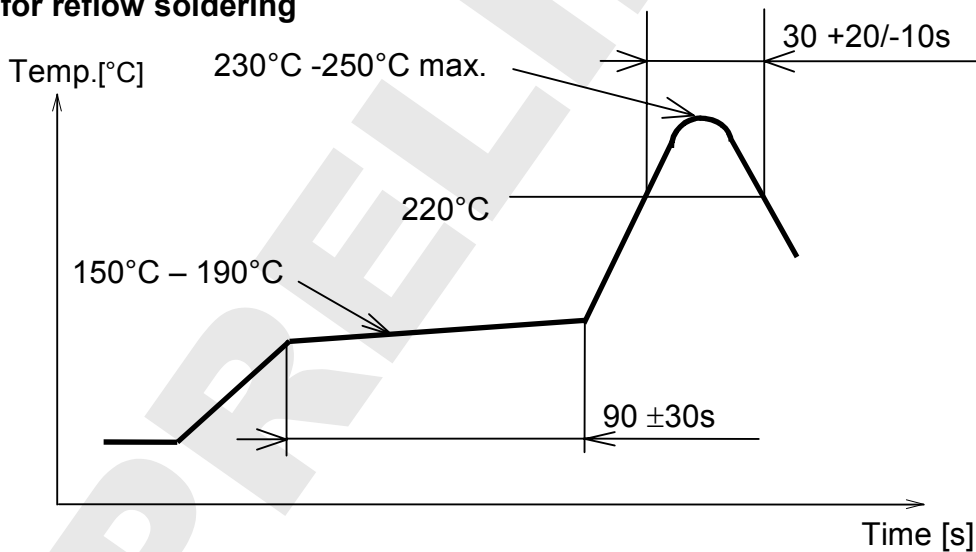

Reflow permissible cycle: 2
Opposite side reflow is prohibited due to module weight.

HIGH FREQUENCY PRODUCTS DIVISION Module Business PANASONIC ELECTRONIC DEVICES (EUROPE) GmbH	APPROVED genehmigt	CHECKED geprüft	DESIGNED erstellt
--	-----------------------	--------------------	----------------------

CLASSIFICATION Einstufung	PRODUCT SPECIFICATION Produktspezifikation	No. DS-ETR2-2400-102	REV. D
SUBJECT Thema	MODEM FOR IEEE802.15.4 (ZIGBEE) "ZigBee" Modem" (IEEE802.15.4)	PAGE Seite	17 of 29
CUSTOMER'S CODE ETRX2	PANASONIC'S CODE ENWC9A0xyzE	DATE Datum	01.08.2006

17. MODULE DIMENSIONS Modulabmessungen

No.	Item Punkt	Dimension Abmessung	Tolerance Toleranz	Remark Bemerkung
1	Width	20.50	± 0.20	
2	Lenght	37.50	± 0.20	
3	Height	2.80	± 0.10	With case

18. FOOT PRINT OF THE MODULE Löt pads vom Modul

overall measures:

L=37,5

W=20,5

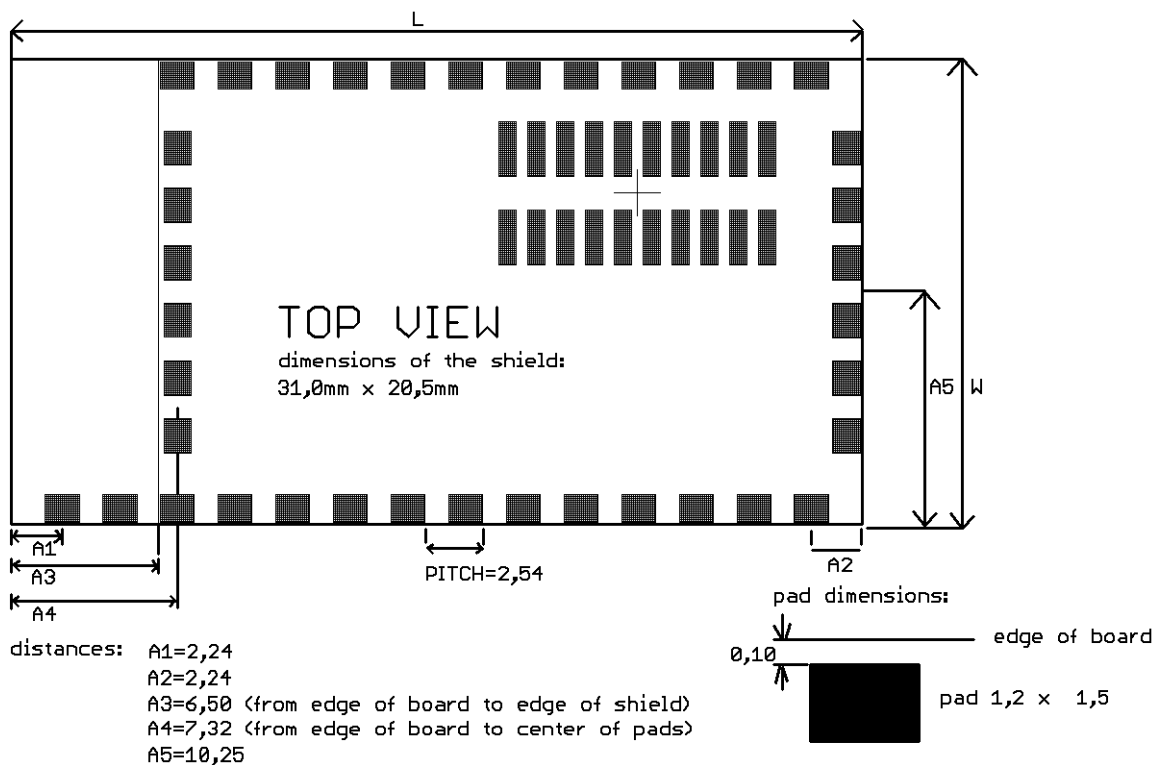

Dimensions in mm.

HIGH FREQUENCY PRODUCTS DIVISION
Module Business
PANASONIC ELECTRONIC DEVICES
(EUROPE) GmbH

APPROVED
genehmigt

CHECKED
geprüft

DESIGNED
erstellt

CLASSIFICATION Einstufung	PRODUCT SPECIFICATION Produktspezifikation	No. DS-ETR2-2400-102	REV. D
SUBJECT Thema	MODEM FOR IEEE802.15.4 (ZIGBEE) "ZigBee" Modem" (IEEE802.15.4)	PAGE Seite	18 of 29
CUSTOMER'S CODE ETR2	PANASONIC'S CODE ENWC9A0xyzE	DATE Datum	01.08.2006

19. LABELING DRAWING

Kennzeichnung des Moduls durch Label



The label dimensions are 13,0mm x 18,5 mm. It is suited for reflow soldering.

Imprint Aufdruck	Description Beschreibung
ETR2	This is the marketing name from Telegesis, the ENW number is only integrated in the 2D Code and marked with the Z
Date Code	Production Date Code in the format YYMMDD, e.g. 060602
01	Indication for software revision for our final test, customer are able to flash there own software.
01Z	Indication for the hardware revision, Z indicates the ES status, will be removed after MP ready.
0000001	Indication for the serial number.
FCC ID: T7VEM250A	This is the FCC ID, should be labelled only after FCC approval.
2D-Barcode	Information in the 2D-Barcode are the serial number [7 signs], the ENW-Part-Number [11 signs], identifier for the software release [2 signs], the identifier for the hardware release [2 signs] and the production date code in the format Year-Month-Day [6 signs], separated by a semicolon. The IEEE802.15.4 MAC Address [12 characters] are stored in the EM250, therefore it could not be on the label, but must be stored in the excel sheet to have a reference between MAC address and serial number.

20. RECOMMENDED LAND PATTERN

Empfohlenes Land Pattern

This part will be included in next revisions.

HIGH FREQUENCY PRODUCTS DIVISION Module Business PANASONIC ELECTRONIC DEVICES (EUROPE) GmbH	APPROVED genehmigt	CHECKED geprüft	DESIGNED erstellt
--	-----------------------	--------------------	----------------------

CLASSIFICATION Einstufung	PRODUCT SPECIFICATION Produktspezifikation	No. DS-ETR2-2400-102	REV. D
SUBJECT Thema	MODEM FOR IEEE802.15.4 (ZIGBEE) "ZigBee" Modem" (IEEE802.15.4)	PAGE Seite	19 of 29
CUSTOMER'S CODE ETRX2	PANASONIC'S CODE ENWC9A0xyzE	DATE Datum	01.08.2006

21. SOFTWARE

Software

21.1. SOFTWARE DECLARATION

With the signature on the front page, customer clearly understand and agreed that the software, which is included in the module is only for testing purpose and Panasonic deny any responsibility for product liability, related to software matters.

21.2. SOFTWARE TOOLS

In order to develop code and ZigBee™ networks the Ember Insight Desktop Development Environment is required. This environment works with the preceding EM2420, the EM250 and the upcoming EM260. For code development it comprises the Integrated Development Environment (IDE) named xIDE based on eclipse 3.1.0 for editing, compiling and debugging of C–applications. In addition network visualization and debugging tools are included.

For programming the Ember Insight Adaptor is required. This adaptor has to be linked to the computer where the Ember Insight Desktop is installed on over an Ethernet network connection. Before connecting ETRX2 to the Ember Insight Adaptor study the latest Ember Insight Adaptor documentation. The following pins of ETRX2 have to be connected to the signals on the debug connector of the Ember Insight adaptor:

ETRX2 pin	ETRX2 signal name	Insight Adapter signal name
various	ground	ground
7(10) ⁽¹⁾	VBAT	3.0Vdc
24(14)	RESET	RSTB
16	SIF_CLK	SIF_CLK
17	SIF_MISO	SIF_MISO
18	SIF_MOSI	SIF_MOSI
19	SIF_LOADB	SIF_LOADB
as packet trace interface (PTI) also connect the following signals:		
9(4)	GPIO4	GPIO4
10(5)	GPIO5	GPIO5

Note:

- (1) Only if the Ember Insight Adaptor is set to powering the target device ETRX2. The pin numbers in brackets () are the related pins of the pin/header connector X5, which is only mounted for special plug versions.

HIGH FREQUENCY PRODUCTS DIVISION Module Business PANASONIC ELECTRONIC DEVICES (EUROPE) GmbH	APPROVED genehmigt	CHECKED geprüft	DESIGNED erstellt
--	-----------------------	--------------------	----------------------

CLASSIFICATION Einstufung	PRODUCT SPECIFICATION Produktspezifikation	No. DS-ETR2-2400-102	REV. D
SUBJECT Thema	MODEM FOR IEEE802.15.4 (ZIGBEE) "ZigBee" Modem" (IEEE802.15.4)	PAGE Seite	20 of 29
CUSTOMER'S CODE ETRX2	PANASONIC'S CODE ENWC9A0xyzE	DATE Datum	01.08.2006

21.3. EMBER ZIGBEE™ STACK

EmberZNet (currently version 2.3) is the ZigBee stack provided with EM250. It supports as networking topologies true mesh, star and cluster networks. The ZigBee devices ZigBee Coordinator, ZigBee Full Functional Device and ZigBee End Devices are supported.

For the ease of application programming EmberZNet is controlled by the application over API commands. Direct ZigBee APS layer APIs are provided for applications that require low level ZigBee control.

According to [1] each ZigBee device has a unique address. This address is provided by Ember Inc. with the EM250.

For more information on the items above see the website of Ember Inc. (www.ember.com) and the documentation included in the Ember Insight Desktop package as part of the Ember development kits.

22. RELIABILITY TESTS

Zuverlässigkeitstests

The measurement should be done after exposed to room temperature and humidity for 1hour. Die Messungen sollten erst nach einer Stunde Lagerung unter normalen Bedingungen erfolgen.

No.	Item Punkt	Limit Grenzwerte	Condition Bedingung
1	Vibration test	Electrical parameter should be in specification	a) Freq.:10~50Hz,Amplitude:1.5mm a) 20min. / cycle,1hrs. each of XYZ axis b) Freq.:30~100Hz, 6G b) 20min. / cycle,1hrs. each of XYZ axis
2	Shock test	the same as the above	Dropped onto hard wood from height of 50cm for 3 times
3	Heat cycle test	the same as the above	-40°C for 30min. and +85°C for 30min.; each temperature 300 cycles
4	Moisture test	the same as the above	+60°C, 90% RH, 300h
5	Low temp. test	the same as the above	-40°C, 300h
6	High temp. test	the same as the above	+85°C, 300h

23. APPLICATION NOTES

Applikationshinweise

23.1. CAUTIONS FOR SAFETY

Sicherheitshinweise

These specifications are intended to preserve the quality assurance of products as individual components.

Before use, check and evaluate their operation when mounted on your products. Abide by these specifications, without deviation when using the products. These products may short-circuit. If electrical shocks, smoke, fire, and/or accidents involving human life are

HIGH FREQUENCY PRODUCTS DIVISION Module Business PANASONIC ELECTRONIC DEVICES (EUROPE) GmbH	APPROVED genehmigt	CHECKED geprüft	DESIGNED erstellt
--	-----------------------	--------------------	----------------------

CLASSIFICATION Einstufung	PRODUCT SPECIFICATION Produktspezifikation	No. DS-ETR2-2400-102	REV. D
SUBJECT Thema	MODEM FOR IEEE802.15.4 (ZIGBEE) "ZigBee" Modem" (IEEE802.15.4)	PAGE Seite	21 of 29
CUSTOMER'S CODE ETRX2	PANASONIC'S CODE ENWC9A0xyzE	DATE Datum	01.08.2006

anticipated when a short circuit occurs, then at least, provide the following failsafe functions, as a minimum.

- (1) Ensure the safety of the whole system by installing a protection circuit and a protection device.
- (2) Ensure the safety of the whole system by installing a redundant circuit or another system to prevent a single fault causing an unsafe status.

23.2. DESIGN ENGINEERING NOTES

Designhinweise

- (1) Heat is the major cause of shortening the life of these products. Avoid assembly and use of the target equipment in conditions where the products' temperature may exceed the maximum allowable.
- (2) Failure to do so may result in degrading of the product's functions and damage to the product.
- (3) If pulses or other transient loads (a large load applied in a short time) are applied to the products, then before use, check and evaluate their operation when assembled on your products.
- (4) Carefully position the products so that their heat will not burn into printed circuit boards or affect the other components that are susceptible to heat.
- (5) Carefully locate these products so that their temperatures will not increase due to the effects of heat generated by neighboring components.
- (6) If a vinyl-covered wire comes into contact with the products, then the cover will melt and generate toxic gas, damaging the insulation. Never allow contact between the cover and these products to occur.
- (7) These products are intended for general purpose and standard use in general electronic equipment, such as home appliances, office equipment, information and communication equipment.
- (8) These products are not intended for other uses, other than under the special conditions shown below. Before using these products under such special conditions, check their performance and reliability under the said special conditions carefully to determine whether or not they can be used in such a manner.
- (9) In liquid, such as water, salt water, oil, alkali, or organic solvent, or in places where liquid may splash.
- (10) In direct sunlight, outdoors, or in a dusty environment
- (11) In an environment where condensation occurs.
- (12) In an environment with a high concentration of harmful gas (e.g. salty air, HCl, Cl₂, SO₂, H₂S, NH₃, and NO_x)
- (13) If an abnormal voltage is applied due to a problem occurring in other components or circuits, replace these products with new products because they may not be able to provide normal performance even if their electronic characteristics and appearances appear satisfactory.
- (14) Mechanic stress during assembly on board and operation has to be avoided.
- (15) Pressing on parts of the metal cover or fastening objects to the metal cover is not allowed.

HIGH FREQUENCY PRODUCTS DIVISION Module Business PANASONIC ELECTRONIC DEVICES (EUROPE) GmbH	APPROVED genehmigt	CHECKED geprüft	DESIGNED erstellt
--	-----------------------	--------------------	----------------------

CLASSIFICATION Einstufung	PRODUCT SPECIFICATION Produktspezifikation	No. DS-ETR2-2400-102	REV. D
SUBJECT Thema	MODEM FOR IEEE802.15.4 (ZIGBEE) "ZigBee" Modem" (IEEE802.15.4)	PAGE Seite	22 of 29
CUSTOMER'S CODE ETRX2	PANASONIC'S CODE ENWC9A0xyzE	DATE Datum	01.08.2006

23.3. STORAGE CONDITIONS

Lagerbedingungen

The module may not be stressed mechanically during storage.

Do not store these products in the following conditions or the performance characteristics of the product, such as RF performance will be adversely affected:

- (1) Storage in salty air or in an environment with a high concentration of corrosive gas, such as Cl₂, H₂S, NH₃, SO₂, or NO_X
- (2) Storage in direct sunlight
- (3) Storage in an environment where the temperature may be outside the range of 5°C to 35°C range, or where the humidity may be outside the 45 to 85% range.
- (4) Storage of the products for more than one year after the date of delivery at your company if all the above conditions (1) to (3) have been avoided.

HIGH FREQUENCY PRODUCTS DIVISION
Module Business
PANASONIC ELECTRONIC DEVICES
(EUROPE) GmbH

APPROVED
genehmigt

CHECKED
geprüft

DESIGNED
erstellt

CLASSIFICATION Einstufung	PRODUCT SPECIFICATION Produktspezifikation	No. DS-ETR2-2400-102	REV. D
SUBJECT Thema	MODEM FOR IEEE802.15.4 (ZIGBEE) "ZigBee" Modem" (IEEE802.15.4)	PAGE Seite	23 of 29
CUSTOMER'S CODE ETRX2	PANASONIC'S CODE ENWC9A0xyzE	DATE Datum	01.08.2006

24. PACKAGING Verpackung

24.1. EMBOSSED TAPE / BLISTERGURT

(1) Dimension of the tape / Abmessungen des Gurtes (EIAJ-tbd)

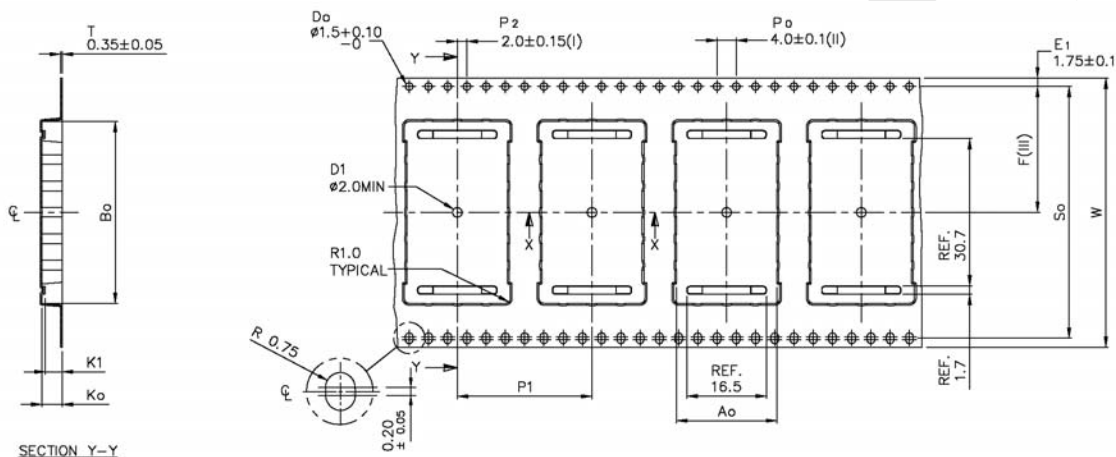

Ao	20.85 +/−0.1
Bo	37.85 +/−0.1
Ko	4.20 +/−0.1
K1	3.55 +/−0.1
F	26.20 +/−0.15
P1	28.00 +/−0.1
So	52.40 +/−0.1
W	56.00 +/−0.3

Forming format : Flatbed
Estimated max. length : 46 meter / 22B6 reel

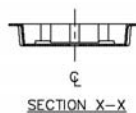

- (I) Measured from centreline of sprocket hole to centreline of pocket.
- (II) Cumulative tolerance of 10 sprocket holes is ± 0.20.
- (III) Measured from centreline of sprocket hole to centreline of pocket.

ALL DIMENSIONS IN MILLIMETRES UNLESS OTHERWISE STATED.

(2) Cover tape reel strength / Abzugskräfte Blistergurt Deckfolie

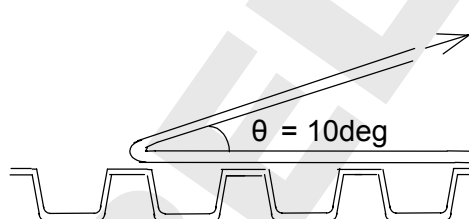

Force direction

Speed = 300mm/min.

Cover tape reel strength
= 0.098~0.68N (10~70g)

HIGH FREQUENCY PRODUCTS DIVISION
Module Business
PANASONIC ELECTRONIC DEVICES
(EUROPE) GmbH

APPROVED
genehmigt

CHECKED
geprüft

DESIGNED
erstellt

CLASSIFICATION Einstufung	PRODUCT SPECIFICATION Produktspezifikation	No. DS-ETR2-2400-102	REV. D
SUBJECT Thema	MODEM FOR IEEE802.15.4 (ZIGBEE) "ZigBee" Modem" (IEEE802.15.4)	PAGE Seite	24 of 29
CUSTOMER'S CODE ETRX2	PANASONIC'S CODE ENWC9A0xyzE	DATE Datum	01.08.2006

(3) Empty hollow / leere Taschen

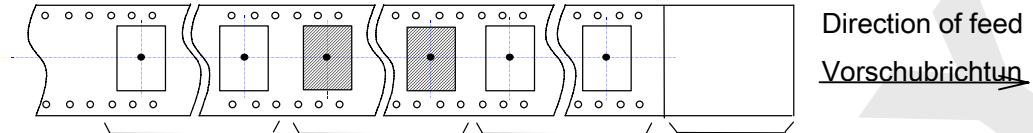

Empty hollow more than 10 pitch
Mehr als 10 leere

Component packed area
Modulbereich

Empty hollow more than 10pitch
Mehr als 10 leere

Top cover tape more than 200mm
Deckfolie groesser als

Empty hollow in component packed area shall be less than two per reel and those hollows shall not be consecutive.

Es dürfen minimal 2 leere Taschen im Bereich der Komponenten vorhanden sein, diese dürfen aber nicht aufeinander folgen.

24.2. COMPONENT DIRECTION

Komponentenanordnung

Top cover tape shall not be found on reel holes and shall not stick out from reel.

Deckfolien darf nicht durch die Löcher der Spule und nicht außerhalb der Spule geführt werden.

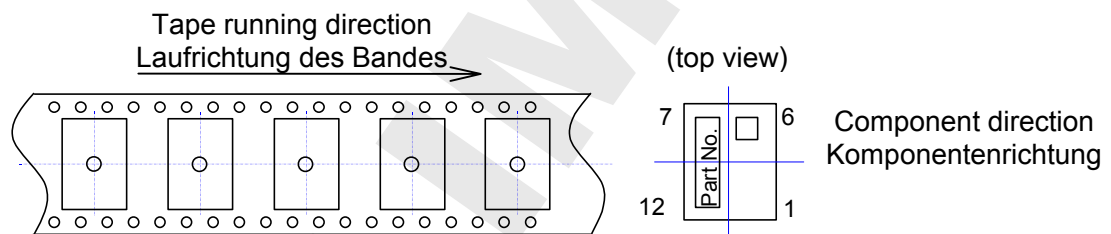

Figure 1

24.3. REEL DIMENSION

Abmaße der Rolle

- (1) Quantity per reel : 400 pieces
Anzahl pro Rolle : 400 Stück
- (2) Marking : Customer's part No. / Quantity / Lot No. and Our part# with bar-code shall be on the reel.
Kennzeichnung : Kundennummer / Anzahl / Losnummer und unsere Komponentenummer als Barcode wird auf die Rolle gedruckt
Refer to figure 2
Bezugnehmend zur Zeichnung 2

HIGH FREQUENCY PRODUCTS DIVISION Module Business PANASONIC ELECTRONIC DEVICES (EUROPE) GmbH	APPROVED genehmigt	CHECKED geprüft	DESIGNED erstellt
--	-----------------------	--------------------	----------------------

CLASSIFICATION Einstufung	PRODUCT SPECIFICATION Produktspezifikation	No. DS-ETR2-2400-102	REV. D
SUBJECT Thema	MODEM FOR IEEE802.15.4 (ZIGBEE) "ZigBee" Modem" (IEEE802.15.4)	PAGE Seite	25 of 29
CUSTOMER'S CODE ETRX2	PANASONIC'S CODE ENWC9A0xyzE	DATE Datum	01.08.2006

24.4. PACKAGE

Umverpackung

- | | |
|--------------------------------------|--|
| (1) Package box :
Paketbox.: | 1 or 2 reel (depends on quantity)
1 oder 2 Rollen (abhängig von der Liefermenge) |
| (2) Marking :

Kennzeichnung : | Customer's part No. / Quantity / Lot No. and Our part#
with bar-code shall be on the package box.
Kundennummer / Anzahl / Losnummer und unsere
Komponentennummer als Barcode wird auf die
Verpackung gedruckt
Refer to figure 2 and 3
Bezugnehmend zur Zeichnung 2 und 3 |

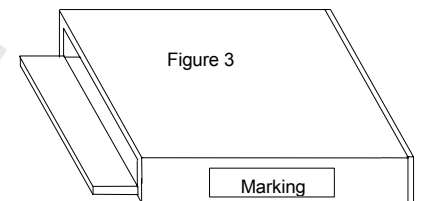
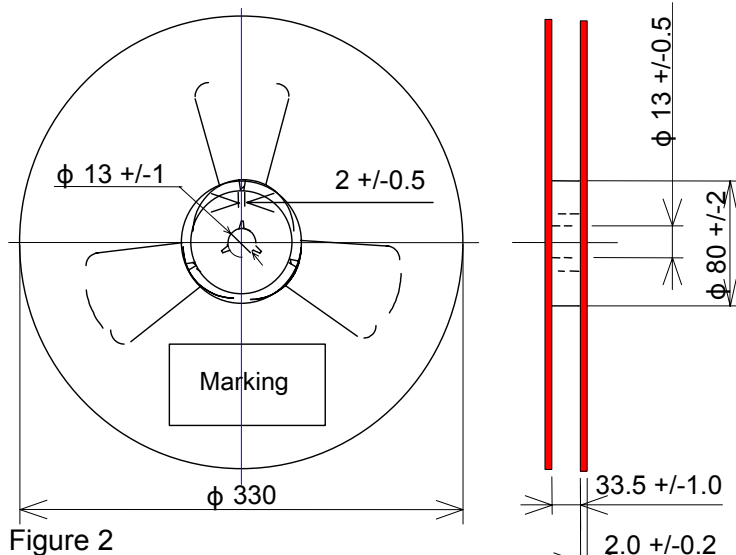

HIGH FREQUENCY PRODUCTS DIVISION
Module Business
PANASONIC ELECTRONIC DEVICES
(EUROPE) GmbH

APPROVED
genehmigt

CHECKED
geprüft

DESIGNED
erstellt

CLASSIFICATION Einstufung	PRODUCT SPECIFICATION Produktspezifikation	No. DS-ETR2-2400-102	REV. D
SUBJECT Thema	MODEM FOR IEEE802.15.4 (ZIGBEE) "ZigBee" Modem" (IEEE802.15.4)	PAGE Seite	26 of 29
CUSTOMER'S CODE ETRX2	PANASONIC'S CODE ENWC9A0xyzE	DATE Datum	01.08.2006

25. ORDERING INFORMATION

Bestellinformationen

Ordering part number	Description	MOQ ⁽¹⁾
ENWCZA05A3E ⁽²⁾	Engineering Sample ETRX2 ETRX2 with integrated ceramic antenna (U.FL socket will not be mounted, when the module is in mass production)	1
ENWCZA06N2E ⁽²⁾	Engineering Sample ETRX2 ETRX2 with U.FL male socket (ceramic antenna will not be mounted, when the module is in mass production)	1
ENWC9A07N4E ⁽²⁾	Engineering Sample ETRX2 ETRX2 with RF out on a SMD pad (U.FL plug and ceramic antenna will not be mounted, when the module is in mass production)	1

Notes:

- (1) Abbreviation for Minimum Order Quantity (MOQ). .If this module is in mass production the standard MOQ are 400 pieces, fewer only on customer demand.
- (2) As long as the module has engineering status, the ceramic antenna and the U.FL socket are mounted for all versions.
The "Z" in the ordering part number indicates the engineering sample status. After mass production the "Z" will be changed to the "9".

HIGH FREQUENCY PRODUCTS DIVISION
Module Business
PANASONIC ELECTRONIC DEVICES
(EUROPE) GmbH

APPROVED
genehmigt

CHECKED
geprüft

DESIGNED
erstellt

CLASSIFICATION Einstufung	PRODUCT SPECIFICATION Produktspezifikation	No. DS-ETR2-2400-102	REV. D
SUBJECT Thema	MODEM FOR IEEE802.15.4 (ZIGBEE) "ZigBee" Modem" (IEEE802.15.4)	PAGE Seite	27 of 29
CUSTOMER'S CODE ETRX2	PANASONIC'S CODE ENWC9A0xyzE	DATE Datum	01.08.2006

26. ROHS DECLARATION

RoHS-Erklärung

Declaration of environmental compatibility for supplied products:

Hereby we declare to our best present knowledge based on declaration of our suppliers that this product do not contain by now the following substances which are banned by Directive 2002/95/EC (RoHS) or if contain a maximum concentration of 0,1% by weight in homogeneous materials for

- Lead and lead compounds
- Mercury and mercury compounds
- Chromium (VI)
- PBB (polybrominated biphenyl) category
- PBDE (polybrominated biphenyl ether) category

And a maximum concentration of 0,01% by weight in homogeneous materials for

- Cadmium and cadmium compounds

27. DATA SHEET STATUS

Datenblatt Status

This data sheet contains data from the PRELIMINARY specification. Supplementary data will be published at a later date. Panasonic Electronic Devices (Europe) GmbH reserves the right to change the specification without notice, in order to improve the design and supply the best possible product.

Please consult the most recently issued data sheet before initiating or completing a design.

HIGH FREQUENCY PRODUCTS DIVISION
Module Business
PANASONIC ELECTRONIC DEVICES
(EUROPE) GmbH

APPROVED
genehmigt

CHECKED
geprüft

DESIGNED
erstellt

CLASSIFICATION Einstufung	PRODUCT SPECIFICATION Produktspezifikation	No. DS-ETR2-2400-102	REV. D
SUBJECT Thema	MODEM FOR IEEE802.15.4 (ZIGBEE) "ZigBee" Modem" (IEEE802.15.4)	PAGE Seite	28 of 29
CUSTOMER'S CODE ETRX2	PANASONIC'S CODE ENWC9A0xyzE	DATE Datum	01.08.2006

28. REGULATORY INFORMATION

28.1. FCC NOTICE



The device ETRX2, including the ceramic antenna (ENWC9A05A3E) complies with Part 15 of the FCC Rules. The device meets the requirements for modular transmitter approval as detailed in FCC public Notice DA00-1407.transmitter
Operation is subject to the following two conditions: (1) This device may not cause harmful interference, and (2) This device must accept any interference received, including interference that may cause undesired operation.

28.2. CAUTION



The FCC requires the user to be notified that any changes or modifications made to this device that are not expressly approved by Panasonic Electronic Devices Europe GmbH may void the user's authority to operate the equipment.

This equipment has been tested and found to comply with the limits for a Class B digital device, pursuant to Part 15 of the FCC Rules. These limits are designed to provide reasonable protection against harmful interference in a residential installation. This equipment generates, uses and can radiate radio frequency energy and, if not installed and used in accordance with the instructions, may cause harmful interference to radio communications. However, there is no guarantee that interference will not occur in a particular installation. If this equipment does cause harmful interference to radio or television reception, which can be determined by turning the equipment off and on, the user is encouraged to try to correct the interference by one or more of the following measures:

- Reorient or relocate the receiving antenna.
- Increase the separation between the equipment and receiver.
- Connect the equipment into an outlet on a circuit different from that to which the receiver is connected.
- Consult the dealer or an experienced radio/TV technician for help

28.3. LABELING REQUIREMENTS



The Original Equipment Manufacturer (OEM) must ensure that FCC labeling requirements are met. This includes a clearly visible label on the outside of the OEM enclosure specifying the appropriate Panasonic FCC identifier for this product as well as the FCC Notice above. The FCC identifier are **FCCID: T7VEM250A**. This FCC identifier is only valid for the part number ENWC9A05A3E (ETRX2 with mounted ceramic antenna). For details, please see the chapter 25. Ordering Information.

The EUT is labelled with FCC ID: T7VEM250A. This Label must be visible for the user in the end product. If the module is inside of an end product, the label will not be visible. In this case the end product will be labelled exterior with "Contains FCC ID: T7VEM250A"

HIGH FREQUENCY PRODUCTS DIVISION Module Business PANASONIC ELECTRONIC DEVICES (EUROPE) GmbH	APPROVED genehmigt	CHECKED geprüft	DESIGNED erstellt
--	-----------------------	--------------------	----------------------

CLASSIFICATION Einstufung	PRODUCT SPECIFICATION Produktspezifikation	No. DS-ETR2-2400-102	REV. D
SUBJECT Thema	MODEM FOR IEEE802.15.4 (ZIGBEE) "ZigBee" Modem" (IEEE802.15.4)	PAGE Seite	29 of 29
CUSTOMER'S CODE ETRX2	PANASONIC'S CODE ENWC9A0xyzE	DATE Datum	01.08.2006

28.4. ANTENNA WARNING



The related part number for this device is ENWC9A06N2E (ETRX2 with mounted connector). For details, please see the chapter 25. Ordering Information. This device will be tested with an UFL connector from company Hirose and with the antennas listed below. When integrated in the OEMs product, these fixed antennas require installation preventing end-users from replacing them with non-approved antennas. Any antenna not in the following table must be tested to comply with FCC Section 15.203 for unique antenna connectors and Section 15.247 for emissions. The FCC identifier for this device will be available, after a first measurement with an approved antenna.

28.5. APPROVED ANTENNA LIST

Note: We are able to qualify your antenna and will add to this list as that process is completed.

Item	Part Number	Manufacturer	Frequency Band	Type	Gain (dBi)
1					
2					

28.6. RF EXPOSURE ETRX2



To comply with FCC RF Exposure requirements, the Original Equipment Manufacturer (OEM) must ensure that the approved antenna in the previous table must be installed and/or configured to operate with a separation distance of 2.5cm or more from all persons to satisfy RF Exposure compliance.

The preceding statement must be included as a CAUTION statement in manuals for products operating with the approved antennas in the previous table to alert users on FCC RF Exposure compliance.

Any notification to the end user of installation or removal instructions about the integrated radio module is not allowed.

The radiated output power of ETRX2 with mounted ceramic antenna (FCC ID: T7VEM250A) is far below the FCC radio frequency exposure limits.

Nevertheless, the ETRX2 shall be used in such a manner that the potential for human contact during normal operation is minimized.

The EUT meets the requirements of FCC section 15.249, even if the EUT transmitted at the maximum allowed field strength (50,000 uV/m), which the equivalent e.i.r.p would be 0.75 mW. End users may not be provided with the module installation instructions. OEM integrators and end users must be provided with transmitter operating conditions for satisfying RF exposure compliance.

HIGH FREQUENCY PRODUCTS DIVISION Module Business PANASONIC ELECTRONIC DEVICES (EUROPE) GmbH	APPROVED genehmigt	CHECKED geprüft	DESIGNED erstellt
--	-----------------------	--------------------	----------------------

CLASSIFICATION Einstufung	PRODUCT SPECIFICATION Produktspezifikation	No. DS-ETR2-2400-102	REV. D
SUBJECT Thema	MODEM FOR IEEE802.15.4 (ZIGBEE) "ZigBee" Modem" (IEEE802.15.4)	PAGE Seite	30 of 29
CUSTOMER'S CODE ETRX2	PANASONIC'S CODE ENWC9A0xyzE	DATE Datum	01.08.2006

29. RELATED DOCUMENTS

Mitgeltende Dokumente

- [1] IEEE Standard 802.15.4 –2003 Wireless Medium Access Control (MAC) and Physical Layer (PHY) Specifications for Low-Rate Wireless Personal Area Networks (LR-WPANs)
- [2] Data Sheet EM250, 120-0082-000F March 23, 2006, Ember Inc. (www.ember.com)
- [3] Data Sheet U.FL-Series 2004.2 Hirose
Ultra Small Surface Mount Coaxial Connectors - Low Profile 1.9mm or 2.4mm Mated Height

HIGH FREQUENCY PRODUCTS DIVISION
Module Business
PANASONIC ELECTRONIC DEVICES
(EUROPE) GmbH

APPROVED
genehmigt

CHECKED
geprüft

DESIGNED
erstellt

CLASSIFICATION Einstufung	PRODUCT SPECIFICATION Produktspezifikation	No. DS-ETR2-2400-102	REV. D
SUBJECT Thema	MODEM FOR IEEE802.15.4 (ZIGBEE) "ZigBee" Modem" (IEEE802.15.4)	PAGE Seite	31 of 29
CUSTOMER'S CODE ETRX2	PANASONIC'S CODE ENWC9A0xyzE	DATE Datum	01.08.2006

30. GENERAL INFORMATION

Allgemeine Informationen

© Panasonic Electronic Devices (Europe) GmbH 2006.

All rights reserved.

This product description does not lodge the claim to be complete and free of mistakes.

Please contact the related product manager in every case.

If we deliver samples to the customer, these samples have the status Engineering Samples. This means, the design of this product is not yet concluded. Engineering Samples may be partially or fully functional, and there may be differences to be published Data Sheet.

Engineering Samples are not qualified and are not to be used for reliability testing or series production.

Disclaimer:

Customer acknowledges that samples may deviate from the Data Sheet and may bear defects due to their status of development and the lack of qualification mentioned above.

Panasonic Electronic Devices (Europe) GmbH rejects any liability or product warranty for Engineering Samples. In particular, Panasonic Electronic Devices (Europe) GmbH disclaims liability for damages caused by

- the use of the Engineering Sample other than for Evaluation Purposes, particularly the installation or integration in an other product to be sold by Customer,
- deviation or lapse in function of Engineering Sample,
- improper use of Engineering Samples.

Panasonic Electronic Devices (Europe) GmbH disclaims any liability for consequential and incidental damages.

In case of any questions, please contact your local sales partner or the related product manager.

31. LIFE SUPPORT POLICY

Politik für Lebenserhaltungssysteme

This Panasonic Electronic Devices (Europe) GmbH product is not designed for use in life support appliances, devices, or systems where malfunction can reasonably be expected to result in a significant personal injury to the user, or as a critical component in any life support device or system whose failure to perform can be reasonably expected to cause the failure of the life support device or system, or to affect its safety or effectiveness. Customers using or selling these products for use in such applications do so at their own risk and agree to fully indemnify Panasonic Electronic Devices (Europe) GmbH for any damages resulting.

HIGH FREQUENCY PRODUCTS DIVISION Module Business PANASONIC ELECTRONIC DEVICES (EUROPE) GmbH	APPROVED genehmigt	CHECKED geprüft	DESIGNED erstellt
--	-----------------------	--------------------	----------------------