

PAN9019 / PAN9019A

Wi-Fi 6 Dual Band 2.4 GHz/5 GHz, Bluetooth® and
802.15.4 (PAN9019A only) Module

Module Integration Guide

Rev. 1.0

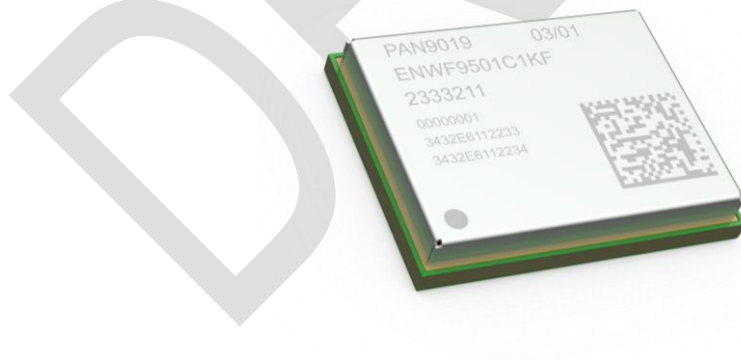

Overview

The PAN9019 and PAN9019A are 2.4 GHz and 5 GHz ISM band Wi-Fi, Bluetooth, and 802.15.4¹ radio modules, which allow easy integration of Wi-Fi, Bluetooth, and 802.15.4¹ based technologies into various electronic devices.

Features

- Dual band 2.4 GHz and 5 GHz 802.11 a/b/g/n/ac/ax Wi-Fi, Bluetooth, and 802.15.4¹ combo module
- Supports WPA3 security
- Secured boot and firmware
- 802.11e Quality of Service is supported for multimedia application
- IEEE 802.11ax, 1x1 spatial stream with data rates up to 600 Mbps (MCS11, 80 MHz channel bandwidth)
- OFDMA (UL/DL) and MU-MIMO (UL/DL)
- Bluetooth 5.4 (including LE and long range)
- WCI-2- and 5-wire PTA coexistence interfaces
- Generic interfaces include SDIO 3.0, high-speed UART and SPI² for host processor connection
- OS driver support for RTOS, Linux®, and Android™

Characteristics

- Surface Mount Type (SMT):
15.3 mm x 12 mm x 2.5 mm
- PAN9019: NXP® IW611 WLAN 2.4 GHz and 5 GHz, Bluetooth single-chip solution inside
- PAN9019A: NXP IW612 WLAN 2.4 GHz and 5 GHz, Bluetooth and 802.15.4 single-chip solution inside
- Rx sensitivity: -98 dBm at IEEE 802.11b 1 Mbps
- IEEE 802.11ax 20 MHz, 40 MHz, 80 MHz channel bandwidth
- Power supply: 1.8 V and 3.3 V
- SDIO 1 bit or 4 bit
- Wide temperature range: -40 °C to 85 °C

Block Diagram

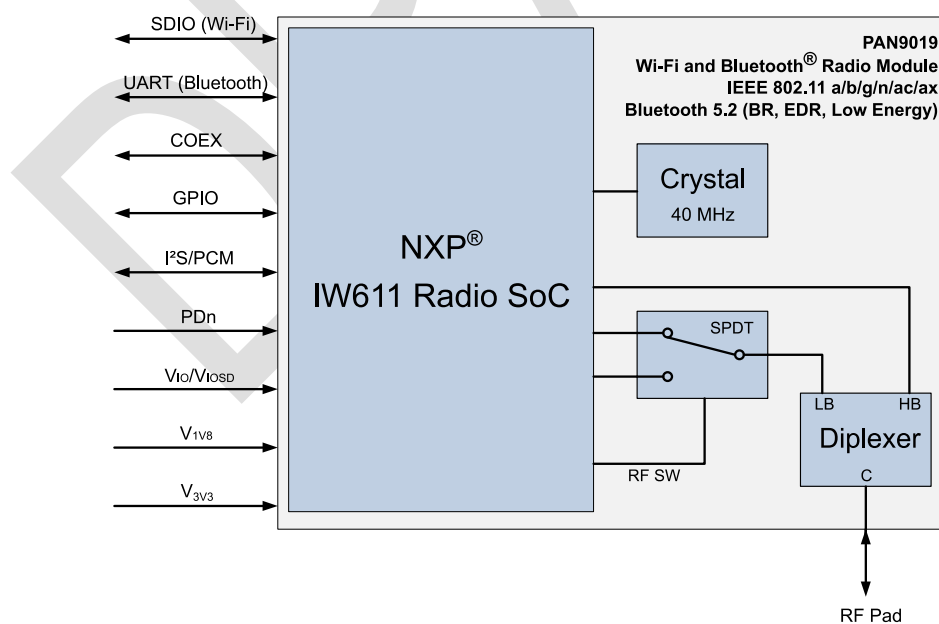

¹ 802.15.4 is only supported by the PAN9019A module.

² SPI is available as 802.15.4 host interface (only on PAN9019A module).

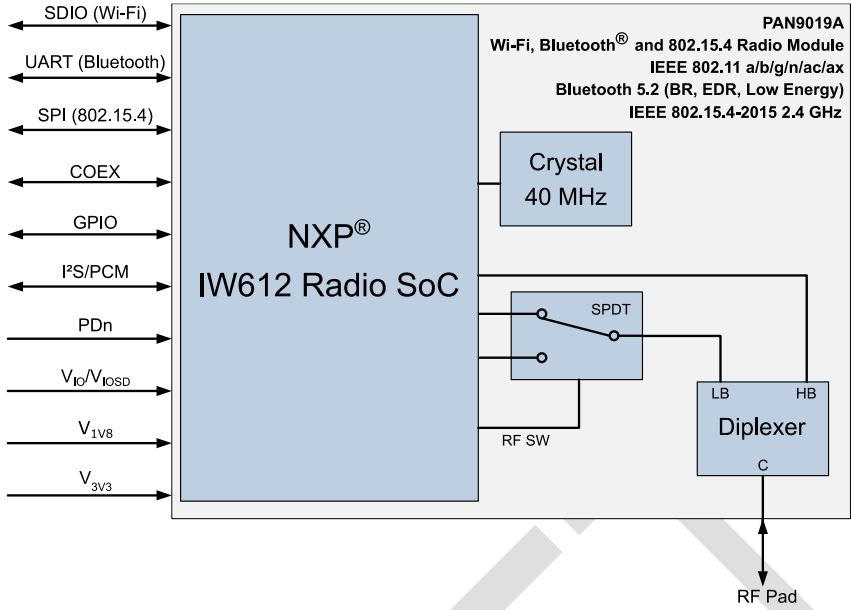

DRAFT

By purchase of any of the products described in this document the customer accepts the document's validity and declares their agreement and understanding of its contents and recommendations. Panasonic Industrial Devices Europe GmbH (Panasonic) reserves the right to make changes as required at any time without notification. Please consult the most recently issued Module Integration Guide before initiating or completing a design.

© Panasonic Industrial Devices Europe GmbH 2024.

This specification sheet is copyrighted. Reproduction of this document is permissible only if reproduction is without alteration and is accompanied by all associated warranties, conditions, limitations, and notices. Do not disclose it to a third party.

All rights reserved.

This Module Integration Guide does not lodge the claim to be complete and free of mistakes.

If this document is marked as preliminary, please be aware that its final content is not yet concluded and the use of it is at your own risk.

Engineering Samples (ES)

If Engineering Samples are delivered to the customer, these samples have the status "Engineering Samples". This means that the design of this product is not yet concluded. Engineering Samples may be partially or fully functional, and they may differ from the published Product Specification.

Engineering Samples are not qualified and they are not to be used for reliability testing or series production.

Disclaimer

The customer acknowledges that samples may deviate from the Module Integration Guide and may bear defects due to their status of development and the lack of qualification mentioned above.

Panasonic rejects any liability or product warranty for Engineering Samples. In particular, Panasonic disclaims liability for damages caused by:

- The use of the Engineering Sample other than for evaluation purposes, particularly the installation or integration in another product to be sold by the customer,
- Deviation or lapse in function of the Engineering Sample,
- Improper use of the Engineering Sample.

Panasonic Industrial Devices Europe GmbH disclaims any liability for consequential and incidental damages. In case of any queries regarding the Engineering Samples, please contact your local sales partner or the related product manager.

The information contained herein is presented only as guidance for Product use. No responsibility is assumed by Panasonic for any infringement of patents or any other intellectual property rights of third parties that may result from the use of Product. No license to any intellectual property right is granted by this document, whether express or implied, by estoppel or otherwise.

Description of hardware, software, and other information in this document is only intended to illustrate the functionality of the referred Panasonic product. It should not be construed as guaranteeing specific functionality of the product as described or suitable for a particular application.

Any provided (source) code shall not be used or incorporated into any products or systems whose manufacture, use or sale is prohibited under any applicable laws or regulations.

Any outlined or referenced (source) code within this document is provided on an "as is" basis without any right to technical support or updates and without warranty of any kind on a free of charge basis according to § 516 German Civil Law (BGB) including without limitation, any warranties or conditions of title, non infringement, merchantability, or fitness for a particular purpose. Customer acknowledges that (source) code may bear defects and errors.

The third-party tools mentioned in this document are offered by independent third-party providers who are solely responsible for these products. Panasonic has no responsibility whatsoever for the performance, product descriptions, specifications, referenced content, or any and all claims or representations of these third-party providers. Panasonic makes no warranty whatsoever, neither express nor implied, with respect to the goods, the referenced contents, or any and all claims or representations of the third-party providers.

To the maximum extent allowable by Law Panasonic assumes no liability whatsoever including without limitation, indirect, consequential, special, or incidental damages or loss, including without limitation loss of profits, loss of opportunities, business interruption, and loss of data.

DRAFT

Table of Contents

1	About This Document	7
1.1	Purpose and Audience	7
1.2	Revision History.....	7
1.3	Use of Symbols	7
1.4	Related Documents	8
2	Overview	9
3	PAN9019 / PAN9019A Module	10
3.1	Block Diagram	10
3.2	Land Pattern	11
3.3	Footprint	12
3.4	Solder Resist Mask and Solder Paste Stencil.....	13
4	Power Supply	14
4.1	General Guidance	14
4.2	Power Supply Terminals.....	14
5	RF Interface	16
5.1	RF Trace.....	16
5.2	Antennas	17
6	Host Interfaces	26
6.1	SDIO Interface.....	26
6.2	UART Interface.....	26
6.3	SPI Interface.....	28
7	M.2 Reference Design	29
7.1	Reference Schematics.....	29
7.2	Reference Layout	32
8	Software Integration	35
8.1	Wi-Fi – Regulatory Compliant Bring Up	35
8.2	Bluetooth – Regulatory Compliant Bring Up	43
8.3	802.15.4 – Regulatory Compliant Bring Up	50
9	Contact Details	52
9.1	Contact Us.....	52
9.2	Product Information	52

1 About This Document

1.1 Purpose and Audience

This Module Integration Guide is intended to support the easy integration of the PAN9019 and PAN9019A into a product and to ensure the compliance with regulatory requirements.

This guide gives an overview about the hardware design requirements by providing a reference design, which is the evaluation board of the PAN9019 and PAN9019A.



It is intended for hardware design, application, and Original Equipment Manufacturers (OEM) engineers.

The product is referred to as “PAN9019 / PAN9019A” and “module” within this document.

1.2 Revision History

Revision	Date	Modifications/Remarks
0.1	2023-08-04	First preliminary version
0.2	2023-11-22	Added antenna lists in ⇒ 5.2 Antennas Added subsections in ⇒ 5.2.2 External Antennas Added section ⇒ 5.2.1.3 Design Verification Changed reference matching and tuning components in ⇒ 5.2.1.2 Antenna Layout Updated pictures in ⇒ 5.2.1.2 Antenna Layout
1.0	2024-03-08	Added ⇒ 8 Software Integration Corrected direction of SPI_FRM in ⇒ 6.3 SPI Interface

1.3 Use of Symbols

Symbol	Description
	Note Indicates important information for the proper use of the product. Non-observance can lead to errors.
	Attention Indicates important notes that, if not observed, can put the product’s functionality at risk.
	Tip Indicates useful information designed to facilitate working with the software.
⇒ [chapter number] [chapter title]	Cross reference Indicates cross references within the document. Example: Description of the symbols used in this document ⇒ 1.3 Use of Symbols .

Symbol	Description
✓	<p>Requirement</p> <p>Indicates a requirement that must be met before the corresponding tasks can be completed.</p>
→	<p>Result</p> <p>Indicates the result of a task or the result of a series of tasks.</p>
This font	<p>GUI text</p> <p>Indicates fixed terms and text of the graphical user interface.</p> <p>Example:</p> <p>Click Save.</p>
Menu > Menu item	<p>Path</p> <p>Indicates a path, e.g. to access a dialog.</p> <p>Example:</p> <p>In the menu, select File > Setup page.</p>
This font	<p>File names</p> <p>Indicates file names displayed on the screen or to be selected by the user.</p> <p>Examples:</p> <p>pan1760.c contains the actual module initialization.</p>
This font	<p>Messages, user input, code</p> <p>Indicates messages, information, and code displayed on the screen or to be entered by the user.</p> <p>Examples:</p> <p>The message Failed to save your data is displayed.</p> <p>Enter the value Product 123.</p> <p>Copy firmware binaries to firmware library:</p> <pre>\$> cd \${TOP}/... \$> ...</pre>
Key	<p>Key</p> <p>Indicates a key on the keyboard.</p> <p>Example:</p> <p>Press F10.</p>

1.4 Related Documents

For related documents please refer to the Panasonic website ⇒ [9.2 Product Information](#).

2 Overview

The PAN9019 / PAN9019A is a dual band 2.4 GHz and 5 GHz 802.11 a/b/g/n/ac/ax Wi-Fi radio module with integrated Bluetooth BR/EDR/Low Energy (LE) and 802.15.4³ radio, specifically designed for highly integrated and cost-effective applications. The independent operation of the three standards enables 802.11ax data rates with high efficiency (HE) and low-power operation (Bluetooth LE and 802.15.4³).

Latest technologies like multiuser MIMO and OFDMA improve the efficiency in large networks, while the 1024-QAM modulation allows high data rates. Integrated power management, a fast dual-core CPU, 802.11i/w security standard support, and high-speed data interfaces deliver the performance for the speed, reliability, and quality requirements of next generation products.

Tx power calibration data and Wi-Fi/Bluetooth/802.15.4³ system parameters are pre-stored on the one-time-programmable memory of the PAN9019 / PAN9019A during production at Panasonic. Thus, the module reduces design, test, and calibration effort resulting in reduced time-to-market compared to discrete solutions.

Integrating Wi-Fi, Bluetooth, and 802.15.4³ wireless connectivity allows high throughput applications for industrial devices and appliances. The combination of Wi-Fi, Bluetooth, and 802.15.4³ provides the highest flexibility for connectivity. This Module Integration Guide applies to the PAN9019 / PAN9019A WLAN and Bluetooth combo module and the PAN9019 / PAN9019A M.2 evaluation platforms.

For related documents please refer to [⇒ 9.2 Product Information](#).

DRAFT

³ 802.15.4 is only supported by the PAN9019A module.

3 PAN9019 / PAN9019A Module

3.1 Block Diagram

For PAN9019 (ENWF9501C1KF)

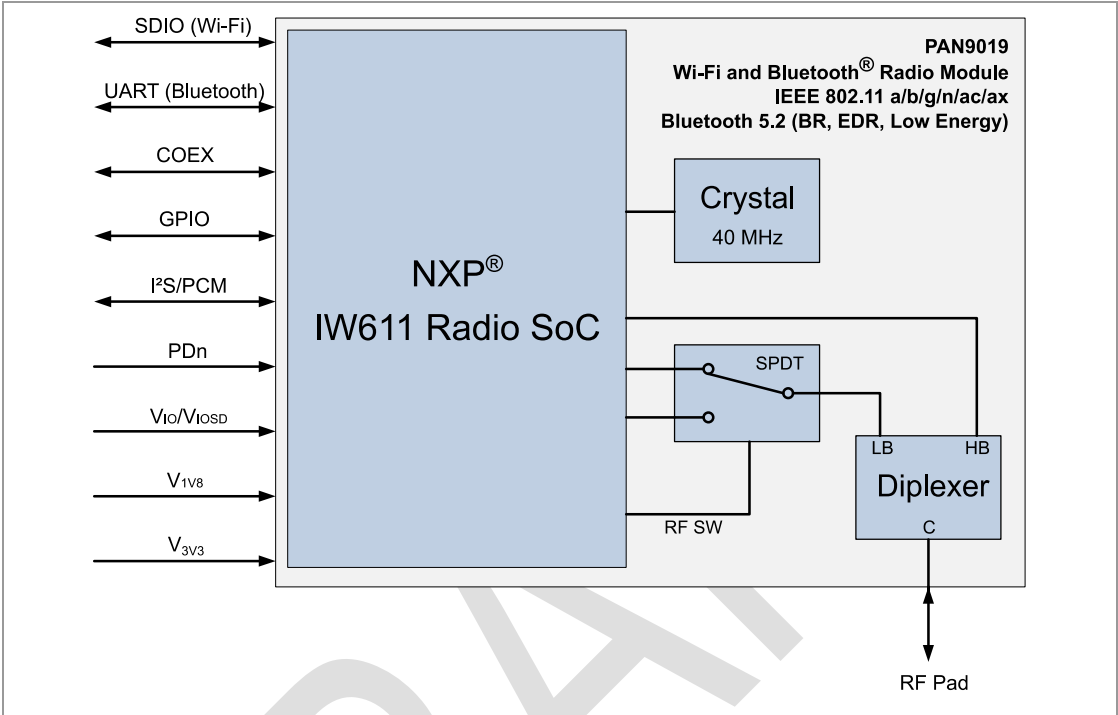

For PAN9019A (ENWF9511C1KF)

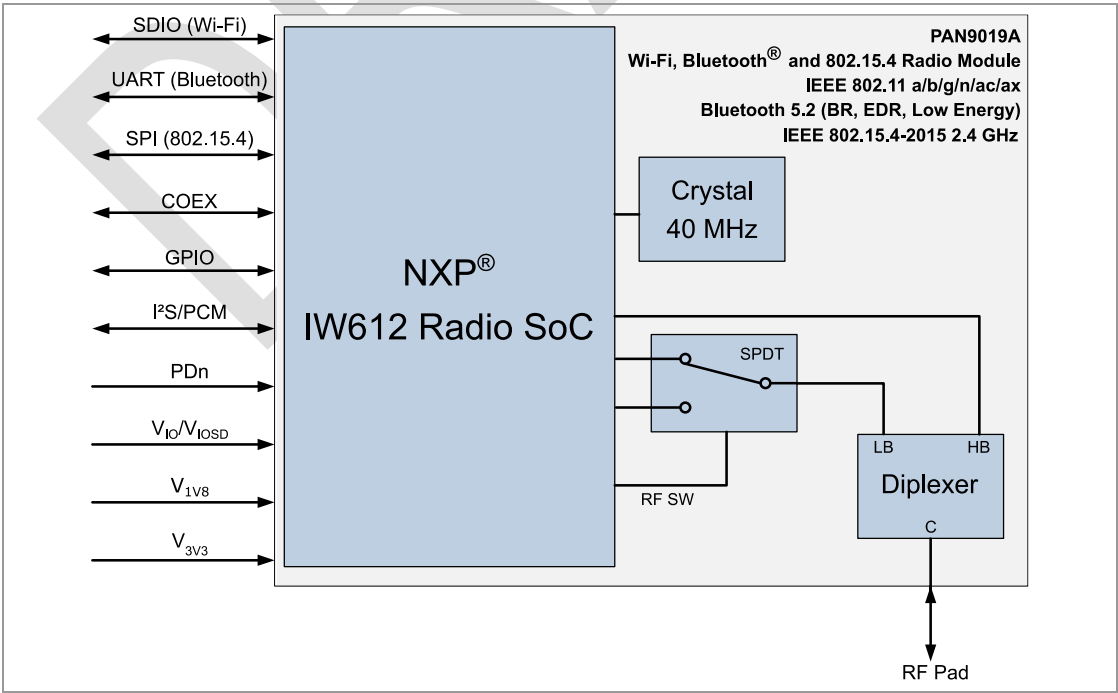

3.2 Land Pattern

Top View

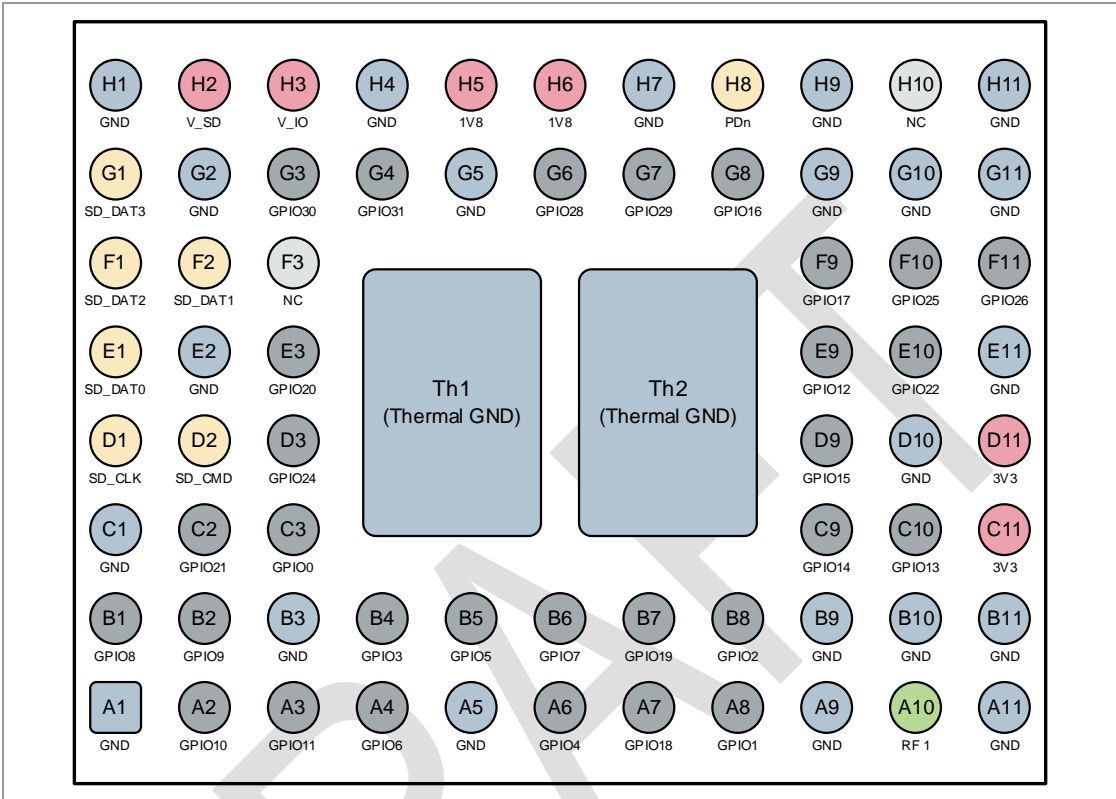

3.3 Footprint

 All dimensions are in millimeters.
The outer dimensions have a tolerance of ± 0.35 mm.

Top View

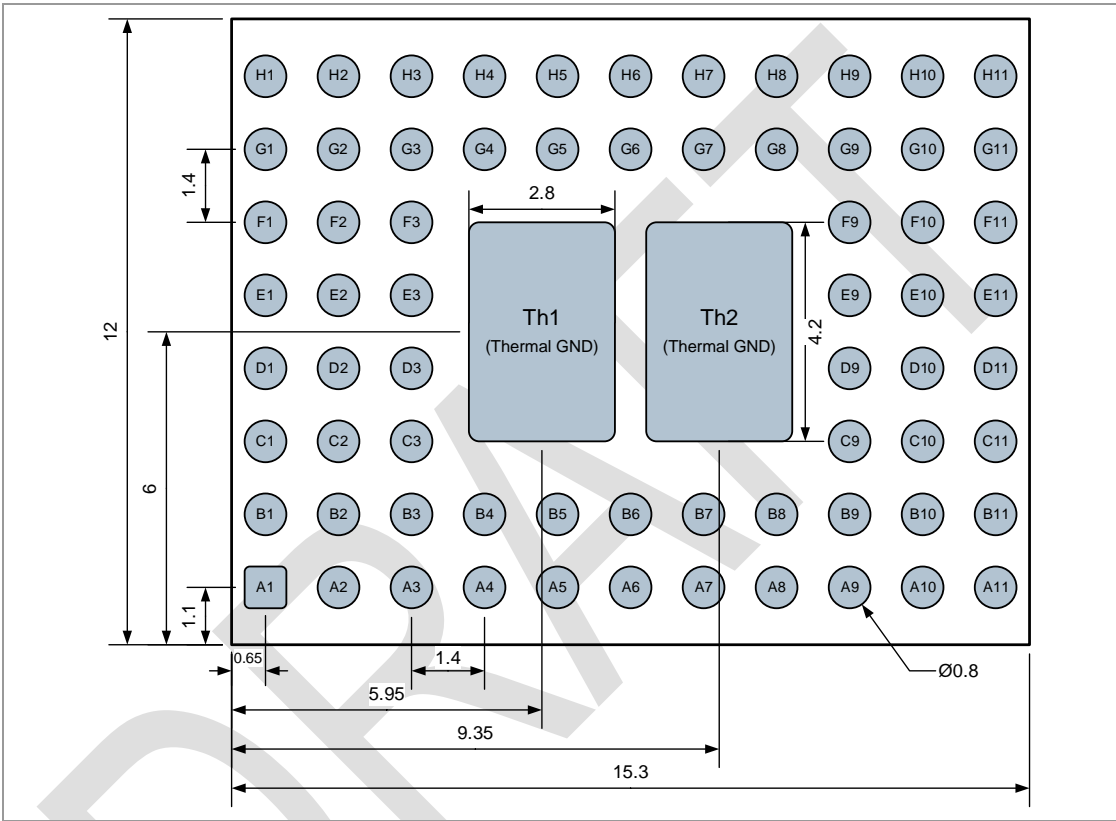

3.4 Solder Resist Mask and Solder Paste Stencil

It is recommended to use the following layout for the solder resist mask and the solder paste stencil to reduce voids on the pads.

The following dimensions are recommended:

- ✓ The solder resist mask should be 50 µm bigger (circumferential) than the pad size (non-solder-mask-defined design).
- ✓ The solder paste stencil apertures should have the same size as the copper pads; they are separated in two semi circles with 300 µm distance and are shifted about 150 µm towards the outside.



For details on the dimensions of the copper pads please refer to
⇒ 3.3 Footprint.

Solder Paste Stencil Layout

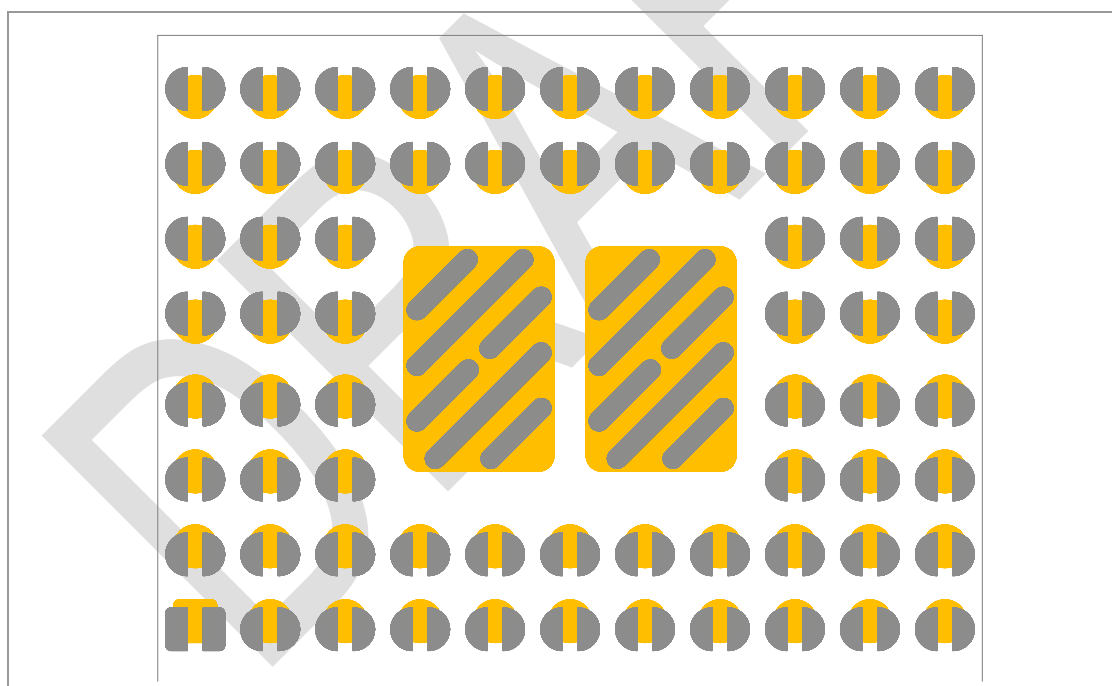

4 Power Supply

4.1 General Guidance

The following requirements must be met:

- ✓ The supply voltage must be free of AC ripple voltage (for example from a battery or a low noise regulator output). For noisy supply voltages, provide a decoupling circuit (for example a ferrite in series connection and a bypass capacitor to ground of at least 47 μF directly at the module).
- ✓ The supply voltage must not be exceedingly high or reversed. It must not carry noise and spikes.

4.2 Power Supply Terminals

The PAN9019 / PAN9019A requires 1.8 V and 3.3 V supply voltages for operation. All supply pins are marked and enumerated in the figure below. All power signals are described in the subsequent table.

Top View

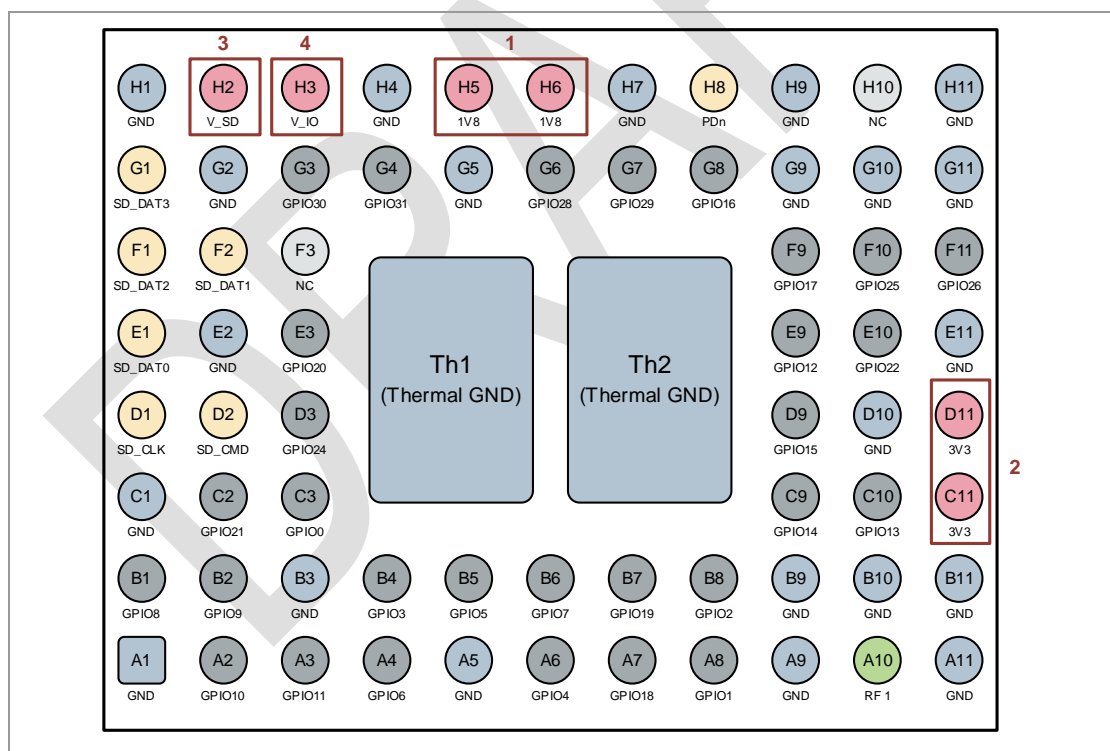

Enumeration	Name	Nominal Voltage	Description
1	1V8	1.8 V	Main power supply The supply source should be capable to drive at least 1 A.
2	3V3	3.3 V	Supply for Wi-Fi PA and internal RF control pins The supply source could be capable to drive at least 500 mA.
3	V_SD	1.8 V or 3.3 V	Supply voltage for the digital SDIO interface
4	V_IO	1.8 V or 3.3 V	Supply voltage for all other digital IO interfaces

DRAFT

5 RF Interface

The PAN9019 / PAN9019A modules can be used in combination with various antennas that are listed in this document. The design rules given in this document must be followed to meet the regulatory requirements.

5.1 RF Trace

A 50 Ω trace shall be used for connecting the module either to the documented chip antenna or to a MHF4(L) connector for external antenna usage.

This section describes the required design of the trace.

50 Ω Coplanar Waveguide Design

The following requirements must be met:

- ✓ Trace impedance of 50 Ω
- ✓ Via fence around the trace
- ✓ Coplanar waveguide design
- ✓ Substrate Material: FR4
- ✓ Height (H) of dielectric: typ. 250 $\mu\text{m} \pm 10 \mu\text{m}$
- ✓ Trace Width (W): typ. 450 $\mu\text{m} \pm 10 \mu\text{m}$
- ✓ Copper Gap (G): typ. 500 μm , min. 450 μm
- ✓ All inner layers must have the same copper-obstruct pattern as the GND on the top layer.
- ✓ The minimum trace length in [⇒ 5.2.1 Chip Antenna](#) must be regarded.

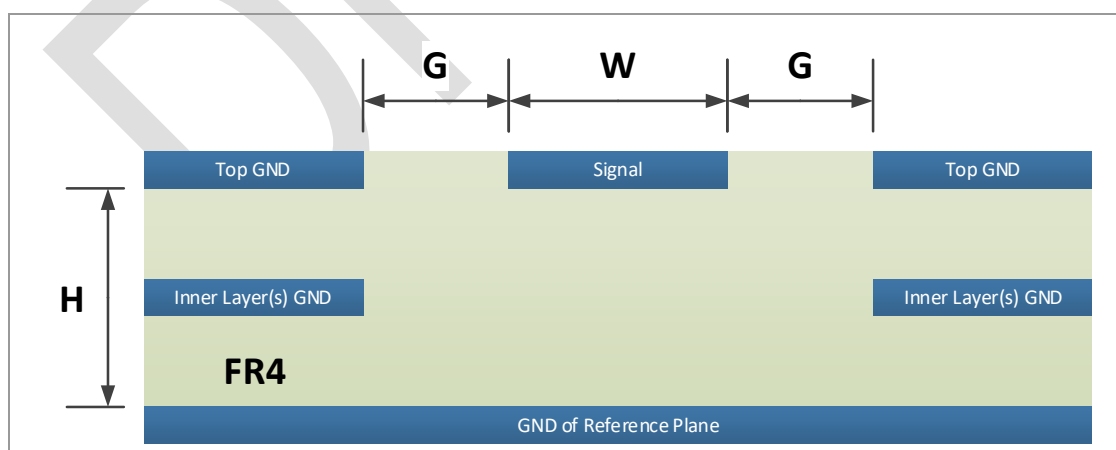

5.2 Antennas

The PAN9019 / PAN9019A modules are certified in combination with the following antenna types:

- chip antenna,
- external flex PCB antenna
- external terminal antenna

All approved antennas are listed in the corresponding subsection.

5.2.1 Chip Antenna

One option of the RF interface is to use the chip antenna ANT162442DT-2001A2 directly on the carrier PCB.

Part Number	Vendor	Type	Max. Gain (2.4 GHz band)	Max. Gain (5 GHz band)	Cable Variants
ANT162442DT-2001A2	TDK	Chip Antenna	2.1 dBi	2.3 dBi	50 Ohm trace <ul style="list-style-type: none"> • Min. length: 15 mm • Design follows ⇒ 5.2.1.1 RF Path



To comply with the regulatory requirements, all instructions of this section must be followed.

5.2.1.1 RF Path

Please follow the design described in [⇒ 5.2.1.1 RF Path](#) for connecting the antenna. The trace length should be at minimum 15 mm.

The following figure illustrates the connection on the reference design.

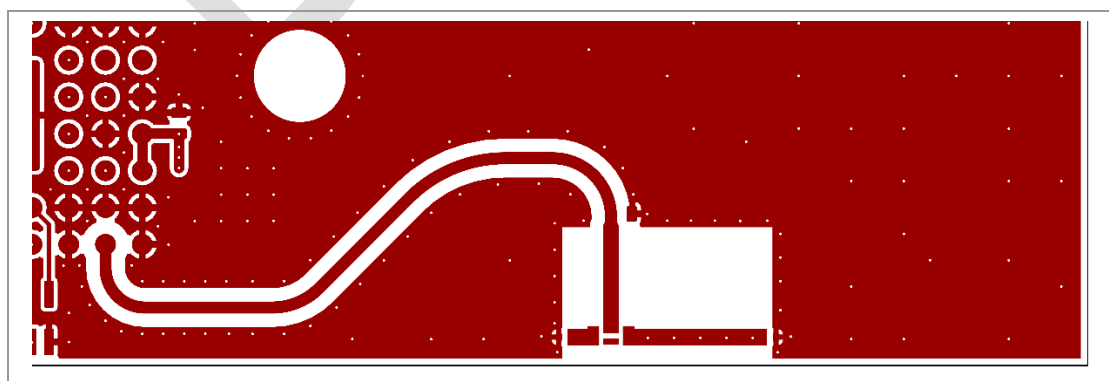

5.2.1.2 Antenna Layout

 Please note that the stackup must follow the design instructions described in ⇒ 5.2.1.1 RF Path!

This section describes the layout on the module’s carrier PCB that must be followed. A reference DXF file can be obtained from Panasonic.

The following requirements must be met:

- ✓ On the top copper layer following dimensions must be kept:

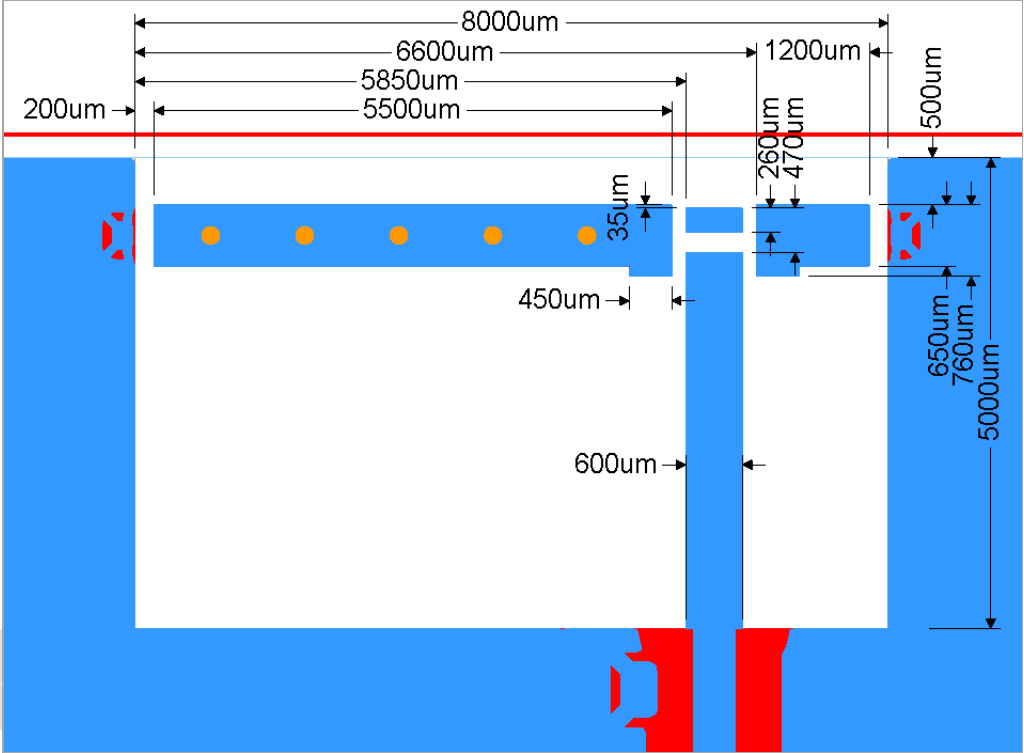

- ✓ On the lower layer, a metal structure as shown in the figure below must be placed. The shape is connected to the top layer with vias at the marked positions.

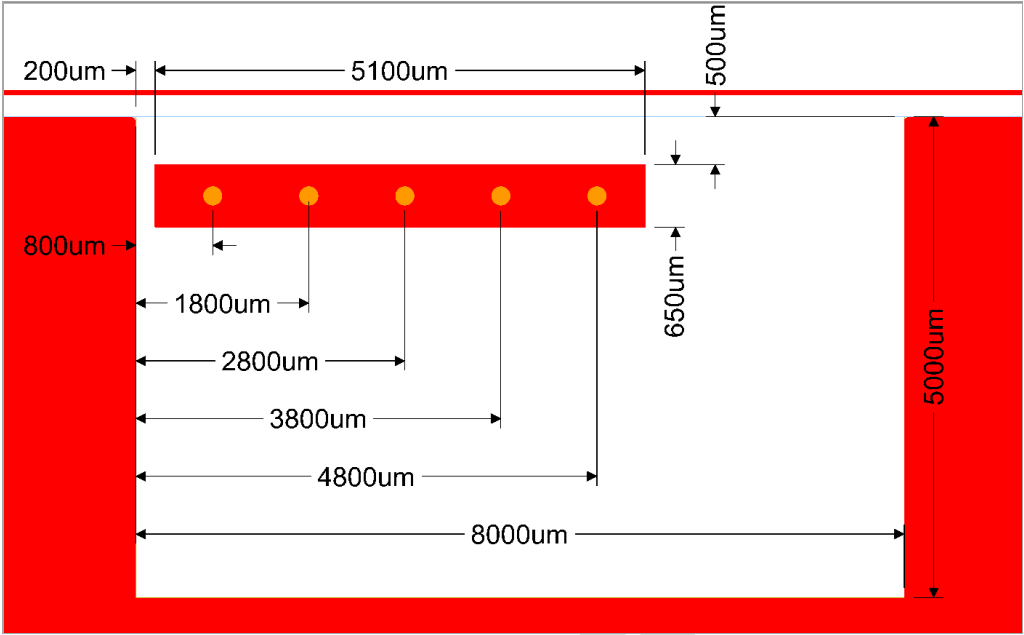

- ✓ Besides the metal structures shown in the pictures above, there must be no other metal objects within the antenna area of 8 mm × 5 mm.
- ✓ To obtain a good performance of the antenna, keep GND areas of at least 12 mm length next to the antenna “Keep out Area” on top and bottom side of the PCB. The GND areas should have a minimum depth of 20 mm towards the inside of the PCB. The dimensions are illustrated here:

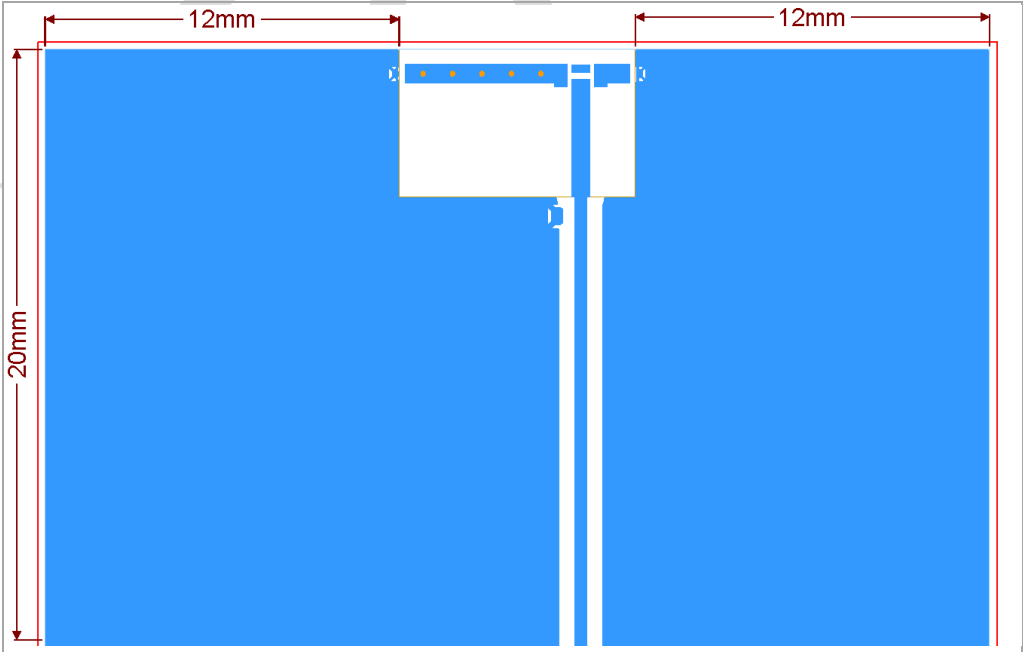

Three components are used for impedance matching and tuning of the antenna. Following table shows the reference design's component specifications.

Component	Size (inch)	Type	Value	Characteristics	Part No
Ft 2.4 GHz	0201	Capacitor	3.9 pF	± 0.1 pF, C0G	GJM0335C1E3R9BB01D
Ft 5 GHz	0201	Capacitor	0.6 pF	± 0.1 pF, C0G	GJM0335C1ER60BB01D
Mt	0402	Inductor	1 nH	± 0.1 nH, $f_r \geq 10$ GHz	LQG15HS1N0B02D

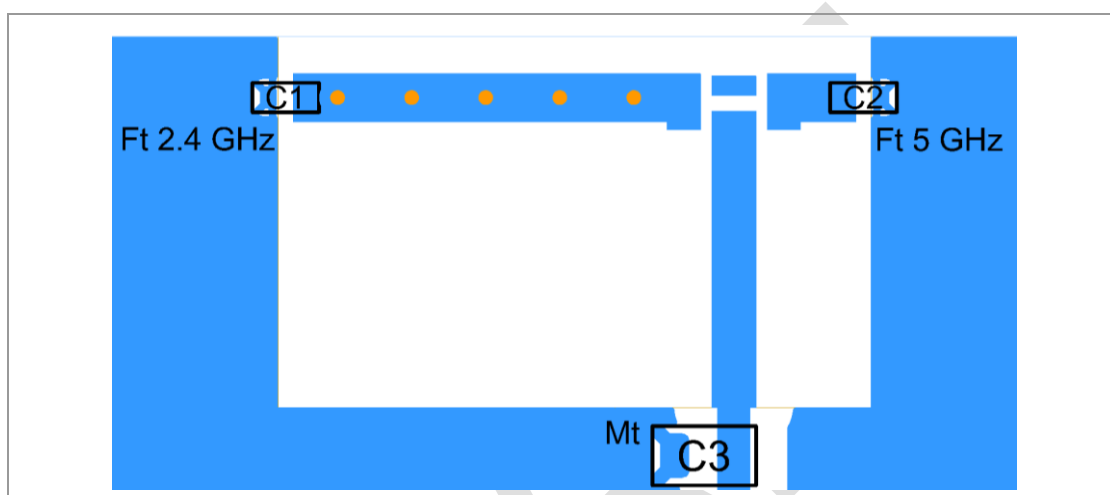

5.2.1.3 Design Verification

It shall be verified that the antenna is tuned and matched correctly. This can be done by measuring the return loss at the RF entry point on the mother PCB. Therefore, please connect a 50 Ohm probe to the RF1 landing pad and GND (e.g. a semi-rigid cable can be soldered onto the footprint's pads). The picture below illustrates the probe connection on the reference design.

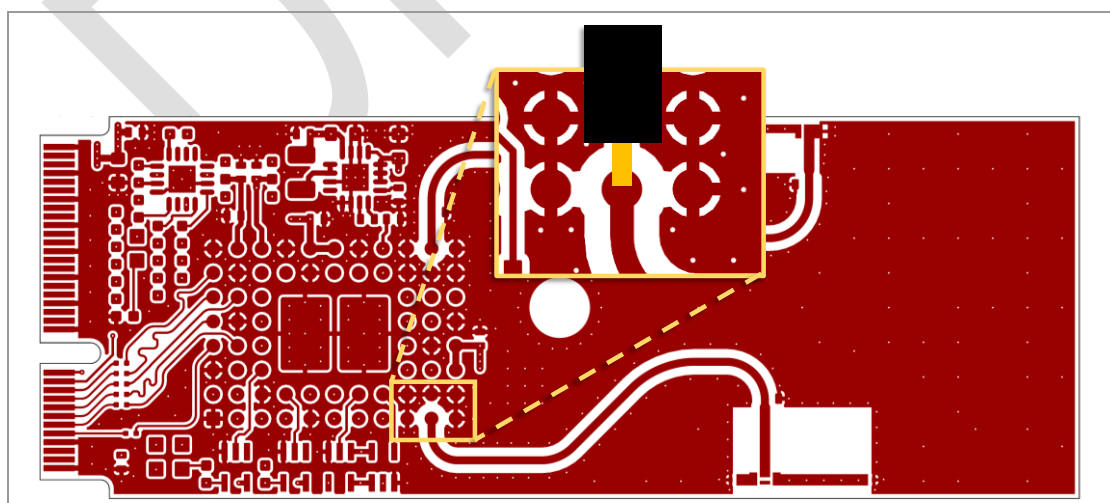

The measured return loss should look similar as in the picture below. This ensures that the antenna's tuning is good and thus the antenna radiates in the correct bands. Moreover, the effective impedance is close to 50 Ohm and the reflection towards the module is low, which is a precondition for the Tx power amplifier and Rx low noise amplifier to work as specified.

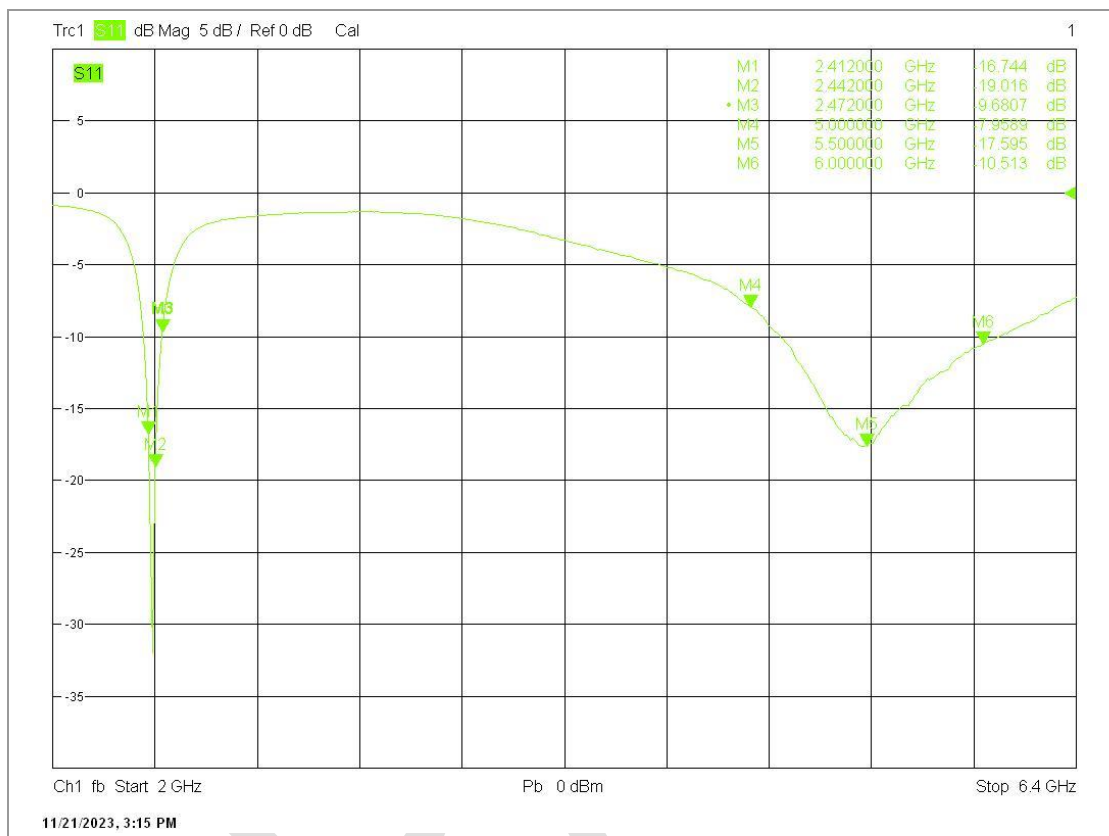

5.2.2 External Antennas



Antenna Warning

The PAN9019 / PAN9019A is tested with a standard MHF4(L) connector and with the antennas listed in the "PAN9019 / PAN9019A Product Specification". When integrated into the OEM's product, these fixed antennas require installation preventing end users from replacing them with non-approved antennas.

Any antenna not listed in the "PAN9019 / PAN9019A Product Specification" must be tested to comply with FCC section 15.203 for unique antenna connectors and with section 15.247 for emissions.

5.2.2.1 RF Path

All external antennas listed in this document require an MHF4(L) connector on the mother PCB. Please follow the design described in ⇒ [5.2.1.1 RF Path](#) for routing the module's RF signal to the MHF4(L) receptacle connector. Following picture shows the M.2 reference design.

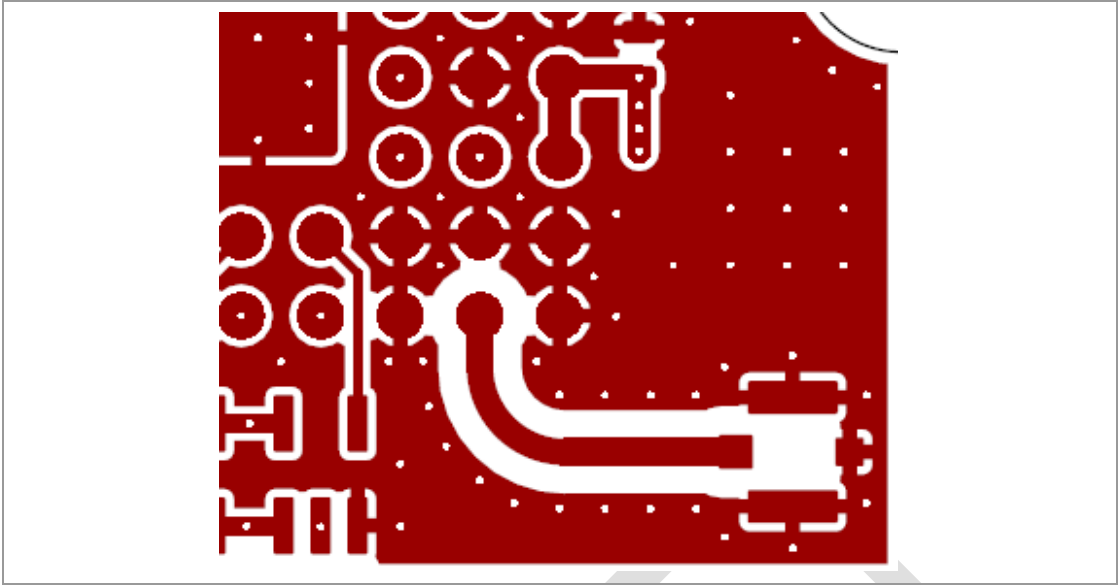

DRAFT

5.2.2.2 PCB Antennas

Part Number	Vendor	Type	Max. Gain (2.4 GHz band)	Max. Gain (5 GHz band)	Cable Options ⁴
2JF1002P	2J	Flex PCB	4.2 dBi	8.0 dBi	-005MC137-MHF4L (50 mm) -010MC137-MHF4L (100 mm) -015MC137-MHF4L (150 mm) -020MC137-MHF4L (200 mm) -025MC137-MHF4L (250 mm) -030MC137-MHF4L (300 mm)
2JF0102P	2J	Flex PCB	2.2 dBi	3.8 dBi	-005MC137-MHF4L (50 mm) -010MC137-MHF4L (100 mm) -015MC137-MHF4L (150 mm) -020MC137-MHF4L (200 mm) -025MC137-MHF4L (250 mm) -030MC137-MHF4L (300 mm)
FXP830	Taoglas	Flex PCB	2.5 dBi	4.7 dBi	.54.0055C (55 mm) .54.0100C (100 mm) .54.0150C (150 mm) .54.0200C (200 mm)
W3P35X8W04	Kyocera AVX	PCB	2.3 dBi	5 dBi	-H050D3B0A (50 mm) -H100D3B0A (100 mm) -H150D3B0A (150 mm)
W3F35X8W01	Kyocera AVX	Flex PCB	2.3 dBi	5 dBi	-H050D3B0C (50 mm) -H100D3B0C (100 mm) -H150D3B0C (150 mm)
1001932PT	Kyocera AVX	Flex PCB	2.0 dBi	4.5 dBi	-AC10L0050 (50 mm) -AC10L0100 (100 mm)

⁴ Cable option with MHF4L connector; Product number: [Part Number][Cable Option]

5.2.2.3 Terminal Mount Antennas

Part Number	Vendor	Type	Max. Gain (2.4 GHz band)	Max. Gain (5 GHz band)	Cables ⁵
GW.51.5153	Taoglas	Terminal Mount	5.2 dBi	5.5 dBi	CAB.S140 (50 mm) CAB.S119 (100 mm) CAB.S141 (150 mm) CAB.S142 (200 mm) CAB.S143 (300 mm)
2JW1102-C943B	2J	Terminal Mount	4.1 dBi	3.9 dBi	C213GST-005MC137-MHF4L (50 mm) C213GST-010MC137-MHF4L (100 mm) C213GST-015MC137-MHF4L (150 mm) C213GST-020MC137-MHF4L (200 mm) C213GST-025MC137-MHF4L (250 mm) C213GST-030MC137-MHF4L (300 mm)
X9000294-W3DRMB	Kyocera AVX	Terminal Mount	3.2 dBi	4.5 dBi	ACM13-04LB030SAR00 (30 mm) ACM13-04LB050SAR00 (50 mm) ACM13-04LB100SAR00 (100 mm) ACM13-04LB150SAR00 (150 mm) ACM13-04LB200SAR00 (200 mm) ACM13-04LB300SAR00 (300 mm)
X9001748-W3DRMB	Kyocera AVX	Terminal Mount	3.2 dBi	3.6 dBi	ACM13-04LB030SAR00 (30 mm) ACM13-04LB050SAR00 (50 mm) ACM13-04LB100SAR00 (100 mm) ACM13-04LB150SAR00 (150 mm) ACM13-04LB200SAR00 (200 mm) ACM13-04LB300SAR00 (300 mm)
X9003019-W3DRMB (Black) X9003019-W3DRMW (White)	Kyocera AVX	Terminal Mount	2.8 dBi	4.9 dBi	ACM13-04LB030SAR00 (30 mm) ACM13-04LB050SAR00 (50 mm) ACM13-04LB100SAR00 (100 mm) ACM13-04LB150SAR00 (150 mm) ACM13-04LB200SAR00 (200 mm) ACM13-04LB300SAR00 (300 mm)

DRAFT

⁵ MHF4L to RP-SMA (female) cable

6 Host Interfaces

This section describes the interfaces to the host processor. These are:

- SDIO for Wi-Fi
- UART for Bluetooth
- SPI for 802.15.4

6.1 SDIO Interface

The SDIO interface of the PAN9019 / PAN9019A module is shown in the following figure:

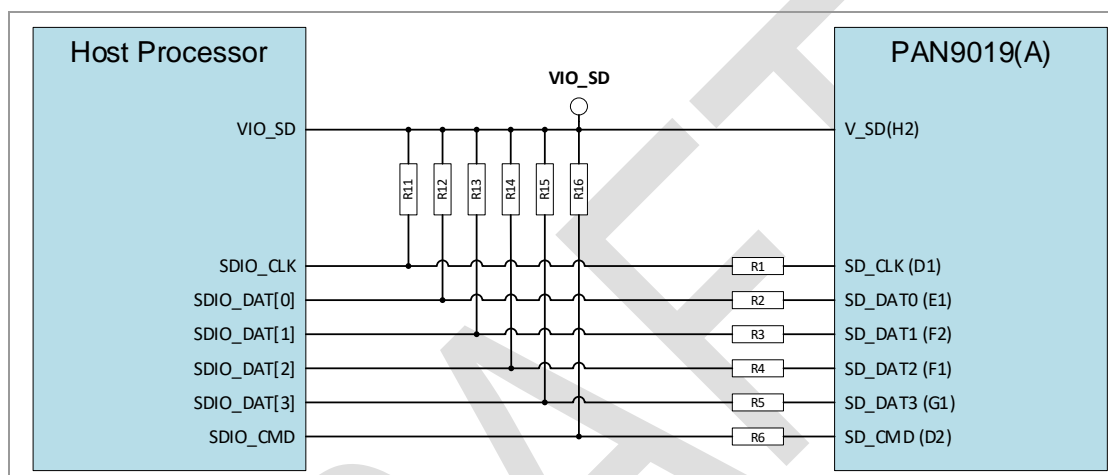

The block diagram includes pull-up resistors (R11 to R16) and series damping resistors (R1 to R6).

If the host processor includes internal pull-up resistors, resistors R11 to R16 are not required to be designed-in. In the case the host does not provide pull-resistors, please add pull-up resistors with a resistance of 10 k Ω to 100 k Ω .

The damping resistors R1 to R6 can help to reduce the under-/overshoot, if long ribbon cables are used for connecting the PAN9019 / PAN9019A. If required, 33 Ω resistors should be used. If the signal integrity shows good performance, it is not required to design-in these resistors.

6.2 UART Interface

The PAN9019 / PAN9019A includes a standard UART interface with flow control for operating the Bluetooth radio. In the following, two connection scenarios to host processors are described. The figure below shows a host that is operated as serial Data Communication Equipment (DCE). In this case, the CTS and RTS hardware flow control lines have a different direction than the standard UART interface.

 **Host Pin Assignment in DCE Mode**

Please be aware that hosts that operate the serial interface as DCE (Data Communication Equipment) or DTE (Data Terminal Equipment) usually switch the pins for Tx and Rx based on the mode. Ensure that the pins are used as assigned in DCE mode.

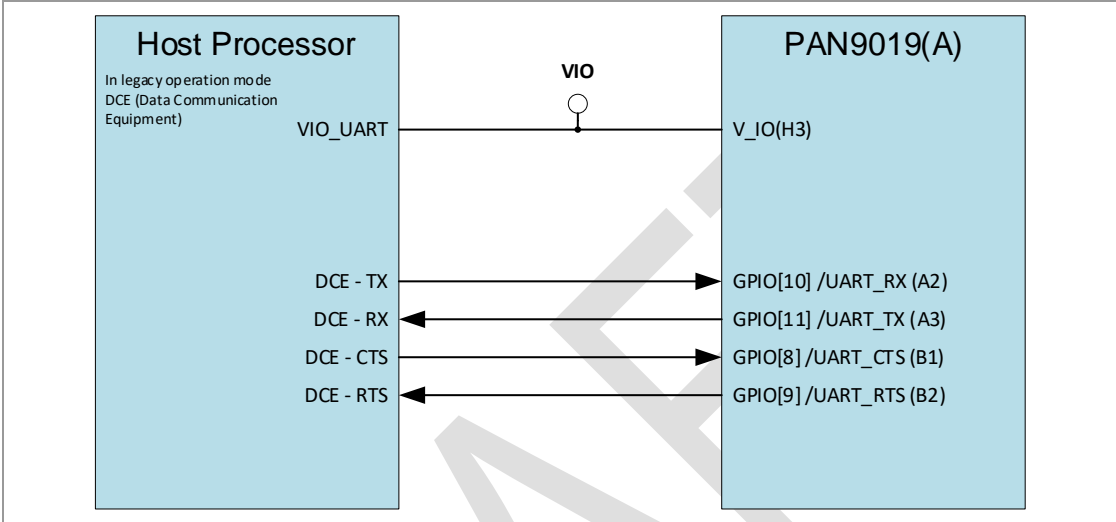

If the host processor provides a standard UART interface, the pins have a static pin assignment and the interface's lines are "crossed" by the hardware connection. The standard UART connection is illustrated in the following figure:

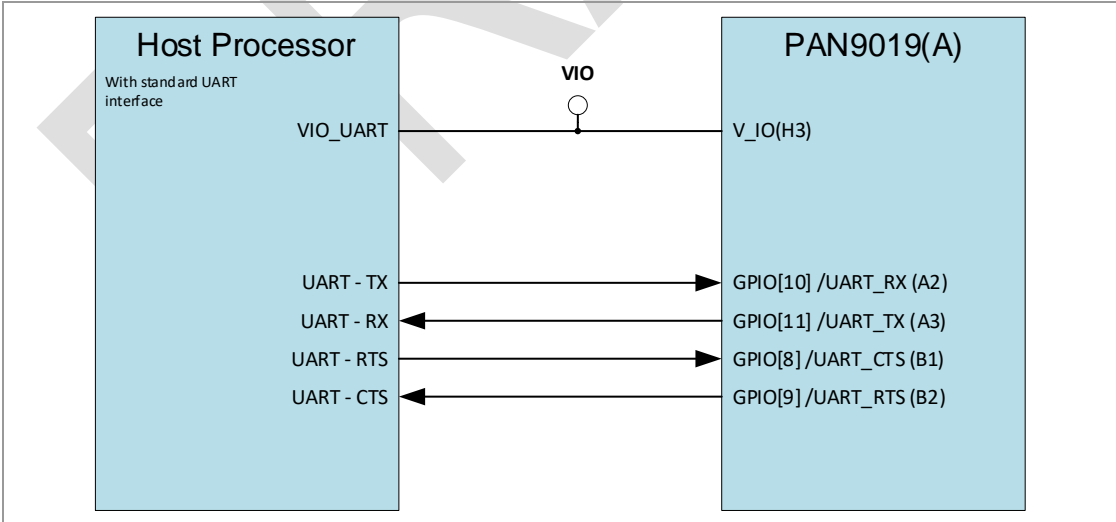

6.3 SPI Interface

In addition to the SDIO and UART interfaces, there is a Serial Peripheral Interface (SPI) on the PAN9019A module. This is used for operating the 802.15.4 radio. Besides the usual four SPI lines, there is the “SPI_INT” line. The PAN9019A uses “SPI_INT” to indicate that there is data to transmit. The host needs to start the communication in this case. The 802.15.4 is usually operated via the spinel software module. This module requires the SPI_INT functionality.

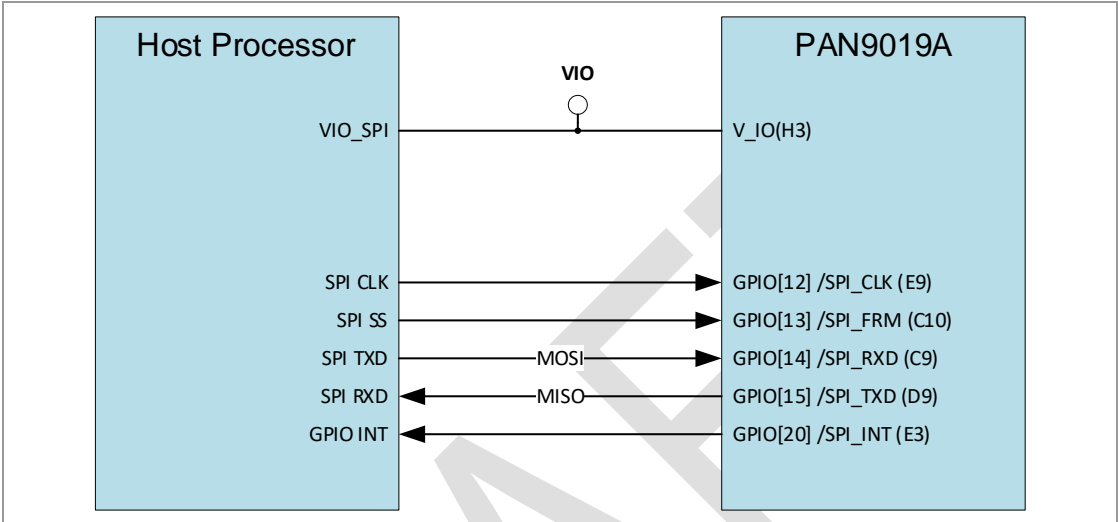

7 M.2 Reference Design



No SDIO Pull-Ups on the M.2 Designs

Please note that the M.2 reference designs do not contain pull-up resistors on the SDIO lines, because the host processor platforms usually provide these. For details please refer to [6.1 SDIO Interface](#).

7.1 Reference Schematics

7.1.1 M.2 Reference Design with MHF4 Connector

7.1.1.1 PAN9019

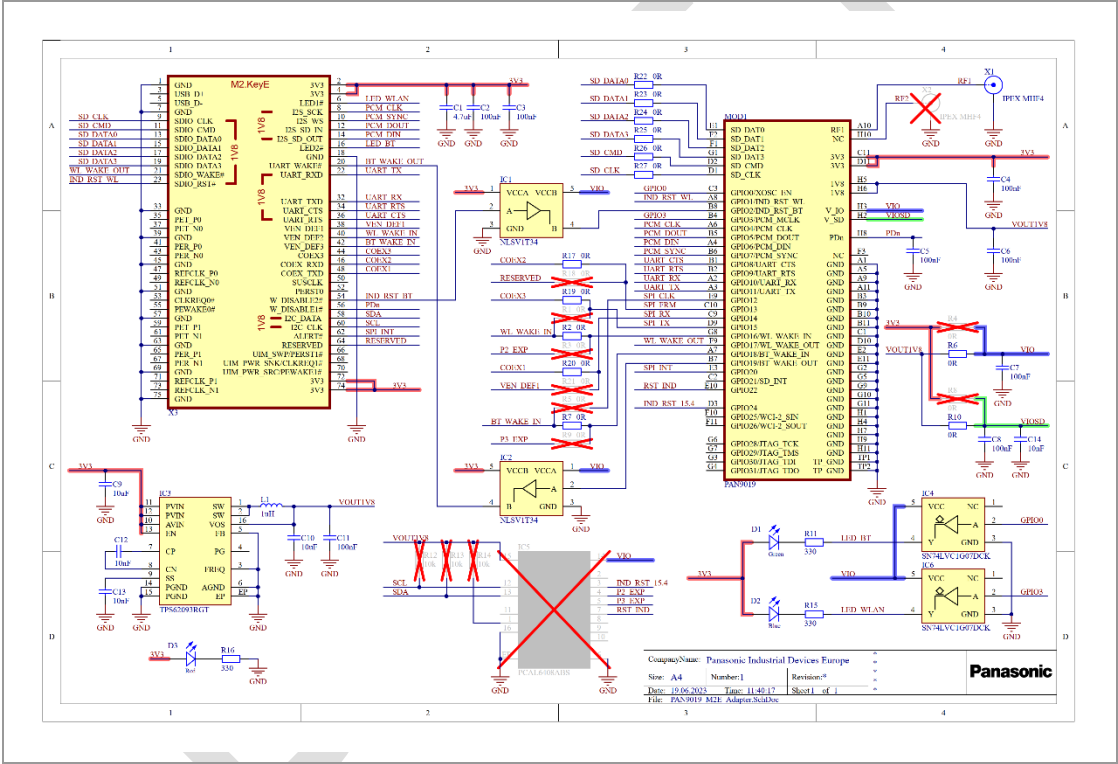

7.1.2.2 PAN9019A

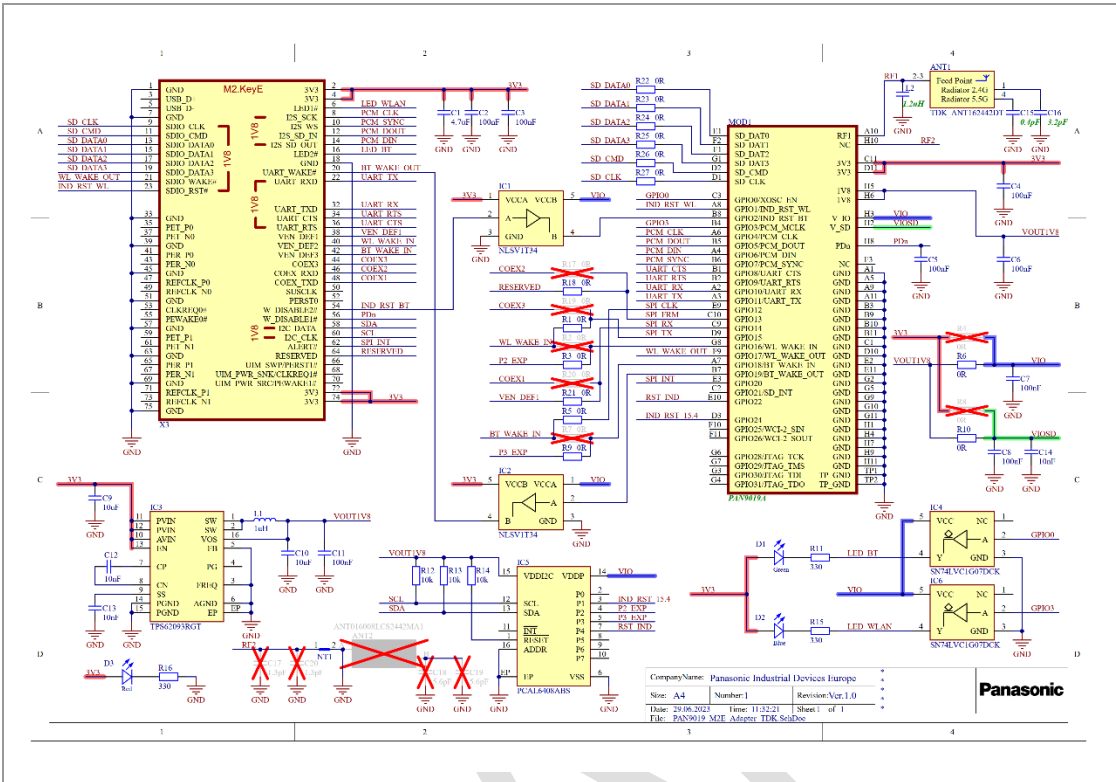

7.2 Reference Layout

This section shows the reference layout for a design with the described chip antenna. A layout for conducted RF interfaces can also use the information from the documented reference design.

Layer 1 (Top)

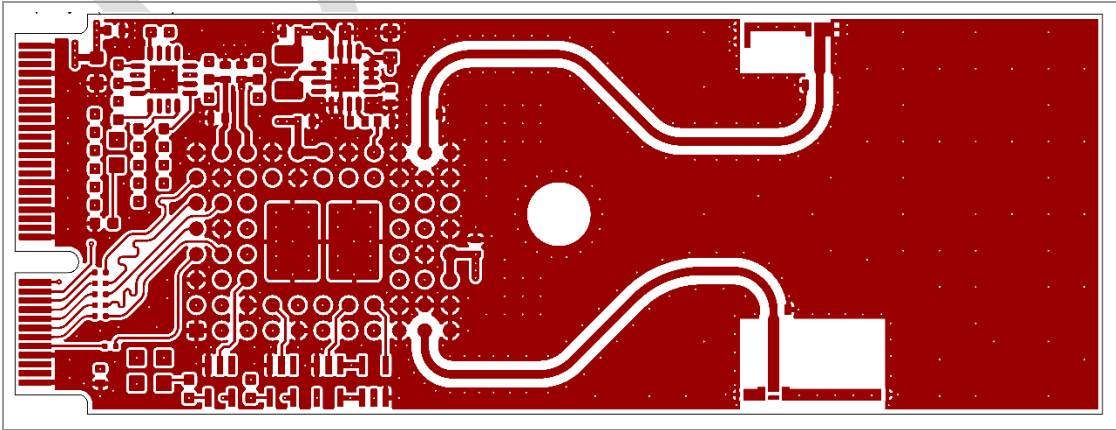

Layer 2

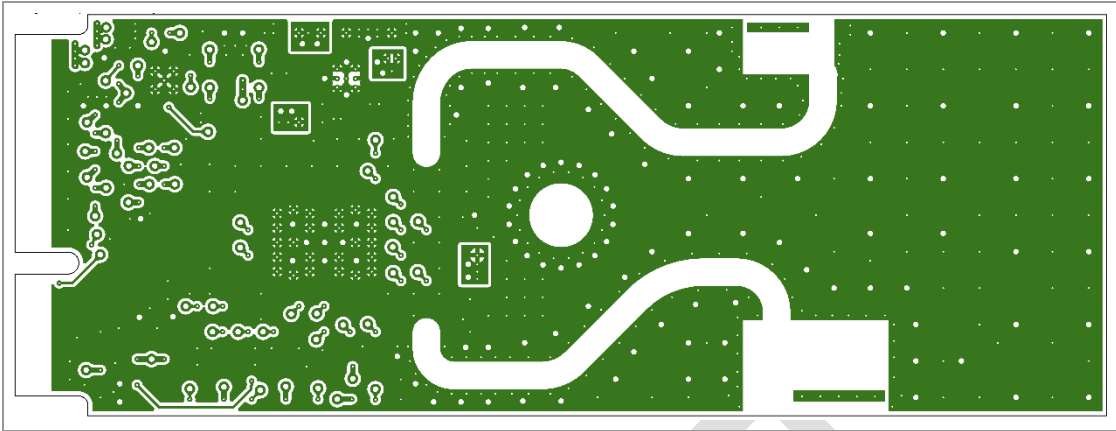

Layer 3

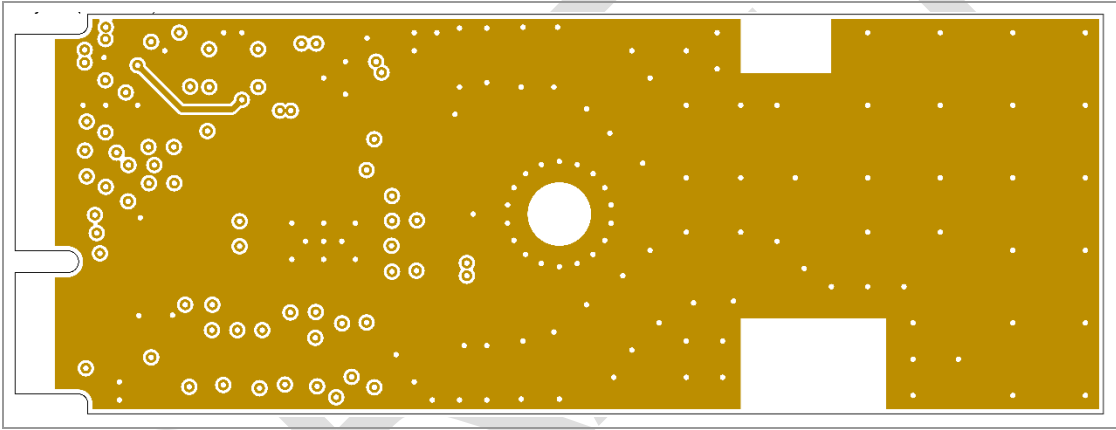

Layer 4

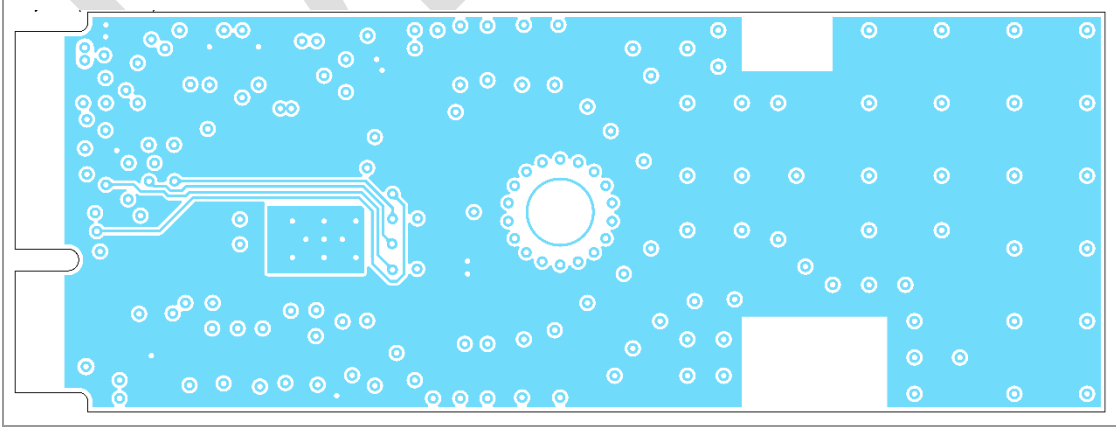

Layer 5

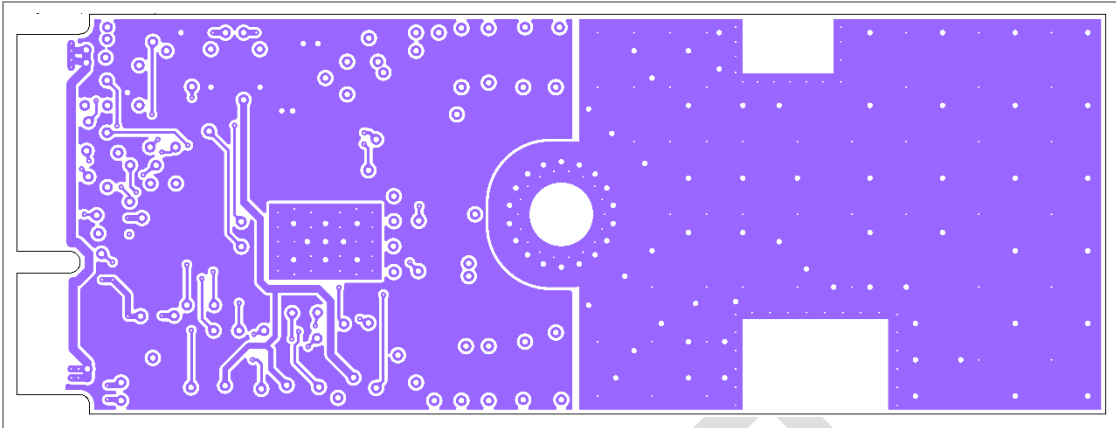

Layer 6 (Bottom)

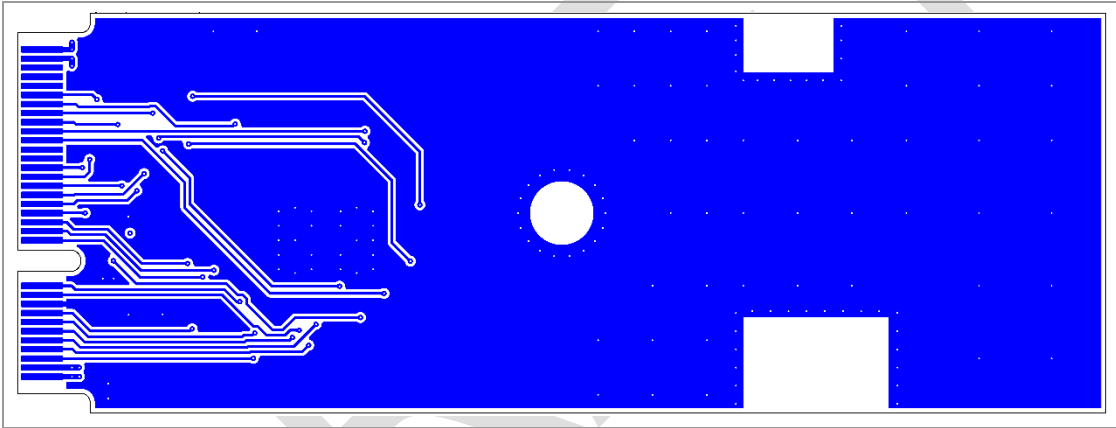

8 Software Integration

Following chapters describe how the radio interfaces can be brought up in such way that the regulatory requirements are met. The instructions must be followed for the modular approval to be valid.

8.1 Wi-Fi – Regulatory Compliant Bring Up

8.1.1 Concept



Self-Managed Interface Must be Used

Please be aware that the regulatory grant is only valid, if the driver is installed with the parameter `cntry_txpwr=2`. This ensures that the self-managed interface is used. A security key inside the PAN9019(A) ensures that the system is only operatable, if valid regulatory files are used.

For keeping the modular approval of the PAN9019(A) valid, it is only allowed to use the self-managed interface, which requires so-called rgpower files that contain regulatory settings, like e.g. Dynamic Frequency Selection (DFS) parameters and power settings for all modulations and channels.

The self-managed interface is used, if the driver (moal.ko) was installed with the parameter `cntry_txpwr` set to 2. Moreover, valid rgpower files must be present on the host system. After the start-up, the world-wide rgpower file (`rgpower_WW.bin`) is loaded, if it is available and valid. If the file cannot be loaded because it is not available or invalid, the start-up fails and it is not possible to operate the module.

In the intended case that the valid file is available, the device is ready for being operated with the world-wide settings initially applied. For extending the capabilities, the country code shall be changed to the country of operation by using the command `iw reg set` (US is used as an example). After the change was initiated, the related rgpower file is looked up. If this is available and valid, the settings are loaded and applied. In contrast, the world-wide file is loaded as a fallback, if the US file is not available or not valid. This behavior is illustrated in the figure below.



The drivers and firmware files are provided by NXP Semiconductors. Please ensure that a Board Support Package (BSP) version greater than 6.1.55-2.2.0 is used.



The regulatory files (`rgpower_XX.bin`) are provided by Panasonic.

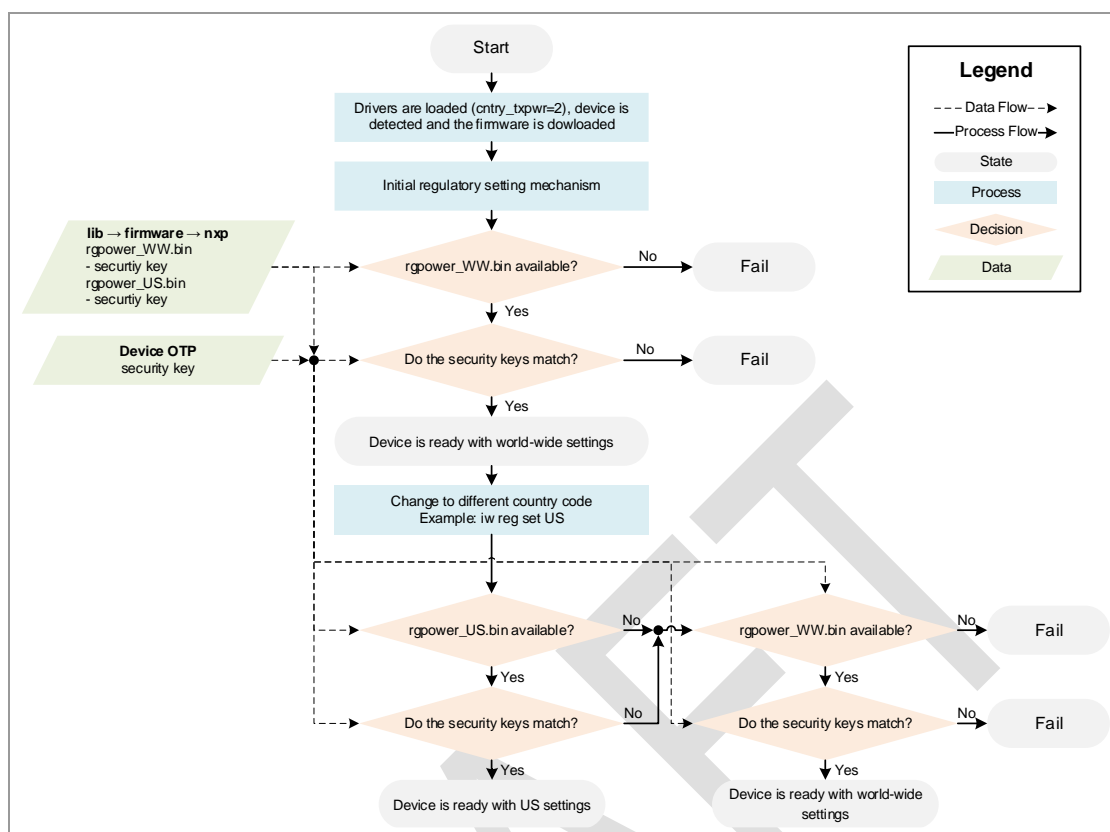

The required rgpower files are provided by Panasonic and contain a security key. The same key is stored in the PAN9019(A)'s One Time Programmable (OTP) memory. This ensures that only files, which comply with the respective regulations and standards, can be used. Please contact your local sales representative to obtain access to the files.

The world-wide file must be always present on the host system to act as fall-back with minimum settings (2.4 GHz Ch 1-11 only).

If required, additional restrictions can be applied via the WPA supplicant. For instance, indoor-only channels can be disabled, if the end-product shall be operated outdoor.

Details on the bring-up are described in the following sub-sections.

8.1.2 File Overview

The file structure on the linux host system is illustrated below. Following parts are present inside the `firmware -> nxp` folder:

- The firmware files
 - o `sduart_nw61x_v1.bin.se`: Wi-Fi, Bluetooth + 802.15.4 combo firmware
 - o `sd_w61x_v1.bin.se`: Wi-Fi only firmware
 - o `uartspi_n61x_v1.bin.se`: Bluetooth + 802.15.4 only firmware
- The rgpower files
 - o `rgpower_WW.bin`: World-wide file

- o `rgpower_US.bin`: File for the country of operation (US in this case)
- The driver parameter configuration file
 - o `wifi_mod_para.conf`: Configuration file that contains parameters for the driver installation (see ⇒ 8.1.3 Driver Parameters and ⇒ 8.1.4 Installing Drivers)

The drivers are located in the folder `extra`.

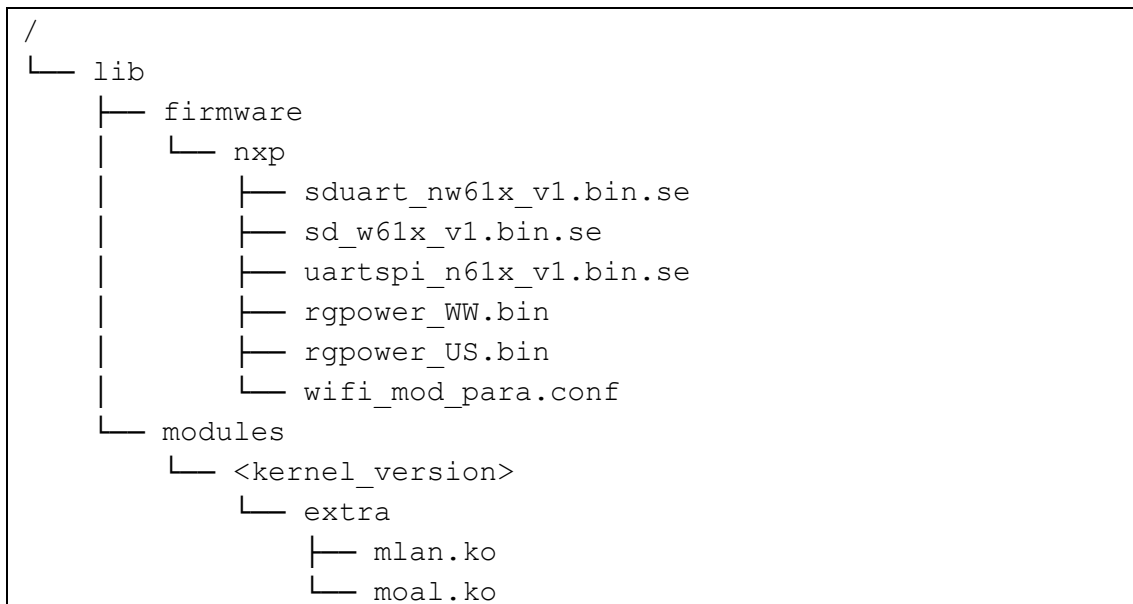

8.1.3 Driver Parameters

Three important parameters must be handed over during the installation of the driver. They can be contained in a configuration file (`wifi_mod_para.conf`) as shown below. Further parameters can be added, if required.

Important parameters:

- `cal_data_cfg` must be always **none** to use the calibration data from the module's OTP memory
- `centry_txpwr` must be always set to **2** to use the self-managed interface
- `fw_name` contains the firmware file name that shall be downloaded onto the module

```

...
SDIW612 = {
    cal_data_cfg=none
    centry_txpwr=2
    fw_name=nxp/sduart_nw61x_v1.bin.se
}
...
  
```

8.1.4 Installing Drivers

Following commands are used for installing the drivers. Always start with installing `m1an.ko` before installing `moal.ko` with the required parameters. The example below uses a parameter configuration file as introduced in ⇒ 8.1.3 Driver Parameters. All contained parameters are applied, when loading the drivers.

```
$ insmod /lib/modules/<kernel_version>/extra/m1an.ko
$ insmod /lib/modules/<kernel_version>/extra/moal.ko
mod_para=nxp/wifi_mod_para.conf
```

After the installation, the driver modules can be listed with the command `lsmod`. Moreover, the size and dependency of the modules is displayed.

```
$ lsmod
Module                Size      Used by
Moal                  831488    0
Mlan                  577536    1 moal
```

If the drivers are installed and a PAN9019(A) module was detected, the driver modules are loaded with the defined parameters, the firmware is loaded into the module and the system is set up for world-wide operation (`rgpower_ww.bin` is loaded). A log file of these steps is shown below.

```
wlan: Loading MWLAN driver
wlan: Register to Bus Driver...
wlan: Register to Bus Driver Done
wlan: Driver loaded successfully
mmc0: new ultra high speed SDR104 SDIO card at address 0001
vendor=0x0471 device=0x0205 class=0 function=1
Attach moal handle ops, card interface type: 0x109
rps set to 0 from module param
SDIW612: init module param from usr cfg
card_type: SDIW612, config block: 0
cal_data_cfg=none
centry_txpwr = 2
fw_name=nxp/sduart_nw61x_v1.bin.se
SDIO: max_segs=128 max_seg_size=65535
rx_work=1 cpu_num=4
Attach mlan adapter operations.card_type is 0x109.
wlan: Enable TX SG mode
wlan: Enable RX SG mode
Request firmware: nxp/sduart_nw61x_v1.bin.se
Wlan: FW download over, firmwarelen=918016 downloaded 841816
WLAN FW is active
on_time is 1653984027625
VDLL image: len=76200
fw_cap_info=0x487cff03, dev_cap_mask=0xffffffff
uuid: 707e337f287b5c19ac00ddf0c9b83a9f
max_p2p_conn = 8, max_sta_conn = 16
Trying download country_power_tble: nxp/rgpower_WW.bin
Request firmware: nxp/rgpower_WW.bin
call regulatory_set_wiphy_regd WW
call regulatory_set_wiphy_regd WW
Register NXP 802.11 Adapter mlan0
wlan: uap%d set max_mtu 2000
Register NXP 802.11 Adapter uap0
call regulatory_set_wiphy_regd WW
Register NXP 802.11 Adapter wfd0
wlan: version = SDIW612---18.99.2.p19.17-MM6X18408.p2-GPL-(FP92)
```

The detection and identification of the module is handled by the MMC-controller. Related detection modes are configured by the following properties in the device tree.

CD Property	Items	Description
non-removable (recommended)	None	The MMC-controller looks for a connected device at the start-up of the system. If detected, the device is identified and respective drivers are loaded. This mode is intended for statically fixed devices as the PAN9019(A) module. Please note that the module cannot be found if it is not present at start-up, or if it is restarted (e.g. by power cycling or asserting the PDn line) without rebooting the host system.
broken-cd	None	The MMC-controller regularly polls for a device. If detected, the device is identified and respective drivers are loaded. Please note that timing or stability issues can occur if this mode is used.
cd-gpio	CD GPIO	The MMC-controller checks the interface for a device after the card detect signal was asserted. The card detect signal is connected to the GPIO, which is defined as item of the property. The mode is usually used for removable SD cards and it is not recommended for non-removable devices as the PAN9019(A) module.

8.1.5 Loading rgpower Files

After a module was detected and the drivers were loaded, the system utilizes the world-wide settings. By calling the command `iw reg get`, the current configuration can be read out. The settings of the global interface are displayed first and the more important configuration of the self-managed interface at the end.

```

$ iw reg get
global
country 00: DFS-UNSET
    (755 - 928 @ 2), (N/A, 20), (N/A), PASSIVE-SCAN
    (2402 - 2472 @ 40), (N/A, 20), (N/A)
    (2457 - 2482 @ 20), (N/A, 20), (N/A), AUTO-BW, PASSIVE-SCAN
    (2474 - 2494 @ 20), (N/A, 20), (N/A), NO-OFDM, PASSIVE-SCAN
    (5170 - 5250 @ 80), (N/A, 20), (N/A), AUTO-BW, PASSIVE-SCAN
    (5250 - 5330 @ 80), (N/A, 20), (0 ms), DFS, AUTO-BW, PASSIVE-
SCAN
    (5490 - 5730 @ 160), (N/A, 20), (0 ms), DFS, PASSIVE-SCAN
    (5735 - 5835 @ 80), (N/A, 20), (N/A), PASSIVE-SCAN
    (57240 - 63720 @ 2160), (N/A, 0), (N/A)

phy#2 (self-managed)
country 00: DFS-UNSET
    (2402 - 2427 @ 20), (N/A, 19), (N/A)
    (2412 - 2462 @ 40), (N/A, 19), (N/A)
    (2447 - 2472 @ 20), (N/A, 19), (N/A)

```

To change to the configuration of the country, in which the device is operated, the command **iw reg set** can be used. The following example initiates a change to the US configuration.

```

$ iw reg set US

```

```

Trying download country_power_tble: nxp/rgpower_US.bin
Request firmware: nxp/rgpower_US.bin

```

After changing the country code, it can be observed that the self-managed interface has changed by calling **iw reg get**.

```
$ iw reg get
global
country US: DFS-FCC
    (902 - 904 @ 2), (N/A, 30), (N/A)
    (904 - 920 @ 16), (N/A, 30), (N/A)
    (920 - 928 @ 8), (N/A, 30), (N/A)
    (2400 - 2472 @ 40), (N/A, 30), (N/A)
    (5150 - 5250 @ 80), (N/A, 23), (N/A), AUTO-BW
    (5250 - 5350 @ 80), (N/A, 24), (0 ms), DFS, AUTO-BW
    (5470 - 5730 @ 160), (N/A, 24), (0 ms), DFS
    (5730 - 5850 @ 80), (N/A, 30), (N/A), AUTO-BW
    (5850 - 5895 @ 40), (N/A, 27), (N/A), NO-OUTDOOR, AUTO-BW, PASSIVE-SCAN
    (5925 - 7125 @ 320), (N/A, 12), (N/A), NO-OUTDOOR, PASSIVE-SCAN
    (57240 - 71000 @ 2160), (N/A, 40), (N/A)

phy#2 (self-managed)
country US: DFS-FCC
    (2402 - 2427 @ 20), (N/A, 19), (N/A)
    (2412 - 2462 @ 40), (N/A, 19), (N/A)
    (2447 - 2472 @ 20), (N/A, 19), (N/A)
    (5170 - 5250 @ 80), (N/A, 19), (N/A)
    (5250 - 5330 @ 80), (N/A, 19), (0 ms), DFS, PASSIVE-SCAN
    (5490 - 5730 @ 80), (N/A, 19), (0 ms), DFS, PASSIVE-SCAN
    (5735 - 5815 @ 80), (N/A, 19), (N/A)
    (5815 - 5835 @ 20), (N/A, 19), (N/A)
```

8.2 Bluetooth – Regulatory Compliant Bring Up



This chapter describes the Bluetooth bring up using the standard Linux Host Controller Interface (HCI) driver.

Please note that the NXP Bluetooth UART driver (btmnpuart) is not covered.

This section describes the bring-up of the Bluetooth system. As a prerequisite, the successful loading of the Wi-Fi/Bluetooth combo firmware through the module driver is expected (see [8.1 Wi-Fi – Regulatory Compliant Bring Up](#)). The module's Bluetooth system is controlled via the Host Controller Interface (HCI). Therefore, this must be attached to the corresponding UART interface as a first step. Following parameters should be set:

No	Parameter	Description
1	Serial Hardware Device	Specifies the serial device that shall be attached (e.g. <code>ttymxc0</code>)
2	Type	Should be <code>any</code> for hardware independent attachment
3	Baudrate	Select the baudrate of the module (initially 115200)
4	Flow Control	Use the keyword <code>flow</code> for hardware flow control (required)

```
# Example HCI attach
hciattach ttymxc0 any 115200 flow
```

After the HCI was attached to the respective UART interface, the HCI configuration is displayed on calling the command `hciconfig`. Below, you can see the `hciconfig`'s reply after successful `hciattach` but with the HCI still down.

```
hciconfig
hci0: Type: Primary Bus: UART
      BD Address: 34:32:E6:34:40:E7 ACL MTU: 1021:7 SCO MTU: 120:6
      DOWN
      RX bytes: 740 acl:0 sco: 0 events:43 errors:0
      TX bytes: 469 acl:0 sco: 0 commands:43 errors:0
```

Following command is used to start-up the HCI:

```
hciconfig hci0 up
```

Reading out the HCI configuration shows the interface up and running, after the HCI was started.

```
hciconfig
hci0: Type: Primary Bus: UART
      BD Address: 34:32:E6:34:40:E7 ACL MTU: 1021:7 SCO MTU: 120:6
      UP RUNNING
      RX bytes: 1544 acl:0 sco: 0 events:95 errors:0
      TX bytes: 1285 acl:0 sco: 0 commands:95 errors:0
```

Finally, the module's Bluetooth system can be operated (e.g. via the hcitool or a Bluetooth stack like e.g. BlueZ).

8.2.1 Setting the Bluetooth Power

PAN9019 and PAN9019A modules are prequalified and listed at the Bluetooth Special Interest Group (SIG). The output power must be limited to meet the listed power class and the regulatory requirements of the respective country/region. Following configuration are mandatory for compliance:

Country / Region	Bluetooth mode	Power Class	Configured Maximum Power (dBm)
US	Basic Rate / Enhanced Data Rate	1	8
	Low Energy	1	8
	Low Energy	1.5	4
CA	Basic Rate / Enhanced Data Rate	1	8
	Low Energy	1	8
	Low Energy	1.5	4
EU	Basic Rate / Enhanced Data Rate	1	3
	Low Energy	1.5	3
UK	Basic Rate / Enhanced Data Rate	1	3
	Low Energy	1.5	3
NZ	Basic Rate / Enhanced Data Rate	1	3
	Low Energy	1.5	3
AU	Basic Rate / Enhanced Data Rate	1	3
	Low Energy	1.5	3
JP	Basic Rate / Enhanced Data Rate	1	3
	Low Energy	1.5	3

There are already Bluetooth settings that are stored in the one-time-programmable (OTP) memory of the module at delivery. This includes the initial power, which is set to 3 dBm, and the NXP power class, which is set to class 1.5. To check, if the configurations are correct, they can be read out by the custom host controller interface (HCI) command `3f 62 37` as shown below. The initial power is the green marked byte and the power class is encoded in the red byte.

```

hcitool -i hci0 cmd 3f 62 37

HCI Event: 0x0e plen 33
01 62 FC 00 01 37 [CRC] 1c 00 00 00 00 00 01 [crystal] 03 03 08 00
00 00 00 c2 01 00 [BD0] [BD1] [BD2] [BD3] [BD4] [BD5] F0 00

```

Two bits of the red byte determine the NXP power class:

Bit	Name	Description
0	Force Class 2 Operation	If enabled, NXP class 2 is used If disabled, NXP class 1.5 or 1 is used depending on bit 9
9	Class 1 Operation Support	If bit 0 is zero: Disabled -> NXP class 1.5 is used Enabled -> NXP class 1 is used

Following table gives an overview about the NXP power classes (not identical to the Bluetooth power classes):

NXP Power Class	Minimum Configurable Power (dBm)	Maximum Configurable Power (dBm)	Notes
1	-13	+19	Bluetooth Enhanced Data Rate Power is reduced by appr. 9 dB
1.5	-20	+13	Bluetooth Enhanced Data Rate Power is reduced by appr. 3 dB
2	-20	+3	Bluetooth Enhanced Data Rate Power is equal to the Basic Rate Power

Below, the Bluetooth power classes are depicted. The given maximum equivalent isotropically radiated power (E.I.R.P.) is not a measurement limit, but the theoretical value resulting from the configured maximum power and the antenna gain.

Technology	Bluetooth Power Class	Maximum E.I.R.P. (dBm) Shall Be Greater Than	Maximum E.I.R.P. (dBm) Shall Be Smaller Than
Basic Rate & Enhanced Data Rate	1	4	20
	2	0	4
	3	-	0
Low Energy	1	10	20
	1.5	4	10
	2	0	4
	3	-	0

From the tables above and an antenna gain range of 2.0 to 5.2 dBi, it can be derived that the NXP power classes 1 and 1.5 can be used. Because the NXP class 1.5 shows a smaller

difference (3 dB) between the Bluetooth Basic Rate and Bluetooth Enhanced Data Rate power, it is the recommended NXP power class.

The preconfigured settings of the NXP class 1.5 and an initial power of 3 dBm can be kept to meet the regulatory requirements after startup and being still able to adjust the power limit depending on the country. In case that the Bluetooth settings shall be changed anyway, this can be done by using the HCI command **3F 61**. Please note that the settings do also include device related settings like e.g. the BD address and XTAL calibration value. Therefore, the OTP data shall be read out and the device related settings shall be adopted when writing the new data. It is not required to calculate the CRC as this field is ignored when writing new data.

```
##### Optional Change of the Bluetooth Configuration Data #####
# Read out the OTP data
hcitool -i hci0 cmd 3f 62 37

HCI Event: 0x0e plen 33
01 62 FC 00 01 37 [CRC] 1C 00 00 00 00 00 01 [crystal] 03 03 08 00
00 00 00 C2 01 00 [BD0] [BD1] [BD2] [BD3] [BD4] [BD5] F0 00

# Write the new Bluetooth data
hcitool -i hci0 cmd 3F 61 00 00 01 1C 37 [CRC] 1C 00 00 00 00 00 01
[crystal] [Init. Power in dB] 03 [Configuration Byte] 00 00 00 00 C2
01 00 [BD0] [BD1] [BD2] [BD3] [BD4] [BD5] F0 00

# Reset the HCI Inteface
hcitool -i hci0 cmd 03 03
```

8.2.1.1 Configuring the Bluetooth Basic Rate and Enhanced Data Rate Power

The power limit can be changed by the HCI command **3F EE**. If not applied, the initial power is used as limit. Please note that the power for Bluetooth Enhanced Data Rate is reduced depending on the NXP power class (about 3 dB with class 1.5). The command has following parameters:

Parameter	Name	Description
1	Maximum Power Selction	<ul style="list-style-type: none"> - 0x00: Default behavior. Maximum power is set to physical maximum power level - 0x01: Updates Maximum power based on parameter 2 - Other values: Invalid. HCI_ERR_INVALID_PARAMETERS error is returned
2	User-defined Maximum Power Value	<p>The parameter is ignored when the first parameter (maximum power selection) is 0.</p> <ul style="list-style-type: none"> - 127: Maximum power is updated by the power value calculated from the Initial power and FE loss parameters stored in Cal-data. - Signed value of TX power (dBm) in the range -20 to 19 - Other values: Error is returned

The following example shows the configuration of a 3 dBm power limit.

```
# Configure 3 dBm as power limit
hcidtool -i hci0 cmd 3f ee 01 03

# Reset the HCI Inteface
hcidtool -i hci0 cmd 03 03
```

For regions like the US, the power limit can be enlarged to 8 dBm:

```
# Configure 8 dBm as power limit
hcidtool -i hci0 cmd 3f ee 01 08

# Reset the HCI Inteface
hcidtool -i hci0 cmd 03 03
```

8.2.1.2 Configuring the Bluetooth Low Energy Power

The power limit for Bluetooth low energy can be changed by the HCI command **3F 87**. If not applied, the initial power setting is used as limit. There is only one parameter, which is the power limit in dBm. Following this, the power can be limited to 3 dBm by using following command sequence:

```
# Configure 3 dBm as power limit
hcitool -i hci0 cmd 3f 87 03

# Reset the HCI Inteface
hcitool -i hci0 cmd 03 03
```

For regions like the US, the power limit can be enlarged to 8 dBm:

```
# Configure 8 dBm as power limit
hcitool -i hci0 cmd 3f 87 08

# Reset the HCI Inteface
hcitool -i hci0 cmd 03 03
```

8.2.2 Changing the UART Baud Rate

At delivery, the device operates the UART interface with the baud rate 115200. This ensures that host devices with limited UART interface capabilities can operate the PAN9019(A) module. While granting a wide compatibility, the low baud rate limits the data throughput and thus excludes some features like audio profiles. Therefore, the baud rate must be enlarged if a high data throughput is required. This can be done by using the HCI command **3F 09**. The command expects the baud rate in hexadecimal format with the least significant byte at the first position. After the change, the HCI must be detached from the UART interface and attached again with the new baud rate. Please note that the `killall` command must be used with option `-9` to force the process to end. Below, an example that changes the baud rate to 3M is shown.

```
# The HCI was attached with the initial baud rate of 115200.
# => Change the baud rate to 3M
# hcitool -i hci0 cmd 3f 09 [Baud0] [Baud1] [Baud2] [Baud3]
hcitool -i hci0 cmd 3f 09 C0 C6 2D 00

# Shut down the HCI attachment immediately (option -9)
killall -9 hciattach

# Attach the HCI to the UART interface with the new baud rate (3M)
hciattach ttyMXC0 any 3000000 flow

# Start the HCI interface
hciconfig hci0 up
```

8.3 802.15.4 – Regulatory Compliant Bring Up

When using 802.15.4, the maximum output power must be configured to meet the regulatory requirements of the respective country/region. Following configuration are mandatory for compliance:

Country / Region	Configured Maximum Power (dBm)
US	8
CA	8
EU	4
UK	4
NZ	4
AU	4
JP	4

The following section describes how the maximum power levels can be configured.

8.3.1 Setting the 802.15.4 Power

At delivery of the module, the power is not limited by software. OEMs must limit the power in there software according to the limits stated in this document and depending on the country/region of operation. A configuration using the open thread stack is documented in the following.

The open thread command `txpwrlimit` expects the power limit in steps of 0.5 dB. Thus, the power can be limited to 8 dBm by the command below.

```
$ ot-ctl txpwrlimit 16
```

4 dBm are used as power limit if the command below is applied.

```
$ ot-ctl txpwrlimit 8
```

The power limit must be configured directly after start-up and before performing any 802.15.4 operation. Moreover, the limit must be kept through the entire operation. To configure and vary the Tx power during operation, the command `txpower` can be used. This expects a power value in dB. It is not possible to configure a Tx power that is higher than the power limit. As an example, the configuration of a Tx power of 6 dBm is shown below.

```
$ ot-ctl txpower 6
```

DRAFT

9 Contact Details

9.1 Contact Us

Please contact your local Panasonic Sales office for details on additional product options and services:

For Panasonic Sales assistance in the **EU**, visit

<https://eu.industrial.panasonic.com/about-us/contact-us>

Email: wireless.connectivity@eu.panasonic.com

For Panasonic Sales assistance in **North America**, visit the Panasonic website “Sales & Support” to find assistance near you at

<https://na.industrial.panasonic.com/distributors>

For information about evaluation tools, schematics, software development, and more, please visit the “Panasonic Wireless Connectivity Development Hub”

<https://pideu.panasonic.de/development-hub/>.

9.2 Product Information

For further information on our products and related documents please refer to the Panasonic Wireless Connectivity website:

For complete Panasonic product details in the **EU**, visit

<https://industry.panasonic.eu/>

For complete Panasonic product details in **North America**, visit

<http://www.panasonic.com/rfmodules>