



FCC PART 15.247

TEST REPORT

For

**RTX Hong Kong Ltd.**

8/F Corporation Square, 8 Lam Lok Street, Kowloon Bay, Hong Kong

**FCC ID: T7HCT816X**

<b>Report Type:</b> Original Report	<b>Product Type:</b> DECT handset
<b>Report Number:</b> <u>RSZ161123010-00B</u>	
<b>Report Date:</b> <u>2017-04-24</u>	
Oscar Ye 	
<b>Reviewed By:</b> <u>Engineer</u>	
<b>Prepared By:</b> Bay Area Compliance Laboratories Corp. (Kunshan) No.248 Chenghu Road, Kunshan, Jiangsu province, China Tel: +86-0512-86175000 Fax: +86-0512-88934268 <a href="http://www.baclcorp.com.cn">www.baclcorp.com.cn</a>	

**Note:** This test report is prepared for the customer shown above and for the device described herein. It may not be duplicated or used in part without prior written consent from Bay Area Compliance Laboratories Corp.

## TABLE OF CONTENTS

<b>GENERAL INFORMATION.....</b>	<b>4</b>
PRODUCT DESCRIPTION FOR EQUIPMENT UNDER TEST (EUT).....	4
OBJECTIVE.....	4
RELATED SUBMITTAL(S)/GRANT(S).....	4
TEST METHODOLOGY.....	4
MEASUREMENT UNCERTAINTY.....	5
TEST FACILITY.....	5
<b>SYSTEM TEST CONFIGURATION.....</b>	<b>6</b>
DESCRIPTION OF TEST CONFIGURATION.....	6
EQUIPMENT MODIFICATIONS.....	6
EUT EXERCISE SOFTWARE.....	6
DUTY CYCLE.....	7
SUPPORT EQUIPMENT LIST AND DETAILS.....	7
EXTERNAL I/O CABLE.....	7
BLOCK DIAGRAM OF TEST SETUP.....	8
<b>SUMMARY OF TEST RESULTS.....</b>	<b>9</b>
<b>TEST EQUIPMENT LIST.....</b>	<b>10</b>
<b>FCC§15.247 (i), §1.1307 (b) (1) &amp; §2.1093 – RF EXPOSURE.....</b>	<b>11</b>
APPLICABLE STANDARD.....	11
<b>FCC §15.203 - ANTENNA REQUIREMENT.....</b>	<b>12</b>
APPLICABLE STANDARD.....	12
ANTENNA CONNECTOR CONSTRUCTION.....	12
<b>FCC §15.207 (a) – AC LINE CONDUCTED EMISSIONS.....</b>	<b>13</b>
APPLICABLE STANDARD.....	13
EUT SETUP.....	13
EMI TEST RECEIVER SETUP.....	13
TEST PROCEDURE.....	13
CORRECTED FACTOR & MARGIN CALCULATION.....	14
TEST RESULTS SUMMARY.....	14
TEST DATA.....	14
<b>FCC §15.209, §15.205 &amp; §15.247(d) - SPURIOUS EMISSIONS.....</b>	<b>17</b>
APPLICABLE STANDARD.....	17
EUT SETUP.....	17
EMI TEST RECEIVER & SPECTRUM ANALYZER SETUP.....	18
TEST PROCEDURE.....	18
CORRECTED AMPLITUDE & MARGIN CALCULATION.....	18
TEST RESULTS SUMMARY.....	18
TEST DATA.....	19
<b>FCC §15.247(a) (2) – 6 dB EMISSION BANDWIDTH.....</b>	<b>22</b>
APPLICABLE STANDARD.....	22
TEST PROCEDURE.....	22
TEST DATA.....	22

**FCC §15.247(b) (3) - MAXIMUM CONDUCTED OUTPUT POWER.....25**  
    APPLICABLE STANDARD .....25  
    TEST PROCEDURE .....25  
    TEST DATA .....25

**FCC §15.247(d) – 100 kHz BANDWIDTH OF FREQUENCY BAND EDGE.....26**  
    APPLICABLE STANDARD .....26  
    TEST PROCEDURE .....26  
    TEST DATA .....26

**FCC §15.247(e) - POWER SPECTRAL DENSITY .....28**  
    APPLICABLE STANDARD .....28  
    TEST PROCEDURE .....28  
    TEST DATA .....28

---

## GENERAL INFORMATION

---

### Product Description for Equipment under Test (EUT)

The *RTX Hong Kong Ltd.*'s product, model number: *RTX8162 EX (FCC ID: T7HCT816X)* in this report is a *DECT handset*, which was measured approximately: 13.4 cm (L) \* 5.5 cm (W) \* 3.0 cm (H), rated with input voltage: DC3.7V battery.

#### Battery information:

Model: RTX816x EX Battery Pack

Rating: 3.7V 1100mAh 4.2Wh (Li-ion rechargeable battery)

*Note: For the product, series model RTX8162 EX, 8262 EX DECT Handset, RTX8161 EX and RTX816x EX have the same electrical designs, construction design, PCB, produced at same location, RTX8162 EX was selected for fully testing, the detailed differences between them were explained and stated in the attached product similarity declaration letter by the applicant.*

*\* All measurement and test data in this report was gathered from production sample serial number: 1603746 (Assigned by BAACL, Kunshan). The EUT supplied by the applicant was received on 2016-11-23.*

### Objective

This report is prepared on behalf of *RTX Hong Kong Ltd.* in accordance with Part 2-Subpart J, Part 15-Subparts A and C of the Federal Communication Commission's rules.

The tests were performed in order to determine compliance with FCC Part 15, Subpart C, and section 15.203, 15.205, 15.207, 15.209 and 15.247 rules.

### Related Submittal(s)/Grant(s)

FCC Part 15.247 DSS and FCC Part 15D PUE submissions with FCC ID: T7HCT816X.

The DECT base Unit of a system submission with FCC ID: T7HX8660.

### Test Methodology

All measurements contained in this report were conducted with ANSI C63.10-2013, American National Standard of Procedures for Compliance Testing of Unlicensed Wireless Devices.

All emissions measurement was performed at Bay Area Compliance Laboratories Corp. (Kunshan). The radiated testing was performed at an antenna-to-EUT distance of 3 meters.

### Measurement Uncertainty

Item		Uncertainty
AC Power Lines Conducted Emissions		±3.26 dB
RF conducted test with spectrum		±0.9dB
RF Output Power with Power meter		±0.5dB
Radiated emission	30MHz~1GHz	±5.91dB
	Above 1G	±4.92dB
Occupied Bandwidth		±0.5kHz
Temperature		±1.0°C
Humidity		±6%

### Test Facility

The Test site used by Bay Area Compliance Laboratories Corp. (Kunshan) to collect test data is located on the No.248 Chenghu Road, Kunshan, Jiangsu province, China

Bay Area Compliance Laboratories Corp. (Kunshan) has been accredited to ISO/IEC 17025 by CNAS(Lab code: L9963). And accredited to ISO/IEC 17025 by A2LA(Lab code: 4323.01), the FCC Designation No. CN1185 under the KDB 974614 D01.

The Federal Communications Commission has the reports on file and is listed under FCC Registration No.: 815570. The test site has been approved by the FCC for public use and is listed in the FCC Public Access Link (PAL) database.

Bay Area Compliance Laboratories Corp. (Kunshan) was registered with ISED Canada under ISED Canada Registration Number 3062E.

## SYSTEM TEST CONFIGURATION

### Description of Test Configuration

For BLE mode, 40 channels are provided to testing

Channel	Frequency (MHz)	Channel	Frequency (MHz)
0	2402	20	2442
1	2404	21	2444
2	2406	22	2446
3	2408	23	2448
4	2410	24	2450
5	2412	25	2452
6	2414	26	2454
7	2416	27	2456
8	2418	28	2458
9	2420	29	2460
10	2422	30	2462
11	2424	31	2464
12	2426	32	2466
13	2428	33	2468
14	2430	34	2470
15	2432	35	2472
16	2434	36	2474
17	2436	37	2476
18	2438	38	2478
19	2440	39	2480

EUT was tested with Channel 0, 19 and 39.

### Equipment Modifications

No modification was made to the EUT tested.

### EUT Exercise Software

Software "blue test 3" was used.

**Duty cycle**

**BLE Mode**

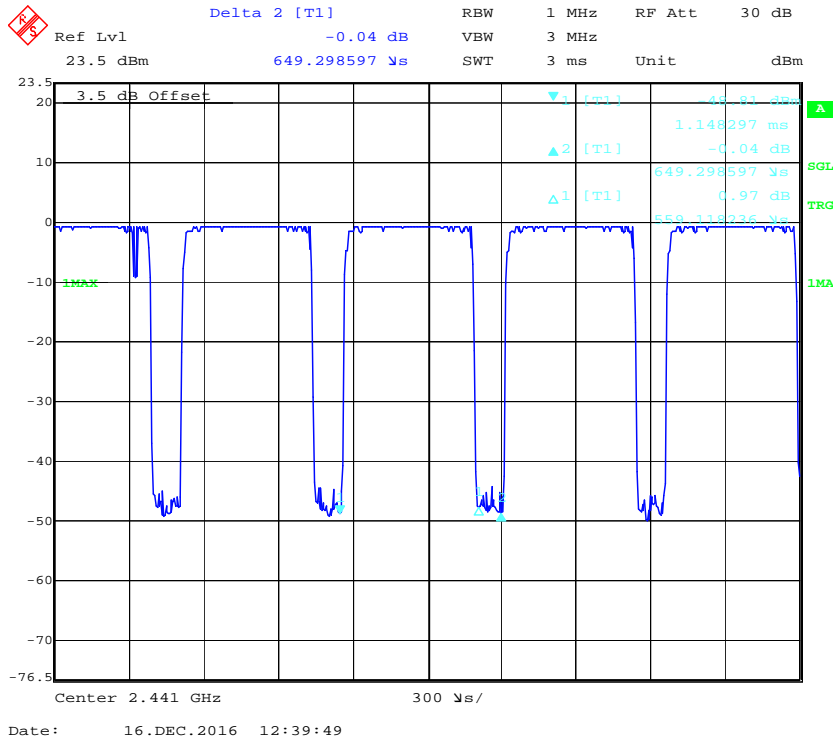

Band	Duty Cycle (%)	T(us)	1/T(kHz)	VBW Setting	10log(1/x)
BLE	86	559	1.79	3kHz	0.66

**Support Equipment List and Details**

Manufacturer	Description	Model	Serial Number
NEC	Charger	Gx66/i766 Enh	0003481100120

**External I/O Cable**

Cable Description	Length (m)	From Port	To
Un-shielding Detachable USB Cable	1.5	EUT	Adapter

### Block Diagram of Test Setup

For conducted emission

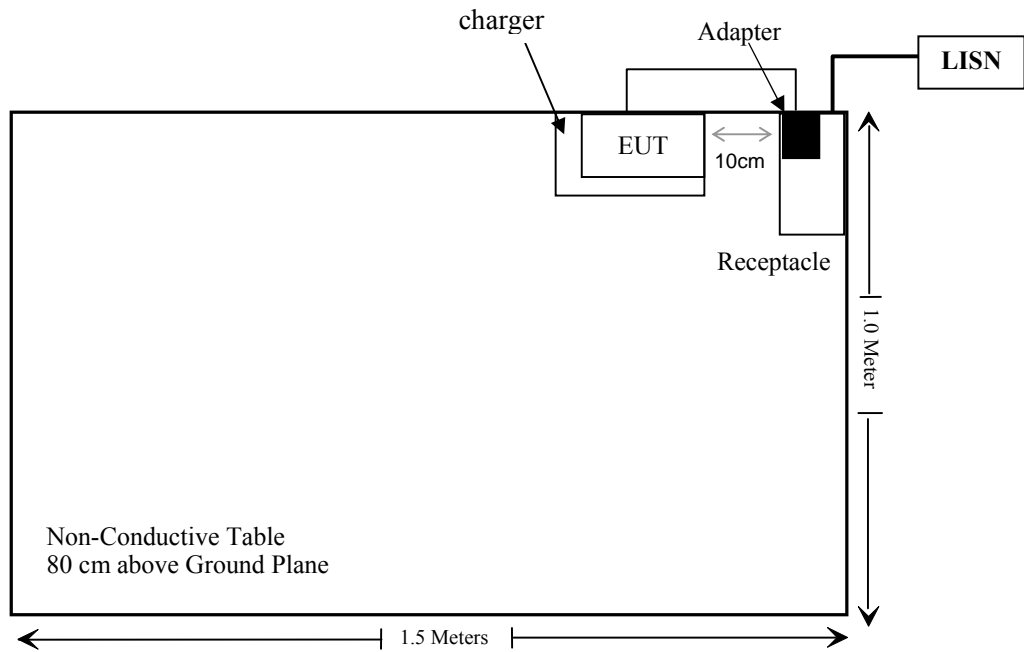



**SUMMARY OF TEST RESULTS**

<b>FCC Rules</b>	<b>Description of Test</b>	<b>Result</b>
§15.247 (i), §1.1307 (b) (1)& §2.1093	RF Exposure	Compliance
§15.203	Antenna Requirement	Compliance
§15.207 (a)	AC Line Conducted Emissions	Compliance
§15.205, §15.209, §15.247(d)	Spurious Emissions	Compliance
§15.247 (a)(2)	6 dB Emission Bandwidth	Compliance
§15.247(b)(3)	Maximum Conducted Output Power	Compliance
§15.247(d)	100 kHz Bandwidth of Frequency Band Edge	Compliance
§15.247(e)	Power Spectral Density	Compliance

**TEST EQUIPMENT LIST**

Manufacturer	Description	Model	Serial Number	Calibration Date	Calibration Due Date
<b>AC Line Conducted test</b>					
Rohde & Schwarz	EMI Test Receiver	ESCS30	834115/007	2016-11-25	2017-11-25
Rohde & Schwarz	LISN	ESH3-Z5	862770/011	2016-10-10	2017-10-10
Rohde & Schwarz	Pulse limiter	ESH3-Z2	879940/0058	2016-06-19	2017-06-18
MICRO-COAX	Coaxial line	UFB-293B-1-0480-50X50	97F0173	2016-09-08	2017-09-08
Rohde & Schwarz	CE Test software	EMC 32	V 09.10.0	NCR	NCR
<b>Radiation test</b>					
Sonoma Instrument	Amplifier	330	171377	2016-12-12	2017-12-12
Rohde & Schwarz	EMI Test Receiver	ESCI	100195	2016-11-25	2017-11-25
Sunol Sciences	Broadband Antenna	JB3	A090314-2	2016-01-09	2019-01-08
Narda	Pre-amplifier	AFS42-00101800	2001270	2016-09-08	2017-09-08
EMCO	Horn Antenna	3116	00084159	2016-10-18	2019-10-17
Rohde & Schwarz	Signal Analyzer	FSIQ26	100048	2016-11-25	2017-11-25
ETS	Horn Antenna	3115	6229	2016-01-11	2019-01-10
R&S	Auto test Software	EMC32	V 09.10.0	NCR	NCR
haojintech	Coaxial Cable	Cable-1	001	2016-12-12	2017-12-12
haojintech	Coaxial Cable	Cable-2	002	2016-12-12	2017-12-12
haojintech	Coaxial Cable	Cable-3	003	2016-12-12	2017-12-12
MICRO-COAX	Coaxial Cable	Cable-4	004	2016-12-12	2017-12-12
MICRO-COAX	Coaxial Cable	Cable-5	005	2016-12-12	2017-12-12
<b>RF Conducted test</b>					
BACL	TS 8997 Cable-01	T-KS-EMC086	T-KS-EMC086	2016-12-09	2017-12-08
BACL	RF cable	KS-LAB-012	KS-LAB-012	2016-12-15	2017-12-15
WEINSCHEL	3dB Attenuator	5326	N/A	2016-06-18	2017-06-18
Agilent	Power Meter	N1912A	MY5000492	2016-11-17	2017-11-16
Agilent	Power Sensor	N1921A	MY54210024	2016-11-17	2017-11-16
Rohde & Schwarz	Signal Analyzer	FSIQ26	836131/009	2016-09-21	2017-09-21

\* **Statement of Traceability:** Bay Area Compliance Laboratories Corp. (Kunshan) attests that all calibrations have been performed in accordance to requirements that traceable to National Primary Standards and International System of Units (SI).

**FCC§15.247 (i), §1.1307 (b) (1) & §2.1093 – RF EXPOSURE**

**Applicable Standard**

According to FCC §2.1093 and §1.1307(b) (1), systems operating under the provisions of this section shall be operated in a manner that ensure that the public is not exposed to radio frequency energy level in excess of the Commission’s guideline.

According to KDB 447498 D01 General RF Exposure Guidance

The 1-g and 10-g SAR test exclusion thresholds for 100 MHz to 6 GHz at test separation distances ≤ 50 mm are determined by:

$$[(\text{max. power of channel, including tune-up tolerance, mW})/(\text{min. test separation distance, mm})] \cdot [\sqrt{f(\text{GHz})}] \leq 3.0 \text{ for 1-g SAR and } \leq 7.5 \text{ for 10-g extremity SAR, where}$$

1. f(GHz) is the RF channel transmit frequency in GHz.
2. Power and distance are rounded to the nearest mW and mm before calculation.
3. The result is rounded to one decimal place for comparison.
4. When the minimum test separation distance is < 5 mm, a distance of 5 mm is applied to determine SAR test Exclusion.

**Measurement Result**

**For worst case:**

Frequency (MHz)	Max Tune-up Conducted Power (dBm)	Max Tune-up Conducted Power (mW)	Calculated Distance (mm)	Calculated value	Threshold (1-g SAR)	SAR Test Exclusion
2480	2.0	1.58	5	0.5	3.0	Yes

**Result: No SAR test is required**

---

## **FCC §15.203 - ANTENNA REQUIREMENT**

---

### **Applicable Standard**

According to § 15.203, an intentional radiator shall be designed to ensure that no antenna other than that furnished by the responsible party shall be used with the device. The use of a permanently attached antenna or of an antenna that uses a unique coupling to the intentional radiator shall be considered sufficient to comply with the provisions of this section. The manufacturer may design the unit so that a broken antenna can be replaced by the user, but the user of a standard antenna jack or electrical connector is prohibited. The structure and application of the EUT were analyzed to determine compliance with section §15.203 of the rules. §15.203 state that the subject device must meet the following criteria:

- a. Antenna must be permanently attached to the unit.
- b. Antenna must use a unique type of connector to attach to the EUT.

Unit must be professionally installed, and installer shall be responsible for verifying that the correct antenna is employed with the unit.

And according to FCC 47 CFR section 15.247 (b), if the transmitting antennas of directional gain greater than 6dBi are used, the power shall be reduced by the amount in dB that the directional gain of the antenna exceeds 6 dBi.

### **Antenna Connector Construction**

The EUT has an internal antenna arrangement, which was permanently attached and the antenna gain is 0 dBi, fulfill the requirement of this section. Please refer to the EUT photos.

**Result:** Compliance.

**FCC §15.207 (a) – AC LINE CONDUCTED EMISSIONS**

**Applicable Standard**

FCC§15.207

**EUT Setup**

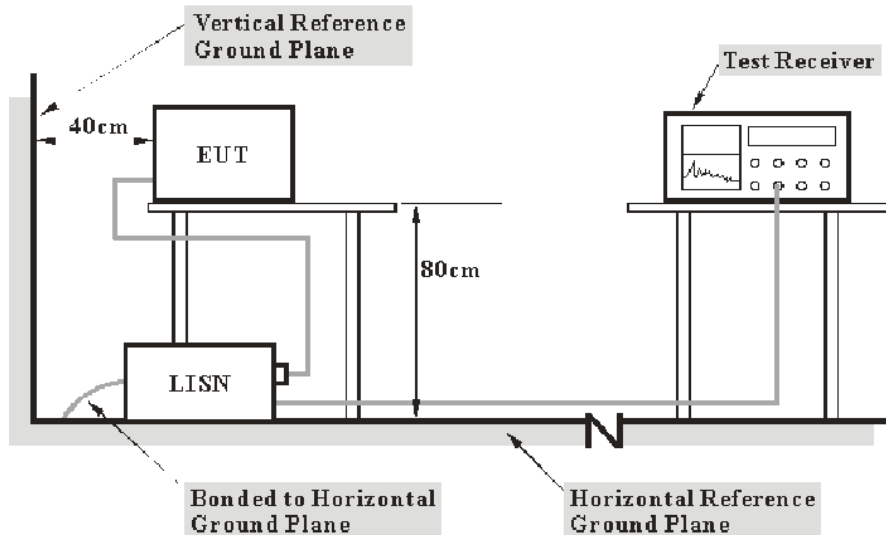

- Note: 1. Support units were connected to second LISN.  
 2. Both of LISNs (AMN) 80 cm from EUT and at the least 80 cm from other units and other metal planes support units.

The setup of EUT is according with per ANSI C63.10-2013 measurement procedure. The specification used was with the FCC Part 15.207 limits.

The spacing between the peripherals was 10 cm.

**EMI Test Receiver Setup**

The EMI test receiver was set to investigate the spectrum from 150 kHz to 30 MHz.

During the conducted emission test, the EMI test receiver was set with the following configurations:

Frequency Range	IF B/W
150 kHz – 30 MHz	9 kHz

**Test Procedure**

During the conducted emission test, the adapter was connected to the outlet of the LISN.

Maximizing procedure was performed on the six (6) highest emissions of the EUT.

All final data was recorded in the Quasi-peak and average detection mode.

## Corrected Factor & Margin Calculation

The Corrected factor is calculated by adding LISN VDF (Voltage Division Factor), Cable Loss and Transient Limiter Attenuation. The basic equation is as follows:

$$\text{Correction Factor} = \text{LISN VDF} + \text{Cable Loss} + \text{Transient Limiter Attenuation}$$

The “**Margin**” column of the following data tables indicates the degree of compliance with the applicable limit. For example, a margin of 7 dB means the emission is 7 dB below the limit. The equation for margin calculation is as follows:

$$\text{Margin} = \text{Limit} - \text{Corrected Amplitude}$$

## Test Results Summary

According to the recorded data in following table, the EUT complied with the FCC Part 15.207.

Refer to CISPR16-4-2:2011 and CISPR 16-4-1:2009, the measured level complies with the limit if

$$L_m + U_{(L_m)} \leq L_{\text{lim}} + U_{\text{cispr}}$$

In BACL,  $U_{(L_m)}$  is less than  $U_{\text{cispr}}$ , if  $L_m$  is less than  $L_{\text{lim}}$ , it implies that the EUT complies with the limit.

## Test Data

### Environmental Conditions

<b>Temperature:</b>	25 °C
<b>Relative Humidity:</b>	48%
<b>ATM Pressure:</b>	101.0 kPa

*The testing was performed by Layne Li on 2017-01-05.*

EUT operation mode: Transmitting

**AC 120V/60 Hz, Line**

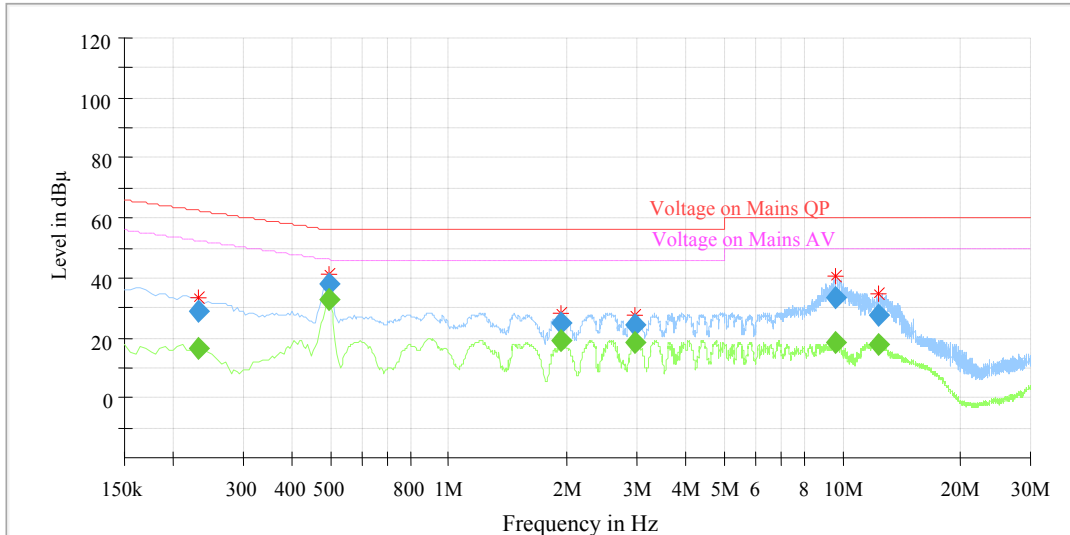

Frequency (MHz)	QuasiPeak (dBµV)	Average (dB µ V)	Bandwidth (kHz)	Line	Corr. (dB)	Margin (dB)	Limit (dBµV)	Comment
0.230000	---	16.63	9.000	L1	10.3	35.82	52.45	Compliance
0.230000	28.97	---	9.000	L1	10.3	33.48	62.45	Compliance
0.495000	---	32.66	9.000	L1	10.3	13.42	46.08	Compliance
0.495000	37.80	---	9.000	L1	10.3	18.28	56.08	Compliance
1.930000	---	19.24	9.000	L1	10.4	26.76	46.00	Compliance
1.930000	24.68	---	9.000	L1	10.4	31.32	56.00	Compliance
2.980000	---	18.12	9.000	L1	10.4	27.88	46.00	Compliance
2.980000	24.54	---	9.000	L1	10.4	31.46	56.00	Compliance
9.615000	---	18.20	9.000	L1	10.5	31.80	50.00	Compliance
9.615000	33.17	---	9.000	L1	10.5	26.83	60.00	Compliance
12.280000	---	17.71	9.000	L1	10.4	32.29	50.00	Compliance
12.280000	27.31	---	9.000	L1	10.4	32.69	60.00	Compliance

**AC 120V/60 Hz, Neutral**

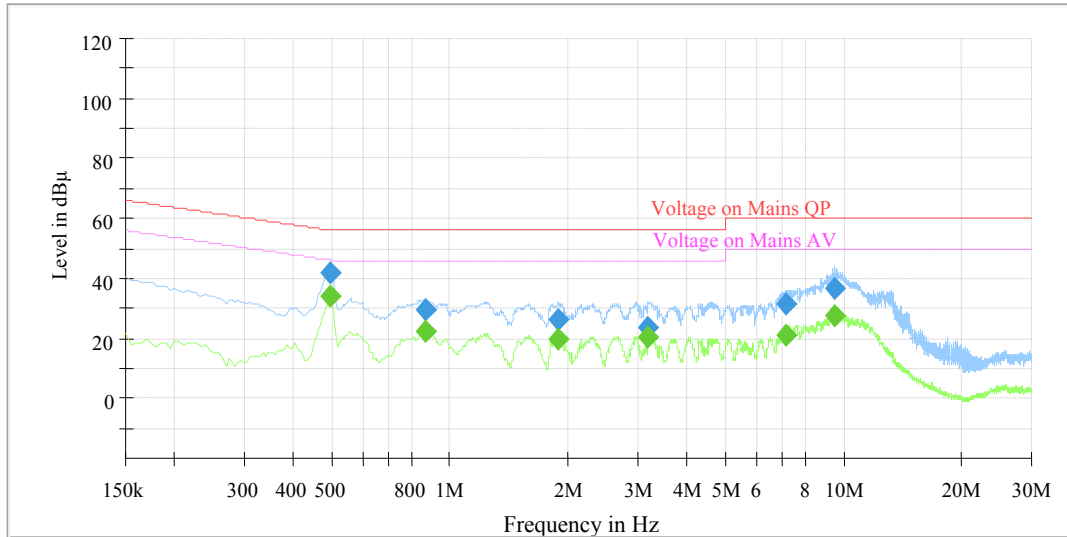

Frequency (MHz)	QuasiPeak (dBµV)	Average (dB µ V)	Bandwidth (kHz)	Line	Corr. (dB)	Margin (dB)	Limit (dBµV)	Comment
0.495000	---	34.01	9.000	N	10.3	12.07	46.08	Compliance
0.495000	41.60	---	9.000	N	10.3	14.48	56.08	Compliance
0.865000	---	22.51	9.000	N	10.3	23.49	46.00	Compliance
0.865000	29.19	---	9.000	N	10.3	26.81	56.00	Compliance
1.880000	---	20.01	9.000	N	10.4	25.99	46.00	Compliance
1.880000	25.97	---	9.000	N	10.4	30.03	56.00	Compliance
3.195000	---	20.39	9.000	N	10.5	25.61	46.00	Compliance
3.195000	23.85	---	9.000	N	10.5	32.15	56.00	Compliance
7.130000	---	21.09	9.000	N	10.6	28.91	50.00	Compliance
7.130000	31.71	---	9.000	N	10.6	28.29	60.00	Compliance
9.530000	---	27.61	9.000	N	10.5	22.39	50.00	Compliance
9.530000	36.53	---	9.000	N	10.5	23.47	60.00	Compliance

Note:

- 1) Corrected Amplitude = Reading + Correction Factor
- 2) Correction Factor = LISN VDF + Cable Loss + Transient Limiter Attenuation
- 3) Margin = Limit – Corrected Amplitude



## FCC §15.209, §15.205 & §15.247(d) - SPURIOUS EMISSIONS

### Applicable Standard

FCC §15.247 (d); §15.209; §15.205;

### EUT Setup

#### Below 1 GHz:

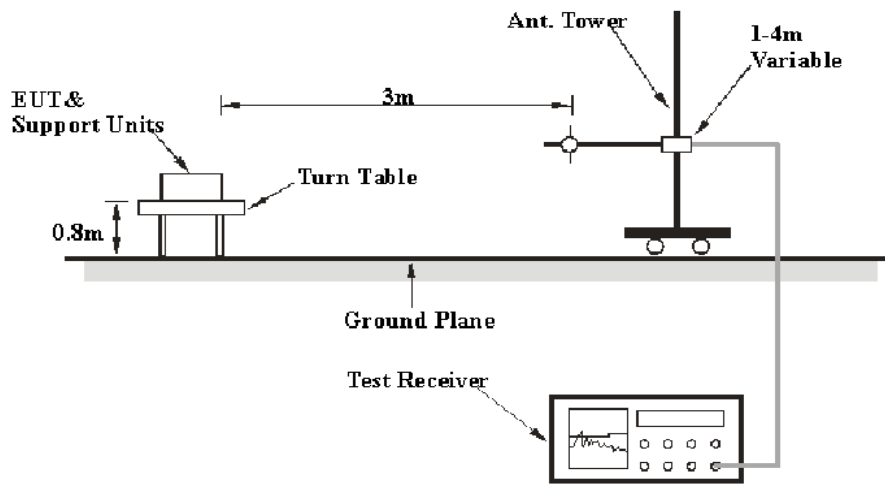

#### Above 1GHz:

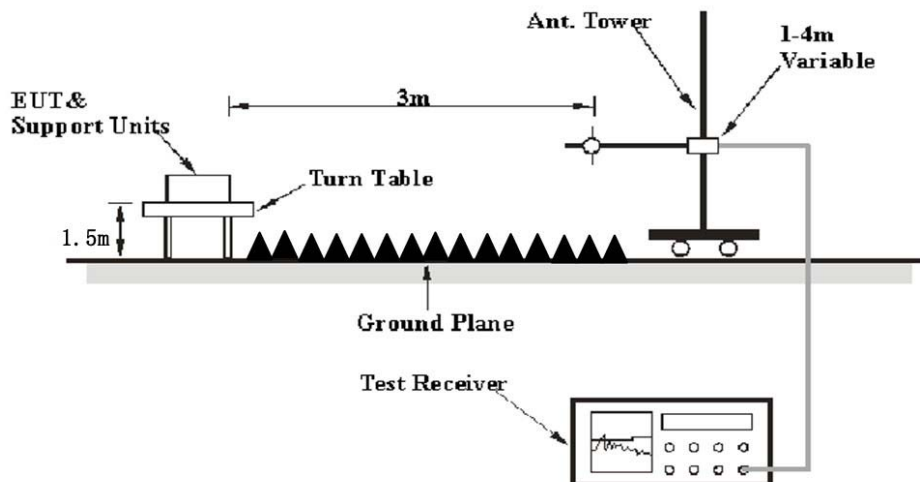

The radiated emission tests were performed in the 3 meters test site, using the setup accordance with the ANSI C63.10-2013. The specification used was the FCC 15.209, and FCC 15.247 limits.

## EMI Test Receiver & Spectrum Analyzer Setup

The system was investigated from 30 MHz to 25 GHz.

During the radiated emission test, the EMI test receiver & Spectrum Analyzer Setup were set with the following configurations:

Frequency Range	RBW	Video B/W	IF B/W	Detector
30 MHz – 1000 MHz	100 kHz	300 kHz	120 kHz	QP
Above 1 GHz	1MHz	3 MHz	/	PK
	1MHz	10 Hz <sup>Note 1</sup>	/	Ave.
	1MHz	> 1/T <sup>Note 2</sup>	/	Ave.

Note 1: when duty cycle is no less than 98%

Note 2: when duty cycle is less than 98%

## Test Procedure

Maximizing procedure was performed on the highest emissions to ensure that the EUT complied with all installation combinations.

Data was recorded in Quasi-peak detection mode for frequency range of 30 MHz-1 GHz, peak and Average detection modes for frequencies above 1 GHz.

## Corrected Amplitude & Margin Calculation

The Corrected Amplitude is calculated by adding the Antenna Factor and Cable Loss, and subtracting the Amplifier Gain from the Meter Reading. The basic equation is as follows:

$$\text{Corrected Amplitude} = \text{Meter Reading} + \text{Antenna Factor} + \text{Cable Loss} - \text{Amplifier Gain}$$

The “**Margin**” column of the following data tables indicates the degree of compliance with the applicable limit. For example, a margin of 7dB means the emission is 7dB below the limit. The equation for margin calculation is as follows:

$$\text{Margin} = \text{Limit} - \text{Corrected Amplitude}$$

## Test Results Summary

According to the recorded data in following table, the EUT complied with the FCC Title 47, Part 15, Subpart C, section 15.205, 15.209 and 15.247.

Refer to CISPR16-4-2:2011 and CISPR 16-4-1:2009, the measured level complies with the limit if

$$L_m + U_{(L_m)} \leq L_{lim} + U_{cispr}$$

In BACL,  $U_{(L_m)}$  is less than  $U_{cispr}$ , if  $L_m$  is less than  $L_{lim}$ , it implies that the EUT complies with the limit.

**Test Data**

**Environmental Conditions**

<b>Temperature:</b>	25 °C
<b>Relative Humidity:</b>	48%
<b>ATM Pressure:</b>	101.0 kPa

*The testing was performed by Layne Li on 2017-02-10.*

*EUT operation mode: Transmitting*

**30 MHz- 25 GHz:**

Frequency (MHz)	Receiver		Turntable Degree	Rx Antenna		Corrected Factor (dB)	Corrected Amplitude (dBµV/m)	FCC Part 15.247/205/209	
	Reading (dBµV)	Detector (PK/QP/Ave.)		Height (m)	Polar (H/V)			Limit (dBµV/m)	Margin (dB)
<b>Low Channel (2402 MHz)</b>									
274.1	43.93	QP	159	1.1	H	-11.97	31.96	46	14.04
2402.00	101.54	Ave.	315	1.3	H	-6.19	95.35	/	/
2402.00	92.72	PK	315	1.3	H	-6.19	86.53	/	/
2402.00	98.51	Ave.	87	1.4	V	-6.19	92.32	/	/
2402.00	88.24	PK	87	1.4	V	-6.19	82.05	/	/
2355.49	66.81	PK	79	2.3	V	-6.19	60.62	74	13.38
2355.49	49.64	Ave.	79	2.3	V	-6.19	43.45	54	10.55
2360.42	64.04	PK	257	2.2	V	-6.19	57.85	74	16.15
2360.42	52.37	Ave.	257	2.2	V	-6.19	46.18	54	7.82
2485.37	62.79	PK	29	1.1	V	-5.97	56.82	74	17.18
2485.37	52.14	Ave.	29	1.1	V	-5.97	46.17	54	7.83
4804.00	46.97	PK	190	1.0	V	1.6	48.57	74	25.43
4804.00	40.16	Ave.	190	1.0	V	1.6	41.76	54	12.24
7206.00	47.95	PK	78	2.4	H	7.54	55.49	74	18.51
7206.00	36.93	Ave.	78	2.4	H	7.54	44.47	54	9.53
<b>Middle Channel (2440 MHz)</b>									
274.1	44.14	QP	159	1.1	H	-11.97	32.17	46	13.83
2440.00	99.34	Ave.	180	1.1	H	-6.19	93.15	/	/
2440.00	91.62	PK	180	1.1	H	-6.19	85.43	/	/
2440.00	97.53	Ave.	295	1.9	V	-6.19	91.34	/	/
2440.00	88.55	PK	295	1.9	V	-6.19	82.36	/	/
2347.40	65.78	PK	171	2.1	V	-6.42	59.36	74	14.64
2347.40	48.54	Ave.	171	2.1	V	-6.42	42.12	54	11.88
2487.01	65.35	PK	222	1.3	V	-5.97	59.38	74	14.62
2487.01	50.8	Ave.	222	1.3	V	-5.97	44.83	54	9.17
2488.15	64.38	PK	21	2.4	V	-5.97	58.41	74	15.59
2488.15	48.87	Ave.	21	2.4	V	-5.97	42.90	54	11.10
4880.00	45.34	PK	228	2.1	V	1.83	47.17	74	26.83
4880.00	39.95	Ave.	228	2.1	V	1.83	41.78	54	12.22
7320.00	48.92	PK	72	2.2	H	7.54	56.46	74	17.54
7320.00	38.6	Ave.	72	2.2	H	7.54	46.14	54	7.86

Frequency (MHz)	Receiver		Turntable Degree	Rx Antenna		Corrected Factor (dB)	Corrected Amplitude (dBµV/m)	FCC Part 15.247/205/209	
	Reading (dBµV)	Detector (PK/QP/Ave.)		Height (m)	Polar (H/V)			Limit (dBµV/m)	Margin (dB)
<b>High Channel (2480 MHz)</b>									
274.1	43.99	QP	159	1.1	H	-11.97	32.02	46	13.98
2480.00	98.36	Ave.	44	1.1	H	-5.97	92.39	/	/
2480.00	90.43	PK	44	1.1	H	-5.97	84.46	/	/
2480.00	97.61	Ave.	152	1.1	V	-5.97	91.64	/	/
2480.00	87.93	PK	152	1.1	V	-5.97	81.96	/	/
2346.30	63.33	PK	117	1.2	V	-6.42	56.91	74	17.09
2346.30	51.58	Ave.	117	1.2	V	-6.42	45.16	54	8.84
2486.01	65.43	PK	226	1.2	V	-5.97	59.46	74	14.54
2486.01	49.2	Ave.	226	1.2	V	-5.97	43.23	54	10.77
2484.57	64.14	PK	261	1.8	V	-5.97	58.17	74	15.83
2484.57	52.14	Ave.	261	1.8	V	-5.97	46.17	54	7.83
4960.00	49.53	PK	84	1.7	V	2.06	51.59	74	22.41
4960.00	42.79	Ave.	84	1.7	V	2.06	44.85	54	9.15
7440.00	48.75	PK	106	2.5	H	7.54	56.29	74	17.71
7440.00	38.59	Ave.	106	2.5	H	7.54	46.13	54	7.87

**Note:**

Corrected Factor = Antenna factor (RX) + Cable Loss – Amplifier Factor

Corrected Amplitude = Corrected Factor + Reading

Margin = Limit - Corrected. Amplitude

The other spurious emission which is 20dB to the limit was not recorded.

**FCC §15.247(a) (2) – 6 dB EMISSION BANDWIDTH**

**Applicable Standard**

Systems using digital modulation techniques may operate in the 902–928 MHz, 2400–2483.5 MHz, and 5725–5850 MHz bands. The minimum 6 dB bandwidth shall be at least 500 kHz.

**Test Procedure**

1. Check the calibration of the measuring instrument using either an internal calibrator or a known signal from an external generator.
2. Position the EUT without connection to measurement instrument. Turn on the EUT and connect it to measurement instrument. Then set it to any one convenient frequency within its operating range. Set a reference level on the measuring instrument equal to the highest peak value.
3. Measure the frequency difference of two frequencies that were attenuated 6 dB from the reference level. Record the frequency difference as the emission bandwidth.
4. Repeat above procedures until all frequencies measured were complete.

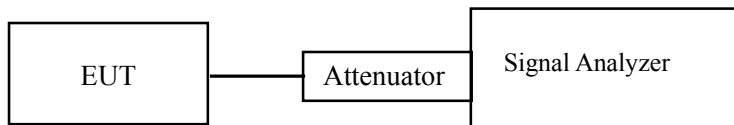

**Test Data**

**Environmental Conditions**

<b>Temperature:</b>	25 °C
<b>Relative Humidity:</b>	50 %
<b>ATM Pressure:</b>	101 kPa

*The testing was performed by Echo Wu on 2017-01-09.*

*Test Result: Compliance.*

*EUT operation mode: Transmitting*

Please refer to following table and plots.

Channel	Frequency (MHz)	6 dB Emission Bandwidth (MHz)	Limit (kHz)
Low	2402	0.713	≥500
Middle	2440	0.721	≥500
High	2480	0.729	≥500

**Low Channel**

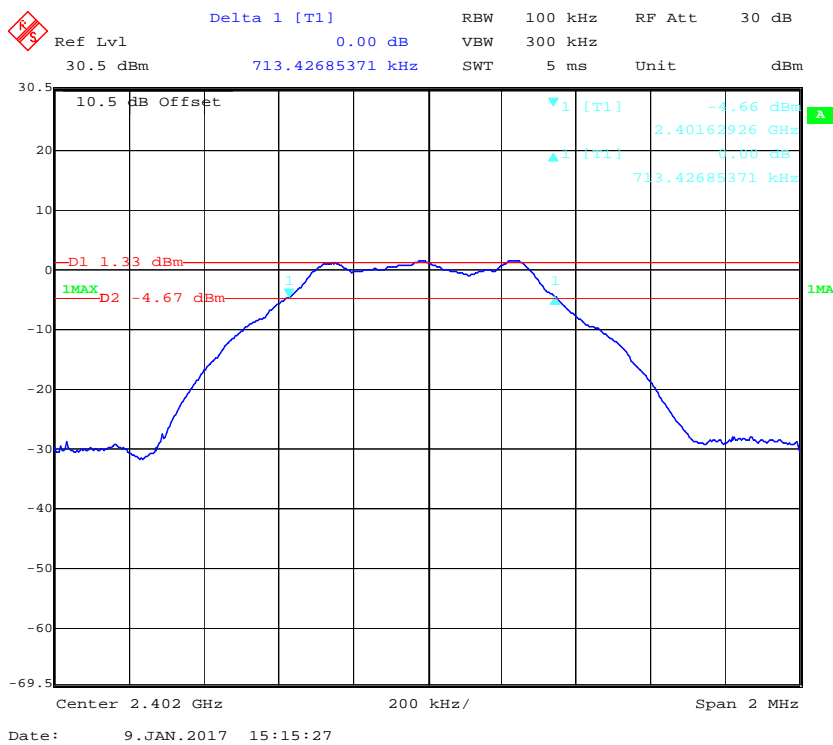

### Middle Channel

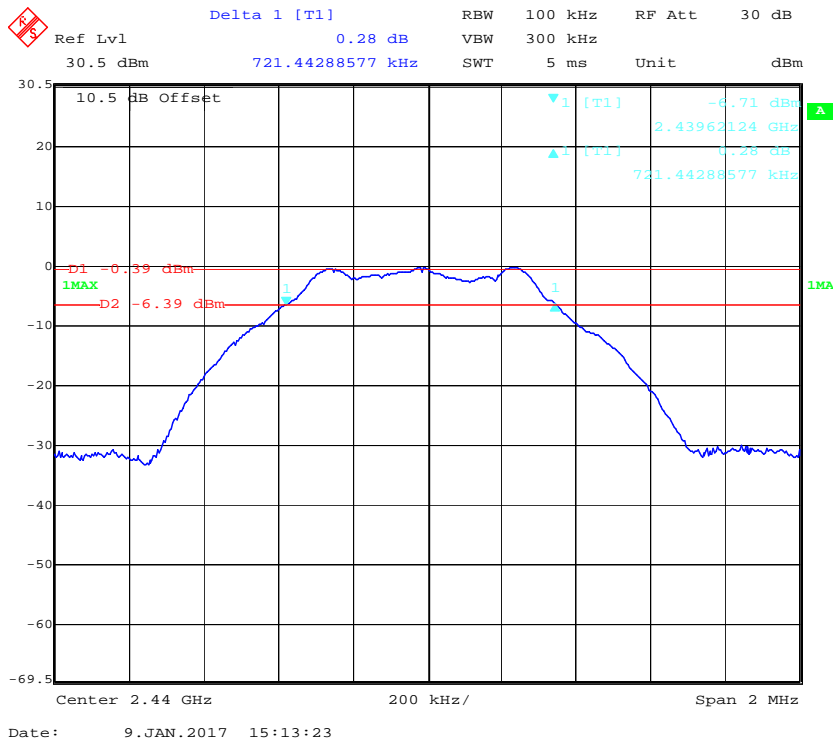

### High Channel

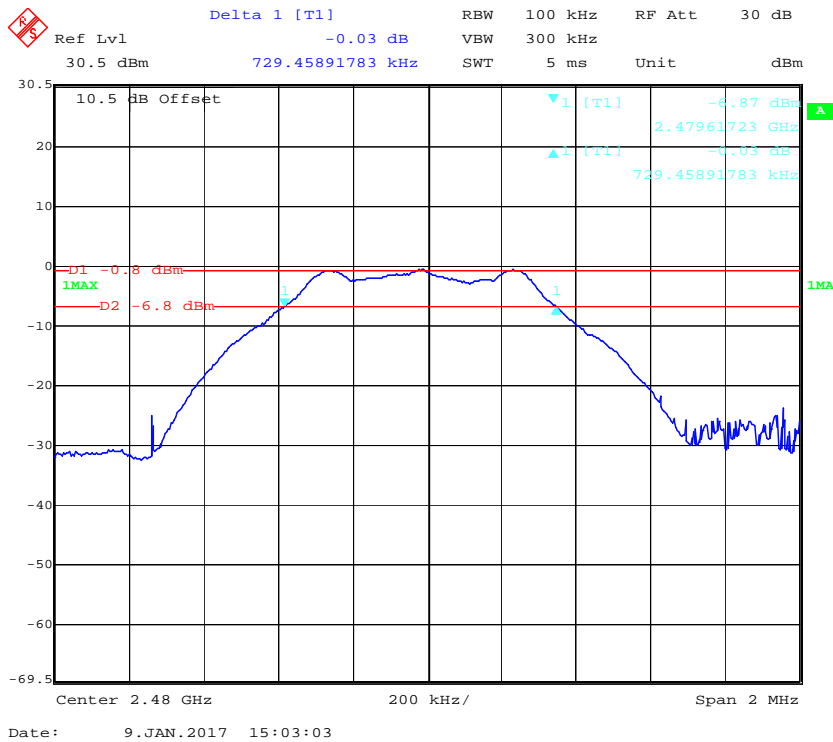



## FCC §15.247(b) (3) - MAXIMUM CONDUCTED OUTPUT POWER

### Applicable Standard

According to FCC §15.247(b) (3), for systems using digital modulation in the 902-928 MHz, 2400-2483.5 MHz, and 5725-5850 MHz bands: 1 Watt. As an alternative to a peak power measurement, compliance with the one Watt limit can be based on a measurement of the maximum conducted output power. Maximum Conducted Output Power is defined as the total transmit power delivered to all antennas and antenna elements averaged across all symbols in the signaling alphabet when the transmitter is operating at its maximum power control level. Power must be summed across all antennas and antenna elements. The average must not include any time intervals during which the transmitter is off or is transmitting at a reduced power level. If multiple modes of operation are possible (e.g., alternative modulation methods), the maximum conducted output power is the highest total transmit power occurring in any mode.

### Test Procedure

1. Place the EUT on a bench and set it in transmitting mode.
2. Remove the antenna from the EUT and then connect a low loss RF cable from the antenna port to one test equipment.
3. Add a correction factor to the display.

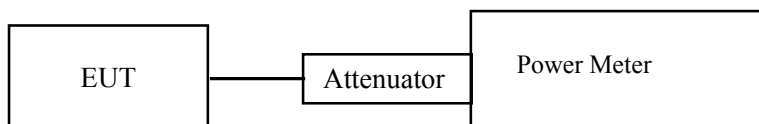

### Test Data

#### Environmental Conditions

<b>Temperature:</b>	25 °C
<b>Relative Humidity:</b>	50 %
<b>ATM Pressure:</b>	101.0 kPa

*The testing was performed by Echo Wu on 2016-01-09.*

*Test Result: Compliance.*

*EUT operation mode: Transmitting*

Please refer to following table and plots.

Channel	Frequency (MHz)	Max Peak Output Power (dBm)	Limit (dBm)	Result
Low	2402	1.41	30	Pass
Middle	2440	-0.26	30	Pass
High	2480	-0.91	30	Pass

**FCC §15.247(d) – 100 kHz BANDWIDTH OF FREQUENCY BAND EDGE**

**Applicable Standard**

In any 100 kHz bandwidth outside the frequency band in which the spread spectrum or digitally modulated intentional radiator is operating, the radio frequency power that is produced by the intentional radiator shall be at least 20 dB below that in the 100 kHz bandwidth within the band that contains the highest level of the desired power, based on either an RF conducted or a radiated measurement, provided the transmitter demonstrates compliance with the peak conducted power limits. If the transmitter complies with the conducted power limits based on the use of RMS averaging over a time interval, as permitted under paragraph (b)(3) of this section, the attenuation required under this paragraph shall be 30 dB instead of 20 dB. Attenuation below the general limits specified in §15.209(a) is not required. In addition, radiated emissions which fall in the restricted bands, as defined in §15.205(a), must also comply with the radiated emission limits specified in §15.209(a) (see §15.205(c)).

**Test Procedure**

1. Check the calibration of the measuring instrument using either an internal calibrator or a known signal from an external generator.
2. Position the EUT without connection to measurement instrument. Turn on the EUT and connect its antenna terminal to measurement instrument via a low loss cable. Then set it to any one measured frequency within its operating range, and make sure the instrument is operated in its linear range.
3. Set RBW to 100 kHz and VBW of spectrum analyzer to 300 kHz with a convenient frequency span including 100 kHz bandwidth from band edge.
4. Measure the highest amplitude appearing on spectral display and set it as a reference level. Plot the graph with marking the highest point and edge frequency.
5. Repeat above procedures until all measured frequencies were complete.

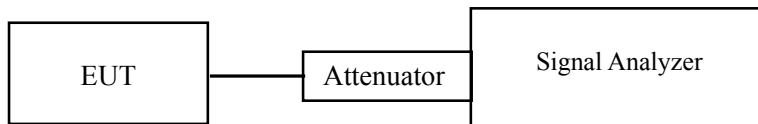

**Test Data**

**Environmental Conditions**

<b>Temperature:</b>	25 °C
<b>Relative Humidity:</b>	50 %
<b>ATM Pressure:</b>	101.0 kPa

*The testing was performed by Echo Wu on 2017-01-09*

*Test Result: Compliance.*

*EUT operation mode: Transmitting*

Please refer to the following plots

**Band Edge, Left Side**

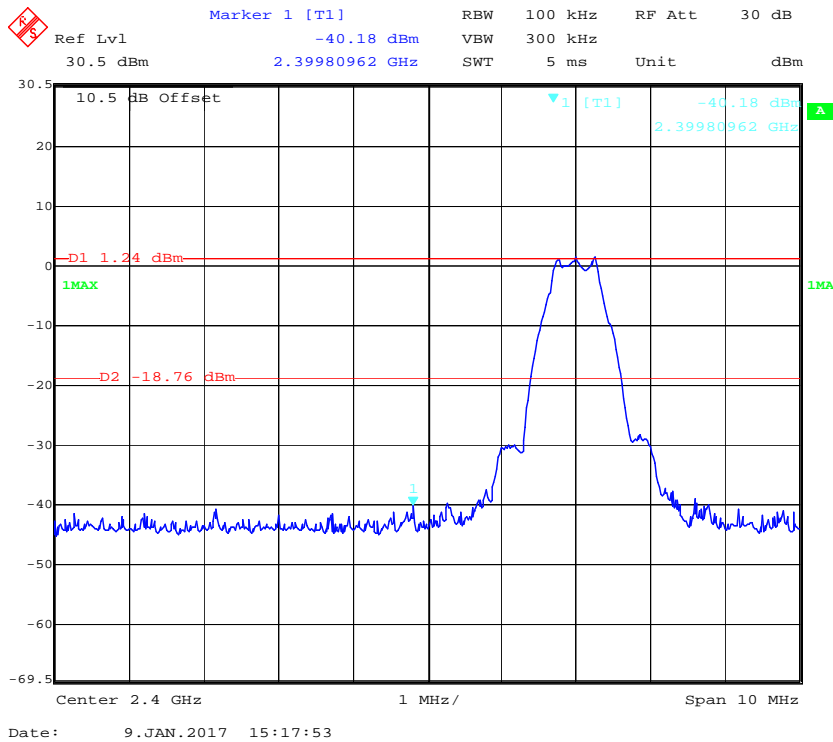

**Band Edge, Right Side**

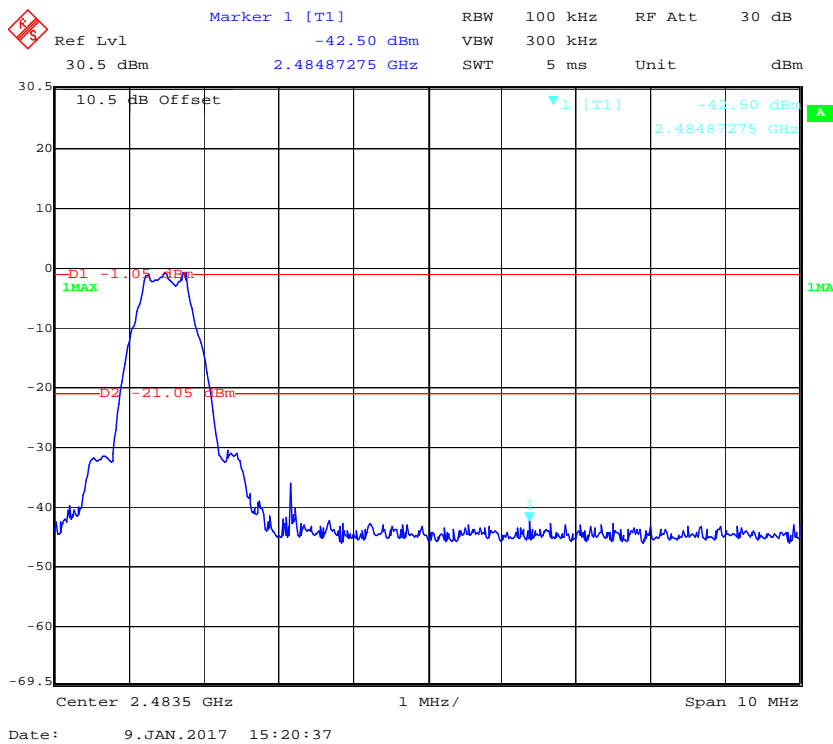

**FCC §15.247(e) - POWER SPECTRAL DENSITY**

**Applicable Standard**

For digitally modulated systems, the power spectral density conducted from the intentional radiator to the antenna shall not be greater than 8 dBm in any 3 kHz band during any time interval of continuous transmission. This power spectral density shall be determined in accordance with the provisions of paragraph (b) of this section. The same method of determining the conducted output power shall be used to determine the power spectral density.

**Test Procedure**

1. Use this procedure when the maximum peak conducted output power in the fundamental emission is used to demonstrate compliance.
2. Set the RBW to:  $3\text{kHz} \leq \text{RBW} \leq 100\text{ kHz}$ .
3. Set the VBW  $\geq 3 \times \text{RBW}$ .
4. Set the span to 1.5 times the DTS bandwidth.
5. Detector = peak.
6. Sweep time = auto couple.
7. Trace mode = max hold.
8. Allow trace to fully stabilize.
9. Use the peak marker function to determine the maximum amplitude level within the RBW.
10. If measured value exceeds limit, reduce RBW (no less than 3 kHz) and repeat.

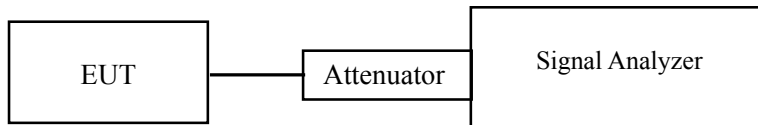

**Test Data**

**Environmental Conditions**

<b>Temperature:</b>	25 °C
<b>Relative Humidity:</b>	50 %
<b>ATM Pressure:</b>	101.0 kPa

*The testing was performed by Echo Wu on 2017-01-09*

*Test Result: Compliance.*

*EUT operation mode: Transmitting*

Please refer to following table and plots.

Channel	Frequency (MHz)	PSD (dBm/3kHz)	Limit (dBm/3kHz)
Low	2402	-13.83	≤8
Middle	2440	-15.55	≤8
High	2480	-16.17	≤8

**Power Spectral Density, Low Channel**

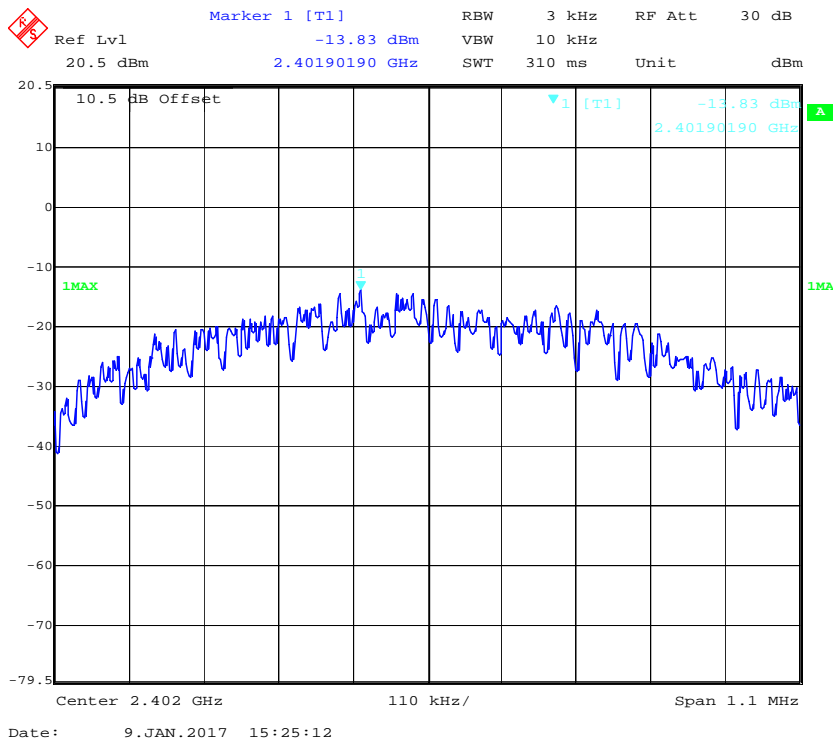

**Power Spectral Density, Middle Channel**

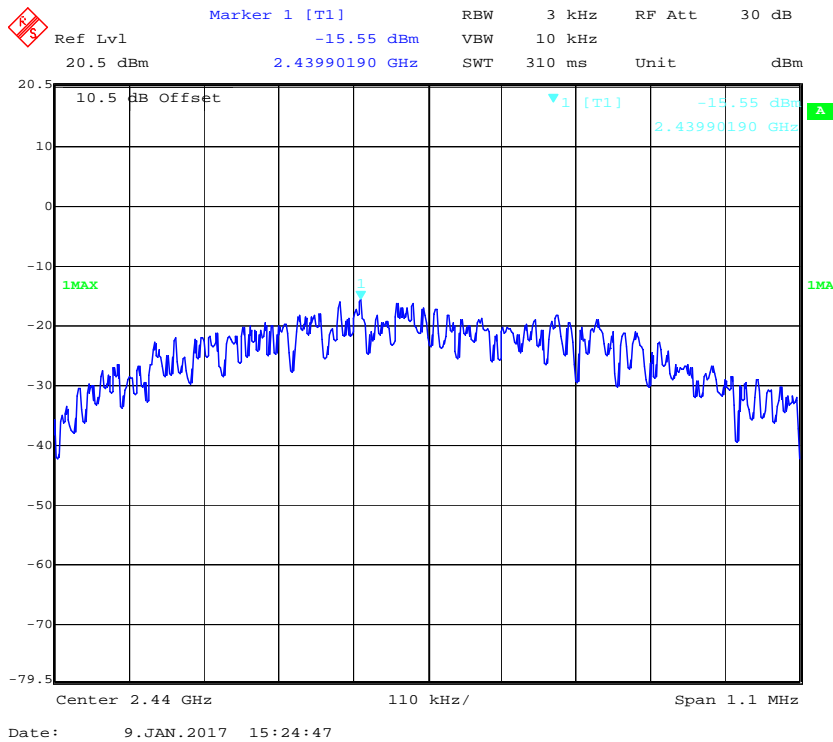

**Power Spectral Density, High Channel**

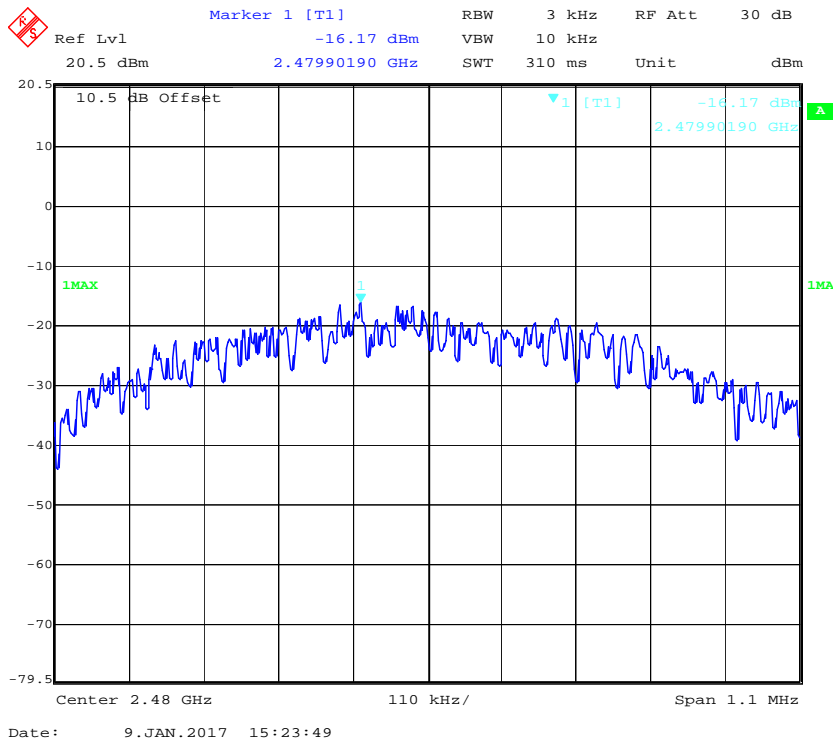

\*\*\*\*\* END OF REPORT \*\*\*\*\*