



**RTX Consumer Products Hong Kong Ltd.**

Application  
For  
Permissive Change Class II

Unlicensed Personal Communication Service Devices  
(Handset)

**FCC ID: T7HCT8010**

**Test Report Number: HK08051011-1**

**Issue Date: June 4, 2008**

TL/ ac

- The test report only allows to be revised within three years from its original issued date unless further standard or the requirement was noticed.
- This report is for the exclusive use of Intertek's Client and is provided pursuant to the agreement between Intertek and its Client. Intertek's responsibility and liability are limited to the terms and conditions of the agreement. Intertek assumes no liability to any party, other than to the Client in accordance with the agreement, for any loss, expense or damage occasioned by the use of this report. Only the Client is authorized to permit copying or distribution of this report and then only in its entirety. Any use of the Intertek name or one of its marks for the sale or advertisement of the tested material, product or service must first be approved in writing by Intertek. The observations and test results in this report are relevant only to the sample tested. This report by itself does not imply that the material, product, or service is or has ever been under an Intertek certification program.

**Intertek Testing Services Hong Kong Ltd.**

2/F., Garment Centre, 576 Castle Peak Road, Kowloon, Hong Kong.  
Tel: (852) 2173 8888 Fax: (852) 2785 5487 Website: [www.hk.intertek-etlsemko.com](http://www.hk.intertek-etlsemko.com)

**LIST OF EXHIBITS**

*INTRODUCTION*

<i>EXHIBIT 1:</i>	Summary of Tests
<i>EXHIBIT 2:</i>	General Description
<i>EXHIBIT 3:</i>	System Test Configuration
<i>EXHIBIT 4:</i>	Measurement Results
<i>EXHIBIT 5:</i>	Equipment Photographs
<i>EXHIBIT 6:</i>	Technical Specifications
<i>EXHIBIT 7:</i>	Letter of Agency
<i>EXHIBIT 8:</i>	Confidentiality Request



---

# INTERTEK TESTING SERVICES

---

## Table of Contents

<b>1.0 Summary of Test Results</b> .....	6
<b>2.0 General Description</b> .....	8
2.1 Product Description .....	8
2.2 Purpose of Application.....	8
2.3 Test Methodology.....	9
2.4 Test Facility .....	9
<b>3.0 System Test Configuration</b> .....	11
3.1 Justification .....	11
3.2 Conducted Emission Test Configuration .....	12
3.3 EUT Exercising Software.....	12
3.4 Details of EUT and Description of Peripherals .....	13
3.5 Measurement Uncertainty .....	14
3.6 Equipment Modification .....	14
<b>4.0 Measurement Results</b> .....	16
4.1 Emission Bandwidth .....	16
4.2 Peak Transmit Power .....	17
4.3 Power Spectral Density .....	18
4.4 Unwanted Emission Inside the Sub-Band .....	19
4.5 Emissions Outside the Sub-Band .....	20
4.5.1 Radiated Emissions Configuration Photographs .....	21
4.5.2 Radiated Emissions Data .....	22
4.5.3 Field Strength Calculation.....	26
4.5.4 Average Factor Calculation and Transmitter On Time Measurements .....	27
4.6 AC Power Lines Conducted Emissions from Transmitter portion of EUT .....	28
4.6.1 AC Power Lines Conducted Emissions Configuration Photographs.....	29
4.6.2 AC Power Lines Conducted Emissions Data.....	30
4.7 Radio Frequency Radiation Exposure.....	31
<b>5.0 Equipment Photographs</b> .....	33
<b>6.0 Technical Specifications</b> .....	35
<b>7.0 Letter of Agency</b> .....	37
<b>8.0 Confidentiality Request</b> .....	39

## INTERTEK TESTING SERVICES

---

### List of Attached Files

<b>Exhibit Type</b>	<b>File Description</b>	<b>Filename</b>
Cover Letter	Purpose of Change	product change.pdf
Test Report	Test Report	report.pdf
Test Report	Emission Bandwidth and Test Frequency Plots	26bw.pdf
Test Report	Peak Transmit Power Plots	peaktp.pdf
Test Report	Power Spectral Density Plots	psd.pdf
Test Report	Unwanted Emission Inside Sub-Band Plots	inband.pdf
Test Report	AC Lines Conducted Emission Data	conduct.pdf
Test Setup Photos	Radiated Emission Test Configuration	config photos.pdf
Test Setup Photos	AC Lines Conducted Emission Test Configuration	
RF Exposure Info	SAR Evaluation Report	SAR report 1 of 2.pdf SAR report 2 of 2.pdf
External Photos	External Photo	external photos.pdf
Internal Photos	Internal Photo	internal photos.pdf
Schematics	Circuit Diagram	circuit.pdf
Cover Letter	Letter of Agency	letter of agency.pdf
Cover Letter	Confidentiality Request	request.pdf

**EXHIBIT 1  
SUMMARY OF TEST RESULTS**

# INTERTEK TESTING SERVICES

## 1.0 Summary of Test Results

RTX Consumer Products Hong Kong Ltd.

Model: CT8010 DECT Handset - INT, CT8010 DECT Handset - NA,  
CT8010 DECT Handset - LATAM, G355 DECT Handset - NEC,  
G355 DECT Handset - NEC NA, G355 DECT Handset - LATAM,  
NEC G355 DECT Handset, G355 DECT Handset - INT,  
G355 DECT Handset - NA, G355 DECT Handset - LATAM

FCC ID: T7HCT8010

Technical Requirements				
Test Items	FCC Part 15 Section	Test Procedure ANSI C63.17 / ANSI C63.4 *	Results	Details see section
Emission Bandwidth	15.323(a)	6.1.3	Pass	4.1
Peak Transmit Power	15.319(c)	6.1.2	Pass	4.2
Power Spectral Density	15.319(d)	6.1.5	Pass	4.3
Unwanted Emission Inside the Sub-Band	15.323(d)	6.1.6.1	Pass	4.4
Emissions Outside the Sub-Band	15.323(d)	6.1.6.2	Pass	4.5
AC Power Lines Conducted Emissions from Transmitter Portion of EUT	15.315	7 *	Pass	4.6
Radio Frequency Radiation Exposure	15.319(i)	---	Pass	4.9

**Test Engineer:**



Ken Sit  
Supervisor

Date: June 4, 2008

**Approved By:**



Leung Wai Leung, Tommy  
Senior Manager

Date: June 4, 2008

**EXHIBIT 2  
GENERAL DESCRIPTION**



# INTERTEK TESTING SERVICES

---

## 2.0 General Description

### 2.1 Product Description

The CT8010 DECT Handset - INT is a 1.9GHz Digital Modulation Cordless Phone with Caller ID and Speakerphone - Handset. It operates at frequency range of 1921.536MHz to 1928.448MHz with 5 channels (1921.536MHz, 1923.264MHz, 1924.992MHz, 1926.720MHz and 1928.448MHz). The handset is powered by a "Li-ion" type rechargeable battery (3.7V 650mAh).

The antenna used in handset is integral, and the test sample is a prototype.

The Model: CT8010 DECT Handset - NA, CT8010 DECT Handset - LATAM, G355 DECT Handset - NEC, G355 DECT Handset - NEC NA, G355 DECT Handset - LATAM, NEC G355 DECT Handset, G355 DECT Handset - INT, G355 DECT Handset - NA, and G355 DECT Handset - LATAM are the same as the Model: CT8010 DECT Handset - INT in hardware aspect except different cosmetics. The difference in model number serves as marketing strategy.

Connection between the base unit and the telephone network is accomplished through the use of USOC RJ11C in the 2-wire loop calling central office line.

### 2.2 Purpose of Application

The purpose of change is saved as filename: product change.pdf

For the handset of Model: CT8010 DECT Handset - INT, antenna, enclosure, PCB layout, and LBT algorithm are the same as the previously granted Model: CT8010 DECT Handset - INT. For optimization of RF performance and spurious emission level, component values for DECT 6.0 module are changed, but there is no change to the basic frequency determining and stabilizing circuitry (including clock or data rates), frequency multiplication stages, basic modulator circuit and maximum output power.

This is an application for Certification of a PUE - Part 15 Unlicensed PCS Portable TX Held to Ear. A verification report has been prepared for the digital portion. The device is also subject to Part 68 Registration.

## INTERTEK TESTING SERVICES

---

### 2.3 Test Methodology

The radiated emission measurements for unintentional radiator (if any) and AC power line-conducted emission measurements were performed according to the test procedures specified in ANSI C63.4 (2003). The radiated emission measurements for intentional radiator contained in UPCS device, and antenna conducted measurements were performed according to the test procedures specified in ANSI C63.17 (2006). All radiated measurements were performed in Open Area Test Sites. Preliminary scans were performed in the Open Area Test Sites only to determine worst case modes. All radiated tests were performed at an antenna to EUT distance of 3 meters, unless stated otherwise in the "Justification Section" of this Application. All other measurements were made in accordance with the procedures in 47 CFR Part 2.

### 2.4 Test Facility

The open area test site facility used to collect the emission data is located at Garment Centre, 576 Castle Peak Road, Kowloon, Hong Kong. This test facility and site measurement data have been fully placed on file with the FCC.

**EXHIBIT 3  
SYSTEM TEST CONFIGURATION**

## INTERTEK TESTING SERVICES

---

### 3.0 System Test Configuration

#### 3.1 Justification

For emissions testing, the equipment under test (EUT) was setup to transmit continuously in burst mode with pseudo-random data to simplify the measurement methodology. Care was taken to ensure proper power supply voltages during testing. During testing, all cables (if any) were manipulated to produce worst-case emissions. The handset (if any) was powered by a fully charged battery.

For the measurements, the EUT was attached to a plastic stand if necessary and placed on the wooden turntable. If the base unit attached to peripherals, they were connected and operational (as typical as possible).

The signal was maximized through rotation and placement in the three orthogonal axes. The antenna height and polarization were varied during the search for maximum signal level. The antenna height was varied from 1 to 4 meters. Detector function was in peak mode. Radiated emissions are taken at three meters unless the signal level was too low for measurement at that distance. If necessary, a pre-amplifier was used and/or the test was conducted at a closer distance.

The spectrum analyzer resolution bandwidth was approximately 1% of the EUT emission bandwidth, unless otherwise specified.

Radiated emission measurements were performed from the lowest radio frequency signal generated in the device which is greater than 9 kHz to the tenth harmonic of the highest fundamental frequency or to 40 GHz, whichever is lower.

# INTERTEK TESTING SERVICES

---

## 3.2 Conducted Emission Test Configuration

The setup and equipment setting were made in accordance with ANSI C63.17. The antenna of EUT transmitter was replaced by a coaxial cable. The impedance matching of connection, cable loss and external RF attenuator are taken into account. The EUT was arranged to communicate via a fixed carrier frequency between its transmitter and a companion device. The transmission was configured in burst mode with pseudo-random data as typical as normal operation.

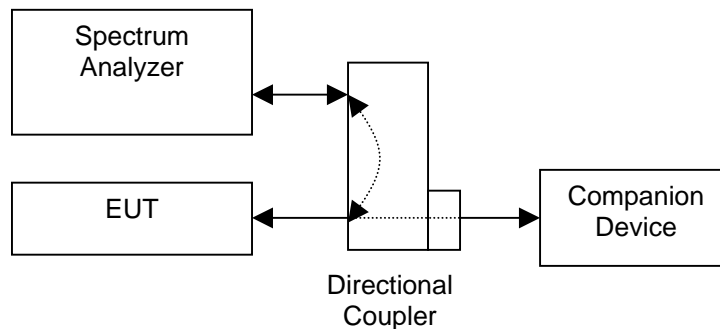

Figure 3.2.1

## 3.3 EUT Exercising Software

The EUT exercise program (if any) used during radiated and conducted testing was designed to exercise the various system components in a manner similar to a typical use.

## INTERTEK TESTING SERVICES

---

### 3.4 Details of EUT and Description of Peripherals

#### Details of EUT:

An AC adaptor and/or a battery (provided with the unit) were used to power the device. Their description are listed below.

- (1) Handset: A "Li-ion" type rechargeable battery (3.7V 650mAh)

#### Description of Peripherals:

- (1) Telephone Headset (Supplied by Intertek)
- (2) Base Unit, Model: RTX3080.103, FCC ID: ELIRTX3080 (Supplied by Client)
- (3) Handset Charger: A switching AC adaptor (100-240VAC to 5VDC 350mA, Model: SSW-1444US) (Supplied by Client)
- (4) Base Unit: A switching AC adaptor (100-240VAC to 12VDC 300mA, Model: SSW-1187US) (Supplied by Client)

## INTERTEK TESTING SERVICES

---

### 3.5 Measurement Uncertainty

When determining of the test conclusion, the Measurement Uncertainty test has been considered.

### 3.6 Equipment Modification

Any modifications installed previous to testing by RTX Consumer Products Hong Kong Ltd. will be incorporated in each production model sold/leased in the United States.

No modifications were installed by Commercial & Electrical Division, Intertek Testing Services Hong Kong Ltd.

All the items listed under section 3.0 of this report are confirmed by:

*Confirmed by:*

*Leung Wai Leung, Tommy  
Senior Manager  
Intertek Testing Services Hong Kong Ltd.  
Agent for RTX Consumer Products Hong Kong Ltd.*

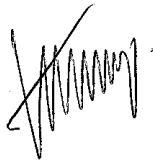

\_\_\_\_\_ Signature

June 4, 2008 \_\_\_\_\_ Date

**EXHIBIT 4  
MEASUREMENT RESULTS**



## INTERTEK TESTING SERVICES

---

Company: RTX Consumer Products Hong Kong Ltd.  
Model: CT8010 DECT Handset - INT

Date of Test: May 19-24, 2008

### 4.0 Measurement Results

#### 4.1 Emission Bandwidth, FCC Rule 15.323(a):

Operation shall be contained within the 1920 – 1930 MHz band. The emission bandwidth (*B*) shall be less than 2.5 MHz and greater than 50 kHz.

Measurements are made in accordance with ANSI C63.17 sub-clause 6.1.3. Test setup is shown in section 3.2 Figure 3.2.1.

Test Results:

#### I. Traffic Carrier

Channel	Channel Frequency (MHz)	Measuring Signal Level	Measured Emission Bandwidth (MHz)	Results
Lowest	1921.536	26 dB down	1.48	Pass
Highest	1928.448	26 dB down	1.49	Pass

Please refer to the attached plots for more details:

Plot 1A: Lowest Channel 26dB Emission Bandwidth (Traffic Carrier)

Plot 1D: Highest Channel 26dB Emission Bandwidth (Traffic Carrier)

The plots of emission bandwidth and test frequency are saved as filename: 26bw.pdf

## INTERTEK TESTING SERVICES

---

Company: RTX Consumer Products Hong Kong Ltd.  
Model: CT8010 DECT Handset - INT

Date of Test: May 19-24, 2008

### 4.2 Peak Transmit Power, FCC Rule 15.319(c):

The peak transmit power ( $P_{EUT}$ ) shall not exceed  $100\mu W$  multiplied by the square root of the emission bandwidth ( $B$ ) in Hz or  $5 \log_{10} B - 10$  dBm. The peak transmit power shall be reduced by the amount in dB that the maximum directional gain of the antenna exceeds 3 dBi.

Measurements are made in accordance with ANSI C63.17 sub-clause 6.1.2. Test setup is shown in section 3.2 Figure 3.2.1. The cable loss and/or external attenuation are included in OFFSET function of spectrum analyzer.

Calculation of Peak Transmit Power Limit ( $P_{max}$ ):

$$\begin{aligned} [ \times ] \quad P_{max} &= 5 \log_{10} B - 10 \text{ dBm} && \text{when } G_A \leq 3\text{dBi} \\ [ \quad ] \quad P_{max} &= 5 \log_{10} B - 10 \text{ dBm} - (G_A - 3\text{dBi}) && \text{when } G_A > 3\text{dBi} \end{aligned}$$

Where  $G_A$  = EUT Antenna Gain: 0 dBi

$B$  = Measured Emission Bandwidth: (26dB down BW) in Hz

Test Results:

#### I. Traffic Carrier

Channel	Channel Frequency (MHz)	Measured Peak Transmit Power (dBm)	Limit (dBm)	Results
Lowest	1921.536	20.60	20.85	Pass
Highest	1928.448	20.48	20.87	Pass

Please refer to the attached plots for more details:

Plot 2A: Lowest Channel Peak Transmit Power (Traffic Carrier)

Plot 2B: Highest Channel Peak Transmit Power (Traffic Carrier)

The plots of peak transmit power are saved as filename: peaktp.pdf

## INTERTEK TESTING SERVICES

---

Company: RTX Consumer Products Hong Kong Ltd.  
Model: CT8010 DECT Handset - INT

Date of Test: May 19-24, 2008

### 4.3 Power Spectral Density, FCC Rule 15.319(d):

Power spectral density shall not exceed 3 mW (4.8dBm) in any 3 kHz bandwidth as measured with a spectrum analyzer having a resolution bandwidth of 3 kHz.

Measurements are made in accordance with ANSI C63.17 sub-clause 6.1.5. Test setup is shown in section 3.2 Figure 3.2.1.

Test Results:

#### I. Traffic Carrier

Channel	Channel Frequency (MHz)	Measured Power Spectral Density (dBm/3kHz)	Limit (dBm/3 kHz)	Results
Lowest	1921.536	-6.5	4.8	Pass
Highest	1928.448	-12.4	4.8	Pass

Please refer to the attached plots for more details:

Plot 3A: Lowest Channel Power Spectral Density (Traffic Carrier)

Plot 3B: Highest Channel Power Spectral Density (Traffic Carrier)

The plots of the power spectral density are saved as filename: psd.pdf

## INTERTEK TESTING SERVICES

---

Company: RTX Consumer Products Hong Kong Ltd.  
Model: CT8010 DECT Handset - INT

Date of Test: May 19-24, 2008

### 4.4 Unwanted Emission Inside the Sub-Band, FCC Rule 15.323(d):

Emissions inside the sub-band must comply with the following emission mask:

1. In the bands between  $1B$  and  $2B$  measured from the center of the emission bandwidth, emission shall be at least 30 dB below the permitted peak transmit power; i.e. -9.5 dBm
2. In the bands between  $2B$  and  $3B$  measured from the center of the emission bandwidth, emission shall be at least 50 dB below the permitted peak transmit power; i.e. -29.5 dBm
3. In the bands between  $3B$  and the band edge, emission shall be at least 60 dB below the permitted peak transmit power. i.e. -39.5 dBm

Where  $B$  = emission bandwidth in Hz

Measurements are made in accordance with ANSI C63.17 sub-clause 6.1.6.1. Test setup is shown in section 3.2 Figure 3.2.1.

Test Results:

#### I. Traffic Carrier

Channel	Channel Frequency (MHz)	Results
Lowest	1921.536	Pass
Highest	1928.448	Pass

Please refer to the attached plots for more details:

Plot 4A: Lowest Channel Unwanted Emission Inside the Sub-Band (Traffic Carrier)

Plot 4B: Highest Channel Unwanted Emission Inside the Sub-Band (Traffic Carrier)

The plots of the unwanted emission inside the sub-band are saved as filename: inband.pdf

## INTERTEK TESTING SERVICES

---

Company: RTX Consumer Products Hong Kong Ltd.  
Model: CT8010 DECT Handset - INT

Date of Test: May 19-24, 2008

### 4.5 Emissions Outside the Sub-Band, FCC Rule 15.323(d):

Emissions outside the sub-band shall be attenuated below a reference power of 112 mW (20.5 dBm) as follows:

1. 30 dB between the band edge and 1.25 MHz above or below the band;
2. 50 dB between 1.25 and 2.5 MHz above or below the band; and
3. 60 dB at 2.5 MHz or greater above or below the band, or shall meet the requirement of FCC Rule 15.319(g) which shall not exceed the limits of FCC Rule 15.209.

Example: Calculation of Limit for emissions between the band edge and 1.25 MHz (1920.000 – 1918.750 MHz)

The emissions shall not exceed the Limit: 20.5 dBm – 30 dB = -9.5 dBm

Measurements are made in accordance with ANSI C63.17 sub-clause 6.1.6.2. As EUT has non-detachable antenna(s), radiated emissions test method is used for out-of-band emissions tests. Emissions that are directly caused by digital circuits in the transmit path and transmitter portion are measured. Test setup and procedures are described in section 3.2 Figure 3.2.1.

### Test Results:

Channel	Carrier Frequency (MHz)	Measured Band (MHz)	Limit (dBm)	Results
Lowest	1921.536	1920.000 - 1918.750	-9.5	Pass
		1918.750 - 1917.500	-29.5	Pass
		0.009 - 1917.500 & 1932.500 - 19300.000	-39.5	Pass
Highest	1928.448	1930.000 - 1931.250	-9.5	Pass
		1931.250 - 1932.500	-29.5	Pass
		0.009 - 1917.500 & 1932.500 - 19300.000	-39.5	Pass

Please refer to the section 4.5.1 to 4.5.4 for more details.

## INTERTEK TESTING SERVICES

---

Company: RTX Consumer Products Hong Kong Ltd.  
Model: CT8010 DECT Handset - INT  
Mode: Transmission

Date of Test: May 19-24, 2008

### 4.5.1 Radiated Emissions Configuration Photographs:

Worst Case Radiated Emission  
at

3843.072 MHz

The worst case radiated emission configuration photographs are saved as filename:  
cofing photos.pdf

## INTERTEK TESTING SERVICES

---

Company: RTX Consumer Products Hong Kong Ltd.  
Model: CT8010 DECT Handset - INT  
Mode: Transmission

Date of Test: May 19-24, 2008

### 4.5.2 Radiated Emissions Data:

Data are included of the worst case configuration (the configuration which resulted in the highest emission levels). A sample calculation, configuration photographs and data tables of the emissions are included. All measurements were performed with peak detection unless otherwise specified.

The data in tables 1-3 list the significant emission frequencies, the limit and the margin of compliance.

Judgement: Passed by 5.8 dB margin

### **TEST ENGINEER:**



---

*Signature*

Ken Sit, Supervisor  
*Typed/Printed Name*

June 4, 2008  
*Date*

## INTERTEK TESTING SERVICES

---

Company: RTX Consumer Products Hong Kong Ltd.  
Model: CT8010 DECT Handset - INT  
Mode: Transmission

Date of Test: May 19-24, 2008

Table 1

**Radiated Emissions Data  
Pursuant To FCC Part 15 Section 15.323 (d) Emissions Requirements**

Lowest Channel:

Polarization	Frequency (MHz)	Measured Power (dBm)	Power Limit (dBm)	Margin (dB)
H	1919.300	-42.6	-9.5	-33.1
H	1918.560	-51.8	-29.5	-22.3
H	1917.306	-53.9	-39.5	-14.4
V	3843.072	-45.3	-39.5	-5.8
H	5764.608	-46.7	-39.5	-7.2
H	7686.144	-49.9	-39.5	-10.4
H	9607.680	-52.0	-39.5	-12.5
H	11529.216	-52.4	-39.5	-12.9

NOTES:

1. Peak detector is used for the emission measurement.
2. All measurements were made at 3 meters.
3. Negative value in the margin column shows emission below limit.



## INTERTEK TESTING SERVICES

---

Company: RTX Consumer Products Hong Kong Ltd.  
Model: CT8010 DECT Handset - INT  
Mode: Transmission

Date of Test: May 19-24, 2008

Table 2

**Radiated Emissions Data  
Pursuant To FCC Part 15 Section 15.323 (d) Emissions Requirements**

Highest Channel:

Polarization	Frequency (MHz)	Measured Power (dBm)	Power Limit (dBm)	Margin (dB)
H	1930.577	-42.4	-9.5	-32.9
H	1931.707	-51.6	-29.5	-22.1
H	1932.963	-53.4	-39.5	-13.9
V	3856.896	-45.9	-39.5	-6.4
H	5785.344	-46.6	-39.5	-7.1
H	7713.792	-49.8	-39.5	-10.3
H	9642.240	-51.4	-39.5	-11.9
H	11570.688	-52.9	-39.5	-13.4

NOTES:

1. Peak detector is used for the emission measurement.
2. All measurements were made at 3 meters.
3. Negative value in the margin column shows emission below limit.

## INTERTEK TESTING SERVICES

---

Company: RTX Consumer Products Hong Kong Ltd.  
Model: CT8010 DECT Handset - INT  
Mode: Talk

Date of Test: May 19-24, 2008

Table 3

**Radiated Emissions Data  
Pursuant To FCC Part 15 Section 15.323 (d) Emissions Requirements**

Polarization	Frequency (MHz)	Measured Power (dBm)	Power Limit (dBm)	Margin (dB)
V	33.765	-67.9	-39.5	-28.4
V	47.228	-67.5	-39.5	-28.0
V	58.874	-66.4	-39.5	-26.9
V	64.545	-66.6	-39.5	-27.1
V	70.716	-67.0	-39.5	-27.5
V	136.257	-67.4	-39.5	-27.9

NOTES:

1. Peak detector is used for the emission measurement.
2. All measurements were made at 3 meters.
3. Negative value in the margin column shows emission below limit.

## INTERTEK TESTING SERVICES

---

Company: RTX Consumer Products Hong Kong Ltd.  
Model: CT8010 DECT Handset - INT

Date of Test: May 19-24, 2008

### 4.5.3 Field Strength Calculation

The field strength is calculated by adding the reading on the Spectrum Analyzer to the factors associated with preamplifiers (if any), antennas, cables, pulse desensitization and average factors (when specified limit is in average and measurements are made with peak detectors). A sample calculation is included below.

$$FS = RA + AF + CF - AG + PD + AV$$

Where

- FS = Field Strength in dB $\mu$ V/m
- RA = Receiver Amplitude (including preamplifier) in dB $\mu$ V
- CF = Cable Attenuation Factor in dB
- AF = Antenna Factor in dB
- AG = Amplifier Gain in dB
- PD = Pulse Desensitization in dB
- AV = Average Factor in -dB

In the radiated emission table which follows, the reading shown on the data table may reflect the preamplifier gain. An example of the calculations, where the reading does not reflect the preamplifier gain, follows:

$$FS = RA + AF + CF - AG + PD + AV$$

#### Example

Assume a receiver reading of 62.0 dB $\mu$ V is obtained. The antenna factor of 7.4 dB and cable factor of 1.6 dB is added. The amplifier gain of 29.0 dB is subtracted. The pulse desensitization factor of the spectrum analyzer is 0.0 dB, and the resultant average factor is -10.0 dB. The net field strength for comparison to the appropriate emission limit is 32.0 dB $\mu$ V/m. This value in dB $\mu$ V/m is converted to its corresponding level in  $\mu$ V/m.

RA = 62.0 dB $\mu$ V  
AF = 7.4 dB  
CF = 1.6 dB  
AG = 29.0 dB  
PD = 0.0 dB  
AV = -10 dB

$$FS = 62.0 + 7.4 + 1.6 - 29.0 + 0.0 + (-10.0) = 32.0 \text{ dB}\mu\text{V/m}$$

$$\text{Level in mV/m} = \text{Common Antilogarithm} [(32.0 \text{ dB}\mu\text{V/m})/20] = 39.8 \mu\text{V/m}$$

## INTERTEK TESTING SERVICES

---

Company: RTX Consumer Products Hong Kong Ltd.  
Model: CT8010 DECT Handset - INT

Date of Test: May 19-24, 2008

### 4.5.4 Average Factor Calculation and Transmitter ON Time Measurements, FCC Rule 15.35(b), (c)

- The EUT antenna output port was connected to the input of the spectrum analyzer. The analyzer center frequency was set to EUT RF channel carrier. The SPAN function on the analyzer was set to ZERO. The transmitter ON time was determined from the resultant time-amplitude display:

Please refer to the attached plots for more details:

Plot 5A: Transmitter ON Time Measurements (Traffic Carrier)

Plot 5B: Transmitter ON Time Measurements (Dummy Carrier)

The plots of Transmitter ON Time Measurements are saved as filename: txon.pdf

- Please refer to the attached transmitter timing diagram that are provided by manufacturer

- Not applicable - No average factor is required.

- Please refer to Exhibit 2.2 Technical Description for more details

## INTERTEK TESTING SERVICES

---

Company: RTX Consumer Products Hong Kong Ltd.  
Model: CT8010 DECT Handset - INT

Date of Test: May 19-24, 2008

### 4.6 AC Power Lines Conducted Emissions from Transmitter portion of EUT, FCC Rule 15.315:

The AC power lines conducted emission shall not exceed the limits of FCC Rule 15.207.

Measurements are made in accordance with ANSI C63.4 sub-clause 7. Emissions that are directly caused by digital circuits in the transmit path and transmitter portion are measured.

Not applicable – EUT is only powered by battery for operation.

EUT connects to AC power lines. Emission Data are listed in following pages. Please refer to the section 4.6.1 to 4.6.2 for more details.

## INTERTEK TESTING SERVICES

---

Company: RTX Consumer Products Hong Kong Ltd.  
Model: CT8010 DECT Handset - INT  
Mode: Speakerphone with Charger

Date of Test: May 19-24, 2008

### 4.6.1 AC Power Lines Conducted Emissions Configuration Photographs:

#### Worst Case AC Power Line Conducted Emission

The worst case radiated emission configuration photographs are saved as filename:  
config photos.pdf

## INTERTEK TESTING SERVICES

---

Company: RTX Consumer Products Hong Kong Ltd.  
Model: CT8010 DECT Handset - INT  
Mode: Speakerphone with Charger

Date of Test: May 19-24, 2008

### 4.6.2 AC Power Lines Conducted Emissions Data:

The data on the following pages list the significant emission frequencies, the limit, and the margin of compliance.

Judgement -

Passed by more than 20 dB margin

The worst case AC Power line conducted emission data are save as filename:  
conduct.pdf

### **TEST ENGINEER:**



---

*Signature*

Ken Sit, Supervisor  

---

*Typed/Printed Name*

June 4, 2008  

---

*Date*

## INTERTEK TESTING SERVICES

---

Company: RTX Consumer Products Hong Kong Ltd.  
Model: CT8010 DECT Handset - INT

Date of Test: May 19-24, 2008

### 4.7 Radio Frequency Radiation Exposure, FCC Rule 15.319(i):

EUT is subject to the radio frequency exposure requirements specified in FCC Rule § 1.1307(b), 2.1091 and 2.1093. It shall be considered to operate in a "general population / uncontrolled" environment.

- EUT was evaluated for Specific Absorption Rate (SAR) evaluation compliance according to OET Bulletin 65, Supplement C (Edition 01-01). It is in compliance with the SAR evaluation requirements. The caution statement specified in the user manual. A SAR test report was submitted at the same time and saved as SAR report 1 of 2.pdf and SAR report 2 of 2.pdf
- EUT was evaluated for Maximum Permissible Exposure (MPE) evaluation compliance according to OET Bulletin 65, Supplement C (Edition 01-01). The evaluation calculation results are saved as filename: RF exposure info.pdf.



**EXHIBIT 5  
EQUIPMENT PHOTOGRAPHS**

## INTERTEK TESTING SERVICES

---

### 5.0 Equipment Photographs

The photographs are saved as filename: external photos.pdf & internal photos.pdf

**INTERTEK TESTING SERVICES**

---

**EXHIBIT 6  
TECHNICAL SPECIFICATIONS**

## INTERTEK TESTING SERVICES

---

### 6.0 Technical Specifications

The circuit diagram are saved as filename: circuit.pdf.

**INTERTEK TESTING SERVICES**

---

**EXHIBIT 7  
LETTER OF AGENCY**

## INTERTEK TESTING SERVICES

---

### 7.0 Letter of Agency

A copy of the Letter of Agency is saved as filename: letter of agency.pdf

**INTERTEK TESTING SERVICES**

---

**EXHIBIT 8  
CONFIDENTIALITY REQUEST**

## INTERTEK TESTING SERVICES

---

### 8.0 Confidentiality Request

A copy of the Confidentiality Request is saved as filename: request.pdf